

STATE OF TEXAS DEPARTMENT OF TRANSPORTATION

PLANS OF PROPOSED STATE HIGHWAY IMPROVEMENT

PROJECT NO. STP 2025(155)HES

PROJECT LIMITS: SH 64, Etc. IN SMITH COUNTY, Etc.

FEDERAL AID PROJECT NO.			
STP 2025(155)HES			
CONT	SECT	JOB	HIGHWAY
0910	16	180	SH 64, Etc.
DIST	COUNTY		SHEET NO.
TYL	SMITH, Etc.		1

INDEX OF SHEETS	
SHEET NO.	DESCRIPTION
1	TITLE SHEET
2	SUPPLEMENTAL INDEX OF SHEETS

FINAL PLANS

LETTING DATE: _____
 DATE CONTRACTOR BEGAN WORK: _____
 DATE WORK WAS COMPLETED & ACCEPTED: _____
 FINAL CONTRACT COST: \$ _____
 CONTRACTOR: _____
 USED _____ OF _____ ALLOTTED DAYS: _____

FINAL AS BUILT PLANS

THE CONSTRUCTION WAS PERFORMED UNDER MY SUPERVISION
IN ACCORDANCE WITH THE PLANS AND CONTRACT

DATE:

 AREA ENGINEER

FOR THE CONSTRUCTION OF HIGHWAY SAFETY IMPROVEMENT PROGRAM (HSIP) PROJECTS
CONSISTING OF INSTALLATION OF ILLUMINATION AT INTERSECTIONS

**INTERSECTION ILLUMINATION
CSJ: 0910-16-180**

1. LOCATION 1 :
SH 64 AT FM 15
SH 64
SPEED LIMIT = 70 MPH
AADT(2022) = 8,779

2. LOCATION 2 :
SH 64 AT FM 848
SH 64
SPEED LIMIT = 55 MPH
AADT (2022) = 5,963

3. LOCATION 3 :
SH 64 AT FM 2089
SH 64
SPEED LIMIT = 70 MPH
AADT (2022) = 5,963

4. LOCATION 4:
US 259 AT FM 850
US 259
SPEED LIMIT = 70 MPH
AADT (2022) = 12,277

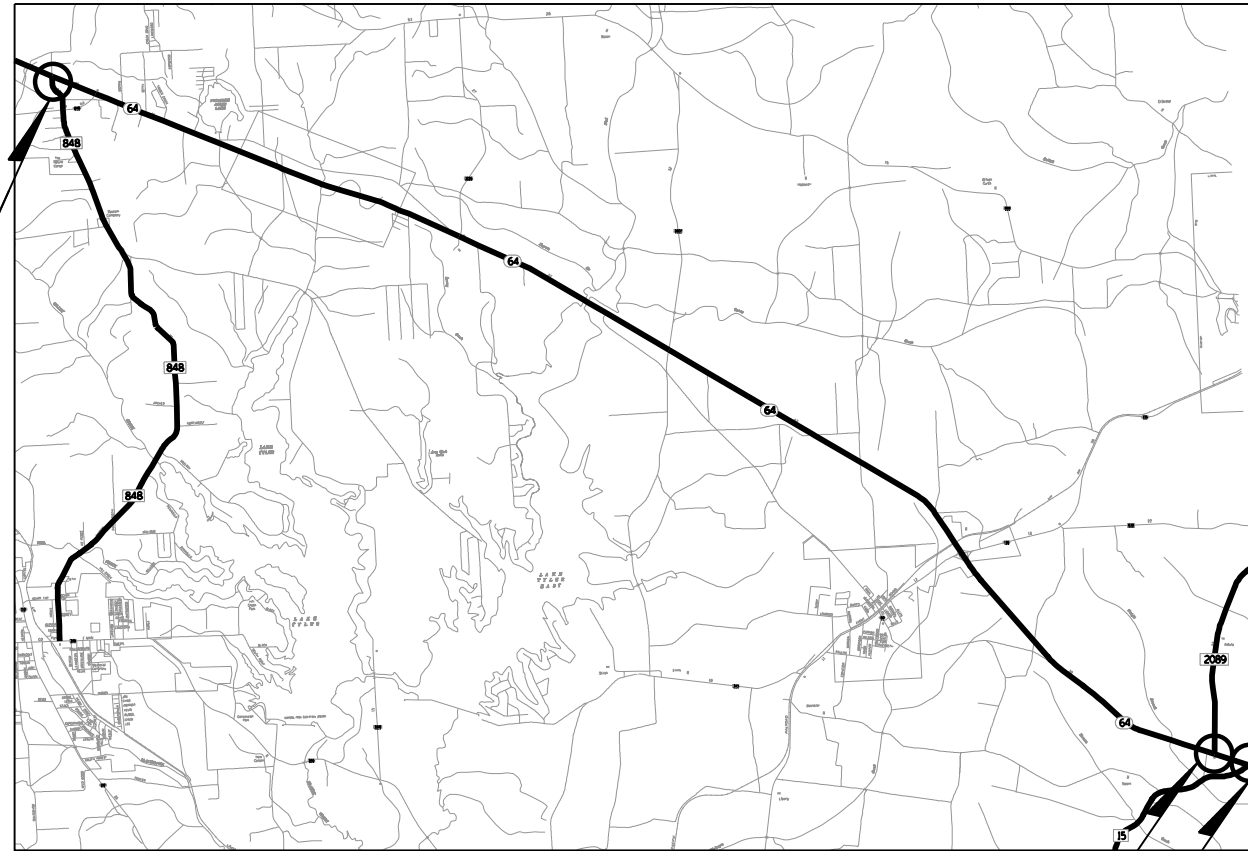

SMITH COUNTY

VICINITY MAP
NOT TO SCALE

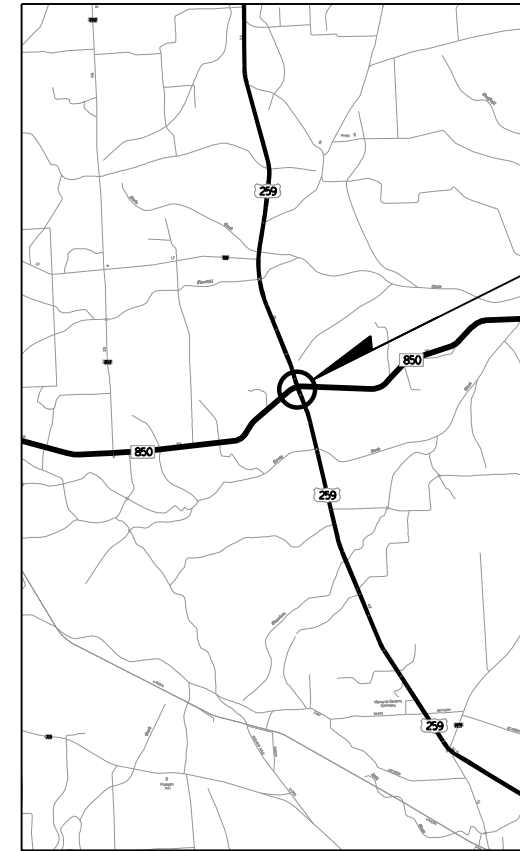

RUSK COUNTY

VICINITY MAP
NOT TO SCALE

LOCATION 2
SH 64 AT FM 848

LOCATION 3
SH 64 AT FM 2089

LOCATION 1
SH 64 AT FM 15

LOCATION 4
US 259 AT FM 850

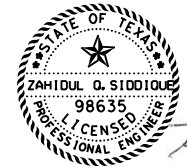

9/6/2024



REQUIRED SIGNS SHALL BE IN ACCORDANCE WITH BC (1) - 21 THRU BC (12) - 21
AND THE "TEXAS MANUAL ON UNIFORM TRAFFIC CONTROL DEVICES."

SPECIFICATIONS ADOPTED BY THE TEXAS DEPARTMENT OF TRANSPORTATION,
SEPTEMBER 1, 2024 AND SPECIFICATION ITEMS LISTED AND DATED AS FOLLOWS,
SHALL GOVERN ON THIS PROJECT: REQUIRED CONTRACT PROVISIONS FOR ALL
FEDERAL-AID CONSTRUCTION CONTRACTS (FORM FHWA 1273, OCTOBER 23, 2023)

EXCEPTIONS: NONE
EQUATIONS: NONE
RAILROAD CROSSINGS: NONE

© 2024 by Texas Department of Transportation all rights reserved

9/6/2024
SUBMITTED FOR LETTING: _____
 DocuSigned by:

 ROLANDO MENDEZ
 DISTRICT DESIGN ENGINEER

9/6/2024
APPROVED FOR LETTING: _____
 DocuSigned by:

 ZAHIDUL Q. SIDDIQUE
 DISTRICT ENGINEER

DATE: 9/6/2024 9:13:56 AM
FILE: c:\pw\infatech\zahidul.siddique\dms4311\TYL_WA3_TITLE.dgn

SUPPLEMENTAL INDEX OF SHEETS

GENERAL

<u>SHEET NO.</u>	<u>DESCRIPTION</u>
1	TITLE SHEET
2	SUPPLEMENTAL INDEX OF SHEETS
3, 3A -3D	GENERAL NOTES
4	ESTIMATE AND QUANTITY SHEET
5	SUMMARY OF QUANTITIES

ENVIRONMENTAL ISSUES

<u>SHEET NO.</u>	<u>DESCRIPTION</u>
36 - 37	SWP3
38	EPIC
38A	CONCRETE WASHOUT DETAIL

<u>SHEET NO.</u>	<u>STANDARDS</u>
* 39 - 41	EC (9) - 16

TRAFFIC CONTROL PLAN

<u>SHEET NO.</u>	<u>STANDARDS</u>
* 6 - 15	BC (1) - 21 THRU BC (10) - 21
* 16	TCP (1-1) - 18
* 17	TCP (1-2) - 18
* 18	WZ (RS) - 22

TRAFFIC ITEMS

<u>SHEET NO.</u>	<u>DESCRIPTION</u>
19	ILLUMINATION LAYOUT - SH 64 AT FM 15 - SMITH COUNTY
20	ILLUNINATION LAYOUT - SH 64 AT FM 848 - SMITH COUNTY
21	ILLUMINATION LAYOUT - SH 64 AT FM 2089 - SMITH COUNTY
22	ILLUMINAITON LAYOUT - US 259 AT FM 850 - RUSK COUNTY

<u>SHEET NO.</u>	<u>STANDARDS</u>
* 23	ED (1) - 14
* 24	ED (3) - 14
* 25	ED (4) - 14
* 26	ED (5) - 14
* 27	ED (6) - 14
* 28	ED (7) - 14
* 29	ED (11) - 14
* 30 - 31	RID (1) - 20 THRU RID (2) - 20
* 32 - 35	RIP (1) - 19 THRU RIP (4) - 19

* THE STANDARD SHEETS SPECIFICALLY IDENTIFIED ON THIS SHEET HAVE BEEN ISSUED BY ME AND ARE APPLICABLE TO THIS PROJECT.

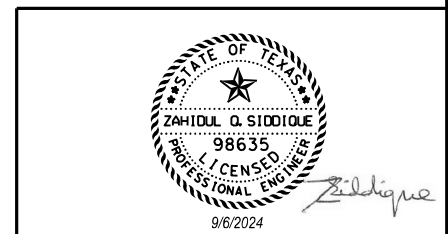

NO.	DATE	REVISION	APPROVED



SUPPLEMENTAL INDEX OF SHEETS

SHEET 1 OF 1

CONT	SECT	JOB	HIGHWAY
0910	16	180	SH 64, Etc.
DIST	COUNTY	SHEET NO.	
TYL	SMITH, Etc.	2	

County: Smith, Etc.

Control: 0910-16-180

Highway: SH 64, Etc.

GENERAL NOTES:

GENERAL.

Contractor questions on this project are to be addressed to the following individuals:

Juanita Daniels-West, P.E. Juanita.Danielswest@txdot.gov

Steven Swindell, P.E. Steven.Swindell@txdot.gov

For Q&A on Proposals navigate to:

<https://tableau.txdot.gov/views/ProjectInformationDashboard/NoticetoContractors>

Use the dashboard to navigate to the project you are interested in by scrolling or filtering the dashboard using the controls on the left. Hover over the blue hyperlink for the project and click on the link in the window that pops up to view the Q&A.

All relevant project documentation including Contract Time Determinations and cross-sections will still be posted to the districts FTP website.

<https://ftp.dot.state.tx.us/pub/txdot-info/Pre-Letting%20Responses/Tyler%20District/Construction%20Projects>

ITEM 5. CONTROL OF THE WORK

If utility lines need adjustments during construction operations, modify operations and continue the work in a manner that will allow others to make the utility adjustments. Additional working time may be allowed for delays caused by these utility adjustments.

Utility locations shown on the plans are approximate. Contact utilities in accordance with Article 5.6., "Cooperating With Utilities."

Prior to beginning driveway and intersection work, submit a detailed construction sequence to be approved by the Engineer. Driveway and intersection completion includes existing surface removal, structure removal, removal of debris from the project site, installing the new RCP and SETs, backfilling, grading ditches to drain, and installing the permanent driveway or intersection surface (or all-weather drive surface as allowed).

County: Smith, Etc.

Control: 0910-16-180

Highway: SH 64, Etc.

ITEM 6. CONTROL OF MATERIALS

The Buy America Material Classification Sheet for clarification on material categorization is located at the link below:

<https://www.txdot.gov/business/resources/materials/buy-america-material-classification-sheet.html>

ITEM 7. LEGAL RELATIONS AND RESPONSIBILITIES

Concrete truck drivers and concrete pump operators are required to wash out only in designated areas specifically constructed for eliminating run-off. Dispose of materials in accordance with federal, state, and local requirements.

Maintain positive drainage for permanent and temporary work for the duration of the project. The Contractor will be responsible for any items associated with the temporary or interim drainage and all related maintenance. This work will be subsidiary to various bid items.

The total disturbed area for this project is 0 acres. The disturbed area in this project and the Contractor Project Specific Locations (PSL's) within 1 mile of the project limits for the Contract will further establish the authorization requirements for storm water discharges. The Department will obtain an authorization to discharge storm water from the Texas Commission on Environmental Quality (TCEQ) for the construction activities shown on the plans. Obtain any required authorization from the TCEQ for any Contractor PSL for construction support activities on or off the ROW. When the total area disturbed for all projects in the Contract and PSLs within 1 mile of the project limits exceed 5 acres, before disturbance, provide a copy of the Contractor NOI for PSLs on the ROW and within 1 mile of the project limits to the Engineer and to any local government that operates a Municipal Separate Storm Sewer System (MSSS).

In accordance with Article 7.9, provide and maintain adequate, neat and sanitary toilet accommodations within the project limits for employees, including State employees.

No significant traffic generator events identified.

ITEM 8. PROSECUTION AND PROGRESS

Working days will be computed and charged in accordance with Section 8.3.1.1., "Five-Day Workweek."

Special Provision 008-005 (90-day convenience delay) is included in this Contract. This is to allow for the manufacturer's delay in providing the traffic signal poles.

ITEM 9. MEASUREMENT & PAYMENT

In accordance with Article 9.1., "Measurement of Quantities," furnish the tare and maximum gross weights as well as the volume capacity of all vehicles, trucks, truck-tractors, trailers, semi-trailers, or combination of such vehicles used to deliver materials for this Contract. Also, furnish calculations supporting these weights and capacities. Provide all measurements required for pay a minimum of 2 days before the trucks are used.

ITEM 100. PREPARING RIGHT OF WAY

Perform work as necessary off the right of way on temporary or drainage easements and at those locations where improvements have been taken or partially taken by right of way acquisition. Review these locations with the Area Engineer. The cost of this work will be included in the unit price bid for this Item.

Burning will not be permitted within the right of way.

Do not use a forestry type mulcher for grinding. Tub grinders will be allowed.

A boom axe will not be allowed to trim trees.

Remove or stockpile remaining trees and brush at the end of the day. Barricade the stockpile in accordance with Item 502. Remove stockpiles weekly.

ITEM 416. DRILLED SHAFT FOUNDATIONS

Hand dressing of soil around the concrete foundations for luminaries will be required as directed. Place the level of soil at a 6:1 slope or flatter, where possible, and extend it from the top of the concrete foundation to the established grades. This work will not be paid for directly, but will be subsidiary to this Item.

Provide a low clearance drilling rig to avoid overhead transmission line.

ITEMS 420. CONCRETE SUBSTRUCTURES

Do not use membrane curing for structural elements.

ITEM 421. HYDRAULIC CEMENT CONCRETE

The Engineer will provide strength-testing equipment.

Provide the Engineer with a mixture design report using Department-provided software in accordance with Section 421.4.1., "Classification of Concrete Mix Designs," of the standard

specifications. Include in the report the producer's plant, all materials sources, and a unique identification number for the design.

Air is not required on concrete cast-in-place elements on this project. If the Contractor proposes the use of an existing concrete design containing air, the Engineer must approve the design in writing before placement. If used, air testing will be performed in accordance with the specifications.

ITEM 432. RIPRAP

Locations and quantities may be varied as directed by the Engineer to accommodate field conditions.

ITEM 502. BARRICADES, SIGNS, AND TRAFFIC HANDLING

The traffic control plan for this Contract consists of: the installation and maintenance of warning signs and other traffic control devices shown on the plans; specification data, which may be included in the general notes; applicable provisions of the Texas Manual on Uniform Traffic Control Devices (TMUTCD); traffic control plan sheets included on the plans; standard BC sheets; Compliant Work Zone Traffic Control Device List, and Item 502 of the standard specifications.

Use ground-mounted sign mounts with two posts for all temporary work zone signs unless otherwise directed.

Inspect and correct deficiencies each day throughout the duration of the Contract. In accordance with Article 502.4., "Payment," no payment will be made for the month if the Contractor fails to provide or properly maintain signs and devices in compliance with Contract requirements. Temporary warning signs that are visible when conditions do not apply will be considered improper maintenance of signs.

Provide at least one employee on call nights and weekends (or any other time that work is not in progress) for maintenance of signs and traffic control devices. This employee must have an address and telephone number near the project, as approved. Notify the Engineer in writing of the name, address, and telephone number of this employee. The Engineer will furnish this information to local law enforcement officials.

In addition to providing a Contractor's Responsible Person and a phone number for emergency contact, have an employee available to respond on the project for emergencies and for taking corrective measures within 30 minutes.

Sign all roads intersecting the project in accordance with current BC standards.

County: Smith, Etc.

Control: 0910-16-180

Highway: SH 64, Etc.

Refer to the traffic control plan sheets for traffic handling through the work area. Contractor may vary the signing arrangement and spacing as necessary to fit field conditions; however, any proposed changes in the traffic control plan must be approved before implementation.

When the sequence of work is shown on the plans, the Contractor may submit an alternate proposal for approval. Submit in writing all proposed variations and revisions.

High-visibility safety apparel is required for workers in accordance with the General Notes on current BC standards.

Place and maintain signs, channelizing devices, and flaggers to direct and route traffic at any location and for any period of time as may be required or directed.

When operations require a lane closure, provide cones, vertical panels, drums, signs, flaggers, and flashing arrow panels as necessary to route traffic around the closed lane as shown on the plans and as directed. Lane closures will be limited to one specific lane as directed.

Lane closures will not be allowed before 8:30 A.M. unless otherwise directed.

Unless otherwise approved, construction operations will not be allowed on Good Friday, Easter weekend, the Friday before Memorial Day thru Memorial Day, July 4th, the Friday before Labor Day thru Labor Day, the Wednesday before Thanksgiving Day thru Sunday, Christmas Eve, Christmas Day, New Year's Eve, New Year's Day, or on any other high traffic days or holidays as determined by the Engineer.

Erect R4-1 (Do Not Pass) and R4-2 (Pass With Care) signs to mark existing no-passing zones as directed. (These signs will not be required if these zones will not be eliminated during construction.)

Maintain existing roadside signs within this project's limits during this Contract. In order to accommodate the grading or other operations, temporarily relocate these signs in accordance with the TMUTCD as directed. Use ground-mounted sign mounts with two posts for all relocated signs unless otherwise directed. This work will not be paid for directly, but will be subsidiary to Item 502.

Provide truck-mounted attenuators (TMA) as shown on the appropriate traffic control plan sheets. Provide a letter certifying that all TMA used on this project meet NCHRP 350 or AASHTO Manual for Assessing Safety Hardware (MASH) requirements.

Regulate all construction activities and equipment to minimize inconvenience to the traveling public. At points where it is necessary for trucks to stop, load, or unload, provide warning signs and flaggers to protect the traveling public.

County: Smith, Etc.

Control: 0910-16-180

Highway: SH 64, Etc.

The pavement must be entirely open to traffic each night. Remove or clearly barricade all material stockpiles, equipment left overnight, or any obstruction within 30 ft. of a travelway as approved.

The Contractor Force Account "Safety Contingency" is intended to be used for work zone enhancements that could not be foreseen in the project planning and design stage for the purpose of improving the effectiveness of the Traffic Control Plan. These enhancements will be mutually agreed upon by the Engineer and the Contractor's Responsible Person based on weekly or more frequent traffic management reviews on the project. The Engineer may choose to use existing bid items if it does not slow the implementation of enhancement.

Provide flaggers at county roads, commercial driveways, and other intersecting roadways deemed necessary by the Engineer to maintain control of the work zone during one-lane two-way operations. Provide communication radios to each flagger in the work zone and the pilot vehicle operator.

Provide a pilot vehicle.

Prior to beginning work, the Contractor and Engineer must agree on the allowable length of lane closure.

All work required by these general notes, except as provided for by Item 502, will not be paid for directly, but will be subsidiary to Item 502 unless otherwise shown on the plans.

ITEM 505. TRUCK-MOUNTED ATTENUATOR (TMA) AND TRAILER ATTENUATOR (TA)

Shadow vehicles with truck mounted attenuator (TMA) are required on the traffic control plan and TCP standards for this project. The Contractor will be responsible for determining if one or more of these traffic control operations will be ongoing at the same time to determine the total number of TMAs needed for the project. Additional truck mounted attenuators (TMAs) may be required as deemed necessary by the Engineer.

The TMA/TA used for installation/removal of traffic control for a work area will be subsidiary to the TMA/TA used to perform the work.

ITEM 506. TEMPORARY EROSION, SEDIMENTATION, AND ENVIRONMENTAL CONTROLS

Remove dirt, silt, rocks, debris, and other foreign matter that accumulates in all structures due to project erosion and Contractor's operations. Keep stream channels open at all times. This work will not be paid for directly, but will be subsidiary to this Item.

County: Smith, Etc.

Control: 0910-16-180

Highway: SH 64, Etc.

The Storm Water Pollution Prevention Plan (SWP3) consists of temporary erosion control measures needed and provided for under this Item. The disturbed area is less than one acre and use of erosion control measures is not anticipated. If physical conditions encountered at the job site require necessary controls, BMP installation, maintenance, and removal will be paid as extra work on a force account basis per Articles 4.4 and 9.7

Provide the following Items for the SWP3 for this Contract as directed on a force account basis:

Temporary sediment control fence, seeding for erosion control, earthwork for erosion control, and vegetative watering.

ITEM 610. ROADWAY ILLUMINATION ASSEMBLIES

For both transformer and shoe-base type illumination poles, provide double-pole breakaway fuse holder as shown on the Texas Department of Transportation (TxDOT) Material Producer List. Category is "Roadway Illumination and Electrical Supplies." Fuse holder is shown on list under Items 610 & 620. Provide 10 amp time delay fuses.

The Roadway Illumination Pole (RIP-19) standard details were developed for installations in locations where the 3-second gust basic maximum wind speed is 110 mph, and where the elevation of the base of the pole is less than (i.e. not more than) 25 ft. above the elevation of surrounding terrain, in accordance with the current edition of the "AASHTO Standard Specifications for Structural Supports for Highway Signs, Luminaires and Traffic Signals." For poles to be installed in regions where the maximum basic wind speed exceeds 110 mph or to be mounted more than 25 ft. above the surrounding terrain, the Contractor must provide poles meeting the following requirements:

- A. **Submittals.** Following the electronic shop drawing submittal process (see ftp://ftp.dot.state.tx.us/pub/txdot-info/library/pubs/bus/bridge/e_submit_guide.pdf), the Contractor must submit to the Engineer, for approval, fabrication drawings and calculations for the poles. The drawings and calculations must be sealed by a Texas registered or licensed professional engineer (P.E.).
- B. **Luminaire Structural Support Requirements.** Lighting poles, arms, and anchor bolt assemblies must have a 25 year design life to safely resist dead loads, ice loads and the required basic wind speeds at the location of installation in accordance with the current edition of the AASHTO Design Specifications. For transformer base poles, the fabricator must include transformer base and connecting hardware in calculations and shop drawing submittals. All transformer bases should have been structurally tested to resist the theoretical plastic moment capacity of the pole. Certification of the plastic moment load test and FHWA breakaway requirement test of the model of base being furnished should be submitted with the shop drawings. Shop drawings must show breakaway base model

County: Smith, Etc.

Control: 0910-16-180

Highway: SH 64, Etc.

number, and manufacturer's name and logo. Manufacturer's shop drawings must include the ASTM designations for all materials to be used.

Fabricate steel roadway illumination poles in accordance with TxDOT standards RIP-2019 (Roadway Illumination Poles -2019). Poles fabricated according to RIP-2019 require no shop drawings.

Alternate designs to RIP-2019 or the use of aluminum to fabricate poles will require the submission of shop drawings electronically.

For instructions on submitting shop drawings electronically go to ftp://ftp.dot.state.tx.us/pub/txdot-info/library/pubs/bus/bridge/e_submit_guide.pdf

ITEM 618. CONDUIT

Furnish couplings and connections that are made wrench tight. All conduit must be brought into a ground or junction box and elbowed unless otherwise shown on the plans.

Place conduit in an area not exceeding 2 ft. in any direction from a straight line between terminal points. The minimum depth of the conduit should be 2 ft. except when crossing a roadway where the depth should not be more than 3 ft. nor less than 1 ft. below the bottom of the base material when placed by the jacking or boring method.

Where conduit is to be placed under existing riprap, cut the existing riprap to neat lines as directed and replace to match original condition after conduit placement.

The Contractor may, at his option, substitute high-density polyethylene (HDPE) conduit meeting the specifications of Item 622 for all bores requiring PVC schedule 40 conduit and, when approved by the Engineer, may substitute HDPE for schedule 80 bored conduit. HDPE must be the same size as the PVC conduit shown on the plans. HDPE must be terminated with UL listed fittings. HDPE may be threaded and used with threaded PVC connectors or couplings. HDPE should be extended through the bore in one continuous piece and should be coupled to RMC elbows or to PVC conduit at the bore pits prior to entering ground boxes (if ground boxes are required by the plans). HDPE should not contain conductors during installation in this manner. No additional compensation will be paid to the Contractor when HDPE is substituted for this purpose.

Do not use cast iron junction boxes in concrete traffic barriers and single slope traffic barriers. Use polymer concrete junction boxes instead of the cast iron junction boxes shown on standard sheets CSB(3), CSB(4), and SSCB(4). Mount the junction boxes flush (+ 0 in., - 1/2 in.) with concrete surface of concrete barrier.

Project Number:

Sheet 3D

County: Smith, Etc.

Control: 0910-16-180

Highway: SH 64, Etc.

The polymer concrete barrier box will not be paid for separately, but will be subsidiary to Item 618, "Conduit."

Use materials from prequalified material producers list as shown on the Material Producer List found on the TxDOT web site. Category is "Roadway Illumination and Electrical Supplies."

ITEMS 618, 624, 680 & 684. CONDT, GRND BX, INSTL HWY TRF SIG & TRF SIG CBL

The location of the controller, conductors, conduits, junction boxes and ground boxes are diagrammatic only and may be shifted by the Engineer to accommodate field conditions.

ITEM 620. ELECTRICAL CONDUCTORS

For both transformer and shoe-base type illumination poles, provide double-pole breakaway fuse holder as shown on the Material Producer List found on the TxDOT web site. Category is "Roadway Illumination and Electrical Supplies."

Fuse holder is shown on list under Items 610 & 620.

Provide 10 amp time delay fuses.

ITEM 624. GROUND BOXES

All ground boxes will be precast polymer concrete of the size and type specified on the plans.



Estimate & Quantity Sheet

CONTROLLING PROJECT ID 0910-16-180

DISTRICT Tyler
HIGHWAY Various

COUNTY Smith

CONTROL SECTION JOB				0910-16-180		TOTAL EST.	TOTAL FINAL
PROJECT ID				A00193096			
COUNTY				Smith			
HIGHWAY				Various			
ALT	BID CODE	DESCRIPTION	UNIT	EST.	FINAL		
	416-7040	DRILL SHAFT (RDWY ILL POLE) (30 IN)	LF	140.000		140.000	
	432-7005	RIPRAP (CONC)(CL B)	CY	4.900		4.900	
	500-7001	MOBILIZATION	LS	1.000		1.000	
	502-7001	BARRICADES, SIGNS AND TRAFFIC HANDLING	MO	2.000		2.000	
	505-7001	TMA (STATIONARY)	DAY	30.000		30.000	
	610-7196	IN RD IL (TY SA) 50T-8 (400W EQ) LED	EA	12.000		12.000	
	610-7200	IN RD IL (TY SA) 50T-12 (400W EQ) LED	EA	2.000		2.000	
	618-7030	CONDT (PVC) (SCH 40) (2")	LF	2,155.000		2,155.000	
	618-7055	CONDT (PVC) (SCH 80) (2") (BORE)	LF	790.000		790.000	
	620-7007	ELEC CONDR (NO.8) BARE	LF	3,215.000		3,215.000	
	620-7008	ELEC CONDR (NO.8) INSULATED	LF	6,430.000		6,430.000	
	624-7002	GROUND BOX TY A (122311)W/APRON	EA	11.000		11.000	
	628-7009	ELC SRV TY A 120/240 060(NS)SS(E)SP(O)	EA	4.000		4.000	
	18	EROSION CONTROL MAINTENANCE: CONTRACTOR FORCE ACCOUNT WORK (PART)	LS	1.000		1.000	
		SAFFTY CONTINGFNCY: CONTRACTOR FORCF ACCOUNT WORK (PART)	LS	1.000		1.000	

TRUCK MOUNTED ATTENUATOR SUMMARY				
CSJ	LAYOUT SHEET NUMBER	LOCATION	NUMBER OF TRUCKS	ITEM 505
				TMA (STATIONARY)
			EA	DAY
0910-16-180	19	SH 64 AT FM 15	1	5
	20	SH 64 AT FM 848	1	5
	21	SH 64 AT FM 2089	1	5
	22	US 259 AT FM 850	1	15
	PROJECT TOTAL			4

BASIS OF ESTIMATE			
ITEM	DESCRIPTION	QUANTITY	UNIT
500	MOBILIZATION	1	LS
502	BARRICADES, SIGNS AND TRAFFIC HANDLING	2.0	MO

NOTE: ESTIMATED NUMBER OF TRUCKS IS FOR WORKING AT ONE LOCATION AT A TIME. ADDITIONAL TRUCKS WILL BE REQUIRED IF WORKING AT MULTIPLE LOCATIONS AT THE SAME TIME.

ILLUMINATION SUMMARY														
CSJ	LAYOUT SHEET NUMBER	LOCATION	ITEM 416	ITEM 432	ITEM 610	ITEM 610	ITEM 618				ITEM 620		ITEM 624	ITEM 628
			DRILL SHAFT (RDWY ILL POLE) (30 IN)	RIPRAP (CONC) (CL B) (4")	IN RD ILL TY (SA) 50T-8 (400 EQ) LED	IN RD ILL TY (SA) 50T-12 (400 EQ) LED	CONDT PVC (SCH 40) (2")	CONDT PVC (SCH 80) (2") (BORE)	CONDUIT (PREPARE) *	GROUND BOX (PREPARE) *	ELEC COND (NO. 8) BARE	ELEC COND (NO. 8) INSULATED	GROUND BOX TY A (122311) W/APRON	ELC SRV TYP A 120/240 060 (NS) SS (E) SP (O)
			LF	CY	EA	EA	LF	LF	LF	EA	LF	LF	EA	EA
0910-16-180	19	SH 64 AT FM 15	20	0.7	2		140	175			315	630	3	1
			20	0.7	2		140	175			315	630	3	1
	20	SH 64 AT FM 848	20	0.7		2	70	285			355	710	3	1
			20	0.7		2	70	285			355	710	3	1
	21	SH 64 AT FM 2089	20	0.7	2		260	90			350	700	3	1
			20	0.7	2		260	90			350	700	3	1
22	US 259 AT FM 850	80	2.8	8		1685	240	290	4	2195	4390	2	1	
		80	2.8	8		1685	240	290	4	2195	4390	2	1	
PROJECT TOTAL			140	4.9	12	2	2155	790	290	4	3215	6430	11	4

* ITEMS ARE SUBSIDIARY TO ITEM 618. FOR CONTRACTORS INFORMATION ONLY.

NO.	DATE	REVISION	APPROVED



© 2024



Engineers & Innovators, LLC
TBPE REGISTRATION NO. F-18368

SUMMARY OF QUANTITIES

SHEET 1 OF 1

CONT	SECT	JOB	HIGHWAY
0910	16	180	SH 64, Etc.
DIST	COUNTY	SHEET NO.	
TYL	SMITH, Etc.	5	

DISCLAIMER: The use of this standard is governed by the "Texas Engineering Practice Act". No warranty of any kind is made by TxDOT for any purpose whatsoever. TxDOT assumes no responsibility for the conversion of this standard to other formats or for incorrect results or damages resulting from its use.

DATE: 5/16/2024 9:30:37 AM
 FILE: c:\pw-InfraTech\In.Zhang\dms47076\bc-21.dgn

BARRICADE AND CONSTRUCTION (BC) STANDARD SHEETS GENERAL NOTES:

1. The Barricade and Construction Standard Sheets (BC sheets) are intended to show typical examples for placement of temporary traffic control devices, construction pavement markings, and typical work zone signs. The information contained in these sheets meet or exceed the requirements shown in the "Texas Manual on Uniform Traffic Control Devices" (TMUTCD).
2. The development and design of the Traffic Control Plan (TCP) is the responsibility of the Engineer.
3. The Contractor may propose changes to the TCP that are signed and sealed by a licensed professional engineer for approval. The Engineer may develop, sign and seal Contractor proposed changes.
4. The Contractor is responsible for installing and maintaining the traffic control devices as shown in the plans. The Contractor may not move or change the approximate location of any device without the approval of the Engineer.
5. Geometric design of lane shifts and detours should, when possible, meet the applicable design criteria contained in manuals such as the American Association of State Highway and Transportation Officials (AASHTO), "A Policy on Geometric Design of Highways and Streets," the TxDOT "Roadway Design Manual" or engineering judgment.
6. When projects abut, the Engineer(s) may omit the END ROAD WORK, TRAFFIC FINES DOUBLE, and other advance warning signs if the signing would be redundant and the work areas appear continuous to the motorists. If the adjacent project is completed first, the Contractor shall erect the necessary warning signs as shown on these sheets, the TCP sheets or as directed by the Engineer. The BEGIN ROAD WORK NEXT X MILES sign shall be revised to show appropriate work zone distance.
7. The Engineer may require duplicate warning signs on the median side of divided highways where median width will permit and traffic volumes justify the signing.
8. All signs shall be constructed in accordance with the details found in the "Standard Highway Sign Designs for Texas," latest edition. Sign details not shown in this manual shall be shown in the plans or the Engineer shall provide a detail to the Contractor before the sign is manufactured.
9. The temporary traffic control devices shown in the illustrations of the BC sheets are examples. As necessary, the Engineer will determine the most appropriate traffic control devices to be used.
10. Where highway construction or maintenance work is being undertaken, other than mobile operations as defined by the Texas Manual on Uniform Traffic Control Devices, CSJ limit signs are required. CSJ limit signs are shown on BC(2). The OBEY WARNING SIGNS STATE LAW sign, STAY ALERT TALK OR TEXT LATER and the WORK ZONE TRAFFIC FINES DOUBLE sign with plaque shall be erected in advance of the CSJ limits. The BEGIN ROAD WORK NEXT X MILES, CONTRACTOR and END ROAD WORK signs shall be erected at or near the CSJ limits. For mobile operations, CSJ limit signs are not required.
11. Traffic control devices should be in place only while work is actually in progress or a definite need exists.
12. The Engineer has the final decision on the location of all traffic control devices.
13. Inactive equipment and work vehicles, including workers' private vehicles must be parked away from travel lanes. They should be as close to the right-of-way line as possible, or located behind a barrier or guardrail, or as approved by the Engineer.

WORKER SAFETY NOTES:

1. Workers on foot who are exposed to traffic or to construction equipment within the right-of-way shall wear high-visibility safety apparel meeting the requirements of ISEA "American National Standard for High-Visibility Apparel," or equivalent revisions, and labeled as ANSI 107-2004 standard performance for Class 2 or 3 risk exposure. Class 3 garments should be considered for high traffic volume work areas or night time work.
2. Except in emergency situations, flagger stations shall be illuminated when flagging is used at night.

COMPLIANT WORKZONE TRAFFIC CONTROL DEVICES

1. Only pre-qualified products shall be used. The "Compliant Work Zone Traffic Control Devices List" (CWZTCD) describes pre-qualified products and their sources.
2. Work zone traffic control devices shall be compliant with the Manual for Assessing safety Hardware (MASH).

<p>THE DOCUMENTS BELOW CAN BE FOUND ON-LINE AT http://www.txdot.gov</p>
COMPLIANT WORK ZONE TRAFFIC CONTROL DEVICES LIST (CWZTCD)
DEPARTMENTAL MATERIAL SPECIFICATIONS (DMS)
MATERIAL PRODUCER LIST (MPL)
ROADWAY DESIGN MANUAL - SEE "MANUALS (ONLINE MANUALS)"
STANDARD HIGHWAY SIGN DESIGNS FOR TEXAS (SHSD)
TEXAS MANUAL ON UNIFORM TRAFFIC CONTROL DEVICES (TMUTCD)
TRAFFIC ENGINEERING STANDARD SHEETS

SHEET 1 OF 12



**BARRICADE AND CONSTRUCTION
GENERAL NOTES
AND REQUIREMENTS**

BC(1)-21

FILE:	bc-21.dgn	DN:	TxDOT	CK:	TxDOT	DW:	TxDOT	CK:	TxDOT
© TxDOT	November 2002	CONT	SECT	JOB	HIGHWAY				
REVISIONS		0910	16	180	SH 64, Etc.				
4-03	7-13								
9-07	8-14								
5-10	5-21	TYL	SMITH, Etc.		SHEET NO.		6		

DATE: 5/16/2024 9:30:38 AM
 FILE: c:\pw-InfraTech\Lin_Zhang\dms47076\bc-21.dgn

DISCLAIMER: The use of this standard is governed by the "Texas Engineering Practice Act". No warranty of any kind is made by TxDOT for any purpose whatsoever. TxDOT assumes no responsibility for the conversion of this standard to other formats or for incorrect results or damages resulting from its use.

TYPICAL LOCATION OF CROSSROAD SIGNS

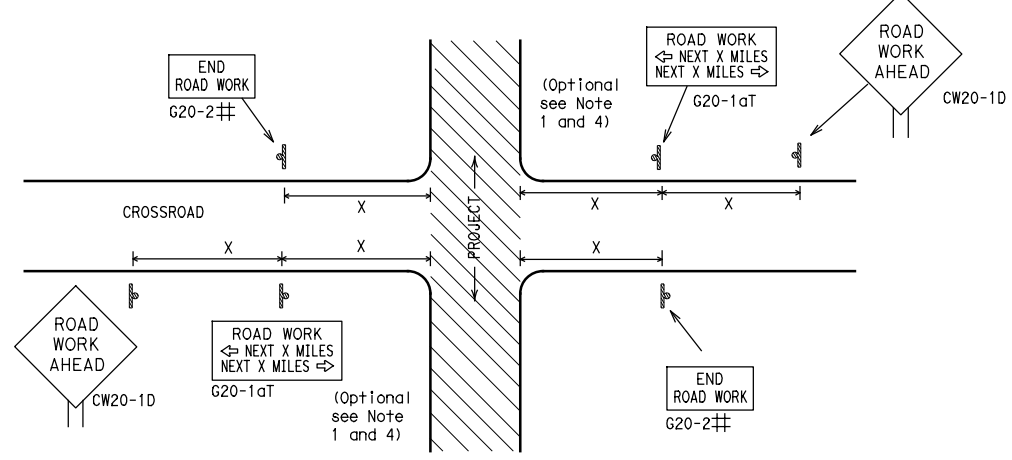

- ## May be mounted on back of "ROAD WORK AHEAD" (CW20-1D) sign with approval of Engineer. (See note 2 below)
- The typical minimum signing on a crossroad approach should be a "ROAD WORK AHEAD" (CW20-1D) sign and a (G20-2) "END ROAD WORK" sign, unless noted otherwise in plans.
 - The Engineer may use the reduced size 36" x 36" ROAD WORK AHEAD (CW20-1D) sign mounted back to back with the reduced size 36" x 18" "END ROAD WORK" (G20-2) sign on low volume crossroads (see Note 4 under "Typical Construction Warning Sign Size and Spacing"). See the "Standard Highway Sign Designs for Texas" manual for sign details. The Engineer may omit the advance warning signs on low volume crossroads. The Engineer will determine whether a road is low volume as per TMUTCD Part 5. This information shall be shown in the plans.
 - Based on existing field conditions, the Engineer/Inspector may require additional signs such as FLAGGER AHEAD, LOOSE GRAVEL, or other appropriate signs. When additional signs are required, these signs will be considered part of the minimum requirements. The Engineer/Inspector will determine the proper location and spacing of any sign not shown on the BC sheets, Traffic Control Plan sheets or the Work Zone Standard Sheets.
 - The "ROAD WORK NEXT X MILES" (G20-1aT) sign shall be required at high volume crossroads to advise motorists of the length of construction in either direction from the intersection. The Engineer will determine whether a roadway is considered high volume.
 - Additional traffic control devices may be shown elsewhere in the plans for higher volume crossroads.
 - When work occurs in the intersection area, appropriate traffic control devices, as shown elsewhere in the plans or as determined by the Engineer/Inspector, shall be in place.

T-INTERSECTION

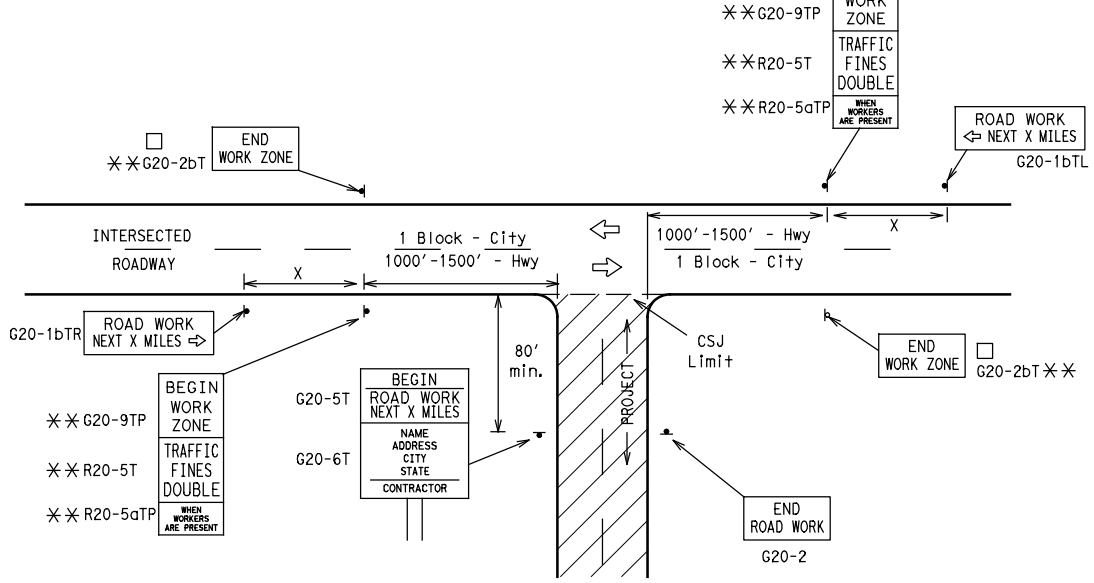

CSJ LIMITS AT T-INTERSECTION

- The Engineer will determine the types and location of any additional traffic control devices, such as a flagger and accompanying signs, or other signs, that should be used when work is being performed at or near an intersection.
- If construction closes the road at a T-intersection, the Contractor shall place the "CONTRACTOR NAME" (G20-6T) sign behind the Type 3 Barricades for the road closure (see BC(10) also). The "ROAD WORK NEXT X MILES" left arrow (G20-1bTL) and "ROAD WORK NEXT X MILES" right arrow (G20-1bTR) signs shall be replaced by the detour signing called for in the plans.

TYPICAL CONSTRUCTION WARNING SIGN SIZE AND SPACING^{1,5,6}

Sign Number or Series	SIZE		SPACING	
	Conventional Road	Expressway/Freeway	Posted Speed MPH	Sign Spacing "X" (Feet (Apprx.))
CW20 ⁴	48" x 48"	48" x 48"	30	120
CW21			35	160
CW22			40	240
CW23			45	320
CW25	36" x 36"	48" x 48"	50	400
CW1, CW2, CW7, CW8, CW9, CW11, CW14			55	500 ²
CW3, CW4, CW5, CW6, CW8-3, CW10, CW12			60	600 ²
			65	700 ²
	48" x 48"	48" x 48"	70	800 ²
			75	900 ²
			80	1000 ²
			*	*

* For typical sign spacings on divided highways, expressways and freeways, see Part 6 of the "Texas Manual on Uniform Traffic Control Devices" (TMUTCD) typical application diagrams or TCP Standard Sheets.

△ Minimum distance from work area to first Advance Warning sign nearest the work area and/or distance between each additional sign.

GENERAL NOTES

- Special or larger size signs may be used as necessary.
- Distance between signs should be increased as required to have 1500 feet advance warning.
- Distance between signs should be increased as required to have 1/2 mile or more advance warning.
- 36" x 36" "ROAD WORK AHEAD" (CW20-1D) signs may be used on low volume crossroads at the discretion of the Engineer as per TMUTCD Part 5. See Note 2 under "Typical Location of Crossroad Signs".
- Only diamond shaped warning sign sizes are indicated.
- See sign size listing in "TMUTCD", Sign Appendix or the "Standard Highway Sign Designs for Texas" manual for complete list of available sign design sizes.

WORK AREAS IN MULTIPLE LOCATIONS WITHIN CSJ LIMITS

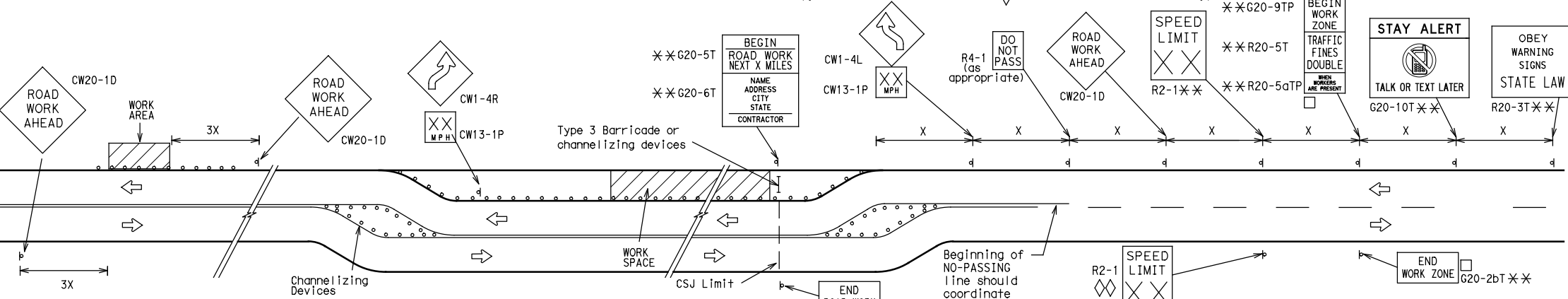

When extended distances occur between minimal work spaces, the Engineer/Inspector should ensure additional "ROAD WORK AHEAD" (CW20-1D) signs are placed in advance of these work areas to remind drivers they are still within the project limits. See the applicable TCP sheets for exact location and spacing of signs and channelizing devices.

SAMPLE LAYOUT OF SIGNING FOR WORK BEGINNING DOWNSTREAM OF THE CSJ LIMITS

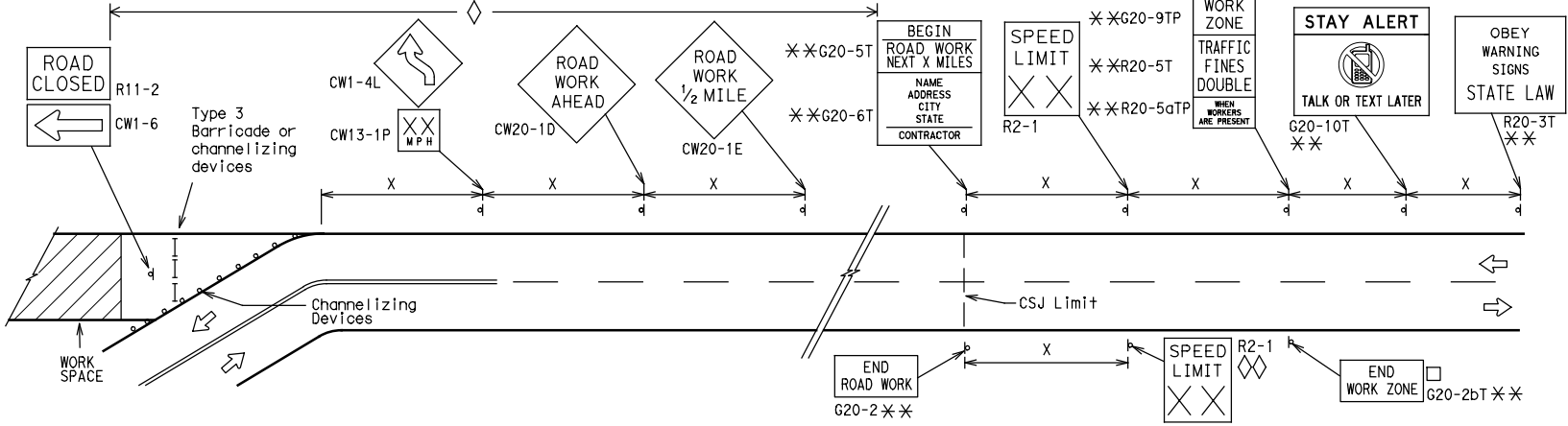

SAMPLE LAYOUT OF SIGNING FOR WORK BEGINNING AT THE CSJ LIMITS

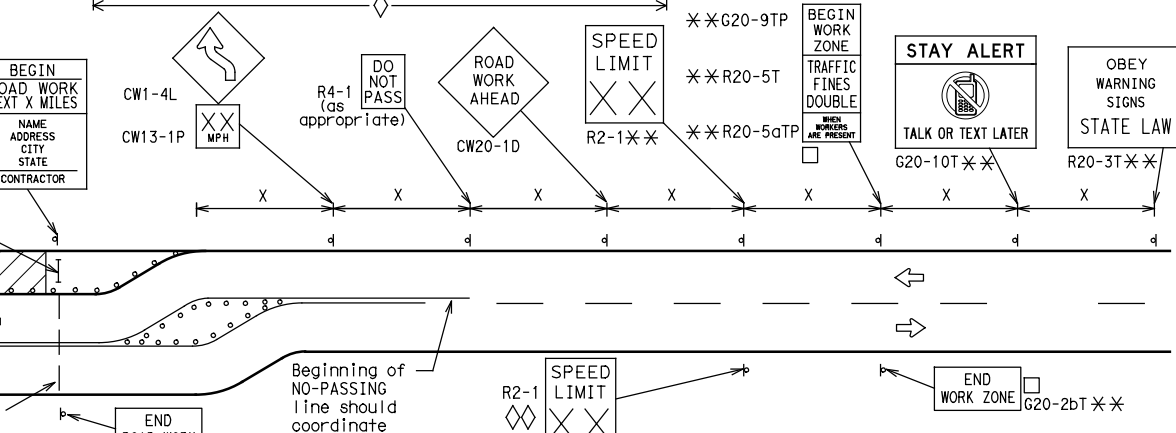

NOTES

- The Contractor shall determine the appropriate distance to be placed on the G20-1 series signs and "BEGIN ROAD WORK NEXT X MILES" (G20-5T) sign for each specific project. This distance shall replace the "X" and shall be rounded to the nearest whole mile with the approval of the Engineer. No decimals shall be used.
- The "BEGIN WORK ZONE" (G20-9TP) and "END WORK ZONE" (G20-2bT) shall be used as shown on the sample layout when advance signs are required outside the CSJ Limits. They inform the motorist of entering or leaving a part of the work zone lying outside the CSJ Limits where traffic fines may double if workers are present.
 - ** CSJ limit signing is required for highway construction and maintenance work, with the exception of mobile operations.
 - ◇ Area for placement of "ROAD WORK AHEAD" (CW20-1D) sign and other signs or devices as called for on the Traffic Control Plan.
 - ◇◇ Contractor will install a regulatory speed limit sign at the end of the work zone.

LEGEND

—	Type 3 Barricade
○ ○ ○	Channelizing Devices
■	Sign
X	See Typical Construction Warning Sign Size and Spacing chart or the TMUTCD for sign spacing requirements.

BARRICADE AND CONSTRUCTION PROJECT LIMIT

BC(2)-21

FILE: bc-21.dgn	DN: TxDOT	CK: TxDOT	DW: TxDOT	CK: TxDOT
© TxDOT November 2002	CONT	SECT	JOB	HIGHWAY
REVISIONS	091016		180	SH 64, Etc.
9-07 8-14	DIST	COUNTY		SHEET NO.
7-13 5-21	TYL	SMITH, Etc.		7

TYPICAL APPLICATION OF WORK ZONE SPEED LIMIT SIGNS

Work zone speed limits shall be regulatory, established in accordance with the "Procedures for Establishing Speed Zones," and approved by the Texas Transportation Commission, or by City Ordinance when within Incorporated City Limits.

Reduced speeds should only be posted in the vicinity of work activity and not throughout the entire project. Regulatory work zone speed signs (R2-1) shall be removed or covered during periods when they are not needed.

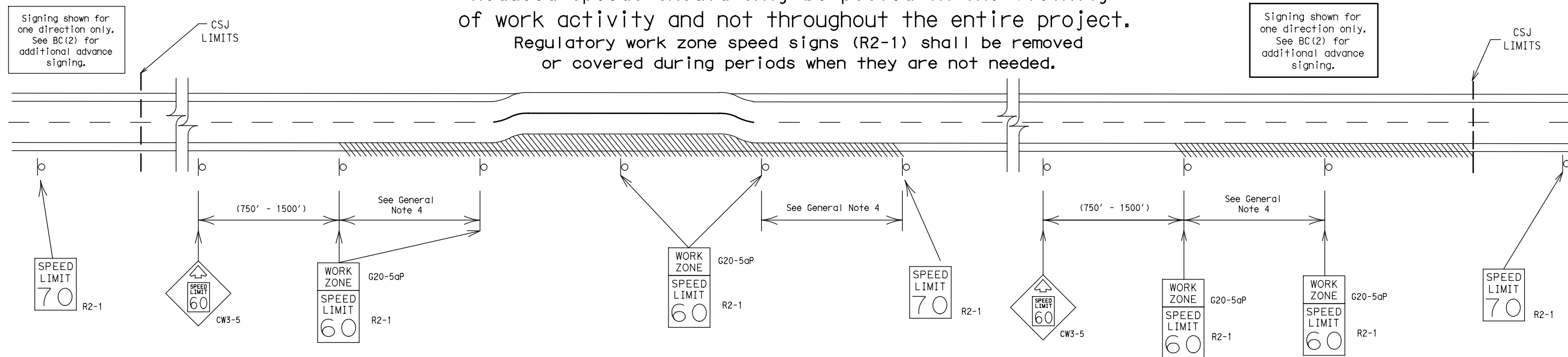

GUIDANCE FOR USE:

LONG/INTERMEDIATE TERM WORK ZONE SPEED LIMITS

This type of work zone speed limit should be included on the design of the traffic control plans when restricted geometrics with a lower design speed are present in the work zone and modification of the geometrics to a higher design speed is not feasible.

Long/Intermediate Term Work Zone Speed Limit signs, when approved as described above, should be posted and visible to the motorist when work activity is present. Work activity may also be defined as a change in the roadway that requires a reduced speed for motorists to safely negotiate the work area, including:

- rough road or damaged pavement surface
- substantial alteration of roadway geometrics (diversions)
- construction detours
- grade
- width
- other conditions readily apparent to the driver

As long as any of these conditions exist, the work zone speed limit signs should remain in place.

SHORT TERM WORK ZONE SPEED LIMITS

This type of work zone speed limit may be included on the design of the traffic control plans when workers or equipment are not behind concrete barrier, when work activity is within 10 feet of the traveled way or actually in the traveled way.

Short Term Work Zone Speed Limit signs should be posted and visible to the motorists only when work activity is present. When work activity is not present, signs shall be removed or covered. (See Removing or Covering on BC(4)).

GENERAL NOTES

- Regulatory work zone speed limits should be used only for sections of construction projects where speed control is of major importance.
- Regulatory work zone speed limit signs shall be placed on supports at a 7 foot minimum mounting height.
- Speed zone signs are illustrated for one direction of travel and are normally posted for each direction of travel.
- Frequency of work zone speed limit signs should be:

40 mph and greater	0.2 to 2 miles
35 mph and less	0.2 to 1 mile
- Regulatory speed limit signs shall have black legend and border on a white reflective background (See "Reflective Sheeting" on BC(4)).
- Fabrication, erection and maintenance of the "ADVANCE SPEED LIMIT" (CW3-5) sign, "WORK ZONE" (G20-5aP) plaque and the "SPEED LIMIT" (R2-1) signs shall not be paid for directly, but shall be considered subsidiary to Item 502.
- Turning signs from view, laying signs over or down will not be allowed, unless as otherwise noted under "REMOVING OR COVERING" on BC(4).
- Techniques that may help reduce traffic speeds include but are not limited to:
 - Law enforcement.
 - Flagger stationed next to sign.
 - Portable changeable message sign (PCMS).
 - Low-power (drone) radar transmitter.
 - Speed monitor trailers or signs.
- Speeds shown on details above are for illustration only. Work Zone Speed Limits should only be posted as approved for each project.
- For more specific guidance concerning the type of work, work zone conditions and factors impacting allowable regulatory construction speed zone reduction see TxDOT form #1204 in the TxDOT e-form system.

DISCLAIMER: The use of this standard is governed by the "Texas Engineering Practice Act". No warranty of any kind is made by TxDOT for any purpose whatsoever. TxDOT assumes no responsibility for the conversion of this standard to other formats or for incorrect results or damages resulting from its use.

DATE: 5/16/2024 9:30:38 AM
FILE: c:\pw-Infra\tech\in.zhang\dms47076\bc-21.dgn

SHEET 3 OF 12

		Texas Department of Transportation		Traffic Safety Division Standard
BARRICADE AND CONSTRUCTION WORK ZONE SPEED LIMIT				
BC (3) -21				
FILE:	bc-21.dgn	DN: TxDOT	CK: TxDOT	DW: TxDOT
© TxDOT	November 2002	CONT	SECT	JOB
REVISIONS		0910	16	180
9-07	8-14	DIST	COUNTY	SHEET NO.
7-13	5-21	TYL	SMITH, Etc.	8

DISCLAIMER: The use of this standard is governed by the "Texas Engineering Practice Act". No warranty of any kind is made by TxDOT for any purpose whatsoever. TxDOT assumes no responsibility for the conversion of this standard to other formats or for incorrect results or damages resulting from its use.

TYPICAL MINIMUM CLEARANCES FOR LONG TERM AND INTERMEDIATE TERM SIGNS

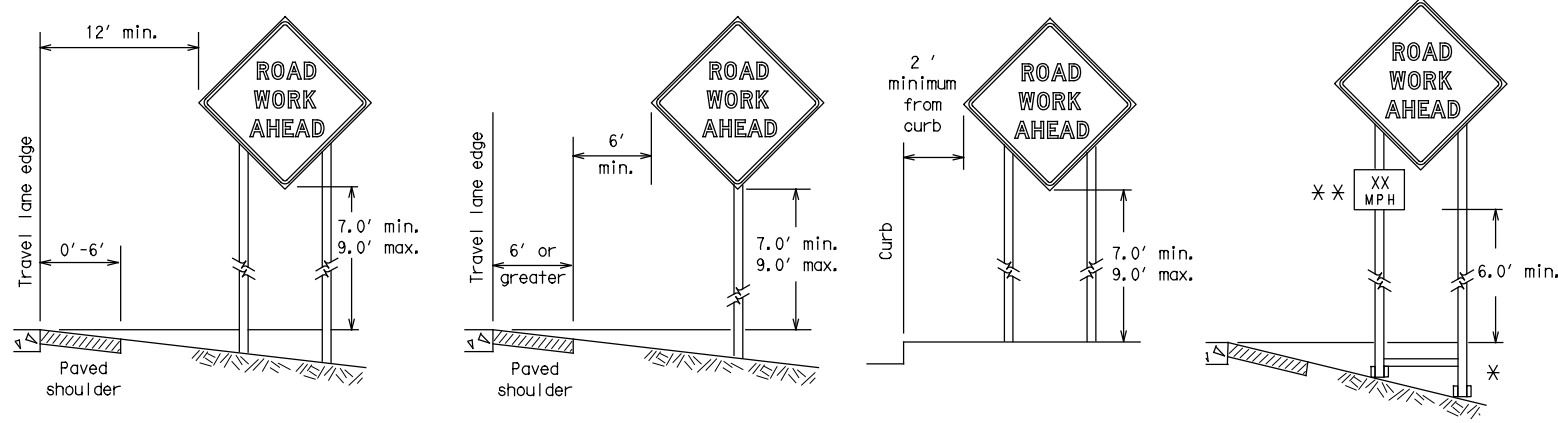

* When placing skid supports on unlevel ground, the leg post lengths must be adjusted so the sign appears straight and plumb. Objects shall NOT be placed under skids as a means of leveling.

** When plaques are placed on dual-leg supports, they should be attached to the upright nearest the travel lane. Supplemental plaques (advisory or distance) should not cover the surface of the parent sign.

ATTACHMENT FOR SIGN SUPPORTS

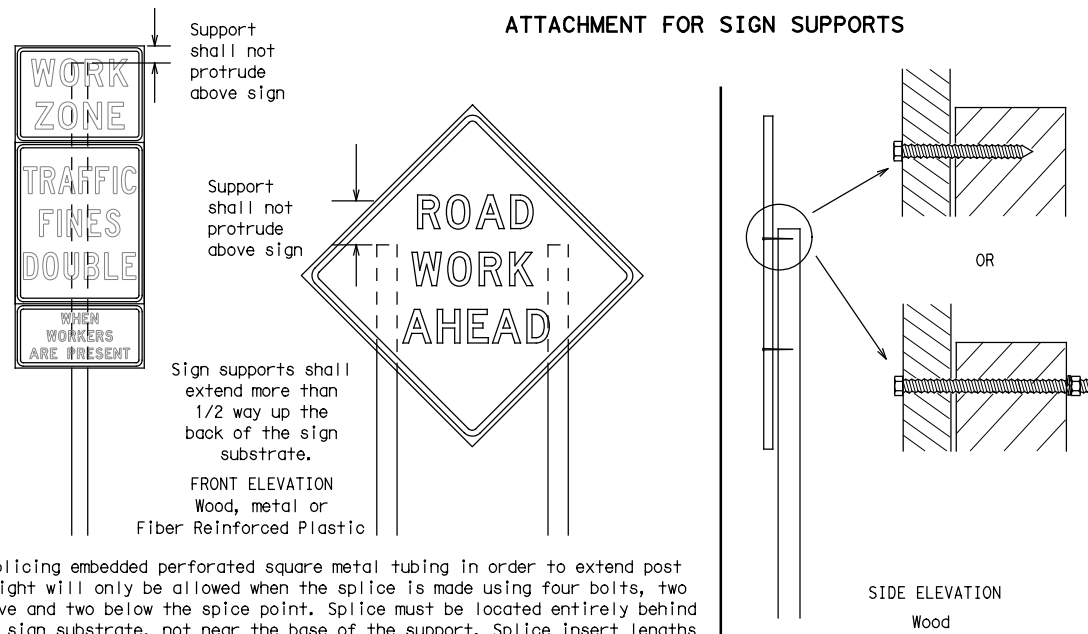

Splicing embedded perforated square metal tubing in order to extend post height will only be allowed when the splice is made using four bolts, two above and two below the splice point. Splice must be located entirely behind the sign substrate, not near the base of the support. Splice insert lengths should be at least 5 times nominal post size, centered on the splice and of at least the same gauge material.

GENERAL NOTES FOR WORK ZONE SIGNS

- Contractor shall install and maintain signs in a straight and plumb condition and/or as directed by the Engineer.
- Wooden sign posts shall be painted white.
- Barricades shall NOT be used as sign supports.
- All signs shall be installed in accordance with the plans or as directed by the Engineer. Signs shall be used to regulate, warn, and guide the traveling public safely through the work zone.
- The Contractor may furnish either the sign design shown in the plans or in the "Standard Highway Sign Designs for Texas" (SHSD). The Engineer/Inspector may require the Contractor to furnish other work zone signs that are shown in the TMUTCD but may have been omitted from the plans. Any variation in the plans shall be documented by written agreement between the Engineer and the Contractor's Responsible Person. All changes must be documented in writing before being implemented. This can include documenting the changes in the Inspector's TxDOT diary and having both the Inspector and Contractor initial and date the agreed upon changes.
- The Contractor shall furnish sign supports listed in the "Compliant Work Zone Traffic Control Device List" (CWZTCD) for small roadside signs. Supports for temporary large roadside signs shall meet the requirements detailed on the Temporary Large Roadside Signs (TLRS) standard sheets. The Contractor shall install the sign support in accordance with the manufacturer's recommendations. If there is a question regarding installation procedures, the Contractor shall furnish the Engineer a copy of the manufacturer's installation recommendations so the Engineer can verify the correct procedures are being followed.
- The Contractor is responsible for installing signs on approved supports and replacing signs with damaged or cracked substrates and/or damaged or marred reflective sheeting as directed by the Engineer/Inspector.
- Identification markings may be shown only on the back of the sign substrate. The maximum height of letters and/or company logos used for identification shall be 1 inch.
- The Contractor shall replace damaged wood posts. New or damaged wood sign posts shall not be spliced.

DURATION OF WORK (as defined by the "Texas Manual on Uniform Traffic Control Devices" Part 6)

- The types of sign supports, sign mounting height, the size of signs, and the type of sign substrates can vary based on the type of work being performed. The Engineer is responsible for selecting the appropriate size sign for the type of work being performed. The Contractor is responsible for ensuring the sign support, sign mounting height and substrate meets manufacturer's recommendations in regard to crashworthiness and duration of work requirements.
 - Long-term stationary - work that occupies a location more than 3 days.
 - Intermediate-term stationary - work that occupies a location more than one daylight period up to 3 days, or nighttime work lasting more than one hour.
 - Short-term stationary - daytime work that occupies a location for more than 1 hour in a single daylight period.
 - Short, duration - work that occupies a location up to 1 hour.
 - Mobile - work that moves continuously or intermittently (stopping for up to approximately 15 minutes.)

SIGN MOUNTING HEIGHT

- The bottom of Long-term/Intermediate-term signs shall be at least 7 feet, but not more than 9 feet, above the paved surface, except as shown for supplemental plaques mounted below other signs.
- The bottom of Short-term/Short Duration signs shall be a minimum of 1 foot above the pavement surface but no more than 2 feet above the ground.
- Long-term/Intermediate-term Signs may be used in lieu of Short-term/Short Duration signing.
- Short-term/Short Duration signs shall be used only during daylight and shall be removed at the end of the workday or raised to appropriate Long-term/Intermediate sign height.
- Regulatory signs shall be mounted at least 7 feet, but not more than 9 feet, above the paved surface regardless of work duration.

SIZE OF SIGNS

- The Contractor shall furnish the sign sizes shown on BC (2) unless otherwise shown in the plans or as directed by the Engineer.

SIGN SUBSTRATES

- The Contractor shall ensure the sign substrate is installed in accordance with the manufacturer's recommendations for the type of sign support that is being used. The CWZTCD lists each substrate that can be used on the different types and models of sign supports.
- "Mesh" type materials are NOT an approved sign substrate, regardless of the tightness of the weave.
- All wooden individual sign panels fabricated from 2 or more pieces shall have one or more plywood cleat, 1/2" thick by 6" wide, fastened to the back of the sign and extending fully across the sign. The cleat shall be attached to the back of the sign using wood screws that do not penetrate the face of the sign panel. The screws shall be placed on both sides of the splice and spaced at 6" centers. The Engineer may approve other methods of splicing the sign face.

REFLECTIVE SHEETING

- All signs shall be retroreflective and constructed of sheeting meeting the color and retro-reflectivity requirements of DMS-8300 for rigid signs or DMS-8310 for roll-up signs. The web address for DMS specifications is shown on BC(1).
- White sheeting, meeting the requirements of DMS-8300 Type A, shall be used for signs with a white background.
- Orange sheeting, meeting the requirements of DMS-8300 Type B_{FL} or Type C_{FL}, shall be used for rigid signs with orange backgrounds.

SIGN LETTERS

- All sign letters and numbers shall be clear, and open rounded type uppercase alphabet letters as approved by the Federal Highway Administration (FHWA) and as published in the "Standard Highway Sign Design for Texas" manual. Signs, letters and numbers shall be of first class workmanship in accordance with Department Standards and Specifications.

REMOVING OR COVERING

- When sign messages may be confusing or do not apply, the signs shall be removed or completely covered.
- Long-term stationary or intermediate stationary signs installed on square metal tubing may be turned away from traffic 90 degrees when the sign message is not applicable. This technique may not be used for signs installed in the median of divided highways or near any intersections where the sign may be seen from approaching traffic.
- Signs installed on wooden skids shall not be turned at 90 degree angles to the roadway. These signs should be removed or completely covered when not required.
- When signs are covered, the material used shall be opaque, such as heavy mil black plastic, or other materials which will cover the entire sign face and maintain their opaque properties under automobile headlights at night, without damaging the sign sheeting.
- Burlap shall NOT be used to cover signs.
- Duct tape or other adhesive material shall NOT be affixed to a sign face.
- Signs and anchor stubs shall be removed and holes backfilled upon completion of work.

SIGN SUPPORT WEIGHTS

- Where sign supports require the use of weights to keep from turning over, the use of sandbags with dry, cohesionless sand should be used.
- The sandbags will be tied shut to keep the sand from spilling and to maintain a constant weight.
- Rock, concrete, iron, steel or other solid objects shall not be permitted for use as sign support weights.
- Sandbags should weigh a minimum of 35 lbs and a maximum of 50 lbs.
- Sandbags shall be made of a durable material that tears upon vehicular impact. Rubber (such as tire inner tubes) shall NOT be used.
- Rubber ballasts designed for channelizing devices should not be used for ballast on portable sign supports. Sign supports designed and manufactured with rubber bases may be used when shown on the CWZTCD list.
- Sandbags shall only be placed along or laid over the base supports of the traffic control device and shall not be suspended above ground level or hung with rope, wire, chains or other fasteners. Sandbags shall be placed along the length of the skids to weigh down the sign support.
- Sandbags shall NOT be placed under the skid and shall not be used to level sign supports placed on slopes.

FLAGS ON SIGNS

- Flags may be used to draw attention to warning signs. When used, the flag shall be 16 inches square or larger and shall be orange or fluorescent red-orange in color. Flags shall not be allowed to cover any portion of the sign face.

STOP/SLOW PADDLES

- STOP/SLOW paddles are the primary method to control traffic by flaggers. The STOP/SLOW paddle size should be 24" x 24".
- STOP/SLOW paddles shall be retroreflectORIZED when used at night.
- STOP/SLOW paddles may be attached to a staff with a minimum length of 6' to the bottom of the sign.
- Any lights incorporated into the STOP or SLOW paddle faces shall only be as specifically described in Section 6E.03 Hand Signaling Devices in the TMUTCD.

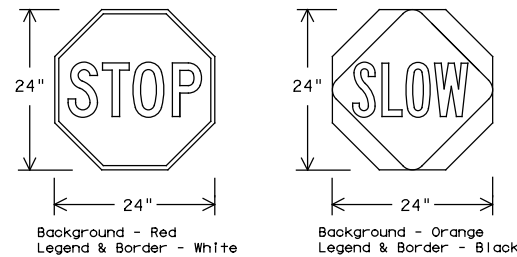

SHEETING REQUIREMENTS (WHEN USED AT NIGHT)		
USAGE	COLOR	SIGN FACE MATERIAL
BACKGROUND	RED	TYPE B OR C SHEETING
BACKGROUND	ORANGE	TYPE B _{FL} OR C _{FL} SHEETING
LEGEND & BORDER	WHITE	TYPE B OR C SHEETING
LEGEND & BORDER	BLACK	ACRYLIC NON-REFLECTIVE FILM

CONTRACTOR REQUIREMENTS FOR MAINTAINING PERMANENT SIGNS WITHIN THE PROJECT LIMITS

- Permanent signs are used to give notice of traffic laws or regulations, call attention to conditions that are potentially hazardous to traffic operations, show route designations, destinations, directions, distances, services, points of interest, and other geographical, recreational, specific service (LOGO), or cultural information. Drivers proceeding through a work zone need the same, if not better route guidance as normally installed on a roadway without construction.
- When permanent regulatory or warning signs conflict with work zone conditions, remove or cover the permanent signs until the permanent sign message matches the roadway condition. For details for covering large guide signs see the TS-CD standard.
- When existing permanent signs are moved and relocated due to construction purposes, they shall be visible to motorists at all times.
- If existing signs are to be relocated on their original supports, they shall be installed on crashworthy bases as shown on the SMD Standard sheets. The signs shall meet the required mounting heights shown on the BC Sheets or the SMD Standards. This work should be paid for under the appropriate pay item for relocating existing signs.
- If permanent signs are to be removed and relocated using temporary supports, the Contractor shall use crashworthy supports as shown on the BC standard sheets, TLRS standard sheets or the CWZTCD list. The signs shall meet the required mounting heights shown on the BC, or the SMD standard sheets during construction. This work should be paid for under the appropriate pay item for relocating existing signs.
- Any sign or traffic control device that is struck or damaged by the Contractor or his/her construction equipment shall be replaced as soon as possible by the Contractor to ensure proper guidance for the motorists. This will be subsidiary to Item 502.

SHEET 4 OF 12



BARRICADE AND CONSTRUCTION TEMPORARY SIGN NOTES

BC (4) -21

FILE:	bc-21.dgn	DN:	TxDOT	CK:	TxDOT	OW:	TxDOT	CK:	TxDOT
© TxDOT	November 2002	CONT	SECT	JOB	HIGHWAY				
REVISIONS		0910	16	180	SH 64, Etc.				
9-07	8-14	DIST	COUNTY		SHEET NO.				
7-13	5-21	TYL	SMITH, Etc.		9				

DATE: 5/16/2024 9:30:38 AM
FILE: c:\pw-inf\fratex\in.zhang\dms47076\bc-21.dgn

DISCLAIMER: The use of this standard is governed by the "Texas Engineering Practice Act". No warranty of any kind is made by TxDOT for any purpose whatsoever. TxDOT assumes no responsibility for the conversion of this standard to other formats or for incorrect results or damages resulting from its use.

DATE: 5/16/2024 9:30:38 AM
 FILE: c:\pw-inf\fractech\in.zhang\dms47076\bc-21.dgn

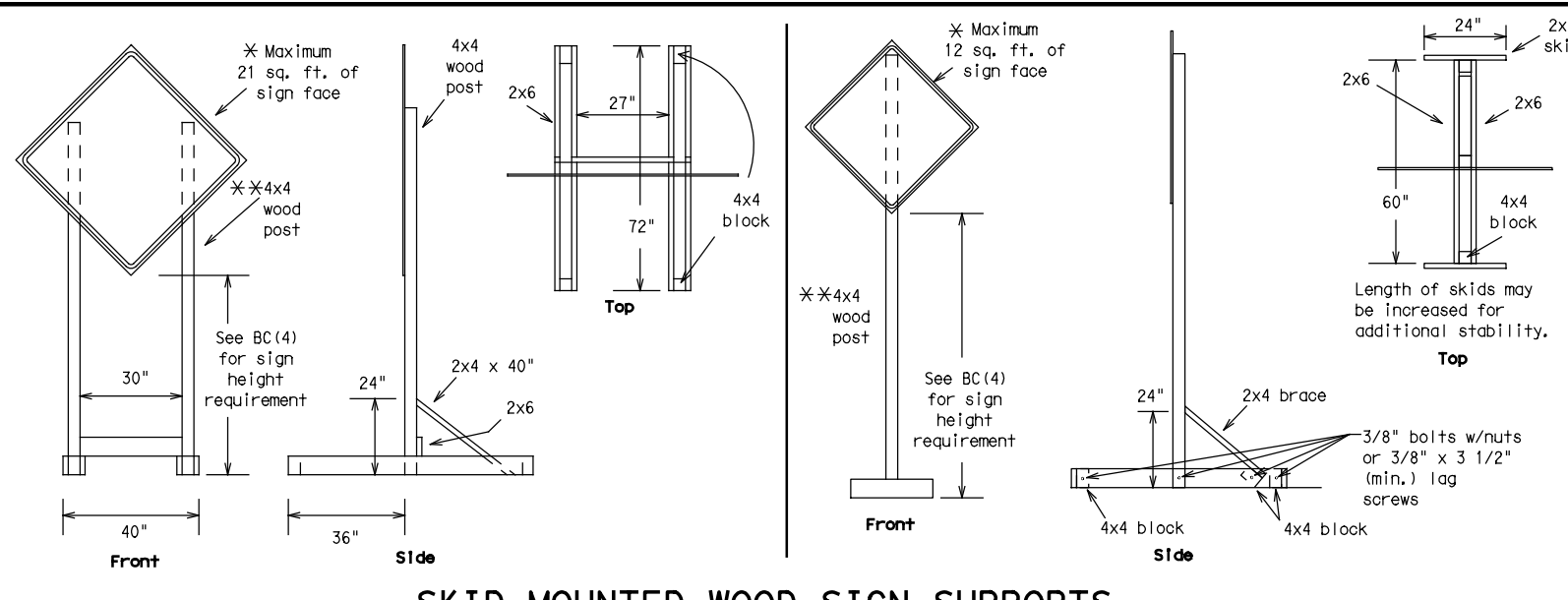

SKID MOUNTED WOOD SIGN SUPPORTS

* LONG/INTERMEDIATE TERM STATIONARY - PORTABLE SKID MOUNTED SIGN SUPPORTS

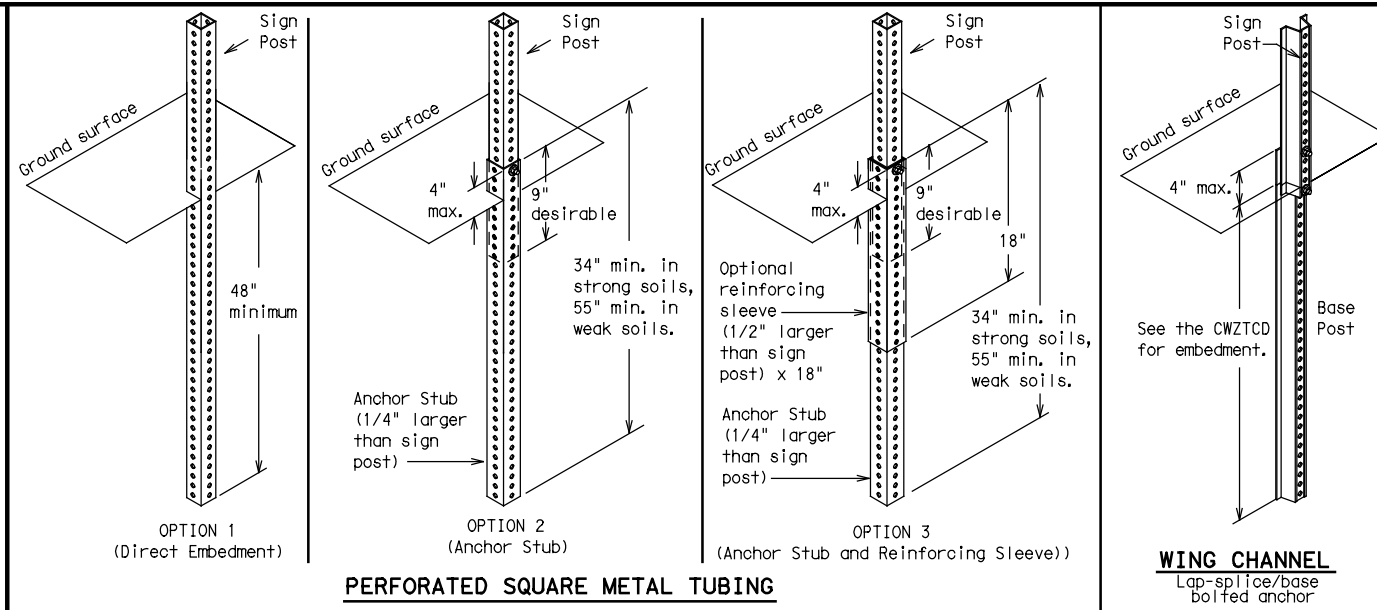

GROUND MOUNTED SIGN SUPPORTS

Refer to the CWZTCD and the manufacturer's installation procedure for each type sign support. The maximum sign square footage shall adhere to the manufacturer's recommendation. Two post installations can be used for larger signs.

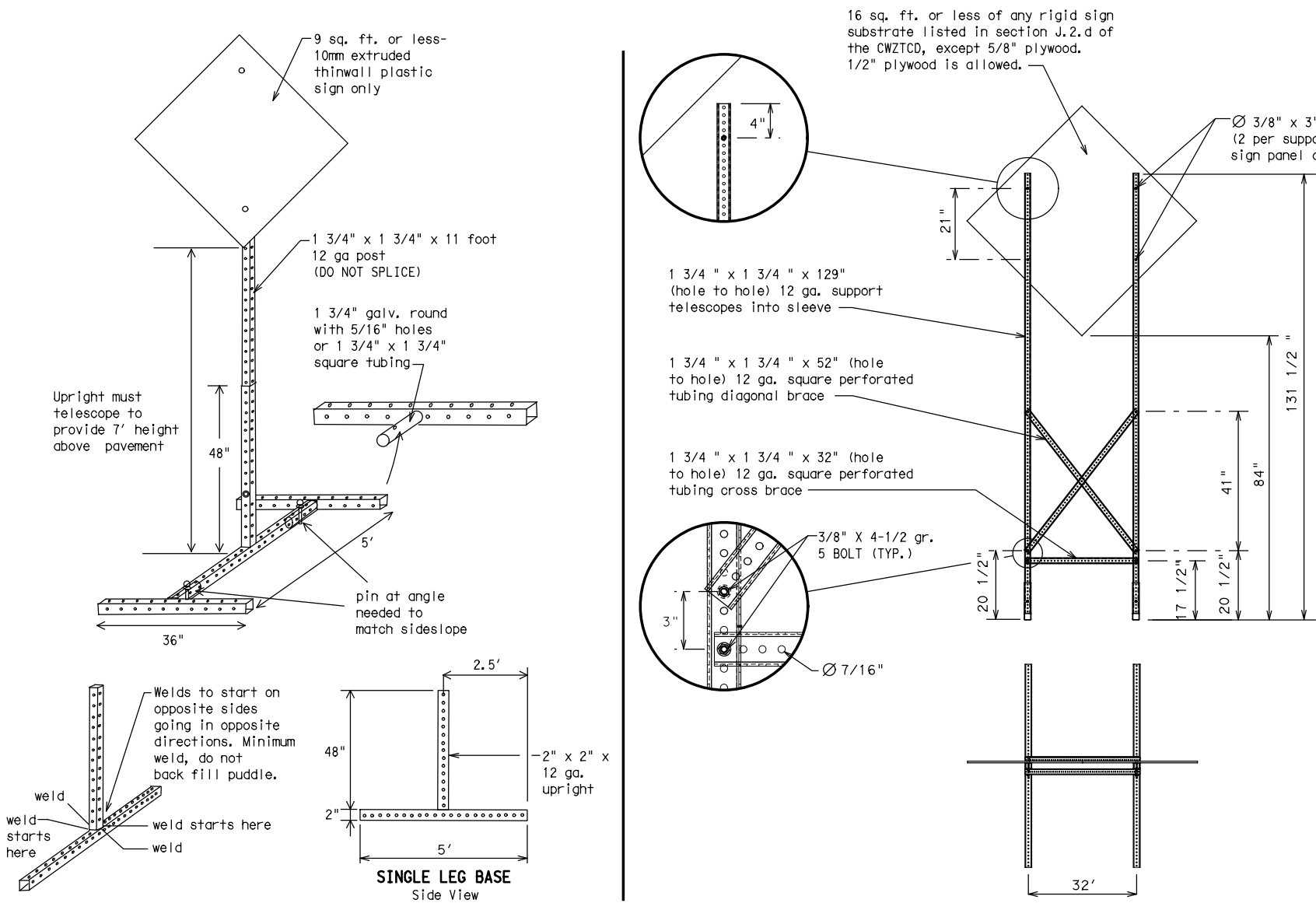

SKID MOUNTED PERFORATED SQUARE STEEL TUBING SIGN SUPPORTS

* LONG/INTERMEDIATE TERM STATIONARY - PORTABLE SKID MOUNTED SIGN SUPPORTS

WEDGE ANCHORS

Both steel and plastic Wedge Anchor Systems as shown on the SMD Standard Sheets may be used as temporary sign supports for signs up to 10 square feet of sign face. They may be set in concrete or in sturdy soils if approved by the Engineer. (See web address for "Traffic Engineering Standard Sheets" on BC(1)).

OTHER DESIGNS

MORE DETAILS OF APPROVED LONG/INTERMEDIATE AND SHORT TERM SUPPORTS CAN BE FOUND ON THE CWZTCD LIST. SEE BC(1) FOR WEBSITE LOCATION.

GENERAL NOTES

1. Nails may be used in the assembly of wooden sign supports, but 3/8" bolts with nuts or 3/8" x 3 1/2" lag screws must be used on every joint for final connection.
2. No more than 2 sign posts shall be placed within a 7 ft. circle, except for specific materials noted on the CWZTCD List.
3. When project is completed, all sign supports and foundations shall be removed from the project site. This will be considered subsidiary to Item 502.

- * See BC(4) for definition of "Work Duration."
- ** Wood sign posts MUST be one piece. Splicing will NOT be allowed. Posts shall be painted white.
- See the CWZTCD for the type of sign substrate that can be used for each approved sign support.

SHEET 5 OF 12



BARRICADE AND CONSTRUCTION TYPICAL SIGN SUPPORT

BC(5)-21

FILE: bc-21.dgn	DN: TxDOT	CK: TxDOT	DW: TxDOT	CK: TxDOT
© TxDOT November 2002	CONT	SECT	JOB	HIGHWAY
REVISIONS	0910	16	180	SH 64, Etc.
9-07 8-14	DIST	COUNTY	SHEET NO.	
7-13 5-21	TYL	SMITH, Etc.	10	

WHEN NOT IN USE, REMOVE THE PCMS FROM THE RIGHT-OF-WAY OR PLACE THE PCMS BEHIND BARRIER OR GUARDRAIL WITH SIGN PANEL TURNED PARALLEL TO TRAFFIC

RECOMMENDED PHASES AND FORMATS FOR PCMS MESSAGES DURING ROADWORK ACTIVITIES

(The Engineer may approve other messages not specifically covered here.)

PORTABLE CHANGEABLE MESSAGE SIGNS

- The Engineer/Inspector shall approve all messages used on portable changeable message signs (PCMS).
- Messages on PCMS should contain no more than 8 words (about four to eight characters per word), not including simple words such as "TO," "FOR," "AT," etc.
- Messages should consist of a single phase, or two phases that alternate. Three-phase messages are not allowed. Each phase of the message should convey a single thought, and must be understood by itself.
- Use the word "EXIT" to refer to an exit ramp on a freeway; i.e., "EXIT CLOSED." Do not use the term "RAMP."
- Always use the route or interstate designation (IH, US, SH, FM) along with the number when referring to a roadway.
- When in use, the bottom of a stationary PCMS message panel should be a minimum 7 feet above the roadway, where possible.
- The message term "WEEKEND" should be used only if the work is to start on Saturday morning and end by Sunday evening at midnight. Actual days and hours of work should be displayed on the PCMS if work is to begin on Friday evening and/or continue into Monday morning.
- The Engineer/Inspector may select one of two options which are available for displaying a two-phase message on a PCMS. Each phase may be displayed for either four seconds each or for three seconds each.
- Do not "flash" messages or words included in a message. The message should be steady burn or continuous while displayed.
- Do not present redundant information on a two-phase message; i.e., keeping two lines of the message the same and changing the third line.
- Do not use the word "Danger" in message.
- Do not display the message "LANES SHIFT LEFT" or "LANES SHIFT RIGHT" on a PCMS. Drivers do not understand the message.
- Do not display messages that scroll horizontally or vertically across the face of the sign.
- The following table lists abbreviated words and two-word phrases that are acceptable for use on a PCMS. Both words in a phrase must be displayed together. Words or phrases not on this list should not be abbreviated, unless shown in the TMUTCD.
- PCMS character height should be at least 18 inches for trailer mounted units. They should be visible from at least 1/2 (.5) mile and the text should be legible from at least 600 feet at night and 800 feet in daylight. Truck mounted units must have a character height of 10 inches and must be legible from at least 400 feet.
- Each line of text should be centered on the message board rather than left or right justified.
- If disabled, the PCMS should default to an illegible display that will not alarm motorists and will only be used to alert workers that the PCMS has malfunctioned. A pattern such as a series of horizontal solid bars is appropriate.

Phase 1: Condition Lists

Road/Lane/Ramp Closure List

FREEWAY CLOSED X MILE	FRONTAGE ROAD CLOSED
ROAD CLOSED AT SH XXX	SHOULDER CLOSED XXX FT
ROAD CLSD AT FM XXXX	RIGHT LN CLOSED XXX FT
RIGHT X LANES CLOSED	RIGHT X LANES OPEN
CENTER LANE CLOSED	DAYTIME LANE CLOSURES
NIGHT LANE CLOSURES	I-XX SOUTH EXIT CLOSED
VARIOUS LANES CLOSED	EXIT XXX CLOSED X MILE
EXIT CLOSED	RIGHT LN TO BE CLOSED
MALL DRIVEWAY CLOSED	X LANES CLOSED TUE - FRI
XXXXXXXXX BLVD CLOSED	

Other Condition List

ROADWORK XXX FT	ROAD REPAIRS XXXX FT
FLAGGER XXXX FT	LANE NARROWS XXXX FT
RIGHT LN NARROWS XXXX FT	TWO-WAY TRAFFIC XX MILE
MERGING TRAFFIC XXXX FT	CONST TRAFFIC XXX FT
LOOSE GRAVEL XXXX FT	UNEVEN LANES XXXX FT
DETOUR X MILE	ROUGH ROAD XXXX FT
ROADWORK PAST SH XXXX	ROADWORK NEXT FRI-SUN
BUMP XXXX FT	US XXX EXIT X MILES
TRAFFIC SIGNAL XXXX FT	LANES SHIFT *

* LANES SHIFT in Phase 1 must be used with STAY IN LANE in Phase 2.

Phase 2: Possible Component Lists

Action to Take/Effect on Travel List

MERGE RIGHT	FORM X LINES RIGHT
DETOUR NEXT X EXITS	USE XXXXX RD EXIT
USE EXIT XXX	USE EXIT I-XX NORTH
STAY ON US XXX SOUTH	USE I-XX E TO I-XX N
TRUCKS USE US XXX N	WATCH FOR TRUCKS
WATCH FOR TRUCKS	EXPECT DELAYS
EXPECT DELAYS	PREPARE TO STOP
REDUCE SPEED XXX FT	END SHOULDER USE
USE OTHER ROUTES	WATCH FOR WORKERS
STAY IN LANE *	

Location List

AT FM XXXX
BEFORE RAILROAD CROSSING
NEXT X MILES
PAST US XXX EXIT
XXXXXXXXX TO XXXXXXXX
US XXX TO FM XXXX

Warning List

SPEED LIMIT XX MPH
MAXIMUM SPEED XX MPH
MINIMUM SPEED XX MPH
ADVISORY SPEED XX MPH
RIGHT LANE EXIT
USE CAUTION
DRIVE SAFELY
DRIVE WITH CARE

** Advance Notice List

TUE-FRI XX AM-X PM
APR XX-XX X PM-X AM
BEGINS MONDAY
BEGINS MAY XX
MAY X-X XX PM - XX AM
NEXT FRI-SUN
XX AM TO XX PM
NEXT TUE AUG XX
TONIGHT XX PM-XX AM

** See Application Guidelines Note 6.

APPLICATION GUIDELINES

- Only 1 or 2 phases are to be used on a PCMS.
- The 1st phase (or both) should be selected from the "Road/Lane/Ramp Closure List" and the "Other Condition List".
- A 2nd phase can be selected from the "Action to Take/Effect on Travel, Location, General Warning, or Advance Notice Phase Lists".
- A Location Phase is necessary only if a distance or location is not included in the first phase selected.
- If two PCMS are used in sequence, they must be separated by a minimum of 1000 ft. Each PCMS shall be limited to two phases, and should be understandable by themselves.
- For advance notice, when the current date is within seven days of the actual work date, calendar days should be replaced with days of the week. Advance notification should typically be for no more than one week prior to the work.

WORDING ALTERNATIVES

- The words RIGHT, LEFT and ALL can be interchanged as appropriate.
- Roadway designations IH, US, SH, FM and LP can be interchanged as appropriate.
- EAST, WEST, NORTH and SOUTH (or abbreviations E, W, N and S) can be interchanged as appropriate.
- Highway names and numbers replaced as appropriate.
- ROAD, HIGHWAY and FREEWAY can be interchanged as needed.
- AHEAD may be used instead of distances if necessary.
- FT and MI, MILE and MILES interchanged as appropriate.
- AT, BEFORE and PAST interchanged as needed.
- Distances or AHEAD can be eliminated from the message if a location phase is used.

PCMS SIGNS WITHIN THE R.O.W. SHALL BE BEHIND GUARDRAIL OR CONCRETE BARRIER OR SHALL HAVE A MINIMUM OF FOUR (4) PLASTIC DRUMS PLACED PERPENDICULAR TO TRAFFIC ON THE UPSTREAM SIDE OF THE PCMS, WHEN EXPOSED TO ONE DIRECTION OF TRAFFIC. WHEN EXPOSED TO TWO WAY TRAFFIC, THE FOUR DRUMS SHOULD BE PLACED WITH ONE DRUM AT EACH OF THE FOUR CORNERS OF THE UNIT.

FULL MATRIX PCMS SIGNS

- When Full Matrix PCMS signs are used, the character height and legibility/visibility requirements shall be maintained as listed in Note 15 under "PORTABLE CHANGEABLE MESSAGE SIGNS" above.
- When symbol signs, such as the "Flagger Symbol" (CW20-7) are represented graphically on the Full Matrix PCMS sign and, with the approval of the Engineer, it shall maintain the legibility/visibility requirement listed above.
- When symbol signs are represented graphically on the Full Matrix PCMS, they shall only supplement the use of the static sign represented, and shall not substitute for, or replace that sign.
- A full matrix PCMS may be used to simulate a flashing arrow board provided it meets the visibility, flash rate and dimming requirements on BC(7), for the same size arrow.

WORD OR PHRASE	ABBREVIATION	WORD OR PHRASE	ABBREVIATION
Access Road	ACCS RD	Major	MAJ
Alternate	ALT	Miles	MI
Avenue	AVE	Miles Per Hour	MPH
Best Route	BEST RTE	Minor	MNR
Boulevard	BLVD	Monday	MON
Bridge	BRDG	Normal	NORM
Cannot	CANT	North	N
Center	CTR	Northbound	(route) N
Construction Ahead	CONST AHD	Parking	PKING
CROSSING	XING	Road	RD
Detour Route	DETOUR RTE	Right Lane	RT LN
Do Not	DONT	Saturday	SAT
East	E	Service Road	SERV RD
Eastbound	(route) E	Shoulder	SHLDR
Emergency	EMER	Slippery	SLIP
Emergency Vehicle	EMER VEH	South	S
Entrance, Enter	ENT	Southbound	(route) S
Express Lane	EXP LN	Speed	SPD
Expressway	EXPWY	Street	ST
XXXX Feet	XXXX FT	Sunday	SUN
Fog Ahead	FOG AHD	Telephone	PHONE
Freeway	FRWY, FWY	Temporary	TEMP
Freeway Blocked	FWY BLKD	Thursday	THURS
Friday	FRI	To Downtown	TO DWNTN
Hazardous Driving	HAZ DRIVING	Traffic	TRAF
Hazardous Material	HAZMAT	Travelers	TRVLR
High-Occupancy Vehicle	HOV	Tuesday	TUES
Highway	HWY	Time Minutes	TIME MIN
Hour(s)	HR, HRS	Upper Level	UPR LEVEL
Information	INFO	Vehicles (s)	VEH, VEHS
It Is	ITS	Warning	WARN
Junction	JCT	Wednesday	WED
Left	LFT	Weight Limit	WT LIMIT
Left Lane	LFT LN	West	W
Lane Closed	LN CLOSED	Westbound	(route) W
Lower Level	LWR LEVEL	Wet Pavement	WET PVMT
Maintenance	MAINT	Will Not	WONT

Roadway designation # IH-number, US-number, SH-number, FM-number



BARRICADE AND CONSTRUCTION PORTABLE CHANGEABLE MESSAGE SIGN (PCMS)

BC (6) -21

FILE: bc-21.dgn	DN: TxDOT	CK: TxDOT	DW: TxDOT	CK: TxDOT
© TxDOT November 2002	CONT	SECT	JOB	HIGHWAY
REVISIONS	091016	180	SH 64, Etc.	
9-07 8-14	DIST	COUNTY	SHEET NO.	
7-13 5-21	TYL	SMITH, Etc.	11	

DISCLAIMER: The use of this standard is governed by the "Texas Engineering Practice Act". No warranty of any kind is made by TxDOT for any purpose whatsoever. TxDOT assumes no responsibility for the conversion of this standard to other formats or for incorrect results or damages resulting from its use.

DATE: 5/16/2024 9:30:38 AM
FILE: c:\pw-inf\tech\in.zhang\dms47076\bc-21.dgn

DISCLAIMER: The use of this standard is governed by the "Texas Engineering Practice Act". No warranty of any kind is made by TxDOT for any purpose whatsoever. TxDOT assumes no responsibility for the conversion of this standard to other formats or for incorrect results or damages resulting from its use.

- Barrier Reflectors shall be pre-qualified, and conform to the color and reflectivity requirements of DMS-8600. A list of prequalified Barrier Reflectors can be found at the Material Producer List web address shown on BC(1).
- Color of Barrier Reflectors shall be as specified in the TMUTCD. The cost of the reflectors shall be considered subsidiary to Item 512.

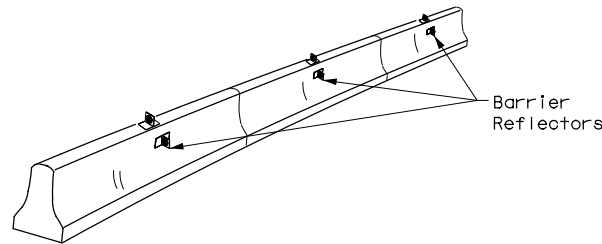

CONCRETE TRAFFIC BARRIER (CTB)

- Where traffic is on one side of the CTB, two (2) Barrier Reflectors shall be mounted in approximately the midsection of each section of CTB. An alternate mounting location is uniformly spaced at one end of each CTB. This will allow for attachment of a barrier grapple without damaging the reflector. The Barrier Reflector mounted on the side of the CTB shall be located directly below the reflector mounted on top of the barrier, as shown in the detail above.
- Where CTB separates two-way traffic, three barrier reflectors shall be mounted on each section of CTB. The reflector unit on top shall have two yellow reflective faces (Bi-Directional) while the reflectors on each side of the barrier shall have one yellow reflective face, as shown in the detail above.
- When CTB separates traffic traveling in the same direction, no barrier reflectors will be required on top of the CTB.
- Barrier Reflector units shall be yellow or white in color to match the edgeline being supplemented.
- Maximum spacing of Barrier Reflectors is forty (40) feet.
- Pavement markers or temporary flexible-reflective roadway marker tabs shall NOT be used as CTB delineation.
- Attachment of Barrier Reflectors to CTB shall be per manufacturer's recommendations.
- Missing or damaged Barrier Reflectors shall be replaced as directed by the Engineer.
- Single slope barriers shall be delineated as shown on the above detail.

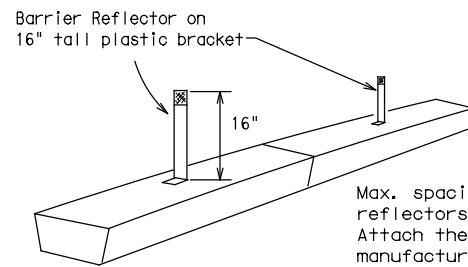

LOW PROFILE CONCRETE BARRIER (LPCB) USED IN WORK ZONES

LPCB is approved for use in work zone locations, where the posted speed is 45mph, or less. See Roadway Standard Sheet LPCB.

Max. spacing of barrier reflectors is 20 feet. Attach the delineators as per manufacturer's recommendations.

LOW PROFILE CONCRETE BARRIER (LPCB)

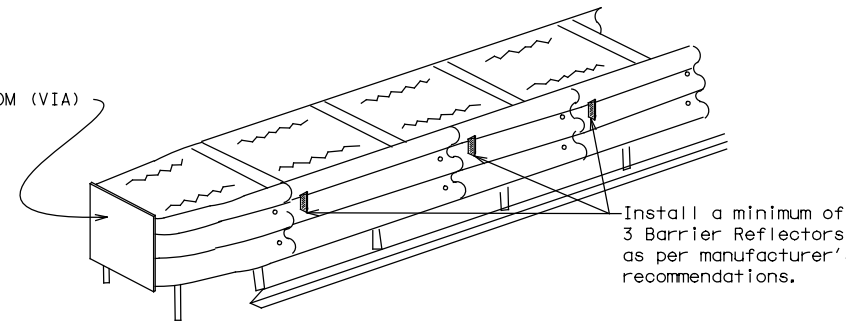

DELINEATION OF END TREATMENTS

END TREATMENTS FOR CTB'S USED IN WORK ZONES

End treatments used on CTB's in work zones shall meet the appropriate crashworthy standards as defined in the Manual for Assessing Safety Hardware (MASH). Refer to the CWZTCD List for approved end treatments and manufacturers.

BARRIER REFLECTORS FOR CONCRETE TRAFFIC BARRIER AND ATTENUATORS

WARNING LIGHTS

- Warning lights shall meet the requirements of the TMUTCD.
- Warning lights shall NOT be installed on barricades.
- Type A-Low Intensity Flashing Warning Lights are commonly used with drums. They are intended to warn of or mark a potentially hazardous area. Their use shall be as indicated on this sheet and/or other sheets of the plans by the designation "FL". The Type A Warning Lights shall not be used with signs manufactured with Type B_{FL} or C_{FL} Sheeting meeting the requirements of Departmental Material Specification DMS-8300.
- Type-C and Type D 360 degree Steady Burn Lights are intended to be used in a series for delineation to supplement other traffic control devices. Their use shall be as indicated on this sheet and/or other sheets of the plans by the designation "SB".
- The Engineer/Inspector or the plans shall specify the location and type of warning lights to be installed on the traffic control devices.
- When required by the Engineer, the Contractor shall furnish a copy of the warning lights certification. The warning light manufacturer will certify the warning lights meet the requirements of the latest ITE Purchase Specifications for Flashing and Steady-Burn Warning Lights.
- When used to delineate curves, Type-C and Type D Steady Burn Lights should only be placed on the outside of the curve, not the inside.
- The location of warning lights and warning reflectors on drums shall be as shown elsewhere in the plans.

WARNING LIGHTS MOUNTED ON PLASTIC DRUMS

- Type A flashing warning lights are intended to warn drivers that they are approaching or are in a potentially hazardous area.
- Type A random flashing warning lights are not intended for delineation and shall not be used in a series.
- A series of sequential flashing warning lights placed on channelizing devices to form a merging taper may be used for delineation. If used, the successive flashing of the sequential warning lights should occur from the beginning of the taper to the end of the merging taper in order to identify the desired vehicle path. The rate of flashing for each light shall be 65 flashes per minute, plus or minus 10 flashes.
- Type C and D steady-burn warning lights are intended to be used in a series to delineate the edge of the travel lane on detours, on lane changes, on lane closures, and on other similar conditions.
- Type A, Type C and Type D warning lights shall be installed at locations as detailed on other sheets in the plans.
- Warning lights shall not be installed on a drum that has a sign, chevron or vertical panel.
- The maximum spacing for warning lights on drums should be identical to the channelizing device spacing.

WARNING REFLECTORS MOUNTED ON PLASTIC DRUMS AS A SUBSTITUTE FOR TYPE C (STEADY BURN) WARNING LIGHTS

- A warning reflector or approved substitute may be mounted on a plastic drum as a substitute for a Type C, steady burn warning light at the discretion of the Contractor unless otherwise noted in the plans.
- The warning reflector shall be yellow in color and shall be manufactured using a sign substrate approved for use with plastic drums listed on the CWZTCD.
- The warning reflector shall have a minimum retroreflective surface area (one-side) of 30 square inches.
- Round reflectors shall be fully reflectorized, including the area where attached to the drum.
- Square substrates must have a minimum of 30 square inches of reflectorized sheeting. They do not have to be reflectorized where it attaches to the drum.
- The side of the warning reflector facing approaching traffic shall have sheeting meeting the color and retroreflectivity requirements for DMS 8300-Type B or Type C.
- When used near two-way traffic, both sides of the warning reflector shall be reflectorized.
- The warning reflector should be mounted on the side of the handle nearest approaching traffic.
- The maximum spacing for warning reflectors should be identical to the channelizing device spacing requirements.

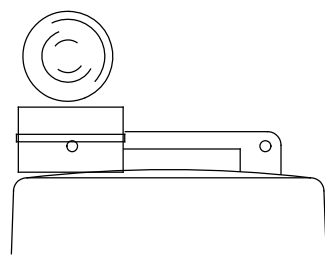

Type C Warning Light or approved substitute mounted on a drum adjacent to the travel way.

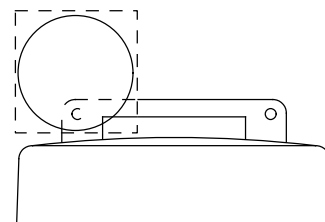

Warning reflector may be round or square. Must have a yellow reflective surface area of at least 30 square inches

Arrow Boards may be located behind channelizing devices in place for a shoulder taper or merging taper, otherwise they shall be delineated with four (4) channelizing devices placed perpendicular to traffic on the upstream side of traffic.

- The Flashing Arrow Board should be used for all lane closures on multi-lane roadways, or slow moving maintenance or construction activities on the travel lanes.
- Flashing Arrow Boards should not be used on two-lane, two-way roadways, detours, diversions or work on shoulders unless the "CAUTION" display (see detail below) is used.
- The Engineer/Inspector shall choose all appropriate signs, barricades and/or other traffic control devices that should be used in conjunction with the Flashing Arrow Board.
- The Flashing Arrow Board should be able to display the following symbols:

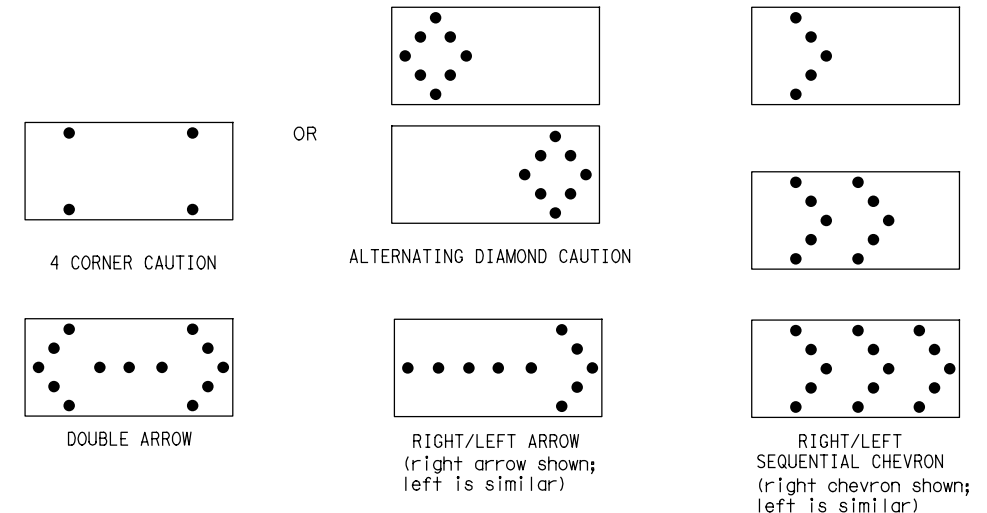

- The "CAUTION" display consists of four corner lamps flashing simultaneously, or the Alternating Diamond Caution mode as shown.
- The straight line caution display is NOT ALLOWED.
- The Flashing Arrow Board shall be capable of minimum 50 percent dimming from rated lamp voltage. The flashing rate of the lamps shall not be less than 25 nor more than 40 flashes per minute.
- Minimum lamp "on time" shall be approximately 50 percent for the flashing arrow and equal intervals of 25 percent for each sequential phase of the flashing chevron.
- The sequential arrow display is NOT ALLOWED.
- The flashing arrow display is the TxDOT standard; however, the sequential chevron display may be used during daylight operations.
- The Flashing Arrow Board shall be mounted on a vehicle, trailer or other suitable support.
- A Flashing Arrow Board SHALL NOT BE USED to laterally shift traffic.
- A full matrix PCMS may be used to simulate a Flashing Arrow Board provided it meets visibility, flash rate and dimming requirements on this sheet for the same size arrow.
- Minimum mounting height of trailer mounted Arrow Boards should be 7 feet from roadway to bottom of panel.

REQUIREMENTS			
TYPE	MINIMUM SIZE	MINIMUM NUMBER OF PANEL LAMPS	MINIMUM VISIBILITY DISTANCE
B	30 x 60	13	3/4 mile
C	48 x 96	15	1 mile

ATTENTION
Flashing Arrow Boards shall be equipped with automatic dimming devices.

WHEN NOT IN USE, REMOVE THE ARROW BOARD FROM THE RIGHT-OF-WAY OR PLACE THE ARROW BOARD BEHIND CONCRETE TRAFFIC BARRIER OR GUARDRAIL.

FLASHING ARROW BOARDS

SHEET 7 OF 12

TRUCK-MOUNTED ATTENUATORS

- Truck-mounted attenuators (TMA) used on TxDOT facilities must meet the requirements outlined in the Manual for Assessing Safety Hardware (MASH).
- Refer to the CWZTCD for the requirements of Level 2 or Level 3 TMAs.
- Refer to the CWZTCD for a list of approved TMAs.
- TMAs are required on freeways unless otherwise noted in the plans.
- A TMA should be used anytime that it can be positioned 30 to 100 feet in advance of the area of crew exposure without adversely affecting the work performance.
- The only reason a TMA should not be required is when a work area is spread down the roadway and the work crew is an extended distance from the TMA.



BARRICADE AND CONSTRUCTION ARROW PANEL, REFLECTORS, WARNING LIGHTS & ATTENUATOR

BC (7) -21

FILE:	bc-21.dgn	DN:	TxDOT	CK:	TxDOT	DW:	TxDOT	CK:	TxDOT
© TxDOT	November 2002	CONT	SECT	JOB	HIGHWAY				
REVISIONS		0910	16	180	SH 64, Etc.				
9-07	8-14	DIST	COUNTY		SHEET NO.				
7-13	5-21	TYL	SMITH, Etc.		12				

DATE: 5/16/2024 9:30:39 AM FILE: c:\pw-inf\fratex\in.zhang\dms47076\bc-21.dgn

DATE: 5/16/2024 9:30:39 AM
 FILE: c:\pw-InfraTech\In.Zhang\dms47076\bc-21.dgn

DISCLAIMER:
 The use of this standard is governed by the "Texas Engineering Practice Act". No warranty of any kind is made by TxDOT for any purpose whatsoever. TxDOT assumes no responsibility for the conversion of this standard to other formats or for incorrect results or damages resulting from its use.

GENERAL NOTES

- For long term stationary work zones on freeways, drums shall be used as the primary channelizing device.
- For intermediate term stationary work zones on freeways, drums should be used as the primary channelizing device but may be replaced in tangent sections by vertical panels, or 42" two-piece cones. In tangent sections, one-piece cones may be used with the approval of the Engineer but only if personnel are present on the project at all times to maintain the cones in proper position and location.
- For short term stationary work zones on freeways, drums are the preferred channelizing device but may be replaced in tapers, transitions and tangent sections by vertical panels, two-piece cones or one-piece cones as approved by the Engineer.
- Drums and all related items shall comply with the requirements of the current version of the "Texas Manual on Uniform Traffic Control Devices" (TMUTCD) and the "Compliant Work Zone Traffic Control Devices List" (CWZTCD).
- Drums, bases, and related materials shall exhibit good workmanship and shall be free from objectionable marks or defects that would adversely affect their appearance or serviceability.
- The Contractor shall have a maximum of 24 hours to replace any plastic drums identified for replacement by the Engineer/Inspector. The replacement device must be an approved device.

GENERAL DESIGN REQUIREMENTS

Pre-qualified plastic drums shall meet the following requirements:

- Plastic drums shall be a two-piece design; the "body" of the drum shall be the top portion and the "base" shall be the bottom.
- The body and base shall lock together in such a manner that the body separates from the base when impacted by a vehicle traveling at a speed of 20 MPH or greater but prevents accidental separation due to normal handling and/or air turbulence created by passing vehicles.
- Plastic drums shall be constructed of lightweight flexible, and deformable materials. The Contractor shall NOT use metal drums or single piece plastic drums as channelization devices or sign supports.
- Drums shall present a profile that is a minimum of 18 inches in width at the 36 inch height when viewed from any direction. The height of drum unit (body installed on base) shall be a minimum of 36 inches and a maximum of 42 inches.
- The top of the drum shall have a built-in handle for easy pickup and shall be designed to drain water and not collect debris. The handle shall have a minimum of two widely spaced 9/16 inch diameter holes to allow attachment of a warning light, warning reflector unit or approved compliant sign.
- The exterior of the drum body shall have a minimum of four alternating orange and white retroreflective circumferential stripes not less than 4 inches nor greater than 8 inches in width. Any non-reflectORIZED space between any two adjacent stripes shall not exceed 2 inches in width.
- Bases shall have a maximum width of 36 inches, a maximum height of 4 inches, and a minimum of two footholds of sufficient size to allow base to be held down while separating the drum body from the base.
- Plastic drums shall be constructed of ultra-violet stabilized, orange, high-density polyethylene (HDPE) or other approved material.
- Drum body shall have a maximum unballasted weight of 11 lbs.
- Drum and base shall be marked with manufacturer's name and model number.

RETROREFLECTIVE SHEETING

- The stripes used on drums shall be constructed of sheeting meeting the color and retroreflectivity requirements of Departmental Materials Specification DMS-8300, "Sign Face Materials." Type A or Type B reflective sheeting shall be supplied unless otherwise specified in the plans.
- The sheeting shall be suitable for use on and shall adhere to the drum surface such that, upon vehicular impact, the sheeting shall remain adhered in-place and exhibit no delaminating, cracking, or loss of retroreflectivity other than that loss due to abrasion of the sheeting surface.

BALLAST

- Unballasted bases shall be large enough to hold up to 50 lbs. of sand. This base, when filled with the ballast material, should weigh between 35 lbs (minimum) and 50 lbs (maximum). The ballast may be sand in one to three sandbags separate from the base, sand in a sand-filled plastic base, or other ballasting devices as approved by the Engineer. Stacking of sandbags will be allowed, however height of sandbags above pavement surface may not exceed 12 inches.
- Bases with built-in ballast shall weigh between 40 lbs. and 50 lbs. Built-in ballast can be constructed of an integral crumb rubber base or a solid rubber base.
- Recycled truck tire sidewalls may be used for ballast on drums approved for this type of ballast on the CWZTCD list.
- The ballast shall not be heavy objects, water, or any material that would become hazardous to motorists, pedestrians, or workers when the drum is struck by a vehicle.
- When used in regions susceptible to freezing, drums shall have drainage holes in the bottoms so that water will not collect and freeze becoming a hazard when struck by a vehicle.
- Ballast shall not be placed on top of drums.
- Adhesives may be used to secure base of drums to pavement.

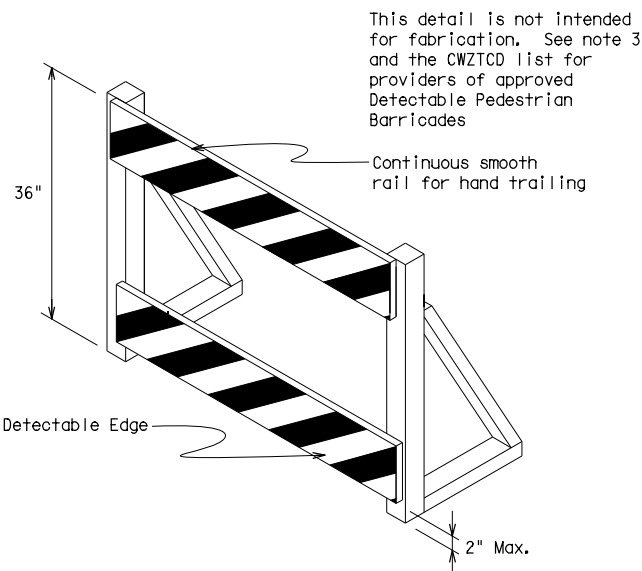
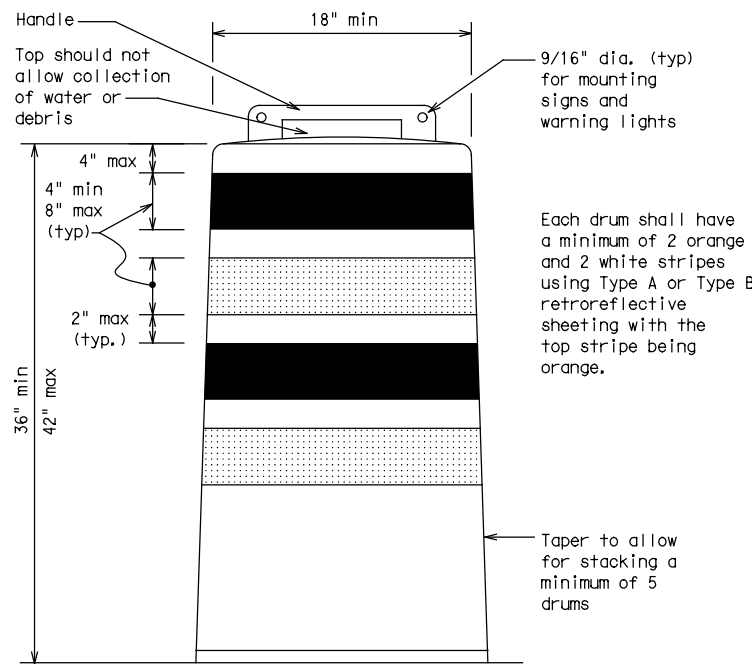

DETECTABLE PEDESTRIAN BARRICADES

- When existing pedestrian facilities are disrupted, closed, or relocated in a TTC zone, the temporary facilities shall be detectable and include accessibility features consistent with the features present in the existing pedestrian facility. Refer to WZ(BTS-2) for Pedestrian Control requirements for Sidewalk Diversions, Sidewalk Detours and Crosswalk Closures.
- Where pedestrians with visual disabilities normally use the closed sidewalk, a Detectable Pedestrian Barricade shall be placed across the full width of the closed sidewalk instead of a Type 3 Barricade.
- Detectable pedestrian barricades similar to the one pictured above, longitudinal channelizing devices, some concrete barriers, and wood or chain link fencing with a continuous detectable edging can satisfactorily delineate a pedestrian path.
- Tape, rope, or plastic chain strung between devices are not detectable, do not comply with the design standards in the "Americans with Disabilities Act Accessibility Guidelines (ADAAG)" and should not be used as a control for pedestrian movements.
- Warning lights shall not be attached to detectable pedestrian barricades.
- Detectable pedestrian barricades should use 8" nominal barricade rails as shown on BC(10) provided that the top rail provides a smooth continuous rail suitable for hand trailing with no splinters, burrs, or sharp edges.

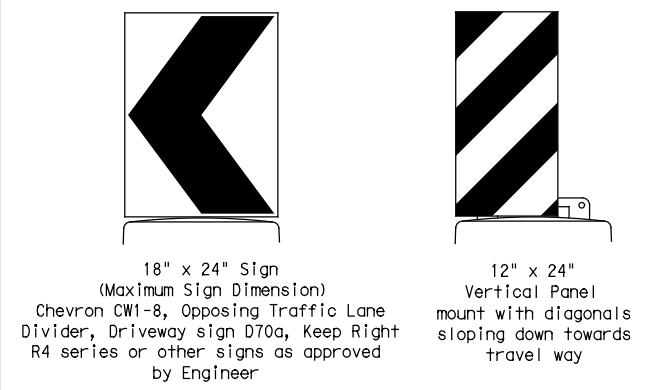

Plywood, Aluminum or Metal sign substrates shall NOT be used on plastic drums

SIGNS, CHEVRONS, AND VERTICAL PANELS MOUNTED ON PLASTIC DRUMS

- Signs used on plastic drums shall be manufactured using substrates listed on the CWZTCD.
- Chevrons and other work zone signs with an orange background shall be manufactured with Type B_{FL} or Type C_{FL} Orange sheeting meeting the color and retroreflectivity requirements of DMS-8300, "Sign Face Material," unless otherwise specified in the plans.
- Vertical Panels shall be manufactured with orange and white sheeting meeting the requirements of DMS-8300 Type A or Type B. Diagonal stripes on Vertical Panels shall slope down toward the intended traveled lane.
- Other sign messages (text or symbolic) may be used as approved by the Engineer. Sign dimensions shall not exceed 18 inches in width or 24 inches in height, except for the R9 series signs discussed in note 8 below.
- Signs shall be installed using a 1/2 inch bolt (nominal) and nut, two washers, and one locking washer for each connection.
- Mounting bolts and nuts shall be fully engaged and adequately torqued. Bolts should not extend more than 1/2 inch beyond nuts.
- Chevrons may be placed on drums on the outside of curves, on merging tapers or on shifting tapers. When used in these locations, they may be placed on every drum or spaced not more than on every third drum. A minimum of three (3) should be used at each location called for in the plans.
- R9-9, R9-10, R9-11 and R9-11a Sidewalk Closed signs which are 24 inches wide may be mounted on plastic drums, with approval of the Engineer.

SHEET 8 OF 12



BARRICADE AND CONSTRUCTION CHANNELIZING DEVICES

BC(8)-21

FILE:	bc-21.dgn	DN:	TxDOT	CK:	TxDOT	DW:	TxDOT	CK:	TxDOT
© TxDOT	November 2002	CONT	SECT	JOB	HIGHWAY				
REVISIONS		0910	16	180	SH 64, Etc.				
4-03	8-14	DIST	COUNTY	SHEET NO.					
9-07	5-21	TYL	SMITH, Etc.	13					
7-13									

DATE: 5/16/2024 9:30:39 AM
 FILE: c:\pw-InfraTech\Lin.Zhang\dms47076\bc-21.dgn

DISCLAIMER: The use of this standard is governed by the "Texas Engineering Practice Act". No warranty of any kind is made by TxDOT for any purpose whatsoever. TxDOT assumes no responsibility for the conversion of this standard to other formats or for incorrect results or damages resulting from its use.

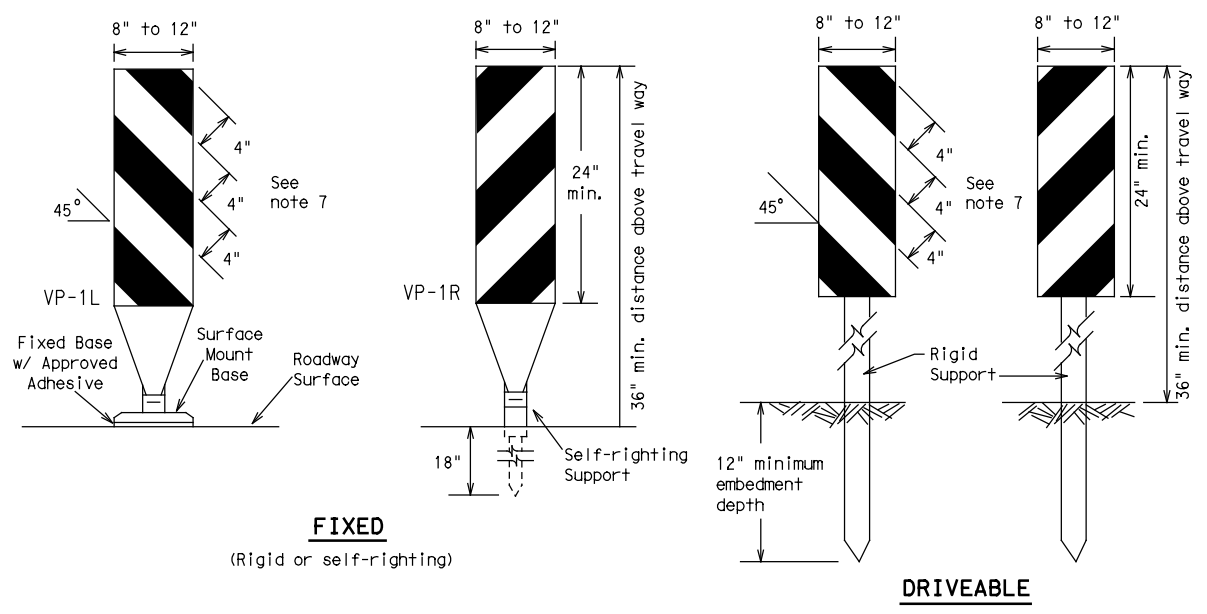

FIXED
(Rigid or self-righting)

DRIVEABLE

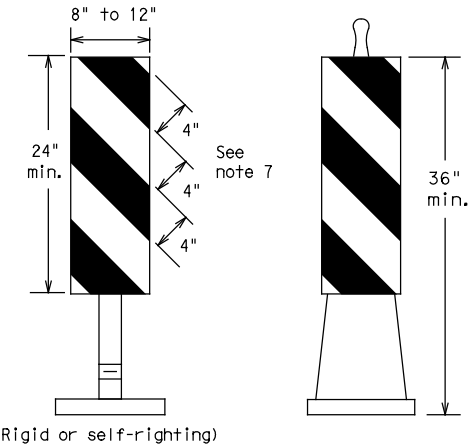

PORTABLE

VERTICAL PANELS (VPs)

- Vertical Panels (VP's) are normally used to channelize traffic or divide opposing lanes of traffic.
- VP's may be used in daytime or nighttime situations. They may be used at the edge of shoulder drop-offs and other areas such as lane transitions where positive daytime and nighttime delineation is required. The Engineer/Inspector shall refer to the Roadway Design Manual for additional requirements on the use VP's for drop-offs.
- VP's should be mounted back to back if used at the edge of cuts adjacent to two-way two lane roadways. Stripes are to be reflective orange and reflective white and should always slope downward toward the travel lane.
- VP's used on expressways and freeways or other high speed roadways, may have more than 270 square inches of retroreflective area facing traffic.
- Self-righting supports are available with portable base. See "Compliant Work Zone Traffic Control Devices List" (CWZTCD).
- Sheeting for the VP's shall be retroreflective Type A or Type B conforming to Departmental Material Specification DMS-8300, unless noted otherwise.
- Where the height of reflective material on the vertical panel is 36 inches or greater, a panel stripe of 6 inches shall be used.

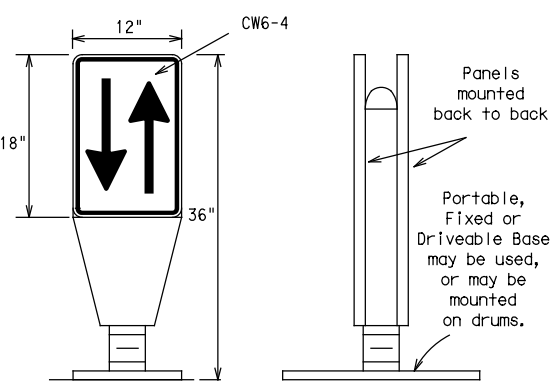

OPPOSING TRAFFIC LANE DIVIDERS (OTLD)

- Opposing Traffic Lane Dividers (OTLD) are delineation devices designed to convert a normal one-way roadway section to two-way operation. OTLD's are used on temporary centerlines. The upward and downward arrows on the sign's face indicate the direction of traffic on either side of the divider. The base is secured to the pavement with an adhesive or rubber weight to minimize movement caused by a vehicle impact or wind gust.
- The OTLD may be used in combination with 42" cones or VPs.
- Spacing between the OTLD shall not exceed 500 feet. 42" cones or VPs placed between the OTLD's should not exceed 100 foot spacing.
- The OTLD shall be orange with a black non-reflective legend. Sheeting for the OTLD shall be retroreflective Type B_{FL} or Type C_{FL} conforming to Departmental Material Specification DMS-8300, unless noted otherwise. The legend shall meet the requirements of DMS-8300.

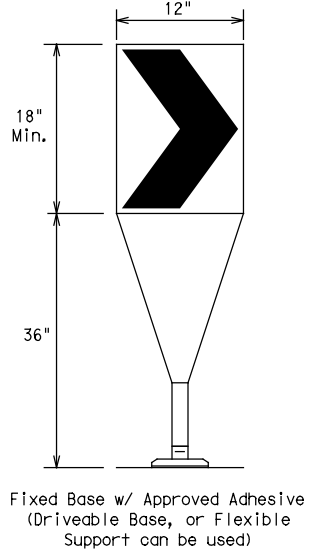

- The chevron shall be a vertical rectangle with a minimum size of 12 by 18 inches.
- Chevrons are intended to give notice of a sharp change of alignment with the direction of travel and provide additional emphasis and guidance for vehicle operators with regard to changes in horizontal alignment of the roadway.
- Chevrons, when used, shall be erected on the outside of a sharp curve or turn, or on the far side of an intersection. They shall be in line with and at right angles to approaching traffic. Spacing should be such that the motorist always has three in view, until the change in alignment eliminates its need.
- To be effective, the chevron should be visible for at least 500 feet.
- Chevrons shall be orange with a black nonreflective legend. Sheeting for the chevron shall be retroreflective Type B_{FL} or Type C_{FL} conforming to Departmental Material Specification DMS-8300, unless noted otherwise. The legend shall meet the requirements of DMS-8300.
- For Long Term Stationary use on tapers or transitions on freeways and divided highways, self-righting chevrons may be used to supplement plastic drums but not to replace plastic drums.

CHEVRONS

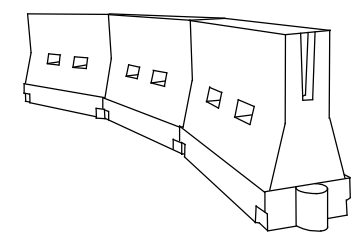

LONGITUDINAL CHANNELIZING DEVICES (LCD)

- LCDs are crashworthy, lightweight, deformable devices that are highly visible, have good target value and can be connected together. They are not designed to contain or redirect a vehicle on impact.
- LCDs may be used instead of a line of cones or drums.
- LCDs shall be placed in accordance to application and installation requirements specific to the device, and used only when shown on the CWZTCD list.
- LCDs should not be used to provide positive protection for obstacles, pedestrians or workers.
- LCDs shall be supplemented with retroreflective delineation as required for temporary barriers on BC(7) when placed roughly parallel to the travel lanes.
- LCDs used as barricades placed perpendicular to traffic should have at least one row of reflective sheeting meeting the requirements for barricade rails as shown on BC(10). Place reflective sheeting near the top of the LCD along the full length of the device.

WATER BALLASTED SYSTEMS USED AS BARRIERS

- Water ballasted systems used as barriers shall not be used solely to channelize road users, but also to protect the work space per the appropriate Manual for Assessing Safety Hardware (MASH) crashworthiness requirements based on roadway speed and barrier application.
- Water ballasted systems used to channelize vehicular traffic shall be supplemented with retroreflective delineation or channelizing devices to improve daytime/nighttime visibility. They may also be supplemented with pavement markings.
- Water ballasted systems used as barriers shall be placed in accordance to application and installation requirements specific to the device, and used only when shown on the CWZTCD list.
- Water ballasted systems used as barriers should not be used for a merging taper except in low speed (less than 45 MPH) urban areas. When used on a taper in a low speed urban area, the taper shall be delineated and the taper length should be designed to optimize road user operations considering the available geometric conditions.
- When water ballasted systems used as barriers have blunt ends exposed to traffic, they should be attenuated as per manufacturer recommendations or flared to a point outside the clear zone.

If used to channelize pedestrians, longitudinal channelizing devices or water ballasted systems must have a continuous detectable bottom for users of long canes and the top of the unit shall not be less than 32 inches in height.

HOLLOW OR WATER BALLASTED SYSTEMS USED AS LONGITUDINAL CHANNELIZING DEVICES OR BARRIERS

GENERAL NOTES

- Work Zone channelizing devices illustrated on this sheet may be installed in close proximity to traffic and are suitable for use on high or low speed roadways. The Engineer/Inspector shall ensure that spacing and placement is uniform and in accordance with the "Texas Manual on Uniform Traffic Control Devices" (TMUTCD).
- Channelizing devices shown on this sheet may have a driveable, fixed or portable base. The requirement for self-righting channelizing devices must be specified in the General Notes or other plan sheets.
- Channelizing devices on self-righting supports should be used in work zone areas where channelizing devices are frequently impacted by errant vehicles or vehicle related wind gusts making alignment of the channelizing devices difficult to maintain. Locations of these devices shall be detailed elsewhere in the plans. These devices shall conform to the TMUTCD and the "Compliant Work Zone Traffic Control Devices List" (CWZTCD).
- The Contractor shall maintain devices in a clean condition and replace damaged, nonreflective, faded, or broken devices and bases as required by the Engineer/Inspector. The Contractor shall be required to maintain proper device spacing and alignment.
- Portable bases shall be fabricated from virgin and/or recycled rubber. The portable bases shall weigh a minimum of 30 lbs.
- Pavement surfaces shall be prepared in a manner that ensures proper bonding between the adhesives, the fixed mount bases and the pavement surface. Adhesives shall be prepared and applied according to the manufacturer's recommendations.
- The installation and removal of channelizing devices shall not cause detrimental effects to the final pavement surfaces, including pavement surface discoloration or surface integrity. Driveable bases shall not be permitted on final pavement surfaces. The Engineer/Inspector shall approve all application and removal procedures of fixed bases.

Posted Speed	Formula	Minimum Desirable Taper Lengths *X			Suggested Maximum Spacing of Channelizing Devices	
		10' Offset	11' Offset	12' Offset	On a Taper	On a Tangent
30	L = WS ² / 60	150'	165'	180'	30'	60'
35		205'	225'	245'	35'	70'
40		265'	295'	320'	40'	80'
45	L = WS	450'	495'	540'	45'	90'
50		500'	550'	600'	50'	100'
55		550'	605'	660'	55'	110'
60		600'	660'	720'	60'	120'
65		650'	715'	780'	65'	130'
70		700'	770'	840'	70'	140'
75		750'	825'	900'	75'	150'
80		800'	880'	960'	80'	160'

*X*Taper lengths have been rounded off.
 L=Length of Taper (FT.) W=Width of Offset (FT.)
 S=Posted Speed (MPH)

SUGGESTED MAXIMUM SPACING OF CHANNELIZING DEVICES AND MINIMUM DESIRABLE TAPER LENGTHS

SHEET 9 OF 12



BARRICADE AND CONSTRUCTION CHANNELIZING DEVICES

BC (9) -21

FILE: bc-21.dgn	DN: TxDOT	CK: TxDOT	DW: TxDOT	CK: TxDOT
© TxDOT November 2002	CONT	SECT	JOB	HIGHWAY
REVISIONS	091016	180	SH 64, Etc.	
9-07 8-14	DIST	COUNTY	SHEET NO.	
7-13 5-21	TYL	SMITH, Etc.	14	

DISCLAIMER: The use of this standard is governed by the "Texas Engineering Practice Act". No warranty of any kind is made by TxDOT for any purpose whatsoever. TxDOT assumes no responsibility for the conversion of this standard to other formats or for incorrect results or damages resulting from its use.

TYPE 3 BARRICADES

1. Refer to the Compliant Work Zone Traffic Control Devices List (CWZTCD) for details of the Type 3 Barricades and a list of all materials used in the construction of Type 3 Barricades.
2. Type 3 Barricades shall be used at each end of construction projects closed to all traffic.
3. Barricades extending across a roadway should have stripes that slope downward in the direction toward which traffic must turn in detouring. When both right and left turns are provided, the chevron striping may slope downward in both directions from the center of the barricade. Where no turns are provided at a closed road, striping should slope downward in both directions toward the center of roadway.
4. Striping of rails, for the right side of the roadway, should slope downward to the left. For the left side of the roadway, striping should slope downward to the right.
5. Identification markings may be shown only on the back of the barricade rails. The maximum height of letters and/or company logos used for identification shall be 1".
6. Barricades shall not be placed parallel to traffic unless an adequate clear zone is provided.
7. Warning lights shall NOT be installed on barricades.
8. Where barricades require the use of weights to keep from turning over, the use of sandbags with dry, cohesionless sand is recommended. The sandbags will be tied shut to keep the sand from spilling and to maintain a constant weight. Sand bags shall not be stacked in a manner that covers any portion of a barricade rails reflective sheeting. Rock, concrete, iron, steel or other solid objects will NOT be permitted. Sandbags should weigh a minimum of 35 lbs and a maximum of 50 lbs. Sandbags shall be made of a durable material that tears upon vehicular impact. Rubber (such as tire inner tubes) shall not be used for sandbags. Sandbags shall only be placed along or upon the base supports of the device and shall not be suspended above ground level or hung with rope, wire, chains or other fasteners.
9. Sheeting for barricades shall be retroreflective Type A or Type B conforming to Departmental Material Specification DMS-8300 unless otherwise noted.

Barricades shall NOT be used as a sign support.

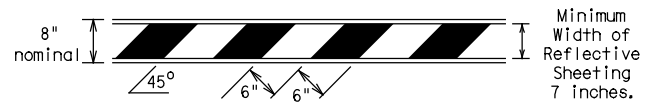

TYPICAL STRIPING DETAIL FOR BARRICADE RAIL

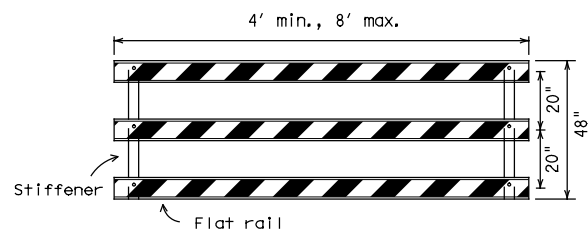

TYPICAL PANEL DETAIL FOR SKID OR POST TYPE BARRICADES

Each roadway of a divided highway shall be barricaded in the same manner.

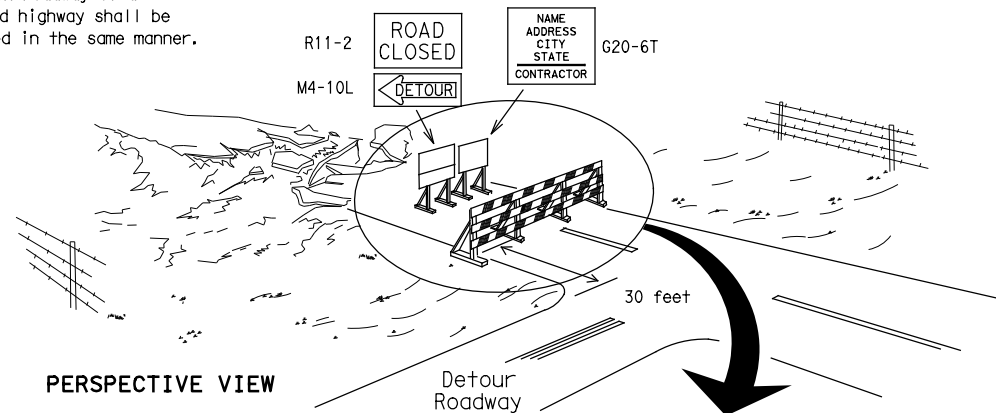

PERSPECTIVE VIEW

The three rails on Type 3 barricades shall be reflectorized orange and reflective white stripes on one side facing one-way traffic and both sides for two-way traffic. Barricade striping should slant downward in the direction of detour.

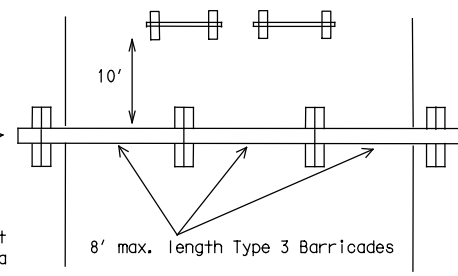

PLAN VIEW

1. Signs should be mounted on independent supports at a 7 foot mounting height in center of roadway. The signs should be a minimum of 10 feet behind Type 3 Barricades.
2. Advance signing shall be as specified elsewhere in the plans.

TYPE 3 BARRICADE (POST AND SKID) TYPICAL APPLICATION

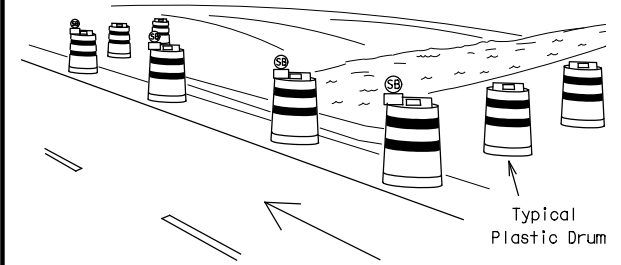

PERSPECTIVE VIEW

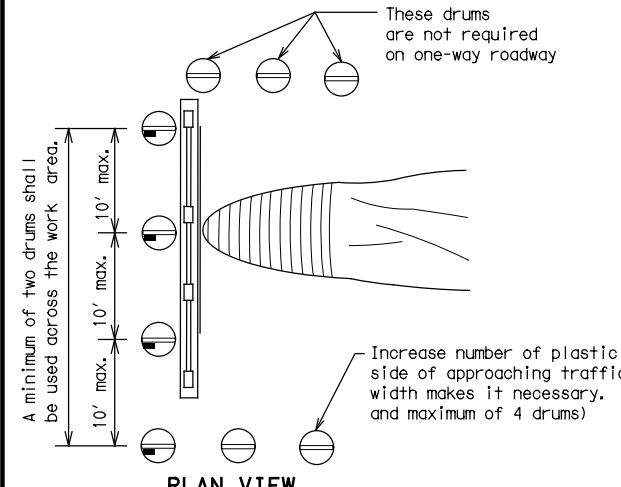

PLAN VIEW

CULVERT WIDENING OR OTHER ISOLATED WORK WITHIN THE PROJECT LIMITS

1. Where positive redirection capability is provided, drums may be omitted.
2. Plastic construction fencing may be used with drums for safety as required in the plans.
3. Vertical Panels on flexible support may be substituted for drums when the shoulder width is less than 4 feet.
4. When the shoulder width is greater than 12 feet, steady-burn lights may be omitted if drums are used.
5. Drums must extend the length of the culvert widening.

LEGEND	
	Plastic drum
	Plastic drum with steady burn light or yellow warning reflector
	Steady burn warning light or yellow warning reflector

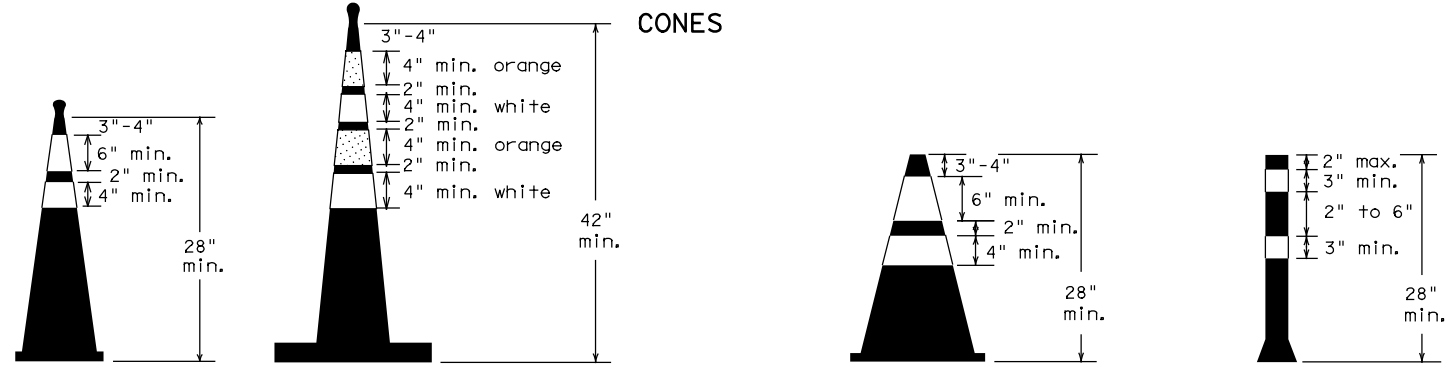

Two-Piece cones

One-Piece cones

Tubular Marker

28" Cones shall have a minimum weight of 9 1/2 lbs.
 42" 2-piece cones shall have a minimum weight of 30 lbs. including base.

1. Traffic cones and tubular markers shall be predominantly orange, and meet the height and weight requirements shown above.
2. One-piece cones have the body and base of the cone molded in one consolidated unit. Two-piece cones have a cone shaped body and a separate rubber base, or ballast, that is added to keep the device upright and in place.
3. Two-piece cones may have a handle or loop extending up to 8" above the minimum height shown, in order to aid in retrieving the device.
4. Cones or tubular markers shall have white or white and orange reflective bands as shown above. The reflective bands shall have a smooth, sealed outer surface and meet the requirements of Departmental Material Specification DMS-8300 Type A or Type B.
5. 28" cones and tubular markers are generally suitable for short duration and short-term stationary work as defined on BC(4). These should not be used for intermediate-term or long-term stationary work unless personnel is on-site to maintain them in their proper upright position.
6. 42" two-piece cones, vertical panels or drums are suitable for all work zone durations.
7. Cones or tubular markers used on each project should be of the same size and shape.

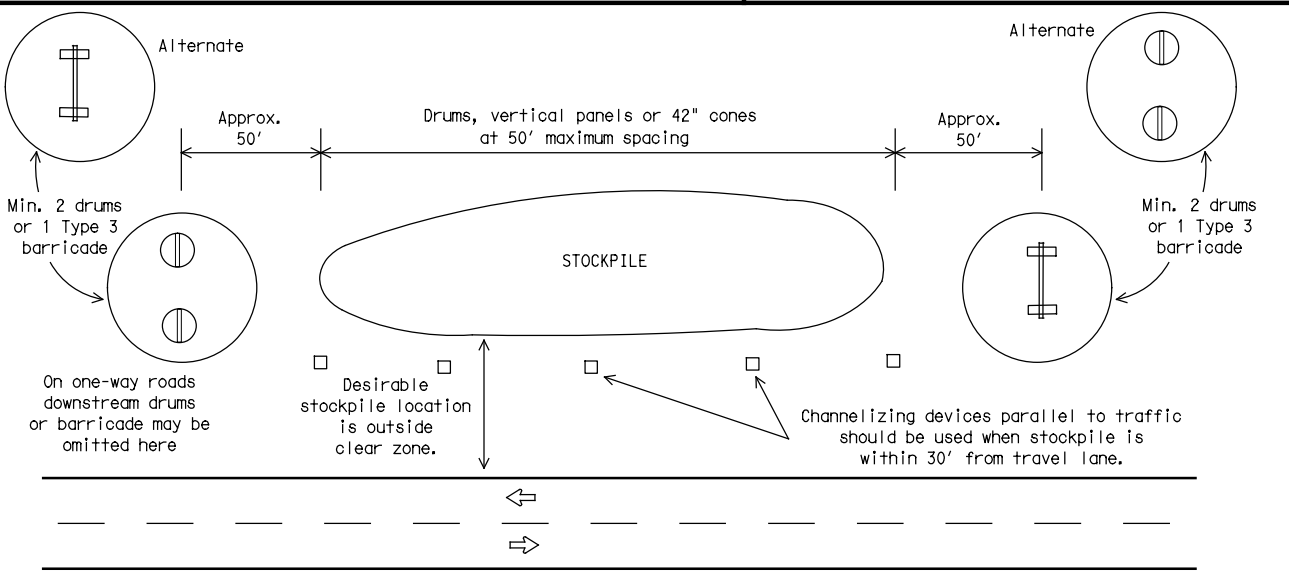

TRAFFIC CONTROL FOR MATERIAL STOCKPILES



BARRICADE AND CONSTRUCTION CHANNELIZING DEVICES

BC(10)-21

FILE: bc-21.dgn	DN: TxDOT	CK: TxDOT	DW: TxDOT	CK: TxDOT
©TxDOT November 2002	CONT	SECT	JOB	HIGHWAY
REVISIONS	0910	16	180	SH 64, Etc.
9-07 8-14	DIST	COUNTY	SHEET NO.	
7-13 5-21	TYL	SMITH, Etc.	15	

DATE: 5/16/2024 9:30:39 AM
 FILE: c:\pw-inf\fratex\in.zhang\dms47076\bc-21.dgn

DISCLAIMER: The use of this standard is governed by the "Texas Engineering Practice Act". No warranty of any kind is made by TxDOT for any purpose whatsoever. TxDOT assumes no responsibility for the conversion of this standard to other formats or for incorrect results or damages resulting from its use.

DATE: 5/16/2024 9:30:43 AM
 FILE: c:\pw-InfRatech\in.zhang\dms47076\top1-1-18.dgn

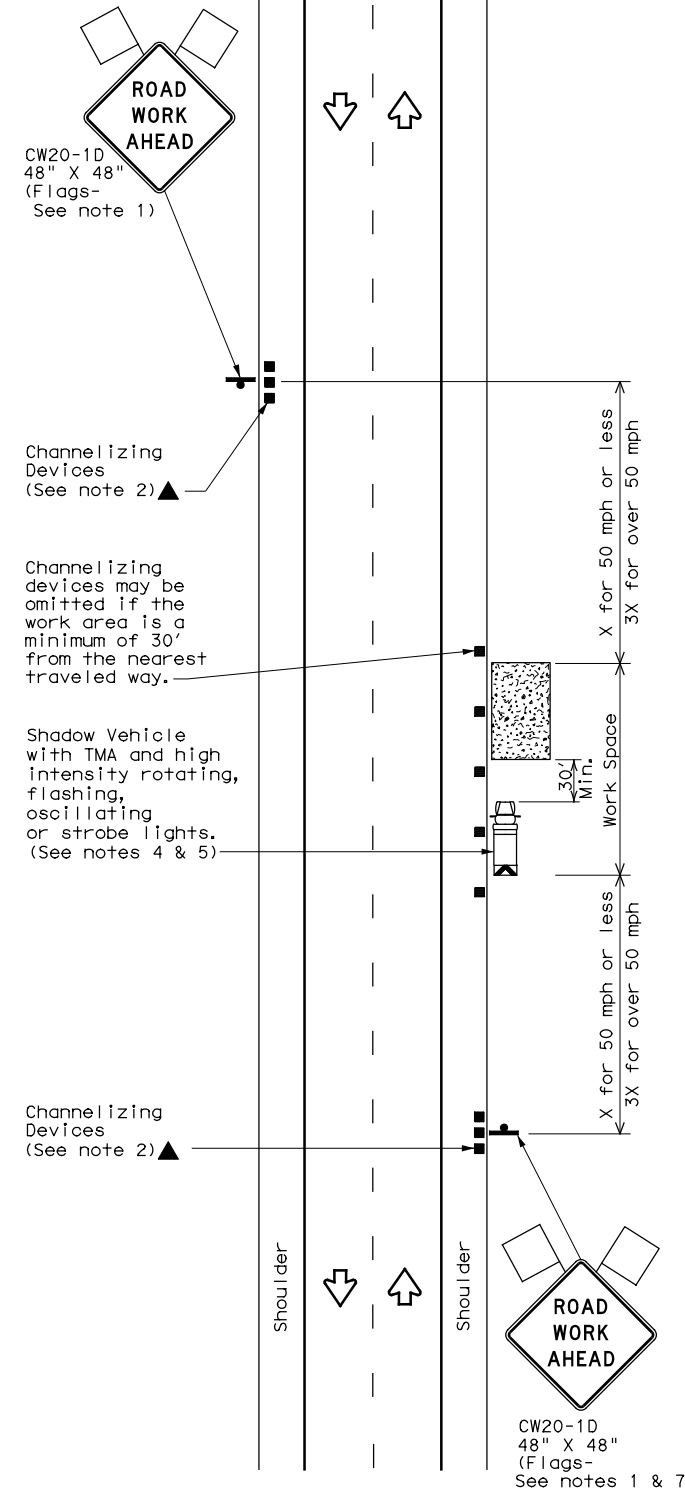

TCP (1-1a)

WORK SPACE NEAR SHOULDER
 Conventional Roads

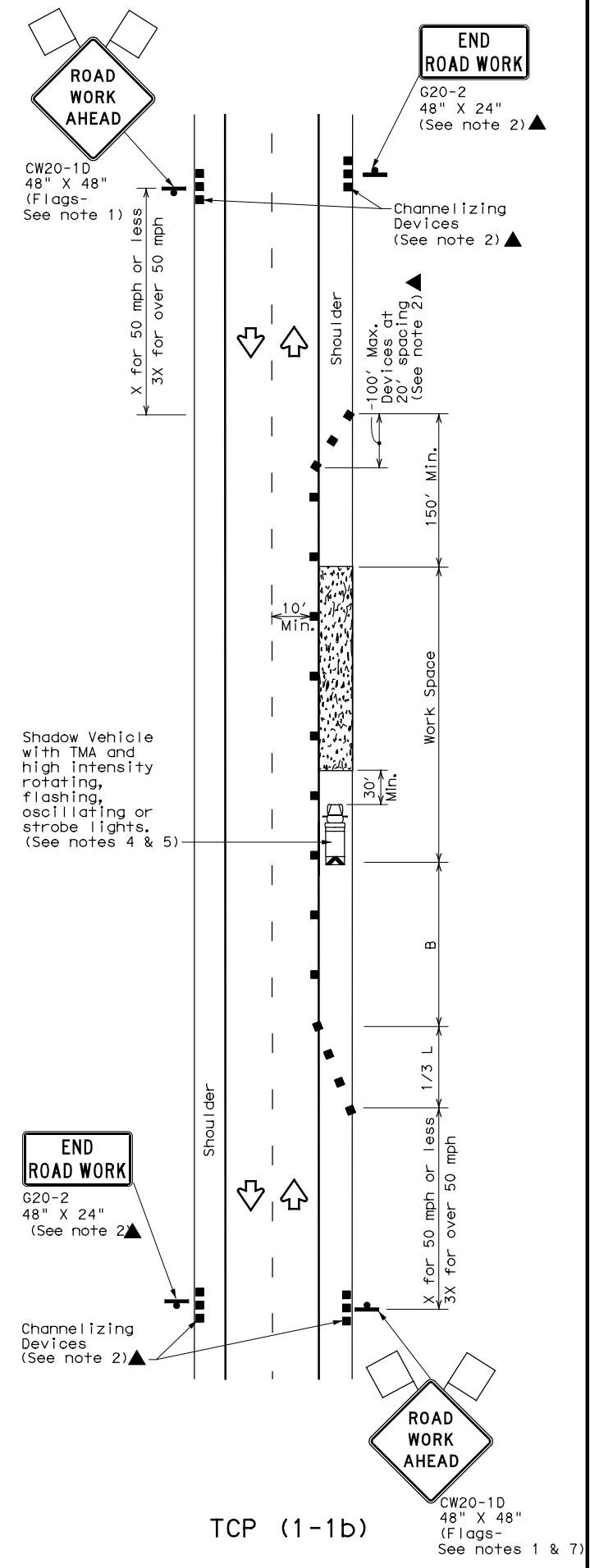

TCP (1-1b)

WORK SPACE ON SHOULDER
 Conventional Roads

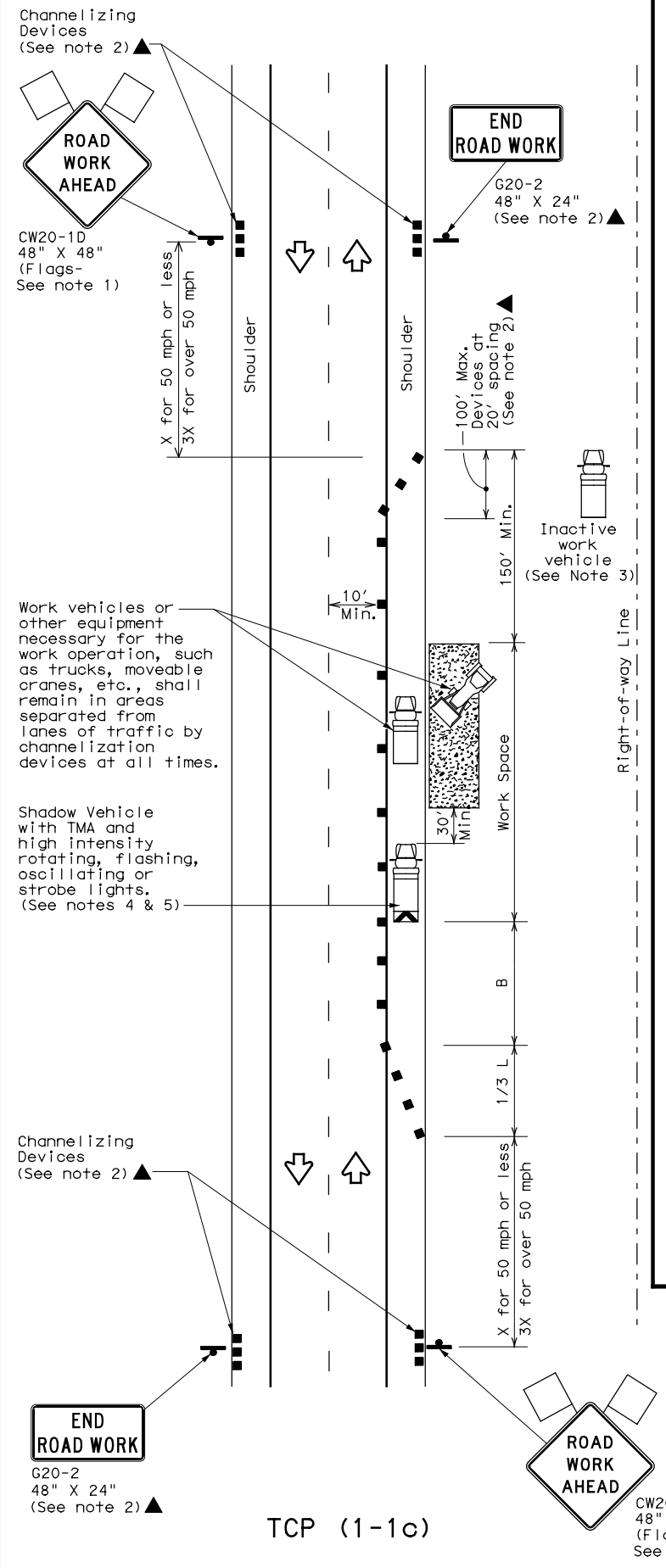

TCP (1-1c)

WORK VEHICLES ON SHOULDER
 Conventional Roads

LEGEND			
	Type 3 Barricade		Channelizing Devices
	Heavy Work Vehicle		Truck Mounted Attenuator (TMA)
	Trailer Mounted Flashing Arrow Board		Portable Changeable Message Sign (PCMS)
	Sign		Traffic Flow
	Flag		Flagger

Posted Speed *	Formula	Minimum Desirable Taper Lengths **			Suggested Maximum Spacing of Channelizing Devices		Minimum Sign Spacing "X" Distance	Suggested Longitudinal Buffer Space "B"
		10' Offset	11' Offset	12' Offset	On a Taper	On a Tangent		
30	$L = \frac{WS^2}{60}$	150'	165'	180'	30'	60'	120'	90'
35		205'	225'	245'	35'	70'	160'	120'
40		265'	295'	320'	40'	80'	240'	155'
45	L = WS	450'	495'	540'	45'	90'	320'	195'
50		500'	550'	600'	50'	100'	400'	240'
55		550'	605'	660'	55'	110'	500'	295'
60		600'	660'	720'	60'	120'	600'	350'
65		650'	715'	780'	65'	130'	700'	410'
70		700'	770'	840'	70'	140'	800'	475'
75		750'	825'	900'	75'	150'	900'	540'

* Conventional Roads Only
 ** Taper lengths have been rounded off.
 L=Length of Taper (FT) W=Width of Offset (FT) S=Posted Speed (MPH)

TYPICAL USAGE				
MOBILE	SHORT DURATION	SHORT TERM STATIONARY	INTERMEDIATE TERM STATIONARY	LONG TERM STATIONARY
	✓	✓		

- GENERAL NOTES**
- Flags attached to signs where shown are REQUIRED.
 - All traffic control devices illustrated are REQUIRED, except those denoted with the triangle symbol may be omitted when stated elsewhere in the plans, or for routine maintenance work, when approved by the Engineer.
 - Inactive work vehicles or other equipment should be parked near the right-of-way line and not parked on the paved shoulder.
 - A Shadow Vehicle with a TMA should be used anytime it can be positioned 30 to 100 feet in advance of the area of crew exposure without adversely affecting the performance or quality of the work. If workers are no longer present but road or work conditions require the traffic control to remain in place, Type 3 Barricades or other channelizing devices may be substituted for the Shadow Vehicle and TMA.
 - Additional Shadow Vehicles with TMAs may be positioned off the paved surface, next to those shown in order to protect wider work spaces.
 - See TCP(5-1) for shoulder work on divided highways, expressways and freeways.
 - CW21-5 "SHOULDER WORK" signs may be used in place of CW20-1D "ROAD WORK AHEAD" signs for shoulder work on conventional roadways.



TRAFFIC CONTROL PLAN
CONVENTIONAL ROAD
SHOULDER WORK

TCP (1-1) - 18

FILE: tcp1-1-18.dgn	DN:	CK:	DW:	CK:
© TxDOT December 1985	CON:	SECT:	JOB:	HIGHWAY:
REVISIONS	0910	16	180	SH 64, Etc.
2-94 4-98	DIST:	COUNTY:	SHEET NO.:	
8-95 2-12	TYL	SMITH, Etc.	16	
1-97 2-18				

DISCLAIMER: The use of this standard is governed by the "Texas Engineering Practice Act". No warranty of any kind is made by TxDOT for any purpose whatsoever. TxDOT assumes no responsibility for the conversion of this standard to other formats or for incorrect results or damages resulting from its use.

DATE: 5/16/2024 9:30:48 AM
 FILE: c:\pw-InfraTech\In.Zhang\dms47076\tcp1-2-18.dgn

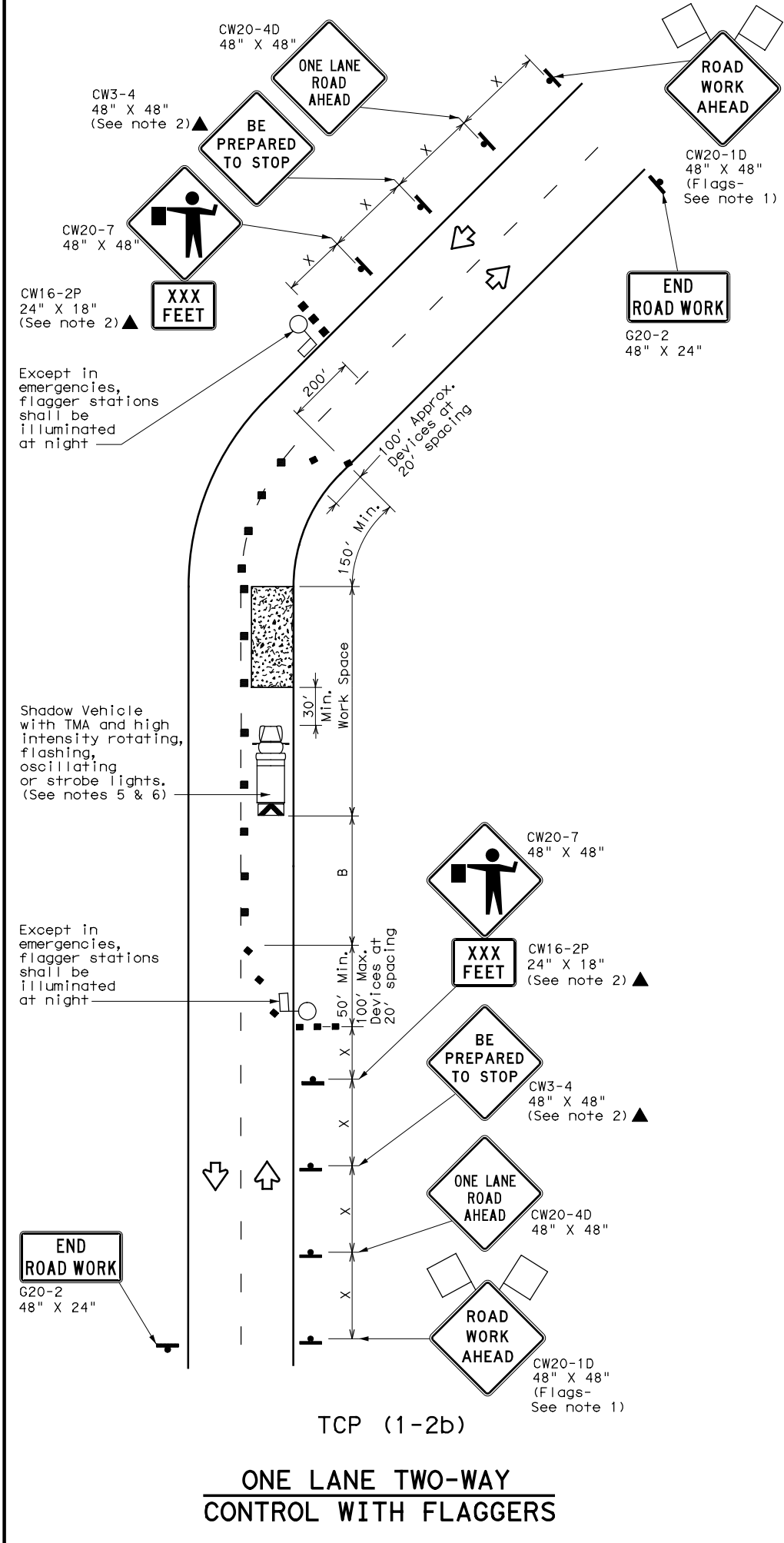
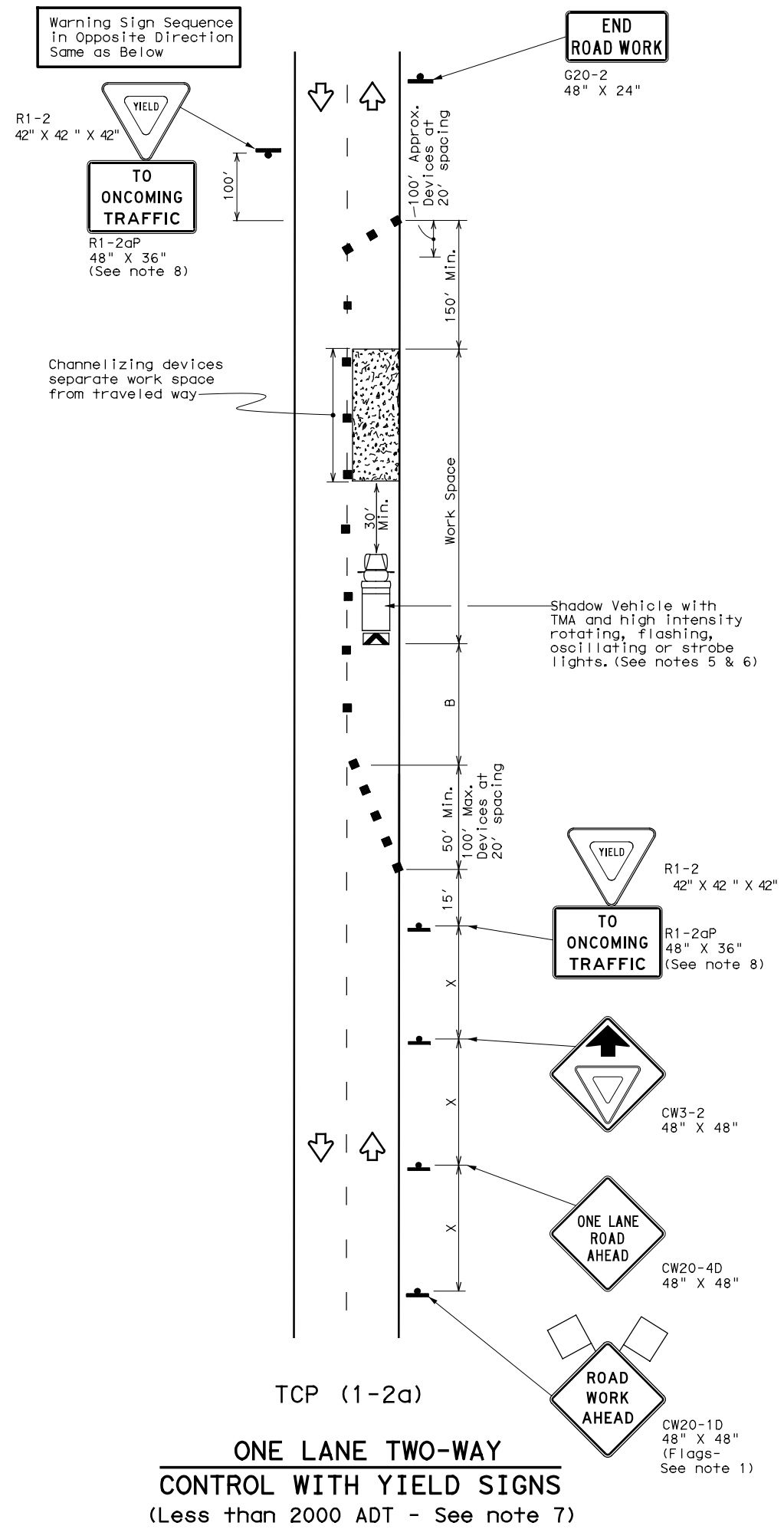

LEGEND			
	Type 3 Barricade		Channelizing Devices
	Heavy Work Vehicle		Truck Mounted Attenuator (TMA)
	Trailer Mounted Flashing Arrow Board		Portable Changeable Message Sign (PCMS)
	Sign		Traffic Flow
	Flag		Flagger

Posted Speed * X	Formula L = WS ² / 60	Minimum Desirable Taper Lengths **			Suggested Maximum Spacing of Channelizing Devices		Minimum Sign Spacing "X" Distance	Suggested Longitudinal Buffer Space "B"	Stopping Sight Distance
		10' Offset	11' Offset	12' Offset	On a Taper	On a Tangent			
30	L = WS ² / 60	150'	165'	180'	30'	60'	120'	90'	200'
35		205'	225'	245'	35'	70'	160'	120'	250'
40		265'	295'	320'	40'	80'	240'	155'	305'
45		450'	495'	540'	45'	90'	320'	195'	360'
50	L = WS	500'	550'	600'	50'	100'	400'	240'	425'
55		550'	605'	660'	55'	110'	500'	295'	495'
60		600'	660'	720'	60'	120'	600'	350'	570'
65		650'	715'	780'	65'	130'	700'	410'	645'
70		700'	770'	840'	70'	140'	800'	475'	730'
75		750'	825'	900'	75'	150'	900'	540'	820'

* Conventional Roads Only
 ** Taper lengths have been rounded off.
 L=Length of Taper (FT) W=Width of Offset (FT) S=Posted Speed (MPH)

TYPICAL USAGE				
MOBILE	SHORT DURATION	SHORT TERM STATIONARY	INTERMEDIATE TERM STATIONARY	LONG TERM STATIONARY
	✓	✓		

GENERAL NOTES

- Flags attached to signs where shown are REQUIRED.
- All traffic control devices illustrated are REQUIRED, except those denoted with the triangle symbol may be omitted when stated elsewhere in the plans, or for routine maintenance work, when approved by the Engineer.
- The CW3-4 "BE PREPARED TO STOP" sign may be installed after the CW20-4D "ONE LANE ROAD AHEAD" sign, but proper sign spacing shall be maintained.
- Sign spacing may be increased or an additional CW20-1D "ROAD WORK AHEAD" sign may be used if advance warning ahead of the flagger or R1-2 "YIELD" sign is less than 1500 feet.
- A Shadow Vehicle with a TMA should be used anytime it can be positioned 30 to 100 feet in advance of the area of crew exposure without adversely affecting the performance or quality of the work. If workers are no longer present but road or work conditions require the traffic control to remain in place, Type 3 Barricades or other channelizing devices may be substituted for the Shadow Vehicle and TMA.
- Additional Shadow Vehicles with TMAs may be positioned off the paved surface, next to those shown in order to protect wider work spaces.

TCP (1-2a)

- R1-2 "YIELD" sign traffic control may be used on projects with approaches that have adequate sight distance. For projects in urban areas, work spaces should be no longer than one half city block. In rural areas on roadways with less than 2000 ADT, work spaces should be no longer than 400 feet.
- R1-2 "YIELD" sign with R1-2aP "TO ONCOMING TRAFFIC" plaque shall be placed on a support at a 7 foot minimum mounting height.

TCP (1-2b)

- Flaggers should use two-way radios or other methods of communication to control traffic.
- Length of work space should be based on the ability of flaggers to communicate.
- If the work space is located near a horizontal or vertical curve, the buffer distances should be increased in order to maintain adequate stopping sight distance to the flagger and a queue of stopped vehicles (see table above).
- Channelizing devices on the center-line may be omitted when a pilot car is leading traffic and approved by the Engineer.
- Flaggers should use 24" STOP/SLOW paddles to control traffic. Flags should be limited to emergency situations.

		Traffic Operations Division Standard	
TRAFFIC CONTROL PLAN			
ONE-LANE TWO-WAY			
TRAFFIC CONTROL			
TCP (1-2) - 18			
FILE: tcp1-2-18.dgn	DN:	CK:	DW: CK:
© TxDOT December 1985	CON: 0910	SECT: 16	JOB: 180 SH 64, Etc.
REVISIONS	DIST: COUNTY		SHEET NO.
4-90 4-98	TYL SMITH, Etc.		17
2-94 2-12			
1-97 2-18			

DISCLAIMER: The use of this standard is governed by the "Texas Engineering Practice Act". No warranty of any kind is made by TxDOT for any purpose whatsoever. TxDOT assumes no responsibility for the conversion of this standard to other formats or for incorrect results or damages resulting from its use.

DATE: 5/16/2024 9:30:52 AM
 FILE: c:\pw-InfraTech\in.zhang\dms47076.wzrs22.dgn

Warning sign and rumble strip sequence in opposite direction is same as below.

TABLE 1		
Flagger to Flagger (Length of Work Area)	ADT	# of Rumble Strip Arrays
1/8 Mile	< 4,500	1
	≥ 4,500	2
1/4 Mile	< 3,500	1
	≥ 3,500	2
1/2 Mile	< 2,600	1
	≥ 2,600	2
1 Mile	< 1,600	1
	≥ 1,600	2
> 1 Mile	N/A	2

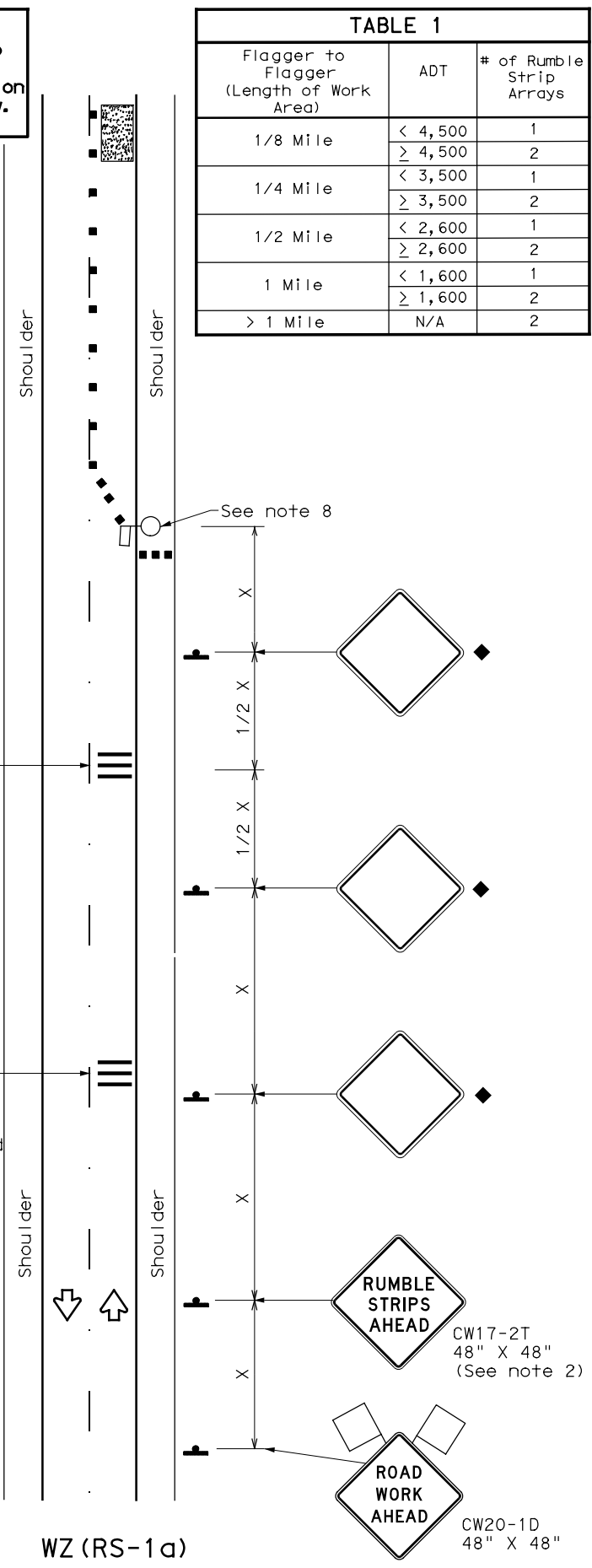

RUMBLE STRIPS ON ONE-LANE TWO-WAY APPLICATION

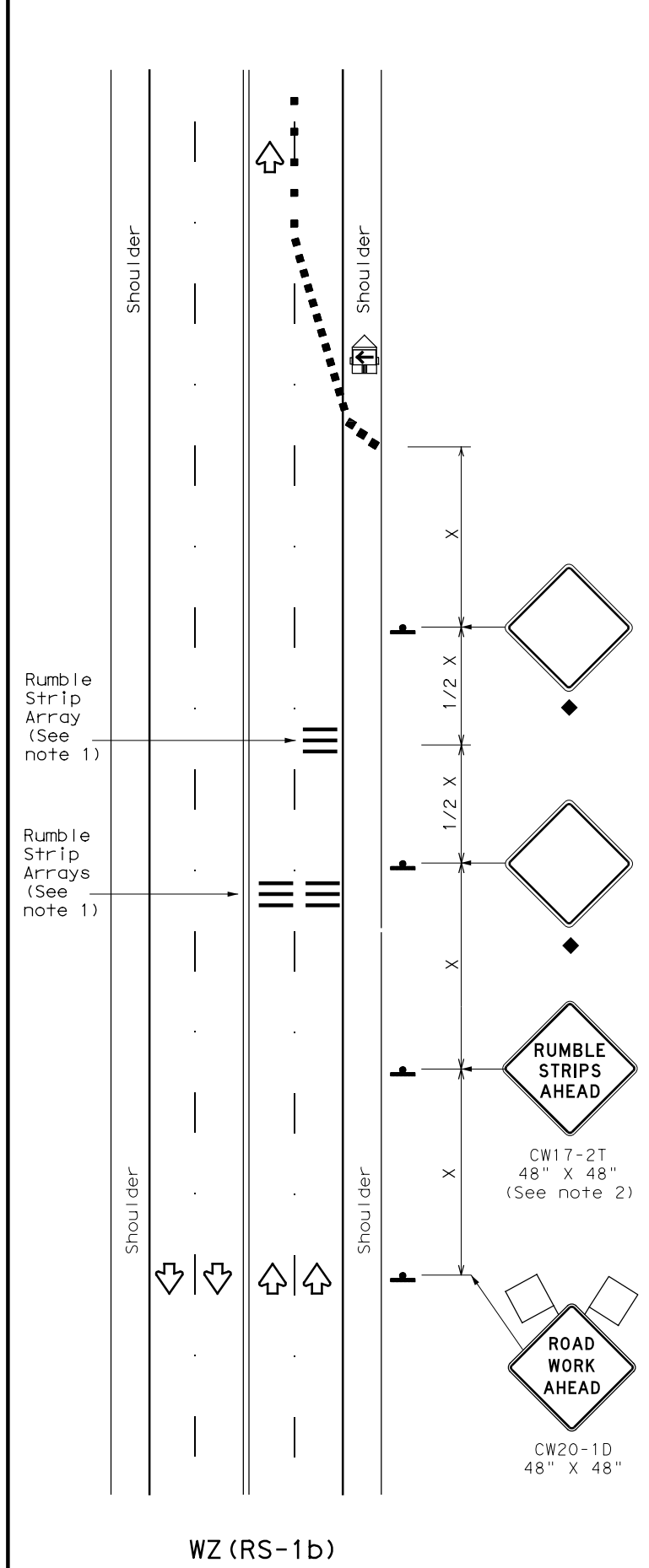

RUMBLE STRIPS FOR LANE CLOSURE ON CONVENTIONAL ROADWAY

GENERAL NOTES

- Each Rumble Strip Array should consist of three rumble strips spaced center to center at the spacing shown in Table 2, placed transverse across the lane at locations shown.
- The CW17-2T "RUMBLE STRIPS AHEAD" sign should be located after the CW20-1D "ROAD WORK AHEAD" sign and spaced as shown. If traffic is observed to be queuing, or is expected to queue beyond the Rumble Strips, the CW17-2T sign and the first Rumble Strip Array may be located upstream of the CW20-1D sign as necessary to provide needed warning.
- Temporary Rumble Strips will be considered subsidiary to Item 502, and shall be a product listed on the Compliant Work Zone Traffic Control Devices.
- Remove Temporary Rumble Strips before removing the advanced warning signs.
- Temporary Rumble Strips should not be used on horizontal curves, loose gravel, soft or bleeding asphalt, heavily rutted pavements or unpaved surfaces.
- Temporary Rumble Strips shall be installed and maintained as per manufacturer's recommendations.
- This standard sheet shall be used in conjunction with other appropriate TCP standard, TMUTCD typical application or project specific detail for the project.
- The one-lane two-way application may utilize a flagger, an Automated Flagger Assistance Device (AFAD) or a Portable Traffic Signal (PTS).
- Replace defective Temporary Rumble Strips as directed by the Engineer.
- Temporary Rumble Strips may be used on freeways or expressways based on engineering judgment and written direction from the Engineer.

TABLE 2	
Speed	Approximate distance between strips in an array
≤ 40 MPH	10'
> 40 MPH & ≤ 55 MPH	15'
= 60 MPH	20'
≥ 65 MPH	* 35'+

LEGEND			
	Type 3 Barricade		Channelizing Devices
	Heavy Work Vehicle		Truck Mounted Attenuator (TMA)
	Trailer Mounted Flashing Arrow Panel		Portable Changeable Message Sign (PCMS)
	Sign		Traffic Flow
	Flag		Flagger

Posted Speed *	Formula	Minimum Desirable Taper Lengths **			Suggested Maximum Spacing of Channelizing Devices		Minimum Sign Spacing "X" Distance	Suggested Longitudinal Buffer Space "B"
		10' Offset	11' Offset	12' Offset	On a Taper	On a Tangent		
30	L = WS ² / 60	150'	165'	180'	30'	60'	120'	90'
35		205'	225'	245'	35'	70'	160'	120'
40		265'	295'	320'	40'	80'	240'	155'
45	L = WS	450'	495'	540'	45'	90'	320'	195'
50		500'	550'	600'	50'	100'	400'	240'
55		550'	605'	660'	55'	110'	500'	295'
60		600'	660'	720'	60'	120'	600'	350'
65		650'	715'	780'	65'	130'	700'	410'
70		700'	770'	840'	70'	140'	800'	475'
75		750'	825'	900'	75'	150'	900'	540'

* Conventional Roads Only
 ** Taper lengths have been rounded off.
 L=Length of Taper (FT) W=Width of Offset (FT)
 S=Posted Speed (MPH)

TYPICAL USAGE				
MOBILE	SHORT DURATION	SHORT TERM STATIONARY	INTERMEDIATE TERM STATIONARY	LONG TERM STATIONARY
	✓	✓		

◆ Signs are for illustrative purposes only. Signs required may vary depending on the TCP, TMUTCD Typical Application, or project specific details for the project.

* For posted speeds in excess of 65 MPH, it is recommended that spacing is increased as speed limits increase. Increasing space between rumble strips will improve effectiveness.

Texas Department of Transportation
 Traffic Safety Division Standard

TEMPORARY RUMBLE STRIPS

WZ (RS) -22

FILE: wzrs22.dgn	DN: TxDOT	CK: TxDOT	DW: TxDOT	CK: TxDOT
© TxDOT November 2012	CONT	SECT	JOB	HIGHWAY
REVISIONS	0910	16	180	SH 64, Etc.
2-14 1-22 4-16	DIST	COUNTY	SHEET NO.	
	TYL	SMITH, Etc.	18	

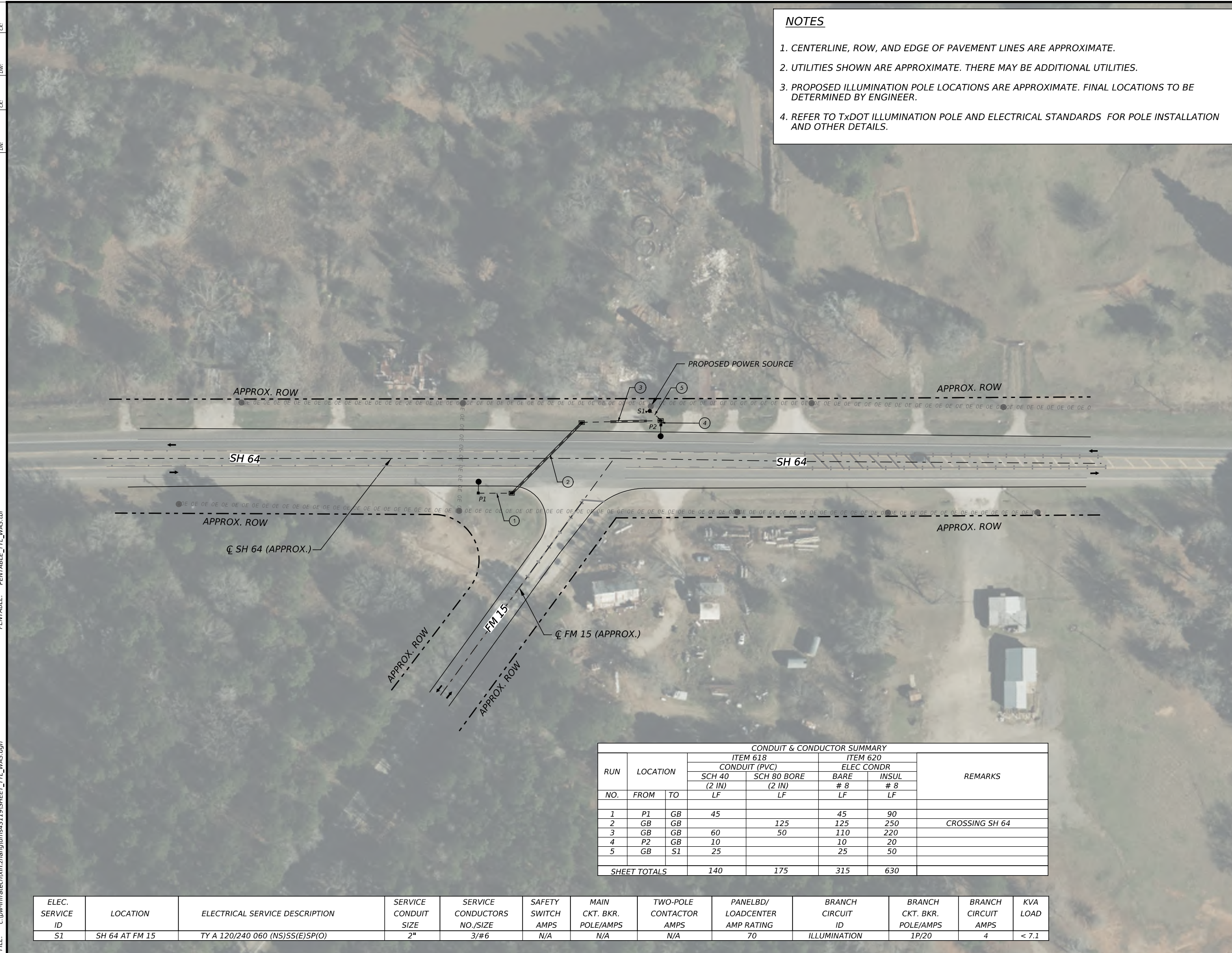

NOTES

1. CENTERLINE, ROW, AND EDGE OF PAVEMENT LINES ARE APPROXIMATE.
2. UTILITIES SHOWN ARE APPROXIMATE. THERE MAY BE ADDITIONAL UTILITIES.
3. PROPOSED ILLUMINATION POLE LOCATIONS ARE APPROXIMATE. FINAL LOCATIONS TO BE DETERMINED BY ENGINEER.
4. REFER TO TXDOT ILLUMINATION POLE AND ELECTRICAL STANDARDS FOR POLE INSTALLATION AND OTHER DETAILS.

- LEGEND**
- ▣ PROP TYPE A GROUND BOX WITH APRON
 - PROP ELECTRICAL SERVICE
 - PROP LIGHT POLE (TY SA 50T - 8) (400W EQ)
 - PROP LIGHT POLE (TY SA 50T - 12) (400W EQ)
 - PROP CONDUIT (TRENCH)
 - ==== PROP CONDUIT (BORE)
 - ⊗ CONDUIT RUN NUMBER
 - ➔ DIRECTION OF TRAVEL
 - - - - APPROXIMATE CENTERLINE
 - - - - APPROXIMATE ROW LINE

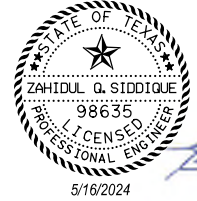
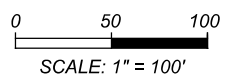

NO.	DATE	REVISION	APPROVED



ILLUMINATION LAYOUT

SH 64 AT FM 15
SMITH COUNTY

CONT	SECT	JOB	HIGHWAY
0910	16	180	SH 64, Etc.
DIST		COUNTY	SHEET NO.
TYL		SMITH, Etc.	19

RUN NO.	LOCATION FROM TO		CONDUIT & CONDUCTOR SUMMARY				REMARKS
			ITEM 618 CONDUIT (PVC)		ITEM 620 ELEC CONDR		
			SCH 40 (2 IN) LF	SCH 80 BORE (2 IN) LF	BARE # 8 LF	INSUL # 8 LF	
1	P1	GB	45		45	90	CROSSING SH 64
2	GB	GB		125	125	250	
3	GB	GB	60	50	110	220	
4	P2	GB	10		10	20	
5	GB	S1	25		25	50	
SHEET TOTALS			140	175	315	630	

ELEC. SERVICE ID	LOCATION	ELECTRICAL SERVICE DESCRIPTION	SERVICE CONDUIT SIZE	SERVICE CONDUCTORS NO./SIZE	SAFETY SWITCH AMPS	MAIN CKT. BKR. POLE/AMPS	TWO-POLE CONTACTOR AMPS	PANELBD/LOADCENTER AMP RATING	BRANCH CIRCUIT ID	BRANCH CKT. BKR. POLE/AMPS	BRANCH CIRCUIT AMPS	KVA LOAD
S1	SH 64 AT FM 15	TY A 120/240 060 (NS)SS(E)SP(O)	2"	3/#6	N/A	N/A	N/A	70	ILLUMINATION	1P/20	4	< 7.1



NOTES

1. CENTERLINE, ROW, AND EDGE OF PAVEMENT LINES ARE APPROXIMATE.
2. UTILITIES SHOWN ARE APPROXIMATE. THERE MAY BE ADDITIONAL UTILITIES.
3. PROPOSED ILLUMINATION POLE LOCATIONS ARE APPROXIMATE. FINAL LOCATIONS TO BE DETERMINED BY ENGINEER.
4. REFER TO TXDOT ILLUMINATION POLE AND ELECTRICAL STANDARDS FOR POLE INSTALLATION AND OTHER DETAILS.

- LEGEND**
- ▣ PROP TYPE A GROUND BOX WITH APRON
 - PROP ELECTRICAL SERVICE
 - PROP LIGHT POLE (TY SA 50T - 8) (400W EQ)
 - PROP LIGHT POLE (TY SA 50T - 12) (400W EQ)
 - PROP CONDUIT (TRENCH)
 - ==== PROP CONDUIT (BORE)
 - ⊗ CONDUIT RUN NUMBER
 - ➔ DIRECTION OF TRAVEL
 - - - - - APPROXIMATE CENTERLINE
 - - - - - APPROXIMATE ROW LINE

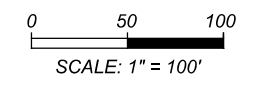

CONDUIT & CONDUCTOR SUMMARY							REMARKS
RUN NO.	LOCATION FROM TO		ITEM 618 CONDUIT (PVC)		ITEM 620 ELEC CONDR		
			SCH 40 (2 IN) LF	SCH 80 BORE (2 IN) LF	BARE # 8 LF	INSUL # 8 LF	
1	P1	GB	15		15	30	
2	GB	GB		140	140	280	CROSSING SH 64
3	P2	GB	15		15	30	
4	GB	GB		145	145	290	CROSSING FM 848
5	GB	S2	40		40	80	
SHEET TOTALS			70	285	355	710	

ELEC. SERVICE ID	LOCATION	ELECTRICAL SERVICE DESCRIPTION	SERVICE CONDUIT SIZE	SERVICE CONDUCTORS NO./SIZE	SAFETY SWITCH AMPS	MAIN CKT. BKR. POLE/AMPS	TWO-POLE CONTACTOR AMPS	PANELBD/LOADCENTER AMP RATING	BRANCH CIRCUIT ID	BRANCH CKT. BKR. POLE/AMPS	BRANCH CIRCUIT AMPS	KVA LOAD
S2	SH 64 AT FM 848	TY A 120/240 060 (NS)SS(E)SP(O)	2"	3/#6	N/A	N/A	N/A	70	ILLUMINATION	1P/20	4	< 7.1

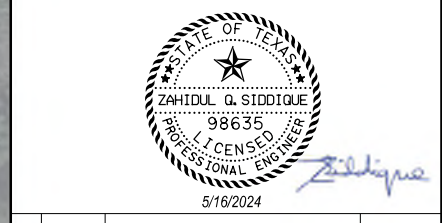

NO.	DATE	REVISION	APPROVED



ILLUMINATION LAYOUT

SH 64 AT FM 848

SMITH COUNTY

SHEET 1 OF 1

CONT	SECT	JOB	HIGHWAY
0910	16	180	SH 64, Etc.
DIST	COUNTY	SHEET NO.	
TYL	SMITH, Etc.	20	

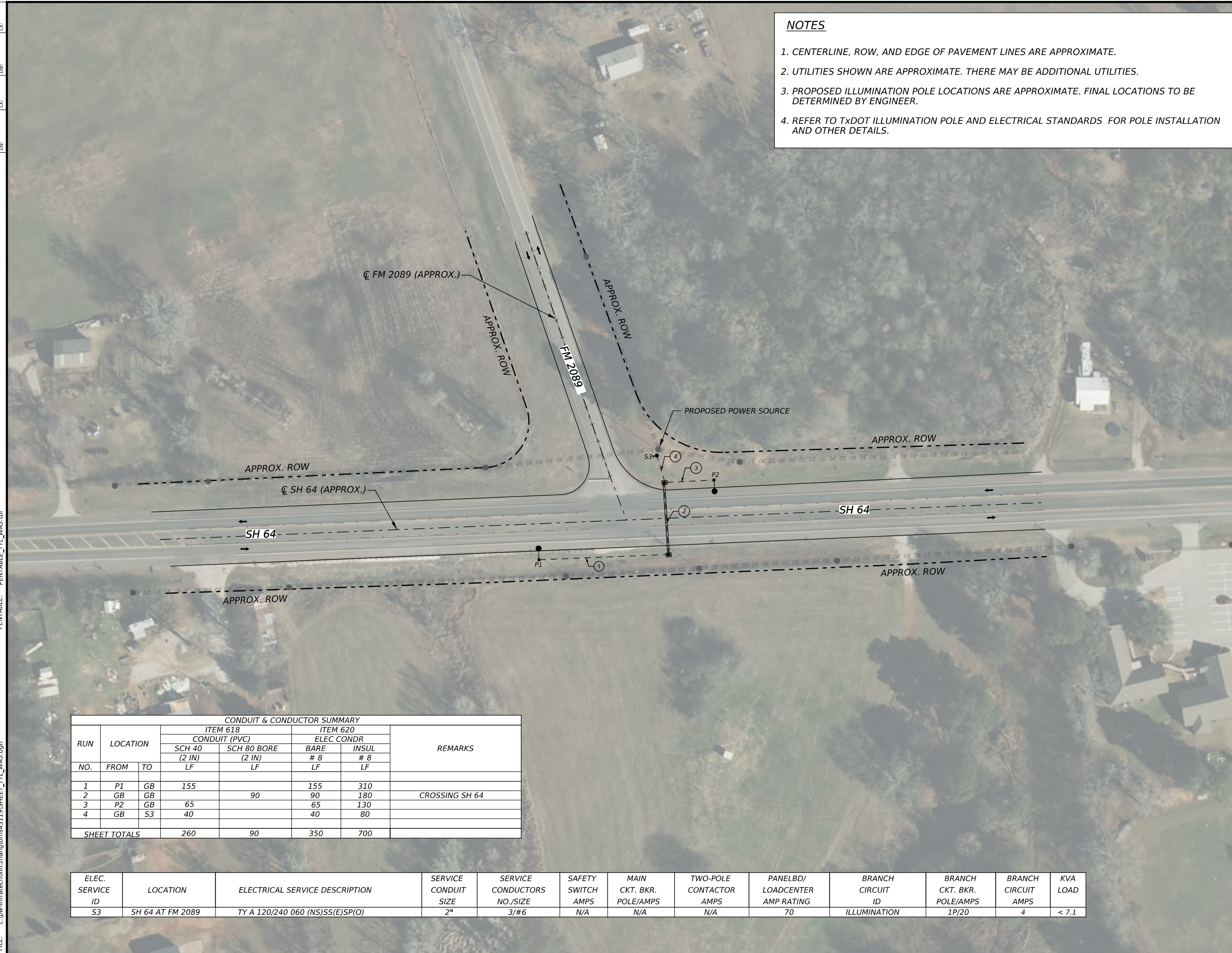

NOTES

- CENTERLINE, ROW, AND EDGE OF PAVEMENT LINES ARE APPROXIMATE.
- UTILITIES SHOWN ARE APPROXIMATE. THERE MAY BE ADDITIONAL UTILITIES.
- PROPOSED ILLUMINATION POLE LOCATIONS ARE APPROXIMATE. FINAL LOCATIONS TO BE DETERMINED BY ENGINEER.
- REFER TO TXDOT ILLUMINATION POLE AND ELECTRICAL STANDARDS FOR POLE INSTALLATION AND OTHER DETAILS.

- LEGEND**
- ▣ PROP TYPE A GROUND BOX WITH APRON
 - PROP ELECTRICAL SERVICE
 - PROP LIGHT POLE (TY SA 50T - 8) (400W EQ)
 - PROP LIGHT POLE (TY SA 50T - 12) (400W EQ)
 - PROP CONDUIT (TRENCH)
 - === PROP CONDUIT (BORE)
 - ⊗ CONDUIT RUN NUMBER
 - ➔ DIRECTION OF TRAVEL
 - - - - APPROXIMATE CENTERLINE
 - - - - APPROXIMATE ROW LINE

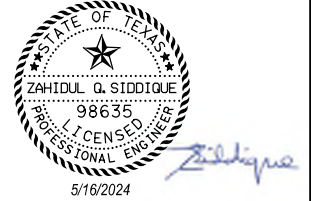
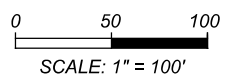

NO.	DATE	REVISION	APPROVED



ILLUMINATION LAYOUT

SH 64 AT FM 2089

SMITH COUNTY

SHEET 1 OF 1

CONT	SECT	JOB	HIGHWAY
0910	16	180	SH 64, Etc.
DIST		COUNTY	SHEET NO.
TYL		SMITH, Etc.	21

CONDUIT & CONDUCTOR SUMMARY							REMARKS
RUN NO.	LOCATION FROM TO		ITEM 618 CONDUIT (PVC)		ITEM 620 ELEC CONDR		
			SCH 40 (2 IN) LF	SCH 80 BORE (2 IN) LF	BARE # 8 LF	INSUL # 8 LF	
1	P1	GB	155		155	310	CROSSING SH 64
2	GB	GB		90	90	180	
3	P2	GB	65		65	130	
4	GB	S3	40		40	80	
SHEET TOTALS			260	90	350	700	

ELEC. SERVICE ID	LOCATION	ELECTRICAL SERVICE DESCRIPTION	SERVICE CONDUIT SIZE	SERVICE CONDUCTORS NO./SIZE	SAFETY SWITCH AMPS	MAIN CKT. BKR. POLE/AMPS	TWO-POLE CONTACTOR AMPS	PANELBD/LOADCENTER AMP RATING	BRANCH CIRCUIT ID	BRANCH CKT. BKR. POLE/AMPS	BRANCH CIRCUIT AMPS	KVA LOAD
S3	SH 64 AT FM 2089	TY A 120/240 060 (NS)SS(E)SP(O)	2"	3/#6	N/A	N/A	N/A	70	ILLUMINATION	1P/20	4	< 7.1

NOTES

1. CENTERLINE, ROW, AND EDGE OF PAVEMENT LINES ARE APPROXIMATE.
2. UTILITIES SHOWN ARE APPROXIMATE. THERE MAY BE ADDITIONAL UTILITIES.
3. PROPOSED ILLUMINATION POLE LOCATIONS ARE APPROXIMATE. FINAL LOCATIONS TO BE DETERMINED BY ENGINEER.
4. REFER TO TxDOT ILLUMINATION POLE AND ELECTRICAL STANDARDS FOR POLE INSTALLATION AND OTHER DETAILS.

LEGEND

- ☐ PROP TYPE A GROUND BOX WITH APRON
- PROP ELECTRICAL SERVICE
- PROP LIGHT POLE (TY SA 50T - 8) (400W EQ)
- PROP LIGHT POLE (TY SA 50T - 12) (400W EQ)
- PROP CONDUIT (TRENCH)
- === PROP CONDUIT (BORE)
- ⊗ CONDUIT RUN NUMBER
- ➔ DIRECTION OF TRAVEL
- - - - APPROXIMATE CENTERLINE
- - - - APPROXIMATE ROW LINE

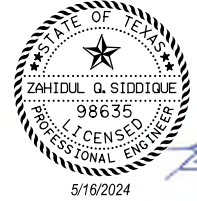
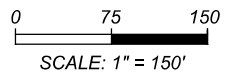

NO.	DATE	REVISION	APPROVED



ILLUMINATION LAYOUT

FM 850 AT US 259
RUSK COUNTY

SHEET 1 OF 1

CONT	SECT	JOB	HIGHWAY
0910	16	180	SH 64, Etc.
DIST		COUNTY	SHEET NO.
TYL		SMITH, Etc.	22

PLOT DRIVER: TXDOT_PDF_BW_LEVELS.plt;g
PENTABLE_TYL_WA3.tbl

DATE: 5/16/2024 9:32:16 AM
FILE: c:\pw-infratech\in.zhang\dms43119\SHEET_TYL_WA3.dgn

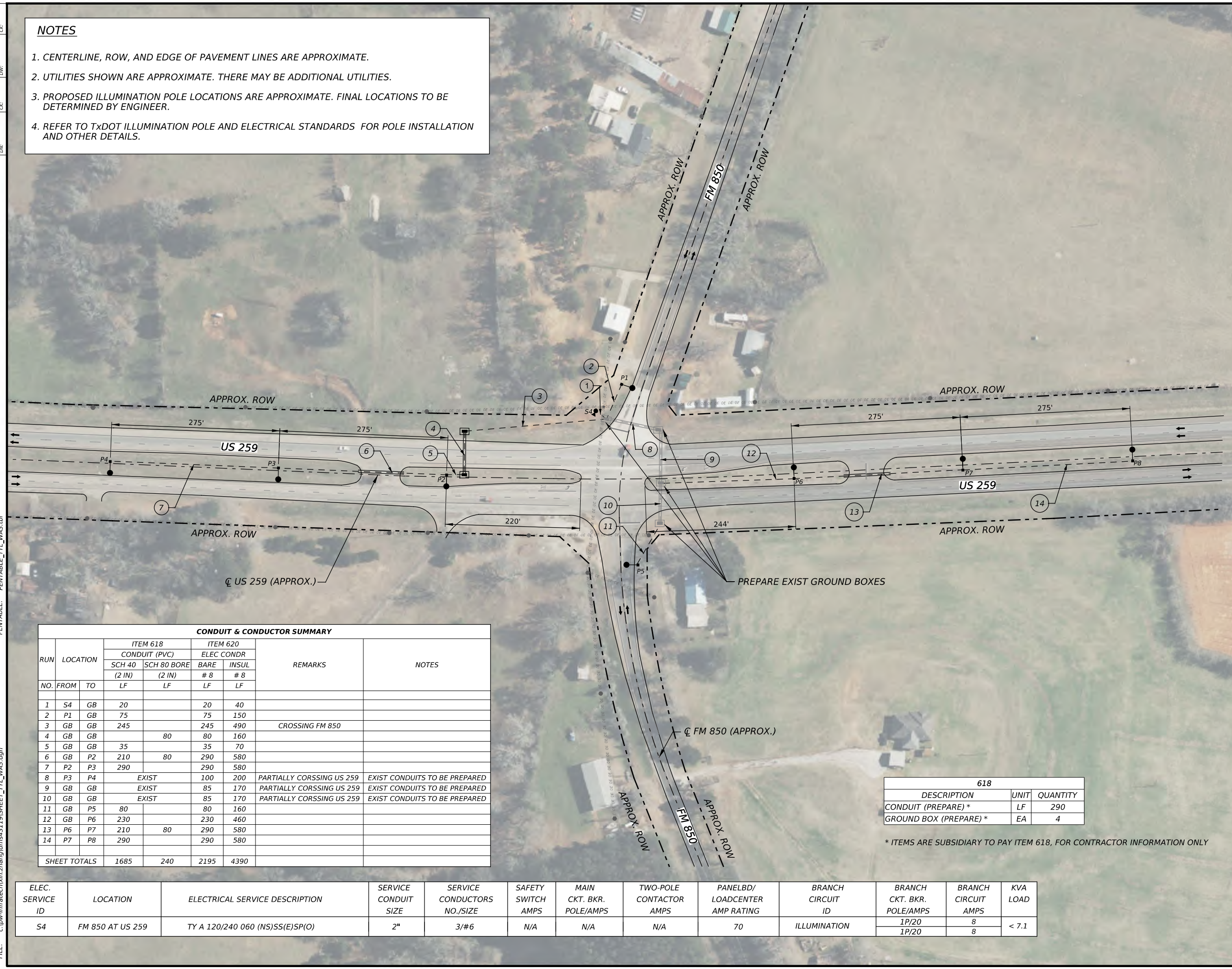

CONDUIT & CONDUCTOR SUMMARY

RUN NO.	LOCATION		ITEM 618		ITEM 620		REMARKS	NOTES
			CONDUIT (PVC)		ELEC CONDR			
			SCH 40 (2 IN)	SCH 80 BORE (2 IN)	BARE # 8	INSUL # 8		
1	S4	GB	20		20	40		
2	P1	GB	75		75	150		
3	GB	GB	245		245	490	CROSSING FM 850	
4	GB	GB		80	80	160		
5	GB	GB	35		35	70		
6	GB	P2	210	80	290	580		
7	P2	P3	290		290	580		
8	P3	P4	EXIST		100	200	PARTIALLY CORSSING US 259	EXIST CONDUITS TO BE PREPARED
9	GB	GB	EXIST		85	170	PARTIALLY CORSSING US 259	EXIST CONDUITS TO BE PREPARED
10	GB	GB	EXIST		85	170	PARTIALLY CORSSING US 259	EXIST CONDUITS TO BE PREPARED
11	GB	P5	80		80	160		
12	GB	P6	230		230	460		
13	P6	P7	210	80	290	580		
14	P7	P8	290		290	580		
SHEET TOTALS			1685	240	2195	4390		

618		
DESCRIPTION	UNIT	QUANTITY
CONDUIT (PREPARE) *	LF	290
GROUND BOX (PREPARE) *	EA	4

* ITEMS ARE SUBSIDIARY TO PAY ITEM 618, FOR CONTRACTOR INFORMATION ONLY

ELEC. SERVICE ID	LOCATION	ELECTRICAL SERVICE DESCRIPTION	SERVICE CONDUIT SIZE	SERVICE CONDUCTORS NO./SIZE	SAFETY SWITCH AMPS	MAIN CKT. BKR. POLE/AMPS	TWO-POLE CONTACTOR AMPS	PANELBD/ LOADCENTER AMP RATING	BRANCH CIRCUIT ID	BRANCH CKT. BKR. POLE/AMPS	BRANCH CIRCUIT AMPS	KVA LOAD
S4	FM 850 AT US 259	TY A 120/240 060 (NS)SS(E)SP(O)	2"	3/#6	N/A	N/A	N/A	70	ILLUMINATION	1P/20 1P/20	8 8	< 7.1

GENERAL NOTES FOR ALL ELECTRICAL WORK

- The location of all conduits, junction boxes, ground boxes, and electrical services is diagrammatic and may be shifted to accommodate field conditions.
- Provide new and unused materials. Ensure that all materials and installations comply with the applicable articles of the National Electrical Code (NEC), TxDOT standards and specifications, National Electrical Manufacturers Association (NEMA), and are listed by Underwriters Laboratories (UL) or a Nationally Recognized Testing Lab (NRTL). NRTLs such as Canadian Standard Association (CSA), Intertek Testing Services NA Inc., or FM Approvals LLC can be considered equivalent to UL. Where reference is made to NEMA listed devices, International Electrotechnical Commission (IEC) listed devices will not be considered an acceptable equal to a NEMA listed device. Acceptable devices may have both a NEMA and IEC listing. Faulty fabrication or poor workmanship in any material, equipment, or installation is justification for rejection. Replace or reinstall rejected material or equipment at no additional cost to the Department.
- Miscellaneous nuts, bolts and hardware, except for high strength bolts, may be stainless steel when plans specify galvanized, provided the bolt size is 1/2 in. or less in diameter.
- Provide the following test equipment as required by the Engineer to confirm compliance with the contract and the NEC: voltmeter, ammeter, megohm meter (1000 volt DC), ground resistance tester, torque wrenches, and torque screwdrivers. Ensure all equipment has been properly calibrated within the last year. Provide calibration certification to the Engineer upon request. Operate test equipment during inspection as requested by the Engineer.
- Install grounding as shown on the plans and in accordance with the NEC. Ensure all metallic conduits; metal poles; luminaires; and metal enclosures are bonded to the equipment grounding conductor. Provide stranded bare copper or green insulated grounding conductors. Ground rods, connectors, and bonding jumpers are subsidiary to the various bid items.
- When required by the Engineer, notify the Department in writing of materials from the Material Producers List (MPL) intended for use on each project. Prequalified materials are listed on the MPL on TxDOT's website under "Roadway Illumination and Electrical Supplies." No substitutions will be allowed for materials on this list.

CONDUIT

A. MATERIALS

- Provide conduit, junction boxes, fittings, and hardware as per TxDOT Departmental Material Specification (DMS) 11030 "Conduit" and Item 618 "Conduit" of TxDOT's "Standard Specifications For Construction And Maintenance Of Highways, Streets, And Bridges," latest edition. Provide conduits listed under Item 618 on the MPL under "Roadway Illumination and Electrical Supplies." Provide conduit types according to the descriptive code or as shown on the plans. Do not substitute other types of conduits for those shown. Provide liquidtight flexible metal conduit (LFMC) when flexible conduit is called for on galvanized steel rigid metallic conduit (RMC) systems. Provide liquidtight flexible nonmetallic conduit (LFNC) when flexible conduit is called for on polyvinyl chloride (PVC) systems.
- Provide galvanized steel RMC for all exposed conduits, unless otherwise shown on the plans. Properly bond all metal conduits.
- Unless otherwise shown on the plans, provide junction boxes with a minimum size as shown in the following table, which applies to the greatest number of conductors entering the box through one conduit with no more than four conduits per box. When a mixture of conductor sizes is present, count the conductors as if all are of the larger size. For situations not applicable to the table, size junction boxes in accordance with NEC.

AWG	3 CONDUCTORS	5 CONDUCTORS	7 CONDUCTORS
#1	10" x 10" x 4"	12" x 12" x 4"	16" x 16" x 4"
#2	8" x 8" x 4"	10" x 10" x 4"	12" x 12" x 4"
#4	8" x 8" x 4"	10" x 10" x 4"	10" x 10" x 4"
#6	8" x 8" x 4"	8" x 8" x 4"	10" x 10" x 4"
#8	8" x 8" x 4"	8" x 8" x 4"	8" x 8" x 4"

- Junction boxes with an internal volume of less than 100 cu. in. and supported by entering raceways must have threaded entries or hubs identified for the intended purpose and supported by connection of two or more rigid metal conduits. Secure conduit within 3 ft. of the enclosure or within 18 in. of the enclosure if all conduit entries are on the same side. Mechanically secure all junction boxes with an internal volume greater than 100 cu. inches.
- Provide hot dipped galvanized cast iron or sand cast aluminum outlet boxes for junction boxes containing only 10 AWG or 12 AWG conductors. Do not use die cast aluminum boxes. Size outlet boxes according to the NEC.
- Do not use intermediate metal conduit (IMC) or electrical metallic tubing (EMT) unless specifically required by the plan sheets. When EMT is called for, provide junction boxes made from galvanized steel sheeting, listed and approved for outdoor use, unless otherwise noted on the plans. Size all galvanized steel junction boxes in accordance with the NEC. Provide junction boxes for IMC conduit systems that meet the same requirements for junction boxes used with RMC systems.
- Provide PVC junction boxes intended for outdoor use on PVC conduit systems, unless otherwise noted on the plans.

- Provide PVC elbows in PVC conduit systems, unless otherwise shown on the plans. Use only a flat, high tensile strength polyester fiber pull tape for pulling conductors through the PVC conduit system. When galvanized steel RMC elbows are specifically called for in the plans and any portion of the RMC elbow is buried less than 18 in., ground the RMC elbow by means of a grounding bushing on a rigid metal extension. Grounding of the rigid metal elbow is not required if the entire RMC elbow is encased in a minimum of 2 in. of concrete. PVC extensions are allowed on these concrete encased rigid metal elbows. RMC or PVC elbows are subsidiary to various bid items.
- When required, provide High-Density Polyethylene (HDPE) conduit with factory installed internal conductors according to Item 622 "Duct Cable." At the Contractor's request and with approval by the Engineer, substitute HDPE conduit with no conductors for bored schedule 40 or schedule 80 PVC conduit bid under Item 618. Ensure bored HDPE substituted for PVC is schedule 40 and of the same size PVC called for in the plans. Ensure the substituted HDPE meets the requirements of Item 622, except that the conduit is supplied without factory-installed conductors. Make the transition of the HDPE conduit to PVC (or RMC elbow when required) at the bore pit. Provide conduit of the size and schedule as shown on the plans. Do not extend substituted conduit into ground boxes or foundations. Provide PVC or galvanized steel RMC elbows as called for at all ground boxes and foundations.
- Use two-hole straps when supporting 2 in. and larger conduits. On electrical service poles, properly sized stainless steel or hot dipped galvanized one-hole standoff straps are allowed on the service riser conduit.

B. CONSTRUCTION METHODS

- Provide and install expansion joint conduit fittings on all structure-mounted conduits at the structure's expansion joints to allow for movement of the conduit. In addition, provide and install expansion joint fittings on all continuous runs of galvanized steel RMC conduit externally exposed on structures such as bridges at maximum intervals of 150 ft. When requested by the project Engineer, supply manufacturer's specification sheet for expansion joint conduit fittings. Repair or replace expansion joint fittings that do not allow for movement at no additional cost to the Department. Provide the method of determining the amount of expansion to the Engineer upon request. Do not use LFMC or LFNC as a substitute for the required expansion conduit fittings.
- Space all conduit supports at maximum intervals of 5 ft. Install conduit spacers when attaching metal conduit to surface of concrete structures. See "Conduit Mounting Options" on ED(2). Install conduit support within 3 ft. of all enclosures and conduit terminations.
- Do not attach conduit supports directly to pre-stressed concrete beams except as shown specifically in the plans or as approved by the Engineer.
- Unless otherwise shown on the plans, jack or bore conduit placed beneath existing roadways, driveways, sidewalks, or after the base or surfacing operation has begun. Backfill and compact the bore pits below the conduit per Item 476 "Jacking, Boring, or Tunneling Pipe or Box" prior to installing conduit or duct cable to prevent bending of the connections.
- When placing conduit in the sub-grade of new roadways, backfill all trenches with excavated material unless otherwise noted on the plans. When placing conduit in the sub-base of new roadways, backfill all trenches with cement-stabilized base as per requirements of Items 110 "Excavation", 400 "Excavation and Backfill for Structures", 401 "Flowable Backfill", 402 "Trench Excavation Protection", and 403 "Temporary Special Shoring."
- Provide and place warning tape approximately 10 in. above all trenched conduit as per Item 618.
- During construction, temporarily cap or plug open ends of all conduit and raceways immediately after installation to prevent entry of dirt, debris and animals. Temporary caps constructed of durable duct tape are allowed. Tightly fix the tape to the conduit opening. Clean out the conduit and prove it clear in accordance with Item 618 prior to installing any conductors.
- Ensure conduit entry into the top of any enclosure is waterproof by installing conduit sealing hubs or using boxes with threaded bosses. This includes surface mounted safety switches, meter cans, service enclosures, auxiliary enclosures and junction boxes. Grounding bushings on water tight sealing hubs are not required.
- Fit the ends of all PVC conduit terminations with bushings or bell end fittings. Provide and install a grounding type bushing on all metal conduit terminations.
- Install a bonding jumper from each grounding bushing to the nearest ground rod, grounding lug, or equipment grounding conductor. Ensure all bonding jumpers are the same size as the equipment grounding conductor. Bonding of conduit used as a casing under roadways for duct cable is not required, if the duct extends the full length through the casing.
- At all electrical services, install a 6 AWG solid copper grounding electrode conductor.
- Place conduits entering ground boxes so that the conduit openings are between 3 in. and 6 in. from the bottom of the box. See the ground box detail on sheet ED(4).
- Seal ends of all conduits with duct seal, expandable foam, or by other methods approved by the Engineer. Seal conduit immediately after completion of conductor installation and pull tests. Do not use duct tape as a permanent conduit sealant. Do not use silicone caulk as a conduit sealant.
- File smooth the out ends of all mounting strut and conduit. Before installing, paint the field out ends of all mounting strut and RMC (threaded or non-threaded) with zinc rich paint (94% or more zinc content) to alleviate overspray. Use zinc rich paint to touch up galvanized material as allowed under Item 445 "Galvanizing." Do not paint non-galvanized material with a zinc rich paint as an alternative for materials required to be galvanized.

DISCLAIMER: The use of this standard is governed by the "Texas Engineering Practice Act". No warranty of any kind is made by TxDOT for any purpose whatsoever. TxDOT assumes no responsibility for the conversion of this standard to other formats or for incorrect results or damages resulting from its use.

DATE: 5/16/2024 9:32:31 AM
FILE: c:\pw-InfraTech\Lin.Zhang\dms47076\ed1-14 (1).dgn

				Traffic Operations Division Standard	
<h1>ELECTRICAL DETAILS CONDUITS & NOTES</h1>					
<h2>ED(1)-14</h2>					
FILE:	ed1-14.dgn	DN:	CK:	DW:	CK:
© TxDOT	October 2014	CONT	SECT	JOB	HIGHWAY
REVISIONS		0910	16	180	SH 64, Etc.
		DIST	COUNTY		SHEET NO.
		TYL	SMITH, Etc.		23

ELECTRICAL CONDUCTORS

A. MATERIAL INFORMATION

1. Provide Type XHHW insulated conductors in accordance with Departmental Material Specification (DMS)11040 "Conductors" and Item 620 "Electrical Conductors." Provide conductors as listed on the Material Producers List (MPL) on the Department web site under "Roadway Illumination and Electrical Supplies" Item 620. Color code insulated conductors in conformance with the NEC. Identify grounded (neutral) conductors with white insulation. Identify grounding conductors (ground wires) with green insulation or bare conductors. Identify ungrounded (hot) conductors with any color insulation except green, white, or gray. Keep color scheme consistent throughout the wiring system. Identify conductors 6 American Wire Gauge (AWG) and smaller by continuous color jacket. Identify electrical conductors 4 AWG and larger by continuous color jacket or by colored tape. When identifying conductors with colored tape, mark at least 6 in. of the conductor's insulation with half laps of tape.
2. Provide a solid copper 6 AWG grounding electrode conductor to bond the electrical service equipment to the concrete encased grounding electrode or the ground rod at the service location. Connect the grounding electrode conductor to the ground rod with a UL listed connector in accordance with DMS 11040. Connect the grounding electrode conductor to the concrete encased grounding electrode as shown in the plans.
3. Where two or more circuits are present in one conduit or enclosure, permanently identify the conductors of each branch circuit by attaching a non-metallic tag around both circuit conductors at each accessible location. Provide tags with two straps, large enough to indicate circuit number, letter, or other identification as shown in the plans. Print circuit identification on the tag with a permanent marker.
4. Use listed compression or screw type pressure connectors, terminal blocks, or split bolt connectors for splicing as specified in DMS 11040. Use hot melt adhesive tape to fill the gap and seal the ends of heat shrink tubing. Provide UL listed gel-filled insulating splice covers. Splicing materials, insulating materials, breakaway disconnects, splice covers, and fuse holders are subsidiary to various bid items.

B. CONSTRUCTION METHODS

1. Use only a flat, high tensile strength polyester fiber pull tape for pulling conductors through the conduit system. After installing conductors in conduit, perform conductor pull test. If a conductor cannot be freely pulled, make any needed alterations or repairs at no additional cost to the department. Perform insulation resistance tests in accordance with Item 620. Coordinate with the Engineer to witness the tests.
2. Leave 2 ft. minimum, 3 ft. maximum length for each conductor up to the splice in ground boxes. Leave 3 ft. minimum, 4 ft. maximum length of conductor in ground boxes when pulled through with no splice. Leave 1 ft. minimum, 1.5 ft. maximum length of conductor at enclosures, weatherheads and pole bases.
3. Make splices only in junction boxes, ground boxes, pole bases, or electrical enclosures and use only listed compression or screw type pressure connectors, terminal blocks, or split bolt connectors. Insulate splices with heavy wall heat shrink tubing or gel-filled insulating splice covers to provide a watertight splice. Overlap conductor insulation with heat shrink tubing a minimum of 2 in. past both sides of the splice. Where heat shrink tubing may not shrink sufficiently to provide a watertight seal around the individual conductors, prior to heating the tubing, increase the diameter of the conductor insulation using hot melt adhesive tape to provide a watertight seal between the individual conductors and the heat shrink tubing. Ensure the tape extends past the heat shrink tubing. Use hot melt adhesive tape to fill the gap and seal the ends of heat shrink tubing. Heat shrink tubing that appears to have been burned, or overheated, is considered defective and must be replaced.
4. Size and install gel-filled insulating splice covers according to manufacturer's specifications when used in place of heat shrink tubing.
5. Wire nuts with factory applied waterproof sealant may be used for 8 AWG or smaller conductors in above ground junction boxes, but not in pole bases or ground boxes. Install wire nuts in an upright position to prevent the accumulation of water.
6. Support conductors in illumination poles with a J-hook at the top of the pole.
7. When terminating conductors, remove the insulation and jacketing material without nicking the individual strands of the conductor. Conductors with nicked individual conductor strands or removed strands will be considered damaged.
8. Replace conductors and cables that are damaged beyond repair or that fail an insulation resistance test at no additional cost to the department.
9. Do not repair damaged conductors with duct tape, electrical tape, or wire nuts. Use only approved splicing methods.
10. Do not terminate more than one conductor under a single connector, unless the connector is rated for multiple conductors. Do not exceed the pressure connector's listing for maximum number and size of conductors allowed.
11. Install breakaway connectors on conductors bid under Item 620 whenever those conductors pass through a breakaway support device. Follow manufacturer's instructions when terminating conductors to breakaway connectors. Properly torque threaded connections. Proper terminations are critical to the safe operation of breakaway devices. Trim waterproofing boots on breakaway connectors to fit snugly around the conductor to ensure waterproof connection. Only one conductor may enter a single opening in a boot. Provide waterproof boots with the correct number of openings. Leave unused openings factory sealed. Use prequalified breakaway connectors as shown on the MPL.

12. Provide and install a separate stranded equipment grounding conductor (EGC) in all conduits that contain circuit wiring of 50 volts or more. Unless shown elsewhere, size the EGC to be the same size as the largest current carrying conductor contained in the conduit. Ensure all EGCs are bonded together at every accessible location. For traffic signal installations, provide a minimum size 8 AWG EGC. The EGC is paid for under Item 620.

C. TEMPORARY WIRING

1. Install temporary conductors and electrical equipment in accordance with the NEC article "Temporary Installations" and Department standard sheets.
2. Provide a ground fault circuit interrupter (GFCI) for power outlets for portable electrical equipment, power tools, ice machines, ice storage bins and refrigerators located outdoors at grade. GFCI may be any one of the following: molded cord and plug set, receptacle, or circuit breaker type.
3. Use listed wire nuts with factory applied sealant for temporary wiring where approved.
4. Enclose conductor splices within a listed enclosure or ground box, or ensure the splices are more than 10 ft. above grade vertically and more than 5 ft. horizontally from any metal structure. Where installing temporary conductors in areas subject to vehicle traffic or mobile construction equipment, ensure the vertical clearance to ground is at least 18 ft. when measured at the lowest point. Ground messenger wires that support power conductors in conformance with the NEC.
5. Protect and when necessary repair any existing electrical conduits uncovered during the construction process in a timely manner and in conformance with the NEC.

GROUND RODS & GROUNDING ELECTRODES

A. MATERIAL INFORMATION

1. Provide and install a grounding electrode at electrical services. Provide ground rods according to DMS 11040 and the plans. Larger diameter or longer length rods may be called for in some specific locations, see the individual plans sheets. Concrete encased grounding electrodes may be called for in specific locations including electrical service, see individual plan sheets.

B. CONSTRUCTION METHODS

1. Furnish auxiliary ground rods for lightning protection and install in soil, concrete, or both, as called for in the plans. For ground rods installed in concrete, ensure the connection of the conductor to the ground rod is readily accessible for inspection or repairs. For ground rods installed in soil, ensure that the upper end is between 2 to 4 in. below finished grade.
2. Do not place ground rods in the same drilled hole as a timber pole.
3. Install ground rods so the imprinted part number is at the upper end of the rod.
4. Remove all non-conductive coatings such as concrete splatter from the rod at the clamp location.
5. Route all conductors as short and straight as possible for connection to lightning protection ground rods. When a bend is required, ensure a minimum radius bend of four inches for these conductors.
6. Unless otherwise called for in the plans, protect grounding electrode conductors with non-metallic conduit. When protecting grounding electrode conductors with metal conduit, provide and install a grounding type bushing and properly sized bonding jumper on each end of the metal conduit.
7. Written authorization is required before installing a ground rod in a horizontal trench for rocky soil or a solid rock bottom.

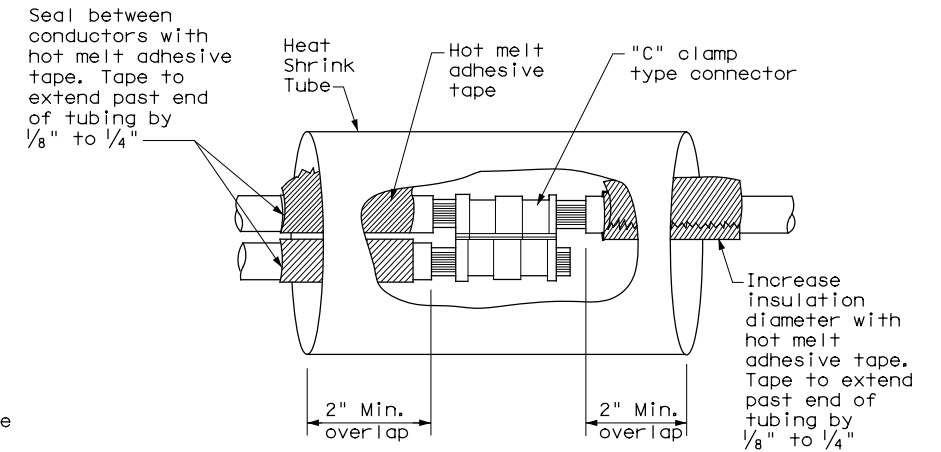

**SPLICE OPTION 1
Compression Type**

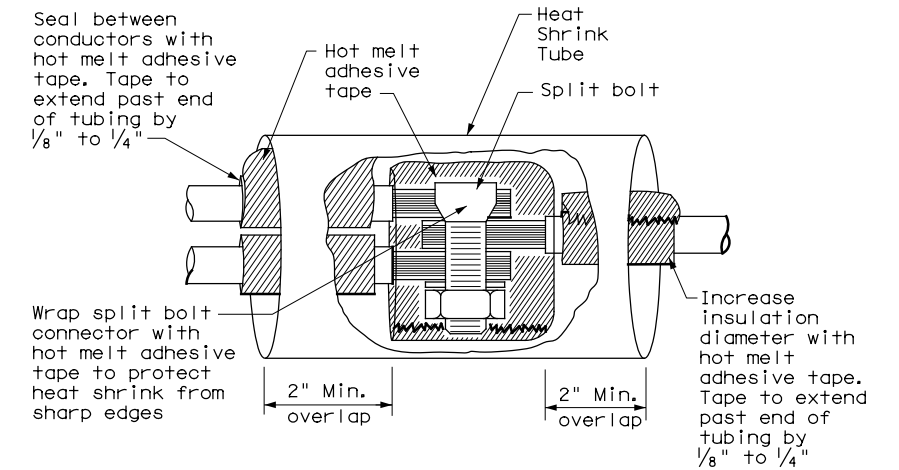

**SPLICE OPTION 2
Split Bolt Type**

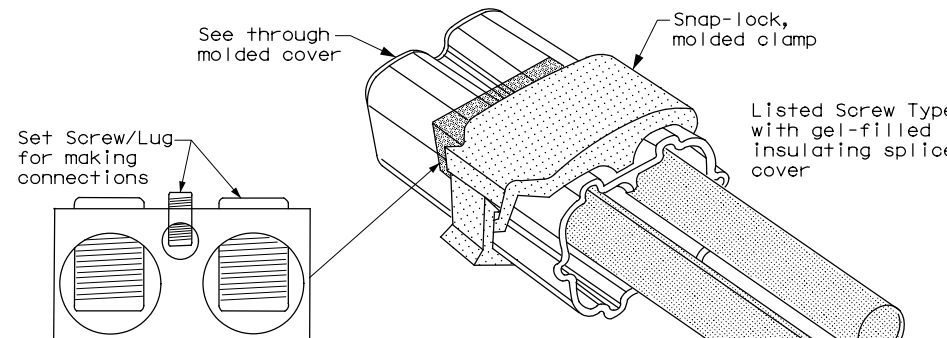

**SPLICE OPTION 3
Listed Screw Type**

DISCLAIMER: The use of this standard is governed by the "Texas Engineering Practice Act". No warranty of any kind is made by TxDOT for any purpose whatsoever. TxDOT assumes no responsibility for the conversion of this standard to other formats or for incorrect results or damages resulting from its use.

DATE: 5/16/2024 9:32:34 AM
FILE: c:\pw-Infra\tech\in.zhang\dms47076\ed3-14 (1).dgn

		Texas Department of Transportation		Traffic Operations Division Standard	
<h2>ELECTRICAL DETAILS CONDUCTORS</h2>					
<h3>ED(3)-14</h3>					
FILE:	ed3-14.dgn	DN:	TxDOT	CK:	TxDOT
© TxDOT	October 2014	CONT:	SECT:	JOB:	HIGHWAY
REVISIONS		0910	16	180	SH 64, Etc.
	DIST:	COUNTY:			SHEET NO.
	TYL	SMITH, Etc.			24

DISCLAIMER: The use of this standard is governed by the "Texas Engineering Practitioner Act". No warranty of any kind is made by TxDOT for any purpose whatsoever. TxDOT assumes no responsibility for the conversion of this standard to other formats or for incorrect results or damages resulting from its use.

DATE: 5/16/2024 9:32:38 AM
 FILE: c:\pw-InfraTech\In.Zhang\dms47076\ed4-14 (1).dgn

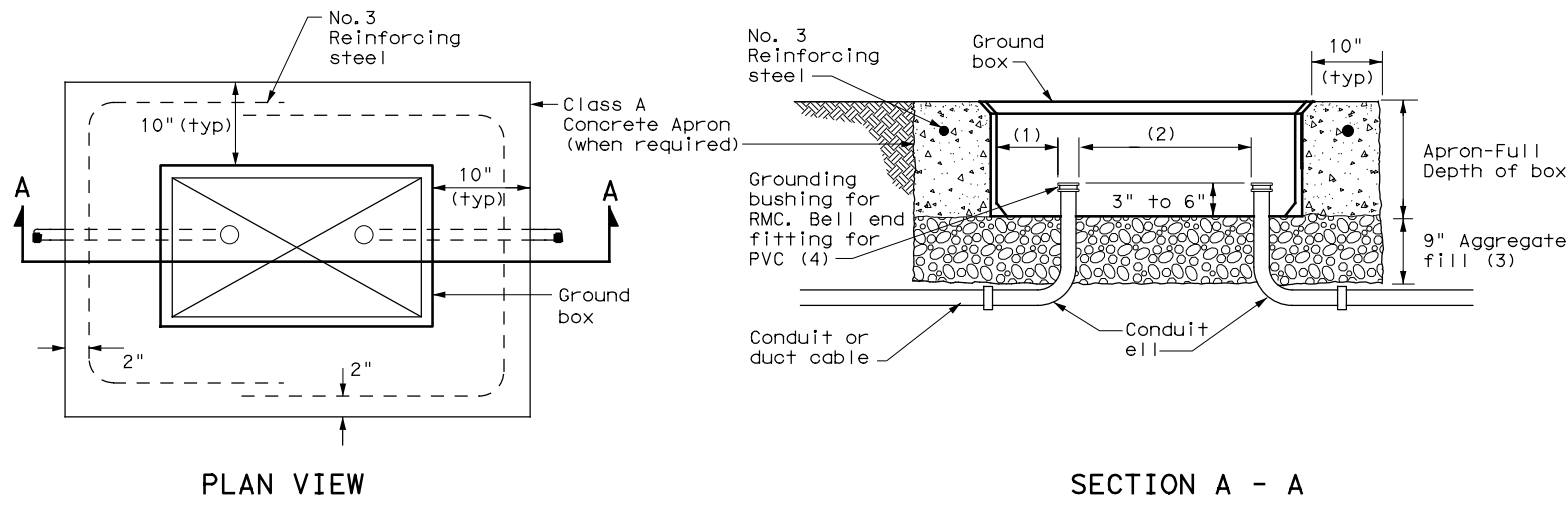

APRON FOR GROUND BOX

- (1) Uniformly space ends of conduits within the ground box. Position ends of conduits so that ground box walls do not interfere with the installation of grounding bushings or bell end fittings.
- (2) Maintain sufficient space between conduits to allow for proper installation of bushing.
- (3) Place aggregate under the box, not in the box. Aggregate should not encroach on the interior volume of the box.
- (4) Install a grounding bushing on the upper end of all RMC terminating in a ground box. Ground RMC elbows when any part of the elbow is less than 18 in. below the bottom of the ground box. Install a PVC bushing or bell end fitting on the upper end of all PVC conduits terminating in a ground box.

GROUND BOX DIMENSIONS	
TYPE	OUTSIDE DIMENSIONS (INCHES) (Width x Length X Depth)
A	12 X 23 X 11
B	12 X 23 X 22
C	16 X 29 X 11
D	16 X 29 X 22
E	12 X 23 X 17

GROUND BOX COVER DIMENSIONS								
TYPE	DIMENSIONS (INCHES)							
	H	I	J	K	L	M	N	P
A, B & E	23 1/4	23	13 3/4	13 1/2	9 7/8	5 1/8	1 3/8	2
C & D	30 1/2	30 1/4	17 1/2	17 1/4	13 1/4	6 3/4	1 3/8	2

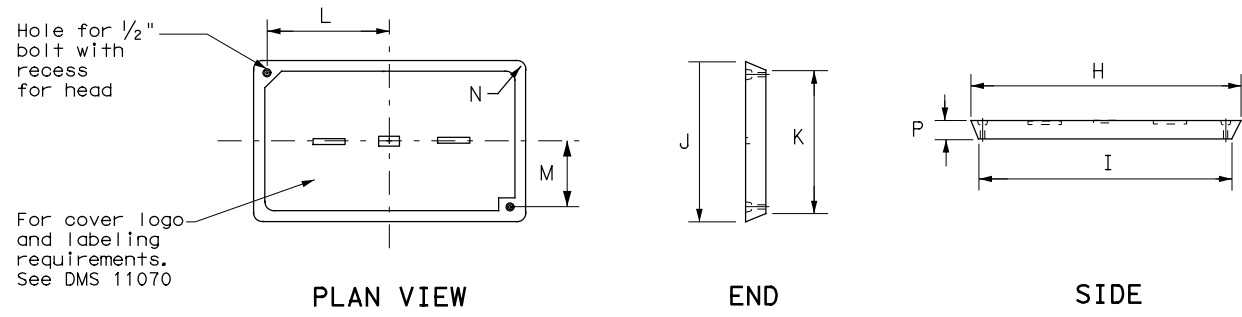

GROUND BOX COVER

GROUND BOXES

A. MATERIALS

1. Provide polymer concrete ground boxes measuring 16x30x24 in. (WxLxD) or smaller in accordance with Departmental Material Specification (DMS) 11070 "Ground Boxes" and Item 624 "Ground Boxes."
2. Provide Type A, B, C, D, and E ground boxes as shown in the plans, and as listed on the Material Producers List (MPL) on the Department web site under "Roadway Illumination and Electrical Supplies," Item 624.
3. Ensure ground box cover is correctly labeled in accordance with DMS 11070.
4. Provide larger ground boxes in accordance with Item 624 and as shown in the plans.

B. CONSTRUCTION METHODS

1. Remove all gravel and dirt from conduit. Cap all conduits prior to placing aggregate and setting ground box. Provide Grade 3 or 4 coarse aggregate as shown on Table 2 of Item 302 "Aggregates for Surface Treatments." Ensure aggregate bed is in place and at least 9 inches deep, prior to setting the ground box. Install ground box on top of aggregate.
2. Cast ground box aprons in place. Reinforcing steel may be field bent. Ensure the depth of concrete for the apron extends from finished grade to the top of the aggregate bed under the box. Ground box aprons, including concrete and reinforcing steel, are subsidiary to ground boxes when called for by descriptive code.
3. Keep bolt holes in the box clear of dirt. Bolt covers down when not working in ground boxes.
4. Install all conduits and ells in a neat and workmanlike manner. Uniformly space conduits so grounding bushings and bell end fittings can easily be installed.
5. Temporarily seal all conduits in the ground box until conductors are installed.
6. Permanently seal conduits immediately after the completion of conductor installation and pull tests. Permanently seal the ends of all conduits with duct seal, expandable foam, or other method as approved. Do not use duct tape as a permanent conduit sealant. Do not use silicone caulk as a sealant.
7. When a ground rod is present in a ground box, bond all equipment grounding conductors together and to the ground rod with listed connectors.
8. When a type B or D ground box is stacked to meet volume requirements, it is allowable to cut an appropriately sized hole for conduit entry in the side wall at least 18 inches below grade.
9. If an existing ground box in the contract has a metal cover, bond the cover to the equipment grounding conductor with a 3 ft. long stranded bonding jumper the same size as the grounding conductor. The bonding jumper is subsidiary to various bid items. Verify existing ground boxes with metal covers are shown on the plans, with notes fully describing the work required.
10. If other ground boxes with metal covers are within the project limits but are not part of the contract, the Engineer may direct the Contractor to bond the metal covers, identifying the specific boxes in writing. This work will be paid for separately.
11. Bond metal ground box covers to the grounding conductor with a tank ground type lug.

				Traffic Operations Division Standard	
<h2>ELECTRICAL DETAILS</h2> <h3>GROUND BOXES</h3> <h4>ED(4)-14</h4>					
FILE:	ed4-14.dgn	DN:	TxDOT	CK:	TxDOT
© TxDOT	October 2014	CONT:	0910	SECT:	16
REVISIONS		JOB:	180	SH:	64, Etc.
DIST:		COUNTY:		SHEET NO.:	
TYL:		SMITH, Etc.			25

ELECTRICAL SERVICES NOTES

- Provide new materials. Ensure installation and materials comply with the applicable provisions of the National Electrical Code (NEC) and National Electrical Manufacturers Association (NEMA) standards. Ensure material is Underwriters Laboratories (UL) listed. Provide and install electrical service conduits, conductors, disconnects, contactors, circuit breaker panels, and branch circuit breakers as shown on the Electrical Service Data chart in the plans. Faulty fabrication or poor workmanship in material, equipment, or installation is justification for rejection. Where manufacturers provide warranties and guarantees as a customary trade practice, furnish these to the State.
- Provide electrical services in accordance with Electrical Details standard sheets, Departmental Material Specification (DMS) 11080 "Electrical Services," DMS 11081 "Electrical Services-Type A," DMS 11082 "Electrical Services-Type C," DMS 11083 "Electrical Services-Type D," DMS 11084 "Electrical Services-Type T," DMS 11085 "Electrical Services-Pedestal (PS)", and Item 628 "Electrical Services" of the Standard Specifications. Provide electrical service types A, C, and D, as listed on the Material Producers List (MPL) on the Department web site under "Roadway Illumination and Electrical Supplies," Item 628. Provide other service types as detailed on the plans.
- Provide all work, materials, services, and any incidentals needed to install a complete electrical service as specified in the plans.
- Coordinate with the Engineer and the utility provider for metering and compliance with utility requirements. Primary line extensions, connection charges, meter charges, and other charges by the utility company to provide power to the location are paid for in accordance with Item 628. Get approval for the costs associated with these charges prior to engaging the utility company to do the work. Consult with the utility provider to determine costs and requirements, and coordinate the work as approved.
- The enclosure manufacturer will provide Master Lock Type 2 with brass tumblers keyed #2195 for all custom electrical enclosures. Installing Contractor is to provide Master Lock #2195 Type 2 with brass tumblers for "off the shelf" enclosures. Master Lock #2195 keys and locks become property of the State. Unless otherwise approved, do not energize electrical service equipment until locks are installed.
- Enclosures with external disconnects that de-energize all equipment inside the enclosure do not need a dead front trim. Protect incoming line terminations from incidental contact as required by the NEC.
- When galvanized is specified for nuts, screws, bolts or miscellaneous hardware, stainless steel may be used.
- Provide wiring and electrical components rated for 75°C. Provide red, black, and white colored XHHW service entrance conductors of minimum size 6 American Wire Gauge (AWG). Identify size 6 AWG conductors by continuous color jacket. Identify electrical conductors sized 4 AWG and larger by continuous color jacket or by colored tape. Mark at least 6 inches of the conductor's insulation with half laps of colored tape, when identifying conductors. Ensure each service entrance conductor exits through a separately bushed non-metallic opening in the weatherhead. The lengths of the conductors outside the weatherhead are to be 12 inches minimum, 18 inches maximum, or as required by utility.
- All electrical service conduit and conductors attached to the electrical service including the riser or the elbow below ground are subsidiary to the electrical service. For an underground utility feed, all service conduit and conductors after the elbow, including service conduit and conductors for the utility pole riser when furnished by the Contractor, will be paid for separately.
- Provide rigid metal conduit (RMC) for all conduits on service, except for the 1/2 in. PVC conduit containing the electrical service grounding electrode conductor. Size the service entrance conduit as shown in the plans. Ensure conduit for branch circuit entry to enclosure is the same size as that shown on the layout sheets for branch circuit conduit. Extend all rigid metal conduits a minimum of 6 inches underground and then couple to the type and schedule of the conduit shown on the layout for that particular branch circuit. Install a grounding bushing on the RMC where it terminates in the service enclosure.
- Use of liquidtight flexible metal conduit (LFMC) is allowed between the meter and service enclosure when they are mounted 90 to 180 degrees to each other. Size the LFMC the same size as service entrance conduit. LFMC must not exceed 3 feet in length. Strap LFMC within 1 foot of each end. LFMC less than 12 inches in length need not be strapped. Each end of LFMC must have a grounding bushing or be terminated with a grounding fitting. The LFMC must contain a grounded (neutral) conductor. Ensure any bend in LFMC never exceeds 180 degrees. A pull test is required on all installed conductors, with at least six inches of free conductor movement demonstrated to the satisfaction of the Engineer.
- Ensure all mounting hardware and installation details of services conform to utility company specifications.
- For all electrical service enclosures listed under Item 628 on the MPL, the UL 508 enclosure manufacturers will prepare and submit a schematic drawing unique to each service. Before shipment to the job site, place the applicable laminated schematic drawings and the laminated plan sheet showing the electrical service data chart used to build the enclosure in the enclosure's data pocket. The installing contractor will copy and laminate the actual project plan sheets detailing all equipment and branch circuits supplied by that service. The laminated plan sheets are to be placed in the service enclosure's document pocket. Reduce 11 in. x 17 in. plan sheets to 8 1/2 in. x 11 in. before laminating. If the installation differs from the plan sheets, the installing contractor is to redline plan sheets before laminating.
- When providing an "Off The Shelf" Type D or Type T service, provide laminated plan sheets detailing equipment and branch circuits supplied by that service. Reduce 11 in. x 17 in. plan sheets to 8 1/2 in. x 11 in. before laminating. Deliver these drawings before completion of the work to the Engineer, instead of placing in enclosure that has no door pocket.
- Do not install conduit in the back wall of a service enclosure where it would penetrate the equipment mounting panel inside the enclosure. Provide grounding bushings on all metal conduits, and terminate bonding jumpers to grounding bus. Grounding bushings are not required when the end of the metal conduit is fitted with a conduit sealing hub or threaded boss, such as a meter base hub.

SERVICE ASSEMBLY ENCLOSURE

- Provide threaded hub for all conduit entries into the top of enclosure.
- Type galvanized steel (GS) enclosures may be used for Type C panelboards and for Type D and T services that do not use an enclosure mounted photoce ll or lighting contactor. Provide GS enclosures in accordance with DMS 11080, 11082, 11083, and 11084.
- Provide aluminum (AL) and stainless steel (SS) enclosures for Types A, C, and D in accordance with DMS 11080, 11081, 11082, 11083, and 11084. Do not paint stainless steel.
- Provide pedestal service (PS) enclosures in accordance with ED(9) and DMS 11080 and 11085. Do not provide GS pedestal services. If GS is shown in the PS descriptive code, provide an AL enclosure.

MAIN DISCONNECT & BRANCH CIRCUIT BREAKERS

- Field drill flange-mounted remote operator handle if needed, to ensure handle is lockable in both the "On" and "Off" positions.
- When the utility company provides a transformer larger than 50 KVA, verify that the available fault current is less than the circuit breaker's ampere interrupting capacity (AIC) rating and provide documentation from the electric utility provider to the Engineer.

PHOTOELECTRIC CONTROL

- Provide photocell as listed on the MPL. Move, adjust, or shield the photocell from stray or ambient night time light to ensure proper operation. Mount photocell facing north when practical. Mount top of pole photocells as shown on Top Mounted Photocell Detail.

* ELECTRICAL SERVICE DATA												
Elec. Service ID	Plan Sheet Number	Electrical Service Description	Service Conduit *xS Size	Service Conductors No./Size	Safety Switch Amps	Main Ckt. Bkr. Pole/Amps	Two-Pole Contractor Amps	Panelbd/ Loadcenter Amp Rating	Branch Circuit ID	Branch Ckt. Bkr. Pole/Amps	Branch Circuit Amps	KVA Load
SB 183	289	ELC SRV TY A 240/480 100(SS)AL(E)SF(U)	2"	3/#2	100	2P/100	100	N/A	Lighting NB	2P/40	26	28.1
									Lighting SB	2P/40	25	
									Underpass	1P/20	15	
NB Access	30	ELC SRV TY D 120/240 060(NS)SS(E)TS(O)	1 1/4"	3/#6	N/A	2P/60		100	Sig. Controller	1P/30	23	5.3
							30		Luminaires	2P/20	9	
									CCTV	1P/20	3	
2nd & Main	58	ELC SRV TY T 120/240 000(NS)GS(N)SP(O)	1 1/4"	3/#6	N/A	N/A	N/A	70	Flashing Beacon 1	1P/20	4	1.0
									Flashing Beacon 2	1P/20	4	

* Example only, not for construction. All new electrical services must have electrical service data chart specific to that service as shown in the plans.
 ** Verify service conduit size with utility. Size may change due to utility meter requirements. Ensure conduit size meets the National Electrical Code.

EXPLANATION OF ELECTRICAL SERVICE DESCRIPTIVE CODE

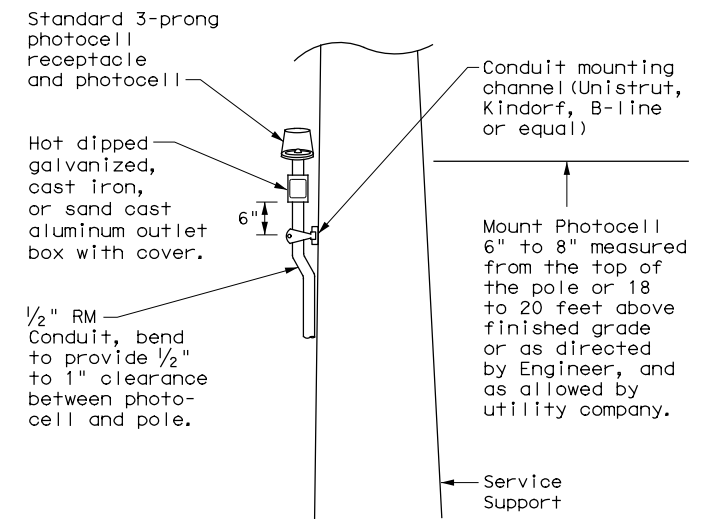
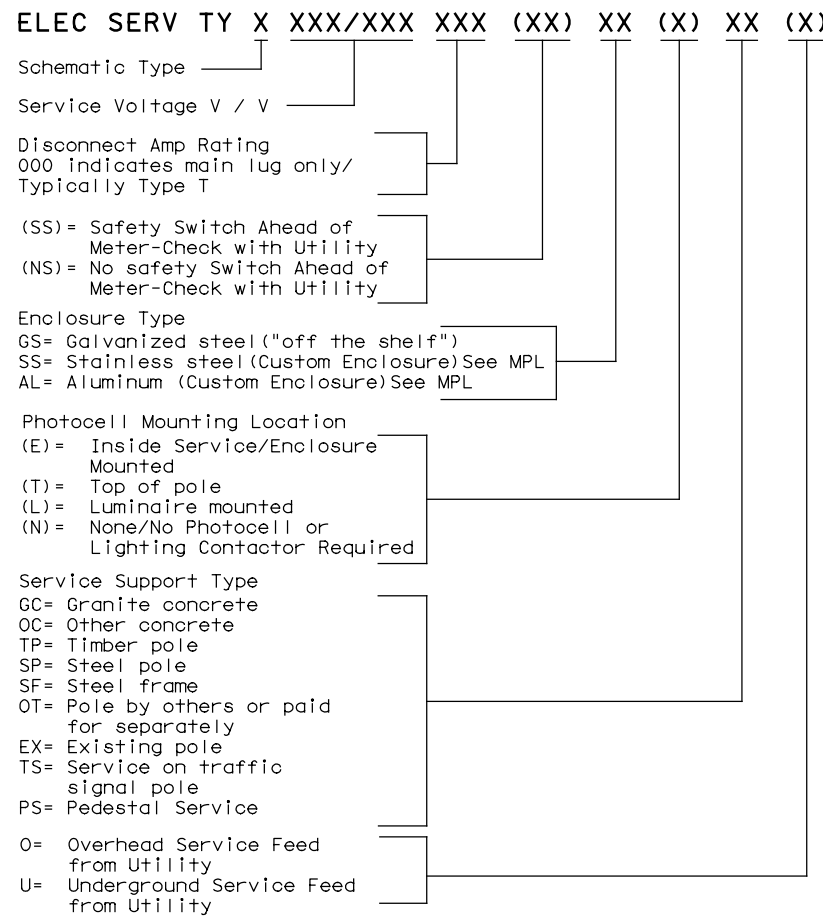

TOP MOUNTED PHOTOCELL

Install conduit strap maximum 3 feet from box. 5 foot maximum spacing between straps supporting conduit.

Texas Department of Transportation Traffic Operations Division Standard

ELECTRICAL DETAILS SERVICE NOTES & DATA

ED(5) - 14

FILE: ed5-14.dgn	DN: TxDOT	CK: TxDOT	DW: TxDOT	CK: TxDOT
© TxDOT October 2014	CONT	SECT	JOB	HIGHWAY
REVISIONS	091016	180	SH 64, Etc.	
	DIST	COUNTY	SHEET NO.	
	TYL	SMITH, Etc.	26	

DATE: 5/16/2024 9:32:42 AM
 FILE: c:\pw-InfraTech\In.Zhang\dms47076\ed5-14 (1).dgn
 The use of this standard is governed by the "Texas Engineering Practice Act". No warranty of any kind is made by TxDOT for any purpose whatsoever. TxDOT assumes no responsibility for the conversion of this standard to other formats or for incorrect results or damages resulting from its use.

DISCLAIMER: The use of this standard is governed by the "Texas Engineering Practice Act". No warranty of any kind is made by TxDOT for any purpose whatsoever. TxDOT assumes no responsibility for the conversion of this standard to other formats or for incorrect results or damages resulting from its use.

DATE: 5/16/2024 9:32:46 AM
 FILE: c:\pw-InfraTech\in.zhang\dms47076\ed6-14 (1).dgn

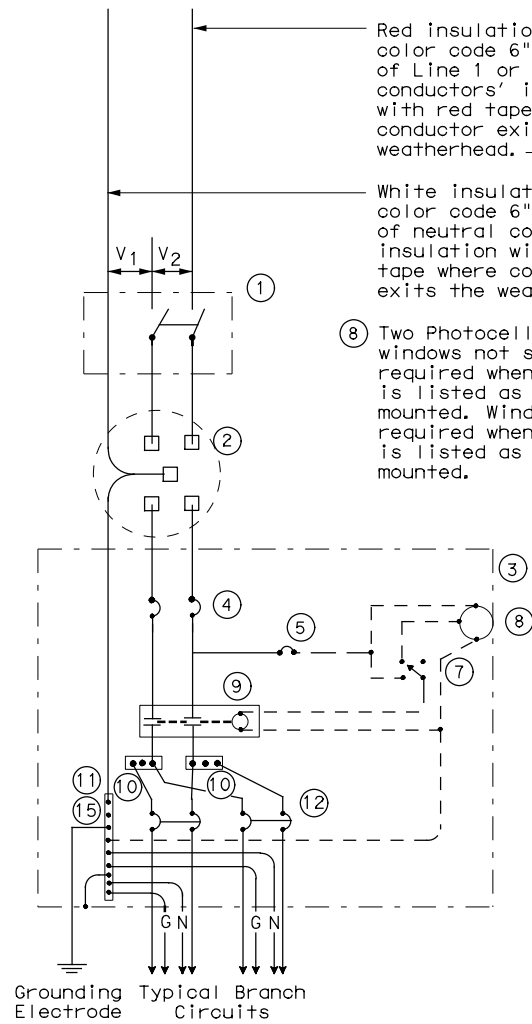

**SCHEMATIC TYPE A
THREE WIRE**

Red insulation or color code 6" length of Line 1 or Line 2 conductors' insulation with red tape where conductor exits the weatherhead.

White insulation or color code 6" length of neutral conductors' insulation with white tape where conductor exits the weatherhead.

8 Two Photocell viewing windows not shown but required when photocell is listed as enclosure mounted. Windows not required when photocell is listed as pole top mounted.

Do not bond this bus to the enclosure

WIRING LEGEND	
————	Power Wiring
-----	Control Wiring
—N—	Neutral Conductor
—G—	Equipment grounding conductor-always required

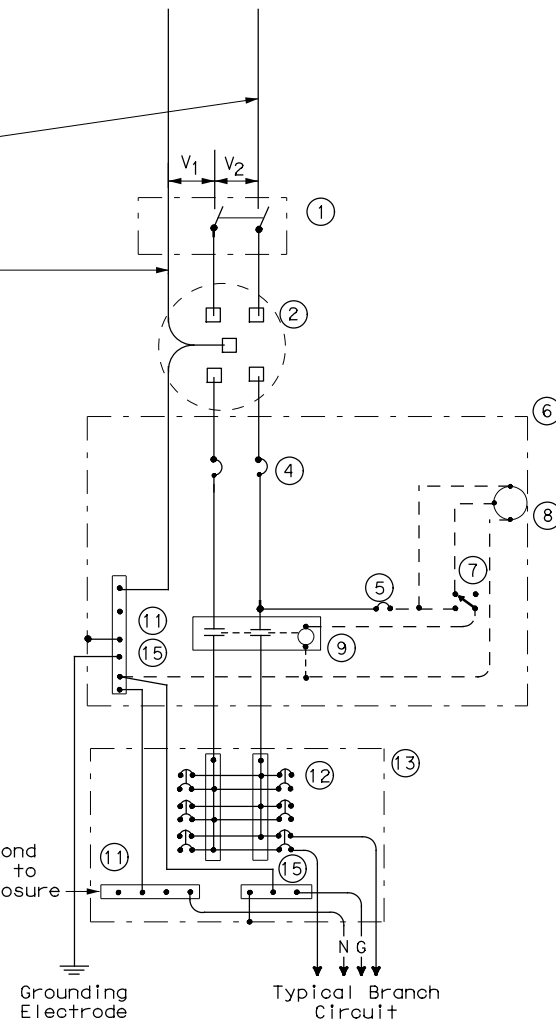

**SCHEMATIC TYPE C
THREE WIRE**

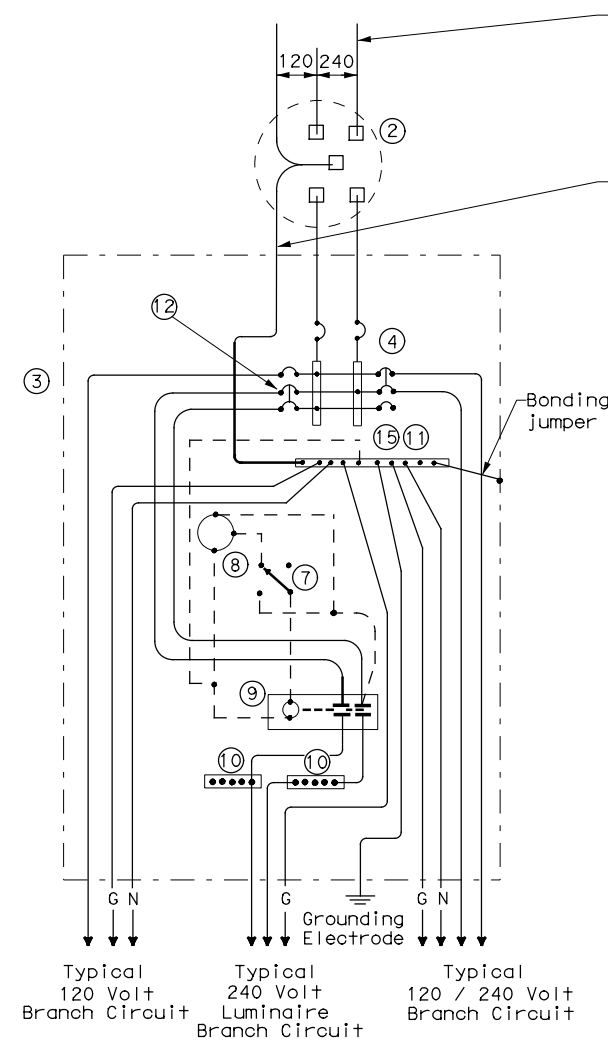

**SCHEMATIC TYPE D - CUSTOM
120/240 VOLTS - THREE WIRE**

Red insulation or color code 6" length of Line 1 or Line 2 conductors' insulation with red tape where conductor exits the weatherhead.

White insulation or color code 6" length of neutral conductors' insulation with white tape where conductor exits the weatherhead.

Bonding Jumper

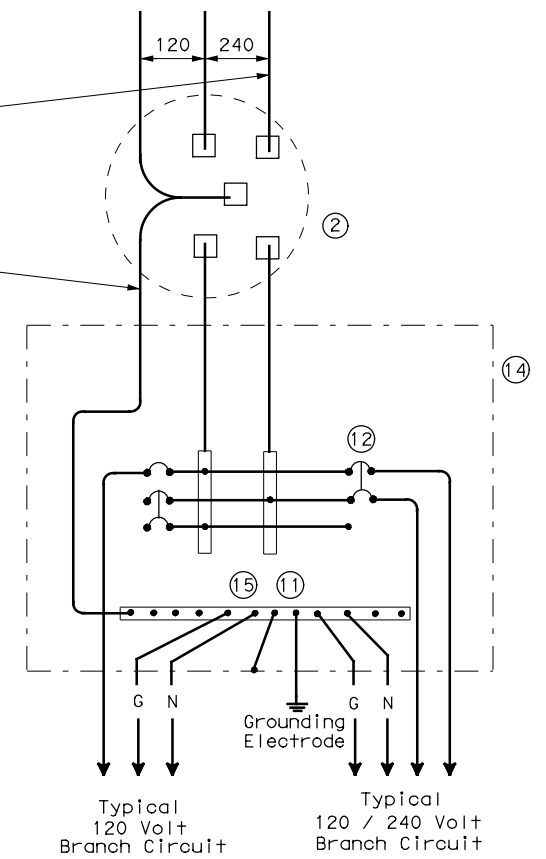

**SCHEMATIC TYPE T
120/240 VOLTS - THREE WIRE**
 Galvanized steel-"Buy Off The Shelf" only. When required install photocell top of the pole or on luminaire only, no lighting contractor will be installed.

SCHEMATIC LEGEND	
1	Safety Switch (when required)
2	Meter (when required-verify with electric utility provider)
3	Service Assembly Enclosure
4	Main Disconnect Breaker (See Electrical Service Data)
5	Circuit Breaker, 15 Amp (Control Circuit)
6	Auxiliary Enclosure
7	Control Station ("H-O-A" Switch)
8	Photo Electric Control (enclosure-mounted shown)
9	Lighting Contactor
10	Power Distribution Terminal Blocks
11	Neutral Bus
12	Branch Circuit Breaker (See Electrical Service Data)
13	Separate Circuit Breaker Panelboard
14	Load Center
15	Ground Bus

				Traffic Operations Division Standard	
ELECTRICAL DETAILS SERVICE ENCLOSURE AND NOTES					
ED (6) - 14					
FILE: ed6-14.dgn	DN: TxDOT	CK: TxDOT	DW: TxDOT	CK: TxDOT	
© TxDOT October 2014	CONT	SECT	JOB	HIGHWAY	
REVISIONS		0910	16	180	SH 64, Etc.
	DIST	COUNTY	SHEET NO.		
	TYL	SMITH, Etc.	27		

DISCLAIMER: The use of this standard is governed by the "Texas Engineering Practice Act". No warranty of any kind is made by TxDOT for any purpose whatsoever. TxDOT assumes no responsibility for the conversion of this standard to other formats or for incorrect results or damages resulting from its use.

DATE: 5/16/2024 9:32:49 AM
 FILE: c:\pw-inf\fractech\in.zhang\dms47076\ed7-14 (1).dgn

SUPPORT TYPE STEEL POLE (SP) AND STEEL FRAME (SF)

- Provide steel pole and steel frame supports as per TxDOT Departmental Material Specification (DMS)11080 "Electrical Services." Mount all equipment and conduit on 12 gauge galvanized steel or stainless steel channel strut, 1 1/2 in. or 1 3/8 in. wide by 1 in. up to 3 3/4 in. deep Unistrut, Kindorf, B-line or equal. Bolt or weld all channel and hardware to vertical members as approved. Do not stack channel. File smooth and paint field cut ends of all channel with zinc-rich paint before installing.
- Provide poles for overhead service with an eyebolt or similar fitting for attachment of the service drop to the pole in conformance with the electric utility provider's specifications.
- Provide and install galvanized 3/4 in. x 18 in. x 4 in. (dia. x length x hook length) anchor bolts for underground service supports. Provide and install galvanized 3/4 in. x 56 in. x 4 in. anchor bolts for overhead service supports. Ensure anchor bolts have 3 in of thread, with 3 1/4 in. to 3 1/2 in. of the exposed anchor bolt projecting above finished foundation. Provide and install leveling nuts for all anchor bolts.
- Bond one of the anchor bolts to the rebar cage with 6 AWG bare stranded copper conductor. Use listed mechanical connectors rated for embedment in concrete. See Inset B.
- Furnish and install rigid metallic ells in all steel pole and steel frame foundations for all conduits entering the service from underground.
- Use class C concrete for foundations. Ensure reinforcing steel is Grade 60 with 3" of unobstructed concrete cover.
- Drill and tap steel poles and frames for 1/2 in. X 13 UNC tank ground fitting. For steel pole service supports, provide and install tank ground fitting 4 in. to 6 in. below electrical service enclosure. Provide properly sized hole through the bottom of the enclosure for the service grounding electrode conductor. Ensure electrical service grounding electrode conductor is as short and straight as possible from the enclosure to the tank ground fitting. For steel frame service supports, provide and install tank ground fitting on steel frame post. Install service grounding electrode conductor in a non-metallic conduit or tubing from the enclosure to the steel frame post. Connect electrical service grounding electrode conductor to the tank ground fitting. See steel frame and steel pole details and Inset A for more information. Size service entrance conduit and branch circuit conduit as shown in the plans. For underground conduit runs from the electrical service, extend RMC from the service enclosure to an RMC elbow, and then connect the schedule type and size of conduit shown in the plans. Provide and install grounding bushings where RMC terminates in the enclosure. Grounding bushings are not required when RMC is fitted into a sealing hub or threaded boss.
- If Steel pole or frame is painted, bond each separate painted piece with a bonding jumper attached to a tapped hole.
- Provide 1/4" - 20 machine screws for bonding. Do not use sheet metal screws. Remove all non-conductive material at contact points. Terminate bonding jumpers with listed devices. Install minimum size 6 AWG stranded copper bonding jumpers. Make up all threaded bonding connections wrench tight.
- Avoid contact of the service drop and service entrance conductors with the metal pole to prevent abrasion of the insulated conductors.
- Shop drawings are not required for service support structure unless specifically stated elsewhere or directed by the Engineer.

White insulation or color code 6" of neutral conductor's insulation with white tape where conductor exits weatherhead.

Red insulation or color code 6" length of Line 1 or Line 2 conductor's insulation with red tape where conductor exits the weatherhead. Conductor slack length, 12" min., 18" max.

20' measured from grade. Circumstances may require the electrical service support to be taller than the 20" shown, check with utility before installing.

Point of attachment of service drop to be below weatherhead.
 Conduit support spacing, 3' max from the ends, and 5' in between unless otherwise called for by the utility.

Top of weatherhead to be 2" to 6", 4" typical below the top of pole.
 White insulation or color code 6" of neutral conductor's insulation with white tape where conductor exits weatherhead.
 Red insulation or color code 6" length of Line 1 or Line 2 conductor's insulation with red tape where conductor exits the weatherhead. Conductor slack length, 12" min., 18" max.

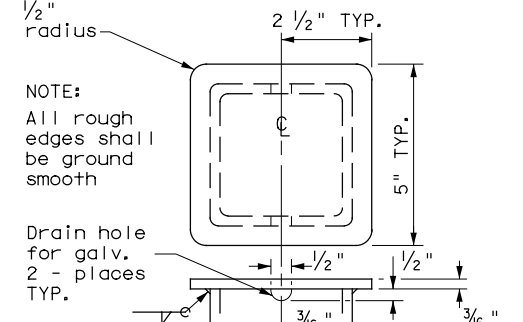

POLE TOP PLATE

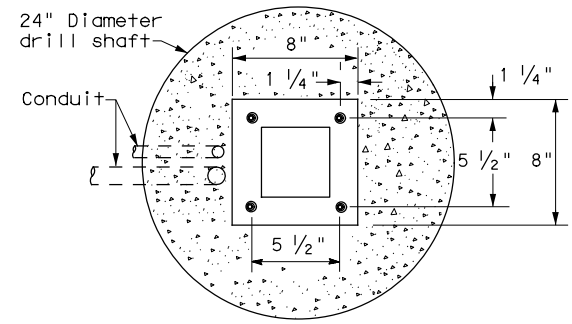

BASE PLATE DETAIL

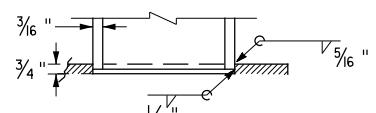

BOTTOM OF POLE

SERVICE SUPPORT TYPE SF & SP

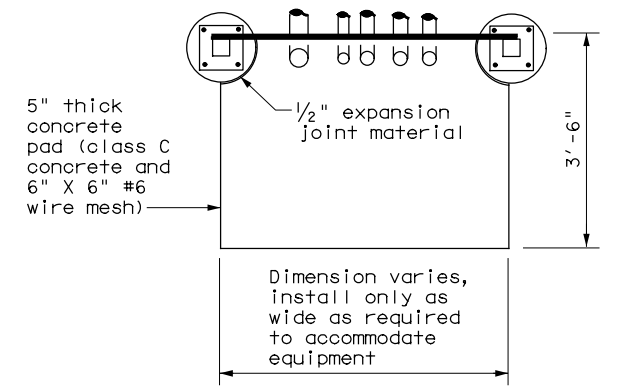

TOP VIEW

SERVICE SUPPORT TY SF (O) & SF (U)

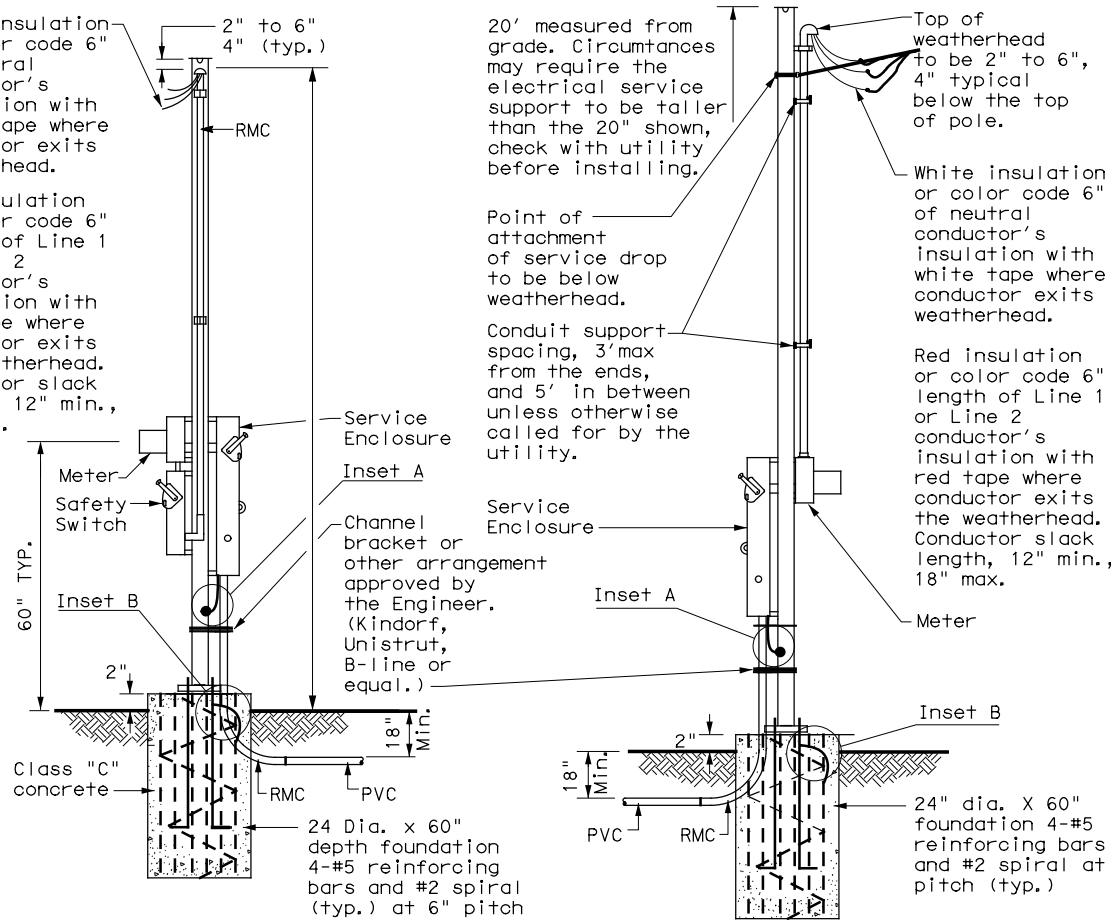

SERVICE SUPPORT TYPE SP (O) - OVERHEAD SERVICE

Drill, tap, and thread 1/2" X 13 UNC. Install tank ground fitting, connect electrical service grounding electrode conductor. See Note 7.

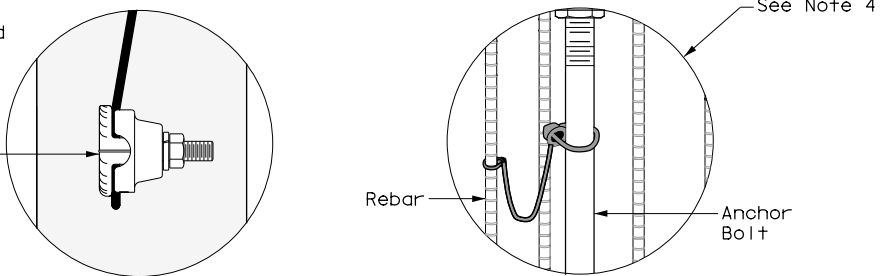

FRONT VIEW INSET A

INSET B

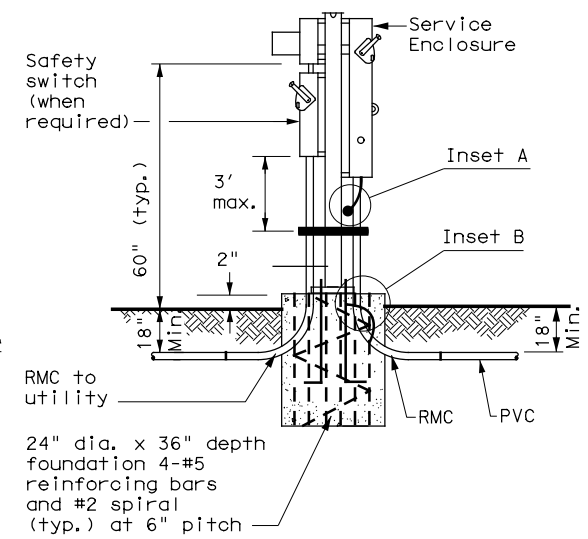

SERVICE SUPPORT TYPE SP (U) - UNDERGROUND SERVICE

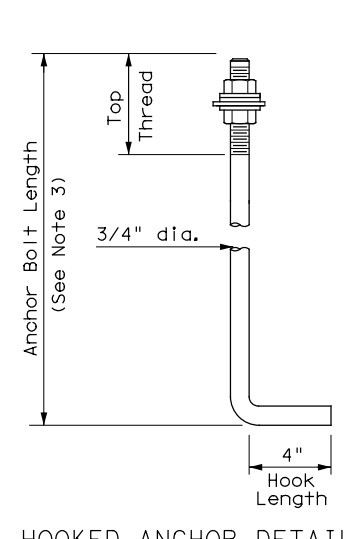

HOOKED ANCHOR DETAIL

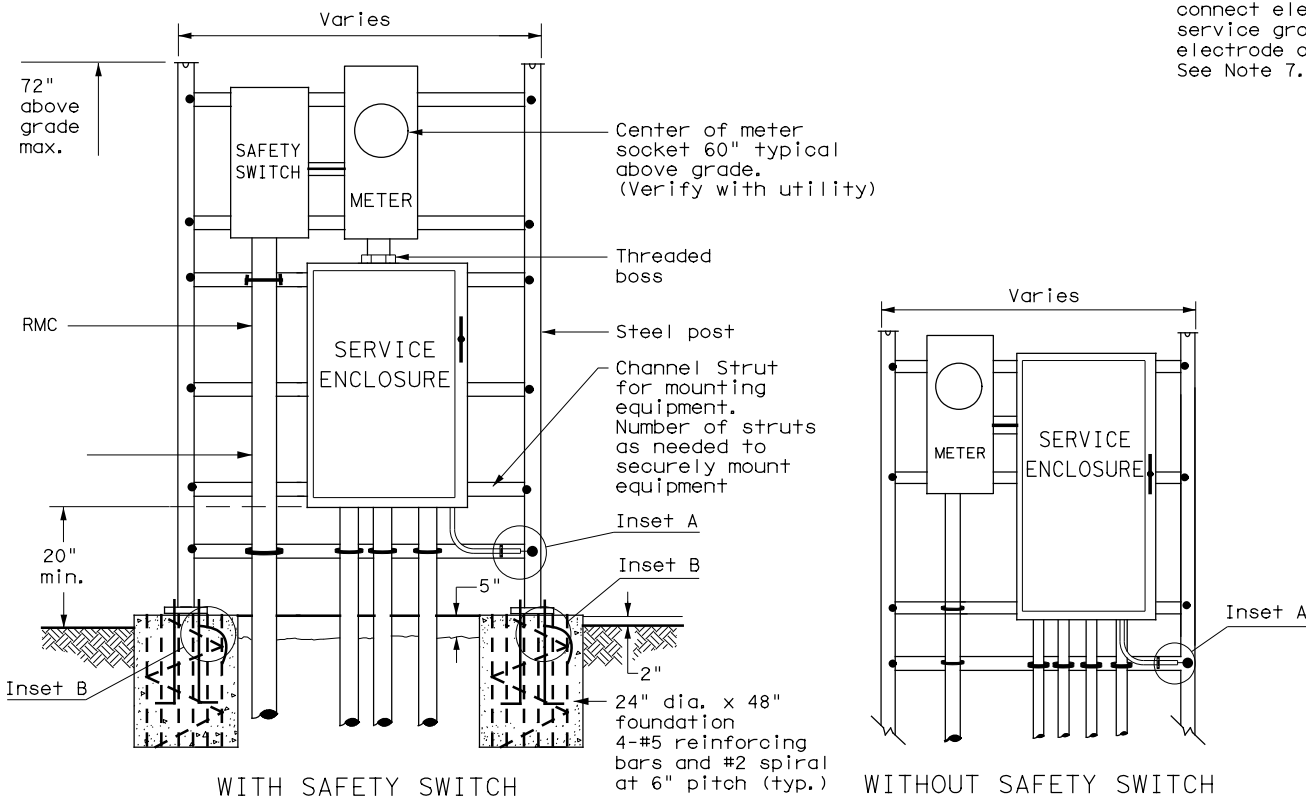

SERVICE SUPPORT TYPE SF (U) - UNDERGROUND SERVICE

ELECTRICAL DETAILS SERVICE SUPPORT TYPES SF & SP ED(7)-14

FILE: ed7-14.dgn	DN: TxDOT	CK: TxDOT	DW: TxDOT	CK: TxDOT
©TxDOT October 2014	CONT	SECT	JOB	HIGHWAY
REVISIONS	0910	16	180	SH 64, Etc.
DIST	COUNTY	SHEET NO.		
TYL	SMITH, Etc.	28		

DISCLAIMER: The use of this standard is governed by the "Texas Engineering Practice Act". No warranty of any kind is made by TxDOT for any purpose whatsoever. TxDOT assumes no responsibility for the conversion of this standard to other formats or for incorrect results or damages resulting from its use.

DATE: 5/16/2024 9:32:53 AM
 FILE: c:\pw-InfraTech\in.zhang\dms47076\ed11-14.dgn

DUCT CABLE & HDPE CONDUIT NOTES

1. Provide duct cable in accordance with Departmental Material Specification (DMS) 11060 "Duct Cable" and Item 622 "Duct Cable." Provide duct cable as listed on the Material Producer List (MPL) on the Department web site under "Roadway Illumination and Electrical Supplies" Item 622.
2. Provide High-Density Polyethylene (HDPE) conduit in accordance with DMS 11060 and Item 618, "Conduit." Provide HDPE as listed on the MPL on the Department web site under "Roadway Illumination and Electrical Supplies," Item 618.
3. Supply duct cable with a minimum 2 in. diameter, unless otherwise shown in the plans. Provide duct cable and HDPE conduit as shown by descriptive code or on the plans. Bend duct cable and HDPE conduit as recommended by the manufacturer, with a minimum bending radius of 26 in. for 2 in. duct. Follow manufacturers' recommendations when handling duct cable and HDPE conduit reels and during installation of duct cable and HDPE conduit.
4. Do not splice conductors within duct cable or HDPE conduit. Couple duct cable and HDPE entering a ground box or foundation to a PVC elbow. When galvanized steel RMC elbows are called for in the plans and any portion of the RMC elbow is buried less than 18" from possible contact, ground the RMC elbow.
5. Furnish and install duct cable with factory installed conductors, sized as shown in the plans and as required by the National Electrical Code (NEC). The NEC contains specific requirements for duct cable in Article, "Nonmetallic Underground Conduit with Conductors: Type NUCC."
6. When conduit casing is called for in the plans, extend duct cable or HDPE conduit through the conduit casing in one continuous length without connection to the casing.
7. Seal the ends of duct cable or HDPE conduit with duct seal, expandable foam, or other approved method after completing the pull tests required by Item 622.
8. Provide minimum cover of 24 in. under roadways, 18 in. in other locations, or as shown on the plans.
9. Furnish and install listed fittings to couple duct cable or HDPE conduit to other types of conduit. Duct cable and HDPE conduit may be field-threaded and spliced with PVC or RMC threaded couplings; connected with listed tie-wrap fittings; connected using listed coupling made of HDPE with stainless steel external banding clamps and locking rings; connected with approved electrofusion conduit couplings; or connected using an approved chemical fusion method using an epoxy or adhesive specifically designed for HDPE couplings and connectors all installed in accordance with their manufacturer's instructions. Do not use PVC glue on HDPE. Do not use water pipe fittings, or connect conduit with heat shrink tubing.

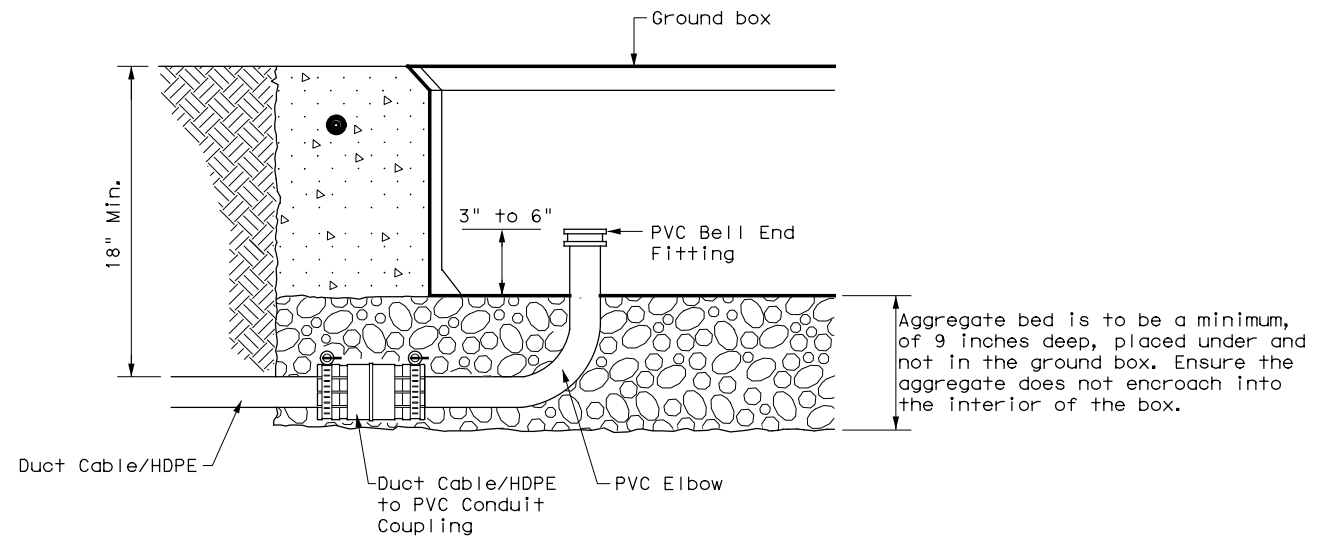

DUCT CABLE/HDPE AT GROUND BOX

When the upper end of an RMC EII does not enter the ground box, it may be extended with a SCH-40 PVC conduit nipple and bell end, provided there is a minimum of 18" of cover over all parts of the elbow. If not, a rigid extension and ground bushing is required.

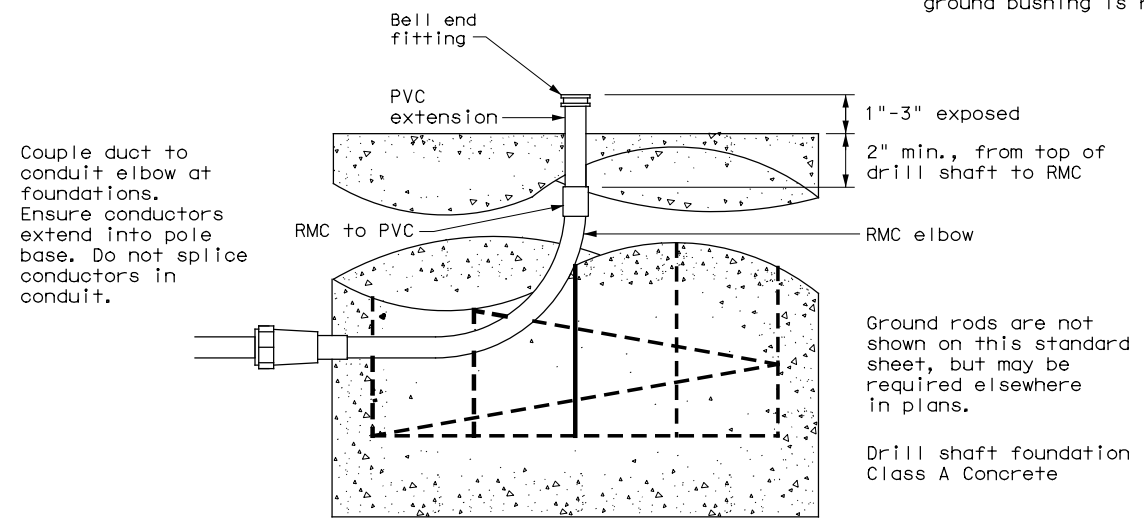

DUCT CABLE / HDPE AT FOUNDATION

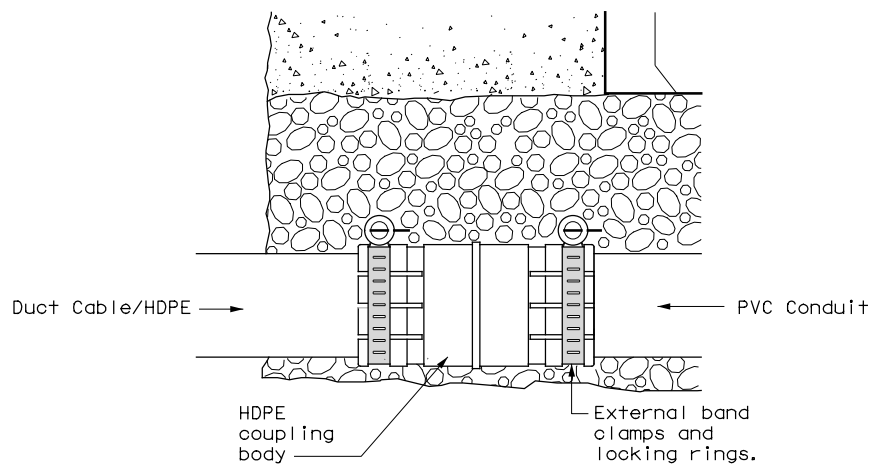

DUCT CABLE/HDPE TO PVC

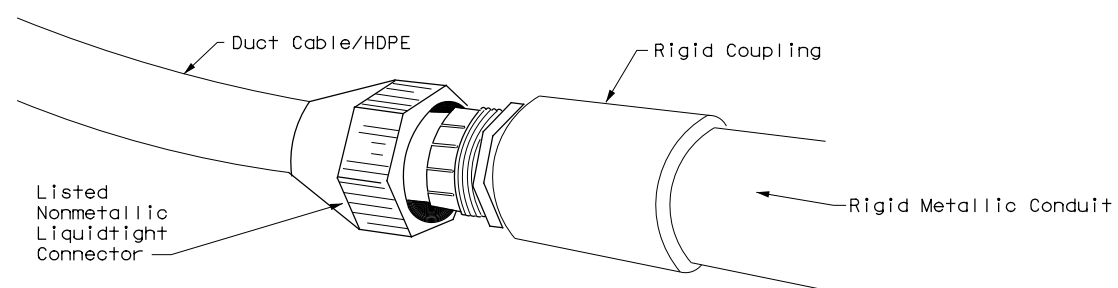

DUCT CABLE/HDPE TO RMC

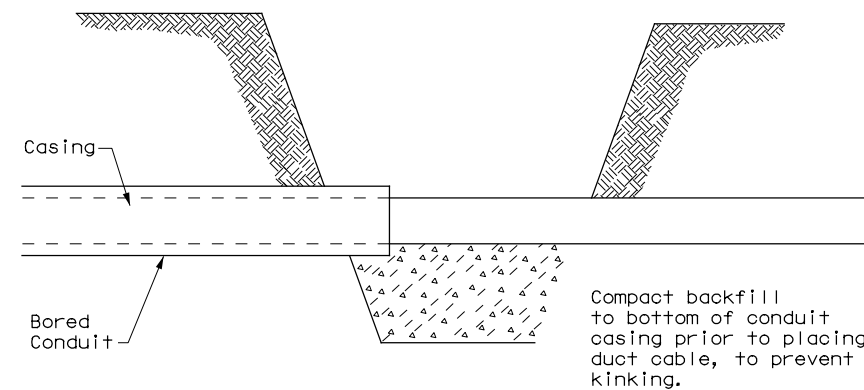

BORE PIT DETAIL

		Traffic Operations Division Standard	
ELECTRICAL DETAILS DUCT CABLE/ HDPE CONDUIT			
ED(11)-14			
FILE: ed11-14.dgn	DN: TxDOT	CK: TxDOT	DW: TxDOT
©TxDOT October 2014	CONT: 0910	SECT: 16	JOB: 180
REVISIONS		SH: 64	ETC: Etc.
DIST: TYL	COUNTY: SMITH, Etc.	SHEET NO. 29	

ROADWAY ILLUMINATION ASSEMBLY NOTES

DISCLAIMER: The use of this standard is governed by the "Texas Engineering Practice Act". No warranty of any kind is made by TxDOT for any purpose whatsoever. TxDOT assumes no responsibility for the conversion of this standard to other formats or for incorrect results or damages resulting from its use.

DATE: 5/16/2024 9:32:56 AM
FILE: c:\pw-InfraTech\In.Zhang\dms47076\rid1-20 (1).dgn

1. Details apply to roadway lighting installations bid or referenced under Item 610, "Roadway Illumination Assemblies." Provide, furnish, and install all other materials not shown on the plans which may be necessary for complete and proper construction. Where manufacturers provide warranties or guarantees as a customary trade practice, furnish to the State such warranties or guarantees.
2. The locations of poles and fixtures may be shifted by the Engineer to accommodate local conditions. Install or remove poles and luminaires located near overhead electrical lines using established industry and utility safety practices and in accordance with laws governing such work. Consult with the appropriate utility company prior to beginning such work.
3. Provide new and unused materials. Ensure that all materials and installations comply with the applicable articles of the National Electrical Code (NEC), TxDOT standards and specifications, National Electrical Manufacturers Association (NEMA), and are listed by Underwriters Laboratories (UL) or a Nationally Recognized Testing Lab (NRTL). NRTLs such as Canadian Standard Association, Intertek Testing Services NA Inc., or FM Approvals LLC can be considered equivalent to UL. Faulty fabrication or poor workmanship in any material, equipment, or installation is justification for rejection.
4. Provide Roadway Illumination Light Fixtures as per TxDOT Departmental Material Specification (DMS) 11010, Item 610, and as shown on the Material Producers List (MPL) for Roadway Illumination and Electrical Supplies.
5. Fabricate steel roadway illumination poles in accordance with Roadway Illumination Poles (RIP) standards and Item 610. Poles fabricated according to RIP standards do not require shop drawing submittals.
 - a. Alternate designs to RIP standards or the use of aluminum to fabricate poles will require the submission of shop drawings electronically. For instructions on submitting shop drawings electronically see "Guide to Electronic Shop Drawing Submittal" on the TxDOT web site.
 - b. Limitations on use of the RIP standard: The RIP standard details were developed for installations in locations where the 3-second gust basic maximum wind speed is 110 mph, and where the elevation of the base of the pole is less than (i.e. not more than) 25' above the elevation of the surrounding terrain, in accordance with the "AASHTO Standard Specifications for Structural Supports for Highway Signs, Luminaires and Traffic Signals," 6th Edition (2013) of the AASHTO Design Specifications. For poles to be installed in regions where the maximum basic wind speed exceeds 110 mph or to be mounted more than 25' above the surrounding terrain, provide poles meeting the following requirements:
 - i. Submittals. Following the electronic shop drawing submittal process (see Guide to Electronic Shop Drawing Submittal on the TxDOT web site), submit to the Engineer for approval fabrication drawings and calculations for the poles, sealed by a Texas licensed professional engineer (P.E.).
 - ii. Luminaire Structural Support Requirements. Provide light poles, arms, and anchor bolt assemblies with a 25 year design life to safely resist dead loads, ice loads and the required basic wind speeds at the location of installation in accordance with the 6th edition (2013) of the AASHTO Design Specifications. For transformer base poles, include transformer base and connecting hardware in calculations and shop drawing submittals. Structurally test all transformer bases to resist the theoretical plastic moment capacity of the pole. Submit certification of the plastic moment load test and FHWA breakaway requirement test of the model of base being furnished with the shop drawings. Show breakaway base model number, manufacturer's name, and logo on shop drawings. Include on manufacturer's shop drawings the ASTM designations for all materials to be used.
6. For both transformer and shoe-base type illumination poles, provide and install double-pole breakaway fuse holders as specified by DMS-11040. Breakaway fuse holders are listed on the MPL for Roadway Illumination and Electrical Supplies under Items 610 & 620. Provide 10 amp time delay fuses for breakaway connectors in light poles, or inside the light fixture for underpass luminaires. In each pole, connect luminaires to the breakaway connector with continuous stranded 12 AWG copper conductors as listed on the MPL. Bond all equipment grounding conductors together and to the ground lug in the transformer base or hand hole.
7. Tighten anchor bolts for shoe base, concrete traffic barrier base, and bridge mount roadway illumination poles, in accordance with Item 449.
8. Install T-Base with following procedure:
 - a. Anchor Bolt Tightening.
 - i. Coat the threads of the anchor bolts with electrically conductive lubricant.
 - ii. Place the T-base over the anchor bolts. Foundation must be level and flat. The maximum permissible gap under any one corner of the t-base is 1/8" before nuts are tightened.
 - iii. Coat the bearing surfaces of the nuts and washers with electrically conductive lubricant. Install (1) 1/2" hold down washer, (1) lock washer, and (1) nut on each anchor bolt. Turn the nuts onto the bolts so that each is hand-tight against the washer.
 - iv. Using a torque wrench, tighten each nut to 150 ft-lb. Uniform contact is required between the foundation and the T-base in the corner regions of the T-base, and all corner gaps must be closed after applying torque. If a gap still exists after torquing to 150 ft-lbs, continue torquing each bolt incrementally until gap is closed or maximum allowable torque of 250 ft. pound is reached, whichever comes first. If 250 ft-lbs is not enough to close the gap the foundation must be leveled. Gaps along the straight sides of the T-bases and the foundation are permissible. Ensure that no high point of contact occurs between the straight sides of the T-base and the foundation.
 - v. Check top of T-base for level. If not level then foundation must be leveled.
 - b. Top Bolt Procedure
 - i. Erect pole over T-base with crane. Coat bolts, nuts, washers, and lock washers with electrically conductive lubricant.

- ii. Install bolts and 1/2" connecting washers from the inside of the T-base, thread up through the pole base. Install flat washers, lock washers and nuts snug tight according to Item 447, "Structural Bolting."
- iii. Tighten each nut to 150 ft-lb. using a torque wrench.
- c. Level and Plumb
 - i. Ensure pole is plumb and mast arm is perpendicular to the roadway according to plans to within 5 degrees.
9. Construct luminaire pole foundations in accordance with Item 416, "Drilled Shaft Foundations," and TxDOT standard sheet RID(2).
10. Provide and install underpass luminaires in accordance with Item 610, DMS-11010, and TxDOT standard sheet RID(3). Typical luminaire size for underpass luminaires is 150W HPS or 150W EQ LED.
11. Mount luminaires on arms level as shown by the luminaire level indicator.
12. Orient luminaires perpendicular to the roadway intended to be lit unless otherwise shown on the plans.

Wiring Diagram Notes:

- ① Use 1/2 in.-13 UNC threaded, copper or tin-plated copper, pole bonding connector, sized appropriately for conductors, bonded to T-base, or use ground lug in handhole as available.
- ② Use pre-qualified two-pole breakaway connectors for all luminaire pole installations. For luminaires fed by a circuit with a neutral conductor, use double pole breakaway connectors with the neutral side unfused and marked white.
- ③ Split Bolt or other connector.

Decorative LED Lighting Notes:

1. LED Drivers in Remote Outdoor enclosures (for drivers that do not include an enclosure as part of a factory assembly):
 - a. Provide NEMA 3R outdoor enclosure or as approved.
 - b. Install enclosure at least 12" above ground or other horizontal surface. Mount vertically or on ceiling, and avoid direct sun where possible.
 - c. Install drivers with at least 2 inches of space from enclosure walls.
 - d. For multiple drivers in an enclosure, provide at least 4 inches side to side and 1 inch end to end from other drivers or electronic equipment
 - e. For drivers mounted on back wall of enclosure, mount enclosure on 1 5/8" strut or other standoff to dissipate heat, or mount driver to side of the enclosure or to the metal cover.
 - f. Provide remote drivers with a maximum of 100 watts
 - g. Provide drivers with documentation of 100,000 hr lifetime at Tcase of 65C or higher.

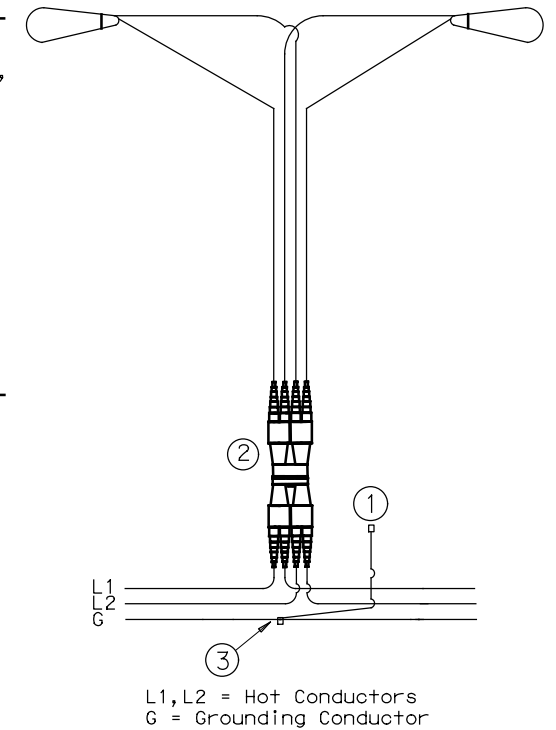

TYPICAL WIRING DIAGRAM

LUMINAIRES SERVED AT 480V ON 240/480 VOLT SERVICE OR LUMINAIRES SERVED AT 240V FOR 120/240 VOLT SERVICE.

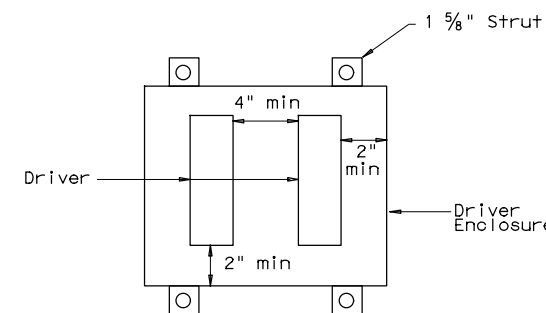

Driver Spacing In Remote Enclosure

				Traffic Safety Division Standard	
<h1>ROADWAY ILLUMINATION DETAILS</h1> <h2>RID(1)-20</h2>					
FILE:	rid1-20.dgn	DN:	CK:	DW:	CK:
© TxDOT	January 2007	CONT	SECT	JOB	HIGHWAY
REVISIONS		0910	16	180	SH 64, Etc.
7-17		DIST	COUNTY		SHEET NO.
12-20		TYL	SMITH, Etc.		30

DISCLAIMER: The use of this standard is governed by the "Texas Engineering Practice Act". No warranty of any kind is made by TxDOT for any purpose whatsoever. TxDOT assumes no responsibility for the conversion of this standard to other formats or for incorrect results or damages resulting from its use.

DATE: 5/16/2024 9:33:00 AM
 FILE: c:\pw-InfraTech\in.zhang\dms47076\rid2-20 (2).dgn

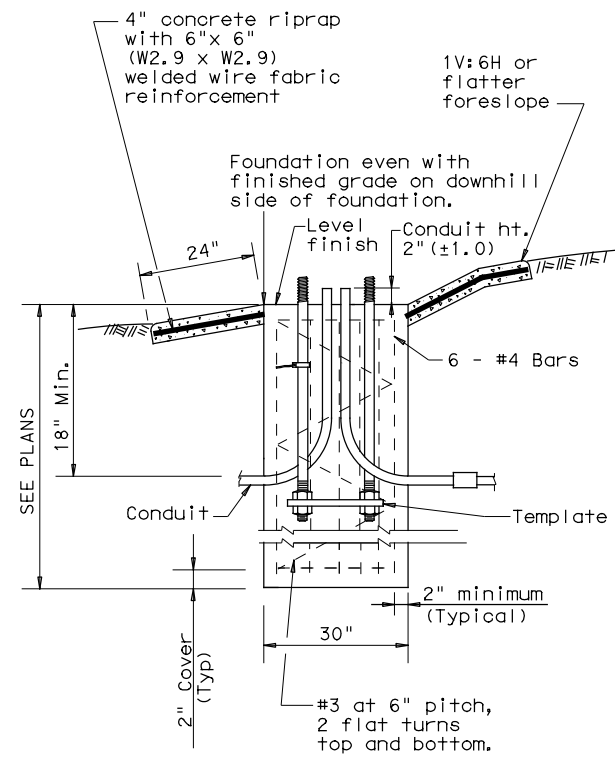

SECTION A-A
SHOWING SLOPED GRADE

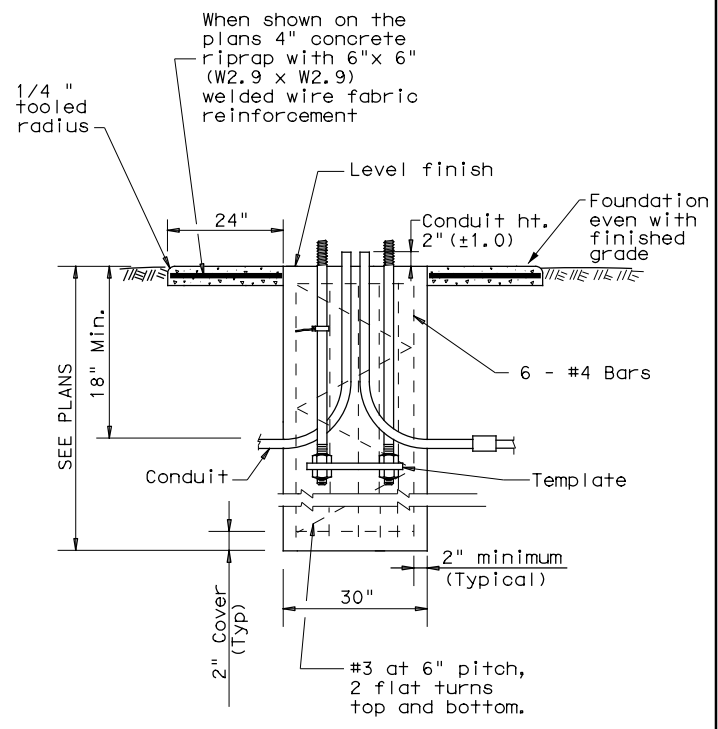

SECTION A-A
SHOWING CONSTANT GRADE

TABLE 1

ANCHOR BOLTS

POLE MOUNTING HEIGHT	BOLT CIRCLE		ANCHOR BOLT SIZE
	Shoe Base	T-Base	
<40 ft.	13 in.	14 in.	1 in. x 30 in.
40-50 ft.	15 in.	17 1/4 in.	1 1/4 in. x 30 in.

TABLE 2

RECOMMENDED FOUNDATION LENGTHS
(See note 1)

MOUNTING HEIGHT	TEXAS CONE PENETROMETER N Blows/ft		
	10	15	40
≤20 ft.	6'	6'	6'
>20 ft. to 30 ft.	8'	6'	6'
>30 ft. to 40 ft.	8'	8'	6'
>40 ft. to 50 ft.	10'	8'	6'

TABLE 3

PAY QUANTITY OF RIPRAP PER FOUNDATION
(Install only when shown on the plans)

Foundation Diameter	RIPRAP DIAMETER	RIPRAP (CONC) (CL B)
30 in.	78 in.	0.35 CY

GENERAL NOTES:

- "Recommended Foundation Lengths" table is for information purposes only. Foundation lengths shall be as shown on the plans, or as directed by the Engineer. Foundations will be paid for under Item 416, "Drilled Shaft Foundations," unless otherwise shown on the plans.
- Erect roadway illumination assembly poles plumb and true. Form and level the top 6" of the foundation so the pole will be plumb. Use leveling nuts to plumb shoe base poles. Do not use shims or leveling nuts under transformer bases. Do not grout between baseplate and the foundation.
- Ensure Class 2A and 2B fit for anchor bolts and nuts. Tap and chase nuts after galvanizing. Anchor bolt body with rolled threads need not be full size.
- Use appropriate class of concrete as specified in Items 416 and 432. Concrete for riprap may be upgraded to Class C at no extra cost to the Department.
- Place riprap around the foundation when called for elsewhere in the plans. Riprap will be paid for under Item 432.
- Locate breakaway roadway illumination assemblies as shown in the placement table, unless otherwise dimensioned on the plans. Protect non-breakaway illumination assemblies from vehicular impact (i.e. 2.5 ft. behind guard rail or mounted on traffic barrier), or located outside the clear zone, except that 2.5 ft. from curb face is minimum desired for light poles on city streets, 45 mph or less. See Roadway Design Manual for further information.
- Use 4 hold down and 4 connecting washers on transformer base poles as recommended by the manufacturer and supplied with base.
- Install a minimum of 2 conduits in each foundation. See lighting layout sheets for locations of foundations with more than 2 conduits. Cap unused conduits in foundations on both ends.
- Conduit location in foundations is critical for breakaway devices. Place conduits 2 in. apart on centerline as shown.
- Bond anchor bolt to rebar cage with #6 bare stranded copper conductor. Use listed mechanical connectors rated for embedment in concrete. The bonded steel in the foundation creates a concrete encased grounding electrode which replaces the ground rod.
- Grade earthwork around T-base foundations even with the finished grade as shown in Section A-A to ensure proper function of the breakaway device. Use riprap on T-base foundations that are located on sloped grades, and as shown on the plans for level grades.

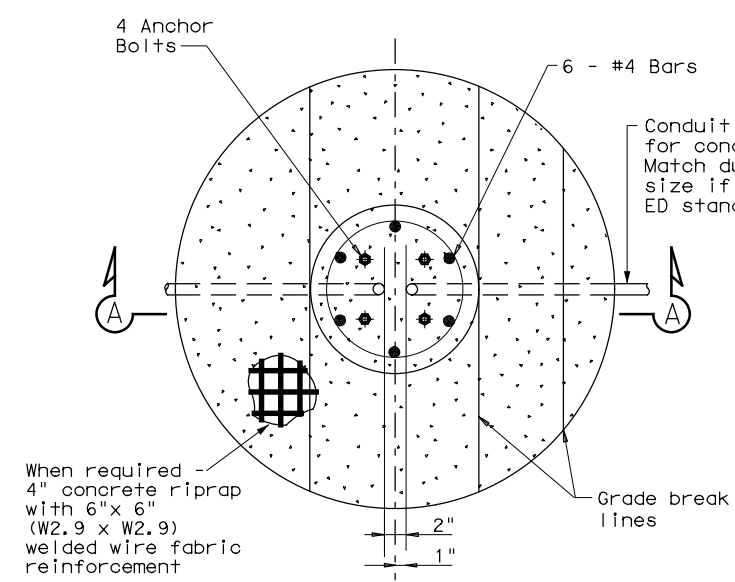

FOUNDATION DETAIL

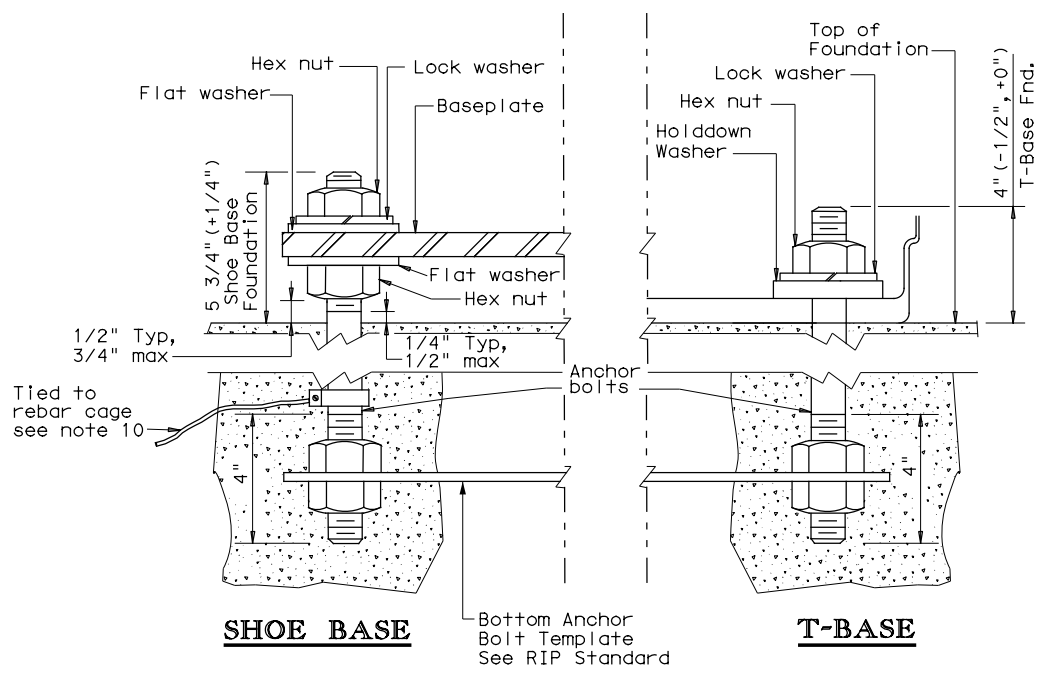

ANCHOR BOLT DETAIL

TABLE 4

BREAKAWAY POLE PLACEMENT (See note 6)

ROADWAY FUNCTIONAL CLASSIFICATION	** POLE OFFSET (DISTANCE TO FACE OF TRANSFORMER BASE)
Freeway Mainlanes (roadway with full control of access)	15 ft. (minimum and typical) from lane edge
All curbed, 45 mph or less design speed	2.5 ft. minimum (15 ft. desirable) from curb face
All others	10 ft. minimum*(15 ft. desirable) from lane edge

* or as close to ROW line as is practical

** provide 2/5 of the luminaire mounting height behind the pole for "falling area" to prevent encroachment on the other travel lanes. See design guidelines.

Texas Department of Transportation
 Traffic Safety Division Standard

ROADWAY ILLUMINATION DETAILS (RDWY ILLUM FOUNDATIONS)

RID (2) -20

FILE: rid2-20.dgn	DN:	CK:	DW:	CK:
© TxDOT January 2007	CON:	SECT:	JOB:	HIGHWAY:
REVISIONS	0910	16	180	SH 64, Etc.
1-11	DIST:	COUNTY:	SHEET NO.	
7-17	TYL	SMITH, Etc.	31	
12-20				

72B

SHIPPING PARTS LIST - POLES AND LUMINAIRE ARMS

Nominal Mounting Ht. (ft)	Shoe Base				T-Base				CSB/SSCB Mounted						
	Designation				Quantity	Designation				Quantity	Designation				Quantity
	Pole	A1	A2	Luminaire		Pole	A1	A2	Luminaire		Pole	A1	A2	Luminaire	
20	(Type SA 20 S - 4)			(150W EQ) LED		(Type SA 20 T - 4)			(150W EQ) LED						
	(Type SA 20 S - 4 - 4)			(150W EQ) LED		(Type SA 20 T - 4 - 4)			(150W EQ) LED						
30	(Type SA 30 S - 4)			(250W EQ) LED		(Type SA 30 T - 4)			(250W EQ) LED		(Type SP 28 S - 4)		(250W EQ) LED		
	(Type SA 30 S - 4 - 4)			(250W EQ) LED		(Type SA 30 T - 4 - 4)			(250W EQ) LED		(Type SP 28 S - 4 - 4)		(250W EQ) LED		
	(Type SA 30 S - 8)			(250W EQ) LED		(Type SA 30 T - 8)			(250W EQ) LED		(Type SP 28 S - 8)		(250W EQ) LED		
40	(Type SA 30 S - 8 - 8)			(250W EQ) LED		(Type SA 30 T - 8 - 8)			(250W EQ) LED		(Type SP 28 S - 8 - 8)		(250W EQ) LED		
	(Type SA 40 S - 4)			(250W EQ) LED		(Type SA 40 T - 4)			(250W EQ) LED		(Type SP 38 S - 4)		(250W EQ) LED		
	(Type SA 40 S - 4 - 4)			(250W EQ) LED		(Type SA 40 T - 4 - 4)			(250W EQ) LED		(Type SP 38 S - 4 - 4)		(250W EQ) LED		
	(Type SA 40 S - 8)			(250W EQ) LED		(Type SA 40 T - 8)			(250W EQ) LED		(Type SP 38 S - 8)		(250W EQ) LED		
	(Type SA 40 S - 8 - 8)			(250W EQ) LED		(Type SA 40 T - 8 - 8)			(250W EQ) LED		(Type SP 38 S - 8 - 8)		(250W EQ) LED		
	(Type SA 40 S - 10)			(250W EQ) LED		(Type SA 40 T - 10)			(250W EQ) LED		(Type SP 38 S - 10)		(250W EQ) LED		
	(Type SA 40 S - 10 - 10)			(250W EQ) LED		(Type SA 40 T - 10 - 10)			(250W EQ) LED		(Type SP 38 S - 10 - 10)		(250W EQ) LED		
	(Type SA 40 S - 12)			(250W EQ) LED		(Type SA 40 T - 12)			(250W EQ) LED		(Type SP 38 S - 12)		(250W EQ) LED		
50	(Type SA 40 S - 12 - 12)			(250W EQ) LED		(Type SA 40 T - 12 - 12)			(250W EQ) LED		(Type SP 38 S - 12 - 12)		(250W EQ) LED		
	(Type SA 50 S - 4)			(400W EQ) LED		(Type SA 50 T - 4)			(400W EQ) LED		(Type SP 48 S - 4)		(400W EQ) LED		
	(Type SA 50 S - 4 - 4)			(400W EQ) LED		(Type SA 50 T - 4 - 4)			(400W EQ) LED		(Type SP 48 S - 4 - 4)		(400W EQ) LED		
	(Type SA 50 S - 8)			(400W EQ) LED		(Type SA 50 T - 8)			(400W EQ) LED	12	(Type SP 48 S - 8)		(400W EQ) LED		
	(Type SA 50 S - 8 - 8)			(400W EQ) LED		(Type SA 50 T - 8 - 8)			(400W EQ) LED		(Type SP 48 S - 8 - 8)		(400W EQ) LED		
	(Type SA 50 S - 10)			(400W EQ) LED		(Type SA 50 T - 10)			(400W EQ) LED		(Type SP 48 S - 10)		(400W EQ) LED		
	(Type SA 50 S - 10 - 10)			(400W EQ) LED		(Type SA 50 T - 10 - 10)			(400W EQ) LED		(Type SP 48 S - 10 - 10)		(400W EQ) LED		
	(Type SA 50 S - 12)			(400W EQ) LED		(Type SA 50 T - 12)			(400W EQ) LED	2	(Type SP 48 S - 12)		(400W EQ) LED		
	(Type SA 50 S - 12 - 12)			(400W EQ) LED		(Type SA 50 T - 12 - 12)			(400W EQ) LED		(Type SP 48 S - 12 - 12)		(400W EQ) LED		

OTHER				
Designation				Quantity
Pole	A1	A2	Luminaire	

DISCLAIMER: The use of this standard is governed by the "Texas Engineering Practice Act". No warranty of any kind is made by TxDOT for any purpose whatsoever. TxDOT assumes no responsibility for the conversion of this standard to other formats or for incorrect results or damages resulting from its use.

DATE: 5/16/2024 9:33:03 AM
 FILE: c:\pwworking\infRatech\In.Zhang\dms47076\rip(1-4)-19 (3).dgn

GENERAL NOTES:

- All work, materials and services not shown on the plans which may be necessary for complete and proper construction shall be performed, furnished and installed by the Contractor. Faulty fabrication or poor workmanship in any material, equipment or installation will be considered justification for rejection. Where manufacturers provide warranties or guarantees as a customary trade practice, furnish to the Department such warranties or guarantees.
- The location of poles and fixtures are diagrammatic only and may be shifted by the Engineer to accommodate local conditions. Install or remove poles and luminaires located near overhead electrical lines using established industry and utility safety practices and in accordance with laws governing such work. Consult with the appropriate utility company prior to beginning such work.
- Standard Steel Pole Designs. Steel poles fabricated in accordance with the details and dimensions shown herein, shall be considered standard designs. Submission of shop drawings and design calculations for standard designs is not required.
- Optional Steel Pole Designs. Multi-sided steel poles may be allowed as optional designs, if steel poles are permitted or required, pending approval by the Department as outlined below.
 - Shop Drawings. Optional designs require submission of shop drawings and design calculations bearing the seal of an engineer licensed in the State of Texas, in accordance with Item 441, "Steel Structures." The Department may elect to pre-approve some shop drawings for optionally designed poles. Submission of shop drawings and design calculations is not required for structures fabricated in accordance with the details of shop drawings on the pre-approved list maintained by the TxDOT Traffic Operations Division. Any deviation from the pre-approved shop drawings will require submission of shop drawings of the complete assembly and design calculations as described above.
 - Structural Support Design for Luminaires. Lighting support structures shall be designed for a 25 year design life in accordance with the AASHTO Standard Specifications for Structural Supports for Highway Signs, Luminaires and Traffic Signals, 6th Edition (2013) and Interim Revisions thereto. All poles shall be designed for 110 mph 3-second gust wind speeds. The Gust Factor, G, and Wind Importance Factor, Ir, shall be applied as per the AASHTO Specifications assuming a 25-year design life. The design wind pressure for hurricane wind velocities greater than 100 mph shall not be less than the design wind pressure using 100 mph with the non-hurricane Wind Importance Factor, Ir, value. For transformer base poles, fabricator shall include transformer base and connecting hardware in design calculations and shop drawing submittals. All transformer bases shall have been structurally tested to resist the theoretical plastic moment capacity of the pole. Certification of the plastic moment load test and FHWA breakaway requirement test of the model of base being furnished shall be submitted with the shop drawings. Shop drawings shall show breakaway base model number, and manufacturer's name and logo. Manufacturer's shop drawings shall include the ASTM designations for all materials to be used.
 - Mast Arm Attachments. All poles and attachments shall be structurally designed to support two 12-foot mast arms and luminaires. Poles shall be supplied with mast arm combinations as shown in the plans. All mast arms shall be designed for a 60-pound luminaire having an effective projected area of 1.6 square feet.
 - Anchor Bolt Assembly. Anchor bolt assemblies for optionally designed poles shall be the same as those shown herein.
- Aluminum Pole Designs. Aluminum pole designs may be allowed, if aluminum poles are permitted or required, pending approval by the Department as outlined below.
 - Meet all of the requirements stated above for optional steel pole designs and the following:
 - Aluminum poles shall be fabricated in accordance with "Structural Welding Code-Aluminum" AWS D1.2.
 - Aluminum pole designs shall use the same anchor bolt assembly and be subject to the same geometric restraints and other requirements for steel poles specified herein.
 - Aluminum poles shall be equipped with vibration mitigation devices, as approved by the engineer.
 - Pole components shall be constructed using the following material:
 - Shaft: ASTM B221 or B241 Alloy 6063-T6, ASTM B209 Alloy 5086-H34, ASTM B221 Alloy 6005-T5.
 - Base Flange: ASTM B26 Alloy 356.0-T6 or ASTM B108 Alloy 356.0-T6 (Yield strength test required).
 - Mast Arm Fitting: ASTM B209 Alloy 6061-T6 or ASTM B221 Alloy 6005-T5.
 - Mast Arms: ASTM B241 Alloy 6061-T6 or Alloy 6063-T6.
 - Pole Cap: ASTM B209 Alloy 5086-H32 or ASTM B108 or B26 Alloy 356.0-T6.
 - Bolts: Stainless Steel AISI 300 series. Bolts threading into aluminum threads shall be treated with anti-seize compound, Never-Seez Compound, Permatex 133K or equal.
- Special Designs. Poles with architectural treatments shall meet the requirements shown elsewhere in the plans.
- Luminaire Mounting Height. Actual luminaire mounting height shall be the nominal mounting height given on RIP(2) for all pole-arm combinations except for poles with 4 ft. luminaire arms, which shall be 3'-0" lower than the nominal height, unless otherwise shown or directed.

EXPLANATION OF ROADWAY ILLUMINATION ASSEMBLY DESIGNATIONS

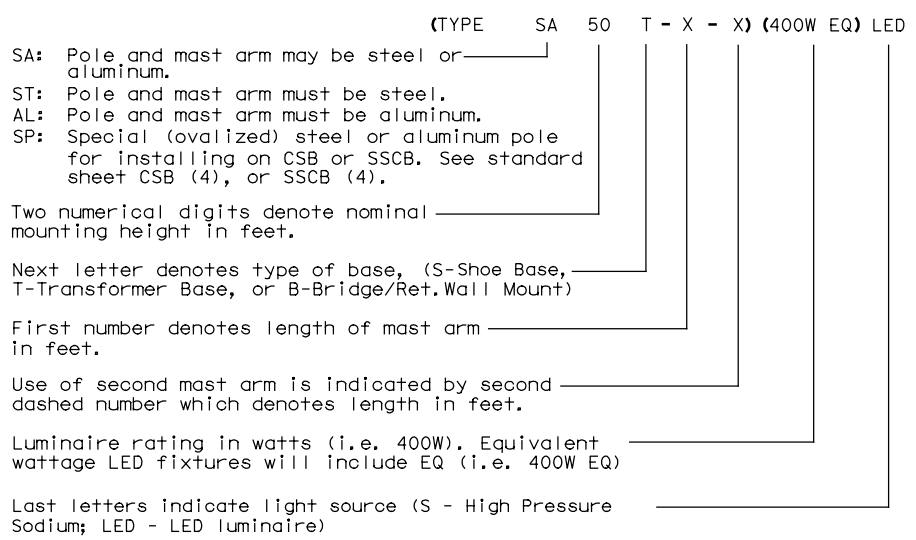

Texas Department of Transportation

Traffic Safety Division Standard

ROADWAY ILLUMINATION POLES

RIP(1)-19

FILE: rip-19.dgn	DN:	CK:	DW:	CK:
© TxDOT January 2007	CONT	SECT	JOB	HIGHWAY
REVISIONS		091016	180	SH 64, Etc.
7-17	DIST	COUNTY	SHEET NO.	
12-19	TYL	SMITH, Etc.	32	

73A

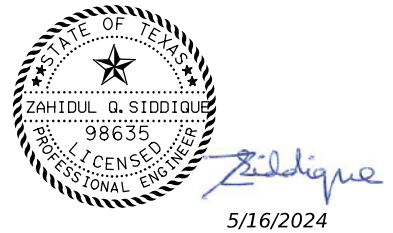

DISCLAIMER: The use of this standard is governed by the "Texas Engineering Practice Act". No warranty of any kind is made by TxDOT for any purpose whatsoever. TxDOT assumes no responsibility for the conversion of this standard to other formats or for incorrect results or damages resulting from its use.

DATE: 5/16/2024 9:33:04 AM
 FILE: c:\pww-int\FracTech\Lin.Zhang\dms47076\rip(1-4)-19 (3).dgn

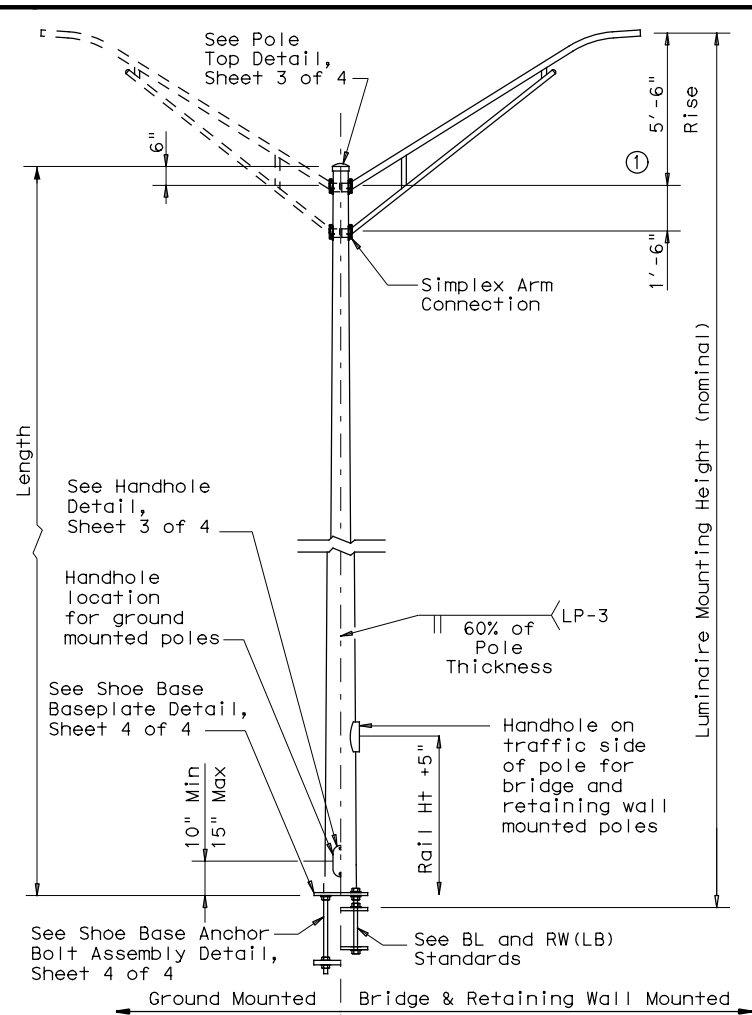

SHOE BASE POLE

SHOE BASE POLE					
Luminaire Mounting Height (Nominal) (ft)	Base Diameter (in)	Top Diameter (in)	Length (ft)	Pole Thickness (in)	Design Moment (K-ft)
20.00	7.00	4.90	15.00	0.1196	7.1
30.00	7.50	4.00	25.00	0.1196	13.2
31.00-39.00	8.00	4.36-3.24	26.00-34.00	0.1196	20.7
40.00	8.50	3.60	35.00	0.1196	20.7
50.00	10.50	4.20	45.00	0.1196	30.3

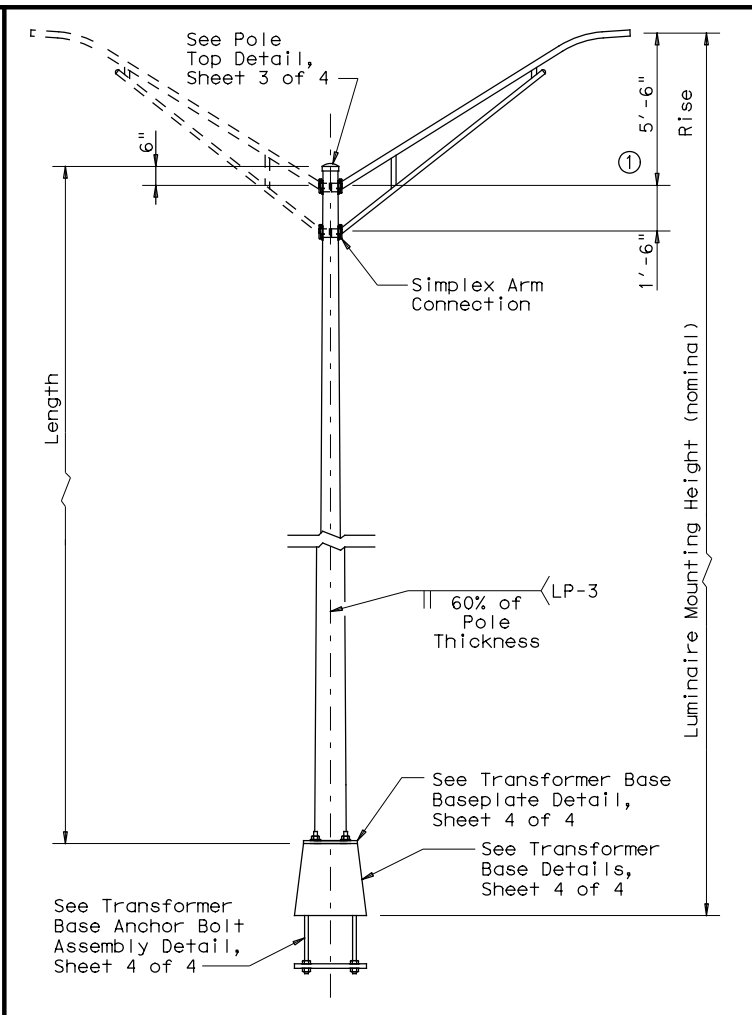

TRANSFORMER BASE POLE

TRANSFORMER BASE POLE					
Luminaire Mounting Height (Nominal) (ft)	Base Diameter (in)	Top Diameter (in)	Length (ft)	Pole Thickness (in)	Design Moment (K-ft)
20.00	7.00	5.11	13.50	0.1196	7.1
30.00	7.50	4.21	23.50	0.1196	13.2
31.00-39.00	8.00	4.57-3.45	24.50-32.50	0.1196	20.7
40.00	8.50	3.81	33.50	0.1196	20.7
50.00	10.00	3.91	43.50	0.1196	30.3

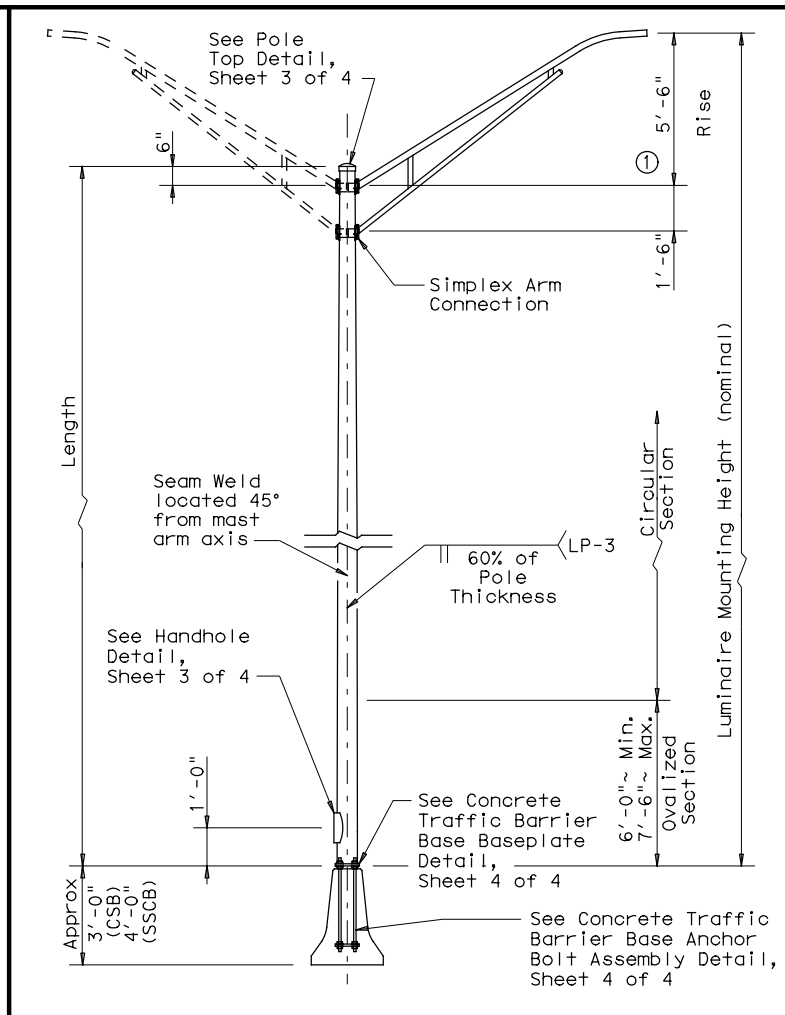

CONCRETE TRAFFIC BARRIER BASE POLE

CONCRETE TRAFFIC BARRIER BASE POLE (CSB/SSCB)						
Luminaire Mounting Height (Nominal) (ft)	Base Diameter (in)	Top Diameter (in)	Length (ft)	Pole Thickness (in)	Design Moment (K-ft)	
					About C of Rail	Perp. to Rail
28.00	9.00	5.78	23.00	0.1196	10.3	13.2
38.00	9.00	4.38	33.00	0.1196	16.6	20.8
48.00	10.50	4.48	43.00	0.1345	25.1	30.5

GENERAL NOTES:

- Designs conform to AASHTO Standard Specifications for Structural Supports for Highway Signs, Luminaires, and Traffic Signals, 6th Edition (2013) and Interim Revisions thereto. Design 3-Second Gust Wind Speed equals 110 mph with a 1.14 gust factor. A wind importance factor of 0.80 is applied to adjust the wind speed to a 25 year recurrence interval. Design moments listed in tables assume base of pole is 25' above natural ground level.
- Structures are designed to support two 12' luminaire mast arms and luminaires. Mast arms are designed to support a 60-pound luminaire having an effective projected area of 1.6 square feet.
- Fabrication shall be in accordance with the Specifications and with the details, dimensions, and weld procedures shown herein. Do not submit shop drawings for roadway illumination pole assemblies fabricated in accordance with the details, dimensions, and weld procedures shown herein. Weld references call for preapproved weld procedures which the Fabricator must obtain prior to fabrication. Materials, fabrication tolerances, and shipping practices shall meet the requirements of these sheets and the Specifications. In the absence of specified fabrication tolerances, dimensions shall be within the tolerances generally obtainable in normal fabrication practice.
- For mounting heights between values shown in the tables, use base diameter and thickness values for the larger height.
- Unless otherwise noted, all steel parts shall be galvanized in accordance with Item 445, "Galvanizing."
- Steel poles shall be fabricated in accordance with Item 441, "Steel Structures." Longitudinal seam welds for pole sections shall have 60% minimum penetration. All welding shall be in accordance with AWS D1.1, Structural Welding Code-Steel.
- Two-section poles joined by circumferential welds will not be permitted, unless otherwise shown on the plans. Poles may be fabricated in two sections and field-assembled by the lap-joint method. The two sections shall telescope together with a lap length of not less than 1-1/2 times the shaft diameter at the lap joint.
- Alternate material equal to or better than material specified may be substituted with the approval of the Engineer.
- Lubricate and tighten anchor bolts, when erecting shoe base poles and concrete traffic barrier base poles, in accordance with Item 449, "Anchor Bolts."
- All poles, except Transformer Base Poles, shall have hand holes with reinforcing frames and covers. For ground mounted shoe base poles, hand holes shall be placed 90 degrees to mast arm unless otherwise noted on the plans. For poles mounted on a concrete traffic barrier with one luminaire arm, hand holes shall be located 180 degrees from luminaire arm. For poles mounted on a concrete traffic barrier with two luminaire arms, all hand holes shall be on the same side of the barrier. For poles mounted on a bridge lighting bracket or a retaining wall lighting bracket, hand hole shall be on traffic side of the pole, at a height that will clear the barrier.
- The finished pole shall have a smooth, uniform finish free of pits, blisters, or other defects. Scratched, chipped, and other damaged galvanized areas on poles and mast arms shall be repaired in accordance with Item 445, "Galvanizing."
- Pole length is based on a 5'-6" luminaire arm rise. 4 ft. luminaire arms have a 2'-6" rise. A pole with 4 ft. luminaire arms will have an actual mounting height 3'-0" less than the nominal mounting height. Increasing the pole length to meet the nominal mounting height is allowed, but unnecessary unless otherwise directed by the engineer.
- Erect transformer base poles in accordance with sheet RID(1).

MATERIAL DATA

COMPONENT	ASTM DESIGNATION	MIN. YIELD (ksi)
Pole Shaft (0.14"/ft. Taper)	A572 Gr 50, A595 Gr A, A1011 HSLAS Gr 50 Cl 2 ③, or A1008 HSLAS Gr 50 Cl 2	50
Base Plate and Handhole Frame	A572 Gr.50, or A36	36
T-Base Connecting Bolts	F3125 Gr A325	92
Anchor Bolts	F1554 Gr 55, A193-B7 or A321	55 105
Anchor Bolt Templates	A36	36
Heavy Hex (H.H.) Nuts	A194 Gr 2H, or A563 Gr DH	
Flat Washers	F436	

NOTES:

- 2'-6" rise for 4 ft. luminaire arms.
- Before ovalized as shown on Concrete Traffic Barrier Base Baseplate details, Sheet 4 of 4.
- A1011 SS Gr 50 may be used instead of HSLAS, provided the material meets the elongation requirements for HSLAS.

POLE ASSEMBLY FABRICATION TOLERANCES TABLE

DIMENSION	TOLERANCE
Shaft length	+1"
I.D. of outside piece of slip fitting pieces	+1/8", -1/16"
O.D. of inside piece of slip fitting pieces	+1/32", -1/8"
Shaft diameter: other	+3/16"
Out of "round"	1/4"
Straightness of shaft	±1/4" in 10 ft
Twist in multi-sided shaft	4° in 50 ft
Perpendicular to baseplate	1/8" in 24"
Pole centered on baseplate	±1/4"
Location of Attachments	±1/4"
Bolt hole spacing	±1/16"

SHEET 2 OF 4



ROADWAY ILLUMINATION POLES

RIP (2) - 19

FILE: rip-19.dgn	DN:	CK:	DW:	CK:
© TxDOT January 2007	CON:	SECT:	JOB:	HIGHWAY:
REVISIONS	091016	180	SH 64, Etc.	
7-17	DIST:	COUNTY:	SHEET NO.	
12-19	TYL	SMITH, Etc.	33	

DISCLAIMER: The use of this standard is governed by the "Texas Engineering Practice Act". No warranty of any kind is made by TxDOT for any purpose whatsoever. TxDOT assumes no responsibility for the conversion of this standard to other formats or for incorrect results or damages resulting from its use.

DATE: 5/16/2024 9:33:04 AM
 FILE: c:\pw-infrastructure\in.zhang\dms47076\rip(1-4)-19 (3).dgn

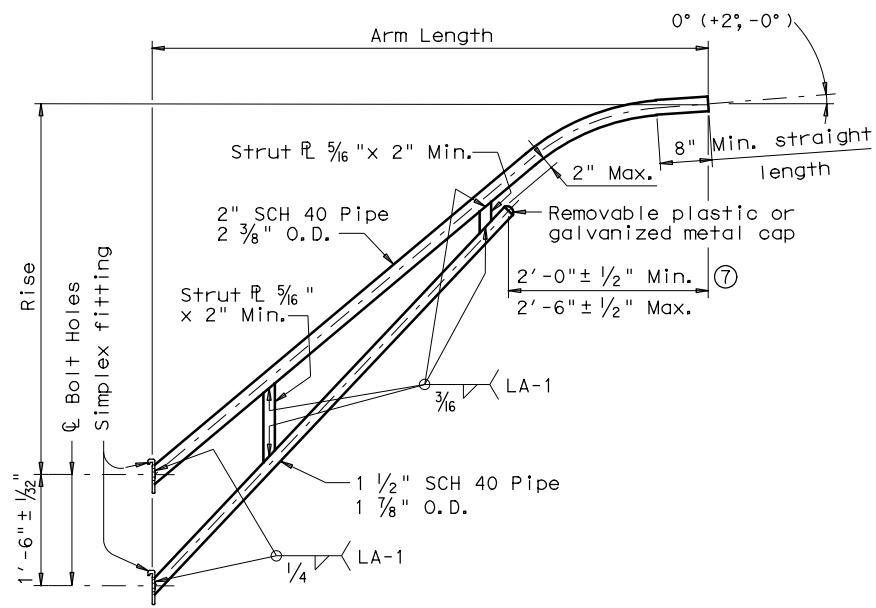

LUMINAIRE ARM

LUMINAIRE ARM DIMENSIONS		
Nominal Arm Length	Arm Length	Rise
4'-0"	3'-6"	2'-6"
6'-0"	5'-6"	5'-6"
8'-0"	7'-6"	5'-6"
10'-0"	9'-6"	5'-6"
12'-0"	11'-6"	5'-6"

ARM ASSEMBLY FABRICATION TOLERANCES TABLE	
DIMENSION	TOLERANCE
Arm Length	±1"
Arm Rise	±1"
Deviation from flat	1/8" in 12"
Spacing between holes	±1/32"

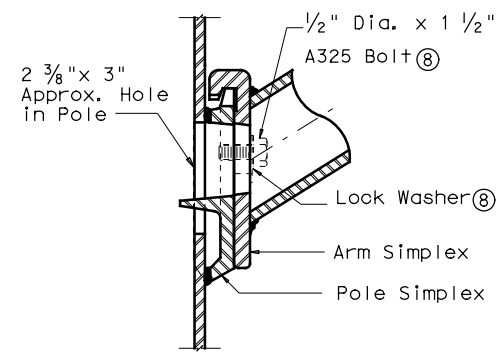

UPPER SIMPLEX FITTING
 (Gusset not shown for clarity)

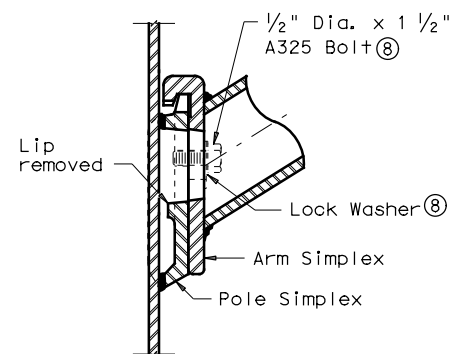

LOWER SIMPLEX FITTING
 (Gusset not shown for clarity)

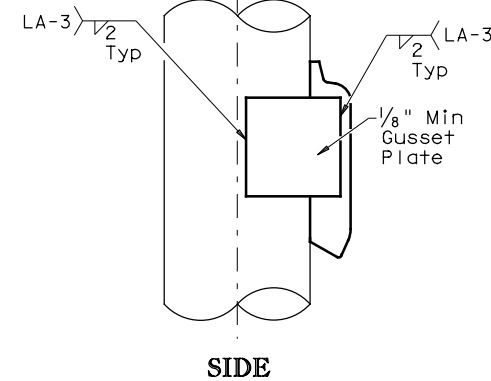

SIDE

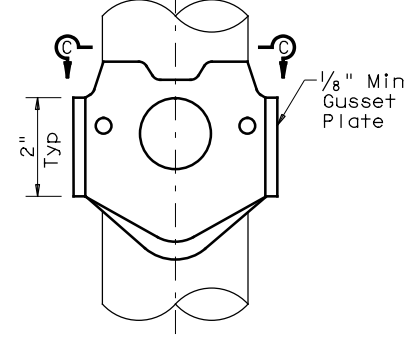

ELEVATION

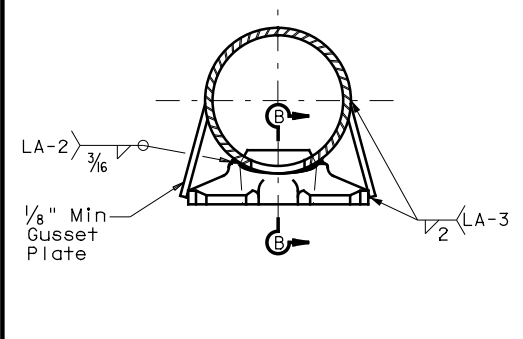

SECTION C-C

SIMPLEX ATTACHMENT DETAIL

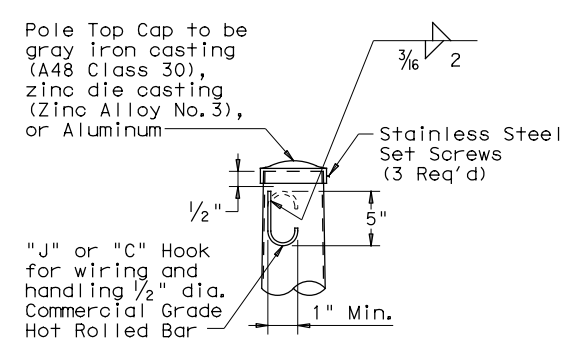

POLE TOP

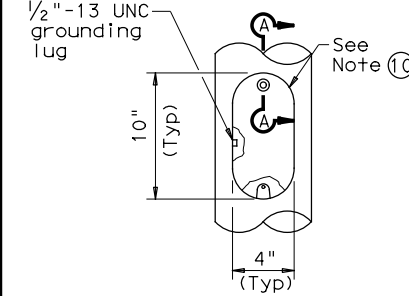

ELEVATION

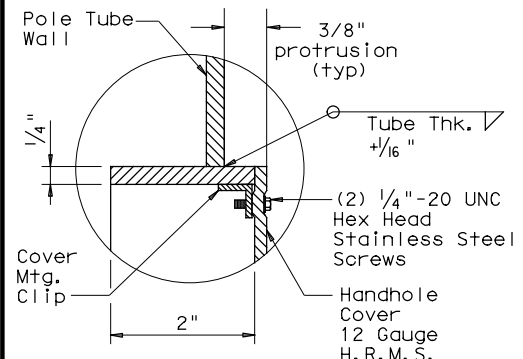

SECTION A-A

HANDHOLE

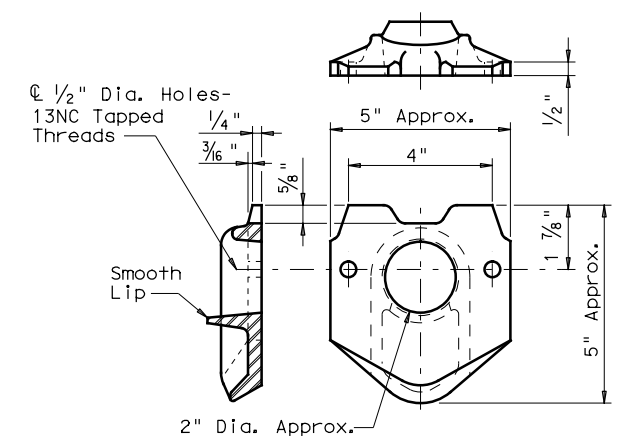

POLE SIMPLEX DETAIL ③

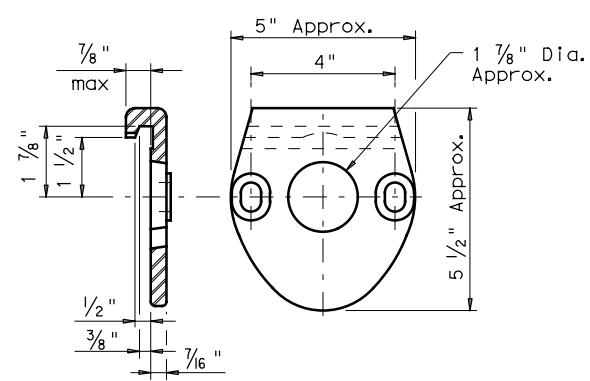

ARM SIMPLEX DETAIL ③

NOTES:

- ④ Any of the materials listed for plates may be used where the drawings do not specify a particular ASTM designation.
- ⑤ A576 must be suitable for forging and also meet minimum tensile strength of 65 ksi, minimum yield of 35 ksi, and elongation in 2 inches of 22 percent.
- ⑥ A572, A1008 HSLAS-F, and A1011 HSLAS-F materials may have higher yield strengths but shall not have less elongation than the grade indicated.
- ⑦ Dimensional limits are given to show acceptable variation in design. All of a Fabricator's production of a particular arm length shall have the same dimensions within specified tolerances.
- ⑧ Each pole simplex fitting shall be supplied with 2 bolts and 2 lock washers of the size specified. The bolts and lock washers shall be secured to the pole with the other hardware items called for in the plans.
- ⑨ Proposed deviations in arm simplex dimensions or materials must be submitted to the Department for approval.
- ⑩ A welded handhole frame is permissible. Maximum of two (2) CJP weld splices is allowed.

MATERIALS

Pole or Arm Simplex	ASTM A27 Gr 65-35 or Gr 70-36, A148 Gr 80-50, A576 Gr 1021 ⑤, or A36 (Arm only)
Arm Pipes	ASTM A53 Gr A or B, A500 Gr B, A501, A 1008 HSLAS-F Gr 50 ⑥, or A1011 HSLAS-F Gr 50 ⑥
Arm Struts and Gusset Plates ④	ASTM A36, A572 Gr 50 ⑥, or A588
Misc.	ASTM designations as noted

SHEET 3 OF 4



ROADWAY ILLUMINATION POLES
RIP (3) - 19

FILE: rip-19.dgn	DN:	CK:	DW:	CK:
© TxDOT January 2007	CONT	SECT	JOB	HIGHWAY
REVISIONS	0910	16	180	SH 64, Etc.
7-17	DIST	COUNTY	SHEET NO.	
12-19	TYL	SMITH, Etc.	34	

73C

DISCLAIMER: The use of this standard is governed by the "Texas Engineering Practice Act". No warranty of any kind is made by TxDOT for any purpose whatsoever. TxDOT assumes no responsibility for the conversion of this standard to other formats or for incorrect results or damages resulting from its use.

DATE: 5/16/2024 9:33:04 AM
 FILE: c:\pw-InfraTech\in.Zhang\dms47076\rip(1-4)-19 (3).dgn

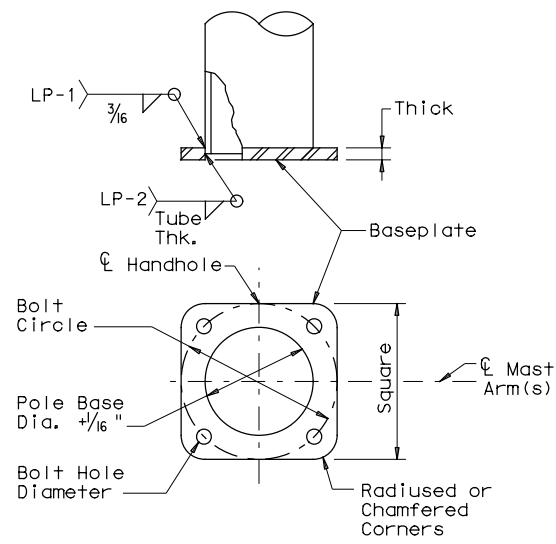

SHOE BASE BASEPLATE

SHOE BASE BASEPLATE TABLE				
MOUNTING HEIGHTS (nominal)	BOLT CIRCLE	SQUARE	THICK	BOLT HOLE DIAMETER
20' - 39'	13"	13"	1 1/4"	1 1/4"
40'	15"	15"	1 1/4"	1 1/2"
50'	15"	15"	1 1/2"	1 1/2"

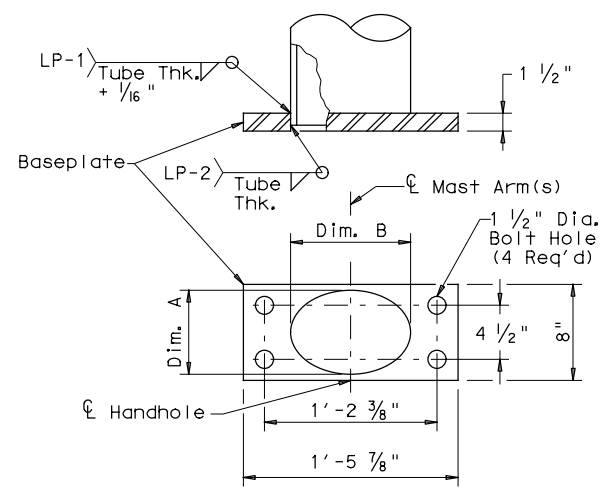

CONCRETE TRAFFIC BARRIER BASE BASEPLATE

CONCRETE TRAFFIC BARRIER BASE BASEPLATE TABLE			
MOUNTING HEIGHTS (nominal)	POLE DIA. (12)	DIM. A	DIM. B
28' - 38'	9"	7" ± 1/4"	10" ± 1/4"
48'	10 1/2"	7" ± 1/4"	13" ± 1/4"

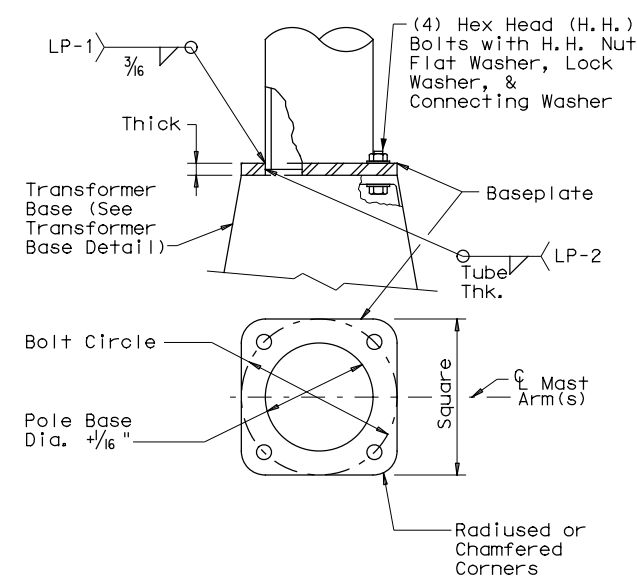

TRANSFORMER BASE BASEPLATE

TRANSFORMER BASE BASEPLATE TABLE						
MOUNTING HEIGHTS (nominal)	BOLT CIRCLE	SQUARE	THICK	CONNECTING BOLT DIA.	BOLT HOLE DIAMETER	TRANSFORMER BASE TYPE
20' - 39'	13"	13"	1 1/4"	1"	1 1/4"	A
40'	15"	15"	1 1/4"	1 1/4"	1 1/2"	B
50'	15"	15"	1 1/2"	1 1/4"	1 1/2"	B

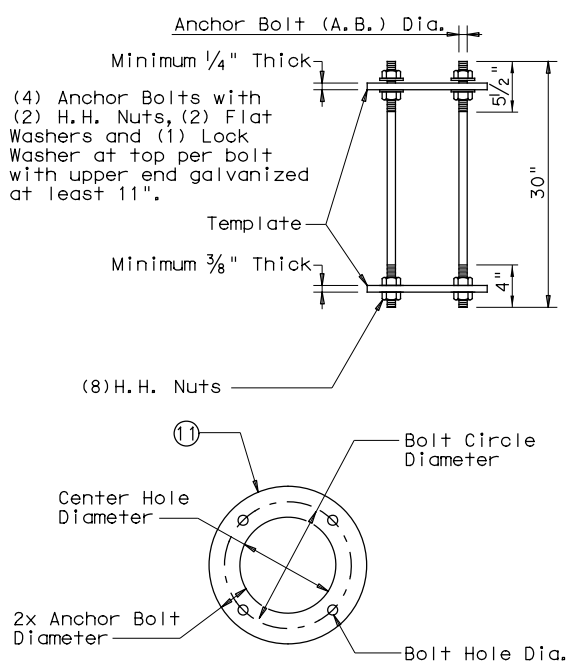

SHOE BASE ANCHOR BOLT ASSEMBLY

SHOE BASE ANCHOR BOLT ASSEMBLY TABLE				
MOUNTING HEIGHTS (nominal)	A.B. Dia.	BOLT CIRCLE DIAMETER	CTR. HOLE DIAMETER	BOLT HOLE DIAMETER
20' - 39'	1"	13"	11"	1 1/16"
40' - 50'	1 1/4"	15"	12 1/2"	1 5/16"

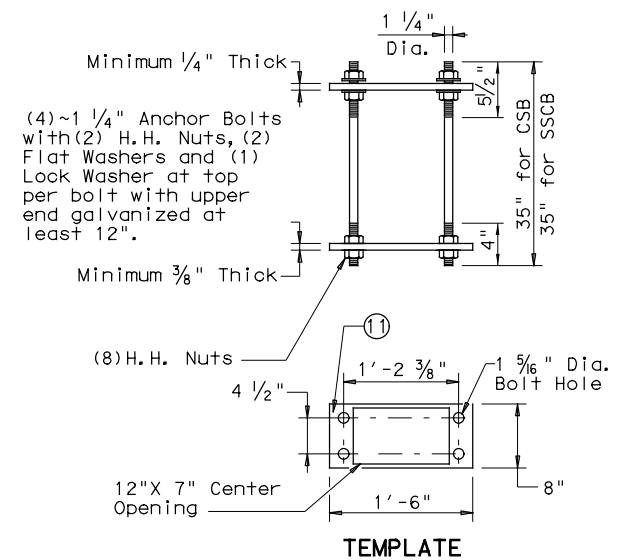

CONCRETE TRAFFIC BARRIER BASE ANCHOR BOLT ASSEMBLY

TRANSFORMER BASE ANCHOR BOLT ASSEMBLY TABLE				
MOUNTING HEIGHTS (nominal)	A.B. Dia.	BOLT CIRCLE DIAMETER	CTR. HOLE DIAMETER	BOLT HOLE DIAMETER
20' - 39'	1"	14"	12"	1 1/16"
40' - 50'	1 1/4"	17 1/4"	14 3/4"	1 5/16"

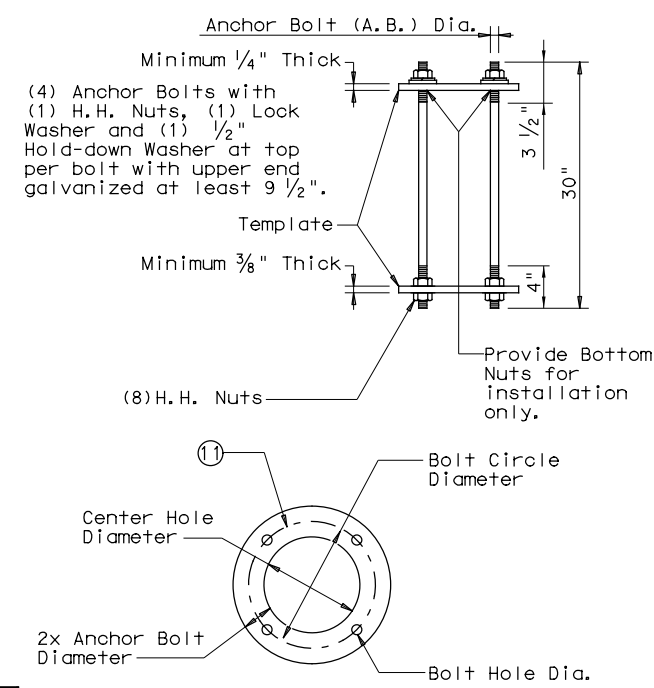

TRANSFORMER BASE ANCHOR BOLT ASSEMBLY

TRANSFORMER BASE TABLE		
TYPE	TOP B.C.	BTM. B.C.
A	13"	14"
B	15"	17 1/4"

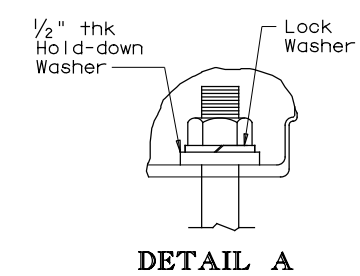

DETAIL A

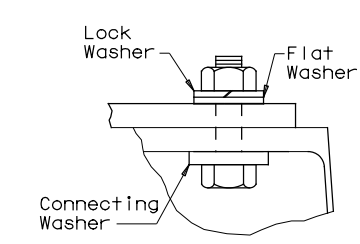

DETAIL B

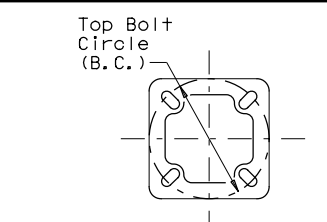

TOP PLAN

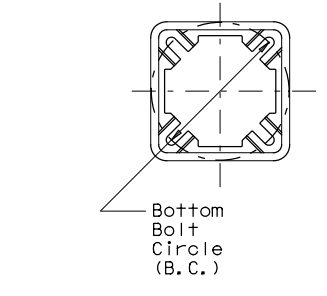

BOTTOM PLAN

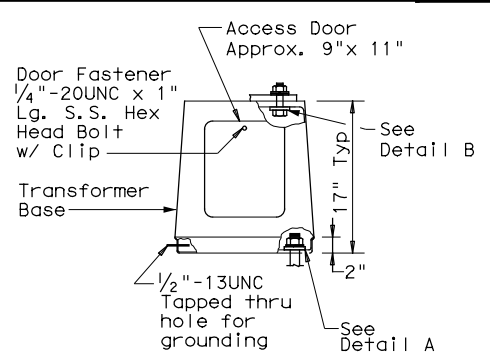

ELEVATION

TRANSFORMER BASE DETAILS

GENERAL NOTES:

- For mounting heights between those shown in the table, use the values in the table for the larger mounting height.
- All breakaway bases shall meet the breakaway requirements of the AASHTO Standard Specifications for Structural Supports for Highway Signs, Luminaires and Traffic Signals, 6th Edition (2013) and Interim Revisions thereto, and shall have been tested by FHWA-approved methods. All bases shall have been structurally tested to resist 150% of the design moment.
- Transformer bases shall be cast from aluminum, ASTM B108 or B26 Alloy 356.0-T6, or other material approved by the Engineer. Four Hex Head (H.H.) bolts with four H.H. nuts, four lock washers, four flat washers, and connecting and hold-down washers as recommended by the manufacturer, galvanized to ASTM A153 Class C or D, or B695 Class 50, shall be provided with each transformer base for connecting the pole. Bolts shall be ASTM A325 or approved equal. Nuts shall be ASTM A563 grade DH galvanized.
- Bases shall be stamped, incised or by other approved permanent means, marked to show fabricator's name or logo, and model number. Such information shall be placed in a readily seen location, inside or outside the base, but shall not be placed on the door.
- Doors for transformer bases shall be made of plastic, fiberglass or other non-metallic material approved by the Engineer and shall be attached with stainless steel screws or bolts. Transformer bases shall be cleaned by grit blast cleaning after heat treatment. Certification by the manufacturer of heat treatment shall be furnished with transformer bases. The certification shall show the metal alloy and temper and that the base meets those requirements, chemical and physical. The certification shall also show the material ASTM specification. Transformer bases shall be cast with a removable tab bar for material testing. Some bars may have been removed by the manufacturer for testing.

NOTES:

- Anchor Bolt Templates do not need to be galvanized.
- Pole diameter before ovalized.

ANCHOR BOLT FABRICATION TOLERANCES TABLE	
DIMENSION	TOLERANCE
Length	± 1/2"
Threaded length	± 1/2"
Galvanized length (if required)	- 1/4"

SHEET 4 OF 4



**ROADWAY ILLUMINATION POLES
 RIP (4) - 19**

FILE: rip-19.dgn	DN:	CK:	DW:	CK:
© TxDOT January 2007	CON:	SECT:	JOB:	HIGHWAY:
REVISIONS	0910	16	180	SH 64, Etc.
7-17	DIST:	COUNTY:	SHEET NO.:	
12-19	TYL	SMITH, Etc.		35

730

STORMWATER POLLUTION PREVENTION PLAN (SWP3):

2.0 BEST MANAGEMENT PRACTICES (BMPs) AND CONTROLS, INSPECTION, AND MAINTENANCE

The Contractor shall be the responsible party for implementing the BMPs described herein and for complying with the SWP3 for control of erosion and sedimentation during day-to-day operations. The Contractor shall implement changes to this SWP3 approved by TxDOT within the times specified in this SWP3 or the CGP.

2.1 EROSION CONTROL AND SOIL STABILIZATION BMPs:

T / P

- Protection of Existing Vegetation
- Vegetated Buffer Zones
- Soil Retention Blankets
- Geotextiles
- Mulching/ Hydromulching
- Soil Surface Treatments
- Temporary Seeding
- Permanent Planting, Sodding or Seeding
- Biodegradable Erosion Control Logs
- Rock Filter Dams/ Rock Check Dams
- Vertical Tracking
- Interceptor Swale
- Riprap
- Diversion Dike
- Temporary Pipe Slope Drain
- Embankment for Erosion Control
- Paved Flumes
- Other: Update if project scope changes
- Other: _____
- Other: _____
- Other: _____

2.2 SEDIMENT CONTROL BMPs:

T / P

- Biodegradable Erosion Control Logs
- Dewatering Controls
- Inlet Protection
- Rock Filter Dams/ Rock Check Dams
- Sandbag Berms
- Sediment Control Fence
- Stabilized Construction Exit
- Floating Turbidity Barrier
- Vegetated Buffer Zones
- Vegetated Filter Strips
- Other: Update if project scope changes
- Other: _____
- Other: _____
- Other: _____

Refer to the Environmental Layout Sheets/ SWP3 Layout Sheets located in Attachment 1.2 of this SWP3

2.3 PERMANENT CONTROLS:

(Coordinate post-construction BMPs with appropriate TxDOT maintenance sections.)

BMPs To Be Left In Place Post Construction:

Type	Stationing	
	From	To
N/A		

Refer to the Environmental Layout Sheets/ SWP3 Layout Sheets located in Attachment 1.2 of this SWP3

2.4 OFFSITE VEHICLE TRACKING CONTROLS:

- Excess dirt/mud on road removed daily
- Haul roads dampened for dust control
- Loaded haul trucks to be covered with tarpaulin
- Stabilized construction exit
- Daily street sweeping
- Other: N/A

Other: _____

Other: _____

Other: _____

2.5 POLLUTION PREVENTION MEASURES:

- Chemical Management
- Concrete and Materials Waste Management
- Debris and Trash Management
- Dust Control
- Sanitary Facilities
- Other: Update If project scope changes

Other: _____

Other: _____

Other: _____

2.6 VEGETATED BUFFER ZONES:

Natural vegetated buffers shall be maintained as feasible to protect adjacent surface waters. If vegetated natural buffer zones are not feasible due to site geometry, the appropriate additional sediment control measures have been incorporated into this SWP3.

Type	Stationing	
	From	To
Preserve all existing vegetation, but clearing, grubbing trees within ROW		

Refer to the Environmental Layout Sheets/ SWP3 Layout Sheets located in Attachment 1.2 of this SWP3

2.7 ALLOWABLE NON-STORMWATER DISCHARGES:

- Fire hydrant flushings
- Irrigation drainage
- Pavement washwater (where spills or leaks have not occurred, and detergents are not used)
- Potable water sources
- Springs
- Uncontaminated groundwater
- Water used to wash vehicles or control dust
- Other allowable non-stormwater discharges as allowed by TPDES GP TXR150000.

2.8 DEWATERING:

2.9 INSPECTIONS:

All disturbed areas and erosion and sediment control devices shall be inspected at least once every seven (7) days. Inspections shall be performed by TxDOT as indicated on the Field Inspection and Maintenance Report Form 2118 and retained in Attachment 2.3 of this SWP3 .

2.10 MAINTENANCE:

Control measures shall be properly installed according to specifications. If it is determined that a BMP or control measure is not operating effectively, maintenance must be accomplished as soon as possible and before the next anticipated rain event, but in no case later than 7 calendar days after being able to access the site. Maintenance shall be performed by the Contractor as indicated on the Field Inspection and Maintenance Report Form 2118 and retained in Attachment 2.3 of this SWP3.

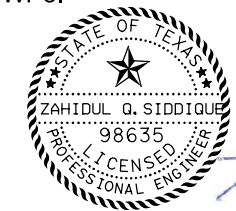

Z. Siddique
5/16/2024

STORMWATER POLLUTION PREVENTION PLAN (SWP3) (Less Than 1 Acre)

FED. RD. DIV. NO.	PROJECT NO.			SHEET NO.
				36
STATE	STATE DIST.	COUNTY		
TEXAS	TYL	SMITH, ETC		
CONT.	SECT.	JOB	HIGHWAY NO.	
0910	16	180	SH 64, ETC	

STORMWATER POLLUTION PREVENTION PLAN (SWP3):

This SWP3 has been developed in accordance with TxDOT policy for projects disturbing less than 1 acre of soil, and not part of a larger common plan of development.

This SWP3 is consistent with requirements specified in applicable stormwater plans, and the project's environmental permits, issues, and commitments (EPICs).

1.0 SITE/PROJECT DESCRIPTION

1.1 PROJECT CONTROL SECTION JOB (CSJ):

0910 - 16 - 180

1.2 PROJECT LIMITS:

Various Locations: SH 64 AT FM 15, SH 64 AT FM 848

SH 64 AT FM 2089, AND US 259 AT FM 850

1.3 PROJECT COORDINATES:

BEGIN: (Lat) _____, (Long) _____

END: (Lat) _____, (Long) _____

1.4 TOTAL PROJECT AREA (Acres): 1.0

1.5 TOTAL AREA TO BE DISTURBED (Acres): 0.0

1.6 NATURE OF CONSTRUCTION ACTIVITY:

Installing roadway illumination for intersections and turning lanes

1.7 MAJOR SOIL TYPES:

Soil Type	Description

1.8 PROJECT SPECIFIC LOCATIONS (PSLs):

PSLs must be depicted on the Environmental Layout Sheets in Attachment 1.2 of this SWP3. PSLs may be identified during preconstruction meetings or during the construction process. Please choose from the options below:

- PSLs determined during preconstruction meeting
- PSLs determined during construction
- No PSLs planned for construction

Type	Sheet #s
N/A	N/A

All off-ROW PSLs required by the Contractor are the Contractor's responsibility. The Contractor shall secure all permits required by local, state, federal laws for off-ROW PSLs. The contractor shall provide diagrams, areas of disturbance, acreage, and BMPs for all off-ROW PSLs within one mile of the project.

1.9 CONSTRUCTION ACTIVITIES:

(Use the following list as a starting point when developing the Construction Activity Schedule and Ceasing Record in Attachment 2.3.)

- Mobilization
- Install sediment and erosion controls
- Blade existing topsoil into windrows, prep ROW, clear and grub
- Remove existing pavement
- Grading operations, excavation, and embankment
- Excavate and prepare subgrade for proposed pavement widening
- Remove existing culverts, safety end treatments (SETs)
- Remove existing metal beam guard fence (MBGF), bridge rail
- Install proposed pavement per plans
- Install culverts, culvert extensions, SETs
- Install mow strip, MBGF, bridge rail
- Place flex base
- Rework slopes, grade ditches
- Blade windrowed material back across slopes
- Revegetation of unpaved areas
- Achieve site stabilization and remove sediment and erosion control measures
- Other: Update if project scope changes to require soil disturbing activities. None planned at this time.

Other: _____

Other: _____

1.10 POTENTIAL POLLUTANTS AND SOURCES:

- Sediment laden stormwater from stormwater conveyance over disturbed area
- Fuels, oils, and lubricants from construction vehicles, equipment, and storage
- Solvents, paints, adhesives, etc. from various construction activities
- Transported soils from offsite vehicle tracking
- Construction debris and waste from various construction activities
- Contaminated water from excavation or dewatering pump-out water
- Sanitary waste from onsite restroom facilities
- Trash from various construction activities/receptacles
- Long-term stockpiles of material and waste
- _____

Other: Update if project scope changes to require soil disturbing activities. None planned at this time.

Other: _____

Other: _____

1.11 RECEIVING WATERS:

Receiving waters must be depicted on the Environmental Layout Sheets in Attachment 1.2 of this SWP3. Include Segment # for receiving waters.

Tributaries	Classified Waterbody

* Add (*) for impaired waterbodies with pollutant in ().

1.12 ROLES AND RESPONSIBILITIES: TxDOT

- Development of plans and specifications
- Perform SWP3 inspections
- Maintain SWP3 records and update to reflect daily operations
- Other: _____

Other: _____

1.13 ROLES AND RESPONSIBILITIES: CONTRACTOR

- Day To Day Operational Control
- Maintain schedule of major construction activities
- Install, maintain and modify BMPs
- Other: _____

Other: _____

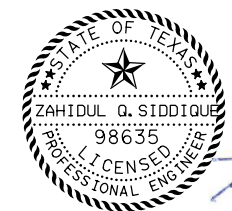

Zahidul Q. Siddique
5/16/2024

**STORMWATER POLLUTION PREVENTION PLAN (SWP3)
(Less Than 1 Acre)**

FED. RD. DIV. NO.	PROJECT NO.			SHEET NO.
				37
STATE	STATE DIST.	COUNTY		
TEXAS	TYL	SMITH, ETC		
CONT.	SECT.	JOB	HIGHWAY NO.	
0910	16	180	SH 64, ETC	

DISCLAIMER: The use of this standard is governed by the "Texas Engineering Practice Act". No warranty of any kind is made by TxDOT for any purpose whatsoever. TxDOT assumes no responsibility for the conversion of this standard to other formats or for incorrect results or damages resulting from its use.

DATE: FILE:

I. STORMWATER POLLUTION PREVENTION-CLEAN WATER ACT SECTION 402

TPDES TXR 150000: Stormwater Discharge Permit or Construction General Permit required for projects with 1 or more acres disturbed soil. Projects with any disturbed soil must protect for erosion and sedimentation in accordance with Item 506.

List MS4 Operator(s) that may receive discharges from this project. They may need to be notified prior to construction activities.

- 1.
2. No Action Required Required Action

Action No.

1. Prevent stormwater pollution by controlling erosion and sedimentation in accordance with TPDES Permit TXR 150000
2. Comply with the SW3P and revise when necessary to control pollution or required by the Engineer.
3. Post Construction Site Notice (CSN) with SW3P information on or near the site, accessible to the public and TCEQ, EPA or other inspectors.
4. When Contractor project specific locations (PSL's) increase disturbed soil area to 5 acres or more, submit NOI to TCEQ and the Engineer.

II. WORK IN OR NEAR STREAMS, WATERBODIES AND WETLANDS CLEAN WATER ACT SECTIONS 401 AND 404

USACE Permit required for filling, dredging, excavating or other work in any water bodies, rivers, creeks, streams, wetlands or wet areas.

The Contractor must adhere to all of the terms and conditions associated with the following permit(s):

- No Permit Required
- Nationwide Permit 14 - PCN not Required (less than 1/10th acre waters or wetlands affected)
- Nationwide Permit 14 - PCN Required (1/10 to <1/2 acre, 1/3 in tidal waters)
- Individual 404 Permit Required
- Other Nationwide Permit Required: NWP# _____

Required Actions: List waters of the US permit applies to, location in project and check Best Management Practices planned to control erosion, sedimentation and post-project TSS.

- 1.
- 2.
- 3.
- 4.

The elevation of the ordinary high water marks of any areas requiring work to be performed in the waters of the US requiring the use of a nationwide permit can be found on the Bridge Layouts.

Best Management Practices:

Erosion	Sedimentation	Post-Construction TSS
<input checked="" type="checkbox"/> Temporary Vegetation	<input checked="" type="checkbox"/> Silt Fence	<input checked="" type="checkbox"/> Vegetative Filter Strips
<input type="checkbox"/> Blankets/Matting	<input type="checkbox"/> Rock Berm	<input type="checkbox"/> Retention/Irrigation Systems
<input type="checkbox"/> Mulch	<input type="checkbox"/> Triangular Filter Dike	<input type="checkbox"/> Extended Detention Basin
<input type="checkbox"/> Sodding	<input type="checkbox"/> Sand Bag Berm	<input type="checkbox"/> Constructed Wetlands
<input type="checkbox"/> Interceptor Swale	<input type="checkbox"/> Straw Bale Dike	<input type="checkbox"/> Wet Basin
<input type="checkbox"/> Diversion Dike	<input type="checkbox"/> Brush Berms	<input type="checkbox"/> Erosion Control Compost
<input type="checkbox"/> Erosion Control Compost	<input type="checkbox"/> Erosion Control Compost	<input type="checkbox"/> Mulch Filter Berm and Socks
<input type="checkbox"/> Mulch Filter Berm and Socks	<input type="checkbox"/> Mulch Filter Berm and Socks	<input type="checkbox"/> Compost Filter Berm and Socks
<input type="checkbox"/> Compost Filter Berm and Socks	<input type="checkbox"/> Compost Filter Berm and Socks	<input type="checkbox"/> Vegetation Lined Ditches
	<input type="checkbox"/> Stone Outlet Sediment Traps	<input type="checkbox"/> Sand Filter Systems
	<input type="checkbox"/> Sediment Basins	<input type="checkbox"/> Grassy Swales

III. CULTURAL RESOURCES

Refer to TxDOT Standard Specifications in the event historical issues or archeological artifacts are found during construction. Upon discovery of archeological artifacts (bones, burnt rock, flint, pottery, etc.) cease work in the immediate area and contact the Engineer immediately.

- No Action Required Required Action

Action No.

- 1.
- 2.
- 3.
- 4.

IV. VEGETATION RESOURCES

Preserve native vegetation to the extent practical. Contractor must adhere to Construction Specification Requirements Specs 162, 164, 192, 193, 506, 730, 751, 752 in order to comply with requirements for invasive species, beneficial landscaping, and tree/brush removal commitments.

- No Action Required Required Action

Action No.

- 1.
- 2.
- 3.
- 4.

V. FEDERAL LISTED, PROPOSED THREATENED, ENDANGERED SPECIES, CRITICAL HABITAT, STATE LISTED SPECIES, CANDIDATE SPECIES AND MIGRATORY BIRDS.

- No Action Required Required Action

Action No.

1. Adhere to Migratory Bird Treaty Act.
- 2.
- 3.
- 4.

If any of the listed species are observed, cease work in the immediate area, do not disturb species or habitat and contact the Engineer immediately. The work may not remove active nests from bridges and other structures during nesting season of the birds associated with the nests. If caves or sinkholes are discovered, cease work in the immediate area, and contact the Engineer immediately.

LIST OF ABBREVIATIONS

BMP: Best Management Practice	SPCC: Spill Prevention Control and Countermeasure
CGP: Construction General Permit	SW3P: Storm Water Pollution Prevention Plan
DSHS: Texas Department of State Health Services	PCN: Pre-Construction Notification
FHWA: Federal Highway Administration	PSL: Project Specific Location
MOA: Memorandum of Agreement	TCEQ: Texas Commission on Environmental Quality
MOU: Memorandum of Understanding	TPDES: Texas Pollutant Discharge Elimination System
MS4: Municipal Separate Stormwater Sewer System	TPWD: Texas Parks and Wildlife Department
MBTA: Migratory Bird Treaty Act	TxDOT: Texas Department of Transportation
NOT: Notice of Termination	T&E: Threatened and Endangered Species
NWP: Nationwide Permit	USACE: U.S. Army Corps of Engineers
NOI: Notice of Intent	USFWS: U.S. Fish and Wildlife Service

VI. HAZARDOUS MATERIALS OR CONTAMINATION ISSUES

General (applies to all projects):

Comply with the Hazard Communication Act (the Act) for personnel who will be working with hazardous materials by conducting safety meetings prior to beginning construction and making workers aware of potential hazards in the workplace. Ensure that all workers are provided with personal protective equipment appropriate for any hazardous materials used.

Obtain and keep on-site Material Safety Data Sheets (MSDS) for all hazardous products used on the project, which may include, but are not limited to the following categories: Paints, acids, solvents, asphalt products, chemical additives, fuels and concrete curing compounds or additives. Provide protected storage, off bare ground and covered, for products which may be hazardous. Maintain product labelling as required by the Act.

Maintain an adequate supply of on-site spill response materials, as indicated in the MSDS. In the event of a spill, take actions to mitigate the spill as indicated in the MSDS, in accordance with safe work practices, and contact the District Spill Coordinator immediately. The Contractor shall be responsible for the proper containment and cleanup of all product spills.

Contact the Engineer if any of the following are detected:

- * Dead or distressed vegetation (not identified as normal)
- * Trash piles, drums, canister, barrels, etc.
- * Undesirable smells or odors
- * Evidence of leaching or seepage of substances

Does the project involve any bridge class structure rehabilitation or replacements (bridge class structures not including box culverts)?

- Yes No

If "No", then no further action is required.

If "Yes", then TxDOT is responsible for completing asbestos assessment/inspection.

Are the results of the asbestos inspection positive (is asbestos present)?

- Yes No

If "Yes", then TxDOT must retain a DSHS licensed asbestos consultant to assist with the notification, develop abatement/mitigation procedures, and perform management activities as necessary. The notification form to DSHS must be postmarked at least 15 working days prior to scheduled demolition.

If "No", then TxDOT is still required to notify DSHS 15 working days prior to any scheduled demolition.

In either case, the Contractor is responsible for providing the date(s) for abatement activities and/or demolition with careful coordination between the Engineer and asbestos consultant in order to minimize construction delays and subsequent claims.

Any other evidence indicating possible hazardous materials or contamination discovered on site. Hazardous Materials or Contamination Issues Specific to this Project:

- No Action Required Required Action

Action No.

- 1.
- 2.
- 3.

VII. OTHER ENVIRONMENTAL ISSUES

(includes regional issues such as Edwards Aquifer District, etc.)

- No Action Required Required Action

Action No.

- 1.
- 2.
- 3.

 © 2024 Texas Department of Transportation		Design Division Standard		
ENVIRONMENTAL PERMITS, ISSUES AND COMMITMENTS EPIC				
FILE: epic.dgn	DN: TxDOT	CK: RG	DW: VP	CK: AR
© TxDOT: February 2015	CONT	SECT	JOB	HIGHWAY
12-12-2011 (DS) REVISIONS	0910	16	180	SH 64, Etc.
05-07-14 ADDED NOTE SECTION IV. TO ITEM 506, ADDED GRASSY SWALES.	DIST	COUNTY	SHEET NO.	
	TYL	Smith, Etc.	38	

CK
DW
CK
DN

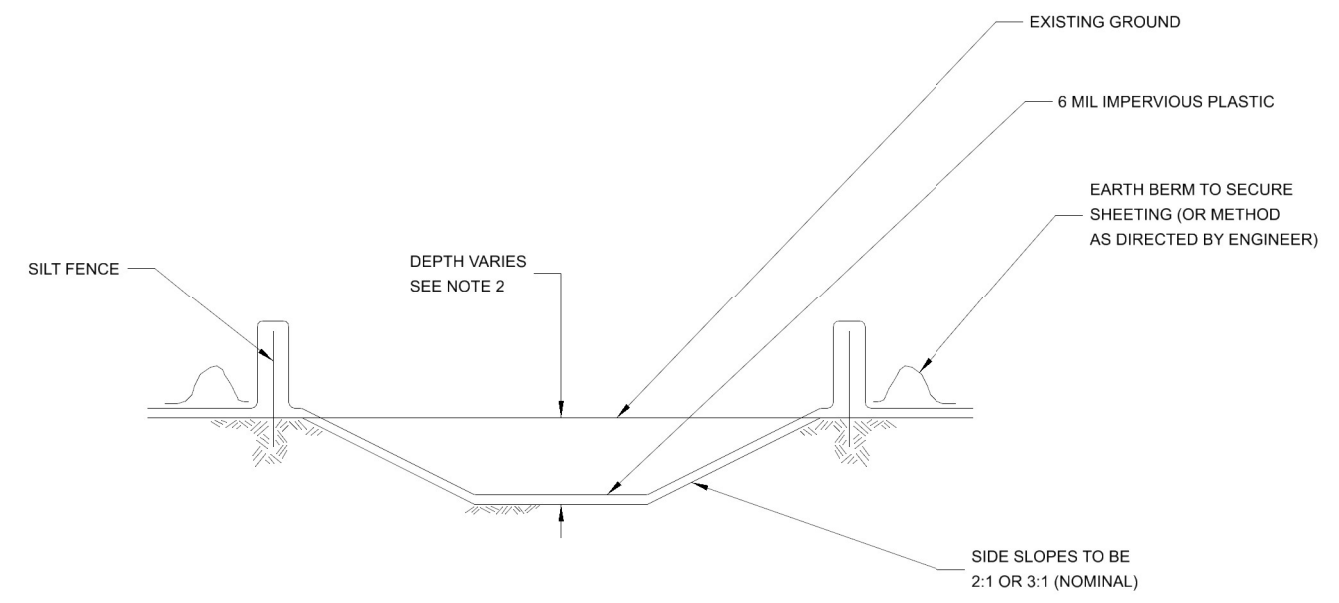
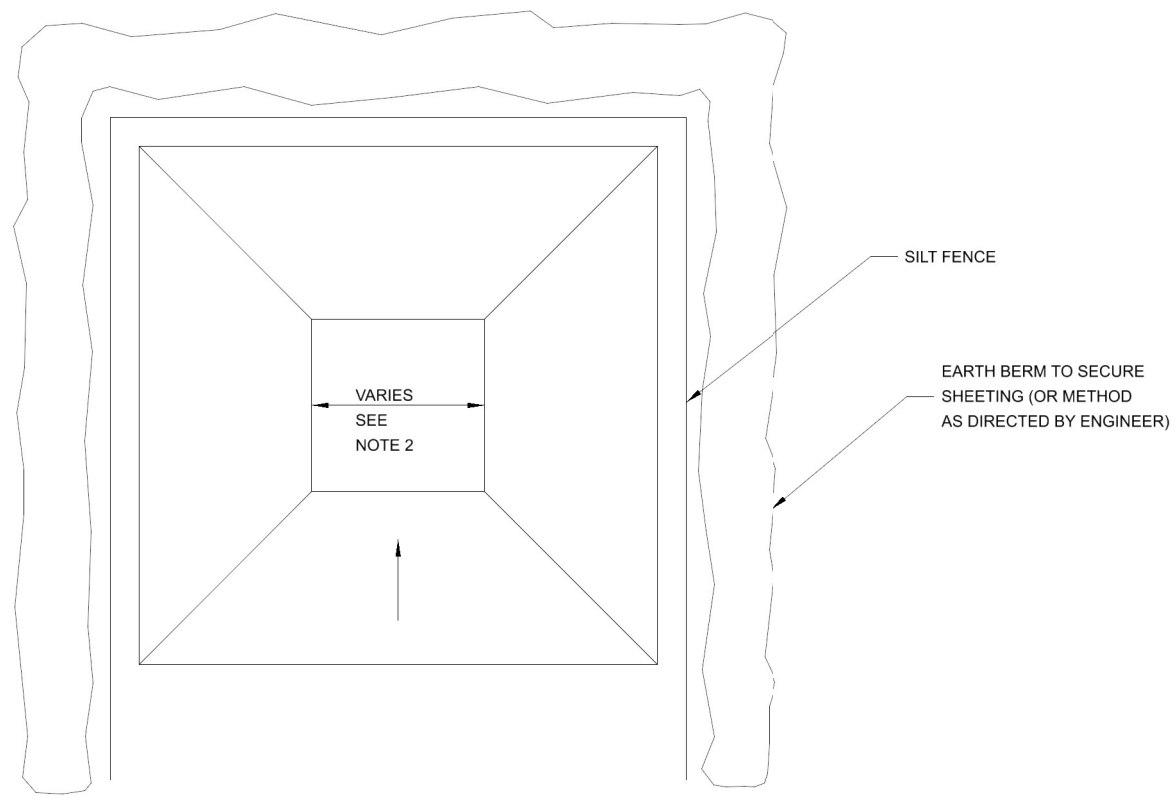

CONCRETE WASHOUT AREA
NOT TO SCALE
(SEE NOTE 2)

NOTES

1. CONCRETE WASHOUT AREA(S) SHALL BE INSTALLED PRIOR TO CONCRETE PLACEMENT ON SITE. THE CONCRETE WASHOUT AREA SHALL BE ENTIRELY SELF-CONTAINED.
2. THE CONTRACTOR SHALL SUBMIT THE DESIGN, LOCATION AND SIZING OF THE CONCRETE WASHOUT AREA(S) WITH THE PROJECT'S EROSION AND SEDIMENTATION CONTROL PLAN AND SHALL BE APPROVED BY THE ENGINEER.

LOCATION: WASHOUT AREA(S) ARE TO BE LOCATED AT LEAST 50 FEET FROM ANY STREAM, WETLAND, STORM DRAINS, OR OTHER SENSITIVE RESOURCE. THE FLOOD CONTINGENCY PLAN MUST ADDRESS THE CONCRETE WASHOUT IF THE WASHOUT IS TO BE LOCATED WITHIN THE FLOODPLAN.

SIZE: THE WASHOUT MUST HAVE SUFFICIENT VOLUME TO CONTAIN ALL LIQUID AND CONCRETE WASTE GENERATED BY WASHOUT OPERATIONS INCLUDING, BUT NOT LIMITED TO, OPERATIONS ASSOCIATED WITH GROUT AND MORTAR.
3. SURFACE DISCHARGE IS UNACCEPTABLE, THEREFORE EARTH BERM OR OTHER CONTROL MEASURES, AS APPROVED BY THE ENGINEER, SHOULD BE USED AROUND THE PERIMETER OF THE CONCRETE WASHOUT AREA FOR CONTAINMENT.
4. SIGNS SHOULD BE PLACED AT THE CONSTRUCTION ENTRANCE, AT THE CONCRETE AREA(S) AND ELSEWHERE AS NECESSARY TO CLEARLY INDICATE THE LOCATION OF THE CONCRETE WASHOUT TO OPERATORS OF CONCRETE TRUCKS AND PUMP RIGS. WASHOUT AREA(S) SHOULD BE FLAGGED WITH SAFETY FENCING OR OTHER APPROVED METHOD.
5. CONCRETE WASH-OUT AREAS SHALL BE LINED WITH IMPERVIOUS PLASTIC WITH A MINIMUM THICKNESS OF 6 MILS AND BE REPLACED IF DAMAGED DURING CLEAN-OUT OF HARDENED CONCRETE FROM THE WASH-OUT AREA.
6. WASHOUT AREA(S) ARE TO BE INSPECTED AT LEAST ONCE A WEEK FOR STRUCTURAL INTEGRITY, ADEQUATE HOLDING CAPACITY AND CHECKED FOR LEAKS, TEARS, OR OVERFLOWS. (AS DIRECTED BY THE CONSTRUCTION SITE ENVIRONMENTAL INSPECTION REPORT) WASHOUT AREA(S) SHOULD BE CHECKED AFTER HEAVY RAINS.
7. HARDENED CONCRETE WASTE SHOULD BE REMOVED AND DISPOSED OF WHEN THE WASTE HAS ACCUMULATED TO HALF OF THE CONCRETE WASHOUT'S HEIGHT. THE WASTE CAN BE STORED AT AN UPLAND LOCATION, AS APPROVED BY THE ENGINEER. ALL CONCRETE WASTE SHALL BE DISPOSED OF IN A MANNER CONSISTENT WITH ALL APPLICABLE LAWS, REGULATIONS, AND GUIDELINES.
8. PAYMENT FOR THIS ITEM IS TO BE INCLUDED UNDER THE GENERAL COST OF THE WORK FOR THE PROJECT, INCLUDING SITE RESTORATION.

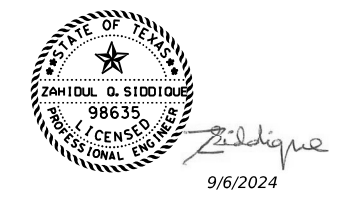

CONCRETE WASHOUT
DETAIL

© TxDOT 2024 SHEET 1 OF 1

CONT	SECT	JOB	HIGHWAY
0910	16	180	SH 64, Etc.
DIST	COUNTY	SHEET NO.	
TYL	SMITH, Etc.	38A	

DATE: 9/6/2024 9:18:18 AM
FILE: c:\pw\infotech\zahidul.siddique\dms43123\CONC WASHOUT DETAIL_001.dgn

DISCLAIMER: This standard is governed by the "Texas Engineering Practice Act". No warranty of any kind is made by TxDOT for any purpose whatsoever. TxDOT assumes no responsibility for the conversion of this standard to other formats or for incorrect results or damages resulting from its use.

DATE: 5/16/2024
 FILE: c:\pwr-infratech\in.zhang\dms47076\ec916.dgn

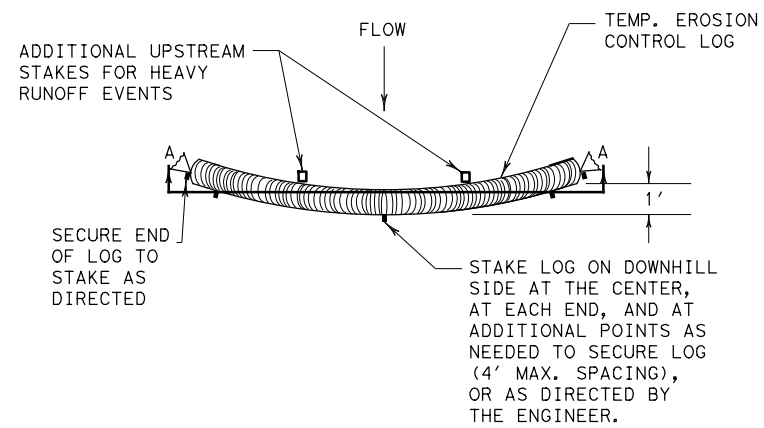

PLAN VIEW

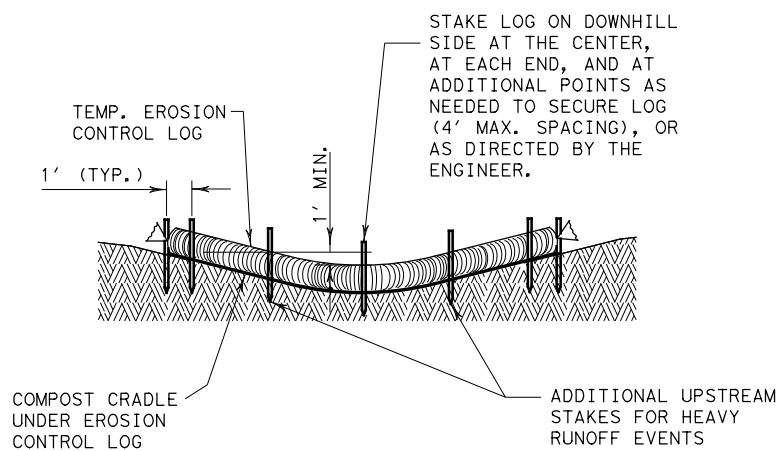

SECTION A-A

EROSION CONTROL LOG DAM

CL-D

LEGEND

- CL-D EROSION CONTROL LOG DAM
- CL-BOC EROSION CONTROL LOG AT BACK OF CURB
- CL-ROW EROSION CONTROL LOG AT EDGE OF RIGHT-OF-WAY
- CL-SST EROSION CONTROL LOGS ON SLOPES STAKE AND TRENCHING ANCHORING
- CL-SSL EROSION CONTROL LOGS ON SLOPES STAKE AND LASHING ANCHORING
- CL-DI EROSION CONTROL LOG AT DROP INLET
- CL-CI EROSION CONTROL LOG AT CURB INLET
- CL-GI EROSION CONTROL LOG AT CURB & GRATE INLET

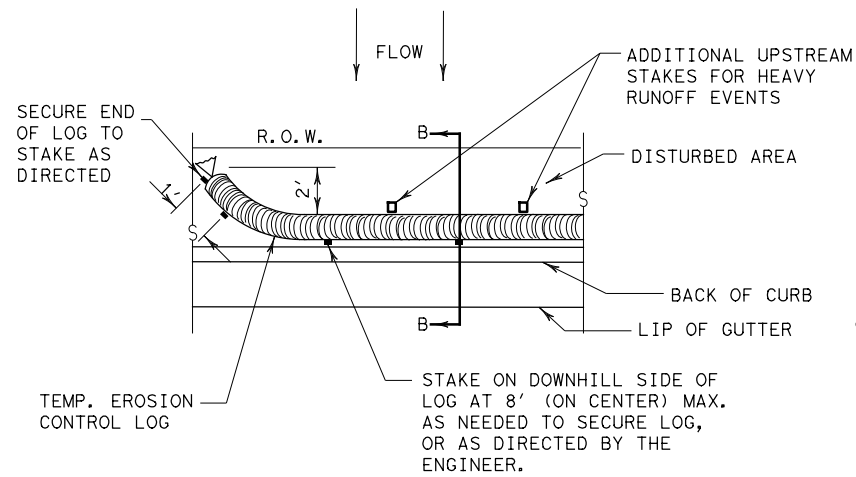

PLAN VIEW

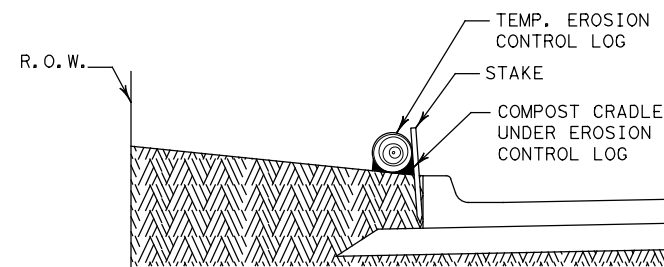

SECTION B-B

EROSION CONTROL LOG AT BACK OF CURB

CL-BOC

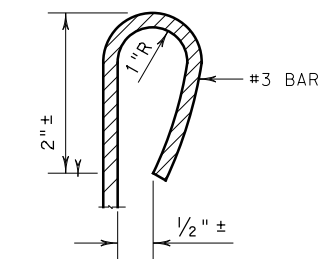

REBAR STAKE DETAIL

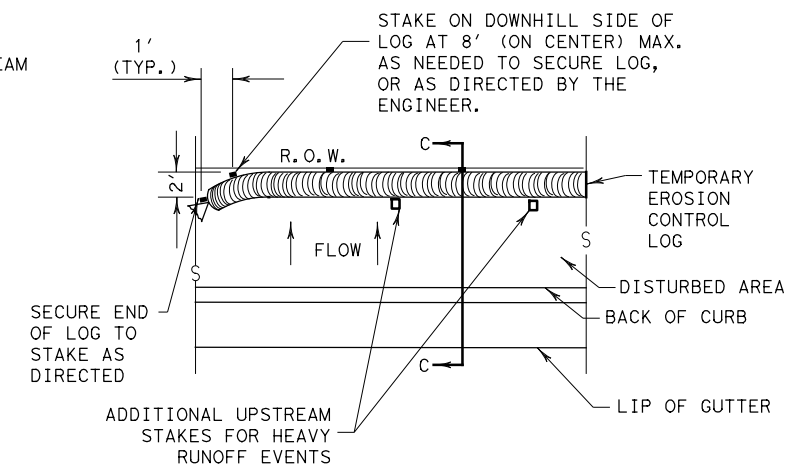

PLAN VIEW

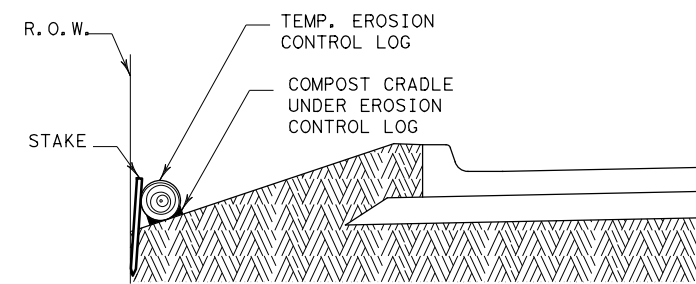

SECTION C-C

EROSION CONTROL LOG AT EDGE OF RIGHT-OF-WAY

CL-ROW

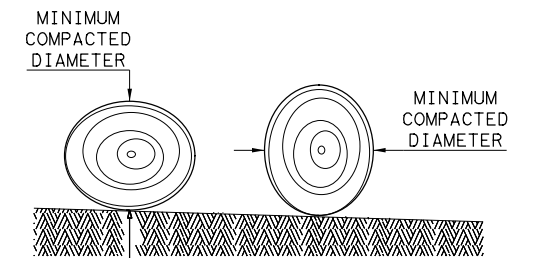

DIAMETER MEASUREMENTS OF EROSION CONTROL LOGS SPECIFIED IN PLANS

SEDIMENT BASIN & TRAP USAGE GUIDELINES

An erosion control log sediment trap may be used to filter sediment out of runoff draining from an unstabilized area.

Log Traps: The drainage area for a sediment trap should not exceed 5 acres. The trap capacity should be 1800 CF/Acre (0.5" over the drainage area).

Control logs should be placed in the following locations:

1. Within drainage ditches spaced as needed or min. 500' on center
2. Immediately preceding ditch inlets or drain inlets
3. Just before the drainage enters a water course
4. Just before the drainage leaves the right of way
5. Just before the drainage leaves the construction limits where drainage flows away from the project.

The logs should be cleaned when the sediment has accumulated to a depth of 1/2 the log diameter.

Cleaning and removal of accumulated sediment deposits is incidental and will not be paid for separately.

GENERAL NOTES:

1. EROSION CONTROL LOGS SHALL BE INSTALLED IN ACCORDANCE WITH MANUFACTURER'S RECOMMENDATIONS, OR AS DIRECTED BY THE ENGINEER.
2. LENGTHS OF EROSION CONTROL LOGS SHALL BE IN ACCORDANCE WITH MANUFACTURER'S RECOMMENDATIONS AND AS REQUIRED FOR THE PURPOSE INTENDED.
3. UNLESS OTHERWISE DIRECTED, USE BIODEGRADABLE OR PHOTODEGRADABLE CONTAINMENT MESH ONLY WHERE LOG WILL REMAIN IN PLACE AS PART OF A VEGETATIVE SYSTEM. FOR TEMPORARY INSTALLATIONS, USE RECYCLABLE CONTAINMENT MESH.
4. FILL LOGS WITH SUFFICIENT FILTER MATERIAL TO ACHIEVE THE MINIMUM COMPACTED DIAMETER SPECIFIED IN THE PLANS WITHOUT EXCESSIVE DEFORMATION.
5. STAKES SHALL BE 2" X 2" WOOD OR #3 REBAR, 2'-4' LONG, EMBEDDED SUCH THAT 2" PROTRUDES ABOVE LOG, OR AS DIRECTED BY THE ENGINEER.
6. DO NOT PLACE STAKES THROUGH CONTAINMENT MESH.
7. COMPOST CRADLE MATERIAL IS INCIDENTAL & WILL NOT BE PAID FOR SEPARATELY.
8. SANDBAGS USED AS ANCHORS SHALL BE PLACED ON TOP OF LOGS & SHALL BE OF SUFFICIENT SIZE TO HOLD LOGS IN PLACE.
9. TURN THE ENDS OF EACH ROW OF LOGS UPSLOPE TO PREVENT RUNOFF FROM FLOWING AROUND THE LOG.
10. FOR HEAVY RUNOFF EVENTS, ADDITIONAL UPSTREAM STAKES MAY BE NECESSARY TO KEEP LOG FROM FOLDING IN ON ITSELF.

SHEET 1 OF 3

		Design Division Standard	
TEMPORARY EROSION, SEDIMENT AND WATER POLLUTION CONTROL MEASURES			
EROSION CONTROL LOG			
EC (9) - 16			
FILE: ec916	DN: TxDOT	CK: KM	DW: LS/PT
© TxDOT: JULY 2016	CONT SECT	JOB	HIGHWAY
REVISIONS	091016	180	SH 64, Etc.
	DIST	COUNTY	SHEET NO.
	TYL	SMITH, Etc.	39

DISCLAIMER:
 The use of this standard is governed by the "Texas Engineering Practice Act". No warranty of any kind is made by TxDOT for any purpose whatsoever. TxDOT assumes no responsibility for the conversion of this standard to other formats or for incorrect results or damages resulting from its use.

DATE: 5/16/2024
 FILE: c:\pw\infratech\in.zhang\dms47076\ec916.dgn

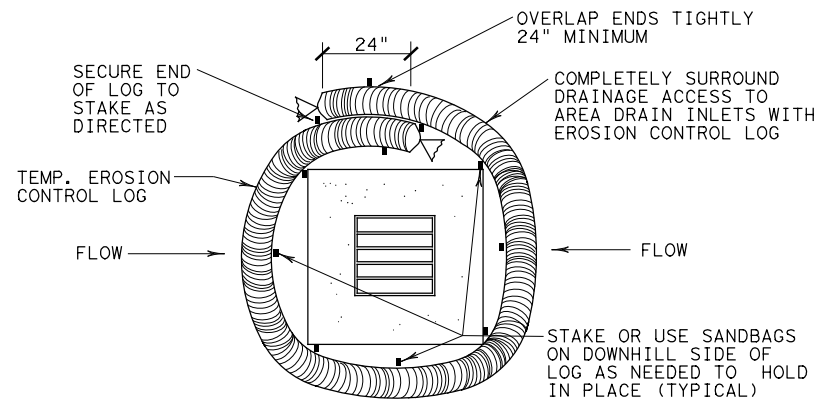

EROSION CONTROL LOG AT DROP INLET

CL-DI

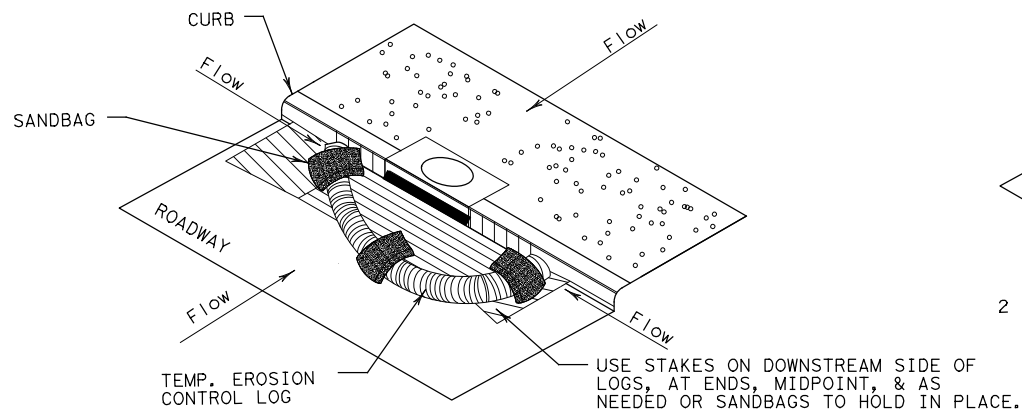

EROSION CONTROL LOG AT CURB INLET

CL-CI

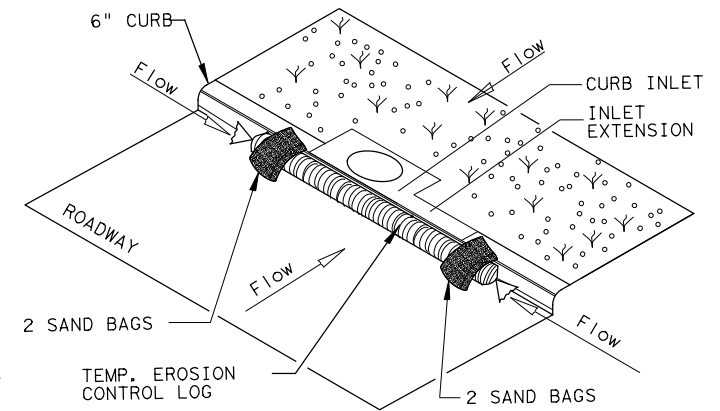

EROSION CONTROL LOG AT CURB INLET

CL-CI

NOTE:
 EROSION CONTROL LOGS USED AT CURB INLETS SHOULD ONLY BE USED IF THEY WILL NOT IMPEDE TRAFFIC OR FLOOD THE ROADWAY OR WHEN THE STORM SEWER SYSTEM IS NOT FULLY FUNCTIONAL.

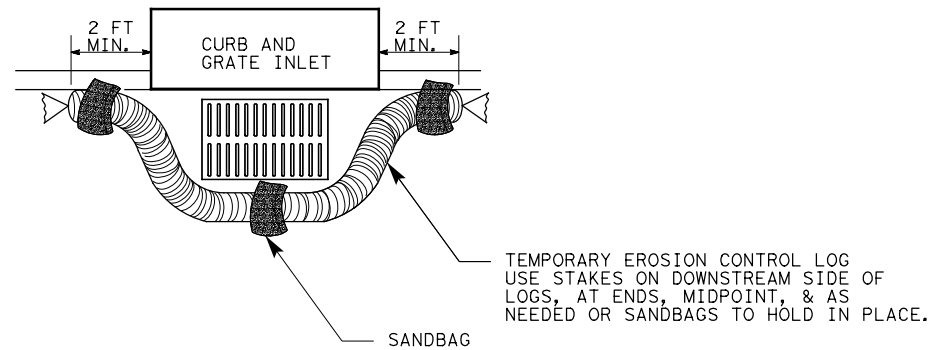

EROSION CONTROL LOG AT CURB & GRADE INLET

CL-GI

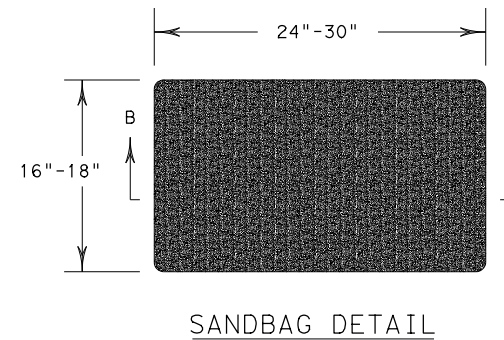
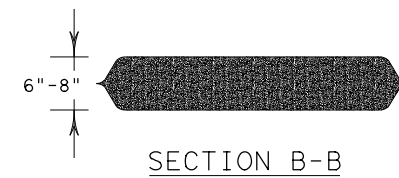

SHEET 3 OF 3

		Design Division Standard	
TEMPORARY EROSION, SEDIMENT AND WATER POLLUTION CONTROL MEASURES EROSION CONTROL LOG EC (9) - 16			
FILE: ec916	DN: TxDOT	CK: KM	DW: LS/PT
© TxDOT: JULY 2016	CONT	SECT	JOB
REVISIONS	0910	16	180
DIST	COUNTY	SH	SHEET NO.
TYL	SMITH, E+c.	64	40

DISCLAIMER: The use of this standard is governed by the "Texas Engineering Practice Act". No warranty of any kind is made by TxDOT for any purpose whatsoever. TxDOT assumes no responsibility for the conversion of this standard to other formats or for incorrect results or damages resulting from its use.

DATE: 5/16/2024
 FILE: c:\pw\infratech\in.zhang\dms47076\ec916.dgn

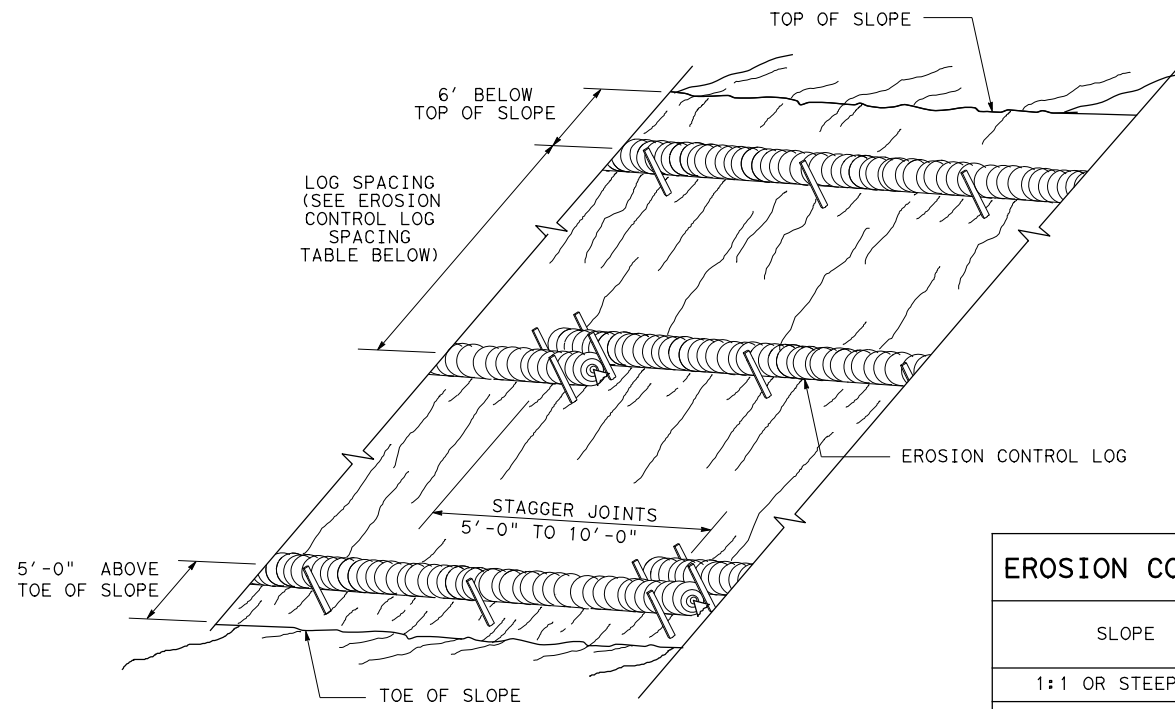

**EROSION CONTROL LOGS ON SLOPES
 STAKE AND TRENCHING ANCHORING**

CL-SST

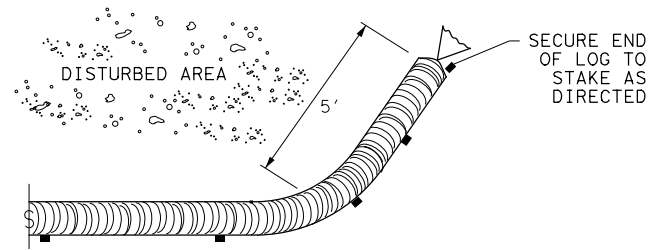

END SECTION RAP DETAIL

SLOPE	LOG DIAMETER			
	6"	8"	12"	18"
1:1 OR STEEPER	5'	10'	15'	20'
2:1	10'	20'	30'	40'
3:1	15'	30'	45'	60'
4:1 OR FLATTER	20'	40'	60'	80'

* ADJUSTMENTS CAN BE MADE FOR SOIL TYPE:
 SOFT, LOAMY SOILS-ADJUST ROWS CLOSER TOGETHER;
 HARD, ROCKY SOILS- ADJUST ROWS FARTHER APART

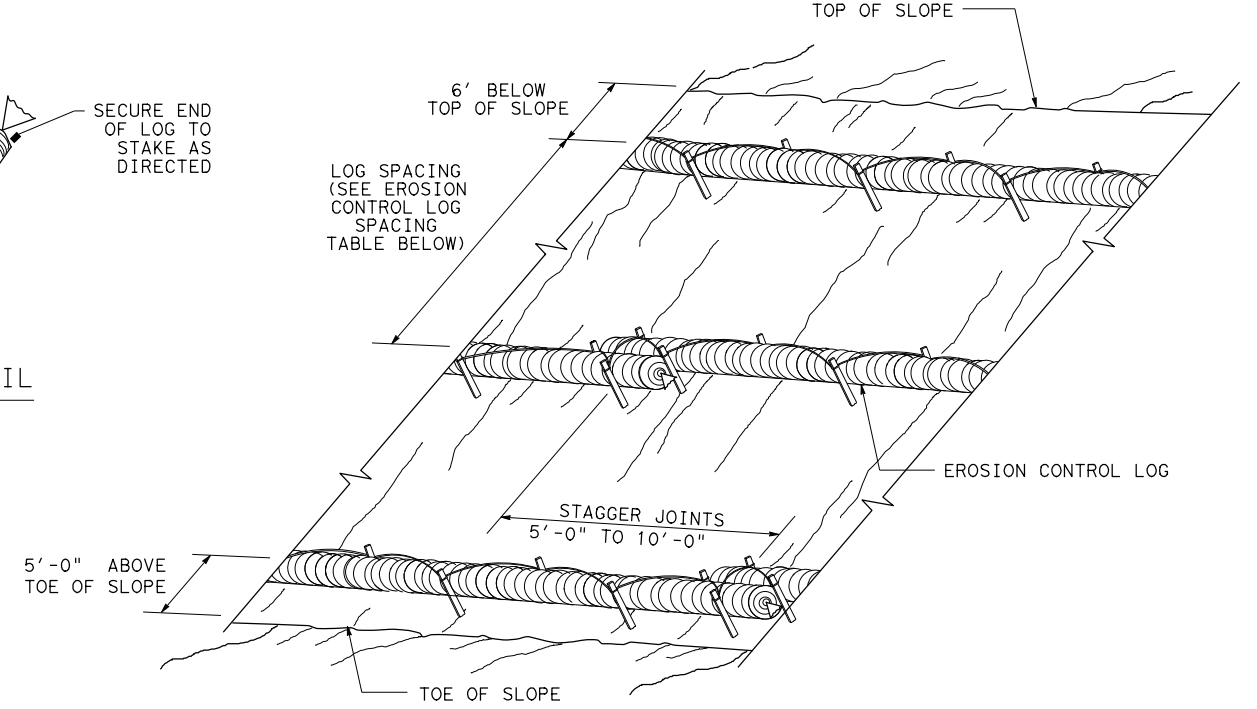

**EROSION CONTROL LOGS ON SLOPES
 STAKE AND LASHING ANCHORING**

CL-SSL

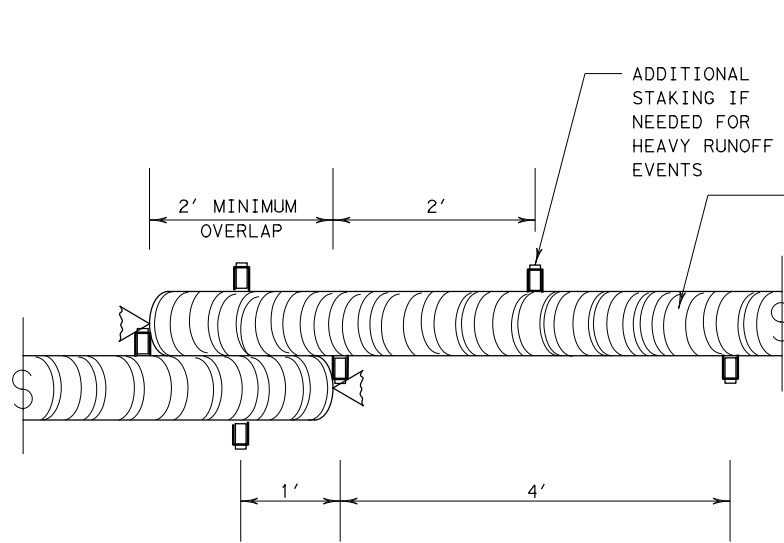

STAKE AND TRENCHING ANCHORING DETAIL

CL-SST

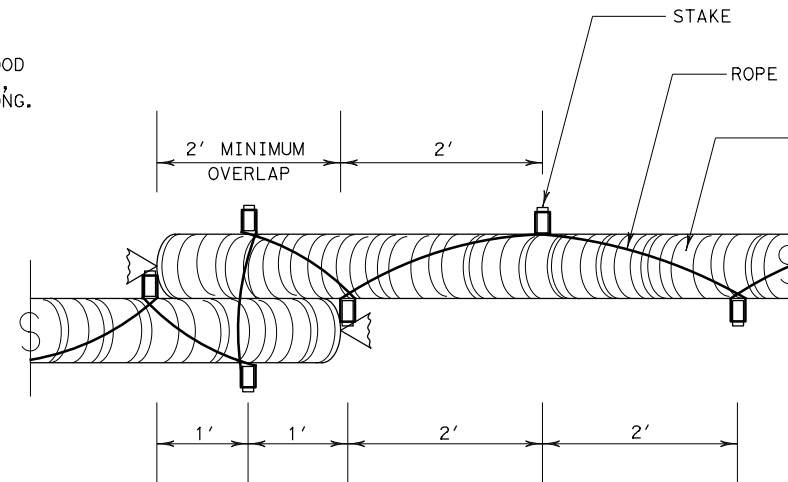
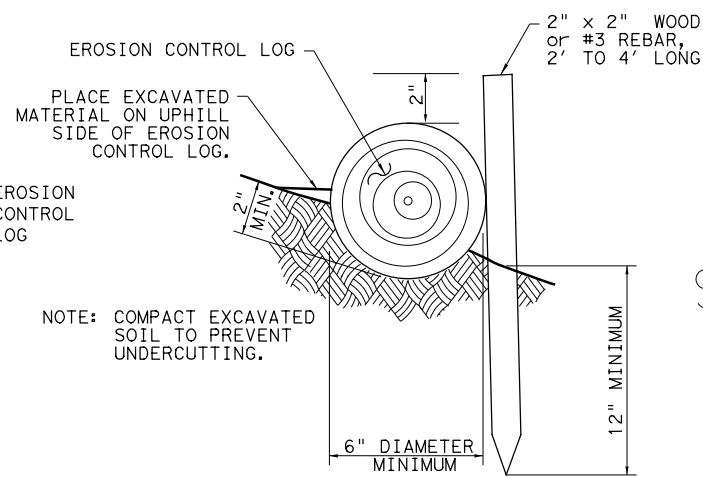

STAKE AND LASHING ANCHORING DETAIL

CL-SSL

LOG DIAMETER	DEPTH
6"	2"
8"	3"
12"	4"
18"	5"

TRENCH DEPTH TABLE

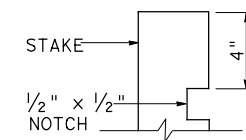

STAKE NOTCH DETAIL

SHEET 2 OF 3

		Design Division Standard	
TEMPORARY EROSION, SEDIMENT AND WATER POLLUTION CONTROL MEASURES EROSION CONTROL LOG EC (9) - 16			
FILE: ec116	DN: TxDOT	CK: KM	DW: LS/PT
© TxDOT: JULY 2016	CONT SECT	JOB	HIGHWAY
REVISIONS	0910 16	180	SH 64, Etc.
	DIST	COUNTY	SHEET NO.
	TYL	SMITH, Etc.	41