

Control	0168-07-043, ETC.
Project	C 168-7-43, ETC.
Highway	US 60
County	DEAF SMITH

ADDENDUM ACKNOWLEDGMENT

Each bidder is required to acknowledge receipt of an addendum issued for a specific project. This page is provided for the purpose of acknowledging an addendum.

FAILURE TO ACKNOWLEDGE RECEIPT OF AN ADDENDUM WILL RESULT IN THE BID NOT BEING READ.

In order to properly acknowledge an addendum place a mark in the box next to the respective addendum.

- ADDENDUM NO. 1
- ADDENDUM NO. 2
- ADDENDUM NO. 3
- ADDENDUM NO. 4
- ADDENDUM NO. 5

In addition, the bidder by affixing their signature to the signature page of the proposal is acknowledging that they have taken the addendum(s) into consideration when preparing their bid and that the information contained in the addendum will be included in the contract, if awarded by the Commission or other designees.

This page intentionally left blank.

Control	0168-07-043, ETC.
Project	C 168-7-43, ETC.
Highway	US 60
County	DEAF SMITH

PROPOSAL TO THE TEXAS TRANSPORTATION COMMISSION

2014 SPECIFICATIONS

WORK CONSISTING OF REHABILITATE EXISTING ROADWAY DEAF SMITH COUNTY, TEXAS

The quantities in the proposal are approximate. The quantities of work and materials may be increased or decreased as considered necessary to complete the work as planned and contemplated.

This project is to be completed in 599 working days and will be accepted when fully completed and finished to the satisfaction of the Executive Director or designee.

Provide a proposal guaranty in the form of a Cashier's Check, Teller's Check (including an Official Check) or Bank Money Order on a State or National Bank or Savings and Loan Association, or State or Federally chartered Credit Union made payable to the Texas Transportation Commission in the following amount:

ONE HUNDRED THOUSAND (Dollars) (\$100,000)

A bid bond may be used as the required proposal guaranty. The bond form may be detached from the proposal for completion. The proposal may not be disassembled to remove the bond form. The bond must be in accordance with Item 2 of the specifications.

Any addenda issued amending this proposal and/or the plans that have been acknowledged by the bidder, become part of this proposal.

By signing the proposal the bidder certifies:

1. the only persons or parties interested in this proposal are those named and the bidder has not directly or indirectly participated in collusion, entered into an agreement or otherwise taken any action in restraint of free competitive bidding in connection with the above captioned project.
2. in the event of the award of a contract, the organization represented will secure bonds for the full amount of the contract.
3. the signatory represents and warrants that they are an authorized signatory for the organization for which the bid is submitted and they have full and complete authority to submit this bid on behalf of their firm.
4. that the certifications and representations contained in the proposal are true and accurate and the bidder intends the proposal to be taken as a genuine government record.

• **Signed:** **

(1) _____ (2) _____ (3) _____

Print Name:

(1) _____ (2) _____ (3) _____

Title:

(1) _____ (2) _____ (3) _____

Company:

(1) _____ (2) _____ (3) _____

- Signatures to comply with Item 2 of the specifications.

**Note: Complete (1) for single venture, through (2) for joint venture and through (3) for triple venture.

* **When the working days field contains an asterisk (*) refer to the Special Provisions and General Notes.**

NOTICE TO CONTRACTORS

ANY CONTRACTORS INTENDING TO BID ON ANY WORK TO BE AWARDED BY THIS DEPARTMENT MUST SUBMIT A SATISFACTORY “AUDITED FINANCIAL STATEMENT” AND “EXPERIENCE QUESTIONNAIRE” AT LEAST TEN DAYS PRIOR TO THE LETTING DATE.

UNIT PRICES MUST BE SUBMITTED IN ACCORDANCE WITH ITEM 2 OF THE STANDARD SPECIFICATIONS OR SPECIAL PROVISION TO ITEM 2 FOR EACH ITEM LISTED IN THIS PROPOSAL.

TEXAS DEPARTMENT OF TRANSPORTATION

BID BOND

KNOW ALL PERSONS BY THESE PRESENTS,

That we, (Contractor Name) _____

Hereinafter called the Principal, and (Surety Name) _____

a corporation or firm duly authorized to transact surety business in the State of Texas, hereinafter called the Surety, are held and firmly bound unto the Texas Department of Transportation, hereinafter called the Oblige, in the sum of not less than two percent (2%) of the department's engineer's estimate, rounded to the nearest one thousand dollars, not to exceed one hundred thousand dollars (\$100,000) as a proposal guaranty (amount displayed on the cover of the proposal), the payment of which sum will and truly be made, the said Principal and the said Surety, bind ourselves, our heirs, executors, administrators, successors and assigns, jointly and severally, firmly by these presents.

WHEREAS, the principal has submitted a bid for the following project identified as:

Control	0168-07-043, ETC.
Project	C 168-7-43, ETC.
Highway	US 60
County	DEAF SMITH

NOW, THEREFORE, if the Oblige shall award the Contract to the Principal and the Principal shall enter into the Contract in writing with the Oblige in accordance with the terms of such bid, then this bond shall be null and void. If in the event of failure of the Principal to execute such Contract in accordance with the terms of such bid, this bond shall become the property of the Oblige, without recourse of the Principal and/or Surety, not as a penalty but as liquidated damages.

Signed this _____ Day of _____ 20_____

By: _____
(Contractor/Principal Name)

(Signature and Title of Authorized Signatory for Contractor/Principal)

*By: _____
(Surety Name)

(Signature of Attorney-in-Fact)

Impressed
Surety Seal
Only

*Attach Power of attorney (Surety) for Attorney-in-Fact

This form may be removed from the proposal.

This page intentionally left blank.

BIDDER'S CHECK RETURN

IMPORTANT

The space provided for the return address must be completed to facilitate the return of your bidder's check. Care must be taken to provide a legible, accurate, and complete return address, including zip code. A copy of this sheet should be used for each different return address.

NOTE

Successful bidders will receive their guaranty checks with the executed contract.

RETURN BIDDERS CHECK TO (PLEASE PRINT):

Control	0168-07-043, ETC.
Project	C 168-7-43, ETC.
Highway	US 60
County	DEAF SMITH

IMPORTANT

PLEASE RETURN THIS SHEET IN ITS ENTIRETY

Please acknowledge receipt of this check(s) at your earliest convenience by signing below in longhand, in ink, and returning this acknowledgement in the enclosed self addressed envelope.

Check Received By: _____ Date: _____

Title: _____

For (Contractor's Name): _____

Project _____ County _____

This page intentionally left blank.

NOTICE TO THE BIDDER

In the space provided below, please enter your total bid amount for this project. Only this figure will be read publicly by the Department at the public bid opening.

It is understood and agreed by the bidder in signing this proposal that the total bid amount entered below is not binding on either the bidder or the Department. It is further agreed that **the official total bid amount for this proposal will be determined by multiplying the unit bid prices for each pay item by the respective estimated quantities shown in this proposal and then totaling all of the extended amounts.**

\$ _____
Total Bid Amount

Control 0001-03-030
 Project STP 2000(938)HES
 Highway SH 20
 County EL PASO

ALT	ITEM	DESC	SP	Bid Item Description	Unit	Quantity	Bid Price	Amount	Seq
	I04	509	X	REMOV CONC (SDWLK)	MSY	266.400	\$10.000	\$2,664.00	1
						Total Bid Amount	\$2,664.00		

Signed _____
 Title _____
 Date _____

Additional Signature for Joint Venture:

Signed _____
 Title _____
 Date _____

EXAMPLE OF BID PRICES SUBMITTED BY COMPUTER PRINTOUT

EXAMPLE

EXAMPLE

EXAMPLE

EXAMPLE

EXAMPLES

BID PRICES SUBMITTED BY HAND WRITTEN FORMAT

ALT	ITEM-CODE			UNIT BID PRICE <u>ONLY</u> WRITTEN IN WORDS	UNIT	APPROX QUANTITIES	DEPT USE ONLY
	ITEM NO	DESC NO	S.P. NO.				
	190	026		RED OAK 1 1/2 - 1 3/4 GAL BB	EA	9.000	1
					L	E	

Unit price for each plant in place

	249	014		FLEX BASE(DEL)(DENSOT)(TY A GR4 CL2)	TON	56,787.00	14
					L	E	

Unit price for each ton of Flexible Base

	430	001	001	CL A CONC FOR EXT STR (CULV)	CY	45.000	27
					L	E	

Unit price for each cubic yard of Concrete

	610	007	001	RDWY ILL ASSEM(TY ST 50T-8-8)(.4 KW)S	EA	13.000	7
					L	E	

Unit price of each Roadway Illumination Assembly

EXAMPLE

EXAMPLE

EXAMPLE

EXAMPLE

This page intentionally left blank.

ALT	ITEM-CODE			UNIT BID PRICE ONLY. WRITTEN IN WORDS	UNIT	APPROX QUANTITIES	DEPT USE ONLY
	ITEM NO	DESC CODE	S.P. NO.				
	100	6011		PREPARING ROW(TREE)(24" TO 36" DIA.) DOLLARS and CENTS	EA	8.000	1
	104	6009		REMOVING CONC (RIPRAP) DOLLARS and CENTS	SY	2,919.000	2
	104	6017		REMOVING CONC (DRIVEWAYS) DOLLARS and CENTS	SY	2,124.000	3
	104	6022		REMOVING CONC (CURB AND GUTTER) DOLLARS and CENTS	LF	29,224.000	4
	104	6026		REMOVE CONC (GUTTER) DOLLARS and CENTS	LF	1,102.000	5
	104	6036		REMOVING CONC (SIDEWALK OR RAMP) DOLLARS and CENTS	SY	482.000	6
	110	6001		EXCAVATION (ROADWAY) DOLLARS and CENTS	CY	89,505.000	7
	132	6004		EMBANKMENT (FINAL)(DENS CONT)(TY B) DOLLARS and CENTS	CY	2,185.000	8
	162	6002		BLOCK SODDING DOLLARS and CENTS	SY	1,289.000	9
	164	6025		CELL FBR MLCH SEED(PERM)(URBAN)(SANDY) DOLLARS and CENTS	SY	13,908.000	10
	168	6001		VEGETATIVE WATERING DOLLARS and CENTS	MG	274.000	11

ALT	ITEM-CODE			UNIT BID PRICE ONLY. WRITTEN IN WORDS	UNIT	APPROX QUANTITIES	DEPT USE ONLY
	ITEM NO	DESC CODE	S.P. NO.				
	275	6001		CEMENT DOLLARS and CENTS	TON	1,957.000	12
	275	6010		CEMENT TREAT (SUBGRADE) (8") DOLLARS and CENTS	SY	147,866.000	13
	305	6003		SALV, HAUL & STKPL RCL APH PV (2 TO 4") DOLLARS and CENTS	SY	4,641.000	14
	305	6010		SLV, HAUL & STKPL RCL APH PV (8 TO 12") DOLLARS and CENTS	SY	149,424.000	15
	351	6012		FLEXIBLE PAVEMENT STRUCTURE REPAIR(2") DOLLARS and CENTS	SY	204.000	16
	360	6007	001	CONC PVMT (CONT REINF - CRCP) (13") DOLLARS and CENTS	SY	141,234.000	17
	360	6043	001	CONC PVMT (CONT REINF)(FAST TRK)(13") DOLLARS and CENTS	SY	6,576.000	18
	360	6046	001	CONC PVMT (CONT REINF-CRCP) (HES) (8") DOLLARS and CENTS	SY	1,983.000	19
	360	6047	001	CONC PVMT (CONT REINF - CRCP) (6") DOLLARS and CENTS	SY	12,149.000	20
	401	6001		FLOWABLE BACKFILL DOLLARS and CENTS	CY	2,754.000	21
	416	6004		DRILL SHAFT (36 IN) DOLLARS and CENTS	LF	58.000	22
	416	6006		DRILL SHAFT (48 IN) DOLLARS and CENTS	LF	22.000	23

ALT	ITEM-CODE			UNIT BID PRICE ONLY. WRITTEN IN WORDS	UNIT	APPROX QUANTITIES	DEPT USE ONLY
	ITEM NO	DESC CODE	S.P. NO.				
	432	6001		RIPRAP (CONC)(4 IN) DOLLARS and CENTS	CY	269.000	24
	432	6045		RIPRAP (MOW STRIP)(4 IN) DOLLARS and CENTS	CY	20.000	25
	450	6054	001	RAIL (TY SSTR) (W/DRAIN SLOTS) DOLLARS and CENTS	LF	100.000	26
	462	6001	002	CONC BOX CULV (3 FT X 2 FT) DOLLARS and CENTS	LF	1,362.000	27
	462	6003	002	CONC BOX CULV (4 FT X 2 FT) DOLLARS and CENTS	LF	656.000	28
	462	6006	002	CONC BOX CULV (5 FT X 2 FT) DOLLARS and CENTS	LF	929.000	29
	464	6003	001	RC PIPE (CL III)(18 IN) DOLLARS and CENTS	LF	97.000	30
	464	6005	001	RC PIPE (CL III)(24 IN) DOLLARS and CENTS	LF	2,983.000	31
	464	6010	001	RC PIPE (CL III)(48 IN) DOLLARS and CENTS	LF	22.000	32
	464	6012	001	RC PIPE (CL III)(60 IN) DOLLARS and CENTS	LF	32.000	33
	465	6013	001	INLET (COMPL)(PCO)(3FT)(NONE) DOLLARS and CENTS	EA	16.000	34
	465	6014	001	INLET (COMPL)(PCO)(3FT)(LEFT) DOLLARS and CENTS	EA	9.000	35

ALT	ITEM-CODE			UNIT BID PRICE ONLY. WRITTEN IN WORDS	UNIT	APPROX QUANTITIES	DEPT USE ONLY
	ITEM NO	DESC CODE	S.P. NO.				
	465	6015	001	INLET (COMPL)(PCO)(3FT)(RIGHT) DOLLARS and CENTS	EA	4.000	36
	465	6016	001	INLET (COMPL)(PCO)(3FT)(BOTH) DOLLARS and CENTS	EA	24.000	37
	465	6017	001	INLET (COMPL)(PCO)(4FT)(NONE) DOLLARS and CENTS	EA	2.000	38
	465	6018	001	INLET (COMPL)(PCO)(4FT)(LEFT) DOLLARS and CENTS	EA	1.000	39
	465	6019	001	INLET (COMPL)(PCO)(4FT)(RIGHT) DOLLARS and CENTS	EA	1.000	40
	465	6020	001	INLET (COMPL)(PCO)(4FT)(BOTH) DOLLARS and CENTS	EA	1.000	41
	465	6027	001	INLET (COMPL)(PCO)(6FT)(RIGHT) DOLLARS and CENTS	EA	2.000	42
	465	6029	001	INLET (COMPL)(PCU)(3FT)(NONE) DOLLARS and CENTS	EA	3.000	43
	465	6031	001	INLET (COMPL)(PCU)(3FT)(RIGHT) DOLLARS and CENTS	EA	2.000	44
	465	6044	001	INLET (COMPL)(PCU)(6FT)(BOTH) DOLLARS and CENTS	EA	1.000	45
	465	6070	001	INLET (COMPL)(PSL)(RC)(3FTX3FT) DOLLARS and CENTS	EA	14.000	46
	465	6071	001	INLET (COMPL)(PSL)(RC)(4FTX4FT) DOLLARS and CENTS	EA	9.000	47

ALT	ITEM-CODE			UNIT BID PRICE ONLY. WRITTEN IN WORDS	UNIT	APPROX QUANTITIES	DEPT USE ONLY
	ITEM NO	DESC CODE	S.P. NO.				
	465	6074	001	INLET (COMPL)(PSL)(RC)(5FTX5FT) DOLLARS and CENTS	EA	2.000	48
	465	6076	001	INLET (COMPL)(PSL)(RC)(6FTX6FT) DOLLARS and CENTS	EA	7.000	49
	465	6077	001	INLET (COMPL)(PSL)(RC)(8FTX8FT) DOLLARS and CENTS	EA	3.000	50
	465	6141	001	INLET (COMPL)(PSL)(FG)(6FTX6FT-4FTX- 4FT) DOLLARS and CENTS	EA	1.000	51
	465	6144	001	INLET (COMPL)(PSL)(FG)(8FTX8FT-4FTX- 4FT) DOLLARS and CENTS	EA	1.000	52
	465	6147	001	INLET(COMPL)(PSL)(SFG)(4FTX4FT-4FTX- 4FT) DOLLARS and CENTS	EA	4.000	53
	466	6150		WINGWALL (FW - 0) (HW=3 FT) DOLLARS and CENTS	EA	2.000	54
	467	6098		SET (TY I)(S=3 FT)(HW=2FT)(3:1)(C) DOLLARS and CENTS	EA	1.000	55
	467	6131		SET (TY I)(S= 4 FT)(HW= 2 FT)(3:1) (C) DOLLARS and CENTS	EA	1.000	56
	467	6168		SET (TY I)(S= 5 FT)(HW= 2 FT)(6:1) (P) DOLLARS and CENTS	EA	2.000	57
	467	6363		SET (TY II) (18 IN) (RCP) (6: 1) (P) DOLLARS and CENTS	EA	1.000	58

ALT	ITEM-CODE			UNIT BID PRICE ONLY. WRITTEN IN WORDS	UNIT	APPROX QUANTITIES	DEPT USE ONLY
	ITEM NO	DESC CODE	S.P. NO.				
	467	6395		SET (TY II) (24 IN) (RCP) (6: 1) (P) DOLLARS and CENTS	EA	2.000	59
	479	6003		ADJUSTING MANHOLES & INLETS DOLLARS and CENTS	EA	8.000	60
	496	6002		REMOV STR (INLET) DOLLARS and CENTS	EA	41.000	61
	496	6005		REMOV STR (WINGWALL) DOLLARS and CENTS	EA	2.000	62
	496	6007		REMOV STR (PIPE) DOLLARS and CENTS	LF	1,178.000	63
	496	6008		REMOV STR (BOX CULVERT) DOLLARS and CENTS	LF	150.000	64
	500	6001		MOBILIZATION DOLLARS and CENTS	LS	1.000	65
	502	6001	008	BARRICADES, SIGNS AND TRAFFIC HAN- DLING DOLLARS and CENTS	MO	28.000	66
	506	6020	005	CONSTRUCTION EXITS (INSTALL) (TY 1) DOLLARS and CENTS	SY	858.000	67
	506	6024	005	CONSTRUCTION EXITS (REMOVE) DOLLARS and CENTS	SY	858.000	68
	506	6035	005	SANDBAGS FOR EROSION CONTROL DOLLARS and CENTS	EA	496.000	69
	506	6038	005	TEMP SEDMT CONT FENCE (INSTALL) DOLLARS and CENTS	LF	850.000	70

ALT	ITEM-CODE			UNIT BID PRICE ONLY. WRITTEN IN WORDS	UNIT	APPROX QUANTITIES	DEPT USE ONLY
	ITEM NO	DESC CODE	S.P. NO.				
	506	6039	005	TEMP SEDMT CONT FENCE (REMOVE) DOLLARS and CENTS	LF	850.000	71
	506	6040	005	BIODEG EROSN CONT LOGS (INSTL) (8") DOLLARS and CENTS	LF	1,353.000	72
	506	6043	005	BIODEG EROSN CONT LOGS (REMOVE) DOLLARS and CENTS	LF	1,353.000	73
	508	6001		CONSTRUCTING DETOURS DOLLARS and CENTS	SY	145.000	74
	529	6001		CONC CURB (TY I) DOLLARS and CENTS	LF	82.000	75
	529	6005		CONC CURB (MONO) (TY II) DOLLARS and CENTS	LF	28,831.000	76
	529	6020		CONC CURB & GUTTER (ARMOR CURB) DOLLARS and CENTS	LF	294.000	77
	529	6026		CONC CURB (TY IV) DOLLARS and CENTS	LF	16.000	78
	530	6004		DRIVEWAYS (CONC) DOLLARS and CENTS	SY	11,022.000	79
	531	6001		CONC SIDEWALKS (4") DOLLARS and CENTS	SY	6,770.000	80
	531	6004		CURB RAMPS (TY 1) DOLLARS and CENTS	EA	12.000	81
	531	6005		CURB RAMPS (TY 2) DOLLARS and CENTS	EA	4.000	82

ALT	ITEM-CODE			UNIT BID PRICE ONLY. WRITTEN IN WORDS	UNIT	APPROX QUANTITIES	DEPT USE ONLY
	ITEM NO	DESC CODE	S.P. NO.				
	531	6006		CURB RAMPS (TY 3) DOLLARS and CENTS	EA	48.000	83
	533	6001		RUMBLE STRIPS (SHOULDER) DOLLARS and CENTS	LF	367.000	84
	540	6002	001	MTL W-BEAM GD FEN (STEEL POST) DOLLARS and CENTS	LF	250.000	85
	540	6006	001	MTL BEAM GD FEN TRANS (THRIE-BEAM) DOLLARS and CENTS	EA	2.000	86
	540	6016	001	DOWNSTREAM ANCHOR TERMINAL SEC- TION DOLLARS and CENTS	EA	1.000	87
	542	6001		REMOVE METAL BEAM GUARD FENCE DOLLARS and CENTS	LF	250.000	88
	542	6002		REMOVE TERMINAL ANCHOR SECTION DOLLARS and CENTS	EA	1.000	89
	542	6004		RM MTL BM GD FENCE TRANS (THRIE- BEAM) DOLLARS and CENTS	EA	2.000	90
	544	6001		GUARDRAIL END TREATMENT (INSTALL) DOLLARS and CENTS	EA	1.000	91
	544	6003		GUARDRAIL END TREATMENT (REMOVE) DOLLARS and CENTS	EA	1.000	92
	545	6001		CRASH CUSH ATTEN (INSTL) DOLLARS and CENTS	EA	2.000	93
	618	6023		CONDT (PVC) (SCH 40) (2") DOLLARS and CENTS	LF	490.000	94

ALT	ITEM-CODE			UNIT BID PRICE ONLY. WRITTEN IN WORDS	UNIT	APPROX QUANTITIES	DEPT USE ONLY
	ITEM NO	DESC CODE	S.P. NO.				
	618	6024		CONDT (PVC) (SCH 40) (2") (BORE) DOLLARS and CENTS	LF	1,165.000	95
	618	6029		CONDT (PVC) (SCH 40) (3") DOLLARS and CENTS	LF	345.000	96
	618	6030		CONDT (PVC) (SCH 40) (3") (BORE) DOLLARS and CENTS	LF	2,040.000	97
	618	6070		CONDT (RM) (2") DOLLARS and CENTS	LF	10.000	98
	620	6007		ELEC CONDR (NO.8) BARE DOLLARS and CENTS	LF	1,190.000	99
	620	6008		ELEC CONDR (NO.8) INSULATED DOLLARS and CENTS	LF	1,320.000	100
	620	6009		ELEC CONDR (NO.6) BARE DOLLARS and CENTS	LF	345.000	101
	620	6010		ELEC CONDR (NO.6) INSULATED DOLLARS and CENTS	LF	885.000	102
	624	6013		GROUND BOX TY 1 (122422) DOLLARS and CENTS	EA	12.000	103
	628	6148		ELC SRV TY D 120/240 060(NS)SS(E)TS(O) DOLLARS and CENTS	EA	2.000	104
	644	6001		IN SM RD SN SUP&AM TY10BWG(1)SA(P) DOLLARS and CENTS	EA	51.000	105
	644	6002		IN SM RD SN SUP&AM TY10BWG(1)SA(P- BM) DOLLARS and CENTS	EA	30.000	106

ALT	ITEM-CODE			UNIT BID PRICE ONLY. WRITTEN IN WORDS	UNIT	APPROX QUANTITIES	DEPT USE ONLY
	ITEM NO	DESC CODE	S.P. NO.				
	644	6004		IN SM RD SN SUP&AM TY10BWG(1)SA(T) DOLLARS and CENTS	EA	23.000	107
	644	6007		IN SM RD SN SUP&AM TY10BWG(1)SA(U) DOLLARS and CENTS	EA	8.000	108
	644	6017		IN SM RD SN SUP&AM TY10BWG(2)SA(P) DOLLARS and CENTS	EA	3.000	109
	644	6028		IN SM RD SN SUP&AM TYS80(1)SA(P-BM) DOLLARS and CENTS	EA	3.000	110
	644	6030		IN SM RD SN SUP&AM TYS80(1)SA(T) DOLLARS and CENTS	EA	4.000	111
	644	6033		IN SM RD SN SUP&AM TYS80(1)SA(U) DOLLARS and CENTS	EA	1.000	112
	644	6034		IN SM RD SN SUP&AM TYS80(1)SA(U-1EXT) DOLLARS and CENTS	EA	1.000	113
	644	6035		IN SM RD SN SUP&AM TYS80(1)SA(U-2EXT) DOLLARS and CENTS	EA	1.000	114
	644	6068		RELOCATE SM RD SN SUP&AM TY 10BWG DOLLARS and CENTS	EA	10.000	115
	644	6076		REMOVE SM RD SN SUP&AM DOLLARS and CENTS	EA	128.000	116
	658	6080		INSTL DEL ASSM (D-SW)SZ 1(WFLX)GND DOLLARS and CENTS	EA	24.000	117
	662	6005		WK ZN PAV MRK NON-REMOV (W)6"(BRK) DOLLARS and CENTS	LF	2,035.000	118

ALT	ITEM-CODE			UNIT BID PRICE ONLY. WRITTEN IN WORDS	UNIT	APPROX QUANTITIES	DEPT USE ONLY
	ITEM NO	DESC CODE	S.P. NO.				
	662	6008		WK ZN PAV MRK NON-REMOV (W)6"(SLD) DOLLARS and CENTS	LF	56,483.000	119
	662	6016		WK ZN PAV MRK NON-REMOV (W)24"(SLD) DOLLARS and CENTS	LF	544.000	120
	662	6035		WK ZN PAV MRK NON-REMOV (Y)6"(BRK) DOLLARS and CENTS	LF	10,921.000	121
	662	6037		WK ZN PAV MRK NON-REMOV (Y)6"(SLD) DOLLARS and CENTS	LF	86,424.000	122
	666	6036	007	REFL PAV MRK TY I (W)8"(SLD)(100MIL) DOLLARS and CENTS	LF	1,236.000	123
	666	6042	007	REFL PAV MRK TY I (W)12"(SLD)(100MIL) DOLLARS and CENTS	LF	5,058.000	124
	666	6048	007	REFL PAV MRK TY I (W)24"(SLD)(100MIL) DOLLARS and CENTS	LF	1,116.000	125
	666	6054	007	REFL PAV MRK TY I (W)(ARROW)(100MIL) DOLLARS and CENTS	EA	16.000	126
	666	6078	007	REFL PAV MRK TY I (W)(WORD)(100MIL) DOLLARS and CENTS	EA	6.000	127
	666	6102	007	REF PAV MRK TY I(W)36"(YLD TRI)(100MIL) DOLLARS and CENTS	EA	14.000	128
	666	6147	007	REFL PAV MRK TY I (Y)24"(SLD)(100MIL) DOLLARS and CENTS	LF	126.000	129
	666	6225	007	PAVEMENT SEALER 6" DOLLARS and CENTS	LF	53,098.000	130

ALT	ITEM-CODE			UNIT BID PRICE ONLY. WRITTEN IN WORDS	UNIT	APPROX QUANTITIES	DEPT USE ONLY
	ITEM NO	DESC CODE	S.P. NO.				
	666	6226	007	PAVEMENT SEALER 8" DOLLARS and CENTS	LF	1,236.000	131
	666	6228	007	PAVEMENT SEALER 12" DOLLARS and CENTS	LF	5,058.000	132
	666	6230	007	PAVEMENT SEALER 24" DOLLARS and CENTS	LF	1,242.000	133
	666	6231	007	PAVEMENT SEALER (ARROW) DOLLARS and CENTS	EA	16.000	134
	666	6232	007	PAVEMENT SEALER (WORD) DOLLARS and CENTS	EA	6.000	135
	666	6243	007	PAVEMENT SEALER (YLD TRI) DOLLARS and CENTS	EA	14.000	136
	666	6306	007	RE PM W/RET REQ TY I (W)6"(BRK)(100MIL) DOLLARS and CENTS	LF	1,140.000	137
	666	6309	007	RE PM W/RET REQ TY I (W)6"(SLD)(100MIL) DOLLARS and CENTS	LF	8,540.000	138
	666	6318	007	RE PM W/RET REQ TY I (Y)6"(BRK)(100MIL) DOLLARS and CENTS	LF	7,220.000	139
	666	6321	007	RE PM W/RET REQ TY I (Y)6"(SLD)(100MIL) DOLLARS and CENTS	LF	36,198.000	140
	672	6002		PLOWABLE REFL PAV MRKR TY I-C DOLLARS and CENTS	EA	1,075.000	141
	672	6003		PLOWABLE REFL PAV MRKR TY II-A-A DOLLARS and CENTS	EA	160.000	142

ALT	ITEM-CODE			UNIT BID PRICE ONLY. WRITTEN IN WORDS	UNIT	APPROX QUANTITIES	DEPT USE ONLY
	ITEM NO	DESC CODE	S.P. NO.				
	672	6004		PLOWABLE REFL PAV MRKR TY II-C-R DOLLARS and CENTS	EA	56.000	143
	677	6002		ELIM EXT PAV MRK & MRKS (6") DOLLARS and CENTS	LF	183,143.000	144
	678	6002		PAV SURF PREP FOR MRK (6") DOLLARS and CENTS	LF	62,118.000	145
	678	6004		PAV SURF PREP FOR MRK (8") DOLLARS and CENTS	LF	1,236.000	146
	678	6006		PAV SURF PREP FOR MRK (12") DOLLARS and CENTS	LF	5,058.000	147
	678	6008		PAV SURF PREP FOR MRK (24") DOLLARS and CENTS	LF	1,242.000	148
	678	6009		PAV SURF PREP FOR MRK (ARROW) DOLLARS and CENTS	EA	16.000	149
	678	6016		PAV SURF PREP FOR MRK (WORD) DOLLARS and CENTS	EA	6.000	150
	678	6023		PAV SURF PREP FOR MRK (36")(YLD TRI) DOLLARS and CENTS	EA	14.000	151
	680	6003	006	INSTALL HWY TRF SIG (SYSTEM) DOLLARS and CENTS	EA	2.000	152
	680	6004	006	REMOVING TRAFFIC SIGNALS DOLLARS and CENTS	EA	2.000	153
	681	6001		TEMP TRAF SIGNALS DOLLARS and CENTS	EA	2.000	154

ALT	ITEM-CODE			UNIT BID PRICE ONLY. WRITTEN IN WORDS	UNIT	APPROX QUANTITIES	DEPT USE ONLY
	ITEM NO	DESC CODE	S.P. NO.				
	682	6001		VEH SIG SEC (12")LED(GRN) DOLLARS and CENTS	EA	16.000	155
	682	6002		VEH SIG SEC (12")LED(GRN ARW) DOLLARS and CENTS	EA	8.000	156
	682	6003		VEH SIG SEC (12")LED(YEL) DOLLARS and CENTS	EA	16.000	157
	682	6004		VEH SIG SEC (12")LED(YEL ARW) DOLLARS and CENTS	EA	12.000	158
	682	6005		VEH SIG SEC (12")LED(RED) DOLLARS and CENTS	EA	16.000	159
	682	6006		VEH SIG SEC (12")LED(RED ARW) DOLLARS and CENTS	EA	6.000	160
	682	6018		PED SIG SEC (LED)(COUNTDOWN) DOLLARS and CENTS	EA	16.000	161
	682	6054		BACKPLATE W/REF BRDR(3 SEC)(VENT)ALUM DOLLARS and CENTS	EA	14.000	162
	682	6055		BACKPLATE W/REF BRDR(4 SEC)(VENT)ALUM DOLLARS and CENTS	EA	8.000	163
	684	6041		TRF SIG CBL (TY A)(14 AWG)(15 CONDR) DOLLARS and CENTS	LF	80.000	164
	684	6046		TRF SIG CBL (TY A)(14 AWG)(20 CONDR) DOLLARS and CENTS	LF	1,270.000	165
	684	6050		TRF SIG CBL (TY A)(16 AWG)(4 CONDR) DOLLARS and CENTS	LF	1,450.000	166

ALT	ITEM-CODE			UNIT BID PRICE ONLY. WRITTEN IN WORDS	UNIT	APPROX QUANTITIES	DEPT USE ONLY
	ITEM NO	DESC CODE	S.P. NO.				
	684	6051		TRF SIG CBL (TY A)(16 AWG)(5 CONDR) DOLLARS and CENTS	LF	385.000	167
	684	6052		TRF SIG CBL (TY A)(16 AWG)(7 CONDR) DOLLARS and CENTS	LF	1,000.000	168
	686	6027		INS TRF SIG PL AM(S)1 ARM(24')LUM DOLLARS and CENTS	EA	1.000	169
	686	6043		INS TRF SIG PL AM(S)1 ARM(40')LUM DOLLARS and CENTS	EA	1.000	170
	686	6045		INS TRF SIG PL AM(S)1 ARM(44') DOLLARS and CENTS	EA	1.000	171
	686	6047		INS TRF SIG PL AM(S)1 ARM(44')LUM DOLLARS and CENTS	EA	1.000	172
	686	6063		INS TRF SIG PL AM(S)1 ARM(60')LUM DOLLARS and CENTS	EA	1.000	173
	687	6001		PED POLE ASSEMBLY DOLLARS and CENTS	EA	6.000	174
	688	6001		PED DETECT PUSH BUTTON (APS) DOLLARS and CENTS	EA	16.000	175
	688	6003		PED DETECTOR CONTROLLER UNIT DOLLARS and CENTS	EA	2.000	176
	738	6114		CLEAN / SWEEP-OUTSIDE MAIN LANE- AREA(1) DOLLARS and CENTS	CYC	10.000	177
	3076	6001		D-GR HMA TY-B PG64-22 DOLLARS and CENTS	TON	24,403.000	178

ALT	ITEM-CODE			UNIT BID PRICE ONLY. WRITTEN IN WORDS	UNIT	APPROX QUANTITIES	DEPT USE ONLY
	ITEM NO	DESC CODE	S.P. NO.				
	6001	6002		PORTABLE CHANGEABLE MESSAGE SIGN DOLLARS and CENTS	EA	4.000	179
	6019	6007		PREFB PV MK W/WNTY TY B(W)6"(BRK)CNTST DOLLARS and CENTS	LF	9,020.000	180
	6058	6001		BBU SYSTEM (EXTERNAL BATT CABINET) DOLLARS and CENTS	EA	2.000	181
	6083	6002		VID IMAGE AND RADAR DET PROCESSOR SYS DOLLARS and CENTS	EA	2.000	182
	6083	6003		VIDEO IMAGING AND RADAR DETECTOR DOLLARS and CENTS	EA	8.000	183
	6083	6004		VIDEO IMAGING AND RADAR SET-UP SYS DOLLARS and CENTS	EA	2.000	184
	6083	6005		VID IMAGE AND RADAR COM CABLE (COAX) DOLLARS and CENTS	LF	1,665.000	185
	6185	6002	002	TMA (STATIONARY) DOLLARS and CENTS	DAY	15.000	186
	6185	6003	002	TMA (MOBILE OPERATION) DOLLARS and CENTS	HR	150.000	187

CERTIFICATION OF INTEREST IN OTHER BID PROPOSALS FOR THIS WORK

By signing this proposal, the bidding firm and the signer certify that the following information, as indicated by checking "Yes" or "No" below, is true, accurate, and complete.

- A. Quotation(s) have been issued in this firm's name to other firm(s) interested in this work for consideration for performing a portion of this work.

_____ YES

_____ NO

- B. If this proposal is the low bid, the bidder agrees to provide the following information prior to award of the contract.

1. Identify firms which bid as a prime contractor and from which the bidder received quotations for work on this project.
2. Identify all the firms which bid as a prime contractor to which the bidder gave quotations for work on this project.

ENGINEER SEAL

Control 0168-07-043, ETC.

Project C 168-7-43, ETC.

Highway US 60

County DEAF SMITH

The enclosed Texas Department of Transportation Specifications, Special Specifications, Special Provisions, General Notes and Specification Data in this document have been selected by me, or under my responsible supervision as being applicable to this project. Alteration of a sealed document without proper notification to the responsible engineer is an offense under the Texas Engineering Practice Act.

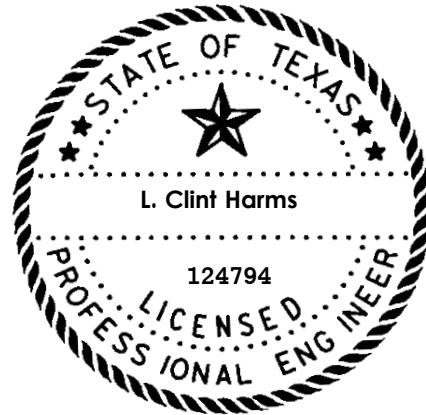

The seal appearing on this document was authorized by
L. Clint Harms, P.E.
JANUARY 03, 2024

GENERAL NOTES

CSJ: 0168-07-043, ETC				
BASIS OF ESTIMATE FOR CONSTRUCTION				
Item	Description	Unit	Rate	
164	SEEDING		SEE PLAN SHEETS	
166	FERTILIZER		SEE PLAN SHEETS	
168	VEGETATIVE WATERING	MG	81.0 MG/AC	
275	CEMENT TREAT (8")	SY	3.5% Cement at 26.25 LBS/SY	
3076 ⁽¹⁾	D-GR HMA	TON	3"	330 LB/SY/2000
NOTE:				
(1)	D-GR HMA TY-B PG64-22 Weight Based On 110Lbs/SY/In			

General

Contractor questions on this project are to be addressed to the following individual(s):

TO: Amarillo Area Engineer Joe.Chappell@txdot.gov
 CC: Assistant Area Engineer CC.Sysombath@txdot.gov
 Director of Construction Kenneth.Petr@txdot.gov
 Construction Manager Darrell.Caldwell@txdot.gov

Contractor questions will be accepted through email, phone, or in person by the above individuals.

For Q&A's on Proposals navigate to:

<https://tableau.txdot.gov/views/ProjectInformationDashboard/NoticetoContractors>

Use the dashboard to navigate to the project you are interested in by scrolling or filtering the dashboard using the controls on the left. Hover over the blue hyperlink of the project you want to view the Q&A for and click on the link in the window that pops up.

All relevant project documentation including CTD and cross sections will be posted to TxDOT District's FTP website.

<https://ftp.dot.state.tx.us/pub/txdot-info/Pre-Letting%20Responses/>

Verify all survey control prior to beginning construction. Notify Engineer of any discrepancies in control prior to beginning construction.

Highway: US 60

Control: 0168-07-043, ETC

There are approximately 2 "reference markers" within the project limits. If a marker needs to be moved for any reason during construction operations, the Contractor is to remove it, install it in a temporary location and then reinstall it in its correct permanent location. Both the temporary and permanent locations are to be on a line that is perpendicular to the original "station" along the roadway. The temporary location is to be at or near the right-of-way. The permanent location is to be directed by the Engineer.

See Railroad Scope of Work sheet for insurance and/or other requirements.

The Contractor is advised that a construction speed zone will be applicable for this project and is to be limited to the actual work areas under construction. The approved construction speed limit will be made available upon request to the Engineer.

Remove all excess material from bridge substructure resulting from all construction including planing, seal coat and ACP overlays. This work will not be paid for directly, but will be considered subsidiary to various bid items in the contract.

If Contractor damages any sprinkler heads, risers or water lines that are not to be relocated, he or she is required to replace or repair all damage at his or her own expense and to the Engineer's satisfaction.

If portions of the right-of-way is used to store materials, equipment, and other uses with the approval of the Engineer, materials, equipment, etc., must either be located outside the 30 feet traffic safety clearance zone or be adequately protected.

Contractor facilities, such as asphalt plants, concrete plants, rock crushers, etc. are not allowed to be located within Department right of way.

The slopes indicated on the typical sections may be varied when fixed features required slopes are re-established as directed by the Engineer.

Dust caused by construction operations is to be controlled by applying water in conformance with the requirements of Item 204, "Sprinkling". Sprinkling for dust control will not be paid for directly, but will be considered as subsidiary work to the various bid items.

Any work necessary to provide temporary ingress and egress during construction (such as building gravel ramps, etc.) Will not be paid for directly, but will be considered as subsidiary work to the various bid items.

Verify all existing grades, elevations, and cross slopes that will connect to any proposed grades and elevations. If adjustments are warranted, the Contractor is to submit proposed changes to the Engineer for verification.

Item 7 Legal Relations and Responsibilities

No significant traffic generator events identified.

Item 8 Prosecution and Progress

Create, maintain, and submit for acceptance, a Critical Path Method (CPM) project schedule and a Project Schedule Summary Report (PSSR) using computer software that is fully compatible with the latest version of Primavera Systems, Inc. or Primavera P6.

The 90 days delay special provision is intended to provide lead time to acquire required precast drainage elements and aggregate for HMA & CRCP.

Prosecute the work following the sequence shown in the traffic control plan narrative and corresponding traffic control plan.

Working days will be computed and charged in accordance with Article 8.3.1.1 Five-Day Workweek, except as identified in milestone general notes.

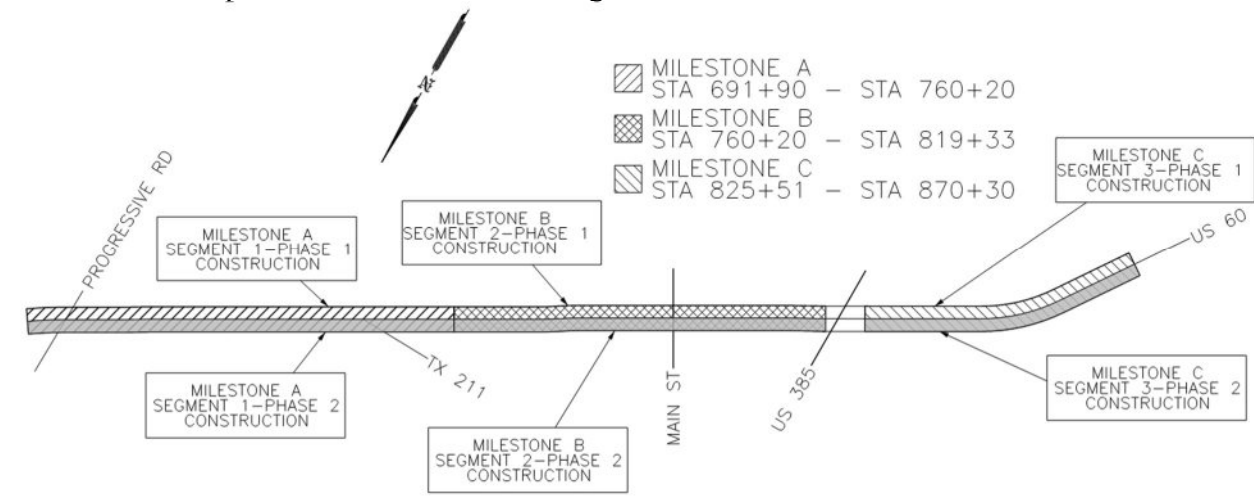

Milestone A - STA 691+90 – STA 760+20

The purpose of Milestone A is to reconstruct US 60 travel lanes as quickly as possible.

The time allowed for the roadway construction is 269 working days in accordance with Article 8.3.1 Five-Day Workweek.

Milestone A begins when either Eastbound or Westbound is reduced to a single through lane for more than a 12-hour duration.

Milestone A time charges will end when all lanes shown on the proposed typical sections are open to traffic.

After the completion of Milestone A, a periodic single lane closure is acceptable. Any lane closure will be no greater than a 12-hour duration will count as a milestone working day.

If Milestone A is complete, as defined above, earlier than the stated number of working days, a bonus of \$5,000 per day for a maximum of 50 days will be awarded. If Milestone A is not completed, as defined above, within the stated number of days, contract administration and road

user liquidated damages of \$2,000 per day will be assessed for each day in excess of the stated number of allowable working days for the project until the milestone requirements are met. The working period charged during Milestone A will also be included in the computation of the total time charges for the total completion of the project.

Milestone B - STA 760+20 – STA 819+33

The purpose of Milestone B is to reconstruct US 60 travel lanes as quickly as possible.

The time allowed for the roadway construction is 287 working days in accordance with Article 8.3.1 Five-Day Workweek.

Milestone B begins when either Eastbound or Westbound is reduced to a single through lane for more than a 12-hour duration.

Milestone B time charges will end when all lanes shown on the proposed typical sections are open to traffic.

After the completion of Milestone B, a periodic single lane closure is acceptable. Any lane closure will be no greater than a 12-hour duration will count as a milestone working day.

If Milestone B is complete, as defined above, earlier than the stated number of working days, a bonus of \$5,000 per day for a maximum of 60 days will be awarded. If Milestone B is not completed, as defined above, within the stated number of days, contract administration and road user liquidated damages of \$2,000 per day will be assessed for each day in excess of the stated number of allowable working days for the project until the milestone requirements are met. The working period charged during Milestone B will also be included in the computation of the total time charges for the total completion of the project.

Milestone C - STA 825+51 – STA 870+30

The purpose of Milestone C is to reconstruct US 60 travel lanes as quickly as possible.

The time allowed for the roadway construction is 170 working days in accordance with Article 8.3.1 Five-Day Workweek.

Milestone C begins when either Eastbound or Westbound is reduced to a single through lane for more than a 12-hour duration.

Milestone C time charges will end when all lanes shown on the proposed typical sections are open to traffic.

After the completion of Milestone C, a periodic single lane closure is acceptable. Any lane closure will be no greater than a 12-hour duration will count as a milestone working day.

Highway: US 60

Control: 0168-07-043, ETC

If Milestone C is complete, as defined above, earlier than the stated number of working days, a bonus of \$5,000 per day for a maximum of 30 days will be awarded. If Milestone C is not completed, as defined above, within the stated number of days, contract administration and road user liquidated damages of \$2,000 per day will be assessed for each day in excess of the stated number of allowable working days for the project until the milestone requirements are met. The working period charged during Milestone C will also be included in the computation of the total time charges for the total completion of the project.

Item 100 Preparing Right Of Way

All tree removal activities are to take place outside nesting season. See EPIC for nesting season.

Remove trees of various diameters as shown on the plans, or as directed. Remove tree stumps to at least 12 in. below the surrounding terrain. Before backfilling holes treat the remainder of the stump with the following herbicide: Manufacture - Dow AgroScience; Product - Remedy or other as approved by the Engineer. Follow manufacture recommendations for herbicide. Backfill holes with acceptable material and compact flush with surrounding areas.

Identify each individual tree proposed to be removed. Obtain approval from the Engineer in the field for each individual tree proposed to be removed prior to any tree being removed.

Item 110 Excavation

Before grading begins, the vegetative cover within the areas to be graded are to be bladed into a windrow outside the limits of the slopes. After all grading is complete; the vegetative cover is to be spread over the adjacent disturbed areas. This work is not to be paid for directly, but will be considered subsidiary work to the various bid items.

Prior to excavation and placement of embankment, the top-soil (6-inch depth) within the areas to be disturbed will be bladed into a windrow, or stockpiled, outside the limits of the fill slope. After all grading is completed; the top soil (6-inch depth) will be spread over the disturbed areas that will not receive concrete riprap. This work is not paid for directly, but will be considered as subsidiary work to the various bid items.

Item 132 Embankment

The plasticity index for TY B will not exceed 25.

Materials excavated from the project will be allowed to be used on the project as directed by the Engineer.

Item 162 Sodding for Erosion Control

Furnish and place sod matching existing type.

Item 168 Vegetative Watering

Vegetative watering is estimated at 0.25" per week placed over the seeded area to keep the soil in a moist state that promotes germination and growth. Begin application of the watering following a rain that presoaks the soil and continue for approximately 3 months, or as directed by the

Highway: US 60

Control: 0168-07-043, ETC

Engineer. If rains occur that keep the soil moist, delay the watering. Provide the appropriate type and amount of equipment to necessary watering.

Item 275 Cement Treatment (Road-Mixed)

The intent of this item is to pulverize existing ACP and blend with the existing flexible base. Consider the existing ACP and flexible base as existing base material, and payment made under this item includes pulverizing the existing materials.

All required moisture added for the mixing and compaction operation is to be injected through the mixing process. Sprinkle the base material to prevent excessive loss of moisture as directed by the Engineer.

Backfill any vertical edge nightly with a material approved by the Engineer and at a minimum slope of 3:1.

Spread the cement with a vane feeder system approved by the Engineer that is capable of spreading the cement uniformly to within 5 percent of the specified rate.

Item 320 Equipment for Asphalt Concrete Pavement

A self-propelled, wheel mounted material transfer vehicle (MTV) capable of receiving hot mix from the haul trucks separate from the paver is required on all courses and all types of hot mix for this project. The MTV is to have a minimum storage capacity of approximately 25 tons, and equipped with a pivoting discharge conveyor and a means of completely remixing the hot mix prior to placement. The paver hopper is to be equipped with a separate surge storage insert with a minimum capacity of approximately 20 tons.

If used, the IR bar read out screen must be visible at all times to the Engineer.

When performing any scheduled work during night time hours (sunset to sunrise) all work areas will be fully illuminated using devices designed to not incumber or distract oncoming traffic. All illumination equipment must be approved by the Engineer in writing 48 hours before any scheduled night time work can begin. All associated equipment and labor is considered subsidiary to the item of work and will not be paid for directly.

Item 360 Concrete Pavement

Multiple piece tie bars will be required.

Provide longitudinal tining.

A pre-paving meeting will be required.

Air-entrain class P concrete at 4.5% air.

Item 416 Drilled Shaft Foundations

A stabilization method is to be used to prevent caving of the material and is to be submitted as part of the Contractor's Safety Plan.

Do not use the Slurry Displacement Method.

Calculate signal head clearance and report to the Engineer. Obtain Engineer's approval of location before installing foundation.

Item 421 Hydraulic Cement Concrete

The sand equivalent value of fine aggregate is not to be less than 85 when subjected to test method tex-203-F.

All cast-in-place concrete except for drilled shafts are to be air-entrained. Pre-cast and drilled shaft concrete may be air-entrained at the Contractor's option.

Item 432 Riprap

24" tie bars (#3 bars at 18" c-c) are to be used across all construction joints. Tie bars should be 12" into each side of the construction joint. When tying new riprap into existing riprap drill and epoxy grout 8" minimum into existing concrete. This is to be considered subsidiary to the payment for riprap.

Use of #3 rebar for reinforcing is required.

Item 462 Concrete Box Culverts and Storm Drains

Joint material for reinforced concrete pipe is to be either cold applied preformed plastic gaskets or cold applied plastic asphalt sewer joint compound.

Backfill pipe up to the springline with granular material. The ponding method of backfilling will be allowed for the granular material only.

Item 464 Reinforced Concrete Pipe

Joint material for all pipes will be cold applied plastic asphalt sewer joint compound.

Bedding for pipe culverts is to be 6 inches of sand. The excavation required to place the sand will not be paid for directly but will be considered subsidiary to this item.

Backfill pipe up to the springline with granular material. The ponding method of backfilling will be allowed for the granular material only.

Item 465 Manholes and Inlets

Place concrete inverts in all inlets & manholes/Jct Boxes. This work will not be paid for directly but will be considered subsidiary to this item.

Item 467 Safety End Treatment

Pre-cast Safety End Treatments are allowed; however, a cast-in-place concrete apron will be required as shown on the plans & will be subsidiary to the Safety End Treatment.

Item 502 Barricades, Signs, and Traffic Handling

The Contractor Force Account "Safety Contingency" that has been established for this project is intended to be utilized for work zone enhancements, to improve the effectiveness of the Traffic Control Plan, that could not be foreseen in the project planning and design stage. These enhancements will be mutually agreed upon by the Engineer and the Contractor's Responsible Person based on weekly or more frequent traffic management reviews on the project. The Engineer may choose to use existing bid items if it does not slow the implementation of enhancement.

Temporary rumble strips will be required as shown on WZ(RS)-22 regardless of loose gravel, and/or soft or bleeding asphalt. Adjust the traffic control setup such that rumble strips are not placed in areas of heavily rutted pavements, unpaved surfaces, or horizontal curves. Temporary rumble strips will not be allowed on interstate highway.

The Contractor is to have the option of using either plastic drums, vertical panels, grabber cones or a combination where drums are shown as channelizing devices, as approved by the Engineer. Plastic drums are to be used in all transition areas in accordance with BC(8)-21 and WZ(TD)-17.

Notify the Engineer 24 hours prior to any lane closure.

Contractor is to use the Texas Manual on Uniform Traffic Control Devices to ensure that no traffic will be stopped within the Rail Road Right of Way. Contractor is to insure all TCP and construction remain out of the Rail Road Right of Way.

Any work being done above travel lanes will require the lanes to be closed for traffic safety.

Item 504 Field Office and Laboratory

The following building(s) will be required for this project:

One Type (B) field office and laboratory

One Type (D) structure, asphalt mix control laboratory

Each building is to be provided before work is begun on the pertinent construction items for which it is needed.

Any laboratory furnished is to be a minimum of 10 ft in width.

All-weather parking area and chain link security fence will not be required.

The Type D structures are to be equipped with the following in addition to requirements specified under item 504:

Highway: US 60

Control: 0168-07-043, ETC

- a. Safety equipment
 - (1) One eye wash station
 - (2) One fire extinguisher
 - (3) One first aid kit

Furnish a Type D structure for the asphalt mix control laboratory for the Engineer's exclusive use. In addition to requirements of item 504, this structure is to have a minimum height of 8 feet and provide a minimum 400 square feet gross floor area for permanently located plants or 200 square feet for temporary located plants serving one project. The floor area will be partitioned into a minimum of two interconnected rooms, each room furnished with an exterior door and a minimum of two windows. The floor is to have sufficient strength to support the testing equipment and have an impervious covering.

The Type D structures are to be adequately air conditioned and be furnished with a minimum of one desk and three chairs. The structure is to be provided with a 240-volt electrical service entrance. The service is to consist of a minimum of 4 - 120 volt circuits with 20 amp breakers and no more than two grounded convenience outlets per circuit and provisions for a minimum of two 220-volt ovens with vents to the outside. The structure is to have a minimum of 2 convenience outlets per wall, and a utility sink with an adequate clean potable water supply for testing. The state building is to be equipped with at minimum a hot water dispenser or hot water heater capable of generating 1 gallon of water per use at 140° F with adequate water pressure. Space heaters for heating the structure are unacceptable. Portable structures are to be support blocked for stability and are to be tied down.

For this project, asphalt content will be determined utilizing the ignition method so the structure is to provide for the following in lieu of the item 504 requirements for asphalt content by extraction. The room to contain the ignition oven is to be adequately power ventilated and contain a NEMA 6-50r (208/240 v, 50 a) outlet within 2.5 feet of the ignition oven location and an independent exhaust outlet to the outside no further than 8 feet from the oven. The surface for the ignition oven location is to be level, sturdy, and fireproof with at least 6-inch clearance between the furnace and other vertical surfaces.

If needed, each building is to be moved to a new location as directed by the Engineer. Any building that is no longer required on the job after completion of the pertinent construction items may be released to the Contractor upon consent of the Engineer.

Item 506 Temporary Erosion, Sedimentation, and Environmental Controls

Erosion control devices are to be installed as needed in coordination with the work progress, or as directed by the Engineer.

Use wooden stakes to secure erosion control logs. Do not use rebar stakes.

Item 529 Concrete Curb, Gutter, and Combined Curb and Gutter

Expansion joints are to be at least one-half inch thick and spaced at maximum intervals of 40 feet. Planes of weakness are to be spaced at approximately ten feet intervals. Joint material will comply with ASTM-D 1751.

Item 531 Sidewalks

Sidewalks will be constructed using: 1" compacted sand cushion, reinforcing steel to be 6"x6" W1.4 x W1.4 welded wire mesh (1 1/2" above sand) or No.3 bar 18" O.C. with grooved joint every 10' and 1/2" fiber board expansion joint every 40'. Between back of curb and sidewalk 1/2" fiber board expansion joint will be used.

Item 533 Milled Rumble Strips

Use the applicable option in the table below for installation of the continuous milled depressions, as shown on the Edge Line Rumble Strips standards **RS(1)-23** and **RS(2)-23**.

Edge Line Rumble Strips, on the outer shoulder of divided highway, will require a gap spacing of 20' following 60' of rumble strip to allow for bicycle consideration as shown on RS(6)-23.

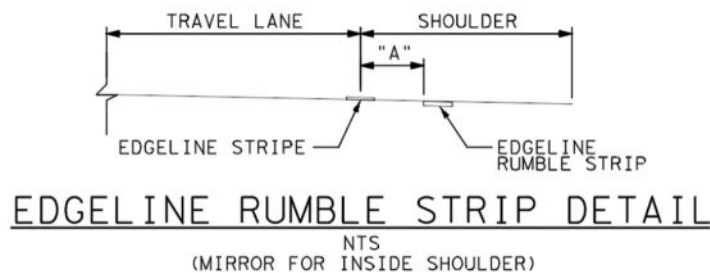

SHOULDER WIDTH (SW)	RUMBLE STRIP WIDTH (RS)	PLACEMENT "A"	OPTION (SEE RS(1)-23 or RS(2)-23)
SW ≤ 2'	8" RS	SEE RS(1)-13	Option 1
2' < SW ≤ 8'	8" RS	4" OFF EDGE LINE	Option 3
SW ≥ 8'	16" RS	24" OFF EDGE LINE	Option 4
All Inside Shoulders on 4-lane Divided Highways	16" RS	4" OFF EDGE LINE	Option 3

Use milled option 1 for installation of the Centerline Rumble Strips, as shown on the Standard Sheet **RS(3)-23** and **RS(4)-23**.

County: Deaf Smith

Sheet:

Highway: US 60

Control: 0168-07-043, ETC

Item 540 Metal Beam Guard Fence

Drive steel posts for metal beam guard fence a minimum of 1/3 of the post length to final specified depth.

Item 542 Removing Metal Beam Guard Fence

All MBGF, GET & TAS materials will remain property of the Contractor.

Item 544 Guardrail End Treatments

Use Single Guardrail End Treatment (Ty III)(Steel Post).

Item 585 Ride Quality for Pavement Surfaces

Use Surface Test Type B pay adjustment schedule 1 to evaluate ride quality of the travel lanes in accordance with Item 585, "Ride Quality for Pavement Surfaces."

Item 618 Conduit

The locations of conduit as shown are for diagrammatic purposed only and may be varied to meet local conditions, subject to approval. Backfill all open trenches before the end of the workday and do not leave any trench open overnight.

Item 620 Electrical Conductors

Provide breakaway electrical connectors for breakaway poles. Use Bussman HEBW, Littlefuse LEB, Ferraz-Shawmut FEB, or equal on ungrounded conductors. For grounded conductors, use Bussman HET, Littlefuse LET, Ferraz-Shawmut FEBN, or equal. These breakaway connectors have a white colored marking and a permanently installed solid neutral. See the latest RID (2) standard for additional details.

Clearly and permanently mark each illumination conductor installed in a signal pole as "ILLUMINATION" where it can be clearly seen from the hand hole. Use plastic zip ties with labeling plate to mark conductor.

Item 624 Ground Boxes

Do not place ground boxes in driveways or wheelchair ramps. Alternate ground box locations will be as directed.

Item 628 Electrical Services

Notify the utility company as soon as possible in order to minimize delay and coordinate the work necessary for the utility company to provide power.

The Contractor is responsible for submitting application(s) to applicable utility company which will be set up in the Contractor’s name with 911 address(es) for service location(s). Costs and charges from the utility company will be paid by the Department in accordance with the standard specification.

Once the project is complete and accepted by the Department, the Department will transfer utility services into the Department’s name using the corresponding 911 addresses and meter numbers.

Item 644 Small Roadside Sign Supports and Assemblies

ALUMINUM SIGN BLANKS THICKNESS	Square Feet	Minimum Thickness
	Less than 7.5	0.100
	7.5 or Greater	0.125

All slip base signs will have a triangular slip base with a 2-bolt clamp to prevent rotation of signpost. Set screw type slip base will not be allowed.

A 7" x 1/2" diameter galvanized rod or #4 rebar is to be installed in the sign stub as shown on SMD(SLIP-1)-08 to prevent rotation of the sign stub in the concrete footing.

The exact locations of the large and small roadside signs are to be as designated by the Engineer.

The existing riprap aprons are to be removed and disposed of as approved by the Engineer. This work is not to be paid for directly, but will be considered subsidiary to the removal of foundations under this item.

Probe before drilling for foundations to determine the location of all utilities and structures. This work will not be paid for directly, but will be considered subsidiary to bid items involved.

Details for standard signs not shown on the signing standards of the signing detail plan sheets are to be in conformance with the department's "Standard Highway Sign Designs for Texas" Manual, Latest Edition.

Install a wrap of retroreflective sheeting conforming to DMS-8300 on all posts for small road sign assemblies. Sign post wraps will not be paid for directly, but are considered subsidiary to Item 644.

Install red sheeting on the posts containing the following signs:
Stop, Yield, Wrong Way & Do Not Enter

Install yellow sheeting on all other small sign posts.

Highway: US 60

Control: 0168-07-043, ETC

Install all retroreflective wraps at a height of 4 ft. from bottom of the wrap to the edge of the travel lane surface. All retroreflective wraps will cover the full circumference of the sign post for a vertical width of 12 inches.

Item 658 Delineator and Object Marker Assemblies

For all ground mount applications provide hollow or tubular posts embedded in concrete using plastic wedged anchor system.

For all concrete barrier, bridge rail, and guard fence post mounted applications provide hollow or tubular posts with approved anchorage.

Item 666 Reflectorized Pavement Markings

Retroreflectivity Requirements:

All Type I markings must meet the minimum retroreflectivity values for edgeline markings, centerline or no passing barrier-line, and lane lines when measured any time after 3 days, but not later than 10 days after application:

- ◆ White markings: 250 millicandelas per square meter per lux (mcd/m²/lx)
- ◆ Yellow markings: 175 mcd/m²/lx

Retroreflectivity Measurements: Mobile or portable retroreflectometers may be used at the Contractor's discretion.

All Type I markings must meet the minimum retroreflectivity values for edgeline markings, centerline or no passing barrier-line, and lane lines when measured any time after 3 days, but not later than 10 days after application.

Item 677 Eliminating Existing Pavement Markings and Markers

Do not remove any existing pavement markings in any area in which the contractor is not able to place work zone pavement markings at the proper location within the same day.

Item 680 Highway Traffic Signals

Furnish and install all required materials, incidentals and equipment necessary for a fully operational traffic signal. The proposed equipment is to be compatible with the existing traffic control systems in use by the local traffic signal operating and maintaining agency. Refer to TxDOT's Website for prequalified products list regarding cameras, vehicle LED traffic signal lamp unit, symbolic pedestrian signal head, symbolic pedestrian signal lamp, conduit, conductors, ground boxes and electric service. Check website periodically for current updates.

Furnish and install illumination fixtures mounted on Traffic Signal Pole luminaire arms. Use 250W equivalent LED luminaires.

Highway: US 60

Control: 0168-07-043, ETC

Regulatory and street name signs shown to be mounted on the mast arms will be furnished and installed by the Contractor. All brackets and miscellaneous material will be furnished by the Contractor.

The Contractor will be responsible for adjustments in project construction which may be needed because of conflicts with utilities. In addition to calling Texas811 at all locations shown on the plans, contact the Amarillo District Headquarters signal shop at least 2 weeks in advance of work at the proposed locations. A representative from the signal shop will verify that no existing TxDOT electrical systems will interfere with the proposed work.

If overhead or underground power lines need to be de-energized, contact the electrical service provider to perform this work. Cost associated with de-energizing the power lines or other protective measures required will be at no expense to the Department. If working near power lines, comply with the appropriate sections of Texas state law and federal regulations relating to the type of work involved.

Once the integrity and /or function of an existing traffic signal(s) are altered by the Contractor, maintain and operate the existing traffic signal(s) until the traffic signal work is accepted by the department. Pursue the work at that location without delay or interruption to restore operation to its original or final operational design.

When work requires the removal of power from the controller and cabinet assembly, erect temporary stop signs. Remove the stop signs after the traffic signals are in operation.

The Contractor will not put signals in operation. Authorized TxDOT personnel must be onsite for controller start up.

Removing Traffic Signals - TxDOT will determine if signal components are designated for reuse. Other traffic signal materials salvaged from this project will become the property of the Contractor. Remove these salvaged materials from the project and dispose of in accordance with all applicable State and Local laws and regulations.

Item 681 Temporary Traffic Signals

Portable temporary traffic signals will be measured on a unit basis, for each complete system including any reconfigurations. A complete system consists of two portable temporary traffic signals and the interconnect between them. A complete system also includes operation, maintenance, moving, and removing the signals. No payment will be made for removing and replacing damaged portable temporary traffic signals.

Perform all required maintenance during operation of the portable temporary traffic signal. Record the following information:

- ◆ Dates and times when service and maintenance is performed,
- ◆ Description of service and a reason why service was performed,
- ◆ Any operational or equipment failures of the unit,
- ◆ Repairs made to the unit,

Highway: US 60

Control: 0168-07-043, ETC

- ◆ Operational history of the unit,
- ◆ All timing parameters input into the controller.

Store the log of recorded information with the corresponding temporary traffic signal at all times.

If the portable temporary traffic signal fails during operation for any reason, program signals to flash red and immediately provide flaggers to control traffic until the portable temporary traffic signal is operational.

Item 682 Vehicle and Pedestrian Signal Heads

Cover new signal heads so that the faces cannot be seen from the time of installation until the signal are placed in operation. Trash bags, paper, etc. will not be acceptable for use in covering signal heads. Signal head covers will be made of burlap or other out-door fabric which will be weather resistant as approved by the Engineer.

Signal heads are to be installed level and plumb and aimed as directed.

Item 684 Traffic Signal Cables

For each traffic signal installation where signal cable is required, provide a minimum length of 5 feet for each conductor terminating in the controller.

Label all traffic signal cables, vehicle detector cables, and pedestrian signal cables terminating in the controller with marker ties and permanent markers.

Item 686 Traffic Signal Pole Assemblies (Steel)

Provide all signal poles for a project from the same manufacturer. Provide round shafts for poles and mast arms unless otherwise shown on the plans. Install mast arm damping plates at the end of SMA and DMA standard poles in accordance with the details shown in the MA-DPD standard sheet. Dampers for LMA poles may be required as directed by the Engineer.

Item 738 Cleaning and Sweeping Highways

Cleaning and sweeping existing pavements will be done with a frequency of 8 cycles per year in the following months: December thru April, June, August & October or as directed by the Engineer.

Location of sweeping will be all open travel lanes.

Item 3076 Dense Graded Hot Mix Asphalt

Use aggregate that meets the SAC requirement of class A.

Use of RAS is not allowed.

Only fractionated RAP is allowed.

Provide a laboratory mixture design with the minimum target asphalt binder content shown below:

D-GR HMA TY B 4.6%

The District Lab will perform a maximum of 2(two) design verification tests. If additional verification tests are needed, the Contractor will be billed \$3,500.00 per each additional verification test required to obtain an approved asphaltic concrete pavement mix design.

If lime is not used as an antistrip agent, then the production and placement testing frequency for the Boil test (TEX-530-C) shown in the table below.

Description	Test Method	Minimum Contractor Testing Frequency	Minimum Engineer Testing Frequency
Boil test	Tex-530-C	1 per lot	1 per 12 sublots

If used, the IR bar read out screen must be visible at all times to the Engineer.

Item 6001 Portable Changeable Message Sign

Supply 2 Portable Changeable Message Signs (Type II – Lamp Matrix) for this project. No payment will be made for removing and replacing damaged PCMS.

If the Contractor chooses to have more than one lane closure set-up at a time, provide additional PCMS in accordance with TCP at no additional charge to the department.

Item 6083 Video Imaging and Radar Vehicle Detection System

Mount detector as shown in plans or as directed by the engineer. Adjust heights and locations of sensors to achieve the best possible detection. Provide a factory certified representative for testing and set up of the equipment at the time of signal flash and turn on. Furnish and install communication system (Edge Connect or equal as approved by the Engineer) to provide video communication back to TxDOT.

Item 6185 Truck Mounted Attenuator (TMA) and Trailer Attenuator (TA)

In addition to the shadow vehicles with truck mounted attenuator (TMA) that are specified as being required on the traffic control plan for this project, provide 0 additional shadow vehicle(s) with TMA for TCP(2-1)-18, (2-3)-18, (2-4)-18, (2-5)-18, (2-6)-18, (3-1)-13, (3-2)-13, (3-3)-14, as detailed on the General Notes of this standard sheets.

Therefore, 2 total shadow vehicles with TMA will be required for this type of work. The Contractor will be responsible for determining if one or more of these operations will be ongoing at the same time to determine the total number of TMAs needed for the project.

CONTROL : 0168-07-043, ETC
PROJECT : C 168-7-43, ETC
HIGHWAY : US 60
COUNTY : DEAF SMITH

TEXAS DEPARTMENT OF TRANSPORTATION

GOVERNING SPECIFICATIONS AND SPECIAL PROVISIONS

ALL SPECIFICATIONS AND SPECIAL PROVISIONS APPLICABLE TO THIS PROJECT ARE IDENTIFIED AS FOLLOWS:

STANDARD SPECIFICATIONS: ADOPTED BY THE TEXAS DEPARTMENT OF
----- TRANSPORTATION NOVEMBER 1, 2014.
STANDARD SPECIFICATIONS ARE INCORPORATED
INTO THE CONTRACT BY REFERENCE.

ITEMS 1 TO 9 INCL., GENERAL REQUIREMENTS AND COVENANTS
ITEM 100 PREPARING RIGHT OF WAY (103)
ITEM 104 REMOVING CONCRETE
ITEM 110 EXCAVATION
ITEM 132 EMBANKMENT
ITEM 162 SODDING FOR EROSION CONTROL
ITEM 164 SEEDING FOR EROSION CONTROL
ITEM 168 VEGETATIVE WATERING
ITEM 275 CEMENT TREATMENT (ROAD-MIXED)
ITEM 305 SALVAGING, HAULING, AND STOCKPILING RECLAIMABLE ASPHALT
PAVEMENT
ITEM 341 DENSE-GRADED HOT-MIX ASPHALT
ITEM 351 FLEXIBLE PAVEMENT STRUCTURE REPAIR
ITEM 360 CONCRETE PAVEMENT
ITEM 401 FLOWABLE BACKFILL
ITEM 416 DRILLED SHAFT FOUNDATIONS
ITEM 432 RIPRAP
ITEM 450 RAILING
ITEM 462 CONCRETE BOX CULVERTS AND DRAINS
ITEM 464 REINFORCED CONCRETE PIPE
ITEM 465 JUNCTION BOXES, MANHOLES, AND INLETS
ITEM 466 HEADWALLS AND WINGWALLS
ITEM 467 SAFETY END TREATMENT
ITEM 479 ADJUSTING MANHOLES AND INLETS
ITEM 496 REMOVING STRUCTURES
ITEM 500 MOBILIZATION
ITEM 502 BARRICADES, SIGNS, AND TRAFFIC HANDLING
ITEM 504 FIELD OFFICE AND LABORATORY
ITEM 506 TEMPORARY EROSION, SEDIMENTATION, AND ENVIRONMENTAL
CONTROLS

ITEM 508 CONSTRUCTING DETOURS
 ITEM 529 CONCRETE CURB, GUTTER, AND COMBINED CURB AND GUTTER
 ITEM 530 INTERSECTIONS, DRIVEWAYS, AND TURNOUTS
 ITEM 531 SIDEWALKS
 ITEM 533 MILLED RUMBLE STRIPS
 ITEM 540 METAL BEAM GUARD FENCE
 ITEM 542 REMOVING METAL BEAM GUARD FENCE
 ITEM 544 GUARDRAIL END TREATMENTS
 ITEM 545 CRASH CUSHION ATTENUATORS
 ITEM 618 CONDUIT (400)(476)
 ITEM 620 ELECTRICAL CONDUCTORS (610)(628)
 ITEM 624 GROUND BOXES <302>(420)(421)(432)(440)(618)(620)
 ITEM 628 ELECTRICAL SERVICES
 ITEM 644 SMALL ROADSIDE SIGN ASSEMBLIES
 ITEM 658 DELINEATOR AND OBJECT MARKER ASSEMBLIES
 ITEM 662 WORK ZONE PAVEMENT MARKINGS
 ITEM 666 RETROREFLECTORIZED PAVEMENT MARKINGS
 ITEM 672 RAISED PAVEMENT MARKERS
 ITEM 677 ELIMINATING EXISTING PAVEMENT MARKINGS AND MARKERS
 ITEM 678 PAVEMENT SURFACE PREPARATION FOR MARKINGS (677)
 ITEM 680 HIGHWAY TRAFFIC SIGNALS
 ITEM 681 TEMPORARY TRAFFIC SIGNALS
 ITEM 682 VEHICLE AND PEDESTRIAN SIGNAL HEADS
 ITEM 684 TRAFFIC SIGNAL CABLES
 ITEM 686 TRAFFIC SIGNAL POLE ASSEMBLIES (STEEL)
 ITEM 687 PEDESTAL POLE ASSEMBLIES
 ITEM 688 PEDESTRIAN DETECTORS AND VEHICLE LOOP DETECTORS
 ITEM 738 CLEANING AND SWEEPING HIGHWAYS

SPECIAL PROVISIONS: SPECIAL PROVISIONS WILL GOVERN AND TAKE
 ----- PRECEDENCE OVER THE SPECIFICATIONS ENUMERATED
 HEREON WHEREVER IN CONFLICT THEREWITH.

SPECIAL LABOR PROVISIONS FOR STATE PROJECTS (000---008)
 SPECIAL PROVISION "NONDISCRIMINATION" (000---002)
 SPECIAL PROVISION "SMALL BUSINESS ENTERPRISE IN STATE FUNDED PROJECTS
 " (000---009)
 SPECIAL PROVISION "CERTIFICATE OF INTERESTED PARTIES (FORM 1295)"
 (000--1019)
 SPECIAL PROVISION "SCHEDULE OF LIQUIDATED DAMAGES" (000--1243)
 SPECIAL PROVISION "IMPORTANT NOTICE TO CONTRACTORS" (000--1530)
 SPECIAL PROVISION "NOTICE OF CONTRACTOR PERFORMANCE EVALUATIONS"
 (000---659)
 SPECIAL PROVISIONS TO ITEM 2 (002---013)(002---014)(002---015)
 SPECIAL PROVISIONS TO ITEM 3 (003---011)(003---013)
 SPECIAL PROVISIONS TO ITEM 5 (005---002)(005---003)
 SPECIAL PROVISIONS TO ITEM 6 (006---001)(006---012)
 SPECIAL PROVISIONS TO ITEM 7 (007---004)(007---008)(007---010)
 (007---011)(007---013)
 SPECIAL PROVISIONS TO ITEM 8 (008---030)(008---033)(008---054)
 (008---056)
 SPECIAL PROVISIONS TO ITEM 9 (009---010)(009---016)

Control 0168-07-043, ETC.

Project C 168-7-43, ETC.

Highway US 60

County DEAF SMITH

SMALL BUSINESS ENTERPRISE REQUIREMENTS

The following goal for small business enterprises is established:

SBE
0.0%

CHILD SUPPORT STATEMENT

Under Section 231.006, Family Code, the vendor or applicant certifies that the individual or business entity named in this contract, bid, or application is not ineligible to receive the specified grant, loan, or payment and acknowledges that this contract may be terminated and payment may be withheld if this certification is inaccurate.

CONFLICT OF INTEREST CERTIFICATION

Pursuant to Texas Government Code Section 2261.252(b), the Department is prohibited from entering into contracts in which Department officers and employees have a financial interest.

By signing the Contract, the Contractor certifies that it is not prohibited from entering into a Contract with the Department as a result of a financial interest as defined under Texas Government Code Section 2261.252(b), and that it will exercise reasonable care and diligence to prevent any actions or conditions that could result in a conflict of interest with the Department.

The Contractor also certifies that none of the following individuals, nor any of their family members within the second degree of affinity or consanguinity, owns 1% or more interest or has a financial interest as defined under Texas Government Code Section 2261.252(b) in the Contractor:

- Any member of the Texas Transportation Commission; and
- The Department's Executive Director, General Counsel, Chief of Procurement and Field Support Operations, Director of Procurement, and Director of Contract Services.

Violation of this certification may result in action by the Department.

E-VERIFY CERTIFICATION

Pursuant to Texas Transportation Code §223.051, all TxDOT contracts for construction, maintenance, or improvement of a highway must include a provision requiring Contractors and subcontractors to use the U.S. Department of Homeland Security's E-Verify system to determine employment eligibility. By signing the contract, the Contractor certifies that prior to the award of the Contract:

- the Contractor has registered with and will, to the extent permitted by law, utilize the United States Department of Homeland Security's E-Verify system during the term of the Contract to determine the eligibility of all persons hired to perform duties within Texas during the term of the agreement; and
- the Contractor will require that all subcontractors also register with and, to the extent permitted by law, utilize the United States Department of Homeland Security's E-Verify system during the term of the subcontract to determine the eligibility of all persons hired to perform duties within Texas during the term of the agreement.

Violation of this requirement constitutes a material breach of the Contract, subjects a subcontractor to removal from the Contract, and subjects the Contractor or subcontractors to possible sanctions in accordance with Title 43, Texas Administrative Code, Chapter 10, Subchapter F, "Sanctions and Suspension for Ethical Violations by Entities Doing Business with the Department."

Certification Regarding Disclosure of Public Information

Pursuant to Subchapter J, Chapter 552, Texas Government Code, contractors executing a contract with a governmental body that results in the expenditure of at least \$1 million in public funds must:

- 1) preserve all contracting information* as provided by the records retention requirements applicable to Texas Department of Transportation (TxDOT) for the duration of the contract,
- 2) on request of TxDOT, promptly provide any contracting information related to the contract that is in the custody or possession of the entity, and
- 3) on completion of the contract, either:
 - A. provide, at no cost to TxDOT, all contracting information related to the contract that is in the custody or possession of the entity, or
 - B. preserve the contracting information related to the contract as provided by the records retention requirements applicable to TxDOT

The requirements of Subchapter J, Chapter 552, Government Code, may apply to this contract, and the contractor or vendor agrees that the contract can be terminated if the contractor or vendor knowingly or intentionally fails to comply with a requirement of that subchapter.

By entering into Contract, the Contractor agrees to:

- provide, or make available, to TxDOT and any authorized governmental investigating or auditing agency all records, including electronic and payment records related to the contract, for the same period provided by the records retention schedule applicable to TxDOT, and
- ensure that all subcontracts include a clause requiring the same.

* As defined in Government Code §552.003, “Contracting information” means the following information maintained by a governmental body or sent between a governmental body and a vendor, contractor, potential vendor, or potential contractor:

- 1) information in a voucher or contract relating to the receipt or expenditure of public funds by a governmental body;
- 2) solicitation or bid documents relating to a contract with a governmental body;
- 3) communications sent between a governmental body and a vendor, contractor, potential vendor, or potential contractor during the solicitation, evaluation, or negotiation of a contract;
- 4) documents, including bid tabulations, showing the criteria by which a governmental body evaluates each vendor, contractor, potential vendor, or potential contractor responding to a solicitation and, if applicable, an explanation of why the vendor or contractor was selected; and
- 5) communications and other information sent between a governmental body and a vendor or contractor related to the performance of a final contract with the governmental body or work performed on behalf of the governmental body.

CERTIFICATION TO NOT BOYCOTT ISRAEL

Pursuant to Texas Government Code §2271.002, the Department must include a provision requiring a written verification affirming that the Contractor does not boycott Israel, as defined in Government Code §808.001, and will not boycott Israel during the term of the contract. This provision applies to a contract that:

- 1) is with a Contractor that is not a sole proprietorship,
- 2) is with a Contractor with 10 or more full-time employees, and
- 3) has a value of \$100,000 or more.

By signing the contract, the Contractor certifies that it does not boycott Israel and will not boycott Israel during the term of this contract. "Boycott" means refusing to deal with, terminating business activities with, or otherwise taking any action that is intended to penalize, inflict economic harm on, or limit commercial relations specifically with Israel, or with a person or entity doing business in Israel or in an Israeli-controlled territory, but does not include an action made for ordinary business purposes.

Violation of this certification may result in action by the Department.

CERTIFICATION TO NOT BOYCOTT ENERGY COMPANIES

Pursuant to Texas Government Code §2274.002, the Department must include a provision requiring a written verification affirming that the Contractor does not boycott energy companies, as defined in Government Code §809.001, and will not boycott energy companies during the term of the contract. This provision applies to a contract that:

- 1) is with a Contractor that is not a sole proprietorship,
- 2) is with a Contractor with 10 or more full-time employees, and
- 3) has a value of \$100,000 or more.

By signing the contract, the Contractor certifies that it does not boycott energy companies and will not boycott energy companies during the term of this contract. "Boycott" means taking any action that is intended to penalize, inflict economic harm on, or limit commercial relations with a company because the company: (1) engages in the exploration, production, utilization, transportation, sale, or manufacturing of fossil fuel-based energy and does not commit or pledge to meet environmental standards beyond applicable federal and state law; or (2) does business with a company described by (1).

Violation of this certification may result in action by the Department.

CERTIFICATION TO NOT DISCRIMINATE AGAINST FIREARM ENTITIES OR FIREARM TRADE ASSOCIATIONS

Pursuant to Texas Government Code §2274.002, the Department must include a provision requiring a written verification affirming that the Contractor:

- 1) does not have a practice, policy, guidance, or directive that discriminates against a firearm entity or firearm trade association, as defined in Government Code §2274.001, and
- 2) will not discriminate against a firearm entity or firearm trade association during the term of the contract.

This provision applies to a contract that:

- 1) is with a Contractor that is not a sole proprietorship,
- 2) is with a Contractor with 10 or more full-time employees, and
- 3) has a value of \$100,000 or more.

By signing the contract, the Contractor certifies that it does not discriminate against a firearm entity or firearm trade association as described and will not do so during the term of this contract. "Discriminate against a firearm entity or firearm trade association" means, with respect to the entity or association, to: (1) refuse to engage in the trade of any goods or services with the entity or association based solely on its status as a firearm entity or firearm trade association; (2) refrain from continuing an existing business relationship with the entity or association based solely on its status as a firearm entity or firearm trade association; or (3) terminate an existing business relationship with the entity or association based solely on its status as a firearm entity or firearm trade association. "Discriminate against a firearm entity or firearm trade association" does not include: (1) the established policies of a merchant, retail seller, or platform that restrict or prohibit the listing or selling of ammunition, firearms, or firearm accessories; (2) a company's refusal to engage in the trade of any goods or services, decision to refrain from continuing an existing business relationship, or decision to terminate an existing business relationship to comply with federal, state, or local law, policy, or regulations or a directive by a regulatory agency, or for any traditional business reason that is specific to the customer or potential customer and not based solely on an entity's or association's status as a firearm entity or firearm trade association.

Violation of this certification may result in action by the Department.

PROHIBITION ON CERTAIN TELECOMMUNICATIONS EQUIPMENT OR SERVICES

The Federal Register Notice issued the Final Rule and states that the amendment to 2 CFR 200.216 is effective on August 13, 2020. The new 2 CFR 200.471 regulation provides clarity that the telecommunications and video surveillance costs associated with 2 CFR 200.216 are unallowable for services and equipment from these specific providers. OMB's Federal Register Notice includes the new 2 CFR 200.216 and 2 CFR 200.471 regulations.

<https://www.federalregister.gov/documents/2020/08/13/2020-17468/guidance-for-grants-and-agreements>

Per the Federal Law referenced above, use of services, systems, or services or systems that contain components produced by any of the following manufacturers is strictly prohibited for use on this project. Therefore, for any telecommunications, CCTV, or video surveillance equipment, services or systems cannot be manufactured by, or have components manufactured by:

- Huawei Technologies Company,
- ZTE Corporation (any subsidiary and affiliate of such entities),
- Hyatera Communications Corporation,
- Hangzhou Hikvision Digital Technology Company,
- Dahua Technology Company (any subsidiary and affiliate of such entities).

Violation of this prohibition will require replacement of the equipment at the contractor's expense.

Special Provision to Item 000

Special Labor Provisions for State Projects



1. GENERAL

This is a "Public Works" Project, as provided under Government Code Title 10, Chapter 2258, "Prevailing Wage Rates," and is subject to the provisions of the Statute. No provisions in the Contract are intended to be in conflict with the provisions of the Statute.

The Texas Transportation Commission has ascertained and indicated in the special provisions the regular rate of per diem wages prevailing in each locality for each craft or type of worker. Apply the wage rates contained in the specifications as minimum wage rates for the Contract.

2. MINIMUM WAGES, HOURS AND CONDITIONS OF EMPLOYMENT

All workers necessary for the satisfactory completion of the work are within the purview of the Contract.

Whenever and wherever practical, give local citizens preference in the selection of labor.

Do not require any worker to lodge, board or trade at a particular place, or with a particular person as a condition of employment.

Do not charge or accept a fee of any from any person who obtains work on the project. Do not require any person who obtains work on the project to pay any fee to any other person or agency obtaining employment for the person on the project.

Do not charge for tools or equipment used in connection with the duties performed, except for loss or damage of property. Do not charge for necessary camp water.

Do not charge for any transportation furnished to any person employed on the project.

The provisions apply where work is performed by piece work, station work, etc. The minimum wage paid will be exclusive of equipment rental on any shipment which the worker or subcontractor may furnish in connection with his work.

Take responsibility for carrying out the requirements of this specification and ensure that each subcontractor working on the project complies with its provisions.

Any form of subterfuge, coercion or deduction designated to evade, reduce or discount the established minimum wage scales will be considered a violation of the Contract.

The Fair Labor Standards Acts (FLSA) established one and one-half (1-1/2) pay for overtime in excess of 40 hours worked in 1 week. Do not consider time consumed by the worker in going to and returning from the place of work as part of the hours of work. Do not require or permit any worker to work in excess of 40 hours in 1 week, unless the worker receives compensation at a rate not less than 1-1/2 times the basic rate of pay for all hours worked in excess of 40 hours in the workweek.

The general rates of per diem wages prevailing in this locality for each class and type of workers whose services are considered necessary to fulfill the Contract are indicated in the special provisions, and these rates govern as minimum wage rates on this Contract. A penalty of \$60.00 per calendar day or portion of a calendar day for each worker that is paid less than the stipulated general rates of per diem wages for any work done under the Contract will be deducted. The Department, upon receipt of a complaint by a worker,

will determine within 30 days whether good cause exists to believe that the Contractor or a subcontractor has violated wage rate requirements and notify the parties involved of the findings. Make every effort to resolve the alleged violation within 14 days after notification. The next alternative is submittal to binding arbitration in accordance with the provisions of the Texas General Arbitration Act (Art. 224 et seq., Revised Statutes).

Notwithstanding any other provision of the Contract, covenant and agree that the Contractor and its subcontractors will pay each of their employees and contract labor engaged in any way in work under the Contract, a wage not less than what is generally known as the "federal minimum wage" as set out in 29 U.S.C. 206 as that Statute may be amended from time to time.

Pay any worker employed whose position is not listed in the Contract, a wage not less than the per diem wage rate established in the Contract for a worker whose duties are most nearly comparable.

3. RECORD AND INSPECTIONS

Keep copies of weekly payrolls for review. Require subcontractors to keep copies of weekly payrolls for review. Show the name, occupation, number of hours worked each day and per diem wage paid each worker together with a complete record of all deductions made from such wages. Keep records for a period of 3 years from the date of completion of the Contract.

Where the piece-work method is used, indicate on the payroll for each person involved:

- Quantity of piece work performed.
- Price paid per piece-work unit.
- Total hours employed.

The Engineer may require the Contractor to file an affidavit for each payroll certifying that payroll is a true and accurate report of the full wages due and paid to each person employed.

Post or make available to employees the prevailing wage rates from the Contract. Require subcontractors to post or make available to employees the prevailing wage rates from the Contract.

The wage rates listed herein are those predetermined by the Secretary of Labor and State Statute and listed in the United States Department of Labor's (USDOL) General Decisions dated 01-05-2024 and are the minimum wages to be paid accordingly for each specified classification. To determine the applicable wage rate zone, a list entitled "TEXAS COUNTIES IDENTIFIED BY WAGE RATE ZONES" is provided in the contract. Any wage rate that is not listed herein and not in the USDOL's general decision, must be requested by the contractor through the completion of an Additional Classification and Wage Rate Request and be submitted for approval. IMPORTANT NOTICE FOR STATE PROJECTS: only the controlling wage rate zone applies to the contract. Effective 01-05-2024.

CLASS. #	CLASSIFICATION DESCRIPTION	ZONE TX02 *(TX20240002)	ZONE TX03 *(TX20240003)	ZONE TX04 *(TX20240004)	ZONE TX05 *(TX20240005)	ZONE TX06 *(TX20240006)	ZONE TX07 *(TX20240007)	ZONE TX08 *(TX20240008)	ZONE TX24 *(TX20240024)	ZONE TX25 *(TX20240025)	ZONE TX27 *(TX20240027)	ZONE TX28 *(TX20240028)	ZONE TX29 *(TX20240029)	ZONE TX30 *(TX20240030)	ZONE TX37 *(TX20240037)	ZONE TX38 *(TX20240038)	ZONE TX42 *(TX20240042)
1428	Agricultural Tractor Operator						\$12.69					\$12.35			\$11.75		
1300	Asphalt Distributor Operator	\$14.87	\$13.48	\$13.88	\$15.72	\$15.58	\$15.55	\$15.72	\$13.28	\$15.32	\$15.62	\$14.36	\$14.25	\$14.03	\$13.75	\$14.06	\$14.40
1303	Asphalt Paving Machine Operator	\$13.40	\$12.25	\$12.35	\$13.87	\$14.05	\$14.36	\$14.20	\$13.26	\$13.99	\$14.68	\$12.92	\$13.44	\$12.53	\$14.00	\$14.32	\$12.99
1106	Asphalt Raker	\$12.28	\$10.61	\$12.02	\$14.21	\$11.65	\$12.12	\$11.64	\$11.44	\$12.69	\$12.05	\$11.34	\$11.67	\$11.40	\$12.59	\$12.36	\$11.78
1112	Batching Plant Operator, Asphalt																
1115	Batching Plant Operator, Concrete																
1214	Blaster																
1615	Boom Truck Operator						\$18.36										
1444	Boring Machine Operator																
1305	Broom or Sweeper Operator	\$11.21	\$10.33	\$10.08	\$11.99		\$11.04	\$11.62		\$11.74	\$11.41	\$10.30		\$10.23	\$10.60	\$12.68	\$11.05
1144	Communications Cable Installer																
1124	Concrete Finisher, Paving and Structures	\$13.55	\$12.46	\$13.16	\$12.85	\$12.64	\$12.56	\$12.77	\$12.44	\$14.12	\$13.04	\$13.38	\$12.64	\$12.80	\$12.79	\$12.98	\$13.32
1318	Concrete Pavement Finishing Machine Operator				\$16.05		\$15.48			\$16.05		\$19.31				\$13.07	
1315	Concrete Paving, Curing, Float, Texturing Machine Operator											\$16.34				\$11.71	
1333	Concrete Saw Operator				\$14.67					\$14.48	\$17.33					\$13.99	
1399	Concrete/Gunite Pump Operator																
1344	Crane Operator, Hydraulic 80 tons or less				\$18.22		\$18.36			\$18.12	\$18.04	\$20.21			\$18.63	\$13.86	
1345	Crane Operator, Hydraulic Over 80 Tons																
1342	Crane Operator, Lattice Boom 80 Tons or Less	\$16.82	\$14.39	\$13.85	\$17.27		\$15.87			\$17.27		\$14.67			\$16.42	\$14.97	\$13.87
1343	Crane Operator, Lattice Boom Over 80 Tons				\$20.52		\$19.38			\$20.52		\$17.49			\$25.13	\$15.80	
1306	Crawler Tractor Operator	\$13.96	\$16.63	\$13.62	\$14.26		\$15.67			\$14.07	\$13.15	\$13.38			\$14.60	\$13.68	\$13.50
1351	Crusher or Screen Plant Operator																
1446	Directional Drilling Locator						\$11.67										
1445	Directional Drilling Operator				\$20.32		\$17.24										
1139	Electrician	\$20.96		\$19.87	\$19.80		\$26.35		\$20.27	\$19.80		\$20.92				\$27.11	\$19.87
1347	Excavator Operator, 50,000 pounds or less	\$13.46	\$12.56	\$13.67	\$17.19		\$12.88	\$14.38	\$13.49	\$17.19		\$13.88			\$14.09	\$12.71	\$14.42
1348	Excavator Operator, Over 50,000 pounds		\$15.23	\$13.52	\$17.04		\$17.71			\$16.99	\$18.80	\$16.22				\$14.53	\$13.52
1150	Flagger	\$9.30	\$9.10	\$8.50	\$10.28	\$8.81	\$9.45	\$8.70		\$10.06	\$9.71	\$9.03	\$8.81	\$9.08	\$9.90	\$10.33	\$8.10
1151	Form Builder/Setter, Structures	\$13.52	\$12.30	\$13.38	\$12.91	\$12.71	\$12.87	\$12.38	\$12.26	\$13.84	\$12.98	\$13.07	\$13.61	\$12.82	\$14.73	\$12.23	\$12.25
1160	Form Setter, Paving & Curb	\$12.36	\$12.16	\$13.93	\$11.83	\$10.71	\$12.94			\$13.16	\$12.54	\$11.33	\$10.69		\$13.33	\$12.34	\$13.93
1360	Foundation Drill Operator, Crawler Mounted				\$17.99					\$17.99						\$17.43	
1363	Foundation Drill Operator, Truck Mounted		\$16.86	\$22.05	\$21.51		\$16.93			\$21.07	\$20.20	\$20.76		\$17.54	\$21.39	\$15.89	\$22.05
1369	Front End Loader Operator, 3 CY or Less	\$12.28	\$13.49	\$13.40	\$13.85		\$13.04	\$13.15	\$13.29	\$13.69	\$12.64	\$12.89			\$13.51	\$13.32	\$12.17
1372	Front End Loader Operator, Over 3 CY	\$12.77	\$13.69	\$12.33	\$14.96		\$13.21	\$12.86	\$13.57	\$14.72	\$13.75	\$12.32			\$13.19	\$13.17	\$13.02
1329	Joint Sealer																
1172	Laborer, Common	\$10.30	\$9.86	\$10.08	\$10.51	\$10.71	\$10.50	\$10.24	\$10.58	\$10.72	\$10.45	\$10.30	\$10.25	\$10.03	\$10.54	\$11.02	\$10.15
1175	Laborer, Utility	\$11.80	\$11.53	\$12.70	\$12.17	\$11.81	\$12.27	\$12.11	\$11.33	\$12.32	\$11.80	\$11.53	\$11.23	\$11.50	\$11.95	\$11.73	\$12.37
1346	Loader/Backhoe Operator	\$14.18	\$12.77	\$12.97	\$15.68		\$14.12			\$15.18	\$13.58	\$12.87		\$13.21	\$14.13	\$14.29	\$12.90
1187	Mechanic	\$20.14	\$15.47	\$17.47	\$17.74	\$17.00	\$17.10			\$17.68	\$18.94	\$18.58	\$17.00	\$16.61	\$18.46	\$16.96	\$17.47

CLASS. #	CLASSIFICATION DESCRIPTION	ZONE TX02 (TX20240002)	ZONE TX03 (TX20240003)	ZONE TX04 (TX20240004)	ZONE TX05 (TX20240005)	ZONE TX06 (TX20240006)	ZONE TX07 (TX20240007)	ZONE TX08 (TX20240008)	ZONE TX24 (TX20240024)	ZONE TX25 (TX20240025)	ZONE TX27 (TX20240027)	ZONE TX28 (TX20240028)	ZONE TX29 (TX20240029)	ZONE TX30 (TX20240030)	ZONE TX37 (TX20240037)	ZONE TX38 (TX20240038)	ZONE TX42 (TX20240042)
1380	Milling Machine Operator Motor Grader Operator,	\$15.54	\$14.64	\$12.22	\$14.29		\$14.18			\$14.32	\$14.35	\$12.86			\$14.75	\$13.53	\$12.80
1390	Fine Grade	\$17.49	\$16.52	\$16.88	\$17.12	\$18.37	\$18.51	\$16.69	\$16.13	\$17.19	\$18.35	\$17.07	\$17.74	\$17.47	\$17.08	\$15.69	\$20.01
1393	Motor Grader Operator, Rough	\$16.15	\$14.62	\$15.83	\$16.20	\$17.07	\$14.63	\$18.50		\$16.02	\$16.44	\$15.12	\$16.85	\$14.47	\$17.39	\$14.23	\$15.53
1413	Off Road Hauler			\$10.08	\$12.26		\$11.88			\$12.25		\$12.23			\$13.00	\$14.60	
1196	Painter, Structures Pavement Marking Machine Operator					\$21.29	\$18.34						\$21.29			\$18.62	
1396	Operator	\$16.42		\$13.10	\$13.55		\$19.17	\$12.01		\$13.63	\$14.60	\$13.17		\$16.65	\$10.54	\$11.18	\$13.10
1443	Percussion or Rotary Drill Operator																
1202	Piledriver															\$14.95	
1205	Pipelayer		\$11.87	\$14.64	\$13.17	\$11.17	\$12.79		\$11.37	\$13.24	\$12.66	\$13.24	\$11.17	\$11.67		\$12.12	\$14.64
1384	Reclaimer/Pulverizer Operator	\$12.85			\$11.90		\$12.88			\$11.01		\$10.46					
1500	Reinforcing Steel Worker	\$13.50	\$14.07	\$17.53	\$16.17		\$14.00			\$16.18	\$12.74	\$15.83		\$17.10		\$15.15	\$17.72
1402	Roller Operator, Asphalt	\$10.95		\$11.96	\$13.29		\$12.78	\$11.61		\$13.08	\$12.36	\$11.68			\$11.71	\$11.95	\$11.50
1405	Roller Operator, Other	\$10.36		\$10.44	\$11.82		\$10.50	\$11.64		\$11.51	\$10.59	\$10.30		\$12.04	\$12.85	\$11.57	\$10.66
1411	Scraper Operator	\$10.61	\$11.07	\$10.85	\$12.88		\$12.27		\$11.12	\$12.96	\$11.88	\$12.43		\$11.22	\$13.95	\$13.47	\$10.89
1417	Self-Propelled Hammer Operator																
1194	Servicer	\$13.98	\$12.34	\$14.11	\$14.74		\$14.51	\$15.56	\$13.44	\$14.58	\$14.31	\$13.83		\$12.43	\$13.72	\$13.97	\$14.11
1513	Sign Erector Slurry Seal or Micro-Surfacing Machine Operator																
1708	Machine Operator																
1341	Small Slipform Machine Operator									\$15.96							
1515	Spreader Box Operator	\$12.60		\$13.12	\$14.71		\$14.04			\$14.73	\$13.84	\$13.68		\$13.45	\$11.83	\$13.58	\$14.05
1705	Structural Steel Welder															\$12.85	
1509	Structural Steel Worker						\$19.29									\$14.39	
1339	Subgrade Trimmer																
1143	Telecommunication Technician																
1145	Traffic Signal/Light Pole Worker Trenching Machine Operator,						\$16.00										
1440	Heavy						\$18.48										
1437	Trenching Machine Operator, Light																
1609	Truck Driver Lowboy-Float	\$14.46	\$13.63	\$13.41	\$15.00	\$15.93	\$15.66			\$16.24	\$16.39	\$14.30	\$16.62	\$15.63	\$14.28	\$16.03	\$13.41
1612	Truck Driver Transit-Mix				\$14.14					\$14.14							
1600	Truck Driver, Single Axle Truck Driver, Single or Tandem Axle Dump Truck	\$12.74	\$10.82	\$10.75	\$13.04	\$11.61	\$11.79	\$13.53	\$13.16	\$12.31	\$13.40	\$10.30	\$11.61		\$11.97	\$11.46	\$10.75
1606	Truck Driver, Tandem Axle Tractor with Semi Trailer	\$11.33	\$14.53	\$11.95	\$12.95		\$11.68		\$14.06	\$12.62	\$11.45	\$12.28		\$13.08	\$11.68	\$11.48	\$11.10
1607	Tunneling Machine Operator, Heavy	\$12.49	\$12.12	\$12.50	\$13.42		\$12.81	\$13.16		\$12.86	\$16.22	\$12.50			\$13.80	\$12.27	\$12.50
1441	Tunneling Machine Operator, Light																
1706	Welder		\$14.02		\$14.86		\$15.97		\$13.74	\$14.84					\$13.78		
1520	Work Zone Barricade Servicer	\$10.30	\$12.88	\$11.46	\$11.70	\$11.57	\$11.85	\$10.77		\$11.68	\$12.20	\$11.22	\$11.51	\$12.96	\$10.54	\$11.67	\$11.76

Notes:

*Represents the USDOL wage decision.

Any worker employed on this project shall be paid at the rate of one and one half (1-1/2) times the regular rate for every hour worked in excess of forty (40) hours per week.

For reference, the titles and descriptions for the classifications listed here are detailed further in the AGC of Texas' *Standard Job Classifications and Descriptions for Highway, Heavy, Utilities, and Industrial Construction in Texas* posted on the AGC's Web site for any contractor.

**TEXAS COUNTIES IDENTIFIED BY
WAGE RATE ZONES: 2, 3, 4, 5, 6, 7, 8, 24, 25, 27, 28, 29, 30, 37, 38, 42**

County Name	Zone	County Name	Zone	County Name	Zone	County Name	Zone
Anderson	28	Donley	37	Karnes	27	Reagan	37
Andrews	37	Duval	30	Kaufman	25	Real	37
Angelina	28	Eastland	37	Kendall	7	Red River	28
Aransas	29	Ector	2	Kenedy	30	Reeves	8
Archer	25	Edwards	8	Kent	37	Refugio	27
Armstrong	2	El Paso	24	Kerr	27	Roberts	37
Atascosa	7	Ellis	25	Kimble	37	Robertson	7
Austin	38	Erath	28	King	37	Rockwall	25
Bailey	37	Falls	28	Kinney	8	Runnels	37
Bandera	7	Fannin	28	Kleberg	27	Rusk	4
Bastrop	7	Fayette	27	Knox	37	Sabine	28
Baylor	37	Fisher	37	Lamar	28	San Augustine	28
Bee	27	Floyd	37	Lamb	37	San Jacinto	38
Bell	7	Foard	37	Lampasas	7	San Patricio	29
Bexar	7	Fort Bend	38	LaSalle	30	San Saba	37
Blanco	27	Franklin	28	Lavaca	27	Schleicher	37
Borden	37	Freestone	28	Lee	27	Scurry	37
Bosque	28	Frio	27	Leon	28	Shackelford	37
Bowie	4	Gaines	37	Liberty	38	Shelby	28
Brazoria	38	Galveston	38	Limestone	28	Sherman	37
Brazos	7	Garza	37	Lipscomb	37	Smith	4
Brewster	8	Gillespie	27	Live Oak	27	Somervell	28
Briscoe	37	Glasscock	37	Llano	27	Starr	30
Brooks	30	Goliad	29	Loving	37	Stephens	37
Brown	37	Gonzales	27	Lubbock	2	Sterling	37
Burleson	7	Gray	37	Lynn	37	Stonewall	37
Burnet	27	Grayson	25	Madison	28	Sutton	8
Caldwell	7	Gregg	4	Marion	28	Swisher	37
Calhoun	29	Grimes	28	Martin	37	Tarrant	25
Callahan	25	Guadalupe	7	Mason	27	Taylor	2
Cameron	3	Hale	37	Matagorda	27	Terrell	8
Camp	28	Hall	37	Maverick	30	Terry	37
Carson	2	Hamilton	28	McCulloch	37	Throckmorton	37
Cass	28	Hansford	37	McLennan	7	Titus	28
Castro	37	Hardeman	37	McMullen	30	Tom Green	2
Chambers	38	Hardin	38	Medina	7	Travis	7
Cherokee	28	Harris	38	Menard	37	Trinity	28
Childress	37	Harrison	42	Midland	2	Tyler	28
Clay	25	Hartley	37	Milam	28	Upshur	4
Cochran	37	Haskell	37	Mills	37	Upton	37
Coke	37	Hays	7	Mitchell	37	Uvalde	30
Coleman	37	Hemphill	37	Montague	37	Val Verde	8
Collin	25	Henderson	28	Montgomery	38	Van Zandt	28
Collingsworth	37	Hidalgo	3	Moore	37	Victoria	6
Colorado	27	Hill	28	Morris	28	Walker	28
Comal	7	Hockley	37	Motley	37	Waller	38
Comanche	37	Hood	28	Nacogdoches	28	Ward	37
Concho	37	Hopkins	28	Navarro	28	Washington	28
Cooke	37	Houston	28	Newton	28	Webb	3
Coryell	7	Howard	37	Nolan	37	Wharton	27
Cottle	37	Hudspeth	8	Nueces	29	Wheeler	37
Crane	37	Hunt	25	Ochiltree	37	Wichita	5
Crockett	8	Hutchinson	37	Oldham	37	Wilbarger	37
Crosby	2	Irion	2	Orange	38	Willacy	30
Culberson	8	Jack	28	Palo Pinto	28	Williamson	7
Dallam	37	Jackson	27	Panola	28	Wilson	7
Dallas	25	Jasper	28	Parker	25	Winkler	37
Dawson	37	Jeff Davis	8	Parmer	37	Wise	25
Deaf Smith	37	Jefferson	38	Pecos	8	Wood	28
Delta	25	Jim Hogg	30	Polk	28	Yoakum	37
Denton	25	Jim Wells	27	Potter	2	Young	37
DeWitt	27	Johnson	25	Presidio	8	Zapata	30
Dickens	37	Jones	25	Rains	28	Zavala	30
Dimmit	30			Randall	2		

Special Provision to Item 000

Nondiscrimination



1. DESCRIPTION

All recipients of federal financial assistance are required to comply with various nondiscrimination laws including Title VI of the Civil Rights Act of 1964, as amended, (Title VI). Title VI forbids discrimination against anyone in the United States on the grounds of race, color, or national origin by any agency receiving federal funds.

Texas Department of Transportation, as a recipient of Federal financial assistance, and under Title VI and related statutes, ensures that no person shall on the grounds of race, religion (where the primary objective of the financial assistance is to provide employment per 42 U.S.C. § 2000d-3), color, national origin, sex, age or disability be excluded from participation in, be denied the benefits of, or otherwise be subjected to discrimination under any Department programs or activities.

2. DEFINITION OF TERMS

Where the term “contractor” appears in the following six nondiscrimination clauses, the term “contractor” is understood to include all parties to contracts or agreements with the Texas Department of Transportation.

3. NONDISCRIMINATION PROVISIONS

During the performance of this contract, the contractor agrees as follows:

- 3.1. **Compliance with Regulations.** The Contractor shall comply with the Regulations relative to nondiscrimination in Federally-assisted programs of the Department of Transportation (hereinafter, “DOT”) Title 49, Code of Federal Regulations, Part 21, as they may be amended from time to time, (hereinafter referred to as the Regulations), which are herein incorporated by reference and made a part of this contract.
- 3.2. **Nondiscrimination.** The contractor, with regard to the work performed by it during the contract, shall not discriminate on the grounds of race, color, or national origin in the selection and retention of subcontractors, including procurements of materials and leases of equipment. The contractor shall not participate either directly or indirectly in the discrimination prohibited by section 21.5 of the Regulations, including employment practices when the contract covers a program set forth in Appendix B of the Regulations.
- 3.3. **Solicitations for Subcontracts, Including Procurements of Materials and Equipment:** In all solicitations either by competitive bidding or negotiation made by the contractor for work to be performed under a subcontract, including procurements of materials or leases of equipment, each potential subcontractor or supplier shall be notified by the contractor of the contractor's obligations under this contract and the Regulations relative to nondiscrimination on the grounds of race, color, or national origin.
- 3.4. **Information and Reports:** The contractor shall provide all information and reports required by the Regulations or directives issued pursuant thereto, and shall permit access to its books, records, accounts, other sources of information, and its facilities as may be determined by the Recipient or the Texas Department of Transportation to be pertinent to ascertain compliance with such Regulations, orders and instructions. Where any information required of a contractor is in the exclusive possession of another who fails or refuses to furnish this information the contractor shall so certify to the Recipient, or the Texas Department of Transportation as appropriate, and shall set forth what efforts it has made to obtain the information.

- 3.5. **Sanctions for Noncompliance.** In the event of the contractor's noncompliance with the nondiscrimination provisions of this contract, the Recipient shall impose such contract sanctions as it or the Texas Department of Transportation may determine to be appropriate, including, but not limited to:
- withholding of payments to the contractor under the contract until the contractor complies, and/or
 - cancellation, termination or suspension of the contract, in whole or in part.
- 3.6. **Incorporation of Provisions.** The contractor shall include the provisions of paragraphs (1) through (6) in every subcontract, including procurements of materials and leases of equipment, unless exempt by the Regulations, or directives issued pursuant thereto. The contractor shall take such action with respect to any subcontract or procurement as the Recipient or the Texas Department of Transportation may direct as a means of enforcing such provisions including sanctions for non-compliance: Provided, however, that, in the event a contractor becomes involved in, or is threatened with, litigation with a subcontractor or supplier as a result of such direction, the contractor may request the Recipient to enter into such litigation to protect the interests of the Recipient, and, in addition, the contractor may request the United States to enter into such litigation to protect the interests of the United States.

Special Provision to Item 000

Small Business Enterprise in State Funded Projects



1. DESCRIPTION

The purpose of this Special Provision is to carry out the Texas Department of Transportation's policy of ensuring that Small Business Enterprise (SBE) has an opportunity to participate in the performance of contracts. If the SBE goal is greater than zero, Article A of this Special Provision shall apply to this Contract; otherwise, Article B of this Special Provision applies. The percentage goal for SBE participation in the work to be performed under this contract will be shown in the proposal.

2. DEFINITIONS

Small Business Enterprise (SBE) is a firm (including affiliates) certified by the Department whose annual gross receipts do not exceed the U.S. Small Business Administration's size standards for 4 consecutive years. Firms certified as Historically Underutilized Businesses (HUBs) by the Texas Comptroller of Public Accounts and as Disadvantaged Business Enterprises (DBEs) by the Texas Uniform Certification Program automatically qualify as SBEs.

2.1. Article A - SBE Goal is Greater than Zero.

2.1.1. **Policy.** The Department is committed to providing contracting opportunities for small businesses. In this regard, it is the Department's policy to develop and maintain a program in order to facilitate contracting opportunities for small businesses. Consequently, the requirements of the Department's Small Business Enterprise Program apply to this contract as follows:

2.1.1.1. The Contractor shall make a good faith effort to meet the SBE goal for this contract.

2.1.1.2. The Contractor and any Subcontractors shall not discriminate on the basis of race, color, national origin, age, disability or sex in the award and performance of this contract. These nondiscrimination requirements shall be incorporated into any subcontract and purchase order.

2.1.1.3. After a conditional award is made to the low bidder, the Department will determine the adequacy of a Contractor's efforts to meet the contract goal, as is outlined under Section 2, "Contractor's Responsibilities." If the requirements of Section 2 are met, the contract will be forwarded to the Contractor for execution.

The Contractor's performance, during the construction period of the contract in meeting the SBE goal, will be monitored by the Department.

2.1.2. **Contractor's Responsibilities.** These requirements must be satisfied by the Contractor. A SBE Contractor may satisfy the SBE requirements by performing at least 25% of the contract work with its own organization as defined elsewhere in the contract.

2.1.2.1. The Contractor shall submit a completed SBE Commitment Agreement Form for each SBE they intend to use to satisfy the SBE goal so as to arrive in the Department's Office of Civil Rights (OCR) in Austin, Texas not later than 5:00 p.m. on the 10th business day, excluding national holidays, after the conditional award of the contract. When requested, additional time, not to exceed 7 business days, excluding national holidays, may be granted based on documentation submitted by the Contractor.

2.1.2.2. A Contractor who cannot meet the contract goal, in whole or in part, shall document the good faith efforts taken to meet the SBE goal. The Department will consider as good faith efforts all documented explanations

that are submitted and that describe a Contractor's failure to meet a SBE goal or obtain SBE participation, including:

- 2.1.2.2.1. Advertising in general circulation, trade association, and/or minority/women focus media concerning subcontracting opportunities,
- 2.1.2.2.2. Dividing the contract work into reasonable portions in accordance with standard industry practices,
- 2.1.2.2.3. Documenting reasons for rejection or meeting with the rejected SBE to discuss the rejection,
- 2.1.2.2.4. Providing qualified SBEs with adequate information about bonding, insurance, plans, specifications, scope of work, and the requirements of the contract,
- 2.1.2.2.5. Negotiating in good faith with qualified SBEs, not rejecting qualified SBEs who are also the lowest responsive bidder, and;
- 2.1.2.2.6. Using the services of available minorities and women, community organizations, contractor groups, local, state and federal business assistance offices, and other organizations that provide support services to SBEs.
- 2.1.2.3. The good faith effort documentation is due at the time and place specified in Subarticle 2.(a). of this Special Provision. The Director of the DBE & SBE Programs Section will evaluate the Contractor's documentation. If it is determined that the Contractor has failed to meet the good faith effort requirements, the Contractor will be given an opportunity for reconsideration by the Department.
- 2.1.2.4. Should the bidder to whom the contract is conditionally awarded refuse, neglect or fail to meet the SBE goal and/or demonstrate to the Department's satisfaction sufficient efforts to obtain SBE participation, the proposal guaranty filed with the bid shall become the property of the State, not as a penalty, but as liquidated damages to the Department.
- 2.1.2.5. The Contractor must not terminate a SBE subcontractor submitted on a commitment agreement for a contract with an assigned goal without the prior written consent of the Department.
- 2.1.2.6. The Contractor shall designate a SBE contact person who will administer the Contractor's SBE program and who will be responsible for submitting reports, maintaining records, and documenting good faith efforts to use SBEs.
- 2.1.2.7. The Contractor must inform the Department of the representative's name, title and telephone number within 10 days of beginning work.
- 2.1.3. **Eligibility of SBEs.**
- 2.1.3.1. The Department certifies the eligibility of SBEs.
- 2.1.3.2. The Department maintains and makes available to interested parties a directory of certified SBEs.
- 2.1.3.3. Only firms certified at the time of letting or at the time the commitments are submitted are eligible to be used in the information furnished by the Contractor required under Section 2.(a) above.
- 2.1.3.4. Certified HUBs and DBEs are eligible as SBEs.
- 2.1.3.5. Small Business Size Regulations and Eligibility is referenced on e-CFR (Code of Federal Regulations), Title 13 – Business Credit and Assistance, Chapter 1 – Small Business Administration, Part 121 – Small Business Size Regulations, Subpart A – Size Eligibility Provisions and Standards.
- 2.1.4. **Determination of SBE Participation.** SBE participation shall be counted toward meeting the SBE goal in this contract in accordance with the following:

- 2.1.4.1. A Contractor will receive credit for all payments actually made to a SBE for work performed and costs incurred in accordance with the contract, including all subcontracted work.
- 2.1.4.2. A SBE Contractor or subcontractor may not subcontract more than 75% of a contract. The SBE shall perform not less than 25% of the value of the contract work with its own organization.
- 2.1.4.3. A SBE may lease equipment consistent with standard industry practice. A SBE may lease equipment from the prime contractor if a rental agreement, separate from the subcontract specifying the terms of the lease arrangement, is approved by the Department prior to the SBE starting the work in accordance with the following:
- 2.1.4.3.1. If the equipment is of a specialized nature, the lease may include the operator. If the practice is generally acceptable with the industry, the operator may remain on the lessor's payroll. The operator of the equipment shall be subject to the full control of the SBE, for a short term, and involve a specialized piece of heavy equipment readily available at the job site.
- 2.1.4.3.2. For equipment that is not specialized, the SBE shall provide the operator and be responsible for all payroll and labor compliance requirements.
- 2.1.5. **Records and Reports.**
- 2.1.5.1. The Contractor shall submit monthly reports, after work begins, on SBE payments, (including payments to HUBs and DBEs). The monthly reports are to be sent to the Area Engineer's office. These reports will be due within 15 days after the end of a calendar month.
- These reports will be required until all SBE subcontracting or supply activity is completed. The "SBE Progress Report" is to be used for monthly reporting. Upon completion of the contract and prior to receiving the final payment, the Contractor shall submit the "SBE Final Report" to the Office of Civil Rights and a copy to the Area Engineer. These forms may be obtained from the Office of Civil Rights and reproduced as necessary. The Department may verify the amounts being reported as paid to SBEs by requesting, on a random basis, copies of invoices and cancelled checks paid to SBEs. When the SBE goal requirement is not met, documentation supporting Good Faith Efforts, as outlined in Section 2.(b) of this Special Provision, must be submitted with the Final Report.
- 2.1.5.2. SBE subcontractors and/or suppliers should be identified on the monthly report by SBE certification number, name and the amount of actual payment made to each during the monthly period. **These reports are required regardless of whether or not SBE activity has occurred in the monthly reporting period.**
- 2.1.5.3. All such records must be retained for a period of 3 years following completion of the contract work and shall be available at reasonable times and places for inspection by authorized representatives of the Department.
- 2.1.6. **Compliance of Contractor.** To ensure that SBE requirements of this contract are complied with, the Department will monitor the Contractor's efforts to involve SBEs during the performance of this contract. This will be accomplished by a review of monthly reports submitted by the Contractor indicating his progress in achieving the SBE contract goal and by compliance reviews conducted by the Department.
- A Contractor's failure to comply with the requirements of this Special Provision shall constitute a material breach of this contract. In such a case, the Department reserves the right to employ remedies as the Department deems appropriate in the terms of the contract.
- 2.2. **Article B - No SBE Goal.**
- 2.2.1. **Policy.** It is the policy of the Department that SBEs shall have an opportunity to participate in the performance of contracts. Consequently, the requirements of the Department's Small Business Enterprise Program apply to this contract as specified in Section 2-5 of this Article.

- 2.2.2. **Contractor's Responsibilities.** If there is no SBE goal, the Contractor will offer SBEs an opportunity to participate in the performance of contracts and subcontracts.
- 2.2.3. **Prohibit Discrimination.** The Contractor and any subcontractor shall not discriminate on the basis of race, color, national origin, religion, age, disability or sex in the award and performance of contracts. These nondiscrimination requirements shall be incorporated into any subcontract and purchase order.
- 2.2.4. **Records and Reports.**
- 2.2.4.1. The Contractor shall submit reports on SBE (including HUB and DBE) payments. The reports are to be sent to the Area Engineer's office. These reports will be due annually by the 31st of August or at project completion, whichever comes first.
- These reports will be required until all SBE subcontracting or supply activity is completed. The "SBE Progress Report" is to be used for reporting. Upon completion of the contract and prior to receiving the final payment, the Contractor shall submit the "SBE Final Report" to the Office of Civil Rights and a copy to the Area Engineer. These forms may be obtained from the Office of Civil Rights and reproduced as necessary. The Department may verify the amounts being reported as paid to SBEs by requesting copies of invoices and cancelled checks paid to SBEs on a random basis.
- 2.2.4.2. SBE subcontractors and/or suppliers should be identified on the report by SBE Certification Number, name and the amount of actual payment made.
- 2.2.4.3. All such records must be retained for a period of 3 years following completion of the contract work and shall be available at reasonable times and places for inspection by authorized representatives of the Department.

Special Provision 000

Certificate of Interested Parties (Form 1295)



Submit a notarized Form 1295, "Certificate of Interested Parties," in the following instances:

- at Contract execution for Contracts awarded by the Commission;
- at Contract execution for Contracts awarded by the District Engineer or Chief Engineer with an award amount of \$1,000,000 or more; at any time an existing Contract awarded by the District Engineer or Chief Engineer increases in value to \$1,000,000 or more due to changes in the Contract; at any time there is an increase of \$1,000,000 or more to an existing Contract (change orders, extensions, and renewals); or
- at any time there is a change to the information in Form 1295, when the form was filed for an existing Contract.

Form 1295 and instructions on completing and filing the form are available on the Texas Ethics Commission website.

Special Provision 000

Important Notice to Contractors



For Dollar Amount of Original Contract		Dollar Amount of Daily Contract Administration Liquidated Damages per Working Day
From More Than	To and including	
0	1,000,000	618
1,000,000	3,000,000	832
3,000,000	5,000,000	940
5,000,000	15,000,000	1317
15,000,000	25,000,000	1718
25,000,000	50,000,000	2411
50,000,000	Over 50,000,000	4265

In addition to the amount shown in Table 1, the Liquidated Damages will be increased by the amount shown in Item 8 of the General Notes for Road User Cost (RUC), when applicable.

Special Provision 000

Important Notice to Contractors



As of January 5, 2023 utilities within the project limits have not been cleared. The Department anticipates clearance by the dates listed below. Unless otherwise stated, clearance of these obstructions will be performed by their owners. Estimated clearance dates are not anticipated to interfere with the Contractor's operations. In the event the clearance dates are not met, requests for additional compensation or time will be made in accordance with the Standard Specifications.

The Contractor is invited to review the mapped information of obstructions on file with the Engineer.

UTILITY INFORMATION					
Utility Owner	Description / Location	Estimated Clearance Date	Phase Impacted	Phase Start Date	Effect on Construction
City of Hereford Steve Bartels 806-363-7100 steve@go-herd.com	Underground Water Line Crossing STA 698+90–STA 699+30 Water Line E–crossing at Progressive	May 13, 2024	Segment 1, Phase 1	August 5, 2024	Conflicts with proposed roadway pavement. 3-mo. buffer.
City of Hereford Steve Bartels 806-363-7100 steve@go-herd.com	Underground Water Line Crossing STA 744+60–STA 745+35 Water line C-1 Crossing at Rd GD/Whittier	May 13, 2024	Segment 1, Phase 1	August 5, 2024	Conflicts with proposed roadway pavement. 3-mo. buffer.
City of Hereford Steve Bartels 806-363-7100 steve@go-herd.com	Underground Water Line Crossing STA 829+49–STA 829+81	May 13, 2024	Segment 3, Phase 1	September 4, 2024	Conflicts with proposed roadway pavement. 4-mo. buffer.
City of Hereford Steve Bartels 806-363-7100 steve@go-herd.com	Underground Water Line Crossing STA 825+50–STA 827+90	May 13, 2024	Segment 3, Phase 1	September 4, 2024	Conflicts with proposed roadway pavement. 4-mo. buffer.
City of Hereford Steve Bartels 806-363-7100 steve@go-herd.com	Underground Water Line Longitudinal STA 829+73 40' LT–STA 846+88 47' LT	May 13, 2024	Segment 3, Phase 1	September 4, 2024	Conflicts with proposed roadway pavement. 4-mo. buffer.
City of Hereford Steve Bartels 806-363-7100 steve@go-herd.com	Underground Water Line Longitudinal STA 744+50 50' RT–STA 747+00 50' RT	May 13, 2024	Segment 1, Phase 2	January 20, 2025	Conflicts with proposed drainage. 8-mo. buffer.
City of Hereford Steve Bartels 806-363-7100 steve@go-herd.com	Underground Water Line Longitudinal STA 697+85 42' RT–STA 699+10 42' RT	May 13, 2024	Segment 1, Phase 2	January 20, 2025	Conflicts with proposed drainage. 8-mo. buffer.
City of Hereford Steve Bartels 806-363-7100 steve@go-herd.com	Underground Water Line Longitudinal STA 699+95 42' RT–STA 720+40 51' RT	May 13, 2024	Segment 1, Phase 2	January 20, 2025	Conflicts with proposed roadway pavement. 8-mo. buffer.
City of Hereford Steve Bartels 806-363-7100 steve@go-herd.com	Underground Water Line Longitudinal STA 722+40 50' RT–STA 732+80 50' RT	May 13, 2024	Segment 1, Phase 2	January 20, 2025	Conflicts with proposed roadway pavement. 8-mo. buffer.
City of Hereford Steve Bartels 806-363-7100 steve@go-herd.com	Underground Water Line Longitudinal STA 735+50 50' RT–STA 744+20 52' RT	May 13, 2024	Segment 1, Phase 2	January 20, 2025	Conflicts with proposed roadway pavement. 8-mo. buffer.

UTILITY INFORMATION					
Utility Owner	Description / Location	Estimated Clearance Date	Phase Impacted	Phase Start Date	Effect on Construction
City of Hereford Steve Bartels 806-363-7100 steve@go-herd.com	Underground Sanitary Sewer Line Longitudinal STA 698+80 42' RT–STA 699+10 42' RT	May 13, 2024	Segment 1, Phase 2	January 20, 2025	Conflicts with proposed drainage. 8-mo. buffer.
City of Hereford Steve Bartels 806-363-7100 steve@go-herd.com	Underground Sanitary Sewer Line Longitudinal STA 720+70 51' RT–STA 722+15 51' RT	May 13, 2024	Segment 1, Phase 2	January 20, 2025	Conflicts with proposed roadway pavement. 8-mo. buffer.
City of Hereford Steve Bartels 806-363-7100 steve@go-herd.com	Underground Sanitary Sewer Line Longitudinal STA 745+03 43' RT–STA 747+20 84' RT	May 13, 2024	Segment 1, Phase 2	January 20, 2025	Conflicts with proposed sidewalk. 8-mo. buffer.
City of Hereford Steve Bartels 806-363-7100 steve@go-herd.com	Underground Water Line Longitudinal STA 830+00 46' RT–STA 838+40 50' RT	May 13, 2024	Segment 3, Phase 2	January 9, 2025	Conflicts with proposed roadway pavement. 8-mo. buffer.
City of Hereford Steve Bartels 806-363-7100 steve@go-herd.com	Underground Water Line Crossing STA 784+84–STA 784+87	September 15, 2024	Segment 2, Phase 1	August 19, 2025	Conflicts with proposed roadway pavement. 11-mo. buffer.
City of Hereford Steve Bartels 806-363-7100 steve@go-herd.com	Underground Water Line Crossing STA 784+46–STA 784+46	September 15, 2024	Segment 2, Phase 1	August 19, 2025	Conflicts with proposed roadway pavement. 11-mo. buffer.
City of Hereford Steve Bartels 806-363-7100 steve@go-herd.com	Underground Water Line Longitudinal STA 784+84 24' RT –STA 796+20 44' RT	September 15, 2024	Segment 2, Phase 1	August 19, 2025	Conflicts with proposed roadway pavement. 11-mo. buffer.
City of Hereford Steve Bartels 806-363-7100 steve@go-herd.com	Underground Water Line Crossing STA 797+79–STA 797+79	September 15, 2024	Segment 2, Phase 1	August 19, 2025	Conflicts with proposed roadway pavement. 11-mo. buffer.
City of Hereford Steve Bartels 806-363-7100 steve@go-herd.com	Underground Water Line Crossing STA 796+04–STA 796+04	September 15, 2024	Segment 2, Phase 1	August 19, 2025	Conflicts with proposed roadway pavement. 11-mo. buffer.
City of Hereford Steve Bartels 806-363-7100 steve@go-herd.com	Underground Water Line Crossing STA 802+90–STA 803+24	September 15, 2024	Segment 2, Phase 1	August 19, 2025	Conflicts with proposed roadway pavement. 11-mo. buffer.
City of Hereford Steve Bartels 806-363-7100 steve@go-herd.com	Underground Sanitary Sewer Line Longitudinal STA 771+79 2' LT–STA 816+15 18' RT	September 15, 2024	Segment 2, Phase 1	August 19, 2025	Conflicts with proposed roadway pavement. 11-mo. buffer.
City of Hereford Steve Bartels 806-363-7100 steve@go-herd.com	Underground Sanitary Sewer Line Longitudinal STA 811+40 23' LT–STA 820+00 32' LT	September 15, 2024	Segment 2, Phase 1	August 19, 2025	Conflicts with proposed roadway pavement. 11-mo. buffer.
City of Hereford Steve Bartels 806-363-7100 steve@go-herd.com	Underground Sanitary Sewer Line Crossing STA 816+80–STA 818+30	September 15, 2024	Segment 2, Phase 1	August 19, 2025	Conflicts with proposed roadway pavement. 11-mo. buffer.
City of Hereford Steve Bartels 806-363-7100 steve@go-herd.com	Underground Sanitary Sewer Line Crossing STA 816+48–STA 816+49	September 15, 2024	Segment 2, Phase 1	August 19, 2025	Conflicts with proposed drainage. 11-mo. buffer.
City of Hereford Steve Bartels 806-363-7100 steve@go-herd.com	Underground Water Line Longitudinal STA 818+50 6' RT–STA 821+79 74' RT	September 15, 2024	Segment 2, Phase 1	August 19, 2025	Conflicts with proposed roadway pavement. 11-mo. buffer.

UTILITY INFORMATION					
Utility Owner	Description / Location	Estimated Clearance Date	Phase Impacted	Phase Start Date	Effect on Construction
City of Hereford Steve Bartels 806-363-7100 steve@go-herd.com	Underground Water Line Longitudinal STA 803+24 18' LT–STA 820+00 30' LT	September 15, 2024	Segment 2, Phase 1	August 19, 2025	Conflicts with proposed roadway pavement. 11-mo. buffer.
City of Hereford Steve Bartels 806-363-7100 steve@go-herd.com	Underground Water Line Crossing STA 814+47–STA 814+50	September 15, 2024	Segment 2, Phase 1	August 19, 2025	Conflicts with proposed roadway pavement. 11-mo. buffer.
City of Hereford Steve Bartels 806-363-7100 steve@go-herd.com	Underground Water Line Longitudinal STA 772+20 40' RT–STA 773+10 40' RT	September 15, 2024	Segment 2, Phase 2	February 25, 2026	Conflicts with proposed roadway pavement. 17-mo. buffer.
City of Hereford Steve Bartels 806-363-7100 steve@go-herd.com	Underground Water Line Longitudinal STA 784+84 46' RT–STA 785+05 45' RT	September 15, 2024	Segment 2, Phase 2	February 25, 2026	Conflicts with proposed drainage. 17-mo. buffer.
City of Hereford Steve Bartels 806-363-7100 steve@go-herd.com	Underground Water Line Longitudinal STA 795+00 32' RT–STA 796+04 33' RT	September 15, 2024	Segment 2, Phase 2	February 25, 2026	Conflicts with proposed signal conduit. 17-mo. buffer.
City of Hereford Steve Bartels 806-363-7100 steve@go-herd.com	Underground Water Line Longitudinal STA 796+75 43' RT–STA 798+50 42' RT	September 15, 2024	Segment 2, Phase 2	February 25, 2026	Conflicts with proposed roadway pavement. 17-mo. buffer.
City of Hereford Steve Bartels 806-363-7100 steve@go-herd.com	Underground Water Line Longitudinal STA 799+25 42' RT–STA 799+90 42' RT	September 15, 2024	Segment 2, Phase 2	February 25, 2026	Conflicts with proposed roadway pavement. 17-mo. buffer.
City of Hereford Steve Bartels 806-363-7100 steve@go-herd.com	Underground Water Line Longitudinal STA 760+20 90' RT–STA 761+00 38' RT	September 15, 2024	Segment 2, Phase 2	February 25, 2026	Conflicts with proposed drainage. 17-mo. buffer.
City of Hereford Steve Bartels 806-363-7100 steve@go-herd.com	Underground Water Line Crossing STA 762+15–STA 763+10	September 15, 2024	Segment 2, Phase 2	February 25, 2026	Conflicts with proposed drainage. 17-mo. buffer.
City of Hereford Steve Bartels 806-363-7100 steve@go-herd.com	Underground Water Line Longitudinal STA 765+70 40' RT–STA 766+90 40' RT	September 15, 2024	Segment 2, Phase 2	February 25, 2026	Conflicts with proposed drainage. 17-mo. buffer.
City of Hereford Steve Bartels 806-363-7100 steve@go-herd.com	Underground Water Line Longitudinal STA 769+40 36' RT–STA 771+30 36' RT	September 15, 2024	Segment 2, Phase 2	February 25, 2026	Conflicts with proposed roadway pavement. 17-mo. buffer.
City of Hereford Steve Bartels 806-363-7100 steve@go-herd.com	Underground Water Line Longitudinal STA 776+90 52' RT–STA 778+90 52' RT	September 15, 2024	Segment 2, Phase 2	February 25, 2026	Conflicts with proposed drainage. 17-mo. buffer.
City of Hereford Steve Bartels 806-363-7100 steve@go-herd.com	Underground Water Line Longitudinal STA 773+20 40' RT–STA 774+40 40' RT	September 15, 2024	Segment 2, Phase 2	February 25, 2026	Conflicts with proposed drainage. 17-mo. buffer.

Special Provision 000

Notice of Contractor Performance Evaluations



1. GENERAL

In accordance with Texas Transportation Code §223.012, the Engineer will evaluate Contractor performance based on quality, safety, and timeliness of the project.

2. DEFINITIONS

- 2.1. **Project Recovery Plan (PRP)**—a formal, enforceable plan developed by the Contractor, in consultation with the District, that documents the cause of noted quality, safety, and timeliness issues and specifies how the Contractor proposes to correct project-specific performance deficiencies.

In accordance with Title 43, Texas Administrative Code (TAC), §9.23, the District will request a PRP if the Contractor's performance on a project is below the Department's acceptable standards and will monitor the Contractor's compliance with the established plan.

- 2.2. **Corrective Action Plan (CAP)**—a formal, enforceable plan developed by the Contractor, and proposed for adoption by the Construction or Maintenance Division, that documents the cause of noted quality, safety, and timeliness issues and specifies how the Contractor proposes to correct statewide performance deficiencies.

In accordance with 43 TAC §9.23, the Division will request a CAP if the average of the Contractor's statewide final evaluation scores falls below the Department's acceptable standards for the review period and will monitor the Contractor's compliance with the established plan.

3. CONTRACTOR EVALUATIONS

In accordance with Title 43, Texas Administrative Code (TAC) §9.23, the Engineer will schedule evaluations at the following intervals, at minimum:

- Interim evaluations—at or within 30 days after the anniversary of the notice to proceed, for Contracts extending beyond 1 yr., and
- Final evaluation—upon project closeout.

In case of a takeover agreement, neither the Surety nor its performing Contractor will be evaluated.

In addition to regularly scheduled evaluations, the Engineer may schedule an interim evaluation at any time to formally communicate issues with quality, safety, or timeliness. Upon request, work with the Engineer to develop a PRP to document expectations for correcting deficiencies.

Comply with the PRP as directed. Failure to comply with the PRP may result in additional remedial actions available to the Engineer under Item 5, "Control of the Work." Failure to meet a PRP to the Engineer's satisfaction may result in immediate referral to the Performance Review Committee for consideration of further action against the Contractor.

The Engineer will consider and document any events outside the Contractor's control that contributed to the failure to meet performance standards or comply with a PRP, including consideration of sufficient time.

Follow the escalation ladder if there is a disagreement regarding an evaluation or disposition of a PRP. The Contractor may submit additional documentation pertaining to the dispute. The District Engineer's decision

on a Contractor's evaluation score and recommendation of action required in a PRP or follow up for non-compliance is final.

4. DIVISION OVERSIGHT

Upon request of the Construction or Maintenance Division, develop and submit for Division approval a proposed CAP to document expectations for correcting deficiencies in the performance of projects statewide.

Comply with the CAP as directed. The CAP may be modified at any time up to completion or resolution after written approval of the premise of change from the Division. Failure to meet an adopted or revised adopted CAP to the Division's satisfaction within 120 days will result in immediate referral to the Performance Review Committee for consideration of further action against the Contractor.

The Division will consider and document any events outside the Contractor's control that contributed to the failure to meet performance standards or comply with a CAP, including consideration of sufficient time and associated costs as appropriate.

5. PERFORMANCE REVIEW COMMITTEE

The Performance Review Committee, in accordance with 43 TAC §9.24, will review at minimum all final evaluations, history of compliance with PRPs, any adopted CAPs including agreed modifications, any information about events outside a Contractor's control contributing to the Contractor's performance, and any documentation submitted by the Contractor and may recommend one or more of the following actions:

- take no action,
- reduce the Contractor's bidding capacity,
- prohibit the Contractor from bidding on one or more projects,
- immediately suspend the Contractor from bidding for a specified period of time, by reducing the Contractor's bidding capacity to zero, or
- prohibit the Contractor from being awarded a Contract on which they are the apparent low bidder.

The Deputy Executive Director will determine any further action against the Contractor.

6. APPEALS PROCESS

In accordance with 43 TAC §9.25, the Contractor may appeal remedial actions determined by the Deputy Executive Director.

Special Provision to Item 2

Instructions to Bidders



Item 2, "Instructions to Bidders" of the Standard Specifications is amended with respect to the clauses cited below. No other clauses or requirements of this Item are waived or changed.

Article 3., "Issuing Proposal Forms," is supplemented by the following:

The Electronic State Business Daily (ESBD), the Integrated Contractor Exchange (iCX) system, and the project proposal are the official sources of advertisement and bidding information for the State and Local Lettings. Bidders should bid the project using the information found therein, including any addenda. These sources take precedence over information from other sources, including TxDOT webpages, which are unofficial and intended for informational purposes only.

Special Provision to Item 2

Instructions to Bidders



Item 2, "Instructions to Bidders," of the **Standard Specifications** is amended with respect to the clauses cited below. No other clauses or requirements of this Item are waived or changed.

Section 2.8.2., "**Proposal Guaranty,**" third paragraph is replaced by the following.

It is the Bidder's responsibility to ensure the electronic bid bond is issued in the name or Department vendor identification numbers of the Bidder or Bidders.

Special Provision to Item 2

Instructions to Bidders



Item 2, “Instructions to Bidders,” of the Standard Specifications is amended with respect to the clauses cited below. No other clauses or requirements of this Item are waived or changed.

Article 2.3., “Issuing Proposal Forms,” is supplemented by the following:

- the Bidder or affiliate of the Bidder that was originally determined as the apparent low Bidder on a project but was deemed nonresponsive for failure to register or participate in the Department of Homeland Security’s (DHS) E-Verify system as specified in **Article 2.15., “Department of Homeland Security (DHS) E-Verify System,”** is prohibited from rebidding that specific project.

Article 2.7., “Nonresponsive Bid,” is supplemented by the following:

- the Bidder failed to participate in the Department of Homeland Security’s (DHS) as specified in Article 2.15., “Department of Homeland Security (DHS) E-Verify System.”

Article 2.15., “Department of Homeland Security (DHS) E-Verify System,” is added.

The Department will not award a Contract to a Contractor that is not registered in the DHS E-Verify system. Remain active in E-Verify throughout the life of the Contract. In addition, in accordance with paragraph six of **Article 8.2., “Subcontracting,”** include this requirement in all subcontracts and require that subcontractors remain active in E-Verify until their work is completed.

If the apparent low Bidder does not appear in the DHS E-Verify system before award, the Contractor must submit documentation showing that they are compliant within 5 calendar days after bid opening. A Contractor that fails to comply or respond within the deadline will be declared nonresponsive. The Bidder forfeiting the proposal guaranty will not be considered in future proposals for the same work unless there has been a substantial change in the scope of the work.

The Department may recommend that the Commission:

- reject all bids, or
- award the Contract to the new apparent low Bidder, if the Department is able to verify the Bidder’s participation in the DHS E-Verify system.

If the Department is unable to verify the new apparent low Bidder’s participation in the DHS E-Verify system:

- the new apparent low Bidder will not be deemed nonresponsive,
- the new apparent low Bidder’s guaranty will not be forfeited,
- the Department will reject all bids,
- the new apparent low Bidder will remain eligible to receive future proposals for the same project, and
- the proposal guaranty of the original low bidder will become the property of the State, not as a penalty, but as liquidated damages.

Special Provision to Item 3 Award and Execution Contract



Item 3, Award and Execution of Contract," of the Standard Specifications is amended with respect to the clauses cited below. No other clauses or requirements of this Item are waived or changed.

Section 4.3, "Insurance." The first sentence is voided and replaced by the following:

For construction and building Contracts, submit a certificate of insurance showing coverages in accordance with Contract requirements. For routine maintenance Contracts, refer to Article 8, "Beginning of Work."

Article 8, "Beginning of Work." The first sentence is supplemented by the following:

For a routine maintenance Contract, do not begin work until a certificate of insurance showing coverages in accordance with the Contract requirements is provided and accepted.

Special Provision to Item 3

Award and Execution of Contract



Item 3, "Award and Execution of Contract" of the Standard Specifications is amended with respect to the clauses cited below. No other clauses or requirements of this Item are waived or changed.

Section 4.3 "Insurance" is being amended by the following:

Table 2
Insurance Requirements

Type of Insurance	Amount of Coverage
Commercial General Liability Insurance	Not Less Than: \$600,000 each occurrence
Business Automobile Policy	Not Less Than: \$600,000 combined single limit
Workers' Compensation	Not Less Than: Statutory
All Risk Builder's Risk Insurance (For building-facilities contracts only)	100% of Contract Price

Special Provision to Item 5

Control of the Work



Item 5, "Control of the Work," of the Standard Specifications is amended with respect to the clauses cited below. No other clauses or requirements of this Item are waived or changed.

Article 5.1, "Authority of Engineer," is voided and replaced by the following.

The Engineer has the authority to observe, test, inspect, approve, and accept the work. The Engineer decides all questions about the quality and acceptability of materials, work performed, work progress, Contract interpretations, and acceptable Contract fulfillment. The Engineer has the authority to enforce and make effective these decisions.

The Engineer acts as a referee in all questions arising under the terms of the Contract. The Engineer's decisions will be final and binding.

The Engineer will pursue and document actions against the Contractor as warranted to address Contract performance issues. Contract remedies include, but are not limited to, the following:

- conducting interim performance evaluations requiring a Project Recovery Plan, in accordance with Title 43, Texas Administrative Code (TAC) §9.23,
- requiring the Contractor to remove and replace defective work, or reducing payment for defective work,
- removing an individual from the project,
- suspending the work without suspending working day charges,
- assessing standard liquidated damages to recover the Department's administrative costs, including additional project-specific liquidated damages when specified in the Contract in accordance with 43 TAC §9.22,
- withholding estimates,
- declaring the Contractor to be in default of the Contract, and
- in case of a Contractor's failure to meet a Project Recovery Plan, referring the issue directly to the Performance Review Committee for consideration of further action against the Contractor in accordance with 43 TAC §9.24.

The Engineer will consider and document any events outside the Contractor's control that contributed to the failure to meet performance standards, including consideration of sufficient time.

Follow the issue escalation ladder if there is disagreement regarding the application of Contract remedies.

Special Provision to Item 5

Control of the Work



Item 5, "Control of the Work" of the Standard Specifications is amended with respect to the clauses cited below. No other clauses or requirements of this Item are waived or changed.

Article 5.4, "Coordination of Plans, Specifications, and Special Provisions," the last sentence of the last paragraph is replaced by the following:

Failure to promptly notify the Engineer will constitute a waiver of all contract claims against the Department for misunderstandings or ambiguities that result from the errors, omissions, or discrepancies.

Special Provision to Item 6

Control of Materials



For this project, Item 6, "Control of Materials," of the Standard Specifications, is hereby amended with respect to the clauses cited below, and no other clauses or requirements of this Item are waived or changed hereby.

Article 4., "Sampling, Testing, and Inspection," is supplemented by the following:

Meet with the Engineer and choose either the Department or a Department-selected Commercial Lab (CL) for conducting the subset of project-level sampling and testing shown in Table 1, "Select Guide Schedule Sampling and Testing." Selection may be made on a test by test basis. CLs will meet the testing turnaround times shown (includes test time and time for travel/sampling and reporting) and in all cases issue test reports as soon as possible.

If the Contractor chooses a Department-selected CL for any Table 1 sampling and testing:

- notify the Engineer, District Lab, and the CL of project scheduling that may require CL testing;
- provide the Engineer, District Lab, and CL at least 24 hours' notice by phone and e-mail;
- reimburse the Department for CL Table 1 testing using the contract fee schedule for the CL (including mileage and travel/standby time) at the minimum guide schedule testing frequencies;
- reimburse the Department for CL Table 1 testing above the minimum guide schedule frequencies for retesting when minimum frequency testing results in failures to meet specification limits;
- agree with the Engineer and CL upon a policy regarding notification for testing services;
- give any cancellation notice to the Engineer, District Lab, and CL by phone and e-mail;
- reimburse the Department a \$150 cancellation fee to cover technician time and mileage charges for previously scheduled work cancelled without adequate notice, which resulted in mobilization of technician and/or equipment by the CL; and
- all CL charges will be reimbursed to the Department by a deduction from the Contractor's monthly pay estimate.

If the CL does not meet the Table 1 turnaround times, testing charge to the Contractor will be reduced by 50% for the first late day and an additional 5% for each succeeding late day.

Approved CL project testing above the minimum testing frequencies in the Guide Schedule of Sampling and Testing, and not as the result of failing tests, will be paid by the Department.

Other project-level Guide Schedule sampling and testing not shown on Table 1 will be the responsibility of the Department.

Table 1
Select Guide Schedule Sampling and Testing (Note 1)

TxDOT Test	Test Description	Turn-Around Time (Calendar days)
SOILS/BASE		
Tex-101-E	Preparation of Soil and Flexible Base Materials for Testing (included in other tests)	
Tex-104-E	Liquid Limit of Soils (included in 106-E)	
Tex-105-E	Plastic Limit of Soils (included in 106-E)	
Tex-106-E	Calculating the Plasticity Index of Soils	7
Tex-110-E	Particle Size Analysis of Soils	6
Tex-113-E	Moisture-Density Relationship of Base Materials	7
Tex-114-E	Moisture-Density Relationship of Subgrade and Embankment Soil	7
Tex-115-E	Field Method for In-Place Density of Soils and Base Materials	2
Tex-116-E	Ball Mill Method for the Disintegration of Flexible Base Material	5
Tex-117-E, Part II	Triaxial Compression Tests For Disturbed Soils and Base Materials (Part II)	6
Tex-113-E w/ Tex-117-E	Moisture-Density Relationship of Base Materials with Triaxial Compression Tests For Disturbed Soils and Base Materials (Part II)	10
Tex-140-E	Measuring Thickness of Pavement Layer	2
Tex-145-E	Determining Sulfate Content in Soils - Colorimetric Method	4
HOT MIX ASPHALT		
Tex-200-F	Sieve Analysis of Fine and Coarse Aggregate (dry, from ignition oven with known correction factors)	1 (Note 2)
Tex-203-F	Sand Equivalent Test	3
Tex-206-F, w/ Tex-207-F, Part I, w/ Tex-227-F	(Lab-Molded Density of Production Mixture – Texas Gyrotory) Method of Compacting Test Specimens of Bituminous Mixtures with Density of Compacted Bituminous Mixtures, Part I - Bulk Specific Gravity of Compacted Bituminous Mixtures, with Theoretical Maximum Specific Gravity of Bituminous Mixtures	1 (Note 2)
Tex-207-F, Part I &/or Part VI	(In-Place Air Voids of Roadway Cores) Density of Compacted Bituminous Mixtures, Part I- Bulk Specific Gravity of Compacted Bituminous Mixtures &/or Part VI - Bulk Specific Gravity of Compacted Bituminous Mixtures Using the Vacuum Method	1 (Note 2)
Tex-207-F, Part V	Density of Compacted Bituminous Mixtures, Part V- Determining Mat Segregation using a Density-Testing Gauge	3
Tex-207-F, Part VII	Density of Compacted Bituminous Mixtures, Part VII - Determining Longitudinal Joint Density using a Density-Testing Gauge	4
Tex-212-F	Moisture Content of Bituminous Mixtures	3
Tex-217-F	Deleterious Material and Decantation Test for Coarse Aggregate	4
Tex-221-F	Sampling Aggregate for Bituminous Mixtures, Surface Treatments, and LRA (included in other tests)	
Tex-222-F	Sampling Bituminous Mixtures (included in other tests)	
Tex-224-F	Determination of Flakiness Index	3
Tex-226-F	Indirect Tensile Strength Test (production mix)	4
Tex-235-F	Determining Draindown Characteristics in Bituminous Materials	3
Tex-236-F (Correction Factors)	Asphalt Content from Asphalt Paving Mixtures by the Ignition Method (Determining Correction Factors)	4
Tex-236-F	Asphalt Content from Asphalt Paving Mixtures by the Ignition Method (Production Mixture)	1 (Note 2)
Tex-241-F w/ Tex-207-F, Part I, w/ Tex-227-F	(Lab-Molded Density of Production Mixture – Superpave Gyrotory) Superpave Gyrotory Compacting of Specimens of Bituminous Mixtures (production mixture) with Density of Compacted Bituminous Mixtures, Part I- Part I - Bulk Specific Gravity of Compacted Bituminous Mixtures, with Theoretical Maximum Specific Gravity of Bituminous Mixtures	1 (Note 2)
Tex-242-F	Hamburg Wheel-Tracking Test (production mix, molded samples)	3
Tex-244-F	Thermal Profile of Hot Mix Asphalt	1
Tex-246-F	Permeability of Water Flow of Hot Mix Asphalt	3
Tex-280-F	Flat and Elongated Particles	3
Tex-530-C	Effect of Water on Bituminous Paving Mixtures (production mix)	4

AGGREGATES		
Tex-400-A	Sampling Flexible Base, Stone, Gravel, Sand, and Mineral Aggregates	3
Tex-410-A	Abrasion of Coarse Aggregate Using the Los Angeles Machine	5
Tex-411-A	Soundness of Aggregate by Use of Sodium Sulfate or Magnesium Sulfate	12
Tex-461-A	Degradation of Coarse Aggregate by Micro-Deval Abrasion	5
CHEMICAL		
Tex-612-J	Acid Insoluble Residue for Fine Aggregate	4
GENERAL		
HMA Production Specialist [TxAPA – Level 1-A] (\$/hr)		
HMA Roadway Specialist [TxAPA – Level 1-B] (\$/hr)		
Technician Travel/Standby Time (\$/hr)		
Per Diem (\$/day – meals and lodging)		
Mileage Rate (\$/mile from closest CL location)		
Note 1 – Turn-Around Time includes test time and time for travel/sampling and reporting. Note 2 – These tests require turn-around times meeting the governing specifications. Provide test results within the stated turn-around time. CL is allowed one additional day to provide the signed and sealed report.		

Special Provision to Item 6

Control of Materials



Item 6, "Control of Materials" of the Standard Specifications is amended with respect to the clauses cited below. No other clauses or requirements of this Item are waived or changed.

Article 6.10., "Hazardous Materials," is voided and replaced by the following:

Comply with the requirements of Article 7.12., "Responsibility for Hazardous Materials."

Notify the Engineer immediately when a visual observation or odor indicates that materials on sites owned or controlled by the Department may contain hazardous materials. Except as noted herein, the Department is responsible for testing, removing, and disposing of hazardous materials not introduced by the Contractor. The Engineer may suspend work wholly or in part during the testing, removing, or disposing of hazardous materials, except in the case where hazardous materials are introduced by the Contractor.

Use materials that are free of hazardous materials. Notify the Engineer immediately if materials are suspected to contain hazardous materials. If materials delivered to the project by the Contractor are suspected to contain hazardous materials, have an approved commercial laboratory test the materials for the presence of hazardous materials as approved. Remove, remediate, and dispose of any of these materials found to contain hazardous materials. The work required to comply with this section will be at the Contractor's expense if materials are found to contain hazardous materials. Working day charges will not be suspended and extensions of working days will not be granted for activities related to handling hazardous material introduced by the Contractor. If suspected materials are not found to contain hazardous materials, the Department will reimburse the Contractor for hazardous materials testing and will adjust working day charges if the Contractor can show that this work impacted the critical path.

10.1. Painted Steel Requirements. Coatings on existing steel contain hazardous materials unless otherwise shown on the plans. Remove paint and dispose of steel coated with paint containing hazardous materials in accordance with the following:

10.1.1. Removing Paint From Steel For contracts that are specifically for painting steel, Item 446, "Field Cleaning and Painting Steel" will be included as a pay item. Perform work in accordance with that item.

For projects where paint must be removed to allow for the dismantling of steel or to perform other work, the Department will provide for a separate contractor (third party) to remove paint containing hazardous materials prior to or during the Contract. Remove paint covering existing steel shown not to contain hazardous materials in accordance with Item 446, "Field Cleaning and Painting Steel."

10.1.2. Removal and Disposal of Painted Steel. For steel able to be dismantled by unbolting, paint removal will not be performed by the Department. The Department will remove paint, at locations shown on the plans or as agreed, for the Contractor's cutting and dismantling purposes. Utilize Department cleaned locations for dismantling when provided or provide own means of dismantling at other locations.

Painted steel to be retained by the Department will be shown on the plans. For painted steel that contains hazardous materials, dispose of the painted steel at a steel recycling or smelting facility unless otherwise shown on the plans. Maintain and make available to the Engineer invoices and other records obtained from the facility showing the received weight of the steel and the facility name. Dispose of steel that does not contain hazardous material coatings in accordance with federal, state and local regulations.

10.2. Asbestos Requirements. The plans will indicate locations or elements where asbestos containing materials (ACM) are known to be present. Where ACM is known to exist or where previously unknown ACM has been found, the Department will arrange for abatement by a separate contractor prior to or during the Contract. Notify the Engineer of proposed dates of demolition or removal of structural elements with ACM at least 60 days before beginning work to allow the Department sufficient time for abatement.

The Department of State Health Services (DSHS), Asbestos Programs Branch, is responsible for administering the requirements of the National Emissions Standards for Hazardous Air Pollutants, 40 CFR Part 61, Subpart M and the Texas Asbestos Health Protection Rules (TAHPR). Based on EPA guidance and regulatory background information, bridges are considered to be a regulated "facility" under NESHAP. Therefore, federal standards for demolition and renovation apply.

The Department is required to notify the DSHS at least 10 working days (by postmarked date) before initiating demolition or renovation of each structure or load bearing member shown on the plans. If the actual demolition or renovation date is changed or delayed, notify the Engineer in writing of the revised dates in sufficient time to allow for the Department's notification to DSHS to be postmarked at least 10 days in advance of the actual work.

Failure to provide the above information may require the temporary suspension of work under Article 8.4., "Temporary Suspension of Work or Working Day Charges," due to reasons under the control of the Contractor. The Department retains the right to determine the actual advance notice needed for the change in date to address post office business days and staff availability.

10.3. Lead Abatement. Provide traffic control as shown on the plans, and coordinate and cooperate with the third party and the Department for managing or removing hazardous materials. Work for the traffic control shown on the plans and coordination work will not be paid for directly but will be subsidiary to pertinent Items.

Special Provision to Item 7

Legal Relations and Responsibilities



Item 7, "Legal Relations and Responsibilities," of the Standard Specifications is amended with respect to the clauses cited below. No other clauses or requirements of this Item are waived or changed.

Section 7.7.2., "Texas Pollutant Discharge Elimination System (TPDES) Permits and Storm Water Pollution Prevention Plans (SWP3)," is voided and replaced by the following:

7.2. Texas Pollution Discharge Elimination System (TPDES) Permits and Storm Water Pollution Prevention Plans (SWP3).

7.2.1. Projects with less than one acre of soil disturbance including required associated project specific locations (PSL's) per TPDES GP TXR 150000.

No posting or filing will be required for soil disturbances within the right of way. Adhere to the requirements of the SWP3.

7.2.2. Projects with one acre but less than five acres of soil disturbance including required associated PSL's per TPDES GP TXR 150000.

The Department will be considered a primary operator for Operational Control Over Plans and Specifications as defined in TPDES GP TXR 150000 for construction activity in the right of way. The Department will post a small site notice along with other requirements as defined in TPDES GP TXR 150000 as the entity of having operational control over plans and specifications for work shown on the plans in the right of way.

The Contractor will be considered a Primary Operator for Day-to-Day Operational Control as defined in TPDES GP TXR 150000 for construction activity in the right of way. In addition to the Department's actions, the Contractor will post a small site notice along with other requirements as defined in TPDES GP TXR 150000 as the entity of having day-to-day operational control of the work shown on the plans in the right of way. This is in addition to the Contractor being responsible for TPDES GP TXR 150000 requirements for on- right of way and off- right of way PSL's. Adhere to all requirements of the SWP3 as shown on the plans. The Contractor will be responsible for Implement the SWP3 for the project site in accordance with the plans and specifications, TPDES General Permit TXR150000, and as directed.

7.2.3. Projects with 5 acres or more of soil disturbance including required associated PSL's per TPDES GP TXR 150000.

The Department will be considered a primary operator for Operational Control Over Plans and Specifications as defined in TPDES GP TXR 150000 for construction activities in the right of way. The Department will post a large site notice, file a notice of intent (NOI), notice of change (NOC), if applicable, and a notice of termination (NOT) along with other requirements per TPDES GP TXR 150000 as the entity having operational control over plans and specifications for work shown on the plans in the right of way.

The Contractor will be considered a primary operator for Day-to-Day Operational Control as defined in TPDES GP TXR 150000 for construction activities in the right of way. In addition to the Department's actions, the Contractor shall file a NOI, NOC, if applicable, and NOT and post a large site notice along with other requirements as the entity of having day-to-day operational control of the work shown on the plans in the right of way. This is in addition to the Contractor

being responsible for TPDES GP TXR 150000 requirements for on- right of way and off- right of way PSL's. Adhere to all requirements of the SWP3 as shown on the plans.

Special Provision to Item 7

Legal Relations and Responsibilities



Item 7, "Legal Relations and Responsibilities" of the Standard Specifications is amended with respect to the clauses cited below. No other clauses or requirements of this Item are waived or changed.

Section 19.1., Minimum Wage Requirements for Federally Funded Contracts. The second paragraph is voided and replaced by the following:

Submit electronic payroll records to the Engineer using the Department's payroll system.

Section 19.2., Minimum Wage Requirements for State Funded Contracts. The second paragraph is voided and replaced by the following:

Submit electronic payroll records to the Engineer using the Department's payroll system.

Special Provision to Item 7

Legal Relations and Responsibilities



Item 7, "Legal Relations and Responsibilities," of the Standard Specifications is amended with respect to the clauses cited below. No other clauses or requirements of this Item are waived or changed.

Section 7.2.4., "Public Safety and Convenience." The first paragraph is deleted and replaced by the following.

Ensure the safety and convenience of the public and property as provided in the Contract and as directed. Keep existing roadways open to traffic or construct and maintain detours and temporary structures for safe public travel. Manage construction to minimize disruption to traffic. Maintain the roadway in a good and passable condition, including proper drainage and provide for ingress and egress to adjacent property.

If the construction of the project requires the closing of a highway, as directed, coordinate the closure with the Engineer and work to ensure all lanes and ramps possible are available during peak traffic periods before, during, and after significant traffic generator events to avoid any adverse economic impact on the municipalities during:

- dates or events as shown on the plans, and
- other dates as directed.

Special Provision to Item 007

Legal Relations and Responsibilities



Item 7, “Legal Relations and Responsibilities,” of the Standard Specifications is amended with respect to the clauses cited below.

Section 2.6., “**Barricades, Signs, and Traffic Handling,**” the first paragraph is voided and replaced by the following:

- 2.6. Barricades, Signs, and Traffic Handling. Comply with the requirements of Item 502 “**Barricades, Signs, and Traffic Handling,**” and as directed. Provide traffic control devices that conform to the details shown on the plans, the TMUTCD, and the **Department’s** Compliant Work Zone Traffic Control Device List maintained by the Traffic Safety Division. When authorized or directed, provide additional signs or traffic control devices not required by the plans.

Section 2.6.1., “**Contractor Responsible Person and Alternative,**” is voided and replaced by the following:

- 2.6.1. Contractor Responsible Person and Alternative. Designate in writing, a **Contractor’s** Responsible Person (CRP) and an alternate to be the representative of the Contractor who is responsible for taking or directing corrective measures regarding the traffic control. The CRP or alternate must be accessible by phone 24 hr. per day and able to respond when notified. The CRP and alternate must comply with the requirements of Section 2.6.5., “**Training.**”

Section 2.6.2, “**Flaggers,**” the first paragraph is voided and replaced by the following:

- 2.6.2. Flaggers. Designate in writing, a flagger instructor who will serve as a flagging supervisor and is responsible for training and assuring that all flaggers are qualified to perform flagging duties. Certify to the Engineer that all flaggers will be trained and make available upon request a list of flaggers trained to perform flagging duties.

Section 2.6.5, “**Training,**” is voided and replaced by the following:

- 2.6.5. Training. Train workers involved with the traffic control using Department-approved training as shown on the “**Traffic Control Training**” Material Producer List.

Coordinate enrollment, pay associated fees, and successfully complete Department-approved training or Contractor-developed training. Training is valid for the period prescribed by the provider. Except for law enforcement personnel training, refresher training is required every 4 yr. from the date of completion unless otherwise specified by the course provider. The Engineer may require training at a frequency instead of the period prescribed based on the **Department’s** needs. Training and associated fees will not be measured or paid for directly but are considered subsidiary to pertinent Items.

Certify to the Engineer that workers involved in traffic control and other work zone personnel have been trained and make available upon request a copy of the certification of completion to the Engineer. Ensure the following is included in the certification of completion:

- name of provider and course title,
- name of participant,
- date of completion, and
- date of expiration.

Where Contractor-developed training or a Department-approved training course does not produce a certification, maintain a log of attendees. Make the log available upon request. Ensure the log is legible and includes the following:

- printed name and signature of participant,
- name and title of trainer, and
- date of training.

2.6.5.1. Contractor-developed Training. Develop and deliver Contractor-developed training meeting the minimum requirements established by the Department. The outline for this training must be submitted to the Engineer for approval at the preconstruction meeting. The CRP or designated alternate may deliver the training instead of the Department-approved training. The work performed and materials furnished to develop and deliver the training will not be measured or paid for directly but will be considered subsidiary to pertinent Items.

2.6.5.1.1. Flagger Training Minimum Requirements. A **Contractor's** certified flagging instructor is permitted to train other flaggers.

2.6.5.1.2. Optional Contractor-developed Training for Other Work Zone Personnel. For other work zone personnel, the Contractor may provide training meeting the curriculum shown below instead of Department-approved training.

Minimum curriculum for Contractor-provided training is as follows:

Contractor-developed training must provide information on the use of personnel protection equipment, occupational hazards and health risks, and other pertinent topics related to traffic management. The type and amount of training will depend on the job duties and responsibilities. Develop training applicable to the work being performed. Develop training to include the following topics.

- The Life You Save May Be Your Own (or other similar company safety motto).
- Purpose of the training.
 - **It's the Law.**
 - To make work zones safer for workers and motorist.
 - To understand what is needed for traffic control.
 - To save lives including your own.
- Personal and Co-Worker Safety.
 - High Visibility Safety Apparel. Discuss compliant requirements; inspect regularly for fading and reduced reflective properties; if night operations are required, discuss the additional and appropriate required apparel in addition to special night work risks; if moving operations are underway, discuss appropriate safety measures specific to the situation and traffic control plan.
 - Blind Areas. A blind area is the area around a vehicle or piece of construction equipment not **visible to the operators, either by line of sight or indirectly by mirrors. Discuss the "Circle of Safety"** around equipment and vehicles; use of spotters; maintain eye contact with equipment operators; and use of hand signals.
 - Runovers and Backovers. Remain alert at all times; keep a safe distance from traffic; avoid turning your back to traffic and if you must then use a spotter; and stay behind protective barriers, whenever possible. Note: It is not safe to sit on or lean against a concrete barrier, these barriers can deflect four plus feet when struck by a vehicle.
 - Look out for each other, warn co-workers.
 - Be courteous to motorists.
 - Do not run across active roadways.
 - Workers must obey traffic laws and drive courteously while operating vehicles in the work zones.
 - Workers must be made aware of company distracted driving policies.
- Night Time Operations. Focus should be placed on projects with a nighttime element.

- Traffic Control Training. Basics of Traffic Control.
 - Identify work zone traffic control supervisor and other appropriate persons to report issues to when they arise.
 - Emphasize that work zone traffic control devices must be in clean and in undamaged condition. If devices have been hit but not damaged, put back in their correct place and report to traffic control supervisor. If devices have been damaged, replace with new one and report to traffic control supervisor. If devices are dirty, faded or have missing or damaged reflective tape clean or replace and report to traffic control supervisor. Show examples of non-acceptable device conditions. Discuss various types of traffic control devices to be used and where spacing requirements can be found.
 - Channelizing Devices and Barricades with Slanted Stripes. Stripes are to slant in the direction you want traffic to stay or move to; demonstrate this with a device.
 - Traffic Queuing. Workers must be made aware of traffic queuing and the dangers created by it. Workers must be instructed to immediately notify the traffic control supervisor and other supervisory personnel if traffic is queuing beyond advance warning sign and devices or construction limits.
 - Signs. Signs must be straight and not leaning. Report problems to the traffic control supervisor or other as designated for immediate repair. Covered signs must be fully covered. If covers are damaged or out of place, report to traffic control supervisor or other as designated.

Special Provision to Item 7

Legal Relations and Responsibilities



Item 7, "Legal Relations and Responsibilities" of the Standard Specifications is amended with respect to the clauses cited below. No other clauses or requirements of this Item are waived or changed.

Article 7.20, "**Security Incidents,**" is added.

- 20.1. Reporting of Security Incidents. **Immediately notify the Department's [Cyber Security Operations Center \(CSOC\) via the Report Cybersecurity Incident Page](#) on www.txdot.gov,** of any potential cybersecurity incident or breach involving Department data. A breach of system security is the unauthorized acquisition of computerized data that compromises the security, confidentiality, or integrity of sensitive personal information maintained by a person, including data that is encrypted if the person accessing the data has the key required to decrypt the data.
- 20.2. Liability for costs incurred. The Department reserves the right to hold the Contractor liable for all costs incurred by the Department to resolve a security incident introduced by the Contractor, their Subcontractors, or their Suppliers.

Special Provision to Item 8 Prosecution and Progress



Item 8, "Prosecution and Progress" of the Standard Specification is amended with respect to the clauses cited below. No other clauses or requirements of this Item are waived or changed.

Article 8.2., "Subcontracting," is supplemented by the following paragraph, which is added as paragraph six to this article:

The Contractor certifies by signing the Contract that the Contractor will not enter into any subcontract with a subcontractor that is not registered in the Department of Homeland Security's (DHS) E-Verify system. Require that all subcontractors working on the project register and require that all subcontractors remain active in the DHS E-Verify system until their work is complete on the project.

Special Provision to Item 8 Prosecution and Progress



Item 8, "Prosecution and Progress" of the Standard Specifications is amended with respect to the clause cited below. No other clauses or requirements of this Item are waived or changed.

Article 8.7.2., "Wrongful Default," is revised and replaced by the following:

If it is determined after the Contractor is declared in default, that the Contractor was not in default, the rights and obligations of all parties will be the same as if termination had been issued for the convenience of the public as provided in Article 8.8 "Termination of Contract."

Special Provision to Item 8 Prosecution and Progress



Item 8, "Prosecution and Progress" of the Standard Specifications is amended with respect to the clauses cited below. No other clauses or requirements of this Item are waived or changed.

Article 3., "Computation of Contract Time for Completion." The second paragraph is voided and replaced by the following:

The development of the conceptual time determination is intended to establish the number of working days on the Contract. Upon request, the Engineer will provide the conceptual time determination schedule to the Contractor for informational purposes only. The schedule assumes generic resources, production rates, sequences of construction, and average weather conditions based on historic data. Schedule labor, equipment, procurement of materials, subcontractor work, and all other necessary means to prosecute the work within the number of working days specified by the Contract.

Special Provision to Item 8 Prosecution and Progress



Item 8, "Prosecution and Progress," of the **Standard Specifications** is amended with respect to the clauses cited below. No other clauses or requirements of this Item are waived or changed.

Article **8.1., "Prosecution of Work."** The article is voided and replaced by the following.

Begin work within 90 calendar days after the authorization date to begin work. Prosecute the work continuously to completion within the working days specified. Unless otherwise shown on the plans, work may be prosecuted in concurrent phases if no changes are required to the traffic control plan or if a revised traffic control plan is approved. Notify the Engineer at least 24 hr. before beginning work or before beginning any new operation. Do not start new operations to the detriment of work already begun. Minimize interference to traffic.

For Contracts with callout work and work orders, begin work in the right of way within the specified time and continuously prosecute the work until completion.

Special Provision to Item 009

Measurement and Payment



Item 009 "Measurement and Payment" of the Standard Specifications is amended with respect to the clauses cited below. No other clauses or requirements of this Item are waived or changed.

Article 9.5., "PROGRESS PAYMENTS" is supplemented with the following:

It is the Department's desire to pay a Contractor for work through the last working day of the month; however, the use of early cut-off dates for monthly estimates and MOH is a project management practice to manage workload at the Area Office level. Approval for using early cut-off dates is at the District's discretion. The earliest cut-off date for estimates is the 25th of the month.

Article 9.6., "PAYMENT FOR MATERIAL ON HAND (MOH)" first paragraph is amended as follows:

If payment for MOH is desired, request compensation for the invoice cost of acceptable nonperishable materials that have not been used in the work before the request, and that have been delivered to the work location or are in acceptable storage places. Nonperishable materials are those that do not have a shelf life or whose characteristics do not materially change when exposed to the elements. Include only materials that have been sampled, tested, approved, or certified, and are ready for incorporation into the work. Only materials which are completely constructed or fabricated on the Contractor's order for a specific Contract and are so marked and on which an approved test report has been issued are eligible. Payment for MOH may include the following types of items: concrete traffic barrier, precast concrete box culverts, concrete piling, reinforced concrete pipe, and illumination poles. Any repairs required after fabricated materials have been approved for storage will require approval of the Engineer before being made and will be made at the Contractor's expense. Include only those materials and products, when cumulated under an individual item or similar bid items, that have an invoice cost of at least \$1,000 in the request for MOH payment (e.g. For MOH eligibility, various sizes of conductor are considered similar bid items and may be cumulated to meet the threshold; for small roadside signs, the sign supports, mounting bolts, and the sign face is considered one bid item or similar bid items for more than one pay item for sign supports.) Requests for MOH are to be submitted at least two days before but not later than the estimate cutoff date unless otherwise agreed. If there is a need to request MOH after the established cut-off date, the district can make accommodation as the need arises. This needed accommodation is to be the exception, though, and not the rule.

Special Provision to Item 9

Measurement and Payment



Item 9, "Measurement and Payment" of the Standard Specifications is amended with respect to the clauses cited below. No other clauses or requirements of this Item are waived or changed.

Section **7.1.4.3., "Standby Equipment Costs,"** is voided and replaced by the following:

7.1.4.3. Standby Equipment Costs. Payment for standby equipment will be made in accordance with Section 9.7.1.4., "Equipment." The 15% markup will be paid when standby is associated with extra work but will not be paid when standby is associated with damages.

Section 7.1.4.3.1., "**Contractor-Owned Equipment,**" is voided and replaced by the following:

7.1.4.3.1. Contractor-Owned Equipment. For Contractor-owned equipment:

- Standby will be paid at 50% of the monthly Rental Rate Blue Book rate after the regional and age adjustment factors have been applied. Operating costs will not be allowed. Calculate the standby rate as follows.

$$\text{Standby rate} = (\text{FHWA hourly rate} - \text{operating costs}) \times 50\%$$

- If an hourly rate is needed, divide the monthly Rental Rate Blue Book rate by 176.
- No more than 8 hr. of standby will be paid during a 24-hr. day period, nor more than 40 hr. per week.
- Standby costs will not be allowed during periods when the equipment would have otherwise been idle.

Special Provision to Item 300 Asphalt, Oils, and Emulsions



Item 300, "Asphalt, Oils, and Emulsions" of the **Standard Specifications** is replaced by Special Specification [3096](#), "Asphalts, Oils, and Emulsions." All Item 300 Special Provisions are no longer available, beginning with the April 2022 letting.

Special Provision to Item 302

Aggregates for Surface Treatments



Item 302, "Aggregates for Seal Coats," of the Standard Specifications, is hereby amended with respect to the clauses cited below, and no other clauses or requirements of this Item are waived or changed hereby.

Section 2.1., "Aggregate." Tables 2 and 3 are voided and replaced by the following.

Table 2
Aggregate Gradation Requirements (Cumulative % Retained¹)

Sieve	Grade								
	1	2	3S ²	3		4S ²	4	5S ²	5
				Non-Lightweight	Lightweight				
1"	-	-	-	-	-	-	-	-	-
7/8"	0-2	0	-	-	-	-	-	-	-
3/4"	20-35	0-2	0	0	0	-	-	-	-
5/8"	85-100	20-40	0-5	0-5	0-2	0	0	-	-
1/2"	-	80-100	55-85	20-40	10-25	0-5	0-5	0	0
3/8"	95-100	95-100	95-100	80-100	60-80	60-85	20-40	0-5	0-5
1/4"	-	-	-	95-100	95-100	-	-	65-85	-
#4	-	-	-	-	-	95-100	95-100	95-100	50-80
#8	99-100	99-100	99-100	98-100	98-100	98-100	98-100	98-100	98-100

1. Round test results to the nearest whole number.
2. Single-size gradation.

Table 3
Aggregate Quality Requirements

Property	Test Method	Requirement ¹	
		Minimum	Maximum
SAC	AQMP	As shown on the plans	
Deleterious Material ² , %	Tex-217-F , Part I	-	2.0
Decantation, %	Tex-406-A	-	1.5
Flakiness Index, %	Tex-224-F	-	17
Gradation	Tex-200-F , Part I	Table 2 Requirements	
Los Angeles Abrasion, %	Tex-410-A	-	35
Magnesium Sulfate Soundness, 5 Cycle, %	Tex-411-A	-	25
Micro-Deval Abrasion, %	Tex-461-A	Note 3	
Coarse Aggregate Angularity ⁴ , 2 Crushed Faces, %	Tex-460-A , Part I	85	-
Additional Requirements for Lightweight Aggregate			
Dry Loose Unit Wt., lb./cu. ft.	Tex-404-A	35	60
Pressure Slaking, %	Tex-431-A	-	6.0
Freeze-Thaw Loss, %	Tex-432-A	-	10.0
Water Absorption, 24hr., %	Tex-433-A	-	12.0

1. Material requirements are listed below, unless otherwise shown on the plans.
2. Not required for lightweight aggregate.
3. Used to estimate the magnesium sulfate soundness loss in accordance with Section 2.1.1.
4. Only required for crushed gravel.

Section 2.1.1., “Micro-Deval Abrasion,” is added.

The Engineer will perform a minimum of one Micro-Deval abrasion test in accordance with [Tex-461-A](#) for each coarse aggregate source per project that has a Rated Source Soundness Magnesium (RSSM) loss value greater than 15 as listed in the BRSQC. The Engineer may waive all Micro-Deval testing based on a satisfactory test history of the same aggregate source.

The Engineer will estimate the magnesium sulfate soundness loss for each coarse aggregate source, when tested, using the following formula.

$$Mg_{est.} = (RSSM)(MD_{act.}/RSMD)$$

where:

$Mg_{est.}$ = magnesium sulfate soundness loss

$MD_{act.}$ = actual Micro-Deval percent loss

$RSMD$ = Rated Source Micro-Deval

When the estimated magnesium sulfate soundness loss is greater than the maximum magnesium sulfate soundness loss specified, the coarse aggregate source will not be allowed for use unless otherwise approved by the Engineer. The Engineer may require additional testing before granting approval.

Section 2.2., “Precoating.” The third paragraph is voided and replaced by the following.

The Engineer retains the right to remove precoat material from aggregate samples in accordance with [Tex-210-F](#), or as recommended by the Construction Division, and test the aggregate to verify compliance with Table 2 and Table 3 requirements. Gradation testing may be performed with precoat intact.

Section 2.3., “Sampling,” is added.

Personnel who conduct sampling and witnessing of sampling must be certified by the Department-approved certification program. Supply the Engineer with a list of certified personnel and copies of their current certificates before beginning construction and when personnel changes are made. At any time during the project, the Engineer may perform production tests as deemed necessary in accordance with Item 5, “Control of the Work.”

The Engineer will sample aggregate from stockpiles located at the production site, intermediate distribution site, or project location in accordance with [Tex-221-F](#), Section 3.2.3. The Engineer will split each sample into 2 equal portions in accordance with [Tex-200-F](#), Section 3.3, and label these portions “Engineer” and “Contractor” or “Supplier.” Witness the sampling and splitting, and take immediate possession of the samples labeled “Contractor” or “Supplier”.

Section 2.4., “Reporting and Responsibilities,” is added.

The Engineer will provide test results to the Contractor and Supplier within 10 working days from the date the stockpile was sampled for sources listed on the Department’s Bituminous Rated Source Quality Catalog (BRSQC), unless otherwise directed. The Engineer will provide test results for the LA Abrasion ([Tex-410-A](#)) and Magnesium Sulfate Soundness ([Tex-411-A](#)) tests within 30 calendar days for sources not listed on the BRSQC, or for sources not meeting the requirements of Section 2.1.1., “Micro-Deval Abrasion.” The Engineer will report to the other party within 24 hours when any test result does not meet the requirements listed in Table 2 or Table 3.

Special Provision to Item 316

Seal Coat



Item 316, "Seal Coat" of the Standard Specifications is amended with respect to the clauses cited below. No other clauses or requirements of this Item are waived or changed.

Section 4.8, "Asphalt Placement" is supplemented by the following:

4.8.5. Collect all samples in accordance with Tex-500-C, "Sampling Bituminous Materials, Pre-Molded Joint Fillers, and Joint Sealers" from the distributor and with witness by the Engineer.

At least once per project, collect split samples of each binder grade and source used. The Engineer will submit one split sample to MTD for testing and retain the other split sample.

In addition, collect one sample of each binder grade and source used on the project for each production day. The Engineer will retain these samples.

The Engineer will keep all retained samples for one yr., for hot-applied binders and cutback asphalts; or for two mo., for emulsified asphalts. The Engineer may submit retained samples to MTD for testing as necessary or as requested by MTD.

Special Provision to Item 340 Dense-Graded Hot-Mix (Small Quantity)



Item 340, "Dense-Graded Hot-Mix (Small Quantity)" of the Standard Specifications is replaced by Special Specification [3076](#), "Dense-Graded Hot-Mix **Asphalt**," Section 4.9.4., "Exempt Production." All Item 340 Special Provisions and bid codes are no longer available, beginning with the February 2022 letting.

Special Provision to Item 341 Dense-Graded Hot-Mix Asphalt



Item 341, "Dense-Graded Hot-Mix Asphalt" **of the Standard Specifications is** replaced by Special Specification [3076](#), "Dense-Graded Hot-Mix Asphalt." All Item 341 Special Provisions and bid codes are no longer available, beginning with the February 2020 letting.

Special Provision to Item 342

Permeable Friction Course (PFC)



Item 342, "**Permeable Friction Course (PFC)**" of the Standard Specifications is replaced by Special Specification [3079](#), "Permeable Friction Course." All Item 342 Special Provisions and bid codes are no longer available, beginning with the April 2022 letting.

Special Provision to Item 347 Thin Overlay Mixture (TOM)



Item 347, "Thin Overlay Mixture (TOM)" of the Standard Specifications is replaced by Special Specification [3081](#), "Thin Overlay Mixture (TOM)". All Item 347 Special Provisions and bid codes are no longer available, beginning with the April 2022 letting.

Special Provision to Item 348

Thin Bonded Friction Courses



Item 348, "Thin Bonded Friction Courses" of the Standard Specifications is replaced by Special Specification [3082](#), "Thin Bonded Friction Courses." All Item 348 Special Provisions and bid codes are no longer available, beginning with the April 2022 letting.

Special Provision to Item 360

Concrete Pavement



Item 360, "Concrete Pavement" of the Standard Specifications is amended with respect to the clauses cited below. No other clauses or requirements of this Item are waived or changed.

Section 360.2.1., "Materials," the third paragraph is voided and replaced by the following:

For continuously reinforced concrete pavements, use a coarse aggregate with a rated coefficient of thermal expansion of not more than 5.5×10^{-6} in./in./°F as listed in the Department's *Concrete Rated Source Quality Catalog*.

Section 360.4.8.3., "Surface Texture," the second paragraph is voided and replaced by the following:

A metal-tine texture finish is required unless otherwise shown on the plans. Provide transverse or longitudinal tining unless otherwise shown on the plans. Immediately following the carpet drag, apply a single coat of evaporation retardant, if needed, at the rate recommended by the manufacturer. Provide the metal-tine finish immediately after the concrete surface has set enough for consistent tining. Operate the metal-tine device to obtain grooves approximately 3/16 in. deep, with a minimum depth of 1/8 in., and approximately 1/12 in. wide. Do not overlap a previously tined area. Use manual methods to achieve similar results on ramps, small or irregular areas, and narrow width sections of pavements. Repair damage to the edge of the slab and joints immediately after texturing. Do not tine pavement that will be overlaid or that is scheduled for blanket diamond grinding or shot blasting.

Special Provision to Item 420

Concrete Substructure



Item 420, "Concrete Substructures" of the Standard Specifications is amended with respect to the clause cited below. No other clauses or requirements of this Item are waived or changed.

Article 420.6., "Payment." The first paragraph is replaced by the following:

The work performed and materials furnished in accordance with this Item and measured as provided under "Measurement" will be paid for at the unit price bid for the class of concrete and element identified and by the special designation when appropriate. This price is full compensation for furnishing, hauling, and mixing concrete materials; furnishing, bending, fabricating, splicing, welding and placing the required reinforcement; clips, blocks, metal spacers, ties, wire, or other materials used for fastening reinforcement in place; placing, finishing, and curing concrete; mass placement controls; applying ordinary surface finish; furnishing and placing drains, metal flashing strips, and expansion-joint material; excavation, subgrade preparation; and forms and falsework, equipment, labor, tools, and incidentals.

Special Provision to Item 421

Hydraulic Cement Concrete



Item 421, "Hydraulic Cement Concrete" of the Standard Specifications is amended with respect to the clauses cited below. No other clauses or requirements of this Item are waived or changed.

Article 421.2., **"Materials,"** the second sentence of the first paragraph is voided and replaced by the following.

Provide aggregates from sources listed in the Department's Concrete Rated Source Quality Catalog (CRSQC).

Article 421.2.2., Supplementary Cementing Materials (SCM), is voided and replaced with the following.

Supplementary Cementitious Materials (SCM).

- Coal Ash. Furnish sources of fly ash, , Modified fly ash (MFA), harvested coal ash, and Ground Bottom Ash (GBA) conforming to [DMS-4610](#), "Coal Ash."
- Slag Cement. Furnish Slag Cement in accordance with [DMS-4620](#), "Slag Cement."
- Silica Fume. Furnish silica fume in accordance with [DMS-4630](#), "Silica Fume."
- Natural Pozzolans. Furnish Natural Pozzolans in accordance with [DMS-4635](#), "Natural Pozzolans."

Article 421.3.1.3., **"Agitators and Truck and Stationary Mixers,"** the first paragraph is voided and replaced by the following.

Provide stationary and truck mixers capable of combining the ingredients of the concrete into a thoroughly mixed and uniform mass and capable of discharging the concrete so that the requirements of [Tex-472-A](#) are met.

Article 421.3.1.3., **"Agitators and Truck and Stationary Mixers,"** is supplemented with the following.

Truck mixers with automated water and chemical admixture measurement and slump and slump flow monitoring equipment meeting the requirement of ASTM C94 will be allowed. Provide data every 6 mo. substantiating the accuracy of slump, slump flow, temperature, water, and chemical admixture measurements. The slump measured by the automated system must be within 1 in. of the slump measured in accordance with [Tex-415-A](#). The concrete temperature measured by the automated system must be within 1°F of concrete temperature measured in accordance with [Tex-422-A](#). The Engineer will not use the automated measurements for acceptance.

Article 421.4.2., "Mix Design Proportioning," Table 8 is voided and replaced by the following.

Table 8
Concrete Classes

Class of Concrete	Design Strength, ¹ Min f'_c (psi)	Max w/cm Ratio	Coarse Aggregate Grades ^{2,3,4}	Cement Types	Mix Design Options	Exceptions to Mix Design Options	General Usage ⁵
A	3,000	0.60	1-4, 8	I, II, I/II, IL, IP, IS, IT, V	1, 2, 4, & 7	When the cementitious material content does not exceed 520 lb./cu. yd., any coal ash or natural pozzolan listed in the MPL may be used at a cement replacement of 20% to 50%.	Curb, gutter, curb & gutter, conc. retards, sidewalks, driveways, back-up walls, anchors, non-reinforced drilled shafts
B	2,000	0.60	2-7				Riprap, traffic signal controller foundations, small roadside signs, and anchors
C ⁶	3,600	0.45	1-6	I, II, I/II, IP, IL, IS, IT, V	1-8		Drilled shafts, bridge substructure, traffic rail, culverts except top slab of direct traffic culverts, headwalls, wing walls, inlets, manholes, traffic barrier
E	3,000	0.50	2-5	I, II, I/II, IL, IP, IS, IT, V	1-8	When the cementitious material content does not exceed 520 lb./cu. yd., any coal ash or natural pozzolan listed in the MPL may be used at a cement replacement of 20% to 50%.	Seal concrete
F ⁶	Note ⁷	0.45	2-5	I, II, I/II, IP, IL, IS, IT, V			Railroad structures: occasionally for bridge piers, columns, bents, post-tension members
H ⁶	Note ⁷	0.45	3-6	I, II, I/II, III, IP, IL, IS, IT, V	1-4, 8	<p>Mix design options 1-8 allowed for cast-in-place concrete and the following precast elements unless otherwise stated in the plans:</p> <ul style="list-style-type: none"> ■ Bridge Deck Panels, ■ Retaining Wall Systems, ■ Coping, ■ Sound Walls, ■ Wall Columns, ■ Traffic Rail, ■ Traffic Barrier, ■ Long/Arch Span Culverts, and ■ precast concrete products included in Item 462, "Concrete Box Culverts and Drains, Item 464, "Reinforced Concrete Pipe," and Item 465, "Junction Boxes, Manholes, and Inlets." <p>Do not use Type III cement in mass placement concrete. Up to 20% of blended cement may be replaced with listed SCMs when Option 4 is used for precast concrete. Options 6, & 7 allowed for cast-in-place Class H concrete.</p>	Precast concrete, post-tension members
S ⁶	4,000	0.45	2-5	I, II, I/II, IP, IL, IS, IT, V	1-8		Bridge slabs, top slabs of direct traffic culverts, approach slabs

Class of Concrete	Design Strength, ¹ Min f'_c (psi)	Max w/cm Ratio	Coarse Aggregate Grades ^{2,3,4}	Cement Types	Mix Design Options	Exceptions to Mix Design Options	General Usage ⁵
P	See Item 360, "Concrete Pavement."	0.50	2-3	I, II, I/II, IL, IP, IS, IT, V	1-8	When the cementitious material content does not exceed 520 lb./cu. yd., any coal ash or natural pozzolan listed in the MPL's may be used at a cement replacement of 20% to 50%.	Concrete pavement
CO ⁶	4,600	0.40	6		1-8		Bridge deck concrete overlay
LMC ⁶	4,000	0.40	6-8				Latex-modified concrete overlay
SS ⁶	3,600	0.45	4-6	I, II, I/II, IP, IL, IS, IT, V	1-8	Use a Min cementitious material content of 658 lb./cu. yd. of concrete. Limit the alkali loading to 4.0 lbs./cu. yd. or less when using Option 7.	Slurry displacement shafts, underwater drilled shafts
K ⁶	Note ⁷	0.40	Note ⁷	I, II, I/II, III, IP, IL, IS, IT, V	1-8		Note ⁷
HES	Note ⁷	0.45	Note ⁷	I, IL, II, I/II, III		Mix design options do not apply. 700 lb. of cementitious material per cubic yard limit does not apply.	Concrete pavement, concrete pavement repair
"X" (HPC) <small>6,8,9</small>	Note ¹⁰	0.45	Note ¹⁰	I, II, I/II, III, IP, IL, IS, IT, V	1-4, & 8	Max coal ash replacement for Option 3 may be increased to 50%. Up to 20% of a blended cement may be replaced with listed SCMs for Option 4. Do not use Option 8 for precast concrete.	
"X" (SRC) <small>6,8,9</small>	Note ¹⁰	0.45	Note ¹⁰	I/II, II, IP, IL (MS or HS), IS, IT (MS or HS), V	1-4, & 7	When using coal ash, only use coal ashes allowed for SRC as listed in the Coal Ash MPL. Type III-MS may be used where allowed. Type I, Type IL, and Type III cements may be used when natural pozzolans are used or when coal ashes allowed for SRC as listed in the Coal Ash MPL are used, and with a Max w/cm of 0.40. Up to 20% of blended cement may be replaced with listed SCMs when Option 4 is used for precast concrete. Use Option 7 for precast concrete where allowed.	

- Design strength must be attained within 56 days.
- Do not use Grade 1 coarse aggregate except in massive foundations with 4 in. Min clear spacing between reinforcing steel bars, unless otherwise permitted. Do not use Grade 1 aggregate in drilled shafts.
- Use Grade 8 aggregate in extruded curbs unless otherwise approved.
- Other grades of coarse aggregate maybe used in non-structural concrete classes when allowed by the Engineer.
- For information only.
- Structural concrete classes.
- As shown on the plans or specified.
- "X" denotes class of concrete shown on the plans or specified.
- (HPC): High Performance Concrete, (SRC): Sulfate Resistant Concrete.
- Same as class of concrete shown on the plans.

Article 421.4.2.2., **“Aggregates,”** is supplemented by the following.

Use the following equation to determine if the aggregate combination meets the sand equivalency requirement when blending fine aggregate or using an intermediate aggregate:

$$\frac{(SE_1 \times P_1) + (SE_2 \times P_2) + (SE_{ia} \times P_{ia})}{100} \geq 80\%$$

where:

SE_1 = sand equivalency (%) of fine aggregate 1

SE_2 = sand equivalency (%) of fine aggregate 2

SE_{ia} = sand equivalency (%) of intermediate aggregate passing the 3/8 in. sieve

P_1 = percent by weight of fine aggregate 1 of the fine aggregate blend

P_2 = percent by weight of fine aggregate 2 of the fine aggregate blend

P_{ia} = percent by weight of intermediate aggregate passing the 3/8 in. sieve

Article 421.4.2.3., **“Chemical Admixtures,”** the second paragraph is voided and replaced with the following.

Use a 30% calcium nitrite solution when a corrosion-inhibiting admixture is required. Dose the admixture at the rate of gallons of admixture per cubic yard of concrete shown on the plans. Use set retarding admixtures, as needed, to control setting time to ensure concrete containing corrosion inhibiting admixtures remain workable for the entire duration of the concrete placement. Perform setting time testing and slump loss testing during trial batch testing.

Article 421.4.2.5., **“Slump,”** the second paragraph is voided and not replaced. Table 9 is voided and replaced with below:

Table 9
Placement Slump Requirements

General Usage	Placement Slump Range, ^{1,2} in.
Walls (over 9 in. thick), caps, columns, piers	3 – 7
Bridge slabs, top slabs of direct traffic culverts, approach slabs, concrete overlays, latex-modified concrete for bridge deck overlays	3 – 6
Inlets, manholes, walls (less than 9 in. thick), bridge railing, culverts, concrete traffic barrier, concrete pavement (formed)	4 – 6
Precast concrete	4 – 9
Underwater concrete placements	6 – 8-1/2
Drilled shafts, slurry displaced and underwater drilled shafts	See Item 416, “Drilled Shaft Foundations.”
Curb, gutter, curb and gutter, concrete retards, sidewalk, driveways, seal concrete, anchors, riprap, small roadside sign foundations, concrete pavement repair, concrete repair	As approved

1. Max slump values may be increase above these values shown using chemical admixtures, provided the admixture treated concrete has the same or lower water-to-cementitious ratio and does not exhibit segregation or excessive bleeding. Request approval to increase slump limits in advance for proper evaluation by the Engineer.
2. For fiber reinforced concrete, perform slump before addition of fibers.

Article 421.4.2.6., **“Mix Design Options,”** is voided and replaced with the following.

Option 1. Replace cement with at least the minimum dosage listed in the MPL for the coal ash or natural pozzolan used in the mixture. Do not replace more than 50% of the cement. Conduct Option 8 testing as listed on the MPL.

Option 2. Replace 35% to 50% of the cement with slag cement.

Option 3. Replace 35% to 50% of the cement with a combination of coal ash, slag cement, natural pozzolan, or at least 3% silica fume; however, no more than 10% may be silica fume.

Option 4. Use Type IP, Type IS, or Type IT cement as allowed in Table 8 for each class of concrete. When replacing blended cements with additional SCM's, the replacement limits in Option 3 will apply to the final cementitious mixture. When using coal

ash or natural pozzolans not having a minimum dosage listed in the MPL in the final cementitious mixture, perform Option 8 testing.

Option 5. Option 5 is left intentionally blank.

Option 6. Use a lithium nitrate admixture at a minimum dosage determined by testing conducted in accordance with [Tex-471-A](#). Before use of the mix, provide an annual certified test report signed and sealed by a licensed professional engineer, from a laboratory listed on the MPL, certified by the Materials and Tests Division as being capable of testing according to [Tex-471-A](#).

Option 7. Ensure the total alkali contribution from the cement in the concrete does not exceed 3.5 lb. per cubic yard of concrete when using hydraulic cement not containing SCMs calculated as follows:

$$\text{lb. alkali per cu. yd.} = \frac{(\text{lb. cement per cu. yd.}) \times (\% \text{ Na}_2\text{O equivalent in cement})}{100}$$

In the above calculation, use the maximum cement alkali content reported on the cement mill certificate.

Option 8. Use Table 10 when deviating from Options 1–3 or when required by the Coal Ash MPL. Perform required testing annually and submit results to the Engineer. Laboratories performing ASTM C1260, ASTM C1567, and ASTM C1293 testing must be listed on the MPL. Before use of the mix, provide a certified test report signed and sealed by a licensed professional engineer demonstrating the proposed mixture in accordance with the requirements of Table 10.

Provide a certified test report signed and sealed by a licensed professional engineer, when HPC is required, and less than 20% of the cement is replaced with SCMs, demonstrating ASTM C1876 test results indicate the uniaxial resistivity of the concrete is greater than 15.6 k Ω -cm tested immediately after either of the following curing schedules:

- Moisture cure specimens 56 days at 73°F.
- Moisture cure specimens 7 days at 73°F followed by 21 days at 100°F.

Table 10
Option 8 Testing and Mix Design Requirements

Scenario	ASTM C1260 Result		Testing Requirements for Mix Design Materials or Prescriptive Mix Design Options
	Mix Design Fine Aggregate	Mix Design Coarse Aggregate	
A	> 0.10%	> 0.10%	Determine the dosage of SCMs needed to limit the 14-day expansion of each aggregate ¹ to 0.10% when tested individually in accordance with ASTM C1567.
B	≤ 0.10%	≤ 0.10%	Use the Min replacement listed in the Coal Ash MPL, or when Option 8 is listed on the MPL, use a Min of 40% coal ash with a Max CaO ² content of 25%, or use any ternary combination which replaces 35% to 50% of cement.
	≤ 0.10%	ASTM C1293 1 yr. Expansion ≤ 0.04%	Use a minimum of 20% of any coal ash; or Use any ternary combination which replaces 20% to 50% of cement.
C	≤ 0.10%	> 0.10%	Determine the dosage of SCMs needed to limit the 14-day expansion of coarse and intermediate ¹ aggregate to ≤0.10% when tested individually in accordance with ASTM C1567.
D	> 0.10%	≤ 0.10%	Use the Min replacement listed in the Coal Ash MPL, or when Option 8 is listed on the MPL, use a Min of 40% coal ash with a Max CaO ² content of 25%, or use any ternary combination which replaces 35% to 50% of cement.
	> 0.10%	ASTM C1293 1 yr. Expansion ≤ 0.04%	Determine the dosage of SCMs needed to limit the 14-day expansion of each fine aggregate to ≤0.10% when individually tested in accordance with ASTM C1567.

1. Intermediate size aggregates will fall under the requirements of mix design coarse aggregate.
2. Average the CaO content from the previous ten values as listed on the test certificate.

Article 421.4.2.7., **“Optimized Aggregate Gradation (OAG) Concrete,”** the first sentence of the first paragraph is voided and replaced by the following.

The gradations requirements in Table 4 and Table 6 do not apply when OAG concrete is specified or used by the Contractor unless otherwise shown on the plans.

The fineness modulus for fine aggregate listed in Table 5, does not apply when OAG concrete is used,

Article 421.4.6.2., **“Delivering Concrete,”** the third paragraph is supplemented by the following.

When truck mixers are equipped with automated water or chemical admixture measurement and slump or slump flow monitoring equipment, the addition of water or chemical admixtures during transit is allowed. Reports generated by this equipment must be submitted to the Engineer daily.

Article 421.4.6.2., **“Delivering Concrete,”** the fifth paragraph is voided and replaced with the following. Begin the discharge of concrete delivered in truck mixers within the times listed in Table 14. Concrete delivered after these times, and concrete that has not begun to discharge within these times will be rejected.

Article 421.4.8.3., **“Testing of Fresh Concrete,”** is voided and replaced with the following.

Testing Concrete. The Engineer, unless specified in other Items or shown on the plans, will test the fresh and hardened concrete in accordance with the following methods:

- Slump. [Tex-415-A](#);
- Air Content. [Tex-414-A](#) or [Tex-416-A](#);
- Temperature. [Tex-422-A](#);
- Making and Curing Strength Specimens. [Tex-447-A](#);
- Compressive Strength. [Tex-418-A](#);
- Flexural Strength. [Tex-448-A](#); and
- Maturity. [Tex-426-A](#).

Flexural strength and maturity specimens will not be made unless specified in other items or shown on the plans.

Concrete with slump less than minimum required after all addition of water withheld will be rejected, unless otherwise allowed by the Engineer. Concrete with slump exceeding maximum allowed may be used at the **Contractor's option. If used, Engineer will make, test, and evaluate strength specimens as specified in Article 421.5., "Acceptance of Concrete."** Acceptance of concrete not meeting air content or temperature requirements will be determined by Engineer. Fresh concrete exhibiting segregation and excessive bleeding will be rejected.

Article 421.4.8.3.1., "Job-Control Testing," is voided and not replaced.

Special Provision to Item 440

Reinforcement for Concrete



Item 440, "Reinforcement for Concrete," of the Standard Specifications is amended with respect to the clauses cited below. No other clauses or requirements of this Item are waived or changed.

Article 440.2., "Materials," is supplemented with the following.

- 2.7. **Welded Deformed Bar Mat Reinforcement.** Provide welded deformed bar mats in accordance with ASTM A184 except as otherwise noted in this Specification. Fabricate welded bar mats from deformed steel bars in accordance with ASTM A706 by securely connecting every intersection with a process of electrical resistance welding that employs the principle of fusion combined with pressure. The bars must be assembled by automatic machines or by other suitable mechanical means that will assure accurate spacing and alignment of all bars of the finished product.
- 2.14. **Zinc-Coated, Hot-Dip Galvanized Class I or Class II Steel Reinforcement.** Provide zinc-coated, hot-dip galvanized Class I or Class II steel reinforcement in accordance with ASTM A767, Grade 60 or Grade 75, when shown on the plans and as allowed.
- 2.15. **Continuously Hot-Dip Galvanized Reinforcement (CGR).** Provide CGR in accordance with ASTM A1094 steel reinforcement, Grade 60 or Grade 75, when shown on the plans and as allowed.

Section 440.2.1., "Approved Mills." The second paragraph is voided and not replaced.

Section 440.2.5., "Weldable Reinforcing Steel," is supplemented with the following.

All welding operations must be performed before hot-dip galvanizing.

Section 440.2.8., "Mechanical Couplers," is voided and replaced with the following.

Use couplers of the type specified in [DMS-4510](#), "Mechanical Couplers for Reinforcing Steel," Section 4510.6.1., "General Requirements," when mechanical splices in reinforcing steel bars are shown on the plans.

Furnish only couplers pre-qualified in accordance with [DMS-4510](#), "Mechanical Couplers for Reinforcing Steel." Ensure sleeve-wedge type couplers are not used on coated reinforcing. Sample mechanical couplers in accordance with [Tex-743-I](#) for testing before use on individual projects. Test the mechanical couplers for every project in which mechanical couplers are used in accordance with [Tex-744-I](#). Furnish couplers only at locations shown on the plans.

Furnish couplers for stainless reinforcing steel with the same alloy designation as the reinforcing steel.

Provide hot-dip or mechanically galvanized couplers when splicing galvanized reinforcing or CGR.

Section 440.2.11., "Low Carbon/Chromium Reinforcing Steel." The first sentence is voided and replaced by the following.

Provide deformed steel bars in accordance with ASTM A1035, Grade 100, Type CS, when low-carbon, chromium-reinforcing steel is required on the plans. Type CM will be permitted only if specified on the plans.

Section 440.3.1., "Bending," is supplemented with the following.

Do not bend hot-dip galvanized reinforcement. Only minor positioning adjustments are permitted.

Bending of CGR is permitted after galvanizing.

Section 440.3.5., "Placing." The following will be added to the fourth paragraph.

Use Class 1 or Class 1A supports with CGR. Provide epoxy- or plastic-coated tie wires and clips for use with epoxy-coated reinforcing steel.

Section 440.3.6.3., "Repairing Coating," is supplemented with the following:

Repair damaged galvanized surfaces in accordance with Section 445.3.5.2., "Repair Processes."

Special Provision to Item 450

Railing



Item 450, "Railing" of the Standard Specifications is amended with respect to the clauses cited below. No other clauses or requirements of this Item are waived or changed.

Section 450.3.1.2., "Fabrication," is supplemented with the following.

Fabrication plants that produce metal railing (steel and aluminum) must be approved in accordance with DMS-7395, "Metal Railing Fabrication Plant Qualification." This required approval does not include fabricators of chain link fence. The Materials and Tests Division maintains a MPL of approved fabrication plants of metal railing.

Permanently mark each metal railing post base plate, at a visible location when erected, with the fabrication plant's insignia or trademark. For fabricated rail panels, provide this permanent mark on one post base plate, per panel.

Special Provision to Item 462

Concrete Box Culverts and Drains



Item 462, "Concrete Box Culverts and Drains," of the Standard Specifications, is hereby amended with respect to the clauses cited below, and no other clauses or requirements of this Item are waived or changed hereby.

Section 2.1., "General." The last paragraph is voided and replaced with the following:

Furnish material for precast formed and machine-made box culverts in accordance with DMS-7305, "Fabrication and Qualification Procedure for Multi-Project Fabrication Plants of Precast Concrete Drainage Structures."

Sections 2.2.2., "Formed Precast," and 2.2.3., "Machine-Made Precast," are voided and replaced by the following.

2.2.2 **Precast.** Precast formed and machine –made box culvert fabrication plants must be approved in accordance with DMS-7305, "Fabrication and Qualification Procedure for Multi-Project Fabrication Plants of Precast Concrete Drainage Structures." The Construction Division maintains a list of approved precast box culvert fabrication plants on the Department's MPL. Fabricate precast boxes in accordance with DMS-7305, "Fabrication and Qualification Procedure for Multi-Project Fabrication Plants of Precast Concrete Drainage Structures."

Sections 2.3.2., "Formed Precast," and 2.3.3., "Machine-Made Precast," are voided and replaced by the following.

2.3.2 **Precast.** Make, cure, and test compressive test specimens for precast formed and machine –made box culverts in accordance with DMS-7305, "Fabrication and Qualification Procedure for Multi-Project Fabrication Plants of Precast Concrete Drainage Structures."

Section 2.5., "Marking," the first paragraph is voided and replaced with the following.

Marking. Clearly mark each precast unit with the following:

- Name or trademark of fabricator and plant location;
- ASTM designation and product designation (when applicable);
- Date of manufacture,
- Box size,
- Minimum and maximum fill heights,
- Designation "TX" for precast units fabricated per DMS-7305,
- Fabricator's designated approval stamp for each approved unit,
- Designation "SR" for boxes meeting sulfate-resistant concrete plan requirements (when applicable), and
- Precast drainage structures used for jacking and boring (when applicable).

Section 2.6., "Tolerances." The section is voided and replaced with the following.

Ensure precast sections meet the permissible variations listed in ASTM C1577.

Ensure that the sides of a section at each end do not vary from being perpendicular to the top and bottom by more than 1/2 in. when measured diagonally between opposite interior corners. Deviations from this tolerance will be acceptable if the sections can be fitted at the plant and the joint opening at any point does not exceed 1 in. Use match-marks for proper installation on sections that have been accepted in this manner.

Ensure wall and slab thicknesses are not less than shown on the plans except for occasional deficiencies not greater than 3/16 in. or 5%, whichever is greater. If proper jointing is not affected, thicknesses in excess of plan requirements are acceptable.

Section 2.7., “Defects and Repair.” The section is voided and replaced with the following:

Fine cracks on the surface of members that do not extend to the plane of the nearest reinforcement are acceptable unless the cracks are numerous and extensive. Repair cracks that extend into the plane of the reinforcing steel in accordance with the Department’s Concrete Repair Manual. The Engineer may accept boxes with repairs that are sound, properly finished, and cured in conformance with pertinent specifications. Discontinue further production of precast sections until corrections are made and proper curing is provided when fine cracks on the surface indicate poor curing practices.

Repair precast boxes in accordance with DMS-7305, “Fabrication and Qualification Procedure for Multi-Project Fabrication Plants of Precast Concrete Drainage Structures.”

Section 2.8., “Storage and Shipment.” This section is voided and replaced with the following:

- 2.8 **Storage and Shipment.** Store precast sections on a level surface. Do not place any load on the sections until design strength is reached and curing is complete. Store and ship precast boxes in accordance with DMS-7305, “Fabrication and Qualification Production for Multi-Project Fabrication Plants of Precast Concrete Drainage Structures.

Special Provision to Item 464

Reinforced Concrete Pipe



Item 464, "Reinforced Concrete Pipe," of the Standard Specifications, is hereby amended with respect to the clauses cited below, and no other clauses or requirements of this Item are waived or changed hereby.

Section 2.1., "Fabrication." The section is voided and replaced with the following.

Fabrication plants must be approved by the Materials and Tests Division in accordance with DMS-7305, "Fabrication and Qualification Procedure for Multi-Project Fabrication Plants of Precast Concrete Drainage Structures," before furnishing precast reinforced concrete pipe for Departmental projects. The Department's MPL has a list of approved reinforced concrete pipe plants.

Furnish material and fabricate reinforced concrete pipe in accordance with DMS-7305, "Fabrication and Qualification Procedure for Multi-Project Fabrication Plants of Precast Concrete Drainage Structures."

Section 2.3., "Marking." The first paragraph is voided and replaced with the following.

Furnish each section of reinforced concrete pipe marked with the following information specified in DMS-7305, "Fabrication and Qualification Procedure for Multi-Project Fabrication Plants of Precast Concrete Drainage Structures."

- Class or D-Load of pipe,
- ASTM designation,
- Date of manufacture,
- Pipe size,
- Name or trademark of fabricator and plant location,
- Designation "TX" for precast units fabricated per DMS-7305;
- Designated fabricator's approval stamp for each approved unit,
- Pipe to be used for jacking and boring (when applicable), and
- Designation "SR" for pipe meeting sulfate-resistant concrete plan requirements (when applicable).

Section 2.5., "Causes for Rejection." The section is voided and replaced with the following.

Individual sections of pipe may be rejected for any of the conditions stated in the Annex of DMS-7305, "Fabrication and Qualification Procedure for Multi-Project Fabrication Plants of Precast Concrete Drainage Structures."

Section 2.6., "Repairs." The section is voided and replaced with the following:

Make repairs, if necessary, as stated in the Annex of DMS-7305, "Fabrication and Qualification Procedure for Multi-Project Fabrication Plants of Precast Concrete Drainage Structures."

Special Provision to Item 465

Junction Boxes, Manholes, and Inlets



Item 465, "Junction Boxes, Manholes, and Inlets," of the Standard Specifications, is hereby amended with respect to the clauses cited below, and no other clauses or requirements of this Item are waived or changed hereby.

Section 2.1., "Concrete," The section is voided and replaced with the following.

Furnish concrete per DMS-7305 for formed and machine-made precast junction boxes, manholes, and inlets. Furnish Class C concrete for cast-in-place junction boxes, manholes, and inlets unless otherwise shown on the plans.

Section 3.1., "Precast Junction Boxes, Manholes, and Inlets," The section is voided and replaced with the following.

Construct formed and machine-made precast junction boxes, manholes, and inlets in accordance with DMS-7305, "Fabrication and Qualification Procedure for Multi-Project Fabrication Plants of Precast Concrete Drainage Structures" and the Contract Plans, except as otherwise noted in this Item.

Multi-project fabrication plants as defined in Item 424 "Precast Concrete Structural Members (Fabrication)," that produce junction boxes, manholes, and inlets will be approved by the Materials and Tests Division in accordance with DMS-7305, "Fabrication and Qualification Procedure for Multi-Project Fabrication Plants of Precast Concrete Drainage Structures." The Department's MPL has a list of approved multi-project fabrication plants.

Section 3.1.1., "Lifting Holes," The section is voided and not replaced.

Section 3.1.2., "Marking," The section is voided and replaced with the following.

Marking. Clearly mark each precast junction box, manhole, and inlet unit with the following information:

- name or trademark of fabricator and plant location;
- product designation;
- ASTM designation (if applicable);
- date of manufacture;
- designation "TX" for precast units fabricated per DMS-7305;
- designated fabricator's approval stamp for each approved unit; and
- designation "SR" for product meeting sulfate-resistant concrete plan requirements (when applicable).

Special Provision to Item 502

Barricades, Signs and Traffic Handling



Item 502, "Barricades, Signs and Traffic Handling" of the Standard Specifications, is hereby amended with respect to the clauses cited below, and no other clauses or requirements of this Item are waived or changed hereby.

Article 502.1., "Description," is supplemented by the following:

Temporary work-zone (TWZ) traffic control devices manufactured after December 31, 2019, must have been successfully tested to the crashworthiness requirements of the 2016 edition of the Manual for Assessing Safety Hardware (MASH). Such devices manufactured on or before this date and successfully tested to NCHRP Report 350 or the 2009 edition of MASH may continue to be used throughout their normal service lives. An exception to the manufacture date applies when, based on the **project's** date of letting, a category of MASH-2016 compliant TWZ traffic control devices are not approved, or are not self-certified after the December 31, 2019, date. In such case, devices that meet NCHRP-350 or MASH-2009 may be used regardless of the manufacture date.

Such TWZ traffic control devices include: portable sign supports, barricades, portable traffic barriers designated exclusively for use in temporary work zones, crash cushions designated exclusively for use in temporary work zones, longitudinal channelizers, truck and trailer mounted attenuators. Category I Devices (i.e., lightweight devices) such as cones, tubular markers and drums without lights or signs attached however, may be self-certified by the vendor or provider, with documentation provided to Department or as are shown on Department's Compliant Work Zone Traffic Control Device List.

Article 502.4., "Payment," is supplemented by the following:

Truck mounted attenuators and trailer attenuators will be paid for under Special Specification, "**Truck Mounted Attenuator (TMA)** and Trailer Attenuator (TA)." Portable Changeable Message Signs will be paid for under Special Specification, "**Portable Changeable Message Sign.**" Portable Traffic Signals will be paid for under Special Specification, "**Portable Traffic Signals.**"

Special Provision to Item 506

Temporary Erosion, Sedimentation, and Environmental Controls



Item 506, “Temporary Erosion, Sedimentation, and Environmental Controls,” of the Standard Specifications is amended with respect to the clauses cited below. No other clauses or requirements of this Item are waived or changed.

Article 506.1., “**Description.**” The second paragraph is voided and replaced by the following.

Contractor is considered primary operator to have day-to-day operational control as defined in TPDES GP TXR150000.

- 1.1. For projects with soil disturbance of less than 1 acre, no submittal to TCEQ will be required but Contractor will follow SWP3. For projects with soil disturbance of 1 acre to less than 5 acres a small site notice will be posted at the site. For projects with soil disturbance of 5 acres or more a Notice of Intent (NOI) is required and a large site notice posted at site. Postings will be in accordance with TPDES GP TXR150000. Postings not associated with project specific locations will be in same location as **Department’s postings.**
- 1.2. Notice of Intent (NOI). Submit a NOI, if applicable, with the TCEQ under the TPDES GP TXR150000 at least 7 days prior to commencement of construction activities at the project site. Provide a signed copy to the Engineer and any other MS4 operators at the time of submittal. The Department will submit their NOI prior to contractor submission and will provide a **copy for Contractor’s use in completing the Contractor’s NOI form.**
- 1.3. Notice of Change (NOC). Upon concurrence of the Engineer, submit a NOC, if applicable, to the TCEQ within 14 days of discovery of a change or revision to the NOI as required by the TPDES GP TXR150000. Provide a signed copy of the NOC to the Engineer and any other MS4 operators at the time of submittal.
- 1.4. Notice of Termination (NOT). Upon concurrence of the Engineer, submit a NOT, if applicable, to the TCEQ within 30 days of the **Engineer’s approval that 70% native background vegetative cover is met or equivalent permanent stabilization have** been employed in accordance with the TPDES GP TXR 150000. Provide a signed copy of the NOT to the Engineer and any other MS4 operators at the time of submittal.

Section 506.3.1, “Contractor Responsible Person Environmental (CRPE) Qualifications and Responsibilities,” is supplemented by the following:

- 3.1. Contractor Responsible Person Environmental (CRPE) Qualifications and Responsibilities. Provide and designate in writing at the preconstruction conference a CRPE and alternate CRPE who have overall responsibility for the storm water management program. The CRPE will implement stormwater and erosion control practices; will oversee and observe stormwater control measure monitoring and management; will monitor the project site daily and produce daily monitoring reports as long as there are BMPs in place or soil disturbing activities are evident to ensure compliance with the SWP3 and TPDES General Permit TXR150000. Daily monitor reports shall be maintained and made available upon request. During time suspensions when work is not occurring or on contract non-work days, daily inspections are not required unless a rain event has occurred. The CRPE will provide recommendations on how to improve the effectiveness of control measures. **Attend the Department’s preconstruction conference** for the project. Ensure training is completed as identified in Section 506.3.3., “**Training,**” by all applicable personnel before employees work on the project. Document and maintain and make available upon request, a list, signed by the CRPE, of all applicable Contractor and subcontractor employees who have **completed the training. Include the employee’s name, the training course name, and date the employee completed the training.**

Section **506.3.3., “Training,**” is supplemented by the following:

Training is provided by the Department at no cost to the Contractor and is valid for 3 yr. from the date of completion. The Engineer may require the following training at a frequency less than 3 yr. based on environmental needs:

- **“Environmental Management System: Awareness Training for the Contractor”** (English and Spanish) (Approximate running time 20 min.), and
- **“Storm Water: Environmental Requirements During Construction”** (English and Spanish) (Approximate running time 20 min.).

The Contractor responsible person environmental (CRPE), **alternate CRPE designated for emergencies, Contractor's** superintendent, Contractor, and subcontractor lead personnel involved in soil disturbing or SWP3 activities must enroll in and complete the training listed below and maintain and make available upon request the certificate of completion. Training is provided by a third party and is valid for 3 yr. from the date shown on the Certificate of Completion. Coordinate enrollment as prescribed by the Department and pay associated fees for the following training:

- **“Revegetation During Construction,”**
- **“Construction General Permit Compliance,”** and
- **“Construction Stage Gate Checklist (CSGC).”**

Training and associated fee will not be measured or paid for directly but are subsidiary to this Item.

Special Provision to Item 520

Weighing and Measuring Equipment



Item 520, "Weighing and Measuring Equipment" of the Standard Specifications is amended with respect to the clauses cited below. No other clauses or requirements of this Item are waived or changed.

Article 520.2., "Equipment." The third paragraph is voided and replaced by the following.

Calibrate truck scales using weights certified by the Texas Department of Agriculture (TDA) or an equivalent agency as approved. Provide a written calibration report from a scale mechanic for truck scale calibrations. Cease plant operations during the checking operation. Do not use inaccurate or inadequate scales. Bring performance errors as close to zero as practicable when adjusting equipment.

Article 520.2., "Equipment." The fourth paragraph is amended to include the following:

At the Contractors option, an electronic ticket delivery system (e-ticketing) may be used instead of printed tickets. The use of e-ticketing will require written approval of the Engineer. At a minimum, the approved system will:

- Provide electronic, real-time e-tickets meeting the requirements of the applicable bid items;
- Automatically generate e-tickets using software and hardware fully integrated with the automated scale system used to weigh the material, and be designed in such a way that data input cannot be altered by the Contractor or the Engineer;
- Provide the Engineer access to the e-ticketing data in real-time with a web-based or app-based system compatible with iOS;
- Provide offline capabilities to prevent data loss if power or connectivity is lost;
- Require both the Contractor and the Engineer to accept or reject the e-ticket and provide the ability to record the information required by the applicable bid items, as well as any comments. Record the time of the approval/rejection and include it in the summary spreadsheet described below. Provide each party the capability to edit their respective actions and any entered information;

The Contractor may discontinue use of the e-ticket system and provide printed tickets as needed to meet the requirements of the applicable bid items.

Special Provision to Item 540 Metal Beam Guard Fence



Item 540, "Metal Beam Guard Fence" of the Standard Specifications is amended with respect to the clauses cited below. No other clauses or requirements of this Item are waived or changed.

Article 540.4.7, "Measurement," is voided and replaced with the following:

Long Span System. Measurement will be by each long span system, complete in place. Each long span system will be from the first CRT to the last CRT in the system.

Special Provision to Item 666

Retroreflectorized Pavement Markings



Item 666, "Retroreflectorized Pavement Markings," of the Standard Specifications is amended with respect to the clauses cited below. No other clauses or requirements of this Item are waived or changed.

Section 2.3., "Glass Traffic Beads." The first paragraph is voided and replaced by the following:

Furnish drop-on glass beads in accordance with DMS-8290, "Glass Traffic Beads," or as approved. Furnish a double-drop of Type II and Type III drop-on glass beads for longitudinal pavement markings where each type bead is applied separately in equal portions (by weight), unless otherwise approved. Apply the Type III beads before applying the Type II beads. Furnish Type II beads for work zone pavement markings and transverse markings or symbols.

Section 4.3.1., "Type I Markings.," is supplemented by the following:

4.3.1.3. Spot Striping. Perform spot striping on a callout basis with a minimum callout quantity as shown on the plans.

Section 4.3.2., "Type II Markings.," is supplemented by the following:

4.3.2.1. Spot Striping. Perform spot striping on a callout basis with a minimum callout quantity as shown on the plans.

Section 4.4., "Retroreflectivity Requirements.," is voided and replaced by the following.

Type I markings for Contracts totaling more than 20,000 ft. of pavement markings must meet the following minimum retroreflectivity values for all longitudinal edgeline, centerline or no passing barrier-line, and lane line markings when measured any time after 3 days, but not later than 10 days after application.

- White markings: 250 millicandelas per square meter per lux (mcd/m²/lx)
- Yellow markings: 175 mcd/m²/lx

Retroreflectivity requirements for Type I markings are not required for Contracts with less than 20,000 ft. of pavement markings or Contracts with callout work, unless otherwise shown on the plans.

Section 4.5., "Retroreflectivity Measurements.," is voided and replaced by the following:

Use a mobile retroreflectometer to measure retroreflectivity for Contracts totaling more than 50,000 ft. of pavement markings, unless otherwise shown on the plans. For Contracts with less than 50,000 ft. of pavement markings, mobile or portable retroreflectometers may be used at the Contractor's discretion. Coordinate with and obtain authorization from the Engineer before starting any retroreflectivity data collection.

Section 4.5.1., "Mobile Retroreflectometer Measurements." The last paragraph is voided and replaced by the following.

Restripe again at the Contractor's expense with a minimum of 0.060 in. (60 mils) of Type I marking material if the average of these measurements falls below the minimum retroreflectivity requirements. Take measurements every 0.1 miles a minimum of 10 days after this third application within that mile segment for that series of markings. If the markings do not meet minimum retroreflectivity after this third application, the Engineer may require removal of all existing markings, a new application as initially specified, and a repeat of the application process until minimum retroreflectivity requirements are met.

Section 4.5.2., "Portable Retroreflector Measurements." The first and second paragraphs are voided and replaced by the following.

Provide portable measurement averages for every 1.0 mile unless otherwise specified or approved. Take a minimum of 20 measurements for each 1-mi. section of roadway for each series of markings (e.g., edgeline, center skip line, each line of a double line) and direction of traffic flow when using a portable reflectometer. Measure each line in both directions for centerlines on two-way roadways (i.e., measure both double solid lines in both directions and measure all center skip lines in both directions). The spacing between each measurement must be at least 100 ft. The Engineer may decrease the mileage frequency for measurements if the previous measurements provide satisfactory results. The Engineer may require the original number of measurements if concerns arise.

Restripe at the Contractor's expense with a minimum of 0.060 in. (60 mils) of Type I marking material if the averages of these measurements fail. Take a minimum of 10 more measurements after 10 days of this second application within that mile segment for that series of markings. Restripe again at the Contractor's expense with a minimum of 0.060 in. (60 mils) of Type I marking material if the average of these measurements falls below the minimum retroreflectivity requirements. If the markings do not meet minimum retroreflectivity after this third application, the Engineer may require removal of all existing markings, a new application as initially specified, and a repeat of the application process until minimum retroreflectivity requirements are met.

Section 4.6. "Performance Period." The first sentence is voided and replaced by the following:

All longitudinal markings must meet the minimum retroreflectivity requirements within the time frame specified. All markings must meet all other performance requirements of this specification for at least 30 calendar days after installation.

Article 6. "Payment." The first two paragraphs are voided and replaced by the following.

The work performed and materials furnished in accordance with this Item and measured as provided under "Measurement" will be paid for at the unit price bid for "Pavement Sealer" of the size specified; "Retroreflectorized Pavement Markings" of the type and color specified and the shape, width, size, and thickness (Type I markings only) specified, as applicable; "Retroreflectorized Pavement Markings with Retroreflective Requirements" of the types, colors, sizes, widths, and thicknesses specified; "Retroreflectorized Profile Pavement Markings" of the various types, colors, shapes, sizes, and widths specified; or "Reflectorized Pavement Marking (Call Out)" of the shape, width, size, and thickness (Type I markings only) specified, as applicable; or "Pavement Sealer (Call Out)" of the size specified.

This price is full compensation for materials, application of pavement markings, equipment, labor, tools, and incidentals.

Special Provision to Item 680 Highway Traffic Signals



Item 680, "Highway Traffic Signals" of the Standard Specifications is amended with respect to the clauses cited below. No other clauses or requirements of this Item are waived or changed.

Article 680.3.1.1.2,"Conduit," The fourth sentence of the first paragraph is voided and replaced by the following.

Seal the ends of each conduit with approved sealant, after all cables and conductors are installed.

Special Provision to Special Specification 3096

Asphalts, Oils, and Emulsions



Special Specification 3096, "Asphalts, Oils, and Emulsions," is amended with respect to the clause cited below. No other clause or requirements of this Item are waived or changed.

Section 3096.2.2., Table 3 Polymer-Modified Asphalt Cement has been voided and replaced by the following:

Table 3
Polymer-Modified Asphalt Cement

Property	Test Procedure	Polymer-Modified Viscosity Grade											
		AC-12-5TR		NT-HA ¹		AC-15P		AC-20XP		AC-10-2TR		AC-20-5TR	
		Min	Max	Min	Max	Min	Max	Min	Max	Min	Max	Min	Max
Polymer		TR		-		SBS		SBS		TR		TR	
Polymer content, % (solids basis)	Tex-533-C or Tex-553-C	5.0	-	-	-	3.0	-	-	-	2.0	-	5.0	-
Dynamic shear, G*/sin δ , 82°C, 10 rad/s, kPa	T 315	-	-	1.0	-	-	-	-	-	-	-	-	-
Dynamic shear, G*/sin δ , 64°C, 10 rad/s, kPa	T 315	-	-	-	-	-	-	1.0	-	-	-	1.0	-
Dynamic shear, G*/sin δ , 58°C, 10 rad/s, kPa	T 315	1.0	-	-	-	-	-	-	-	1.0	-	-	-
Viscosity													
140°F, poise	T 202	1,200	-	-	-	1,500	-	2,000	-	1,000	-	2,000	-
275°F, poise	T 202	-	-	-	-	-	8.0	-	-	-	8.0	-	10.0
275°F, Pa-s	T 316	-	-	-	4.0	-	-	-	-	-	-	-	-
Penetration, 77°F, 100 g, 5 sec.	T 49	110	150	-	25	100	150	75	115	95	130	75	115
Elastic recovery, 50°F, %	Tex-539-C	55				55	-	55	-	30	-	55	-
Polymer separation	Tex-540-C	None		-		None		None		None		None	
Flash point, C.O.C., °F	T 48	425		425		425	-	425	-	425	-	425	-
Tests on residue from RTFOT aging and pressure aging:	T 240 and R 28												
Creep stiffness	T 313												
S, -18°C, MPa		-	300	-	-	-	300	-	300	-	300	-	300
m-value, -18°C		0.300	-	-	-	0.300	-	0.300	-	0.300	-	0.300	-

1. This is a hot-applied TRAIL product.

Section 3096.2.5., Diluted Emulsions tables has been added.

Diluted Emulsions. Provide emulsified asphalt that is homogeneous, does not separate after thorough mixing, and meets the requirements for the specified type and grade in Tables 12A, and 12B, where the suffixes 50/50, 40/60, and 30/70 mean 50% emulsion diluted with 50% water; 40% emulsion diluted with 60% water, and 30% emulsion diluted with 70% water, respectively. For example, CSS-1H 40/60 means 40% CSS-1H diluted with 60% water and AE-P 30/70 means 30% AE-P diluted with 70% water.

Table 12A
Diluted CSS-1H

Property	Test Procedure	Type-Grade					
		Diluted Slow-Setting					
		CSS-1H 50/50		CSS-1H 40/60		CSS-1H 30/70	
		Min	Max	Min	Max	Min	Max
Viscosity, Saybolt Furol 77°F, sec.	T 72	Report Only		Report Only		Report Only	
Distillation test: Residue by distillation, % by wt. Oil distillate, % by volume of emulsion	T 59	30	–	24	–	18	–
		–	0.5	–	0.5	–	0.5
Tests on residue from distillation:							
Penetration, 77°F, 100 g, 5 sec.	T 49	40	110	40	110	40	110
Solubility, %	T 44	97.5	–	97.5	–	97.5	–
Ductility, 77°F, 5 cm/min., cm	T 51	80	–	80	–	80	–

Table 12B
Diluted AE-P

Property	Test Procedure	Type-Grade					
		Diluted Slow-Setting					
		AE-P 50/50		AE-P 40/60		AE-P 30/70	
		Min	Max	Min	Min	Max	Min
Viscosity, Saybolt Furol 122°F, sec.	T 72	Report Only		Report Only		Report Only	
Asphalt emulsion distillation to 500°F followed by Cutback asphalt distillation of residue to 680°F: Residue after both distillations, % by wt. Total oil distillate from both distillations, % by volume of emulsion	T 59 & T 78	20	–	16	–	12	–
		12.5	20	10.0	16	7.5	12
Tests on residue after all distillations:							
Solubility, %	T 44	97.5	–	97.5	–	97.5	–
Float test, 122°F, sec.	T 50	50	200	50	200	50	200

Special Provision to Special Specification 6185

Truck Mounted Attenuator (TMA) and Trailer Attenuator (TA)



Item 6185, "Truck Mounted Attenuator (TMA) and Trailer Attenuator (TA)" of the Standard Specifications, is hereby amended with respect to the clauses cited below, and no other clauses or requirements of this Item are waived or changed hereby.

Article 4. "Measurement", is voided and replaced by the following:

- 4.1. **Truck Mounted Attenuator/Trailer Attenuator (Stationary).** This Item will be measured by the day. TMA/TAs must be set up in a work area and operational before a calendar day can be considered measurable. A day will be measured for each TMA/TA set up and operational on the worksite.
- 4.2. **Truck Mounted Attenuator/Trailer Attenuator (Mobile Operation).** This Item will be measured by the hour or by the day. The time begins once the TMA/TA is ready for operation at the predetermined site and stops when notified by the Engineer. When measurement by the hour is specified, a minimum of 4 hr. will be paid each day for each operating TMA/TA used in a mobile operation. When measurement by the day is specified, a day will be measured for each TMA/TA set up and operational on the worksite.

Special Specification 3076

Dense-Graded Hot-Mix Asphalt



1. DESCRIPTION

Construct a hot-mix asphalt (HMA) pavement layer composed of a compacted, dense-graded mixture of aggregate and asphalt binder mixed hot in a mixing plant. Payment adjustments will apply to HMA placed under this specification unless the HMA is deemed exempt in accordance with Section 3076.4.9.4., "Exempt Production."

2. MATERIALS

Furnish uncontaminated materials of uniform quality that meet the requirements of the plans and specifications.

Notify the Engineer of all material sources and before changing any material source or formulation. The Engineer will verify that the specification requirements are met when the Contractor makes a source or formulation change, and may require a new laboratory mixture design, trial batch, or both. The Engineer may sample and test project materials at any time during the project to verify specification compliance in accordance with Item 6, "Control of Materials."

- 2.1. **Aggregate.** Furnish aggregates from sources that conform to the requirements shown in Table 1 and as specified in this Section. Aggregate requirements in this Section, including those shown in Table 1, may be modified or eliminated when shown on the plans. Additional aggregate requirements may be specified when shown on the plans. Provide aggregate stockpiles that meet the definitions in this Section for coarse, intermediate, or fine aggregate. Aggregate from reclaimed asphalt pavement (RAP) is not required to meet Table 1 requirements unless otherwise shown on the plans. Supply aggregates that meet the definitions in [Tex-100-E](#) for crushed gravel or crushed stone. The Engineer will designate the plant or the quarry as the sampling location. Provide samples from materials produced for the project. The Engineer will establish the Surface Aggregate Classification (SAC) and perform Los Angeles abrasion, magnesium sulfate soundness, and Micro-Deval tests. Perform all other aggregate quality tests listed in Table 1. Document all test results on the mixture design report. The Engineer may perform tests on independent or split samples to verify Contractor test results. Stockpile aggregates for each source and type separately. Determine aggregate gradations for mixture design and production testing based on the washed sieve analysis given in [Tex-200-F](#), Part II.

- 2.1.1. **Coarse Aggregate.** Coarse aggregate stockpiles must have no more than 20% material passing the No. 8 sieve. Aggregates from sources listed in the Department's *Bituminous Rated Source Quality Catalog* (BRSQC) are preapproved for use. Use only the rated values for hot-mix listed in the BRSQC. Rated values for surface treatment (ST) do not apply to coarse aggregate sources used in hot-mix asphalt.

For sources not listed on the Department's BRSQC:

- build an individual stockpile for each material;
- request the Department test the stockpile for specification compliance; and
- once approved, do not add material to the stockpile unless otherwise approved.

Provide aggregate from non-listed sources only when tested by the Engineer and approved before use. Allow 30 calendar days for the Engineer to sample, test, and report results for non-listed sources.

Provide coarse aggregate with at least the minimum SAC shown on the plans. SAC requirements only apply to aggregates used on the surface of travel lanes. SAC requirements apply to aggregates used on surfaces other than travel lanes when shown on the plans. The SAC for sources on the Department's *Aggregate Quality Monitoring Program (AQMP)* ([Tex-499-A](#)) is listed in the BRSQC.

- 2.1.1.1. **Blending Class A and Class B Aggregates.** Class B aggregate meeting all other requirements in Table 1 may be blended with a Class A aggregate to meet requirements for Class A materials, unless otherwise shown on the plans. Ensure that at least 50% by weight, or volume if required, of the material retained on the No. 4 sieve comes from the Class A aggregate source when blending Class A and B aggregates to meet a Class A requirement unless otherwise shown on the plans. Blend by volume if the bulk specific gravities of the Class A and B aggregates differ by more than 0.300. Coarse aggregate from RAP and Recycled Asphalt Shingles (RAS) will be considered as Class B aggregate for blending purposes.

The Engineer may perform tests at any time during production, when the Contractor blends Class A and B aggregates to meet a Class A requirement, to ensure that at least 50% by weight, or volume if required, of the material retained on the No. 4 sieve comes from the Class A aggregate source. The Engineer will use the Department's mix design template, when electing to verify conformance, to calculate the percent of Class A aggregate retained on the No. 4 sieve by inputting the bin percentages shown from readouts in the control room at the time of production and stockpile gradations measured at the time of production. The Engineer may determine the gradations based on either washed or dry sieve analysis from samples obtained from individual aggregate cold feed bins or aggregate stockpiles. The Engineer may perform spot checks using the gradations supplied by the Contractor on the mixture design report as an input for the template; however, a failing spot check will require confirmation with a stockpile gradation determined by the Engineer.

- 2.1.1.2. **Micro-Deval Abrasion.** The Engineer will perform a minimum of one Micro-Deval abrasion test in accordance with [Tex-461-A](#) for each coarse aggregate source used in the mixture design that has a Rated Source Soundness Magnesium (RSSM) loss value greater than 15 as listed in the BRSQC. The Engineer will perform testing before the start of production and may perform additional testing at any time during production. The Engineer may obtain the coarse aggregate samples from each coarse aggregate source or may require the Contractor to obtain the samples. The Engineer may waive all Micro-Deval testing based on a satisfactory test history of the same aggregate source.

The Engineer will estimate the magnesium sulfate soundness loss for each coarse aggregate source, when tested, using the following formula:

$$Mg_{est.} = (RSSM)(MD_{act.}/RSMD)$$

where:

$Mg_{est.}$ = magnesium sulfate soundness loss

$MD_{act.}$ = actual Micro-Deval percent loss

$RSMD$ = Rated Source Micro-Deval

When the estimated magnesium sulfate soundness loss is greater than the maximum magnesium sulfate soundness loss specified, the coarse aggregate source will not be allowed for use unless otherwise approved. The Engineer will consult the Soils and Aggregates Section of the Materials and Tests Division, and additional testing may be required before granting approval.

- 2.1.2. **Intermediate Aggregate.** Aggregates not meeting the definition of coarse or fine aggregate will be defined as intermediate aggregate. Supply intermediate aggregates, when used that are free from organic impurities. The Engineer may test the intermediate aggregate in accordance with [Tex-408-A](#) to verify the material is free from organic impurities. Supply intermediate aggregate from coarse aggregate sources, when used that meet the requirements shown in Table 1 unless otherwise approved.

Test the stockpile if 10% or more of the stockpile is retained on the No. 4 sieve, and verify that it meets the requirements in Table 1 for crushed face count ([Tex-460-A](#)) and flat and elongated particles ([Tex-280-F](#)).

2.1.3.

Fine Aggregate. Fine aggregates consist of manufactured sands, screenings, and field sands. Fine aggregate stockpiles must meet the gradation requirements in Table 2. Supply fine aggregates that are free from organic impurities. The Engineer may test the fine aggregate in accordance with [Tex-408-A](#) to verify the material is free from organic impurities. Unless otherwise shown on the plans, up to 10% of the total aggregate may be field sand or other uncrushed fine aggregate. Use fine aggregate, with the exception of field sand, from coarse aggregate sources that meet the requirements shown in Table 1 unless otherwise approved.

Test the stockpile if 10% or more of the stockpile is retained on the No. 4 sieve and verify that it meets the requirements in Table 1 for crushed face count ([Tex-460-A](#)) and flat and elongated particles ([Tex-280-F](#)).

Table 1
Aggregate Quality Requirements

Property	Test Method	Requirement
Coarse Aggregate		
SAC	Tex-499-A (AQMP)	As shown on the plans
Deleterious material, %, Max	Tex-217-F , Part I	1.5
Decantation, %, Max	Tex-217-F , Part II	1.5
Micro-Deval abrasion, %	Tex-461-A	Note 1
Los Angeles abrasion, %, Max	Tex-410-A	40
Magnesium sulfate soundness, 5 cycles, %, Max	Tex-411-A	30
Crushed face count, ² %, Min	Tex-460-A , Part I	85
Flat and elongated particles @ 5:1, %, Max	Tex-280-F	10
Fine Aggregate		
Linear shrinkage, %, Max	Tex-107-E	3
Sand equivalent, %, Min	Tex-203-F	45

- Used to estimate the magnesium sulfate soundness loss in accordance with Section 3076.2.1.1.2., "Micro-Deval Abrasion."
- Only applies to crushed gravel.

Table 2
Gradation Requirements for Fine Aggregate

Sieve Size	% Passing by Weight or Volume
3/8"	100
#8	70–100
#200	0–30

2.2.

Mineral Filler. Mineral filler consists of finely divided mineral matter such as agricultural lime, crusher fines, hydrated lime, or fly ash. Mineral filler is allowed unless otherwise shown on the plans. Use no more than 2% hydrated lime or fly ash unless otherwise shown on the plans. Use no more than 1% hydrated lime if a substitute binder is used unless otherwise shown on the plans or allowed. Test all mineral fillers except hydrated lime and fly ash in accordance with [Tex-107-E](#) to ensure specification compliance. The plans may require or disallow specific mineral fillers. Provide mineral filler, when used, that:

- is sufficiently dry, free-flowing, and free from clumps and foreign matter as determined by the Engineer;
- does not exceed 3% linear shrinkage when tested in accordance with [Tex-107-E](#); and
- meets the gradation requirements in Table 3, unless otherwise shown on the plans.

Table 3
Gradation Requirements for Mineral Filler

Sieve Size	% Passing by Weight or Volume
#8	100
#200	55–100

2.3.

Baghouse Fines. Fines collected by the baghouse or other dust-collecting equipment may be reintroduced into the mixing drum.

2.4.

Asphalt Binder. Furnish the type and grade of performance-graded (PG) asphalt specified on the plans.

- 2.5. **Tack Coat.** Furnish CSS-1H, SS-1H, or a PG binder with a minimum high-temperature grade of PG 58 for tack coat binder in accordance with Item 300, "Asphalts, Oils, and Emulsions." Specialized tack coat materials listed on the Department's MPL are allowed or required when shown on the plans. Do not dilute emulsified asphalts at the terminal, in the field, or at any other location before use.
- 2.6. **Additives.** Use the type and rate of additive specified when shown on the plans. Additives that facilitate mixing, compaction, or improve the quality of the mixture are allowed when approved. Provide the Engineer with documentation such as the bill of lading showing the quantity of additives used in the project unless otherwise directed.
- 2.6.1. **Lime and Liquid Antistripping Agent.** When lime or a liquid antistripping agent is used, add in accordance with Item 301, "Asphalt Antistripping Agents." Do not add lime directly into the mixing drum of any plant where lime is removed through the exhaust stream unless the plant has a baghouse or dust collection system that reintroduces the lime into the drum.
- 2.6.2. **Warm Mix Asphalt (WMA).** Warm Mix Asphalt (WMA) is defined as HMA that is produced within a target temperature discharge range of 215°F and 275°F using approved WMA additives or processes from the Department's MPL.
- WMA is allowed for use on all projects and is required when shown on the plans. When WMA is required, the maximum placement or target discharge temperature for WMA will be set at a value below 275°F.
- Department-approved WMA additives or processes may be used to facilitate mixing and compaction of HMA produced at target discharge temperatures above 275°F; however, such mixtures will not be defined as WMA.
- 2.6.3. **Compaction Aid.** Compaction Aid is defined as a chemical warm mix additive that is used to produce an asphalt mixture at a discharge temperature greater than 275°F.
- Compaction Aid is allowed for use on all projects and is required when shown on the plans.
- 2.7. **Recycled Materials.** Use of RAP and RAS is permitted unless otherwise shown on the plans. Use of RAS is restricted to only intermediate and base mixes unless otherwise shown on the plans. Do not exceed the maximum allowable percentages of RAP and RAS shown in Table 4. The allowable percentages shown in Table 4 may be decreased or increased when shown on the plans. Determine the asphalt binder content and gradation of the RAP and RAS stockpiles for mixture design purposes in accordance with [Tex-236-F](#), Part I. The Engineer may verify the asphalt binder content of the stockpiles at any time during production. Perform other tests on RAP and RAS when shown on the plans. Asphalt binder from RAP and RAS is designated as recycled asphalt binder. Calculate and ensure that the ratio of the recycled asphalt binder to total binder does not exceed the percentages shown in Table 5 during mixture design and HMA production when RAP or RAS is used. Use a separate cold feed bin for each stockpile of RAP and RAS during HMA production.
- Surface, intermediate, and base mixes referenced in Tables 4 and 5 are defined as follows:
- **Surface.** The final HMA lift placed at the top of the pavement structure or placed directly below mixtures produced in accordance with Items 316, 342, 347, or 348;
 - **Intermediate.** Mixtures placed below an HMA surface mix and less than or equal to 8.0 in. from the riding surface; and
 - **Base.** Mixtures placed greater than 8.0 in. from the riding surface. Unless otherwise shown on the plans, mixtures used for bond breaker are defined as base mixtures.
- 2.7.1. **RAP.** RAP is salvaged, milled, pulverized, broken, or crushed asphalt pavement. Fractionated RAP is defined as a stockpile that contains RAP material with a minimum of 95.0% passing the 3/8-in. or 1/2-in. sieve, before burning in the ignition oven, unless otherwise approved. The Engineer may allow the Contractor to use an alternate to the 3/8-in. or 1/2-in. screen to fractionate the RAP.

Use of Contractor-owned RAP including HMA plant waste is permitted unless otherwise shown on the plans. Department-owned RAP stockpiles are available for the Contractor's use when the stockpile locations are shown on the plans. If Department-owned RAP is available for the Contractor's use, the Contractor may use Contractor-owned fractionated RAP and replace it with an equal quantity of Department-owned RAP. Department-owned RAP generated through required work on the Contract is available for the Contractor's use when shown on the plans. Perform any necessary tests to ensure Contractor- or Department-owned RAP is appropriate for use. The Department will not perform any tests or assume any liability for the quality of the Department-owned RAP unless otherwise shown on the plans. The Contractor will retain ownership of RAP generated on the project when shown on the plans.

Do not use Department- or Contractor-owned RAP contaminated with dirt or other objectionable materials. Do not use Department- or Contractor-owned RAP if the decantation value exceeds 5% and the plasticity index is greater than 8. Test the stockpiled RAP for decantation in accordance with [Tex-406-A](#), Part I. Determine the plasticity index in accordance with [Tex-106-E](#) if the decantation value exceeds 5%. The decantation and plasticity index requirements do not apply to RAP samples with asphalt removed by extraction or ignition.

Do not intermingle Contractor-owned RAP stockpiles with Department-owned RAP stockpiles. Remove unused Contractor-owned RAP material from the project site upon completion of the project. Return unused Department-owned RAP to the designated stockpile location.

Table 4
Maximum Allowable Amounts of RAP¹

Maximum Allowable Fractionated RAP (%)		
Surface	Intermediate	Base
15.0	25.0	30.0

1. Must also meet the recycled binder to total binder ratio shown in Table 5.

2.7.2.

RAS. Use of post-manufactured RAS or post-consumer RAS (tear-offs) is not permitted in surface mixtures unless otherwise shown on the plans. RAS may be used in intermediate and base mixtures unless otherwise shown on the plans. Up to 3% RAS may be used separately or as a replacement for fractionated RAP in accordance with Table 4 and Table 5. RAS is defined as processed asphalt shingle material from manufacturing of asphalt roofing shingles or from re-roofing residential structures. Post-manufactured RAS is processed manufacturer's shingle scrap by-product. Post-consumer RAS is processed shingle scrap removed from residential structures. Comply with all regulatory requirements stipulated for RAS by the TCEQ. RAS may be used separately or in conjunction with RAP.

Process the RAS by ambient grinding or granulating such that 100% of the particles pass the 3/8 in. sieve when tested in accordance with [Tex-200-F](#), Part I. Perform a sieve analysis on processed RAS material before extraction (or ignition) of the asphalt binder.

Add sand meeting the requirements of Table 1 and Table 2 or fine RAP to RAS stockpiles if needed to keep the processed material workable. Any stockpile that contains RAS will be considered a RAS stockpile and be limited to no more than 3.0% of the HMA mixture in accordance with Table 4.

Certify compliance of the RAS with [DMS-11000](#), "Evaluating and Using Nonhazardous Recyclable Materials Guidelines." Treat RAS as an established nonhazardous recyclable material if it has not come into contact with any hazardous materials. Use RAS from shingle sources on the Department's MPL. Remove substantially all materials before use that are not part of the shingle, such as wood, paper, metal, plastic, and felt paper. Determine the deleterious content of RAS material for mixture design purposes in accordance with [Tex-217-F](#), Part III. Do not use RAS if deleterious materials are more than 0.5% of the stockpiled RAS unless otherwise approved. Submit a sample for approval before submitting the mixture design. The Department will perform the testing for deleterious material of RAS to determine specification compliance.

2.8.

Substitute Binders. Unless otherwise shown on the plans, the Contractor may use a substitute PG binder listed in Table 5 instead of the PG binder originally specified, if using recycled materials, and if the substitute PG binder and mixture made with the substitute PG binder meet the following:

- the substitute binder meets the specification requirements for the substitute binder grade in accordance with Section 300.2.10., "Performance-Graded Binders;" and
- the mixture has less than 10.0 mm of rutting on the Hamburg Wheel test ([Tex-242-F](#)) after the number of passes required for the originally specified binder. Use of substitute PG binders may only be allowed at the discretion of the Engineer if the Hamburg Wheel test results are between 10.0 mm and 12.5 mm.

Table 5
Allowable Substitute PG Binders and Maximum Recycled Binder Ratios

Originally Specified PG Binder	Allowable Substitute PG Binder for Surface Mixes	Allowable Substitute PG Binder for Intermediate and Base Mixes	Maximum Ratio of Recycled Binder ¹ to Total Binder (%)		
			Surface	Intermediate	Base
76-22 ^{4,5}	70-22	70-22	10.0	20.0	25.0
70-22 ^{2,5}	N/A	64-22	10.0	20.0	25.0
64-22 ^{2,3}	N/A	N/A	10.0	20.0	25.0
76-28 ^{4,5}	70-28	70-28	10.0	20.0	25.0
70-28 ^{2,5}	N/A	64-28	10.0	20.0	25.0
64-28 ^{2,3}	N/A	N/A	10.0	20.0	25.0

1. Combined recycled binder from RAP and RAS. RAS is not permitted in surface mixtures unless otherwise shown on the plans.
2. Binder substitution is not allowed for surface mixtures.
3. Binder substitution is not allowed for intermediate and base mixtures.
4. Use no more than 10.0% recycled binder in surface mixtures when using this originally specified PG binder.
5. Use no more than 20.0% recycled binder when using this originally specified PG binder for intermediate mixtures. Use no more than 25.0% recycled binder when using this originally specified PG binder for base mixtures.

3.

EQUIPMENT

Provide required or necessary equipment in accordance with Item 320, "Equipment for Asphalt Concrete Pavement."

4.

CONSTRUCTION

Produce, haul, place, and compact the specified paving mixture. In addition to tests required by the specification, Contractors may perform other QC tests as deemed necessary. At any time during the project, the Engineer may perform production and placement tests as deemed necessary in accordance with Item 5, "Control of the Work." Schedule and participate in a mandatory pre-paving meeting with the Engineer on or before the first day of paving unless otherwise shown on the plans.

4.1.

Certification. Personnel certified by the Department-approved hot-mix asphalt certification program must conduct all mixture designs, sampling, and testing in accordance with Table 6. Supply the Engineer with a list of certified personnel and copies of their current certificates before beginning production and when personnel changes are made. Provide a mixture design developed and signed by a Level 2 certified specialist. Provide Level 1A certified specialists at the plant during production operations. Provide Level 1B certified specialists to conduct placement tests. Provide AGG101 certified specialists for aggregate testing.

Table 6
Test Methods, Test Responsibility, and Minimum Certification Levels

Test Description	Test Method	Contractor	Engineer	Level ¹
1. Aggregate and Recycled Material Testing				
Sampling	Tex-221-F	✓	✓	1A/AGG101
Dry sieve	Tex-200-F , Part I	✓	✓	1A/AGG101
Washed sieve	Tex-200-F , Part II	✓	✓	1A/AGG101
Deleterious material	Tex-217-F , Parts I & III	✓	✓	AGG101
Decantation	Tex-217-F , Part II	✓	✓	AGG101
Los Angeles abrasion	Tex-410-A		✓	TxDOT
Magnesium sulfate soundness	Tex-411-A		✓	TxDOT
Micro-Deval abrasion	Tex-461-A		✓	AGG101
Crushed face count	Tex-460-A	✓	✓	AGG101
Flat and elongated particles	Tex-280-F	✓	✓	AGG101
Linear shrinkage	Tex-107-E	✓	✓	AGG101
Sand equivalent	Tex-203-F	✓	✓	AGG101
Organic impurities	Tex-408-A	✓	✓	AGG101
2. Asphalt Binder & Tack Coat Sampling				
Asphalt binder sampling	Tex-500-C , Part II	✓	✓	1A/1B
Tack coat sampling	Tex-500-C , Part III	✓	✓	1A/1B
3. Mix Design & Verification				
Design and JMF changes	Tex-204-F	✓	✓	2
Mixing	Tex-205-F	✓	✓	2
Molding (TGC)	Tex-206-F	✓	✓	1A
Molding (SGC)	Tex-241-F	✓	✓	1A
Laboratory-molded density	Tex-207-F , Parts I & VI	✓	✓	1A
Rice gravity	Tex-227-F , Part II	✓	✓	1A
Ignition oven correction factors ²	Tex-236-F , Part II	✓	✓	2
Indirect tensile strength	Tex-226-F	✓	✓	1A
Hamburg Wheel test	Tex-242-F	✓	✓	1A
Boil test	Tex-530-C	✓	✓	1A
4. Production Testing				
Selecting production random numbers	Tex-225-F , Part I		✓	1A
Mixture sampling	Tex-222-F	✓	✓	1A/1B
Molding (TGC)	Tex-206-F	✓	✓	1A
Molding (SGC)	Tex-241-F	✓	✓	1A
Laboratory-molded density	Tex-207-F , Parts I & VI	✓	✓	1A
Rice gravity	Tex-227-F , Part II	✓	✓	1A
Gradation & asphalt binder content ²	Tex-236-F , Part I	✓	✓	1A
Control charts	Tex-233-F	✓	✓	1A
Moisture content	Tex-212-F , Part II	✓	✓	1A/AGG101
Hamburg Wheel test	Tex-242-F	✓	✓	1A
Micro-Deval abrasion	Tex-461-A		✓	AGG101
Boil test	Tex-530-C	✓	✓	1A
Abson recovery	Tex-211-F		✓	TxDOT
5. Placement Testing				
Selecting placement random numbers	Tex-225-F , Part II		✓	1B
Trimming roadway cores	Tex-251-F , Parts I & II	✓	✓	1A/1B
In-place air voids	Tex-207-F , Parts I & VI	✓	✓	1A
In-place density (nuclear method)	Tex-207-F , Part III	✓		1B
Establish rolling pattern	Tex-207-F , Part IV	✓		1B
Control charts	Tex-233-F	✓	✓	1A
Ride quality measurement	Tex-1001-S	✓	✓	Note 3
Segregation (density profile)	Tex-207-F , Part V	✓	✓	1B
Longitudinal joint density	Tex-207-F , Part VII	✓	✓	1B
Thermal profile	Tex-244-F	✓	✓	1B
Shear Bond Strength Test	Tex-249-F		✓	TxDOT

1. Level 1A, 1B, AGG101, and 2 are certification levels provided by the Hot Mix Asphalt Center certification program.

2. Refer to Section 3076.4.9.2.3., "Production Testing," for exceptions to using an ignition oven.

3. Profiler and operator are required to be certified at the Texas A&M Transportation Institute facility when Surface Test Type B is specified.

4.2.

Reporting and Responsibilities. Use Department-provided templates to record and calculate all test data, including mixture design, production and placement QC/QA, control charts, thermal profiles, segregation density profiles, and longitudinal joint density. Obtain the current version of the templates at <http://www.txdot.gov/inside-txdot/forms-publications/consultants-contractors/forms/site-manager.html> or from the Engineer. The Engineer and the Contractor will provide any available test results to the other party when requested. The maximum allowable time for the Contractor and Engineer to exchange test data is as given in Table 7 unless otherwise approved. The Engineer and the Contractor will immediately report to the other party any test result that requires suspension of production or placement, a payment adjustment less than 1.000, or that fails to meet the specification requirements. Record and electronically submit all test results and pertinent information on Department-provided templates.

Subsequent sublots placed after test results are available to the Contractor, which require suspension of operations, may be considered unauthorized work. Unauthorized work will be accepted or rejected at the discretion of the Engineer in accordance with Article 5.3., "Conformity with Plans, Specifications, and Special Provisions."

Table 7
Reporting Schedule

Description	Reported By	Reported To	To Be Reported Within
Production Quality Control			
Gradation ¹	Contractor	Engineer	1 working day of completion of the subplot
Asphalt binder content ¹			
Laboratory-molded density ²			
Moisture content ³			
Boil test ³			
Production Quality Assurance			
Gradation ³	Engineer	Contractor	1 working day of completion of the subplot
Asphalt binder content ³			
Laboratory-molded density ¹			
Hamburg Wheel test ⁴			
Boil test ³			
Binder tests ⁴			
Placement Quality Control			
In-place air voids ²	Contractor	Engineer	1 working day of completion of the lot
Segregation ¹			
Longitudinal joint density ¹			
Thermal profile ¹			
Placement Quality Assurance			
In-place air voids ¹	Engineer	Contractor	1 working day after receiving the trimmed cores ⁵
Segregation ³			1 working day of completion of the lot
Longitudinal joint density ³			
Thermal profile ³			
Aging ratio ⁴			
Payment adjustment summary	Engineer	Contractor	2 working days of performing all required tests and receiving Contractor test data

1. These tests are required on every subplot.
2. Optional test. When performed on split samples, report the results as soon as they become available.
3. To be performed at the frequency specified in Table 16 or as shown on the plans.
4. To be reported as soon as the results become available.
5. 2 days are allowed if cores cannot be dried to constant weight within 1 day.

The Engineer will use the Department-provided template to calculate all payment adjustment factors for the lot. Sublot samples may be discarded after the Engineer and Contractor sign off on the payment adjustment summary documentation for the lot.

Use the procedures described in [Tex-233-F](#) to plot the results of all quality control (QC) and quality assurance (QA) testing. Update the control charts as soon as test results for each subplot become available. Make the control charts readily accessible at the field laboratory. The Engineer may suspend production for failure to update control charts.

- 4.3. **Quality Control Plan (QCP).** Develop and follow the QCP in detail. Obtain approval for changes to the QCP made during the project. The Engineer may suspend operations if the Contractor fails to comply with the QCP.

Submit a written QCP before the mandatory pre-paving meeting. Receive approval of the QCP before beginning production. Include the following items in the QCP:

- 4.3.1. **Project Personnel.** For project personnel, include:

- a list of individuals responsible for QC with authority to take corrective action;
- current contact information for each individual listed; and
- current copies of certification documents for individuals performing specified QC functions.

- 4.3.2. **Material Delivery and Storage.** For material delivery and storage, include:

- the sequence of material processing, delivery, and minimum quantities to assure continuous plant operations;
- aggregate stockpiling procedures to avoid contamination and segregation;
- frequency, type, and timing of aggregate stockpile testing to assure conformance of material requirements before mixture production; and
- procedure for monitoring the quality and variability of asphalt binder.

- 4.3.3. **Production.** For production, include:

- loader operation procedures to avoid contamination in cold bins;
- procedures for calibrating and controlling cold feeds;
- procedures to eliminate debris or oversized material;
- procedures for adding and verifying rates of each applicable mixture component (e.g., aggregate, asphalt binder, RAP, RAS, lime, liquid antistripping, WMA);
- procedures for reporting job control test results; and
- procedures to avoid segregation and drain-down in the silo.

- 4.3.4. **Loading and Transporting.** For loading and transporting, include:

- type and application method for release agents; and
- truck loading procedures to avoid segregation.

- 4.3.5. **Placement and Compaction.** For placement and compaction, include:

- proposed agenda for mandatory pre-paving meeting, including date and location;
- proposed paving plan (e.g., paving widths, joint offsets, and lift thicknesses);
- type and application method for release agents in the paver and on rollers, shovels, lutes, and other utensils;
- procedures for the transfer of mixture into the paver, while avoiding segregation and preventing material spillage;
- process to balance production, delivery, paving, and compaction to achieve continuous placement operations and good ride quality;
- paver operations (e.g., operation of wings, height of mixture in auger chamber) to avoid physical and thermal segregation and other surface irregularities; and
- procedures to construct quality longitudinal and transverse joints.

4.4. Mixture Design.

4.4.1. **Design Requirements.** The Contractor will design the mixture using a Superpave Gyrotory Compactor (SGC). A Texas Gyrotory Compactor (TGC) may be used when shown on the plans. Use the dense-graded design procedure provided in [Tex-204-F](#). Design the mixture to meet the requirements listed in Tables 1, 2, 3, 4, 5, 8, 9, and 10.

4.4.1.1. **Design Number of Gyration (Ndesign) When The SGC Is Used.** Design the mixture at 50 gyrations (Ndesign). Use a target laboratory-molded density of 96.0% to design the mixture; however, adjustments can be made to the Ndesign value as noted in Table 9. The Ndesign level may be reduced to at least 35 gyrations at the Contractor's discretion.

Use an approved laboratory from the Department's MPL to perform the Hamburg Wheel test, and provide results with the mixture design, or provide the laboratory mixture and request that the Department perform the Hamburg Wheel test. The Engineer will be allowed 10 working days to provide the Contractor with Hamburg Wheel test results on the laboratory mixture design.

The Engineer will provide the mixture design when shown on the plans. The Contractor may submit a new mixture design at any time during the project. The Engineer will verify and approve all mixture designs (JMF1) before the Contractor can begin production.

Provide the Engineer with a mixture design report using the Department-provided template. Include the following items in the report:

- the combined aggregate gradation, source, specific gravity, and percent of each material used;
- asphalt binder content and aggregate gradation of RAP and RAS stockpiles;
- the target laboratory-molded density (or Ndesign level when using the SGC);
- results of all applicable tests;
- the mixing and molding temperatures;
- the signature of the Level 2 person or persons that performed the design;
- the date the mixture design was performed; and
- a unique identification number for the mixture design.

Table 8
Master Gradation Limits (% Passing by Weight or Volume) and VMA Requirements

Sieve Size	B Fine Base	C Coarse Surface	D Fine Surface	F Fine Mixture
2"	–	–	–	–
1-1/2"	100.0 ¹	–	–	–
1"	98.0–100.0	100.0 ¹	–	–
3/4"	84.0–98.0	95.0–100.0	100.0 ¹	–
1/2"	–	–	98.0–100.0	100.0 ¹
3/8"	60.0–80.0	70.0–85.0	85.0–100.0	98.0–100.0
#4	40.0–60.0	43.0–63.0	50.0–70.0	70.0–90.0
#8	29.0–43.0	32.0–44.0	35.0–46.0	38.0–48.0
#30	13.0–28.0	14.0–28.0	15.0–29.0	12.0–27.0
#50	6.0–20.0	7.0–21.0	7.0–20.0	6.0–19.0
#200	2.0–7.0	2.0–7.0	2.0–7.0	2.0–7.0
Design VMA, % Minimum				
–	13.0	14.0	15.0	16.0
Production (Plant-Produced) VMA, % Minimum				
–	12.5	13.5	14.5	15.5

1. Defined as maximum sieve size. No tolerance allowed.

Table 9
Laboratory Mixture Design Properties

Mixture Property	Test Method	Requirement
Target laboratory-molded density, % (SGC)	Tex-207-F	96.0
Design gyrations (N _{design} for SGC)	Tex-241-F	50 ¹
Indirect tensile strength (dry), psi	Tex-226-F	85–200 ²
Boil test ³	Tex-530-C	–

- Adjust within a range of 35–100 gyrations when shown on the plans or specification or when mutually agreed between the Engineer and Contractor.
- The Engineer may allow the IDT strength to exceed 200 psi if the corresponding Hamburg Wheel rut depth is greater than 3.0 mm and less than 12.5 mm.
- Used to establish baseline for comparison to production results. May be waived when approved.

Table 10
Hamburg Wheel Test Requirements

High-Temperature Binder Grade	Test Method	Minimum # of Passes @ 12.5 mm ¹ Rut Depth, Tested @ 50°C
PG 64 or lower	Tex-242-F	10,000 ²
PG 70		15,000 ³
PG 76 or higher		20,000

- When the rut depth at the required minimum number of passes is less than 3 mm, the Engineer may require the Contractor to increase the target laboratory-molded density (TGC) by 0.5% to no more than 97.5% or lower the N_{design} level (SGC) to at least 35 gyrations.
- May be decreased to at least 5,000 passes when shown on the plans.
- May be decreased to at least 10,000 passes when shown on the plans.

- 4.4.1.2. **Target Laboratory-Molded Density When The TGC Is Used.** Design the mixture at a 96.5% target laboratory-molded density. Increase the target laboratory-molded density to 97.0% or 97.5% at the Contractor's discretion or when shown on the plans or specification.
- 4.4.2. **Job-Mix Formula Approval.** The job-mix formula (JMF) is the combined aggregate gradation, target laboratory-molded density (or N_{design} level), and target asphalt percentage used to establish target values for hot-mix production. JMF1 is the original laboratory mixture design used to produce the trial batch. When WMA is used, JMF1 may be designed and submitted to the Engineer without including the WMA additive. When WMA is used, document the additive or process used and recommended rate on the JMF1 submittal. The Engineer and the Contractor will verify JMF1 based on plant-produced mixture from the trial batch unless otherwise approved. The Engineer may accept an existing mixture design previously used on a Department project and may waive the trial batch to verify JMF1. The Department may require the Contractor to reimburse the Department for verification tests if more than 2 trial batches per design are required.
- 4.4.2.1. **Contractor's Responsibilities.**
- 4.4.2.1.1. **Providing Gyrotory Compactor.** Use a SGC calibrated in accordance with [Tex-241-F](#) to design the mixture in accordance with [Tex-204-F](#), Part IV, for molding production samples. Locate the SGC, if used, at the Engineer's field laboratory and make the SGC available to the Engineer for use in molding production samples. Furnish a TGC calibrated in accordance with [Tex-914-K](#) when shown on the plans to design the mixture in accordance with [Tex-204-F](#), Part I, for molding production samples.
- 4.4.2.1.2. **Gyrotory Compactor Correlation Factors.** Use [Tex-206-F](#), Part II, to perform a gyrotory compactor correlation when the Engineer uses a different gyrotory compactor. Apply the correlation factor to all subsequent production test results.
- 4.4.2.1.3. **Submitting JMF1.** Furnish a mix design report (JMF1) with representative samples of all component materials and request approval to produce the trial batch. Provide approximately 10,000 g of the design mixture if opting to have the Department perform the Hamburg Wheel test on the laboratory mixture, and request that the Department perform the test.

- 4.4.2.1.4. **Supplying Aggregates.** Provide approximately 40 lb. of each aggregate stockpile unless otherwise directed.
- 4.4.2.1.5. **Supplying Asphalt.** Provide at least 1 gal. of the asphalt material and enough quantities of any additives proposed for use.
- 4.4.2.1.6. **Ignition Oven Correction Factors.** Determine the aggregate and asphalt correction factors from the ignition oven in accordance with [Tex-236-F](#), Part II. Provide correction factors that are not more than 12 months old. Provide the Engineer with split samples of the mixtures before the trial batch production, including all additives (except water), and blank samples used to determine the correction factors for the ignition oven used for QA testing during production. Correction factors established from a previously approved mixture design may be used for the current mixture design if the mixture design and ignition oven are the same as previously used, unless otherwise directed.
- 4.4.2.1.7. **Boil Test.** Perform the test and retain the tested sample from [Tex-530-C](#) until completion of the project or as directed. Use this sample for comparison purposes during production. The Engineer may waive the requirement for the boil test.
- 4.4.2.1.8. **Trial Batch Production.** Provide a plant-produced trial batch upon receiving conditional approval of JMF1 and authorization to produce a trial batch, including the WMA additive or process if applicable, for verification testing of JMF1 and development of JMF2. Produce a trial batch mixture that meets the requirements in Table 4, Table 5, and Table 11. The Engineer may accept test results from recent production of the same mixture instead of a new trial batch.
- 4.4.2.1.9. **Trial Batch Production Equipment.** Use only equipment and materials proposed for use on the project to produce the trial batch.
- 4.4.2.1.10. **Trial Batch Quantity.** Produce enough quantity of the trial batch to ensure that the mixture meets the specification requirements.
- 4.4.2.1.11. **Number of Trial Batches.** Produce trial batches as necessary to obtain a mixture that meets the specification requirements.
- 4.4.2.1.12. **Trial Batch Sampling.** Obtain a representative sample of the trial batch and split it into 3 equal portions in accordance with [Tex-222-F](#). Label these portions as "Contractor," "Engineer," and "Referee." Deliver samples to the appropriate laboratory as directed.
- 4.4.2.1.13. **Trial Batch Testing.** Test the trial batch to ensure the mixture produced using the proposed JMF1 meets the mixture requirements in Table 11. Ensure the trial batch mixture is also in compliance with the Hamburg Wheel requirement in Table 10. Use a Department-approved laboratory to perform the Hamburg Wheel test on the trial batch mixture or request that the Department perform the Hamburg Wheel test. The Engineer will be allowed 10 working days to provide the Contractor with Hamburg Wheel test results on the trial batch. Provide the Engineer with a copy of the trial batch test results.
- 4.4.2.1.14. **Development of JMF2.** Evaluate the trial batch test results after the Engineer grants full approval of JMF1 based on results from the trial batch, determine the optimum mixture proportions, and submit as JMF2. Adjust the asphalt binder content or gradation to achieve the specified target laboratory-molded density. The asphalt binder content established for JMF2 is not required to be within any tolerance of the optimum asphalt binder content established for JMF1; however, mixture produced using JMF2 must meet the voids in mineral aggregates (VMA) requirements for production shown in Table 8. If the optimum asphalt binder content for JMF2 is more than 0.5% lower than the optimum asphalt binder content for JMF1, the Engineer may perform or require the Contractor to perform [Tex-226-F](#) on Lot 1 production to confirm the indirect tensile strength does not exceed 200 psi. Verify that JMF2 meets the mixture requirements in Table 5.
- 4.4.2.1.15. **Mixture Production.** Use JMF2 to produce Lot 1 as described in Section 3076.4.9.3.1.1., "Lot 1 Placement," after receiving approval for JMF2 and a passing result from the Department's or a Department-approved

laboratory's Hamburg Wheel test on the trial batch. If desired, proceed to Lot 1 production, once JMF2 is approved, at the Contractor's risk without receiving the results from the Department's Hamburg Wheel test on the trial batch.

Notify the Engineer if electing to proceed without Hamburg Wheel test results from the trial batch. Note that the Engineer may require up to the entire subplot of any mixture failing the Hamburg Wheel test to be removed and replaced at the Contractor's expense.

4.4.2.1.16. **Development of JMF3.** Evaluate the test results from Lot 1, determine the optimum mixture proportions, and submit as JMF3 for use in Lot 2.

4.4.2.1.17. **JMF Adjustments.** If JMF adjustments are necessary to achieve the specified requirements, make the adjustments before beginning a new lot. The adjusted JMF must:

- be provided to the Engineer in writing before the start of a new lot;
- be numbered in sequence to the previous JMF;
- meet the mixture requirements in Table 4 and Table 5;
- meet the master gradation limits shown in Table 8; and
- be within the operational tolerances of JMF2 listed in Table 11.

4.4.2.1.18. **Requesting Referee Testing.** Use referee testing, if needed, in accordance with Section 3076.4.9.1., "Referee Testing," to resolve testing differences with the Engineer.

Table 11
Operational Tolerances

Description	Test Method	Allowable Difference Between Trial Batch and JMF1 Target	Allowable Difference from Current JMF Target	Allowable Difference between Contractor and Engineer ¹
Individual % retained for #8 sieve and larger	Tex-200-F or Tex-236-F	Must be Within Master Grading Limits in Table 8	$\pm 5.0^{2,3}$	± 5.0
Individual % retained for sieves smaller than #8 and larger than #200			$\pm 3.0^{2,3}$	± 3.0
% passing the #200 sieve			$\pm 2.0^{2,3}$	± 1.6
Asphalt binder content, %	Tex-236-F	± 0.5	$\pm 0.3^3$	± 0.3
Laboratory-molded density, %	Tex-207-F	± 1.0	± 1.0	± 1.0
In-place air voids, %		N/A	N/A	± 1.0
Laboratory-molded bulk specific gravity		N/A	N/A	± 0.020
VMA, %, min	Tex-204-F	Note ⁴	Note ⁴	N/A
Theoretical maximum specific (Rice) gravity	Tex-227-F	N/A	N/A	± 0.020

1. Contractor may request referee testing only when values exceed these tolerances.
2. When within these tolerances, mixture production gradations may fall outside the master grading limits; however, the % passing the #200 will be considered out of tolerance when outside the master grading limits.
3. Only applies to mixture produced for Lot 1 and higher.
4. Test and verify that Table 8 requirements are met.

4.4.2.2. **Engineer's Responsibilities.**

4.4.2.2.1. **Gyratory Compactor.** For SGC mixtures designed in accordance with [Tex-204-F](#), Part IV, the Engineer will use a Department SGC, calibrated in accordance with [Tex-241-F](#), to mold samples for laboratory mixture design verification. For molding trial batch and production specimens, the Engineer will use the Contractor-provided SGC at the field laboratory or provide and use a Department SGC at an alternate location. The Engineer will make the Contractor-provided SGC in the Department field laboratory available to the Contractor for molding verification samples.

For TGC mixtures designed in accordance with [Tex-204-F](#), Part I, the Engineer will use a Department TGC, calibrated in accordance with [Tex-914-K](#), to mold samples for trial batch and production testing. The Engineer will make the Department TGC and the Department field laboratory available to the Contractor for molding verification samples, if requested by the Contractor.

4.4.2.2.2. **Conditional Approval of JMF1 and Authorizing Trial Batch.** The Engineer will review and verify conformance of the following information within 2 working days of receipt:

- the Contractor's mix design report (JMF1);
- the Contractor-provided Hamburg Wheel test results;
- all required materials including aggregates, asphalt, additives, and recycled materials; and
- the mixture specifications.

The Engineer will grant the Contractor conditional approval of JMF1 if the information provided on the paper copy of JMF1 indicates that the Contractor's mixture design meets the specifications. When the Contractor does not provide Hamburg Wheel test results with laboratory mixture design, 10 working days are allowed for conditional approval of JMF1. The Engineer will base full approval of JMF1 on the test results on mixture from the trial batch.

Unless waived, the Engineer will determine the Micro-Deval abrasion loss in accordance with Section 3076.2.1.1.2., "Micro-Deval Abrasion." If the Engineer's test results are pending after two working days, conditional approval of JMF1 will still be granted within two working days of receiving JMF1. When the Engineer's test results become available, they will be used for specification compliance.

After conditionally approving JMF1, including either Contractor- or Department-supplied Hamburg Wheel test results, the Contractor is authorized to produce a trial batch.

4.4.2.2.3. **Hamburg Wheel Testing of JMF1.** If the Contractor requests the option to have the Department perform the Hamburg Wheel test on the laboratory mixture, the Engineer will mold samples in accordance with [Tex-242-F](#) to verify compliance with the Hamburg Wheel test requirement in Table 10.

4.4.2.2.4. **Ignition Oven Correction Factors.** The Engineer will use the split samples provided by the Contractor to determine the aggregate and asphalt correction factors for the ignition oven used for QA testing during production in accordance with [Tex-236-F](#), Part II. Provide correction factors that are not more than 12 months old.

4.4.2.2.5. **Testing the Trial Batch.** Within 1 full working day, the Engineer will sample and test the trial batch to ensure that the mixture meets the requirements in Table 11. If the Contractor requests the option to have the Department perform the Hamburg Wheel test on the trial batch mixture, the Engineer will mold samples in accordance with [Tex-242-F](#) to verify compliance with the Hamburg Wheel test requirement in Table 10.

The Engineer will have the option to perform the following tests on the trial batch:

- [Tex-226-F](#), to verify that the indirect tensile strength meets the requirement shown in Table 9; and
- [Tex-530-C](#), to retain and use for comparison purposes during production.

4.4.2.2.6. **Full Approval of JMF1.** The Engineer will grant full approval of JMF1 and authorize the Contractor to proceed with developing JMF2 if the Engineer's results for the trial batch meet the requirements in Table 11. The Engineer will notify the Contractor that an additional trial batch is required if the trial batch does not meet these requirements.

4.4.2.2.7. **Approval of JMF2.** The Engineer will approve JMF2 within one working day if the mixture meets the requirements in Table 5 and the gradation meets the master grading limits shown in Table 8. The asphalt binder content established for JMF2 is not required to be within any tolerance of the optimum asphalt binder content established for JMF1; however, mixture produced using JMF2 must meet the VMA requirements shown in Table 8. If the optimum asphalt binder content for JMF2 is more than 0.5% lower than the optimum asphalt binder content for JMF1, the Engineer may perform or require the Contractor to perform [Tex-226-F](#) on Lot 1 production to confirm the indirect tensile strength does not exceed 200 psi.

4.4.2.2.8. **Approval of Lot 1 Production.** The Engineer will authorize the Contractor to proceed with Lot 1 production (using JMF2) as soon as a passing result is achieved from the Department's or a Department-approved laboratory's Hamburg Wheel test on the trial batch. The Contractor may proceed at its own risk with Lot 1 production without the results from the Hamburg Wheel test on the trial batch.

If the Department's or Department-approved laboratory's sample from the trial batch fails the Hamburg Wheel test, the Engineer will suspend production until further Hamburg Wheel tests meet the specified values. The Engineer may require up to the entire subplot of any mixture failing the Hamburg Wheel test be removed and replaced at the Contractor's expense.

4.4.2.2.9. **Approval of JMF3 and Subsequent JMF Changes.** JMF3 and subsequent JMF changes are approved if they meet the mixture requirements shown in Table 4, Table 5, and the master grading limits shown in Table 8, and are within the operational tolerances of JMF2 shown in Table 11.

4.5. **Production Operations.** Perform a new trial batch when the plant or plant location is changed. Take corrective action and receive approval to proceed after any production suspension for noncompliance to the specification. Submit a new mix design and perform a new trial batch when the asphalt binder content of:

- any RAP stockpile used in the mix is more than 0.5% higher than the value shown on the mixture design report; or
- RAS stockpile used in the mix is more than 2.0% higher than the value shown on the mixture design report.

4.5.1. **Storage and Heating of Materials.** Do not heat the asphalt binder above the temperatures specified in Item 300, "Asphalts, Oils, and Emulsions," or outside the manufacturer's recommended values. Provide the Engineer with daily records of asphalt binder and hot-mix asphalt discharge temperatures (in legible and discernible increments) in accordance with Item 320, "Equipment for Asphalt Concrete Pavement," unless otherwise directed. Do not store mixture for a period long enough to affect the quality of the mixture, nor in any case longer than 12 hr. unless otherwise approved.

4.5.2. **Mixing and Discharge of Materials.** Notify the Engineer of the target discharge temperature and produce the mixture within 25°F of the target. Monitor the temperature of the material in the truck before shipping to ensure that it does not exceed the maximum production temperatures listed in Table 12 (or 275°F for WMA). The Department will not pay for or allow placement of any mixture produced above the maximum production temperatures listed in Table 12.

Table 12
Maximum Production Temperature

High-Temperature Binder Grade ¹	Maximum Production Temperature
PG 64	325°F
PG 70	335°F
PG 76	345°F

1. The high-temperature binder grade refers to the high-temperature grade of the virgin asphalt binder used to produce the mixture.

Produce WMA within the target discharge temperature range of 215°F and 275°F when WMA is required. Take corrective action any time the discharge temperature of the WMA exceeds the target discharge range. The Engineer may suspend production operations if the Contractor's corrective action is not successful at controlling the production temperature within the target discharge range. Note that when WMA is produced, it may be necessary to adjust burners to ensure complete combustion such that no burner fuel residue remains in the mixture.

Control the mixing time and temperature so that substantially all moisture is removed from the mixture before discharging from the plant. Determine the moisture content, if requested, by oven-drying in accordance with

[Tex-212-F](#), Part II, and verify that the mixture contains no more than 0.2% of moisture by weight. Obtain the sample immediately after discharging the mixture into the truck, and perform the test promptly.

- 4.6. **Hauling Operations.** Clean all truck beds before use to ensure that mixture is not contaminated. Use a release agent shown on the Department's MPL to coat the inside bed of the truck when necessary.

Use equipment for hauling as defined in Section 3076.4.7.3.3., "Hauling Equipment." Use other hauling equipment only when allowed.

- 4.7. **Placement Operations.** Collect haul tickets from each load of mixture delivered to the project and provide the Department's copy to the Engineer approximately every hour, or as directed. Use a hand-held thermal camera or infrared thermometer, when a thermal imaging system is not used, to measure and record the internal temperature of the mixture as discharged from the truck or Material Transfer Device (MTD) before or as the mix enters the paver and an approximate station number or GPS coordinates on each ticket. Calculate the daily yield and cumulative yield for the specified lift and provide to the Engineer at the end of paving operations for each day unless otherwise directed. The Engineer may suspend production if the Contractor fails to produce and provide haul tickets and yield calculations by the end of paving operations for each day.

Prepare the surface by removing raised pavement markers and objectionable material such as moisture, dirt, sand, leaves, and other loose impediments from the surface before placing mixture. Remove vegetation from pavement edges. Place the mixture to meet the typical section requirements and produce a smooth, finished surface with a uniform appearance and texture. Offset longitudinal joints of successive courses of hot-mix by at least 6 in. Place mixture so that longitudinal joints on the surface course coincide with lane lines and are not placed in the wheel path, or as directed. Ensure that all finished surfaces will drain properly. Place the mixture at the rate or thickness shown on the plans. The Engineer will use the guidelines in Table 13 to determine the compacted lift thickness of each layer when multiple lifts are required. The thickness determined is based on the rate of 110 lb./sq. yd. for each inch of pavement unless otherwise shown on the plans.

Table 13
Compacted Lift Thickness and Required Core Height

Mixture Type	Compacted Lift Thickness Guidelines		Minimum Untrimmed Core Height (in.) Eligible for Testing
	Minimum (in.)	Maximum (in.)	
B	2.50	5.00	1.75
C	2.00	4.00	1.50
D	1.50	3.00	1.25
F	1.25	2.50	1.25

- 4.7.1. **Weather Conditions.**

- 4.7.1.1. **When Using a Thermal Imaging System.** Place mixture when the roadway surface is dry and the roadway surface temperature is at or above the temperatures listed in Table 14A. The Engineer may restrict the Contractor from paving surface mixtures if the ambient temperature is likely to drop below 32°F within 12 hr. of paving. Place mixtures only when weather conditions and moisture conditions of the roadway surface are suitable as determined by the Engineer. Provide output data from the thermal imaging system to demonstrate to the Engineer that no recurring severe thermal segregation exists in accordance with Section 3076.4.7.3.1.2., "Thermal Imaging System."

Table 14A
Minimum Pavement Surface Temperatures

High-Temperature Binder Grade ¹	Minimum Pavement Surface Temperatures (°F)	
	Subsurface Layers or Night Paving Operations	Surface Layers Placed in Daylight Operations
PG 64	35	40
PG 70	45 ²	50 ²
PG 76	45 ²	50 ²

1. The high-temperature binder grade refers to the high-temperature grade of the virgin asphalt binder used to produce the mixture.
2. Contractors may pave at temperatures 10°F lower than these values when a chemical WMA additive is used as a compaction aid in the mixture or when using WMA.

4.7.1.2.

When Not Using a Thermal Imaging System. When using a thermal camera instead of the thermal imaging system, place mixture when the roadway surface temperature is at or above the temperatures listed in Table 14B unless otherwise approved or as shown on the plans. Measure the roadway surface temperature with a hand-held thermal camera or infrared thermometer. The Engineer may allow mixture placement to begin before the roadway surface reaches the required temperature if conditions are such that the roadway surface will reach the required temperature within 2 hr. of beginning placement operations. Place mixtures only when weather conditions and moisture conditions of the roadway surface are suitable as determined by the Engineer. The Engineer may restrict the Contractor from paving if the ambient temperature is likely to drop below 32°F within 12 hr. of paving.

Table 14B
Minimum Pavement Surface Temperatures

High-Temperature Binder Grade ¹	Minimum Pavement Surface Temperatures (°F)	
	Subsurface Layers or Night Paving Operations	Surface Layers Placed in Daylight Operations
PG 64	45	50
PG 70	55 ²	60 ²
PG 76	60 ²	60 ²

1. The high-temperature binder grade refers to the high-temperature grade of the virgin asphalt binder used to produce the mixture.
2. Contractors may pave at temperatures 10°F lower than these values when a chemical WMA additive is used as a compaction aid in the mixture, when using WMA, or utilizing a paving process with equipment that eliminates thermal segregation. In such cases, for each sublot and in the presence of the Engineer, use a hand-held thermal camera operated in accordance with [Tex-244-F](#) to demonstrate to the satisfaction of the Engineer that the uncompacted mat has no more than 10°F of thermal segregation.

4.7.2.

Tack Coat.

4.7.2.1.

Application. Clean the surface before placing the tack coat. The Engineer will set the rate between 0.04 and 0.10 gal. of residual asphalt per square yard of surface area. Apply a uniform tack coat at the specified rate unless otherwise directed. Apply the tack coat in a uniform manner to avoid streaks and other irregular patterns. Apply the tack coat to all surfaces that will come in contact with the subsequent HMA placement, unless otherwise directed. Allow adequate time for emulsion to break completely before placing any material. Prevent splattering of tack coat when placed adjacent to curb, gutter, and structures. Do not dilute emulsified asphalts at the terminal, in the field, or at any other location before use.

4.7.2.2.

Sampling. The Engineer will obtain at least one sample of the tack coat binder per project in accordance with [Tex-500-C](#), Part III, and test it to verify compliance with Item 300, "Asphalts, Oils, and Emulsions." The Engineer will notify the Contractor when the sampling will occur and will witness the collection of the sample from the asphalt distributor immediately before use.

For emulsions, the Engineer may test as often as necessary to ensure the residual of the emulsion is greater than or equal to the specification requirement in Item 300, "Asphalts, Oils, and Emulsions."

- 4.7.3. **Lay-Down Operations.** Use the placement temperatures in Table 15 to establish the minimum placement temperature of the mixture delivered to the paver.

Table 15
Minimum Mixture Placement Temperature

High-Temperature Binder Grade ¹	Minimum Placement Temperature (Before Entering Paver) ^{2,3}
PG 64	260°F
PG 70	270°F
PG 76	280°F

1. The high-temperature binder grade refers to the high-temperature grade of the virgin asphalt binder used to produce the mixture.
2. Minimum placement temperatures may be reduced 10°F if using a chemical WMA additive as a compaction aid.
3. When using WMA, the minimum placement temperature is 215°F.

- 4.7.3.1. **Thermal Profile.** Use a hand-held thermal camera or a thermal imaging system to obtain a continuous thermal profile in accordance with [Tex-244-F](#). Thermal profiles are not applicable in areas described in Section 3076.4.9.3.1.4., “Miscellaneous Areas.”
- 4.7.3.1.1. **Thermal Segregation.**
- 4.7.3.1.1.1. **Moderate.** Any areas that have a temperature differential greater than 25°F, but not exceeding 50°F, are deemed as moderate thermal segregation.
- 4.7.3.1.1.2. **Severe.** Any areas that have a temperature differential greater than 50°F are deemed as severe thermal segregation.
- 4.7.3.1.2. **Thermal Imaging System.** Review the output results when a thermal imaging system is used, and provide the automated report described in [Tex-244-F](#) to the Engineer daily unless otherwise directed. Modify the paving process as necessary to eliminate any recurring (moderate or severe) thermal segregation identified by the thermal imaging system. The Engineer may suspend paving operations if the Contractor cannot successfully modify the paving process to eliminate recurring severe thermal segregation. Density profiles are not required and not applicable when using a thermal imaging system. Provide the Engineer with electronic copies of all daily data files that can be used with the thermal imaging system software to generate temperature profile plots daily or upon completion of the project or as requested by the Engineer.
- 4.7.3.1.3. **Thermal Camera.** When using a thermal camera instead of the thermal imaging system, take immediate corrective action to eliminate recurring moderate thermal segregation when a hand-held thermal camera is used. Evaluate areas with moderate thermal segregation by performing density profiles in accordance with Section 3076.4.9.3.3.2., “Segregation (Density Profile).” Provide the Engineer with the thermal profile of every subplot within one working day of the completion of each lot. When requested by the Engineer, provide the thermal images generated using the thermal camera. Report the results of each thermal profile in accordance with Section 3076.4.2., “Reporting and Responsibilities.” The Engineer will use a hand-held thermal camera to obtain a thermal profile at least once per project. No production or placement payment adjustments greater than 1.000 will be paid for any subplot that contains severe thermal segregation. Suspend operations and take immediate corrective action to eliminate severe thermal segregation unless otherwise directed. Resume operations when the Engineer determines that subsequent production will meet the requirements of this Section. Evaluate areas with severe thermal segregation by performing density profiles in accordance with Section 3076.4.9.3.3.2., “Segregation (Density Profile).” Remove and replace the material in any areas that have both severe thermal segregation and a failing result for Segregation (Density Profile) unless otherwise directed. The subplot in question may receive a production and placement payment adjustment greater than 1.000, if applicable, when the defective material is successfully removed and replaced.
- 4.7.3.2. **Windrow Operations.** Operate windrow pickup equipment so that when hot-mix is placed in windrows, substantially all the mixture deposited on the roadbed is picked up and loaded into the paver.

4.7.3.3. **Hauling Equipment.** Use belly dumps, live bottom, or end dump trucks to haul and transfer mixture; however, with exception of paving miscellaneous areas, end dump trucks are only allowed when used in conjunction with an MTD with remixing capability or when a thermal imaging system is used unless otherwise allowed.

4.7.3.4. **Screed Heaters.** Turn off screed heaters to prevent overheating of the mat if the paver stops for more than 5 min. The Engineer may evaluate the suspect area in accordance with Section 3076.4.9.3.3.4., "Recovered Asphalt Dynamic Shear Rheometer (DSR)," if the screed heater remains on for more than 5 min. while the paver is stopped.

4.8. **Compaction.** Compact the pavement uniformly to contain between 3.8% and 8.5% in-place air voids. Take immediate corrective action to bring the operation within 3.8% and 8.5% when the in-place air voids exceed the range of these tolerances. The Engineer will allow paving to resume when the proposed corrective action is likely to yield between 3.8% and 8.5% in-place air voids.

Obtain cores in areas placed under Exempt Production, as directed, at locations determined by the Engineer. The Engineer may test these cores and suspend operations or require removal and replacement if the in-place air voids are less than 2.7% or more than 9.9%. Areas defined in Section 3076.4.9.3.1.4., "Miscellaneous Areas," are not subject to in-place air void determination.

Furnish the type, size, and number of rollers required for compaction as approved. Use additional rollers as required to remove any roller marks. Use only water or an approved release agent on rollers, tamps, and other compaction equipment unless otherwise directed.

Use the control strip method shown in [Tex-207-F](#), Part IV, on the first day of production to establish the rolling pattern that will produce the desired in-place air voids unless otherwise directed.

Use tamps to thoroughly compact the edges of the pavement along curbs, headers, and similar structures and in locations that will not allow thorough compaction with rollers. The Engineer may require rolling with a trench roller on widened areas, in trenches, and in other limited areas.

Complete all compaction operations before the pavement temperature drops below 160°F unless otherwise allowed. The Engineer may allow compaction with a light finish roller operated in static mode for pavement temperatures below 160°F.

Allow the compacted pavement to cool to 160°F or lower before opening to traffic unless otherwise directed. Sprinkle the finished mat with water or limewater, when directed, to expedite opening the roadway to traffic.

4.9. **Acceptance Plan.** Payment adjustments for the material will be in accordance with Article 3076.6., "Payment."

Sample and test the hot-mix on a lot and subplot basis. Suspend production until test results or other information indicates to the satisfaction of the Engineer that the next material produced or placed will result in payment factors of at least 1.000, if the production payment factor given in Section 3076.6.1., "Production Payment Adjustment Factors," for two consecutive lots or the placement pay factor given in Section 3076.6.2., "Placement Payment Adjustment Factors," for two consecutive lots is below 1.000.

4.9.1. **Referee Testing.** The Materials and Tests Division is the referee laboratory. The Contractor may request referee testing if a "remove and replace" condition is determined based on the Engineer's test results, or if the differences between Contractor and Engineer test results exceed the maximum allowable difference shown in Table 11 and the differences cannot be resolved. The Contractor may also request referee testing if the Engineer's test results require suspension of production and the Contractor's test results are within specification limits. Make the request within five working days after receiving test results and cores from the Engineer. Referee tests will be performed only on the subplot in question and only for the particular tests in question. Allow 10 working days from the time the referee laboratory receives the samples for test results to

be reported. The Department may require the Contractor to reimburse the Department for referee tests if more than three referee tests per project are required and the Engineer's test results are closer to the referee test results than the Contractor's test results.

The Materials and Tests Division will determine the laboratory-molded density based on the molded specific gravity and the maximum theoretical specific gravity of the referee sample. The in-place air voids will be determined based on the bulk specific gravity of the cores, as determined by the referee laboratory and the Engineer's average maximum theoretical specific gravity for the lot. With the exception of "remove and replace" conditions, referee test results are final and will establish payment adjustment factors for the subplot in question. The Contractor may decline referee testing and accept the Engineer's test results when the placement payment adjustment factor for any subplot results in a "remove and replace" condition. Placement sublots subject to be removed and replaced will be further evaluated in accordance with Section 3076.6.2.2., "Placement Sublots Subject to Removal and Replacement."

4.9.2. **Production Acceptance.**

4.9.2.1. **Production Lot.** A production lot consists of four equal sublots. The default quantity for Lot 1 is 1,000 tons; however, when requested by the Contractor, the Engineer may increase the quantity for Lot 1 to no more than 4,000 tons. The Engineer will select subsequent lot sizes based on the anticipated daily production such that approximately three to four sublots are produced each day. The lot size will be between 1,000 tons and 4,000 tons. The Engineer may change the lot size before the Contractor begins any lot.

If the optimum asphalt binder content for JMF2 is more than 0.5% lower than the optimum asphalt binder content for JMF1, the Engineer may perform or require the Contractor to perform [Tex-226-F](#) on Lot 1 to confirm the indirect tensile strength does not exceed 200 psi. Take corrective action to bring the mixture within specification compliance if the indirect tensile strength exceeds 200 psi unless otherwise directed.

4.9.2.1.1. **Incomplete Production Lots.** If a lot is begun but cannot be completed, such as on the last day of production or in other circumstances deemed appropriate, the Engineer may close the lot. Adjust the payment for the incomplete lot in accordance with Section 3076.6.1., "Production Payment Adjustment Factors." Close all lots within five working days unless otherwise allowed.

4.9.2.2. **Production Sampling.**

4.9.2.2.1. **Mixture Sampling.** Obtain hot-mix samples from trucks at the plant in accordance with [Tex-222-F](#). The sampler will split each sample into three equal portions in accordance with [Tex-200-F](#) and label these portions as "Contractor," "Engineer," and "Referee." The Engineer will perform or witness the sample splitting and take immediate possession of the samples labeled "Engineer" and "Referee." The Engineer will maintain the custody of the samples labeled "Engineer" and "Referee" until the Department's testing is completed.

4.9.2.2.1.1. **Random Sample.** At the beginning of the project, the Engineer will select random numbers for all production sublots. Determine sample locations in accordance with [Tex-225-F](#). Take one sample for each subplot at the randomly selected location. The Engineer will perform or witness the sampling of production sublots.

4.9.2.2.1.2. **Blind Sample.** For one subplot per lot, the Engineer will obtain and test a "blind" sample instead of the random sample collected by the Contractor. Test either the "blind" or the random sample; however, referee testing (if applicable) will be based on a comparison of results from the "blind" sample. The location of the Engineer's "blind" sample will not be disclosed to the Contractor. The Engineer's "blind" sample may be randomly selected in accordance with [Tex-225-F](#) for any subplot or selected at the discretion of the Engineer. The Engineer will use the Contractor's split sample for sublots not sampled by the Engineer.

4.9.2.2.2. **Informational Shear Bond Strength Testing.** Select one random subplot from Lot 2 or higher for shear bond strength testing. Obtain full depth cores in accordance with [Tex-249-F](#). Label the cores with the Control Section Job (CSJ), producer of the tack coat, mix type, shot rate, lot, and subplot number and provide to the

Engineer. The Engineer will ship the cores to the Materials and Tests Division or district laboratory for shear bond strength testing. Results from these tests will not be used for specification compliance.

- 4.9.2.2.3. **Asphalt Binder Sampling.** Obtain a 1-qt. sample of the asphalt binder witnessed by the Engineer for each lot of mixture produced. The Contractor will notify the Engineer when the sampling will occur. Obtain the sample at approximately the same time the mixture random sample is obtained. Sample from a port located immediately upstream from the mixing drum or pug mill and upstream from the introduction of any additives in accordance with [Tex-500-C](#), Part II. Label the can with the corresponding lot and subplot numbers, producer, producer facility location, grade, district, date sampled, and project information including highway and CSJ. The Engineer will retain these samples for one year. The Engineer may also obtain independent samples. If obtaining an independent asphalt binder sample and upon request of the Contractor, the Engineer will split a sample of the asphalt binder with the Contractor.

At least once per project, the Engineer will collect split samples of each binder grade and source used. The Engineer will submit one split sample to MTD to verify compliance with Item 300, "Asphalts, Oils, and Emulsions" and will retain the other split sample for one year.

- 4.9.2.3. **Production Testing.** The Contractor and Engineer must perform production tests in accordance with Table 16. The Contractor has the option to verify the Engineer's test results on split samples provided by the Engineer. Determine compliance with operational tolerances listed in Table 11 for all sublots.

Take immediate corrective action if the Engineer's laboratory-molded density on any subplot is less than 95.0% or greater than 97.0% to bring the mixture within these tolerances. The Engineer may suspend operations if the Contractor's corrective actions do not produce acceptable results. The Engineer will allow production to resume when the proposed corrective action is likely to yield acceptable results.

The Engineer may allow alternate methods for determining the asphalt binder content and aggregate gradation if the aggregate mineralogy is such that [Tex-236-F](#), Part I does not yield reliable results. Provide evidence that results from [Tex-236-F](#), Part I are not reliable before requesting permission to use an alternate method unless otherwise directed. Use the applicable test procedure as directed if an alternate test method is allowed.

Table 16
Production and Placement Testing Frequency

Description	Test Method	Minimum Contractor Testing Frequency	Minimum Engineer Testing Frequency
Individual % retained for #8 sieve and larger	Tex-200-F or Tex-236-F	1 per subplot	1 per 12 sublots ¹
Individual % retained for sieves smaller than #8 and larger than #200			
% passing the #200 sieve			
Laboratory-molded density	Tex-207-F	N/A	1 per subplot ¹
Laboratory-molded bulk specific gravity			
In-place air voids			
VMA	Tex-204-F	1 per subplot	1 per project
Segregation (density profile) ²	Tex-207-F , Part V		
Longitudinal joint density	Tex-207-F , Part VII	When directed	1 per subplot ¹
Moisture content	Tex-212-F , Part II	N/A	
Theoretical maximum specific (Rice) gravity	Tex-227-F	1 per subplot	1 per lot ¹
Asphalt binder content	Tex-236-F	N/A	1 per project
Hamburg Wheel test	Tex-242-F	N/A	
Recycled Asphalt Shingles (RAS) ³	Tex-217-F , Part III	1 per subplot	
Thermal profile ²	Tex-244-F	1 per lot (sample only) ⁴	
Asphalt binder sampling and testing	Tex-500-C , Part II	N/A	
Tack coat sampling and testing	Tex-500-C , Part III	1 per lot	
Boil test ⁵	Tex-530-C	1 per project (sample only)	
Shear Bond Strength Test ⁶	Tex-249-F		

1. For production defined in Section 3076.4.9.4., "Exempt Production," the Engineer will test one per day if 100 tons or more are produced. For Exempt Production, no testing is required when less than 100 tons are produced.
2. Not required when a thermal imaging system is used.
3. Testing performed by the Materials and Tests Division or designated laboratory.
4. Obtain witnessed by the Engineer. The Engineer will retain these samples for one year.
5. The Engineer may reduce or waive the sampling and testing requirements based on a satisfactory test history.
6. Testing performed by the Materials and Tests Division or District for informational purposes only.

4.9.2.4. **Operational Tolerances.** Control the production process within the operational tolerances listed in Table 11. When production is suspended, the Engineer will allow production to resume when test results or other information indicates the next mixture produced will be within the operational tolerances.

4.9.2.4.1. **Gradation.** Suspend operation and take corrective action if any aggregate is retained on the maximum sieve size shown in Table 8. A subplot is defined as out of tolerance if either the Engineer's or the Contractor's test results are out of operational tolerance. Suspend production when test results for gradation exceed the operational tolerances in Table 11 for three consecutive sublots on the same sieve or four consecutive sublots on any sieve unless otherwise directed. The consecutive sublots may be from more than one lot.

4.9.2.4.2. **Asphalt Binder Content.** A subplot is defined as out of operational tolerance if either the Engineer's or the Contractor's test results exceed the values listed in Table 11. No production or placement payment adjustments greater than 1.000 will be paid for any subplot that is out of operational tolerance for asphalt binder content. Suspend production and shipment of the mixture if the Engineer's or the Contractor's asphalt binder content deviates from the current JMF by more than 0.5% for any subplot.

4.9.2.4.3. **Voids in Mineral Aggregates (VMA).** The Engineer will determine the VMA for every subplot. For sublots when the Engineer does not determine asphalt binder content, the Engineer will use the asphalt binder content results from QC testing performed by the Contractor to determine VMA.

Take immediate corrective action if the VMA value for any subplot is less than the minimum VMA requirement for production listed in Table 8. Suspend production and shipment of the mixture if the Engineer's VMA results on two consecutive sublots are below the minimum VMA requirement for production listed in Table 8. No production or placement payment adjustments greater than 1.000 will be paid for any subplot that does not

meet the minimum VMA requirement for production listed in Table 8 based on the Engineer's VMA determination.

Suspend production and shipment of the mixture if the Engineer's VMA result is more than 0.5% below the minimum VMA requirement for production listed in Table 8. In addition to suspending production, the Engineer may require removal and replacement or may allow the subplot to be left in place without payment.

- 4.9.2.4.4. **Hamburg Wheel Test.** The Engineer may perform a Hamburg Wheel test at any time during production, including when the boil test indicates a change in quality from the materials submitted for JMF1. In addition to testing production samples, the Engineer may obtain cores and perform Hamburg Wheel tests on any areas of the roadway where rutting is observed. Suspend production until further Hamburg Wheel tests meet the specified values when the production or core samples fail the Hamburg Wheel test criteria in Table 10. Core samples, if taken, will be obtained from the center of the finished mat or other areas excluding the vehicle wheel paths. The Engineer may require up to the entire subplot of any mixture failing the Hamburg Wheel test to be removed and replaced at the Contractor's expense.

If the Department's or Department approved laboratory's Hamburg Wheel test results in a "remove and replace" condition, the Contractor may request that the Department confirm the results by re-testing the failing material. The Materials and Tests Division will perform the Hamburg Wheel tests and determine the final disposition of the material in question based on the Department's test results.

- 4.9.2.5. **Individual Loads of Hot-Mix.** The Engineer can reject individual truckloads of hot-mix. When a load of hot-mix is rejected for reasons other than temperature, contamination, or excessive uncoated particles, the Contractor may request that the rejected load be tested. Make this request within 4 hr. of rejection. The Engineer will sample and test the mixture. If test results are within the operational tolerances shown in Table 11, payment will be made for the load. If test results are not within operational tolerances, no payment will be made for the load.

4.9.3. **Placement Acceptance.**

- 4.9.3.1. **Placement Lot.** A placement lot consists of four placement sublots. A placement subplot consists of the area placed during a production subplot.

- 4.9.3.1.1. **Lot 1 Placement.** Placement payment adjustments greater than 1.000 for Lot 1 will be in accordance with Section 3076.6.2., "Placement Payment Adjustment Factors"; however, no placement adjustment less than 1.000 will be assessed for any subplot placed in Lot 1 when the in-place air voids are greater than or equal to 2.7% and less than or equal to 9.9%. Remove and replace any subplot with in-place air voids less than 2.7% or greater than 9.9%.

- 4.9.3.1.2. **Incomplete Placement Lots.** An incomplete placement lot consists of the area placed as described in Section 3076.4.9.2.1.1., "Incomplete Production Lots," excluding areas defined in Section 3076.4.9.3.1.4., "Miscellaneous Areas." Placement sampling is required if the random sample plan for production resulted in a sample being obtained from an incomplete production subplot.

- 4.9.3.1.3. **Shoulders, Ramps, Etc.** Shoulders, ramps, intersections, acceleration lanes, deceleration lanes, and turn lanes are subject to in-place air void determination and payment adjustments unless designated on the plans as not eligible for in-place air void determination. Intersections may be considered miscellaneous areas when determined by the Engineer.

- 4.9.3.1.4. **Miscellaneous Areas.** Miscellaneous areas include areas that typically involve significant handwork or discontinuous paving operations, such as temporary detours, driveways, mailbox turnouts, crossovers, gores, spot level-up areas, and other similar areas. Temporary detours are subject to in-place air void determination when shown on the plans. Miscellaneous areas also include level-ups and thin overlays when the layer thickness specified on the plans is less than the minimum untrimmed core height eligible for testing shown in Table 13. The specified layer thickness is based on the rate of 110 lb./sq. yd. for each inch of

pavement unless another rate is shown on the plans. When “level up” is listed as part of the item bid description code, a payment adjustment factor of 1.000 will be assigned for all placement sublots as described in Article 3076.6, “Payment.” Miscellaneous areas are not eligible for random placement sampling locations. Compact miscellaneous areas in accordance with Section 3076.4.8., “Compaction.” Miscellaneous areas are not subject to in-place air void determination, thermal profiles testing, segregation (density profiles), or longitudinal joint density evaluations.

4.9.3.2.

Placement Sampling. The Engineer will select random numbers for all placement sublots at the beginning of the project. The Engineer will provide the Contractor with the placement random numbers immediately after the subplot is completed. Mark the roadway location at the completion of each subplot and record the station number. Determine one random sample location for each placement subplot in accordance with [Tex-225-F](#). Adjust the random sample location by no more than necessary to achieve a 2-ft. clearance if the location is within 2 ft. of a joint or pavement edge.

Shoulders, ramps, intersections, acceleration lanes, deceleration lanes, and turn lanes are always eligible for selection as a random sample location; however, if a random sample location falls on one of these areas and the area is designated on the plans as not subject to in-place air void determination, cores will not be taken for the subplot and a 1.000 pay factor will be assigned to that subplot.

Provide the equipment and means to obtain and trim roadway cores on site. On-site is defined as in close proximity to where the cores are taken. Obtain the cores within one working day of the time the placement subplot is completed unless otherwise approved. Obtain two 6-in. diameter cores side-by-side from within 1 ft. of the random location provided for the placement subplot. For Type D and Type F mixtures, 4-in. diameter cores are allowed. Mark the cores for identification, measure and record the untrimmed core height, and provide the information to the Engineer. The Engineer will witness the coring operation and measurement of the core thickness. Visually inspect each core and verify that the current paving layer is bonded to the underlying layer. Take corrective action if an adequate bond does not exist between the current and underlying layer to ensure that an adequate bond will be achieved during subsequent placement operations.

Trim the cores immediately after obtaining the cores from the roadway in accordance with [Tex-251-F](#) if the core heights meet the minimum untrimmed value listed in Table 13. Trim the cores on site in the presence of the Engineer. Use a permanent marker or paint pen to record the lot and subplot numbers on each core as well as the designation as Core A or B. The Engineer may require additional information to be marked on the core and may choose to sign or initial the core. The Engineer will take custody of the cores immediately after witnessing the trimming of the cores and will retain custody of the cores until the Department’s testing is completed. Before turning the trimmed cores over to the Engineer, the Contractor may wrap the trimmed cores or secure them in a manner that will reduce the risk of possible damage occurring during transport by the Engineer. After testing, the Engineer will return the cores to the Contractor.

The Engineer may have the cores transported back to the Department’s laboratory at the HMA plant via the Contractor’s haul truck or other designated vehicle. In such cases where the cores will be out of the Engineer’s possession during transport, the Engineer will use Department-provided security bags and the Roadway Core Custody protocol located at <http://www.txdot.gov/business/specifications.htm> to provide a secure means and process that protects the integrity of the cores during transport.

Decide whether to include the pair of cores in the air void determination for that subplot if the core height before trimming is less than the minimum untrimmed value shown in Table 13. Trim the cores as described above before delivering to the Engineer if electing to have the cores included in the air void determination. Deliver untrimmed cores to the Engineer and inform the Engineer of the decision to not have the cores included in air void determination if electing to not have the cores included in air void determination. The placement pay factor for the subplot will be 1.000 if cores will not be included in air void determination.

Instead of the Contractor trimming the cores on site immediately after coring, the Engineer and the Contractor may mutually agree to have the trimming operations performed at an alternate location such as a field laboratory or other similar location. In such cases, the Engineer will take possession of the cores

immediately after they are obtained from the roadway and will retain custody of the cores until testing is completed. Either the Department or Contractor representative may perform trimming of the cores. The Engineer will witness all trimming operations in cases where the Contractor representative performs the trimming operation.

Dry the core holes and tack the sides and bottom immediately after obtaining the cores. Fill the hole with the same type of mixture and properly compact the mixture. Repair core holes with other methods when approved.

4.9.3.3. **Placement Testing.** Perform placement tests in accordance with Table 16. After the Engineer returns the cores, the Contractor may test the cores to verify the Engineer's test results for in-place air voids. The allowable differences between the Contractor's and Engineer's test results are listed in Table 11.

4.9.3.3.1. **In-Place Air Voids.** The Engineer will measure in-place air voids in accordance with [Tex-207-F](#) and [Tex-227-F](#). Before drying to a constant weight, cores may be pre-dried using a CoreDry or similar vacuum device to remove excess moisture. The Engineer will average the values obtained for all sublots in the production lot to determine the theoretical maximum specific gravity. The Engineer will use the average air void content for in-place air voids.

The Engineer will use the vacuum method to seal the core if required by [Tex-207-F](#). The Engineer will use the test results from the unsealed core to determine the placement payment adjustment factor if the sealed core yields a higher specific gravity than the unsealed core. After determining the in-place air void content, the Engineer will return the cores and provide test results to the Contractor.

4.9.3.3.2. **Segregation (Density Profile).** Test for segregation using density profiles in accordance with [Tex-207-F](#), Part V when using a thermal camera instead of the thermal imaging system. Density profiles are not required and are not applicable when using a thermal imaging system. Density profiles are not applicable in areas described in Section 3076.4.9.3.1.4., "Miscellaneous Areas."

Perform a minimum of one density profile per subplot. Perform additional density profiles when any of the following conditions occur, unless otherwise approved:

- the paver stops due to lack of material being delivered to the paving operations and the temperature of the uncompacted mat before the initial break down rolling is less than the temperatures shown in Table 17;
- areas that are identified by either the Contractor or the Engineer with thermal segregation,;
- any visibly segregated areas that exist.

Table 17
Minimum Uncompacted Mat Temperature Requiring a Segregation Profile

High-Temperature Binder Grade ¹	Minimum Temperature of the Uncompacted Mat Allowed Before Initial Break Down Rolling ^{2,3,4}
PG 64	<250°F
PG 70	<260°F
PG 76	<270°F

1. The high-temperature binder grade refers to the high-temperature grade of the virgin asphalt binder used to produce the mixture.
2. Segregation profiles are required in areas with moderate and severe thermal segregation as described in Section 3076.4.7.3.1.3.
3. Minimum uncompacted mat temperature requiring a segregation profile may be reduced 10°F if using a chemical WMA additive as a compaction aid.
4. When using WMA, the minimum uncompacted mat temperature requiring a segregation profile is 215°F.

Provide the Engineer with the density profile of every subplot in the lot within one working day of the completion of each lot. Report the results of each density profile in accordance with Section 3076.4.2., "Reporting and Responsibilities."

The density profile is considered failing if it exceeds the tolerances in Table 18. No production or placement payment adjustments greater than 1.000 will be paid for any subplot that contains a failing density profile. When a hand-held thermal camera is used instead of a thermal imaging system, the Engineer will measure the density profile at least once per project. The Engineer's density profile results will be used when available. The Engineer may require the Contractor to remove and replace the area in question if the area fails the density profile and has surface irregularities as defined in Section 3076.4.9.3.3.5., "Irregularities." The subplot in question may receive a production and placement payment adjustment greater than 1.000, if applicable, when the defective material is successfully removed and replaced.

Investigate density profile failures and take corrective actions during production and placement to eliminate the segregation. Suspend production if 2 consecutive density profiles fail unless otherwise approved. Resume production after the Engineer approves changes to production or placement methods.

Table 18
Segregation (Density Profile) Acceptance Criteria

Mixture Type	Maximum Allowable Density Range (Highest to Lowest)	Maximum Allowable Density Range (Average to Lowest)
Type B	8.0 pcf	5.0 pcf
Type C, Type D & Type F	6.0 pcf	3.0 pcf

4.9.3.3.3. Longitudinal Joint Density.

4.9.3.3.3.1. **Informational Tests.** Perform joint density evaluations while establishing the rolling pattern and verify that the joint density is no more than 3.0 pcf below the density taken at or near the center of the mat. Adjust the rolling pattern, if needed, to achieve the desired joint density. Perform additional joint density evaluations, at least once per subplot, unless otherwise directed.

4.9.3.3.3.2. **Record Tests.** Perform a joint density evaluation for each subplot at each pavement edge that is or will become a longitudinal joint. Joint density evaluations are not applicable in areas described in Section 3076.4.9.3.1.4., "Miscellaneous Areas." Determine the joint density in accordance with [Tex-207-F](#), Part VII. Record the joint density information and submit results on Department forms to the Engineer. The evaluation is considered failing if the joint density is more than 3.0 pcf below the density taken at the core random sample location and the correlated joint density is less than 90.0%. The Engineer will make independent joint density verification at least once per project and may make independent joint density verifications at the random sample locations. The Engineer's joint density test results will be used when available.

Provide the Engineer with the joint density of every subplot in the lot within one working day of the completion of each lot. Report the results of each joint density in accordance with Section 3076.4.2., "Reporting and Responsibilities."

Investigate joint density failures and take corrective actions during production and placement to improve the joint density. Suspend production if the evaluations on two consecutive sublots fail unless otherwise approved. Resume production after the Engineer approves changes to production or placement methods.

4.9.3.3.4. **Recovered Asphalt Dynamic Shear Rheometer (DSR).** The Engineer may take production samples or cores from suspect areas of the project to determine recovered asphalt properties. Asphalt binders with an aging ratio greater than 3.5 do not meet the requirements for recovered asphalt properties and may be deemed defective when tested and evaluated by the Materials and Tests Division. The aging ratio is the DSR value of the extracted binder divided by the DSR value of the original unaged binder. Obtain DSR values in accordance with AASHTO T 315 at the specified high temperature performance grade of the asphalt. The Engineer may require removal and replacement of the defective material at the Contractor's expense. The asphalt binder will be recovered for testing from production samples or cores in accordance with [Tex-211-F](#).

4.9.3.3.5. **Irregularities.** Identify and correct irregularities including segregation, rutting, raveling, flushing, fat spots, mat slippage, irregular color, irregular texture, roller marks, tears, gouges, streaks, uncoated aggregate particles, or broken aggregate particles. The Engineer may also identify irregularities, and in such cases, the Engineer will promptly notify the Contractor. If the Engineer determines that the irregularity will adversely affect pavement performance, the Engineer may require the Contractor to remove and replace (at the Contractor's expense) areas of the pavement that contain irregularities. The Engineer may also require the Contractor to remove and replace (at the Contractor's expense) areas where the mixture does not bond to the existing pavement.

If irregularities are detected, the Engineer may require the Contractor to immediately suspend operations or may allow the Contractor to continue operations for no more than one day while the Contractor is taking appropriate corrective action.

4.9.4. **Exempt Production.** The Engineer may deem the mixture as exempt production for the following conditions:

- anticipated daily production is less than 500 tons;
- total production for the project is less than 5,000 tons;
- when mutually agreed between the Engineer and the Contractor; or
- when shown on the plans.

For exempt production, the Contractor is relieved of all production and placement sampling and testing requirements, except for coring operations when required by the Engineer. The production and placement pay factors are 1.000 if the specification requirements listed below are met, all other specification requirements are met, and the Engineer performs acceptance tests for production and placement listed in Table 16 when 100 tons or more per day are produced.

- produce, haul, place, and compact the mixture in compliance with the specification and as directed;
- control mixture production to yield a laboratory-molded density that is within $\pm 1.0\%$ of the target laboratory-molded density as tested by the Engineer;
- compact the mixture in accordance with Section 3076.4.8., "Compaction;" and
- when a thermal imaging system is not used, the Engineer may perform segregation (density profiles) and thermal profiles in accordance with the specification.

4.9.5. **Ride Quality.** Measure ride quality in accordance with Item 585, "Ride Quality for Pavement Surfaces," unless otherwise shown on the plans.

5. MEASUREMENT

- 5.1. **Dense Graded Hot-Mix Asphalt.** Hot mix will be measured by the ton of composite hot-mix, which includes asphalt, aggregate, and additives. Measure the weight on scales in accordance with Item 520, "Weighing and Measuring Equipment."
- 5.2. **Tack Coat.** Tack coat will be measured at the applied temperature by strapping the tank before and after road application and determining the net volume in gallons from the calibrated distributor. The Engineer will witness all strapping operations for volume determination. All tack, including emulsions, will be measured by the gallon applied.

The Engineer may allow the use of a metering device to determine asphalt volume used and application rate if the device is accurate within 1.5% of the strapped volume.

6. PAYMENT

The work performed and materials furnished in accordance with this Item and measured as provided under Section 3076.5.1, "Measurement," will be paid for at the unit bid price for "Dense Graded Hot-Mix Asphalt" of the mixture type, SAC, and binder specified. These prices are full compensation for surface preparation, materials, placement, equipment, labor, tools, and incidentals.

The work performed and materials furnished in accordance with this Item and measured as provided under Article 3076.5.2, "Measurement," will be paid for at the unit bid price for "Tack Coat" of the tack coat provided. These prices are full compensation for materials, placement, equipment, labor, tools, and incidentals. Payment adjustments will be applied as determined in this Item; however, a payment adjustment factor of 1.000 will be assigned for all placement sublots for "level ups" only when "level up" is listed as part of the item bid description code. A payment adjustment factor of 1.000 will be assigned to all production and placement sublots when "exempt" is listed as part of the item bid description code, and all testing requirements are met.

Payment for each subplot, including applicable payment adjustments greater than 1.000, will only be paid for sublots when the Contractor supplies the Engineer with the required documentation for production and placement QC/QA, thermal profiles, segregation density profiles, and longitudinal joint densities in accordance with Section 3076.4.2., "Reporting and Responsibilities." When a thermal imaging system is used, documentation is not required for thermal profiles or segregation density profiles on individual sublots; however, the thermal imaging system automated reports described in [Tex-244-F](#) are required.

Trial batches will not be paid for unless they are included in pavement work approved by the Department.

Payment adjustment for ride quality will be determined in accordance with Item 585, "Ride Quality for Pavement Surfaces."

- 6.1. **Production Payment Adjustment Factors.** The production payment adjustment factor is based on the laboratory-molded density using the Engineer's test results. The bulk specific gravities of the samples from each subplot will be divided by the Engineer's maximum theoretical specific gravity for the subplot. The individual sample densities for the subplot will be averaged to determine the production payment adjustment factor in accordance with Table 19 for each subplot, using the deviation from the target laboratory-molded density defined in Table 9. The production payment adjustment factor for completed lots will be the average of the payment adjustment factors for the four sublots sampled within that lot.

Table 19
Production Payment Adjustment Factors for Laboratory-Molded Density¹

Absolute Deviation from Target Laboratory-Molded Density	Production Payment Adjustment Factor (Target Laboratory-Molded Density)
0.0	1.050
0.1	1.050
0.2	1.050
0.3	1.044
0.4	1.038
0.5	1.031
0.6	1.025
0.7	1.019
0.8	1.013
0.9	1.006
1.0	1.000
1.1	0.965
1.2	0.930
1.3	0.895
1.4	0.860
1.5	0.825
1.6	0.790
1.7	0.755
1.8	0.720
> 1.8	Remove and replace

1. If the Engineer's laboratory-molded density on any subplot is less than 95.0% or greater than 98.0%, take immediate corrective action to bring the mixture within these tolerances. The Engineer may suspend operations if the Contractor's corrective actions do not produce acceptable results. The Engineer will allow production to resume when the proposed corrective action is likely to yield acceptable results.

6.1.1. **Payment for Incomplete Production Lots.** Production payment adjustments for incomplete lots, described under Section 3076.4.9.2.1.1., "Incomplete Production Lots," will be calculated using the average production payment factors from all sublots sampled.

A production payment factor of 1.000 will be assigned to any lot when the random sampling plan did not result in collection of any samples within the first subplot.

6.1.2. **Production Sublots Subject to Removal and Replacement.** If after referee testing, the laboratory-molded density for any subplot results in a "remove and replace" condition as listed in Table 19, the Engineer may require removal and replacement or may allow the subplot to be left in place without payment. The Engineer may also accept the subplot in accordance with Section 3076.5.3.1., "Acceptance of Defective or Unauthorized Work." Replacement material meeting the requirements of this Item will be paid for in accordance with this Section.

6.2. **Placement Payment Adjustment Factors.** The placement payment adjustment factor is based on in-place air voids using the Engineer's test results. The bulk specific gravities of the cores from each subplot will be divided by the Engineer's average maximum theoretical specific gravity for the lot. The individual core densities for the subplot will be averaged to determine the placement payment adjustment factor in accordance with Table 20 for each subplot that requires in-place air void measurement. A placement payment adjustment factor of 1.000 will be assigned to the entire subplot when the random sample location falls in an area designated on the plans as not subject to in-place air void determination. A placement payment adjustment factor of 1.000 will be assigned to quantities placed in areas described in Section 3076.4.9.3.1.4., "Miscellaneous Areas." The placement payment adjustment factor for completed lots will be the average of the placement payment adjustment factors for up to four sublots within that lot.

Table 20
Placement Payment Adjustment Factors for In-Place Air Voids

In-Place Air Voids	Placement Pay Adjustment Factor	In-Place Air Voids	Placement Pay Adjustment Factor
< 2.7	Remove and Replace	6.4	1.042
2.7	0.710	6.5	1.040
2.8	0.740	6.6	1.038
2.9	0.770	6.7	1.036
3.0	0.800	6.8	1.034
3.1	0.830	6.9	1.032
3.2	0.860	7.0	1.030
3.3	0.890	7.1	1.028
3.4	0.920	7.2	1.026
3.5	0.950	7.3	1.024
3.6	0.980	7.4	1.022
3.7	0.998	7.5	1.020
3.8	1.002	7.6	1.018
3.9	1.006	7.7	1.016
4.0	1.010	7.8	1.014
4.1	1.014	7.9	1.012
4.2	1.018	8.0	1.010
4.3	1.022	8.1	1.008
4.4	1.026	8.2	1.006
4.5	1.030	8.3	1.004
4.6	1.034	8.4	1.002
4.7	1.038	8.5	1.000
4.8	1.042	8.6	0.998
4.9	1.046	8.7	0.996
5.0	1.050	8.8	0.994
5.1	1.050	8.9	0.992
5.2	1.050	9.0	0.990
5.3	1.050	9.1	0.960
5.4	1.050	9.2	0.930
5.5	1.050	9.3	0.900
5.6	1.050	9.4	0.870
5.7	1.050	9.5	0.840
5.8	1.050	9.6	0.810
5.9	1.050	9.7	0.780
6.0	1.050	9.8	0.750
6.1	1.048	9.9	0.720
6.2	1.046	> 9.9	Remove and Replace
6.3	1.044		

6.2.1.

Payment for Incomplete Placement Lots. Payment adjustments for incomplete placement lots described under Section 3076.4.9.3.1.2., "Incomplete Placement Lots," will be calculated using the average of the placement payment factors from all sublots sampled and sublots where the random location falls in an area designated on the plans as not eligible for in-place air void determination.

If the random sampling plan results in production samples, but not in placement samples, the random core location and placement adjustment factor for the subplot will be determined by applying the placement random number to the length of the subplot placed.

If the random sampling plan results in placement samples, but not in production samples, no placement adjustment factor will apply for that subplot placed.

A placement payment adjustment factor of 1.000 will be assigned to any lot when the random sampling plan did not result in collection of any production samples.

- 6.2.2. **Placement Sublots Subject to Removal and Replacement.** If after referee testing, the placement payment adjustment factor for any subplot results in a “remove and replace” condition as listed in Table 20, the Engineer will choose the location of two cores to be taken within 3 ft. of the original failing core location. The Contractor will obtain the cores in the presence of the Engineer. The Engineer will take immediate possession of the untrimmed cores and submit the untrimmed cores to the Materials and Tests Division, where they will be trimmed if necessary and tested for bulk specific gravity within 10 working days of receipt.

The bulk specific gravity of the cores from each subplot will be divided by the Engineer’s average maximum theoretical specific gravity for the lot. The individual core densities for the subplot will be averaged to determine the new payment adjustment factor of the subplot in question. If the new payment adjustment factor is 0.700 or greater, the new payment adjustment factor will apply to that subplot. If the new payment adjustment factor is less than 0.700, no payment will be made for the subplot. Remove and replace the failing subplot, or the Engineer may allow the subplot to be left in place without payment. The Engineer may also accept the subplot in accordance with Section 3076.5.3.1., “Acceptance of Defective or Unauthorized Work.” Replacement material meeting the requirements of this Item will be paid for in accordance with this Section.

- 6.3. **Total Adjusted Pay Calculation.** Total adjusted pay (TAP) will be based on the applicable payment adjustment factors for production and placement for each lot.

$$TAP = (A+B)/2$$

where:

A = Bid price × production lot quantity × average payment adjustment factor for the production lot

B = Bid price × placement lot quantity × average payment adjustment factor for the placement lot + (bid price × quantity placed in miscellaneous areas × 1.000)

Production lot quantity = Quantity actually placed - quantity left in place without payment

Placement lot quantity = Quantity actually placed - quantity left in place without payment - quantity placed in miscellaneous areas

Special Specification 3079

Permeable Friction Course



1. DESCRIPTION

Construct a hot-mix asphalt (HMA) surface course composed of a compacted permeable mixture of aggregate, asphalt binder, and additives mixed hot in a mixing plant.

2. MATERIALS

Furnish uncontaminated materials of uniform quality that meet the requirements of the plans and specifications.

Notify the Engineer of all material sources and before changing any material source or formulation. The Engineer will verify that the specification requirements are met when the Contractor makes a source or formulation change, and may require a new laboratory mixture design, trial batch, or both. The Engineer may sample and test project materials at any time during the project to verify specification compliance in accordance with Item 6, “**Control of Materials.**”

- 2.1. Aggregate. Furnish aggregates from sources that conform to the requirements in accordance with Table 1 and as specified in this Section. Aggregate requirements in this Section, including those shown in Table 1, may be modified or eliminated when shown on the plans. Additional aggregate requirements may be specified when shown on the plans. Provide aggregate stockpiles that meet the definitions in this Section for coarse aggregate. Do not use intermediate or fine aggregate in permeable friction course (PFC) mixtures. Supply aggregates that meet the definitions in [Tex-100-E](#) for crushed gravel or crushed stone. The Engineer will designate the plant or the quarry as the sampling location. Provide samples from materials produced for the project. The Engineer will establish the Surface Aggregate Classification (SAC) and perform Los Angeles abrasion, magnesium sulfate soundness, and Micro-Deval tests. Perform all other aggregate quality tests in accordance with Table 1. Document all test results on the mixture design report. The Engineer may perform tests on independent or split samples to verify Contractor test results. Stockpile aggregates for each source and type separately. Determine aggregate gradations for mixture design and production testing based on the washed sieve analysis given in [Tex-200-F](#), Part II.

- 2.1.1. Coarse Aggregate. Coarse aggregate stockpiles must have no more than 20% material passing the No. 8 sieve. Aggregates from sources listed in the **Department's Bituminous Rated Source Quality Catalog (BRSQC)** are preapproved for use. Use only the rated values for hot-mix listed in the BRSQC. Rated values for surface treatment (ST) do not apply to coarse aggregate sources used in hot-mix asphalt.

For sources not listed on the **Department's BRSQC**:

- build an individual stockpile for each material;
- request the Department test the stockpile for specification compliance;
- approved only when tested by the Engineer;
- once approved, do not add material to the stockpile unless otherwise approved; and
- allow 30 calendar days for the Engineer to sample, test, and report results.

Provide coarse aggregate with at least the minimum SAC shown on the plans. SAC requirements only apply to aggregates used on the surface of travel lanes, unless otherwise shown on the plans. SAC requirements apply to aggregates used on surfaces other than travel lanes when shown on the plans. The SAC for sources on the **Department's Aggregate Quality Monitoring Program (AQMP)** ([Tex-499-A](#)) is listed in the BRSQC.

2.1.1.1. Blending Class A and Class B Aggregates. To prevent crushing of the Class B aggregate when blending, Class B aggregate may be blended with a Class A aggregate to meet requirements for Class A materials if the **Department's** BRSOC rated source soundness magnesium (RSSM) rating for the Class B aggregate is less than the Class A aggregate or if the RSSM rating for the Class B aggregate is less than or equal to 10%. Use the rated values for hot mix asphaltic concrete (HMAC) published in the BRSOC. When blending Class A and B aggregates to meet a Class A requirement, ensure that at least 50% by weight, or volume if required, of all the aggregates used in the mixture design retained on the No. 4 sieve comes from the Class A aggregate source, unless otherwise shown on the plans. Blend by volume if the bulk specific gravities of the Class A and B aggregates differ by more than 0.300. Class B aggregate may be disallowed when shown on the plans.

The Engineer may perform tests at any time during production, when the Contractor blends Class A and B aggregates to meet a Class A requirement, to ensure that at least 50% by weight, or volume if required, of the material retained on the No. 4 sieve comes from the Class A aggregate source. The Engineer will use the **Department's** mix design template, when electing to verify conformance, to calculate the percent of Class A aggregate retained on the No. 4 sieve by inputting the bin percentages shown from readouts in the control room at the time of production and stockpile gradations measured at the time of production. The Engineer may determine the gradations based on either washed or dry sieve analysis from samples obtained from individual aggregate cold feed bins or aggregate stockpiles. The Engineer may perform spot checks using the gradations supplied by the Contractor on the mixture design report as an input for the template; however, a failing spot check will require confirmation with a stockpile gradation determined by the Engineer.

2.1.1.2. Micro-Deval Abrasion. The Engineer will perform a minimum of one Micro-Deval abrasion test in accordance with [Tex-461-A](#) for each coarse aggregate source used in the mixture design that has a Rated Source Soundness Magnesium (RSSM) loss value greater than 10 as listed in the BRSOC, unless otherwise directed. The Engineer will perform testing before the start of production and may perform additional testing at any time during production. The Engineer may obtain the coarse aggregate samples from each coarse aggregate source or may require the Contractor to obtain the samples. The Engineer may waive all Micro-Deval testing based on a satisfactory test history of the same aggregate source.

The Engineer will estimate the magnesium sulfate soundness loss for each coarse aggregate source, when tested, using the following formula:

$$Mg_{est.} = (RSSM)(MD_{act.}/RSMD)$$

where:

$Mg_{est.}$ = magnesium sulfate soundness loss

RSSM = Rated Source Soundness Magnesium

$MD_{act.}$ = actual Micro-Deval percent loss

RSMD = Rated Source Micro-Deval

When the estimated magnesium sulfate soundness loss is greater than the maximum magnesium sulfate soundness loss specified, the coarse aggregate source will not be allowed for use unless otherwise approved. The Engineer will consult the Soils and Aggregates Section of the Materials and Tests Division, and additional testing may be required before granting approval.

Table 1
Coarse Aggregate Quality Requirements

Property	Test Method	Requirement
SAC	Tex-499-A (AQMP)	As shown on the plans
Deleterious material, %, Max	Tex-217-F , Part I	1.0
Decantation, %, Max	Tex-217-F , Part II	1.5
Micro-Deval abrasion, %	Tex-461-A	Note ¹
Los Angeles abrasion, %, Max	Tex-410-A	30
Magnesium sulfate soundness, 5 cycles, %, Max	Tex-411-A	20
Crushed face count, ² %, Min	Tex-460-A , Part I	95
Flat and elongated particles @ 5:1, %, Max	Tex-280-F	10

1. Used to estimate the magnesium sulfate soundness loss in accordance with Section 3079.2.1.1.2., "**Micro-Deval Abrasion.**"

2. Only applies to crushed gravel.

- 2.2. Baghouse Fines. Fines collected by the baghouse or other dust-collecting equipment may be reintroduced into the mixing drum.
- 2.3. Asphalt Binder. Furnish the type and grade of binder specified on the plans that meets the requirements of Item 300, "**Asphalts, Oils, and Emulsions.**"
- 2.3.1. Performance-Graded (PG) Binder. Provide an asphalt binder with a high-temperature grade of PG 76 and low-temperature grade as shown on the plans in accordance with Section 300.2.10., "**Performance-Graded Binders,**" when PG binder is specified.
- 2.3.2. Asphalt-Rubber (A-R) Binder. Provide A-R binder that meets the Type I or Type II requirements of Section 300.2.9., "**Asphalt-Rubber Binders,**" when A-R is specified unless otherwise shown on the plans. Use at least 15.0% by weight of Crumb Rubber Modifier (CRM) that meets the Grade B or Grade C requirements of Section 300.2.7., "**Crumb Rubber Modifier,**" unless otherwise shown on the plans. Provide the Engineer the A-R binder blend design with the mix design (JMF1) submittal. Provide the Engineer with documentation such as the bill of lading showing the quantity of CRM used in the project unless otherwise directed.
- 2.4. Tack Coat. Furnish CSS-1H, SS-1H, EBL, or a PG binder with a minimum high-temperature grade of PG 58 for tack coat binder in accordance with Item 300, "**Asphalts, Oils, and Emulsions.**" Specialized tack coat materials listed on the Department's **Tracking Resistant Asphalt Interlayer (TRAIL) MPL** may be allowed or required when shown on the plans. Do not dilute emulsified asphalts at the terminal, in the field, or at any other location before use.
- 2.5. Additives. Provide the Engineer with documentation such as the bill of lading showing the quantity of additives used in the project unless otherwise directed.
- 2.5.1. Fibers. Provide cellulose or mineral fibers when PG binder is specified. Do not use fibers when A-R binder is specified. Submit written certification to the Engineer that the fibers proposed for use meet the requirements of DMS-9204, "**Fiber Additives for Bituminous Mixtures.**" Fibers may be pre-blended into the binder at the asphalt supply terminal unless otherwise shown on the plans.
- 2.5.2. Lime Mineral Filler. Add lime as mineral filler at a rate of 1.0% by weight of the total dry aggregate in accordance with Item 301, "**Asphalt Antistripping Agents,**" unless otherwise shown on the plans or waived by the Engineer based on Hamburg Wheel test results. Do not add lime directly into the mixing drum of any plant where lime is removed through the exhaust stream unless the plant has a baghouse or dust collection system that reintroduces the lime into the drum.
- 2.5.3. Lime and Liquid Antistripping Agent. When lime or a liquid antistripping agent is used, add in accordance with Item 301, "**Asphalt Antistripping Agents.**" Do not add lime directly into the mixing drum of any plant where lime is removed through the exhaust stream unless the plant has a baghouse or dust collection system that reintroduces the lime into the drum. When the plans require lime to be added as an antistripping agent, lime added as mineral filler will count towards the total quantity of lime specified.
- 2.5.4. Compaction Aid. Compaction aid is defined as a Department-approved chemical warm mix additive denoted as "chemical additive" on the Department's **materials producer list (MPL)** that is used to facilitate mixing and compaction of HMA.
- Compaction aid is allowed for use on all projects. Compaction aid is required when shown on the plans or as required in Section 3079.4.7.1., "**Weather Conditions.**"
- Warm mix foaming processes, denoted as "foaming process" on the Department-approved MPL, may be used to facilitate mixing and compaction of HMA; however warm mix foaming processes are not defined as a Compaction aid.
- 2.6. Recycled Materials. Recycled materials are not allowed for use.

3. EQUIPMENT

Provide required or necessary equipment in accordance with Item 320, "**Equipment for Asphalt Concrete Pavement.**" When A-R binder is specified, equip the hot-mix plant with an in-line viscosity-measuring device located between the blending unit and the mixing drum. Provide a means to calibrate the asphalt mass flow meter on-site when a meter is used.

4. CONSTRUCTION

Produce, haul, place, and compact the specified paving mixture. In addition to tests required by the specification, Contractors may perform other QC tests as deemed necessary. At any time during the project, the Engineer may perform production and placement tests as deemed necessary in accordance with Item 5, "**Control of the Work.**" Schedule and participate in a mandatory pre-paving meeting with the Engineer on or before the first day of paving unless otherwise shown on the plans.

- 4.1. Certification. Personnel certified by the Department-approved hot-mix asphalt certification program must conduct all mixture designs, sampling, and testing in accordance with Table 2. Supply the Engineer with a list of certified personnel and copies of their current certificates before beginning production and when personnel changes are made. Provide a mixture design developed and signed by a Level 2 certified specialist. Provide Level 1A certified specialists at the plant during production operations. Provide Level 1B certified specialists to conduct placement tests. Provide Level AGG101 certified specialists for aggregate testing.

Table 2
Test Methods, Test Responsibility, and Minimum Certification Levels

Test Description	Test Method	Contractor	Engineer	Level ¹
<i>1. Aggregate Testing</i>				
Sampling	Tex-221-F	✓	✓	1A/AGG101
Dry sieve	Tex-200-F, Part I	✓	✓	1A/AGG101
Washed sieve	Tex-200-F, Part II	✓	✓	1A/AGG101
Deleterious material	Tex-217-F, Parts I & III	✓	✓	AGG101
Decantation	Tex-217-F, Part II	✓	✓	AGG101
Los Angeles abrasion	Tex-410-A		✓	Department
Magnesium sulfate soundness	Tex-411-A		✓	Department
Micro-Deval abrasion	Tex-461-A		✓	AGG101
Crushed face count	Tex-460-A	✓	✓	AGG101
Flat and elongated particles	Tex-280-F	✓	✓	AGG101
<i>2. Asphalt Binder & Tack Coat Sampling</i>				
Asphalt binder sampling	Tex-500-C, Part II	✓	✓	1A/1B
Tack coat sampling	Tex-500-C, Part III	✓	✓	1A/1B
<i>3. Mix Design & Verification</i>				
Design and JMF changes	Tex-204-F	✓	✓	2
Mixing	Tex-205-F	✓	✓	2
Molding (SGC)	Tex-241-F	✓	✓	1A
Laboratory-molded density	Tex-207-F, Parts I, VI, & VIII	✓	✓	1A
Rice gravity	Tex-227-F, Part II	✓	✓	1A
Ignition oven correction factors ²	Tex-236-F, Part II	✓	✓	2
Drain-down	Tex-235-F	✓	✓	1A
Hamburg Wheel test	Tex-242-F	✓	✓	1A
Boil test ⁴	Tex-530-C	✓	✓	1A
Cantabro loss	Tex-245-F	✓	✓	1A
<i>4. Production Testing</i>				
Control charts	Tex-233-F	✓	✓	1A
Mixture sampling	Tex-222-F	✓	✓	1A/1B
Gradation & asphalt binder content ²	Tex-236-F, Part I	✓	✓	1A
Moisture content	Tex-212-F, Part II	✓	✓	1A/AGG101
Micro-Deval abrasion	Tex-461-A		✓	AGG101
Drain-down	Tex-235-F	✓	✓	1A
Boil test ⁴	Tex-530-C	✓	✓	1A
Abson recovery	Tex-211-F		✓	Department
<i>5. Placement Testing</i>				
Control charts	Tex-233-F	✓	✓	1A
Ride quality measurement	Tex-1001-S	✓	✓	Note 3
Thermal profile	Tex-244-F	✓	✓	1B
Water flow test	Tex-246-F	✓	✓	1B
Shear bond strength test	Tex-249-F		✓	Department

1. Level 1A, 1B, AGG101, and 2 are certification levels provided by the Hot Mix Asphalt Center certification program.
2. Refer to Section 3079.4.9.2.3., "Production Testing," for exceptions to using an ignition oven.
3. Profiler and operator are required to be certified at the Texas A&M Transportation Institute facility when Surface Test Type B is specified.
4. When shown on the plans.

- 4.2. Reporting and Responsibilities. Use Department-provided templates to record and calculate all test data, including mixture design, production and placement tests, control charts, and thermal profiles. Obtain the current version of the templates at <https://www.txdot.gov/inside-txdot/forms-publications/consultants-contractors/forms/site-manager.html> or from the Engineer. The Engineer and the Contractor will provide any available test results to the other party when requested. The maximum allowable time for the Contractor and Engineer to exchange test data is given in Table 3. The Engineer and the Contractor will immediately report to the other party any test result that requires suspension of production or placement or that fails to meet the specification requirements. Record and electronically submit all test results and pertinent information on Department-provided templates.

Subsequent sublots placed after test results are available to the Contractor, which require suspension of operations, may be considered unauthorized work. Unauthorized work will be accepted or rejected at the discretion of the Engineer in accordance with Article 5.3., **“Conformity with Plans, Specifications, and Special Provisions.”**

Table 3
Reporting Schedule

Description	Reported By	Reported To	To Be Reported Within
<i>Production Quality Control</i>			
Gradation ¹	Contractor	Engineer	1 working day of completion of the subplot
Asphalt binder content ¹			
Laboratory-molded density ¹			
Moisture content ²			
Drain-down ¹			
Boil test ⁴			
<i>Production Quality Assurance</i>			
Gradation ²	Engineer	Contractor	1 working day of completion of the subplot
Asphalt binder content ²			
Laboratory-molded density ²			
Hamburg Wheel test ³			
Boil test ⁴			
Drain-down ²			
Binder tests ³			
<i>Placement Quality Control</i>			
Thermal profile ¹	Contractor	Engineer	1 working day of completion of the lot
Water flow ¹			
<i>Placement Quality Assurance</i>			
Thermal profile ²	Engineer	Contractor	1 working day of completion of the lot
Aging ratio ³			
Water flow ²			

1. These tests are required on every subplot.
2. To be performed at the frequency in accordance with Table 9 or as shown on the plans.
3. To be reported as soon as the results become available.
4. When shown on the plans

Use the procedures described in [Tex-233-F](#) to plot the results of all production and placement testing, when directed. Update the control charts as soon as test results for each subplot become available. Make the control charts readily accessible at the field laboratory. The Engineer may suspend production for failure to update control charts.

- 4.3. Quality Control Plan (QCP). Develop and follow the QCP in detail. Obtain approval for changes to the QCP made during the project. The Engineer may suspend operations if the Contractor fails to comply with the QCP.

Submit a written QCP before the mandatory pre-paving meeting when directed. Receive approval of the QCP before pre-paving meeting. Include the following items in the QCP:

- 4.3.1. Project Personnel. For project personnel, include:
- a list of individuals responsible for QC with authority to take corrective action;
 - current contact information for each individual listed; and

- current copies of certification documents for individuals performing specified QC functions.

4.3.2. Material Delivery and Storage. For material delivery and storage, include:

- the sequence of material processing, delivery, and minimum quantities to assure continuous plant operations;
- aggregate stockpiling procedures to avoid contamination and segregation;
- frequency, type, and timing of aggregate stockpile testing to assure conformance of material requirements before mixture production; and
- procedure for monitoring the quality and variability of asphalt binder.

4.3.3. Production. For production, include:

- loader operation procedures to avoid contamination in cold bins;
- procedures for calibrating and controlling cold feeds;
- procedures to eliminate debris or oversized material;
- procedures for adding and verifying rates of each applicable mixture component (e.g., aggregate, asphalt binder, lime, liquid antistripping, compaction aid, foaming process, fibers);
- procedures for reporting job control test results; and
- procedures to avoid segregation and drain-down in the silo.

4.3.4. Loading and Transporting. For loading and transporting, include:

- type and application method for release agents; and
- truck loading procedures to avoid segregation.

4.3.5. Placement and Compaction. For placement and compaction, include:

- proposed agenda for mandatory pre-paving meeting, including date and location;
- proposed paving plan (e.g., production rate, paving widths, joint offsets, and lift thicknesses);
- type and application method for release agents in the paver and on rollers, shovels, lutes, and other utensils;
- procedures for the transfer of mixture into the paver, while avoiding physical and thermal segregation and preventing material spillage;
- process to balance production, delivery, paving, and compaction to achieve continuous placement operations and good ride quality;
- paver operations (e.g., speed, operation of wings, height of mixture in auger chamber) to avoid physical and thermal segregation and other surface irregularities; and
- procedures to construct quality longitudinal and transverse joints.

4.4. Mixture Design.

4.4.1. Design Requirements. Use the PFC design procedure provided in [Tex-204-E](#), unless otherwise shown on the plans. Design the mixture to meet the requirements in accordance with Tables 1, 4, 5, and 6. Use a Superpave Gyrotory Compactor (SGC) at 50 gyrations as the design number of gyrations (N_{design}).

The Engineer will provide the mixture design when shown on the plans. The Contractor may submit a new mixture design at any time during the project. The Engineer will verify and approve all mixture designs (JMF1) before the Contractor can begin production.

Provide the Engineer with a mixture design report using the Department-provided template. Include the following items in the report:

- the combined aggregate gradation, source, specific gravity, and percent of each material used;
- results of all applicable tests;
- the mixing and molding temperatures;
- the signature of the Level 2 person or persons that performed the design;

- the date the mixture design was performed; and
- a unique identification number for the mixture design.

Table 4
Master Gradation Limits (% Passing by Weight or Volume)

Sieve Size	PG 76 Mixtures		A-R Mixtures		Test Procedure
	Fine (PFC-F)	Coarse (PFC-C)	Fine (PFCR-F)	Coarse (PFCR-C)	
3/4"	–	100.0 ¹	100.0 ¹	100.0 ¹	Tex-200-F
1/2"	100.0 ¹	80.0–100.0	95.0–100.0	80.0–100.0	
3/8"	95.0–100.0	35.0–60.0	50.0–80.0	35.0–60.0	
#4	20.0–55.0	1.0–20.0	0.0–8.0	0.0–20.0	
#8	1.0–10.0	1.0–10.0	0.0–4.0	0.0–10.0	
#200	1.0–4.0	1.0–4.0	0.0–4.0	0.0–4.0	

1. Defined as maximum sieve size. No tolerance allowed.

Table 5
Mixture Design Properties

Mix Property	PG 76 Mixtures		A-R Mixtures		Test Procedure
	Fine (PFC-F) Requirements	Coarse (PFC-C) Requirements	Fine (PFCR-F) Requirements	Coarse (PFCR-C) Requirements	
Design gyrations (N _{design})	50	50	50	50	Tex-241-F
Lab-molded density, %	78.0 Max	82.0 Max	82.0 Max	82.0 Max	Tex-207-F
Asphalt Binder Content, %	6.0–7.0	6.0–7.0	8.0–10.0	7.0–9.0	--
Hamburg Wheel test, ¹ passes at 12.5 mm rut depth	10,000 Min ²	Note 3	Note 3	Note 3	Tex-242-F
Drain-down, %	0.10 Max	0.10 Max	0.10 Max	0.10 Max	Tex-235-F
Fiber content, % by wt. of total PG 76 mixture	0.20–0.50	0.20–0.50	–	–	Calculated
Lime content, % by wt. of total aggregate	1.0 ⁴	1.0 ⁴	–	–	Calculated
CRM content, % by wt. of A-R binder	–	–	15.0 Min	15.0 Min	Calculated
Boil test ⁵	–	–	–	–	Tex-530-C
Cantabro loss, %	20.0 Max	20.0 Max	20.0 Max	20.0 Max	Tex-245-F

1. Mold test specimens to N_{design} at the optimum asphalt binder content.
2. May be decreased when shown on the plans.
3. No specification value is required unless otherwise shown on the plans.
4. Unless otherwise shown on the plans or waived by the Engineer based on Hamburg Wheel results.
5. When shown on the plans. Used to establish baseline for comparison to production results.

4.4.2. Job-Mix Formula Approval. The job-mix formula (JMF) is the combined aggregate gradation, N_{design} level, and target asphalt percentage used to establish target values for hot-mix production. JMF1 is the original laboratory mixture design used to produce the trial batch. When a compaction aid or foaming process is used, JMF1 may be designed and submitted to the Engineer without including the compaction aid or foaming process. When a compaction aid or foaming process is used, document the compaction aid or foaming process used and recommended rate on the JMF1 submittal. The Engineer and the Contractor will verify JMF1 based on plant-produced mixture from the trial batch unless otherwise approved. The Engineer may accept an existing mixture design previously used on a Department project and may waive the trial batch to verify JMF1. The Department may require the Contractor to reimburse the Department for verification tests if more than two trial batches per design are required.

4.4.2.1. **Contractor's** Responsibilities.

- 4.4.2.1.1. Providing Gyratory Compactor. Furnish an SGC calibrated in accordance with [Tex-241-F](#) for molding production samples. Locate the SGC at the **Engineer's** field laboratory or make the SGC available to the Engineer for use in molding production samples.
- 4.4.2.1.2. Gyratory Compactor Correlation Factors. Use [Tex-206-F](#), Part II, to perform a gyratory compactor correlation when the Engineer uses a different SGC. Apply the correlation factor to all subsequent production test results.
- 4.4.2.1.3. Submitting JMF1. Furnish a mix design report (JMF1) with representative samples of all component materials and request approval to produce the trial batch. Provide an additional 25 lb. of the design mixture if opting to have the Department perform the Hamburg Wheel test on the laboratory mixture when required in accordance with Table 5, and request that the Department perform the test.
- 4.4.2.1.4. Supplying Aggregates. Provide approximately 40 lb. of each aggregate stockpile unless otherwise directed.
- 4.4.2.1.5. Supplying Asphalt. Provide at least 1 gal. of the asphalt material and enough quantities of any additives proposed for use.
- 4.4.2.1.6. Ignition Oven Correction Factors. Determine the aggregate and asphalt correction factors from the ignition oven in accordance with [Tex-236-F](#), Part II. Provide correction factors that are not more than 12 mo. old. Note that the asphalt content correction factor takes into account the percent fibers in the mixture so that the fibers are excluded from the binder content determination. Provide the Engineer with split samples of the mixtures before the trial batch production, including all additives (except water), and blank samples used to determine the correction factors for the ignition oven used for quality assurance (QA) testing during production. Correction factors established from a previously approved mixture design may be used for the current mixture design if the mixture design and ignition oven are the same as previously used and the correction factors are not more than 12 mo. old, unless otherwise directed.
- 4.4.2.1.7. Boil Test. When shown on the plans, perform the test and retain the tested sample from [Tex-530-C](#) until completion of the project or as directed. Use this sample for comparison purposes during production. Add lime or liquid antistripping agent, as directed, if signs of stripping exist.
- 4.4.2.1.8. Trial Batch Production. Provide a plant-produced trial batch upon receiving conditional approval of JMF1 and authorization to produce a trial batch including the compaction aid or foaming process, if applicable, for verification testing of JMF1 and development of JMF2. Produce a trial batch mixture that meets the requirements in accordance with Table 6. The Engineer may accept test results from recent production of the same mixture instead of a new trial batch.
- 4.4.2.1.9. Trial Batch Production Equipment. Use only equipment and materials proposed for use on the project to produce the trial batch. Provide documentation to verify the calibration or accuracy of the asphalt mass flow meter to measure the binder content. Verify that asphalt mass flow meter meets the requirements of 0.4% accuracy, when required, in accordance with Item 520, "**Weighing and Measuring Equipment.**" The Engineer may require that the accuracy of the mass flow meter be verified based on quantities used.
- 4.4.2.1.10. Trial Batch Quantity. Produce enough quantity of the trial batch to ensure that the mixture meets the specification requirements.
- 4.4.2.1.11. Number of Trial Batches. Produce trial batches as necessary to obtain a mixture that meets the specification requirements.
- 4.4.2.1.12. Trial Batch Sampling. Obtain a representative sample of the trial batch and split it into three equal portions in accordance with [Tex-222-F](#). Label these portions as "**Contractor,**" "**Engineer,**" and "**Referee.**" Deliver samples to the appropriate laboratory as directed.
- 4.4.2.1.13. Trial Batch Testing. Test the trial batch to ensure the mixture produced using the proposed JMF1 meets the mixture requirements in accordance with Table 6. Ensure the trial batch mixture is also in compliance with the requirements in accordance with Table 5. Use a Department-approved laboratory listed on the MPL to perform

the Hamburg Wheel test on the trial batch mixture or request that the Department perform the Hamburg Wheel test. Provide an additional 25 lb. of the trial batch mixture if opting to have the Department perform the Hamburg Wheel test, if applicable, and request that the Department perform the test. The Engineer will be allowed 10 working days to provide the Contractor with Hamburg Wheel test results on the trial batch. Provide the Engineer with a copy of the trial batch test results.

- 4.4.2.1.14. Development of JMF2. Evaluate the trial batch test results, determine the target mixture proportions, and submit as JMF2 after the Engineer grants full approval of JMF1 based on results from the trial batch. The mixture produced using JMF2 must meet the requirements in accordance with Tables 4 and 5. Verify that JMF2 meets the operational tolerances in accordance with Table 6.
- 4.4.2.1.15. Mixture Production. Use JMF2 to produce Lot 1 after receiving approval for JMF2.
- 4.4.2.1.16. Development of JMF3. Evaluate the test results from Lot 1, determine the optimum mixture proportions, and submit as JMF3 for use in Lot 2.
- 4.4.2.1.17. JMF Adjustments. If JMF adjustments are necessary to achieve the specified requirements, make the adjustments before beginning a new lot. The adjusted JMF must:
- be provided to the Engineer in writing before the start of a new lot;
 - be numbered in sequence to the previous JMF;
 - meet the master gradation limits in accordance with Table 4; and
 - be within the operational tolerances of JMF2 in accordance with Table 6.
- 4.4.2.1.18. Requesting Referee Testing. Use referee testing, if needed, in accordance with Section 3079.4.9.1., "Referee **Testing**," to resolve testing differences with the Engineer.

Table 6
Operational Tolerances

Test Description	Test Method	Allowable Difference between JMF2 and JMF1 Target ¹	Allowable Difference from Current JMF and JMF2 ²	Allowable Difference between Contractor and Engineer ³
Individual % retained for sieve sized larger than #200	Tex-200-F	Must be Within Master Grading Limits in accordance with Table 4	±3.0 ⁴	±5.0 ⁴
% passing the #200 sieve				±2.0 ⁴
Laboratory-molded density, %	Tex-207-F , Part VIII	±1.0	±1.0	±1.0
Asphalt binder content, %	Tex-236-F , Part I ⁵	±0.3 ^{6,7}	±0.3 ^{4,6,7}	±0.3 ^{6,7}
Drain-down, %	Tex-235-F	Note 8	Note 8	N/A
Boil test	Tex-530-C	Note 9	Note 9	N/A

1. JMF1 is the approved laboratory mixture design used for producing the trial batch. JMF2 is the approved mixture design developed from the trial batch used to produce Lot 1.
2. Current JMF is JMF3 or higher. JMF3 is the approved mixture design used to produce Lot 2.
3. Contractor may request referee testing only when values exceed these tolerances.
4. Only applies to mixture produced for Lot 1 and higher. Aggregate gradation is not allowed to be outside the limits shown in Table 4.
5. Ensure the binder content determination excludes fibers.
6. May be obtained from asphalt mass flow meter readouts as determined by the Engineer.
7. Binder content is not allowed to be outside the limits in accordance with Table 5.
8. Verify that Table 5 requirements are met.
9. When shown on the plans.

4.4.2.2. **Engineer's** Responsibilities.

- 4.4.2.2.1. Superpave Gyratory Compactor. The Engineer will use a Department SGC calibrated in accordance with [Tex-241-F](#) to mold samples for laboratory mixture design verification. For molding trial batch and production specimens, the Engineer will use the Contractor-provided SGC at the

field laboratory or provide and use a Department SGC at an alternate location.

4.4.2.2.2. Conditional Approval of JMF1 and Authorizing Trial Batch. The Engineer will review and verify conformance of the following information within two working days of receipt:

- the **Contractor's** mix design report (JMF1);
- the Contractor-provided Hamburg Wheel test results;
- all required materials including aggregates, asphalt, and additives; and
- the mixture specifications.

The Engineer will grant the Contractor conditional approval of JMF1 if the information provided on the paper copy of JMF1 indicates that the **Contractor's** mixture design meets the specifications. When the Contractor does not provide Hamburg Wheel test with laboratory mixture design, 10 working days are allowed for conditional approval of JMF1. The Engineer will base full approval of JMF1 on the test results on mixture from the trial batch.

Unless waived, the Engineer will determine the Micro-Deval abrasion loss in accordance with Section 3079.2.1.1.2., "**Micro-Deval Abrasion.**" If the **Engineer's** test results are pending after two working days, conditional approval of JMF1 will still be granted within two working days of receiving JMF1. When the **Engineer's** test results become available, they will be used for specification compliance.

The Contractor is authorized to produce a trial batch after the Engineer grants conditional approval of JMF1.

4.4.2.2.3. Hamburg Wheel Testing. At the **Contractor's** request, the Department will perform the Hamburg Wheel test on the laboratory mixture in accordance with [Tex-242-F](#) to verify compliance with the Hamburg Wheel test requirement in accordance with Table 5. The Engineer will be allowed 10 working days to provide the Contractor with Hamburg Wheel test results on the laboratory mixture design.

4.4.2.2.4. Ignition Oven Correction Factors. The Engineer will use the split samples provided by the Contractor to determine the aggregate and asphalt correction factors for the ignition oven used for QA testing during production in accordance with [Tex-236-F](#), Part II. Provide correction factors that are not more than 12 mo. old. The Engineer will verify that the asphalt content correction factor takes into account the percent fibers in the mixture so that the fibers are excluded from the binder content determination.

4.4.2.2.5. Testing the Trial Batch. Within one full working day, the Engineer will sample and test the trial batch to ensure that the mixture meets the requirements in accordance with Table 6. If the Contractor requests the option to have the Department perform the Hamburg Wheel test on the trial batch mixture, the Engineer will mold samples in accordance with [Tex-242-F](#) to verify compliance with the Hamburg Wheel test requirement in accordance with Table 5.

The Engineer will have the option to perform [Tex-530-C](#) on the trial batch when shown on the plans. These results may be retained and used for comparison purposes during production.

4.4.2.2.6. Full Approval of JMF1. The Engineer will grant full approval of JMF1 and authorize the Contractor to proceed with developing JMF2 if the **Engineer's** results for the trial batch meet the requirements in accordance with Table 5.

The Engineer will notify the Contractor that an additional trial batch is required if the trial batch does not meet these requirements.

4.4.2.2.7. Approval of JMF2. The Engineer will approve JMF2 within one working day if the mixture meets the requirements in accordance with Tables 4, 5, and 6.

- 4.4.2.2.8. Approval of Lot 1 Production. The Engineer will authorize the Contractor to proceed with Lot 1 production (using JMF2).
- 4.4.2.2.9. Approval of JMF3 and Subsequent JMF Changes. JMF3 and subsequent JMF changes are approved if they meet the master grading limits in accordance with Table 4, the asphalt binder content in accordance with Table 5, and are within the operational tolerances of JMF2 in accordance with Table 6.
- 4.4.2.2.10. Binder Content Adjustments. For JMF2 and above, the Engineer may require the Contractor to adjust the target binder content by no more than 0.3% from the current JMF.
- 4.5. Production Operations. Perform a new trial batch when the plant or plant location is changed. Take corrective action and receive approval to proceed after any production suspension for noncompliance to the specification.
- 4.5.1. Storage and Heating of Materials. Do not heat the asphalt binder above the temperatures specified in Item 300, “**Asphalts, Oils, and Emulsions,**” or outside the **manufacturer’s** recommended values. Provide the Engineer with daily records of asphalt binder and hot-mix asphalt discharge temperatures (in legible and discernible increments) in accordance with Item 320, “**Equipment for Asphalt Concrete Pavement,**” unless otherwise directed. Do not store mixture for a period long enough to affect the quality of the mixture, nor in any case longer than 12 hr. unless otherwise approved.
- 4.5.2. Mixing and Discharge of Materials. Notify the Engineer of the target discharge temperature and produce the mixture within 25°F of the target. Monitor the temperature of the material in the truck before shipping to ensure that it does not exceed the maximum production temperatures in accordance with Table 7. The Department will not pay for or allow placement of any mixture produced above the maximum production temperatures in accordance with Table 7.

Table 7
Maximum Production Temperature

High-Temperature Binder Grade ¹	Maximum Production Temperature
PG 76	345°F
A-R Binder	345°F

1. The high-temperature binder grade refers to the high-temperature grade of the virgin asphalt binder used to produce the mixture.

Control the mixing time and temperature so that substantially all moisture is removed from the mixture before discharging from the plant. Determine the moisture content, if requested, by oven-drying in accordance with [Tex-212-F](#), Part II, and verify that the mixture contains no more than 0.2% of moisture by weight. Obtain the sample immediately after discharging the mixture into the truck and perform the test promptly.

- 4.6. Hauling Operations. Clean all truck beds before use to ensure that mixture is not contaminated. Use a release agent, when necessary, shown on the **Department’s MPL** to coat the inside bed of the truck. **Do not use diesel or any release agent not shown on the Department’s MPL.**

Use equipment for hauling as defined in Section 3079.4.7.3.3., “**Hauling Equipment.**” Use other hauling equipment only when allowed.

- 4.7. Placement Operations. Collect haul tickets from each load of mixture delivered to the project and provide the **Department’s** copy to the Engineer approximately every hour or as directed. Use a hand-held thermal camera or infrared thermometer, when a thermal imaging system is not used, to measure and record the internal temperature of the mixture as discharged from the truck or Material Transfer Device (MTD) before or as the mix enters the paver and an approximate station number or GPS coordinates on each ticket. Calculate the daily yield and cumulative yield for the specified lift and provide to the Engineer at the end of paving operations for each day unless otherwise directed. The Engineer may suspend production if the Contractor fails to produce and provide haul tickets and yield calculations by the end of paving operations for each day.

Prepare the surface by removing raised pavement markers and objectionable material such as moisture, dirt, sand, leaves, and other loose impediments from the surface before placing mixture. Remove vegetation from

pavement edges. Place the mixture to meet the typical section requirements and produce a smooth, finished surface with a uniform appearance and texture. Offset longitudinal joints of successive courses of hot-mix by at least 6 in. Place mixture so that longitudinal joints on the surface course coincide within 6-in. of lane lines and are not placed in the wheel path, or as directed. Ensure that all finished surfaces will drain properly.

4.7.1. Weather Conditions.

- 4.7.1.1. When Using a Thermal Imaging System. The Contractor may pave any time the roadway is dry and the roadway surface temperature is at least 60°F unless otherwise approved or as shown on the plans; however, the Engineer may restrict the Contractor from paving if the ambient temperature is likely to drop below 32°F within 12 hr. of paving. Place mixtures when weather conditions and moisture conditions of the roadway surface are suitable as determined by the Engineer. Provide output data from the thermal imaging system to demonstrate to the Engineer that no recurring severe thermal segregation exists in accordance with Section 3079.4.7.3.1.2., **“Thermal Imaging System.”**

Produce mixture with a target discharge temperature higher than 300°F and with a compaction aid to facilitate compaction when the air temperature is 70°F and falling.

- 4.7.1.1.1. When Not Using a Thermal Imaging System. When using a thermal camera instead of the thermal imaging system, place mixture when the roadway surface temperature is at or above 70°F unless otherwise approved or as shown on the plans. Measure the roadway surface temperature with a hand-held thermal camera or infrared thermometer. Place mixtures only when weather conditions and moisture conditions of the roadway surface are suitable as determined by the Engineer. The Engineer may restrict the Contractor from paving if the air temperature is 60°F and falling.

Produce mixture with a target discharge temperature higher than 300°F and with a compaction aid to facilitate compaction when the air temperature is 70°F and falling.

4.7.2. Tack Coat.

- 4.7.2.1. Application. Clean the surface before placing the tack coat. The Engineer will set the rate between 0.04 and 0.10 gal. of residual asphalt per square yard of surface area. Apply a uniform tack coat at the specified rate unless otherwise directed. Apply the tack coat in a uniform manner to avoid streaks and other irregular patterns. Apply adequate overlap of the tack coat in the longitudinal direction during the placement of the mat to ensure bond of adjacent PFC mats, unless otherwise directed. Unless otherwise directed, avoid tacking the vertical faces of adjacent PFC mats in the longitudinal direction to avoid restricting lateral drainage. Apply tack coat to all transverse joints. Allow adequate time for emulsion to break completely before placing any material. Do not dilute emulsified asphalts at the terminal, in the field, or at any other location before use.

- 4.7.2.2. Sampling. The Engineer will obtain at least one sample of the tack coat binder per project in accordance with [Tex-500-C, Part III](#), and test it to verify compliance with Item 300, **“Asphalts, Oils, and Emulsions.”** The Engineer will notify the Contractor when the sampling will occur and will witness the collection of the sample from the asphalt distributor immediately before use. Label the can with the corresponding lot and subplot numbers, producer, producer facility, grade, district, date sampled, and project information including highway and CSJ. For emulsions, the Engineer may test as often as necessary to ensure the residual of the emulsion is **greater than or equal to the specification requirement in Item 300, “Asphalts, Oils, and Emulsions.”**

- 4.7.3. Lay-Down Operations. Use the placement temperature in accordance with Table 8 to establish the minimum placement temperature of the mixture delivered to the paving operation.

Table 8
Minimum Mixture Placement Temperature

High-Temperature Binder Grade ¹	Minimum Placement Temperature (Before Entering Paving Operation) ^{2,3}
PG 76	280°F
A-R Binder	280°F

1. The high-temperature binder grade refers to the high-temperature grade of the virgin asphalt binder used to produce the mixture.
2. The mixture temperature must be measured using a hand-held thermal camera or infrared thermometer nearest to the point of entry of the paving operation.
3. Minimum placement temperatures may be reduced 10°F if using a compaction aid.

4.7.3.1. Thermal Profile. Use a hand-held thermal camera or a thermal imaging system to obtain a continuous thermal profile in accordance with [Tex-244-F](#). Thermal profiles are not applicable in areas described in Section 3079.4.9.3.2., “Miscellaneous Areas.”

4.7.3.1.1. Thermal Segregation.

4.7.3.1.1.1. Moderate. Any areas that have a temperature differential greater than 25°F, but not exceeding 50°F.

4.7.3.1.1.2. Severe. Any areas that have a temperature differential greater than 50°F.

4.7.3.1.2. Thermal Imaging System. Review the output results when a thermal imaging system is used, and provide the report described in [Tex-244-F](#) to the Engineer daily. Modify the paving process as necessary to eliminate any recurring (moderate or severe) thermal segregation identified by the thermal imaging system.-

The Engineer may suspend subsequent paving operations if the Contractor cannot successfully modify the paving process to eliminate recurring severe or moderate thermal segregation.

Provide the Engineer with electronic copies of all daily data files that can be used with the thermal imaging system software to generate temperature profile plots daily or as requested by the Engineer.

4.7.3.1.2.1. Thermal Camera. When using a thermal camera instead of the thermal imaging system, take immediate corrective action to eliminate recurring moderate thermal segregation when a hand-held thermal camera is used. Provide the Engineer with the thermal profile of every subplot within one working day of the completion of each lot. When requested by the Engineer, provide the electronic files generated using the thermal camera. Report the results of each thermal profile in accordance with Section 3079.4.2., “Reporting and Responsibilities.” The Engineer will use a hand-held thermal camera to obtain a thermal profile at least once per project. Suspend operations and take immediate corrective action to eliminate severe thermal segregation unless otherwise directed. Resume operations when the Engineer determines that subsequent production will meet the requirements of this Section.

4.7.3.2. Windrow Operations. Operate windrow pickup equipment so that when hot-mix is placed in windrows, substantially all the mixture deposited on the roadbed is picked up and loaded into the paver.

4.7.3.3. Hauling Equipment. Use belly dumps, live bottom, or end dump trucks to haul and transfer mixture; however, with exception of paving miscellaneous areas, end dump trucks are only allowed when used in conjunction with an MTD with remixing capability or when a thermal imaging system is used unless otherwise allowed.

4.7.3.4. Screed Heaters. Turn off screed heaters to prevent overheating of the mat if the paver stops for more than 5 min. The Engineer may evaluate the suspect area in accordance with Section 3079.4.9.3.3., “Recovered Asphalt Dynamic Shear Rheometer (DSR),” if the screed heater remains on for more than 5 min. while the paver is stopped.

4.8. Compaction. Roll the freshly placed PFC with as many steel-wheeled rollers as necessary, operated in static mode, to seat the mixture without excessive breakage of the aggregate and to provide a smooth surface and uniform texture. Do not use pneumatic rollers. Moisten the roller drums thoroughly with a soap and water solution to prevent adhesion. Use only water or an approved release agent on rollers, tamps, and

other compaction equipment unless otherwise directed.

Use [Tex-246-F](#) to test and verify that the compacted mixture has adequate permeability. Measure the water flow once per subplot at locations directed by the Engineer. The water flow rate must be less than 20 sec. Investigate the cause of the water flow rate test failures and take corrective actions during production and placement to ensure the water flow rate is less than 20 sec. Suspend production if two consecutive water flow rate tests fail unless otherwise approved. Resume production after the Engineer approves changes to production or placement methods.

Complete all compaction operations before the pavement temperature drops below 180°F unless otherwise allowed. The Engineer may allow compaction with a light finish roller operated in static mode for pavement temperatures below 180°F.

Allow the compacted pavement to cool to 160°F or lower before opening to traffic unless otherwise directed. Sprinkle the finished mat with water or limewater, when directed, to expedite opening the roadway to traffic.

- 4.9. Acceptance Plan. Sample and test the hot-mix on a lot and subplot basis.
- 4.9.3. Referee Testing. The Materials and Tests Division is the referee laboratory. The Contractor may request referee testing if the differences between Contractor and Engineer test results exceed the operational tolerances in accordance with Table 6 and the differences cannot be resolved. The Contractor may also request referee testing if the **Engineer's** test results require suspension of production and the **Contractor's** test results are within specification limits. Make the request within five working days after receiving test results and cores from the Engineer. Referee tests will be performed only on the subplot in question and only for the particular tests in question. Allow 10 working days from the time the referee laboratory receives the samples for test results to be reported. The Department may require the Contractor to reimburse the Department for referee tests if more than three referee tests per project are required and the **Engineer's** test results are closer to the referee test results than the **Contractor's** test results.
- 4.9.4. Production Acceptance.
- 4.9.4.1. Production Lot. A production lot consists of four equal sublots. The default quantity for Lot 1 is 1,000 ton; however, when requested by the Contractor, the Engineer may increase the quantity for Lot 1 to no more than 2,000 ton. The Engineer will select subsequent lot sizes based on the anticipated daily production such that approximately three to four sublots are produced each day. The lot size will be between 1,000 ton and 4,000 ton. The Engineer may change the lot size before the Contractor begins any lot.
- 4.9.4.1.1. Incomplete Production Lots. If a lot is begun but cannot be completed, such as on the last day of production or in other circumstances deemed appropriate, the Engineer may close the lot. Close all lots within five working days unless otherwise allowed.
- 4.9.4.2. Production Sampling.
- 4.9.4.2.1. Mixture Sampling. Obtain hot-mix samples from trucks at the plant in accordance with [Tex-222-F](#). The sampler will split each sample into three equal portions in accordance with [Tex-200-F](#) and label these portions as "**Contractor**," "**Engineer**," and "**Referee**." The Engineer will perform or witness the sample splitting and take immediate possession of the samples labeled "**Engineer**" and "**Referee**." The Engineer will maintain the custody of the samples labeled "**Engineer**" and "**Referee**" until the **Department's** testing is completed.
- 4.9.4.2.1.1. Random Sample. At the beginning of the project, the Engineer will select random numbers for all production sublots. Determine sample locations in accordance with [Tex-225-F](#). Take one sample for each subplot at the randomly selected location. The Engineer will perform or witness the sampling of production sublots.
- 4.9.4.2.1.2. Blind Sample. For one subplot per lot, the Engineer will obtain and test a "**blind**" sample instead of the random sample collected by the Contractor. Test either the "**blind**" or the random sample; however, referee testing (if applicable) will be based on a comparison of results from the "**blind**" sample. The location of the **Engineer's** "**blind**" sample will not be disclosed to the Contractor. The **Engineer's** "**blind**" sample may be randomly selected in accordance with [Tex-225-F](#) for any subplot or selected at the discretion of the Engineer. The

Engineer will use the **Contractor's** split sample for sublots not sampled by the Engineer.

- 4.9.4.2.2. Informational Shear Bond Strength Testing. Select one random subplot from Lot 2 or higher for shear bond strength testing. Obtain full depth cores in accordance with [Tex-249-F](#). Label the cores with the Control Section Job (CSJ), producer of the tack coat, mix type, shot rate, lot, and subplot number and provide to the Engineer. The Engineer will ship the cores to the Materials and Tests Division or district laboratory for shear bond strength testing. Results from these tests will not be used for specification compliance.
- 4.9.4.2.3. Informational Hamburg and Overlay Testing. Select one random subplot from Lot 2 or higher for Hamburg and Overlay testing during the first week of production. Obtain and provide the Engineer with approximately 90 lb. of mixture, sampled in accordance with [Tex-222-E](#), in sealed containers, boxes, or bags labeled with the Control-Section-Job (CSJ), mixture type, lot, and subplot number. The Engineer will ship the mixture to the Materials and Tests Division for Hamburg and Overlay testing. Results from these tests will not be used for specification compliance.
- 4.9.4.2.4. Asphalt Binder Sampling. Obtain a 1 qt. (1 gal. for A-R binder) sample of the asphalt binder witness by the Engineer for each lot of mixture produced. The Contractor will notify the Engineer when the sampling will occur. Obtain the sample at approximately the same time the mixture random sample is obtained. Sample from a port located immediately upstream from the mixing drum or pug mill and upstream from the introduction of any additives in accordance with [Tex-500-C](#), Part II. Label the can with the corresponding lot and subplot numbers, producer, producer facility, grade, district, date sampled, and project information including highway and CSJ. The Engineer will retain these samples for one year. The Engineer may also obtain independent samples. If obtaining an independent asphalt binder sample and upon request of the Contractor, the Engineer will split a sample of the asphalt binder with the Contractor

At least once per project, the Engineer will collect split samples of each binder grade and source used. The Engineer will submit one split sample to the Materials and Tests Division to verify compliance with Item 300, "Asphalts, Oils, and Emulsions" and will retain the other split sample for one year.

- 4.9.4.3. Production Testing. The Contractor and Engineer must perform production tests in accordance with Table 9. **The Contractor has the option to verify the Engineer's test results on split samples provided by the Engineer.** Determine compliance with operational tolerances in accordance with Table 6 for all sublots.

At any time during production, the Engineer may require the Contractor to verify the following based on quantities used:

- lime content (within $\pm 0.1\%$ of JMF), when PG binder is specified;
- fiber content (within $\pm 0.03\%$ of JMF), when PG binder is specified; and
- CRM content (within $\pm 1.5\%$ of JMF), when A-R binder is specified.

Maintain the in-line measuring device when A-R binder is specified to verify the A-R binder viscosity between 2,500 and 4,000 centipoise at 350°F unless otherwise approved. Record A-R binder viscosity at least once per hour and provide the Engineer with a daily summary unless otherwise directed.

If the aggregate mineralogy is such that [Tex-236-F](#), Part I does not yield reliable results, the Engineer may allow alternate methods for determining the asphalt content and aggregate gradation. The Engineer will require the Contractor to provide evidence that results from [Tex-236-F](#), Part I are not reliable before permitting an alternate method unless otherwise allowed. Use the applicable test procedure as directed if an alternate test method is allowed.

Table 9
Production and Placement Testing Frequency

Description	Test Method	Minimum Contractor Testing Frequency	Minimum Engineer Testing Frequency
Individual % retained for sieve sized larger than #200	Tex-200-F	1 per subplot	1 per 12 sublots
% passing the #200 sieve			
Laboratory-molded density, %	Tex-207-F , Part VIII	1 per subplot	1 per lot
Asphalt binder content ¹ , %	Tex-236-F , Part I ²	1 per subplot	1 per lot
Drain-down, %	Tex-235-F	1 per subplot	1 per 12 sublots
Boil test ³	Tex-530-C	1 per project	1 per project
Moisture content	Tex-212-F , Part II	When directed	1 per project
Cantabro loss, %	Tex-245-F	1 per project (sample only)	1 per project
Overlay test	Tex-248-F	1 per project (sample only)	1 per project ^{4,9}
Hamburg Wheel test	Tex-242-F	1 per project (sample only)	1 per project ^{4,9}
Water flow test	Tex-246-F	1 per subplot	1 per project
Asphalt binder sampling	Tex-500-C , Part II	1 per lot (sample only) ⁵	1 per project
Tack coat sampling and testing	Tex-500-C , Part III	N/A	1 per project
Thermal profile	Tex-244-F	1 per subplot, ^{6,7,8}	1 per project ⁷

1. May be obtained from t mass flow meter readouts as determined by the Engineer.
2. Ensure the binder content determination excludes fibers.
3. When shown on the plans.
4. Testing performed by the Materials and Tests Division on sample obtained from Lot 2 or higher.
5. Obtain samples witness by the Engineer. The Engineer will retain these samples for one year.
6. To be performed in the presence of the Engineer when using the thermal camera, unless otherwise approved.
7. Not required when a thermal imaging system is used.
8. When using the thermal imaging system, the test report must include the temperature measurements taken in accordance with Tex-244-F.
9. Testing performed by the Materials and Tests Division for informational purposes only.

4.9.4.4. Operational Tolerances. Control the production process within the operational tolerances in accordance with Table 6. Suspend production and placement operations when production or placement test results exceed the tolerances in accordance with Table 6 unless otherwise allowed. When production is suspended, the Engineer will allow production to resume when test results or other information indicates the next mixture produced will be within the operational tolerances.

4.9.4.5. Individual Loads of Hot-Mix. The Engineer can reject individual truckloads of hot-mix. When a load of hot-mix is rejected for reasons other than temperature, contamination, or excessive uncoated particles, the Contractor may request that the rejected load be tested. Make this request within 4 hr. of rejection. The Engineer will sample and test the mixture. If test results are within the operational tolerances in accordance with Table 6, payment will be made for the load. If test results are not within operational tolerances, no payment will be made for the load.

4.9.5. Placement Acceptance.

4.9.5.1. Placement Lot. A placement lot consists of four placement sublots. A placement subplot consists of the area placed during a production subplot.

4.9.5.2. Miscellaneous Areas. Miscellaneous areas include areas that typically involve significant handwork or discontinuous paving operations such as driveways, mailbox turnouts, crossovers, gores, spot level-up

areas, and other similar areas. The specified layer thickness is based on the rate of 90 lb. per square yard for each inch of pavement unless another rate is shown on the plans. Miscellaneous areas are not subject to thermal profiles testing.

4.9.5.3. Recovered Asphalt Dynamic Shear Rheometer (DSR). The Engineer may take production samples or cores from suspect areas of the project to determine recovered asphalt properties. Asphalt binders with an aging ratio greater than 3.5 do not meet the requirements for recovered asphalt properties and may be deemed defective when tested and evaluated by the Materials and Tests Division. The aging ratio is the DSR value of the extracted binder divided by the DSR value of the original unaged binder. Obtain DSR values in accordance with AASHTO T 315 at the specified high temperature performance grade of the asphalt. The Engineer may require removal and replacement of the defective material at the **Contractor's** expense. The asphalt binder will be recovered for testing from production samples or cores in accordance with [Tex-211-F](#).

4.9.5.4. Irregularities. Identify and correct irregularities, including segregation, rutting, raveling, flushing, fat spots, mat slippage, irregular color, irregular texture, roller marks, tears, gouges, streaks, uncoated aggregate particles, or broken aggregate particles. The Engineer may also identify irregularities, and in such cases, the Engineer will promptly notify the Contractor. If the Engineer determines that the irregularity will adversely affect pavement performance, the Engineer may require the Contractor to remove and replace (at the **Contractor's** expense) areas of the pavement that contain irregularities. The Engineer may also require the Contractor to remove **and replace (at the Contractor's expense)** areas where the mixture does not bond to the existing pavement.

If irregularities are detected, the Engineer may require the Contractor to immediately suspend operations or may allow the Contractor to continue operations for no more than one day while the Contractor is taking appropriate corrective action.

4.9.6. Exempt Production. When the anticipated daily production is less than 100 ton, all QC and QA sampling and testing are waived. The Engineer may deem the mixture as exempt production for the following conditions:

- anticipated daily production is more than 100 ton but less than 250 ton;
- total production for the project is less than 2,500 ton;
- when mutually agreed between the Engineer and the Contractor; or
- when shown on the plans.

For exempt production, the Contractor is relieved of all production and placement sampling and testing requirements. All other specification requirements apply, and the Engineer will perform acceptance tests for production and placement in accordance with Table 9.

For exempt production:

- produce, haul, place, and compact the mixture as directed by the Engineer; and
- control mixture production to yield a laboratory-molded density that is within $\pm 1.0\%$ of the target density as tested by the Engineer.

4.9.7. Ride Quality. Measure ride quality in accordance with Item 585, "**Ride Quality for Pavement Surfaces,**" unless otherwise shown on the plans.

5. MEASUREMENT

5.1. PFC Hot-Mix Asphalt. Permeable friction course (PFC) hot-mix will be measured by the ton of composite mixture which includes asphalt, aggregate, and additives. Measure the weight on scales in accordance with Item 520, "Weighing and Measuring Equipment."

5.2. Tack Coat. Tack coat will be measured at the applied temperature by strapping the tank before and after road application and determining the net volume in gallons from the calibrated distributor. The Engineer will witness all strapping operations for volume determination. All tack, including emulsions, will be measured by the gallon applied.

The Engineer may allow the use of a metering device to determine asphalt volume used and application rate if the device is accurate to within 1.5% of the strapped volume.

6. PAYMENT

The work performed and materials furnished in accordance with this Item and measured as provided under Section 3079.5.1., "PFC Hot-Mix Asphalt," will be paid for at the unit bid price for "Permeable friction course Hot Mix Asphalt" of the mixture type, SAC, and binder specified. These prices are full compensation for surface preparation, materials, placement, equipment, labor, tools, and incidentals.

The work performed and materials furnished in accordance with this Item and measured as provided under Section 3079.5.2., "Tack Coat," **will be paid for at the unit bid price for "Tack Coat"** of the tack coat provided. These prices are full compensation for materials, placement, equipment, labor, tools, and incidentals.

Trial batches will not be paid for unless they are included in pavement work approved by the Department.

Payment adjustment for ride quality will be determined in accordance with Item 585, "**Ride Quality for Pavement Surfaces.**"

Special Specification 3081

Thin Overlay Mixtures



1. DESCRIPTION

Construct a thin surface course composed of a compacted mixture of aggregate and asphalt binder mixed hot in a mixing plant. Produce a thin overlay mixture (TOM) with a minimum lift thickness of 1/2 in. for a Type F mixture and 3/4 in. for a Type C mixture.

2. MATERIALS

Furnish uncontaminated materials of uniform quality that meet the requirements of the plans and specifications.

Notify the Engineer of all material sources and before changing any material source or formulation. The Engineer will verify that the specification requirements are met when the Contractor makes a source or formulation change, and may require a new laboratory mixture design, trial batch, or both. The Engineer may sample and test project materials at any time during the project to verify specification compliance in accordance with Item 6, "Control of Materials."

2.1. **Aggregate.** Furnish aggregates from sources that conform to the requirements in accordance with Table 1 and as specified in this Section. Aggregate requirements in this Section, including those shown in Table 1, may be modified or eliminated when shown on the plans. Additional aggregate requirements may be specified when shown on the plans. Provide aggregate stockpiles that meet the definitions in this Section for coarse, intermediate, or fine aggregate. Do not use reclaimed asphalt pavement (RAP) or recycled asphalt shingles (RAS). Supply aggregates that meet the definitions in accordance with [Tex-100-E](#) for crushed gravel or crushed stone. The Engineer will designate the plant or the quarry as the sampling location. Provide samples from materials produced for the project. The Engineer will establish the Surface Aggregate Classification (SAC) and perform Los Angeles abrasion, magnesium sulfate soundness, and Micro-Deval tests. Perform all other aggregate quality tests in accordance with Table 1. Document all test results on the mixture design report. The Engineer may perform tests on independent or split samples to verify Contractor test results. Stockpile aggregates for each source and type separately. Determine aggregate gradations for mixture design and production testing based on the washed sieve analysis in accordance with [Tex-200-F](#), Part II.

2.1.1. **Coarse Aggregate.** Coarse aggregate stockpiles must have no more than 20% material passing the No. 8 sieve. Aggregates from sources listed in the Department's *Bituminous Rated Source Quality Catalog* (BRSQC) are preapproved for use. Use only the rated values for hot-mix listed in the BRSQC. Rated values for surface treatment (ST) do not apply to coarse aggregate sources used in hot-mix asphalt.

For sources not listed on the Department's BRSQC:

- build an individual stockpile for each material;
- request the Department test the stockpile for specification compliance;
- approved only when tested by the Engineer;
- once approved, do not add material to the stockpile unless otherwise approved; and
- allow 30 calendar days for the Engineer to sample, test, and report results.

2.1.1.1. **Blending Class A and Class B Aggregates.** Class B aggregate meeting all other requirements in blending Class A and B aggregates to meet a Class A requirement, ensure that at least 50% by weight, or volume if required, of all aggregates used in the mixture design retained on the No. 8 sieve comes from the Class A

aggregate source, unless otherwise shown on the plans. Blend by volume if the bulk specific gravities of the Class A and B aggregates differ by more than 0.300. Class B aggregate may be disallowed when shown on the plans.

The Engineer may perform tests at any time during production, when the Contractor blends Class A and B aggregates to meet a Class A requirement, to ensure that at least 50% by weight, or volume if required, of the material retained on the No. 8 sieve comes from the Class A aggregate source. The Engineer will use the Department's mix design template, when electing to verify conformance, to calculate the percent of Class A aggregate retained on the No. 8 sieve by inputting the bin percentages shown from readouts in the control room at the time of production and stockpile gradations measured at the time of production. The Engineer may determine the gradations based on either washed or dry sieve analysis from samples obtained from individual aggregate cold feed bins or aggregate stockpiles. The Engineer may perform spot checks using the gradations supplied by the Contractor on the mixture design report as an input for the template; however, a failing spot check will require confirmation with a stockpile gradation determined by the Engineer.

- 2.1.1.2. **Micro-Deval Abrasion.** The Engineer will perform a minimum of one Micro-Deval abrasion test in accordance with [Tex-461-A](#) for each coarse aggregate source used in the mixture design that has a Rated Source Soundness Magnesium (RSSM) loss value greater than 15 as listed in the BRSQC, unless otherwise directed. The Engineer will perform testing before the start of production and may perform additional testing at any time during production. The Engineer may obtain the coarse aggregate samples from each coarse aggregate source or may require the Contractor to obtain the samples. The Engineer may waive all Micro-Deval testing based on a satisfactory test history of the same aggregate source.

The Engineer will estimate the magnesium sulfate soundness loss for each coarse aggregate source, when tested, using the following formula:

$$Mg_{est.} = (RSSM)(MD_{act}/RSMD)$$

where:

Mg_{est} = magnesium sulfate soundness loss

$RSSM$ = Rated Source Soundness Magnesium

MD_{act} = actual Micro-Deval percent loss

$RSMD$ = Rated Source Micro-Deval

When the estimated magnesium sulfate soundness loss is greater than the maximum magnesium sulfate soundness loss specified, the coarse aggregate source will not be allowed for use unless otherwise approved. The Engineer will consult the Soils and Aggregates Section of the Materials and Tests Division, and additional testing may be required before granting approval.

- 2.1.2. **Intermediate Aggregate.** Aggregates not meeting the definition of coarse or fine aggregate will be defined as intermediate aggregate. Supply intermediate aggregates, when used that are free from organic impurities. The Engineer may test the intermediate aggregate in accordance with [Tex-408-A](#) to verify the material is free from organic impurities. Supply intermediate aggregate from coarse aggregate sources, when used that meet the requirements in accordance with Table 1 unless otherwise approved.

If 10% or more of the stockpile is retained on the No. 4 sieve, verify that it meets the requirements in accordance with Table 1 for crushed face count ([Tex-460-A](#)) and flat and elongated particles ([Tex-280-F](#)).

- 2.1.3. **Fine Aggregate.** Fine aggregates consist of manufactured sands and screenings. Natural sands are not allowed in any mixture. Fine aggregate stockpiles must meet the fine aggregate properties in accordance with Table 1 and the gradation requirements in accordance with Table 2. Supply fine aggregates that are free from organic impurities. The Engineer may test the fine aggregate in accordance with [Tex-408-A](#) to verify the material is free from organic impurities. Use fine aggregate from coarse aggregate sources that meet the requirements in accordance with Table 1 unless otherwise approved.

If 10% or more of the stockpile is retained on the No. 4 sieve, verify that it meets the requirements in accordance with Table 1 for crushed face count ([Tex-460-A](#)) and flat and elongated particles ([Tex-280-F](#)).

Table 1
Aggregate Quality Requirements

Property	Test Method	Requirement
Coarse Aggregate		
SAC	Tex-499-A	A ¹
Deleterious material, %, Max	Tex-217-F , Part I	1.5
Decantation, %, Max	Tex-217-F , Part II	1.5
Micro-Deval abrasion, %	Tex-461-A	Note ^f
Los Angeles abrasion, %, Max	Tex-410-A	30
Magnesium sulfate soundness, 5 cycles, %, Max	Tex-411-A	20
Crushed face count, ³ %, Min	Tex-460-A , Part I	95
Flat and elongated particles @ 5:1, %, Max	Tex-280-F	10
Fine Aggregate		
Linear shrinkage, %, Max	Tex-107-E	3
Sand equivalent, %, Min	Tex-203-F	45

1. Surface Aggregate Classification of "A" is required unless otherwise shown on the plans.
2. Used to estimate the magnesium sulfate soundness loss in accordance with Section 3081.2.1.1.2., "Micro-Deval Abrasion."
3. Only applies to crushed gravel.

Table 2
Gradation Requirements for Fine Aggregate

Sieve Size	% Passing by Weight or Volume
3/8"	100
#8	70-100
#200	0-30

- 2.2. **Mineral Filler.** Mineral filler consists of finely divided mineral matter such as agricultural lime, crusher fines, or hydrated lime. Mineral filler is allowed unless otherwise shown on the plans. Fly ash is not permitted unless otherwise shown on the plans. Use no more than 2% hydrated lime unless otherwise shown on the plans. Test all mineral fillers except hydrated lime and fly ash in accordance with [Tex-107-E](#) to ensure specification compliance. The plans may require or disallow specific mineral fillers. Provide mineral filler, when used, that:
- is sufficiently dry, free-flowing, and free from clumps and foreign matter as determined by the Engineer;
 - does not exceed 3% linear shrinkage when tested in accordance with [Tex-107-E](#); and
 - meets the gradation requirements in Table 3, unless otherwise shown on the plans.

Table 3
Gradation Requirements for Mineral Filler

Sieve Size	% Passing by Weight or Volume
#8	100
#200	55-100

- 2.3. **Baghouse Fines.** Fines collected by the baghouse or other dust-collecting equipment may be reintroduced into the mixing drum.
- 2.4. **Asphalt Binder.** Furnish performance-graded (PG) asphalt binder with a high temperature grade of PG 76 unless otherwise shown in the plans and a low temperature grade as shown on the plans, in accordance with Section 300.2.10., "Performance-Graded Binders."
- 2.5. **Tack Coat.** Furnish CSS-1H, SS-1H, EBL, or a PG binder with a minimum high-temperature grade of PG 58 for tack coat binder in accordance with Item 300, "Asphalts, Oils, and Emulsions." Specialized tack coat materials listed on the Department's Tracking Resistant Asphalt Interlayer (TRAIL) MPL may be allowed or required when shown on the plans. Do not dilute emulsified asphalts at the terminal, in the field, or at any other location before use.

- 2.6. **Additives.** Provide the Engineer with documentation such as the bill of lading showing the quantity of additives used in the project unless otherwise directed.
- 2.6.1. **Lime and Liquid Antistripping Agent.** When lime or a liquid antistripping agent is used, add in accordance with Item 301, "Asphalt Antistripping Agents." Use no more than 1% hydrated lime when using crushed gravel. Do not add lime directly into the mixing drum of any plant where lime is removed through the exhaust stream unless the plant has a baghouse or dust collection system that reintroduces the lime into the drum.
- 2.6.2. **Compaction Aid.** Compaction Aid is defined as a department-approved chemical warm mix additive denoted as "chemical additive" on the Department's materials producer list (MPL) that is used to facilitate mixing and compaction of HMA.
- Compaction Aid is allowed for use on all projects. Compaction aid is required when shown on the plans or as required in Section 3081.4.7.1., "Weather Conditions."
- Warm mix foaming processes, denoted as "foaming process" on the Department-approved MPL, may be used to facilitate mixing and compaction of HMA; however warm mix foaming processes are not defined as a Compaction Aid.
- 2.7. **Recycled Materials.** Recycled materials are not allowed for use.

3. EQUIPMENT

Provide required or necessary equipment in accordance with Item 320, "Equipment for Asphalt Concrete Pavement."

4. CONSTRUCTION

Produce, haul, place, and compact the specified paving mixture. In addition to tests required by the specification, Contractors may perform other QC tests as deemed necessary. At any time during the project, the Engineer may perform production and placement tests as deemed necessary in accordance with Item 5, "Control of the Work." Schedule and participate in a mandatory pre-paving meeting with the Engineer on or before the first day of paving unless otherwise shown on the plans.

- 4.1. **Certification.** Personnel certified by the Department-approved hot-mix asphalt certification program must conduct all mixture designs, sampling, and testing in accordance with Table 4. Supply the Engineer with a list of certified personnel and copies of their current certificates before beginning production and when personnel changes are made. Provide a mixture design developed and signed by a Level 2 certified specialist. Provide Level 1A certified specialists at the plant during production operations. Provide Level 1B certified specialists to conduct placement tests. Provide AGG101 certified specialists for aggregate testing.

Table 4
Test Methods, Test Responsibility, and Minimum Certification Levels

Test Description	Test Method	Contractor	Engineer	Level ¹
1. Aggregate Testing				
Sampling	Tex-221-F	✓	✓	1A/AGG101
Dry sieve	Tex-200-F , Part I	✓	✓	1A/AGG101
Washed sieve	Tex-200-F , Part II	✓	✓	1A/AGG101
Deleterious material	Tex-217-F , Part I	✓	✓	AGG101
Decantation	Tex-217-F , Part II	✓	✓	AGG101
Los Angeles abrasion	Tex-410-A		✓	Department
Magnesium sulfate soundness	Tex-411-A		✓	Department
Micro-Deval abrasion	Tex-461-A		✓	AGG101
Crushed face count	Tex-460-A	✓	✓	AGG101
Flat and elongated particles	Tex-280-F	✓	✓	AGG101
Sand equivalent	Tex-203-F	✓	✓	AGG101
Organic impurities	Tex-408-A	✓	✓	AGG101
Methylene blue test	Tex-252-F		✓	Department
2. Asphalt Binder & Tack Coat Sampling				
Asphalt binder sampling	Tex-500-C , Part II	✓	✓	1A/1B
Tack coat sampling	Tex-500-C , Part III	✓	✓	1A/1B
3. Mix Design & Verification				
Design and JMF changes	Tex-204-F	✓	✓	2
Mixing	Tex-205-F	✓	✓	2
Molding (TGC)	Tex-206-F	✓	✓	1A
Molding (SGC)	Tex-241-F	✓	✓	1A
Laboratory-molded density	Tex-207-F , Parts I & VI	✓	✓	1A
Rice gravity	Tex-227-F , Part II	✓	✓	1A
Drain-down	Tex-235-F	✓	✓	1A
Ignition oven correction factors ²	Tex-236-F , Part II	✓	✓	2
Indirect tensile strength	Tex-226-F	✓	✓	1A
Overlay test	Tex-248-F		✓	Department
Hamburg Wheel test	Tex-242-F	✓	✓	1A
Boil test ⁴	Tex-530-C	✓	✓	1A
4. Production Testing				
Selecting production random numbers	Tex-225-F , Part I		✓	1A
Mixture sampling	Tex-222-F	✓	✓	1A/1B
Molding (TGC)	Tex-206-F	✓	✓	1A
Molding (SGC)	Tex-241-F	✓	✓	1A
Laboratory-molded density	Tex-207-F , Parts I & VI	✓	✓	1A
Rice gravity	Tex-227-F , Part II	✓	✓	1A
Gradation & asphalt binder content ²	Tex-236-F , Part I	✓	✓	1A
Drain-down	Tex-235-F	✓	✓	1A
Control charts	Tex-233-F	✓	✓	1A
Moisture content	Tex-212-F , Part II	✓	✓	1A/AGG101
Hamburg Wheel test	Tex-242-F	✓	✓	1A
Overlay test	Tex-248-F	✓	✓	Department
Micro-Deval abrasion	Tex-461-A		✓	AGG101
Boil test ⁴	Tex-530-C	✓	✓	1A
Abson recovery	Tex-211-F		✓	Department
5. Placement Testing				
Establish rolling pattern	Tex-207-F , Part IV	✓		1B
In-place density (nuclear method)	Tex-207-F , Part III	✓		1B
Control charts	Tex-233-F	✓	✓	1A
Ride quality measurement	Tex-1001-S	✓	✓	Note 3
Thermal profile	Tex-244-F	✓	✓	1B
Water flow test	Tex-246-F	✓	✓	1B

- Level 1A, 1B, AGG101, and 2 are certification levels provided by the Hot Mix Asphalt Center certification program.
- Refer to Section 3081.4.9.2.3., "Production Testing," for exceptions to using an ignition oven.
- Profiler and operator are required to be certified at the Texas A&M Transportation Institute facility when Surface Test Type B is specified.
- When shown on the plans.

4.2.

Reporting and Responsibilities. Use Department-provided templates to record and calculate all test data, including mixture design, production and placement QC/QA, control charts, and thermal profiles. Obtain the current version of the templates at <https://www.txdot.gov/inside-txdot/forms-publications/consultants-contractors/forms/site-manager.html> or from the Engineer. The Engineer and the Contractor will provide any available test results to the other party when requested. The maximum allowable time for the Contractor and Engineer to exchange test data is as given in Table 5 unless otherwise approved. The Engineer and the Contractor will immediately report to the other party any test result that requires suspension of production or placement or that fails to meet the specification requirements. Record and electronically submit all test results and pertinent information on Department-provided templates.

Subsequent sublots placed after test results are available to the Contractor, which require suspension of operations, may be considered unauthorized work. Unauthorized work will be accepted or rejected at the discretion of the Engineer in accordance with Section 5.3., "Conformity with Plans, Specifications, and Special Provisions."

**Table 5
Reporting Schedule**

Description	Reported By	Reported To	To Be Reported Within
<i>Production Quality Control</i>			
Gradation ¹	Contractor	Engineer	1 working day of completion of the subplot
Asphalt binder content ¹			
Laboratory-molded density ²			
Moisture content ³			
Boil test ⁵			
<i>Production Quality Assurance</i>			
Gradation ³	Engineer	Contractor	1 working day of completion of the subplot
Asphalt binder content ³			
Laboratory-molded density ¹			
Hamburg Wheel test ⁴			
Overlay test ⁴			
Boil test ⁵			
Binder tests ⁴			
<i>Placement Quality Control</i>			
Thermal profile ¹	Contractor	Engineer	1 working day of completion of the lot
Water flow ¹			
<i>Placement Quality Assurance</i>			
Thermal profile ³	Engineer	Contractor	1 working day of completion of the lot
Aging ratio ⁴			
Water flow			

1. These tests are required on every subplot.
2. Optional test. When performed on split samples, report the results as soon as they become available.
3. To be performed at the frequency specified and in accordance with Table 13 or as shown on the plans.
4. To be reported as soon as the results become available.
5. When shown on the plans.

Use the procedures described in [Tex-233-F](#) to plot the results of all quality control (QC) and quality assurance (QA) testing. Update the control charts as soon as test results for each subplot become available. Make the control charts readily accessible at the field laboratory. The Engineer may suspend production for failure to update control charts.

4.3.

Quality Control Plan (QCP). Develop and follow the QCP in detail. Obtain approval for changes to the QCP made during the project. The Engineer may suspend operations if the Contractor fails to comply with the QCP.

Submit a written QCP before the mandatory pre-paving meeting. Receive approval of the QCP before pre-paving meeting. Include the following items in the QCP:

- 4.3.1. **Project Personnel.** For project personnel, include:
- a list of individuals responsible for QC with authority to take corrective action;
 - current contact information for each individual listed; and
 - current copies of certification documents for individuals performing specified QC functions.
- 4.3.2. **Material Delivery and Storage.** For material delivery and storage, include:
- the sequence of material processing, delivery, and minimum quantities to assure continuous plant operations;
 - aggregate stockpiling procedures to avoid contamination and segregation;
 - frequency, type, and timing of aggregate stockpile testing to assure conformance of material requirements before mixture production; and
 - procedure for monitoring the quality and variability of asphalt binder.
- 4.3.3. **Production.** For production, include:
- loader operation procedures to avoid contamination in cold bins;
 - procedures for calibrating and controlling cold feeds;
 - procedures to eliminate debris or oversized material;
 - procedures for adding and verifying rates of each applicable mixture component (e.g., aggregate, asphalt binder, lime, liquid antistripping, compaction aid, foaming process);
 - procedures for reporting job control test results; and
 - procedures to avoid segregation and drain-down in the silo.
- 4.3.4. **Loading and Transporting.** For loading and transporting, include:
- type and application method for release agents; and
 - truck loading procedures to avoid segregation.
- 4.3.5. **Placement and Compaction.** For placement and compaction, include:
- proposed agenda for mandatory pre-paving meeting, including date and location;
 - proposed paving plan (e.g., production rate, paving widths, joint offsets, and lift thicknesses);
 - type and application method for release agents in the paver and on rollers, shovels, lutes, and other utensils;
 - procedures for the transfer of mixture into the paver, while avoiding physical and thermal segregation and preventing material spillage;
 - process to balance production, delivery, paving, and compaction to achieve continuous placement operations and good ride quality;
 - paver operations (e.g., speed, operation of wings, height of mixture in auger chamber) to avoid physical and thermal segregation and other surface irregularities; and
 - procedures to construct quality longitudinal and transverse joints.
- 4.4. **Mixture Design.**
- 4.4.1. **Design Requirements.** The Contractor may design the mixture using a Texas Gyrotory Compactor (TGC) or a Superpave Gyrotory Compactor (SGC) unless otherwise shown on the plans. Use the typical weight design example given in [Tex-204-F](#), Part I, when using a TGC. Use the Superpave mixture design procedure provided in [Tex-204-F](#), Part IV, when using a SGC. Design the mixture to meet the requirements in accordance with Tables 1, 2, 3, 6, and 7.
- 4.4.1.1. **Target Laboratory-Molded Density When the TGC Is Used.** Design the mixture at a 97.5% target laboratory-molded density or in accordance with Table 7.

4.4.1.2.

Design Number of Gyration (N_{design}) When the SGC Is Used. Design the mixture at 50 gyrations (N_{design}). Use a target laboratory-molded density of 96.0% to design the mixture; however, adjustments can be made to the N_{design} value as noted in Table 7. The N_{design} level may be reduced to no less than 35 gyrations at the Contractor's discretion.

Use an approved laboratory from the Department's MPL to perform the Hamburg Wheel test, and the Department will perform the Overlay test and provide results with the mixture design, or provide the laboratory mixture and request that the Department perform the Hamburg Wheel test and Overlay test. The Engineer will be allowed 10 working days to provide the Contractor with Hamburg Wheel test and Overlay test results on the laboratory mixture design.

The Engineer will provide the mixture design when shown on the plans. The Contractor may submit a new mixture design at any time during the project. The Engineer will verify and approve all mixture designs (JMF 1) before the Contractor can begin production.

Provide the Engineer with a mixture design report using the Department-provided template. Include the following items in the report:

- the combined aggregate gradation, source, specific gravity, and percent of each material used;
- the target laboratory-molded density (or N_{design} level when using the SGC);
- results of all applicable tests;
- the mixing and molding temperatures;
- the signature of the Level 2 person or persons that performed the design;
- the date the mixture design was performed; and
- a unique identification number for the mixture design.

Table 6
Master Gradation Limits (% Passing by Weight or Volume) and Volumetric Requirements

Sieve Size	Coarse (TOM-C)	Fine (TOM-F)
1/2"	100.0 ¹	100.0 ¹
3/8"	95.0–100.0	98.0–100.0
#4	40.0–60.0	70.0–95.0
#8	17.0–27.0	40.0–65.0
#16	5.0–27.0	20.0–45.0
#30	5.0–27.0	10.0–35.0
#50	5.0–27.0	10.0–20.0
#200	5.0–9.0	2.0–12.0
Asphalt Binder Content,² % Min		
-	6.0	6.5
Design VMA,³ % Min		
-	16.0	16.5
Production (Plant-Produced) VMA,³ % Min		
-	15.5	16.0

1. Defined as maximum sieve size. No tolerance allowed.
2. Unless otherwise shown on the plans or approved by the Engineer.
3. Voids in Mineral Aggregates (VMA).

Table 7
Mixture Design Properties

Mixture Property	Test Method	Requirement
Target laboratory-molded density, % (TGC)	Tex-207-F	97.5 ¹
Design gyrations (N _{design} for SGC)	Tex-241-F	50 ²
Hamburg Wheel test, passes at 12.5 mm rut depth for PG 76 mixtures	Tex-242-F	20,000 Min
Overlay test, Critical Fracture Energy, lb.-in/sq. in	Tex-248-F	1.5 Min
Overlay test, Crack Progression Rate	Tex-248-F	0.40 Max
Drain-down, %	Tex-235-F	0.20 Max

1. Unless otherwise shown on the plans or approved by the Engineer. Laboratory-molded density requirement using the TGC may be waived when approved by the Engineer.

2. May be adjusted within the range of 35–100 gyrations when shown on the plans or specification or when mutually agreed between the Engineer and Contractor. Laboratory-molded density requirement using the SGC may be waived when approved by the Engineer.

- 4.4.1 **Job-Mix Formula Approval.** The job-mix formula (JMF) is the combined aggregate gradation, target laboratory-molded density (or Ndesign level), and target asphalt percentage used to establish target values for hot-mix production. JMF1 is the original laboratory mixture design used to produce the trial batch. When a compaction aid or foaming process is used, JMF1 may be designed and submitted to the Engineer without including the compaction aid or foaming process. When a compaction aid or foaming process is used, document the compaction aid or foaming process used and recommended rate on the JMF1 submittal. The Engineer and the Contractor will verify JMF1 based on plant-produced mixture from the trial batch unless otherwise approved. The Engineer may accept an existing mixture design previously used on a Department project and may waive the trial batch to verify JMF1. The Department may require the Contractor to reimburse the Department for verification tests if more than two trial batches per design are required.
- 4.4.2.1. **Contractor's Responsibilities.**
- 4.4.2.1.1. **Providing Gyrotory Compactor.** Use a TGC calibrated in accordance with [Tex-914-K](#) when electing or required to design the mixture in accordance with [Tex-204-E](#), Part I, for molding production samples. Furnish an SGC calibrated in accordance with [Tex-241-F](#) when electing or required to design the mixture in accordance with [Tex-204-F](#), Part IV, for molding production samples. Locate the SGC if used, at the Engineer's field laboratory or make the SGC available to the Engineer for use in molding production samples.
- 4.4.2.1.2. **Gyrotory Compactor Correlation Factors.** Use [Tex-206-F](#), Part II, to perform a gyrotory compactor correlation when the Engineer uses a different gyrotory compactor. Apply the correlation factor to all subsequent production test results.
- 4.4.2.1.3. **Submitting JMF1.** Furnish a mix design report (JMF1) with representative samples of all component materials and request approval to produce the trial batch. Provide approximately 25 lb. of the design mixture if opting to have the Department perform the Hamburg Wheel test on the laboratory mixture, and request that the Department perform the test. Provide approximately 60 lb. of the design mixture to perform the Overlay test.
- 4.4.2.1.4. **Supplying Aggregates.** Provide approximately 40 lb. of each aggregate stockpile unless otherwise directed.
- 4.4.2.1.5. **Supplying Asphalt.** Provide at least 1 gal. of the asphalt material and enough quantities of any additives proposed for use.
- 4.4.2.1.6. **Ignition Oven Correction Factors.** Determine the aggregate and asphalt correction factors from the ignition oven in accordance with [Tex-236-F](#), Part II. Provide correction factors that are not more than 12 mo. old. Provide the Engineer with split samples of the mixtures before the trial batch production, including all additives (except water), and blank samples used to determine the correction factors for the ignition oven used for QA testing during production. Correction factors established from a previously approved mixture design may be used for the current mixture design if the mixture design and ignition oven are the same as previously used and the correction factors are not more than 12 mo. old, unless otherwise directed.
- 4.4.2.1.7. **Boil Test.** When shown on the plans, perform the test and retain the tested sample from [Tex-530-C](#) until completion of the project or as directed. Use this sample for comparison purposes during production.
- 4.4.2.1.8. **Trial Batch Production.** Provide a plant-produced trial batch upon receiving conditional approval of JMF1 and authorization to produce a trial batch, including the compaction aid or foaming process, if applicable, for verification testing of JMF1 and development of JMF2. Produce a trial batch mixture that meets the requirements in accordance with Table 8. The Engineer may accept test results from recent production of the same mixture instead of a new trial batch.

- 4.4.2.1.9. **Trial Batch Production Equipment.** Use only equipment and materials proposed for use on the project to produce the trial batch.
- 4.4.2.1.10. **Trial Batch Quantity.** Produce enough quantity of the trial batch to ensure that the mixture meets the specification requirements.
- 4.4.2.1.11. **Number of Trial Batches.** Produce trial batches as necessary to obtain a mixture that meets the specification requirements.
- 4.4.2.1.12. **Trial Batch Sampling.** Obtain a representative sample of the trial batch and split it into three equal portions in accordance with [Tex-222-F](#). Label these portions as "Contractor," "Engineer," and "Referee." Deliver samples to the appropriate laboratory as directed.
- 4.4.2.1.13. **Trial Batch Testing.** Test the trial batch to ensure the mixture produced using the proposed JMF1 meets the mixture requirements in accordance with Table 8. Ensure the trial batch mixture is also in compliance with the requirements in accordance with Tables 6 and 7. Use a Department-approved laboratory listed on the MPL to perform the Hamburg Wheel test on the trial batch mixture or request that the Department perform the Hamburg Wheel test. Provide approximately 25 lb. of the trial batch mixture if opting to have the Department perform the Hamburg Wheel test, and request that the Department perform the test. Obtain and provide approximately 60 lb. of trial batch mixture in sealed containers, boxes, or bags labeled with the CSJ, mixture type, lot, and subplot number in accordance with [Tex-222-F](#) for the Overlay test. The Engineer will be allowed 10 working days to provide the Contractor with Hamburg Wheel test and Overlay test results on the trial batch. Provide the Engineer with a copy of the trial batch test results.
- 4.4.2.1.14. **Development of JMF2.** Evaluate the trial batch test results after the Engineer grants full approval of JMF 1 based on results from the trial batch, determine the optimum mixture proportions, and submit as JMF 2. Adjust the asphalt binder content or gradation to achieve the specified target laboratory-molded density. The mixture produced using JMF 2 must meet the requirements in accordance with Tables 6 and 7. Verify that JMF2 meets the operation tolerances of JMF 1 in accordance with Table 8.
- 4.4.2.1.15. **Mixture Production.** Use JMF2 to produce Lot 1 after receiving approval for JMF2 and a passing result from the Department's or a Department-approved laboratory's Hamburg Wheel test and the Department's Overlay test on the trial batch. If desired, proceed to Lot 1 production, once JMF 2 is approved, at the Contractor's risk without receiving the results from either the Department's Hamburg Wheel test or Overlay test on the trial batch.
- Notify the Engineer if electing to proceed without Hamburg Wheel test and Overlay test results from the trial batch. Note that the Engineer may require up to the entire subplot of any mixture failing the Hamburg Wheel test or Overlay test to be removed and replaced at the Contractor's expense.
- 4.4.2.1.16. **Development of JMF3.** Evaluate the test results from Lot 1, determine the optimum mixture proportions, and submit as JMF3 for use in Lot 2.
- 4.4.2.1.17. **JMF Adjustments.** If JMF adjustments are necessary to achieve the specified requirements, make the adjustments before beginning a new lot. The adjusted JMF must:
- be provided to the Engineer in writing before the start of a new lot;
 - be numbered in sequence to the previous JMF;
 - meet the master gradation limits in accordance with Table 6; and
 - be within the operational tolerances of JMF 2 in accordance with Table 8.
- 4.4.2.1.18. **Requesting Referee Testing.** Use referee testing, if needed, in accordance with Section 3081.4.9.1., "Referee Testing," to resolve testing differences with the Engineer.

Table 8
Operational Tolerances

Description	Test Method	Allowable Difference between JMF2 and JMF1 Target ¹	Allowable Difference from Current JMF and JMF2 ²	Allowable Difference between Contractor and Engineer ³
Individual % retained for #8 sieve and larger	Tex-200-F or Tex-236-F	Must be Within Master Grading Limits in accordance with Table 6	±3.0 ^{4,5}	±5.0
Individual % retained for sieves smaller than #8 and larger than #200			±3.0 ^{4,5}	±3.0
% passing the #200 sieve			±2.0 ^{4,5}	±1.6
Asphalt binder content, % ⁶	Tex-236-F	±0.3	±0.3 ⁵	±0.3
Laboratory-molded density, %	Tex-207-F	±1.0	±1.0	±1.0
Laboratory-molded bulk specific gravity		N/A	N/A	±0.020
VMA, % Min	Tex-204-F	Note 7	Note 7	N/A
Theoretical Max specific (Rice) gravity	Tex-227-F	N/A	N/A	±0.020
Drain-down, %	Tex-235-F	Note 8	Note 8	N/A

1. JMF1 is the approved laboratory mixture design used for producing the trial batch. JMF2 is the approved mixture design developed from the trial batch used to produce Lot 1.
2. Current JMF is JMF3 or higher. JMF3 is the approved mix design used to produce Lot 2.
3. Contractor may request referee testing only when values exceed these tolerances.
4. When within these tolerances, mixture production gradations may fall outside the master grading limits; however, the % passing the #200 will be considered out of tolerance when outside the master grading limits.
5. Only applies to mixture produced for Lot 1 and higher.
6. Binder content is not allowed to be outside the limits in accordance with Table 6. May be obtained from asphalt meter readouts as determined by the Engineer.
7. Verify that Table 6 requirements are met.
8. Verify that Table 7 requirements are met.

4.4.2.2. Engineer's Responsibilities.

4.4.2.2.1. **Gyratory Compactor.** For mixtures designed in accordance with [Tex-204-F](#), Part I, the Engineer will use a Department TGC, calibrated in accordance with [Tex-914-K](#), to mold samples for trial batch and production testing.

For mixtures designed in accordance with [Tex-204-F](#), Part IV, the Engineer will use a Department SGC, calibrated in accordance with [Tex-241-F](#), to mold samples for laboratory mixture design verification. For molding trial batch and production specimens, the Engineer will use the Contractor-provided SGC at the field laboratory or provide and use a Department SGC at an alternate location.

4.4.2.2.2. **Conditional Approval of JMF1 and Authorizing Trial Batch.** The Engineer will review and verify conformance of the following information within two working days of receipt:

- the Contractor's mix design report (JMF1);
- the Department-provided Overlay test results;
- the Contractor-provided Hamburg Wheel test results;
- all required materials including aggregates, asphalt, and additives; and
- the mixture specifications.

The Engineer will grant the Contractor conditional approval of JMF1 if the information provided on the paper copy of JMF1 indicates that the Contractor's mixture design meets the specifications. When the Contractor does not provide Hamburg Wheel test and department provided Overlay test results with laboratory mixture design, 10 working days are allowed for conditional approval of JMF1. The Engineer will base full approval of JMF1 on test results on mixture from the trial batch.

Unless waived, the Engineer will determine the Micro-Deval abrasion loss in accordance with

Section 3081.2.1.1., "Micro-Deval Abrasion." If the Engineer's test results are pending after two working days, conditional approval of JMF1 will still be granted within two working days of receiving JMF1. When the Engineer's test results become available, they will be used for specification compliance.

The Contractor is authorized to produce a trial batch after the Engineer grants conditional approval of JMF1.

- 4.4.2.2.3. **Hamburg Wheel and Overlay Testing of JMF1.** If the Contractor requests the option to have the Department perform the Hamburg Wheel test on the laboratory mixture, the Engineer will mold samples in accordance with [Tex-242-F](#) to verify compliance with the Hamburg Wheel test requirement in Table 7. The Engineer will perform the Overlay test and mold samples in accordance with [Tex-248-F](#) to verify compliance with the Overlay test requirements in Table 7. The Engineer will be allowed 10 working days to provide the Contractor with Hamburg Wheel and Overlay test results on the laboratory mixture design.
- 4.4.2.2.4. **Ignition Oven Correction Factors.** The Engineer will use the split samples provided by the Contractor to determine the aggregate and asphalt correction factors for the ignition oven used for QA testing during production in accordance with [Tex-236-F](#), Part II. Provide correction factors that are not more than 12 mo. old.
- 4.4.2.2.5. **Testing the Trial Batch.** Within one full working day, the Engineer will sample and test the trial batch to ensure that the mixture meets the requirements in accordance with Table 8. The Engineer will mold samples in accordance with [Tex-242-F](#) if the Contractor requests the option to have the Department perform the Hamburg Wheel test on the trial batch mixture to verify compliance with Hamburg Wheel test requirements in Table 7. The Engineer will mold samples for the Overlay test in accordance with [Tex-248-F](#) to verify compliance with the Overlay test requirement in Table 7.
- The Engineer will have the option to perform [Tex-530-C](#) on the trial batch when shown on the plans. These results may be retained and used for comparison purposes during production.
- 4.4.2.2.6. **Full Approval of JMF1.** The Engineer will grant full approval of JMF1 and authorize the Contractor to proceed with developing JMF2 if the Engineer's results for the trial batch meet the requirements in accordance with Tables 6 and 7. The Engineer will notify the Contractor that an additional trial batch is required if the trial batch does not meet these requirements.
- 4.4.2.2.7. **Approval of JMF2.** The Engineer will approve JMF2 within one working day if the mixture meets the requirements in accordance with Table 6, 7, and 8.
- 4.4.2.2.8. **Approval of Lot 1 Production.** The Engineer will authorize the Contractor to proceed with Lot 1 production (using JMF2) as soon as a passing result is achieved from the Department's or a Department-approved laboratory's Hamburg Wheel test and the Department's Overlay test on the trial batch. The Contractor may proceed at its own risk with Lot 1 production without the results from the Hamburg Wheel test or Overlay test on the trial batch.
- If the Department's or Department-approved laboratory's sample from the trial batch fails the Hamburg Wheel test or Overlay test, the Engineer will suspend production until further Hamburg Wheel tests or Overlay tests meet the specified values. The Engineer may require up to the entire subplot of any mixture failing the Hamburg Wheel test or Overlay test to be removed and replaced at the Contractor's expense.
- 4.4.2.2.9. **Approval of JMF3 and Subsequent JMF Changes.** JMF3 and subsequent JMF changes are approved if they meet the master grading limits and asphalt binder content shown in Table 6 and are within the operational tolerances of JMF2 shown in accordance with Table 8.
- 4.5. **Production Operations.** Perform a new trial batch when the plant or plant location is changed. Take corrective action and receive approval to proceed after any production suspension for noncompliance to the specification.

4.5.1. **Storage and Heating of Materials.** Do not heat the asphalt binder above the temperatures specified in Item 300, "Asphalts, Oils, and Emulsions," or outside the manufacturer's recommended values. Provide the Engineer with daily records of asphalt binder and hot-mix asphalt discharge temperatures (in legible and discernible increments) in accordance with Item 320, "Equipment for Asphalt Concrete Pavement," unless otherwise directed. Do not store mixture for a period long enough to affect the quality of the mixture, nor in any case longer than 12 hr. unless otherwise approved.

4.5.2. **Mixing and Discharge of Materials.** Notify the Engineer of the target discharge temperature and produce the mixture within 25°F of the target. Monitor the temperature of the material in the truck before shipping to ensure that it does not exceed the maximum production temperatures in accordance with Table 9. The Department will not pay for or allow placement of any mixture produced above the maximum production temperatures listed in Table 9.

**Table 9
Maximum Production Temperature**

High-Temperature Binder Grade ¹	Max Production Temperature
PG 76	345°F

1. The high-temperature binder grade refers to the high-temperature grade of the virgin asphalt binder used to produce the mixture.

Control the mixing time and temperature so that substantially all moisture is removed from the mixture before discharging from the plant. Determine the moisture content, if requested, by oven-drying in accordance with [Tex-212-F](#), Part II, and verify that the mixture contains no more than 0.2% of moisture by weight. Obtain the sample immediately after discharging the mixture into the truck and perform the test promptly.

4.6. **Hauling Operations.** Clean all truck beds before use to ensure that mixture is not contaminated. Use a release agent shown on the Department's MPL to coat the inside bed of the truck when necessary. Do not use diesel or any release agent not shown on the Department's MPL.

Use equipment for hauling as defined in Section 3081.4.7.3.3., "Hauling Equipment." Use other hauling equipment only when allowed.

4.7. **Placement Operations.** Collect haul tickets from each load of mixture delivered to the project and provide the Department's copy to the Engineer approximately every hour, or as directed. Use a hand-held thermal camera or infrared thermometer, when a thermal imaging system is not used, to measure and record the internal temperature of the mixture as discharged from the truck or Material Transfer Device (MTD) before or as the mix enters the paver and an approximate station number or GPS coordinates on each ticket. Calculate the daily yield and cumulative yield for the specified lift and provide to the Engineer at the end of paving operations for each day unless otherwise directed. The Engineer may suspend production if the Contractor fails to produce and provide haul tickets and yield calculations by the end of paving operations for each day.

Prepare the surface by removing raised pavement markers and objectionable material such as moisture, dirt, sand, leaves, and other loose impediments from the surface before placing mixture. Remove vegetation from pavement edges. Place the mixture to meet the typical section requirements and produce a smooth, finished surface with a uniform appearance and texture. Place mixture so that longitudinal joints on the surface course coincide within 6-in. of lane lines and are not placed in the wheel path, or as directed, and offset longitudinal joints of successive courses of hot-mix by at least 6-in. Ensure that all finished surfaces will drain properly. Place the mixture at the rate or thickness shown on the plans. The Engineer will use the guidelines in Table 10 to determine the compacted lift thickness. The thickness determined is based on the rate of 110–115 lb. per square inch. for each inch of pavement unless otherwise shown on the plans.

Table 10
Compacted Lift Thickness

Mixture Type	Compacted Lift Thickness ¹	
	Min (in.)	Max (in.)
TOM-C	0.75	1.25
TOM-F	0.5	1.00

1. Compacted target lift thickness will be specified on the plans.

4.7.1. Weather Conditions.

4.7.1.1. **When Using a Thermal Imaging System.** The Contractor may pave any time the roadway is dry and the roadway surface temperature is at least 60°F unless otherwise approved or as shown on the plans; however, the Engineer may restrict the Contractor from paving surface mixtures if the ambient temperature is likely to drop below 32°F within 12 hr. of paving. Place mixtures only when weather conditions and moisture conditions of the roadway surface are suitable as determined by the Engineer. Provide output data from the thermal imaging system to demonstrate to the Engineer that no recurring severe thermal segregation exists in accordance with Section 3081.4.7.3.1.2., "Thermal Imaging System."

Produce mixture with a target discharge temperature higher than 300°F and with a compaction aid to facilitate compaction when the air temperature is 70°F and falling

4.7.1.2. **When Not Using a Thermal Imaging System.** When using a thermal camera instead the thermal imaging system, place mixture when the roadway surface temperature is at or above 70°F unless otherwise approved or as shown on the plans. Measure the roadway surface temperature with a hand-held thermal camera or infrared thermometer. Place mixtures only when weather conditions and moisture conditions of the roadway surface are suitable as determined by the Engineer. The Engineer may restrict the Contractor from paving if the air temperature is 70°F and falling.

Produce mixture with a target discharge temperature higher than 300°F and with a compaction aid to facilitate compaction when the air temperature is 70°F and falling.

4.7.2. Tack Coat.

4.7.2.1. **Application.** Clean the surface before placing the tack coat. The Engineer will set the rate between 0.04 and 0.10 gal. of residual asphalt per square yard of surface area, unless otherwise specified on the plans. Apply a uniform tack coat at the specified rate unless otherwise directed. Apply the tack coat in a uniform manner to avoid streaks and other irregular patterns. Apply the tack coat to all surfaces that will come in contact with the subsequent HMA placement unless otherwise directed. Apply adequate overlap of the tack coat in the longitudinal direction during placement of the mat to ensure bond of adjacent mats, unless otherwise directed. Allow adequate time for emulsion to break completely before placing any material. Prevent splattering of tack coat when placed adjacent to curb, gutter, and structures. The Engineer may suspend paving operations until there is adequate coverage. Do not dilute emulsified asphalts at the terminal, in the field, or at any other location before use.

4.7.2.2. **Sampling.** The Engineer will obtain at least one sample of the tack coat binder per project in accordance with [Tex-500-C](#), Part III, and test it to verify compliance with Item 300, "Asphalts, Oils, and Emulsions." The Engineer will notify the Contractor when the sampling will occur and will witness the collection of the sample from the asphalt distributor immediately before use. Label the can with the corresponding lot and subplot numbers, producer, producer facility, grade, district, date sampled, and project information including highway and CSJ. For emulsions, the Engineer may test as often as necessary to ensure the residual of the emulsion is greater than or equal to the specification requirement in Item 300, "Asphalts, Oils, and Emulsions."

4.7.3. **Lay-Down Operations.** Use the placement temperatures in accordance with Table 11 to establish the minimum placement temperature of mixture delivered to the paving operation.

Table 11
Minimum Mixture Placement Temperature

High-Temperature Binder Grade ¹	Min Placement Temperature (Before Entering Paving Operation) ^{2,3}
PG 76	280°F

1. The high-temperature binder grade refers to the high-temperature grade of the virgin asphalt binder used to produce the mixture.
2. The mixture temperature must be measured using a hand-held thermal camera or infrared thermometer nearest to the point of entry of the paving operation.
3. Minimum placement temperatures may be reduced 10°F if using a compaction aid.

4.7.3.1. **Thermal Profile.** Use a hand-held thermal camera or a thermal imaging system to obtain a continuous thermal profile in accordance with [Tex-244-F](#).

4.7.3.1.1. **Thermal Segregation.**

4.7.3.1.1.1. **Moderate.** Any areas that have a temperature differential greater than 25°F, but not exceeding 50°F.

4.7.3.1.1.2. **Severe.** Any areas that have a temperature differential greater than 50°F.

4.7.3.1.2. **Thermal Imaging System.** Review the output results when a thermal imaging system is used, and provide the report described in accordance with [Tex-244-F](#) to the Engineer daily. Modify the paving process as necessary to eliminate any recurring (moderate or severe) thermal segregation identified by the thermal imaging system.

The Engineer may suspend subsequent paving operations if the Contractor cannot successfully modify the paving process to eliminate recurring severe or moderate thermal segregation.

Provide the Engineer with electronic copies of all daily data files that can be used with the thermal imaging system software to generate temperature profile plots daily or as requested by the Engineer.

4.7.3.1.3. **Thermal Camera.** When using a thermal camera instead of the thermal imaging system, take immediate corrective action to eliminate recurring moderate thermal segregation when a hand-held thermal camera is used. Evaluate areas with moderate thermal segregation by performing water flow testing in accordance with [Tex-246-F](#) and verify the water flow is greater than 120 sec. Provide the Engineer with the thermal profile of every subplot within one working day of the completion of each lot. When requested by the Engineer, provide the electronic files generated using the thermal camera. Report the results of each thermal profile in accordance with Section 3081.4.2., "Reporting and Responsibilities." The Engineer will use a hand-held thermal camera to obtain a thermal profile at least once per project, unless the thermal imaging system is used. Suspend operations and take immediate corrective action to eliminate severe thermal segregation unless otherwise directed. Resume operations when the Engineer determines that subsequent production will meet the requirements of this Section. Evaluate areas with severe thermal segregation by performing water flow testing in accordance with [Tex-246-F](#) and verify the water flow is greater than 120 sec. Remove and replace the material in any areas that have both severe thermal segregation and a failing result for water flow test unless otherwise directed.

4.7.3.2. **Windrow Operations.** Operate windrow pickup equipment so that when hot-mix is placed in windrows, substantially all the mixture deposited on the roadbed is picked up and loaded into the paver.

4.7.3.3. **Hauling Equipment.** Use belly dumps, live bottom, or end dump trucks to haul and transfer mixture. End dump trucks are only allowed when used in conjunction with an MTD with remixing capability unless otherwise allowed.

4.7.3.4. **Screed Heaters.** Turn off screed heaters to prevent overheating of the mat if the paver stops for more than 5 min. The Engineer may evaluate the suspect area in accordance with Section 3081.4.9.3.1.1., "Recovered Asphalt Dynamic Shear Rheometer (DSR)," if the screed heater remains on for more than 5 min. while the paver is stopped.

4.8.

Compaction. Roll the freshly placed mixture with as many steel-wheeled rollers as necessary to ensure adequate compaction without excessive breakage of the aggregate and to provide a smooth surface and uniform texture. Operate each roller in static mode for TOM-F mixtures only. Do not use pneumatic-tire rollers. Use the control strip method given in accordance with [Tex-207-F](#), Part IV, to establish the rolling pattern. Thoroughly moisten the roller drums with a soap and water solution to prevent adhesion. Use only water or an approved release agent on rollers, tamps, and other compaction equipment unless otherwise directed.

Use tamps to thoroughly compact the edges of the pavement along curbs, headers, and similar structures and in locations that will not allow thorough compaction with rollers. The Engineer may require rolling with a trench roller on widened areas, in trenches, and in other limited areas.

Use [Tex-246-F](#) to measure water flow to verify the mixture is adequately compacted. Measure the water flow once per subplot at locations directed by the Engineer. Take additional water flow measurements when the minimum temperature of the uncompacted mat is below the temperature requirements in accordance with Table 12.

Table 12
Minimum Uncompacted Mat Temperature Requiring Additional Water Flow Measurements

High-Temperature Binder Grade ¹	Min Temperature of the Uncompacted Mat Allowed Before Initial Break Down Rolling ^{2,3}
PG 76	<270°F

1. The high-temperature binder grade refers to the high-temperature grade of the virgin asphalt binder used to produce the mixture.
2. The surface of the uncompacted mat must be measured using a hand-held thermometer or infrared thermometer.
3. Minimum uncompacted mat temperature requiring a water flow measurement may be reduced 10°F if using a compaction aid.

Use [Tex-246-F](#) to measure water flow to verify the mixture is adequately compacted at confined longitudinal joints as directed by the Engineer.

The water flow rate should be greater than 120 sec. Investigate the cause of the water flow rate test failures and take corrective actions during production and placement to ensure the water flow rate is greater than 120 sec. Suspend production if two consecutive water flow rate tests fail unless otherwise approved. Resume production after the Engineer approves changes to production or placement methods.

Complete all compaction operations before the pavement temperature drops below 180°F unless otherwise allowed. The Engineer may allow compaction with a light finish roller operated in static mode for pavement temperatures below 180°F when approved.

Allow the compacted pavement to cool to 160°F or lower before opening to traffic unless otherwise directed. Sprinkle the finished mat with water or limewater, when directed, to expedite opening the roadway to traffic.

4.9.

Acceptance Plan. Sample and test the hot-mix asphalt on a lot and subplot basis.

4.9.1.

Referee Testing. The Materials and Tests Division is the referee laboratory. The Contractor may request referee testing if the differences between Contractor and Engineer test results exceed the maximum allowable difference in accordance with Table 8 and the differences cannot be resolved. The Contractor may also request referee testing if the Engineer's test results require suspension of production and the Contractor's test results are within specification limits. Make the request within five working days after receiving test results from the Engineer. Referee tests will be performed only on the subplot in question and only for the particular tests in question. Allow 10 working days from the time the referee laboratory receives the samples for test results to be reported. The Department may require the Contractor to reimburse the Department for referee tests if more than three referee tests per project are required and the Engineer's test results are closer to the referee test results than the Contractor's test results.

The Materials and Tests Division will determine the laboratory-molded density based on the molded specific gravity and the maximum theoretical specific gravity of the referee sample.

4.9.2. **Production Acceptance.**

4.9.2.1. **Production Lot.** A production lot consists of four equal sublots. The default quantity for Lot 1 is 500 ton; however, when requested by the Contractor, the Engineer may increase the quantity for Lot 1 to no more than 2,000 ton. The Engineer will select subsequent lot sizes based on the anticipated daily production such that approximately three to four sublots are produced each day. The lot size will be between 500 ton and 2,000 ton. The Engineer may change the lot size before the Contractor begins any lot.

4.9.2.1.1. **Incomplete Production Lots.** If a lot is begun but cannot be completed, such as on the last day of production or in other circumstances deemed appropriate, the Engineer may close the lot. Close all lots within five working days unless otherwise allowed.

4.9.2.2. **Production Sampling.**

4.9.2.2.1. **Mixture Sampling.** Obtain hot-mix samples from trucks at the plant in accordance with [Tex-222-F](#). The sampler will split each sample into three equal portions in accordance with [Tex-200-F](#) and label these portions as "Contractor," "Engineer," and "Referee." The Engineer will perform or witness the sample splitting and take immediate possession of the samples labeled "Engineer" and "Referee." The Engineer will maintain the custody of the samples labeled "Engineer" and "Referee" until the Department's testing is completed.

4.9.2.2.1.1. **Random Sample.** At the beginning of the project, the Engineer will select random numbers for all production sublots. Determine sample locations in accordance with [Tex-225-F](#). Take one sample for each subplot at the randomly selected location. The Engineer will perform or witness the sampling of production sublots.

4.9.2.2.1.2. **Blind Sample.** For one subplot per lot, the Engineer will obtain and test a "blind" sample instead of the random sample collected by the Contractor. Test either the "blind" or the random sample; however, referee testing (if applicable) will be based on a comparison of results from the "blind" sample. The location of the Engineer's "blind" sample will not be disclosed to the Contractor. The Engineer's "blind" sample may be randomly selected in accordance with [Tex-225-F](#) for any subplot or selected at the discretion of the Engineer. The Engineer will use the Contractor's split sample for sublots not sampled by the Engineer.

4.9.2.2.2. **Informational Methylene Blue Testing.** During the project and at random, obtain and provide the Engineer with approximately 50 lb. of each fine aggregate and approximately 20 lb. of all mineral fillers used to produce the mixture. Label the samples with the Control Section Job (CSJ), mixture type, and approximate lot and subplot number corresponding to when the sample was taken. The Engineer will ship the samples to the Materials and Tests Division for Methylene Blue testing in accordance with [Tex-252-F](#). Results from these tests will not be used for specification compliance.

4.9.2.2.3. **Asphalt Binder Sampling.** Obtain a 1-qt. sample of the asphalt binder witnessed by the Engineer for each lot of mixture produced. The Contractor will notify the Engineer when the sampling will occur. Obtain the sample at approximately the same time the mixture random sample is obtained. Sample from a port located immediately upstream from the mixing drum or pug mill and upstream from the introduction of any additives in accordance with [Tex-500-C](#), Part II. Label the can with the corresponding lot and subplot numbers, producer, producer facility location, grade, district, date sampled, and project information including highway and CSJ. The Engineer will retain these samples for one year. The Engineer may also obtain independent samples. If obtaining an independent asphalt binder sample and upon request of the Contractor, the Engineer will split a sample of the asphalt binder with the Contractor.

At least once per project, the Engineer will collect split samples of each binder grade and source used. The Engineer will submit one split sample to the Materials and Tests Division to verify compliance with Item 300, "Asphalts, Oils, and Emulsions," and will retain the other split sample for 1 yr.

4.9.2.3. **Production Testing.** The Contractor and Engineer must perform production tests in accordance with Table 13. The Contractor has the option to verify the Engineer's test results on split samples provided by the Engineer. Determine compliance with operational tolerances listed in accordance with Table 8 for all sublots. Take immediate corrective action if the Engineer's laboratory-molded density on any subplot is less than 95.0% or greater than 98.0% when using the SGC or less than 96.5% or greater than 98.5% when using the TGC, to bring

the mixture within these tolerances. The Engineer may suspend operations if the Contractor's corrective actions do not produce acceptable results. The Engineer will allow production to resume when the proposed corrective action is likely to yield acceptable results.

The Engineer may allow alternate methods for determining the asphalt binder content and aggregate gradation if the aggregate mineralogy is such that [Tex-236-F](#), Part I does not yield reliable results. Provide evidence that results from [Tex-236-F](#), Part I are not reliable before requesting permission to use an alternate method unless otherwise directed. Use the applicable test procedure as directed if an alternate test method is allowed.

Table 13
Production and Placement Testing Frequency

Description	Test Method	Min Contractor Testing	Min Engineer Testing
Individual % retained for #8 sieve and larger	Tex-200-F or Tex-236-F	1 per subplot	1 per 12 sublots ¹
Individual % retained for sieves smaller than #8 and larger than #200			
% passing the #200 sieve			
Laboratory-molded density	Tex-207-F	N/A	1 per subplot ¹
Laboratory-molded bulk specific gravity			
VMA			
Moisture content	Tex-212-F , Part II	When directed	
Theoretical maximum specific (Rice) gravity	Tex-227-F , Part II	N/A	1 per subplot ¹
Asphalt binder content ²	Tex-236-F , Part I	1 per subplot	1 per lot ¹
Overlay test ³	Tex-248-F	N/A	1 per project
Hamburg Wheel test	Tex-242-F	N/A	1 per project
Thermal profile	Tex-244-F	1 per subplot ^{4,5,6}	1 per project ⁵
Asphalt binder sampling and testing	Tex-500-C , Part II	1 per lot (sample only) ⁷	1 per project
Tack coat sampling and testing	Tex-500-C , Part III	N/A	1 per project
Boil test ⁸	Tex-530-C	1 per subplot ⁹	1 per project
Water flow	Tex-246-F		
Methylene blue test ¹⁰	Tex-252-F	1 per project (sample only)	1 per project

1. For production defined in Section 3081.4.9.4., "Exempt Production," the Engineer will test one per day if 100 ton or more are produced. For Exempt Production, no testing is required with less than 100 ton are produced.
2. May be obtained from asphalt flow meter readout as determined by the Engineer.
3. Testing performed by the Materials and Tests Division on sample obtained from Lot 2 or higher.
4. To be performed in the presence of the Engineer when a thermal camera is used, unless otherwise approved.
5. Not required when a thermal imaging system is used.
6. When using the thermal imaging system, the test report must include the temperature measurements taken in accordance with [Tex-244-F](#).
7. Obtain samples witnessed by the Engineer. The Engineer will retain these samples for 1 yr.
8. When shown on the plans.
9. To be performed in the presence of the Engineer, unless otherwise directed.
10. Testing performed by the Materials and Tests Division for informational purposes only.

4.9.2.4. **Operational Tolerances.** Control the production process within the operational tolerances in accordance with Table 8. When production is suspended, the Engineer will allow production to resume when test results or other information indicates the next mixture produced will be within the operational tolerances.

4.9.2.4.1. **Gradation.** Suspend operation and take corrective action if any aggregate is retained on the maximum sieve size in accordance with Table 6. A subplot is defined as out of tolerance if either the Engineer's or the Contractor's test results are out of operational tolerance. Suspend production when test results for gradation exceed the operational tolerances in accordance with Table 8 for three consecutive sublots on the same sieve or four consecutive sublots on any sieve unless otherwise directed. The consecutive sublots may be from more than one lot.

4.9.2.4.2. **Asphalt Binder Content.** A subplot is defined as out of operational tolerance if either the Engineer's or the Contractor's test results exceed the values in accordance with Table 8. Suspend production when two or

more sublots within a lot are out of operational tolerance or below the minimum asphalt binder content specified in accordance with Table 6 unless otherwise directed. Suspend production and shipment of mixture if the Engineer's or Contractor's asphalt binder content deviates from the current JMF by more than 0.5% for any subplot or is less than the minimum asphalt content allowed in accordance with Table 6.

- 4.9.2.4.3. **Voids in Mineral Aggregates (VMA).** The Engineer will determine the VMA for every subplot. For sublots when the Engineer does not determine asphalt binder content, the Engineer will use the asphalt binder content results from QC testing performed by the Contractor to determine VMA.

Take immediate corrective action if the VMA value for any subplot is less than the minimum VMA requirement for production in accordance with Table 6. Suspend production and shipment of the mixture if the Engineer's VMA results on two consecutive sublots are below the minimum VMA requirement for production in accordance with Table 6.

Suspend production and shipment of the mixture if the Engineer's VMA result is more than 0.5% below the minimum VMA requirement for production in accordance with Table 6. In addition to suspending production, the Engineer may require removal and replacement or may allow the subplot to be left in place without payment.

- 4.9.2.4.4. **Hamburg Wheel.** The Engineer may perform a Hamburg Wheel on plant produced mixture at any time during production. In addition to testing production samples, the Engineer may obtain cores and perform the Hamburg Wheel test on any area of the roadway where rutting is observed. Suspend production until further Hamburg Wheel meet the specified values when the production or core samples fail to meet the Hamburg Wheel criteria in accordance with Table 7. Core samples, if taken, will be obtained from the center of the finished mat or other areas excluding the vehicle wheel paths. The Engineer may require up to the entire subplot of any mixture failing the Hamburg Wheel to be removed and replaced at the Contractor's expense.

If the Department's or Department-approved laboratory's Hamburg Wheel test results in a "remove and replace" condition, the Contractor may request that the Department confirm the results by re-testing the failing material. The Materials and Tests Division will perform the Hamburg Wheel and determine the final disposition of the material in question based on the Department's test results.

- 4.9.2.5. **Individual Loads of Hot-Mix.** The Engineer can reject individual truckloads of hot-mix. When a load of hot-mix is rejected for reasons other than temperature, contamination, or excessive uncoated particles, the Contractor may request that the rejected load be tested. Make this request within 4 hr. of rejection. The Engineer will sample and test the mixture. If test results are within the operational tolerances in accordance with Table 8, payment will be made for the load. If test results are not within operational tolerances, no payment will be made for the load.

- 4.9.3. **Placement Acceptance.**

- 4.9.3.1. **Placement Lot.** A placement lot consists of four placement sublots. A placement subplot consists of the area placed during a production subplot.

- 4.9.3.1.1. **Recovered Asphalt Dynamic Shear Rheometer (DSR).** The Engineer may take production samples or cores from suspect areas of the project to determine recovered asphalt properties. Asphalt binders with an aging ratio greater than 3.5 do not meet the requirements for recovered asphalt properties and may be deemed defective when tested and evaluated by the Materials and Tests Division. The aging ratio is the DSR value of the extracted binder divided by the DSR value of the original unaged binder. Obtain DSR values in accordance with AASHTO T 315 at the specified high temperature performance grade of the asphalt. The Engineer may require removal and replacement of the defective material at the Contractor's expense. The asphalt binder will be recovered for testing from production samples or cores in accordance with [Tex-211-F](#).

- 4.9.3.1.2. **Irregularities.** Identify and correct irregularities including segregation, rutting, raveling, flushing, fat spots, mat slippage, irregular color, irregular texture, roller marks, tears, gouges, streaks, uncoated aggregate particles, or broken aggregate particles. The Engineer may also identify irregularities, and in such cases, the Engineer will promptly notify the Contractor. The Engineer may require the Contractor to remove and replace (at the

Contractor's expense) areas of the pavement that contain irregularities if the Engineer determines that the irregularity will adversely affect pavement performance. The Engineer may also require the Contractor to remove and replace (at the Contractor's expense) areas where the mixture does not bond to the existing pavement.

The Engineer may require the Contractor to immediately suspend operations if irregularities are detected or may allow the Contractor to continue operations for no more than one day while the Contractor is taking appropriate corrective action.

4.9.4. **Exempt Production.** When the anticipated daily production is less than 100 ton, all QC and QA sampling and testing are waived. The Engineer may deem the mixture as exempt production for the following conditions:

- anticipated daily production is more than 100 ton but less than 250 ton;
- total production for the project is less than 2,500 ton;
- when mutually agreed between the Engineer and the Contractor; or
- when shown on the plans.

For exempt production, the Contractor is relieved of all production and placement sampling and testing requirements. All other specification requirements apply, and the Engineer will perform acceptance tests for production and placement in accordance with Table 13.

For exempt production:

- produce, haul, place, and compact the mixture as directed by the Engineer; and
- control mixture production to yield a laboratory-molded density that is within $\pm 1.0\%$ of the target density as tested by the Engineer.

4.9.5. **Ride Quality.** Measure ride quality in accordance with Item 585, "Ride Quality for Pavement Surfaces," unless otherwise shown on the plans.

5. MEASUREMENT

5.1. **TOM Hot-Mix Asphalt.** TOM hot-mix will be measured by the ton of composite mixture, which includes asphalt, aggregate, and additives. Measure the weight on scales in accordance with Item 520, "Weighing and Measuring Equipment."

5.2. **Tack Coat.** Tack coat will be measured at the applied temperature by strapping the tank before and after road application and determining the net volume in gallons from the calibrated distributor. The Engineer will witness all strapping operations for volume determination. All tack, including emulsions, will be measured by the gallon applied.

The Engineer may allow the use of a metering device to determine asphalt volume used and application rate if the device is accurate within 1.5% of the strapped volume.

6. PAYMENT

The work performed and materials furnished in accordance with this Item and measured as provided under Section 3081.5.1., "TOM Hot-Mix Asphalt," will be paid for at the unit bid price for "Thin Overlay Mixture" of the mixture type, SAC, and binder specified. These prices are full compensation for surface preparation, removing pavement marking and markers, materials, placement, equipment, labor, tools, and incidentals.

The work performed and materials furnished in accordance with this Item and measured as provided under Section 3081.5.2., "Tack Coat," will be paid for at the unit bid price for "Tack Coat" of the tack coat provided. These prices are full compensation for materials, placement, equipment, labor, tools, and incidentals.

Trial batches will not be paid for unless they are included in pavement work approved by the Department.

Payment adjustment for ride quality will be determined in accordance with Item 585, "Ride Quality for Pavement Surfaces."

Special Specification 3082

Thin Bonded Friction Courses



1. DESCRIPTION

Construct a hot-mix asphalt (HMA) surface course composed of a warm spray-applied polymer modified emulsion membrane followed immediately with a compacted permeable mixture of aggregate, asphalt binder, and additives mixed hot in a mixing plant.

2. MATERIALS

Furnish uncontaminated materials of uniform quality that meet the requirements of the plans and specifications.

Notify the Engineer of all material sources and before changing any material source or formulation. The Engineer will verify that the specification requirements are met when the Contractor makes a source or formulation change, and may require a new laboratory mixture design, trial batch, or both. The Engineer may sample and test project materials at any time during the project to verify specification compliance in accordance with Item 6, “**Control of Materials.**”

2.1. Aggregate. Furnish aggregates from sources that conform to the requirements shown in Table 1 and as specified in this Section. Aggregate requirements in this Section, including those shown in Table 1, may be modified or eliminated when shown on the plans. Additional aggregate requirements may be specified when shown on the plans. Provide aggregate stockpiles that meet the definitions in this Section for coarse or fine aggregate. Do not use intermediate or fine aggregate in PFC mixtures. Supply aggregates that meet the definitions in [Tex-100-E](#) for crushed gravel or crushed stone. The Engineer will designate the plant or the quarry as the sampling location. Provide samples from materials produced for the project. The Engineer will establish the Surface Aggregate Classification (SAC) and perform Los Angeles abrasion, magnesium sulfate soundness, and Micro-Deval tests. Perform all other aggregate quality tests listed in accordance with Table 1. Document all test results on the mixture design report. The Engineer may perform tests on independent or split samples to verify Contractor test results. Stockpile aggregates for each source and type separately. Determine aggregate gradations for mixture design and production testing based on the washed sieve analysis given in [Tex-200-F](#), Part II.

2.1.1. Coarse Aggregate. Coarse aggregate stockpiles must have no more than 20% material passing the No. 8 sieve. Aggregates from sources listed in the **Department's Bituminous Rated Source Quality Catalog (BRSQC)** are preapproved for use. Use only the rated values for hot-mix listed in the BRSQC. Rated values for surface treatment (ST) do not apply to coarse aggregate sources used in hot-mix asphalt.

For sources not listed on the **Department's BRSQC**:

- build an individual stockpile for each material;
- request the Department test the stockpile for specification compliance;
- approved only when tested by the Engineer;
- once approved, do not add material to the stockpile unless otherwise approved; and
- allow 30 calendar days for the Engineer to sample, test, and report results.

Provide coarse aggregate with at least the minimum SAC shown on the plans. SAC requirements only apply to aggregates used on the surface of travel lanes, unless otherwise shown on the plans. SAC requirements apply to aggregates used on surfaces other than travel lanes when shown on the plans. The SAC for sources on the **Department's Aggregate Quality Monitoring Program (AQMP)** ([Tex-499-A](#)) is listed in the BRSQC.

- 2.1.1.1. Blending Class A and Class B Aggregates. To prevent crushing of the Class B aggregate when blending, Class B aggregate may be blended with a Class A aggregate to meet requirements for Class A materials if **the Department's BRSQC rated source soundness magnesium (RSSM) rating for the Class B aggregate is less than the Class A aggregate or if the RSSM rating for the Class B aggregate is less than or equal to 10%**. Use the rated values for hot mix asphaltic concrete (HMAC) published in the BRSQC. When blending Class A and B aggregates to meet a Class A requirement, ensure that at least 50% by weight, or volume if required, of all the aggregates used in the mixture design retained on the No. 4 sieve comes from the Class A aggregate source, unless otherwise shown on the plans. Blend by volume if the bulk specific gravities of the Class A and B aggregates differ by more than 0.300. Class B aggregate may be disallowed when shown on the plans.

The Engineer may perform tests at any time during production, when the Contractor blends Class A and B aggregates to meet a Class A requirement, to ensure that at least 50% by weight, or volume if required, of the material retained on the No. 4 sieve comes from the Class A aggregate source. The Engineer will use the **Department's** mix design template, when electing to verify conformance, to calculate the percent of Class A aggregate retained on the No. 4 sieve by inputting the bin percentages shown from readouts in the control room at the time of production and stockpile gradations measured at the time of production. The Engineer may determine the gradations based on either washed or dry sieve analysis from samples obtained from individual aggregate cold feed bins or aggregate stockpiles. The Engineer may perform spot checks using the gradations supplied by the Contractor on the mixture design report as an input for the template; however, a failing spot check will require confirmation with a stockpile gradation determined by the Engineer.

- 2.1.1.2. Micro-Deval Abrasion. The Engineer will perform a minimum of one Micro-Deval abrasion test in accordance with [Tex-461-A](#) for each coarse aggregate source used in the mixture design that has a Rated Source Soundness Magnesium (RSSM) loss value greater than 15 as listed in the BRSQC, unless otherwise directed. The Engineer will perform testing before the start of production and may perform additional testing at any time during production. The Engineer may obtain the coarse aggregate samples from each coarse aggregate source or may require the Contractor to obtain the samples. The Engineer may waive all Micro-Deval testing based on a satisfactory test history of the same aggregate source.

The Engineer will estimate the magnesium sulfate soundness loss for each coarse aggregate source, when tested, using the following formula:

$$Mg_{est.} = (RSSM)(MD_{act.}/RSMD)$$

where:

$Mg_{est.}$ = magnesium sulfate soundness loss

$RSSM$ = Rated Source Soundness Magnesium

$MD_{act.}$ = actual Micro-Deval percent loss

$RSMD$ = Rated Source Micro-Deval

When the estimated magnesium sulfate soundness loss is greater than the maximum magnesium sulfate soundness loss specified, the coarse aggregate source will not be allowed for use unless otherwise approved. The Engineer will consult the Soils and Aggregates Section of the Materials and Tests Division, and additional testing may be required before granting approval.

- 2.1.2. Fine Aggregate. Fine aggregates consist of manufactured sands and screenings. Fine aggregate stockpiles must meet the fine aggregate properties in accordance with Table 1 and the gradation requirements in accordance with Table 2. Supply fine aggregates that are free from organic impurities. The Engineer may test the fine aggregate in accordance with [Tex-408-A](#) to verify the material is free from organic impurities. Do not use field sand or other uncrushed fine aggregate. Use fine aggregate from coarse aggregate sources that meet the requirements shown in accordance with Table 1 unless otherwise approved.

Table 1
Coarse Aggregate Quality Requirements

Property	Test Method	Requirement
SAC	Tex-499-A (AQMP)	As shown on the plans
Deleterious material, %, Max	Tex-217-E, Part I	1.0
Decantation, %, Max	Tex-217-E, Part II	1.5
Micro-Deval abrasion, %	Tex-461-A	Note ¹
Los Angeles abrasion, %, Max	Tex-410-A	30
Magnesium sulfate soundness, 5 cycles, %, Max	Tex-411-A	20
Crushed face count ² , %, Min	Tex-460-A, Part I	95
Flat and elongated particles @ 5:1, %, Max	Tex-280-F	10
Fine Aggregate Properties		
Sand Equivalent, %, Min	Tex-203-F	45
Methylene Blue, mg/g, Max	Tex-252-F	10.0

1. **Used to estimate the magnesium sulfate soundness loss in accordance with section 3082.2.1.1.2., "Micro-Deval Abrasion."**
2. Only applies to crushed gravel.

Table 2
Gradation Requirements for Fine Aggregate

Sieve Size	% Passing by Weight or Volume
3/8"	100
#8	70–100
#200	0–30

- 2.2. Mineral Filler. Mineral filler consists of finely divided mineral matter such as agricultural lime, crusher fines, or hydrated lime. Fly ash is not allowed unless otherwise shown on the plans. Mineral filler is allowed unless otherwise shown on the plans. Use no more than 2% hydrated lime, unless otherwise shown on the plans. Test all mineral fillers except hydrated lime and fly ash in accordance with [Tex-252-F](#) to ensure specification compliance. The plans may require or disallow specific mineral fillers. Provide mineral filler, when used, that:
- is sufficiently dry, free-flowing, and free from clumps and foreign matter as determined by the Engineer;
 - does not exceed 3% linear shrinkage when tested in accordance with [Tex-107-E](#); and
 - meets the gradation requirements in accordance with Table 3, unless otherwise shown on the plans.

Table 3
Gradation Requirements for Mineral Filler

Sieve Size	% Passing by Weight or Volume
#8	100
#200	55–100

- 2.3. Baghouse Fines. Fines collected by the baghouse or other dust-collecting equipment may be reintroduced into the mixing drum.
- 2.4. Asphalt Binder. Furnish the type and grade of binder specified on the plans that meets the requirements of Item 300, "**Asphalts, Oils, and Emulsions.**"
- 2.4.1. Performance-Graded (PG) Binder. Provide an asphalt binder with a high-temperature grade of PG 76 and low-temperature grade as shown on the plans in accordance with Section 300.2.10., "**Performance-Graded Binders,**" when PG binder is specified.
- 2.4.2. Asphalt-Rubber (A-R) Binder. Provide A-R binder that meets the Type I or Type II requirements of Section 300.2.9., "**Asphalt-Rubber Binders,**" when A-R is specified unless otherwise shown on the plans. Use at least 15.0% by weight of Crumb Rubber Modifier (CRM) that meets the Grade B or Grade C requirements of Section 300.2.7., "**Crumb Rubber Modifier,**" unless otherwise shown on the plans. Provide the Engineer the A-R binder blend design with the mix design (JMF1) submittal. Provide the Engineer with documentation such as the bill of lading showing the quantity of CRM used in the project unless otherwise directed.
- 2.5. Membrane. Provide a smooth and homogeneous polymer modified emulsion meeting the requirements in accordance with Table 4.

Table 4
Polymer Modified Emulsion Requirements

Test on Emulsion	Test Method	Min	Max
Viscosity @ 77°F, SSF	T 72	20	100
Storage Stability, ¹ %	T 59		1
Demulsibility (for anionic emulsions), 35 mL of 0.02 N CaCl ₂ , %	T 59	55	
Demulsibility (for cationic emulsions), 35 mL 0.8% Sodium dioctyl sulfosuccinate, %	T 59	55	
Sieve Test, ² %	T 59		0.05
Distillation Test: ³			
Residue by distillation, % by wt.	T 59	63	0.5
Oil portion of distillate, % by vol.			
Test on Residue from Distillation	Test Method	Min	Max
Elastic Recovery @ 50°F, 50 mm/min., %	Tex-539-C	60	
Penetration @ 77°F, 100 g, 5 sec, 0.1 mm	T 49	100	150

1. After standing undisturbed for 24 hr., the surface must be smooth, must not exhibit a white or milky colored substance, and must be a homogeneous color throughout.
2. May be required by the Engineer only when the emulsion cannot be easily applied in the field.
3. The temperature on the lower thermometer should be brought slowly to 350°F ±10°F and maintained at this temperature for 20 min. The total distillation should be complete in 60 ±5 min. from the first application of heat.

2.6. Additives. Provide the Engineer with documentation such as the bill of lading showing the quantity of additives used in the project unless otherwise directed.

2.6.1. Fibers. Provide cellulose or mineral fibers when PG binder is specified. Do not use fibers when A-R binder is specified. Submit written certification to the Engineer that the fibers proposed for use meet the requirements of DMS-9204, "**Fiber Additives for Bituminous Mixtures.**" Fibers may be pre-blended into the binder at the asphalt supply terminal unless otherwise shown on the plans.

2.6.2. Lime Mineral Filler. Add lime as mineral filler at a rate of 1.0% by weight of the total dry aggregate in accordance with Item 301, "**Asphalt Antistripping Agents,**" unless otherwise shown on the plans or waived by the Engineer based on Hamburg Wheel test results. Do not add lime directly into the mixing drum of any plant where lime is removed through the exhaust stream unless the plant has a baghouse or dust collection system that reintroduces the lime into the drum.

2.6.3. Lime and Liquid Antistripping Agent. When lime or a liquid antistripping agent is used, add in accordance with Item 301, "**Asphalt Antistripping Agents.**" Do not add lime directly into the mixing drum of any plant where lime is removed through the exhaust stream unless the plant has a baghouse or dust collection system that reintroduces the lime into the drum. Lime added as mineral filler will count towards the total quantity of lime specified when the plans require lime to be added as an antistripping agent.

2.6.4. Compaction Aid. Compaction Aid is defined as a Department-approved chemical warm mix additive denoted as "**chemical additive**" on the Department's material producer list (MPL) that is used to facilitate mixing and compaction of HMA.

Compaction aid is allowed for use on all projects. Compaction aid is required when shown on the plans or as required in Section 3082.4.7.1., "Weather Conditions."

Warm mix foaming processes, denoted as "foaming process" on the Department-approved MPL, may be used to facilitate mixing and compaction of HMA; however warm mix processes are not defined as a Compaction Aid.

2.7. Recycled Materials. Recycled materials are not allowed for use.

3. EQUIPMENT

Provide required or necessary equipment in accordance with Item 320, “Equipment for Asphalt Concrete Pavement.” When A-R binder is specified, equip the hot-mix plant with an in-line viscosity-measuring device located between the blending unit and the mixing drum. Provide a means to calibrate the asphalt mass flow meter on-site when a meter is used.

3.1. Placement Equipment. Provide a paver that meets all the requirements listed below.

3.1.1. Paver. Furnish a paver that will spray the membrane, apply the PFC mixture, and level the surface of the mat in a single pass. Configure the paver so that the mixture is placed no more than 5 sec. after the membrane is applied. Ensure the paver does not support the weight of any portion of hauling equipment other than the connection. Provide loading equipment that does not transmit vibrations or other motions to the paver that adversely affects the finished pavement quality. Equip the paver with an automatic dual longitudinal-grade control system and an automatic transverse-grade control system.

3.1.1.1. Tractor Unit. Supply a tractor unit that can push or propel vehicles, dumping directly into the finishing machine to obtain the desired lines and grades to eliminate any hand finishing. Equip the unit with a hitch to maintain contact between the hauling **equipment's** rear wheels and the finishing **machine's** pusher rollers while mixture is unloaded.

3.1.1.2. Membrane Storage Tank and Distribution System. Equip the paver with an insulated storage tank with a minimum capacity of 900 gal. Provide a metered mechanical pressure sprayer on the paver to apply a uniform membrane at the specified rate. Locate the spray bar on the paver so that the membrane is applied immediately in front of the screed unit. Provide a read-out device on the paver to monitor the membrane application rate.

Furnish a volumetric calibration and strap stick for the tank in accordance with [Tex-922-K](#), Part I, unless otherwise directed. Calibrate the tank within the previous 5 yr. of the date first used on the project. The Engineer may verify calibration accuracy in accordance with [Tex-922-K](#), Part II.

3.1.1.3. Screed. Provide a variable width vibratory screed that meets Item 320, “**Equipment for Asphalt Concrete Pavement.**”

3.1.2. Material Transfer Device (MTD). Provide the specified type of MTD when shown on the plans. Ensure MTDs provide a continuous, uniform mixture flow to the asphalt paver.

3.1.3. Rollers. Provide steel-wheel rollers meeting the requirements of Item 210, “**Rolling,**” except provide rollers weighing a minimum of 10 ton for each roller required. Operate rollers in static (non-vibrating) mode unless otherwise allowed.

4. CONSTRUCTION

Produce, haul, place, and compact the specified paving mixture. In addition to tests required by the specification, Contractors may perform other QC tests as deemed necessary. At any time during the project, the Engineer may perform production and placement tests as deemed necessary in accordance with Item 5, “**Control of the Work.**” Schedule and participate in a mandatory pre-paving meeting with the Engineer on or before the first day of paving unless otherwise shown on the plans.

4.1. Certification. Personnel certified by the Department-approved hot-mix asphalt certification program must conduct all mixture designs, sampling, and testing in accordance with Table 5. Supply the Engineer with a list of certified personnel and copies of their current certificates before beginning production and when personnel changes are made. Provide a mixture design developed and signed by a Level 2 certified specialist. Provide Level 1A certified specialists at the plant during production operations. Provide Level 1B certified specialists to conduct placement tests. Provide AGG101 certified specialists for aggregate testing.

Table 5

Test Methods, Test Responsibility, and Minimum Certification Levels

Test Description	Test Method	Contractor	Engineer	Level ¹
<i>1. Aggregate Testing</i>				
Sampling	Tex-221-F	✓	✓	1A/AGG101
Dry sieve	Tex-200-F , Part I	✓	✓	1A/AGG101
Washed sieve	Tex-200-F , Part II	✓	✓	1A/AGG101
Deleterious material	Tex-217-F , Parts I & III	✓	✓	AGG101
Decantation	Tex-217-F , Part II	✓	✓	AGG101
Los Angeles abrasion	Tex-410-A		✓	Department
Magnesium sulfate soundness	Tex-411-A		✓	Department
Micro-Deval abrasion	Tex-461-A		✓	AGG101
Crushed face count	Tex-460-A	✓	✓	AGG101
Flat and elongated particles	Tex-280-F	✓	✓	AGG101
Methylene blue test	Tex-252-F		✓	Department
<i>2. Asphalt Binder & Tack Coat Sampling</i>				
Asphalt binder sampling	Tex-500-C , Part II	✓	✓	1A/1B
Membrane sampling	Tex-500-C , Part III	✓	✓	1A/1B
<i>3. Mix Design & Verification</i>				
Design and JMF changes	Tex-204-F	✓	✓	2
Mixing	Tex-205-F	✓	✓	2
Molding (SGC)	Tex-241-F	✓	✓	1A
Laboratory-molded density	Tex-207-F , Parts I, VI, & VIII	✓	✓	1A
Rice gravity	Tex-227-F , Part II	✓	✓	1A
Ignition oven correction factors ²	Tex-236-F , Part II	✓	✓	2
Drain-down	Tex-235-F	✓	✓	1A
Hamburg Wheel test	Tex-242-F	✓	✓	1A
Boil test ⁴	Tex-530-C	✓	✓	1A
Cantabro loss	Tex-245-F	✓	✓	1A
<i>4. Production Testing</i>				
Control charts	Tex-233-F	✓	✓	1A
Mixture sampling	Tex-222-F	✓	✓	1A/1B
Gradation & asphalt binder content ²	Tex-236-F , Part I	✓	✓	1A
Moisture content	Tex-212-F , Part II	✓	✓	1A/AGG101
Micro-Deval abrasion	Tex-461-A		✓	AGG101
Drain-down	Tex-235-F	✓	✓	1A
Boil test ⁴	Tex-530-C	✓	✓	1A
Abson recovery	Tex-211-F		✓	Department
<i>5. Placement Testing</i>				
Control charts	Tex-233-F	✓	✓	1A
Ride quality measurement	Tex-1001-S	✓	✓	Note 3
Thermal profile	Tex-244-F	✓	✓	1B
Water flow test	Tex-246-F	✓	✓	1B

1. Level 1A, 1B, AGG101, and 2 are certification levels provided by the Hot Mix Asphalt Center certification program.
2. Refer to Section 3082.4.5., "Production Operations," for exceptions to using an ignition oven.
3. Profiler and operator are required to be certified at the Texas A&M Transportation Institute facility when Surface Test Type B is specified.
4. When shown on the plans.

4.2.

Reporting and Responsibilities. Use Department-provided templates to record and calculate all test data, including mixture design, production and placement tests, control charts, and thermal profiles. Obtain the current version of the templates at <https://www.txdot.gov/inside-txdot/forms-publications/consultants-contractors/forms/site-manager.html> or from the Engineer. The Engineer and the Contractor will provide any available test results to the other party when requested. The Contractor and Engineer must exchange test data within the maximum allowable time in accordance with Table 6 unless otherwise approved. The Engineer and the

Contractor will immediately report to the other party any test result that requires suspension of production or placement or that fails to meet the specification requirements. Record and electronically submit all test results and pertinent information on Department-provided templates.

Subsequent sublots placed after test results are available to the Contractor, which require suspension of operations, may be considered unauthorized work. Unauthorized work will be accepted or rejected at the discretion of the Engineer in accordance with Section 5.3., “**Conformity with Plans, Specifications, and Special Provisions.**”

Table 6
Reporting Schedule

Description	Reported By	Reported To	To Be Reported Within
<i>Production Quality Control</i>			
Gradation ¹	Contractor	Engineer	1 working day of completion of the subplot
Asphalt binder content ¹			
Laboratory-molded density ¹			
Moisture content ²			
Drain-down ¹			
Boil test ⁴			
<i>Production Quality Assurance</i>			
Gradation ²	Engineer	Contractor	1 working day of completion of the subplot
Asphalt binder content ²			
Laboratory-molded density ²			
Hamburg Wheel test ³			
Boil test ⁴			
Binder tests ³			
<i>Placement Quality Control</i>			
Thermal profile ¹	Contractor	Engineer	1 working day of completion of the lot
Water flow ¹			
Membrane application rate ²			
<i>Placement Quality Assurance</i>			
Thermal profile ²	Engineer	Contractor	1 working day of completion of the lot
Aging ratio ³			
Water flow ²			
Membrane application rate ²			

1. These tests are required on every subplot.
2. To be performed at the frequency in accordance with Table 14 or as shown on the plans.
3. To be reported as soon as the results become available.
4. When shown on the plans

Use the procedures described in [Tex-233-F](#), when directed, to plot the results of all production and placement testing. Update the control charts as soon as test results for each subplot become available. Make the control charts readily accessible at the field laboratory. The Engineer may suspend production for failure to update control charts.

- 4.3. Quality Control Plan (QCP). Develop and follow the QCP in detail. Obtain approval for changes to the QCP made during the project. The Engineer may suspend operations if the Contractor fails to comply with the QCP.

Submit a written QCP before the mandatory pre-paving meeting, when directed. Receive approval of the QCP before pre-paving meeting. Include the following items in the QCP:

- 4.3.1. Project Personnel. For project personnel, include:
- a list of individuals responsible for QC with authority to take corrective action;
 - current contact information for each individual listed; and
 - current copies of certification documents for individuals performing specified QC functions.
- 4.3.2. Material Delivery and Storage. For material delivery and storage, include:
- the sequence of material processing, delivery, and minimum quantities to assure continuous plant

operations;

- aggregate stockpiling procedures to avoid contamination and segregation;
- frequency, type, and timing of aggregate stockpile testing to assure conformance of material requirements before mixture production; and
- procedure for monitoring the quality and variability of asphalt binder.

4.3.3. Production. For production, include:

- loader operation procedures to avoid contamination in cold bins;
- procedures for calibrating and controlling cold feeds;
- procedures to eliminate debris or oversized material;
- procedures for adding and verifying rates of each applicable mixture component (e.g., aggregate, asphalt binder, lime, liquid antistripping, compaction aid, foaming process, fibers);
- procedures for reporting job control test results; and
- procedures to avoid segregation and drain-down in the silo.

4.3.4. Loading and Transporting. For loading and transporting, include:

- type and application method for release agents; and
- truck loading procedures to avoid segregation.

4.3.5. Placement and Compaction. For placement and compaction, include:

- proposed agenda for mandatory pre-paving meeting, including date and location;
- proposed paving plan (e.g., production rate, paving widths, joint offsets, and lift thicknesses);
- type and application method for release agents in the paver and on rollers, shovels, lutes, and other utensils;
- procedures for the transfer of mixture into the paver while avoiding physical and thermal segregation and preventing material spillage;
- process to balance production, delivery, paving, and compaction to achieve continuous placement operations and good ride quality;
- paver operations (e.g., speed, operation of wings, height of mixture in auger chamber) to avoid physical and thermal segregation and other surface irregularities; and
- procedures to construct quality longitudinal and transverse joints.

4.4. Mixture Design.

4.4.1. Design Requirements. Use the design procedure provided in [Tex-204-E](#), unless otherwise shown on the plans. Design the mixture to meet the requirements in accordance with Tables 1, 2, 3, 7, 8, and 9. Use a Superpave Gyration Compactor (SGC) at 50 gyrations as the design number of gyrations (N_{design}).

The Engineer will provide the mixture design when shown on the plans. The Contractor may submit a new mixture design at any time during the project. The Engineer will verify and approve all mixture designs (JMF1) before the Contractor can begin production.

Provide the Engineer with a mixture design report using the Department-provided template. Include the following items in the report:

- the combined aggregate gradation, source, specific gravity, and percent of each material used;
- the membrane application rate based on design volumetrics;
- results of all applicable tests;
- the mixing and molding temperatures;
- the signature of the Level 2 person or persons that performed the design;
- the date the mixture design was performed; and
- a unique identification number for the mixture design.

Table 7
Master Gradation Limits (% Passing by Weight or Volume)
and Laboratory Mixture Design Properties

Sieve Size	Permeable Friction Course		Thin Bonded Friction Course		
	Fine (PFC-F)	Coarse (PFC-C and PFCR-C)	Type A	Type B	Type C
3/4"	–	100.0 ¹	–	–	100 ¹
1/2"	100.0 ¹	80.0–100.0	–	100 ¹	75–100
3/8"	95.0–100.0	35.0–60.0	100 ¹	75–100	55–80
#4	20.0–55.0	1.0–20.0	35–55	22–36	22–36
#8	1.0–10.0	1.0–10.0	19–30	19–30	19–30
#16	–	–	14–25	14–24	14–24
#50	–	–	7–14	7–14	7–14
#200	1.0–4.0	1.0–4.0	4–6	4–6	4–6

1. Defined as maximum sieve size. No tolerance allowed.

Table 8
Mixture Design Properties

Mixture Property	Test Method	PG 76 Mixtures		A-R Mixtures	Thin Bonded Friction Course		
		Fine (PFC-F)	Coarse (PFC-C)	Coarse (PFCR-C)	Type A	Type B	Type C
Asphalt binder content, %	–	6.0–7.0	6.0–7.0	7.0–9.0	5.0–5.8	4.8–5.6	4.8–5.6
Film thickness, microns	–	–	–	–	9.0 Min	9.0 Min	9.0 Min
Design gyrations (N _{design})	Tex-241-F	50	50	50	50	50	50
Laboratory-molded density, %	Tex-207-F	78.0 Max	82.0 Max	82.0 Max	92.0 Max	92.0 Max	92.0 Max
Hamburg Wheel test, ¹ passes at 12.5 mm rut depth	Tex-242-F	10,000 Min	Note 2	Note 2	Note 2	Note 2	Note 2
Drain-down, %	Tex-235-F	0.10 Max	0.10 Max	0.10 Max	0.10 Max	0.10 Max	0.10 Max
Fiber content, % by wt. of total PG 76 mixture	Calculated	0.20–0.50	0.20–0.50	–	–	–	–
Lime content, % by wt. of total aggregate	Calculated	1.0 ³	1.0 ³	–	Note 4	Note 4	Note 4
CRM content, % by wt. of A-R binder	Calculated	–	–	15.0 Min	–	–	–
Boil test ⁵	Tex-530-C	–	–	–	–	–	–
Cantabro loss, %	Tex-245-F	20.0 Max	20.0 Max	20.0 Max	20.0 Max	20.0 Max	20.0 Max

- Mold test specimens to N_{design} at the optimum asphalt binder content.
- No specification value is required unless otherwise shown on the plans.
- Unless otherwise shown on the plans or waived by the Engineer based on Hamburg Wheel results.
- Lime may be required when shown on the plans.
- When shown on the plans. Used to establish baseline for comparison to production results.

4.4.2. Job-Mix Formula Approval. The job-mix formula (JMF) is the combined aggregate gradation, N_{design} level, and target asphalt percentage used to establish target values for hot-mix production. JMF1 is the original laboratory mixture design used to produce the trial batch. When a compaction aid or foaming process is used, JMF1 may be designed and submitted to the Engineer without including the compaction aid or foaming process. When a compaction aid or foaming process is used, document the compaction aid or foaming process used and recommended rate on the JMF1 submittal. The Engineer and the Contractor will verify JMF1 based on plant-produced mixture from the trial batch unless otherwise approved. The Engineer may accept an existing mixture design previously used on a Department project and may waive the trial batch to verify JMF1. The Department may require the Contractor to reimburse the Department for verification tests if more than two trial batches per design are required.

4.4.2.1. **Contractor's** Responsibilities.

4.4.2.1.1. Providing Superpave Gyratory Compactor. Furnish an SGC calibrated in accordance with [Tex-241-F](#) for molding production samples. Locate the SGC at the **Engineer's** field laboratory or make the SGC available to the Engineer for use in molding production samples.

4.4.2.1.2. Gyratory Compactor Correlation Factors. Use [Tex-206-F](#), Part II, to perform a gyratory compactor

correlation when the Engineer uses a different SGC. Apply the correlation factor to all subsequent production test results.

- 4.4.2.1.3. Submitting JMF1. Furnish a mix design report (JMF1) with representative samples of all component materials and request approval to produce the trial batch. Provide an additional 25 lb. of the design mixture if opting to have the Department perform the Hamburg Wheel test on the laboratory mixture when required in accordance with Table 8, and request that the Department perform the test.
- 4.4.2.1.4. Supplying Aggregates. Provide approximately 40 lb. of each aggregate stockpile unless otherwise directed.
- 4.4.2.1.5. Supplying Asphalt. Provide at least 1 gal. of the asphalt material and enough quantities of any additives proposed for use.
- 4.4.2.1.6. Ignition Oven Correction Factors. Determine the aggregate and asphalt correction factors from the ignition oven in accordance with [Tex-236-F](#), Part II. Provide correction factors that are not more than 12 mo. old. Note that the asphalt content correction factor takes into account the percent fibers in the mixture so that the fibers are excluded from the binder content determination. Provide the Engineer with split samples of the mixtures before the trial batch production, including all additives (except water), and blank samples used to determine the correction factors for the ignition oven used for quality assurance testing during production. Correction factors established from a previously approved mixture design may be used for the current mixture design if the mixture design and ignition oven are the same as previously used and the correction factors are not more than 12 mo. old, unless otherwise directed.
- 4.4.2.1.7. Boil Test. When shown on the plans, perform the test and retain the tested sample from [Tex-530-C](#) until completion of the project or as directed. Use this sample for comparison purposes during production. Add lime or liquid antistripping agent as directed if signs of stripping exist.
- 4.4.2.1.8. Trial Batch Production. Provide a plant-produced trial batch upon receiving conditional approval of JMF1 and authorization to produce a trial batch, including the compaction aid or foaming process, if applicable, for verification testing of JMF1 and development of JMF2. Produce a trial batch mixture that meets the requirements in accordance with Table 9. The Engineer may accept test results from recent production of the same mixture instead of a new trial batch.
- 4.4.2.1.9. Trial Batch Production Equipment. Use only equipment and materials proposed for use on the project to produce the trial batch. Provide documentation to verify the calibration or accuracy of the asphalt mass flow meter to measure the binder content. Verify that asphalt mass flow meter meets the requirements of 0.4 % accuracy, when required, in accordance with Item 520, "**Weighing and Measuring Equipment.**" The Engineer may require that the accuracy of the mass flow meter be verified based on quantities used.
- 4.4.2.1.10. Trial Batch Quantity. Produce enough quantity of the trial batch to ensure that the mixture meets the specification requirements.
- 4.4.2.1.11. Number of Trial Batches. Produce trial batches as necessary to obtain a mixture that meets the specification requirements.
- 4.4.2.1.12. Trial Batch Sampling. Obtain a representative sample of the trial batch and split it into three equal portions in accordance with [Tex-222-F](#). Label these portions as "**Contractor,**" "**Engineer,**" and "**Referee.**" Deliver samples to the appropriate laboratory as directed.
- 4.4.2.1.13. Trial Batch Testing. Test the trial batch to ensure the mixture produced using the proposed JMF1 meets the mixture requirements in accordance with Table 9. Ensure the trial batch mixture is also in compliance with the requirements in accordance with Tables 7 and 8. Use a Department-approved laboratory listed on the MPL to perform the Hamburg Wheel test on the trial batch mixture or request that the Department perform the Hamburg Wheel test. The Engineer will be allowed 10 working days to provide the Contractor with Hamburg Wheel test results on the trial batch. Provide the Engineer with a copy of the trial batch test results.
- 4.4.2.1.14. Development of JMF2. Evaluate the trial batch test results, determine the target mixture proportions, and

submit as JMF2 after the Engineer grants full approval of JMF1 based on results from the trial batch. Verify that JMF2 meets the mixture requirements in accordance with Table 9.

- 4.4.2.1.15. Mixture Production. After receiving approval for JMF2, use JMF2 to produce Lot 1.
- 4.4.2.1.16. Development of JMF3. Evaluate the test results from Lot 1, determine the optimum mixture proportions, and submit as JMF3 for use in Lot 2.
- 4.4.2.1.17. JMF Adjustments. If JMF adjustments are necessary to achieve the specified requirements, make the adjustments before beginning a new lot. The adjusted JMF must:
- be provided to the Engineer in writing before the start of a new lot;
 - be numbered in sequence to the previous JMF;
 - meet the master gradation limits in accordance with Table 7
 - meet the binder content limits in accordance with Table 8; and
 - be within the operational tolerances of JMF2 in accordance with Table 9.
- 4.4.2.1.18. Requesting Referee Testing. Use referee testing, if needed, in accordance with Section 3082.4.9.1., “**Referee Testing**,” to resolve testing differences with the Engineer.

Table 9
Operational Tolerances

Test Description	Test Method	Allowable Difference between JMF2 and JMF1 Target ¹	Allowable Difference from Current JMF and JMF2 ²	Allowable Difference between Contractor and Engineer ³
Individual % retained for sieve sized larger than #200	Tex-200-F	Must be Within Master Grading Limits in accordance with Table 7	±3.0 ⁴	±5.0 ⁴
% passing the #200 sieve			±2.0 ⁴	±3.0 ⁴
Laboratory-molded density, %	Tex-207-F , Part VIII	±1.0	±1.0	±1.0
Asphalt binder content, %	Tex-236-F , Part I ⁵	±0.3 ^{6,7}	±0.3 ^{4,6,7}	±0.3 ^{6,7}
Drain-down, %	Tex-235-F	Note 8	Note 8	N/A
Boil test	Tex-530-C	Note 9	Note 9	N/A
Membrane application rate	Tex-247-F	±0.02	±0.02	N/A

1. JMF1 is the approved laboratory mixture design used for producing the trial batch. JMF2 is the approved mixture design developed from the trial batch used to produce Lot 1.
2. Current JMF is JMF3 or higher. JMF3 is the approved mixture design used to produce Lot 2.
3. Contractor may request referee testing only when values exceed these tolerances.
4. Only applies to mixture produced for Lot 1 and higher. Aggregate gradation is not allowed to be outside the limits in accordance with Table 7.
5. Ensure the binder content determination excludes fibers.
6. May be obtained from asphalt mass flow meter readouts as determined by the Engineer.
7. Binder content is not allowed to be outside the limits shown in Table 8.
8. Verify that Table 8 requirements are met.
9. When shown on the plans.

4.4.2.2. **Engineer’s** Responsibilities.

- 4.4.2.2.1. Superpave Gyratory Compactor. The Engineer will use a Department SGC calibrated in accordance with [Tex-241-F](#) to mold samples for laboratory mixture design verification. For molding trial batch and production specimens, the Engineer will use the Contractor-provided SGC at the field laboratory or provide and use a Department SGC at an alternate location.
- 4.4.2.2.2. Conditional Approval of JMF1 and Authorizing Trial Batch. The Engineer will review and verify conformance of the following information within two working days of receipt:

- the **Contractor's** mix design report (JMF1);
- the Contractor-provided Hamburg Wheel test results, if applicable;
- all required materials including aggregates, asphalt, and additives; and
- the mixture specifications.

The Engineer will grant the Contractor conditional approval of JMF1 if the information provided on the paper copy of JMF1 indicates that the **Contractor's** mixture design meets the specifications. When the Contractor does not provide Hamburg Wheel test with laboratory mixture design, 10 working days are allowed for conditional approval of JMF1. The Engineer will base full approval of JMF1 on the test results on mixture from the trial batch.

Unless waived, the Engineer will determine the Micro-Deval abrasion loss in accordance with

Section 3082.2.1.1.2., "Micro-Deval **Abrasion.**" If the **Engineer's** test results are pending after two working days, conditional approval of JMF1 will still be granted within two working days of receiving JMF1. When the **Engineer's** test results become available, they will be used for specification compliance.

The Contractor is authorized to produce a trial batch after the Engineer grants conditional approval of JMF1.

4.4.2.2.3. Hamburg Wheel Testing. At the **Contractor's** request, the Department will perform the Hamburg Wheel test on the laboratory mixture in accordance with [Tex-242-F](#) to verify compliance with the Hamburg Wheel test requirement in accordance with Table 8. The Engineer will be allowed 10 working days to provide the Contractor with Hamburg Wheel results on the laboratory mixture design.

4.4.2.2.4. Ignition Oven Correction Factors. The Engineer will use the split samples provided by the Contractor to determine the aggregate and asphalt correction factors for the ignition oven used for quality assurance testing during production in accordance with [Tex-236-F](#), Part II. Provide correction factors that are not more than 12 mo. old. The Engineer will verify that the asphalt content correction factor takes into account the percent fibers in the mixture so that the fibers are excluded from the binder content determination.

4.4.2.2.5. Testing the Trial Batch. The Engineer will sample and test the trial batch within one full working day to ensure that the mixture meets the requirements in accordance with Table 9. If the Contractor requests the option to have the Department perform the Hamburg Wheel test on the trial batch mixture, the Engineer will mold samples in accordance with [Tex-242-F](#) to verify compliance with the Hamburg Wheel test requirement in accordance with Table 8.

The Engineer will have the option to perform [Tex-530-C](#) on the trial batch when shown on the plans. These results may be retained and used for comparison purposes during production.

4.4.2.2.6. Full Approval of JMF1. The Engineer will grant full approval of JMF1 and authorize the Contractor to proceed with developing JMF2 if the **Engineer's** results for the trial batch meet the requirements in accordance with Tables 7 and 8.

The Engineer will notify the Contractor that an additional trial batch is required if the trial batch does not meet these requirements.

4.4.2.2.7. Approval of JMF2. The Engineer will approve JMF2 within one working day if the mixture meets the requirements in accordance with Tables 7, 8, and 9.

4.4.2.2.8. Approval of Lot 1 Production. The Engineer will authorize the Contractor to proceed with Lot 1 production (using JMF2).

4.4.2.2.9. Approval of JMF3 and Subsequent JMF Changes. JMF3 and subsequent JMF changes are approved if they meet the master grading and asphalt binder content shown in accordance with Tables 7 and 8 and are within the operational tolerances of JMF2 in accordance with Table 9.

- 4.4.2.2.10. Binder Content Adjustments. For JMF2 and above, the Engineer may require the Contractor to adjust the target binder content by no more than 0.3% from the current JMF.
- 4.5. Production Operations. Perform a new trial batch when the plant or plant location is changed. Take corrective action and receive approval to proceed after any production suspension for noncompliance to the specification.
- 4.5.1. Storage and Heating of Materials. Do not heat the asphalt binder above the temperatures specified in Item 300, “**Asphalts, Oils, and Emulsions,**” or outside the **manufacturer’s** recommended values. Provide the Engineer with daily records of asphalt binder and hot-mix asphalt discharge temperatures (in legible and discernible increments) in accordance with Item 320, “**Equipment for Asphalt Concrete Pavement,**” unless otherwise directed. Do not store mixture for a period long enough to affect the quality of the mixture, nor in any case longer than 12 hr. unless otherwise approved.
- 4.5.2. Mixing and Discharge of Materials. Notify the Engineer of the target discharge temperature and produce the mixture within 25°F of the target. Monitor the temperature of the material in the truck before shipping to ensure that it does not exceed the maximum production temperatures in accordance with Table 10. The Department will not pay for or allow placement of any mixture produced above the maximum production temperatures in accordance with Table 10.

Table 10
Maximum Production Temperature

High-Temperature Binder Grade ¹	Max Production Temperature
PG 76	345°F
A-R Binder	345°F

1. The high-temperature binder grade refers to the high-temperature grade of the virgin asphalt binder used to produce the mixture.

Control the mixing time and temperature so that substantially all moisture is removed from the mixture before discharging from the plant. Determine the moisture content, if requested, by oven-drying in accordance with [Tex-212-F](#), Part II, and verify that the mixture contains no more than 0.2% of moisture by weight. Obtain the sample immediately after discharging the mixture into the truck and perform the test promptly.

- 4.6. Hauling Operations. Clean all truck beds before use to ensure that mixture is not contaminated. Use a release agent shown on the **Department’s** MPL to coat the inside bed of the truck when necessary. **Do not use diesel or any release agent not shown on the Department’s MPL.**
- Use equipment for hauling as defined in Section 3082.4.7.3.2., “**Hauling Equipment.**” Use other hauling equipment only when allowed.
- 4.7. Placement Operations. Collect haul tickets from each load of mixture delivered to the project and provide the **Department’s** copy to the Engineer approximately every hour, or as directed. Use a hand-held thermal camera or infrared thermometer, when a thermal imaging system is not used, to measure and record the internal temperature of the mixture as discharged from the truck or Material Transfer Device (MTD) before or as the mix enters the paver and an approximate station number or GPS coordinates on each ticket. Calculate the daily yield and cumulative yield for the specified lift and provide to the Engineer at the end of paving operations for each day unless otherwise directed. The Engineer may suspend production if the Contractor fails to produce and provide haul tickets and yield calculations by the end of paving operations for each day.

Prepare the surface by removing raised pavement markers and objectionable material such as moisture, dirt, sand, leaves, and other loose impediments from the surface before placing mixture. Remove vegetation from pavement edges. Do not allow any loose mixture onto the prepared surface before application of the membrane. Place the mixture to meet the typical section requirements and produce a smooth, finished surface with a uniform appearance and texture. Offset longitudinal joints of successive courses of hot-mix by at least 6 in. Place mixture so that longitudinal joints on the surface course coincide within 6-in. of lane lines and are not placed in the wheel path, or as directed, and offset longitudinal joints of successive courses of hot-mix by at least 6-in. Ensure that all finished surfaces will drain properly.

4.7.1. Weather Conditions.

4.7.1.1. When Using a Thermal Imaging System. The Contractor may pave any time the roadway is dry and the roadway surface temperature is at least 60°F unless otherwise approved or as shown on the plans; however, the Engineer may restrict the Contractor from paving if the ambient temperature is likely to drop below 32°F within 12 hr. of paving. Place mixtures when weather conditions and moisture conditions of the roadway surface are suitable as determined by the Engineer. Provide output data from the thermal imaging system to demonstrate to the Engineer that no recurring severe thermal segregation exists in accordance with Section 3082.4.7.3.1.2., “**Thermal Imaging System.**”

Produce mixture with a target discharge temperature higher than 300°F and with a compaction aid to facilitate compaction when the air temperature is 70°F and falling.

4.7.1.2. When Not Using a Thermal Imaging System. When using a thermal camera instead of the thermal imaging system, place mixture when the roadway surface temperature is at or above 70°F unless otherwise approved or as shown on the plans. Measure the roadway surface temperature with a hand-held thermal camera or infrared thermometer. Place mixtures only when weather conditions and moisture conditions of the roadway surface are suitable as determined by the Engineer. The Engineer may restrict the Contractor from paving if the air temperature is 60°F and falling.

Produce mixture with a target discharge temperature higher than 300°F and with a compaction aid to facilitate compaction when the air temperature is 70°F and falling.

4.7.2. Application of Membrane. Apply the membrane at the rates in accordance with Table 11 unless otherwise directed. Spray the membrane using a metered mechanical pressure spray bar at a temperature of 140°F to 180°F. Monitor the membrane application rate and make adjustments to the rate when directed. Verify that the spray bar is capable of applying the membrane at a uniform rate across the entire paving width. Apply adequate overlap of the tack coat in the longitudinal direction during placement of the mat to ensure bond of adjacent mats, unless otherwise directed. Unless otherwise directed, avoid tacking the vertical faces of adjacent PFC mats in the longitudinal direction to avoid restricting lateral drainage. Apply tack coat to all transverse joints. Do not let the wheels or other parts of the paving machine contact the freshly applied membrane. Do not dilute the membrane at the terminal, in the field, or at any other location before use. Do not allow any loose mixture onto the prepared surface before application of the membrane.

Table 11
Membrane Application Rate Limits, (Gal. per square yard)

Mix Type	Lift Thickness	Membrane Rate
Permeable Friction Course	1-1/2 in.	0.30–0.33
	1-1/4 in.	0.27–0.30
	1 in.	0.25–0.28
	3/4 in.	0.22–0.25
Thin Bonded Friction Course	3/4 in.	0.17–0.27
	5/8 in.	0.16–0.24
	1/2 in.	0.14–0.20

4.7.2.1. Non-uniform Application of Membrane. Stop application if it is not uniform due to streaking, ridging, pooling, or flowing off the roadway surface. Verify equipment condition including plugged nozzles on the spray bar, operating procedures, application temperature, and material properties. Determine and correct the cause of non-uniform application.

4.7.2.2. Test Strips. The Engineer may perform independent tests to confirm Contractor compliance and may require testing differences or failing results to be resolved before resuming production.

The Engineer may cease operations **and require construction of test strips at the Contractor's expense if any of the following occurs:**

- non-uniformity of application continues after corrective action;
- in three consecutive shots, application rate differs by more than 0.03 gal. per square yard from the rate

- directed; or
- any shot differs by more than 0.05 gal. per square yard from the rate directed.

The Engineer will approve the test strip location. The Engineer may require additional test strips until the membrane application meets specification requirements.

- 4.7.3. Lay-Down Operations. Use the placement temperature in accordance with Table 12 to establish the minimum placement temperature of the mixture delivered to the paving operation.

Table 12
Min Mixture Placement Temperature

High-Temperature Binder Grade ¹	Min Placement Temperature (Before Entering Paving Operation) ^{2,3}
PG 76	280°F
A-R Binder	280°F

1. The high-temperature binder grade refers to the high-temperature grade of the virgin asphalt binder used to produce the mixture.
2. The mixture temperature must be measured using a hand-held thermal camera or infrared thermometer nearest to the point of entry of the paving operation.
3. Minimum placement temperatures may be reduced 10°F if using a compaction aid.

- 4.7.3.1. Thermal Profile. Use a hand-held thermal camera or a thermal imaging system to obtain a continuous thermal profile in accordance with [Tex-244-F](#). Thermal profiles are not applicable in areas described in Section 3082.4.9.8., “**Miscellaneous Areas.**”

- 4.7.3.1.1. Thermal Segregation.

- 4.7.3.1.1.1. Moderate. Any areas that have a temperature differential greater than 25°F, but not exceeding 50°F.

- 4.7.3.1.1.2. Severe. Any areas that have a temperature differential greater than 50°F.

- 4.7.3.1.2. Thermal Imaging System. Review the output results when a thermal imaging system is used, and provide the report described in [Tex-244-F](#) to the Engineer daily unless otherwise directed. Modify the paving process as necessary to eliminate any recurring (moderate or severe) thermal segregation identified by the thermal imaging system.

The Engineer may suspend subsequent paving operations if the Contractor cannot successfully modify the paving process to eliminate recurring severe or moderate thermal segregation.

Provide the Engineer with electronic copies of all daily data files that can be used with the thermal imaging system software to generate temperature profile plots daily or as requested by the Engineer.

- 4.7.3.1.3. Thermal Camera. When using the thermal camera instead of the thermal imaging system, take immediate corrective action to eliminate recurring moderate thermal segregation when a hand-held thermal camera is used. Provide the Engineer with the thermal profile of every subplot within one working day of the completion of each lot. When requested by the Engineer, provide the electronic files generated using the thermal camera. Report the results of each thermal profile in accordance with Section 3082.4.2., “**Reporting and Responsibilities.**” The Engineer will use a hand-held thermal camera to obtain a thermal profile at least once per project unless the thermal imaging system is used. Suspend operations and take immediate corrective action to eliminate severe thermal segregation unless otherwise directed. Resume operations when the Engineer determines that subsequent production will meet the requirements of this Section.

- 4.7.3.2. Hauling Equipment. Use live bottom or end dump trucks to haul and transfer mixture; however, with exception of paving miscellaneous areas, end dump trucks are only allowed when used in conjunction with an MTD with remixing capability or when a thermal imaging system is used unless otherwise allowed.

- 4.7.3.3. Screed Heaters. Turn off screed heaters to prevent overheating of the mat if the paver stops for more than 5 min. The Engineer may evaluate the suspect area in accordance with Section 3082.4.9.9., “**Recovered**

Asphalt Dynamic Shear Rheometer (DSR),” if the screed heater remains on for more than 5 min. while the paver is stopped.

- 4.8. Compaction. Roll the freshly placed mixture with as many steel-wheeled rollers as necessary, operated in static mode, to seat the mixture without excessive breakage of the aggregate and to provide a smooth surface and uniform texture. Do not use pneumatic rollers. Use the control strip method given in [Tex-207-F](#), Part IV, to establish the rolling pattern. Moisten the roller drums thoroughly with a soap and water solution to prevent adhesion. Use only water or an approved release agent on rollers, tamps, and other compaction equipment unless otherwise directed.

For PFC mixtures, use [Tex-246-F](#) to test and verify that the compacted mixture has adequate permeability. Measure the water flow once per subplot at locations directed by the Engineer. The water flow rate should be less than 20 sec. Investigate the cause of the water flow rate test failures and take corrective actions during production and placement to ensure the water flow rate is less than 20 sec. Suspend production if two consecutive water flow rate tests fail unless otherwise approved. Resume production after the Engineer approves changes to production or placement methods.

Complete all compaction operations before the pavement temperature drops below 180°F unless otherwise allowed. The Engineer may allow compaction with a light finish roller operated in static mode for pavement temperatures below 180°F.

Allow the compacted pavement to cool to 160°F or lower before opening to traffic unless otherwise directed. Sprinkle the finished mat with water or limewater, when directed, to expedite opening the roadway to traffic.

- 4.9. Acceptance Plan. Sample and test the hot-mix on a lot and subplot basis.
- 4.9.1. Referee Testing. The Materials and Tests Division is the referee laboratory. The Contractor may request referee testing if the differences between Contractor and Engineer test results exceed the operational tolerances in accordance with Table 9 and the differences cannot be resolved. The Contractor may also request referee testing if the **Engineer's** test results require suspension of production and the **Contractor's** test results are within specification limits. Make the request within five working days after receiving test results and cores from the Engineer. Referee tests will be performed only on the subplot in question and only for the particular tests in question. Allow 10 working days from the time the referee laboratory receives the samples for test results to be reported. The Department may require the Contractor to reimburse the Department for referee tests if more than three referee tests per project are required and the **Engineer's** test results are closer to the referee test results than the **Contractor's** test results.
- 4.9.2. Production Acceptance.
- 4.9.2.1. Production Lot. A production lot consists of four equal sublots. The default quantity for Lot 1 is 1,000 ton; however, when requested by the Contractor, the Engineer may increase the quantity for Lot 1 to no more than 2,000 ton. The Engineer will select subsequent lot sizes based on the anticipated daily production such that approximately three to four sublots are produced each day. The lot size will be between 1,000 ton and 4,000 ton. The Engineer may change the lot size before the Contractor begins any lot.
- 4.9.2.1.1. Incomplete Production Lots. If a lot is begun but cannot be completed, such as on the last day of production or in other circumstances deemed appropriate, the Engineer may close the lot. Close all lots within five working days unless otherwise allowed.
- 4.9.2.2. Production Sampling.
- 4.9.2.2.1. Mixture Sampling. Obtain hot-mix samples from trucks at the plant in accordance with [Tex-222-F](#). The sampler will split each sample into three equal portions in accordance with [Tex-200-F](#) and label these portions as “Contractor,” “Engineer,” and “Referee.” **The Engineer will perform or witness the sample splitting and take immediate possession of the samples labeled “Engineer” and “Referee.” The Engineer will maintain the custody of the samples labeled “Engineer” and “Referee” until the Department's testing is completed.**

- 4.9.2.2.1.1. Random Sample. At the beginning of the project, the Engineer will select random numbers for all production sublots. Determine sample locations in accordance with [Tex-225-F](#). Take one sample for each subplot at the randomly selected location. The Engineer will perform or witness the sampling of production sublots.
- 4.9.2.2.1.2. Blind Sample. **For one subplot per lot, the Engineer will obtain and test a “blind” sample instead of the random sample collected by the Contractor. Test either the “blind” or the random sample; however, referee testing (if applicable) will be based on a comparison of results from the “blind” sample. The location of the Engineer’s “blind” sample will not be disclosed to the Contractor. The Engineer’s “blind” sample may be randomly selected in accordance with [Tex-225-F](#) for any subplot or selected at the discretion of the Engineer. The Engineer will use the Contractor’s split sample for sublots not sampled by the Engineer.**
- 4.9.2.2.2. Informational Hamburg and Overlay Testing. Select one random subplot from Lot 2 or higher for Hamburg and Overlay testing during the first week of production. Obtain and provide the Engineer with approximately 90 lb. of mixture, sampled in accordance with [Tex-222-F](#), in sealed containers, boxes, or bags labeled with the Control-Section-Job (CSJ), mixture type, lot, and subplot number. The Engineer will ship the mixture to the Materials and Tests Division for Hamburg and Overlay testing. Results from these tests will not be used for specification compliance.
- 4.9.2.2.3. Asphalt Binder Sampling. Obtain a 1-qt. (1 gal. for A-R binder) sample of the asphalt binder witness by the Engineer for each lot of mixture produced. The Contractor will notify the Engineer when the sampling will occur. Obtain the sample at approximately the same time the mixture random sample is obtained. Sample from a port located immediately upstream from the mixing drum or pug mill and upstream from the introduction of any additives in accordance with [Tex-500-C](#), Part II. Label the can with the corresponding lot and subplot numbers, producer, producer facility, grade, district, date sampled, and project information including highway and CSJ. The Engineer will retain these samples for one year. The Engineer may also obtain independent samples. If obtaining an independent asphalt binder sample and upon request of the Contractor, the Engineer will split a sample of the asphalt binder with the Contractor.

At least once per project, the Engineer will collect split samples of each binder grade and source used. The Engineer will submit one split sample to the Materials and Tests Division to verify compliance with Item 300, “Asphalts, Oils, and Emulsions” and will retain the other split sample for 1 yr.

- 4.9.2.3. Membrane Sampling. The Engineer will obtain a 1-qt. sample of the polymer modified emulsion for each lot of mixture produced in accordance with [Tex-500-C](#), Part III. The Engineer will notify the Contractor when the sampling will occur and will witness the collection of the sample. Obtain the sample at approximately the same time the mixture random sample is obtained. Label the can with the corresponding lot and subplot numbers, producer, producer facility, grade, district, date sampled, and project information including highway and CSJ. The Engineer will retain these samples for two months.

At least once per project, the Engineer will collect split samples of the polymer modified emulsion. The Engineer will submit one split sample to the Materials and Tests Division to verify compliance with Item 300, “Asphalts, Oils, and Emulsions” and will retain the other split sample for two months. The Engineer may test as often as necessary to ensure the residual of the emulsion is greater than or equal to the specification requirement in Item 300, “Asphalts, Oils, and Emulsions.”

- 4.9.2. Production Testing. The Contractor and Engineer must perform production tests in accordance with Table 13. The Contractor has the option to verify the Engineer’s test results on split samples provided by the Engineer. Determine compliance with operational tolerances in accordance with Table 9 for all sublots.

At any time during production, the Engineer may require the Contractor to verify the following based on quantities used:

- lime content (within $\pm 0.1\%$ of JMF), when PG binder is specified;
- fiber content (within $\pm 0.03\%$ of JMF), when PG binder is specified; and
- CRM content (within $\pm 1.5\%$ of JMF), when A-R binder is specified.

Maintain the in-line measuring device when A-R binder is specified to verify the A-R binder viscosity between

2,500 and 4,000 centipoise at 350°F unless otherwise approved. Record A-R binder viscosity at least once per hour and provide the Engineer with a daily summary unless otherwise directed.

If the aggregate mineralogy is such that [Tex-236-F](#), Part I does not yield reliable results, the Engineer may allow alternate methods for determining the asphalt content and aggregate gradation. The Engineer will require the Contractor to provide evidence that results from [Tex-236-F](#), Part I, are not reliable before permitting an alternate method unless otherwise allowed. Use the applicable test procedure as directed if an alternate test method is allowed.

Table 13
Production and Placement Testing Frequency

Description	Test Method	Min Contractor Testing Frequency	Min Engineer Testing Frequency
Individual % retained for sieve sized larger than #200	Tex-200-F	1 per subplot	1 per 12 sublots
% passing the #200 sieve			
Laboratory-molded density, %	Tex-207-E , Part VIII	1 per subplot	1 per lot
Asphalt binder content ¹ , %	Tex-236-F , Part I ²	1 per subplot	1 per lot
Drain-down, %	Tex-235-F	1 per subplot	1 per 12 sublots
Boil test ³	Tex-530-C	1 per project	1 per project
Membrane application rate	Tex-247-F	1 per lot	1 per 12 sublots
Moisture content	Tex-212-F , Part II	When directed	1 per project
Cantabro loss, %	Tex-245-F	1 per project (sample only)	1 per project
Overlay test	Tex-248-F	1 per project (sample only) ¹⁰	1 per project ⁴
Hamburg Wheel test	Tex-242-F	1 per project (sample only) ¹⁰	1 per project ⁴
Water flow test ⁵	Tex-246-F	1 per subplot	1 per project
Asphalt binder sampling	Tex-500-C , Part II	1 per lot (sample only) ⁶	1 per project
Membrane sampling and testing	Tex-500-C , Part III	N/A	1 per project
Thermal profile	Tex-244-F	1 per subplot ^{7,8,9}	1 per project ⁸

1. May be obtained from asphalt mass flow meter readouts as determined by the Engineer.
2. Ensure the binder content determination excludes fibers.
3. When shown on the plans.
4. When required according to mixture type and requirements in accordance with Table 8.
5. Only required for PFC mixtures.
6. Obtain samples witness by the Engineer. The Engineer will retain these samples for 1 yr.
7. To be performed in the presence of the Engineer when using the thermal camera, unless otherwise approved.
8. Not required when a thermal imaging system is used.
9. When using the thermal imaging system, the test report must include the temperature measurements taken in accordance with [Tex-244-F](#).
10. Testing performed by the Materials and Tests Division for informational purposes only.

4.9.3.

Operational Tolerances. Control the production process within the operational tolerances in accordance with Table 9. Suspend production and placement operations when production or placement test results exceed the tolerances in accordance with Table 9 unless otherwise allowed. The Engineer will allow suspended production to resume when test results or other information indicates the next mixture produced will be within the operational tolerances.

- 4.9.4. Individual Loads of Hot-Mix. The Engineer can reject individual truckloads of hot-mix. When a load of hot-mix is rejected for reasons other than temperature, contamination, or excessive uncoated particles, the Contractor may request that the rejected load be tested. Make this request within 4 hr. of rejection. The Engineer will sample and test the mixture. If test results are within the operational tolerances in accordance with Table 9, payment will be made for the load. If test results are not within operational tolerances, no payment will be made for the load.
- 4.9.5. Placement Acceptance.
- 4.9.6. Placement Lot. A placement lot consists of four placement sublots. A placement subplot consists of the area placed during a production subplot.
- 4.9.7. Miscellaneous Areas. Miscellaneous areas include areas that typically involve significant handwork or discontinuous paving operations such as driveways, mailbox turnouts, crossovers, gores, spot level-up areas, and other similar areas. The specified layer thickness is based on the rate of 90 lb. per square yard for each inch of pavement unless another rate is shown on the plans. Miscellaneous areas are not subject to thermal profiles testing.
- 4.9.8. Recovered Asphalt Dynamic Shear Rheometer (DSR). The Engineer may take production samples or cores from suspect areas of the project to determine recovered asphalt properties. Asphalt binders with an aging ratio greater than 3.5 do not meet the requirements for recovered asphalt properties and may be deemed defective when tested and evaluated by the Materials and Tests Division. The aging ratio is the DSR value of the extracted binder divided by the DSR value of the original unaged binder. Obtain DSR values in accordance with AASHTO T 315 at the specified high temperature performance grade of the asphalt. The Engineer may require removal and replacement of the defective material at the **Contractor's** expense. The asphalt binder will be recovered for testing from production samples or cores in accordance with [Tex-211-F](#).
- 4.9.9. Irregularities. Identify and correct irregularities including segregation, rutting, raveling, flushing, fat spots, mat slippage, irregular color, irregular texture, roller marks, tears, gouges, streaks, uncoated aggregate particles, or broken aggregate particles. The Engineer may also identify irregularities, and in such cases, the Engineer will promptly notify the Contractor. If the Engineer determines that the irregularity will adversely affect pavement performance, the Engineer may require the Contractor to remove and replace (at the **Contractor's** expense) areas of the pavement that contain irregularities. The Engineer may also require the Contractor to **remove and replace (at the Contractor's expense)** areas where the mixture does not bond to the existing pavement.
- If irregularities are detected, the Engineer may require the Contractor to immediately suspend operations or may allow the Contractor to continue operations for no more than one day while the Contractor is taking appropriate corrective action.
- 4.9.10. Exempt Production. When the anticipated daily production is less than 100 ton, all QC and QA sampling and testing are waived. The Engineer may deem the mixture as exempt production for the following conditions:
- anticipated daily production is more than 100 ton but less than 250 ton;
 - total production for the project is less than 2,500 ton;
 - when mutually agreed between the Engineer and the Contractor; or
 - when shown on the plans.
- For exempt production, the Contractor is relieved of all production and placement sampling and testing requirements. All other specification requirements apply, and the Engineer will perform acceptance tests for production and placement in accordance with Table 13.
- For exempt production:
- produce, haul, place, and compact the mixture as directed by the Engineer; and
 - control mixture production to yield a laboratory-molded density that is within $\pm 1.0\%$ of the target density as tested by the Engineer.

- 4.9.11. Ride Quality. Measure ride quality in accordance with Item 585, "**Ride Quality for Pavement Surfaces,**" unless otherwise shown on the plans.

5. MEASUREMENT

- 5.1. PFC Hot-Mix Asphalt. Permeable friction course (PFC) hot-mix will be measured by the ton of composite mixture, which includes asphalt, aggregate, and additives. Measure the weight on scales in accordance with Item 520, "**Weighing and Measuring Equipment.**"
- 5.2. TBFC Hot-Mix Asphalt. Thin bonded friction course (TBFC) hot-mix will be measured by the ton of composite mixture, which includes asphalt, aggregate, and additives. Measure the weight on scales in accordance with Item 520, "**Weighing and Measuring Equipment.**"
- 5.3. Membrane. Membrane material will be measured by volume. Membrane material will be measured at the applied temperature by strapping the tank before and after road application and determining the net volume in gallons from the **distributor's** calibrated strap stick. The Engineer will witness all operations for volume determination. All membrane will be measured by the gallon applied, in the accepted membrane.

6. PAYMENT

The work performed and materials furnished in accordance with this Item and measured as provided under Section 3082.5.1., "PFC Hot-Mix Asphalt," will be paid for at the unit bid price for "Permeable friction course" of the mixture type, SAC, and binder specified. These prices are full compensation for surface preparation, removing pavement marking and markers, materials, placement, equipment, labor, tools, and incidentals.

The work performed and materials furnished in accordance with this Item and measured as provided under Section 3082.5.2., "TBFC Hot-Mix Asphalt," will be paid for at the unit bid price for "Thin bonded friction course" **of the mixture type, SAC, and binder** specified. These prices are full compensation for surface preparation, removing pavement marking and markers, materials, placement, equipment, labor, tools, and incidentals.

The work performed and materials furnished in accordance with this Item and measured as provided under Section 3082.5.3., "Membrane," **will be paid for at the unit bid price for "Membrane" of the membrane** material provided. These prices are full compensation for materials, placement, equipment, labor, tools, and incidentals.

Trial batches will not be paid for unless they are included in pavement work approved by the Department.

Payment adjustment for ride quality will be determined in accordance with Item 585, "**Ride Quality for Pavement Surfaces.**"

Special Specification 3096

Asphalts, Oils, and Emulsions



1. DESCRIPTION

Provide asphalt cements, cutback and emulsified asphalts, performance-graded asphalt binders, and other miscellaneous asphalt materials as specified on the plans.

2. MATERIALS

Provide asphalt materials that meet the stated requirements when tested in conformance with the referenced Department, AASHTO, and ASTM test methods. Use asphalt containing recycled materials only if the recycled components meet the requirements of Article 6.9., **"Recycled Materials." Provide asphalt materials** that the Department has preapproved for use in accordance with [Tex-545-C](#), **"Asphalt Binder Quality Program."**

Inform the Department of all additives or modifiers included in the asphalt binder as part of the facility quality plan, as required by [Tex-545-C](#), **"Asphalt Binder Quality Program,"** and provide that information to Department personnel. The Department reserves the right to prohibit the use of any asphalt additive or modifier.

Limit the use of polyphosphoric acid to no more than 0.5% by weight of the asphalt binder.

The use of re-refined engine oil bottoms is prohibited.

Acronyms used in this Item are defined in Table 1.

Table 1
Acronyms

Acronym	Definition
Test Procedure Designations	
Tex T or R D	Department AASHTO ASTM
Polymer Modifier Designations	
P	polymer-modified
SBR or L	styrene-butadiene rubber (latex)
SBS	styrene-butadiene-styrene block co-polymer
TR	tire rubber (from ambient temperature grinding of truck and passenger tires)
AC	asphalt cement
AE	asphalt emulsion
AE-P	asphalt emulsion prime
A-R	asphalt-rubber
C	cationic
EAP&T	emulsified asphalt prime and tack
EBL	emulsified bonding layer
FDR	full depth reclamation
H-suffix	harder residue (lower penetration)
HF	high float
HY	high yield
MC	medium-curing
MS	medium-setting
PCE	prime, cure, and erosion control
PG	performance grade
RC	rapid-curing
RS	rapid-setting
S-suffix	stockpile usage
SCM	special cutback material
SS	slow-setting
SY	standard yield
TRAIL	tracking resistant asphalt interlayer

- 2.1. Asphalt Cement. Provide asphalt cement that is homogeneous, water-free, and nonfoaming when heated to 347°F, and meets the requirements in Table 2.

Table 2
Asphalt Cement

Property	Test Procedure	Viscosity Grade									
		AC-0.6		AC-1.5		AC-3		AC-5		AC-10	
		Min	Max	Min	Max	Min	Max	Min	Max	Min	Max
Viscosity 140°F, poise 275°F, poise	T 202	40	80	100	200	250	350	400	600	800	1,200
		0.4	-	0.7	-	1.1	-	1.4	-	1.9	-
Penetration, 77°F, 100g, 5 sec.	T 49	350	-	250	-	210	-	135	-	85	-
Flash point, C.O.C., °F	T 48	425	-	425	-	425	-	425	-	450	-
Solubility in trichloroethylene, %	T 44	99.0	-	99.0	-	99.0	-	99.0	-	99.0	-
Spot test	Tex-509-C	Neg.		Neg.		Neg.		Neg.		Neg.	
Tests on residue from RTFOT: Viscosity, 140°F, poise Ductility, ¹ 77°F 5 cm/min., cm	T 240										
	T 202	-	180	-	450	-	900	-	1,500	-	3,000
	T 51	100	-	100	-	100	-	100	-	100	-

1. If AC-0.6 or AC-1.5 ductility at 77°F is less than 100 cm, material is acceptable if ductility at 60°F is more than 100 cm.

- 2.2. Polymer-Modified Asphalt Cement. Provide polymer-modified asphalt cement that is smooth, homogeneous, and meets the requirements Table 3. Supply samples of the base asphalt cement and polymer additives if requested.

Table 3
Polymer-Modified Asphalt Cement

Property	Test Procedure	Polymer-Modified Viscosity Grade											
		AC-12-5TR		NT-HA ¹		AC-15P		AC-20XP		AC-10-2TR		AC-20-5TR	
		Min	Max	Min	Max	Min	Max	Min	Max	Min	Max	Min	Max
Polymer		TR		-		SBS		SBS		TR		TR	
Polymer content, % (solids basis)	Tex-533-C or Tex-553-C	5.0	-	-	-	3.0	-	-	-	2.0	-	5.0	-
Dynamic shear, G*/sinδ, 82°C, 10 rad/s, kPa	T 315			1.0	-								
Dynamic shear, G*/sinδ, 64°C, 10 rad/s, kPa	T 315	-	-	-	-	-	-	1.0	-	-	-	1.0	-
Dynamic shear, G*/sinδ, 58°C, 10 rad/s, kPa	T 315	1.0	-	-	-	-	-	-	-	1.0	-	-	-
Viscosity 140°F, poise	T 202	1,200	-			1,500	-	2,000	-	1,000	-	2,000	-
275°F, poise	T 202			-	4,000	-	8.0	-	-	-	8.0	-	10.0
Penetration, 77°F, 100 g, 5 sec.	T 49	110	150	-	25	100	150	75	115	95	130	75	115
Ductility, 5cm/min., 39.2°F, cm	T 51					-	-	-	-	-	-	-	-
Elastic recovery, 50°F, %	Tex-539-C	55	-			55	-	55	-	30	-	55	-
Softening point, °F	T 53	113	-	170	-	-	-	120	-	110	-	120	-
Polymer separation, 5 hr.	Tex-540-C	None				None		None		None		None	
Flash point, C.O.C., °F	T 48	425	-	425	-	425	-	425	-	425	-	425	-
Tests on residue from RTFOT aging and pressure aging:	T 240 and R 28												
Creep stiffness S, -18°C, MPa	T 313	-	300	-	-	-	300	-	300	-	300	-	300
m-value, -18°C		0.300	-	-	-	0.300	-	0.300	-	0.300	-	0.300	-

1. Non-Tracking Hot Applied Tack Coat - TRAIL product

- 2.3. Cutback Asphalt. Provide cutback asphalt that meets the requirements of Tables 4, 5, and 6, for the specified type and grade. Supply samples of the base asphalt cement and polymer additives if requested.

Table 4
Rapid-Curing Cutback Asphalt

Property	Test Procedure	Type-Grade					
		RC-250		RC-800		RC-3000	
		Min	Max	Min	Max	Min	Max
Kinematic viscosity, 140°F, cSt	T 201	250	400	800	1,600	3,000	6,000
Water, %	D95	–	0.2	–	0.2	–	0.2
Flash point, T.O.C., °F	T 79	80	–	80	–	80	–
Distillation test:	T 78						
Distillate, percentage by volume of total distillate to 680°F							
to 437°F		40	75	35	70	20	55
to 500°F		65	90	55	85	45	75
to 600°F		85	–	80	–	70	–
Residue from distillation, volume %		70	–	75	–	82	–
Tests on distillation residue:							
Viscosity, 140°F, poise	T 202	600	2,400	600	2,400	600	2,400
Ductility, 5 cm/min., 77°F, cm	T 51	100	–	100	–	100	–
Solubility in trichloroethylene, %	T 44	99.0	–	99.0	–	99.0	–
Spot test	Tex-509-C	Neg.		Neg.		Neg.	

Table 5
Medium-Curing Cutback Asphalt

Property	Test Procedure	Type-Grade							
		MC-30		MC-250		MC-800		MC-3000	
		Min	Max	Min	Max	Min	Max	Min	Max
Kinematic viscosity, 140°F, cSt	T 201	30	60	250	500	800	1,600	3,000	6,000
Water, %	D95	–	0.2	–	0.2	–	0.2	–	0.2
Flash point, T.O.C., °F	T 79	95	–	122	–	140	–	149	–
Distillation test:	T 78								
Distillate, percentage by volume of total distillate to 680°F									
to 437°F		–	35	–	20	–	–	–	–
to 500°F		30	75	5	55	–	40	–	15
to 600°F		75	95	60	90	45	85	15	75
Residue from distillation, volume %		50	–	67	–	75	–	80	–
Tests on distillation residue:									
Viscosity, 140°F, poise	T 202	300	1,200	300	1,200	300	1,200	300	1,200
Ductility, 5 cm/min., 77°F, cm	T 51	100	–	100	–	100	–	100	–
Solubility in trichloroethylene, %	T 44	99.0	–	99.0	–	99.0	–	99.0	–
Spot test	Tex-509-C	Neg.		Neg.		Neg.		Neg.	

Table 6
Special-Use Cutback Asphalt

Property	Test Procedure	Type-Grade					
		MC-2400L		SCM I		SCM II	
		Min	Max	Min	Max	Min	Max
Kinematic viscosity, 140°F, cSt	T 201	2,400	4,800	500	1,000	1,000	2,000
Water, %	D95	–	0.2	–	0.2	–	0.2
Flash point, T.O.C., °F	T 79	150	–	175	–	175	–
Distillation test:	T 78						
Distillate, percentage by volume of total distillate to 680°F							
to 437°F		–	–	–	–	–	–
to 500°F		–	35	–	0.5	–	0.5
to 600°F		35	80	20	60	15	50
Residue from distillation, volume %		78	–	76	–	82	–
Tests on distillation residue:							
Polymer		SBR		–		–	
Polymer content, % (solids basis)	Tex-533-C	2.0	–	–	–	–	–
Penetration, 100 g, 5 sec., 77°F	T 49	150	300	180	–	180	–
Ductility, 5 cm/min., 39.2°F, cm	T 51	50	–	–	–	–	–
Solubility in trichloroethylene, %	T 44	99.0	–	99.0	–	99.0	–

- 2.4. Emulsified Asphalt. Provide emulsified asphalt that is homogeneous, does not separate after thorough mixing, and meets the requirements for the specified type and grade in Tables 7, 8, 9, 10, and 10A-C.

Table 7
Emulsified Asphalt

Property	Test Procedure	Type-Grade									
		Rapid-Setting		Medium-Setting				Slow-Setting			
		HFRS-2		MS-2		AES-300		SS-1		SS-1H	
		Min	Max	Min	Max	Min	Max	Min	Max	Min	Max
Viscosity, Saybolt Furol 77°F, sec. 122°F, sec.	T 72	-	-	-	-	75	400	20	100	20	100
		150	400	100	300	-	-	-	-	-	-
Sieve test, %	T 59	-	0.1	-	0.1	-	0.1	-	0.1	-	0.1
Miscibility	T 59	-		-		-		Pass		Pass	
Cement mixing, %	T 59	-	-	-	-	-	-	-	2.0	-	2.0
Coating ability and water resistance: Dry aggregate/after spray Wet aggregate/after spray	T 59	-		-		Good/Fair Fair/Fair		-		-	
		-		-		-		-		-	
Demulsibility, 35 mL of 0.02 N CaCl ₂ , %	T 59	50	-	-	30	-	-	-	-	-	-
Storage stability, 1 day, %	T 59	-	1	-	1	-	1	-	1	-	1
Freezing test, 3 cycles ¹	T 59	-		Pass		-		Pass		Pass	
Distillation test: Residue by distillation, % by wt. Oil distillate, % by volume of emulsion	T 59	65	-	65	-	65	-	60	-	60	-
		-	0.5	-	0.5	-	5	-	0.5	-	0.5
Tests on residue from distillation: Penetration, 77°F, 100 g, 5 sec. Solubility in trichloroethylene, % Ductility, 77°F, 5 cm/min., cm Float test, 140°F, sec.	T 49	100	140	120	160	300	-	120	160	70	100
	T 44	97.5	-	97.5	-	97.5	-	97.5	-	97.5	-
	T 51	100	-	100	-	-	-	100	-	80	-
	T 50	1,200	-	-	-	1,200	-	-	-	-	-

1. Applies only when the Engineer designates material for winter use.

Table 8
Cationic Emulsified Asphalt

Property	Test Procedure	Type-Grade											
		Rapid-Setting		Medium-Setting				Slow-Setting					
		CRS-2		CRS-2H		CMS-2		CMS-2S		CSS-1		CSS-1H	
		Min	Max	Min	Max	Min	Max	Min	Max	Min	Max	Min	Max
Viscosity, Saybolt Furol 77°F, sec. 122°F, sec.	T 72	-	-	-	-	-	-	-	-	20	100	20	100
		150	400	150	400	100	300	100	300	-	-	-	-
Sieve test, %	T 59	-	0.1	-	0.1	-	0.1	-	0.1	-	0.1	-	0.1
Cement mixing, %	T 59	-	-	-	-	-	-	-	-	-	2.0	-	2.0
Coating ability and water resistance: Dry aggregate/after spray Wet aggregate/after spray	T 59	-		-		Good/Fair Fair/Fair		Good/Fair Fair/Fair		-		-	
		-		-		-		-		-		-	
Demulsibility, 35 mL of 0.8% Sodium dioctyl sulfosuccinate, %	T 59	70	-	70	-	-	-	-	-	-	-	-	-
Storage stability, 1 day, %	T 59	-	1	-	1	-	1	-	1	-	1	-	1
Particle charge	T 59	Positive		Positive		Positive		Positive		Positive		Positive	
Distillation test: Residue by distillation, % by wt. Oil distillate, % by volume of emulsion	T 59	65	-	65	-	65	-	65	-	60	-	60	-
		-	0.5	-	0.5	-	7	-	5	-	0.5	-	0.5
Tests on residue from distillation: Penetration, 77°F, 100 g, 5 sec. Solubility in trichloroethylene, % Ductility, 77°F, 5 cm/min., cm	T 49	120	160	70	110	120	200	300	-	120	160	70	110
	T 44	97.5	-	97.5	-	97.5	-	97.5	-	97.5	-	97.5	-
	T 51	100	-	80	-	100	-	-	-	100	-	80	-

Table 9
Polymer-Modified Emulsified Asphalt

Property	Test Procedure	Type-Grade									
		Rapid-Setting		Medium-Setting				Slow-Setting			
		HFRS-2P		AES-150P		AES-300P		AES-300S		SS-1P	
		Min	Max	Min	Max	Min	Max	Min	Max	Min	Max
Viscosity, Saybolt Furoil 77°F, sec. 122°F, sec.	T 72	-	-	75	400	75	400	75	400	30	100
Sieve test, %	T 59	-	0.1	-	0.1	-	0.1	-	0.1	-	0.1
Miscibility	T 59	-	-	-	-	-	-	-	-	-	Pass
Coating ability and water resistance: Dry aggregate/after spray Wet aggregate/after spray	T 59	-	-	Good/Fair Fair/Fair	Good/Fair Fair/Fair	Good/Fair Fair/Fair	Good/Fair Fair/Fair	Good/Fair Fair/Fair	Good/Fair Fair/Fair	-	-
Demulsibility, 35 mL of 0.02 N CaCl ₂ , %	T 59	50	-	-	-	-	-	-	-	-	-
Storage stability, 1 day, %	T 59	-	1	-	1	-	1	-	1	-	1
Breaking index, g	Tex-542-C	-	-	-	-	-	-	-	-	-	-
Distillation test: ¹ Residue by distillation, % by wt. Oil distillate, % by volume of emulsion	T 59	65	-	65	-	65	-	65	-	60	-
		-	0.5	-	3	-	5	-	7	-	0.5
Tests on residue from distillation: Polymer content, wt. % (solids basis)	Tex-533-C	3.0	-	-	-	-	-	-	-	3.0	-
Penetration, 77°F, 100 g, 5 sec.	T 49	90	140	150	300	300	-	300	-	100	140
Solubility in trichloroethylene, %	T 44	97.0	-	97.0	-	97.0	-	97.0	-	97.0	-
Viscosity, 140°F, poise	T 202	1,500	-	-	-	-	-	-	-	1,300	-
Float test, 140°F, sec	T 50	1,200	-	1,200	-	1,200	-	1,200	-	-	-
Ductility, ² 39.2°F, 5 cm/min., cm	T 51	50	-	-	-	-	-	-	-	50	-
Elastic recovery, 250°F, %	Tex-539-C	55	-	-	-	-	-	-	-	-	-
Tests on RTFO curing of distillation residue Elastic recovery, 50°F, %	T 240 Tex-536-C	-	-	50	-	50	-	30	-	-	-

1. Exception to T 59: Bring the temperature on the lower thermometer slowly to 350°F ±10°F. Maintain at this temperature for 20 min. Complete total distillation in 60 min. (±5 min.) from the first application of heat.

2. HFRS-2P must meet one of either the ductility or elastic recovery requirements.

Table 10
Polymer-Modified Cationic Emulsified Asphalt

Property	Test Procedure	Type-Grade											
		Rapid-Setting						Medium-Setting				Slow-Setting	
		CRS-2P		CHFRS-2P		CRS-2TR		CMS-1P ³		CMS-2P ³		CSS 1P	
		Min	Max	Min	Max	Min	Max	Min	Max	Min	Max	Min	Max
Viscosity, Saybolt Furol 77°F, sec. 122°F, sec.	T 72	-	-	-	-	-	-	10	100	-	-	20	100
		150	400	100	400	150	500	-	-	50	400	-	-
Sieve test, %	T 59	-	0.1	-	0.1	-	0.1	-	0.1	-	0.1	-	0.1
Demulsibility, 35 ml of 0.8% sodium dioctyl sulfosuccinate, %	T 59	70	-	60	-	40	-	-	-	-	-	-	-
Storage stability, 1 day, %	T 59	-	1	-	1	-	1	-	1	-	1	-	1
Breaking index, g	Tex-542-C	-	-	-	-	-	-	-	-	-	-	-	-
Particle charge	T 59	Positive		Positive		Positive		Positive		Positive		Positive	
Distillation test ¹ :	T 59												
Residue by distillation, % by weight		65	-	65	-	65	-	30	-	60	-	62	-
Oil distillate, % by volume of emulsion		-	0.5	-	0.5	-	3	-	0.5	-	0.5	-	0.5
Tests on residue from distillation:													
Polymer content, wt. % (solids basis)	Tex-533-C	3.0	-	3.0	-	5.0 ⁷	-	-	-	-	-	3.0	-
Penetration, 77°F, 100 g, 5 sec.	T 49	90	150	80	130	90	150	30	-	30	-	55	90
Viscosity, 140°F, poise	T 202	1,300	-	1,300	-	1,000	-	-	-	-	-	-	-
Solubility in trichloroethylene, %	T 44	97.0	-	95.0	-	98	-	-	-	-	-	97.0	-
Softening point, °F	T 53	-	-	-	-	-	-	-	-	-	-	135	-
Ductility, 77°F, 5 cm/min., cm	T 51	-	-	-	-	40	-	-	-	-	-	70	-
Float test, 140°F, sec.	T 50	-	-	1,800	-	-	-	-	-	-	-	-	-
Ductility, ² 39.2°F, 5 cm/min., cm	T 51	50	-	-	-	-	-	-	-	-	-	-	-
Elastic recovery, ² 50°F, %	Tex-539-C	55	-	55	-	-	-	-	-	-	-	-	-
Tests on residue from evaporative recovery:	R 78, Procedure B												
Nonrecoverable creep compliance of residue, 3.2 kPa, 52°C, kPa ⁻¹	T 350	-	-	-	-	-	-	-	2.0	-	4.0	-	-
Tests on rejuvenating agent:													
Viscosity, 140°F, cSt	T 201	-	-	-	-	-	-	50	175	50	175	-	-
Flash point, C.O.C., °F	T 48	-	-	-	-	-	-	380	-	380	-	-	-
Saturates, % by weight	D 2007	-	-	-	-	-	-	-	30	-	30	-	-
Solubility in n-pentane, % by weight	D 2007	-	-	-	-	-	-	99	-	99	-	-	-
Tests on rejuvenating agent after RTFO	T 240												
Weight Change, %		-	-	-	-	-	-	-	6.5	-	6.5	-	-
Viscosity Ratio		-	-	-	-	-	-	-	3.0	-	3.0	-	-
Tests on latex ⁴ :													
Tensile strength, die C dumbbell, psi	D 412 ⁵	-	-	-	-	-	-	800	-	800	-	-	-
Change in mass after immersion in rejuvenating agent, %	D 471	-	-	-	-	-	-	-	40 ⁶	-	40 ⁶	-	-

- Exception to T 59: Bring the temperature on the lower thermometer slowly to 350°F (±0°F). Maintain at this temperature for 20 min. Complete total distillation in 60 min. (±5 min.) from the first application of heat.
- CRS-2P must meet one of either the ductility or elastic recovery requirements.
- With all precertification samples of CMS-1P or CMS-2P, submit certified test reports showing that the rejuvenating agent and latex meet the stated requirements. Submit samples of these raw materials if requested by the Engineer.
- Preparation of latex specimens: use any substrate and recovery method which produces specimens of uniform dimensions and which delivers enough material to achieve desired residual thickness.
- Cut samples for tensile strength determination using a crosshead speed of 20 in. per minute.
- Specimen must remain intact after exposure and removal of excess rejuvenating agent.
- Modifier type is tire rubber.

Table 10A
Non-Tracking Tack Coat Emulsion¹

Property	Test Procedure	NT-HRE		NT-RRE		NT-SRE	
		Min	Max	Min	Max	Min	Max
Viscosity, Saybolt Furoil 77° F, sec.	T 72	15	–	15	–	10	100
Storage stability, 1 Day, %	T 59	–	1	–	1	–	1
Settlement, 5-day, %	T 59	–	5	–	5	–	5
Sieve test, %	T 59	–	0.30	–	0.30	–	0.1
Distillation test: ² Residue by distillation, % by wt. Oil distillate, by volume of emulsion	T 59	50	–	58	–	50	–
		–	1.0	–	1.0	–	1.0
Test on residue from distillation: Penetration, 77°F, 100 g, 5 sec.	T 49	–	20	15	45	40	90
Solubility in trichloroethylene, %	T 44	97.5	–	97.5	–	97.5	–
Softening point, °F	T 53	150	–	–	–	–	–
Dynamic shear, G*/sin(δ), 82°C, 10 rad/s, kPa	T 315	1.0	–	–	–	–	–

1. Due to the hardness of the residue, these emulsions should be heated to 120-140°F before thoroughly mixing as the emulsion is being prepared for testing.
2. Exception to T 59: Bring the temperature on the lower thermometer slowly to 350°F ± 10°F. Maintain at this temperature for 20 min. Complete total distillation in 60 ± 5 min. from first application of heat.

Table 10B
Spray Applied Underseal Membrane Polymer-Modified Emulsions (EBL)

Property	Test Procedure	Min	Max
Viscosity @ 77°F, SSF	T 72	20	100
Storage Stability ¹ , %	T 59	–	1
Demulsibility ² Anionic emulsions – 35 mL of 0.02 N CaCl ₂ , % Cationic emulsions – 35 mL of 0.8% sodium dioctyl sulfosuccinate, %	T 59	55	–
Sieve Test ³ , %	T 59	–	0.05
Distillation Test ⁴ Residue by distillation, % by wt. Oil portion of distillate, % by vol.	T 59	63	0.5
Test on Residue from Distillation Elastic Recovery @ 50°F, 50 mm/min., % Penetration @ 77°F, 100 g, 5 sec., 0.1 mm	Tex-539-C T 49	60 80	– 130

1. After standing undisturbed for 24 hr., the surface must be smooth, must not exhibit a white or milky colored substance, and must be a homogeneous color throughout.
2. Material must meet demulsibility test for emulsions.
3. May be required by the Engineer only when the emulsion cannot be easily applied in the field.
4. The temperature on the lower thermometer should be brought slowly to 350°F ± 10°F and maintained at this temperature for 20 min. The total distillation should be completed in 60 ± 5 min. from the first application of heat.

Table 10C
Full-Depth Reclamation Emulsion (FDR EM)

Property	Test Procedure	Standard Yield (SY)		High Yield (HY)	
		Min	Max	Min	Max
Sieve test, %	T 59	–	0.1	–	0.1
Viscosity Saybolt Furoil @ 77°F, sec.	T 59	20	100	20	100
Distillation test ¹ : Residue by distillation, % by wt. Oil portion of distillate, % by vol.	T 59	60	–	63	–
		–	0.5	–	0.5
Test on residue from distillation: Penetration @ 77°F, dmm	T 49	55	95	120	–
Test on rejuvenating agent: BWOA, % ² Viscosity @ 140°F, cSt Flash Point, COC, °F Solubility in n-pentane, % by wt.	*** T 201 T 48 D2007	– – – –	– – – –	2 50 380 99	– 175 – –

1. The temperature on the lower thermometer should be brought slowly to 350°F ± 10°F and maintained at this temperature for 20 min. The total distillation should be completed in 60 ± 5 min. from the first application of heat.
2. BWOA = By weight of asphalt. **Provide a manufacturer's** certificate of analysis (COA) with the percent of rejuvenator added.

- 2.5. Specialty Emulsions. Provide specialty emulsion that is either asphalt-based or resin-based and meets the requirements of Table 11 or Table 11A.

Table 11
Specialty Emulsions

Property	Test Procedure	Type-Grade					
		Medium-Setting				Slow-Setting	
		AE-P		EAP&T		PCE ¹	
		Min	Max	Min	Max	Min	Max
Viscosity, Saybolt Furol 77°F, sec. 122°F, sec.	T 72	- 15	- 150	- -	- -	10 -	100 -
Sieve test, %	T 59	-	0.1	-	0.1	-	0.1
Miscibility ²	T 59	-		Pass		Pass	
Demulsibility, 35 mL of 0.10 N CaCl ₂ , %	T 59	-	70	-	-	-	-
Storage stability, 1 day, %	T 59	-	1	-	1	-	-
Particle size, ⁵ % by volume < 2.5 μm	Tex-238-F³	-	-	90	-	90	-
Asphalt emulsion distillation to 500°F followed by Cutback asphalt distillation of residue to 680°F: Residue after both distillations, % by wt. Total oil distillate from both distillations, % by volume of emulsion	T 59 & T 78	40 25	- 40	- -	- -	- -	- -
Residue by distillation, % by wt.	T 59	-	-	60	-	-	-
Residue by evaporation, ⁴ % by wt.	T 59	-	-	-	-	60	-
Tests on residue after all distillations:							
Viscosity, 140°F, poise	T 202	-	-	800	-	-	-
Kinematic viscosity, ⁵ 140°F, cSt	T 201	-	-	-	-	100	350
Flash point C.O.C., °F	T 48	-	-	-	-	400	-
Solubility in trichloroethylene, %	T 44	97.5	-	-	-	-	-
Float test, 122°F, sec.	T 50	50	200	-	-	-	-

- Supply with each shipment of PCE:
 - a copy of a lab report from an approved analytical lab, signed by a lab official, indicating the PCE formulation does not meet any characteristics of a Resource Conservation Recovery Act (RCRA) hazardous waste;
 - a certification from the producer that the formulation supplied does not differ from the one tested and that no listed RCRA hazardous wastes or Polychlorinated Biphenyls (PCBs) have been mixed with the product; and
 - a Safety Data Sheet.
2. Exception to T 59: In dilution, use 350 mL of distilled or deionized water and a 1,000-mL beaker.
3. Use [Tex-238-F](#), beginning at "Particle Size Analysis by Laser Diffraction," with distilled or deionized water as a medium and no dispersant, or use another approved method.
4. Exception to T 59: Leave sample in the oven until foaming ceases, then cool and weigh.
5. PCE must meet either the kinematic viscosity requirement or the particle size requirement.

Table 11A
Hard Residue Surface Sealant

Property	Test Procedure	Min	Max
Viscosity, Krebs unit, 77°F, Krebs units	D 562	45	75
Softening point, °F	Tex-505-C ¹	250	–
Uniformity	D 2939	Pass ²	
Resistance to heat	D 2939	Pass ³	
Resistance to water	D 2939	Pass ⁴	
Wet flow, mm	D 2939	–	0
Resistance to Kerosene (optional) ⁵	D 2939	Pass ⁶	
Ultraviolet exposure, UVA-340, 0.77 W/m ² , 50°C chamber, 8 hr. UV lamp, 5 min. spray, 3 hr. 55 min. condensation, 1,000 hr. total exposure ⁷	G 154	Pass ⁸	
Abrasion loss, 1.6 mm thickness, liquid only, %	ISSA TB-100	–	1.0
Residue by evaporation, % by weight	D 2939	33	–
Tests on residue from evaporation: Penetration, 77°F, 100 g, 5 sec. Flash point, Cleveland open cup, °F	T 49 T 48	15 500	30
Tests on base asphalt before emulsification Solubility in trichloroethylene, %	T 44	98	–

1. Cure the emulsion in the softening point ring in a 200°F ± 5°F oven for 2 hr.
2. Product must be homogenous and show no separation or coagulation that cannot be overcome by moderate stirring.
3. No sagging or slippage of film beyond the initial reference line.
4. No blistering or re-emulsification.
5. Recommended for airport applications or where fuel resistance is desired.
6. No absorption of Kerosene into the clay tile past the sealer film. Note sealer surface condition and loss of adhesion.
7. Other exposure cycles with similar levels of irradiation and conditions may be used with Department approval.
8. No cracking, chipping, surface distortion, or loss of adhesion. No color fading or lightening.

- 2.6. Recycling Agent. Recycling agent and emulsified recycling agent must meet the requirements in Table 12. Additionally, recycling agent and residue from emulsified recycling agent, when added in the specified proportions to the recycled asphalt, must meet the properties specified on the plans.

Table 12
Recycling Agent and Emulsified Recycling Agent

Property	Test Procedure	Recycling Agent		Emulsified Recycling Agent (ARA-1)		Polymer Modified Emulsified Recycling Agent (ARA-1P)	
		Min	Max	Min	Max	Min	Max
Viscosity, Saybolt Furol, 77°F, sec.	T 72	–	–	15	100	15	110
Sieve test, %	T 59	–	–	–	0.1	–	0.1
Miscibility ¹	T 59	–		No coagulation			
Residue by evaporation, ² % by wt.	T 59	–	–	60	–	–	–
Distillation test: Residue by distillation, % by wt. Oil distillate, % by volume of emulsion	T 59					60 –	65 2
Penetration of Distillation Residue at 39.2°F, 100 g, 5 sec.	T 49					110	190
Tests on recycling agent or residue from evaporation: Flash point, C.O.C., °F Kinematic viscosity, 140°F, cSt 275°F, cSt	T 48 T 201	400 75 –	– 200 10.0	400 75 –	– 200 10.0	400	–

- Exception to T 59: Use 0.02 N CaCl₂ solution in place of water.
- Exception to T 59: Maintain sample at 300°F until foaming ceases, then cool and weigh.

2.7. Crumb Rubber Modifier. Crumb rubber modifier (CRM) consists of automobile and truck tires processed by ambient temperature grinding.

CRM must be:

- free from contaminants including fabric, metal, and mineral and other nonrubber substances;
- free-flowing; and
- nonfoaming when added to hot asphalt binder.

Ensure rubber gradation meets the requirements of the grades in Table 13 when tested in accordance with [Tex-200-F](#), Part I, using a 50-g sample.

Table 13
CRM Gradations

Sieve Size (% Passing)	Grade A		Grade B		Grade C		Grade D	Grade E
	Min	Max	Min	Max	Min	Max		
#8	100	–	–	–	–	–	As shown on the plans	As approved
#10	95	100	100	–	–	–		
#16	–	–	70	100	100	–		
#30	–	–	25	60	90	100		
#40	–	–	–	–	45	100		
#50	0	10	–	–	–	–		
#200	–	–	0	5	–	–		

2.8. Crack Sealer. Provide polymer-modified asphalt-emulsion crack sealer meeting the requirements of Table 14. Provide rubber-asphalt crack sealer meeting the requirements of Table 15.

Table 14
Polymer-Modified Asphalt-Emulsion Crack Sealer

Property	Test Procedure	Min	Max
Rotational viscosity, 77°F, cP	D 2196, Method A	10,000	25,000
Sieve test, %	T 59	–	0.1
Storage stability, 1 day, %	T 59	–	1
Evaporation	Tex-543-C		
Residue by evaporation, % by wt.		65	–
Tests on residue from evaporation:			
Penetration, 77°F, 100 g, 5 sec.	T 49	35	75
Softening point, °F	T 53	140	–
Ductility, 39.2°F, 5 cm/min., cm	T 51	100	–

Table 15
Rubber-Asphalt Crack Sealer

Property	Test Procedure	Class A		Class B	
		Min	Max	Min	Max
CRM content, Grade A or B, % by wt.	Tex-544-C	22	26	–	–
CRM content, Grade B, % by wt.	Tex-544-C	–	–	13	17
Virgin rubber content, ¹ % by wt.		–	–	2	–
Flash point, ² C.O.C., °F	T 48	400	–	400	–
Penetration, ³ 77°F, 150 g, 5 sec.	T 49	30	50	30	50
Penetration, ³ 32°F, 200 g, 60 sec.	T 49	12	–	12	–
Softening point, °F	T 53	–	–	170	–
Bond Test, non-immersed, 0.5 in specimen, 50% extension, 20°F ⁴	D5329	–	–	–	Pass

1. Provide certification that the Min % virgin rubber was added.
2. Agitate the sealing compound with a 3/8- to 1/2 in. (9.5- to 12.7 mm) wide, square-end metal spatula to bring the material on the bottom of the cup to the surface (i.e., turn the material over) before passing the test flame over the cup. Start at one side of the thermometer, move around to the other, and then return to the starting point using 8 to 10 rapid circular strokes. Accomplish agitation in 3 to 4 sec. Pass the test flame over the cup immediately after stirring is completed.
3. Exception to T 49: Substitute the cone specified in D 217 for the penetration needle.
4. Allow no crack in the crack sealing materials or break in the bond between the sealer and the mortar blocks over 1/4 in. deep for any specimen after completion of the test.

- 2.9. Asphalt-Rubber Binders. Provide asphalt-rubber (A-R) binders that are mixtures of asphalt binder and CRM, which have been reacted at elevated temperatures. Provide A-R binders meeting D6114 and containing a minimum of 15% CRM by weight. Provide Types I or II, containing CRM Grade C, for use in hot-mixed aggregate mixtures. Provide Types II or III, containing CRM Grade B, for use in surface treatment binder. Ensure binder properties meet the requirements of Table 16.

Table 16
A-R Binders

Property	Test Procedure	Binder Type					
		Type I		Type II		Type III	
		Min	Max	Min	Max	Min	Max
Apparent viscosity, 347°F, cP	D2196, Method A	1,500	5,000	1,500	5,000	1,500	5,000
Penetration, 77°F, 100 g, 5 sec.	T 49	25	75	25	75	50	100
Penetration, 39.2°F, 200 g, 60 sec.	T 49	10	–	15	–	25	–
Softening point, °F	T 53	135	–	130	–	125	–
Resilience, 77°F, %	D5329	25	–	20	–	10	–
Flash point, C.O.C., °F	T 48	450	–	450	–	450	–
Tests on residue from Thin-Film Oven Test:	T 179						
Retained penetration ratio, 39.2°F, 200 g, 60 sec., % of original	T 49	75	–	75	–	75	–

2.10. Performance-Graded Binders. Provide PG binders that are smooth and homogeneous, show no separation when tested in accordance with [Tex-540-C](#), and meet the requirements of Table 17.

Separation testing is not required if:

- a modifier is introduced separately at the mix plant either by injection in the asphalt line or mixer,
- the binder is blended on site in continuously agitated tanks, or
- binder acceptance is based on field samples taken from an in-line sampling port at the hot-mix plant after the addition of modifiers.

Table 17
Performance-Graded Binders

Property and Test Method	Performance Grade																	
	PG 58			PG 64				PG 70				PG 76				PG 82		
	-22	-28	-34	-16	-22	-28	-34	-16	-22	-28	-34	-16	-22	-28	-34	-16	-22	-28
Average 7-day max pavement design temperature, °C ¹	58			64				70				76				82		
Min pavement design temperature, °C ¹	-22	-28	-34	-16	-22	-28	-34	-16	-22	-28	-34	-16	-22	-28	-34	-16	-22	-28
Original Binder																		
Flash point, T 48, Min, °C	230																	
Viscosity, T 316 ^{2,3} : Max, 3.0 Pa s, test temperature, °C	135																	
Dynamic shear, T 315 ⁴ : G*/sin(δ), Min, 1.00 kPa, Max, 2.00 kPa ⁷ , Test temperature @ 10 rad/sec., °C	58			64				70				76				82		
Elastic recovery, D6084, 50°F, % Min ⁸	-	-	30	-	-	30	50	-	30	50	60	30	50	60	70	50	60	70
Rolling Thin-Film Oven (Tex-506-C)																		
Mass change, T 240, Max, %	1.0																	
Dynamic shear, T 315: G*/sin(δ), Min, 2.20 kPa, Max, 5.00 kPa ⁷ , Test temperature @ 10 rad/sec., °C	58			64				70				76				82		
MSCR, T350, Recovery, 0.1 kPa, High Temperature, % Min ⁸	-	-	20	-	-	20	30	-	20	30	40	20	30	40	50	30	40	50
Pressure Aging Vessel (PAV) Residue (R 28)																		
PAV aging temperature, °C	100																	
Dynamic shear, T 315: G*/sin(δ), Max, 5,000 kPa Test temperature @ 10 rad/sec., °C	25	22	19	28	25	22	19	28	25	22	19	28	25	22	19	28	25	22
Creep stiffness, T 313 ^{5,6} : S, max, 300 MPa, m-value, Min, 0.300 Test temperature @ 60 sec., °C	-12	-18	-24	-6	-12	-18	-24	-6	-12	-18	-24	-6	-12	-18	-24	-6	-12	-18
Direct tension, T 314 ⁶ : Failure strain, min, 1.0% Test temperature @ 1.0 mm/min., °C	-12	-18	-24	-6	-12	-18	-24	-6	-12	-18	-24	-6	-12	-18	-24	-6	-12	-18

- Pavement temperatures are estimated from air temperatures and using an algorithm contained in a Department-supplied computer program, may be provided by the Department, or by following the procedures outlined in AASHTO MP 2 and PP 28.
- This requirement may be waived at the Department's discretion if the supplier warrants that the asphalt binder can be adequately pumped, mixed, and compacted at temperatures that meet all applicable safety, environmental, and constructability requirements.** At test temperatures where the binder is a Newtonian fluid, any suitable standard means of viscosity measurement may be used, including capillary (T 201 or T 202) or rotational viscometry (T 316).
- Viscosity at 135°C is an indicator of mixing and compaction temperatures that can be expected in the lab and field. High values may indicate high mixing and compaction temperatures. Additionally, significant variation can occur from batch to batch. Contractors should be aware that variation could significantly impact their mixing and compaction operations. Contractors are therefore responsible for addressing any constructability issues that may arise.
- For quality control of unmodified asphalt binder production, measurement of the viscosity of the original asphalt binder may be substituted for dynamic shear measurements of G*/sin(δ) at test temperatures where the asphalt is a Newtonian fluid. Any suitable standard means of viscosity measurement may be used, including capillary (T 201 or T 202) or rotational viscometry (T 316).
- Silicone beam molds, as described in AASHTO TP 1-93, are acceptable for use.
- If creep stiffness is below 300 MPa, direct tension test is not required. If creep stiffness is between 300 and 600 MPa, the direct tension failure strain requirement can be used instead of the creep stiffness requirement. The m value requirement must be satisfied in both cases.
- Maximum values for unaged and RTFO aged dynamic shear apply only to materials used as substitute binders, as described in Item 340, "Dense-Graded Hot-Mix Asphalt (Small Quantity)", Item 341, "Dense-Graded Hot-Mix Asphalt, and Item 344, "Superpave Mixtures."
- Elastic Recovery (ASTM D6084) is not required unless MSCR (AASHTO T 350) is less than the minimum % recovery. Elastic Recovery must be used for the acceptance criteria in this instance.

3. EQUIPMENT

Provide all equipment necessary to transport, store, sample, heat, apply, and incorporate asphalts, oils, and emulsions.

4. CONSTRUCTION

Typical Material Use. Use materials shown in Table 18, unless otherwise determined by the Engineer.

Table 18
Typical Material Use

Material Application	Typically Used Materials
Hot-mixed, hot-laid asphalt mixtures	PG binders, A-R binders Types I and II
Surface treatment	AC-5, AC-10, AC-15P, AC-20XP, AC-10-2TR, AC-20-5TR, HFRS-2, MS-2, CRS-2, CRS-2H, CRS-2TR, CMS-2P HFRS-2P, CRS-2P, CHFRS-2P, A-R binders Types II and III
Surface treatment (cool weather)	AC12-5TR, RC-250, RC-800, RC-3000, MC-250, MC-800, MC-3000, MC-2400L, CMS-2P
Precoating	AC-5, AC-10, PG 64-22, SS-1, SS-1H, CSS-1, CSS-1H
Tack coat	PG Binders, SS-1H, CSS-1H, EAP&T, TRAIL, EBL
Fog seal	SS-1, SS-1H, CSS-1, CSS-1H, CMS-1P
Hot-mixed, cold-laid asphalt mixtures	AC-0.6, AC-1.5, AC-3, AES-300, AES-300P, CMS-2, CMS-2S
Patching mix	MC-800, SCM I, SCM II, AES-300S
Recycling	AC-0.6, AC-1.5, AC-3, AES-150P, AES-300P, recycling agent, emulsified recycling agent
Crack sealing	SS-1P, polymer mod AE crack sealant, rubber asphalt crack sealers (Class A, Class B)
Microsurfacing	CSS-1P
Prime	MC-30, AE-P, EAP&T, PCE
Curing membrane	SS-1, SS-1H, CSS-1, CSS-1H, PCE
Erosion control	SS-1, SS-1H, CSS-1, CSS-1H, PCE
FDR -Foaming	PG 64-22, FDR EM-SY, FDR EM-HY

- 4.1. Storage and Application Temperatures. Use storage and application temperatures in accordance with Table 19. Store and apply materials at the lowest temperature yielding satisfactory results. Follow the **manufacturer's instructions for any agitation requirements in storage. Manufacturer's instructions regarding recommended application and storage temperatures supersede those of Table 19.**

Table19
Storage and Application Temperatures

Type-Grade	Application		Storage Max (°F)
	Recommended Range (°F)	Max Allowable (°F)	
AC-0.6, AC-1.5, AC-3	200–300	350	350
AC-5, AC-10	275–350	350	350
AC-15P, AC-20-5TR, AC12-5TR and AC10-2TR	300–375	375	360
RC-250	125–180	200	200
RC-800	170–230	260	260
RC-3000	215–275	285	285
MC-30, AE-P	70–150	175	175
MC-250	125–210	240	240
MC-800, SCMI, SCM II	175–260	275	275
MC-3000, MC-2400L	225–275	290	290
HFRS-2, MS-2, CRS-2, CRS-2H, HFRS-2P, CRS-2P, CMS-2, CMS-2S, AES-300, AES-300S, AES-150P, AES-300P, CRS-2TR	120–160	180	180
SS-1, SS-1H, CSS-1, CSS-1H, PCE, EAP&T, SS-1P, RS-1P, CRS-1P, CSS-1P, recycling agent, emulsified recycling agent, polymer mod AE crack sealant	50–130	140	140
PG binders	275–350	350	350
Rubber asphalt crack sealers (Class A, Class B)	350–375	400	–
A-R binders Types I, II, and III	325–425	425	425

5. MEASUREMENT AND PAYMENT

The work performed, materials furnished, equipment, labor, tools, and incidentals will not be measured or paid for directly but is subsidiary or is included in payment for other pertinent items.

Special Specification 6001

Portable Changeable Message Sign



1. DESCRIPTION

Furnish, operate, and maintain portable trailer mounted changeable message sign (PCMS) units.

2. MATERIALS

Furnish new or used material in accordance with the requirements of this Item and the details shown on the plans. Provide a self-contained PCMS unit with the following:

- Sign controller
- Changeable Message Sign
- Trailer
- Power source

Paint the exterior surfaces of the power supply housing, supports, trailer, and sign with Federal Orange No. 22246 or Federal Yellow No. 13538 of Federal Standard 595C, except paint the sign face assembly flat black.

- 2.1. **Sign Controller.** Provide a controller with permanent storage of a minimum of 75 pre-programmed messages. Provide an external input device for random programming and storage of a minimum of 75 additional messages. Provide a controller capable of displaying up to 3 messages sequentially. Provide a controller with adjustable display rates. Enclose sign controller equipment in a lockable enclosure.
- 2.2. **Changeable Message Sign.** Provide a sign capable of being elevated to at least 7 ft. above the roadway surface from the bottom of the sign. Provide a sign capable of being rotated 360° and secured against movement in any position.
- Provide a sign with 3 separate lines of text and 8 characters per line minimum. Provide a minimum 18 in. character height. Provide a 5 × 7 character pixel matrix. Provide a message legibility distance of 600 ft. for nighttime conditions and 800 ft. for normal daylight conditions. Provide for manual and automatic dimming light sources.
- The following are descriptions for 3 screen types of PCMS:
- **Character Modular Matrix.** This screen type comprises of character blocks.
 - **Continuous Line Matrix.** This screen type uses proportionally spaced fonts for each line of text.
 - **Full Matrix.** This screen type uses proportionally spaced fonts, varies the height of characters, and displays simple graphics on the entire sign.
- 2.3. **Trailer.** Provide a 2 wheel trailer with square top fenders, 4 leveling jacks, and trailer lights. Do not exceed an overall trailer width of 96 in. Shock mount the electronics and sign assembly.
- 2.4. **Power Source.** Provide a diesel generator, solar powered power source, or both. Provide a backup power source as necessary.
- 2.5. **Cellular Telephone.** When shown on the plans, provide a cellular telephone connection to communicate with the PCMS unit remotely.

3. CONSTRUCTION

Place or relocate PCMS units as shown on the plans or as directed. The plans will show the number of PCMS units needed, for how many days, and for which construction phases.

Maintain the PCMS units in good working condition. Repair damaged or malfunctioning PCMS units as soon as possible. PCMS units will remain the property of the Contractor.

4. MEASUREMENT

This Item will be measured by each PCMS or by the day used. All PCMS units must be set up on a work area and operational before a calendar day can be considered measurable. When measurement by the day is specified, a day will be measured for each PCMS set up and operational on the worksite.

5. PAYMENT

The work performed and materials furnished in accordance with this Item and measured as provided under "Measurement" will be paid for at the unit price bid for "Portable Changeable Message Sign." This price is full compensation for PCMS units; set up; relocating; removing; replacement parts; batteries (when required); fuel, oil, and oil filters (when required); cellular telephone charges (when required); software; and equipment, materials, tools, labor, and incidentals.

Special Specification 6019

Longitudinal Prefabricated Pavement Markings (PPM) with Warranty



1. DESCRIPTION

Furnish and place longitudinal PPM as shown on the plans. Provide a manufacturer's warranty bond for a 6 year period. The Department will allow a Contractor provided warranty bond instead of the manufacturer's bond if all conditions of the manufacturer's warranty, including the requirements of this Item, are met. In such case, the Contractor is responsible for meeting the warranty requirements. Use the form provided by the Department. The Department will allow substitution of a contractor's bond with a manufacturer's bond after execution of the Contract before final acceptance.

2. MATERIALS

Use pavement markings that meet the requirements of Type B in DMS-8240, "Permanent Prefabricated Pavement Markings," and that are shown on the Department's MPL.

3. EQUIPMENT

Provide equipment as required or directed according to the following: (The provider of the warranty bond is responsible for providing equipment during the warranty period unless otherwise shown on the plans.)

- 3.1. **Preparation and Application.** Use equipment designed for the pavement preparation and application of the type of PPM material selected.
- 3.2. **Colorimeter.** Provide a colorimeter using 45°/0° geometry CIE, D65 Illuminant, 2° standard observation angle meeting the requirements of ASTM E1347, E1348, or E1349.
- 3.3. **Retroreflectometer.** Unless otherwise shown on the plans, provide a portable or mobile retroreflectometer meeting the following requirements.
- 3.3.1. **Portable Retroreflectometer.** Provide a portable retroreflectometer that meets the requirements of ASTM E1710.
- 3.3.2. **Mobile Retroreflectometer.** Provide a mobile retroreflectometer that:
- is approved by the Construction Division (CST) and certified by the Texas Transportation Institute Mobile Retroreflectometer Certification Program for project evaluation of retroreflectivity
 - is calibrated daily, before measuring retroreflectivity on any pavement stripe, with a portable retroreflectometer meeting the following requirements: ASTM E1710, entrance angle of 88.76°, observation angle of 1.05°, and an accuracy of ±15%; and
 - requires no traffic control when retroreflectivity measurements are taken and is capable of taking continuous readings at or near posted speeds

Furnish mobile retroreflectivity measurements in compliance with Special Specification, "Mobile Retroreflectivity Data Collection for Pavement Markings," unless otherwise approved by the Engineer. The Engineer may require an occasional field comparison check with a portable retroreflectometer meeting the requirements listed above to ensure accuracy.

4. CONSTRUCTION

- 4.1. **General.** Prepare the pavement surface using controlled techniques that minimize pavement damage and hazards to the traveling public. Apply the PPM materials according to the manufacturer's recommendations, using widths, colors, and shapes at locations as shown on the plans.

Obtain approval for the sequence of work and estimated daily production. Use traffic control as shown on the plans or as approved. Establish guides to mark the lateral location of pavement markings as shown on the plans or as directed, and have guide locations verified. Use material for guides that will not leave a permanent mark on the roadway. Apply markings in alignment with the guides and without deviating for the alignment more than 1 in. per 200 ft. of roadway or more than 2 in. maximum. Remove all applied markings that are not in alignment or sequence as stated in the plans or as stated in the specifications at the Contractor's expense and in accordance with Item 677, "Eliminating Existing Pavement Markings and Markers," except for measurement and payment.

- 4.2. **Initial Performance Requirements.** Meet Article 5, "Performance Requirements" initially, after installation.

The Engineer will conduct visual performance evaluations of PPM. For markings that do not meet the Engineer's visual performance evaluation, the Contractor may present test results for color (using a colorimeter), retroreflectivity (using a retroreflectometer in accordance with this Item), and durability (in accordance with ASTM D913) for the Engineer's use in making acceptance or rejection decisions.

For PPM not meeting performance requirements, repair or replace until reevaluation shows the PPM meet the performance requirements as approved by the Engineer.

- 4.3. **Written Acceptance.** The Department will provide written acceptance after the Contractor meets the initial performance requirements. This written acceptance (see attached sample form) will include the date, location, length, and type of PPM.

5. PERFORMANCE REQUIREMENTS

- 5.1. **Color.** Provide PPM consisting of pigments blended to provide color conforming to highway colors as shown in Table 1.

Table 1
Color Requirements

Federal 595 Color		Chromaticity Coordinates								Brightness (Y)
		1		2		3		4		
		x	y	x	y	X	y	x	y	
White	17855	.290	.315	.310	.295	.350	.340	.330	.360	60 Min
Yellow	33538	.470	.455	.510	.489	.490	.432	.537	.462	30 Min
Black										5 Max

- 5.2. **Retroreflectivity.** Provide PPM for longitudinal markings meeting the minimum retroreflectivity values listed in Table 2.

Table 2
Minimum Retroreflectivity Requirements

Color	Retroreflectivity, mcd/m ² /lx, Min
White	120
Yellow	120

- 5.3. **Durability.** Provide PPM that do not lose more than 5% of the striping material in a 1,000-ft. section of continuous stripe or broken stripe (25 broken stripes). Pavement markings must remain in the proper alignment and location.

- 5.4. **Performance Evaluation Procedures.** Provide traffic control and conduct evaluations of color, retroreflectivity, and durability as required or directed.
- 5.4.1. **Color.** Measure color using 45°/0° geometry CIE, D65 Illuminant, 2° standard observation angle in accordance with ASTM E 1347, E 1348, or E 1349.
- 5.4.2. **Retroreflectivity.** Unless otherwise shown on the plans, conduct retroreflectivity evaluations of pavement markings with either a portable or mobile retroreflectometer. Make all measurements in the direction of traffic flow, except for broken centerline on 2-way roadways, where measurements will be made in both directions.
- If using a portable retroreflectometer, take a minimum of 1 measurement every mile on each series of markings (i.e., edgeline, center skipline, each line of a double line, etc.), at locations approved by the Engineer. If more than 1 measurement is taken, average the measurements. For all markings measured in both directions, take a minimum of 1 measurement in each direction. If the measurement taken on a specific series of markings within each mile segment falls below the minimum retroreflectivity values, take a minimum of 5 more measurements at locations determined by the Engineer within that mile segment for that series of marking. If the average of these 5 measurements falls below the minimum retroreflectivity requirements, that mile segment of the applied markings does not meet the performance requirement.
- If using a mobile retroreflectometer, review the results to determine deficient sections and deficient areas of interest. These areas do not meet the performance requirements.
- 5.4.3. **Durability.** Measure durability in accordance with ASTM D913 for marking material loss and visual inspection for alignment and location. Conduct evaluations at locations approved by the Engineer.

6. WARRANTY REQUIREMENTS

Each warranty period is for 6 yr. and starts the day after written acceptance.

The marking warrantor is responsible for meeting Article 5, "Performance Requirements," for the duration of the warranty period.

During the warranty period, the Engineer will conduct periodic visual performance evaluations of PPM. For retroreflectivity the Engineer will use Tex-828-B, "Determining Functional Characteristics of Pavement Markings." The warrantor may be present during these evaluations. For areas, which, in the opinion of the Engineer, have a questionable visual evaluation, the warrantor may replace the PPM or may conduct a performance evaluation for the performance requirement in question, according to Section 5.4., "Performance Evaluation Procedures." Conduct retroreflectivity evaluations according to Section 5.4.2., "Retroreflectivity," using either portable or mobile retroreflectometer unless otherwise shown on the plans. The warrantor is responsible for traffic control when conducting performance evaluations.

The warrantor will replace PPM that fails to meet the color, retroreflectivity, or durability performance requirements during the warranty period. Replace PPM that fails to meet the performance requirements within 30 days of notification.

All replacement PPM must meet the materials and performance requirements of this specification, under the following conditions to complete the warranty period:

If the longitudinal PPM fails to meet the performance requirements in Article 5 in Years 1 through 4, use materials meeting Type B requirements of specification DMS-8240.

If the longitudinal PPM fails to meet the performance requirements in Article 5 in Years 5 or 6, use materials that meet DMS-8240 (Type A or B), or on the Department's MPL, to meet the performance requirements of Article 5.

The end of the warranty period does not relieve the warrantor from the performance deficiencies requiring corrective action identified during the warranty period.

The Engineer may exclude PPM from the replacement provisions of the warranty period, provided the Engineer determines that the failure is a result of outside causes rather than defective material. Examples of outside causes are extreme wear at intersections, damage by snow or ice removal, and premature pavement failure.

Provide a contact person, address and telephone number for notification of needed PPM replacement.

7. MEASUREMENT

This Item will be measured by the foot or by any other unit shown on the plans. Each stripe will be measured separately.

This is a plans quantity measurement Item. The quantity to be paid is the quantity shown in the proposal unless modified by Article 9.2., "Plans Quantity Measurement." Additional measurements or calculations will be made if adjustments of quantities are required.

8. PAYMENT

The work performed and materials furnished in accordance with this Item and measured as provided under "Measurement" will be paid for at the unit price bid for "Longitudinal Prefabricated Pavement Markings (PPM) with Warranty" of the color, shape and width, specified as applicable, at the time of project acceptance. This price is full compensation for materials, application of longitudinal PPM, testing, warranty work, equipment, labor, tools, and incidentals.

WMS INSTALLATION RECORD FOR WRITTEN ACCEPTANCE

** Warranty period begins the day after written acceptance.

COUNTY HIGHWAY	CONTROL PROJECT	LIMITS FROM LIMITS TO	LENGTH	TYPE PPM	ACCEPTANCE DATE

Contractor Signature _____
Date

Department Signature _____
Date

WARRANTY BOND	CONTRACT NO.	
	COUNTY	
	BOND NO	

KNOW ALL PERSONS BY THESE PRESENTS: That we, _____, manufacturer of or Contractor for prefabricated pavement markings, as Principal, and _____, as Surety, are held and firmly bound unto the State of Texas, as Oblige, in the penal sum of _____ Dollars \$ _____, lawful money of the United States, well and truly to be paid to the State of Texas, and we bind ourselves, our heirs, successors, executors, and administrators jointly and severally, firmly by these presents.

Whereas, the above bounden Principal has provided prefabricated pavement markings to _____ for the foregoing contract entered into between _____ and the Oblige, attached hereto; and

Whereas, the Principal is required to protect the Oblige against any defects resulting from faulty prefabricated pavement markings installed under said contract for a period of 6 years beginning the day after written acceptance.

Now, therefore, the condition of this obligation is such that if the above bounden principal, its heirs, successors, executors, and administrators shall promptly and faithfully carry out and perform the warranty as provided in said contract, and shall, within thirty days of due notice, replace any installed prefabricated pavement markings that may fail to meet Oblige's performance evaluation as provided for in the Contract during the period specified above or shall pay over, make good, and reimburse to the said Oblige all loss and damage that said Oblige may sustain by reason of failure or default of said Principal so to do, then this obligation shall be null and void, otherwise it shall remain in full force and effect.

Provided further that the end of a warranty period shall not relieve Principal from its obligation to correct deficiencies requiring corrective action, so long as those deficiencies are identified during the warranty period.

WITNESS our hand this _____ day of _____ 20 _____

(Warrantor Name)

* By: _____
****SURETY** (Print Firm Name and Seal) (Warrantor Officer)

* By: _____ * By: _____
 (Title) (Warrantor Officer)

****SURETY** (Print Firm Name and Seal) ****SURETY** (Print Firm Name and Seal)

* By: _____ * By: _____
 (Title) (Title)

Note:

- * Attach a Power of Attorney showing that the officer of the installing contractor has authority to sign this obligation.
- ** Attach a Power of Attorney showing that the surety officer or Attorney-In-Fact has authority to sign this obligation; the Power of Attorney and bond must be impressed with the corporate seal. The surety must be a US Treasury listed company and provide notification information.

Special Specification 6058

Battery Back-Up System for Signal Cabinets



1. DESCRIPTION

Install a Battery Back-Up System (BBU System) for traffic signals that will provide reliable emergency power in the event of utility power failure or interruption. The system will also function as a power conditioner and/or voltage regulation device.

A BBU System consists of inverter/charger, manual bypass switch, power transfer switch or automatic bypass switch, batteries, battery monitoring device, wiring, external cabinet or stand-alone cabinet, concrete pad, all necessary hardware and software, and all associated equipment required to operate in a field environment.

The BBU System shall be capable of operating an "LED only" signalized intersection (700W load) for 4 hours of full runtime when utility power is disabled and under ambient temperatures of 25oC. The BBU System shall switch the intersection to flash mode of operation when approximately 40% of battery charge is remaining, via relay contact connection points on the front panel of the unit. The BBU system shall operate the intersection in the flash mode of operation (300W load) for an additional 2 hours. BBU system components shall be rated for a minimum 1400W load capacity.

The BBU shall be designed for outdoor applications in accordance with NEMA TS2-2003, Section 2. All components of the BBU system shall be rated to operate under temperature extremes of -34oC to +74oC.

2. DEFINITIONS

- 2.1. **Automatic Bypass Switch.** A unit connected between the utility power supply and the inverter/charger which can automatically switch power to the controller cabinet service panel from inverter output power to utility line power.
- 2.2. **Battery Back-Up System (BBU System).** The battery back-up system includes, but is not limited to, a manual bypass switch, automatic bypass switch or power transfer switch, inverter/charger, batteries, battery monitoring device, wiring, external cabinet and all necessary hardware for system operation.
- 2.3. **Battery Back-Up System Software.** All software associated with operation, programming and functional requirements of the BBU system.
- 2.4. **Battery Monitoring Device.** The device which monitors battery temperatures and charge rate of the batteries used in the BBU system.
- 2.5. **Batteries.** Standard 12V batteries wired in series to create a 36VDC to 96VDC voltage storage.
- 2.6. **Boost.** When enabled, the BBU inverter/charger shall automatically switch into this mode to raise the utility line voltage when it drops below a preset limit. The limit may be user defined or use manufacturer default settings (typically 100V AC).
- 2.7. **Buck.** When enabled, the unit shall automatically switch into this mode to reduce the utility line voltage when it rises above a preset limit. The limit may be user defined or use manufacturer default settings (typically 135V AC).
- 2.8. **External or Stand-Alone Cabinet.** The structure which houses the system components and/or batteries for the BBU System.

- 2.9. **Inverter/Charger.** The unit which converts the DC voltage input into 120 VAC output for the traffic signal cabinet to operate. As a minimum the inverter/charger shall be rated for 1400 watts.
- 2.10. **Inverter Line Voltage.** The power supplied from the BBU system to the traffic signal cabinet from the BBU System inverter.
- 2.11. **Manual Bypass.** Manual switch that allows user to bypass BBU power to service system equipment. Manual bypass switch switches utility line power directly to cabinet.
- 2.12. **Power Transfer Switch.** A unit connected between the utility power supply and the inverter/charger which can automatically switch from utility line power to inverter output power. The power transfer relay may be a separate unit or combined with the manual bypass switch. In the event of battery voltage loss, the power transfer switch will automatically return to utility line power.
- 2.13. **Signal Operation Mode.** A signalized intersection generating a 700W load when running in normal operation.
- 2.14. **Signal Flash Mode.** A signalized intersection generating a 300W load when running in the flash mode of operation.
- 2.15. **Utility Line Voltage.** The 120V AC power supplied to the BBU system.

3. EQUIPMENT

Ensure electrical materials and construction methods conform to the current NEC and additional local utility requirements. Furnish battery back-up systems prequalified by the Department. The Traffic Operations Division maintains a Material Producer List (MPL) of prequalified battery back-up systems. Ensure all materials and construction methods conform to the details shown on the plans, the requirements of this Item, and the pertinent requirements of the following Items:

- Item 420, "Concrete Substructures"
- Item 620, "Electrical Conductors"

Provide and install a BBU system that is able to fulfill the following requirements:

- 3.1. **Method of Operation.** The BBU system shall operate using one or more of the following methods:
- 3.1.1. **Buck and Boost Method.** When the buck and boost functions are enabled they shall set the upper and lower control limit allowable for the utility line voltage.
- If the utility line voltage fluctuates above or below the buck and boost values, the BBU system shall raise or lower the voltage by approximately 10-15% of the utility line voltage in an attempt to bring the voltage back into the upper and lower control limits. Buck and boost shall have preset manufacturer defaults.
- If the utility line voltage falls above or below the functional capabilities of buck and boost, then the BBU system will transfer power from the utility line voltage to the inverter line voltage.
- 3.1.2. **Stand-by Method.** The stand-by method shall set upper and lower control limits for the utility line power. If the utility line voltage falls above or below the upper or lower control limits, then the BBU system will transfer power from the utility line voltage to the inverter line voltage.
- 3.1.3. **Continuous Operating Mode, Double Conversion Method.** The continuous method supplies the cabinet with inverter line voltage at all times. This method requires the disabling of buck and boost functions.
- 3.2. **System Capabilities.** The BBU system shall be capable of providing 1400W peak load, with a minimum of 80% inverter efficiency, for at least 10 seconds.

The BBU system shall be capable of providing 700W signal operation load for a minimum of 4 hours, and then switching to and providing 300W signal flash load for an additional 2 hours minimum, when batteries are fully charged.

When the BBU system is running on battery power, the inverter/charger shall be capable of allowing the voltage at which the transition from normal operating load to flash mode occurs (usually 47.5V) to be selected by a user, via relay contacts and connection points on the front panel of the inverter/charger.

The transfer time allowed, from disruption of normal utility line voltage to stabilized inverter line voltage from batteries, shall be less than 65 milliseconds. The same allowable transfer time shall also apply when switching from inverter line voltage to utility line voltage.

The BBU system shall bypass utility line voltage whenever the utility line voltage is outside of the manufacturer's default, or a user-programmed voltage range, $\pm 2\text{VAC}$.

When the utility line power has been restored to a normal operating voltage for more than a user defined setting (default 30 seconds), the BBU system shall transfer from inverter line voltage to utility line voltage. The BBU system shall be equipped to prevent a malfunction feedback to the cabinet or from feeding back to the utility service.

The BBU system shall be compatible with TS1, TS2 and Model 170/2070 controllers and cabinet components for full run-time operation.

Unless the plans indicate otherwise, provide a BBU in an external battery cabinet. When indicated by the plans, provide a BBU system that can be shelf-mounted in NEMA TS-1 and TS-2 cabinets, or rack-mounted for Model 170/2070 332 cabinets. Provide a manual bypass that is capable of shelf mounting or that can be attached to the side of the signal cabinet. Provide interconnect cables that are no less than 10 ft. in length.

Relay contact wiring for each set of NO/NC relay contact closure terminals shall be no less than 6 feet long and #18 AWG wire. Use manufacturer recommendations for size of wire for any cables lengths greater than 10 feet.

The BBU system shall have lightning surge protection compliant with IEEE/ANSI C.62.41 latest edition and meeting all current UL1449 standards. Lightning surge protection shall be provided to the utility line voltage coming into the inverter/charger. The surge protection device shall be easily accessible and mounted externally from the inverter/charger.

The BBU system, including batteries and hardware, shall be easily replaceable and shall not require any special tools for installation.

The BBU system shall operate in automatic "fail-safe" mode. Should a breaker trip on the inverter/charger and/or the power transfer switch, the system will automatically operate from utility line power and bypass the BBU system.

As stated above, in addition to the inverter/charger, the BBU shall be provided with both an external manual bypass switch and either an external automatic transfer switch or external automatic bypass switch.

The BBU system shall be capable of logging up to 100 events. Events shall date- and time-stamp faults with utility line voltage and battery voltages. At the minimum, the BBU system shall log an event when:

- the utility line voltage falls above or below the upper or lower control limits,
- the BBU system automatically switches to battery power, and
- when self-monitoring BBU system components fail.

3.3. **Displays, Controls, Diagnostics and Maintenance.** The BBU system shall include a front panel display. All applicable programmable functions of the operational methods described in this specification shall be viewable from the front panel display.

All events described in Section 3.2, "System Capabilities" shall be viewable from the front panel display.

The BBU system software shall be programmable from the front panel of the inverter/charger by means of a keyboard or momentary buttons allowing user to step through menu driven software.

A 10/100 Ethernet port shall be provided on the front panel of the inverter/charger.

A RS232 port shall be provided on the front panel of the inverter/charger.

The BBU system software shall be provided for the operational needs of the BBU system. The user/operator shall be able to access all system software via the Ethernet and RS232 ports on the front panel of the inverter/charger. The user shall be able to read logged events and change programmable parameters from the keyboard, laptop or local area network via the Ethernet port.

System software shall be upgradeable via the RS232 port on the front panel of the inverter/charger.

- 3.4. **Inverter/Charger.** The inverter/charger is the unit that provides the voltage regulation; power conditioning of utility line power; convert the DC voltage input into 120 VAC output for the traffic signal cabinet to operate; provides emergency backup power upon loss of utility power and provides for temperature compensated battery charging. As a minimum the inverter/charger shall be rated for 1400 watts. Provide a minimum of 6 sets of normally open (NO) and normally closed (NC) single-pole double-throw dry contact relay closures on the front face of the inverter/charger and labeled so as to identify each contact. The relay closures shall consist a set of NO/NC contact closures that shall be energized whenever the unit switches to battery power (contact shall be labeled or marked as "On Battery" or equivalent) and a second set of NO/NC contact closures shall be energized whenever the battery approaches 40% remaining capacity (contact shall be labeled or marked as "Low battery" or equivalent), which will determine when the unit will switch from normal operation to flash. A third set of NO/NC contact closures shall be energized after a user settable time after the unit switches to battery power. The contact may be labeled "Timer. The remaining relays shall be user definable.

Operating temperature range for both the inverter/charger and power transfer relay shall be -34°C to +74°C. When battery power is used, the BBU system output voltage shall be between 110VAC and 125VAC, pure sine wave output, $\leq 3\%$ THD, 60Hz ± 3 Hz.

- 3.5. **Manual Bypass Switch.** The manual bypass switch shall be provided as a separate unit external to the inverter/charger unit. The manual bypass switch shall consist of housing, two position switch, terminal blocks, internal wiring, service outlet, circuit breakers and mounting hardware. All components shall be rated at a minimum of 240VAC / 30 amp. Provide the manual bypass switch with # 8 terminal blocks. The manual bypass switch shall be 2 position and allow the user to switch utility line power directly to the cabinet service panel. The switch positions will provide the following functions. In the "Bypass" position the inverter is bypassed, utility power is removed from the BBU and passed directly to the signal power panel. In the "UPS" position the inverter / switch is powered and the signal circuits are supplied by the output of the inverter. When the manual bypass switch is in the "Bypass" position the user may replace the automatic bypass switch (or transfer switch) and the inverter/charger without interrupting power to the intersection. Provide the manual bypass switch with over current protection (20 Amp circuit breaker).

- 3.6. **Power Transfer Switch.** These requirements are for BBU systems provided with a power transfer switch. The power transfer switch will operate such that the inverter/charger input and cabinet power panel are supplied with power from the utility line, in the event that the utility line power is lost or requires conditioning (buck or boost) the power transfer switch will automatically connect the inverter/charger output to the cabinet power panel such that the inverter/charger output provides the power. In the event of inverter/charger failure, battery failure, or complete battery discharge, the power transfer shall revert to the NC (de-energized) state, where utility line power is connected to the cabinet service panel.

All wire to the power transfer switch from the manual bypass switch, to and from the inverter/ charger and from the manual bypass switch to utility power service shall be sized accordingly with system requirements.

- 3.7. **Automatic Bypass Switch.** These requirements are for BBU systems provided with an automatic bypass switch. The automatic bypass switch will operate such that the inverter/charger input is supplied with power

from the utility line and the cabinet power panel is supplied with power from the output of the inverter/charger. In the event of inverter/charger failure, battery failure, or complete battery discharge, or other loss of power from the output of the inverter/charger, the automatic bypass switch shall revert to the NC (de-energized) state, where utility line power is connected to the cabinet service panel.

3.8. **Batteries.** Provide batteries from the same manufacturer/vendor of the BBU system.

Individual batteries shall be 12V type, and shall be easily replaceable and commonly available for purchase by common off-the-shelf equivalent.

Batteries shall be sized and rated to operate a 700W load for 4 hours (normal operation) followed by a 300W load for 2 hours (flash operation) for a total of 6 hours.

Battery configuration shall consist of 12V batteries arranged for total voltages of 36V, 48V, 60V, 72V, 84V or 96V.

Batteries shall be deep-discharge, sealed prismatic lead-calcium based, valve-regulated maintenance-free batteries.

Batteries shall operate over a temperature range of -34°C to +74°C.

Batteries shall indicate maximum recharge data and recharging cycles, and manufacturer defaults on the inverter/charger shall not allow the recharging process to exceed the batteries maximum values.

Battery interconnect wiring shall connect to the inverter unit via modular harness with red and black cabling that terminates into a typical power pole style connector. Harness shall be equipped with mating power flag style connectors for batteries and a single insulated plug-in style connection to inverter/charger unit. Harness shall allow batteries to be quickly and easily connected in any order and shall be keyed to ensure proper polarity and circuit configuration. A fusible link or device sized accordingly with system requirements and to protect against currents exceeding each battery current rating shall be provided within 3 inches of the negative and positive leads of each battery. Fusible links shall be insulated stranded wire.

Insulated covers shall be provided at the connection points (post) as to prevent accidental shorting.

Battery cables provided to connect battery to battery harness main cable shall be a minimum of 18 in. or long enough to accommodate the battery covers provided with the battery ground box, whichever is longer. Battery harness shall be sized accordingly with system requirements.

3.9. **Battery Monitoring System.** The BBU system shall use a temperature-compensated battery charging system. The charging system shall compensate over a range of 2.5 – 4.0 mV/°C per cell.

The temperature sensor shall be used to monitor the temperature and regulate the charge rate of the batteries. Unless required otherwise by the plans the temperature sensor wire shall be as follows:

- 8 feet long if external side-mounted cabinet is attached to existing controller cabinet.
- 8 feet long if batteries are housed in traffic signal base used for cabinet foundation and batteries are stored on shelf within base.
- 8 feet long if stand-alone cabinet is used.

Should the temperature sensor fail, the inverter/charger shall not allow the BBU system to overcharge the batteries. The BBU system shall provide an alarm should the temperature sensor fail.

Recharge time for the batteries to obtain 80% or more of full battery charge capacity shall not exceed 20 hours at 21°C (70°F).

Batteries shall not be charged when battery temperature exceeds 50°C.

The BBU system shall monitor battery strings within a system and set a fault indicator if battery voltage falls below normal operating voltage.

- 3.10. **Battery Housing.** Unless plans require otherwise, project an external battery cabinet or stand-alone BBU/battery cabinet as specified below.

- 3.10.1. **External Battery Cabinet.** The external cabinet shall be NEMA type 3R all-aluminum with stainless-steel hardware, or approved equivalent. The external cabinet shall be designed to attach on the side of a TS2 size 6 base-mount cabinet. The batteries, inverter, transfer switches, manual bypass and all associated hardware shall be housed in the external cabinet.

The external cabinet shall be equipped with proper ventilation, electric fan, and air filter in accordance with TS2 standards.

External cabinets will be equipped with a door opening to the entire cabinet. The door shall be attached to the cabinet with a full length stainless steel piano hinge or four, two-bolts per leaf, hinges. The door shall be provided with the same latch and lock mechanism as required for standard traffic signal cabinet. In addition, a padlock clasp will be provided.

When using battery ground boxes, an external cabinet is required for the non-battery components. .

- 3.10.2. **Stand-Alone BBU/Battery Cabinet.** When required for installation by the plans a stand-alone cabinet in accordance with the following shall be provided.

The stand-alone cabinet shall conform to all the specifications of the External BBU/Battery Cabinet, except that it will not mount to the controller cabinet. The stand-alone cabinet shall be designed to attach to a concrete pad.

- 3.11. **Concrete Pad.** Provide a Class B concrete pad as a foundation for stand-alone cabinets of the size shown in the plans. For external cabinets, extend the controller foundation to provide a class B concrete pad under the external cabinet of the size shown in the plans.

- 3.12. **Documentation.** Operation and maintenance manuals shall be provided. The operation manual shall include a block diagram schematic of all system hardware components. The manual shall include instructions for programming and viewing software features. The manual shall include all uploading/downloading (communications protocol) requirements via RS232 or Ethernet port.

Board level schematics shall be provided when requested.

Battery documentation and replacement information shall be provided.

- 3.13. **Testing.** The Department reserves the right to do testing on BBU systems to ensure Quality Assurance on unit before installation and random sampling of units being provided to the State. BBU systems that fail will be taken off the Qualified Products List (QPL).

Department QPL testing procedures will check compliance with all the criteria of this specification including the following:

- Event logging for fault/alarm conditions
- Demonstrated use of one or more of the operating methods described in Section 3.1., "Method of Operation."
- Testing of ability to power a 700W load for 4 hours, transfer to flash mode and power a 300W load for 2 additional hours, at an ambient temperature of +25°C.
- Testing of all components in environmental chamber (temperature ranges from -30°C to +74°C) following NEMA TS2 2003 standards, Section 2.

- 3.14. **Warranty, Maintenance and Support.** Provide a BBU containing a warranty that requires the manufacturer to replace failed BBUs when non-operable due to defect in material or workmanship within five years of date of purchase from manufacturer. Supply a BBU with no less than 95% of the manufacturer's warranty remaining on the date that the BBU is installed and begins operating. The replacement BBU must meet requirements of this specification. The Contractor will handle all warranty issues until the date of final acceptance.

Batteries shall be warranted for full replacement for 5 years. Batteries shall be defined as bad if they are not able to deliver 80% of battery rating.

4. MEASUREMENT

This Item will be measured by each BBU system installed.

5. PAYMENT

The work performed and materials furnished in accordance with this Item and measured as provided under "Measurement" will be paid for at the unit price bid for "BBU System" of the type (type of BBU cabinet) specified. This price is full compensation for furnishing, installing, and testing the completed installation, BBU system and associated equipment, mounting hardware, class B concrete pad, software, conduit, conductors; and equipment, labor, tools; and incidentals.

Special Specification 6083

Video Imaging and Radar Vehicle Detection System



1. DESCRIPTION

This specification sets forth the minimum requirements for a system that detects vehicles on a roadway using a multi-sensor detection system.

The multi-sensor system must utilize 2 different sensors of different technologies, video imaging and radar, to detect and track licensed and unlicensed vehicles at distances up to 600 ft. The sensor system must fuse vehicle information from the 2 sensors to provide highly accurate and precise detection for special or advanced applications.

The multi-sensor system must use a primary detector rack mounted processor to interface with the traffic control cabinet. The module must process information from both video imaging and radar sensors simultaneously in real-time.

1.1. System Configurations. The multi-sensor detection system (MSDS) must consist of up to 2 video cameras and radar units, detection processors (DP) capable of processing from 1 to 2 intersection approaches, output extension modules, surge suppressors, a setup tool and a pointing device.

1.2. Available System Configurations. The MSDS will be deployed at locations where site conditions and roadway geometry vary. The MSDS system may also be deployed at locations where existing cabinets or equipment exist. Existing site configurations will dictate the availability of cabinet space and MSDS usage.

The proposed MSDS must be available in various configurations to allow maximum deployment flexibility. Each configuration must have an identical user interface for system setup and configuration. The communications protocol to each configuration must be identical and must be hardware platform independent. The proposed MSDS must have multiple configurations available for deployment in accordance with Table 1.

Table 1
MSDS Configuration

Description	No. of Multi-Sensor Inputs	No. Video Outputs	Mounting Configuration	Power Supply Requirements
Single-Channel Rack Mounted	1	1	Rack Mount (Type 170 or NEMA TS-1, TS-2 Racks)	12 or 24 VDC Power from Rack
Dual-Channel Rack Mounted	2	1	Rack Mount (Type 170 or NEMA TS-1, TS-2 Racks)	12 or 24 VDC Power from Rack

1.3. System Software. The system must include software that detects vehicles in multiple lanes. Video imaging detection zones must be defined using only an on-board video menu and a pointing device to place the zones on a video image. Up to 24 video detection zones per camera view must be available. Two additional trigger zones for the radar sensor must be available and be configurable by using the same system setup menu on the DP. A separate computer must not be required to program the detection zones. A portable **setup tool must be available for sensor alignment and adjustment of camera's field of view and focus menu** on the DP. A separate computer must not be required to program the detection zones. A portable setup tool **must be available for sensor alignment and adjustment of camera's field of view and focus.**

2. MATERIALS

2.1. Multi-Sensor Detection System Hardware.

The MSDS hardware must consist of the following 4 elements:

- Video imaging camera sensor
- Radar sensor
- Sensor data combiner
- Detection processor

The MSDS must be made in the U.S.A. in compliance with FTA “Buy America” regulations.

2.2. Video Imaging Camera Sensor. To accommodate deployment flexibility, the MSDS camera sensor must be compatible with all DP platforms identified in Table 1. The MSDS camera sensor must be supplied by the MSDS manufacturer.

The advanced camera enclosure must utilize Indium Tin Oxide (ITO) technology for the heating element of the front glass. The transparent coating must not impact the visual acuity and must be optically clear.

Cable terminations at the data combiner for video and power must not require crimping or special tools.

The camera sensor must allow the user to set the focus and field of view via Wi-Fi connectivity.

The camera must produce a useable video image of the bodies of vehicles under all roadway lighting conditions, regardless of time of day. The minimum range of scene luminance over which the camera must produce a useable video image must be the minimum range from nighttime to daytime, but not less than the range of 1.0 to 10,000 lux.

The camera electronics must include automatic gain control (AGC) to produce a satisfactory image at night.

The imager luminance signal to noise ratio (S/N) must be more than 50 dB with the automatic gain control (AGC) disabled.

The imager must employ 3 dimensional dynamic noise reduction (3D-DNR) to remove unwanted image noise.

The camera imager must employ wide dynamic range (WDR) technology to compensate for wide dynamic outdoor lighting conditions. The dynamic range must be greater than 100 dB.

The camera must be digital signal processor (DSP) based and must use a CCD sensing element and must output color video with resolution of not less than 550 TV lines.

The camera sensor must include an electronic shutter control based upon average scene luminance and must be equipped with an auto-iris lens that operates in tandem with the electronic shutter. The electronic shutter must operate within the range of 1/1 to 1/10,000th sec.

The camera sensor must utilize automatic white balance.

The camera sensor must include a variable focal length lens with variable focus that can be adjusted, without opening up the camera housing, to suit the site geometry by means of a portable interface device designed for that purpose and manufactured by the detection system supplier.

The horizontal field of view must be adjustable from 4.6° to 53.6°. This camera configuration may be used for the majority of detection approaches in order to minimize the setup time and spares required by the user. The lens must be a 12x zoom lens with a focal length of 3.7 to 44.0 mm.

The lens must also have an auto-focus feature with a manual override to facilitate ease of setup.

The camera must incorporate the use of preset positioning that store zoom and focus positioning information. The camera must have the capability to recall the previously stored preset upon application of power.

The camera must be housed in a weather-tight sealed enclosure conforming to IP-67 specifications. The housing must allow the camera to be rotated to allow proper alignment between the camera and the traveled road surface.

The camera enclosure must be equipped with a sunshield. The sunshield must include a provision for water diversion to prevent water from flowing in the camera's field of view.

The camera enclosure must be design so that the pan, tilt and rotation of the camera assembly can be accomplished independently without affecting the other settings.

The camera enclosure must include a proportionally controlled Indium Tin Oxide heater design that maximizes heat transfer to the lens. The output power of the heater must vary with temperature, to assure proper operation of the lens functions at low temperatures and prevent moisture condensation on the optical faceplate of the enclosure.

The glass face on the front of the enclosure must have an anti-reflective coating to minimize light and image reflections.

When mounted outdoors in the enclosure, the camera must operate in a temperature range from -34°C to +74°C and a humidity range from 0 to 100% RH. Measurement of satisfactory video must be based upon DP system operation.

The camera sensor must acquire its power from the sensor data combiner.

Recommended camera placement height must be between 18 and 33 ft. (or 6 and 10 m) above the roadway, and over the traveled way on which vehicles are to be detected. For optimum detection the camera must be centered above the traveled roadway. The camera must view approaching vehicles at a distance not to exceed 350 ft. for reliable detection (height to distance ratio of 10:100). Camera placement and field of view (FOV) must be unobstructed and as noted in the installation documentation provided by the supplier.

The video signal must be fully isolated from the camera enclosure and power cabling

A weather-proof protective cover must be provided to protect all terminations at the camera.

2.3. Radar Sensor. The radar sensor must operate in the 24 GHz frequency band and must operate on 1 of 7 available enumerated channels that is user selectable.

The radar detection range must be 600 ft. minimum, +/- 5%.

The radar sensor must be able to track up to 20 independent objects simultaneously.

Object speed detection must be within the range of 0 and 150 mph +/- 1.0 mph.

The radar sensor must be able to detect vehicles in 1 to 4 traffic lanes.

The radar sensor must be housed in a weather-tight sealed enclosure conforming to IP-67 specifications. The housing must allow the radar to be adjusted to allow proper alignment between the sensor and the traveled road surface.

When mounted outdoors in the enclosure, the radar must operate in a temperature range of -34°C to +74°C and a humidity range from 0 to 100% RH.

The radar sensor must communicate with the sensor data combiner.

The radar sensor must acquire its power from the sensor data combiner.

- 2.4. Multi-Sensor Assembly. Both camera and radar sensors must be housed in an overall, single enclosure assembly.
- The overall size of the multi-sensor enclosure must not exceed 14 in. x 15 in. x 17 in.
- The overall weight of the multi-sensor unit must not exceed 11 lb.
- The effective projected area (EPA) must not exceed 2.0 sq. ft.
- The maximum power consumption for the multi-sensor assembly must be less than 10W typical, 20W peak.
- 2.5. Sensor Data Combiner. A sensor data combiner that combines sensor information from both video and radar sensors must be employed.
- The sensor data combiner must supply primary power to each sensor unit.
- The sensor data combiner must facilitate digital communications between the sensor data combiner and each of the sensor units.
- The sensor data combiner must get its primary power from an AC power source using industry standard 3-conductor cabling.
- The sensor data combiner must communicate with the detection processor using a single coax cable. Both video imaging and radar data must use the single coax cable.
- The sensor data combiner must also employ industry standard Wi-Fi connectivity for remote sensor system setup using a mobile programming device such as a netbook or tablet computer. Video camera and radar sensor must be able to be configured independently.
- The sensor data signal must be fully isolated from the mechanical enclosure and power cabling.
- Cable terminations at the sensor data combiner must not require crimping tools.
- The sensor data combiner must be housed in a weather-tight sealed enclosure conforming to IP-67 specifications.
- 2.6. Detection Processor (DP). Each sensor input must accept RS170 (NTSC) or CCIR (PAL) signals from an external video source. The interface connector must be BNC type and must be located on the front of the processing unit. The sensor input must have the capability to be terminated into 75 ohms or high impedance (Hi-Z) using dip switches or software control from the user menu. The sensor input must also facilitate the data from the radar sensor.
- A LED indicator must be provided to indicate the presence of the sensor signal. The LED must illuminate upon valid sensor synchronization and turn off when the presence of a valid sensor signal is removed.
- One video output must be provided. The video output must be RS170 or CCIR compliant and must pass through the input video signal.
- For multi-channel video input configurations, a momentary push-button must be provided on the front panel to cycle through each input video channel. In the absence of a valid sensor signal, the channel must be skipped and the next valid sensor signal must be switched. The real time video output must have the capability to show text and graphical overlays to aid in system setup. The overlays must display real-time actuation of detection zones upon vehicle detection or presence. Overlays must be able to be turned off by the user. Control of the overlays and sensor switching must also be provided through the serial communications port. The video output interface connector must be positive locking BNC type. Friction type (e.g. RCA type) connectors must not be allowed.

A serial communications port must be provided on the front panel. The serial port must be compliant with EIA232 electrical interfaces and must use a DB9 type connector mounted on the front panel of the DP. The serial communications interface must allow the user to remotely configure the system and to extract calculated vehicle and roadway information. The interface protocol must be documented or interface software must be provided. The interface protocol must support multi-drop or point-to-multipoint communications. Each MSDS must have the capability to be addressable. The DP must support data rates of 1200 to 230,400 bps, inclusive.

Open collector (contact closure) outputs must be provided. Four open collector outputs must be provided for the single or dual channel rack-mount configuration. Additionally, the DP must allow the use of extension modules to provide up to 24 open collector contact closures per camera input. Each open collector output must be capable of sinking 30 mA at 24 VDC. Open collector outputs will be used for vehicle detection indicators as well as discrete outputs for alarm conditions. The DP outputs must be compatible with industry standard detector racks assignments.

Logic inputs such as delay/extend or delay inhibit must be supported through the appropriate detector rack connector pin or front panel connector in the case of the I/O module. For DPs and extension modules, 4 inputs must be supported via detector rack interface. The I/O module must accommodate 8 inputs through a **15-pin "D" connector**.

Detection status LEDs must be provided on the front panel. The LEDs must illuminate when a contact closure output occurs. Rack-mounted detection processors must have a minimum of 4 LEDs. Rack-mounted extension modules must have 2, 4 or 8 LEDs (depending upon extension module type) to indicate detection.

The front panel of the DP must have detector test switches to allow the user to manually place calls on each DP output channel. The test switch must be able to place either a constant call or a momentary call depending on the position of the switch.

A USB mouse port must be provided on the front panel of the rack mount detection processing unit. The mouse port must not require special mouse software drivers. The mouse port must be used as part of system setup and configuration. A mouse must be provided with each detection processor.

Extension modules must be connected to the DP by an 8-wire twisted-pair cable with modular RJ45 connectors. DP and EM communications must be accommodated by methods using differential signals to reject electrically coupled noise.

Extension modules (EM) must be available to eliminate the need of rewiring the detector rack, by enabling the user to plug an extension module into the appropriate slot in the detector rack to provide additional open collector outputs. The extension module must be available in both 2 and 4 channel configurations. EM configurations must be programmable from the DP. A separate I/O module with 32 outputs through a 37-pin **"D" connector on the front panel and 8 inputs through a 15-pin "D" connector using an external wire harness** for expanded flexibility must also be available.

The DP and EM must be specifically designed to mount in a standard detector rack, using the edge connector to obtain power, provide contact closure outputs and accept logic inputs (e.g. delay, extend). No adapters must be required to mount the DP or EM in a standard detector rack. Detector rack rewiring must not be required.

The DP must utilize non-volatile memory technology to store on-board firmware and operational data.

The DP must enable the loading of modified or enhanced software through the EIA232 or USB port (using a USB thumb drive) and without modifying the DP hardware.

The DP and EM must be powered by 12 or 24 VDC. DP and EM modules must automatically compensate for either 12 or 24 VDC operation. DP power consumption must not exceed 7.5W. The EM power consumption must not exceed 3W.

The DP must operate satisfactorily in a temperature range from -34°C to +74°C and a humidity range from 0 to 95% RH, non-condensing as set forth in NEMA specifications.

An Edco CX-06M video surge suppresser must be provided for each sensor input. The surge suppresser must be appropriately grounded to the cabinet ground rod using 14 AWG minimum.

- 2.7. System Software. Detection zones must be programmed via an on board menu displayed on a video monitor and a pointing device connected to the DP. The menu must facilitate placement of detection zones and setting of zone parameters or to view system parameters. A separate computer must not be required for programming detection zones or to view system operation.

The DP must store up to 3 different detection zone patterns in non-volatile memory. The DP can switch to any one of the 3 different detection patterns within 1 sec. of user request via menu selection with the pointing device. Each configuration must be uniquely labeled and able to be edited by the user for identification. The currently active configuration indicator must be displayed on the monitor.

The DP must detect vehicles in real time as they travel across each detection zone.

The DP must accept new detection patterns from an external computer through the EIA232 port when the external computer uses the correct communications protocol for downloading detection patterns. A **Windows™**-based software designed for local or remote connection and providing video capture, real-time detection indication and detection zone modification capability must be provided with the system.

The DP system must have the capability to automatically switch to any one of the stored configurations based on the time of day which must be programmable by the user.

The DP must send its detection patterns to an external computer through the EIA232 port when requested when the external computer uses the appropriate communications protocol for uploading detection patterns.

The DP must default to a safe condition, such as a constant call on each active detection channel, in the event of unacceptable interference or loss of the sensor signal.

The system must be capable of automatically detecting a low-visibility condition such as fog and respond by placing all effected detection zones in a constant call mode. A user-selected alarm output must be active during the low-visibility condition that can be used to modify the controller operation if connected to the appropriate controller input modifier(s). The system must automatically revert to normal detection mode when the low-visibility condition no longer exists.

Up to 24 detection zones per camera input must be supported and each detection zone can be sized to suit the site and the desired vehicle detection region.

The DP must support 2 independent trigger points for radar outputs for dilemma zone applications.

The DP must provide up to 24 open collector output channels per sensor input using one or more extension modules.

A single detection zone must be able to replace multiple inductive loops and the detection zones must be OR'ed as the default or may be AND'ed together to indicate vehicle presence on a single approach of traffic movement.

Placement of detection zones must be done by using only a pointing device, and a graphical interface built into the DP and displayed on a video monitor, to draw the detection zones on the video image from each video camera. No separate computer must be required to program the detection zones.

When a vehicle is detected within a detection zone, a visual indication of the detection must activate on the video overlay display to confirm the detection of the vehicle for the zone.

Detection must be at least 98% accurate in good weather conditions, with slight degradation possible under adverse weather conditions (e.g. rain, snow, or fog) which reduce visibility.

Detection accuracy is dependent upon site geometry, camera placement, camera quality and detection zone location, and these accuracy levels do not include allowances for occlusion or poor video due to camera location or quality.

The DP must provide dynamic zone reconfiguration (DZR). DZR enables normal operation of existing detection zones when one zone is being added or modified during the setup process. The new zone configuration must not go into effect until the configuration is saved by the operator.

Detection zone setup must not require site specific information such as latitude and longitude to be entered into the system.

The DP must process the video input from each camera at 30 frames per second. Multiple camera processors must process all video inputs simultaneously.

The DP must output a constant call during the background learning period of no more than 3 min.

Detection zone outputs must be configurable to allow the selection of presence, pulse, extend, and delay outputs. Timing parameters of pulse, extend, and delay outputs must be user definable between 0.1 to 25 sec.

Up to 6 video detection zones per sensor input must have the capability to count the number of vehicles detected. The count value must be internally stored for later retrieval through the EIA232 port. The zone must also have the capability to calculate and store average speed and lane occupancy at bin intervals of 10 sec., 20 sec., 1 min., 5 min., 15 min., 30 min. and 60 min. One radar sensor zone must also count vehicles, calculate, and store the average speed and lane occupancy across the approach.

In addition to the count type zone, the DP must be able to calculate and/or acquire average speed and lane occupancy using both video and radar sensors. These values must be stored in non-volatile memory for later retrieval.

The DP must have an “advance” zone type where detection outputs to the traffic controller is compensated for angular occlusion and distance.

The DP must employ color overlays on the video output.

The DP must have the ability to show phase status (green, yellow, or red) for up to 8 phases. These indications must also be color coded.

The user must have the ability to enable or disable the display of the phase information on the video output.

The DP must have the capability to change the characteristics of a detection zone based on external inputs such as signal phase. Each detection zone must be able to switch from one zone type (i.e. presence, **extension, pulse, etc.) to another zone type based on the signal state. For example, a zone may be a “count” zone when the phase is green but change to a “presence” zone type when the phase is not green.**

Another application would be zone type of “extension” when the signal phase is green and then “delay” when red.

For alpha numeric user inputs, the DP must utilize a virtual keyboard on the video overlay system to ease user input. The virtual keyboard must use the standard QWERTY keyboard layout.

The DP must aid the user in drawing additional detection zones by automatically drawing and placing zones at appropriate locations with only a single click of the mouse. The additional zone must utilize geometric

extrapolation of the parent zone when creating the child zone. The process must also automatically accommodate lane marking angles and zone overlaps.

When the user wishes to modify the location of a zone, the DP must allow the user move a single zone, multiple zones or all zones simultaneously.

When the user wishes to modify the geometric shape of the zone, the DP must allow the user to change the shape by moving the zone corner or zone sides.

On screen zone identifiers must be modifiable by the user. The user must be allowed to select channel output assignments, zone type, input status, zone labels or zone numbers to be the identifier.

For multiple camera input DPs, the user must have the ability to enable automatic video output switching. The dwell time for each sensor input must be user programmable.

For radar sensor zones, the output can be triggered by presence of a vehicle only or by presence of a vehicle above a user-defined speed threshold.

3. CONSTRUCTION

The coaxial cable to be used between the multi-sensor assembly and the DP in the traffic cabinet must be Belden 8281. This cable must be suitable for installation in conduit or overhead with appropriate span wire. BNC plug connectors must be used where applicable. The coaxial cable, BNC connector, and crimping tool must be approved by the supplier of the MSDS, and the manufacturer's instructions must be followed to ensure proper connection.

The power cabling must be 16 AWG three-conductor cable with a minimum outside diameter of 0.325 in. and a maximum diameter of 0.490 in. The cabling must comply with the National Electric Code, as well as local electrical codes. Cameras may acquire power from the luminaire if necessary.

The MSDS must be installed by factory-certified installers as recommended by the supplier and documented in installation materials provided by the supplier. Proof of factory certification must be provided.

3.1. Testing.

The installed assembly will be field tested prior to being placed into service to ensure all components are functioning as described herein.

The supplier must provide a limited 5 yr. warranty on the MSDS. During the warranty period, technical support must be available from the supplier via telephone within 4 hr. of the time a call is made by a user, and this support must be available from factory-certified personnel or factory-certified installers. During the warranty period, updates to DP software must be available from the supplier without charge.

The supplier must maintain an adequate inventory of parts to support maintenance and repair of the MSDS. These parts must be available for delivery within 30 days of placement of an acceptable order at the supplier's then current pricing and terms of sale for said parts.

The supplier must maintain an ongoing program of technical support for the MSDS. This technical support must be available via telephone, or via personnel sent to the installation site upon placement of an acceptable order at the supplier's then current pricing and terms of sale for onsite technical support services.

Installation or training support must be provided by a factory-authorized representative and must be a minimum IMSA-Level II Traffic Signal Technician certified.

4. MEASUREMENT

This Item will be measured by each unit shown in the plans furnished, installed, made fully operational, and tested in accordance with this special specification or as directed.

5. PAYMENT

The work performed and materials furnished in accordance with this Item and measured as provided under **“Measurement” will be paid for at the unit price bid for “Video Imaging and Radar Vehicle Detection System.”** This price will be full compensation for furnishing, installing, internal electrical conductors, connectors and mounting hardware; and for all labor, tools, equipment, testing documentation and incidentals necessary to complete the work.

Special Specification 6185

Truck Mounted Attenuator (TMA) and Trailer Attenuator (TA)



1. DESCRIPTION

Furnish, operate, maintain and remove upon completion of work, Truck Mounted Attenuator (TMA) or Trailer Attenuator (TA).

2. MATERIALS

Furnish, operate and maintain new or used TMAs or TAs. Assure used attenuators are in good working condition and are approved for use. A list of approved TMA/TA units can be found in the Department's Compliant Work Zone Traffic Control Devices List. The host vehicle for the TMA and TA must weigh a minimum of 19,000 lbs. Host vehicles may be ballasted to achieve the required weight. Any weight added to the host vehicle must be properly attached or contained within it so that it does not present a hazard and that proper energy dissipation occurs if the attenuator is impacted from behind by a large truck. The weight of a TA will not be considered in the weight of the host vehicle but the weight of a TMA may be included in the weight of the host vehicle. Upon request, provide either a manufacturer's curb weight or a certified scales weight ticket to the Engineer.

3. CONSTRUCTION

Place or relocate TMA/TAs as shown on the plans or as directed. The plans will show the number of TMA/TAs needed, for how many days or hours, and for which construction phases.

Maintain the TMA/TAs in good working condition. Replace damaged TMA/TAs as soon as possible.

4. MEASUREMENT

4.1. **Truck Mounted Attenuator/Trailer Attenuator (Stationary).** This Item will be measured by the each or by the day. TMA/TAs must be set up in a work area and operational before a calendar day can be considered measurable. When measurement by the day is specified, a day will be measured for each TMA/TA set up and operational on the worksite.

4.2. **Truck Mounted Attenuator/Trailer Attenuator (Mobile Operation).** This Item will be measured by the hour. The time begins once the TMA/TA is ready for operation at the predetermined site and stops when notified by the Engineer. A minimum of 4 hr. will be paid each day for each operating TMA/TA used in a mobile operation.

5. PAYMENT

The work performed and materials furnished in accordance with this Item and measured as provided under "Measurement" will be paid for at the unit price bid for "Truck Mounted Attenuators/Trailer Attenuators (Stationary)," or "Truck Mounted Attenuators/Trailer Attenuators (Mobile Operation)." This price is full compensation for furnishing TMA/TA: set up; relocating; removing; operating; fuel; and equipment, materials, tools, labor, and incidentals.

This page intentionally left blank.