

**FINAL PLANS**

NAME OF CONTRACTOR: \_\_\_\_\_

DATE OF LETTING: \_\_\_\_\_

DATE WORK BEGAN: \_\_\_\_\_

DATE WORK COMPLETED: \_\_\_\_\_

DATE WORK ACCEPTED: \_\_\_\_\_

SUMMARY OF CHANGE ORDERS:

STATE OF TEXAS  
DEPARTMENT OF TRANSPORTATION

PLANS OF PROPOSED  
STATE HIGHWAY IMPROVEMENT

STATE PROJECT  
C 0918-00-392  
CSJ: 0918-00-392

VARIOUS ROADWAYS  
VARIOUS COUNTIES

LIMITS: VARIOUS LOCATIONS IN THE DALLAS DISTRICT

FOR THE CONSTRUCTION OF TRAFFIC CONTROL DEVICES  
CONSISTING OF NON-SITE SPECIFIC INSTALLATION OF TRAFFIC SIGNALS

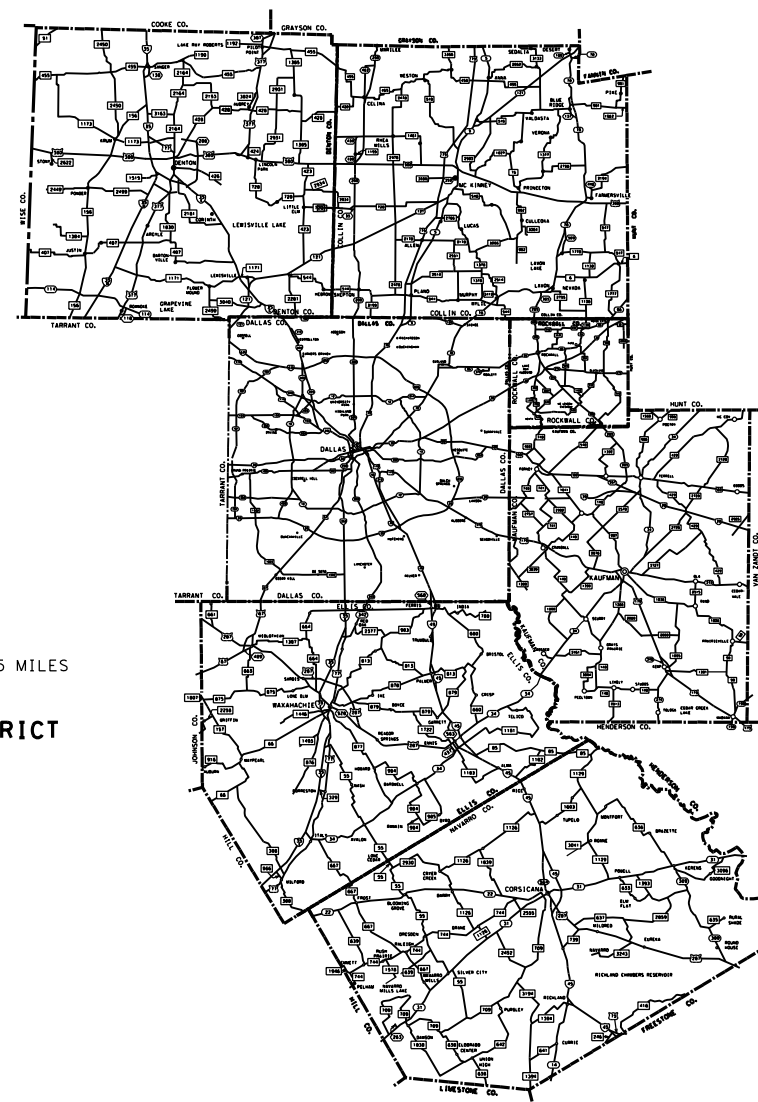

SCALE 0 5 10 15 MILES

DALLAS DISTRICT

WORK WAS COMPLETED ACCORDING  
TO THE PLANS AND CONTRACT.

\_\_\_\_\_, P.E.  
Signature of Registrant & Date

EQUATIONS: NONE  
EXCEPTIONS: NONE  
RAILROAD CROSSINGS: NONE

FED. RD. DIV. NO.	STATE PROJECT NO.		HIGHWAY NO.
6	C 0918-00-392		VA
STATE	DISTRICT	COUNTY	SHEET NO.
TEXAS	DALLAS	DALLAS, ETC.	1
CONTROL	SECTION	JOB	
0918	00	392	

**NOTE:**

SPECIFICATIONS ADOPTED BY THE TEXAS DEPARTMENT OF TRANSPORTATION, SEPTEMBER 1, 2024, AND THE CONTRACT PROVISIONS LISTED AND DATED AS FOLLOWS SHALL GOVERN ON THIS PROJECT: SPECIAL LABOR PROVISIONS FOR STATE PROJECTS (000-005)

REGISTERED ACCESSIBILITY SPECIALIST (RAS) INSPECTION  
REQUIRED. TDLR NO: TABS2024022305

TEXAS DEPARTMENT OF TRANSPORTATION

SUBMITTED FOR LETTING 7/16/2024  
DocuSigned by:  
*Eyad Fanous*, P.E.  
TRAFFIC DESIGN SUPERVISOR  
7C074158193648D...

APPROVED FOR LETTING 7/16/2024  
DocuSigned by:  
*JEFFREY BUSH*, P.E.  
DIRECTOR OF OPERATIONS  
345B765EB03F406...

# INDEX OF SHEETS

TIME: 7:36:53 AM

DATE: 6/25/2024

FILE: U:\TRAFFIC\_PROJECTS\0918-00-392 Non-Site 9-24\Microstation Files\002 INDEX OF SHEETS.dgn

SHEET	DESCRIPTION
<b><u>I. GENERAL</u></b>	
1	TITLE SHEET
2	INDEX OF SHEETS
3, 3A - 3I	GENERAL NOTES
4, 4A - 4G	ESTIMATE AND QUANTITY SHEET

<b><u>II. TRAFFIC CONTROL PLAN</u></b>	
5 - 6	*WZ(BTS-1 & 2)-13
7	*WZ(RS)-22
8 - 19	*BC(1 - 12)-21
20 - 21	*TCP(2 - 1 & 4)-18
22	*TCP(3 - 4)-13

SHEET	DESCRIPTION
<b><u>III. TRAFFIC ITEMS</u></b>	
23	ELECTRICAL SERVICE DATA
24 - 27	*PED-18
28	*CCCG-22
29 - 30	*REPCP-14
31	*JS-14
32 - 34	*CONSTRUCTION DETAILS FOR SPAN WIRE MOUNTED TRAFFIC SIGNALS (DAL)
35	*TRAFFIC SIGNAL HEAD DETAILS (DAL)
36	*PEDESTRIAN SIGNAL HEAD DETAILS (DAL)
37 - 39	*TSR(3-5)-13
40	*SMD(GEN)-08
41	*SMD(SLIP-1)-08 (DAL)
42 - 43	*SMD(SLIP 2 & 3)-08
44 - 45	*SMA-80(1-2)-12 (DAL)
46 - 48	*DMA-80(1-3)-12 (DAL)
49 - 50	*LMA(1-2)-12 (DAL)
51	*LMA(3)-12
52 - 53	*LMA(4-5)-12 (DAL)
54	*MA-DPD-20
55	*TS-BP-20
56	*MA-D-12 (DAL)
57	*MA-C-12
58	*MA-C(ILSN)-12
59 - 60	*SP-80(1, 2)-12 (DAL)
61	*RFBA-13
62 - 63	*SPRFBA(1, 3)-13
64	*LUM-A-12
65	*CFA-12
66 - 68	*RID(1-3)-20
69 - 72	*RIP(1-4)-19
73	*SNS-95
74	*TS-FD-12
75	*TS-CF-21
76 - 87	*ED(1-12)-14
88 - 89	*LD(1-2)-03
90	*VDZ-04 (DAL)
91	*RVDS-23 (DAL)
92 - 94	*PM(1-3)-22
95	*PM(4)-22A
96 - 97	*RCD(1-2)-22
98	*BLPM-10
99 - 101	*INSTALLATION OF BBU/EVP (DAL)
102 - 103	*RAILROAD REQUIREMENTS FOR NON-BRIDGE CONSTRUCTION PROJECTS
104	*RAILROAD SCOPE OF WORK
105 - 110	*D&OM(1-6)-20

SHEET	DESCRIPTION
<b><u>IV. ENVIRONMENTAL ISSUES</u></b>	
111	*EPIC (DAL)
112 - 113	SWP3 (LESS THAN 1 ACRE)
114 - 116	*EC(9)-16

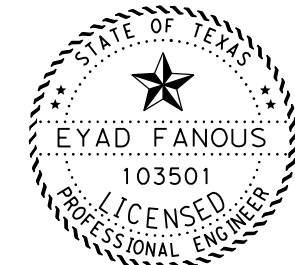

*Eyad Fanous*, P.E. 6/25/2024  
Signature Date

\* THE STANDARD SHEETS SPECIFICALLY IDENTIFIED ABOVE HAVE BEEN SELECTED BY ME OR UNDER MY RESPONSIBLE SUPERVISION AS BEING APPLICABLE TO THIS PROJECT.

Texas Department of Transportation  
© 2024

## INDEX OF SHEETS

DESIGN	FED. RD. DIV. NO.	PROJECT NO.		HIGHWAY NO.
EF	6	(SEE TITLE SHEET)		VA
EF	STATE	DISTRICT	COUNTY	SHEET NO.
CHECK SW	TEXAS	DALLAS	DALLAS, ETC.	<b>2</b>
CHECK	CONTROL	SECTION	JOB	
CMC	0918	00	392	

County: DISTRICTWIDE

Highway: VA

**GENERAL**

Material On Hand will not be considered or accepted for this project.

The construction, operation and maintenance of the proposed project will be consistent with the state implementation plan as prepared by the Texas Commission on Environmental Quality.

The disturbed area for this project, as shown on the plans is 0.0858 acres. However, **the Total Disturbed Area** (TDA) will establish the required authorization for storm water discharges. The TDA of this project will be determined by the sum of the disturbed area in all project locations in the contract, and all disturbed area on all Project-Specific Locations (PSL) located in the project limits and/or within 1 mile of the project limits. The department will obtain an authorization to discharge storm water from the Texas Commission on Environmental Quality (TCEQ) for the construction site as shown on the plans, according to the TDA of the project. The contractor will obtain any required authorization from the TCEQ for the discharge of storm water from any PSL for construction support activities on or off of the project row according to the TDA of the project. When the TDA for the project exceeds 1 acre, provide a copy of the appropriate application of permit (NOI, or Construction Site Notice) to the engineer, for any PSL located in the project limits or within 1 mile of the project limits. Follow the directives and adhere to all requirements set forth in the TCEQ, Texas Pollution Discharge Elimination System, Construction General Permit (TPDES, CGP).

MAXIMUM TOTAL DISTURBED AREA AT ANY GIVEN TIME**				
TYPE OF SIGNALS	DISTURBED AREA*	UNIT	INTERSECTION (EA)	SUBTOTAL
TRAFFIC SIGNAL	0.0429	ACRE	2	0.0858

\*PER INTERSECTION

\*\*BASED ON 2 WORK ORDERS UNDER CONSTRUCTION

Leave all right of way areas undisturbed until actual construction is to be performed in said areas.

Provide the Engineer with a copy of all DBE subcontractor agreements prior to commencing work.

Questions may be submitted via the Letting Pre-Bid Q&A web page. This webpage can be accessed from the Notice to Contractors dashboard located at the following Address: <https://tableau.txdot.gov/views/ProjectInformationDashboard/NoticetoContractors> or Contractor questions on this project are to be addressed to the following individual(s):

Engineer's Email: [Christopher.Blain@txdot.gov](mailto:Christopher.Blain@txdot.gov)

Construction Manager's Email: [Eric.Herman@txdot.gov](mailto:Eric.Herman@txdot.gov)

Construction Record-Keeper's Email: [Anthony.Block@txdot.gov](mailto:Anthony.Block@txdot.gov)

County: DISTRICTWIDE

Highway: VA

All contractor questions will be reviewed by the Engineer or Construction Manager. All questions and any corresponding responses that are generated will be posted through the same Letting Pre-Bid Q&A web page.

The Letting Pre-Bid Q&A web page for each project can be accessed by using the dashboard to navigate to the project you are interested in by scrolling or filtering the dashboard using the controls on the left. Hover over the blue hyperlink for the project you want to view the Q&A for and click on the link in the window that pops up.

**Item 1:**

This is a Non-Site-Specific Contract as defined in Item 1.3.95.

Specific project locations and plan details will be incorporated into this contract by work orders at later dates.

The quantities shown on this contract are for bidding purposes only. The actual quantities will be shown on each work order.

**Item 5:**

Underground utilities owned by the Texas Department of Transportation may be present within the Right-Of-Way on this project. For signal, illumination, surveillance, and communications & control maintained by TxDOT, call the TxDOT Traffic Signal Office (214-320-6682) for locates a minimum of 48 hours in advance of excavation. For irrigation systems, call TxDOT Maintenance Landscape Office (214-320-6636) for locates a minimum of 48 hours in advance of excavation. If city or town owned irrigation facilities are present, call the appropriate department of the local city or town a minimum of 48 hours in advance of excavation. The Contractor is liable for all damages incurred to the above mentioned utilities when working without having the utilities located prior to excavation.

For the project to be deemed complete, permanently stabilize all unpaved disturbed areas of the project with a vegetative cover at a minimum of 70% density for the control of erosion.

Ensure a representative of the Prime Contractor is available on the project site at all times when work is being performed by the Prime Contractor or sub-contractor(s) to receive instructions from the Engineer or authorized Department representative.

Submit all shop drawings, working drawings, or other documents which require review sufficiently in advance of scheduled construction to allow no less than thirty (30) calendar days for review and response.

Locate all utilities, both underground and above ground, in the project area prior to beginning work so that conflicts are avoided.

County: DISTRICTWIDE

Highway: VA

Provide to the Engineer, in addition to any submittals required by the specifications and elsewhere in the general notes, a list of pre-qualified material to be used on the project.

**Item 7:**

Repair or replace any structures and utilities that might have been damaged by negligence or a failure to have utility locates performed.

Perform all electrical work in accordance with the National Electrical Code and Texas Department of Transportation Specifications.

Consult with appropriate electric company representatives according to their respective area to coordinate electrical services installations.

Contractor will be responsible for all costs associated with locating and/or exposing existing utilities. This includes existing utilities that may have been mismarked by the locator and/or utilities that are in the near vicinity of proposed construction. In addition, this includes all costs associated with pot-holing, mechanical vacuuming, hand-digging, etc. as needed to properly locate and protect all existing utilities.

Holiday restrictions – The Engineer may decide that no lane closures or construction operations shall be allowed during the restricted periods listed in the following holiday schedule. TxDOT has the right to lengthen, shorten, or otherwise modify these restricted periods as actual, or expected, traffic conditions may warrant. Working days will not be charged for these restricted periods. No additional compensation will be allowed for these closures (i.e., overhead, delays, stand-by, barricades or any other associated cost impacts).

- New Year’s Eve & Day (5 am on December 31 thru 10:00 pm January 1)
- Easter Holiday weekend (5 am on Friday thru 10:00 pm Sunday)
- Memorial Day weekend (5 am on Friday thru 10:00 pm Monday)
- Independence Day (5 am on July 3 thru 10:00 pm on July 5)
- Labor Day weekend (5 am on Friday thru 10:00 pm Monday)
- Thanksgiving Holiday (5 am on Wednesday thru 10:00 pm Sunday)
- Christmas Holiday (5 am on December 23 thru 10:00 pm December 26)

Holiday restrictions for Independence Day, Thanksgiving Holiday, and the Christmas Holiday may be extended for the “week of” due to the nature of work being performed and the work location at the discretion of the Engineer for safety of the traveling public.

Roadway closures during the following key dates and/or special events are prohibited in Navarro County.

- The University of Texas vs. University of Oklahoma football game (no lane closures beginning 4 hr. prior to the event and ending 3 hr. following event completion).

Roadway closures during the following key dates and/or special events are prohibited in Denton County.

County: DISTRICTWIDE

Highway: VA

- The University of Texas vs. University of Oklahoma football game (no lane closures beginning 4 hr. prior to the event and ending 3 hr. following event completion).
- Texas Motor Speedway – NASCAR Series Races – April and November
- Texas Motor Speedway – INDY Series Races – June and September

The Contractor will plan his work such that no work is ongoing and all lanes of traffic are available for the NASCAR series races at the Texas Motor Speedway starting the Thursday of race week through Sunday. These races are run usually in early April and Mid-November. The Contractor will not be allowed to have any lane closures on the day of the INDY car races, one of which is usually scheduled during the beginning of June and the other is usually scheduled during Mid-September. Scheduled events at Texas Motor Speedway may be reviewed at their website:

<http://www.texasmotorspeedway.com>. All incomplete work activities will need to be shaped up prior to the race events as to pose no hazard to traffic. The above is applicable to each year the work is ongoing. Time will not be charged on these days.

Roadway closures during the following key dates and/or special events are prohibited in Kaufman County.

- The University of Texas vs. University of Oklahoma football game (no lane closures beginning 4 hr. prior to the event and ending 3 hr. following event completion).

Roadway closures during the following key dates and/or special events are prohibited in Collin County.

- The University of Texas vs. University of Oklahoma football game (no lane closures beginning 4 hr. prior to the event and ending 3 hr. following event completion).

Roadway closures during the following key dates and/or special events are prohibited in Ellis County.

Event Restrictions – No Lane Closures that restricts or interferes with traffic will be allowed for the regional events set forth below. TxDOT has the right to lengthen, shorten, or otherwise modify these restrictions as actual traffic conditions may warrant. TxDOT also has the right to modify the list of major events as they are added, renamed, rescheduled, or as warranted.

- National Polka Festival – The event is the last weekend of every May. No lane closures will be allowed without Engineer approval for roadways in or around Ennis, Texas. Please see the event website for specific dates. [www.nationalpolkafestival.com/](http://www.nationalpolkafestival.com/)
- Ennis Bluebonnet Trails Festival – The event is the month of April. No lanes closures on the various Farm-to-Market roadways will be allowed without

County: DISTRICTWIDE

Highway: VA

Engineer approval. The roadways vary each year. Please see the event website for a current map and list of roadways. <https://www.visitennis.org/bluebonnet.htm>

- Texas Motorplex - There are several major events held including the Spring, Summer, and Fall NHRA Nationals. These events affect US-287 (between Ennis and Waxahachie). No lane closures will be allowed without Engineer approval. Please visit the Texas Motorplex website for current schedule for specific dates and times. [www.texasmotorplex.com](http://www.texasmotorplex.com)
- Scarborough Renaissance Festival – Waxahachie, Texas – The event is every weekend (Saturday and Sunday) during the months of April and May. The event affects IH-35E northbound and southbound between mile markers 397 – 402 and FM-66. No lane closures will be allowed without Engineer approval. Additional information may be found on the events website. [www.srfestival.com](http://www.srfestival.com)
- The University of Texas vs. University of Oklahoma football game (no lane closures beginning 4 hr. prior to the event and ending 3 hr. following event completion).

Roadway closures during the following key dates and/or special events are prohibited in Dallas County.

Event Restrictions – No Lane Closures that restricts or interferes with traffic will be allowed for the regional events set forth below. This affects IH30, IH30 HOV, IH35E, IH35E HOV, IH45, IH345, SH352, and SS366. TxDOT has the right to lengthen, shorten, or otherwise modify these restrictions as actual traffic conditions may warrant. TxDOT also has the right to modify the list of major events as they are added, renamed, rescheduled, or as warranted.

- State Fair of Texas (no lane closures after 6 A.M. on Fridays through 9 P.M. on Sundays; no full closures for any direction of any facility from opening day through the closing day).
- The University of Texas vs. University of Oklahoma football game (no lane closures beginning 4 hr. prior to the event and ending 3 hr. following event completion).
- The First Responder Bowl (no lane closures beginning 3 hr. prior to the event and ending 2 hr. following the event completion).
- Dallas Mavericks Home Games (no lane closure beginning 2 hr. prior to the event and ending ½ hr. following event commencement with no full lane closures considered until 2 hr. following event completion).
- Dallas Stars Home Games (no lane closure beginning 2 hr. prior to the event and ending ½ hr. following event commencement with no full lane closures considered until 2 hr. following event completion).
- Texas Rangers Home Games (no lane closure beginning 2 hr. prior to the event and ending ½ hr. following event commencement with no full lane closures considered until 2 hr. following event completion).
- Dallas Cowboys Home Games (no lane closure beginning 2 hr. prior to the event and ending ½ hr. following event commencement with no full lane closures considered until 2 hr. following event completion).
- Major Events at the American Airline Center, Globe Life Park in Arlington, AT&T Stadium with expected attendance exceeding 15,000 (no lane closures beginning

County: DISTRICTWIDE

Highway: VA

2 hr. prior to event and ending ½ hr. following event commencement with no full closures considered until 2 hr. following event completion).

- Major Downtown Dallas Events (restrictions will be considered on a case-by-case basis). This category could include, but is not limited to, parades for sports championships, major political events, major Art District Events, and large athletic events such as marathons.

**Item 8:**

This project charges by Calendar Days in accordance with Article 8.3.1.5 and the work orders will be based on a Standard Workweek in accordance with Article 8.3.1.4. Multiple work orders may be issued concurrently. Provide suitable machinery, equipment, and construction forces for the proper prosecution of the work. The construction forces shall be able to complete 2 work orders simultaneously. In addition, if extended periods of time are anticipated between issuance of work orders to the Contractor, time charges may be suspended by the Engineer.

The response time specified in this contract is an essential element. Liquidated damages will be assessed when the Contractor fails to begin work within the specified response time for any work order. The dollar amount specified in this contract will be deducted from any money due or to become due for any work order and will continue to be deducted for each day until work begins. This amount will be assessed not as a penalty, but as liquidated damages.

A 90 day construction delay is included in this contract through Special Provision 008-005. This delay is included for material acquisition for the initial work order on the project.

**Item 162:**

Install block sod as directed by the Engineer.

**Item 168:**

Water once a day where sod is installed. Include cost for this work in the unit bid price for this item.

**Item 361:**

The removal of any raised medians or islands dowelled on top of concrete repair sections will be considered subsidiary to Item 361.

**Item 416:**

Drilled shafts shall be drilled and poured on the same day unless directed by the engineer.

County: DISTRICTWIDE

Highway: VA

Provide a formed smooth finish for all portions of drill shafts extending above proposed ground. Include cost for this work in the unit bid price for this item.

Traffic signal pole and/or illumination pole foundations will be paid for once regardless of extra work caused by obstructions.

Concrete removal required for installation of drilled shafts will be subsidiary to Item 416.

**Item 421:**

Furnish mix designs to the Engineer in a format compatible to the latest version of the Department's Construction Management System (SiteManager). Mix Design templates will be provided by the Engineer.

Provide sulfate resistant concrete for all drilled shafts.

Provide all freshly mixed concrete testing equipment as required by subsection 3.3, except as noted here. Curing facilities, maturity meters, and strength-testing equipment will not be required. Air content testing is waived for this project. All testing equipment shall be clean and in like-new condition. Test molds shall be 4" diameter x 8" tall.

**Items 440:**

Fiber Reinforced Concrete (FRC) can be used as a substitute for Non-Structural Class Reinforced Concrete in Mow-Strip and Rip Rap Items as approved. FRC may also be used for other Non-Structural Class Reinforced Concrete Items as approved.

**Item 449:**

Use Thomas & Betts Kopr-Shield, MG Chemicals #846, MG Chemicals #8463, NYOGEL #756G, Pro-Shield #7308, Cho-Lube #4220, or other approved electrically conducting lubricant compound.

**Item 502:**

The Contractor Force Account "Safety Contingency" that has been established for this project is intended to be utilized for work zone enhancements, to improve the effectiveness of the Traffic Control Plan, that could not be foreseen in the project planning and design stage. These enhancements will be mutually agreed upon by the Engineer and the Contractor's Responsible Person based on weekly or more frequent traffic management reviews on the project. The Engineer may choose to use existing bid items if it does not slow the implementation of enhancement.

Access will be provided to all business and residences at all times. Where turning radii are limited during phased construction at intersections, provide all weather surfaces such as RAP or base in turning movements to accommodate and to protect the traffic from edge drop-offs. Materials, labor, maintenance and removal for these temporary accesses and radii will not be paid for directly but will be considered subsidiary to the various bid items.

County: DISTRICTWIDE

Highway: VA

Place barricades and signs in locations that do not obstruct the sight distance of drivers entering the highway from driveways or side streets.

Do not commence work on the road before sunrise. Do not operate or park any equipment/machinery closer than 30 feet from the traveled roadway after sunset unless authorized by the engineer.

Payment for Item 502-7001 will be prorated on a daily basis based on the number of days worked during the month with traffic control in place. This item will not be paid when working days have been suspended between work orders. In addition, when work is not being performed and/or traffic control is not in place, this item will not be paid.

When moving unlicensed equipment on or across any pavement or public highways, protect the pavement from all damage using an acceptable method.

Limit lane closures along to the hours between 9:00 am and 3:30 pm. Work in other areas of the project is not restricted to this time frame.

**Item 505:**

The total number of truck mounted attenuators (TMA) required when utilizing the traffic control standards are shown in the tables below.

TCP 2 Series	Scenario	Required TMA/TA	
(2-1)-18 / (2-2)-18 / (2-4)-18 / (2-5)-18 / (2-6)-18	All	1	
(2-3)-18	A   B	1	2

WZ (BTS) Series	Scenario	Required TMA
(BTS-1)-13	Near Side Lane Closure	1

Shadow vehicles equipped for truck mounted attenuators (TMA) for stationary operations will be paid for by the day and must be available for use at any time as determined by the Engineer.

Therefore, 1 total shadow vehicle with TMA will be required for this type of work. The contractor will be responsible for determining if one or more of these operations will be ongoing at the same time to determine the total number of TMAs needed for the project for those times per plan requirements. Additional TMAs used that are not specified in the plans in which the contractor expects compensation will require prior approval from the Engineer.

**Item 506:**

Install Biodegradable Erosion Control Logs as directed by the Engineer.

County: DISTRICTWIDE

Highway: VA

**Item 529:**

Provide grooved joints at 10-foot intervals and  $\frac{3}{4}$  inch expansion joint material for doweled curb at the same locations as on the existing pavement.

For Curb and Gutter sections, provide grooved joints at 10-foot intervals and  $\frac{3}{4}$  inch expansion joint material at a maximum of 50-foot centers and at all radius points and inlets.

Curb and Gutter transitions will be paid for by the foot at the unit price for the corresponding curb or curb and gutter section.

Saw joints at the same location as on the existing pavement.

**Item 531:**

Joint Sealing is subsidiary to Item 531.

**Item 610:**

The luminaire arm and fixture shall be delivered to the District Signal Shop if they are not needed on the work order plan.

When luminaire poles are used for signal or pedestrian heads at an intersection, provide 12 circuit Buchanan Type 112SN, Kulka Type 985-GP-10 CU, or equal terminal strip in the luminaire pole access compartment. The conductors for the line and load side of the terminal strip shall be identified with a plastic label with two straps per tag. The load side shall have each signal head and ped head identified on the tag.

**Item 618:**

Place conduit under railroad tracks to maintain a minimum of 42" below the bottom of the ties.

The location of conduits and ground boxes are diagrammatic only and may be shifted to accommodate field conditions as directed.

Secure permission and approval from the proper authority prior to cutting into or removing any sidewalks or curbs for installation of this Item.

When holes are drilled through concrete structures, use a coring device. Do not use masonry or concrete drills.

Structurally mount junction boxes as shown on the plans. When used for traffic signal installations, use boxes 12"x12"x8", or as approved.

Use conduit hangers for 3 inch and larger conduit when hanging conduit from structures.

County: DISTRICTWIDE

Highway: VA

Place conduit under existing pavement by an approved boring method. Do not place boring pits closer than 2 feet from the edge of the pavement unless otherwise directed. Do not use water jetting. When conduits are bored, do not exceed 18 inches in the vertical and horizontal tolerances as measured from the intended target point.

Do not use a pneumatically driven device for punching holes beneath the pavement (commonly known as a "missile").

Furnish and install a flat, high tensile strength polyester fiber pull tape in conduit runs in excess of 50 feet or for future use and protected with standard weather-tight conduit caps, as approved. Acceptable products include Garvin # PT-1250-3K, ComStar PUL 1250P3K, Ideal Part No. 31-315 or equal as approved by the Engineer. This work will not be paid for directly, but is subsidiary to this Item.

Use a colored cleaner-primer on all PVC to PVC joints before application of PVC cement.

Seal all conduit ends with a permanently soft, non-toxic duct seal. Use a duct seal that does not adversely affect other plastic materials or corrode metals.

If existing conduit is proposed for reuse in this project, conduit prep will be paid for under this item.

When using existing conduit, ensure that all conduits have bushings and are cleaned of mud and debris. Restrap conduit that is being relocated to new timber poles as if it were a new installation. This work will not be paid for directly, but is subsidiary to this Item.

Where sidewalk is removed to install trenched conduit, replace sidewalk to match existing material. This work will be subsidiary to Item 618 except where shown otherwise in the plans.

For projects in the City of Denton, where two conduits are shown to be installed between ground boxes, these conduits shall be parallel and bored separately. Install cables and conductors of 120 V equipment through one conduit and low voltage equipment in the other conduit. Avoid crossing high and low voltage cables in ground boxes where possible.

2" Schedule 80 PVC will be used at the power pole to supply electricity to underground services.

**Item 620:**

The equipment grounding conductor shall be identified by a continuous green colored jacket insulation or bare wire. Grounded conductors (Neutral) shall be identified by a continuous white colored jacket. Ungrounded conductors (Hot) in a 120/240v system shall be identified by each pole or leg. For 240-volt branch circuit fed from 120/240

County: DISTRICTWIDE

Highway: VA

source, ensure one leg is identified by a continuous black colored jacket and the other leg by a continuous red colored jacket.

**Item 624:**

Slack conductors required by Standard Sheet ED(3)-14 will be subsidiary to Item 624.

Concrete removal required for installation of ground boxes will be subsidiary to Item 624.

**Item 627:**

Use the timber pole heights, as shown on the plans and in the material summary, for bidding purposes only. Coordinate pole locations, and make field measurements before construction to ensure a vertical clearance of 17 to 19 feet from the highest point on the roadway surface to the span. Except for supplemental nearside signal heads, all signal heads must be installed at least 40' from the stop line. If field adjustments result in the nearest signal head being more than 180' from the stop line, install a supplemental nearside signal head as directed by the engineer. Determine the field measurements and elevations from the actual field location of the poles, considering all above and below ground utilities and existing roadway elevations.

Weather heads, grounding equipment, 8-foot luminaire arms for mounting on timber poles, and concrete backfill (when required) shall not be paid for directly, but will be considered subsidiary to this Item.

**Item 628:**

Contact the appropriate utility company during the first three weeks of the project lead-time period to allow adequate time for any necessary utility adjustments, transformer installation, etc.

Contractor shall submit an online request at ONCOR.com by following the steps below:  
 Select Construction and Development tab at top of screen.  
 Scroll down to Request New Service under New Construction Portals.  
 Select the Start Request icon under the Commercial and Industrial project type.  
 Select the One Single Building Facility tab and fill in all required information, including TxDOT, the project name, and CSJ in the Additional Comments box.  
 Submit the request. An ONCOR representative will respond to the request within a few days with a Work Order Number and the ONCOR designer contact information.

Granite concrete service pole embedment depth shall be 10' and shall be a minimum of 25' above grade.

Backfill Granite Concrete service poles with a Class A concrete in accordance with Item 421, "Hydraulic Cement Concrete", except consider the concrete subsidiary to Item 628 for payment purposes.

County: DISTRICTWIDE

Highway: VA

The Meter Base or Transocket shall be mounted facing the roadway and the service enclosure shall be mounted on the opposite side of the service pole or pedestal.

Label the service enclosures indicating service address as well as all required information as shown on the Electrical Detail (ED) standard sheets. Labeling shall be silk screening or other acceptable method. This work will not be paid for directly, but is subsidiary to this Item.

A Licensed Master Electrician shall oversee the installation of all electrical services.

Bill the electrical service power usage to the Texas Department of Transportation, unless otherwise directed, or noted on the Work Order plans.

On the outside lower front of each electrical service meter base cover, install a 12-gauge minimum thickness stainless steel, aluminum, or brass placard. The placard shall be engraved or stamped with the numeric portion of the street address and permanently affixed to the cover with exterior rated adhesive so as not to interfere with the operation of the latch. This work will not be paid for directly, but is subsidiary to this Item.

For work orders in the City of Dallas for non-controlled access locations the Contractor will be responsible for the following:

1. Prior to application for electrical service connection, the Contractor shall apply for an electrical service permit at 320 E. Jefferson Street in Dallas and have the new electrical service inspected and "green-tagged" at their expense. The Contractor shall apply for inspection of the installed electrical service infrastructure by the utility company, and shall coordinate the installation of underground cable by the utility company. The Contractor shall notify City of Dallas Traffic Signal staff with regular updates about information relevant to setting up electric service accounts for the project.
2. Upon receipt of "green tag" and after underground cable is installed by the utility company for each location, the Contractor shall provide a copy of the "green tag" to Mr. Alfred Lemon and Mr. Favian Giraldo at the City of Dallas Signal Shop. The City shall submit the request for new electric service to the utility provider upon receipt of a copy of the "green tag". Electrical service accounts for each new electrical service shall be established by and billed to the City of Dallas.

**Item 644:**

Prior to taking elevations to determine lengths for fabrication of sign posts, obtain verification of all proposed locations.

All sign mounts shall have a clamp base system for all small roadside sign assemblies.

A 3 inch strip of red reflective sheeting shall be placed on all Do Not Enter sign assemblies. This sheeting shall be placed directly below the Do Not Enter sign for the entire length of the sign post facing wrong way traffic. This work will be considered subsidiary to Item 644.



County: DISTRICTWIDE

Highway: VA

**Item 656:**

Before placing the concrete for the controller foundation, coordinate with the appropriate City as needed to ensure that the anchor bolt spacing will match the anchor bolts and cabinet supplied by the city.

Form a 3/4-inch chamfer on the top edge of each pedestal pole foundation.

Probe for utilities and underground structures prior to drilling foundations. Foundations shall be paid for once regardless of extra work caused by obstructions.

**Item 662 and 672:**

Black adhesive will be used on asphalt pavements and white adhesive will be used on concrete pavements.

**Item 677:**

A water blasting method approved by the Engineer will be the only method allowed for the removal of permanent and temporary pavement markings except on a sealcoat surface. A 2 foot wide sealcoat will be required on sealcoat surfaces to eliminate permanent and temporary pavement markings.

**Item 680:**

Requirements for this Item include the following work, all of which are subsidiary to this Item:

1. Notify the Traffic Projects Office at [DAL\\_TPO@txdot.gov](mailto:DAL_TPO@txdot.gov) one week before beginning any work involving traffic signals. Supplement email correspondence with the District Signal Maintenance Office at (214)320-6682 and Construction Office at (214)319-6406.
2. Provide submittal literature for all traffic signal equipment before installation.
3. Furnish and install a new controller (eight phase NEMA TS 2 Type 1) and cabinet (NEMA TS 2 Size 6, 16 position load bay), meeting the requirements of Departmental Materials Specifications DMS-11170. Provide detector panel toggle switches that additionally permit the user to disconnect the detector. Provide new MMU with Ethernet port. For a pole-mount controller, provide three mounting brackets and install a 5' x 5' x 4" Class A concrete pad under the cabinet in accordance with Items 420 and 421.
4. If the signal controller and cabinet are to be supplied by the City specified on a Work Order, pick up and install the City supplied equipment as shown on the Work Order. For Work Orders which specify a City supplied controller and cabinet, the Contractor furnished controller and cabinet shall be delivered to the TxDOT Dallas District Office.
5. Deliver the cabinet, controller, and accessories (with all cabinet components completely connected and securely strapped down) to the District Signal Shop, 4777

County: DISTRICTWIDE

Highway: VA

E Hwy 80, Mesquite, for testing. Notify the District Signal Shop two working days before delivery at (214)320-6682.

6. If the Work Order requires conventional loop detection, provide detector cards that have a Liquid Crystal Display (LCD) of all operational and diagnostic information. The LCD shall show all major parameters of the loop operation including loop frequency, loop inductance, inductance change, and loop faults. Loop faults include open circuit, short circuit, and inductance change. Provide a user's manual with full operating instructions and the contact name, address, and telephone number for the representative, manufacturer, or distributor for warranty repair. Submit a copy of a test report certified by an independent laboratory that the detector unit model submitted meets NEMA TS1 requirements.
7. Install the controller cabinet in an orientation as directed.
8. Connect all field wiring to the controller assembly. The City or District will assist in determining how the detection cables are to be connected, and will also program the controller for operation, hook up the malfunction management unit (MMU) or conflict monitor, detector units, and other equipment, and turn on the controller. Pick up the signal cabinet from the City or District Signal Shop. Have a qualified technician and a representative from the controller supplier on the project site to place the traffic signals in operation.
9. Furnish and install all Contractor supplied sign panels for mounting on signal poles, mast arms, and span wires. Fabricate the sign panels in accordance with Item 636, and mount with Astro-Sign Brac, Signfix aluminum channel, or equal as approved by the Engineer. Submit five (5) sets of shop drawings for street name signs. Pick up and install all City supplied sign panels or ILSN signs for mounting on signal poles, mast arms, and span wires. Furnish all mounting hardware for all signs except ILSN signs
10. Provide 250W Equivalent LED Fixtures with 120 – 277 volt electronic LED drivers as shown on the Material Producers List.
11. Remove the existing stop sign panels or assemblies after the traffic signals are in operation.
12. Install the emergency vehicle preemption equipment supplied by the City as shown on each individual work order.
13. Use qualified personnel to respond to and diagnose all trouble calls during the thirty-day test period. Repair any malfunction to Contractor-supplied signal equipment. Provide to the Engineer a local telephone number, not subject to frequent changes and available on a 24-hour basis, for reporting trouble calls. Response time to reported calls must be less than 2 hours. Make appropriate repairs within 24 hours. Place a logbook in the controller cabinet and keep a record of each trouble call reported. Notify the Engineer of each trouble call. Do not clear the error log in the conflict monitor or MMU during the thirty-day test period without approval.
14. Prevent any damage to property owner's poles, fences, shrubs, mailboxes, etc. Protect all underground and overhead utilities and repair any damage. Provide access to all driveways during construction.
15. Integrate the proposed traffic signal(s) into the existing closed loop system as shown on the plans. CENTRACS closed loop software, which utilizes Econolite Cobalt controllers, is currently in use in the Dallas District. Provide controllers on this project that fully communicate with the existing closed loop system.

County: DISTRICTWIDE

Highway: VA

16. The concrete foundation for the controller as shown on standard TS-CF is diagrammatic and the dimensions will be adjusted in the field to fit existing conditions.
17. Salvage the existing traffic signals as shown on the work order plans. Salvage poles, cabinets, service poles, and any other equipment as directed. This equipment remains the property of the Texas Department of Transportation or the City specified in the Work Order. The material listed above shall be stockpiled at the TxDOT District Signal Shop, 4777 E Hwy 80, Building N, Mesquite, Tx 75150 or location designated in the work order as directed. Contact the District Signal Shop at 214-320-6682 48 hours in advance of delivery of TxDOT material. All other material removed in this project will become the property of the Contractor. Dispose of material off the right of way in accordance with federal, state, and local regulations. Maintain the operation of the existing traffic signal until directed to remove it.

**Item 682:**

Install signal head attachments so that the wiring to each signal head passes from the mast arm through the attachment hardware to the signal head. Do not leave cable or wiring exposed.

Provide signal head attachments that allow for adjustment about the horizontal and vertical axis.

Unless otherwise shown on work order plans, provide aluminum pedestrian and vehicle signal heads in the following color: Federal Yellow #13538 of Federal Standard 595. Provide non-painted aluminum tubing. Provide back plates, louvers, and the inside of visors with a flat black finish. Provide aluminum vented retroreflective back plates for all traffic signal heads.

Turn down signal heads or cover with burlap or other material, as approved, until traffic signal is placed in operation.

Mount signal heads level and plumb and aim as directed.

Provide louvers that have 5 vanes and a flat black finish on the inside surfaces. Securely fasten a hardware cloth screen with 5/8 inch or smaller mesh size to the front face of each louver to prevent entry by birds.

**Item 684:**

Provide 18 AWG Type C signal cables for loop detector lead-ins.

Provide stranded 14 AWG Type A signal cables for LED signal heads and stranded 12 AWG Type C cables for APS units.

Provide a separate multi-conductor signal cable (14 AWG) inside pedestal poles and signal poles from the terminal strip to each signal head as shown on the plans.

County: DISTRICTWIDE

Highway: VA

Identify each cable as shown on the plans (cable 1, etc.) with permanent marking labels (Panduit Type PLM standard single marker tie, Thomas&Betts Type 548M, or equal) at each ground box, pole base, and controller.

**Item 685:**

For non-timed installations, such as "Signal Ahead" flasher, a solid-state time clock will not be required in the flasher controller assembly.

**Item 686:**

Provide 12 circuit Buchanan Type 112SN, Kulka Type 985-GP-12 CU, or equal terminal strips in the signal pole access compartment. Provide additional terminal strips of 8 circuits each when more than 12 circuits are required. The conductors for the line and load side of the terminal strip shall be identified with a plastic label with two straps per tag. The load side shall have each signal head and ped head identified on the tag.

Mark pole shafts and mast arms with the identification numbers from the plans to facilitate field-assembly. Identify pole shafts and mast arms by intersection for projects with multiple intersections.

Provide nuts on top and bottom (double nuts) of the base plate as shown on the plans.

Set anchor bolts for mast arm signal poles and strain poles so that two are in tension and two are in compression. Obtain approval of anchor bolt placement before placing concrete.

Provide vertical clearance of 17 to 19 feet from the roadway to the lowest point of the signal head or mast arm. Except for supplemental nearside signal heads, all signal heads must be installed at least 40' from the stop line. If field adjustments result in the nearest signal head being more than 180' from the stop line, install a supplemental nearside signal head as directed by the engineer. Determine the field measurements and elevations from the actual field location of the poles, considering all above and below ground utilities and existing roadway elevations.

Provide vibration dampers for mast arms 28 feet to 48 feet in length. Install as shown on MA-DPD.

For mast arm poles designated with an ILSN bid code, the ILSN arm, clamps, bolts, and washers will be considered part of the complete pole assembly. The ILSN signs and mounting hardware will be furnished by the applicable City.

The bid price for this item is for a standard galvanized signal pole. If a City requests powder coating on signal poles, The City will pay the Contractor directly for powder coating and all associated costs. The Contractor shall coordinate with the City to collect this payment. Contact the City for further information. Powder coating must meet the requirements of the City.

County: DISTRICTWIDE

Highway: VA

For existing signal poles, replacement of existing conductors is not required inside the poles. Plug any unused openings in existing mast arms and poles with an approved material.

Provide 3 pipe plugs for wiring access on strain poles.

Provide a three piece bracket assembly on strain poles or drill the pole and use thimble eye bolts to attach the strain vise for the span wire.

**Item 687:**

The bid price for this item is for a standard galvanized pedestal pole. If a City requests powder coating on pedestal poles, The City of will pay the Contractor directly for powder coating and all associated costs. The Contractor shall coordinate with the City to collect this payment. Contact the City for further information. Powder coating must meet the requirements of the City.

Provide 12 circuit Buchanan Type 112SN, Kulka Type 985-GP-10 CU, or equal terminal strip in the pedestal pole base. The conductors for the line and load side of the terminal strip shall be identified with a plastic label with two straps per tag. The load side shall have each signal head and ped head identified on the tag.

**Item 688:**

Maintain a minimum 12 inch separation between loop lead-in sawcuts and loop sawcuts, and a minimum 6 inch separation between loop lead-in sawcuts and other loop lead-in sawcuts.

Use loop wire for concrete pavement and loop duct for asphalt pavements.

Install loop detectors only during off-peak traffic periods.

Verify the locations of the APS units or push button assemblies and the direction of the arrows on the signs prior to installation.

Contractor shall provide a digital copy of the APS messages to TxDOT for all new APS Units on the project.

APS Units shall operate with hardwired connections for the communications path between the APS Units and the APS controller.

Assist the Engineer in determining the loop inductance of each loop detector installation. In the presence of the engineer, conduct field testing to determine the total inductance of the loop detector and the percentage shift in loop inductance for various size vehicles.

County: DISTRICTWIDE

Highway: VA

**Item 6006:**

Install the Video Processor System so that it interfaces with the traffic controller unit (CU) via the detector rack. If the manufacturer does not have a product to interface via the detector rack, interface via SDLC.

For each work order containing this bid item provide spare VIVDS equipment consisting of one additional camera, paid for by bid item, and one additional VIVDS detector rack card, subsidiary to the Video Processor System bid item. Deliver spare equipment to District Signal Shop at 4777 E Hwy 80, Mesquite, Tx, 75150.

If the camera locations shown in the plans do not allow for proper sight of the proposed detection zones, relocate the cameras as needed and as directed. This labor and material cost will not be paid separately, but is subsidiary to these items.

**Item 6007:**

If the BBU is side-mounted, the BBU will be installed with the controller on the concrete pad paid for under Item 680. If a larger pad is needed to accommodate the BBU, the additional labor and material will be subsidiary to this item.

If the BBU will be furnished by the City specified on the Work Order, pick up and install the City supplied BBU as shown on the Work Order. For such cases, the Contractor furnished BBU shall be delivered to the District Signal Shop.

**Item 6008:**

For the first Work Order that specifies Stop Bar Presence Radar and/or Set Back Advance Radar, provide 8 hours of operational and maintenance training for all brands of radar provided on this project to designated personnel. Provide this training for a maximum of 12 people, at a time and location approved by the Engineer. Provide training which includes, but not limited to "hands-on" operation for each type of equipment; explanation of all system commands, function, and usage; required preventative maintenance procedure; and system "trouble-shooting" or problem identification. Submit an outline of the proposed training material for approval at least 60 days before the training begins.

Relocation of sensors and all additional items such as poles, conduit, cable, etc. required to achieve the detection specified in the plans will not be paid for separately, but will be considered subsidiary to this item.

**Item 6013:**

If existing ground boxes are proposed for reuse in this project, ground box prep will be paid for under this item.

County: DISTRICTWIDE

Highway: VA

The list of material below is for the Contractor's information only.  
It is the responsibility of the Contractor to verify  
all items and quantities listed below.

LIST OF MATERIAL  
FURNISHED BY CITY (SPECIFIED IN EACH WORK ORDER)

EQUIPMENT FURNISHED BY CITY		
DESCRIPTION	UNIT	QUANTITY
CONTROLLER, CABINET AND ACCESSORIES	EA	1
OPTICOM EQUIPMENT	LS	1
BBU	EA	1
STREET NAME SIGNS	EA	*

\*AS SHOWN IN WORK ORDER PLAN

LIST OF MATERIAL  
SUBSIDIARY TO ITEM 680 (FLASHING BEACON)

ITEM 680-6001 FLASHING BEACON BREAKDOWN PER INTERSECTION (SPECIFIED IN EACH WORK ORDER)		
DESCRIPTION	UNIT	QUANTITY
FLASHING BEACON CONTROLLER/CABINET	EA	1
SIGNS (REGULATORY AND STREET NAME)	EA	*
5'X5'X4" CONCRETE PAD FOR POLE MOUNTED CABINET (CLASS A)	CY	0.31
250W EQUIVALENT LED LUMINAIRE	EA	*

\*AS SHOWN IN WORK ORDER PLAN

County: DISTRICTWIDE

Highway: VA

LIST OF MATERIAL/LABOR  
SUBSIDIARY TO ITEM 680 (ISOLATED)

ITEM 680-6002 BREAKDOWN PER INTERSECTION (SPECIFIED IN EACH WORK ORDER)		
DESCRIPTION	UNIT	QUANTITY
TRAFFIC CONTROLLER, CABINET & ACCESSORIES	EA	1
5/8" X 8 LF COPPERCLAD GROUND ROD W/CLAMP	EA	1
INSTALL EQUIPMENT SUPPLIED BY CITY	LS	1
SIGNS (REGULATORY AND STREET NAME)	EA	*
REMOVE SIGN PANELS	EA	*
8'X9'X6" TRAFFIC SIGNAL CONTROLLER FOUNDATION (BASE MOUNT) (CLASS B)	CY	1.3
TRAFFIC SIGNAL CONTROLLER BASE	EA	1
5'X5'X4" CONCRETE PAD FOR POLE MOUNT CABINET (CLASS A)	CY	0.31
2 CHANNEL DETECTOR CARDS	EA	*
DETECTOR CARD RACK	EA	*
250W EQUIVALENT LED LUMINAIRE	EA	*
WIRE THE CABINET AND ACCESSORIES	LS	1

\*AS SHOWN IN WORK ORDER PLAN



# Estimate & Quantity Sheet

CONTROLLING PROJECT ID 0918-00-392

DISTRICT Dallas  
HIGHWAY Various

COUNTY Dallas

CONTROL SECTION JOB				0918-00-392		TOTAL EST.	TOTAL FINAL
PROJECT ID				A00189293			
COUNTY				Dallas			
HIGHWAY				Various			
ALT	BID CODE	DESCRIPTION	UNIT	EST.	FINAL		
	104-7008	REMOV CONC (MEDIANS)	SY	10.000		10.000	
	104-7011	REMOV CONC (DRIVEWAYS)	SY	10.000		10.000	
	104-7013	REMOV CONC (SIDEWALK, RAMP OR SUP)	SY	10.000		10.000	
	104-7018	REMOV CONC (CURB OR CURB & GUTTER)	LF	15.000		15.000	
	104-7046	REMOV CONC (MISC)	SY	15.000		15.000	
	162-7002	BLOCK SODDING	SY	100.000		100.000	
	168-7001	VEGETATIVE WATERING	TGL	10.000		10.000	
	361-7044	FULL-DEPTH REPAIR CRCP (VAR DEPTH)	CY	2.000		2.000	
	416-7040	DRILL SHAFT (RDWY ILL POLE) (30 IN)	LF	25.000		25.000	
	416-7043	DRILL SHAFT (TRF SIG POLE) (30 IN)	LF	50.000		50.000	
	416-7044	DRILL SHAFT (TRF SIG POLE) (36 IN)	LF	150.000		150.000	
	416-7046	DRILL SHAFT (TRF SIG POLE) (48 IN)	LF	100.000		100.000	
	432-7001	RIPRAP (CONC)(4 IN)	CY	2.000		2.000	
	500-7001	MOBILIZATION	LS	1.000		1.000	
	502-7001	BARRICADES, SIGNS AND TRAFFIC HANDLING	MO	30.000		30.000	
	503-7001	PORTABLE CHANGEABLE MESSAGE SIGN	DAY	50.000		50.000	
	505-7001	TMA (STATIONARY)	DAY	10.000		10.000	
	506-7045	BIODEG EROSN CONT LOGS (IN STL) (18")	LF	250.000		250.000	
	506-7046	BIODEG EROSN CONT LOGS (REMOVE)	LF	250.000		250.000	
	529-7001	CONC CURB (TY I)	LF	50.000		50.000	
	529-7002	CONC CURB (TY II)	LF	50.000		50.000	
	529-7008	CONC CURB & GUTTER (TY I)	LF	50.000		50.000	
	529-7009	CONC CURB & GUTTER (TY II)	LF	50.000		50.000	
	531-7001	CONC SIDEWALKS (4")	SY	15.000		15.000	
	531-7003	CONC SIDEWALKS (6")	SY	50.000		50.000	
	531-7005	CURB RAMPS (TY 1)	EA	2.000		2.000	
	531-7006	CURB RAMPS (TY 2)	EA	2.000		2.000	
	531-7007	CURB RAMPS (TY 3)	EA	2.000		2.000	
	531-7008	CURB RAMPS (TY 5)	EA	2.000		2.000	
	531-7009	CURB RAMPS (TY 6)	EA	2.000		2.000	
	531-7010	CURB RAMPS (TY 7)	EA	2.000		2.000	
	531-7011	CURB RAMPS (TY 10)	EA	2.000		2.000	
	531-7012	CURB RAMPS (TY 20)	EA	2.000		2.000	
	531-7013	CURB RAMPS (TY 21)	EA	2.000		2.000	
	531-7014	CURB RAMPS (TY 22)	EA	2.000		2.000	
	536-7001	CONC MEDIAN	LF	10.000		10.000	
	536-7004	CONC DIRECTIONAL ISLAND	SY	30.000		30.000	



DISTRICT	COUNTY	CCSJ	SHEET
Dallas	Dallas	0918-00-392	4



CONTROLLING PROJECT ID 0918-00-392

DISTRICT Dallas  
HIGHWAY Various

COUNTY Dallas

# Estimate & Quantity Sheet

CONTROL SECTION JOB				0918-00-392		TOTAL EST.	TOTAL FINAL
PROJECT ID				A00189293			
COUNTY				Dallas			
HIGHWAY				Various			
ALT	BID CODE	DESCRIPTION	UNIT	EST.	FINAL		
	610-7009	REMOVE RD IL ASM (TRANS-BASE)	EA	1.000		1.000	
	610-7071	IN RD IL (TY SA) 30T-4-4 (250W EQ) LED	EA	1.000		1.000	
	610-7124	IN RD IL (TY SA) 40T-8 (250W EQ) LED	EA	1.000		1.000	
	610-7196	IN RD IL (TY SA) 50T-8 (400W EQ) LED	EA	1.000		1.000	
	618-7021	CONDT (PVC) (SCH 40) (1")	LF	20.000		20.000	
	618-7022	CONDT (PVC) (SCH 40) (1") (BORE)	LF	20.000		20.000	
	618-7030	CONDT (PVC) (SCH 40) (2")	LF	1,000.000		1,000.000	
	618-7031	CONDT (PVC) (SCH 40) (2") (BORE)	LF	500.000		500.000	
	618-7036	CONDT (PVC) (SCH 40) (3")	LF	1,000.000		1,000.000	
	618-7037	CONDT (PVC) (SCH 40) (3") (BORE)	LF	1,000.000		1,000.000	
	618-7040	CONDT (PVC) (SCH 40) (4")	LF	1,000.000		1,000.000	
	618-7041	CONDT (PVC) (SCH 40) (4") (BORE)	LF	1,000.000		1,000.000	
	618-7054	CONDT (PVC) (SCH 80) (2")	LF	250.000		250.000	
	618-7072	CONDT (RM) (1")	LF	25.000		25.000	
	618-7076	CONDT (RM) (1 1/2")	LF	25.000		25.000	
	618-7078	CONDT (RM) (2")	LF	150.000		150.000	
	618-7079	CONDT (RM) (2") (BORE)	LF	25.000		25.000	
	618-7082	CONDT (RM) (3")	LF	75.000		75.000	
	618-7083	CONDT (RM) (3") (BORE)	LF	25.000		25.000	
	618-7086	CONDT (RM) (4")	LF	100.000		100.000	
	618-7090	CONDUIT (PREPARE)	LF	300.000		300.000	
	620-7004	ELEC CONDR (NO.12) INSULATED	LF	1,500.000		1,500.000	
	620-7007	ELEC CONDR (NO.8) BARE	LF	5,000.000		5,000.000	
	620-7008	ELEC CONDR (NO.8) INSULATED	LF	10,000.000		10,000.000	
	620-7009	ELEC CONDR (NO.6) BARE	LF	2,000.000		2,000.000	
	620-7010	ELEC CONDR (NO.6) INSULATED	LF	2,000.000		2,000.000	
	620-7011	ELEC CONDR (NO.4) BARE	LF	250.000		250.000	
	620-7012	ELEC CONDR (NO.4) INSULATED	LF	250.000		250.000	
	621-7002	TRAY CABLE (3 CONDR) (12 AWG)	LF	750.000		750.000	
	624-7001	GROUND BOX TY A (122311)	EA	1.000		1.000	
	624-7002	GROUND BOX TY A (122311)W/APRON	EA	2.000		2.000	
	624-7005	GROUND BOX TY C (162911)	EA	2.000		2.000	
	624-7006	GROUND BOX TY C (162911)W/APRON	EA	4.000		4.000	
	624-7008	GROUND BOX TY D (162922)W/APRON	EA	4.000		4.000	
	624-7012	GROUND BOX TY BATTERY (162915)W/APRON	EA	1.000		1.000	
	624-7013	REMOVE GROUND BOX	EA	2.000		2.000	
	625-7001	ZINC-COAT STL WIRE STRAND (3/16")	LF	500.000		500.000	



DISTRICT	COUNTY	CCSJ	SHEET
Dallas	Dallas	0918-00-392	4A



# Estimate & Quantity Sheet

CONTROLLING PROJECT ID 0918-00-392

DISTRICT Dallas  
HIGHWAY Various

COUNTY Dallas

CONTROL SECTION JOB				0918-00-392		TOTAL EST.	TOTAL FINAL
PROJECT ID				A00189293			
COUNTY				Dallas			
HIGHWAY				Various			
ALT	BID CODE	DESCRIPTION	UNIT	EST.	FINAL		
	625-7002	ZINC-COAT STL WIRE STRAND (1/4")	LF	500.000		500.000	
	625-7003	ZINC-COAT STL WIRE STRAND (5/16")	LF	500.000		500.000	
	625-7004	ZINC-COAT STL WIRE STRAND (3/8")	LF	500.000		500.000	
	627-7003	TIMBER POLE (CL 2) 40 FT	EA	2.000		2.000	
	627-7004	TIMBER POLE (CL 2) 50 FT	EA	2.000		2.000	
	628-7002	REMOVE ELECTRICAL SERVICES	EA	1.000		1.000	
	628-7188	ELC SRV TY D 120/240 070(NS)SS(E)GC(O)	EA	3.000		3.000	
	628-7189	ELC SRV TY D 120/240 070(NS)SS(E)GC(U)	EA	1.000		1.000	
	628-7190	ELC SRV TY D 120/240 070(NS)SS(E)PS(U)	EA	10.000		10.000	
	628-7191	ELC SRV TY D 120/240 070(NS)SS(E)SP(O)	EA	1.000		1.000	
	636-7001	ALUMINUM SIGNS (TY A)	SF	100.000		100.000	
	636-7004	REPLACE EXISTING ALUMINUM SIGNS(TY A)	SF	50.000		50.000	
	644-7001	IN SM RD SN SUP&AM TY10BWG(1)SA(P)	EA	10.000		10.000	
	644-7004	IN SM RD SN SUP&AM TY10BWG(1)SA(T)	EA	4.000		4.000	
	644-7009	IN SM RD SN SUP&AM TY10BWG(1)SB(P)	EA	2.000		2.000	
	644-7012	IN SM RD SN SUP&AM TY10BWG(1)SB(T)	EA	2.000		2.000	
	644-7025	IN SM RD SN SUP&AM TYS80(1)SA(P)	EA	2.000		2.000	
	644-7028	IN SM RD SN SUP&AM TYS80(1)SA(T)	EA	1.000		1.000	
	644-7040	IN SM RD SN SUP&AM TYS80(1)SB(T)	EA	1.000		1.000	
	644-7048	IN SM RD SN SUP&AM TYS80(2)SA(P)	EA	1.000		1.000	
	644-7065	RELOCATE SM RD SN SUP&AM TY 10BWG	EA	1.000		1.000	
	644-7067	RELOCATE SM RD SN SUP&AM TY S80	EA	1.000		1.000	
	644-7073	REMOVE SM RD SN SUP&AM	EA	4.000		4.000	
	666-7003	REFL PAV MRK TY I (W)4"(DOT)(100MIL)	LF	75.000		75.000	
	666-7009	REFL PAV MRK TY I (W)6"(DOT)(100MIL)	LF	50.000		50.000	
	666-7015	REFL PAV MRK TY I (W)8"(BRK)(100MIL)	LF	200.000		200.000	
	666-7018	REFL PAV MRK TY I (W)8"(DOT)(100MIL)	LF	50.000		50.000	
	666-7024	REFL PAV MRK TY I (W)8"(SLD)(100MIL)	LF	400.000		400.000	
	666-7030	REFL PAV MRK TY I (W)12"(SLD)(100MIL)	LF	400.000		400.000	
	666-7036	REFL PAV MRK TY I (W)24"(SLD)(100MIL)	LF	500.000		500.000	
	666-7042	REFL PAV MRK TY I (W)(ARROW)(100MIL)	EA	8.000		8.000	
	666-7045	REFL PAV MRK TY I(W)(DBL ARROW)(100MIL)	EA	1.000		1.000	
	666-7066	REFL PAV MRK TY I (W)(WORD)(100MIL)	EA	8.000		8.000	
	666-7081	REFL PAV MRK TY I (W)(RR XING)(100MIL)	EA	1.000		1.000	
	666-7087	REF PAV MRK TY I(W)18"(YLD TRI)(100MIL)	EA	8.000		8.000	
	666-7090	REF PAV MRK TY I(W)36"(YLD TRI)(100MIL)	EA	8.000		8.000	
	666-7108	REFL PAV MRK TY I (Y)4"(DOT)(100MIL)	LF	200.000		200.000	



DISTRICT	COUNTY	CCSJ	SHEET
Dallas	Dallas	0918-00-392	4B



# Estimate & Quantity Sheet

CONTROLLING PROJECT ID 0918-00-392

DISTRICT Dallas  
HIGHWAY Various

COUNTY Dallas

CONTROL SECTION JOB				0918-00-392		TOTAL EST.	TOTAL FINAL
PROJECT ID				A00189293			
COUNTY				Dallas			
HIGHWAY				Various			
ALT	BID CODE	DESCRIPTION	UNIT	EST.	FINAL		
	666-7111	REFL PAV MRK TY I (Y)6"(DOT)(100MIL)	LF	50.000		50.000	
	666-7114	REFL PAV MRK TY I (Y)8"(SLD)(100MIL)	LF	200.000		200.000	
	666-7117	REFL PAV MRK TY I (Y)12"(SLD)(100MIL)	LF	300.000		300.000	
	666-7123	REFL PAV MRK TY I (Y)24"(SLD)(100MIL)	LF	300.000		300.000	
	666-7204	RE PM TY II (W) (BIKE RR XING)	EA	1.000		1.000	
	666-7207	RE PM TY II (W) (BIKE DOT)	EA	50.000		50.000	
	666-7346	PAVEMENT SLER 4"	LF	500.000		500.000	
	666-7347	PAVEMENT SLER 6"	LF	1,000.000		1,000.000	
	666-7348	PAVEMENT SLER 8"	LF	750.000		750.000	
	666-7350	PAVEMENT SLER 12"	LF	1,000.000		1,000.000	
	666-7352	PAVEMENT SLER 24"	LF	1,000.000		1,000.000	
	666-7353	PAVEMENT SLER (ARROW)	EA	8.000		8.000	
	666-7354	PAVEMENT SLER (WORD)	EA	8.000		8.000	
	666-7356	PAVEMENT SLER (DBL ARROW)	EA	1.000		1.000	
	666-7364	PAVEMENT SLER (RR XING)	EA	1.000		1.000	
	666-7365	PAVEMENT SLER (YLD TRI)	EA	25.000		25.000	
	666-7368	PAVEMENT SLER (BIKE ARROW)	EA	2.000		2.000	
	666-7369	PAVEMENT SLER (BIKE SYMBOL)	EA	2.000		2.000	
	666-7370	PAVEMENT SLER (BIKE WORD)	EA	2.000		2.000	
	666-7402	REFL PAV MRK TY I (W)4"(BRK)(100MIL)	LF	750.000		750.000	
	666-7405	REFL PAV MRK TY I (W)4"(SLD)(100MIL)	LF	650.000		650.000	
	666-7408	REFL PAV MRK TY I (W)6"(BRK)(100MIL)	LF	100.000		100.000	
	666-7411	REFL PAV MRK TY I (W)6"(SLD)(100MIL)	LF	800.000		800.000	
	666-7414	REFL PAV MRK TY I (Y)4"(BRK)(100MIL)	LF	50.000		50.000	
	666-7417	REFL PAV MRK TY I (Y)4"(SLD)(100MIL)	LF	750.000		750.000	
	666-7420	REFL PAV MRK TY I (Y)6"(BRK)(100MIL)	LF	50.000		50.000	
	666-7423	REFL PAV MRK TY I (Y)6"(SLD)(100MIL)	LF	100.000		100.000	
	668-7084	PREFAB PM TY C (W)(8")(SLD)	LF	50.000		50.000	
	668-7087	PREFAB PM TY C (W)(12")(SLD)	LF	500.000		500.000	
	668-7089	PREFAB PM TY C (W)(24")(SLD)	LF	500.000		500.000	
	668-7091	PREFAB PM TY C (W)(ARROW)	EA	20.000		20.000	
	668-7093	PREFAB PM TY C (W)(DBL ARROW)	EA	2.000		2.000	
	668-7103	PREFAB PM TY C (W)(WORD)	EA	20.000		20.000	
	668-7108	PREFAB PM TY C (W)(RR XING)	EA	2.000		2.000	
	668-7110	PREFAB PM TY C (W)(18")(YLD TRI)	EA	50.000		50.000	
	668-7111	PREFAB PM TY C (W)(36")(YLD TRI)	EA	100.000		100.000	
	668-7113	PREFAB PM TY C (W)(BIKE ARROW)	EA	4.000		4.000	



DISTRICT	COUNTY	CCSJ	SHEET
Dallas	Dallas	0918-00-392	4C





CONTROLLING PROJECT ID 0918-00-392

DISTRICT Dallas  
HIGHWAY Various

COUNTY Dallas

# Estimate & Quantity Sheet

CONTROL SECTION JOB				0918-00-392		TOTAL EST.	TOTAL FINAL
PROJECT ID				A00189293			
COUNTY				Dallas			
HIGHWAY				Various			
ALT	BID CODE	DESCRIPTION	UNIT	EST.	FINAL		
	668-7114	PREFAB PM TY C (W)(BIKE RR XING)	EA	1.000		1.000	
	668-7115	PREFAB PM TY C (W)(BIKE SYMBOL)	EA	4.000		4.000	
	668-7116	PREFAB PM TY C (W)(BIKE WORD)	EA	8.000		8.000	
	668-7117	PREFAB PM TY C (W)(BIKE DOT)	EA	50.000		50.000	
	672-7001	REFL PAV MRKR TY I-A	EA	100.000		100.000	
	672-7002	REFL PAV MRKR TY I-C	EA	100.000		100.000	
	672-7004	REFL PAV MRKR TY II-A-A	EA	100.000		100.000	
	672-7006	REFL PAV MRKR TY II-C-R	EA	50.000		50.000	
	677-7001	ELIM EXT PM & MRKS (4")	LF	300.000		300.000	
	677-7002	ELIM EXT PM & MRKS (6")	LF	100.000		100.000	
	677-7004	ELIM EXT PM & MRKS (8")	LF	70.000		70.000	
	677-7006	ELIM EXT PM & MRKS (12")	LF	50.000		50.000	
	677-7008	ELIM EXT PM & MRKS (24")	LF	100.000		100.000	
	677-7009	ELIM EXT PM & MRKS (ARROW)	EA	10.000		10.000	
	677-7010	ELIM EXT PM & MRKS (DBL ARROW)	EA	2.000		2.000	
	677-7015	ELIM EXT PM & MRKS (WORD)	EA	10.000		10.000	
	677-7019	ELIM EXT PM & MRKS (RR XING)	EA	2.000		2.000	
	677-7023	ELIM EXT PM & MRKS (18")(YLD TRI)	EA	10.000		10.000	
	677-7024	ELIM EXT PM & MRKS (36")(YLD TRI)	EA	10.000		10.000	
	678-7001	PAV SURF PREP FOR MRK (4")	LF	1,000.000		1,000.000	
	678-7002	PAV SURF PREP FOR MRK (6")	LF	300.000		300.000	
	678-7004	PAV SURF PREP FOR MRK (8")	LF	300.000		300.000	
	678-7006	PAV SURF PREP FOR MRK (12")	LF	500.000		500.000	
	678-7008	PAV SURF PREP FOR MRK (24")	LF	1,500.000		1,500.000	
	678-7009	PAV SURF PREP FOR MRK (ARROW)	EA	35.000		35.000	
	678-7010	PAV SURF PREP FOR MRK (DBL ARROW)	EA	10.000		10.000	
	678-7016	PAV SURF PREP FOR MRK (WORD)	EA	35.000		35.000	
	678-7020	PAV SURF PREP FOR MRK (RR XING)	EA	2.000		2.000	
	678-7022	PAV SURF PREP FOR MRK (18")(YLD TRI)	EA	40.000		40.000	
	678-7023	PAV SURF PREP FOR MRK (36")(YLD TRI)	EA	50.000		50.000	
	678-7026	PAV SURF PREP FOR MRK (BIKE ARROW)	EA	4.000		4.000	
	678-7027	PAV SURF PREP FOR MRK (BIKE RR XING)	EA	1.000		1.000	
	678-7028	PAV SURF PREP FOR MRK (BIKE SYMBOL)	EA	4.000		4.000	
	678-7029	PAV SURF PREP FOR MRK (BIKE WORD)	EA	8.000		8.000	
	678-7030	PAV SURF PREP FOR MRK (BIKE DOT)	EA	50.000		50.000	
	678-7033	PAV SURF PREP FOR MRK (RPM)	EA	100.000		100.000	
	680-7001	INSTALL HWY TRF SIG (FLASH BEACON)	EA	2.000		2.000	



DISTRICT	COUNTY	CCSJ	SHEET
Dallas	Dallas	0918-00-392	4D



CONTROLLING PROJECT ID 0918-00-392

DISTRICT Dallas  
HIGHWAY Various

COUNTY Dallas

# Estimate & Quantity Sheet

CONTROL SECTION JOB				0918-00-392		TOTAL EST.	TOTAL FINAL
PROJECT ID				A00189293			
COUNTY				Dallas			
HIGHWAY				Various			
ALT	BID CODE	DESCRIPTION	UNIT	EST.	FINAL		
	680-7002	INSTALL HWY TRF SIG (ISOLATED)	EA	15.000		15.000	
	680-7004	REMOVING TRAFFIC SIGNALS	EA	2.000		2.000	
	682-7001	VEH SIG SEC (12")LED(GRN)	EA	30.000		30.000	
	682-7002	VEH SIG SEC (12")LED(GRN ARW)	EA	10.000		10.000	
	682-7003	VEH SIG SEC (12")LED(YEL)	EA	30.000		30.000	
	682-7004	VEH SIG SEC (12")LED(YEL ARW)	EA	10.000		10.000	
	682-7005	VEH SIG SEC (12")LED(RED)	EA	30.000		30.000	
	682-7006	VEH SIG SEC (12")LED(RED ARW)	EA	10.000		10.000	
	682-7018	PED SIG SEC (LED)(COUNTDOWN)	EA	15.000		15.000	
	682-7035	LOUVER (12") (ADJUSTABLE)	EA	4.000		4.000	
	682-7042	BACKPLATE W/REF BRDR(3 SEC)(VENT)ALUM	EA	100.000		100.000	
	682-7043	BACKPLATE W/REF BRDR(4 SEC)(VENT)ALUM	EA	25.000		25.000	
	682-7044	BACKPLATE W/REF BRDR(5 SEC)(VENT)ALUM	EA	50.000		50.000	
	684-7031	TRF SIG CBL (TY A)(14 AWG)(5 CONDR)	LF	1,000.000		1,000.000	
	684-7033	TRF SIG CBL (TY A)(14 AWG)(7 CONDR)	LF	1,000.000		1,000.000	
	684-7035	TRF SIG CBL (TY A)(14 AWG)(9 CONDR)	LF	250.000		250.000	
	684-7036	TRF SIG CBL (TY A)(14 AWG)(10 CONDR)	LF	250.000		250.000	
	684-7038	TRF SIG CBL (TY A)(14 AWG)(12 CONDR)	LF	1,000.000		1,000.000	
	684-7042	TRF SIG CBL (TY A)(14 AWG)(16 CONDR)	LF	1,000.000		1,000.000	
	684-7046	TRF SIG CBL (TY A)(14 AWG)(20 CONDR)	LF	1,000.000		1,000.000	
	684-7079	TRF SIG CBL (TY C)(12 AWG)(2 CONDR)	LF	1,500.000		1,500.000	
	684-7082	TRF SIG CBL (TY C)(18 AWG)(2 CONDR)	LF	250.000		250.000	
	685-7001	INSTALL RDS FLASH BEACON ASSEMBLY	EA	1.000		1.000	
	685-7002	RELOCATE RDS FLASH BEACON ASSEMBLY	EA	1.000		1.000	
	685-7003	REMOVE RDS FLASH BEACON ASSEMBLY	EA	1.000		1.000	
	685-7004	INSTL RDS FLSH BCN ASSM (SOLAR PWRD)	EA	1.000		1.000	
	685-7005	RELOCT RDS FLSH BCN AM (SOLAR PWRD)	EA	1.000		1.000	
	686-7006	INS TRF SIG PL AM (S)STR(TY A)	EA	1.000		1.000	
	686-7007	INS TRF SIG PL AM (S)STR(TY B)	EA	1.000		1.000	
	686-7008	INS TRF SIG PL AM (S)STR(TY B)LUM	EA	1.000		1.000	
	686-7015	INS TRF SIG PL AM (S)STR(TY C)(32')	EA	1.000		1.000	
	686-7017	INS TRF SIG PL AM (S)STR(TY C)(36')	EA	1.000		1.000	
	686-7019	INS TRF SIG PL AM (S)STR(TY D)	EA	1.000		1.000	
	686-7020	INS TRF SIG PL AM (S)STR(TY D)LUM	EA	1.000		1.000	
	686-7025	INS TRF SIG PL AM (S)1 ARM(24')	EA	1.000		1.000	
	686-7026	INS TRF SIG PL AM(S)1 ARM(24')ILSN	EA	1.000		1.000	
	686-7027	INS TRF SIG PL AM(S)1 ARM(24')LUM	EA	1.000		1.000	



DISTRICT	COUNTY	CCSJ	SHEET
Dallas	Dallas	0918-00-392	4E



# Estimate & Quantity Sheet

CONTROLLING PROJECT ID 0918-00-392

DISTRICT Dallas  
HIGHWAY Various

COUNTY Dallas

CONTROL SECTION JOB				0918-00-392		TOTAL EST.	TOTAL FINAL
PROJECT ID				A00189293			
COUNTY				Dallas			
HIGHWAY				Various			
ALT	BID CODE	DESCRIPTION	UNIT	EST.	FINAL		
	686-7028	INS TRF SIG PL AM(S)1 ARM(24')LUM&ILSN	EA	1.000		1.000	
	686-7029	INS TRF SIG PL AM (S)1 ARM(28')	EA	1.000		1.000	
	686-7030	INS TRF SIG PL AM(S)1 ARM(28')ILSN	EA	1.000		1.000	
	686-7031	INS TRF SIG PL AM(S)1 ARM(28')LUM	EA	2.000		2.000	
	686-7032	INS TRF SIG PL AM(S)1 ARM(28')LUM&ILSN	EA	1.000		1.000	
	686-7033	INS TRF SIG PL AM(S)1 ARM(32')	EA	1.000		1.000	
	686-7034	INS TRF SIG PL AM(S)1 ARM(32')ILSN	EA	1.000		1.000	
	686-7035	INS TRF SIG PL AM(S)1 ARM(32')LUM	EA	2.000		2.000	
	686-7036	INS TRF SIG PL AM(S)1 ARM(32')LUM&ILSN	EA	1.000		1.000	
	686-7037	INS TRF SIG PL AM(S)1 ARM(36')	EA	1.000		1.000	
	686-7038	INS TRF SIG PL AM(S)1 ARM(36')ILSN	EA	1.000		1.000	
	686-7039	INS TRF SIG PL AM(S)1 ARM(36')LUM	EA	2.000		2.000	
	686-7040	INS TRF SIG PL AM(S)1 ARM(36')LUM&ILSN	EA	1.000		1.000	
	686-7041	INS TRF SIG PL AM(S)1 ARM(40')	EA	1.000		1.000	
	686-7042	INS TRF SIG PL AM(S)1 ARM(40')ILSN	EA	1.000		1.000	
	686-7043	INS TRF SIG PL AM(S)1 ARM(40')LUM	EA	2.000		2.000	
	686-7044	INS TRF SIG PL AM(S)1 ARM(40')LUM&ILSN	EA	1.000		1.000	
	686-7045	INS TRF SIG PL AM(S)1 ARM(44')	EA	1.000		1.000	
	686-7046	INS TRF SIG PL AM(S)1 ARM(44')ILSN	EA	1.000		1.000	
	686-7047	INS TRF SIG PL AM(S)1 ARM(44')LUM	EA	2.000		2.000	
	686-7048	INS TRF SIG PL AM(S)1 ARM(44')LUM&ILSN	EA	1.000		1.000	
	686-7049	INS TRF SIG PL AM(S)1 ARM(48')	EA	1.000		1.000	
	686-7050	INS TRF SIG PL AM(S)1 ARM(48')ILSN	EA	1.000		1.000	
	686-7051	INS TRF SIG PL AM(S)1 ARM(48')LUM	EA	2.000		2.000	
	686-7052	INS TRF SIG PL AM(S)1 ARM(48')LUM&ILSN	EA	1.000		1.000	
	686-7057	INS TRF SIG PL AM(S)1 ARM(55')	EA	1.000		1.000	
	686-7058	INS TRF SIG PL AM(S)1 ARM(55')ILSN	EA	1.000		1.000	
	686-7059	INS TRF SIG PL AM(S)1 ARM(55')LUM	EA	2.000		2.000	
	686-7060	INS TRF SIG PL AM(S)1 ARM(55')LUM&ILSN	EA	1.000		1.000	
	686-7061	INS TRF SIG PL AM(S)1 ARM(60')	EA	1.000		1.000	
	686-7062	INS TRF SIG PL AM(S)1 ARM(60')ILSN	EA	1.000		1.000	
	686-7063	INS TRF SIG PL AM(S)1 ARM(60')LUM	EA	2.000		2.000	
	686-7064	INS TRF SIG PL AM(S)1 ARM(60')LUM&ILSN	EA	1.000		1.000	
	686-7065	INS TRF SIG PL AM(S)1 ARM(65')	EA	1.000		1.000	
	686-7066	INS TRF SIG PL AM(S)1 ARM(65')ILSN	EA	1.000		1.000	
	686-7067	INS TRF SIG PL AM(S)1 ARM(65')LUM	EA	2.000		2.000	
	686-7068	INS TRF SIG PL AM(S)1 ARM(65')LUM&ILSN	EA	1.000		1.000	



DISTRICT	COUNTY	CCSJ	SHEET
Dallas	Dallas	0918-00-392	4F



# Estimate & Quantity Sheet

CONTROLLING PROJECT ID 0918-00-392

DISTRICT Dallas  
HIGHWAY Various

COUNTY Dallas

CONTROL SECTION JOB				0918-00-392		TOTAL EST.	TOTAL FINAL
PROJECT ID				A00189293			
COUNTY				Dallas			
HIGHWAY				Various			
ALT	BID CODE	DESCRIPTION	UNIT	EST.	FINAL		
	686-7282	RELOC TRF SG PL AM(S)SNGL MST ARM POLE	EA	1.000		1.000	
	686-7283	RELOC TRF SG PL AM (S) (STRAIN POLE)	EA	1.000		1.000	
	687-7001	PED POLE ASSEMBLY	EA	16.000		16.000	
	688-7001	PED DETECT PUSH BUTTON (APS)	EA	16.000		16.000	
	688-7003	PED DETECTOR CONTROLLER UNIT	EA	4.000		4.000	
	688-7004	VEH LP DETECT (SAWCUT)	LF	200.000		200.000	
	6006-7001	VIVDS PROSR SYS	EA	1.000		1.000	
	6006-7002	VIVDS CAM ASSY FXD LNS	EA	2.000		2.000	
	6006-7003	VIVDS CAM ASSY VAR LNS	EA	2.000		2.000	
	6006-7004	VIVDS CAM ASSY 360	EA	1.000		1.000	
	6006-7005	VIVDS CNTRL SOFTWARE	EA	1.000		1.000	
	6006-7007	VIVDS CABLING	LF	500.000		500.000	
	6006-7010	VIVDS CAM ASSY (INSTALL ONLY)	EA	5.000		5.000	
	6006-7012	VIVDS CABLING (INSTALL ONLY)	LF	1,000.000		1,000.000	
	6007-7001	BBU SYSTEM (EXTERNAL BATTERY CABINET)	EA	6.000		6.000	
	6007-7002	BBU SYSTEM (STAND-ALONE BATT CABINET)	EA	2.000		2.000	
	6008-7001	RVDS (PRESENCE DETECTION ONLY)	EA	8.000		8.000	
	6008-7002	RVDS (ADVANCE DETENTION ONLY)	EA	2.000		2.000	
	6008-7003	RVDS (PRESENCE AND ADVANCE DETECTION)	EA	8.000		8.000	
	6008-7004	RVDS (PRESENCE DET)(INSTALL ONLY)	EA	1.000		1.000	
	6008-7005	RVDS (ADVANCE DET)(INSTALL ONLY)	EA	1.000		1.000	
	6008-7006	RVDS (PRES AND ADV)(INSTALL ONLY)	EA	1.000		1.000	
	6008-7007	RELOCATE RVDS	EA	1.000		1.000	
	6008-7008	REMOVE RVDS	EA	1.000		1.000	
	6013-7006	GROUND BOX (PREPARE)	EA	4.000		4.000	
	02	RAILROAD FORCE ACCOUNT WORK (NON-PART)	LS	1.000		1.000	
	04	PUBLIC UTILITY FORCE ACCT WORK (NON-PART)	LS	1.000		1.000	
	06	MATERIAL FURNISHED BY THE STATE (NON-PART)	LS	1.000		1.000	
	08	EROSION CONTROL MAINTENANCE: CONTRACTOR FORCE ACCOUNT WORK (NON-PART)	LS	1.000		1.000	
		SAFETY CONTINGENCY: CONTRACTOR FORCE ACCOUNT WORK (NON-PART)	LS	1.000		1.000	
	32	MATERIALS FURNISHED BY CITY (NON- PART)	LS	1.000		1.000	

DISCLAIMER: The use of this standard is governed by the "Texas Engineering Practice Act". No warranty of any kind is made by TxDOT for any purpose whatsoever. TxDOT assumes no responsibility for the conversion of this standard to other formats or for incorrect results or damages resulting from its use.

DATE: 2/13/2024 10:22:09 AM  
 U:\TRAFFIC PROJECTS\0918-00-392 Non-Site 9-24\Microstation Files\005-006 WZ(BTS)-13.dgn

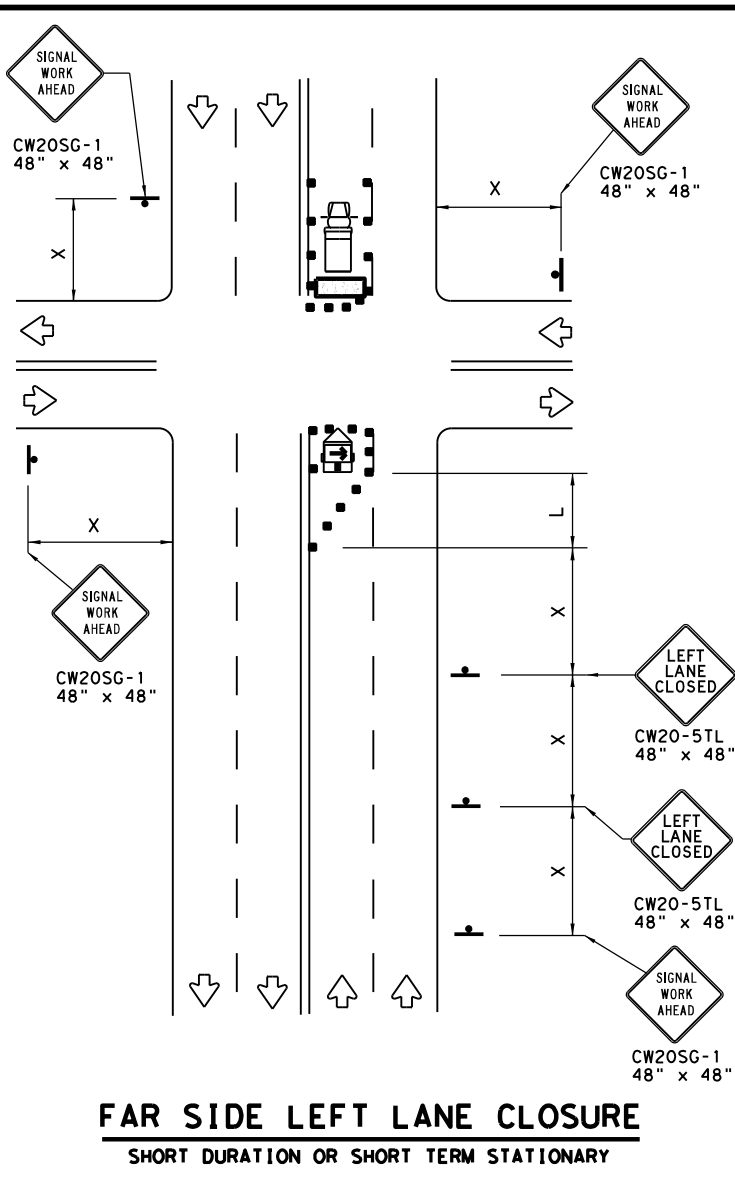
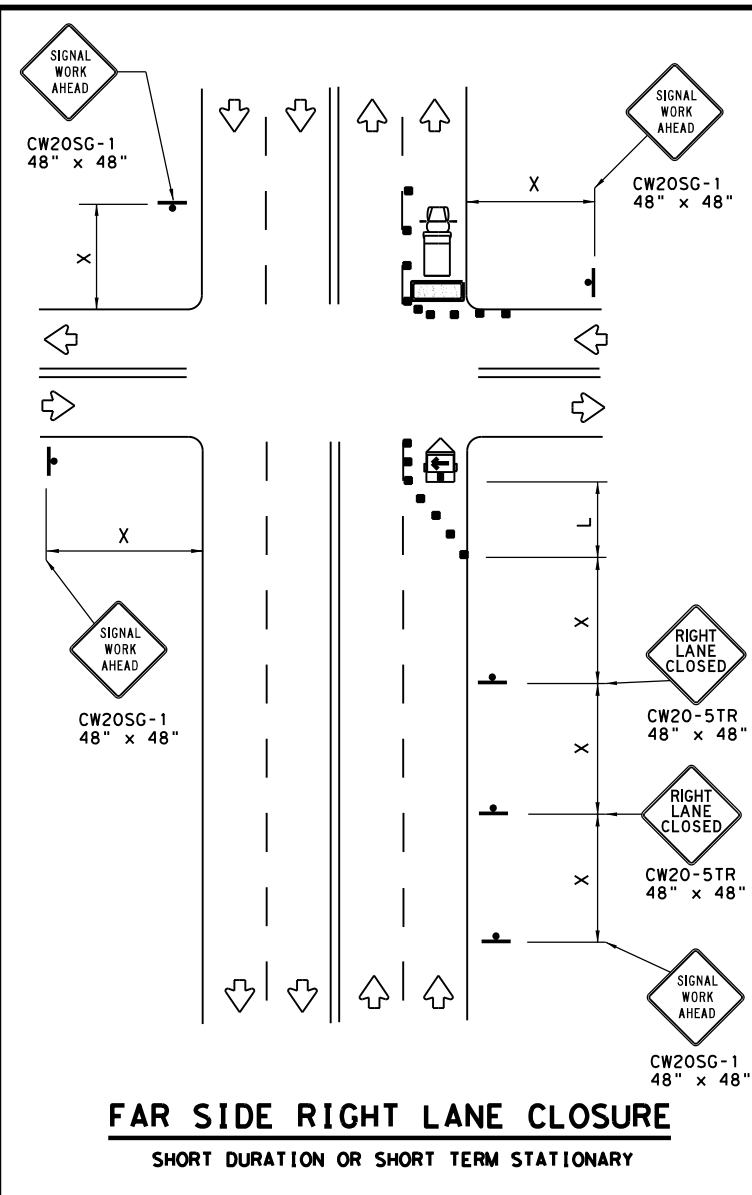
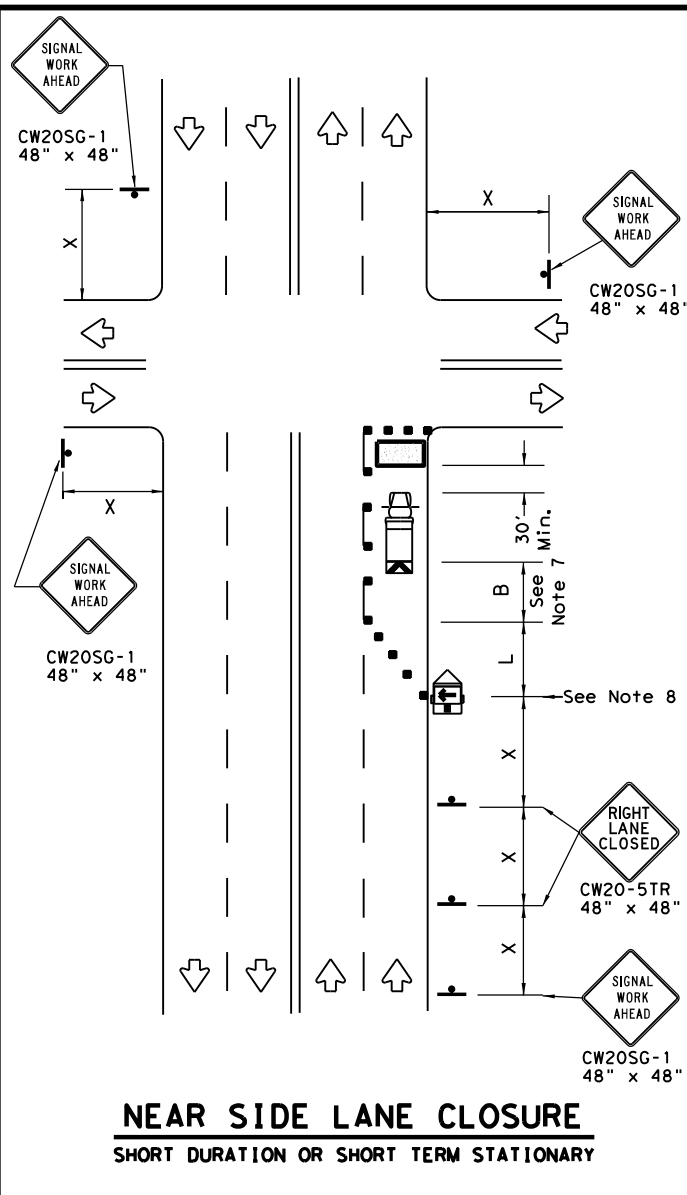

LEGEND			
	Type 3 Barricade		Channelizing Devices
	Heavy Work Vehicle		Truck Mounted Attenuator (TMA)
	Trailer Mounted Flashing Arrow Board		Portable Changeable Message Sign (PCMS)
	Sign		Traffic Flow
	Flag		Flagger

Posted Speed *	Formula	Minimum Desirable Taper Lengths **			Suggested Maximum Spacing of Channelizing Devices		Minimum Sign Spacing "X" Distance	Suggested Longitudinal Buffer Space "B"
		10' Offset	11' Offset	12' Offset	On a Taper	On a Tangent		
30	$L = \frac{WS^2}{60}$	150'	165'	180'	30'	60'	120'	90'
35		205'	225'	245'	35'	70'	160'	120'
40		265'	295'	320'	40'	80'	240'	155'
45	L = WS	450'	495'	540'	45'	90'	320'	195'
50		500'	550'	600'	50'	100'	400'	240'
55		550'	605'	660'	55'	110'	500'	295'
60		600'	660'	720'	60'	120'	600'	350'
65		650'	715'	780'	65'	130'	700'	410'
70		700'	770'	840'	70'	140'	800'	475'
75		750'	825'	900'	75'	150'	900'	540'

\* Conventional Roads Only  
 \*\* Taper lengths have been rounded off.  
 L=Length of Taper (FT) W=Width of Offset (FT) S=Posted Speed (MPH)

**WORKERS IN BUCKET TRUCKS SHALL NOT WORK ABOVE OPEN LANES OF TRAFFIC.**

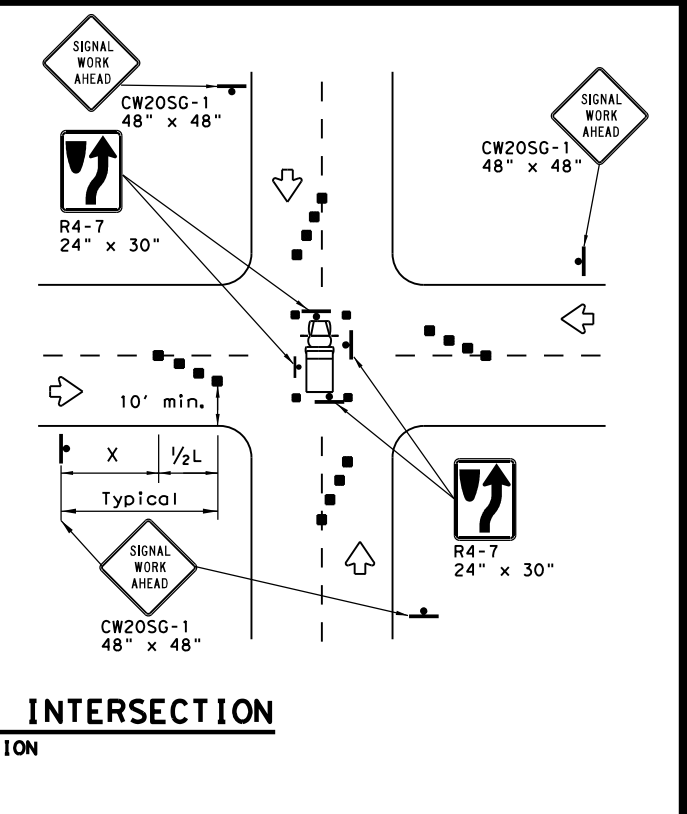
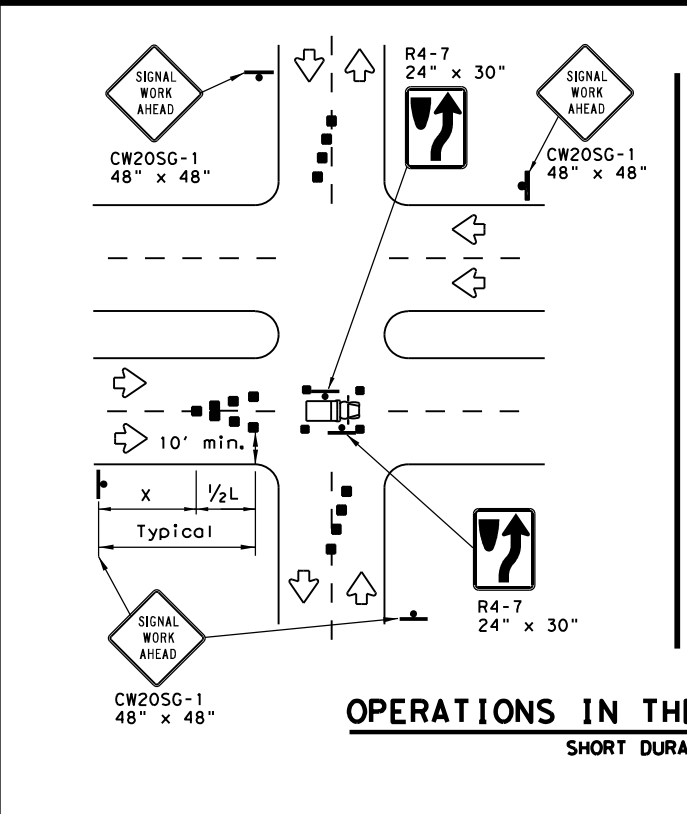

**GENERAL NOTES**

- The minimum size channelizing device is the 28" cone. 42" Two-piece cones, drums, vertical panels or barricades will be required when the device must be left unattended at night.
- Obstructions or hazards at the work area shall be clearly marked and delineated at all times.
- Flaggers and Flagger Symbol (CW20-7) signs may be required according to field conditions.
- Vehicles parked in roadway shall be equipped with at least two high intensity rotating, flashing, oscillating or strobe type lights.
- High level warning devices (flag trees) may be used at corners of the vehicle.
- When work operations are performed on existing signals, the signals may be placed in flashing red mode when approved by the engineer. If existing signals do not have power, All-Way Stop (R1-1 and R1-3P) signs may be implemented when approved by the engineer.
- For Short-Term Stationary work the buffer space "B" from the above table should be used if field conditions permit. For Short Duration (less than 1 hour) any buffer space provided will enhance the safety of the setup.
- The arrow board at this location may be omitted for Short Duration work if the work vehicle has an arrow board in operation. As an option, the arrow board may be placed at the end of the taper in the closed lane if space is not available at the beginning of the taper.
- Signs and devices for the NEAR SIDE LANE CLOSURE may be altered for a left lane closure by using a LEFT LANE CLOSED (CW20-5TL) and adding channelizing devices on the centerline to protect the work space from opposing traffic.

Texas Department of Transportation  
 Traffic Operations Division Standard

**TRAFFIC SIGNAL WORK TYPICAL DETAILS**

**WZ(BTS-1)-13**

FILE: wzbts-13.dgn	DN: TxDOT	CR: TxDOT	DW: TxDOT	CK: TxDOT
© TxDOT April 1992	CONT	SECT	JOB	HIGHWAY
REVISIONS	0918	00	392	VA
2-98 10-99 7-13	DIST	COUNTY	SHEET NO.	
4-98 3-03	DAL	DALLAS, ETC.	5	

DISCLAIMER: The use of this standard is governed by the "Texas Engineering Practice Act". No warranty of any kind is made by TxDOT for any purpose whatsoever. TxDOT assumes no responsibility for the conversion of this standard to other formats or for incorrect use or damages resulting from its use.

DATE: 2/13/2024 10:22:42 AM  
 U:\TRAFFIC PROJECTS\0918-00-392 Non-Site 9-24\Traf\construction Files\005-006 WZ(BTS)-13.dgn

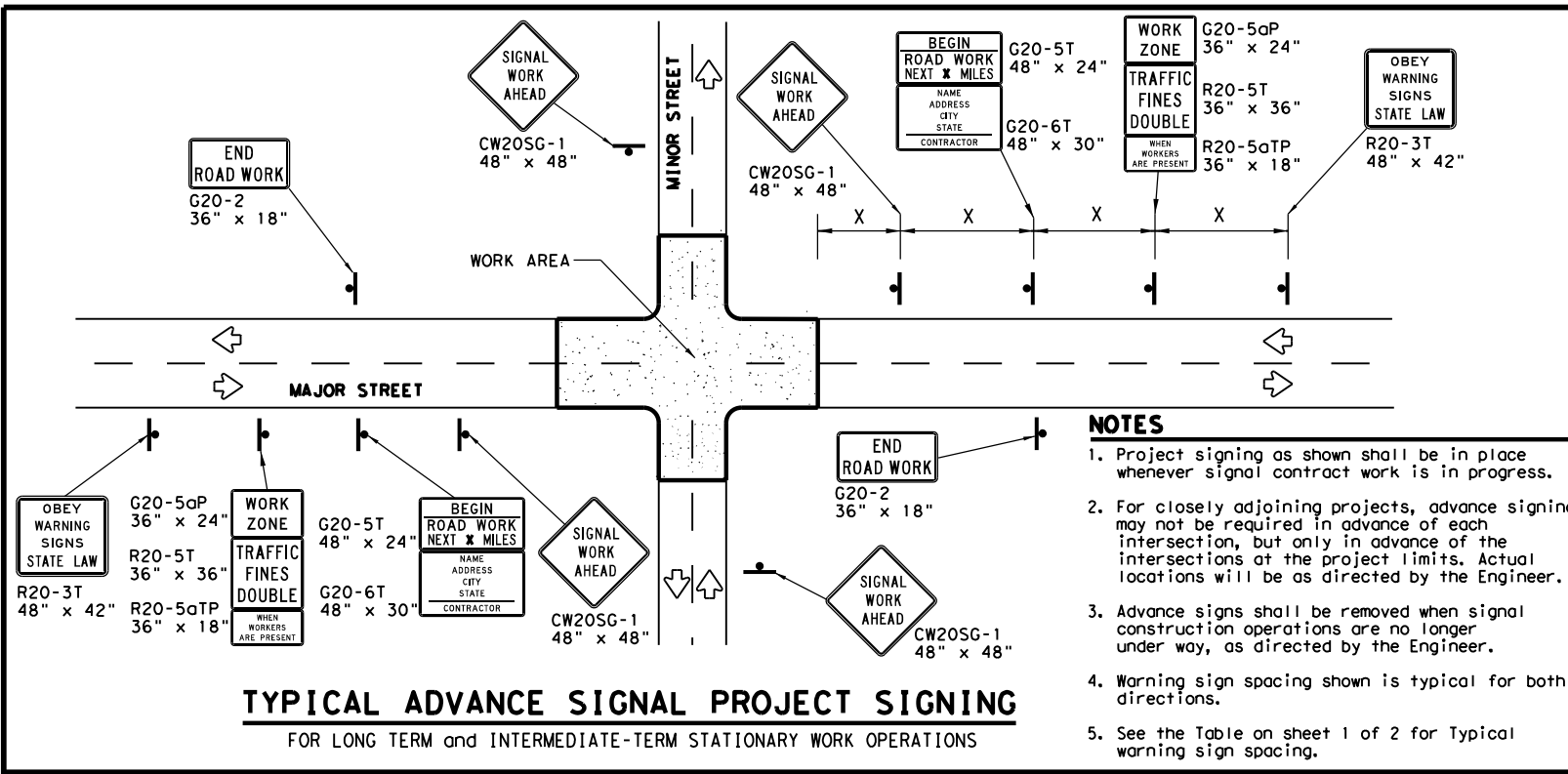

- NOTES**
1. Project signing as shown shall be in place whenever signal contract work is in progress.
  2. For closely adjoining projects, advance signing may not be required in advance of each intersection, but only in advance of the intersections at the project limits. Actual locations will be as directed by the Engineer.
  3. Advance signs shall be removed when signal construction operations are no longer under way, as directed by the Engineer.
  4. Warning sign spacing shown is typical for both directions.
  5. See the Table on sheet 1 of 2 for Typical warning sign spacing.

**GENERAL NOTES FOR WORK ZONE SIGNS**

1. Signs shall be installed and maintained in a straight and plumb condition.
2. Wooden sign posts shall be painted white.
3. Barricades shall NOT be used as sign supports.
4. Nails shall NOT be used to attach signs to any support.
5. All signs shall be installed in accordance with the plans or as directed by the Engineer.
6. The Contractor shall furnish the sign design shown in the plans or in the "Standard Highway Sign Designs for Texas" (SHSD).
7. The Contractor shall furnish sign supports and substrates listed in the "Compliant Work Zone Traffic Control Device List" (CWZTCD), installed as per the manufacturer's recommendations.
8. Temporary signs that have damaged or cracked substrates and/or damaged or marred reflective sheeting shall be replaced as directed by the Engineer.
9. Identification markings may be shown only on the back of the sign substrate. The maximum height of letters and/or company logos used for identification shall be 1".
10. Damaged wood posts shall be replaced. Splicing wood posts will not be allowed.

**DURATION OF WORK**

1. Work zone durations are defined in Part 6, Section 60.02 of the Texas Manual on Uniform Traffic Control Devices (TMUTCD).

**SIGN MOUNTING HEIGHT**

1. Sign height of Long-term/Intermediate-term warning signs shall be as shown on Figure 6F-1 of the TMUTCD.
2. Sign height of Short-term/Short Duration warning signs shall be as shown on Figure 6F-2 of the TMUTCD.
3. Regulatory signs shall be mounted at least 7 feet, but not more than 9 feet, above the paved surface regardless of work duration.

**REMOVING OR COVERING**

1. When sign messages may be confusing or do not apply, the signs shall be removed or completely covered, unless otherwise approved by the Engineer.
2. When signs are covered, the material used shall be opaque, such as heavy mil black plastic, or other materials which will cover the entire sign face and maintain their opaque properties under automobile headlights at night without damaging the sign sheeting. Burlap, or heavy materials such as plywood or aluminum shall not be used to cover signs.
3. Duct tape or other adhesive material shall NOT be affixed to a sign face.
4. Signs and anchor stubs shall be removed and holes back filled upon completion of the work.

**REFLECTIVE SHEETING**

1. All signs shall be retroreflective and constructed of sheeting meeting the requirements of the DMS and color usage table shown on this sheet.

**SIGN SUPPORT WEIGHTS**

1. Weights used to keep signs from turning over should be sandbags filled with dry, cohesionless material.
2. The sandbags will be tied shut to keep the sand from spilling and to maintain a constant weight.
3. Rock, concrete, iron, steel or other solid objects will not be permitted for use as sign support weights.
4. Sandbags should weigh a minimum of 35 lbs and a maximum of 50 lbs.
5. Sandbags shall be made of a durable material that tears upon vehicular impact. Rubber, such as fire inner tubes, shall not be used.
6. Rubber ballasts designed for channelizing devices should not be used for ballast on portable sign supports. Sign supports designed and manufactured with rubber bases may be used when shown on the CWZTCD list.
7. Sandbags shall only be placed along or laid over the base supports of the traffic control device and shall not be suspended above ground level or hung with rope, wire, chains or other fasteners. Sandbags shall be placed along the length of the skids to weigh down the sign support.
8. Sandbags shall NOT be placed under the skid and shall not be used to level sign supports placed on slopes.

**LEGEND**

	Sign
	Channelizing Devices
	Type 3 Barricade

**DEPARTMENTAL MATERIAL SPECIFICATIONS**

SIGN FACE MATERIALS	DMS-8300
FLEXIBLE ROLL-UP REFLECTIVE SIGNS	DMS-8310

COLOR	USAGE	SHEETING MATERIAL
ORANGE	BACKGROUND	TYPE B <sub>FL</sub> OR TYPE C <sub>FL</sub> SHEETING
WHITE	BACKGROUND	TYPE A SHEETING
BLACK	LEGEND & BORDERS	ACRYLIC NON-REFLECTIVE SHEETING

Only pre-qualified products shall be used. A copy of the "Compliant Work Zone Traffic Control Devices List" (CWZTCD) describes pre-qualified products and their sources and may be found at the following web address:  
[http://www.txdot.gov/txdot\\_library/publications/construction.htm](http://www.txdot.gov/txdot_library/publications/construction.htm)

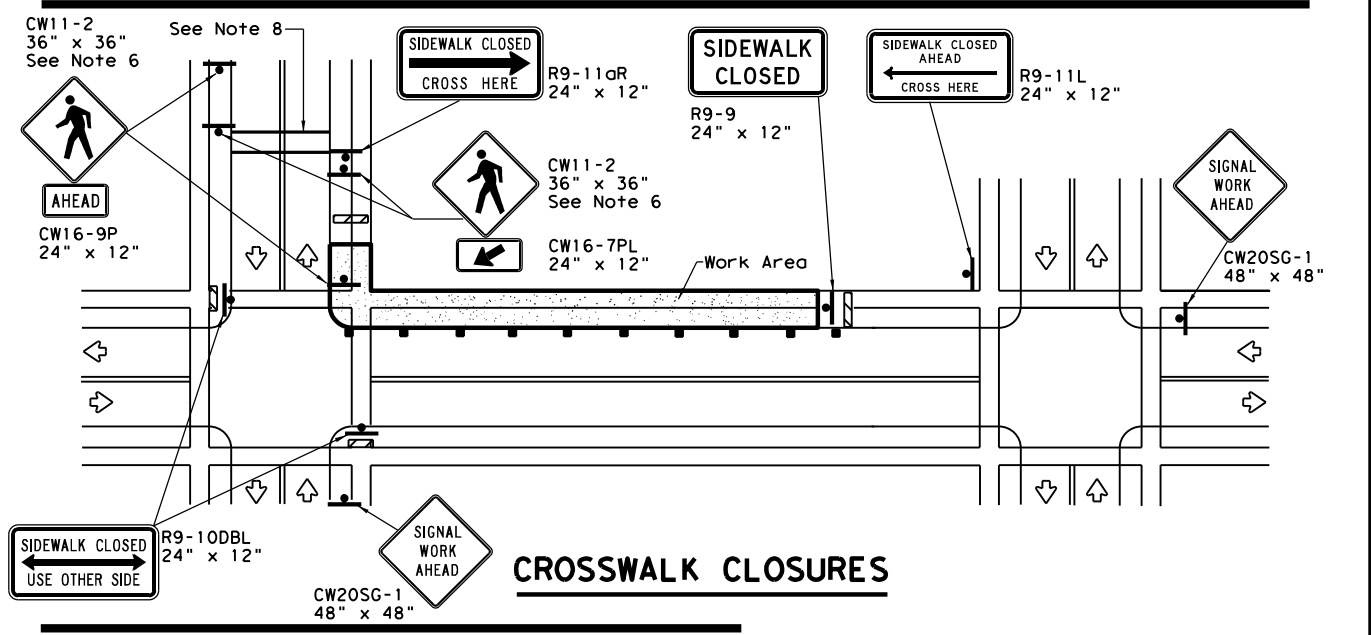
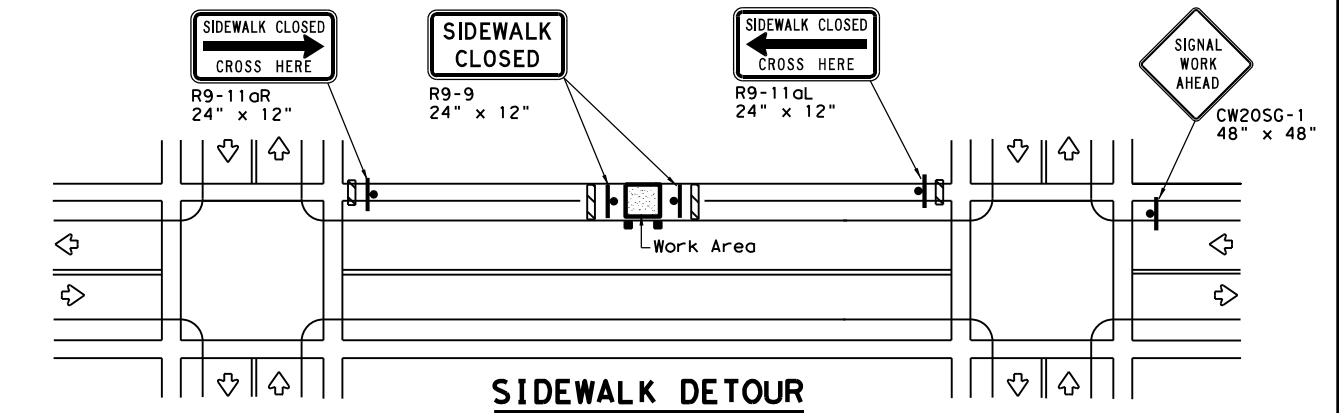
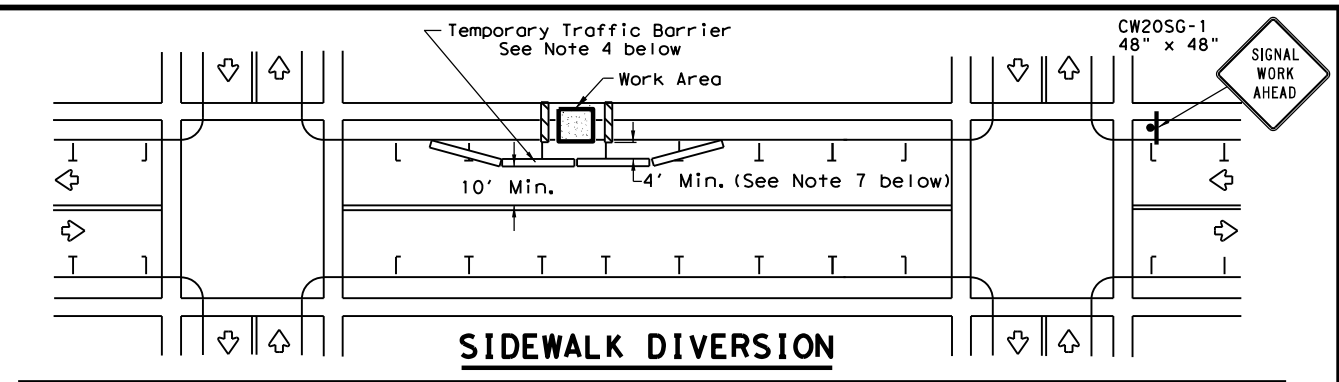

**PEDESTRIAN CONTROL**

1. Holes, trenches or other hazards shall be adequately protected by covering, delineating or surrounding the hazard with orange plastic pedestrian fencing or longitudinal channelizing devices, or as directed by the Engineer.
2. "CROSSWALK CLOSURES" as detailed above will require the Engineer's approval prior to installation.
3. R9 series signs shown may be placed on supports detailed on the BC standards or CWZTCD list, or when fabricated from approved lightweight plastic substrates, they may be mounted on top of a plastic drum at or near the location shown.
4. For speeds less than 45 mph longitudinal channelizing devices may be used instead of traffic barriers when approved by the Engineer. Attenuation of blunt ends and installation of water filled devices shall be as per BC(9) and manufacturer's recommendations.
5. Location of devices are for general guidance. Actual device spacing and location must be field adjusted to meet actual conditions.
6. Where pedestrians with visual disabilities normally use the closed sidewalk Detectable Pedestrian Barricades should be used instead of the Type 3 Barricades shown.
7. The width of existing sidewalk should be maintained if practical.
8. Pavement markings for mid-block crosswalks shall be paid for under the appropriate bid items.
9. When crosswalks or other pedestrian facilities are closed or relocated, temporary facilities shall be detectable and shall include accessibility features consistent with the features present in the existing pedestrian facility.

SHEET 2 OF 2

Texas Department of Transportation  
 Traffic Operations Division Standard

**TRAFFIC SIGNAL WORK BARRICADES AND SIGNS**

**WZ(BTS-2)-13**

FILE: wzbts-13.dgn	DN: TxDOT	CK: TxDOT	DW: TxDOT	CK: TxDOT
©TxDOT April 1992	CONT	SECT	JOB	HIGHWAY
REVISIONS	091800		392	VA
2-98 10-99 7-13	DIST	COUNTY	SHEET NO.	
4-98 3-03	DAL	DALLAS, ETC.	6	

DISCLAIMER: The use of this standard is governed by the "Texas Engineering Practice Act". No warranty of any kind is made by TxDOT for any purpose whatsoever. TxDOT assumes no responsibility for the conversion of this standard to other formats or for incorrect results or damages resulting from its use.

Warning sign and rumble strip sequence in opposite direction is same as below.

Flagger to Flagger (Length of Work Area)	ADT	# of Rumble Strip Arrays
1/8 Mile	< 4,500	1
	≥ 4,500	2
1/4 Mile	< 3,500	1
	≥ 3,500	2
1/2 Mile	< 2,600	1
	≥ 2,600	2
1 Mile	< 1,600	1
	≥ 1,600	2
> 1 Mile	N/A	2

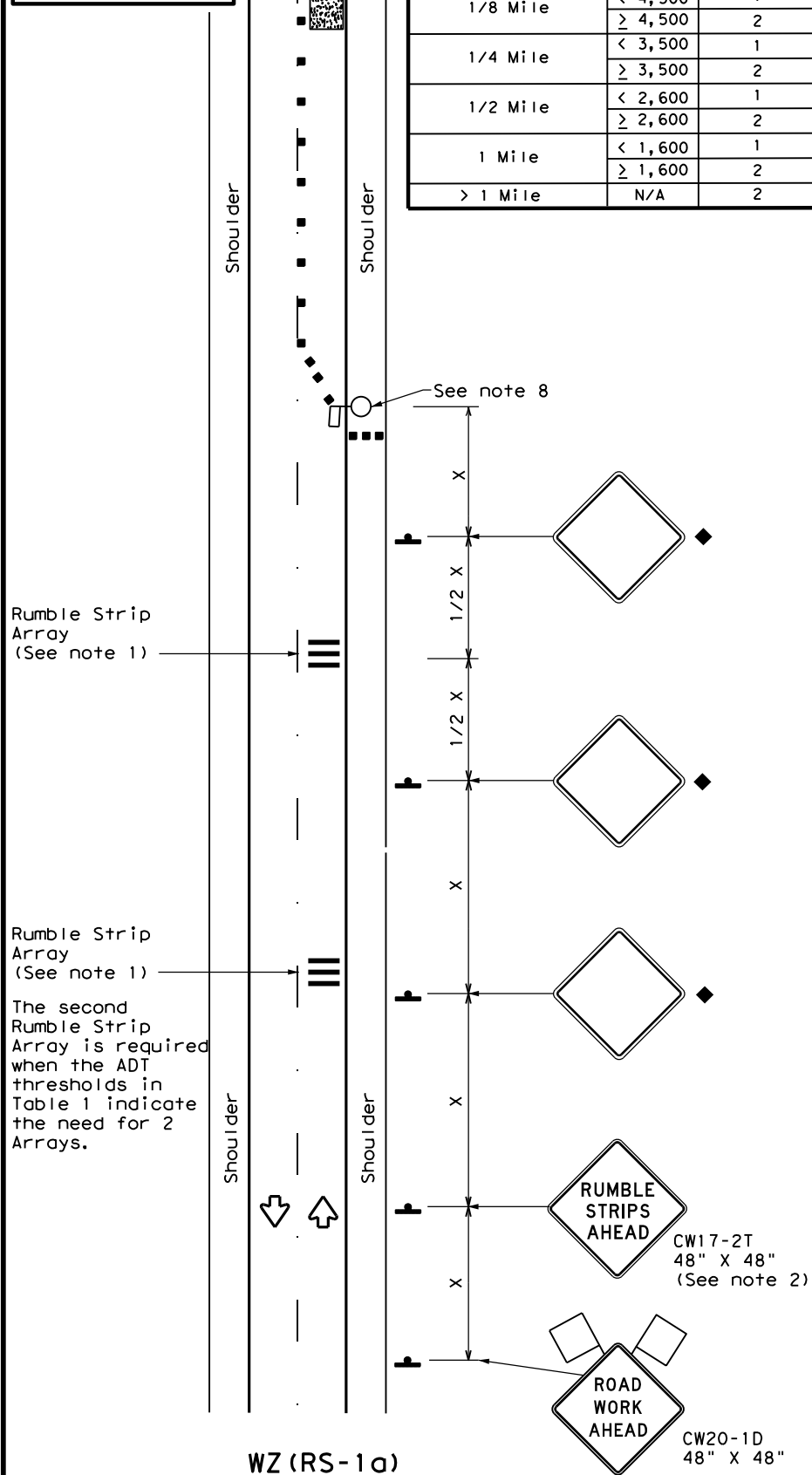

WZ (RS-1a)

**RUMBLE STRIPS ON ONE-LANE TWO-WAY APPLICATION**

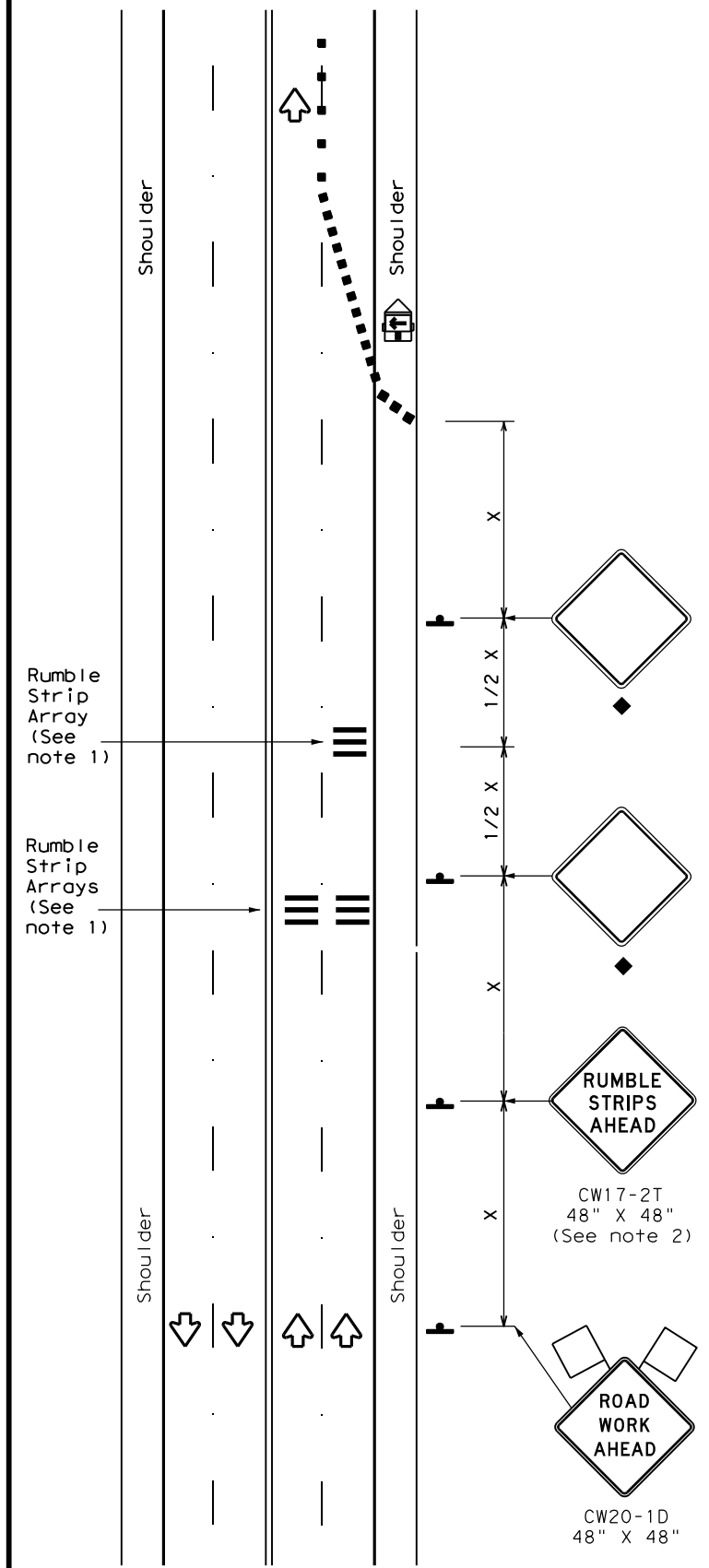

WZ (RS-1b)

**RUMBLE STRIPS FOR LANE CLOSURE ON CONVENTIONAL ROADWAY**

**GENERAL NOTES**

- Each Rumble Strip Array should consist of three rumble strips spaced center to center at the spacing shown in Table 2, placed transverse across the lane at locations shown.
- The CW17-2T "RUMBLE STRIPS AHEAD" sign should be located after the CW20-1D "ROAD WORK AHEAD" sign and spaced as shown. If traffic is observed to be queuing, or is expected to queue beyond the Rumble Strips, the CW17-2T sign and the first Rumble Strip Array may be located upstream of the CW20-1D sign as necessary to provide needed warning.
- Temporary Rumble Strips will be considered subsidiary to Item 502, and shall be a product listed on the Compliant Work Zone Traffic Control Devices.
- Remove Temporary Rumble Strips before removing the advanced warning signs.
- Temporary Rumble Strips should not be used on horizontal curves, loose gravel, soft or bleeding asphalt, heavily rutted pavements or unpaved surfaces.
- Temporary Rumble Strips shall be installed and maintained as per manufacturer's recommendations.
- This standard sheet shall be used in conjunction with other appropriate TCP standard, TMUTCD typical application or project specific detail for the project.
- The one-lane two-way application may utilize a flagger, an Automated Flagger Assistance Device (AFAD) or a Portable Traffic Signal (PTS).
- Replace defective Temporary Rumble Strips as directed by the Engineer.
- Temporary Rumble Strips may be used on freeways or expressways based on engineering judgment and written direction from the Engineer.

Speed	Approximate distance between strips in an array
≤ 40 MPH	10'
> 40 MPH & ≤ 55 MPH	15'
= 60 MPH	20'
≥ 65 MPH	* 35' +

	Type 3 Barricade		Channelizing Devices
	Heavy Work Vehicle		Truck Mounted Attenuator (TMA)
	Trailer Mounted Flashing Arrow Panel		Portable Changeable Message Sign (PCMS)
	Sign		Traffic Flow
	Flag		Flagger

Posted Speed *	Formula	Minimum Desirable Taper Lengths **			Suggested Maximum Spacing of Channelizing Devices		Minimum Sign Spacing "x" Distance	Suggested Longitudinal Buffer Space "B"
		10' Offset	11' Offset	12' Offset	On a Taper	On a Tangent		
30	L = WS/2	150'	165'	180'	30'	60'	120'	90'
35		205'	225'	245'	35'	70'	160'	120'
40	L = WS	265'	295'	320'	40'	80'	240'	155'
45		450'	495'	540'	45'	90'	320'	195'
50	L = WS	500'	550'	600'	50'	100'	400'	240'
55		550'	605'	660'	55'	110'	500'	295'
60	L = WS	600'	660'	720'	60'	120'	600'	350'
65		650'	715'	780'	65'	130'	700'	410'
70	L = WS	700'	770'	840'	70'	140'	800'	475'
75		750'	825'	900'	75'	150'	900'	540'

\* Conventional Roads Only  
 \*\* Taper lengths have been rounded off.  
 L=Length of Taper (FT) W=Width of Offset (FT)  
 S=Posted Speed (MPH)

MOBILE	SHORT DURATION	SHORT TERM STATIONARY	INTERMEDIATE TERM STATIONARY	LONG TERM STATIONARY
	✓	✓		

◆ Signs are for illustrative purposes only. Signs required may vary depending on the TCP, TMUTCD Typical Application, or project specific details for the project.

\* For posted speeds in excess of 65 MPH, it is recommended that spacing is increased as speed limits increase. Increasing space between rumble strips will improve effectiveness.

Texas Department of Transportation Traffic Safety Division Standard

## TEMPORARY RUMBLE STRIPS

### WZ (RS) - 22

FILE: wzrs22.dgn	DN: TxDOT	CK: TxDOT	DW: TxDOT	CK: TxDOT
© TxDOT November 2012	CONT	SECT	JOB	HIGHWAY
REVISIONS	0918	00	392	VA
2-14 1-22	DIST	COUNTY	SHEET NO.	
4-16	DAL	DALLAS, ETC.	7	

DATE:  
FILE:

DISCLAIMER: The use of this standard is governed by the "Texas Engineering Practice Act". No warranty of any kind is made by TxDOT for any purpose whatsoever. TxDOT assumes no responsibility for the conversion of this standard to other formats or for incorrect results or damages resulting from its use.

DATE:  
 FILE:

**BARRICADE AND CONSTRUCTION (BC) STANDARD SHEETS GENERAL NOTES:**

- The Barricade and Construction Standard Sheets (BC sheets) are intended to show typical examples for placement of temporary traffic control devices, construction pavement markings, and typical work zone signs. The information contained in these sheets meet or exceed the requirements shown in the "Texas Manual on Uniform Traffic Control Devices" (TMUTCD).
- The development and design of the Traffic Control Plan (TCP) is the responsibility of the Engineer.
- The Contractor may propose changes to the TCP that are signed and sealed by a licensed professional engineer for approval. The Engineer may develop, sign and seal Contractor proposed changes.
- The Contractor is responsible for installing and maintaining the traffic control devices as shown in the plans. The Contractor may not move or change the approximate location of any device without the approval of the Engineer.
- Geometric design of lane shifts and detours should, when possible, meet the applicable design criteria contained in manuals such as the American Association of State Highway and Transportation Officials (AASHTO), "A Policy on Geometric Design of Highways and Streets," the TxDOT "Roadway Design Manual" or engineering judgment.
- When projects abut, the Engineer(s) may omit the END ROAD WORK, TRAFFIC FINES DOUBLE, and other advance warning signs if the signing would be redundant and the work areas appear continuous to the motorists. If the adjacent project is completed first, the Contractor shall erect the necessary warning signs as shown on these sheets, the TCP sheets or as directed by the Engineer. The BEGIN ROAD WORK NEXT X MILES sign shall be revised to show appropriate work zone distance.
- The Engineer may require duplicate warning signs on the median side of divided highways where median width will permit and traffic volumes justify the signing.
- All signs shall be constructed in accordance with the details found in the "Standard Highway Sign Designs for Texas," latest edition. Sign details not shown in this manual shall be shown in the plans or the Engineer shall provide a detail to the Contractor before the sign is manufactured.
- The temporary traffic control devices shown in the illustrations of the BC sheets are examples. As necessary, the Engineer will determine the most appropriate traffic control devices to be used.
- Where highway construction or maintenance work is being undertaken, other than mobile operations as defined by the Texas Manual on Uniform Traffic Control Devices, CSJ limit signs are required. CSJ limit signs are shown on BC(2). The OBEY WARNING SIGNS STATE LAW sign, STAY ALERT TALK OR TEXT LATER and the WORK ZONE TRAFFIC FINES DOUBLE sign with plaque shall be erected in advance of the CSJ limits. The BEGIN ROAD WORK NEXT X MILES, CONTRACTOR and END ROAD WORK signs shall be erected at or near the CSJ limits. For mobile operations, CSJ limit signs are not required.
- Traffic control devices should be in place only while work is actually in progress or a definite need exists.
- The Engineer has the final decision on the location of all traffic control devices.
- Inactive equipment and work vehicles, including workers' private vehicles must be parked away from travel lanes. They should be as close to the right-of-way line as possible, or located behind a barrier or guardrail, or as approved by the Engineer.

**WORKER SAFETY NOTES:**

- Workers on foot who are exposed to traffic or to construction equipment within the right-of-way shall wear high-visibility safety apparel meeting the requirements of ISEA "American National Standard for High-Visibility Apparel," or equivalent revisions, and labeled as ANSI 107-2004 standard performance for Class 2 or 3 risk exposure. Class 3 garments should be considered for high traffic volume work areas or night time work.
- Except in emergency situations, flagger stations shall be illuminated when flagging is used at night.

**COMPLIANT WORKZONE TRAFFIC CONTROL DEVICES**

- Only pre-qualified products shall be used. The "Compliant Work Zone Traffic Control Devices List" (CWZTCD) describes pre-qualified products and their sources.
- Work zone traffic control devices shall be compliant with the Manual for Assessing safety Hardware (MASH).

<b>THE DOCUMENTS BELOW CAN BE FOUND ON-LINE AT</b> <a href="http://www.txdot.gov">http://www.txdot.gov</a>
COMPLIANT WORK ZONE TRAFFIC CONTROL DEVICES LIST (CWZTCD)
DEPARTMENTAL MATERIAL SPECIFICATIONS (DMS)
MATERIAL PRODUCER LIST (MPL)
ROADWAY DESIGN MANUAL - SEE "MANUALS (ONLINE MANUALS)"
STANDARD HIGHWAY SIGN DESIGNS FOR TEXAS (SHSD)
TEXAS MANUAL ON UNIFORM TRAFFIC CONTROL DEVICES (TMUTCD)
TRAFFIC ENGINEERING STANDARD SHEETS

SHEET 1 OF 12

 Texas Department of Transportation		Traffic Safety Division Standard	
<b>BARRICADE AND CONSTRUCTION GENERAL NOTES AND REQUIREMENTS</b>			
<b>BC (1) - 21</b>			
FILE:	bc-21.dgn	DN:	TxDOT
© TxDOT	November 2002	CK:	TxDOT
		DW:	TxDOT
		CR:	TxDOT
REVISIONS	CONT	SECT	JOB
4-03 7-13	0918	00	392
9-07 8-14			VA
5-10 5-21	DIST	COUNTY	SHEET NO.
	DAL	DALLAS, ETC.	8



DISCLAIMER: The use of this standard is governed by the "Texas Engineering Practice Act". No warranty of any kind is made by TxDOT for any purpose whatsoever. TxDOT assumes no responsibility for the conversion of this standard to other formats or for incorrect results or damages resulting from its use.

**TYPICAL LOCATION OF CROSSROAD SIGNS**

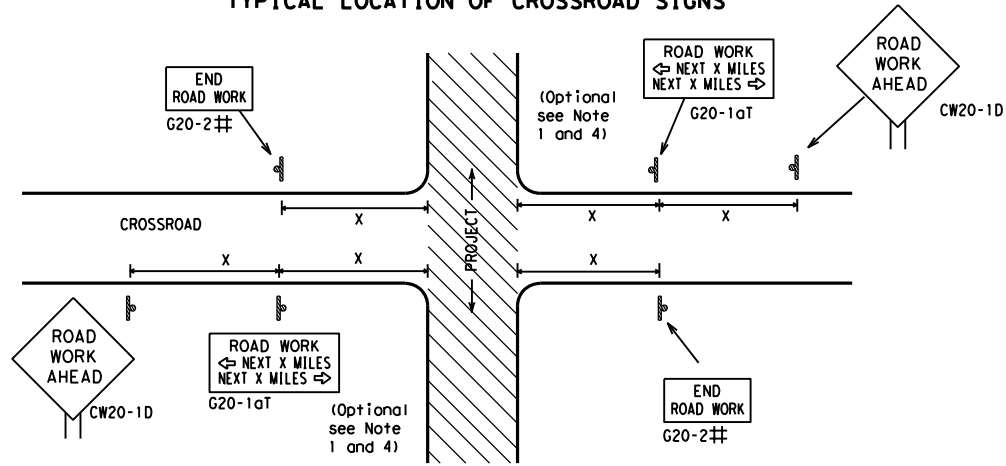

# May be mounted on back of "ROAD WORK AHEAD" (CW20-1D) sign with approval of Engineer. (See note 2 below)

- The typical minimum signing on a crossroad approach should be a "ROAD WORK AHEAD" (CW20-1D) sign and a (G20-2) "END ROAD WORK" sign, unless noted otherwise in plans.
- The Engineer may use the reduced size 36" x 36" ROAD WORK AHEAD (CW20-1D) sign mounted back to back with the reduced size 36" x 18" "END ROAD WORK" (G20-2) sign on low volume crossroads (see Note 4 under "Typical Construction Warning Sign Size and Spacing"). See the "Standard Highway Sign Designs for Texas" manual for sign details. The Engineer may omit the advance warning signs on low volume crossroads. The Engineer will determine whether a road is low volume as per TMUTCD Part 5. This information shall be shown in the plans.
- Based on existing field conditions, the Engineer/Inspector may require additional signs such as FLAGGER AHEAD, LOOSE GRAVEL, or other appropriate signs. When additional signs are required, these signs will be considered part of the minimum requirements. The Engineer/Inspector will determine the proper location and spacing of any sign not shown on the BC sheets, Traffic Control Plan sheets or the Work Zone Standard Sheets.
- The "ROAD WORK NEXT X MILES" (G20-1aT) sign shall be required at high volume crossroads to advise motorists of the length of construction in either direction from the intersection. The Engineer will determine whether a roadway is considered high volume.
- Additional traffic control devices may be shown elsewhere in the plans for higher volume crossroads.
- When work occurs in the intersection area, appropriate traffic control devices, as shown elsewhere in the plans or as determined by the Engineer/Inspector, shall be in place.

**T-INTERSECTION**

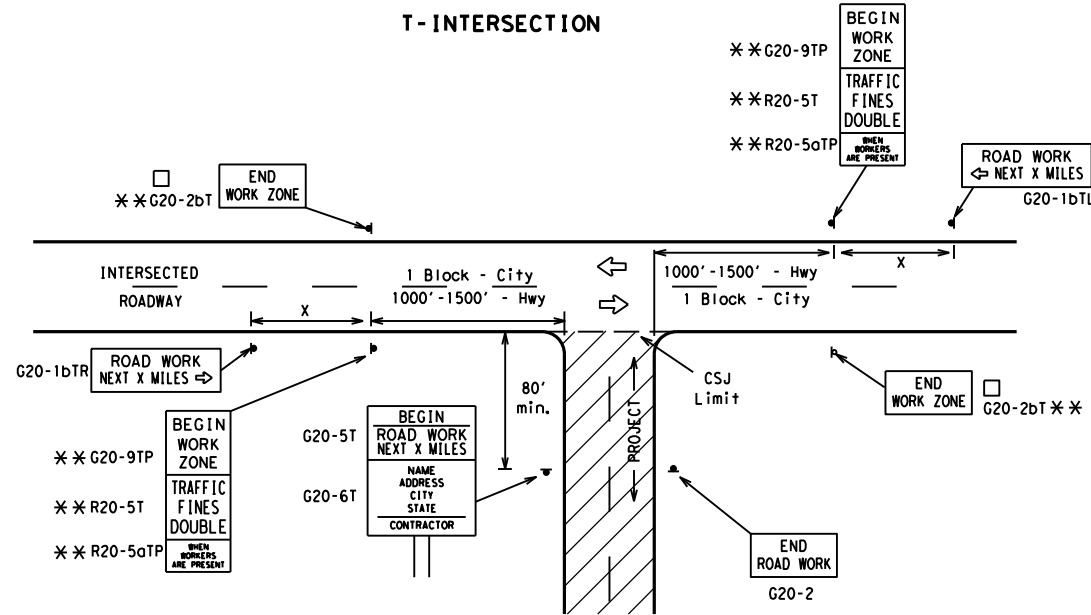

**CSJ LIMITS AT T-INTERSECTION**

- The Engineer will determine the types and location of any additional traffic control devices, such as a flagger and accompanying signs, or other signs, that should be used when work is being performed at or near an intersection.
- If construction closes the road at a T-intersection, the Contractor shall place the "CONTRACTOR NAME" (G20-6T) sign behind the Type 3 Barricades for the road closure (see BC(10) also). The "ROAD WORK NEXT X MILES" left arrow (G20-1bTL) and "ROAD WORK NEXT X MILES" right arrow (G20-1bTR) signs shall be replaced by the detour signing called for in the plans.

**TYPICAL CONSTRUCTION WARNING SIGN SIZE AND SPACING<sup>1,5,6</sup>**

Sign Number or Series	SIZE		SPACING	
	Conventional Road	Expressway/Freeway	Posted Speed MPH	Sign Δ Spacing "x" Feet (Apprx.)
CW20 <sup>4</sup>	48" x 48"	48" x 48"	30	120
CW21			35	160
CW22			40	240
CW23			45	320
CW25			50	400
CW1, CW2, CW7, CW8, CW9, CW11, CW14	36" x 36"	48" x 48"	55	500 <sup>2</sup>
CW3, CW4, CW5, CW6, CW8-3, CW10, CW12	48" x 48"	48" x 48"	60	600 <sup>2</sup>
			65	700 <sup>2</sup>
			70	800 <sup>2</sup>
			75	900 <sup>2</sup>
			80	1000 <sup>2</sup>
			*	* <sup>3</sup>

\* For typical sign spacings on divided highways, expressways and freeways, see Part 6 of the "Texas Manual on Uniform Traffic Control Devices" (TMUTCD) typical application diagrams or TCP Standard Sheets.

Δ Minimum distance from work area to first Advance Warning sign nearest the work area and/or distance between each additional sign.

**GENERAL NOTES**

- Special or larger size signs may be used as necessary.
- Distance between signs should be increased as required to have 1500 feet advance warning.
- Distance between signs should be increased as required to have 1/2 mile or more advance warning.
- 36" x 36" "ROAD WORK AHEAD" (CW20-1D) signs may be used on low volume crossroads at the discretion of the Engineer as per TMUTCD Part 5. See Note 2 under "Typical Location of Crossroad Signs".
- Only diamond shaped warning sign sizes are indicated.
- See sign size listing in "TMUTCD", Sign Appendix or the "Standard Highway Sign Designs for Texas" manual for complete list of available sign design sizes.

**WORK AREAS IN MULTIPLE LOCATIONS WITHIN CSJ LIMITS**

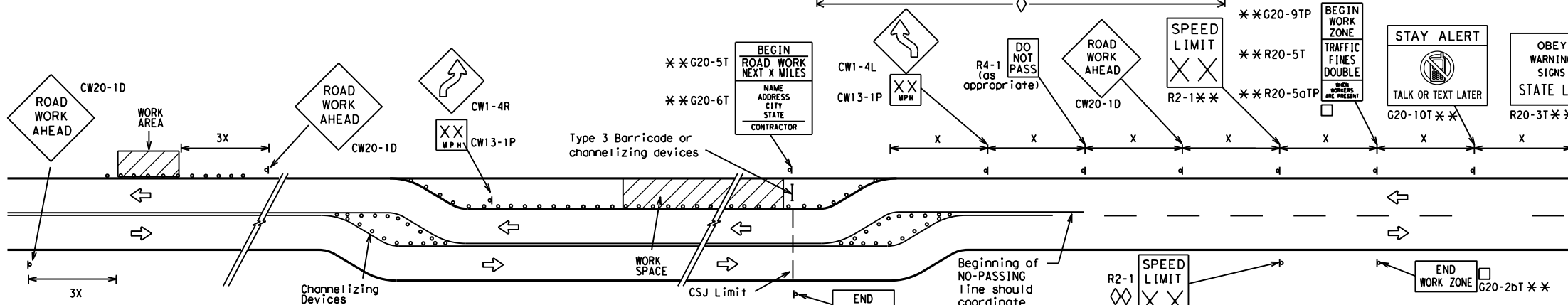

When extended distances occur between minimal work spaces, the Engineer/Inspector should ensure additional "ROAD WORK AHEAD" (CW20-1D) signs are placed in advance of these work areas to remind drivers they are still within the project limits. See the applicable TCP sheets for exact location and spacing of signs and channelizing devices.

**SAMPLE LAYOUT OF SIGNING FOR WORK BEGINNING DOWNSTREAM OF THE CSJ LIMITS**

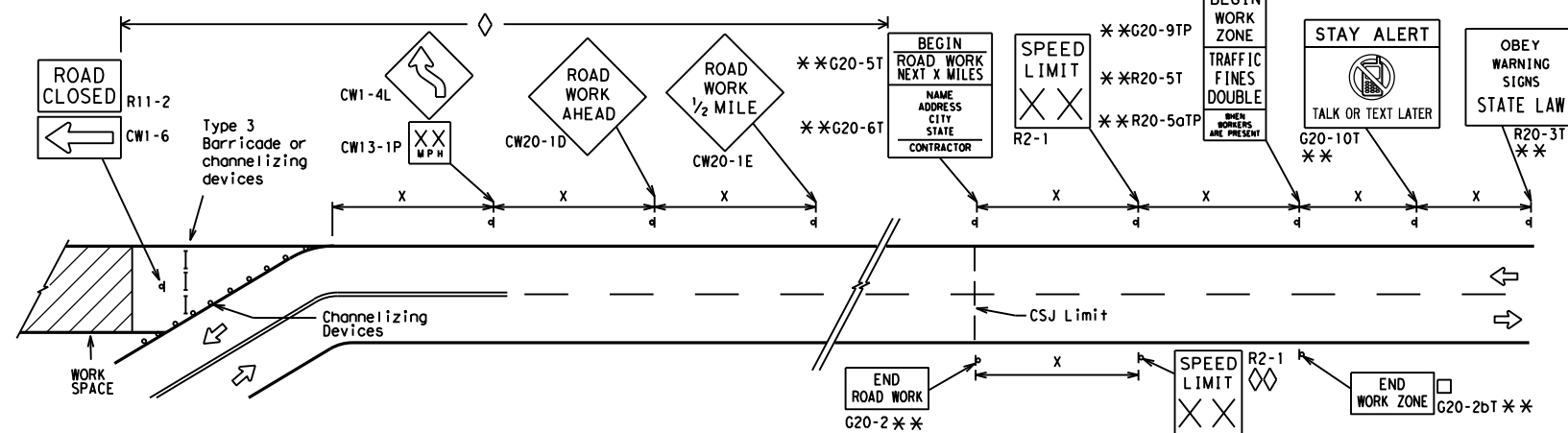

**NOTES**

The Contractor shall determine the appropriate distance to be placed on the G20-1 series signs and "BEGIN ROAD WORK NEXT X MILES" (G20-5T) sign for each specific project. This distance shall replace the "x" and shall be rounded to the nearest whole mile with the approval of the Engineer. No decimals shall be used.

- The "BEGIN WORK ZONE" (G20-9TP) and "END WORK ZONE" (G20-2bT) shall be used as shown on the sample layout when advance signs are required outside the CSJ Limits. They inform the motorist of entering or leaving a part of the work zone lying outside the CSJ Limits where traffic fines may double if workers are present.
- CSJ limit signing is required for highway construction and maintenance work, with the exception of mobile operations.
- Area for placement of "ROAD WORK AHEAD" (CW20-1D) sign and other signs or devices as called for on the Traffic Control Plan.
- Contractor will install a regulatory speed limit sign at the end of the work zone.

LEGEND	
—	Type 3 Barricade
○ ○ ○	Channelizing Devices
■	Sign
X	See Typical Construction Warning Sign Size and Spacing chart or the TMUTCD for sign spacing requirements.

SHEET 2 OF 12

Texas Department of Transportation  
 Traffic Safety Division Standard

**BARRICADE AND CONSTRUCTION PROJECT LIMIT**

**BC(2)-21**

FILE: bc-21.dgn	DN: TxDOT	CK: TxDOT	DW: TxDOT	CK: TxDOT
© TxDOT November 2002	CONT	SECT	JOB	HIGHWAY
REVISIONS	091800		392	VA
9-07 8-14	DIST	COUNTY		SHEET NO.
7-13 5-21	DAL	DALLAS, ETC.		9

DATE: FILE:

# TYPICAL APPLICATION OF WORK ZONE SPEED LIMIT SIGNS

Work zone speed limits shall be regulatory, established in accordance with the "Procedures for Establishing Speed Zones," and approved by the Texas Transportation Commission, or by City Ordinance when within Incorporated City Limits.

Reduced speeds should only be posted in the vicinity of work activity and not throughout the entire project. Regulatory work zone speed signs (R2-1) shall be removed or covered during periods when they are not needed.



## GUIDANCE FOR USE:

### LONG/INTERMEDIATE TERM WORK ZONE SPEED LIMITS

This type of work zone speed limit should be included on the design of the traffic control plans when restricted geometrics with a lower design speed are present in the work zone and modification of the geometrics to a higher design speed is not feasible.

Long/Intermediate Term Work Zone Speed Limit signs, when approved as described above, should be posted and visible to the motorist when work activity is present. Work activity may also be defined as a change in the roadway that requires a reduced speed for motorists to safely negotiate the work area, including:

- rough road or damaged pavement surface
- substantial alteration of roadway geometrics (diversions)
- construction detours
- grade
- width
- other conditions readily apparent to the driver

As long as any of these conditions exist, the work zone speed limit signs should remain in place.

### SHORT TERM WORK ZONE SPEED LIMITS

This type of work zone speed limit may be included on the design of the traffic control plans when workers or equipment are not behind concrete barrier, when work activity is within 10 feet of the traveled way or actually in the traveled way.

Short Term Work Zone Speed Limit signs should be posted and visible to the motorists only when work activity is present. When work activity is not present, signs shall be removed or covered. (See Removing or Covering on BC(4)).

## GENERAL NOTES

- Regulatory work zone speed limits should be used only for sections of construction projects where speed control is of major importance.
- Regulatory work zone speed limit signs shall be placed on supports at a 7 foot minimum mounting height.
- Speed zone signs are illustrated for one direction of travel and are normally posted for each direction of travel.
- Frequency of work zone speed limit signs should be:
 

40 mph and greater	0.2 to 2 miles
35 mph and less	0.2 to 1 mile
- Regulatory speed limit signs shall have black legend and border on a white reflective background (See "Reflective Sheeting" on BC(4)).
- Fabrication, erection and maintenance of the "ADVANCE SPEED LIMIT" (CW3-5) sign, "WORK ZONE" (G20-5aP) plaque and the "SPEED LIMIT" (R2-1) signs shall not be paid for directly, but shall be considered subsidiary to Item 502.
- Turning signs from view, laying signs over or down will not be allowed, unless as otherwise noted under "REMOVING OR COVERING" on BC(4).
- Techniques that may help reduce traffic speeds include but are not limited to:
  - Law enforcement.
  - Flagger stationed next to sign.
  - Portable changeable message sign (PCMS).
  - Low-power (drone) radar transmitter.
  - Speed monitor trailers or signs.
- Speeds shown on details above are for illustration only. Work Zone Speed Limits should only be posted as approved for each project.
- For more specific guidance concerning the type of work, work zone conditions and factors impacting allowable regulatory construction speed zone reduction see TxDOT form #1204 in the TxDOT e-form system.

DISCLAIMER: The use of this standard is governed by the "Texas Engineering Practice Act". No warranty of any kind is made by TxDOT for any purpose whatsoever. TxDOT assumes no responsibility for the conversion of this standard to other formats or for incorrect results or damages resulting from its use.

DATE:  
FILE:

SHEET 3 OF 12



## BARRICADE AND CONSTRUCTION WORK ZONE SPEED LIMIT

BC (3) - 21

FILE:	bc-21.dgn	DW:	TxDOT	CK:	TxDOT	DW:	TxDOT	CK:	TxDOT
© TxDOT	November 2002	CONT	SECT	JOB	HIGHWAY				
REVISIONS		0918	00	392	VA				
9-07	8-14	DIST	COUNTY	SHEET NO.					
7-13	5-21	DAL	DALLAS, ETC.	10					

DISCLAIMER: The use of this standard is governed by the "Texas Engineering Practice Act". No warranty of any kind is made by TxDOT for any purpose whatsoever. TxDOT assumes no responsibility for the conversion of this standard to other formats or for incorrect results or damages resulting from its use.

**TYPICAL MINIMUM CLEARANCES FOR LONG TERM AND INTERMEDIATE TERM SIGNS**

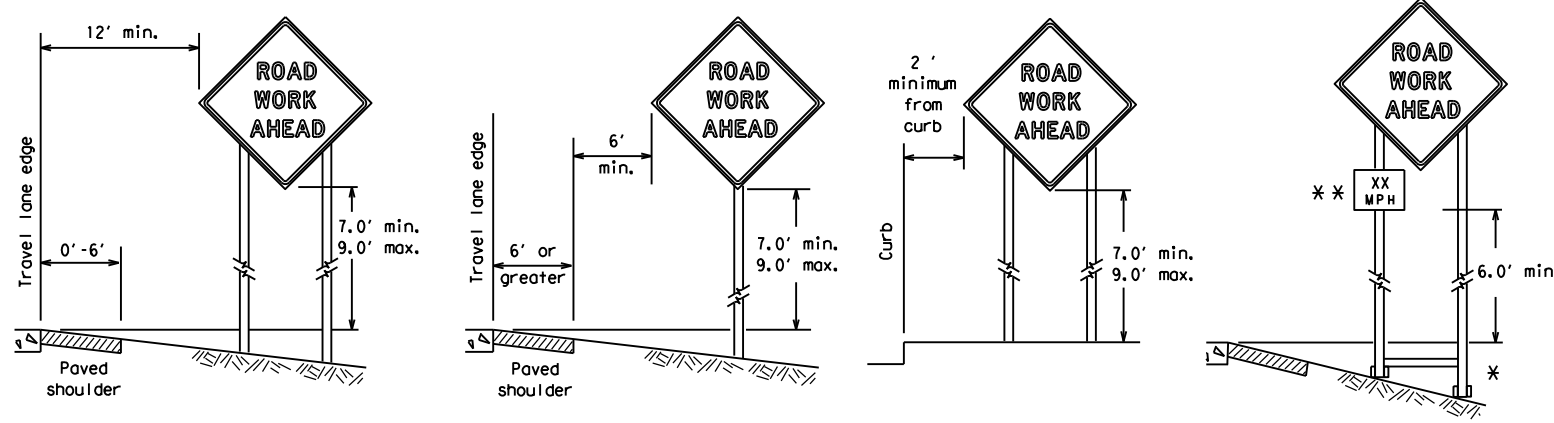

\* When placing skid supports on unlevel ground, the leg post lengths must be adjusted so the sign appears straight and plumb. Objects shall NOT be placed under skids as a means of leveling.

\*\* When plaques are placed on dual-leg supports, they should be attached to the upright nearest the travel lane. Supplemental plaques (advisory or distance) should not cover the surface of the parent sign.

**ATTACHMENT FOR SIGN SUPPORTS**

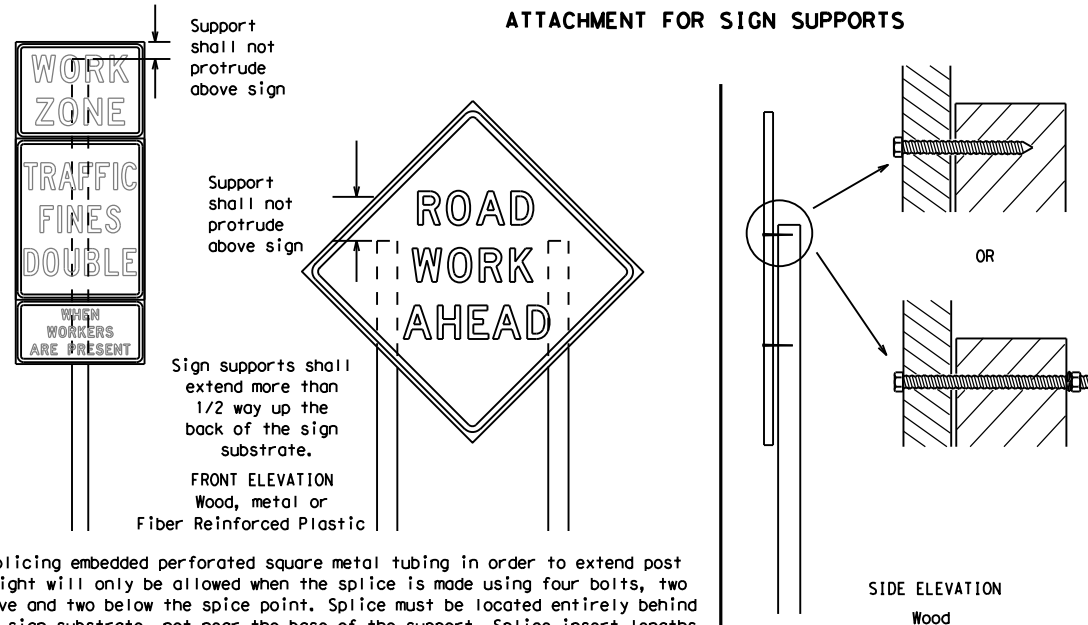

Nails shall NOT be allowed. Each sign shall be attached directly to the sign support. Multiple signs shall not be joined or spliced by any means. Wood supports shall not be extended or repaired by splicing or other means.

Splicing embedded perforated square metal tubing in order to extend post height will only be allowed when the splice is made using four bolts, two above and two below the splice point. Splice must be located entirely behind the sign substrate, not near the base of the support. Splice insert lengths should be at least 5 times nominal post size, centered on the splice and of at least the same gauge material.

**STOP/SLOW PADDLES**

1. STOP/SLOW paddles are the primary method to control traffic by flaggers. The STOP/SLOW paddle size should be 24" x 24".
2. STOP/SLOW paddles shall be retroreflectORIZED when used at night.
3. STOP/SLOW paddles may be attached to a staff with a minimum length of 6' to the bottom of the sign.
4. Any lights incorporated into the STOP or SLOW paddle faces shall only be as specifically described in Section 6E.03 Hand Signaling Devices in the TMUTCD.

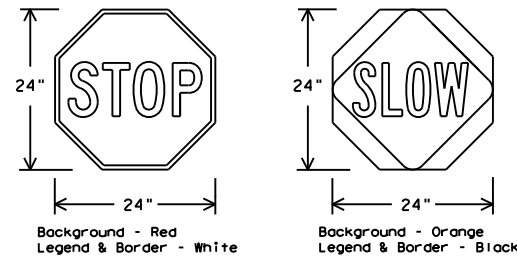

SHEETING REQUIREMENTS (WHEN USED AT NIGHT)		
USAGE	COLOR	SIGN FACE MATERIAL
BACKGROUND	RED	TYPE B OR C SHEETING
BACKGROUND	ORANGE	TYPE B <sub>FL</sub> OR C <sub>FL</sub> SHEETING
LEGEND & BORDER	WHITE	TYPE B OR C SHEETING
LEGEND & BORDER	BLACK	ACRYLIC NON-REFLECTIVE FILM

**CONTRACTOR REQUIREMENTS FOR MAINTAINING PERMANENT SIGNS WITHIN THE PROJECT LIMITS**

1. Permanent signs are used to give notice of traffic laws or regulations, call attention to conditions that are potentially hazardous to traffic operations, show route designations, destinations, directions, distances, services, points of interest, and other geographical, recreational, specific service (LOGO), or cultural information. Drivers proceeding through a work zone need the same, if not better route guidance as normally installed on a roadway without construction.
2. When permanent regulatory or warning signs conflict with work zone conditions, remove or cover the permanent signs until the permanent sign message matches the roadway condition. For details for covering large guide signs see the TS-CD standard.
3. When existing permanent signs are moved and relocated due to construction purposes, they shall be visible to motorists at all times.
4. If existing signs are to be relocated on their original supports, they shall be installed on crashworthy bases as shown on the SMD Standard sheets. The signs shall meet the required mounting heights shown on the BC Sheets or the SMD Standards. This work should be paid for under the appropriate pay item for relocating existing signs.
5. If permanent signs are to be removed and relocated using temporary supports, the Contractor shall use crashworthy supports as shown on the BC standard sheets, TLRs standard sheets or the CWZTC list. The signs shall meet the required mounting heights shown on the BC, or the SMD standard sheets during construction. This work should be paid for under the appropriate pay item for relocating existing signs.
6. Any sign or traffic control device that is struck or damaged by the Contractor or his/her construction equipment shall be replaced as soon as possible by the Contractor to ensure proper guidance for the motorists. This will be subsidiary to Item 502.

**GENERAL NOTES FOR WORK ZONE SIGNS**

1. Contractor shall install and maintain signs in a straight and plumb condition and/or as directed by the Engineer.
2. Wooden sign posts shall be painted white.
3. Barricades shall NOT be used as sign supports.
4. All signs shall be installed in accordance with the plans or as directed by the Engineer. Signs shall be used to regulate, warn, and guide the traveling public safely through the work zone.
5. The Contractor may furnish either the sign design shown in the plans or in the "Standard Highway Sign Designs for Texas" (SHSD). The Engineer/Inspector may require the Contractor to furnish other work zone signs that are shown in the TMUTCD but may have been omitted from the plans. Any variation in the plans shall be documented by written agreement between the Engineer and the Contractor's Responsible Person. All changes must be documented in writing before being implemented. This can include documenting the changes in the Inspector's TxDOT diary and having both the Inspector and Contractor initial and date the agreed upon changes.
6. The Contractor shall furnish sign supports listed in the "Compliant Work Zone Traffic Control Device List" (CWZTC) for small roadside signs. Supports for temporary large roadside signs shall meet the requirements detailed on the Temporary Large Roadside Signs (TLRS) standard sheets. The Contractor shall install the sign support in accordance with the manufacturer's recommendations. If there is a question regarding installation procedures, the Contractor shall furnish the Engineer a copy of the manufacturer's installation recommendations so the Engineer can verify the correct procedures are being followed.
7. The Contractor is responsible for installing signs on approved supports and replacing signs with damaged or cracked substrates and/or damaged or marred reflective sheeting as directed by the Engineer/Inspector.
8. Identification markings may be shown only on the back of the sign substrate. The maximum height of letters and/or company logos used for identification shall be 1 inch.
9. The Contractor shall replace damaged wood posts. New or damaged wood sign posts shall not be spliced.

**DURATION OF WORK (as defined by the "Texas Manual on Uniform Traffic Control Devices" Part 6)**

1. The types of sign supports, sign mounting height, the size of signs, and the type of sign substrates can vary based on the type of work being performed. The Engineer is responsible for selecting the appropriate size sign for the type of work being performed. The Contractor is responsible for ensuring the sign support, sign mounting height and substrate meets manufacturer's recommendations in regard to crashworthiness and duration of work requirements.
  - a. Long-term stationary - work that occupies a location more than 3 days.
  - b. Intermediate-term stationary - work that occupies a location more than one daylight period up to 3 days, or nighttime work lasting more than one hour.
  - c. Short-term stationary - daytime work that occupies a location for more than 1 hour in a single daylight period.
  - d. Short, duration - work that occupies a location up to 1 hour.
  - e. Mobile - work that moves continuously or intermittently (stopping for up to approximately 15 minutes.)

**SIGN MOUNTING HEIGHT**

1. The bottom of Long-term/Intermediate-term signs shall be at least 7 feet, but not more than 9 feet, above the paved surface, except as shown for supplemental plaques mounted below other signs.
2. The bottom of Short-term/Short Duration signs shall be a minimum of 1 foot above the pavement surface but no more than 2 feet above the ground.
3. Long-term/Intermediate-term Signs may be used in lieu of Short-term/Short Duration signing.
4. Short-term/Short Duration signs shall be used only during daylight and shall be removed at the end of the workday or raised to appropriate Long-term/Intermediate sign height.
5. Regulatory signs shall be mounted at least 7 feet, but not more than 9 feet, above the paved surface regardless of work duration.

**SIZE OF SIGNS**

1. The Contractor shall furnish the sign sizes shown on BC (2) unless otherwise shown in the plans or as directed by the Engineer.

**SIGN SUBSTRATES**

1. The Contractor shall ensure the sign substrate is installed in accordance with the manufacturer's recommendations for the type of sign support that is being used. The CWZTC lists each substrate that can be used on the different types and models of sign supports.
2. "Mesh" type materials are NOT an approved sign substrate, regardless of the tightness of the weave.
3. All wooden individual sign panels fabricated from 2 or more pieces shall have one or more plywood cleat, 1/2" thick by 6" wide, fastened to the back of the sign and extending fully across the sign. The cleat shall be attached to the back of the sign using wood screws that do not penetrate the face of the sign panel. The screws shall be placed on both sides of the splice and spaced at 6" centers. The Engineer may approve other methods of splicing the sign face.

**REFLECTIVE SHEETING**

1. All signs shall be retroreflective and constructed of sheeting meeting the color and retro-reflectivity requirements of DMS-8300 for rigid signs or DMS-8310 for roll-up signs. The web address for DMS specifications is shown on BC(1).
2. White sheeting, meeting the requirements of DMS-8300 Type A, shall be used for signs with a white background.
3. Orange sheeting, meeting the requirements of DMS-8300 Type B<sub>FL</sub> or Type C<sub>FL</sub>, shall be used for rigid signs with orange backgrounds.

**SIGN LETTERS**

1. All sign letters and numbers shall be clear, and open rounded type uppercase alphabet letters as approved by the Federal Highway Administration (FHWA) and as published in the "Standard Highway Sign Design for Texas" manual. Signs, letters and numbers shall be of first class workmanship in accordance with Department Standards and Specifications.

**REMOVING OR COVERING**

1. When sign messages may be confusing or do not apply, the signs shall be removed or completely covered.
2. Long-term stationary or intermediate stationary signs installed on square metal tubing may be turned away from traffic 90 degrees when the sign message is not applicable. This technique may not be used for signs installed in the median of divided highways or near any intersections where the sign may be seen from approaching traffic.
3. Signs installed on wooden skids shall not be turned at 90 degree angles to the roadway. These signs should be removed or completely covered when not required.
4. When signs are covered, the material used shall be opaque, such as heavy mil black plastic, or other materials which will cover the entire sign face and maintain their opaque properties under automobile headlights at night, without damaging the sign sheeting.
5. Burlap shall NOT be used to cover signs.
6. Duct tape or other adhesive material shall NOT be affixed to a sign face.
7. Signs and anchor stubs shall be removed and holes backfilled upon completion of work.

**SIGN SUPPORT WEIGHTS**

1. Where sign supports require the use of weights to keep from turning over, the use of sandbags with dry, cohesionless sand should be used.
2. The sandbags will be tied shut to keep the sand from spilling and to maintain a constant weight.
3. Rock, concrete, iron, steel or other solid objects shall not be permitted for use as sign support weights.
4. Sandbags should weigh a minimum of 35 lbs and a maximum of 50 lbs.
5. Sandbags shall be made of a durable material that tears upon vehicular impact. Rubber (such as tire inner tubes) shall NOT be used.
6. Rubber ballasts designed for channelizing devices should not be used for ballast on portable sign supports. Sign supports designed and manufactured with rubber bases may be used when shown on the CWZTC list.
7. Sandbags shall only be placed along or laid over the base supports of the traffic control device and shall not be suspended above ground level or hung with rope, wire, chains or other fasteners. Sandbags shall be placed along the length of the skids to weigh down the sign support.
8. Sandbags shall NOT be placed under the skid and shall not be used to level sign supports placed on slopes.

**FLAGS ON SIGNS**

1. Flags may be used to draw attention to warning signs. When used, the flag shall be 16 inches square or larger and shall be orange or fluorescent red-orange in color. Flags shall not be allowed to cover any portion of the sign face.

SHEET 4 OF 12



**BARRICADE AND CONSTRUCTION TEMPORARY SIGN NOTES**

**BC (4) - 21**

FILE: bc-21.dgn	DN: TxDOT	CR: TxDOT	OW: TxDOT	CK: TxDOT
© TxDOT November 2002	CONT	SECT	JOB	HIGHWAY
REVISIONS	0918	00	392	VA
9-07 8-14	DIST	COUNTY	SHEET NO.	
7-13 5-21	DAL	DALLAS, ETC.	11	

DATE: FILE:

DISCLAIMER: The use of this standard is governed by the "Texas Engineering Practice Act". No warranty of any kind is made by TxDOT for any purpose whatsoever. TxDOT assumes no responsibility for the conversion of this standard to other formats or for incorrect results or damages resulting from its use.

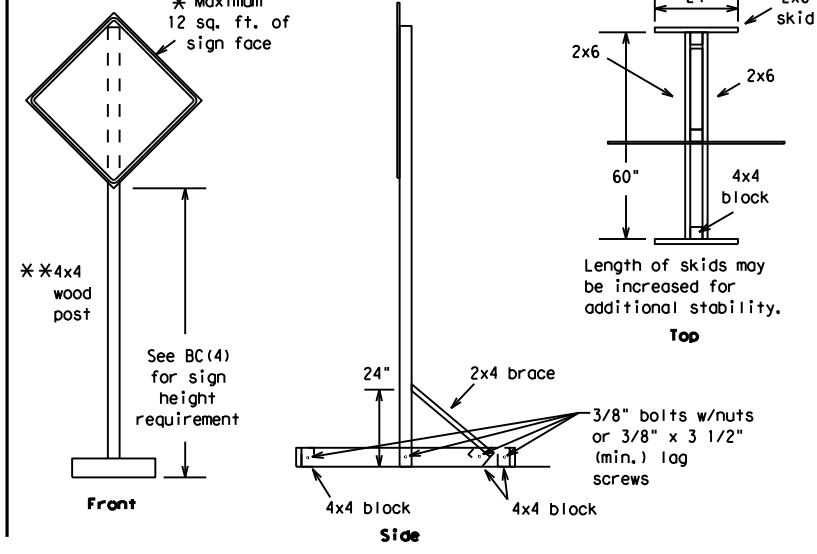
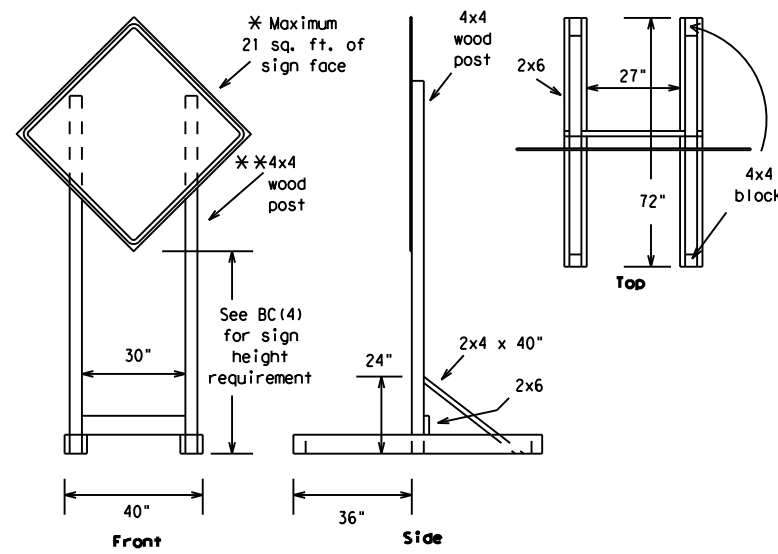

### SKID MOUNTED WOOD SIGN SUPPORTS

\* LONG/INTERMEDIATE TERM STATIONARY - PORTABLE SKID MOUNTED SIGN SUPPORTS

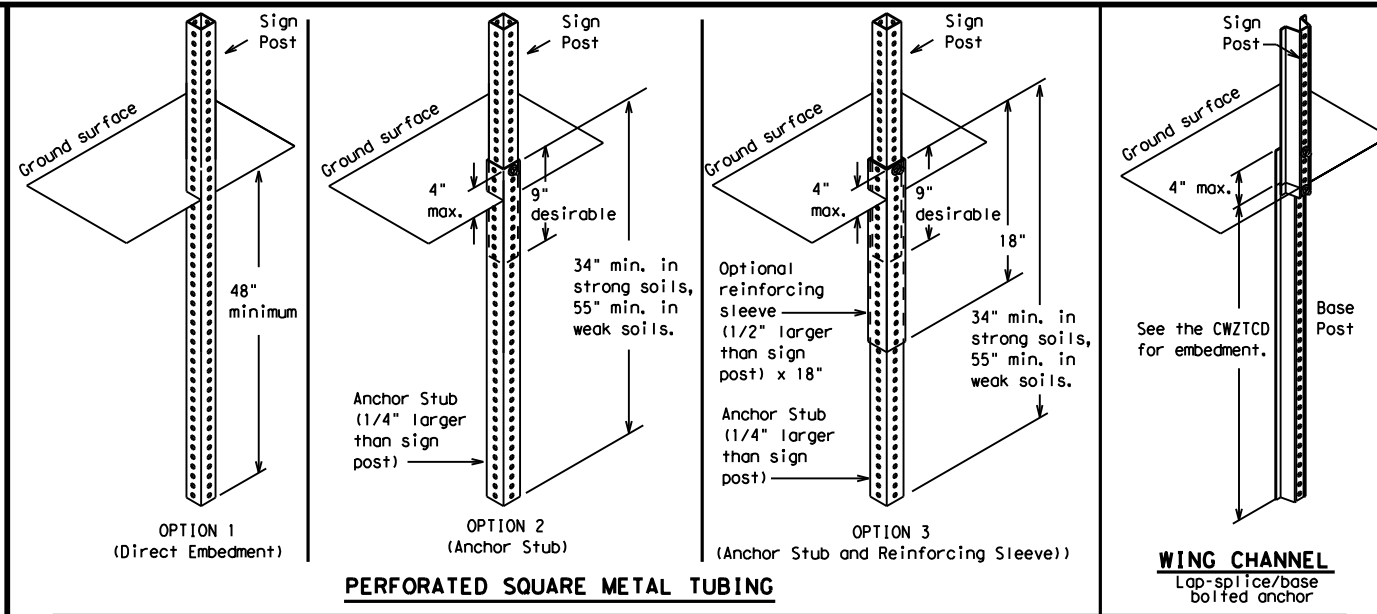

### GROUND MOUNTED SIGN SUPPORTS

Refer to the CWZTCD and the manufacturer's installation procedure for each type sign support. The maximum sign square footage shall adhere to the manufacturer's recommendation. Two post installations can be used for larger signs.

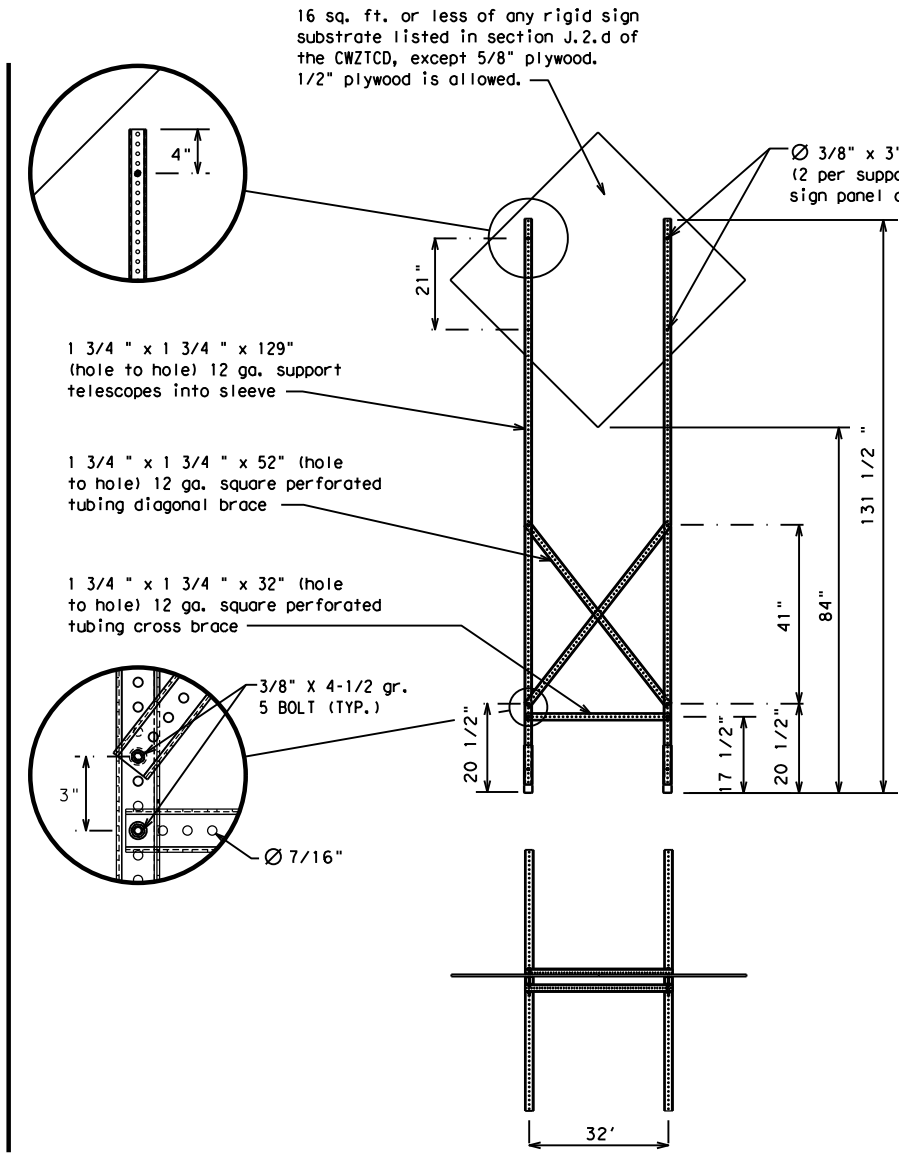
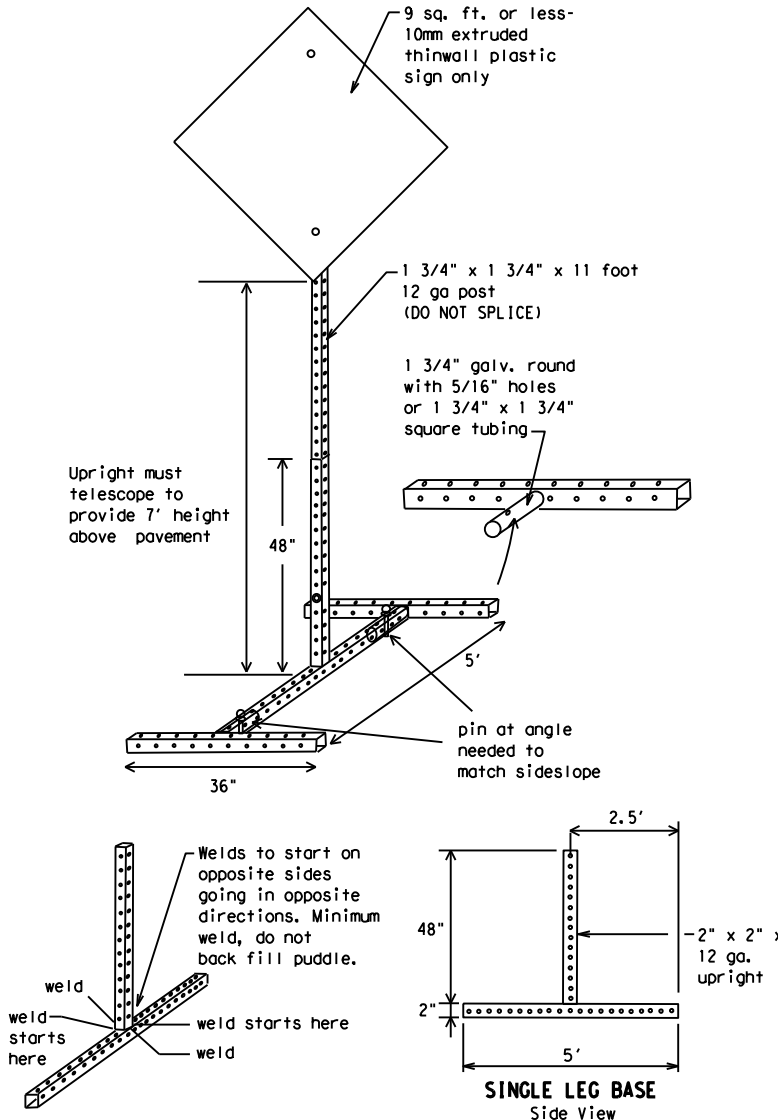

### SKID MOUNTED PERFORATED SQUARE STEEL TUBING SIGN SUPPORTS

\* LONG/INTERMEDIATE TERM STATIONARY - PORTABLE SKID MOUNTED SIGN SUPPORTS

### WEDGE ANCHORS

Both steel and plastic Wedge Anchor Systems as shown on the SMD Standard Sheets may be used as temporary sign supports for signs up to 10 square feet of sign face. They may be set in concrete or in sturdy soils if approved by the Engineer. (See web address for "Traffic Engineering Standard Sheets" on BC(1)).

### OTHER DESIGNS

MORE DETAILS OF APPROVED LONG/INTERMEDIATE AND SHORT TERM SUPPORTS CAN BE FOUND ON THE CWZTCD LIST. SEE BC(1) FOR WEBSITE LOCATION.

### GENERAL NOTES

- Nails may be used in the assembly of wooden sign supports, but 3/8" bolts with nuts or 3/8" x 3 1/2" lag screws must be used on every joint for final connection.
- No more than 2 sign posts shall be placed within a 7 ft. circle, except for specific materials noted on the CWZTCD List.
- When project is completed, all sign supports and foundations shall be removed from the project site. This will be considered subsidiary to Item 502.

- \* See BC(4) for definition of "Work Duration."
- \*\* Wood sign posts MUST be one piece. Splicing will NOT be allowed. Posts shall be painted white.
- See the CWZTCD for the type of sign substrate that can be used for each approved sign support.

SHEET 5 OF 12



## BARRICADE AND CONSTRUCTION TYPICAL SIGN SUPPORT

BC(5) - 21

FILE:	bc-21.dgn	DN:	TxDOT	CK:	TxDOT	OW:	TxDOT	CR:	TxDOT
© TxDOT	November 2002	CONT	SECT	JOB	HIGHWAY				
REVISIONS		0918	00	392	VA				
9-07	8-14	DIST	COUNTY	SHEET NO.					
7-13	5-21	DAL	DALLAS, ETC.	12					

DATE:  
FILE:

WHEN NOT IN USE, REMOVE THE PCMS FROM THE RIGHT-OF-WAY OR PLACE THE PCMS BEHIND BARRIER OR GUARDRAIL WITH SIGN PANEL TURNED PARALLEL TO TRAFFIC

# RECOMMENDED PHASES AND FORMATS FOR PCMS MESSAGES DURING ROADWORK ACTIVITIES

(The Engineer may approve other messages not specifically covered here.)

## PORTABLE CHANGEABLE MESSAGE SIGNS

- The Engineer/Inspector shall approve all messages used on portable changeable message signs (PCMS).
- Messages on PCMS should contain no more than 8 words (about four to eight characters per word), not including simple words such as "TO," "FOR," "AT," etc.
- Messages should consist of a single phase, or two phases that alternate. Three-phase messages are not allowed. Each phase of the message should convey a single thought, and must be understood by itself.
- Use the word "EXIT" to refer to an exit ramp on a freeway; i.e., "EXIT CLOSED." Do not use the term "RAMP."
- Always use the route or interstate designation (IH, US, SH, FM) along with the number when referring to a roadway.
- When in use, the bottom of a stationary PCMS message panel should be a minimum 7 feet above the roadway, where possible.
- The message term "WEEKEND" should be used only if the work is to start on Saturday morning and end by Sunday evening at midnight. Actual days and hours of work should be displayed on the PCMS if work is to begin on Friday evening and/or continue into Monday morning.
- The Engineer/Inspector may select one of two options which are available for displaying a two-phase message on a PCMS. Each phase may be displayed for either four seconds each or for three seconds each.
- Do not "flash" messages or words included in a message. The message should be steady burn or continuous while displayed.
- Do not present redundant information on a two-phase message; i.e., keeping two lines of the message the same and changing the third line.
- Do not use the word "Danger" in message.
- Do not display the message "LANES SHIFT LEFT" or "LANES SHIFT RIGHT" on a PCMS. Drivers do not understand the message.
- Do not display messages that scroll horizontally or vertically across the face of the sign.
- The following table lists abbreviated words and two-word phrases that are acceptable for use on a PCMS. Both words in a phrase must be displayed together. Words or phrases not on this list should not be abbreviated, unless shown in the TMUTCD.
- PCMS character height should be at least 18 inches for trailer mounted units. They should be visible from at least 1/2 (.5) mile and the text should be legible from at least 600 feet at night and 800 feet in daylight. Truck mounted units must have a character height of 10 inches and must be legible from at least 400 feet.
- Each line of text should be centered on the message board rather than left or right justified.
- If disabled, the PCMS should default to an illegible display that will not alarm motorists and will only be used to alert workers that the PCMS has malfunctioned. A pattern such as a series of horizontal solid bars is appropriate.

## Phase 1: Condition Lists

### Road/Lane/Ramp Closure List

FREEWAY CLOSED X MILE	FRONTAGE ROAD CLOSED
ROAD CLOSED AT SH XXX	SHOULDER CLOSED XXX FT
ROAD CLSD AT FM XXXX	RIGHT LN CLOSED XXX FT
RIGHT X LANES CLOSED	RIGHT X LANES OPEN
CENTER LANE CLOSED	DAYTIME LANE CLOSURES
NIGHT LANE CLOSURES	I-XX SOUTH EXIT CLOSED
VARIOUS LANES CLOSED	EXIT XXX CLOSED X MILE
EXIT CLOSED	RIGHT LN TO BE CLOSED
MALL DRIVEWAY CLOSED	X LANES CLOSED TUE - FRI
XXXXXXXX BLVD CLOSED	

### Other Condition List

ROADWORK XXX FT	ROAD REPAIRS XXXX FT
FLAGGER XXXX FT	LANE NARROWS XXXX FT
RIGHT LN NARROWS XXXX FT	TWO-WAY TRAFFIC XX MILE
MERGING TRAFFIC XXXX FT	CONST TRAFFIC XXX FT
LOOSE GRAVEL XXXX FT	UNEVEN LANES XXXX FT
DETOUR X MILE	ROUGH ROAD XXXX FT
ROADWORK PAST SH XXXX	ROADWORK NEXT FRI-SUN
BUMP XXXX FT	US XXX EXIT X MILES
TRAFFIC SIGNAL XXXX FT	LANES SHIFT *

\* LANES SHIFT in Phase 1 must be used with STAY IN LANE in Phase 2.

## Phase 2: Possible Component Lists

### Action to Take/Effect on Travel List

MERGE RIGHT	FORM X LINES RIGHT
DETOUR NEXT X EXITS	USE XXXXX RD EXIT
USE EXIT XXX	USE EXIT I-XX NORTH
STAY ON US XXX SOUTH	USE I-XX E TO I-XX N
TRUCKS USE US XXX N	WATCH FOR TRUCKS
WATCH FOR TRUCKS	EXPECT DELAYS
EXPECT DELAYS	PREPARE TO STOP
REDUCE SPEED XXX FT	END SHOULDER USE
USE OTHER ROUTES	WATCH FOR WORKERS
STAY IN LANE *	

### Location List

AT FM XXXX
BEFORE RAILROAD CROSSING
NEXT X MILES
PAST US XXX EXIT
XXXXXXXX TO XXXXXX
US XXX TO FM XXXX

### Warning List

SPEED LIMIT XX MPH
MAXIMUM SPEED XX MPH
MINIMUM SPEED XX MPH
ADVISORY SPEED XX MPH
RIGHT LANE EXIT
USE CAUTION
DRIVE SAFELY
DRIVE WITH CARE

### \*\* Advance Notice List

TUE-FRI XX AM-X PM
APR XX-XX X PM-X AM
BEGINS MONDAY
BEGINS MAY XX
MAY X-X XX PM - XX AM
NEXT FRI-SUN
XX AM TO XX PM
NEXT TUE AUG XX
TONIGHT XX PM-XX AM

\*\* See Application Guidelines Note 6.

## APPLICATION GUIDELINES

- Only 1 or 2 phases are to be used on a PCMS.
- The 1st phase (or both) should be selected from the "Road/Lane/Ramp Closure List" and the "Other Condition List".
- A 2nd phase can be selected from the "Action to Take/Effect on Travel, Location, General Warning, or Advance Notice Phase Lists".
- A Location Phase is necessary only if a distance or location is not included in the first phase selected.
- If two PCMS are used in sequence, they must be separated by a minimum of 1000 ft. Each PCMS shall be limited to two phases, and should be understandable by themselves.
- For advance notice, when the current date is within seven days of the actual work date, calendar days should be replaced with days of the week. Advance notification should typically be for no more than one week prior to the work.

## WORDING ALTERNATIVES

- The words RIGHT, LEFT and ALL can be interchanged as appropriate.
- Roadway designations IH, US, SH, FM and LP can be interchanged as appropriate.
- EAST, WEST, NORTH and SOUTH (or abbreviations E, W, N and S) can be interchanged as appropriate.
- Highway names and numbers replaced as appropriate.
- ROAD, HIGHWAY and FREEWAY can be interchanged as needed.
- AHEAD may be used instead of distances if necessary.
- FT and MI, MILE and MILES interchanged as appropriate.
- AT, BEFORE and PAST interchanged as needed.
- Distances or AHEAD can be eliminated from the message if a location phase is used.

PCMS SIGNS WITHIN THE R.O.W. SHALL BE BEHIND GUARDRAIL OR CONCRETE BARRIER OR SHALL HAVE A MINIMUM OF FOUR (4) PLASTIC DRUMS PLACED PERPENDICULAR TO TRAFFIC ON THE UPSTREAM SIDE OF THE PCMS, WHEN EXPOSED TO ONE DIRECTION OF TRAFFIC. WHEN EXPOSED TO TWO WAY TRAFFIC, THE FOUR DRUMS SHOULD BE PLACED WITH ONE DRUM AT EACH OF THE FOUR CORNERS OF THE UNIT.

## FULL MATRIX PCMS SIGNS

- When Full Matrix PCMS signs are used, the character height and legibility/visibility requirements shall be maintained as listed in Note 15 under "PORTABLE CHANGEABLE MESSAGE SIGNS" above.
- When symbol signs, such as the "Flagger Symbol" (CW20-7) are represented graphically on the Full Matrix PCMS sign and, with the approval of the Engineer, it shall maintain the legibility/visibility requirement listed above.
- When symbol signs are represented graphically on the Full Matrix PCMS, they shall only supplement the use of the static sign represented, and shall not substitute for, or replace that sign.
- A full matrix PCMS may be used to simulate a flashing arrow board provided it meets the visibility, flash rate and dimming requirements on BC(7), for the same size arrow.

DISCLAIMER: The use of this standard is governed by the "Texas Engineering Practice Act". No warranty of any kind is made by TxDOT for any purpose whatsoever. TxDOT assumes no responsibility for the conversion of this standard to other formats or for incorrect results or damages resulting from its use.

WORD OR PHRASE	ABBREVIATION	WORD OR PHRASE	ABBREVIATION
Access Road	ACCS RD	Major	MAJ
Alternate	ALT	Miles	MI
Avenue	AVE	Miles Per Hour	MPH
Best Route	BEST RTE	Minor	MNR
Boulevard	BLVD	Monday	MON
Bridge	BRDG	Normal	NORM
Canal	CANT	North	N
Center	CTR	Northbound	(route) N
Construction Ahead	CONST AHD	Parking	PKING
CROSSING	XING	Road	RD
Detour Route	DETOUR RTE	Right Lane	RT LN
Do Not	DONT	Saturday	SAT
East	E	Service Road	SERV RD
Eastbound	(route) E	Shoulder	SHLDR
Emergency	EMER	Slippery	SLIP
Emergency Vehicle	EMER VEH	South	S
Entrance, Enter	ENT	Southbound	(route) S
Express Lane	EXP LN	Speed	SPD
Expressway	EXPWY	Street	ST
XXXX Feet	XXXX FT	Sunday	SUN
Fog Ahead	FOG AHD	Telephone	PHONE
Freeway	FRWY, FWY	Temporary	TEMP
Freeway Blocked	FWY BLKD	Thursday	THURS
Friday	FRI	To Downtown	TO DWNTN
Hazardous Driving	HAZ DRIVING	Traffic	TRAF
Hazardous Material	HAZMAT	Travelers	TRVLR
High-Occupancy Vehicle	HOV	Tuesday	TUES
Highway	HWY	Time Minutes	TIME MIN
Hour(s)	HR, HRS	Upper Level	UPR LEVEL
Information	INFO	Vehicles (s)	VEH, VEHS
It Is	ITS	Warning	WARN
Junction	JCT	Wednesday	WED
Left	LFT	Weight Limit	WT LIMIT
Left Lane	LFT LN	West	W
Lane Closed	LN CLOSED	Westbound	(route) W
Lower Level	LWR LEVEL	Wet Pavement	WET PVMT
Maintenance	MAINT	Will Not	WONT

Roadway designation # IH-number, US-number, SH-number, FM-number

DATE: FILE:

SHEET 6 OF 12



## BARRICADE AND CONSTRUCTION PORTABLE CHANGEABLE MESSAGE SIGN (PCMS)

BC (6) - 21

FILE: bc-21.dgn	DN: TxDOT	CR: TxDOT	DW: TxDOT	CK: TxDOT
© TxDOT November 2002	CONT	SECT	JOB	HIGHWAY
REVISIONS	0918	00	392	VA
9-07 8-14	DIST	COUNTY	SHEET NO.	
7-13 5-21	DAL	DALLAS, ETC.	13	

DISCLAIMER: The use of this standard is governed by the "Texas Engineering Practice Act". No warranty of any kind is made by TxDOT for any purpose whatsoever. TxDOT assumes no responsibility for the conversion of this standard to other formats or for incorrect results or damages resulting from its use.

- Barrier Reflectors shall be pre-qualified, and conform to the color and reflectivity requirements of DMS-8600. A list of prequalified Barrier Reflectors can be found at the Material Producer List web address shown on BC(1).
- Color of Barrier Reflectors shall be as specified in the TMUTCD. The cost of the reflectors shall be considered subsidiary to Item 512.

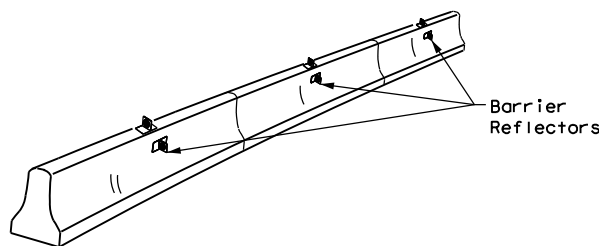

**CONCRETE TRAFFIC BARRIER (CTB)**

- Where traffic is on one side of the CTB, two (2) Barrier Reflectors shall be mounted in approximately the midsection of each section of CTB. An alternate mounting location is uniformly spaced at one end of each CTB. This will allow for attachment of a barrier grapple without damaging the reflector. The Barrier Reflector mounted on the side of the CTB shall be located directly below the reflector mounted on top of the barrier, as shown in the detail above.
- Where CTB separates two-way traffic, three barrier reflectors shall be mounted on each section of CTB. The reflector unit on top shall have two yellow reflective faces (Bi-Directional) while the reflectors on each side of the barrier shall have one yellow reflective face, as shown in the detail above.
- When CTB separates traffic traveling in the same direction, no barrier reflectors will be required on top of the CTB.
- Barrier Reflector units shall be yellow or white in color to match the edgeline being supplemented.
- Maximum spacing of Barrier Reflectors is forty (40) feet.
- Pavement markers or temporary flexible-reflective roadway marker tabs shall NOT be used as CTB delineation.
- Attachment of Barrier Reflectors to CTB shall be per manufacturer's recommendations.
- Missing or damaged Barrier Reflectors shall be replaced as directed by the Engineer.
- Single slope barriers shall be delineated as shown on the above detail.

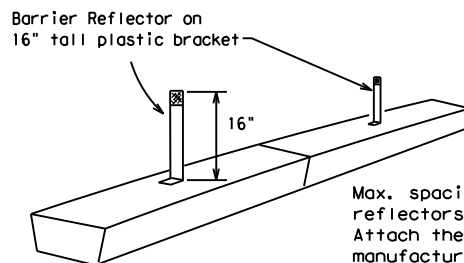

**LOW PROFILE CONCRETE BARRIER (LPCB) USED IN WORK ZONES**

LPCB is approved for use in work zone locations, where the posted speed is 45mph, or less. See Roadway Standard Sheet LPCB.

Max. spacing of barrier reflectors is 20 feet. Attach the delineators as per manufacturer's recommendations.

**LOW PROFILE CONCRETE BARRIER (LPCB)**

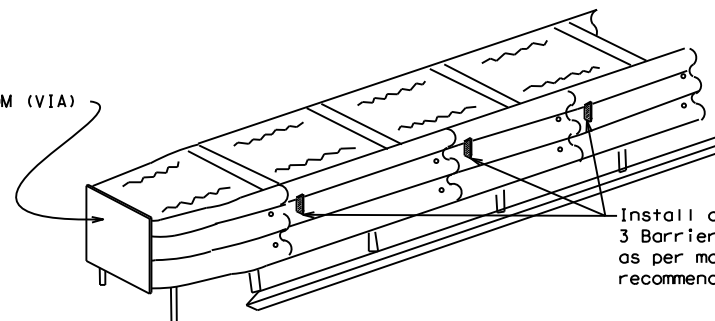

Install a minimum of 3 Barrier Reflectors as per manufacturer's recommendations.

**DELINEATION OF END TREATMENTS**

**END TREATMENTS FOR CTB'S USED IN WORK ZONES**

End treatments used on CTB's in work zones shall meet the appropriate crashworthy standards as defined in the Manual for Assessing Safety Hardware (MASH). Refer to the CWZTCD List for approved end treatments and manufacturers.

**BARRIER REFLECTORS FOR CONCRETE TRAFFIC BARRIER AND ATTENUATORS**

**WARNING LIGHTS**

- Warning lights shall meet the requirements of the TMUTCD.
- Warning lights shall NOT be installed on barricades.
- Type A-Low Intensity Flashing Warning Lights are commonly used with drums. They are intended to warn of or mark a potentially hazardous area. Their use shall be as indicated on this sheet and/or other sheets of the plans by the designation "FL". The Type A Warning Lights shall not be used with signs manufactured with Type B<sub>FL</sub> or C<sub>FL</sub> Sheeting meeting the requirements of Departmental Material Specification DMS-8300.
- Type-C and Type D 360 degree Steady Burn Lights are intended to be used in a series for delineation to supplement other traffic control devices. Their use shall be as indicated on this sheet and/or other sheets of the plans by the designation "SB".
- The Engineer/Inspector or the plans shall specify the location and type of warning lights to be installed on the traffic control devices.
- When required by the Engineer, the Contractor shall furnish a copy of the warning lights certification. The warning light manufacturer will certify the warning lights meet the requirements of the latest ITE Purchase Specifications for Flashing and Steady-Burn Warning Lights.
- When used to delineate curves, Type-C and Type D Steady Burn Lights should only be placed on the outside of the curve, not the inside.
- The location of warning lights and warning reflectors on drums shall be as shown elsewhere in the plans.

**WARNING LIGHTS MOUNTED ON PLASTIC DRUMS**

- Type A flashing warning lights are intended to warn drivers that they are approaching or are in a potentially hazardous area.
- Type A random flashing warning lights are not intended for delineation and shall not be used in a series.
- A series of sequential flashing warning lights placed on channelizing devices to form a merging taper may be used for delineation. If used, the successive flashing of the sequential warning lights should occur from the beginning of the taper to the end of the merging taper in order to identify the desired vehicle path. The rate of flashing for each light shall be 65 flashes per minute, plus or minus 10 flashes.
- Type C and D steady-burn warning lights are intended to be used in a series to delineate the edge of the travel lane on detours, on lane changes, on lane closures, and on other similar conditions.
- Type A, Type C and Type D warning lights shall be installed at locations as detailed on other sheets in the plans.
- Warning lights shall not be installed on a drum that has a sign, chevron or vertical panel.
- The maximum spacing for warning lights on drums should be identical to the channelizing device spacing.

**WARNING REFLECTORS MOUNTED ON PLASTIC DRUMS AS A SUBSTITUTE FOR TYPE C (STEADY BURN) WARNING LIGHTS**

- A warning reflector or approved substitute may be mounted on a plastic drum as a substitute for a Type C, steady burn warning light at the discretion of the Contractor unless otherwise noted in the plans.
- The warning reflector shall be yellow in color and shall be manufactured using a sign substrate approved for use with plastic drums listed on the CWZTCD.
- The warning reflector shall have a minimum retroreflective surface area (one-side) of 30 square inches.
- Round reflectors shall be fully reflectorized, including the area where attached to the drum.
- Square substrates must have a minimum of 30 square inches of reflectorized sheeting. They do not have to be reflectorized where it attaches to the drum.
- The side of the warning reflector facing approaching traffic shall have sheeting meeting the color and retroreflectivity requirements for DMS 8300-Type B or Type C.
- When used near two-way traffic, both sides of the warning reflector shall be reflectorized.
- The warning reflector should be mounted on the side of the handle nearest approaching traffic.
- The maximum spacing for warning reflectors should be identical to the channelizing device spacing requirements.

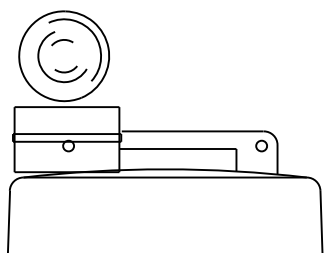

Type C Warning Light or approved substitute mounted on a drum adjacent to the travel way.

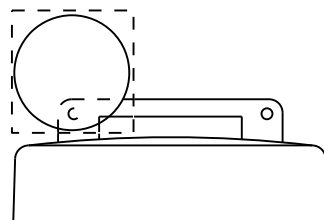

Warning reflector may be round or square. Must have a yellow reflective surface area of at least 30 square inches

DATE:  
FILE:

Arrow Boards may be located behind channelizing devices in place for a shoulder taper or merging taper, otherwise they shall be delineated with four (4) channelizing devices placed perpendicular to traffic on the upstream side of traffic.

- The Flashing Arrow Board should be used for all lane closures on multi-lane roadways, or slow moving maintenance or construction activities on the travel lanes.
- Flashing Arrow Boards should not be used on two-lane, two-way roadways, detours, diversions or work on shoulders unless the "CAUTION" display (see detail below) is used.
- The Engineer/Inspector shall choose all appropriate signs, barricades and/or other traffic control devices that should be used in conjunction with the Flashing Arrow Board.
- The Flashing Arrow Board should be able to display the following symbols:

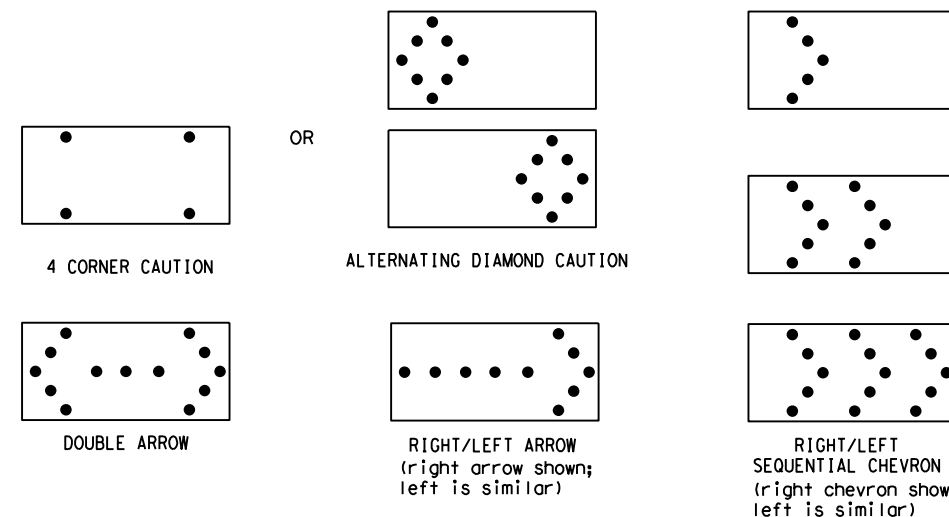

- The "CAUTION" display consists of four corner lamps flashing simultaneously, or the Alternating Diamond Caution mode as shown.
- The straight line caution display is NOT ALLOWED.
- The Flashing Arrow Board shall be capable of minimum 50 percent dimming from rated lamp voltage. The flashing rate of the lamps shall not be less than 25 nor more than 40 flashes per minute.
- Minimum lamp "on time" shall be approximately 50 percent for the flashing arrow and equal intervals of 25 percent for each sequential phase of the flashing chevron.
- The sequential arrow display is NOT ALLOWED.
- The flashing arrow display is the TxDOT standard; however, the sequential chevron display may be used during daylight operations.
- The Flashing Arrow Board shall be mounted on a vehicle, trailer or other suitable support.
- A Flashing Arrow Board SHALL NOT BE USED to laterally shift traffic.
- A full matrix PCMS may be used to simulate a Flashing Arrow Board provided it meets visibility, flash rate and dimming requirements on this sheet for the same size arrow.
- Minimum mounting height of trailer mounted Arrow Boards should be 7 feet from roadway to bottom of panel.

REQUIREMENTS			
TYPE	MINIMUM SIZE	MINIMUM NUMBER OF PANEL LAMPS	MINIMUM VISIBILITY DISTANCE
B	30 x 60	13	3/4 mile
C	48 x 96	15	1 mile

**ATTENTION**  
Flashing Arrow Boards shall be equipped with automatic dimming devices.

WHEN NOT IN USE, REMOVE THE ARROW BOARD FROM THE RIGHT-OF-WAY OR PLACE THE ARROW BOARD BEHIND CONCRETE TRAFFIC BARRIER OR GUARDRAIL.

**FLASHING ARROW BOARDS**

SHEET 7 OF 12

**TRUCK-MOUNTED ATTENUATORS**

- Truck-mounted attenuators (TMA) used on TxDOT facilities must meet the requirements outlined in the Manual for Assessing Safety Hardware (MASH).
- Refer to the CWZTCD for the requirements of Level 2 or Level 3 TMAs.
- Refer to the CWZTCD for a list of approved TMAs.
- TMAs are required on freeways unless otherwise noted in the plans.
- A TMA should be used anytime that it can be positioned 30 to 100 feet in advance of the area of crew exposure without adversely affecting the work performance.
- The only reason a TMA should not be required is when a work area is spread down the roadway and the work crew is an extended distance from the TMA.



**BARRICADE AND CONSTRUCTION ARROW PANEL, REFLECTORS, WARNING LIGHTS & ATTENUATOR**

**BC (7) -21**

FILE:	bc-21.dgn	DN:	TxDOT	CR:	TxDOT	OW:	TxDOT	CK:	TxDOT
© TxDOT	November 2002	CONT	SECT	JOB	HIGHWAY				
REVISIONS		0918	00	392	VA				
9-07	8-14	DIST	COUNTY		SHEET NO.				
7-13	5-21	DAL	DALLAS, ETC.		14				

DISCLAIMER: The use of this standard is governed by the "Texas Engineering Practice Act". No warranty of any kind is made by TxDOT for any purpose whatsoever. TxDOT assumes no responsibility for the conversion of this standard to other formats or for incorrect results or damages resulting from its use.

DATE: FILE:

**GENERAL NOTES**

- For long term stationary work zones on freeways, drums shall be used as the primary channelizing device.
- For intermediate term stationary work zones on freeways, drums should be used as the primary channelizing device but may be replaced in tangent sections by vertical panels, or 42" two-piece cones. In tangent sections, one-piece cones may be used with the approval of the Engineer but only if personnel are present on the project at all times to maintain the cones in proper position and location.
- For short term stationary work zones on freeways, drums are the preferred channelizing device but may be replaced in tapers, transitions and tangent sections by vertical panels, two-piece cones or one-piece cones as approved by the Engineer.
- Drums and all related items shall comply with the requirements of the current version of the "Texas Manual on Uniform Traffic Control Devices" (TMUTCD) and the "Compliant Work Zone Traffic Control Devices List" (CWZTCD).
- Drums, bases, and related materials shall exhibit good workmanship and shall be free from objectionable marks or defects that would adversely affect their appearance or serviceability.
- The Contractor shall have a maximum of 24 hours to replace any plastic drums identified for replacement by the Engineer/Inspector. The replacement device must be an approved device.

**GENERAL DESIGN REQUIREMENTS**

Pre-qualified plastic drums shall meet the following requirements:

- Plastic drums shall be a two-piece design; the "body" of the drum shall be the top portion and the "base" shall be the bottom.
- The body and base shall lock together in such a manner that the body separates from the base when impacted by a vehicle traveling at a speed of 20 MPH or greater but prevents accidental separation due to normal handling and/or air turbulence created by passing vehicles.
- Plastic drums shall be constructed of lightweight flexible, and deformable materials. The Contractor shall NOT use metal drums or single piece plastic drums as channelization devices or sign supports.
- Drums shall present a profile that is a minimum of 18 inches in width at the 36 inch height when viewed from any direction. The height of drum unit (body installed on base) shall be a minimum of 36 inches and a maximum of 42 inches.
- The top of the drum shall have a built-in handle for easy pickup and shall be designed to drain water and not collect debris. The handle shall have a minimum of two widely spaced 9/16 inch diameter holes to allow attachment of a warning light, warning reflector unit or approved compliant sign.
- The exterior of the drum body shall have a minimum of four alternating orange and white retroreflective circumferential stripes not less than 4 inches nor greater than 8 inches in width. Any non-reflectORIZED space between any two adjacent stripes shall not exceed 2 inches in width.
- Bases shall have a maximum width of 36 inches, a maximum height of 4 inches, and a minimum of two footholds of sufficient size to allow base to be held down while separating the drum body from the base.
- Plastic drums shall be constructed of ultra-violet stabilized, orange, high-density polyethylene (HDPE) or other approved material.
- Drum body shall have a maximum unballasted weight of 11 lbs.
- Drum and base shall be marked with manufacturer's name and model number.

**RETROREFLECTIVE SHEETING**

- The stripes used on drums shall be constructed of sheeting meeting the color and retroreflectivity requirements of Departmental Materials Specification DMS-8300, "Sign Face Materials." Type A or Type B reflective sheeting shall be supplied unless otherwise specified in the plans.
- The sheeting shall be suitable for use on and shall adhere to the drum surface such that, upon vehicular impact, the sheeting shall remain adhered in-place and exhibit no delaminating, cracking, or loss of retroreflectivity other than that loss due to abrasion of the sheeting surface.

**BALLAST**

- Unballasted bases shall be large enough to hold up to 50 lbs. of sand. This base, when filled with the ballast material, should weigh between 35 lbs (minimum) and 50 lbs (maximum). The ballast may be sand in one to three sandbags separate from the base, sand in a sand-filled plastic base, or other ballasting devices as approved by the Engineer. Stacking of sandbags will be allowed, however height of sandbags above pavement surface may not exceed 12 inches.
- Bases with built-in ballast shall weigh between 40 lbs. and 50 lbs. Built-in ballast can be constructed of an integral crumb rubber base or a solid rubber base.
- Recycled truck tire sidewalls may be used for ballast on drums approved for this type of ballast on the CWZTCD list.
- The ballast shall not be heavy objects, water, or any material that would become hazardous to motorists, pedestrians, or workers when the drum is struck by a vehicle.
- When used in regions susceptible to freezing, drums shall have drainage holes in the bottoms so that water will not collect and freeze becoming a hazard when struck by a vehicle.
- Ballast shall not be placed on top of drums.
- Adhesives may be used to secure base of drums to pavement.

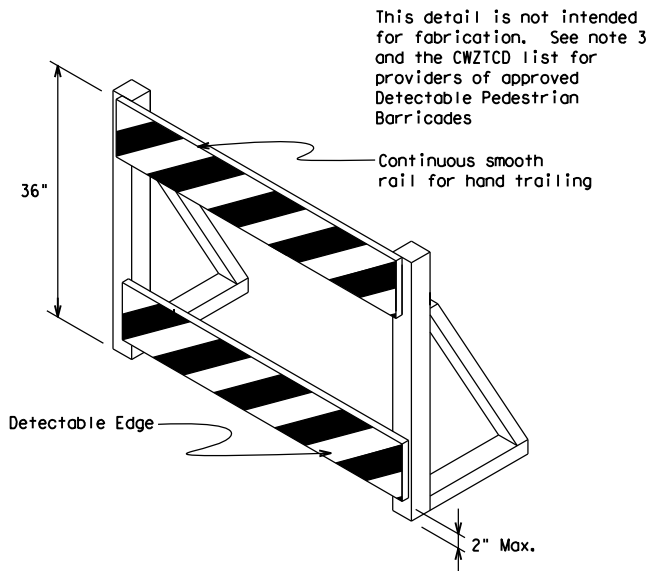
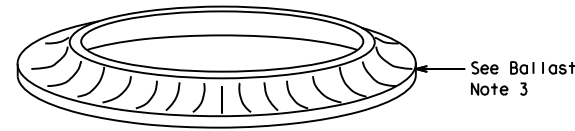
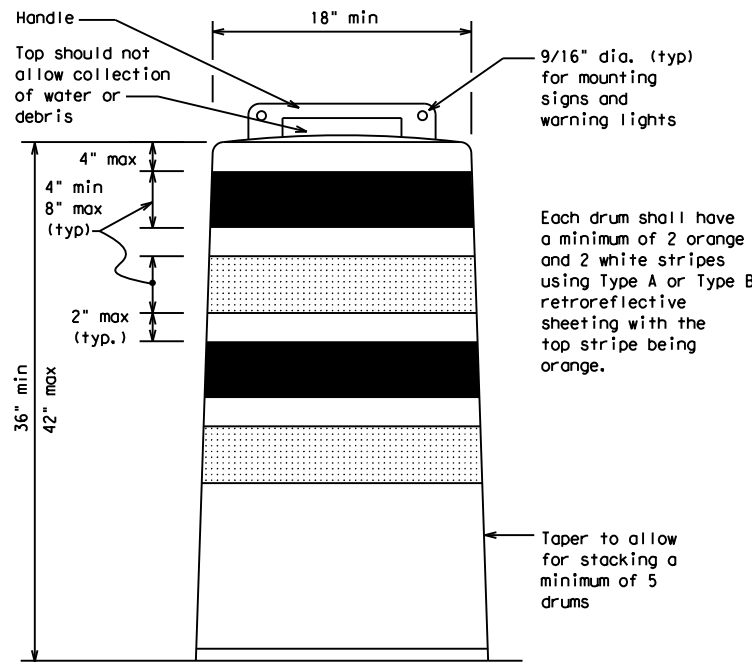

**DETECTABLE PEDESTRIAN BARRICADES**

- When existing pedestrian facilities are disrupted, closed, or relocated in a TTC zone, the temporary facilities shall be detectable and include accessibility features consistent with the features present in the existing pedestrian facility. Refer to WZ(BTS-2) for Pedestrian Control requirements for Sidewalk Diversions, Sidewalk Detours and Crosswalk Closures.
- Where pedestrians with visual disabilities normally use the closed sidewalk, a Detectable Pedestrian Barricade shall be placed across the full width of the closed sidewalk instead of a Type 3 Barricade.
- Detectable pedestrian barricades similar to the one pictured above, longitudinal channelizing devices, some concrete barriers, and wood or chain link fencing with a continuous detectable edging can satisfactorily delineate a pedestrian path.
- Tape, rope, or plastic chain strung between devices are not detectable, do not comply with the design standards in the "Americans with Disabilities Act Accessibility Guidelines (ADAAG)" and should not be used as a control for pedestrian movements.
- Warning lights shall not be attached to detectable pedestrian barricades.
- Detectable pedestrian barricades should use 8" nominal barricade rails as shown on BC(10) provided that the top rail provides a smooth continuous rail suitable for hand trailing with no splinters, burrs, or sharp edges.

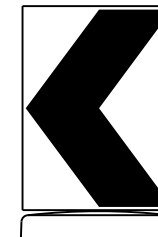

18" x 24" Sign  
(Maximum Sign Dimension)  
Chevron CW1-8, Opposing Traffic Lane  
Divider, Driveway sign D70a, Keep Right  
R4 series or other signs as approved  
by Engineer

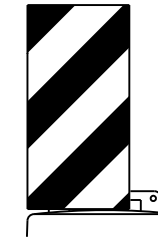

12" x 24"  
Vertical Panel  
mount with diagonals  
sloping down towards  
travel way

Plywood, Aluminum or Metal sign  
substrates shall NOT be used on  
plastic drums

**SIGNS, CHEVRONS, AND VERTICAL PANELS MOUNTED ON PLASTIC DRUMS**

- Signs used on plastic drums shall be manufactured using substrates listed on the CWZTCD.
- Chevrons and other work zone signs with an orange background shall be manufactured with Type B<sub>FL</sub> or Type C<sub>FL</sub> Orange sheeting meeting the color and retroreflectivity requirements of DMS-8300, "Sign Face Material," unless otherwise specified in the plans.
- Vertical Panels shall be manufactured with orange and white sheeting meeting the requirements of DMS-8300 Type A or Type B. Diagonal stripes on Vertical Panels shall slope down toward the intended traveled lane.
- Other sign messages (text or symbolic) may be used as approved by the Engineer. Sign dimensions shall not exceed 18 inches in width or 24 inches in height, except for the R9 series signs discussed in note 8 below.
- Signs shall be installed using a 1/2 inch bolt (nominal) and nut, two washers, and one locking washer for each connection.
- Mounting bolts and nuts shall be fully engaged and adequately torqued. Bolts should not extend more than 1/2 inch beyond nuts.
- Chevrons may be placed on drums on the outside of curves, on merging tapers or on shifting tapers. When used in these locations, they may be placed on every drum or spaced not more than on every third drum. A minimum of three (3) should be used at each location called for in the plans.
- R9-9, R9-10, R9-11 and R9-11a Sidewalk Closed signs which are 24 inches wide may be mounted on plastic drums, with approval of the Engineer.

SHEET 8 OF 12



**BARRICADE AND CONSTRUCTION CHANNELIZING DEVICES**

**BC (8) - 21**

FILE:	bc-21.dgn	DN:	TxDOT	CR:	TxDOT	DW:	TxDOT	CK:	TxDOT
© TxDOT	November 2002	CONT	SECT	JOB	HIGHWAY				
REVISIONS		0918	00	392	VA				
4-03	8-14								
9-07	5-21								
7-13									
		DIST	COUNTY		SHEET NO.				
		DAL	DALLAS, ETC.		15				

DISCLAIMER: The use of this standard is governed by the "Texas Engineering Practice Act". No warranty of any kind is made by TxDOT for any purpose whatsoever. TxDOT assumes no responsibility for the conversion of this standard to other formats or for incorrect results or damages resulting from its use.

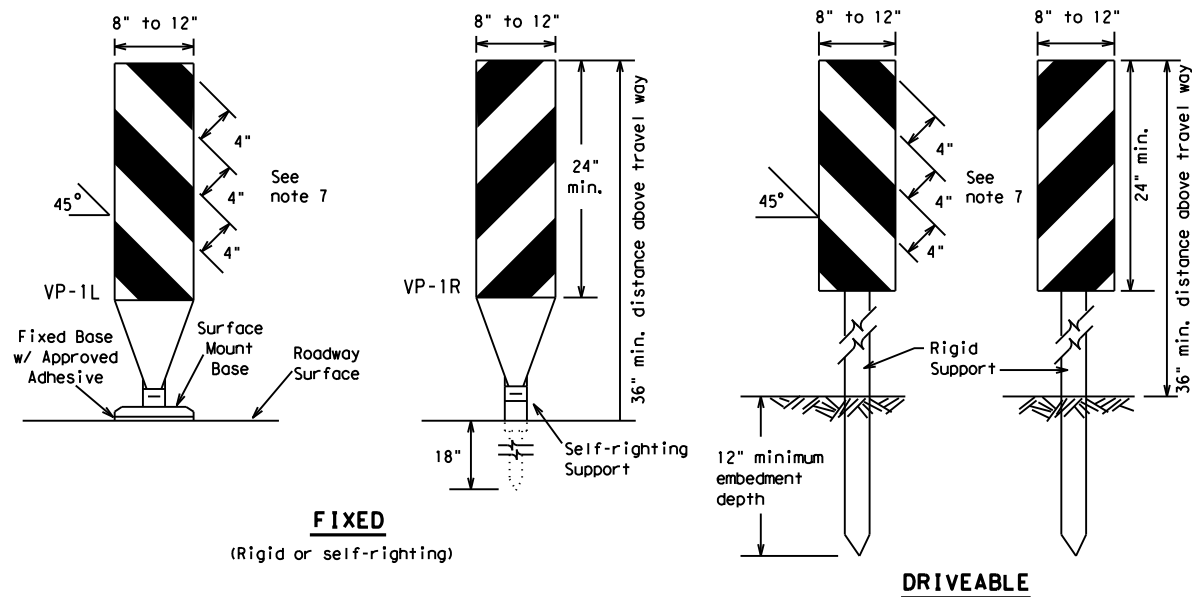

**FIXED**  
(Rigid or self-righting)

**DRIVEABLE**

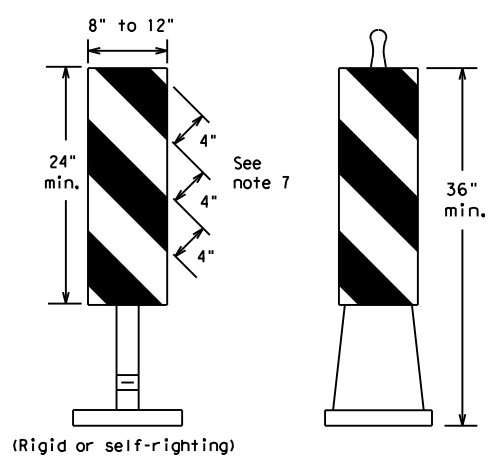

**PORTABLE**

**VERTICAL PANELS (VPs)**

- Vertical Panels (VP's) are normally used to channelize traffic or divide opposing lanes of traffic.
- VP's may be used in daytime or nighttime situations. They may be used at the edge of shoulder drop-offs and other areas such as lane transitions where positive daytime and nighttime delineation is required. The Engineer/Inspector shall refer to the Roadway Design Manual for additional requirements on the use VP's for drop-offs.
- VP's should be mounted back to back if used at the edge of cuts adjacent to two-way two lane roadways. Stripes are to be reflective orange and reflective white and should always slope downward toward the travel lane.
- VP's used on expressways and freeways or other high speed roadways, may have more than 270 square inches of retroreflective area facing traffic.
- Self-righting supports are available with portable base. See "Compliant Work Zone Traffic Control Devices List" (CWZTCD).
- Sheeting for the VP's shall be retroreflective Type A or Type B conforming to Departmental Material Specification DMS-8300, unless noted otherwise.
- Where the height of reflective material on the vertical panel is 36 inches or greater, a panel stripe of 6 inches shall be used.

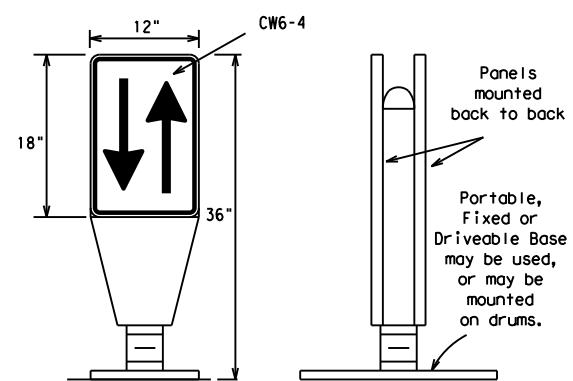

**OPPOSING TRAFFIC LANE DIVIDERS (OTLD)**

- Opposing Traffic Lane Dividers (OTLD) are delineation devices designed to convert a normal one-way roadway section to two-way operation. OTLD's are used on temporary centerlines. The upward and downward arrows on the sign's face indicate the direction of traffic on either side of the divider. The base is secured to the pavement with an adhesive or rubber weight to minimize movement caused by a vehicle impact or wind gust.
- The OTLD may be used in combination with 42" cones or VPs.
- Spacing between the OTLD shall not exceed 500 feet. 42" cones or VPs placed between the OTLD's should not exceed 100 foot spacing.
- The OTLD shall be orange with a black non-reflective legend. Sheeting for the OTLD shall be retroreflective Type B<sub>FL</sub> or Type C<sub>FL</sub> conforming to Departmental Material Specification DMS-8300, unless noted otherwise. The legend shall meet the requirements of DMS-8300.

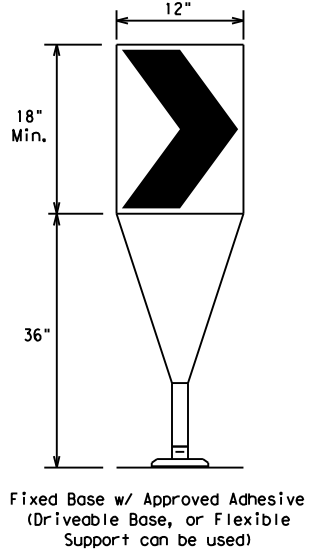

- The chevron shall be a vertical rectangle with a minimum size of 12 by 18 inches.
- Chevrons are intended to give notice of a sharp change of alignment with the direction of travel and provide additional emphasis and guidance for vehicle operators with regard to changes in horizontal alignment of the roadway.
- Chevrons, when used, shall be erected on the outside of a sharp curve or turn, or on the far side of an intersection. They shall be in line with and at right angles to approaching traffic. Spacing should be such that the motorist always has three in view, until the change in alignment eliminates its need.
- To be effective, the chevron should be visible for at least 500 feet.
- Chevrons shall be orange with a black nonreflective legend. Sheeting for the chevron shall be retroreflective Type B<sub>FL</sub> or Type C<sub>FL</sub> conforming to Departmental Material Specification DMS-8300, unless noted otherwise. The legend shall meet the requirements of DMS-8300.
- For Long Term Stationary use on tapers or transitions on freeways and divided highways, self-righting chevrons may be used to supplement plastic drums but not to replace plastic drums.

**CHEVRONS**

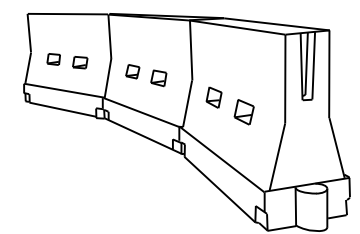

**LONGITUDINAL CHANNELIZING DEVICES (LCD)**

- LCDs are crashworthy, lightweight, deformable devices that are highly visible, have good target value and can be connected together. They are not designed to contain or redirect a vehicle on impact.
- LCDs may be used instead of a line of cones or drums.
- LCDs shall be placed in accordance to application and installation requirements specific to the device, and used only when shown on the CWZTCD list.
- LCDs should not be used to provide positive protection for obstacles, pedestrians or workers.
- LCDs shall be supplemented with retroreflective delineation as required for temporary barriers on BC(7) when placed roughly parallel to the travel lanes.
- LCDs used as barricades placed perpendicular to traffic should have at least one row of reflective sheeting meeting the requirements for barricade rails as shown on BC(10). Place reflective sheeting near the top of the LCD along the full length of the device.

**WATER BALLASTED SYSTEMS USED AS BARRIERS**

- Water ballasted systems used as barriers shall not be used solely to channelize road users, but also to protect the work space per the appropriate Manual for Assessing Safety Hardware (MASH) crashworthiness requirements based on roadway speed and barrier application.
- Water ballasted systems used to channelize vehicular traffic shall be supplemented with retroreflective delineation or channelizing devices to improve daytime/nighttime visibility. They may also be supplemented with pavement markings.
- Water ballasted systems used as barriers shall be placed in accordance to application and installation requirements specific to the device, and used only when shown on the CWZTCD list.
- Water ballasted systems used as barriers should not be used for a merging taper except in low speed (less than 45 MPH) urban areas. When used on a taper in a low speed urban area, the taper shall be delineated and the taper length should be designed to optimize road user operations considering the available geometric conditions.
- When water ballasted systems used as barriers have blunt ends exposed to traffic, they should be attenuated as per manufacturer recommendations or flared to a point outside the clear zone.

If used to channelize pedestrians, longitudinal channelizing devices or water ballasted systems must have a continuous detectable bottom for users of long canes and the top of the unit shall not be less than 32 inches in height.

**HOLLOW OR WATER BALLASTED SYSTEMS USED AS LONGITUDINAL CHANNELIZING DEVICES OR BARRIERS**

**GENERAL NOTES**

- Work Zone channelizing devices illustrated on this sheet may be installed in close proximity to traffic and are suitable for use on high or low speed roadways. The Engineer/Inspector shall ensure that spacing and placement is uniform and in accordance with the "Texas Manual on Uniform Traffic Control Devices" (TMUTCD).
- Channelizing devices shown on this sheet may have a driveable, fixed or portable base. The requirement for self-righting channelizing devices must be specified in the General Notes or other plan sheets.
- Channelizing devices on self-righting supports should be used in work zone areas where channelizing devices are frequently impacted by errant vehicles or vehicle related wind gusts making alignment of the channelizing devices difficult to maintain. Locations of these devices shall be detailed elsewhere in the plans. These devices shall conform to the TMUTCD and the "Compliant Work Zone Traffic Control Devices List" (CWZTCD).
- The Contractor shall maintain devices in a clean condition and replace damaged, nonreflective, faded, or broken devices and bases as required by the Engineer/Inspector. The Contractor shall be required to maintain proper device spacing and alignment.
- Portable bases shall be fabricated from virgin and/or recycled rubber. The portable bases shall weigh a minimum of 30 lbs.
- Pavement surfaces shall be prepared in a manner that ensures proper bonding between the adhesives, the fixed mount bases and the pavement surface. Adhesives shall be prepared and applied according to the manufacturer's recommendations.
- The installation and removal of channelizing devices shall not cause detrimental effects to the final pavement surfaces, including pavement surface discoloration or surface integrity. Driveable bases shall not be permitted on final pavement surfaces. The Engineer/Inspector shall approve all application and removal procedures of fixed bases.

Posted Speed	Formula	Minimum Desirable Taper Lengths * *			Suggested Maximum Spacing of Channelizing Devices	
		10' Offset	11' Offset	12' Offset	On a Taper	On a Tangent
30	L = WS <sup>2</sup> / 60	150'	165'	180'	30'	60'
35		205'	225'	245'	35'	70'
40		265'	295'	320'	40'	80'
45	L = WS	450'	495'	540'	45'	90'
50		500'	550'	600'	50'	100'
55		550'	605'	660'	55'	110'
60		600'	660'	720'	60'	120'
65		650'	715'	780'	65'	130'
70		700'	770'	840'	70'	140'
75		750'	825'	900'	75'	150'
80		800'	880'	960'	80'	160'

\* \* \* Taper lengths have been rounded off.  
L=Length of Taper (FT.) W=Width of Offset (FT.)  
S=Posted Speed (MPH)

**SUGGESTED MAXIMUM SPACING OF CHANNELIZING DEVICES AND MINIMUM DESIRABLE TAPER LENGTHS**

SHEET 9 OF 12



**BARRICADE AND CONSTRUCTION CHANNELIZING DEVICES**

**BC (9) - 21**

FILE: bc-21.dgn	DN: TxDOT	CK: TxDOT	DW: TxDOT	CR: TxDOT
© TxDOT November 2002	CONT	SECT	JOB	HIGHWAY
REVISIONS	0918	00	392	VA
9-07 8-14	DIST	COUNTY	SHEET NO.	
7-13 5-21	DAL	DALLAS, ETC.	16	

DATE: FILE:



DISCLAIMER: The use of this standard is governed by the "Texas Engineering Practice Act". No warranty of any kind is made by TxDOT for any purpose whatsoever. TxDOT assumes no responsibility for the conversion of this standard to other formats or for incorrect results or damages resulting from its use.

**TYPE 3 BARRICADES**

1. Refer to the Compliant Work Zone Traffic Control Devices List (CWZTCD) for details of the Type 3 Barricades and a list of all materials used in the construction of Type 3 Barricades.
2. Type 3 Barricades shall be used at each end of construction projects closed to all traffic.
3. Barricades extending across a roadway should have stripes that slope downward in the direction toward which traffic must turn in detouring. When both right and left turns are provided, the chevron striping may slope downward in both directions from the center of the barricade. Where no turns are provided at a closed road, striping should slope downward in both directions toward the center of roadway.
4. Striping of rails, for the right side of the roadway, should slope downward to the left. For the left side of the roadway, striping should slope downward to the right.
5. Identification markings may be shown only on the back of the barricade rails. The maximum height of letters and/or company logos used for identification shall be 1".
6. Barricades shall not be placed parallel to traffic unless an adequate clear zone is provided.
7. Warning lights shall NOT be installed on barricades.
8. Where barricades require the use of weights to keep from turning over, the use of sandbags with dry, cohesionless sand is recommended. The sandbags will be tied shut to keep the sand from spilling and to maintain a constant weight. Sand bags shall not be stacked in a manner that covers any portion of a barricade rails reflective sheeting. Rock, concrete, iron, steel or other solid objects will NOT be permitted. Sandbags should weigh a minimum of 35 lbs and a maximum of 50 lbs. Sandbags shall be made of a durable material that tears upon vehicular impact. Rubber (such as tire inner tubes) shall not be used for sandbags. Sandbags shall only be placed along or upon the base supports of the device and shall not be suspended above ground level or hung with rope, wire, chains or other fasteners.
9. Sheeting for barricades shall be retroreflective Type A or Type B conforming to Departmental Material Specification DMS-8300 unless otherwise noted.

Barricades shall NOT be used as a sign support.



**TYPICAL STRIPING DETAIL FOR BARRICADE RAIL**

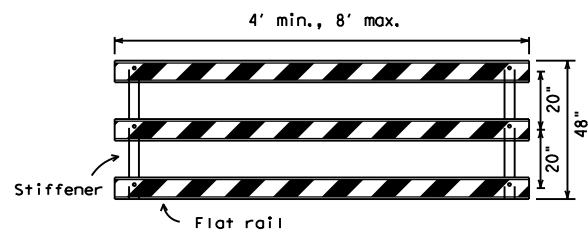

**TYPICAL PANEL DETAIL FOR SKID OR POST TYPE BARRICADES**

Each roadway of a divided highway shall be barricaded in the same manner.

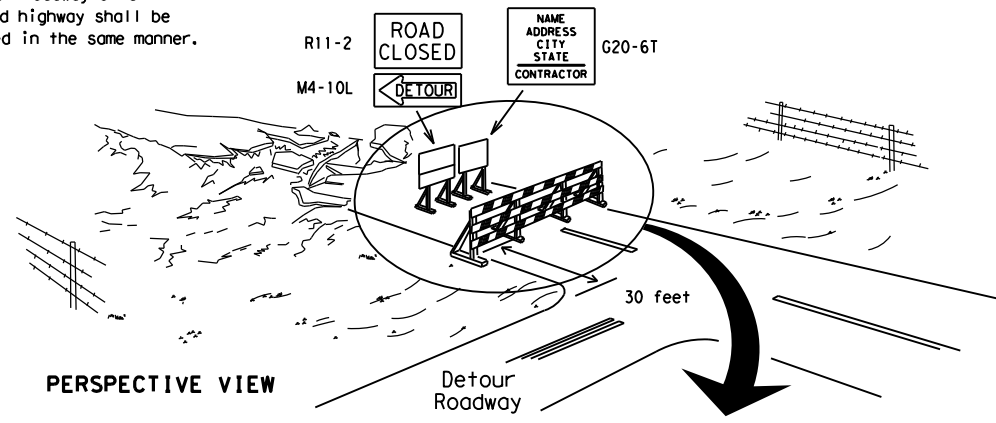

PERSPECTIVE VIEW

The three rails on Type 3 barricades shall be reflectorized orange and reflective white stripes on one side facing one-way traffic and both sides for two-way traffic. Barricade striping should slant downward in the direction of detour.

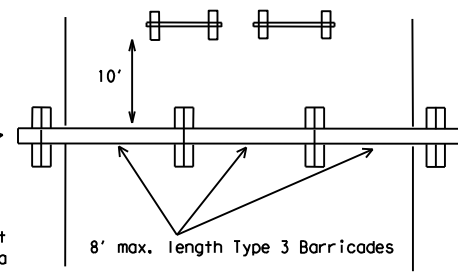

PLAN VIEW

1. Signs should be mounted on independent supports at a 7 foot mounting height in center of roadway. The signs should be a minimum of 10 feet behind Type 3 Barricades.
2. Advance signing shall be as specified elsewhere in the plans.

**TYPE 3 BARRICADE (POST AND SKID) TYPICAL APPLICATION**

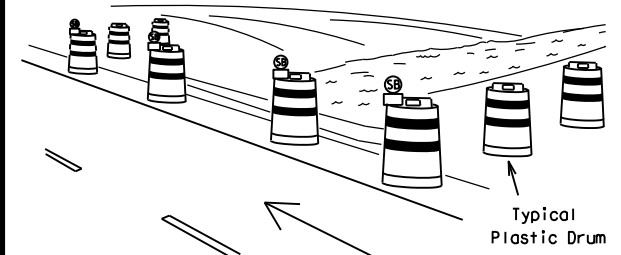

PERSPECTIVE VIEW

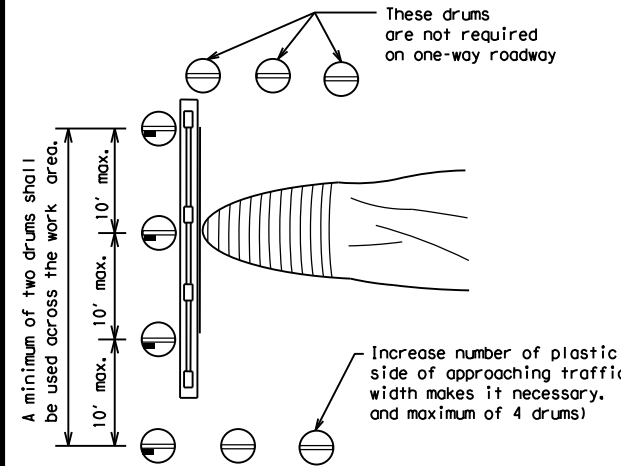

PLAN VIEW

**CULVERT WIDENING OR OTHER ISOLATED WORK WITHIN THE PROJECT LIMITS**

LEGEND	
	Plastic drum
	Plastic drum with steady burn light or yellow warning reflector
	Steady burn warning light or yellow warning reflector

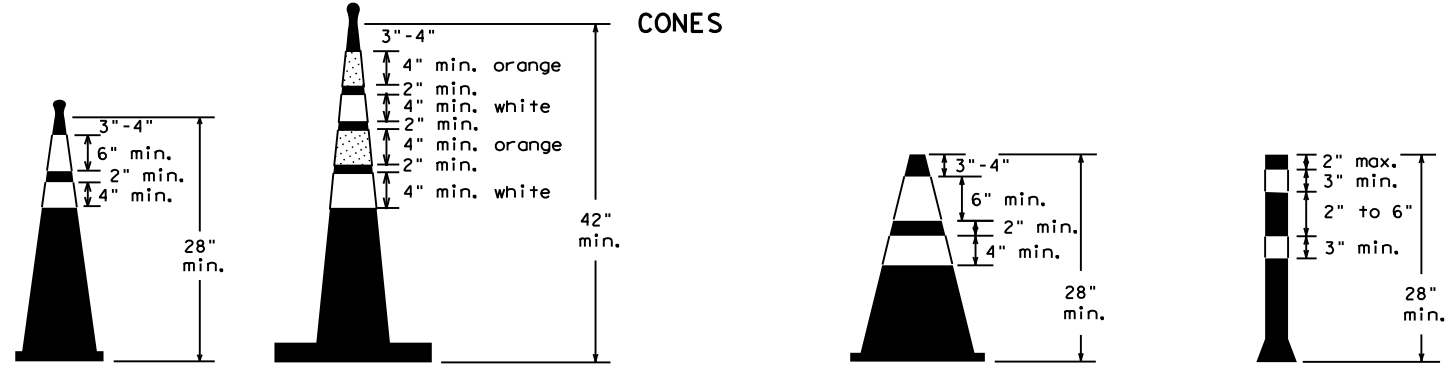

Two-Piece cones

One-Piece cones

Tubular Marker

28" Cones shall have a minimum weight of 9 1/2 lbs.  
42" 2-piece cones shall have a minimum weight of 30 lbs. including base.

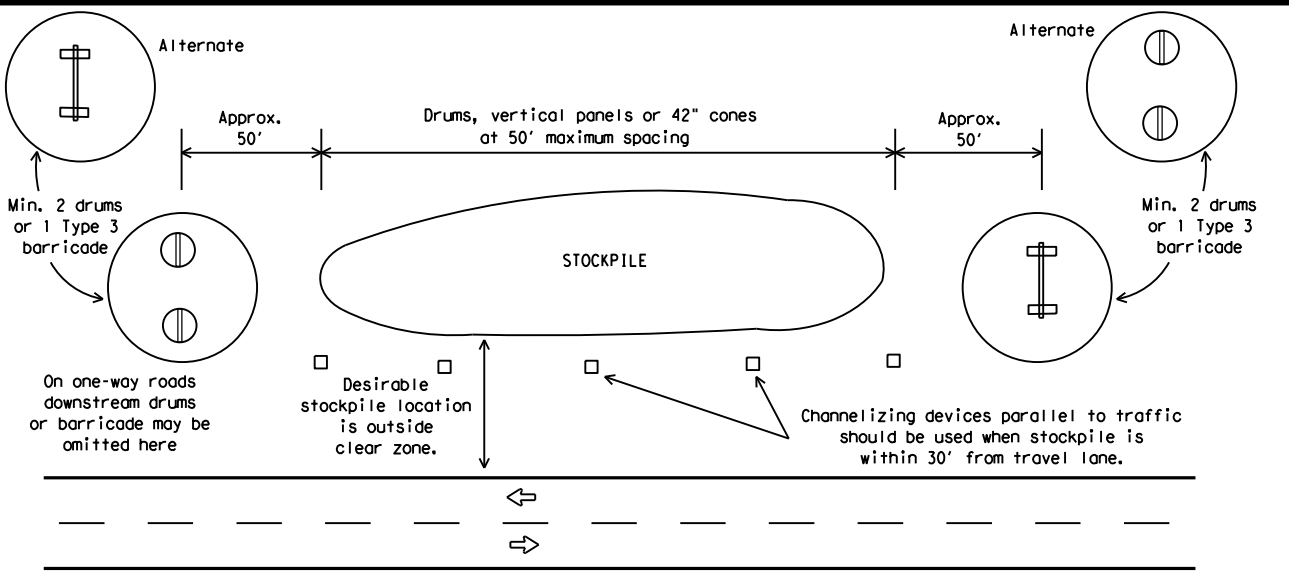

**TRAFFIC CONTROL FOR MATERIAL STOCKPILES**

1. Traffic cones and tubular markers shall be predominantly orange, and meet the height and weight requirements shown above.
2. One-piece cones have the body and base of the cone molded in one consolidated unit. Two-piece cones have a cone shaped body and a separate rubber base, or ballast, that is added to keep the device upright and in place.
3. Two-piece cones may have a handle or loop extending up to 8" above the minimum height shown, in order to aid in retrieving the device.
4. Cones or tubular markers shall have white or white and orange reflective bands as shown above. The reflective bands shall have a smooth, sealed outer surface and meet the requirements of Departmental Material Specification DMS-8300 Type A or Type B.
5. 28" cones and tubular markers are generally suitable for short duration and short-term stationary work as defined on BC(4). These should not be used for intermediate-term or long-term stationary work unless personnel is on-site to maintain them in their proper upright position.
6. 42" two-piece cones, vertical panels or drums are suitable for all work zone durations.
7. Cones or tubular markers used on each project should be of the same size and shape.



**BARRICADE AND CONSTRUCTION CHANNELIZING DEVICES**

**BC (10) - 21**

FILE: bc-21.dgn	DN: TxDOT	CK: TxDOT	DW: TxDOT	CR: TxDOT
© TxDOT November 2002	CONT	SECT	JOB	HIGHWAY
REVISIONS	0918	00	392	VA
9-07 8-14	DIST	COUNTY	SHEET NO.	
7-13 5-21	DAL	DALLAS, ETC.	17	

DATE: FILE:

## WORK ZONE PAVEMENT MARKINGS

### GENERAL

- The Contractor shall be responsible for maintaining work zone and existing pavement markings, in accordance with the standard specifications and special provisions, on all roadways open to traffic within the CSJ limits unless otherwise stated in the plans.
- Color, patterns and dimensions shall be in conformance with the "Texas Manual on Uniform Traffic Control Devices" (TMUTCD).
- Additional supplemental pavement marking details may be found in the plans or specifications.
- Pavement markings shall be installed in accordance with the TMUTCD and as shown on the plans.
- When short term markings are required on the plans, short term markings shall conform with the TMUTCD, the plans and details as shown on the Standard Plan Sheet WZ(STPM).
- When standard pavement markings are not in place and the roadway is opened to traffic, DO NOT PASS signs shall be erected to mark the beginning of the sections where passing is prohibited and PASS WITH CARE signs at the beginning of sections where passing is permitted.
- All work zone pavement markings shall be installed in accordance with Item 662, "Work Zone Pavement Markings."

### RAISED PAVEMENT MARKERS

- Raised pavement markers are to be placed according to the patterns on BC(12).
- All raised pavement markers used for work zone markings shall meet the requirements of Item 672, "RAISED PAVEMENT MARKERS" and Departmental Material Specification DMS-4200 or DMS-4300.

### PREFABRICATED PAVEMENT MARKINGS

- Removable prefabricated pavement markings shall meet the requirements of DMS-8241.
- Non-removable prefabricated pavement markings (foil back) shall meet the requirements of DMS-8240.

### MAINTAINING WORK ZONE PAVEMENT MARKINGS

- The Contractor will be responsible for maintaining work zone pavement markings within the work limits.
- Work zone pavement markings shall be inspected in accordance with the frequency and reporting requirements of work zone traffic control device inspections as required by Form 599.
- The markings should provide a visible reference for a minimum distance of 300 feet during normal daylight hours and 160 feet when illuminated by automobile low-beam headlights at night, unless sight distance is restricted by roadway geometrics.
- Markings failing to meet this criteria within the first 30 days after placement shall be replaced at the expense of the Contractor as per Specification Item 662.

### REMOVAL OF PAVEMENT MARKINGS

- Pavement markings that are no longer applicable, could create confusion or direct a motorist toward or into the closed portion of the roadway shall be removed or obliterated before the roadway is opened to traffic.
- The above shall not apply to detours in place for less than three days, where flaggers and/or sufficient channelizing devices are used in lieu of markings to outline the detour route.
- Pavement markings shall be removed to the fullest extent possible, so as not to leave a discernable marking. This shall be by any method approved by TxDOT Specification Item 677 for "Eliminating Existing Pavement Markings and Markers".
- The removal of pavement markings may require resurfacing or seal coating portions of the roadway as described in Item 677.
- Subject to the approval of the Engineer, any method that proves to be successful on a particular type pavement may be used.
- Blast cleaning may be used but will not be required unless specifically shown in the plans.
- Over-painting of the markings SHALL NOT BE permitted.
- Removal of raised pavement markers shall be as directed by the Engineer.
- Removal of existing pavement markings and markers will be paid for directly in accordance with Item 677, "ELIMINATING EXISTING PAVEMENT MARKINGS AND MARKERS," unless otherwise stated in the plans.
- Black-out marking tape may be used to cover conflicting existing markings for periods less than two weeks when approved by the Engineer.

## Temporary Flexible-Reflective Roadway Marker Tabs

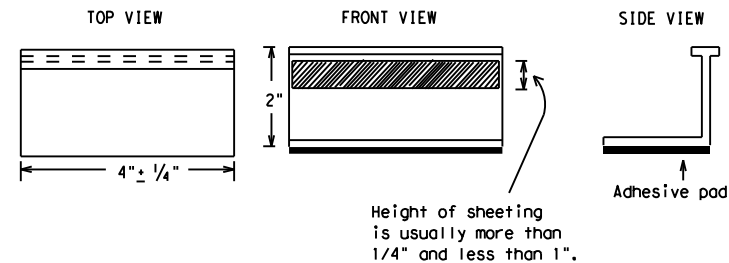

**STAPLES OR NAILS SHALL NOT BE USED TO SECURE  
TEMPORARY FLEXIBLE-REFLECTIVE ROADWAY MARKER  
TABS TO THE PAVEMENT SURFACE**

- Temporary flexible-reflective roadway marker tabs used as guidemarks shall meet the requirements of DMS-8242.
- Tabs detailed on this sheet are to be inspected and accepted by the Engineer or designated representative. Sampling and testing is not normally required, however at the option of the Engineer, either "A" or "B" below may be imposed to assure quality before placement on the roadway.
  - Select five (5) or more tabs at random from each lot or shipment and submit to the Construction Division, Materials and Pavement Section to determine specification compliance.
  - Select five (5) tabs and perform the following test. Affix five (5) tabs at 24 inch intervals on an asphaltic pavement in a straight line. Using a medium size passenger vehicle or pickup, run over the markers with the front and rear tires at a speed of 35 to 40 miles per hour, four (4) times in each direction. No more than one (1) out of the five (5) reflective surfaces shall be lost or displaced as a result of this test.
- Small design variances may be noted between tab manufacturers.
- See Standard Sheet WZ(STPM) for tab placement on new pavements. See Standard Sheet TCP(7-1) for tab placement on seal coat work.

### RAISED PAVEMENT MARKERS USED AS GUIDEMARKS

- Raised pavement markers used as guidemarks shall be from the approved product list, and meet the requirements of DMS-4200.
- All temporary construction raised pavement markers provided on a project shall be of the same manufacturer.
- Adhesive for guidemarks shall be bituminous material hot applied or butyl rubber pad for all surfaces, or thermoplastic for concrete surfaces.

Guidemarks shall be designated as:  
 YELLOW - (two amber reflective surfaces with yellow body).  
 WHITE - (one silver reflective surface with white body).

DEPARTMENTAL MATERIAL SPECIFICATIONS	
PAVEMENT MARKERS (REFLECTORIZED)	DMS-4200
TRAFFIC BUTTONS	DMS-4300
EPOXY AND ADHESIVES	DMS-6100
BITUMINOUS ADHESIVE FOR PAVEMENT MARKERS	DMS-6130
PERMANENT PREFABRICATED PAVEMENT MARKINGS	DMS-8240
TEMPORARY REMOVABLE, PREFABRICATED PAVEMENT MARKINGS	DMS-8241
TEMPORARY FLEXIBLE, REFLECTIVE ROADWAY MARKER TABS	DMS-8242

A list of prequalified reflective raised pavement markers, non-reflective traffic buttons, roadway marker tabs and other pavement markings can be found at the Material Producer List web address shown on BC(1).

SHEET 11 OF 12

<span style="font-size: small; vertical-align: middle;">Texas Department of Transportation</span>		<span style="font-size: x-small;">Traffic Safety Division Standard</span>
<h1 style="margin: 0;">BARRICADE AND CONSTRUCTION PAVEMENT MARKINGS</h1> <h2 style="margin: 0;">BC(11)-21</h2>		
FILE: bc-21.dgn	DN: TxDOT	CK: TxDOT
©TxDOT February 1998	CONT: 0918	SECT: 00
REVISIONS	JOB: 392	HIGHWAY: VA
2-98 9-07 5-21	DIST: DAL	COUNTY: DALLAS, ETC.
1-02 7-13	SHEET NO. 18	
11-02 8-14		

DISCLAIMER: The use of this standard is governed by the "Texas Engineering Practice Act". No warranty of any kind is made by TxDOT for any purpose whatsoever. TxDOT assumes no responsibility for the conversion of this standard to other formats or for incorrect results or damages resulting from its use.

DATE:  
FILE:

## PAVEMENT MARKING PATTERNS



REFLECTORIZED PAVEMENT MARKINGS - PATTERN A

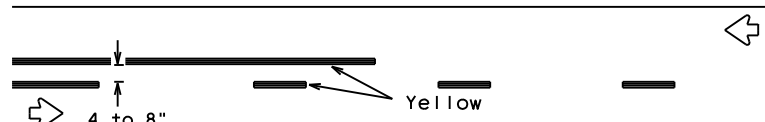

REFLECTORIZED PAVEMENT MARKINGS - PATTERN B

Pattern A is the TxDOT Standard, however Pattern B may be used if approved by the Engineer. Prefabricated markings may be substituted for reflectORIZED pavement markings.

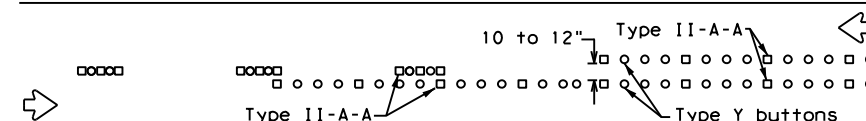

RAISED PAVEMENT MARKERS - PATTERN A

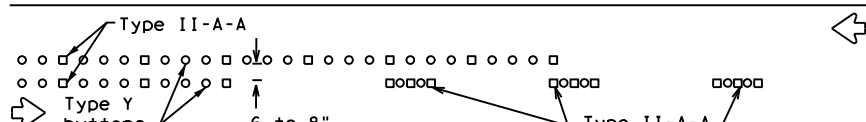

RAISED PAVEMENT MARKERS - PATTERN B

## CENTER LINE & NO-PASSING ZONE BARRIER LINES FOR TWO-LANE, TWO-WAY HIGHWAYS



REFLECTORIZED PAVEMENT MARKINGS

Prefabricated markings may be substituted for reflectORIZED pavement markings.



RAISED PAVEMENT MARKERS

## EDGE & LANE LINES FOR DIVIDED HIGHWAY



REFLECTORIZED PAVEMENT MARKINGS

Prefabricated markings may be substituted for reflectORIZED pavement markings.

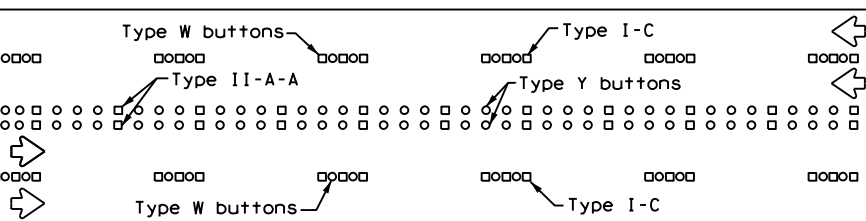

RAISED PAVEMENT MARKERS

## LANE & CENTER LINES FOR MULTILANE UNDIVIDED HIGHWAYS

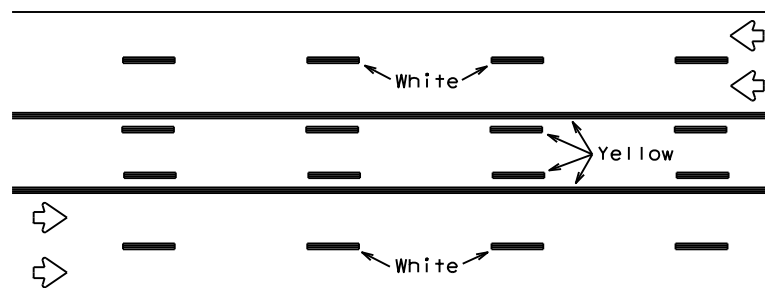

REFLECTORIZED PAVEMENT MARKINGS

Prefabricated markings may be substituted for reflectORIZED pavement markings.

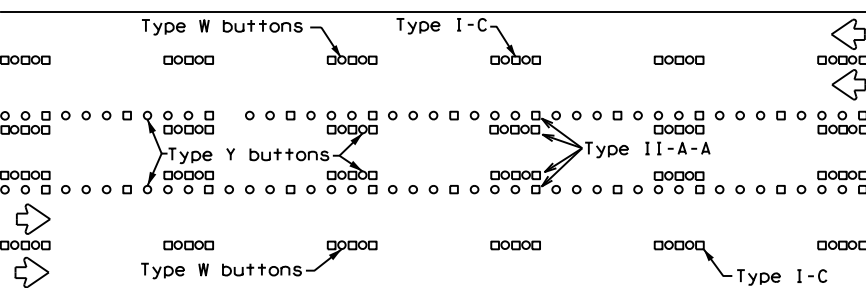

RAISED PAVEMENT MARKERS

## TWO-WAY LEFT TURN LANE

## STANDARD WORK ZONE PAVEMENT MARKINGS DETAILS

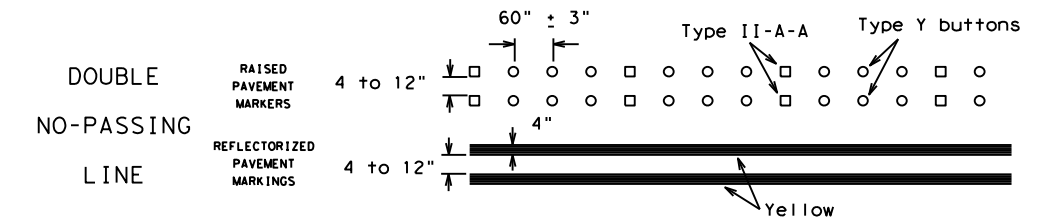

### SOLID LINES

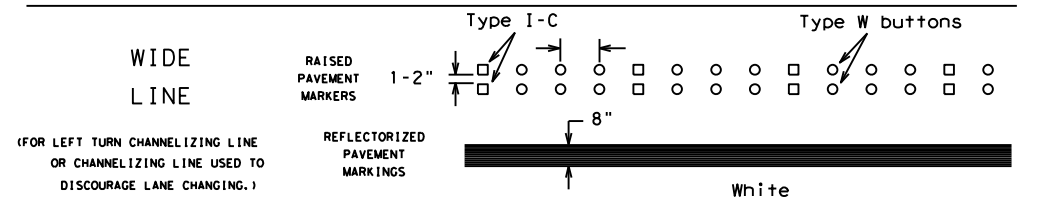
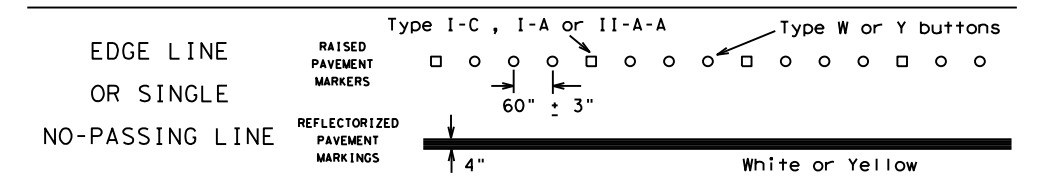

### BROKEN LINES

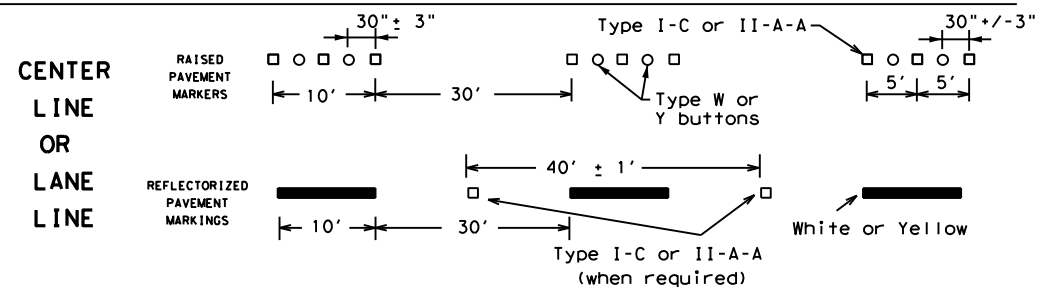

### AUXILIARY OR LANEDROP LINE

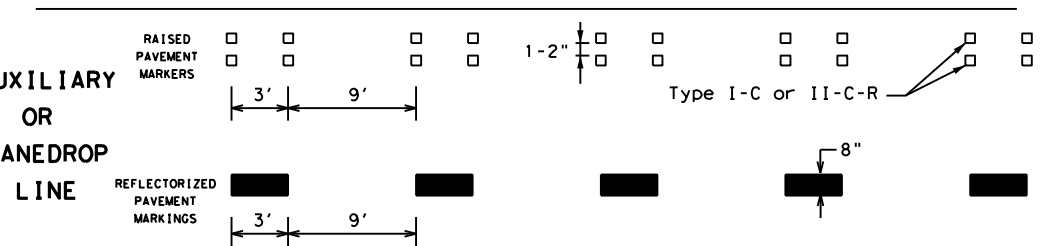

### REMOVABLE MARKINGS WITH RAISED PAVEMENT MARKERS

If raised pavement markers are used to supplement REMOVABLE markings, the markers shall be applied to the top of the tape at the approximate mid length of tape used for broken lines or at 20 foot spacing for solid lines. This allows an easier removal of raised pavement markers and tape.

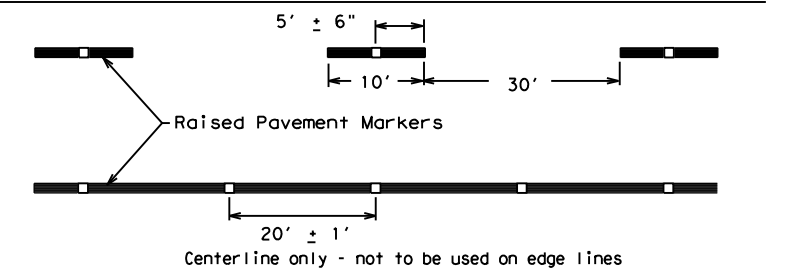

SHEET 12 OF 12



## BARRICADE AND CONSTRUCTION PAVEMENT MARKING PATTERNS

BC(12)-21

FILE: bc-21.dgn	DN: TxDOT	CK: TxDOT	DW: TxDOT	CR: TxDOT
©TxDOT February 1998	CONT	SECT	JOB	HIGHWAY
REVISIONS	0918	00	392	VA
1-97 9-07 5-21	DIST	COUNTY	SHEET NO.	
2-98 7-13	DAL	DALLAS, ETC.	19	
11-02 8-14				

DISCLAIMER: The use of this standard is governed by the "Texas Engineering Practice Act". No warranty of any kind is made by TxDOT for any purpose whatsoever. TxDOT assumes no responsibility for the conversion of this standard to other formats or for incorrect results or damages resulting from its use.

DATE:  
FILE:

DISCLAIMER: The use of this standard is governed by the "Texas Engineering Practice Act". No warranty of any kind is made by TxDOT for any purpose whatsoever. TxDOT assumes no responsibility for the conversion of this standard to other formats or for incorrect results or damages resulting from its use.

DATE: FILE:

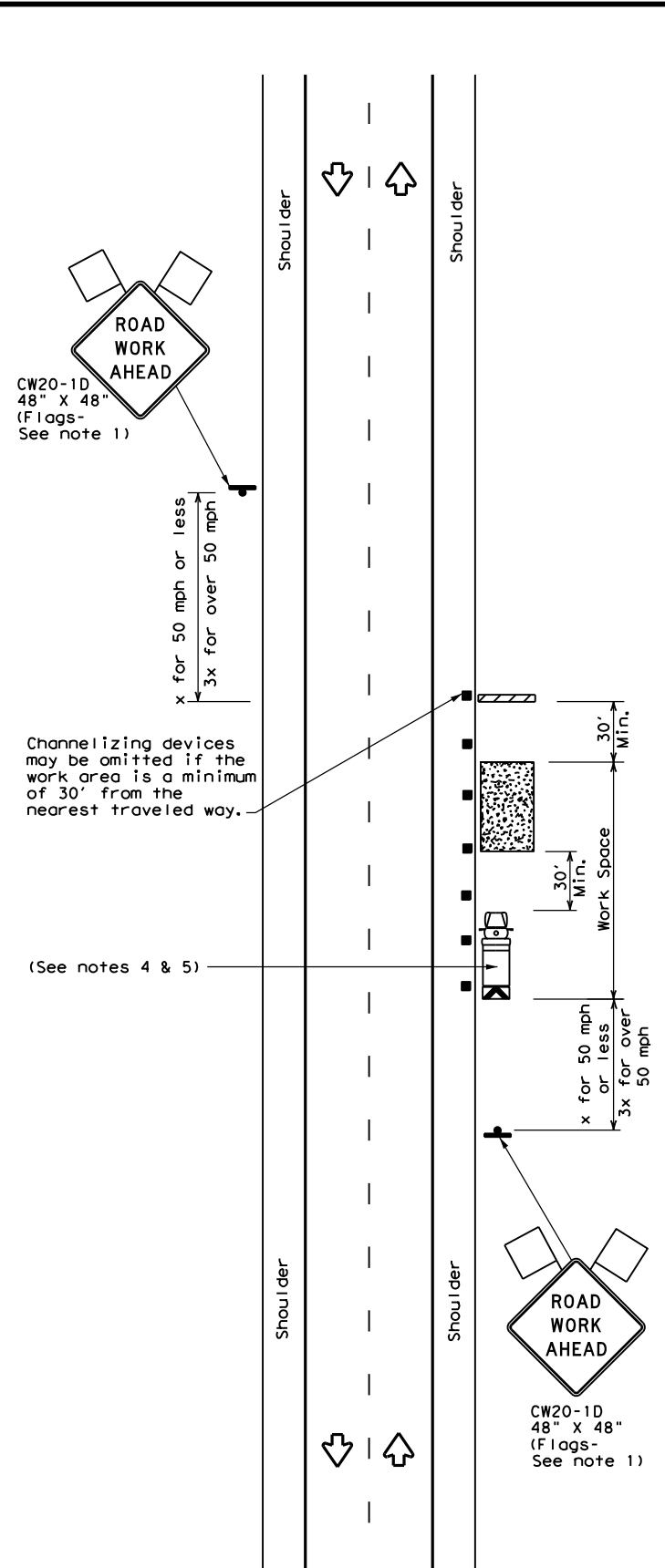

TCP (2-1a)

**WORK SPACE NEAR SHOULDER**  
Conventional Roads

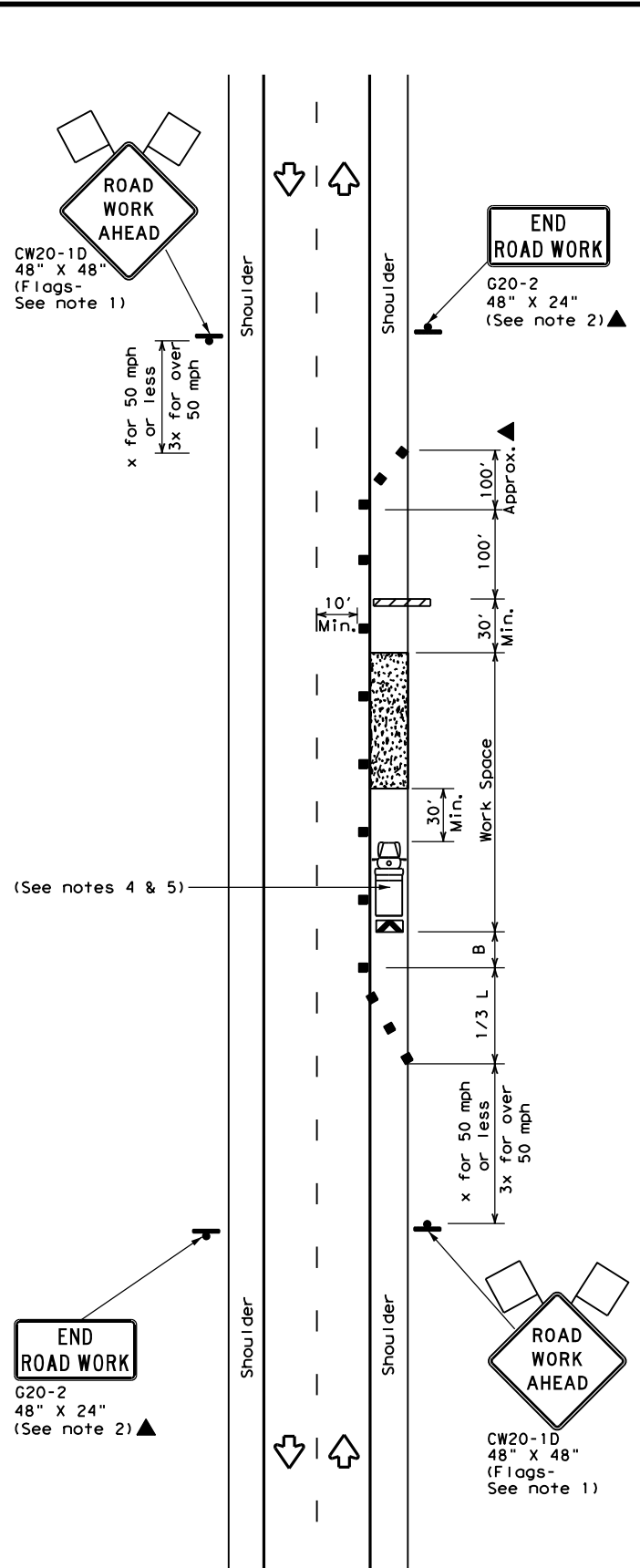

TCP (2-1b)

**WORK SPACE ON SHOULDER**  
Conventional Roads

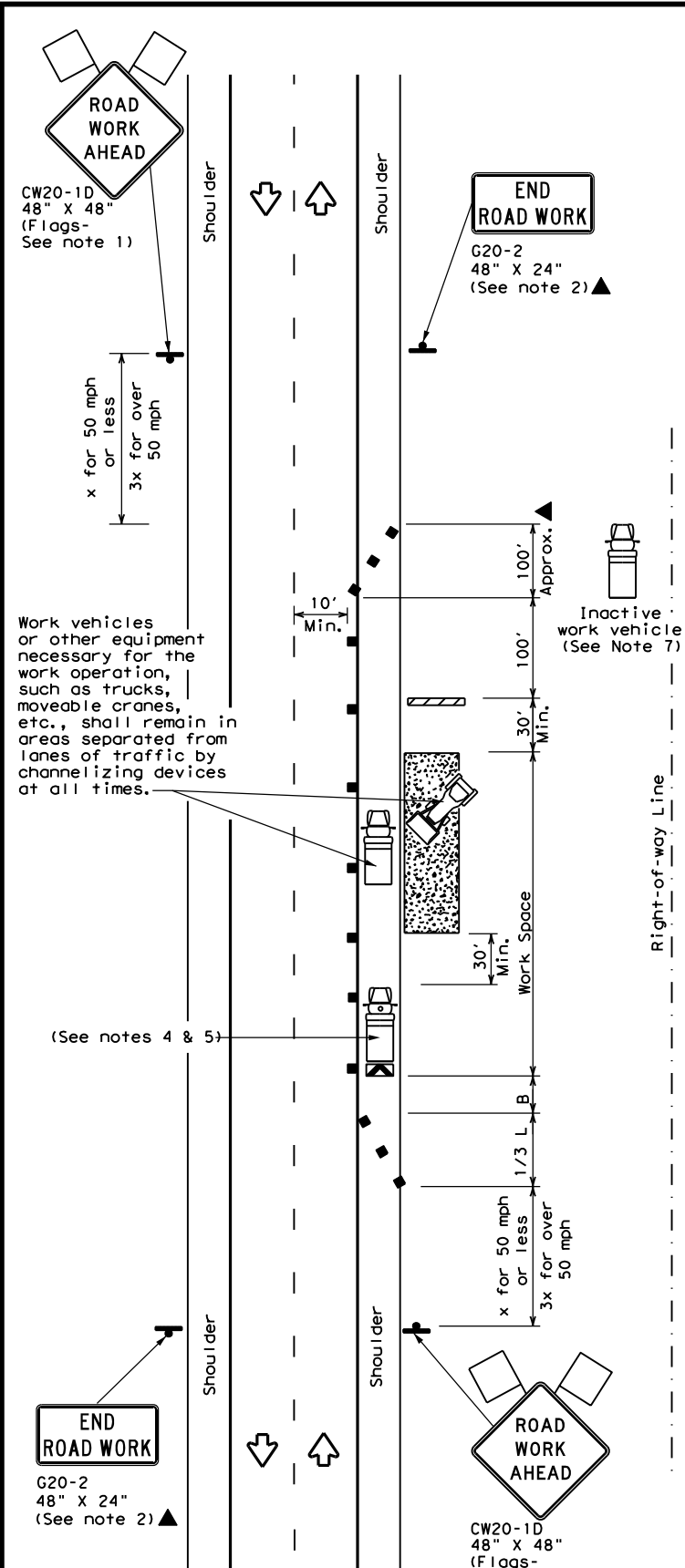

TCP (2-1c)

**WORK VEHICLES ON SHOULDER**  
Conventional Roads

LEGEND			
	Type 3 Barricade		Channelizing Devices
	Heavy Work Vehicle		Truck Mounted Attenuator (TMA)
	Trailer Mounted Flashing Arrow Board		Portable Changeable Message Sign (PCMS)
	Sign		Traffic Flow
	Flag		Flagger

Posted Speed *	Formula	Minimum Desirable Taper Lengths **			Suggested Maximum Spacing of Channelizing Devices		Minimum Sign Spacing "X" Distance	Suggested Longitudinal Buffer Space "B"
		10' Offset	11' Offset	12' Offset	On a Taper	On a Tangent		
30	$L = \frac{WS^2}{60}$	150'	165'	180'	30'	60'	120'	90'
35		205'	225'	245'	35'	70'	160'	120'
40		265'	295'	320'	40'	80'	240'	155'
45	L = WS	450'	495'	540'	45'	90'	320'	195'
50		500'	550'	600'	50'	100'	400'	240'
55		550'	605'	660'	55'	110'	500'	295'
60		600'	660'	720'	60'	120'	600'	350'
65		650'	715'	780'	65'	130'	700'	410'
70		700'	770'	840'	70'	140'	800'	475'
75		750'	825'	900'	75'	150'	900'	540'

\* Conventional Roads Only  
\*\* Taper lengths have been rounded off.  
L=Length of Taper (FT) W=Width of Offset (FT) S=Posted Speed (MPH)

TYPICAL USAGE				
MOBILE	SHORT DURATION	SHORT TERM STATIONARY	INTERMEDIATE TERM STATIONARY	LONG TERM STATIONARY
	✓	✓	✓	✓

**GENERAL NOTES**

- Flags attached to signs where shown, are REQUIRED.
- All traffic control devices illustrated are REQUIRED, except those denoted with the triangle symbol may be omitted when stated in the plans, or for routine maintenance work, when approved by the Engineer.
- Stockpiled material should be placed a minimum of 30 feet from nearest traveled way.
- Shadow Vehicle with TMA and high intensity rotating, flashing, oscillating or strobe lights. A Shadow Vehicle with a TMA should be used anytime it can be positioned 30 to 100 feet in advance of the area of crew exposure without adversely affecting the performance or quality of the work. If workers are no longer present but road or work conditions require the traffic control to remain in place, Type 3 Barricades or other channelizing devices may be substituted for the Shadow Vehicle and TMA.
- Additional Shadow Vehicles with TMAs may be positioned off the paved surface, next to those shown in order to protect a wider work space.
- See TCP(5-1) for shoulder work on divided highways, expressways and freeways.
- Inactive work vehicles or other equipment should be parked near the right-of-way line and not parked on the paved shoulder.
- CW21-5 "SHOULDER WORK" signs may be used in place of CW20-1D "ROAD WORK AHEAD" signs for shoulder work on conventional roadways.



**TRAFFIC CONTROL PLAN**  
**CONVENTIONAL ROAD**  
**SHOULDER WORK**

**TCP (2-1) - 18**

FILE: tcp2-1-18.dgn	DN:	CK:	DW:	CK:
© TxDOT December 1985	CONT	SECT	JOB	HIGHWAY
REVISIONS	0918	00	392	VA
2-94 4-98	DIST	COUNTY	SHEET NO.	
8-95 2-12	DAL	DALLAS, ETC.	20	
1-97 2-18				

DISCLAIMER: The use of this standard is governed by the "Texas Engineering Practice Act". No warranty of any kind is made by TxDOT for any purpose whatsoever. TxDOT assumes no responsibility for the conversion of this standard to other formats or for incorrect results or damages resulting from its use.

DATE: FILE:

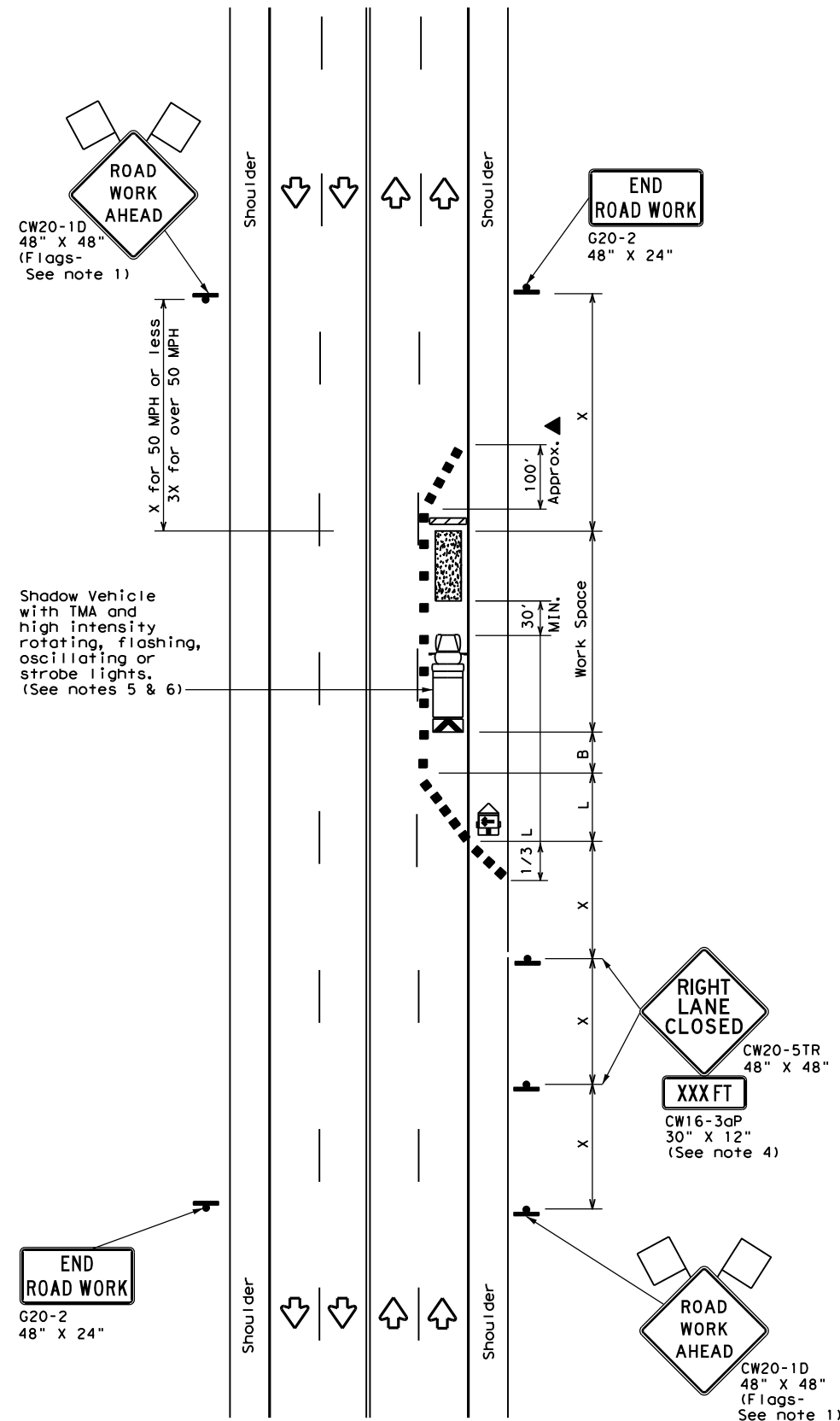

TCP (2-4a)  
**ONE LANE CLOSED**

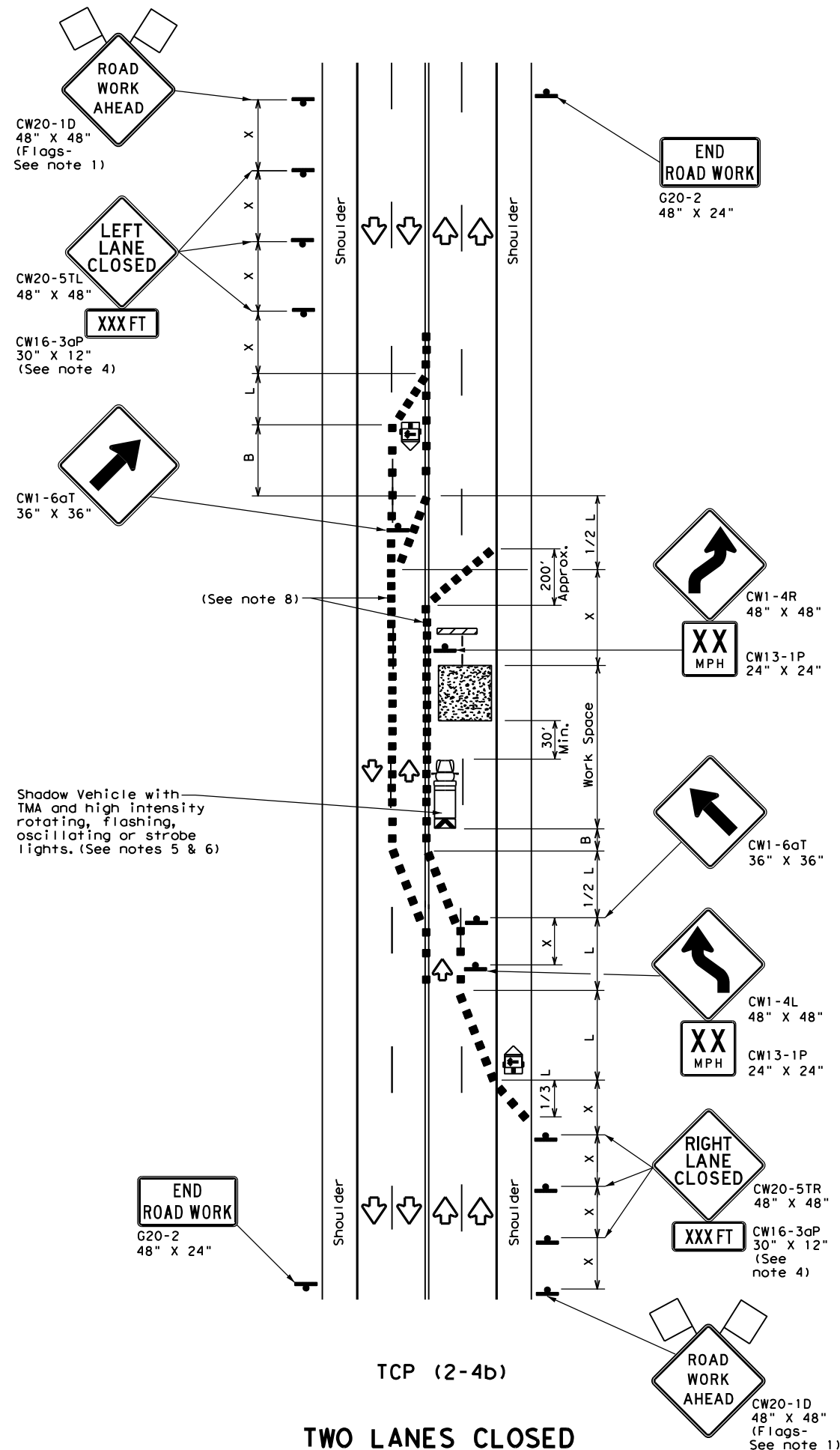

TCP (2-4b)  
**TWO LANES CLOSED**

LEGEND			
	Type 3 Barricade		Channelizing Devices
	Heavy Work Vehicle		Truck Mounted Attenuator (TMA)
	Trailer Mounted Flashing Arrow Board		Portable Changeable Message Sign (PCMS)
	Sign		Traffic Flow
	Flag		Flagger

Posted Speed *	Formula	Minimum Desirable Taper Lengths **			Suggested Maximum Spacing of Channelizing Devices		Minimum Sign Spacing "x" Distance	Suggested Longitudinal Buffer Space "B"
		10' Offset	11' Offset	12' Offset	On a Taper	On a Tangent		
30	L = WS <sup>2</sup> / 60	150'	165'	180'	30'	60'	120'	90'
35		205'	225'	245'	35'	70'	160'	120'
40		265'	295'	320'	40'	80'	240'	155'
45	L = WS	450'	495'	540'	45'	90'	320'	195'
50		500'	550'	600'	50'	100'	400'	240'
55		550'	605'	660'	55'	110'	500'	295'
60		600'	660'	720'	60'	120'	600'	350'
65		650'	715'	780'	65'	130'	700'	410'
70		700'	770'	840'	70'	140'	800'	475'
75		750'	825'	900'	75'	150'	900'	540'

\* Conventional Roads Only  
 \*\* Taper lengths have been rounded off.  
 L=Length of Taper (FT) W=Width of Offset (FT) S=Posted Speed (MPH)

TYPICAL USAGE				
MOBILE	SHORT DURATION	SHORT TERM STATIONARY	INTERMEDIATE TERM STATIONARY	LONG TERM STATIONARY
		✓	✓	

**GENERAL NOTES**

- Flags attached to signs where shown, are REQUIRED.
- All traffic control devices illustrated are REQUIRED, except those denoted with the triangle symbol may be omitted when stated elsewhere in the plans, or for routine maintenance work, when approved by the Engineer.
- The downstream taper is optional. When used, it should be 100 feet minimum length per lane.
- For short term applications, when post mounted signs are not used, the distance legend may be shown on the sign face rather than on a CW16-3aP supplemental plaque.
- A Shadow Vehicle with a TMA should be used anytime it can be positioned 30 to 100 feet in advance of the area of crew exposure without adversely affecting the performance or quality of the work. If workers are no longer present but road or work conditions require the traffic control to remain in place, Type 3 Barricades or other channelizing devices may be substituted for the Shadow Vehicle and TMA.
- Additional Shadow Vehicles with TMAs may be positioned in each closed lane, on the shoulder or off the paved surface, next to those shown in order to protect a wider work space.

**TCP (2-4a)**

- If this TCP is used for a left lane closure, CW20-5TL "LEFT LANE CLOSED" signs shall be used and channelizing devices shall be placed on the centerline to protect the work space from opposing traffic with the arrow board placed in the closed lane near the end of the merging taper.

**TCP (2-4b)**

- For shorter durations where traffic is directed over a yellow centerline, channelizing devices which separate two-way traffic should be spaced on tapers at 20' or 15' if posted speeds are 35 mph or slower, and for tangent sections, at 1/2(S) where S is the speed in mph. This tighter devices spacing is intended for the area of conflicting markings, not the entire work zone.

		Traffic Operations Division Standard	
<b>TRAFFIC CONTROL PLAN LANE CLOSURES ON MULTILANE CONVENTIONAL ROADS</b>			
<b>TCP (2-4) - 18</b>			
FILE: tcp2-4-18.dgn	DN:	CK:	DW: CK:
© TxDOT December 1985	CONT	SECT	JOB HIGHWAY
REVISIONS	0918	00	392 VA
8-95 3-03	DIST	COUNTY	SHEET NO.
1-97 2-12	DAL	DALLAS, ETC.	21
4-98 2-18			

DISCLAIMER: The use of this standard is governed by the "Texas Engineering Practice Act". No warranty of any kind is made by TxDOT for any purpose whatsoever. TxDOT assumes no responsibility for the conversion of this standard to other formats or for incorrect results or damages resulting from its use.

DATE: FILE:

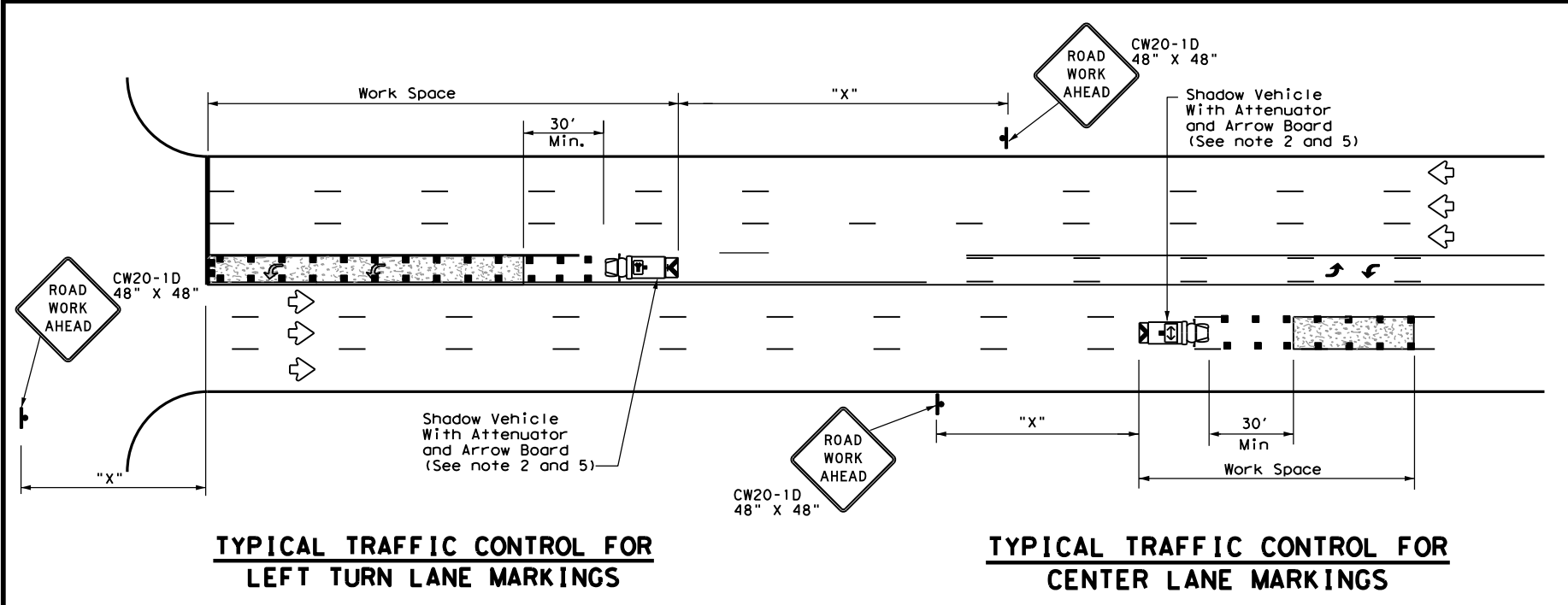
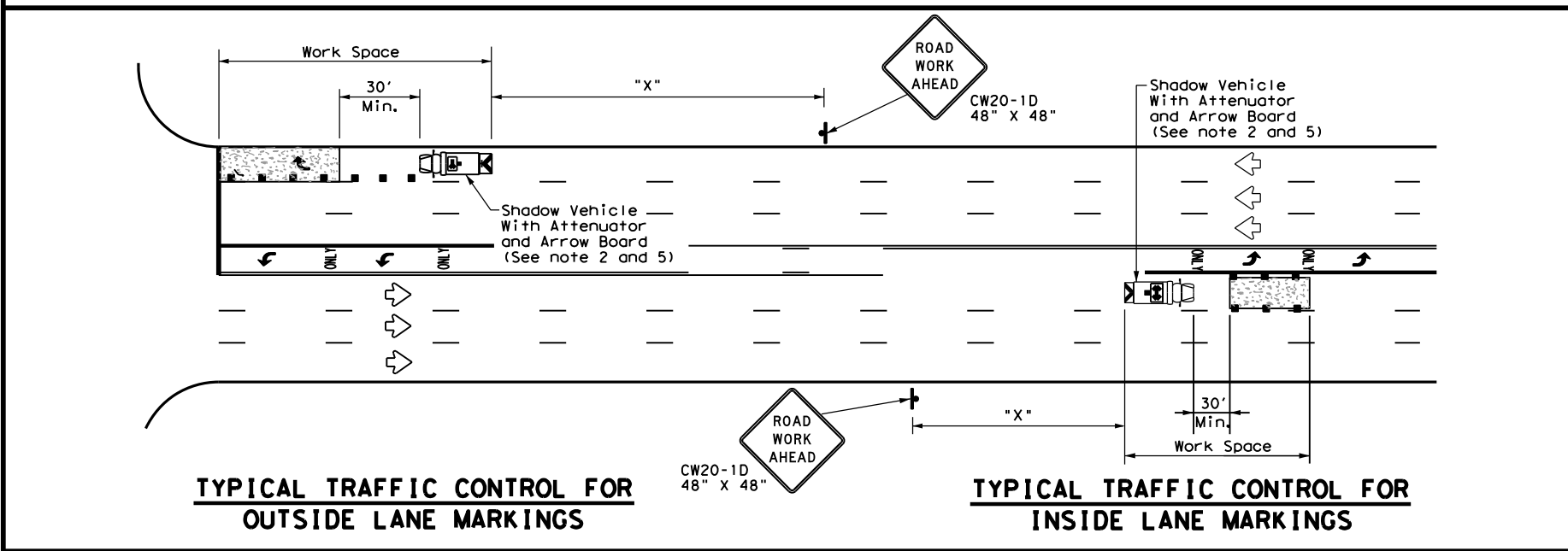
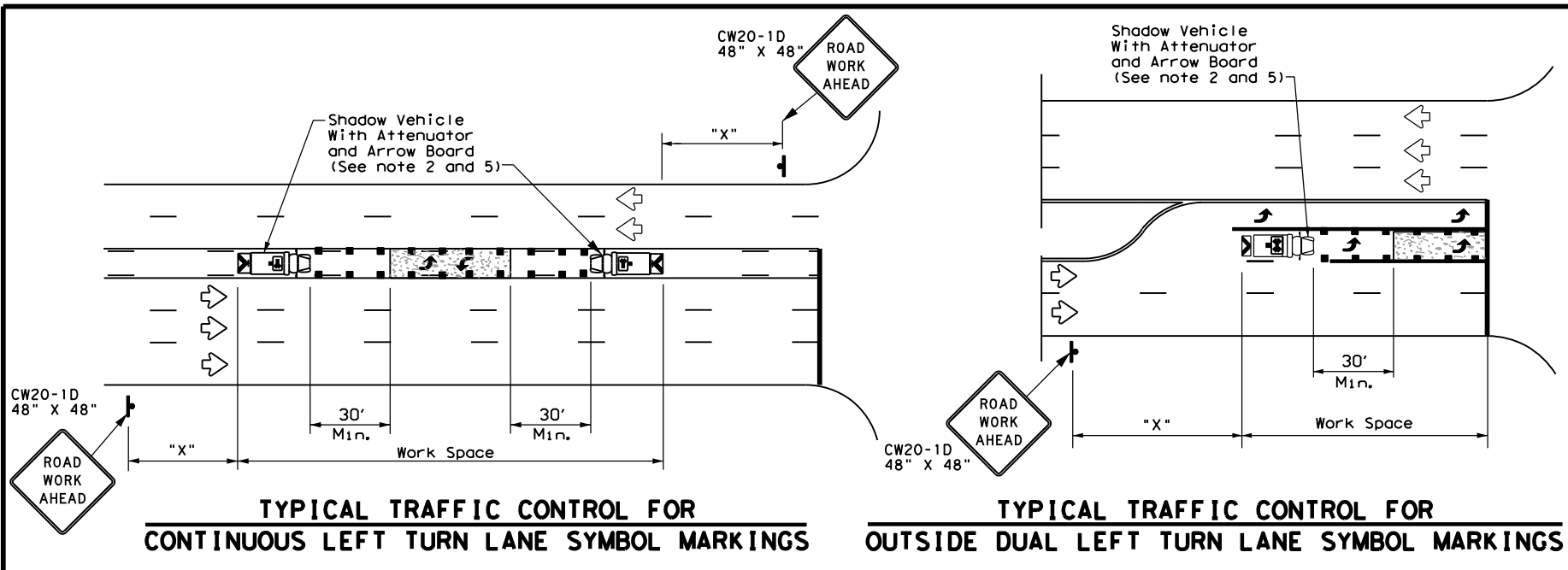

LEGEND		
*	Trail Vehicle	ARROW BOARD DISPLAY
**	Shadow Vehicle	
***	Work Vehicle	RIGHT Directional
	Heavy Work Vehicle	LEFT Directional
	Truck Mounted Attenuator (TMA)	Double Arrow
	Traffic Flow	Channelizing Devices

Posted Speed *	Formula	Minimum Desirable Taper Lengths **			Suggested Maximum Spacing of Channelizing Devices		Minimum Sign Spacing "X" Distance	Suggested Longitudinal Buffer Space "B"
		10' Offset	11' Offset	12' Offset	On a Taper	On a Tangent		
30	L = WS <sup>2</sup> / 60	150'	165'	180'	30'	60'	120'	90'
35		205'	225'	245'	35'	70'	160'	120'
40		265'	295'	320'	40'	80'	240'	155'
45	L = WS	450'	495'	540'	45'	90'	320'	195'
50		500'	550'	600'	50'	100'	400'	240'
55		550'	605'	660'	55'	110'	500'	295'
60		600'	660'	720'	60'	120'	600'	350'
65		650'	715'	780'	65'	130'	700'	410'
70		700'	770'	840'	70'	140'	800'	475'
75		750'	825'	900'	75'	150'	900'	540'

\* Conventional Roads Only  
 \*\* Taper lengths have been rounded off.  
 L=Length of Taper (FT) W=Width of Offset (FT) S=Posted Speed (MPH)

TYPICAL USAGE				
MOBILE	SHORT DURATION	SHORT TERM STATIONARY	INTERMEDIATE TERM STATIONARY	LONG TERM STATIONARY
✓				

**GENERAL NOTES**

1. This traffic control plan is for use on conventional roads posted at 45 mph or less and is intended for mobile operations that move continuously or intermittently (stopping up to approximately 15 minutes) such as short-line striping and in-lane rumble strips. When activities are anticipated to take longer amounts of time or traffic conditions warrant, a short duration or short-term stationary traffic control plan should be used.
2. A Truck Mounted Attenuator shall be used on Shadow Vehicle. Striping on the back panel of all truck mounted attenuators shall be 8" red and white reflective sheeting placed in an inverted "V" design. Reflective sheeting shall meet or exceed the reflectivity and color requirements of departmental material specification DMS-8300, Type A.
3. All traffic control devices shall be in accordance with the "Texas Manual on Uniform Traffic Control Devices" (TMUTCD), latest edition.
4. The use of yellow rotating beacons or strobe lights on vehicles are required. Blue high intensity rotating, flashing, oscillating or strobe lights when mounted on the drivers side of the vehicle may be operated simultaneously with the amber beacons or strobe lights.
5. Flashing arrow board shall be used on Shadow Vehicle. Flashing arrow board shall be Type B or Type C as per BC Standards. The arrow board operation shall be controlled from inside the truck.

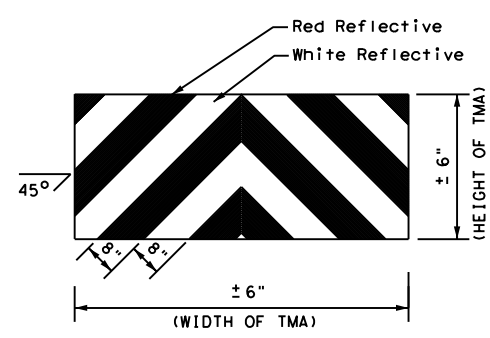

**STRIPING FOR TMA**

Texas Department of Transportation  
 Traffic Operations Division Standard

**TRAFFIC CONTROL PLAN  
 MOBILE OPERATIONS FOR  
 ISOLATED WORK AREAS  
 UNDIVIDED HIGHWAYS  
 TCP (3-4) - 13**

FILE: tcp3-4.dgn	DN: TxDOT	CK: TxDOT	DW: TxDOT	CK: TxDOT
© TxDOT July, 2013	CONT	SECT	JOB	HIGHWAY
REVISIONS	0918	00	392	VA
	DIST	COUNTY	SHEET NO.	
	DAL	DALLAS, ETC.	22	



FILE: U:\TRAFFIC PROJECTS\0918-00-392 Non-Site 9-24\Microstation Files\023 ELECTRICAL SERVICE DATA.dgn

ELECTRICAL SERVICE DATA									
DESCRIPTION	SERVICE CONDUIT SIZE	SERVICE CONDUCTOR NO/SIZE	SAFETY SWITCH AMPS	MAIN DISCONNECT	FIVE-POLE CONTACTOR AMPS	PANELBD. / LOADCENTER AMP RATING	CIRCUIT NO.	BRANCH CKT. BKR. POLE/AMPS	KVA LOAD
				CKT. BKR. POLE/AMP					
ELC SRV TY D (120/240)070(NS)SS(E)GC(O)	1 1/4"	3/#4	N/A	2P/70	30	100	T. S. Lighting #1 Lighting #2 ILSN*	1P/50 2P/20 2P/20 1P/20	<7.1
ELC SRV TY D (120/240)070(NS)SS(E)GC(U)	2"	3/#4	N/A	2P/70	30	100	T. S. Lighting #1 Lighting #2 ILSN*	1P/50 2P/20 2P/20 1P/20	<7.1
ELC SRV TY D (120/240)070(NS)SS(E)PS(U)	2"	3/#4	N/A	2P/70	30	100	T. S. Lighting #1 Lighting #2 ILSN*	1P/50 2P/20 2P/20 1P/20	<7.1
ELC SRV TY D (120/240)070(NS)SS(E)SP(O)	1 1/4"	3/#4	N/A	2P/70	30	100	T. S. Lighting #1 Lighting #2 ILSN*	1P/50 2P/20 2P/20 1P/20	<7.1

\* INTERNALLY LIGHTED STREET NAME SIGN (ILSN) ASSEMBLIES (UPON CITY REQUEST AND TXDOT APPROVAL).

NOTES:

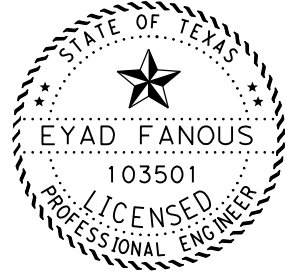
1. THIS SHEET IS FOR THE CONTRACTOR'S INFORMATION ONLY; AND IS THE TYPICAL ELECTRICAL SERVICE DATA FOR THE TYPES SPECIFIED.
2. THE ELECTRICAL SERVICE TYPE AND DESCRIPTION WILL BE SHOWN ON THE PLANS FOR EACH WORK ORDER.

					
		© 2024			
<b>ELECTRICAL SERVICE DATA</b>					
SHEET 1 OF 1					
DESIGN	FED. RD. DIV. NO.	PROJECT NO.		HIGHWAY NO.	
EF	6	(SEE TITLE SHEET)		VA	
GRAPHICS	STATE	DISTRICT	COUNTY		SHEET NO.
EF	TEXAS	DAL	DALLAS, ETC		23
CHECK SW	CONTROL	SECTION	JOB		
CHECK CMC	0918	00	392		
Eyad Fanous, P.E. 7/1/24 Signature Date					





DISCLAIMER: The use of this standard is governed by the "Texas Engineering Practice Act". No warranty of any kind is made by TxDOT for any purpose whatsoever. TxDOT assumes no responsibility for the conversion of this standard to other formats or for incorrect results or damages resulting from its use.

DATE: FILE:

## GENERAL NOTES

### CURB RAMP

1. Install a curb ramp or blended transition at each pedestrian street crossing.
2. All slopes shown are maximum allowable. Cross slopes of 1.5% and lesser running should be used. Adjust curb ramp length or grade of approach sidewalks as directed.
3. Maximum allowable cross slope on sidewalk and curb ramp surfaces is 2%.
4. The minimum sidewalk width is 5'. Where the sidewalk is adjacent to the back of curb, a 6' sidewalk width is desirable. Where a 5' sidewalk cannot be provided due to site constraints, sidewalk width may be reduced to 4' for short distances. 5' x 5' passing areas at intervals not to exceed 200' are required.
5. Turning Spaces shall be 5' x 5' minimum. Cross slope shall be maximum 2%.
6. Clear space at the bottom of curb ramps shall be a minimum of 4' x 4' wholly contained within the crosswalk and wholly outside the parallel vehicular travel path.
7. Provide flared sides where the pedestrian circulation path crosses the curb ramp. Flared sides shall be sloped at 10% maximum, measured parallel to the curb. Returned curbs may be used only where pedestrians would not normally walk across the ramp, either because the adjacent surface is planted, substantially obstructed, or otherwise protected.
8. Additional information on curb ramp location, design, light reflective value and texture may be found in the latest draft of the Proposed Guidelines for Pedestrian Facilities in the Public Right of Way (PROWAG) as published by the U.S. Architectural and Transportation Barriers Compliance Board (Access Board).
9. To serve as a pedestrian refuge area, the median should be a minimum of 6' wide, measured from back of curbs. Medians should be designed to provide accessible passage over or through them.
10. Small channelization islands, which do not provide a minimum 5' x 5' landing at the top of curb ramps, shall be cut through level with the surface of the street.
11. Crosswalk dimensions, crosswalk markings and stop bar locations shall be as shown elsewhere in the plans. At intersections where crosswalk markings are not required, curb ramps shall align with theoretical crosswalks unless otherwise directed.
12. Provide curb ramps to connect the pedestrian access route at each pedestrian street crossing. Handrails are not required on curb ramps.
13. Curb ramps and landings shall be constructed and paid for in accordance with Item 531 "Sidewalks".
14. Place concrete at a minimum depth of 5" for ramps, flares and landings, unless otherwise directed.
15. Furnish and install No. 3 reinforcing steel bars at 18" o.c. both ways, unless otherwise directed.
16. Provide a smooth transition where the curb ramps connect to the street.
17. Curbs shown on sheet 1 within the limits of payment are considered part of the curb ramp for payment, whether it is concrete curb, gutter, or combined curb and gutter.
18. Existing features that comply with applicable standards may remain in place unless otherwise shown on the plans.

### DETECTABLE WARNING MATERIAL

19. Curb ramps must contain a detectable warning surface that consists of raised truncated domes complying with PROWAG. The surface must contrast visually with adjoining surfaces, including side flares. Furnish and install an approved cast-in-place dark brown or dark red detectable warning surface material adjacent to uncolored concrete, unless specified elsewhere in the plans.
20. Detectable Warning Materials must meet TxDOT Departmental Materials Specification DMS 4350 and be listed on the Material Producer List. Install products in accordance with manufacturer's specifications.
21. Detectable warning surfaces must be firm, stable and slip resistant.
22. Detectable warning surfaces shall be a minimum of 24 inches in depth in the direction of pedestrian travel, and extend the full width of the curb ramp or landing where the pedestrian access route enters the street.
23. Detectable warning surfaces shall be located so that the edge nearest the curb line is at the back of curb and neither end of that edge is greater than 5 feet from the back of curb. Detectable warning surfaces may be curved along the corner radius.
24. Shaded areas on Sheet 1 of 4 indicate the approximate location for the detectable warning surface for each curb ramp type.

### DETECTABLE WARNING PAVERS (IF USED)

25. Furnish detectable warning paver units meeting all requirements of ASTM C-936, C-33. Lay in a two by two unit basket weave pattern or as directed.
26. Lay full-size units first followed by closure units consisting of at least 25 percent (25%) of a full unit. Cut detectable warning paver units using a power saw.

### SIDEWALKS

27. Provide clear ground space at operable parts, including pedestrian push buttons. Operable parts shall be placed within unobstructed reach range specified in PROWAG section R406.
28. Place traffic signal or illumination poles, ground boxes, controller boxes, signs, drainage facilities and other items so as not to obstruct the pedestrian access route or clear ground space.
29. Street grades and cross slopes shall be as shown elsewhere in the plans.
30. Changes in level greater than 1/4 inch are not permitted.
31. The least possible grade should be used to maximize accessibility. The running slope of sidewalks and crosswalks within the public right of way may follow the grade of the parallel roadway. Where a continuous grade greater than five percent (5%) must be provided, handrails may be desirable to improve accessibility. Handrails may also be needed to protect pedestrians from potentially hazardous conditions. If provided, handrails shall comply with PROWAG R409.
32. Handrail extensions shall not protrude into the usable landing area or into intersecting pedestrian routes.
33. Driveways and turnouts shall be constructed and paid for in accordance with Item "Intersections, Driveways and Turnouts". Sidewalks shall be constructed and paid for in accordance with Item, "Sidewalks".
34. Sidewalk details are shown elsewhere in the plans.

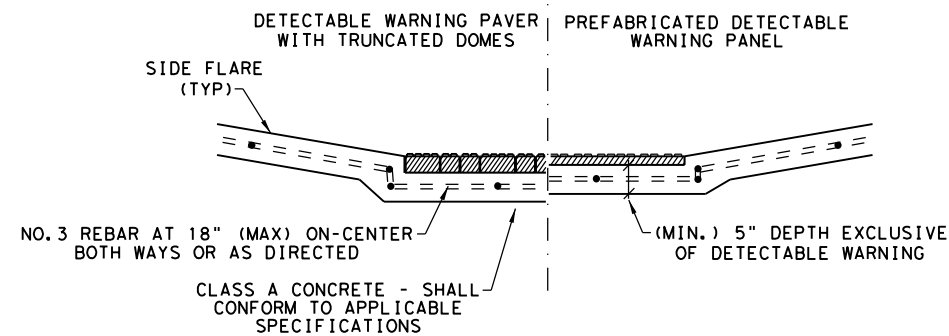

**SECTION VIEW DETAIL**  
**CURB RAMP AT DETECTIBLE WARNINGS**

### DETECTABLE WARNING SURFACE DETAILS

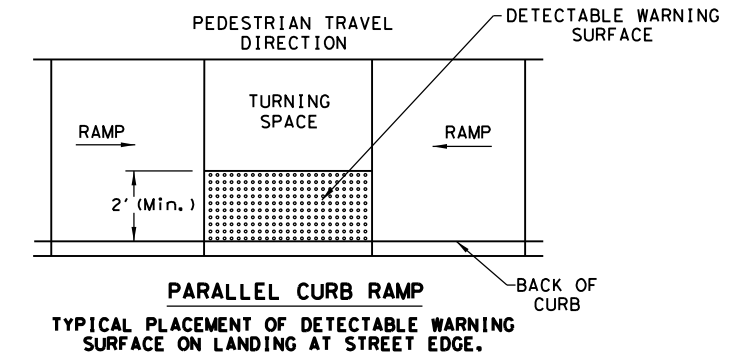

**PARALLEL CURB RAMP**  
**TYPICAL PLACEMENT OF DETECTABLE WARNING SURFACE ON LANDING AT STREET EDGE.**

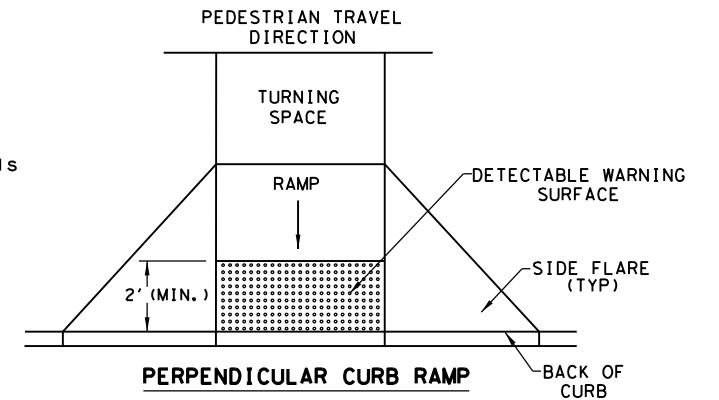

**PERPENDICULAR CURB RAMP**  
**TYPICAL PLACEMENT OF DETECTABLE WARNING SURFACE ON SLOPING RAMP RUN.**

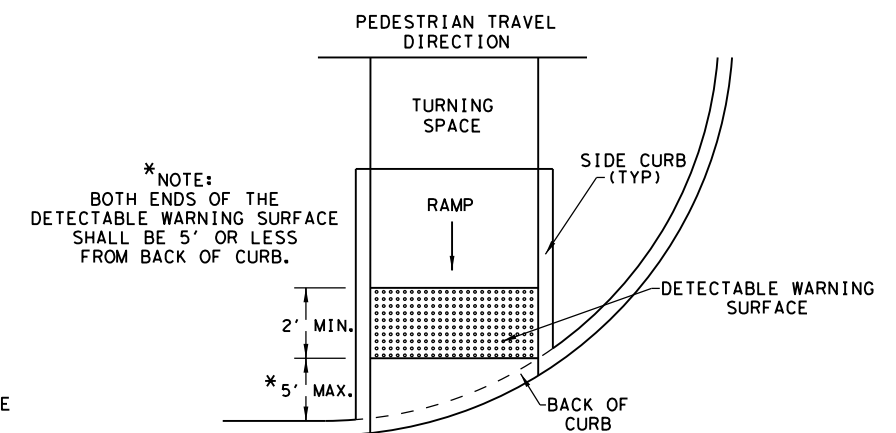

\* NOTE:  
 BOTH ENDS OF THE  
 DETECTABLE WARNING SURFACE  
 SHALL BE 5' OR LESS  
 FROM BACK OF CURB.

**DIRECTIONAL CURB RAMP**  
**TYPICAL PLACEMENT OF DETECTABLE WARNING SURFACE ON SLOPING RAMP RUN.**

SHEET 2 OF 4

Texas Department of Transportation		Design Division Standard	
PEDESTRIAN FACILITIES CURB RAMP			
PED-18			
FILE: ped18	DN: TxDOT	DW: VP	CK: KM
© TxDOT: MARCH, 2002	CON: SECT	JOB	HIGHWAY
REVISIONS	0918 00	392	VA
REVISED 08, 2005	DIST	COUNTY	SHEET NO.
REVISED 06, 2012	DAL	DALLAS, ETC	25
REVISED 01, 2018			

DISCLAIMER: The use of this standard is governed by the "Texas Engineering Practice Act". No warranty of any kind is made by TxDOT for any purpose whatsoever. TxDOT assumes no responsibility for the conversion of this standard to other formats or for incorrect results or damages resulting from its use.

**SIDEWALK TREATMENT AT DRIVEWAYS**

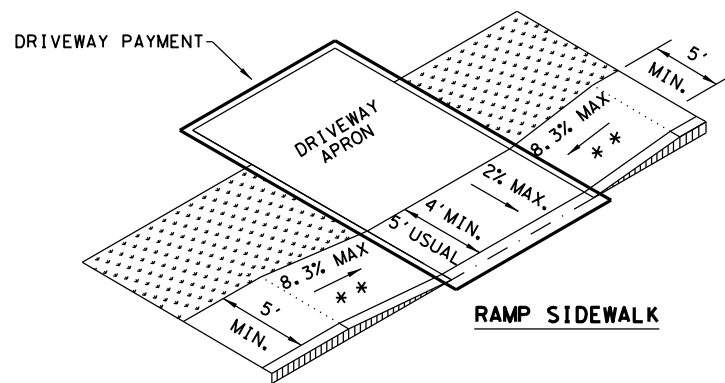
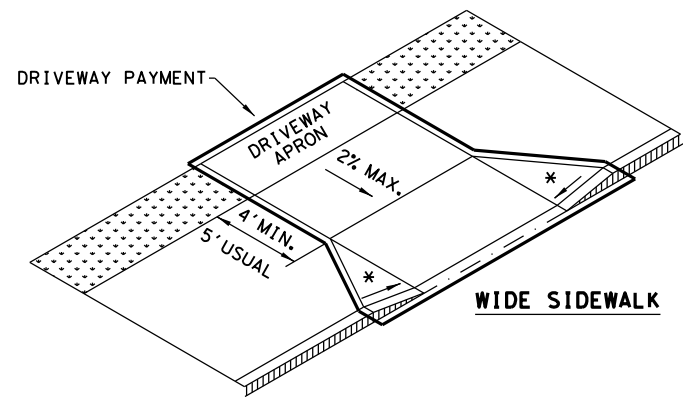
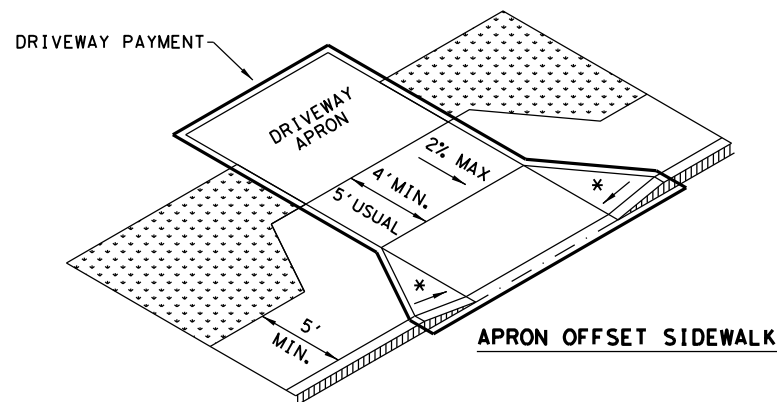
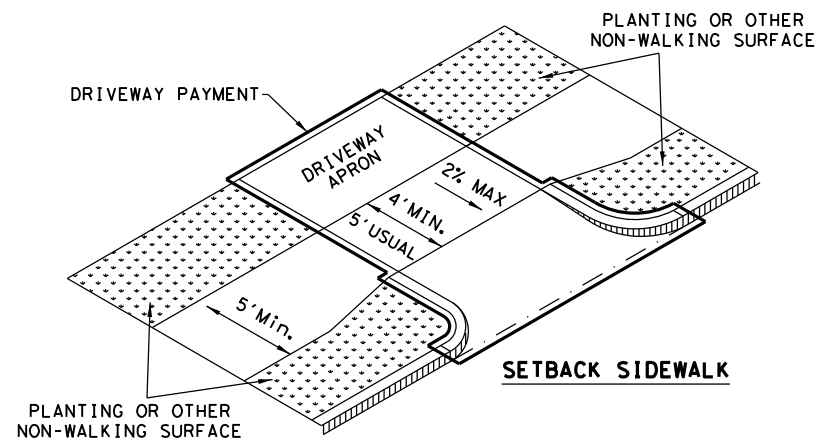

NOTES:  
 \* WHERE DRIVEWAYS CROSS THE PEDESTRIAN ROUTE, SIDES SHALL BE FLARED AT 10% MAX SLOPE.  
 \*\* IF CURB HEIGHT IS GREATER THAN 6 INCHES, USE GRADE LESS THAN OR EQUAL TO 5%. HANDRAIL AND DETECTABLE WARNING ARE NOT REQUIRED.

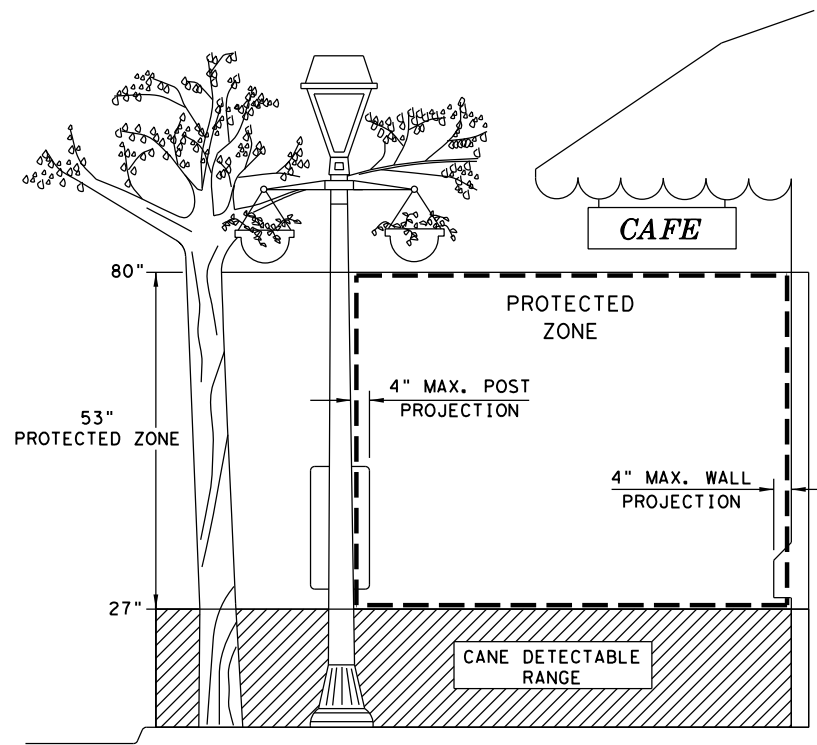

NOTE: IN PEDESTRIAN CIRCULATION AREA, MAXIMUM 4" PROJECTION FOR POST OR WALL MOUNTED OBJECTS BETWEEN 27" AND 80" ABOVE THE SURFACE.

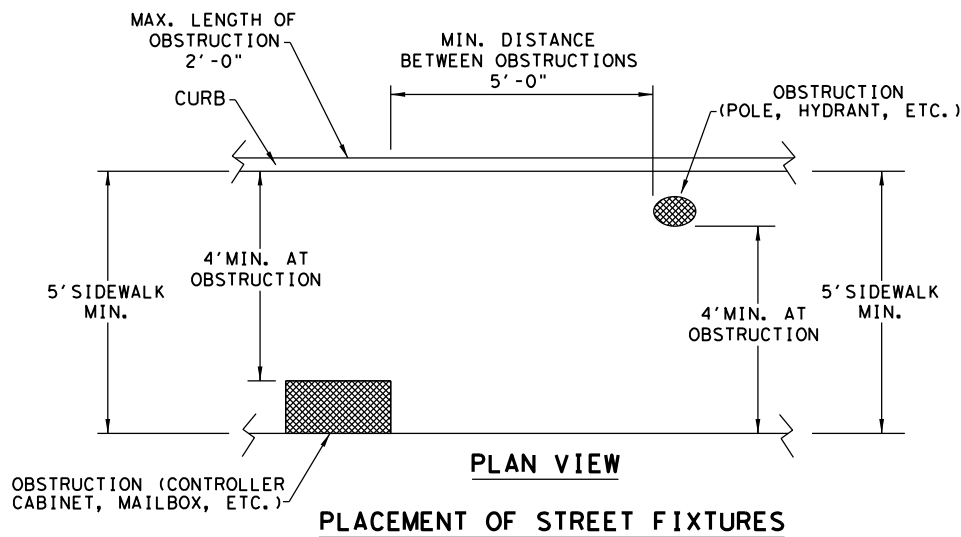
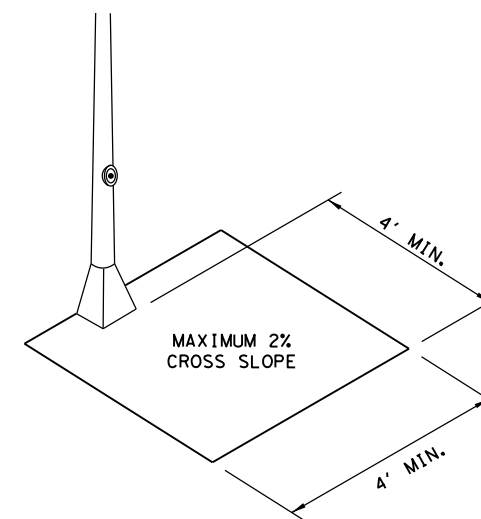

NOTE: ITEMS NOT INTENDED FOR PUBLIC USE. MINIMUM 4' X 4' CLEAR GROUND SPACE REQUIRED AT PUBLIC USE FIXTURES.

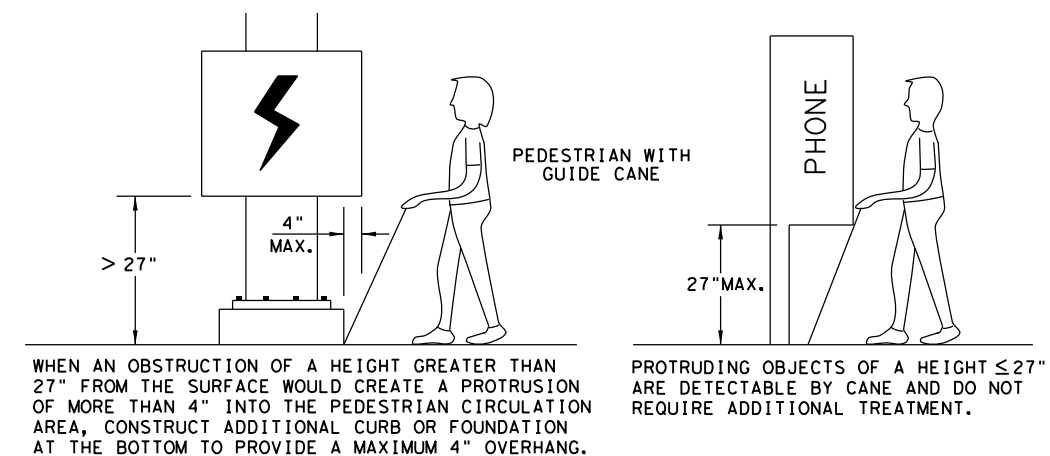

SHEET 3 OF 4

Texas Department of Transportation  
 Design Division Standard

**PEDESTRIAN FACILITIES  
 CURB RAMPS**

**PED-18**

FILE: ped18	DN: TxDOT	DW: VP	CK: KM	CK: PK & JG
© TxDOT: MARCH, 2002	CONT	SECT	JOB	HIGHWAY
REVISIONS	0918	00	392	VA
REVISED 08, 2005	DIST	COUNTY	SHEET NO.	
REVISED 06, 2012	DAL	DALLAS, ETC	26	
REVISED 01, 2018				

DATE:  
 FILE:

DISCLAIMER: The use of this standard is governed by the "Texas Engineering Practice Act". No warranty of any kind is made by TxDOT for any purpose whatsoever. TxDOT assumes no responsibility for the conversion of this standard to other formats or for incorrect results or damages resulting from its use.

TYPICAL CROSSING LAYOUTS  
SEE SHEET 1 OF 4 FOR DETAILS AND DIMENSIONS

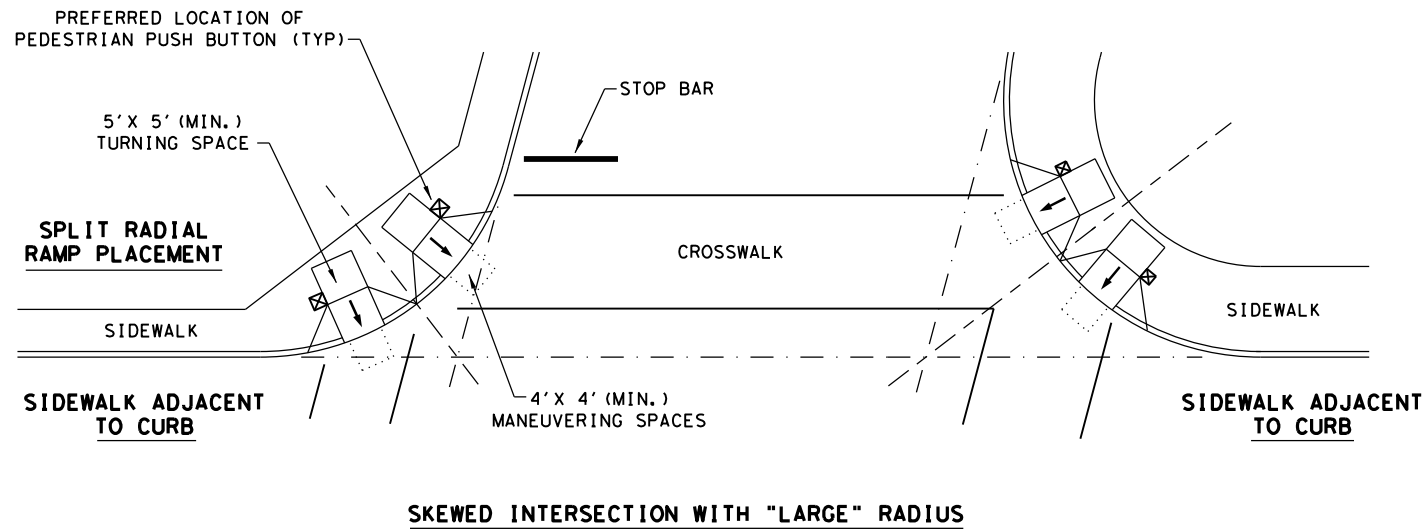

SKewed INTERSECTION WITH "LARGE" RADIUS

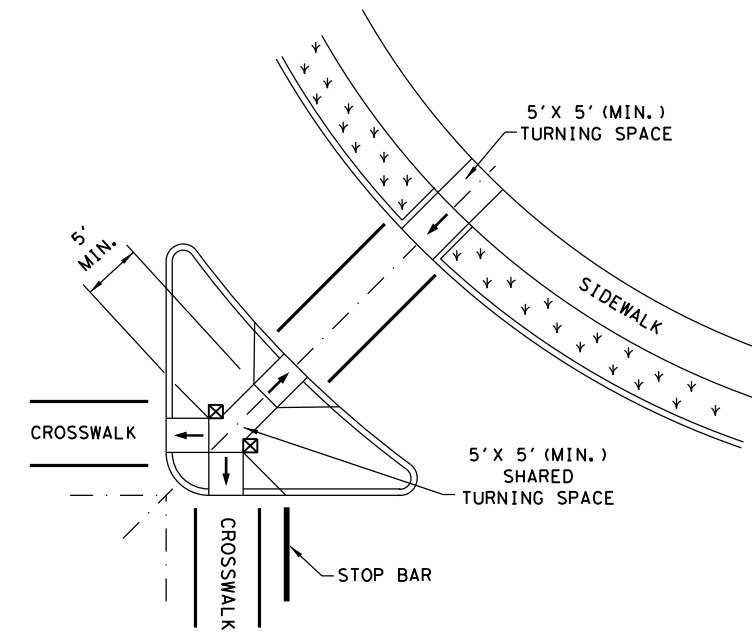

AT INTERSECTION  
W/FREE RIGHT TURN & ISLAND

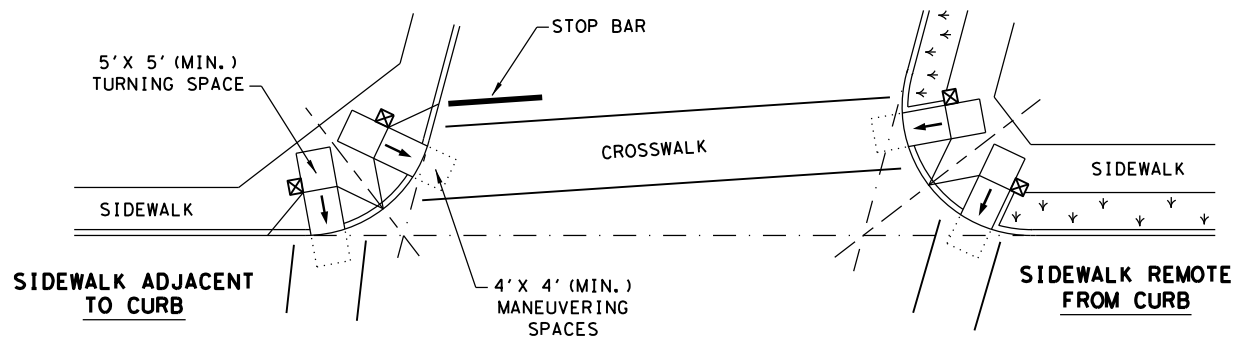

SKewed INTERSECTION WITH "SMALL" RADIUS

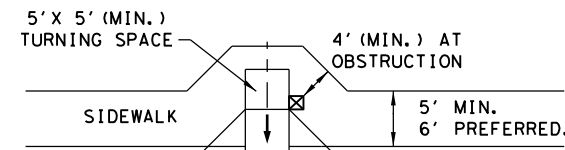

SIDEWALK ADJACENT TO CURB

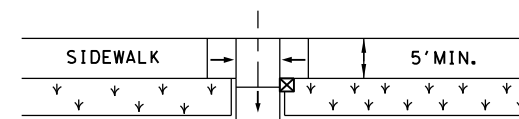

SIDEWALK REMOTE FROM CURB

MID-BLOCK PLACEMENT  
PERPENDICULAR RAMPS

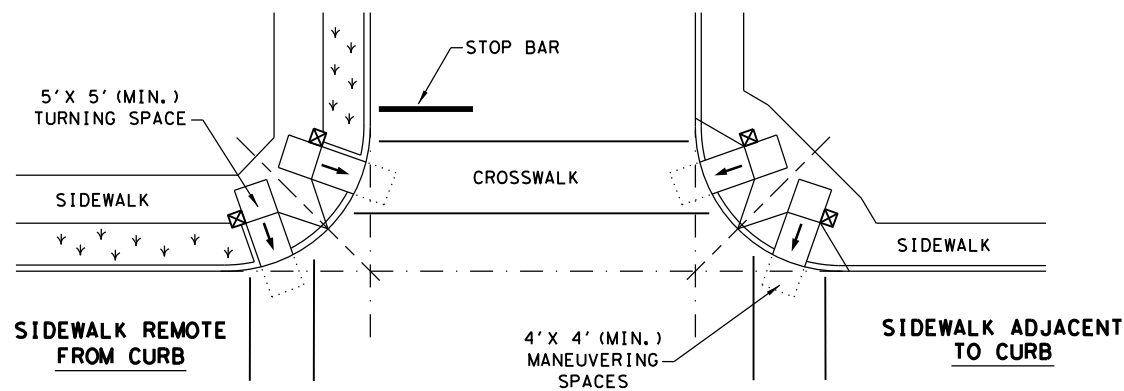

NORMAL INTERSECTION WITH "SMALL" RADIUS

LEGEND:

SHOWS DOWNWARD SLOPE. →

DENOTES PREFERRED LOCATION OF PEDESTRIAN PUSH BUTTON (IF APPLICABLE). ☒

DENOTES PLANTING OR NON-WALKING SURFACE NOT PART OF PEDESTRIAN CIRCULATION PATH. ↙ ↘ ↙ ↘ ↙ ↘

SHEET 4 OF 4



Design  
Division  
Standard

PEDESTRIAN FACILITIES  
CURB RAMPS

PED-18

FILE: ped18	DN: TxDOT	DW: VP	CK: KM	CK: PK & JG
© TxDOT: MARCH, 2002	CONT	SECT	JOB	HIGHWAY
REVISIONS	0918	00	392	VA
REVISED 08, 2005	DIST	COUNTY		SHEET NO.
REVISED 06, 2012	DAL	DALLAS, ETC		27
REVISED 01, 2018				

DATE:  
FILE:

DISCLAIMER: The use of this standard is governed by the "Texas Engineering Practice Act". No warranty of any kind is made by TxDOT for any purpose whatsoever. TxDOT assumes no responsibility for the conversion of this standard to other formats or for incorrect results or damages resulting from its use.

DATE:  
FILE:

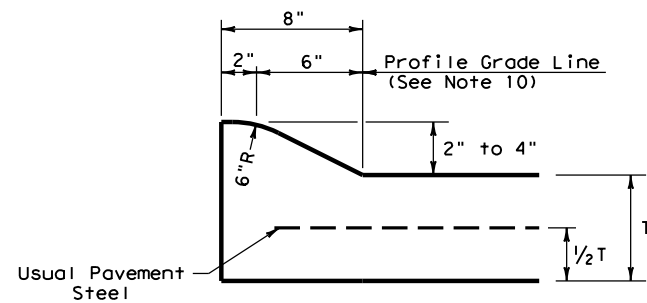

**TYPE I CURB (MONOLITHIC)  
2" - 4" HEIGHT**

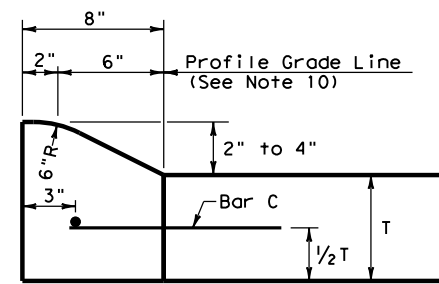

**TYPE I CURB  
2" - 4" HEIGHT**

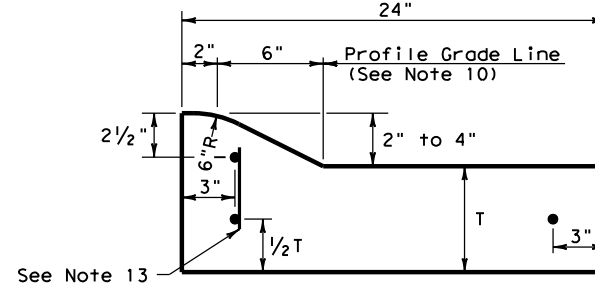

**TYPE I CURB AND GUTTER  
2" - 4" HEIGHT**

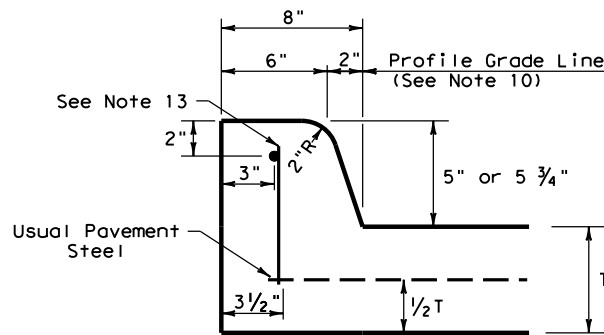

**TYPE II CURB (MONOLITHIC)  
5" - 5 3/4" HEIGHT**

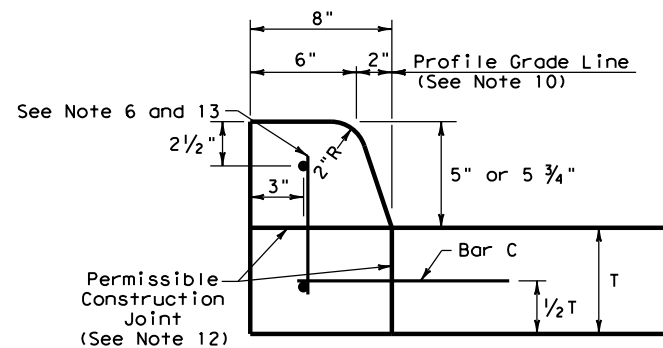

**TYPE II CURB  
5" - 5 3/4" HEIGHT**

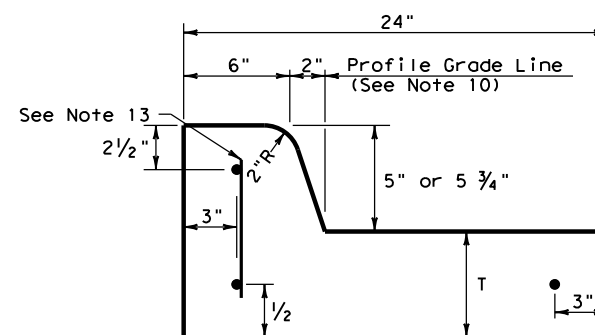

**TYPE II CURB AND GUTTER  
5" - 5 3/4" HEIGHT**

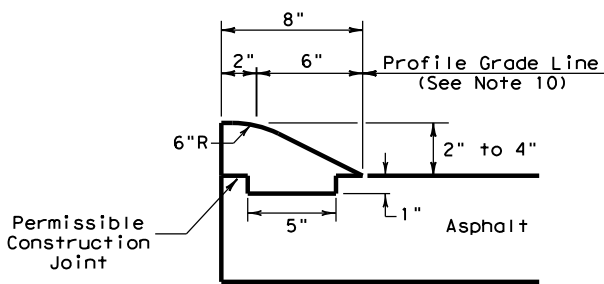

**TYPE III CURB (KEYED)  
2" - 4" HEIGHT**

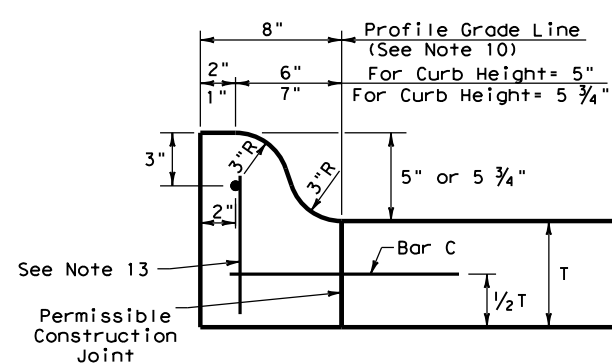

**TYPE IIa CURB  
5" - 5 3/4" HEIGHT**

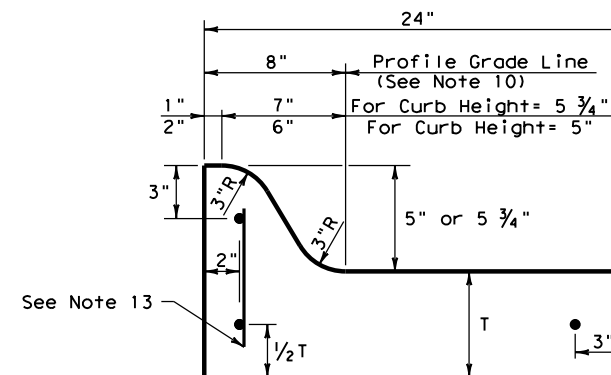

**TYPE IIa CURB AND GUTTER  
5" - 5 3/4" HEIGHT**

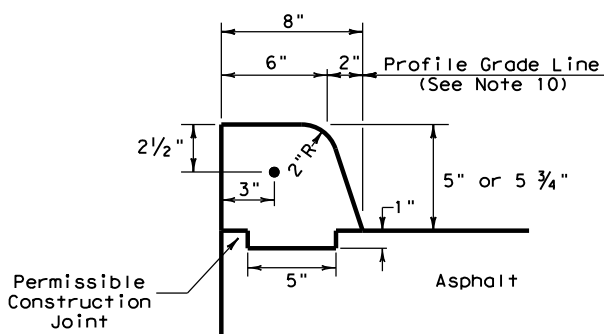

**TYPE IV CURB (KEYED)  
5" - 5 3/4" HEIGHT**

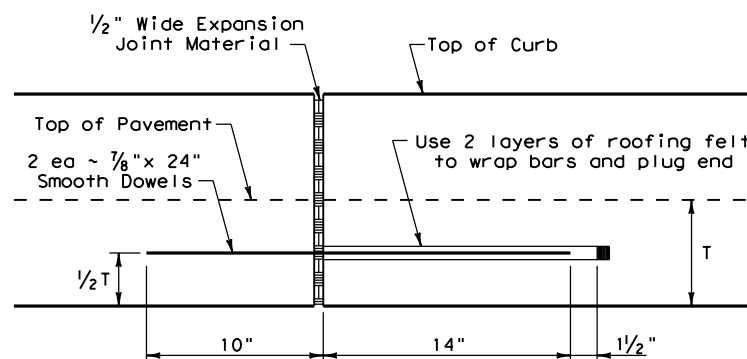

**EXPANSION JOINT DETAIL**

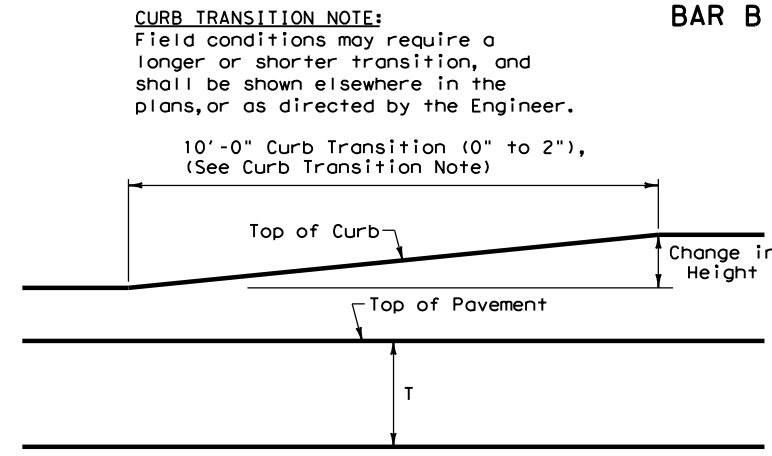

**CURB TRANSITION**

Note: To be paid for as Highest Curb

**GENERAL NOTES**

- All materials and construction shall be in accordance with Item 529, "Concrete Curb, Gutter, and Combined Curb and Gutter."
- Concrete shall be Class A.
- When reinforcing bars are used, they shall be No.4 unless otherwise shown. The use of fiber reinforced concrete in lieu of reinforcing steel is acceptable. Use fibers meeting the requirements of DMS 4550, "Fibers for Concrete," and dose fibers in accordance with Material Producers List (MPL) "Fibers for Class A and B Concrete Applications."
- Round exposed sharp edges with a rounding tool, to a minimum radius of 1/4 inch.
- All existing curbs and driveways to be removed shall be sawed or removed at existing joints.
- Where concrete curb is to be placed on existing concrete pavement, Bar B may be drilled and grouted in place, or may be inserted into fresh concrete.
- Expansion and contraction joints shall be constructed to match pavement joints in all curbs and curb and gutter adjacent to jointed concrete pavement. Where placement of curb or curb and gutter is not adjacent to concrete pavement, expansion joints shall be provided at structures, curb returns at streets, and at locations directed by The Engineer.
- Vertical and horizontal dowel bars and transverse reinforcing bars shall be placed at four feet C-C.
- Dimension 'T' shown is the thickness of concrete pavement. When curb is installed adjacent to flexible pavement dimension 'T' is 8" maximum.
- Usual profile grade line. Refer to typical sections and plan-profile sheets for exact locations.
- One-half inch expansion joint material shall be provided where curb or curb and gutter is adjacent to sidewalk or riprap.
- When horizontal permissible construction joints are used, the longitudinal pavement steel shall be placed in accordance with pavement details shown elsewhere in the plans. Reinforcing steel for curb section shall then conform to that required for concrete curb.
- Bar B placement as needed (typically at four ft. C-C) to support curb reinforcing steel during concrete placement.

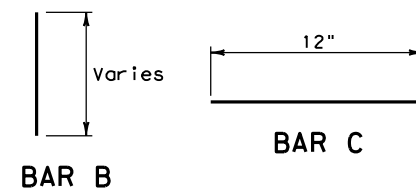

**CURB TRANSITION NOTE:**  
Field conditions may require a longer or shorter transition, and shall be shown elsewhere in the plans, or as directed by the Engineer.

		<b>Design Division Standard</b>	
<b>CONCRETE CURB AND GUTTER</b>			
<b>CCCG-22</b>			
FILE: cccg21.dgn	DN: TxDOT	CK: AN	DW: CS
© TxDOT: JUNE 2022	CONT: 0918	SECT: 00	JOB: 392
REVISIONS	DIST: DAL	COUNTY: DALLAS, ETC	SHEET NO.: 28

DATE: 2/13/2024  
 FILE: U:\TRAFFIC PROJECTS\0918-00-392 Non-Site 9-24\Microstation Files\029-030 REPCP-14.dgn  
 DISCLAIMER: The use of this standard is governed by the "Texas Engineering Practice Act". No warranty of any kind is made by TxDOT for any purpose whatsoever. TxDOT assumes no responsibility for the conversion of this standard to other formats or for incorrect results or damages resulting from its use.

TABLE NO.1 STEEL BAR SIZE AND SPACING						
TYPE PAVEMENT	SLAB THICKNESS AND BAR SIZE		LONGITUDINAL*		TRANSVERSE*	
	T (IN.)	BAR SIZE	REGULAR BARS	TIEBARS	BARS	TIEBARS
			SPACING (IN.)	SPACING (IN.)	SPACING (IN.)	SPACING (IN.)
CRCP	6.0	#5	7.5	7.5	24	24
	6.5		7.0	7.0		
	7.0		6.5	6.5		
	7.5		6.0	6.0		
	8.0	#6	9.0	9.0	24	24
	8.5		8.5	8.5		
	9.0		8.0	8.0		
	9.5		7.5	7.5		
	10.0		7.0	7.0		
	10.5		6.75	6.75		
11.0	6.5	6.5				
11.5	6.25	6.25				
≥12.0	6.0	6.0				
JRCP	<8.0	#5	24.0	12.0	24	24
	≥8.0	#6	24.0	12.0	24	24
CPCD	<8.0	#5	NONE	12.0	NONE	24
	≥8.0	#6	NONE	12.0	NONE	24

\* USE 12" SPACING AS FIRST AND LAST SPACING AT END OR SIDE FOR ALL BARS.

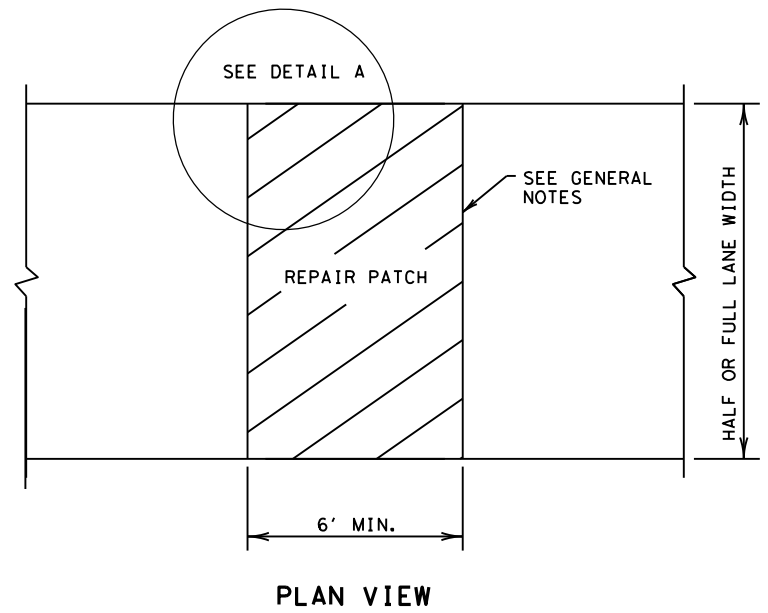

PLAN VIEW

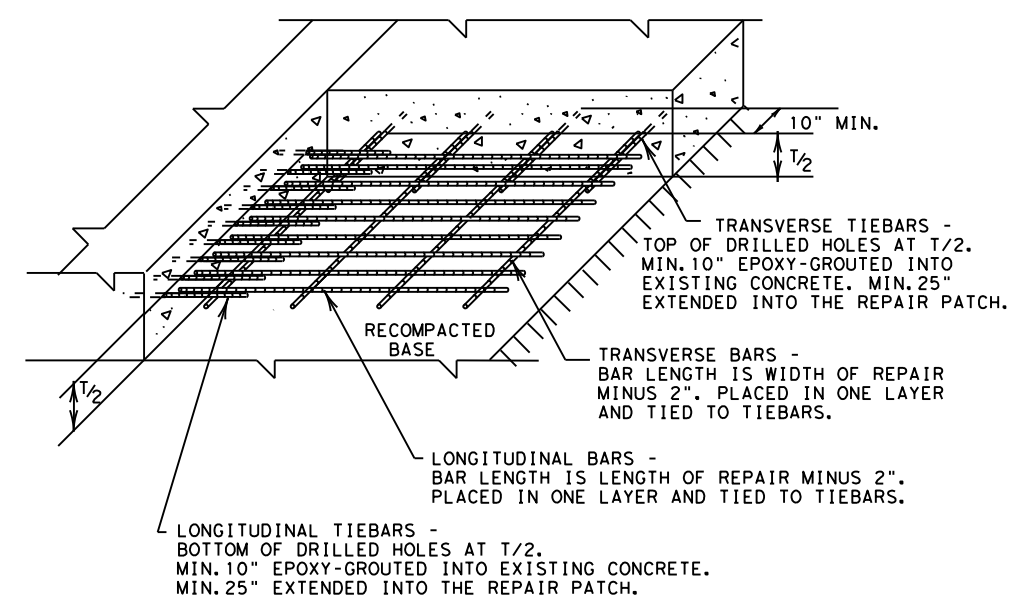

DETAIL A  
GROUTED TIEBARS & REINFORCEMENT

FULL-DEPTH REPAIR OF CRCP, JRCP, AND CPCD

GENERAL NOTES

- ITEM 361, "REPAIR OF CONCRETE PAVEMENT" SHALL GOVERN FOR THIS WORK.
- MULTIPLE PIECE TIEBARS SHALL BE USED WHEN THE REPAIR AREA MUST BE PLACED IN TWO STAGES DUE TO SEQUENCE OF CONSTRUCTION.
- FULL DEPTH SAW CUTS SHALL BE MADE AROUND THE PERIMETER OF THE AREA TO BE REPAIRED. THE CUT SHALL BE MADE AT A RIGHT ANGLE TO THE PAVEMENT EDGE AND TO THE CENTER LINE OF THE PAVEMENT.
- AT LEAST ONE LONGITUDINAL FULL DEPTH SAW CUT SHALL BE AT AN EXISTING LONGITUDINAL JOINT.
- ADDITIONAL SAW CUTS MAY BE REQUIRED WITHIN THE AREA OF THE REPAIR TO FACILITATE REMOVAL OF THE CONCRETE OR TO ALLEVIATE BINDING OF THE FULL DEPTH SAW CUT AT THE REPAIR EDGE.
- THE SAW CUTS WHICH EXTEND OUTSIDE THE AREA OF THE REPAIR WILL BE CLEANED AND FILLED WITH A CEMENTITIOUS GROUT APPROVED BY THE ENGINEER.
- EXISTING LONGITUDINAL AND TRANSVERSE JOINTS REMOVED DUE TO REPAIR OPERATION SHOULD BE RESTORED IN ACCORDANCE WITH STANDARD SHEET "CONCRETE PAVING DETAILS, JOINT SEALS."

GENERAL NOTES

- ITEM 361, "REPAIR OF CONCRETE PAVEMENT" SHALL GOVERN FOR THIS WORK.
- THE SAW CUTS WHICH EXTEND OUTSIDE THE AREA OF THE REPAIR WILL BE CLEANED AND FILLED WITH A CEMENTITIOUS GROUT APPROVED BY THE ENGINEER.
- EXISTING LONGITUDINAL AND TRANSVERSE JOINTS REMOVED DUE TO REPAIR OPERATION SHOULD BE RESTORED IN ACCORDANCE WITH STANDARD SHEET "CONCRETE PAVING DETAILS, JOINT SEALS."

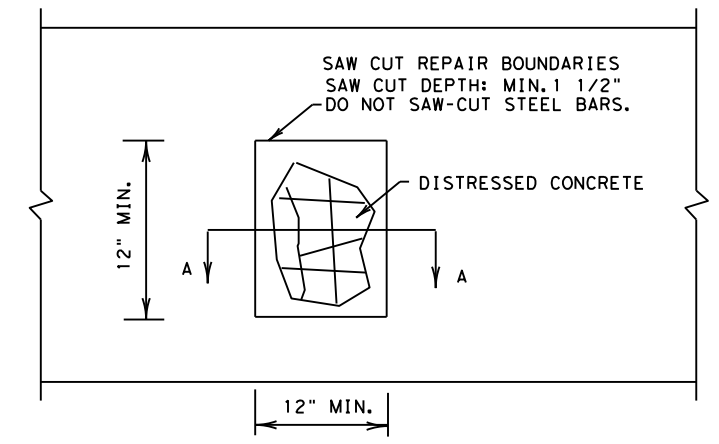

PLAN VIEW

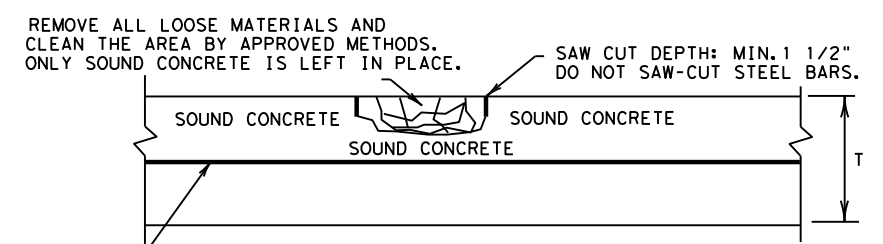

LONGITUDINAL STEEL BARS:  
 \*REPAIR AREAS MAY BE ADJUSTED AFTER REMOVING DISTRESSED CONCRETE. SWITCH THE HALF-DEPTH REPAIR TO FULL-DEPTH REPAIR IF EXPOSED EXISTING LONGITUDINAL BARS ARE DEFICIENT, AS APPROVED. COMPENSATION WILL BE MADE FOR UNEXPECTED VOLUMES OF REPAIR AREAS OR CHANGES IN SCOPE OF WORK.  
 \*INCREASE THE REPAIR AREA AND PERFORM A FULL-DEPTH REPAIR AS DIRECTED IF LONGITUDINAL STEEL BARS WERE DAMAGED BY THE REMOVAL OPERATIONS. NO ADDITIONAL COMPENSATION WILL BE MADE.

SECTION A-A  
HALF-DEPTH REPAIR

SHEET 1 OF 2

				Design Division Standard	
<h2>REPAIR OF CONCRETE PAVEMENT</h2> <h3>REPCP-14</h3>					
FILE: repcp14.dgn	DN: TxDOT	DN: HC	DW: HC	CK: AN	
© TxDOT: DECEMBER 2014	CONT	SECT	JOB	HIGHWAY	
REVISIONS	0918	00	392	VA	
	DIST	COUNTY	SHEET NO.		
	DAL	DALLAS, ETC.	29		

DISCLAIMER:  
 The use of this standard is governed by the "Texas Engineering Practice Act". No warranty of any kind is made by TxDOT for any purpose whatsoever.  
 TxDOT assumes no responsibility for the conversion of this standard to other formats or for incorrect results or damages resulting from its use.

DATE: 2/13/2024  
 FILE: U:\TRAFFIC PROJECTS\0918-00-392 Non-Site 9-24\Microstation Files\029-030 REPCP-14.dgn

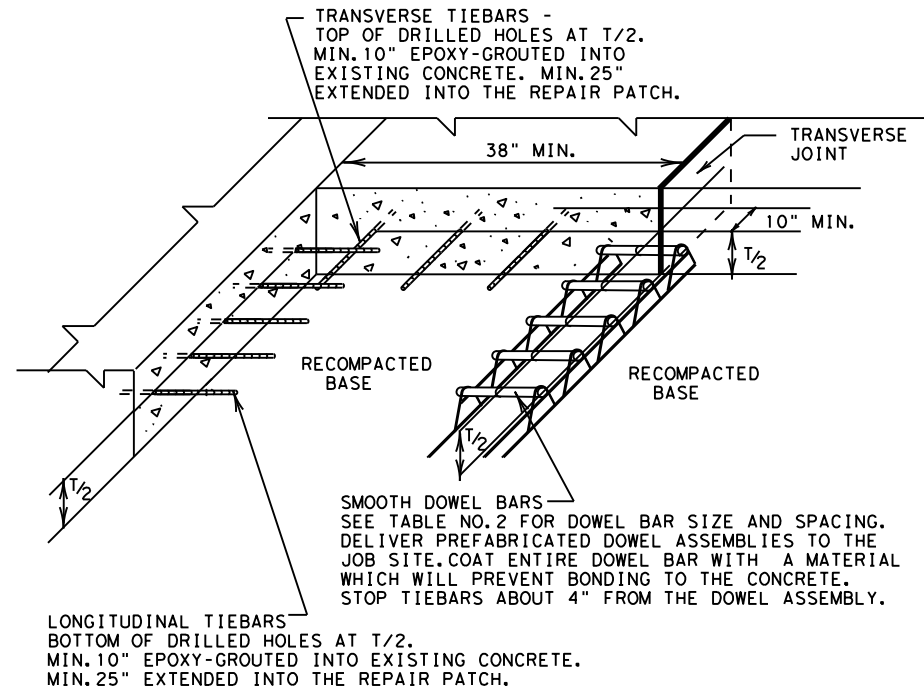
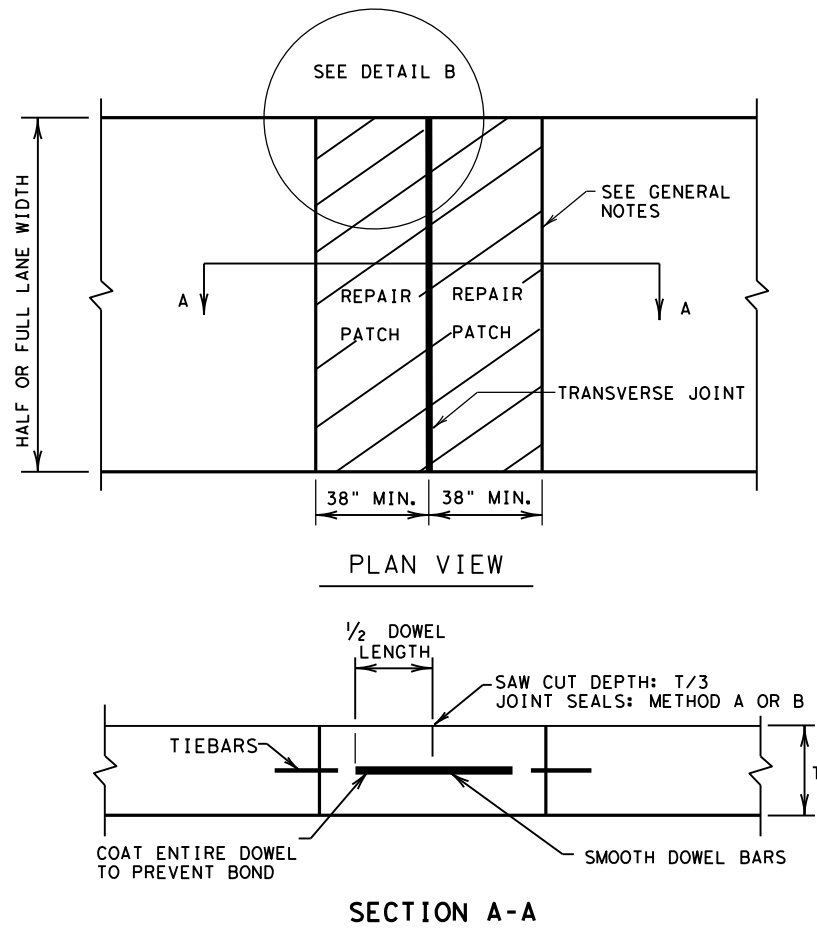

**DETAIL B**  
**GROUTED TIEBARS & DOWELS**

**REPAIR OF TRANSVERSE JOINT OF CPCD**

**GENERAL NOTES**

1. ITEM 361, "REPAIR OF CONCRETE PAVEMENT" SHALL GOVERN FOR THIS WORK.
2. MULTIPLE PIECE TIEBARS SHALL BE USED WHEN THE REPAIR AREA MUST BE PLACED IN TWO STAGES DUE TO SEQUENCE OF CONSTRUCTION.
3. FULL DEPTH SAW CUTS SHALL BE MADE AROUND THE PERIMETER OF THE AREA TO BE REPAIRED. THE CUT SHALL BE MADE AT A RIGHT ANGLE TO THE PAVEMENT EDGE AND TO THE CENTER LINE OF THE PAVEMENT.
4. AT LEAST ONE LONGITUDINAL FULL DEPTH SAW CUT SHALL BE AT AN EXISTING LONGITUDINAL JOINT.
5. ADDITIONAL SAW CUTS MAY BE REQUIRED WITHIN THE AREA OF THE REPAIR TO FACILITATE REMOVAL OF THE CONCRETE OR TO ALLEVIATE BINDING OF THE FULL DEPTH SAW CUT AT THE REPAIR EDGE.
6. THE SAW CUTS WHICH EXTEND OUTSIDE THE AREA OF THE REPAIR WILL BE CLEANED AND FILLED WITH A CEMENTITIOUS GROUT APPROVED BY THE ENGINEER.
7. EXISTING LONGITUDINAL AND TRANSVERSE JOINTS REMOVED DUE TO REPAIR OPERATION SHOULD BE RESTORED IN ACCORDANCE WITH STANDARD SHEET "CONCRETE PAVING DETAILS, JOINT SEALS."
8. DOWEL BAR PLACEMENT TOLERANCE SHALL BE +/- 1/4 IN. HORIZONTALLY AND VERTICALLY UNLESS OTHERWISE SPECIFIED. WHERE DOWEL BAR BASKETS ARE USED, REMOVE THE SHIPPING WIRES.

PAVEMENT THICKNESS (INCHES)	SIZE AND DIA.	LENGTH (IN.)	SPACING (IN.)
<10	#8 (1 IN.)	18.0	12.0
≥10	#10 (1 1/4 IN.)		

SHEET 2 OF 2



**REPAIR OF CONCRETE PAVEMENT**

**REPCP-14**

FILE: repcp14.dgn	DN: TxDOT	DN: HC	DW: HC	CK: AN
© TxDOT: DECEMBER 2014	CONT	SECT	JOB	HIGHWAY
REVISIONS	0918	00	392	VA
	DIST	COUNTY		SHEET NO.
	DAL	DALLAS, ETC.		30

DISCLAIMER: The use of this standard is governed by the "Texas Engineering Practice Act". No warranty of any kind is made by TxDOT for any purpose whatsoever. TxDOT assumes no responsibility for the conversion of this standard to other formats or for incorrect results or damages resulting from its use.

DATE: 2/13/2024 3:29:58 PM  
 U:\TRAFFIC PROJECTS\0918-00-392 Non-Site 9-24\Microstation Files\031 JS-14.dgn

### METHOD B: JOINT SEALING COMPOUND

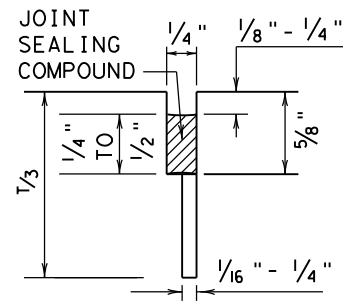

LONGITUDINAL SAWED CONTRACTION JOINT

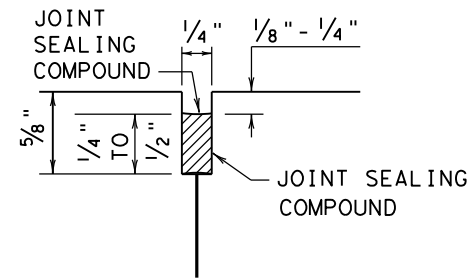

LONGITUDINAL OR TRANSVERSE CONSTRUCTION JOINT

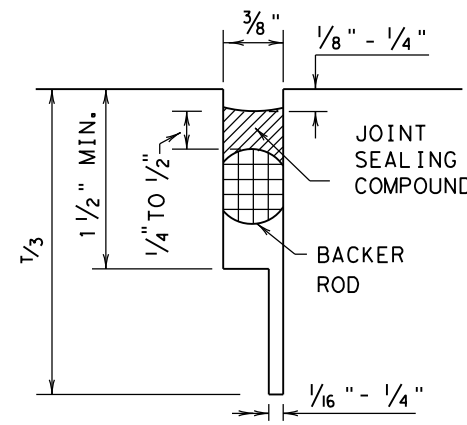

TRANSVERSE SAWED CONTRACTION JOINT

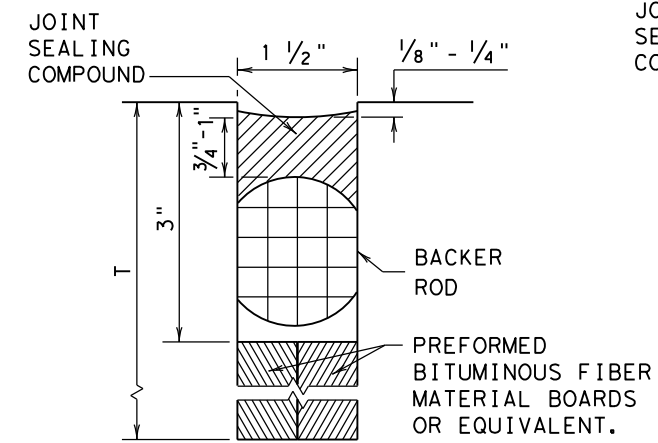

TRANSVERSE FORMED EXPANSION JOINT

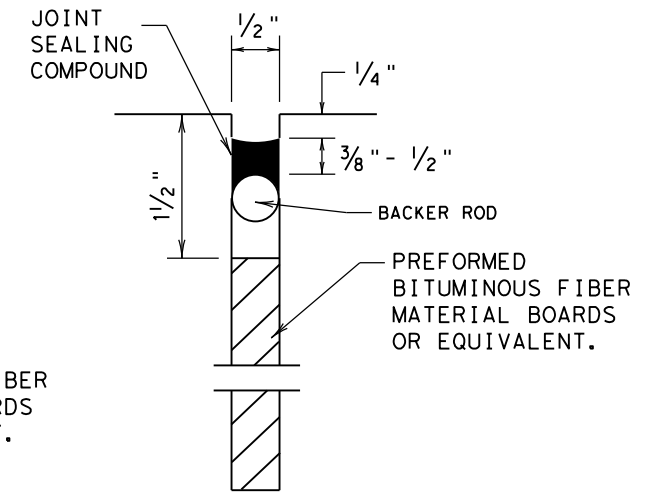

FORMED ISOLATION JOINT

### METHOD A: PREFORMED COMPRESSION SEALS (PCS) (DMS-6310 CLASS 6)

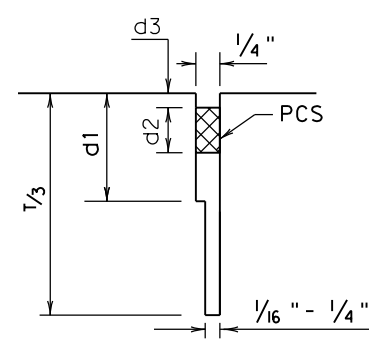

LONGITUDINAL SAWED CONTRACTION JOINT

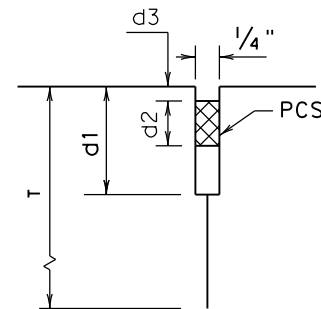

LONGITUDINAL CONSTRUCTION JOINT

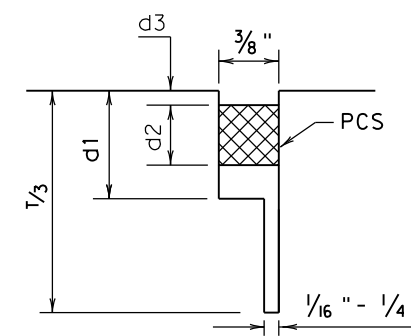

TRANSVERSE SAWED CONTRACTION JOINT

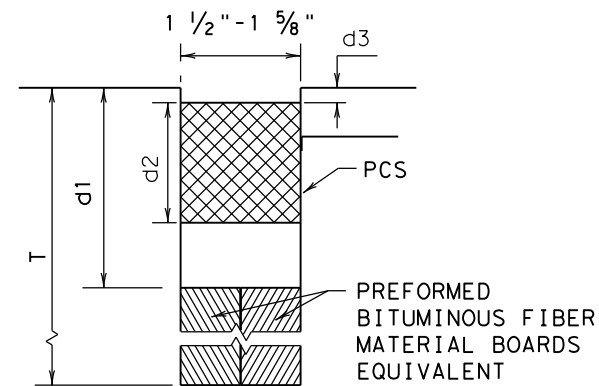

TRANSVERSE FORMED EXPANSION JOINT

### GENERAL NOTES

- UNLESS OTHERWISE SHOWN IN THE PLANS, EITHER METHOD "A" OR METHOD "B" MAY BE USED.
- THE LOCATION OF JOINTS SHALL BE AS SHOWN ELSEWHERE IN THE PLANS.
- THE JOINT RESERVOIR FOR SEALANT OR PCS SHALL BE SAWED UNLESS OTHERWISE SHOWN ON THE PLANS FOR THE LONGITUDINAL AND TRANSVERSE CONSTRUCTION JOINTS AND THE SAWED JOINTS.
- DIMENSIONS d1, d2, AND d3 SHOWN IN METHOD A SHALL BE IN ACCORDANCE WITH THE PREFORMED COMPRESSION SEAL MANUFACTURER'S RECOMMENDATION.
- REFER TO DMS-6310 "JOINT SEALANTS AND FILLERS" FOR THE CLASSIFICATIONS.
- FOR SAWED LONGITUDINAL JOINT, LONGITUDINAL OR TRANSVERSE CONSTRUCTION JOINT, USE JOINT SEALANT CLASS 5 OR 8 UNLESS OTHERWISE SHOWN ON THE PLAN OR APPROVED.
- FOR TRANSVERSE SAWED CONTRACTION, TRANSVERSE FORMED EXPANSION JOINT, AND ISOLATION JOINT USE JOINT SEALANT CLASS 5 OR 8 AT NEW JOINTS. USE JOINT SEALANT CLASS 4, 5, 7, OR 8 FOR MAINTAINING EXISTING JOINTS.
- THE JOINTS SHALL BE CLEANED IN ACCORDANCE WITH THE ITEM 438 "CLEANING AND SEALING JOINTS" OR ITEM 713 "CLEANING AND SEALING JOINTS AND CRACKS (CONCRETE PAVEMENT)".
- ISOLATION JOINTS ACCOMMODATE HORIZONTAL AND VERTICAL MOVEMENTS THAT OCCUR BETWEEN A PAVEMENT AND A STRUCTURE. ISOLATION JOINTS MAY BE USED FOR BRIDGE ABUTMENTS, INTERSECTIONS, CURB AND GUTTER, OLD AND NEW PAVEMENTS, OR AROUND DRAINAGE INLETS, MANHOLES, FOOTINGS AND LIGHTING STRUCTURES.

		Design Division Standard	
<b>CONCRETE PAVING DETAILS</b> <b>JOINT SEALS</b> <b>JS-14</b>			
FILE: js14.dgn	DN: TxDOT	DN: HC	CK: AN
© TxDOT: DECEMBER 2014	CONT	SECT	HIGHWAY
REVISIONS	0918 00	392	VA
DIST	COUNTY	SHEET NO.	
DAL	DALLAS, ETC.	31	

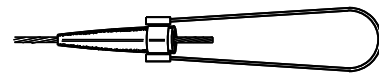

### COMPRESSION FITTING

SOURCES:  
RELIABLE ELECTRIC NO. 5264  
FARGO NO. OR EQUAL

MINIMUM 1" SEPARATION FROM  
SIGNAL HEAD MOUNTING BRACKET

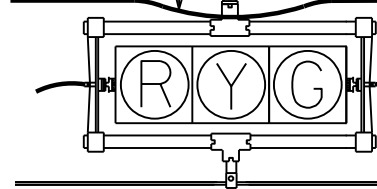

1/4" STRANDED STEEL CABLE

1/2" BLACK PLASTIC CABLE STRAPS OR  
MESSENGER RINGS AT 12" CTRS.

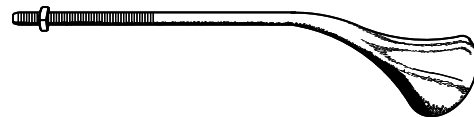

### THIMBLEYE BOLT (Angle Type)

SOURCES:  
HUBBELL POWER SYS. NO. 5016  
MCLEAN POWER SYS. NO. J8154  
OR EQUAL

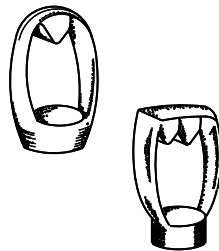

### EYE NUTS (Twineye & tripeye)

SOURCES:  
HUBBELL POWER SYS. NO. 6560 (TWIN), 6510 (SINGLE)  
MCLEAN POWER SYS. NO. J6515 (TWIN), J6510 (SINGLE)  
OR EQUAL

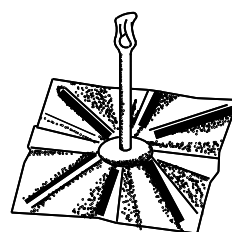
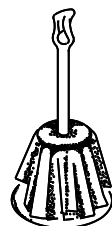

### 8-WAY ANCHOR

SOURCES:  
HUBBELL POWER SYS. NO. 1283  
MCLEAN POWER SYS. NO. J0283  
OR EQUAL

### LIFT PLATE

SOURCES:  
HUBBELL POWER SYS. NO. 7898  
MCLEAN POWER SYS. NO. J7890  
OR EQUAL

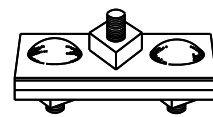

### GUY CLAMP (3-Bolt)

6" HEAVY GUY CLAMP WITH 3-5/8"  
BOLTS OR RELIABLE ELECTRIC  
STRANDWISE WITH FLEXIBLE BAIL  
(NO. 5264), FARGO STRANDWISE,  
HUBBELL POWER SYS. NO. 6460,  
OR EQUAL

PENTACHLOROPHENOL TREATED  
40' SOUTHERN YELLOW PINE POLE  
(CLASS 2)

HOLE DIA = POLE DIA  
AT BOTTOM + 18"

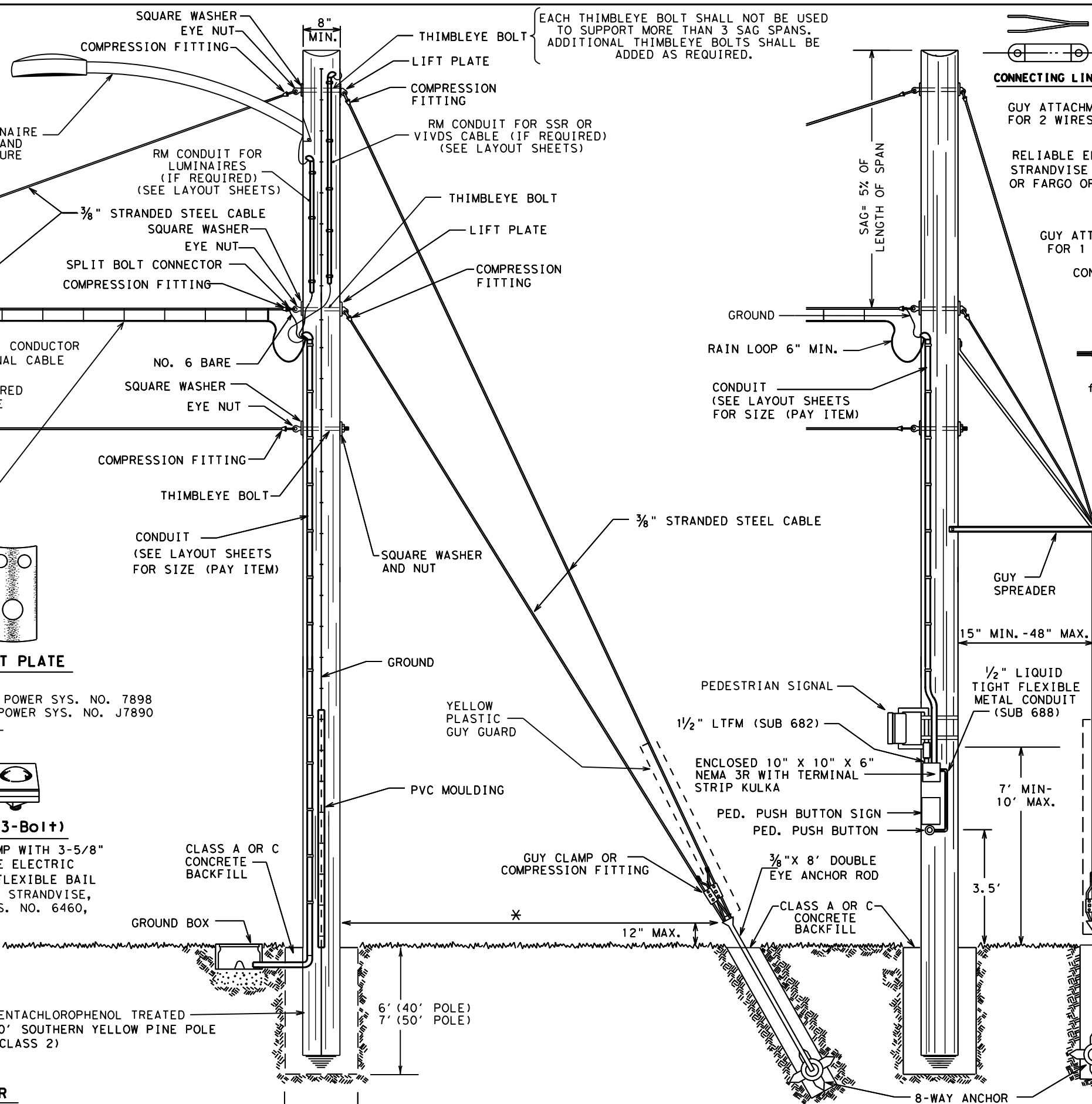

EACH THIMBLEYE BOLT SHALL NOT BE USED  
TO SUPPORT MORE THAN 3 SAG SPANS.  
ADDITIONAL THIMBLEYE BOLTS SHALL BE  
ADDED AS REQUIRED.

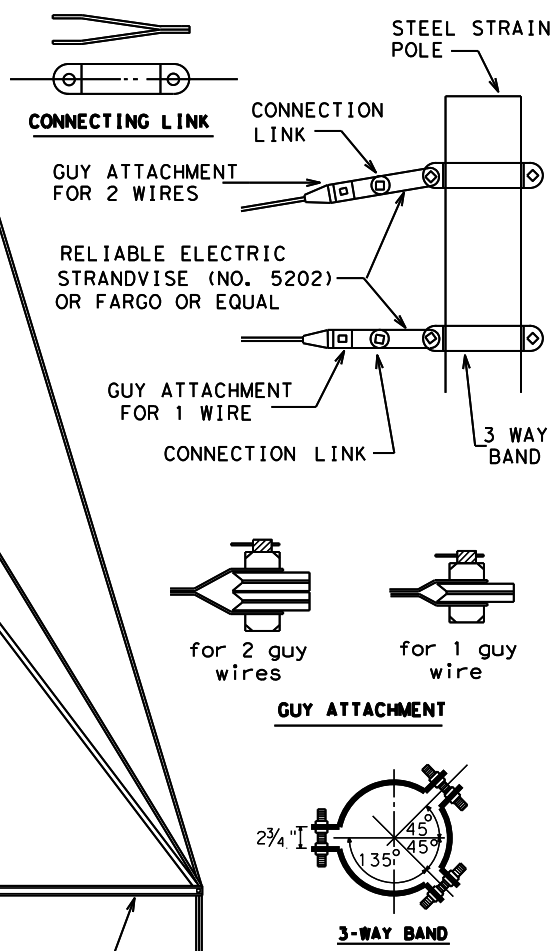

### SPAN CABLE ATTACHMENT DETAILS FOR STEEL STRAIN POLES

\* ANCHORS SHOULD BE LOCATED  
SO THAT THE DISTANCE  
BETWEEN THE ANCHOR AND THE  
POLE BUTT IS EQUAL TO THE  
DISTANCE FROM THE GROUND  
TO THE POINT OF GUY  
ATTACHMENT. IN NO CASE  
SHOULD THE DISTANCE FROM  
THE ANCHOR TO THE POLE  
BUTT BE LESS THAN 1/3 OF  
THE DISTANCE FROM THE  
GROUND TO THE POINT OF  
GUY ATTACHMENT.

### CONSTRUCTION DETAILS FOR SPAN WIRE MOUNTED TRAFFIC SIGNALS

SHEET 1 OF 3  
DALLAS DISTRICT STANDARD

FED. RD. DIST. NO.	FEDERAL AID PROJECT NO.	SHEET NO.
6	(SEE TITLE SHEET)	32
STATE	COUNTY	
TEXAS	DALLAS, ETC.	
CONTR.	SECT.	JOB
0918	00	392
		VA



**BOTTOM TETHERED, SPAN WIRE  
SIGNAL HEAD HARDWARE  
ASSEMBLY (BACKPLATE NOT SHOWN)**

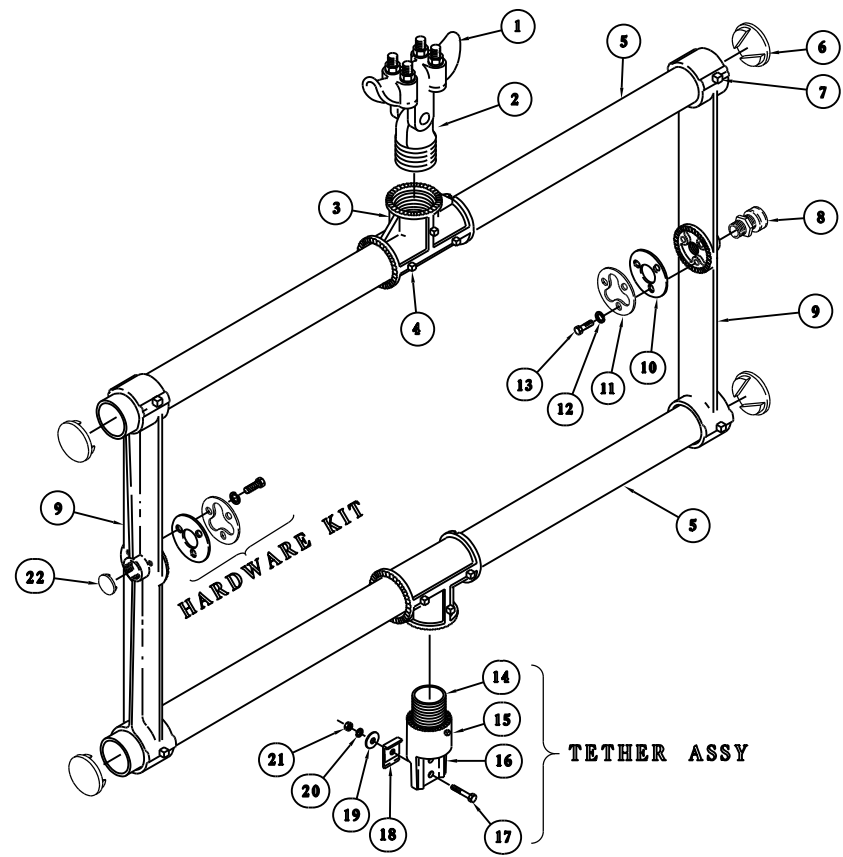

ITEM	DESCRIPTION	QTY
1	SPAN WIRE CLAMP, IRON, W/ U-BOLTS	1
2	SPAN WIRE ADAPTER, ALUM W/ STAINLESS BUSHING	1
3	TEE HORIZONTAL SLIP, DIE CAST ALUM	2
4	SCREW, SET SQ HD, 1/4"-20 X 1/2", STAINLESS	6
5	TUBE, 1/2" X LENGTH, ALUM	2
6	TUBE CAP, 1/2", PLASTIC	4
7	SCREW, SET SQ HD, 5/16"-18 X 5/8", STAINLESS	8
8	CGB, 3/4" .55-.65, ZINC 1	1
9	CAST ARM, FOR HORIZONTAL MOUNTED SIGNAL, ALUM	2
10	GASKET, TRI-BOLT, 1/16" X 70 DURO NEOPRENE	2
11	WASHER, SLOTTED, ZINC 2	2
12	WASHER, LOCK SPLIT, 1/4", STAINLESS	6
13	BOLT, HEX HD, 1/4"-20 X 1/2", GRADE 5, STAINLESS	6
14	NIPPLE, ALLTHREAD, 1/2" NPS X 2.13", ALUM	1
15	SCREW, SET SQ HD, 1/4"-20 X 5/8", STAINLESS	1
16	BODY, 1/2", HANGER, ALUM	1
17	BOLT, HEX HD, 5/16"-18 X 1 1/2", STAINLESS	1
18	PLATE, TETHER, 1-HOLE, ALUM	1
19	WASHER, FENDER, 5/16", STAINLESS	1
20	WASHER, SPLIT LOCK, 5/16", STAINLESS	1
21	NUT, HEX HD, 5/16"-18, STAINLESS	1
22	CAP, EN-3/4, BLUE (FOR CGB)	1

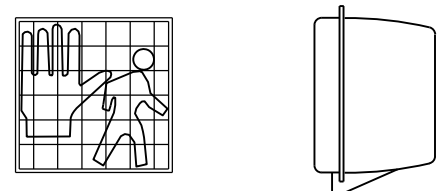

"EGGCRATE" VISOR PEDESTRIAN SIGNAL  
WITH ONE-PIECE REFLECTOR

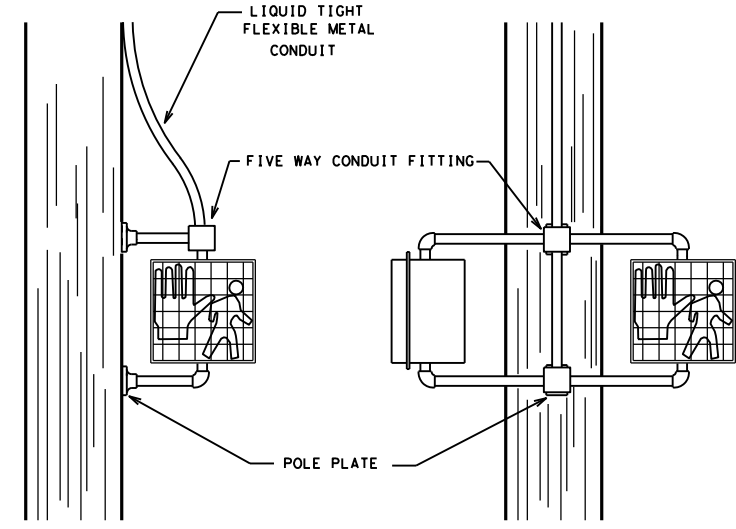

152A  
ONE-WAY  
ADJUSTABLE FACE SIGNAL FOR  
WOOD POLE MOUNTING

143C  
TWO-WAY  
ADJUSTABLE FACE SIGNAL FOR  
WOOD POLE MOUNTING

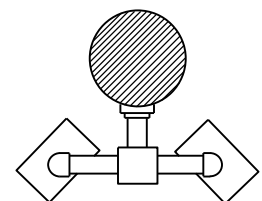

143C  
PLAN VIEW

SIGN R10-4bR  
SIGN R10-4bL  
9"X12"



PEDESTRIAN PUSHBUTTON  
SIGN DETAILS

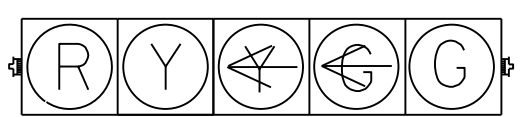

**H5LT**  
TYPICAL SPAN WIRE  
HORIZONTAL MOUNT  
INSTALLATION

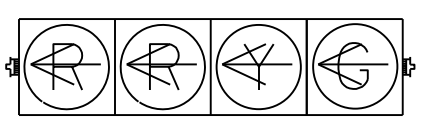

**H4LT**  
TYPICAL SPAN WIRE  
HORIZONTAL MOUNT  
INSTALLATION

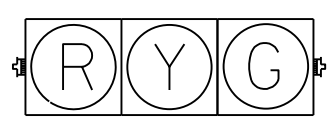

**H3**  
TYPICAL SPAN WIRE  
HORIZONTAL MOUNT  
INSTALLATION

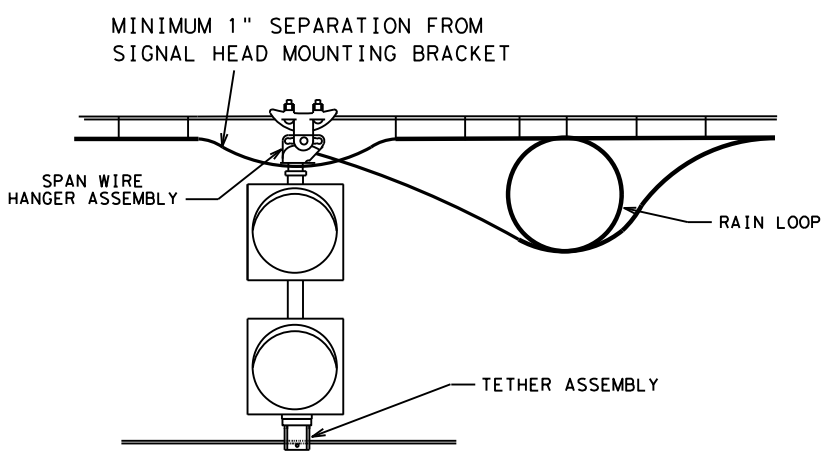

**TYPICAL  
ONE-WAY FLASHING BEACON  
INSTALLATION**

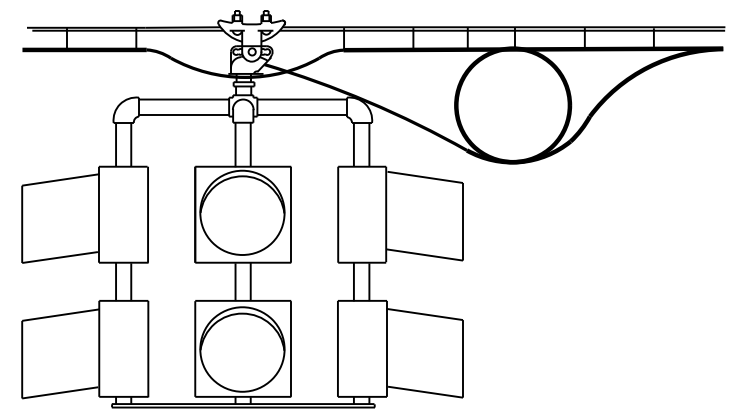

**TYPICAL  
FOUR-WAY FLASHING BEACON  
INSTALLATION**

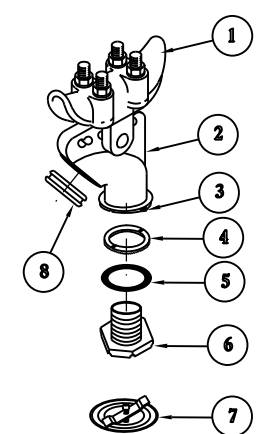

SPAN WIRE FLASHING BEACON  
SIGNAL HEAD HANGER ASSEMBLY

**SPAN WIRE FLASHING BEACON  
SIGNAL HEAD HANGER ASSEMBLY**

ITEM	DESCRIPTION	QTY
1	SPAN WIRE CLAMP, IRON, W/ U-BOLTS	1
2	WIRE OUTLET BODY, 3/4", ALUM	1
3	SET SCREW, SQUARE HD, CUP POINT, 1/4"-20X5/8", TYPE 304 STAINLESS	1
4	LOCKRING, SERRATED, 380 DIE CAST ALUM	1
5	GASKET, 70 DURO NEOPRENE	1
6	NIPPLE, HEX, 1-1/2" NPS, ALUM	1
7	KIT, SIGNAL CLOSURE	1
8	GROMMET, 1-1/2", W/ DIAPHRAGM	1

CONSTRUCTION DETAILS FOR SPAN  
WIRE MOUNTED TRAFFIC SIGNALS

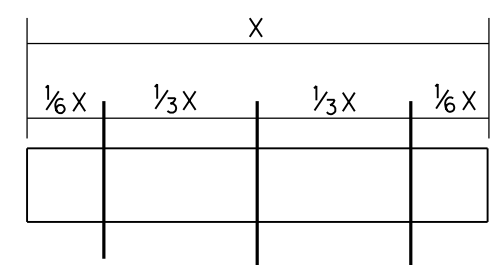
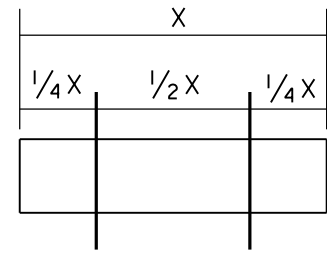
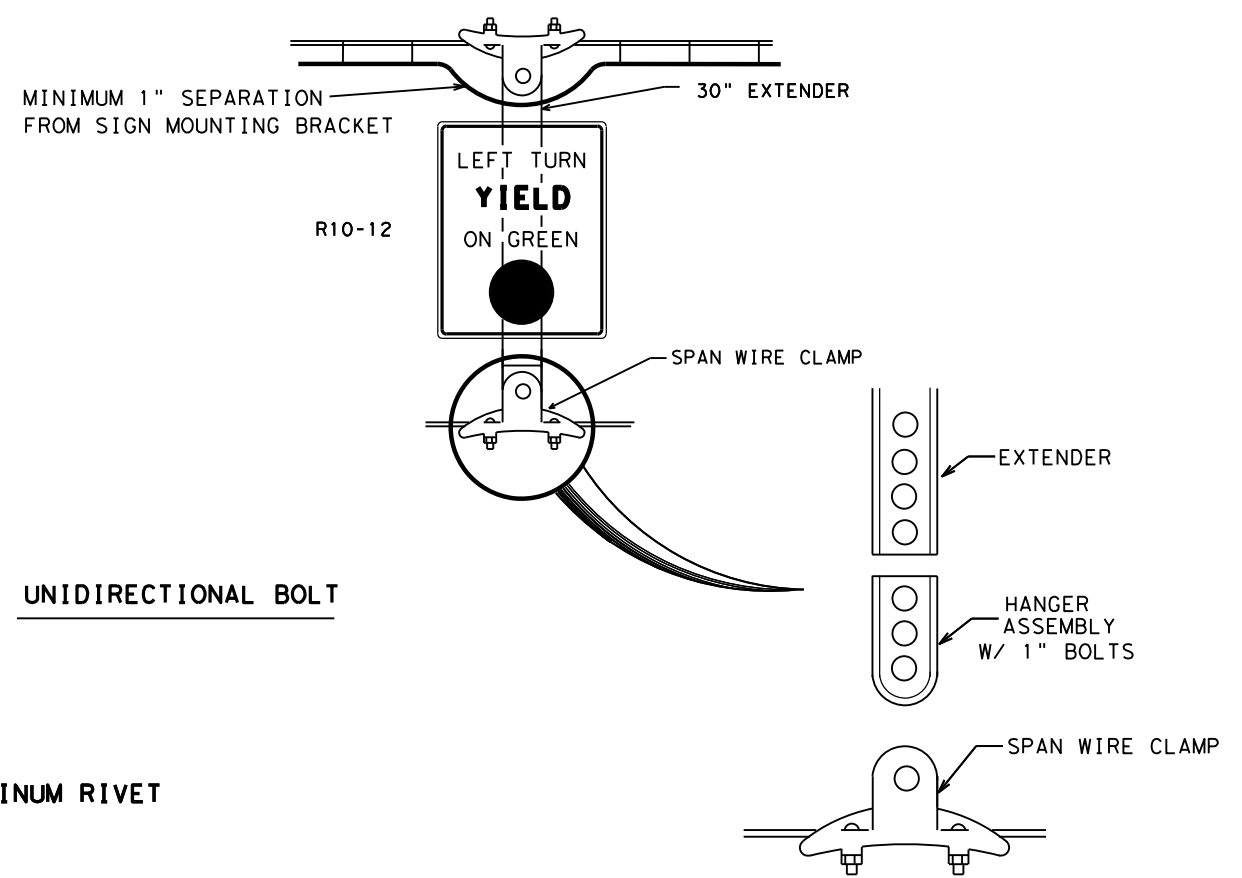
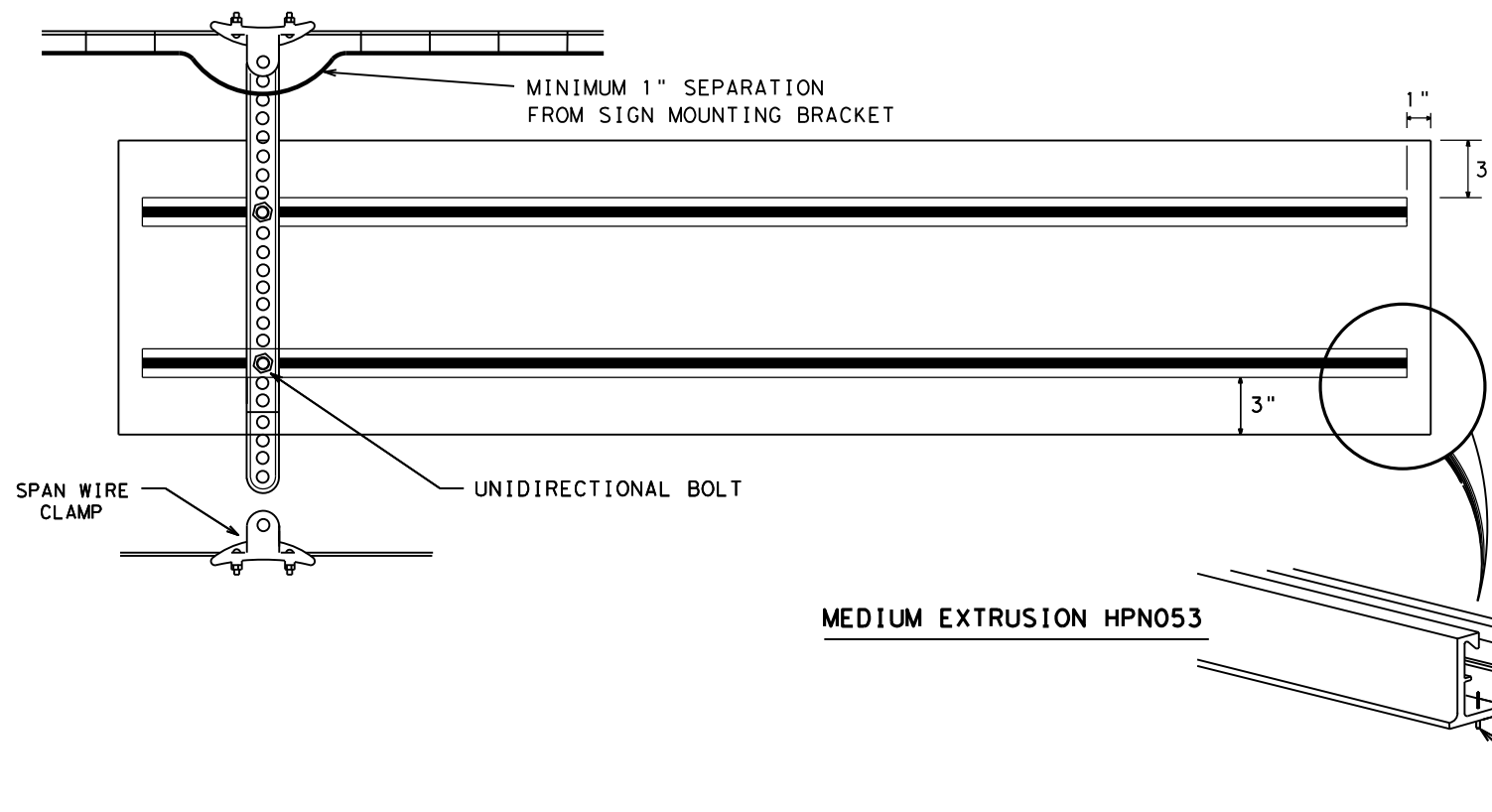

**HANGER ASSEMBLY DETAILS**

- NOTES: 1. BASED ON SIGN WIDTH, THE NUMBER OF VERTICAL SUPPORTS REQUIRED ARE AS FOLLOWS:  
 3'-0" OR LESS - 1 SUPPORT REQUIRED  
 >3'-0" UP TO 8'-0" - 2 SUPPORTS REQUIRED  
 >8'-0" - 3 SUPPORTS REQUIRED  
 SEE DIAGRAMS FOR SIGN SUPPORT SPACING
2. FOR STREET NAME SIGNS, EXTRUDED ALUMINUM SHALL BE MOUNTED FOR HORIZONTAL SUPPORT AS SHOWN.

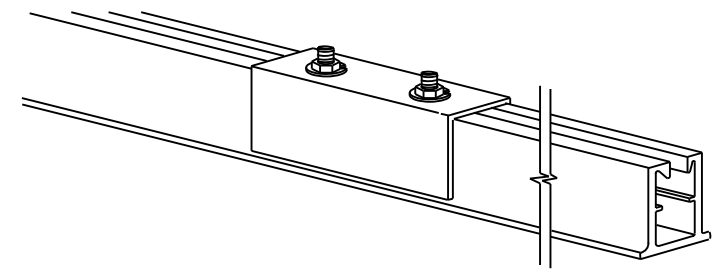

**5" ALUMINUM COUPLING**  
6061-T6

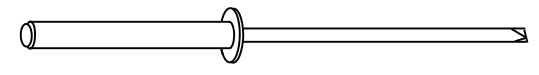

**ALUMINUM RIVET**

NOTE: ALUMINUM RIVETS SHALL BE USED TO ATTACH THE SIGN TO THE EXTRUDED ALUMINUM. SPACINGS OF RIVETS SHALL BE 6" O.C.

SHEET 3 OF 3  
DALLAS DISTRICT STANDARD

FED. DIV. NO.	FEDERAL AID PROJECT NO.	SHEET NO.
6	(SEE TITLE SHEET)	34
STATE	DIST. NO.	COUNTY
TEXAS	DAL	DALLAS, ETC.
CONT.	SECT.	JOB HIGHWAY NO.
0918	00	392 VA

CONSTRUCTION DETAILS FOR SPAN WIRE MOUNTED TRAFFIC SIGNALS

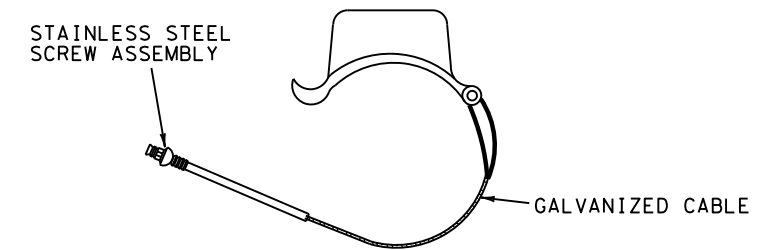
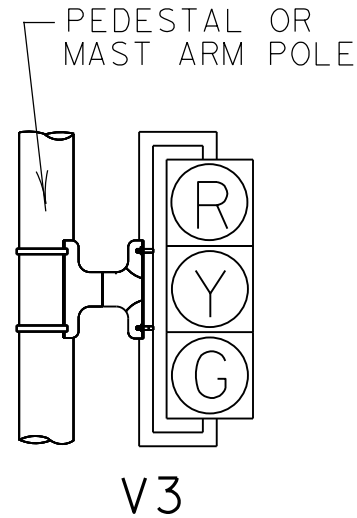
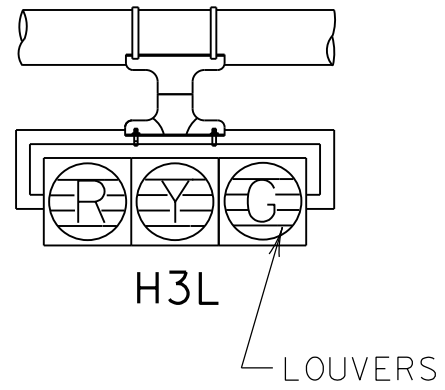
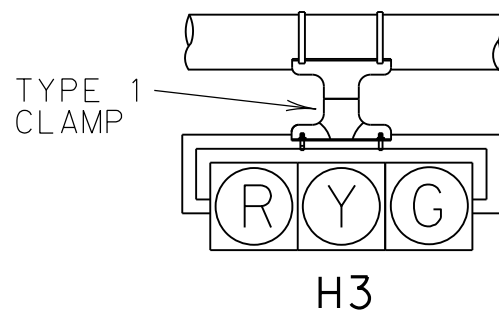

TYPE 1 AND 2 CLAMPS

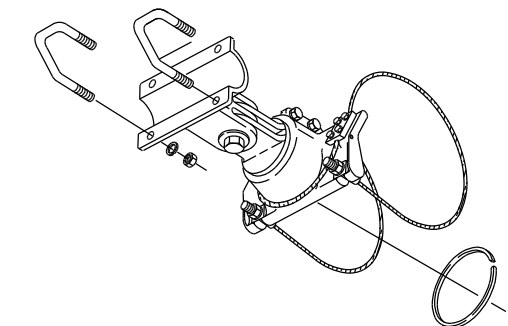
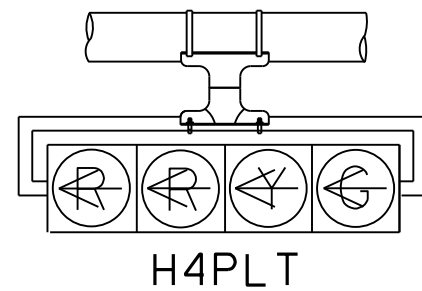
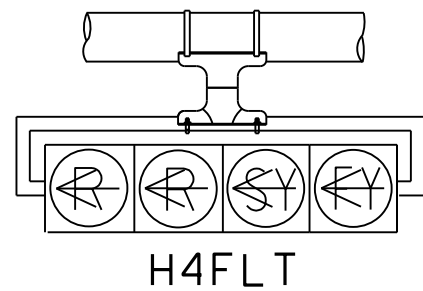
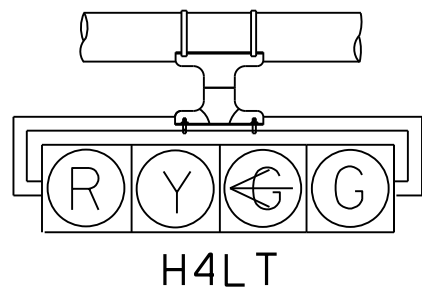

TYPE 2 CLAMP KIT

SHALL BE INSTALLED WHEN ROTATION ABOUT THE HORIZONTAL AND VERTICAL AXES ARE NEEDED.

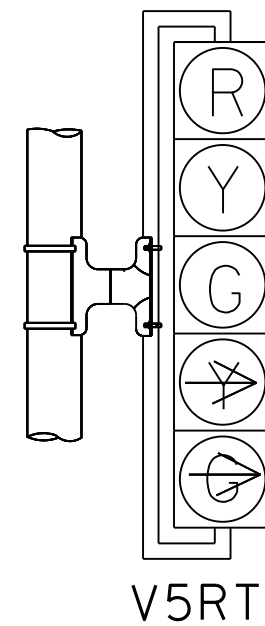
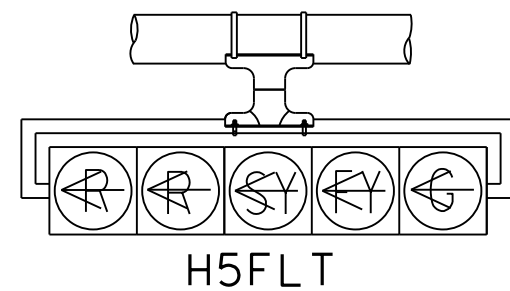
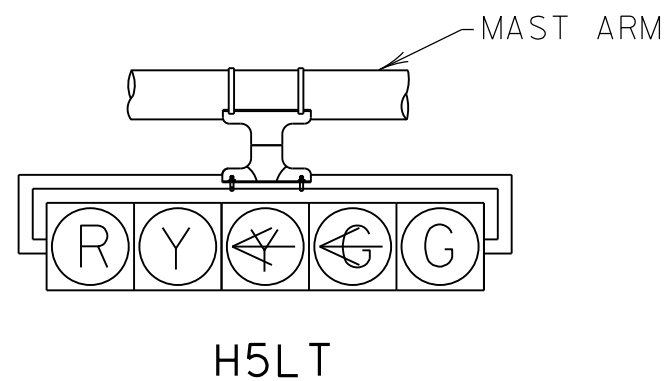

NOTES:

1. VEHICLE SIGNAL HEADS SHALL BE MOUNTED WITH TYPE 1 CLAMP AND APPROPRIATE TUBING.
2. ALL POLE MOUNTED VEHICLE HEADS SHALL BE INSTALLED ON THE AWAY-FROM-TRAFFIC SIDE OF THE PEDESTAL OR MAST ARM POLE.
3. THE SIGNAL HEADS SHOWN ARE NOT MEANT TO REFLECT ALL POSSIBLE SIGNAL HEADS, BUT ARE REPRESENTATIVE OF SIGNAL HEADS COMMONLY IN USE. SEE THE TRAFFIC SIGNAL LAYOUT FOR REQUIRED SIGNAL HEADS, AND THE NUMBER AND ORIENTATION OF LOUVERS.

TRAFFIC SIGNAL HEAD DETAILS (DAL)

© TXDOT 2018  
DALLAS DISTRICT STANDARD

FED. RD. DIV. NO.	FEDERAL AID PROJECT NO.	SHEET NO.
6	(SEE TITLE SHEET)	35
STATE	STATE DIST.	COUNTY
TEXAS	18	DALLAS
CONT.	SECT.	JOB HIGHWAY NO.
0918	00	392 VA

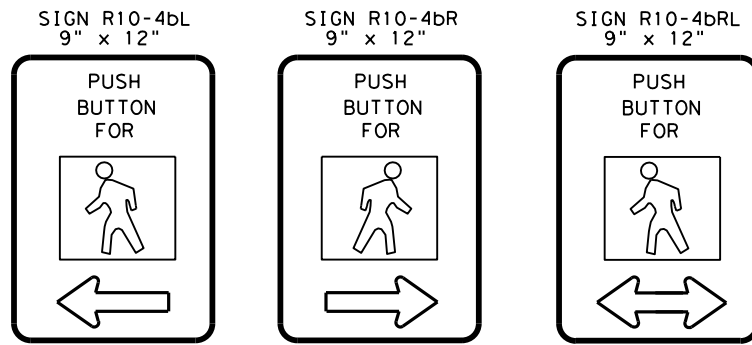

PEDESTRIAN PUSHBUTTON SIGN DETAILS

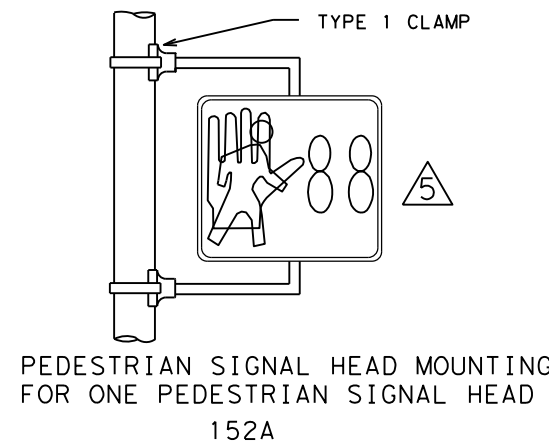

PEDESTRIAN SIGNAL HEAD MOUNTING FOR ONE PEDESTRIAN SIGNAL HEAD 152A

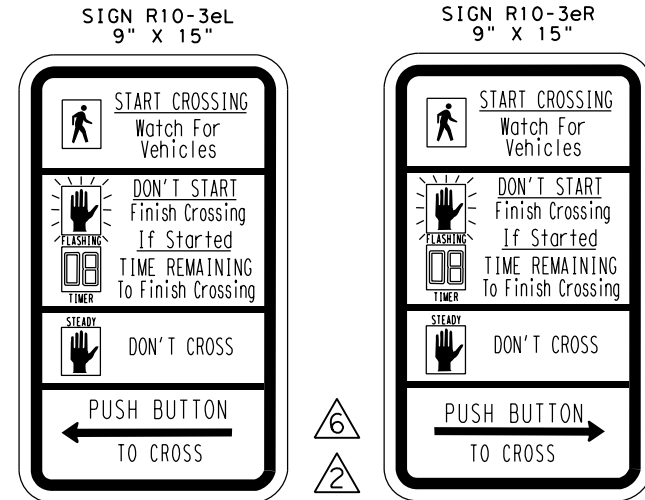

COUNTDOWN PEDESTRIAN PUSHBUTTON SIGN DETAILS

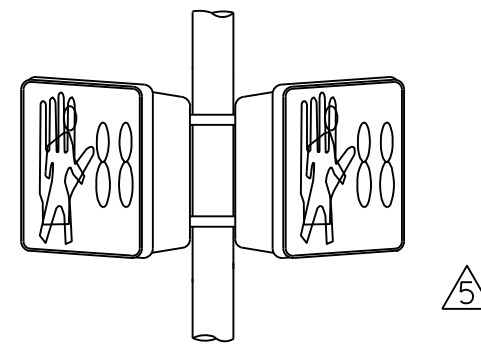

PEDESTRIAN SIGNAL HEAD MOUNTING FOR TWO PEDESTRIAN SIGNAL HEADS 143C

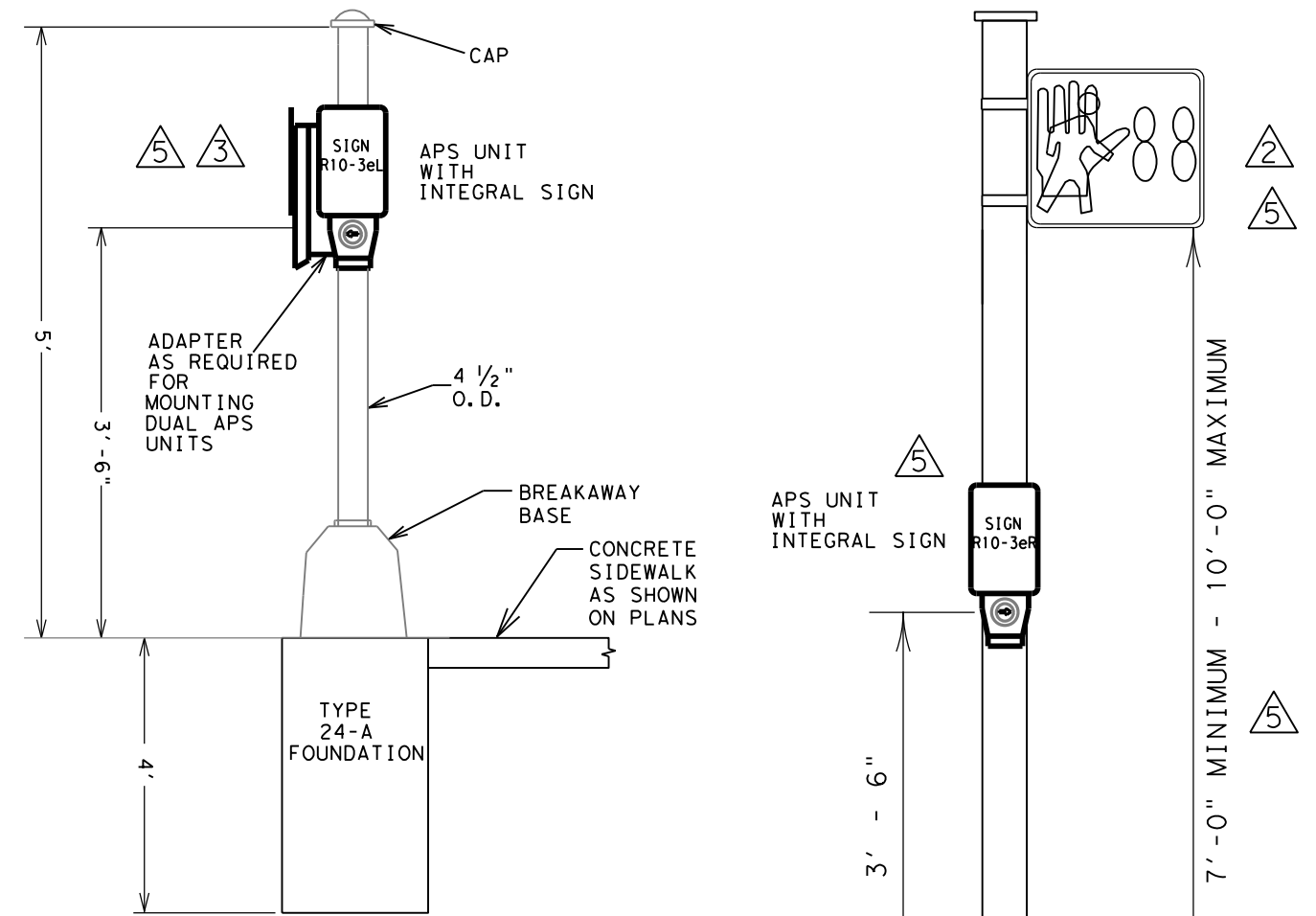

PEDESTRIAN PUSH BUTTON POLE

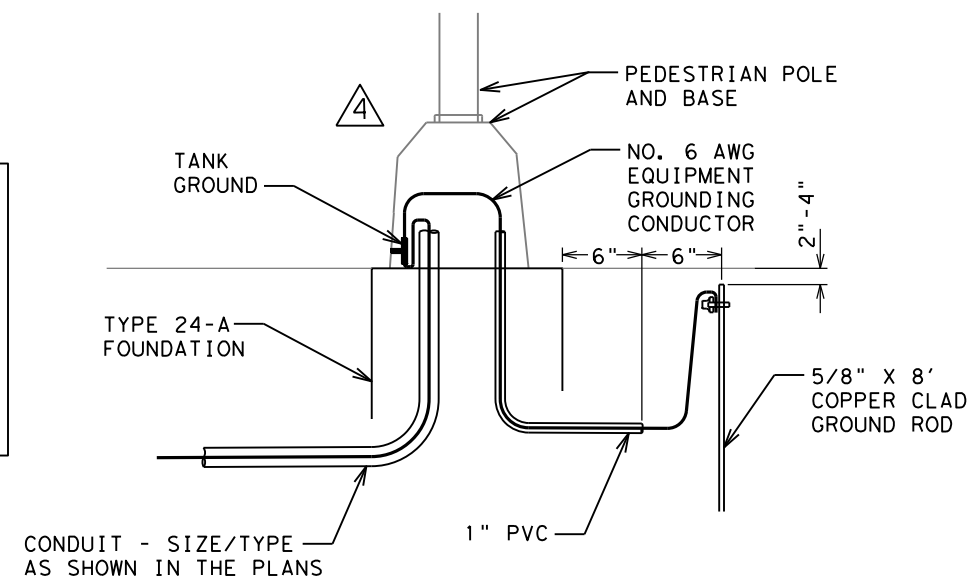

PEDESTRIAN PUSH BUTTON POLE GROUNDING DETAILS

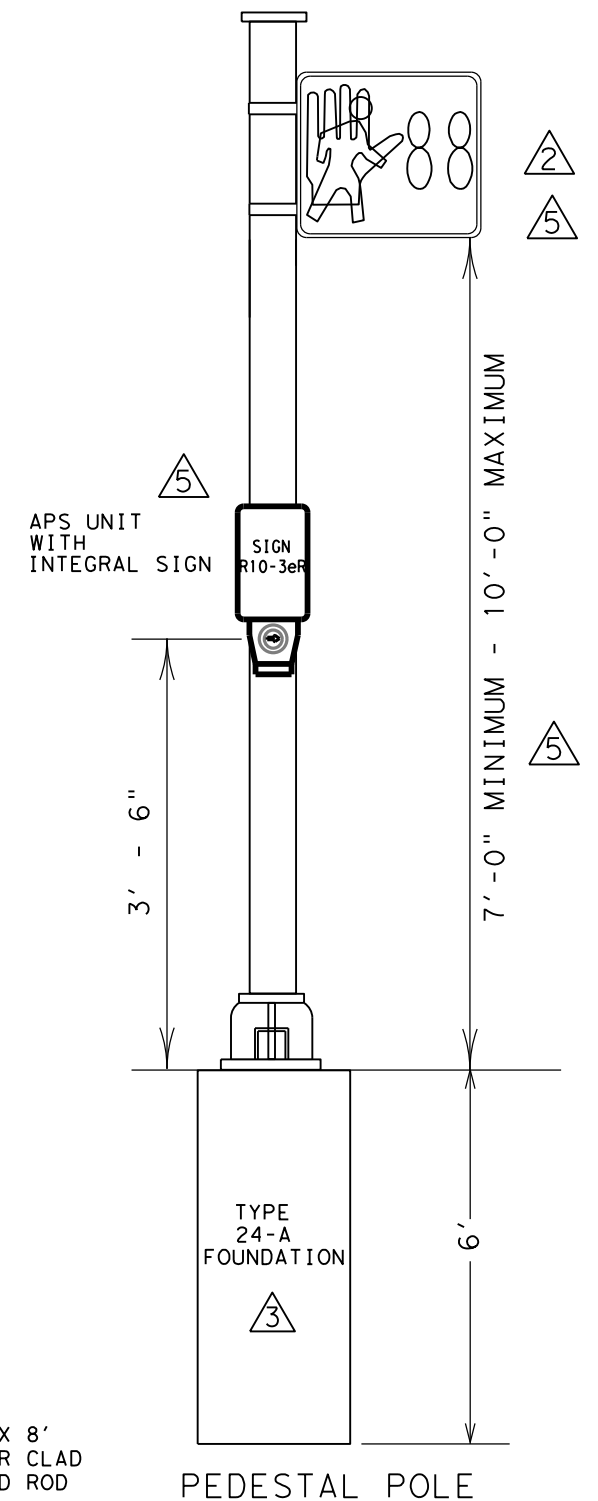

PEDESTAL POLE

NOTE: EITHER TYPE 1 CLAMPS OR CLAM SHELL MOUNTING HARDWARE MAY BE USED AS APPROVED BY THE ENGINEER. FOR CLAM SHELLS, USE ICC P/N 4805 OR McCAIN QUICKMOUNT OR APPROVED EQUAL.

- 1 ALTERNATIVE MOUNTING METHOD revised 12-92
- 2 ALTERNATIVE PEDESTRIAN SIGNAL HEAD AND SIGNING revised 10-08
- 3 PEDESTRIAN PUSH BUTTON POLE revised 01-11
- 4 PEDESTRIAN PUSH BUTTON POLE GROUNDING DETAILS revised 09-15
- 5 APS UNIT ADDED "SYMBOLS ONLY" PEDESTRIAN SIGNAL HEAD REMOVED MOUNTING HARDWARE NOTES REVISED MOUNTING HEIGHT REVISED revised 06-17
- 6 APS SIGN REVISED revised 11-20

- NOTES:
- 1. ALL PEDESTRIAN SIGNAL HEADS SHALL BE INSTALLED ON THE AWAY-FROM-TRAFFIC SIDE OF THE PEDESTAL OR MAST ARM POLE.
  - 2. ALL WIRING FOR PEDESTRIAN SIGNALS SHALL BE TOTALLY ENCLOSED WITHIN THE SIGNAL MOUNTING HARDWARE.
  - 3. ALL PEDESTRIAN SIGNAL HEADS AND PUSH BUTTON SIGNS SHALL DISPLAY THE SYMBOLIZED MESSAGES SHOWN ABOVE.

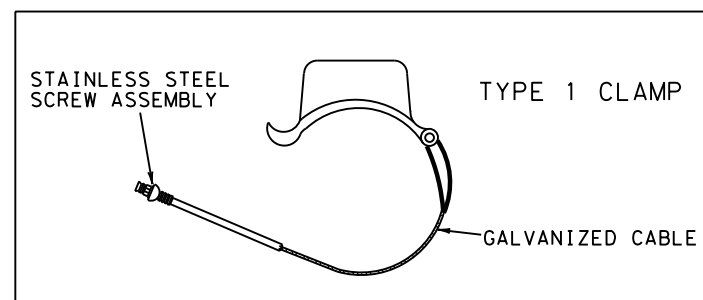

NOTE: THE POLES ON THIS DRAWING ARE SHOWN AS AN EXAMPLE ONLY. POLES OF SIMILAR DESIGN FOR ANY CROSS SECTION WHICH MEET THE SPECIFICATIONS AND REQUIREMENTS SHOWN ON THESE DRAWINGS AND ARE APPROVED BY THE ENGINEER WILL BE DEEMED ACCEPTABLE.

**PEDESTRIAN SIGNAL HEAD DETAILS (DAL)**

© TXDOT 2020  
DALLAS DISTRICT STANDARD

FED. RD. DIV. NO.	PROJECT NO.	SHEET NO.
6	(SEE TITLE SHEET)	36
STATE	STATE DIST.	COUNTY
TEXAS	18	DALLAS, ETC.
CONV.	SECT.	JOB HIGHWAY NO.
0918	00	392 VA

DISCLAIMER: The use of this standard is governed by the "Texas Engineering Practice Act". No warranty of any kind is made by TxDOT for any purpose whatsoever. TxDOT assumes no responsibility for the conversion of this standard to other formats or for incorrect results or damages resulting from its use.

DATE: FILE:

## REQUIREMENTS FOR INDEPENDENT MOUNTED ROUTE SIGNS

SHEETING REQUIREMENTS		
USAGE	COLOR	SIGN FACE MATERIAL
BACKGROUND	WHITE	TYPE A SHEETING
BACKGROUND	ALL OTHERS	TYPE B OR C SHEETING
LEGEND & BORDERS	WHITE	TYPE A SHEETING
LEGEND & BORDERS	BLACK	ACRYLIC NON-REFLECTIVE FILM
LEGEND & BORDERS	ALL OTHERS	TYPE B or C SHEETING

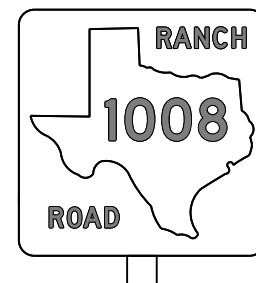
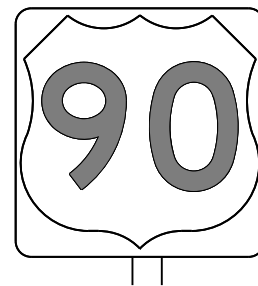

TYPICAL EXAMPLES

## REQUIREMENTS FOR BLUE, BROWN & GREEN D AND I SERIES GUIDE SIGNS

SHEETING REQUIREMENTS		
USAGE	COLOR	SIGN FACE MATERIAL
BACKGROUND	ALL	TYPE B OR C SHEETING
LEGEND & BORDERS	WHITE	TYPE D SHEETING
LEGEND, SYMBOLS & BORDERS	ALL OTHERS	TYPE B OR C SHEETING

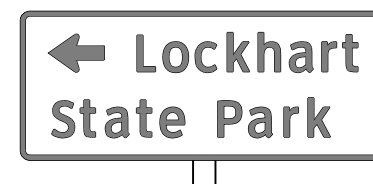
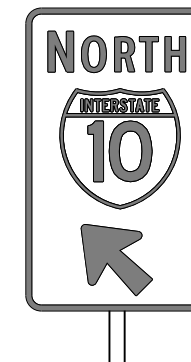
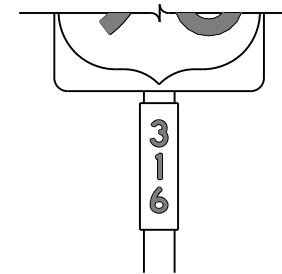

TYPICAL EXAMPLES

### GENERAL NOTES

- Signs to be furnished shall be as detailed elsewhere in the plans and/or as shown on sign tabulation sheet. Standard sign designs and arrow dimensions can be found in the "Standard Highway Sign Designs for Texas" (SHSD).
- White legend shall use the Clearview Alphabet. The following Clearview fonts shall be used to replace the existing white Federal Highway Administration (FHWA) Standard Highway Alphabets, when not specified in the SHSD, or in the plans.

B	CV-1W
C	CV-2W
D	CV-3W
E	CV-4W
Emod	CV-5WR
F	CV-6W

- Route sign legend (ie. IH, US, SH and FM shields) shall use the Federal Highway Administration (FHWA) Standard Highway Alphabets B, C, D, E, Emod or F).
- Lateral spacing between letters and numerals shall conform with the SHSD, and any approved changes thereto. Lateral spacing of legend shall provide a balanced appearance when spacing is not shown.
- Independent mounted route sign with white or colored legend and borders shall be applied by screening process with transparent color ink, transparent colored overlay film to white background sheeting or cut-out white sheeting to colored background sheeting, or combination thereof. White legend, symbols and borders on all other signs shall be cut-out white sheeting applied to colored background sheeting.
- Information regarding borders and radii for signs is found in the "Standard Highway Sign Designs for Texas". Dimensions shown and described for borders and corner radii on parent sign are nominal. Borders may vary in width as much as 1/2 inch. Corner radii above 3 inches may vary in width as much as 1 inch. Borders and corner radii within a parent sign must be of matching widths. The sign area outside the corner radius should be trimmed or rounded.
- Sign substrate shall be any material that meets the Departmental Material Specification requirements of DMS-7110 or approved alternative.
- Mounting details of roadside signs are shown in the "SMD series" Standard Plan Sheets.

DEPARTMENTAL MATERIAL SPECIFICATIONS	
ALUMINUM SIGN BLANKS	DMS-7110
SIGN FACE MATERIALS	DMS-8300

ALUMINUM SIGN BLANKS THICKNESS	
Square Feet	Minimum Thickness
Less than 7.5	0.080
7.5 to 15	0.100
Greater than 15	0.125

The Standard Highway Sign Designs for Texas (SHSD) can be found at the following website:  
<http://www.txdot.gov/>

<b>Texas Department of Transportation</b>	<i>Traffic Operations Division Standard</i>
<h2 style="margin: 0;">TYPICAL SIGN REQUIREMENTS</h2> <h3 style="margin: 0;">TSR(3) - 13</h3>	
FILE: tsr3-13.dgn    DN: TxDOT    CK: TxDOT    DW: TxDOT    CR: TxDOT © TxDOT October 2003    CONT SECT JOB HIGHWAY REVISIONS    0918 00    392    VA 12-03 7-13    DIST COUNTY SHEET NO. 9-08    DAL DALLAS, ETC.    37	

DISCLAIMER: The use of this standard is governed by the "Texas Engineering Practice Act". No warranty of any kind is made by TxDOT for any purpose whatsoever. TxDOT assumes no responsibility for the conversion of this standard to other formats or for incorrect results or damages resulting from its use.

DATE: FILE:

### REQUIREMENTS FOR RED BACKGROUND REGULATORY SIGNS

(STOP, YIELD, DO NOT ENTER AND WRONG WAY SIGNS)

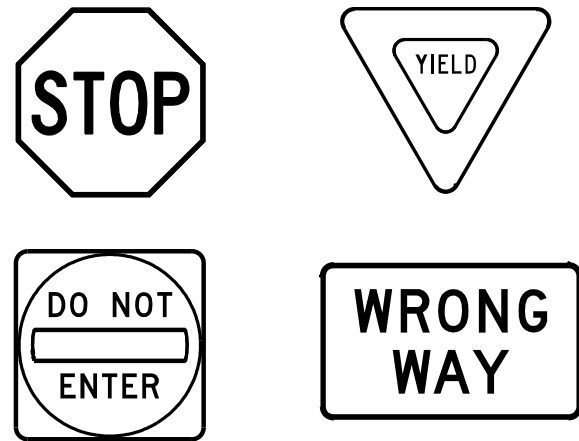

#### REQUIREMENTS FOR FOUR SPECIFIC SIGNS ONLY

SHEETING REQUIREMENTS		
USAGE	COLOR	SIGN FACE MATERIAL
BACKGROUND	RED	TYPE B OR C SHEETING
BACKGROUND	WHITE	TYPE B OR C SHEETING
LEGEND & BORDERS	WHITE	TYPE B OR C SHEETING
LEGEND	RED	TYPE B OR C SHEETING

### REQUIREMENTS FOR WHITE BACKGROUND REGULATORY SIGNS

(EXCLUDING STOP, YIELD, DO NOT ENTER AND WRONG WAY SIGNS)



#### TYPICAL EXAMPLES

SHEETING REQUIREMENTS		
USAGE	COLOR	SIGN FACE MATERIAL
BACKGROUND	WHITE	TYPE A SHEETING
BACKGROUND	ALL OTHERS	TYPE B OR C SHEETING
LEGEND, BORDERS AND SYMBOLS	BLACK	ACRYLIC NON-REFLECTIVE FILM
LEGEND, BORDERS AND SYMBOLS	ALL OTHER	TYPE B OR C SHEETING

### REQUIREMENTS FOR WARNING SIGNS

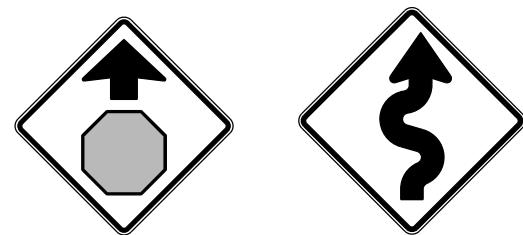

#### TYPICAL EXAMPLES

SHEETING REQUIREMENTS		
USAGE	COLOR	SIGN FACE MATERIAL
BACKGROUND	FLOURESCENT YELLOW	TYPE B <sub>FL</sub> OR C <sub>FL</sub> SHEETING
LEGEND & BORDERS	BLACK	ACRYLIC NON-REFLECTIVE FILM
LEGEND & SYMBOLS	ALL OTHER	TYPE B OR C SHEETING

### REQUIREMENTS FOR SCHOOL SIGNS



#### TYPICAL EXAMPLES

SHEETING REQUIREMENTS		
USAGE	COLOR	SIGN FACE MATERIAL
BACKGROUND	WHITE	TYPE A SHEETING
BACKGROUND	FLOURESCENT YELLOW GREEN	TYPE B <sub>FL</sub> OR C <sub>FL</sub> SHEETING
LEGEND, BORDERS AND SYMBOLS	BLACK	ACRYLIC NON-REFLECTIVE FILM
SYMBOLS	RED	TYPE B OR C SHEETING

### GENERAL NOTES

- Signs to be furnished shall be as detailed elsewhere in the plans and/or as shown on sign tabulation sheet. Standard sign designs and arrow dimensions can be found in the "Standard Highway Sign Designs for Texas" (SHSD).
- Sign legend shall use the Federal Highway Administration (FHWA) Standard Highway Alphabets (B, C, D, E, Emod or F).
- Lateral spacing between letters and numerals shall conform with the SHSD, and any approved changes thereto. Lateral spacing of legend shall provide a balanced appearance when spacing is not shown.
- Black legend and borders shall be applied by screening process or cut-out acrylic non-reflective black film to background sheeting, or combination thereof.
- White legend and borders shall be applied by screening process with transparent colored ink, transparent colored overlay film to white background sheeting or cut-out white sheeting to colored background sheeting, or combination thereof.
- Colored legend shall be applied by screening process with transparent colored ink, transparent colored overlay film or colored sheeting to background sheeting, or combination thereof.
- Sign substrate shall be any material that meets the Departmental Material Specification requirements of DMS-7110 or approved alternative.
- Mounting details for roadside mounted signs are shown in the "SMD series" Standard Plan Sheets.

#### ALUMINUM SIGN BLANKS THICKNESS

Square Feet	Minimum Thickness
Less than 7.5	0.080
7.5 to 15	0.100
Greater than 15	0.125

#### DEPARTMENTAL MATERIAL SPECIFICATIONS

ALUMINUM SIGN BLANKS	DMS-7110
SIGN FACE MATERIALS	DMS-8300

The Standard Highway Sign Designs for Texas (SHSD) can be found at the following website.

<http://www.txdot.gov/>



## TYPICAL SIGN REQUIREMENTS

### TSR(4) - 13

FILE: tsr4-13.dgn	DN: TxDOT	CK: TxDOT	DW: TxDOT	CR: TxDOT
© TxDOT October 2003	CONT	SECT	JOB	HIGHWAY
REVISIONS	0918	00	392	VA
12-03 7-13	DIST	COUNTY	SHEET NO.	
9-08	DAL	DALLAS, ETC.	38	

DISCLAIMER: The use of this standard is governed by the "Texas Engineering Practice Act". No warranty of any kind is made by TxDOT for any purpose whatsoever. TxDOT assumes no responsibility for the conversion of this standard to other formats or for incorrect results or damages resulting from its use.

### ARROW DETAILS

for Large Ground-Mounted and Overhead Guide Signs

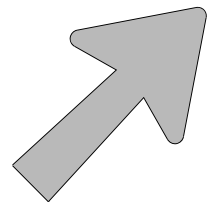

Type A

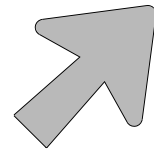

Type B

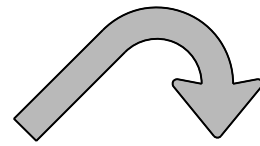

E-3

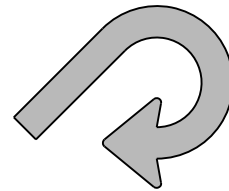

E-4

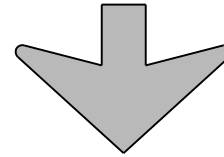

Down Arrow

TYPE	LETTER SIZE	USE
A-1	10.67" U/L and 10" Caps	Single Lane Exits
A-2	13.33" U/L and 12" Caps	
A-3	16" & 20" U/L	
B-1	10.67" U/L and 10" Caps	Multiple Lane Exits
B-2	13.33" U/L and 12" Caps	
B-3	16" & 20" U/L	

CODE	USED ON SIGN NO.
E-3	E5-1aT
E-4	E5-1bT

**NOTE**

Arrow dimensions are shown in the "Standard Highway Sign Designs for Texas" manual.

The Standard Highway Sign Designs for Texas (SHSD) can be found at the following website:  
<http://www.txdot.gov/>

### SIGN BLANK PUNCHING DETAILS FOR ATTACHMENTS WHEN SPECIFIED TO BE TYPE A ALUMINUM SIGNS (FOR MOUNTING TO GUIDE SIGN FACE)

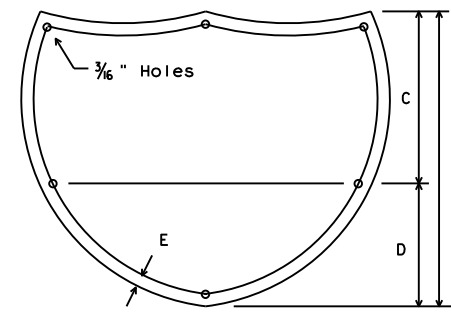

INTERSTATE ROUTE MARKERS

A	C	D	E
36	21	15	1 1/2
48	28	20	1 3/4

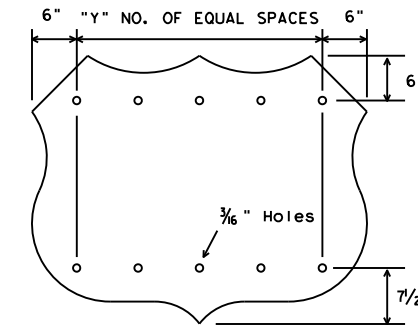

U.S. ROUTE MARKERS

Sign Size	"Y"
24x24	2
30x24	3
36x36	3
45x36	4
48x48	4
60x48	5

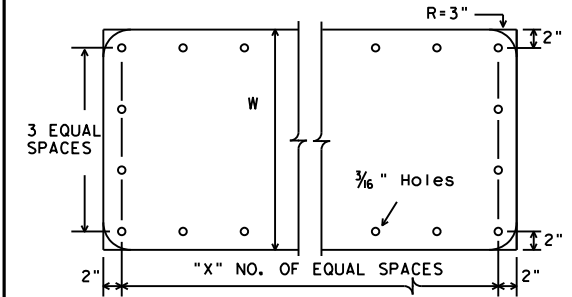

STATE ROUTE MARKERS

No. of Digits	W	X
4	24	4
4	36	5
4	48	6
3	24	3
3	36	4
3	48	5

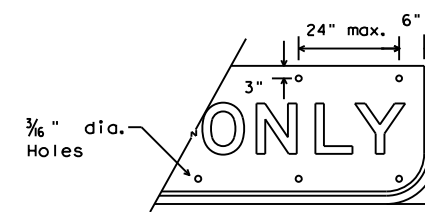

EXIT ONLY PANEL

### MOUNTING DETAILS OF ATTACHMENTS TO GUIDE SIGN FACE ("EXIT ONLY" AND "LEFT EXIT" PANELS, ROUTE MARKERS AND OTHER ATTACHMENTS)

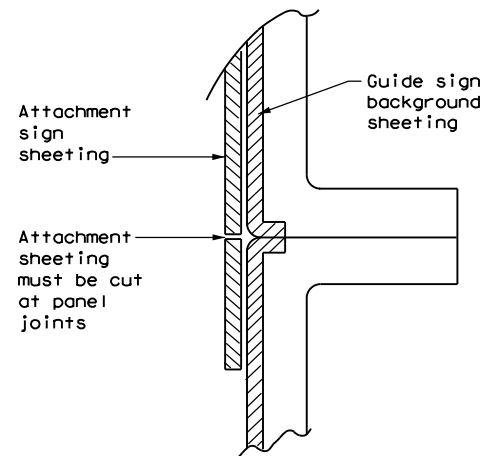

DIRECT APPLIED ATTACHMENT

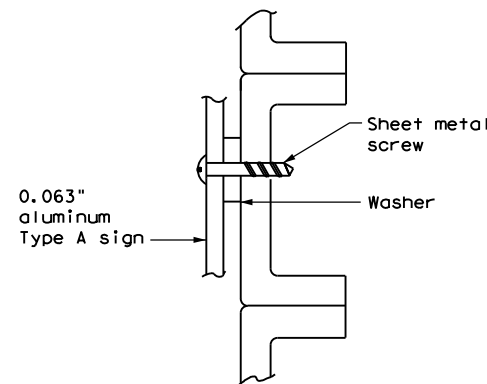

SCREW ATTACHMENT

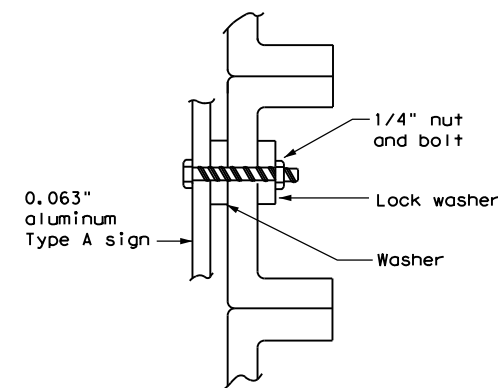

NUT/BOLT ATTACHMENT

**NOTE:**

- Sheeting for legend, symbols, and borders must be cut at panel joints.
- Direct applied attachment signs will be subsidiary to "Aluminum Signs" or "Fiberglass Signs".

### ARROW DETAILS for Destination Signs (Type D)

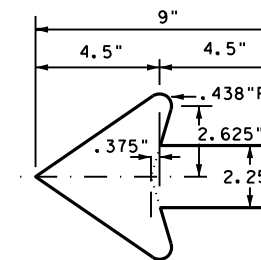

Standard arrow to be used with 6 inch letters.

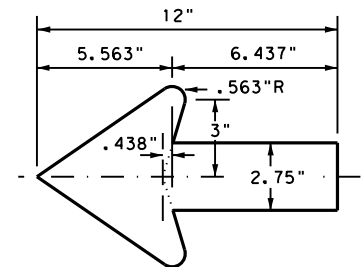

Standard arrow to be used with 8 inch letters.



## TYPICAL SIGN REQUIREMENTS

### TSR (5) - 13

FILE: tsr5-13.dgn	DN: TxDOT	CK: TxDOT	DW: TxDOT	CK: TxDOT
© TxDOT October 2003	CONT	SECT	JOB	HIGHWAY
REVISIONS	0918 00		392	VA
12-03 7-13	DIST	COUNTY		SHEET NO.
9-08	DAL	DALLAS, ETC.		39

DATE:  
FILE:

DISCLAIMER: The use of this standard is governed by the "Texas Engineering Practice Act". No warranty of any kind is made by TxDOT for any purpose whatsoever. TxDOT assumes no responsibility for the conversion of this standard to other formats or for incorrect results or damages resulting from its use.

## SIGN SUPPORT DESCRIPTIVE CODES

(Descriptive Codes correspond to project estimate and quantities sheets)

SM RD SGN ASSM TY XXXXX(X)XX(X-XXXX)

### Post Type

- FRP = Fiberglass Reinforced Plastic Pipe (see SMD(FRP))
- TWT = Thin-Walled Tubing (see SMD(TWT))
- 10BWG = 10 BWG Tubing (see SMD(SLIP-1) to (SLIP-3))
- S80 = Schedule 80 Pipe (see SMD(SLIP-1) to (SLIP-3))

### Number of Posts (1 or 2)

### Anchor Type

- UA = Universal Anchor - Concreted (see SMD(FRP) and (TWT))
- UB = Universal Anchor - Bolted down (see SMD(FRP) and (TWT))
- WS = Wedge Anchor Steel - (see SMD(TWT))
- WP = Wedge Anchor Plastic (see SMD(TWT))
- SA = Slipbase - Concreted (see SMD(SLIP-1) to (SLIP-3))
- SB = Slipbase - Bolted Down (see SMD(SLIP-1) to (SLIP-3))

### Sign Mounting Designation

- P = Prefab. "Plain" (see SMD(SLIP-1) to (SLIP-3), (TWT), (FRP))
- T = Prefab. "T" (see SMD(SLIP-1) to (SLIP-3), (TWT))
- U = Prefab. "U" (see SMD(SLIP-1) to (SLIP-3))
- IF REQUIRED
- 1EXT or 2EXT = Number of Extensions (see SMD(SLIP-1) to (SLIP-3), (TWT))
- BM = Extruded Wind Beam (see SMD(SLIP-1) to (SLIP-3))
- WC = 1.12 #/ft Wing Channel (see SMD(SLIP-1) to (SLIP-3))
- EXAL = Extruded Aluminum Sign Panels (see SMD(SLIP-3))

## REQUIRED CLEARANCE FOR BREAKAWAY SUPPORT

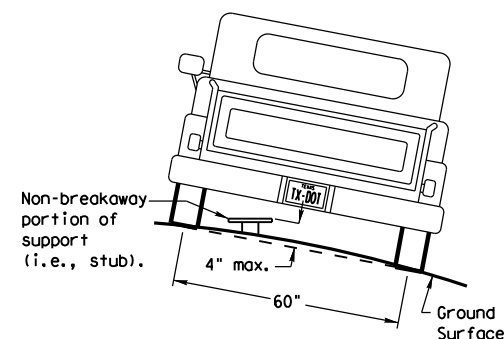

To avoid vehicle undercarriage snagging, any substantial remains of a breakaway support, when it is broken away, should not project more than 4 inches above a 60-inch chord (i.e., typical space between wheel paths).

## SIGN LOCATION

### PAVED SHOULDERS

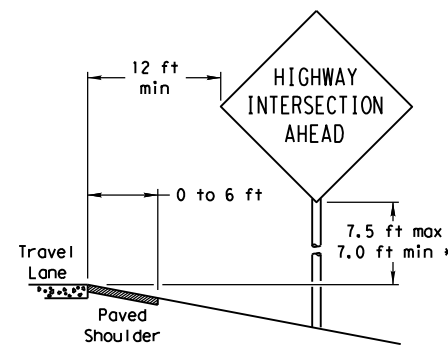

#### LESS THAN 6 FT. WIDE

When the shoulder is 6 ft. or less in width, the sign must be placed at least 12 ft. from the edge of the travel lane.

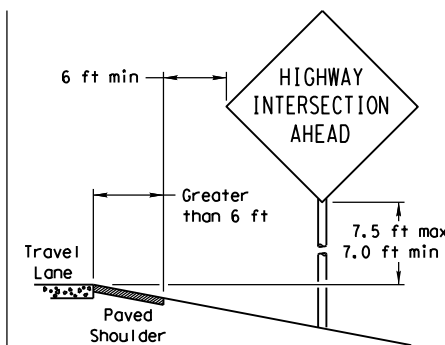

#### GREATER THAN 6 FT. WIDE

When the shoulder is greater than 6 ft. in width, the sign must be placed at least 6 ft. from the edge of the shoulder.

### T-INTERSECTION

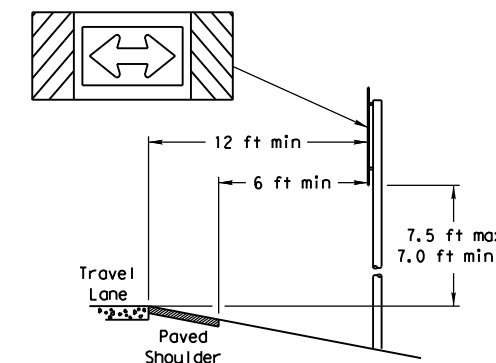

When this sign is needed at the end of a two-lane, two way roadway, the right edge of the sign should be in line with the centerline of the roadway. Place as close to ROW as practical.

No more than 2 sign posts should be located within a 7 ft. circle.

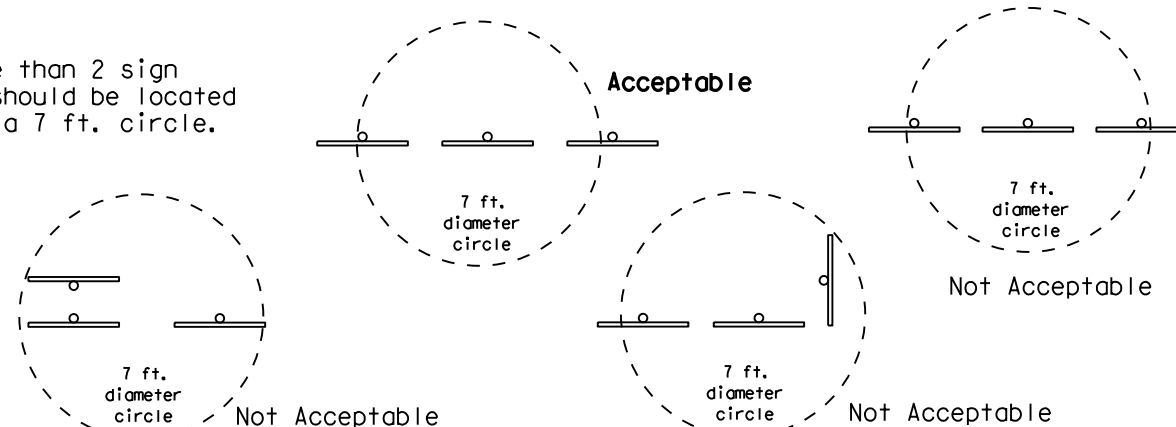

### BEHIND BARRIER

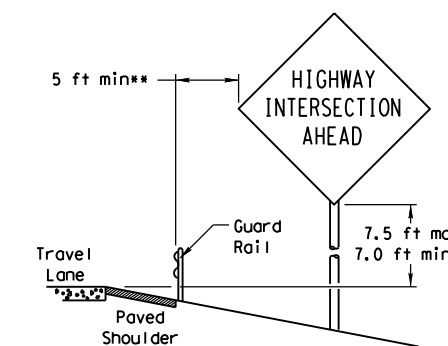

#### BEHIND GUARDRAIL

\*\*Sign clearance based on distance required for proper guard rail or concrete barrier performance.

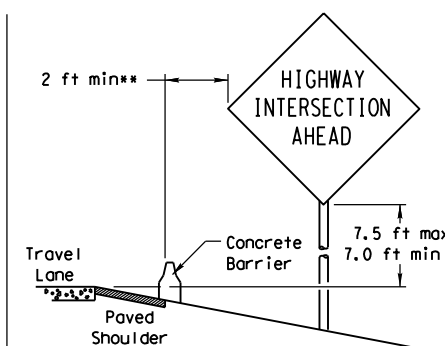

#### BEHIND CONCRETE BARRIER

## TYPICAL SIGN ATTACHMENT DETAIL

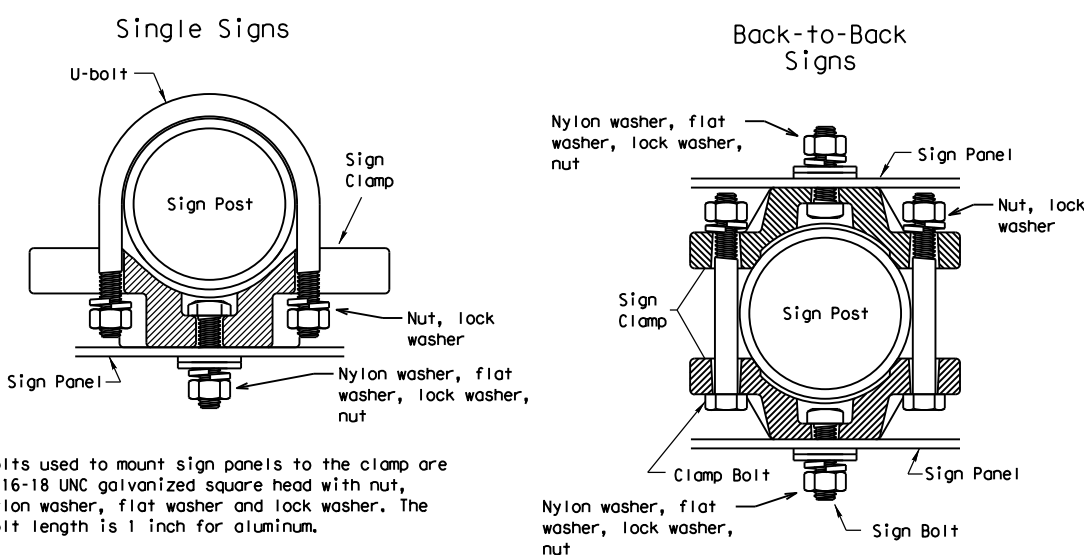

Bolts used to mount sign panels to the clamp are 5/16-18 UNC galvanized square head with nut, nylon washer, flat washer and lock washer. The bolt length is 1 inch for aluminum.

When two sign clamps are used to mount signs back-to-back, use a 5/16-18 UNC galvanized hex head per ASTM A307 with nut and helical-spring lock washer. The approximate bolt lengths for various post sizes and sign clamp types are given in the table at right. The bolt length may need to be adjusted depending upon field conditions.

Sign clamps may be either the specific size clamp or the universal clamp.

Pipe Diameter	Approximate Bolt Length	
	Specific Clamp	Universal Clamp
2" nominal	3"	3 or 3 1/2"
2 1/2" nominal	3 or 3 1/2"	3 1/2 or 4"
3" nominal	3 1/2 or 4"	4 1/2"

### SIGNS WITH PLAQUES

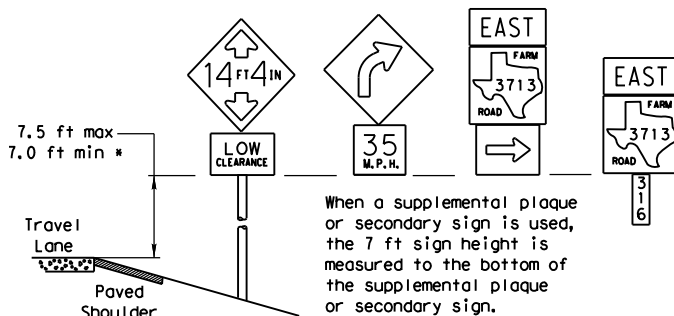

When a supplemental plaque or secondary sign is used, the 7 ft sign height is measured to the bottom of the supplemental plaque or secondary sign.

### CURB & GUTTER OR RAISED ISLAND

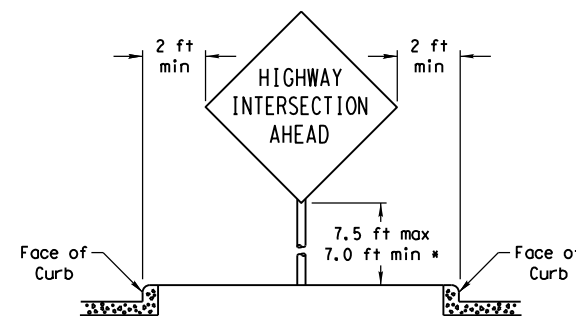

### RESTRICTED RIGHT-OF-WAY (When 6 ft min. is not possible.)

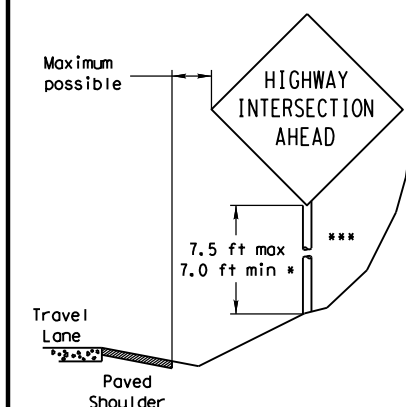

Right-of-way restrictions may be created by rocks, water, vegetation, forest, buildings, a narrow island, or other factors.

In situations where a lateral restriction prevents the minimum horizontal clearance from the edge of the travel lane, signs should be placed as far from the travel lane as practical.

\*\*\* Post may be shorter if protected by guardrail or if Engineer determines the post could not be hit due to extreme slope.

\* Signs shall be mounted using the following condition that results in the greatest sign elevation:

- (1) a minimum of 7 to a maximum of 7.5 feet above the edge of the travel lane or
- (2) a minimum of 7 to a maximum of 7.5 feet above the grade at the base of the support when sign is installed on the backslope.

The maximum values may be increased when directed by the Engineer.

See the Traffic Operations Division website for detailed drawings of sign clamps, Triangular Slipbase System components and Wedge Anchor System components.

The website address is:  
<http://www.txdot.gov/publications/traffic.htm>

Texas Department of Transportation  
Traffic Operations Division

## SIGN MOUNTING DETAILS SMALL ROADSIDE SIGNS GENERAL NOTES & DETAILS

### SMD (GEN) - 08

© TxDOT July 2002		DN: TxDOT	CK: TxDOT	DW: TxDOT	CK: TxDOT
9-08	REVISIONS	CONT	SECT	JOB	HIGHWAY
		0918 00		392	VA
		DIST	COUNTY		SHEET NO.
		DAL	DALLAS, ETC.		40

DATE: 2/14/2024 2:53:19 PM  
UR:\TRAFFIC PROJECTS\0918-00-392 Non-Site 9-24\Microstation Files\040 SMD(GEN)-08.dgn



# TRIANGULAR SLIPBASE INSTALLATION GENERAL REQUIREMENTS

**NOTE**  
The devices shall be installed per manufacturers' recommendations. Installation procedures shall be provided to the Engineer by Contractor.

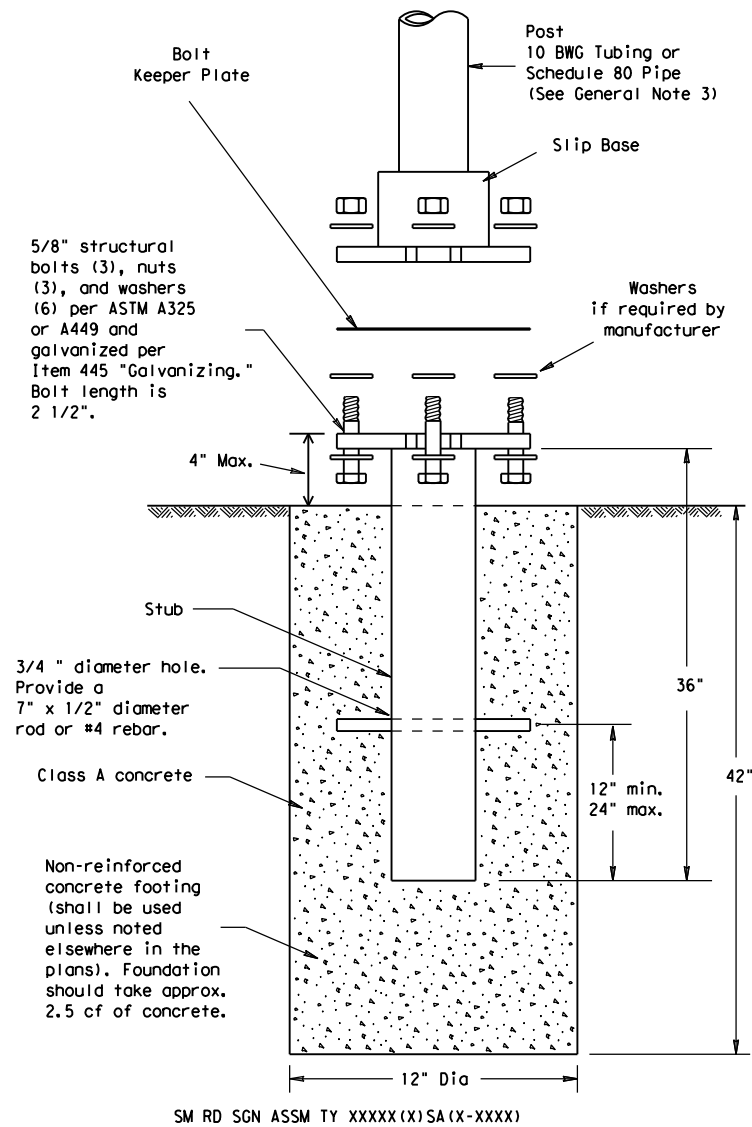

SM RD SGN ASSM TY XXXXX(X)SA(X-XXXX)

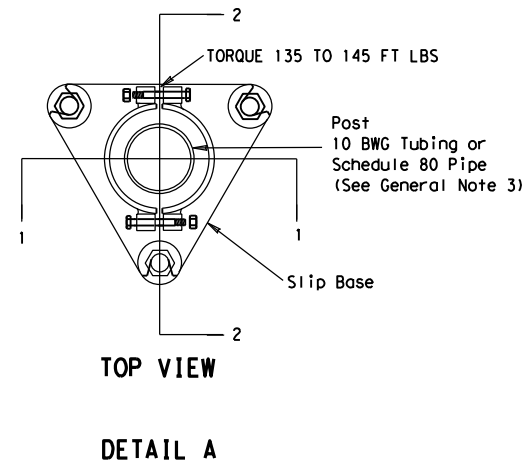
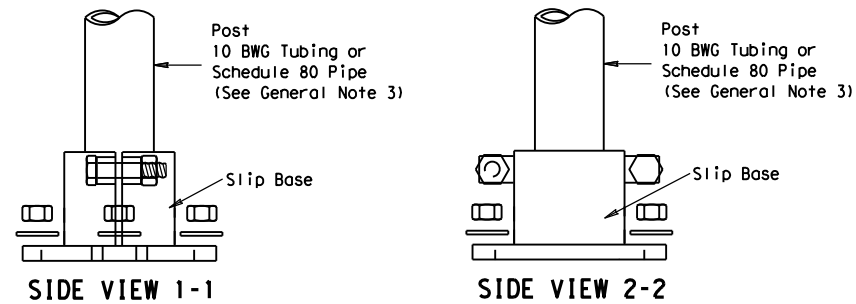

TOP VIEW

DETAIL A

## CONCRETE ANCHOR

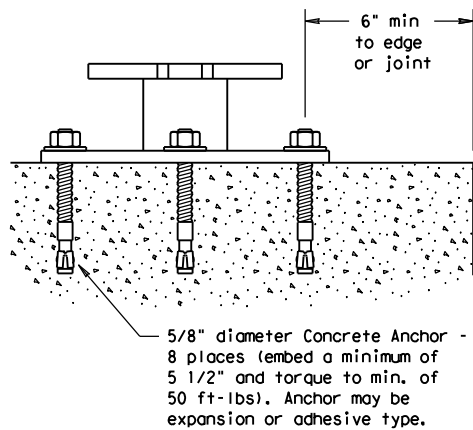

SM RD SGN ASSM TY XXXXX(X)SB(X-XXXX)

## GENERAL NOTES:

- Slip base shall be permanently marked to indicate manufacturer. Method, design, and location of marking are subject to approval of the TxDOT Traffic Standards Engineer.
- Material used as post with this system shall conform to the following specifications:
  - 10 BWG Tubing (2.875" outside diameter)
    - 0.134" nominal wall thickness
    - Seamless or electric-resistance welded steel tubing or pipe
    - Steel shall be HSLAS Gr 55 per ASTM A1011 or ASTM A1008
    - Other steels may be used if they meet the following:
      - 55,000 PSI minimum yield strength
      - 70,000 PSI minimum tensile strength
      - 20% minimum elongation in 2"
    - Wall thickness (uncoated) shall be within the range of 0.122" to 0.138"
    - Outside diameter (uncoated) shall be within the range of 2.867" to 2.883"
    - Galvanization per ASTM A123 or ASTM A653 G210. For precoated steel tubing (ASTM A653), recoat tube outside diameter weld seam by metallizing with zinc wire per ASTM B833.
  - Schedule 80 Pipe (2.875" outside diameter)
    - 0.276" nominal wall thickness
    - Steel tubing per ASTM A500 Gr C
    - Other seamless or electric-resistance welded steel tubing or pipe with equivalent outside diameter and wall thickness may be used if they meet the following:
      - 46,000 PSI minimum yield strength
      - 62,000 PSI minimum tensile strength
      - 21% minimum elongation in 2"
    - Wall thickness (uncoated) shall be within the range of 0.248" to 0.304"
    - Outside diameter (uncoated) shall be within the range of 2.855" to 2.895"
    - Galvanization per ASTM A123
- See the Traffic Operations Division website for detailed drawings of sign clamps and Texas Universal Triangular Slipbase System components. The website address is: <http://www.txdot.gov/publications/traffic.htm>
- Sign supports shall not be spliced except where shown. Sign support posts shall not be spliced.

## ASSEMBLY PROCEDURE

### Foundation

- Prepare 12-inch diameter by 42-inch deep hole. If solid rock is encountered, the depth of the foundation may be reduced such that it is embedded a minimum of 18 inches into the solid rock.
- The Engineer may permit batches of concrete less than 2 cubic yards to be mixed with a portable, motor-driven concrete mixer. For small placements less than 0.5 cubic yards, hand mixing in a suitable container may be allowed by Engineer. Concrete shall be Class A.
- Push the pipe end of the slip base stub into the center of the concrete. Rotate the stub back and forth while pushing it down into the concrete to assure good contact between the concrete and stub. Continue to work the stub into the concrete until it is between 2 to 4 inches above the ground.
- Plumb the stub. Allow a minimum of 4 days to set, unless otherwise directed by the Engineer.
- The triangular slipbase system is multidirectional and is designed to release when struck from any direction.

### Support

- Cut support so that the bottom of the sign will be 7 to 7.5 feet above the edge of the travelway (i.e., edge of the closest lane) when slip plate is below the edge of pavement or 7 to 7.5 feet above slip plate when the slip plate is above the edge of the travelway. The cut shall be plumb and straight.
- Attach sign to support using connections shown. When multiple signs are installed on the same support, ensure the minimum clearance between each sign is maintained. See SMD(SLIP-2) for clearances based on sign types.

ADDED DETAIL A FOR CLAMP BASE  
10-2010



## SIGN MOUNTING DETAILS SMALL ROADSIDE SIGNS TRIANGULAR SLIPBASE SYSTEM SMD(SLIP-1)-08(DAL)

© TxDOT July 2002		DN: TxDOT	CK: TxDOT	DW: TxDOT	CK: TxDOT
9-08	REVISIONS	CONT	SECT	JOB	HIGHWAY
12-10 (DISTRICT)		0918	00	392	VA
ADDED CLAMP BASE DETAIL FOR SLIP BASE INSTALLATION		DIST	COUNTY		SHEET NO.
		DAL	DALLAS, ETC.		41

DISCLAIMER: The use of this standard is governed by the "Texas Engineering Practice Act". No warranty of any kind is made by TxDOT for any purpose whatsoever. TxDOT assumes no responsibility for the conversion of this standard to other formats or for incorrect results or damages resulting from its use.

DATE: 2/14/2024 2:53:59 PM

U:\TRAFFIC PROJECTS\0918-00-392 Non-Site 9-24\Microstation Files\042 SMD(SLIP-2)-08.dgn

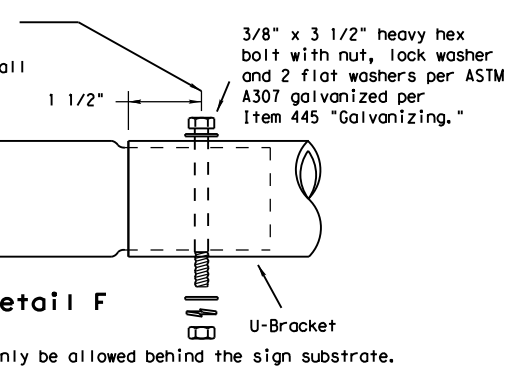
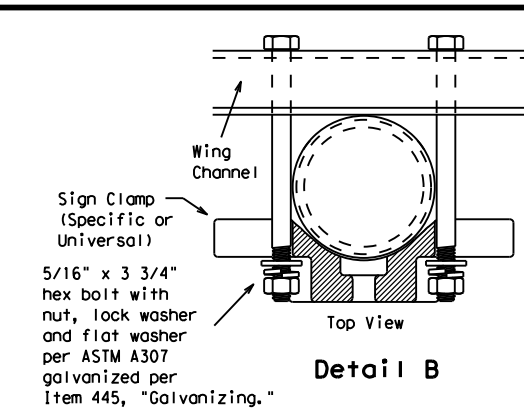
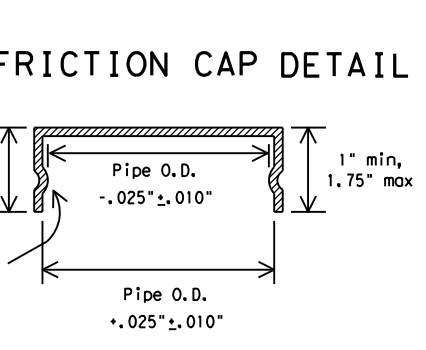
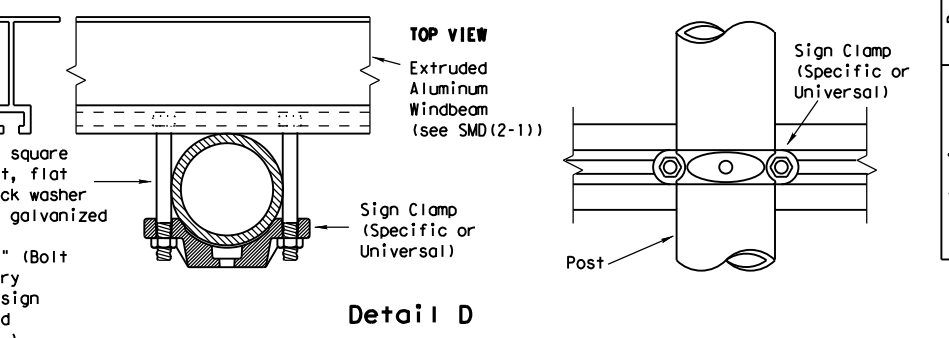
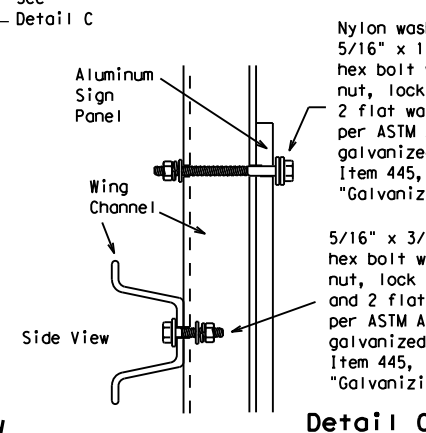
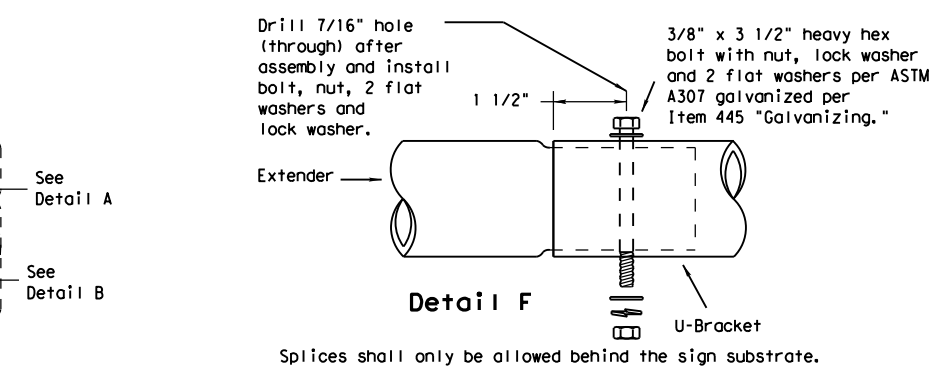
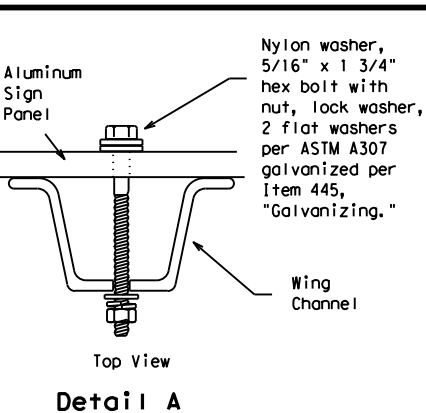
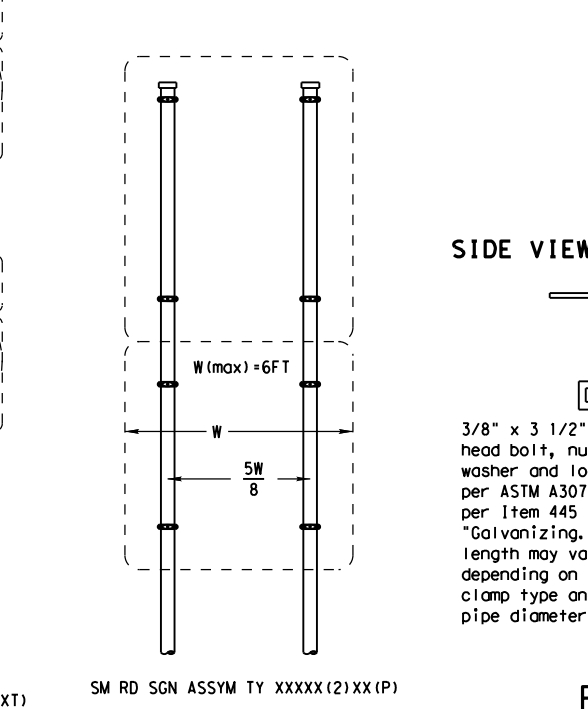
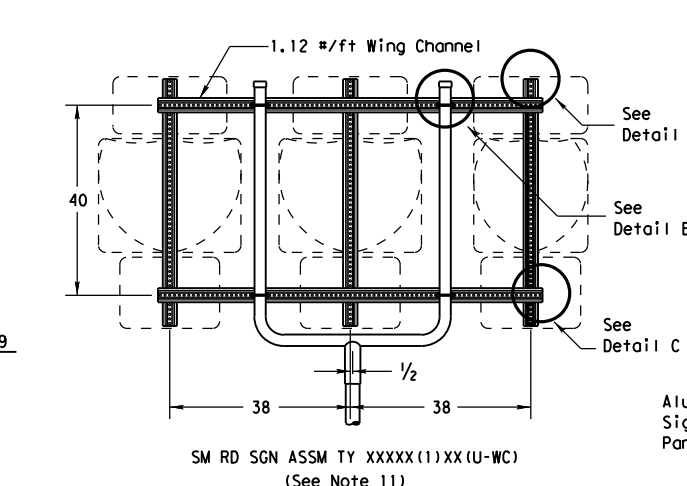
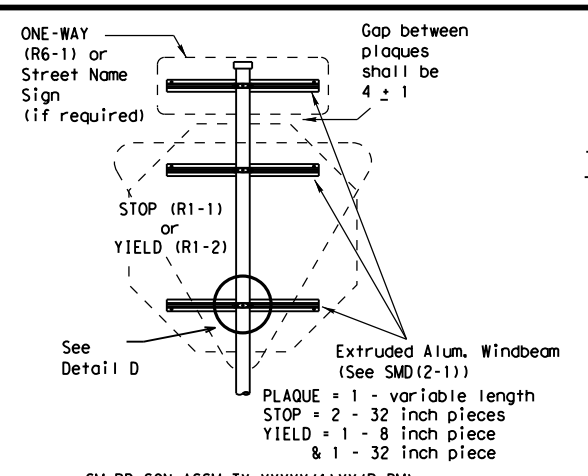
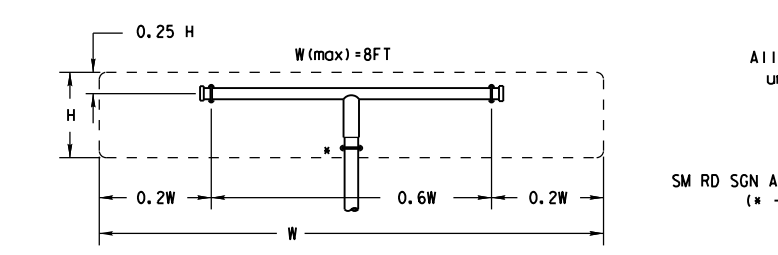
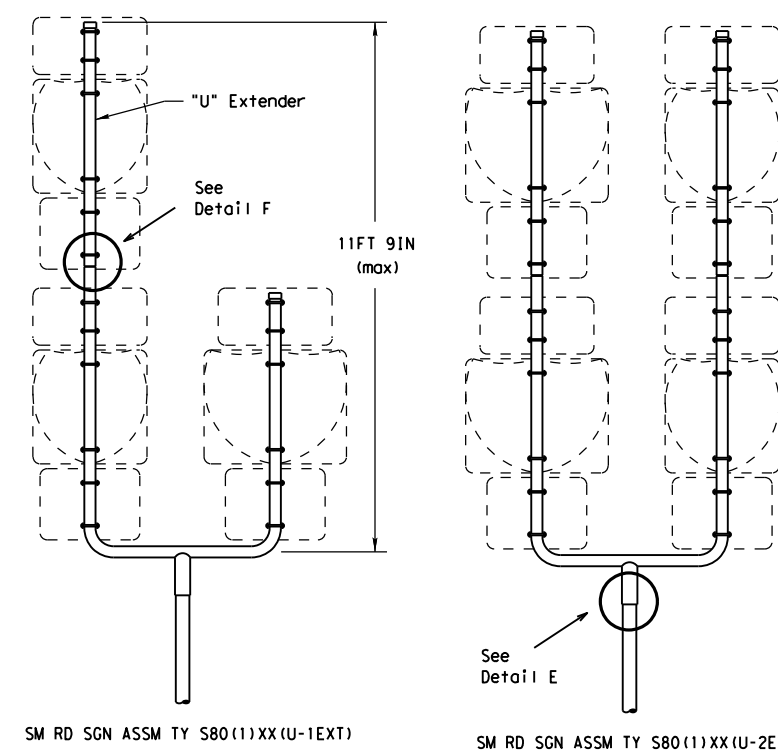
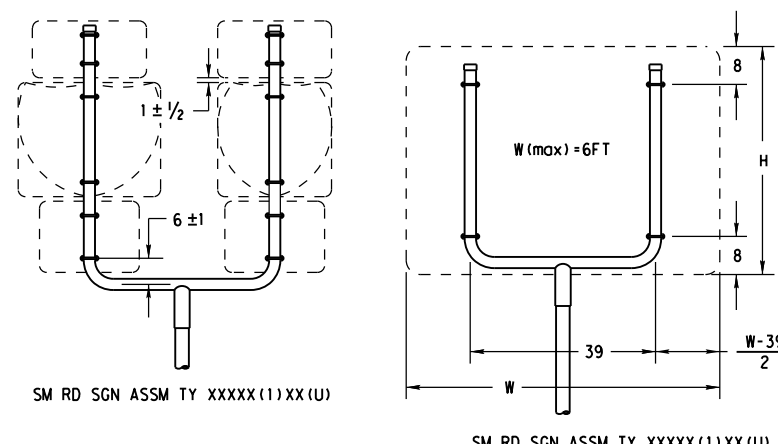
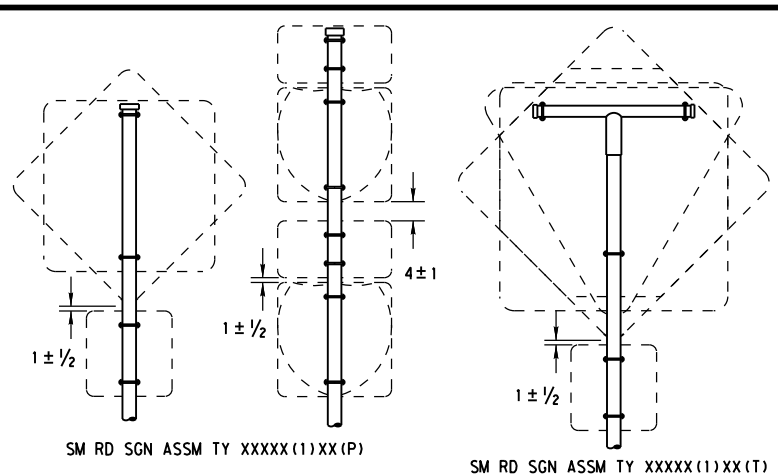

- GENERAL NOTES:**
1. SIGN SUPPORT # OF POSTS MAX. SIGN AREA
  2. The Engineer may require that a Schedule 80 post be used in place of a 10 BWG where a sign height is abnormally high due to a fill slope.
  3. Sign supports shall not be spliced except where shown. Sign support posts shall not be spliced.
  4. Aluminum sign blanks shall conform to Departmental Material Specifications DMS-7110 and shall have the following minimum thicknesses: 0.080 for signs less than 7.5 sq. ft., 0.100 for signs 7.5 to 15 sq. ft., and 0.125 for signs greater than 15 sq. ft.
  5. Signs that require specific supports due to reasons in addition to windloading are indicated on the "REQUIRED SUPPORT" table on this sheet.
  6. For horizontal rectangular signs fabricated from flat aluminum, T-brackets are used for signs 24 inches or less in height. U-brackets are used for signs of greater height.
  7. When two triangular slipbase supports are used to support a single sign, they shall not be "rigidly" connected to each other except through the sign panel. This will allow each support to act independently when impacted by an errant vehicle.
  8. Wing channel shall meet ASTM A 1011 SS Gr 50 and be galvanized per ASTM A 123.
  9. Excess pipe, wing channel, or windbeam shall be cut off so that it does not extend beyond the sign panel (i.e., excess support shall not be visible when the sign is viewed from the front.) Repair galvanized coating at cut support ends per Item 445, "Galvanizing."
  10. Additional route markers may be added vertically, provided the total sign area does not exceed the maximum allowable amount per Note 1.
  11. Additional sign clamp required on the "T-bracket" post for 24 inch height signs. Place the clamp 3 inches above bottom of sign when possible.
  12. Post open ends shall be fitted with Friction Caps.
  13. Sign blanks shall be the sizes and shapes shown on the plans.

REQUIRED SUPPORT		
SIGN DESCRIPTION	SUPPORT	
Regulatory	48-inch STOP sign (R1-1)	TY 10BWG(1)XX(T) TY 10BWG(1)XX(P-BM)
	60-inch YIELD sign (R1-2)	TY 10BWG(1)XX(T) TY 10BWG(1)XX(P-BM)
	48x16-inch ONE-WAY sign (R6-1)	TY 10BWG(1)XX(T) TY 10BWG(1)XX(P-BM)
Warning	36x48, 48x36, and 48x48-inch signs	TY 10BWG(1)XX(T)
	48x60-inch signs	TY S80(1)XX(T)
	48x48-inch signs (diamond or square)	TY 10BWG(1)XX(T)
	48x60-inch signs	TY S80(1)XX(T)
	48-inch Advance School X-ing sign (S1-1)	TY 10BWG(1)XX(T)
48-inch School X-ing sign (S2-1)	TY 10BWG(1)XX(T)	
Large Arrow sign (W1-6 & W1-7)	TY 10BWG(1)XX(T)	

**Texas Department of Transportation**  
Traffic Operations Division

**SIGN MOUNTING DETAILS**  
**SMALL ROADSIDE SIGNS**  
**TRIANGULAR SLIPBASE SYSTEM**  
**SMD (SLIP-2) -08**

© TxDOT July 2002	DN: TXDOT	CK: TXDOT	DW: TXDOT	CK: TXDOT
9-08	REVISIONS	CON: 091800	SECT: 392	JOB: VA
		DIST: DAL	COUNTY: DALLAS, ETC.	SHEET NO.: 42

All dimensions are in english unless detailed otherwise.

Friction caps may be manufactured from hot rolled or cold rolled steel sheets. The minimum sheet metal thickness shall be 24 gauge for all cap sizes. The rim edges shall be reasonably straight and smooth. Caps shall be sized and formed in such a manner as to produce a drive-on friction fit and have no tendency to rock when seated on the pipe. The depth shall be sufficient to give positive protection against entrance of rainwater. They shall be free of sharp creases or indentations and show no evidence of metal fracture. Caps shall have an electrodeposited coating of zinc in accordance with the requirements of ASTM B633 Class FE/ZN 8.

DISCLAIMER: The use of this standard is governed by the "Texas Engineering Practice Act". No warranty of any kind is made by TxDOT for any purpose whatsoever. TxDOT assumes no responsibility for the conversion of this standard to other formats or for incorrect results or damages resulting from its use.

DATE: 2/14/2024 2:54:25 PM  
 U:\TRAFFIC PROJECTS\0918-00-392 Non-Site 9-24\Microstation Files\043 SMD(SLIP-3)-08.dgn

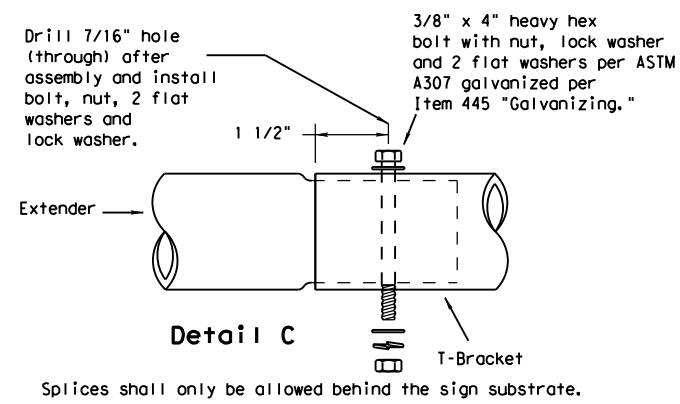
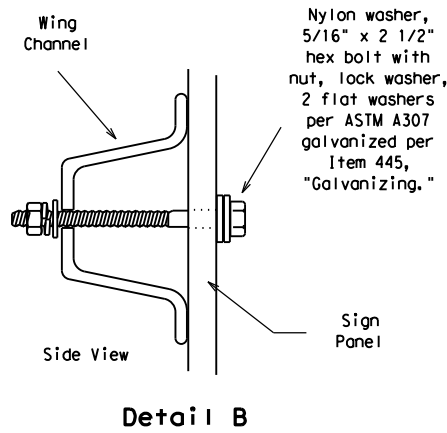
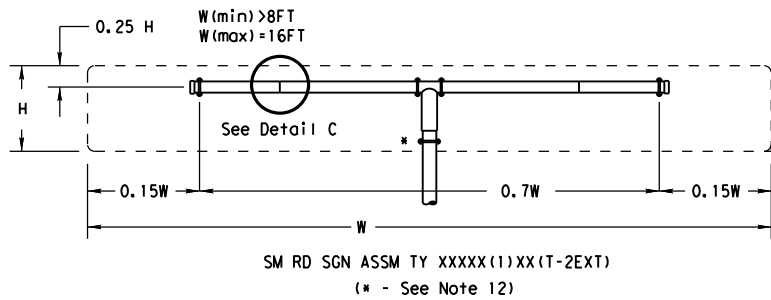

- GENERAL NOTES:**
- | SIGN SUPPORT | # OF POSTS | MAX. SIGN AREA |
|--------------|------------|----------------|
| 10 BWG       | 1          | 16 SF          |
| 10 BWG       | 2          | 32 SF          |
| Sch 80       | 1          | 32 SF          |
| Sch 80       | 2          | 64 SF          |
  - The Engineer may require that a Schedule 80 post be used in place of a 10 BWG where a sign height is abnormally high due to a fill slope.
  - Sign supports shall not be spliced except where shown. Sign support posts shall not be spliced.
  - Aluminum sign blanks shall conform to Departmental Material Specifications DMS-7110 and shall have the following minimum thicknesses: 0.080 for signs less than 7.5 sq. ft., 0.100 for signs 7.5 to 15 sq. ft., and 0.125 for signs greater than 15 sq. ft.
  - Signs that require specific supports due to reasons in addition to windloading are indicated on the "REQUIRED SUPPORT" table on this sheet.
  - For horizontal rectangular signs fabricated from flat aluminum, T-brackets are used for signs 24 inches or less in height. U-brackets are used for signs of greater height.
  - When two triangular slipbase supports are used to support a single sign, they shall not be "rigidly" connected to each other except through the sign panel. This will allow each support to act independently when impacted by an errant vehicle.
  - Wing channel shall meet ASTM A 1011 SS Gr 50 and be galvanized per ASTM A 123.
  - Excess pipe, wing channel, or windbeam shall be cut off so that it does not extend beyond the sign panel (i.e., excess support shall not be visible when the sign is viewed from the front.) Repair galvanized coating at cut support ends per Item 445, "Galvanizing."
  - Sign blanks shall be the sizes and shapes shown on the plans.
  - Additional sign clamp required on the "T-bracket" post for 24 inch high signs. Place the clamp 3 inches above bottom of sign when possible.
  - Post open ends shall be fitted with Friction Caps.

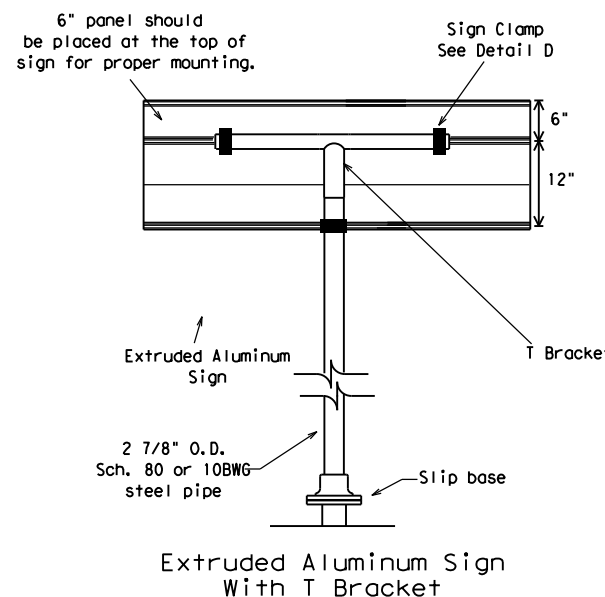
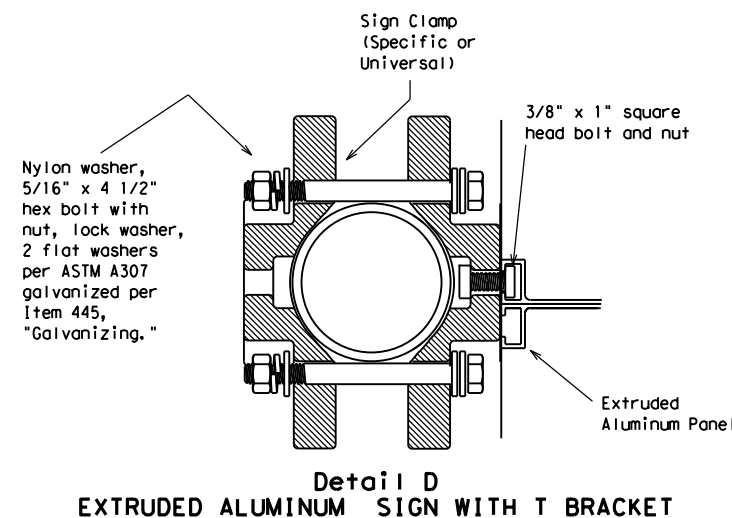
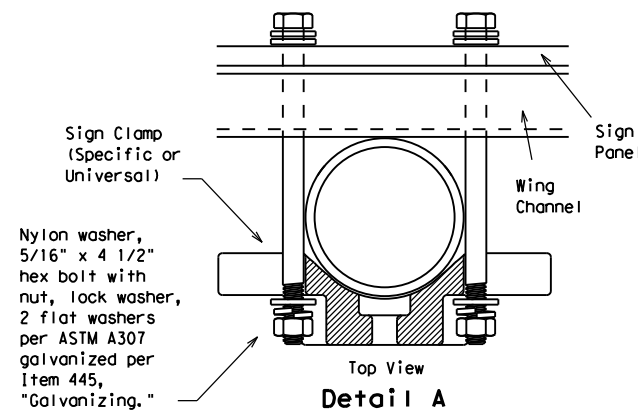
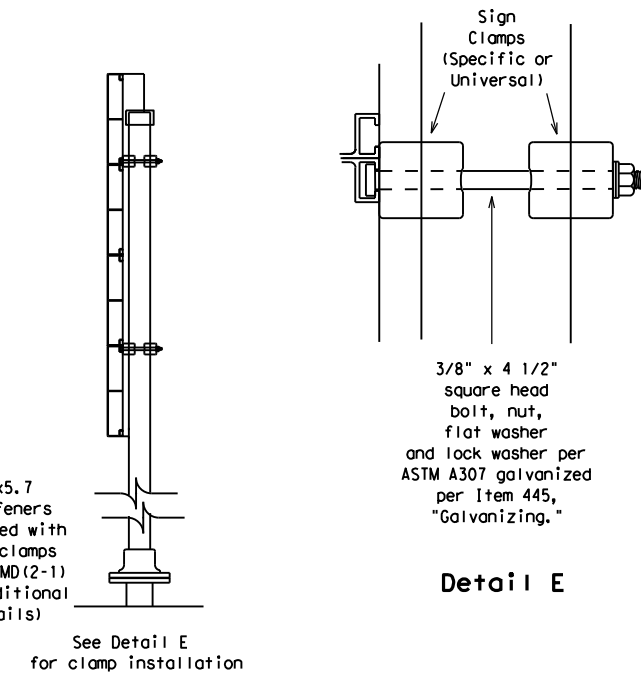
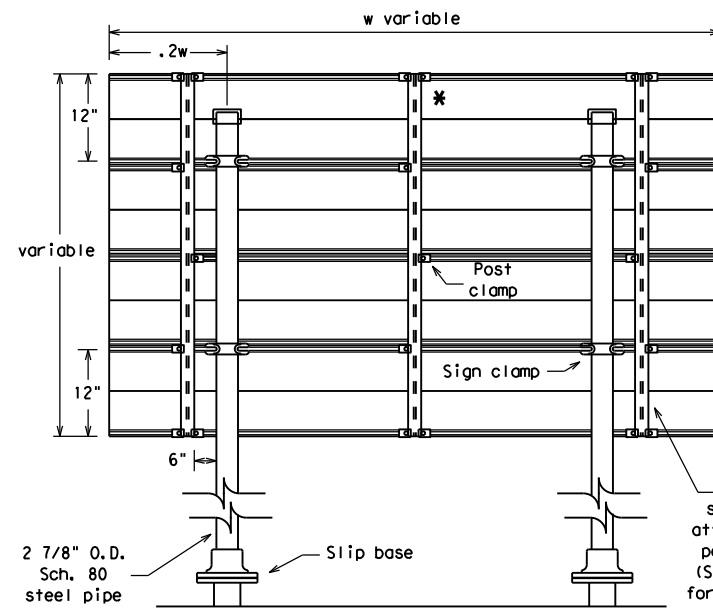
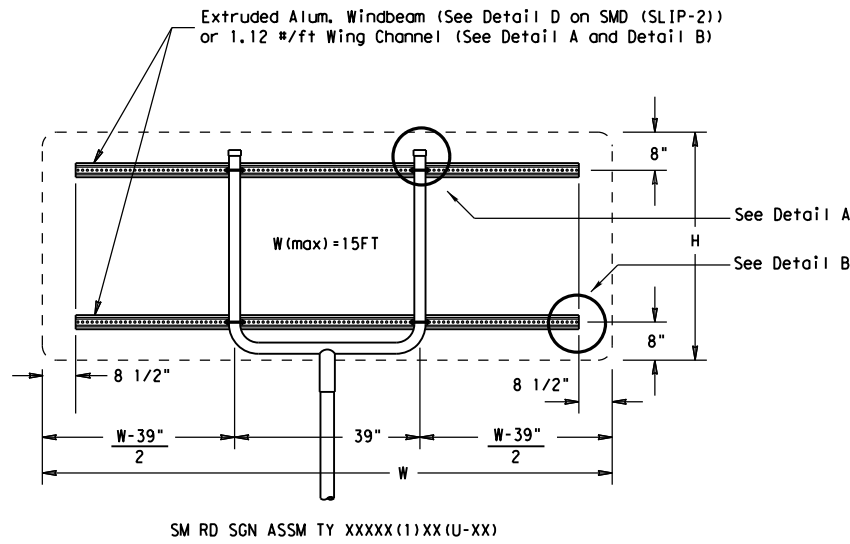

		REQUIRED SUPPORT	
		SIGN DESCRIPTION	SUPPORT
Regulatory	48-inch STOP sign (R1-1)		TY 10BWG(1)XX(T) TY 10BWG(1)XX(P-BM)
	60-inch YIELD sign (R1-2)		TY 10BWG(1)XX(T) TY 10BWG(1)XX(P-BM)
	48x16-inch ONE-WAY sign (R6-1)		TY 10BWG(1)XX(T) TY 10BWG(1)XX(P-BM)
	36x48, 48x36, and 48x48-inch signs		TY 10BWG(1)XX(T)
Warning	48x60-inch signs		TY S80(1)XX(T)
	48x48-inch signs (diamond or square)		TY 10BWG(1)XX(T)
	48x60-inch signs		TY S80(1)XX(T)
	48-inch Advance School X-ing sign (S1-1)		TY 10BWG(1)XX(T)
	48-inch School X-ing sign (S2-1)		TY 10BWG(1)XX(T)
	Large Arrow sign (W1-6 & W1-7)		TY 10BWG(1)XX(T)

Use Extruded Alum. Windbeam as stiffeners See SMD (2-1) for additional details  
 See Detail E for clamp installation

**Texas Department of Transportation**  
 Traffic Operations Division

**SIGN MOUNTING DETAILS**  
**SMALL ROADSIDE SIGNS**  
**TRIANGULAR SLIPBASE SYSTEM**  
**SMD(SLIP-3)-08**

© TxDOT July 2002		DN: TxDOT	CK: TxDOT	DW: TxDOT	CK: TxDOT
9-08	REVISIONS	CONT	SECT	JOB	HIGHWAY
				091800	392
		DIST	COUNTY		SHEET NO.
		DAL	DALLAS, ETC.		43

DISCLAIMER: The use of this standard is governed by the "Texas Engineering Practice Act". No warranty of any kind is made by TxDOT for any purpose whatsoever. TxDOT assumes no responsibility for the conversion of this standard to other formats or for incorrect results or damages resulting from its use.

DATE: 2/14/2024 2:55:49 PM  
 U:\TRAFFIC PROJECTS\0918-00-392 Non-Site 9-24\Microstation Files\044-045 SMA-80-12(Dal).dgn

Arm Length	ROUND POLES					POLYGONAL POLES					Foundation Type
	D <sub>B</sub>	D <sub>19</sub>	D <sub>24</sub>	D <sub>30</sub>	① thk	D <sub>B</sub>	D <sub>19</sub>	D <sub>24</sub>	D <sub>30</sub>	① thk	
ft.	in.	in.	in.	in.	in.	in.	in.	in.	in.	in.	
20	10.5	7.8	7.1	6.3	.179	11.5	8.5	7.7	6.8	.179	30-A
24	11.0	8.3	7.6	6.8	.179	12.0	9.0	8.2	7.3	.179	30-A
28	11.5	8.8	8.1	7.3	.179	12.5	9.5	8.7	7.8	.179	30-A
32	12.5	9.8	9.1	8.3	.179	12.0	9.0	8.2	7.3	.239	30-A
36	12.0	9.3	8.6	7.8	.239	12.5	9.5	8.7	7.8	.239	36-A
40	12.0	9.3	8.6	7.8	.239	13.5	10.5	9.7	8.8	.239	36-A
44	12.5	9.8	9.1	8.3	.239	14.0	11.0	10.2	9.3	.239	36-A
48	13.0	10.3	9.6	8.8	.239	15.0	12.0	11.2	10.3	.239	36-A

Arm Length	ROUND ARMS					POLYGONAL ARMS				
	L <sub>1</sub>	D <sub>1</sub>	D <sub>2</sub>	① thk	Rise	L <sub>1</sub>	D <sub>1</sub>	② D <sub>2</sub>	① thk	Rise
ft.	ft.	in.	in.	in.		ft.	in.	in.	in.	
20	19.1	6.5	3.8	.179	1'-9"	19.1	7.0	3.5	.179	1'-8"
24	23.1	7.5	4.3	.179	1'-10"	23.1	7.5	3.5	.179	1'-9"
28	27.1	8.0	4.2	.179	1'-11"	27.1	8.0	3.5	.179	1'-10"
32	31.0	9.0	4.7	.179	2'-1"	31.0	9.0	3.5	.179	2'-0"
36	35.0	9.5	4.6	.179	2'-4"	35.0	10.0	3.5	.179	2'-1"
40	39.0	9.5	4.1	.239	2'-8"	39.0	9.5	3.5	.239	2'-3"
44	43.0	10.0	4.1	.239	2'-11"	43.0	10.0	3.5	.239	2'-6"
48	47.0	10.5	4.1	.239	3'-4"	47.0	11.0	3.5	.239	2'-9"

- D<sub>B</sub> = Pole Base O.D.
- D<sub>19</sub> = Pole Top O.D. with no Luminaire and no ILSN
- D<sub>24</sub> = Pole Top O.D. with ILSN w/out Luminaire
- D<sub>30</sub> = Pole Top O.D. with Luminaire
- D<sub>1</sub> = Arm Base O.D.
- D<sub>2</sub> = Arm End O.D.
- L<sub>1</sub> = Shaft Length
- L = Nominal Arm Length
- ① Thickness shown are minimums, thicker materials may be used.
- ② D<sub>2</sub> may be increased by up to 1" for polygonal arms.

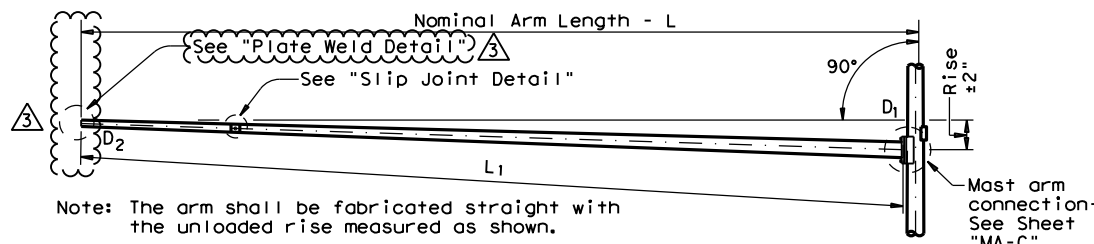

**TRAFFIC SIGNAL ARM**  
(Fixed Mount)

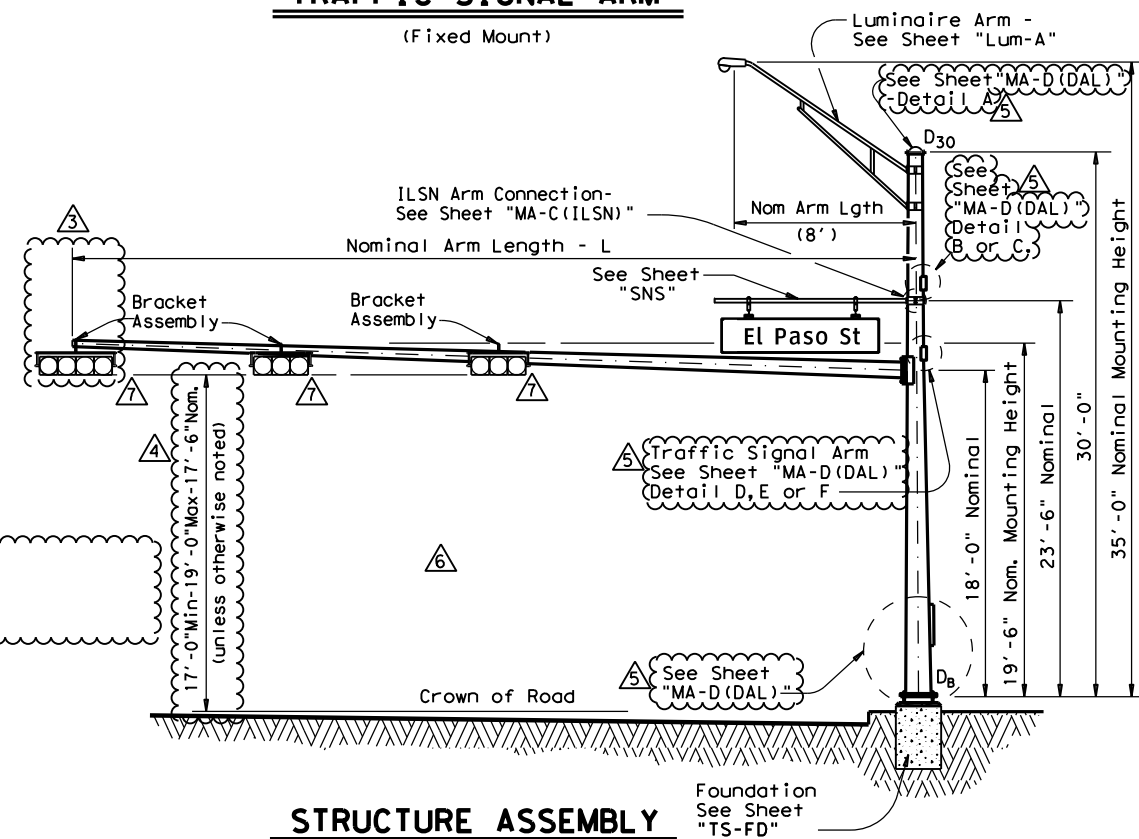

**STRUCTURE ASSEMBLY**

**SHIPPING PARTS LIST**

Ship each pole with the following attached: enlarged hand hole, pole cap, fixed-arm connection bolts and washers and any additional hardware listed in the table.

Nominal Arm Length	30' Poles With Luminaire		24' Poles With ILSN		19' Poles With No Luminaire and No ILSN	
	Designation	Quantity	Designation	Quantity	Designation	Quantity
20	20L-80		20S-80		20-80	
24	24L-80		24S-80		24-80	
28	28L-80		28S-80		28-80	
32	32L-80		32S-80		32-80	
36	36L-80		36S-80		36-80	
40	40L-80		40S-80		40-80	
44	44L-80		44S-80		44-80	
48	48L-80		48S-80		48-80	

Traffic Signal Arms (1 per Pole) Ship each arm with the listed equipment attached

Nominal Arm Length	Type I Arm (1 Signal)		Type II Arm (2 Signals)		Type III Arm (3 Signals)	
	Designation	Quantity	Designation	Quantity	Designation	Quantity
20	20I-80					
24	24I-80		24II-80			
28	28I-80		28II-80			
32			32II-80		32III-80	
36			36II-80		36III-80	
40			40II-80		40III-80	
44			44II-80		44III-80	
48					48III-80	

Luminaire Arms (1 per 30' pole)

Nominal Arm Length	Quantity
8' Arm	

ILSN Arm (Max. 2 per pole) Ship with clamps, bolts and washers

Nominal Arm Length	Quantity
7' Arm	
9' Arm	

Anchor Bolt Assemblies (1 per pole)

Anchor Bolt Diameter	Anchor Bolt Length	Quantity
1 1/2"	3'-4"	
1 3/4"	3'-10"	

Each anchor bolt assembly consists of the following: Top and Bottom templates, 4 anchor bolts, 8 nuts, 8 flat washers, and 4 nut anchor devices (Type 2) per Standard Drawing "TS-FD".

Templates may be removed for shipment.

**MODIFICATIONS:**

- ① REPLACED CGB CONNECTOR WITH BRACKET ASSEMBLY. (2/12)
- ② ADDITIONAL OPTION. (3/12)
- ③ REPLACED TENON DETAIL WITH PLATE WELD DETAIL. (2/12)
- ④ REVISED MINIMUM SIGNAL HEIGHT. (3/12)
- ⑤ REPLACED "MA-D" WITH "MA-D(DAL)". (2/12)
- ⑥ REMOVED TABLE OF DIMENSIONS "A". (2/12)
- ⑦ REMOVED CGB CONNECTORS. (2/12)

Texas Department of Transportation

**TRAFFIC SIGNAL SUPPORT STRUCTURES**

**SINGLE MAST ARM ASSEMBLY**

**(80 MPH WIND ZONE)**

**SMA-80(1)-12(DAL)**

© TxDOT August 1995		DN: MS	CK: JSY	DW: MMF	CK: JSY
REVISIONS		CONT	SECT	JOB	HIGHWAY
5-96	11-99	091800		392	VA
1-12		DIST	COUNTY		SHEET NO.
		DAL	DALLAS, ETC.		44

DISCLAIMER: The use of this standard is governed by the "Texas Engineering Practice Act". No warranty of any kind is made by TxDOT for any purpose whatsoever. TxDOT assumes no responsibility for the conversion of this standard to other formats or for incorrect results or damages resulting from its use.

DATE: 2/14/2024 2:56:15 PM  
 U:\TRAFFIC PROJECTS\0918-00-392 Non-Site 9-24\Microstation Files\044-045 SMA-80-12(Dal).dgn

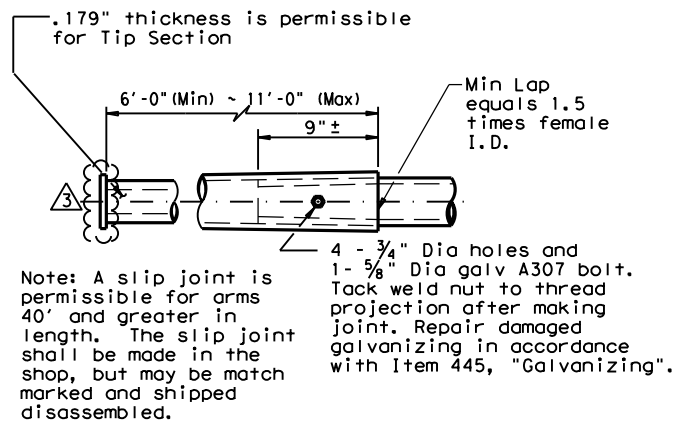

**SLIP JOINT DETAIL**

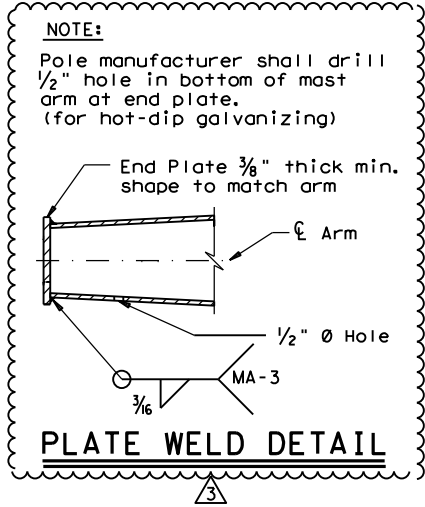

**PLATE WELD DETAIL**

Stainless steel bands (or Cables) and cast bracket as in "Astro-Brac", "Sky Bracket" or "Easy Bracket" with 1 1/2" Dia Threaded Coupling.

**BRACKET ASSEMBLY**

**VIBRATION WARNING**

Mast Arms of SMA and DMA structures and clamp-on Arms of LMA structures of approximately 40 ft or longer are subject to harmonic vertical vibrations in light wind conditions due to the aeroelastic characteristics of a few of the myriads of possible combinations of the following: signal numbers, weights and positions; existence/solidity of backplates; presence of additional attachments to the arm, such as signs and cameras; arm-wind orientation; and arm-pole stiffness.

Such vibrations may cause fatigue damage to the structure and may lead to galloping in moderate wind conditions which may further damage the structure and alarm the public. Tests have indicated that when wind is blowing toward the back side of signal heads having un-vented backplates attached the probability of unacceptable harmonic vibration and/or galloping is rather high.

If backplates are not required for improved visibility they should not be applied to the signal heads or, if they must be applied, they should be vented as a first and inexpensive measure to mitigate vibrations.

The traffic signal mast arms shall be visually inspected in 5 to 20 mph wind conditions after installation of signal heads and any attachments, including any required backplates. If vertical movements with a total excursion (maximum upward excursion to maximum downward excursion) of more than approximately 8" are observed at the arm tip, a damping plate shall be fitted to the arm. See "Damping Plate Mounting Details" on standard sheet, MA-DP-10.

This visual inspection shall be repeated after each modification of the structure that could affect its aeroelastic response. Excessive vibrations shall not be allowed to continue for more than two days.

**GENERAL NOTES:**

Design conforms to 1994 AASHTO Standard Specifications for Structural Supports for Highway Signs, Luminaires, and Traffic Signals and Interim Specifications thereto. Design Wind Speed equals 80 mph plus a 1.3 gust factor.

Poles are designed to support one 8'-0" luminaire arm, one 9'-0" internally lighted street name sign and one traffic signal arm with a length as tabulated. The specified luminaire load applied at the end of the luminaire arm equals 60 lbs vertical dead load plus the horizontal wind load on an effective projected area of 1.6 sq ft. The specified internally lighted street name sign load applied 4.5 ft from the centerline of the pole equals 85 lbs vertical dead load plus horizontal wind load on an effective projected area of 11.5 sq ft. The specified signal load applied at the end of the traffic signal arm equals 180 lbs vertical dead load plus the horizontal wind load on an effective projected area of 32.4 sq ft (actual area times drag coefficient).

See Standard Sheet "MA-D(DAL)" for pole details, "MA-C" for traffic signal arm connection details, "MA-C (ILSN)" for internally lighted street name sign arm connection details, "LUM-A" for luminaire arm and connection details, "SNS" for internally lighted street name sign details, and "TS-FD" for anchor bolt and foundation details. See "MA-C" for material specifications.

Fabrication shall be in accordance with Item 686, "Traffic Signal Pole Assemblies (Steel)" and with the details, dimensions, and weld procedures shown herein. Weld references call for preapproved weld procedures which the Fabricator must obtain prior to fabrication. Materials, fabrication tolerances, and shipping practices shall meet the requirements of this sheet and Item 686, "Traffic Signal Pole Assemblies (Steel)".

Unless otherwise noted, all parts shall be galvanized in accordance with Item 445, "Galvanizing", after fabrication.

Deviation from the details and dimensions shown herein require submission of shop drawings in accordance with Item 441, "Steel Structures". Alternate designs are not acceptable.

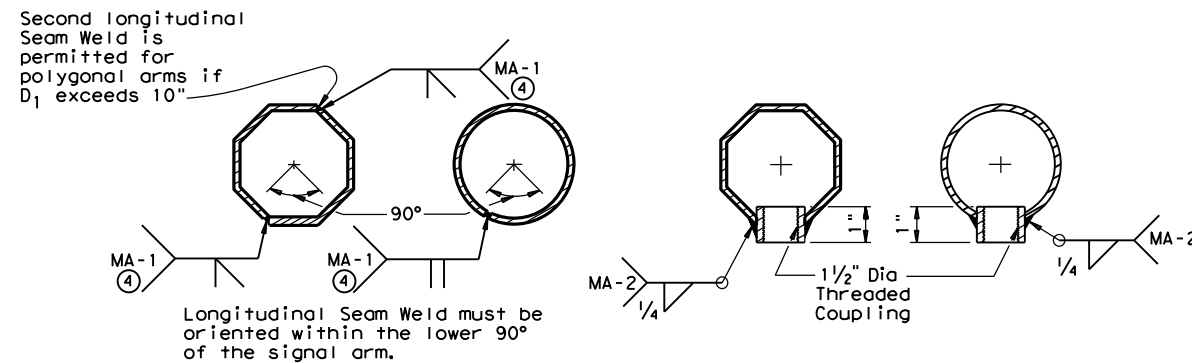

**ARM WELD DETAIL**

**ARM COUPLING DETAILS**

④ 60% Min. penetration  
 100% penetration within  
 6" of circumferential  
 base welds.

REPLACED TENON DETAIL WITH PLATE WELD DETAIL (2/12).  
 REPLACED "MA-D" WITH "MA-D(DAL)" (2/12).

**TRAFFIC SIGNAL SUPPORT STRUCTURES**  
**SINGLE MAST ARM ASSEMBLY**  
**(80 MPH WIND ZONE)**  
**SMA-80(2)-12(DAL)**

© TxDOT August 1995		DN: MS	CK: JSY	DW: MMF	CK: JSY
REVISIONS		CONT	SECT	JOB	HIGHWAY
5-96		091800		392	VA
1-12		DIST	COUNTY		SHEET NO.
		DAL	DALLAS, ETC.		45

DISCLAIMER: The use of this standard is governed by the "Texas Engineering Practice Act". No warranty of any kind is made by TxDOT for any purpose whatsoever. TxDOT assumes no responsibility for the conversion of this standard to other formats or for incorrect results or damages resulting from its use.

DATE: 2/14/2024 2:57:19 PM  
 U:\TRAFFIC PROJECTS\0918-00-392 Non-Site 9-24\Microstation Files\046-048 DMA-80-12 (Dal).dgn

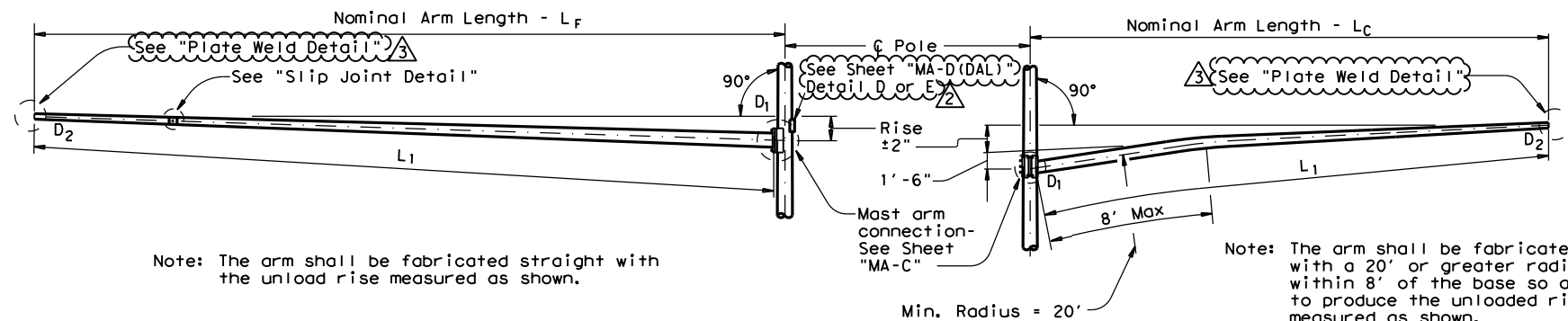

**FIXED MOUNT TRAFFIC SIGNAL ARM**

**CLAMP-ON TRAFFIC SIGNAL ARM**

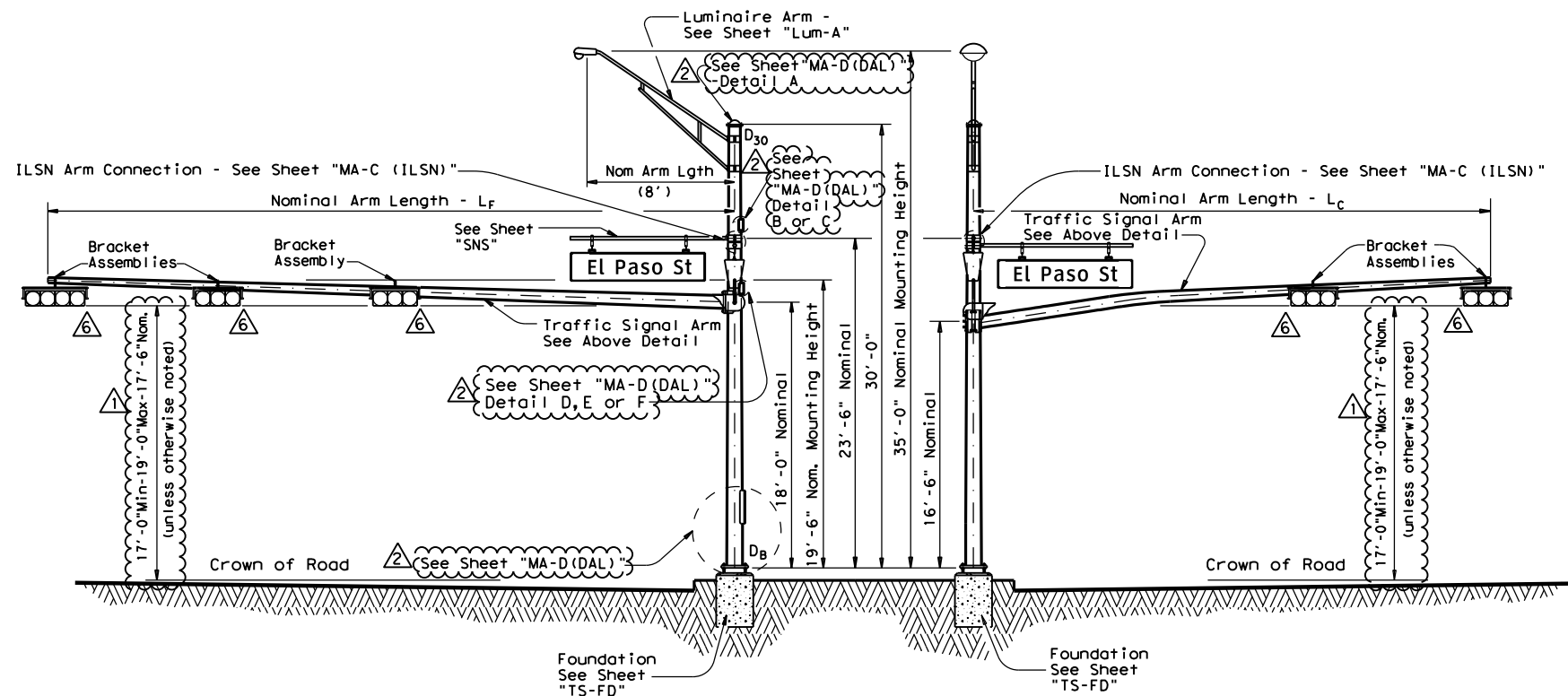

**ELEVATION**

(Showing fixed mount arm)

**STRUCTURE ASSEMBLY**

**ELEVATION**

(Showing clamp mount arm)

**MODIFICATIONS:**

- 1 REVISD MINIMUM SIGNAL HEIGHT. (3/12)
- 2 REPLACED "MA-D" WITH "MA-D(DAL)". (2/12)
- 3 REPLACED TENON DETAIL WITH PLATE WELD DETAIL. (2/12)
- 4 NOT USED
- 5 REMOVED TABLE OF DIMENSIONS "A". (2/12)
- 6 REMOVED CGB CONNECTORS. (2/12)

**GENERAL NOTES:**

Design conforms to 1994 AASHTO Standard Specifications for Structural Supports for Highway Signs, Luminaires, and Traffic Signals and Interim Specifications thereto. Design Wind Speed equals 80 mph plus a 1.3 gust factor. Designs are based on an arm included angle of 90 degrees or more. Angles of less than approximately 75 degrees will require a special design.

Poles are designed to support one 8'-0" luminaire arm, two 9'-0" internally lighted street name signs and two traffic signal arms with length combinations as tabulated. The specified luminaire load applied at the end of luminaire arm equals 60 lbs vertical dead load plus the horizontal wind load on an effective projected area of 1.6 sq ft. The specified internally lighted street name sign applied 4'-6" from the centerline of the pole equals 85 lbs vertical dead load plus the horizontal wind load on an effective projected area of 11.5 sq ft. The specified signal load applied at the end of the traffic signal arm equals 180 lbs vertical dead load plus the horizontal wind load on an effective projected area of 32.4 sq ft (actual area times drag coefficient).

2 See Standard Sheet "MA-D(DAL)" for pole details, "MA-C" for traffic signal arm connection details, "MA-C (ILSN)" for internally lighted street name sign arm connection details, "LUM-A" for luminaire arm and connection details, "SNS" for internally lighted street name sign details, and "TS-FD" for anchor bolt and foundation details. See "MA-C" for material specifications.

Fabrication shall be in accordance with Item 686, "Traffic Signal Pole Assemblies (Steel)" and with the details, dimensions, and weld procedures shown herein. Weld references call for preapproved weld procedures which the Fabricator must obtain prior to fabrication. Materials, fabrication tolerances, and shipping practices shall meet the requirements of this sheet and Item 686, "Traffic Signal Pole Assemblies (Steel)".

Unless otherwise noted, all parts shall be galvanized in accordance with Item 445, "Galvanizing", after fabrication.

Deviation from the details and dimensions shown herein require submission of shop drawings in accordance with Item 441, "Steel Structures". Alternate designs are not acceptable.

**Texas Department of Transportation**

**TRAFFIC SIGNAL SUPPORT STRUCTURES**

**DUAL MAST ARM ASSEMBLY**

**(80 MPH WIND ZONE)**

**DMA-80 (1)-12(DAL)**

© TxDOT August 1995		DN: MS	CK: JSY	DW: MMF	CK: JSY
REVISIONS		CONT	SECT	JOB	HIGHWAY
5-96	1-12	091800		392	VA
		DIST	COUNTY	SHEET NO.	
		DAL	DALLAS, ETC.	46	

The use of this standard is governed by the "Texas Engineering Practice Act". No warranty of any kind is made by TxDOT for any purpose whatsoever. TxDOT assumes no responsibility for the conversion of this standard to other formats or for incorrect results or damages resulting from its use.

DATE: 2/14/2024 2:57:40 PM  
 U:\TRAFFIC PROJECTS\0918-00-392 Non-Site 9-24\Microstation Files\046-048 DMA-80-12 (Dal).dgn

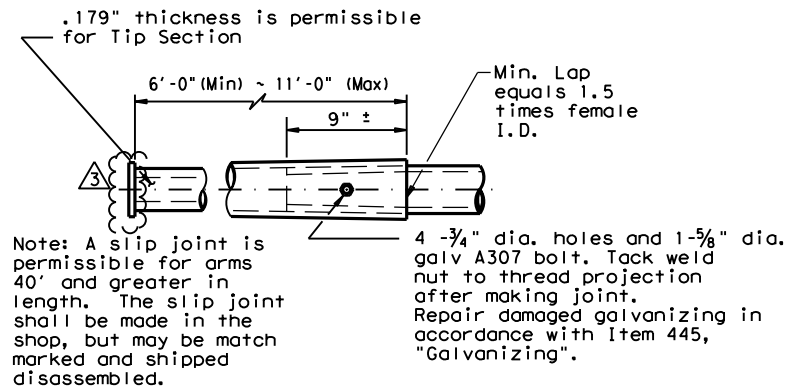

**SLIP JOINT DETAIL**

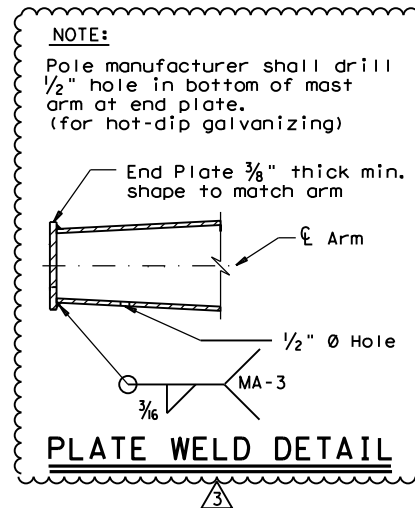

**PLATE WELD DETAIL**

Stainless steel bands (or Cables) and cast bracket as in "Astro-Brac", "Sky Bracket" or "Easy Bracket" with 1 1/2" Dia Threaded Coupling.

**BRACKET ASSEMBLY**

**VIBRATION WARNING**

Mast Arms of SMA and DMA structures and clamp-on Arms of LMA structures of approximately 40 ft or longer are subject to harmonic vertical vibrations in light wind conditions due to the aeroelastic characteristics of a few of the myriads of possible combinations of the following: signal numbers, weights and positions; existence/solidity of backplates; presence of additional attachments to the arm, such as signs and cameras; arm-wind orientation; and arm-pole stiffness.

Such vibrations may cause fatigue damage to the structure and may lead to galloping in moderate wind conditions which may further damage the structure and alarm the public. Tests have indicated that when wind is blowing toward the back side of signal heads having un-vented backplates attached the probability of unacceptable harmonic vibration and/or galloping is rather high.

If backplates are not required for improved visibility they should not be applied to the signal heads or, if they must be applied, they should be vented as a first and inexpensive measure to mitigate vibrations.

The traffic signal mast arms shall be visually inspected in 5 to 20 mph wind conditions after installation of signal heads and any attachments, including any required backplates. If vertical movements with a total excursion (maximum upward excursion to maximum downward excursion) of more than approximately 8" are observed at the arm tip, a damping plate shall be fitted to the arm. See "Damping Plate Mounting Details" on standard sheet, MA-DPD-10.

This visual inspection shall be repeated after each modification of the structure that could affect its aeroelastic response. Excessive vibrations shall not be allowed to continue for more than two days.

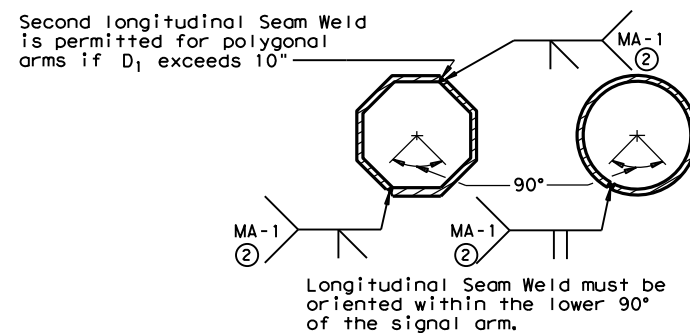

**ARM WELD DETAIL**

② 60% Min. penetration  
 100% penetration within 6" of circumferential base welds.

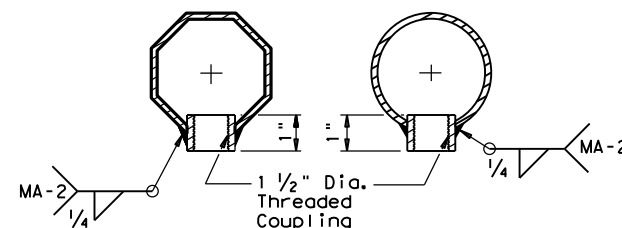

**ARM COUPLING DETAILS**

REPLACED TENON DETAIL WITH PLATE WELD DETAIL (2/12).

**Texas Department of Transportation**

**TRAFFIC SIGNAL SUPPORT STRUCTURES**

**DUAL MAST ARM ASSEMBLY**

**(80 MPH WIND ZONE)**

**DMA-80 (2) - 12 (DAL)**

© TxDOT August 1995		DN: MS	CK: JSY	DW: MMF	CK: JSY
REVISIONS		CONT	SECT	JOB	HIGHWAY
5-96	1-12	091800		392	VA
		DIST	COUNTY		SHEET NO.
		DAL	DALLAS, ETC.		47

DISCLAIMER: The use of this standard is governed by the "Texas Engineering Practice Act". No warranty of any kind is made by TxDOT for any purpose whatsoever. TxDOT assumes no responsibility for the conversion of this standard to other formats or for incorrect results or damages resulting from its use.

DATE: 2/14/2024 2:57:59 PM  
 U:\TRAFFIC PROJECTS\0918-00-392 Non-Site 9-24\Microstation Files\046-048 DMA-80-12 (Dal).dgn

### SHIPPING PARTS LIST

Ship each pole with the following attached: enlarged hand hole, pole cap, fixed arm connection bolts and washers and any additional hardware listed in the table.

Nominal Arm Length	30' Poles With Luminaire		24' Poles With ILSN		19' Poles With no Luminaire and no ILSN	
	LF	Lc	Designation	Quantity	Designation	Quantity
20	20	2020L-80		2020S-80		2020-80
24	20	2420L-80		2420S-80		2420-80
24	24	2424L-80		2424S-80		2424-80
28	20	2820L-80		2820S-80		2820-80
28	24	2824L-80		2824S-80		2824-80
28	28	2828L-80		2828S-80		2828-80
32	20	3220L-80		3220S-80		3220-80
32	24	3224L-80		3224S-80		3224-80
32	28	3228L-80		3228S-80		3228-80
32	32	3232L-80		3232S-80		3232-80
36	20	3620L-80		3620S-80		3620-80
36	24	3624L-80		3624S-80		3624-80
36	28	3628L-80		3628S-80		3628-80
36	32	3632L-80		3632S-80		3632-80
36	36	3636L-80		3636S-80		3636-80
40	20	4020L-80		4020S-80		4020-80
40	24	4024L-80		4024S-80		4024-80
40	28	4028L-80		4028S-80		4028-80
40	32	4032L-80		4032S-80		4032-80
40	36	4036L-80		4036S-80		4036-80
44	20	4420L-80		4420S-80		4420-80
44	24	4424L-80		4424S-80		4424-80
44	28	4428L-80		4428S-80		4428-80
44	32	4432L-80		4432S-80		4432-80
44	36	4436L-80		4436S-80		4436-80

Traffic Signal Arms (Fixed Mount) (1 per pole) Ship each arm w/ the listed equipment attached

Nominal Arm Length	Type I Arm (1 Signal)		Type II Arm (2 Signals)		Type III Arm (3 Signals)	
	ft.	Designation	Designation	Quantity	Designation	Quantity
20	20	20I-80				
24	24	24I-80	24II-80			
28	28	28I-80	28II-80			
32			32II-80		32III-80	
36			36II-80		36III-80	
40			40II-80		40III-80	
44			44II-80		44III-80	

Traffic Signal Arms (Clamp-On Mount) (1 per pole) Ship each arm w/ the listed equipment attached

Nominal Arm Length	Type I Arm (1 Signal)		Type II Arm (2 Signals)		Type III Arm (3 Signals)	
	ft.	Designation	Designation	Quantity	Designation	Quantity
20	20	20I-80	20II-80			
24	24	24I-80	24II-80			
28	28	28I-80	28II-80			
32			32II-80		32III-80	
36			36II-80		36III-80	

Luminaire Arms (1 per 30' pole)

Nominal Arm Length	Quantity
8' Arm	

ILSN Arm (1 or 2 per pole) ship with clamps, bolts and washers

Nominal Arm Length	Quantity
7' Arm	
9' Arm	

Anchor Bolt Assemblies (1 per pole)

Anchor Bolt Diameter	Anchor Bolt Length	Quantity
1 1/2"	3'-4"	
1 3/4"	3'-10"	
2"	4'-3"	

Each anchor bolt assembly consists of the following: Top and Bottom templates, 4 anchor bolts, 8 nuts, 8 flat washers, and 4 nut anchor devices (Type 2) per Standard Drawing "TS-FD".

Templates may be removed for shipment.

LF	Lc	ROUND POLES					POLYGONAL POLES					Foundation Type
		D <sub>B</sub>	D <sub>19</sub>	D <sub>24</sub>	D <sub>30</sub>	③ thk	D <sub>B</sub>	D <sub>19</sub>	D <sub>24</sub>	D <sub>30</sub>	③ thk	
20	20	11.5	8.8	8.1	7.3	.179	12.5	9.5	8.7	7.8	.179	30-A
24	20	12.0	9.3	8.6	7.8	.179	13.0	10.0	9.2	8.3	.179	30-A
24	24	12.0	9.3	8.6	7.8	.179	13.0	10.0	9.2	8.3	.239	30-A
28	20	12.5	9.8	9.1	8.3	.179	12.0	9.0	8.2	7.3	.239	30-A
28	24	12.5	9.8	9.1	8.3	.179	12.0	9.0	8.2	7.3	.239	30-A
28	28	13.0	10.3	9.6	8.8	.179	12.5	9.5	8.7	7.8	.239	30-A
32	20	13.0	10.3	9.6	8.8	.179	12.5	9.5	8.7	7.8	.239	30-A
32	24	13.0	10.3	9.6	8.8	.179	12.5	9.5	8.7	7.8	.239	30-A
32	28	12.0	9.3	8.6	7.8	.239	13.0	10.0	9.2	8.3	.239	30-A
32	32	12.0	9.3	8.6	7.8	.239	13.5	10.5	9.7	8.8	.239	36-A
36	20	12.0	9.3	8.6	7.8	.239	13.5	10.5	9.7	8.8	.239	36-A
36	24	12.0	9.3	8.6	7.8	.239	13.5	10.5	9.7	8.8	.239	36-A
36	28	12.5	9.8	9.1	8.3	.239	13.5	10.5	9.7	8.8	.239	36-A
36	32	12.5	9.8	9.1	8.3	.239	13.5	10.5	9.7	8.8	.239	36-A
40	20	12.5	9.8	9.1	8.3	.239	14.0	11.0	10.2	9.3	.239	36-A
40	24	12.5	9.8	9.1	8.3	.239	14.0	11.0	10.2	9.3	.239	36-A
40	28	13.0	10.3	9.6	8.8	.239	14.0	11.0	10.2	9.3	.239	36-A
40	32	13.0	10.3	9.6	8.8	.239	15.0	12.0	11.2	10.3	.239	36-A
40	36	13.5	10.8	10.1	9.3	.239	15.0	12.0	11.2	10.3	.239	36-A
44	20	13.5	10.8	10.1	9.3	.239	15.0	12.0	11.2	10.3	.239	36-A
44	24	13.5	10.8	10.1	9.3	.239	15.0	12.0	11.2	10.3	.239	36-A
44	28	13.5	10.8	10.1	9.3	.239	15.0	12.0	11.2	10.3	.239	36-A
44	32	14.0	11.3	10.6	9.8	.239	15.5	12.5	11.7	10.8	.239	36-B
44	36	14.0	11.3	10.6	9.8	.239	15.5	12.5	11.7	10.8	.239	36-B

Arm LF or LC	ROUND ARMS					POLYGONAL ARMS				
	L <sub>1</sub>	D <sub>1</sub>	D <sub>2</sub>	③ thk	Rise	L <sub>1</sub>	D <sub>1</sub>	④ D <sub>2</sub>	③ thk	Rise
20	19.1	6.5	3.8	.179	1'-9"	19.1	7.0	3.5	.179	1'-8"
24	23.1	7.5	4.3	.179	1'-10"	23.1	7.5	3.5	.179	1'-9"
28	27.1	8.0	4.2	.179	1'-11"	27.1	8.0	3.5	.179	1'-10"
32	31.0	9.0	4.7	.179	2'-1"	31.0	9.0	3.5	.179	2'-0"
36	35.0	9.5	4.6	.179	2'-4"	35.0	10.0	3.5	.179	2'-1"
40	39.0	9.5	4.1	.239	2'-8"	39.0	9.5	3.5	.239	2'-3"
44	43.0	10.0	4.1	.239	2'-11"	43.0	10.0	3.5	.239	2'-6"

D<sub>B</sub> = Pole Base O.D.  
 D<sub>19</sub> = Pole Top O.D. with no Luminaire and no ILSN  
 D<sub>24</sub> = Pole Top O.D. with ILSN w/out Luminaire  
 D<sub>30</sub> = Pole Top O.D. with Luminaire

D<sub>1</sub> = Arm Base O.D.  
 D<sub>2</sub> = Arm End O.D.  
 L<sub>1</sub> = Shaft Length  
 LF = Fixed Arm Length  
 LC = Clamp-on Arm Length (36" Max)

- ③ Thickness shown are minimums, thicker materials may be used.
- ④ D<sub>2</sub> may be increased by up to 1.0" for polygonal arms.

⚠ REPLACED CGB CONNECTOR WITH BRACKET ASSEMBLY (2/12).

⚠ ADDITIONAL OPTION (2/12).

**Texas Department of Transportation**

**TRAFFIC SIGNAL SUPPORT STRUCTURES**

**DUAL MAST ARM ASSEMBLY**

**(80 MPH WIND ZONE)**

**DMA-80 (3) - 12 (DAL)**

© TxDOT August 1995	DN: MS	CK: JSY	DW: MMF	CK: JSY
REVISIONS	CONT	SECT	JOB	HIGHWAY
5-96 1-12	091800	392	VA	VA
	DIST	COUNTY	SHEET NO.	
	DAL	DALLAS, ETC.	48	



DISCLAIMER: The use of this standard is governed by the "Texas Engineering Practice Act". No warranty of any kind is made by TxDOT for any purpose whatsoever. TxDOT assumes no responsibility for the conversion of this standard to other formats or for incorrect results or damages resulting from its use.

DATE: 2/14/2024 2:59:08 PM  
 U:\TRAFFIC PROJECTS\0918-00-392 Non-Site 9-24\Microstation Files\049-053 LMA-12(Dal).dgn

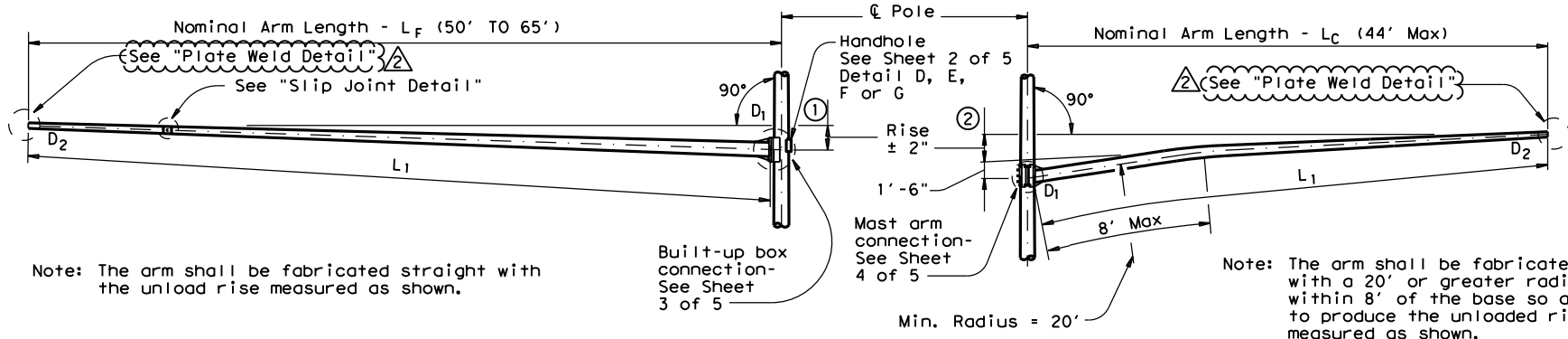

Note: The arm shall be fabricated straight with the unload rise measured as shown.

Note: The arm shall be fabricated with a 20' or greater radius within 8' of the base so as to produce the unloaded rise measured as shown.

**FIXED MOUNT TRAFFIC SIGNAL ARM**

① See Sheet 3 of 5 for Arm Rise

**CLAMP-ON TRAFFIC SIGNAL ARM (IF REQUIRED)**

② See Sheet 4 of 5 for Arm Rise and Clamp-on Arm Details

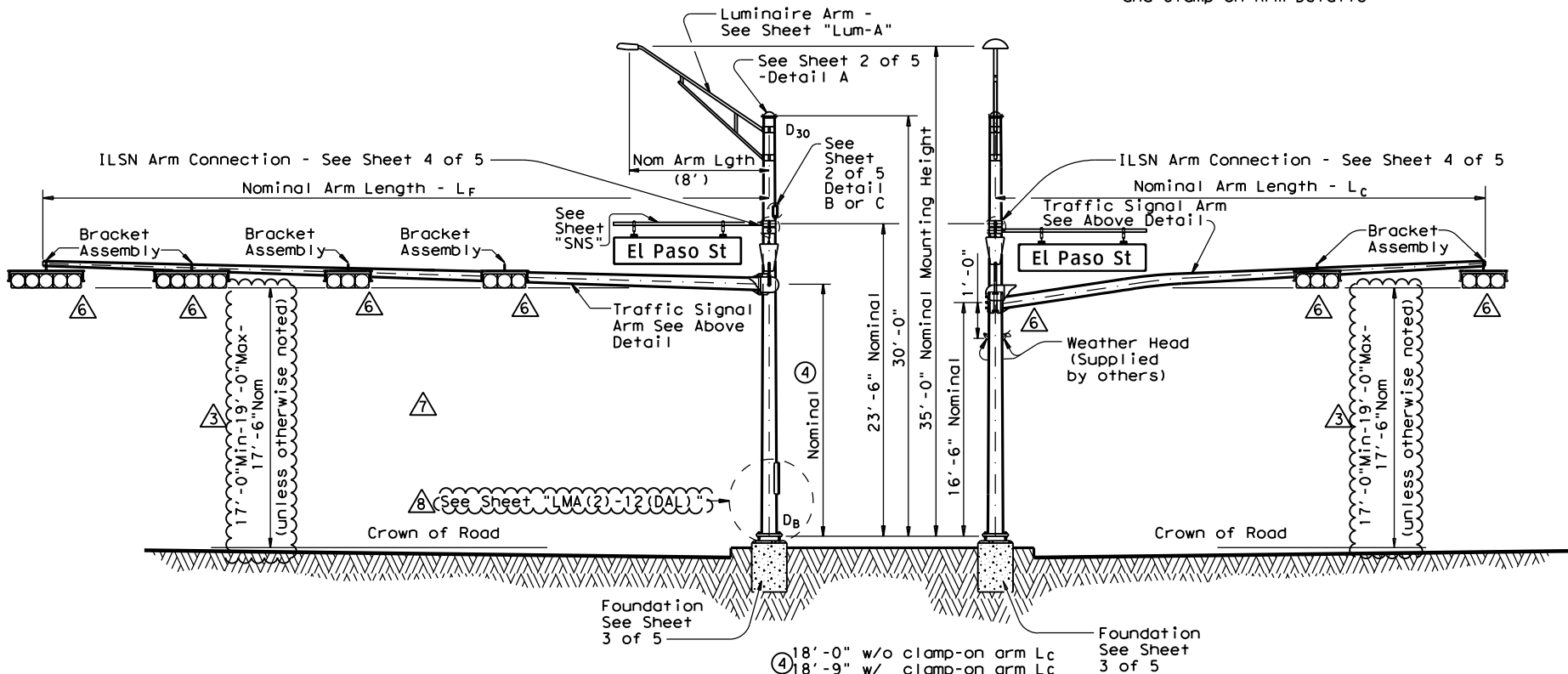

**ELEVATION**

(Showing fixed mount arm)

**STRUCTURE ASSEMBLY**

**ELEVATION**

(Showing clamp-on arm)

- MODIFICATIONS:**
- ① NOT USED
  - ② REPLACED TENON DETAIL WITH PLATE WELD DETAIL. (2/12)
  - ③ REVISED MINIMUM SIGNAL HEIGHT. (3/12)
  - ④ REMOVED "MA-D" REFERENCE. (2/12)
  - ⑤ REMOVED TABLE OF DIMENSIONS "A". (2/12)
  - ⑥ REMOVED CGB CONNECTORS. (2/12)
  - ⑦ REMOVED THREADED COUPLING FOR CGB CONNECTOR. (2/12)
  - ⑧ REVISED THE ELEVATION OF ACCESS COMPARTMENT. (3/12)

**NOTE:**  
 Pole manufacturer shall drill 1/2" hole in bottom of mast arm at end plate.  
 (for hot-dip galvanizing)

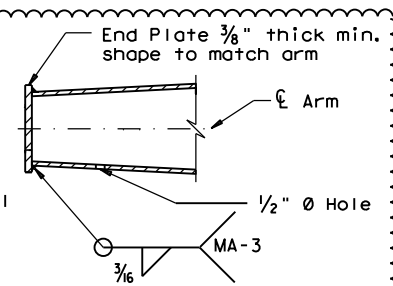

**PLATE WELD DETAIL**

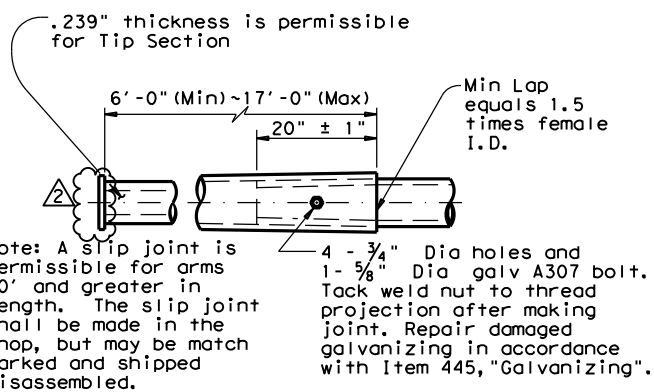

**SLIP JOINT DETAIL (FIXED MOUNT ARM)**

**GENERAL NOTES:**

Design conforms to 1994 AASHTO Standard Specifications for Structural Supports for Highway Signs, Luminaires, and Traffic Signals and Interim Specifications thereto. Design Wind Speed can be either 100 mph or 80 mph plus a 1.3 gust factor. If clamp-on traffic signal is required, designs are based on an arm included angle of 90 degrees or more. Angles of less than approximately 75 degrees will require a special design.

Poles are designed to support one 8'-0" luminaire arm, two 9'-0" internally lighted street name (ILSN) signs and two traffic signal arms with limited length combinations.

Each arm with its related attachment is shown below

Arm	Equivalent DL ⑤	WL EPA ⑤⑥
8' Luminaire Arm	Luminaire 60 lbs	1.6 sq ft
9' ILSN Arm	Sign 85 lbs	11.5 sq ft
50' to 65' Fixed Mount Arm	Signal Loads 310 lbs	52 sq ft
Up to 44' Clamp-on Arm	Signal Loads 180 lbs	32.4 sq ft

⑤ Equivalent dead load plus horizontal wind load applied at the end of arm except ILSN arm, which applied 4.5' from the centerline of the pole.

⑥ Effective projected area (actual area times drag coefficient) for the application of horizontal wind load.

Except as noted in Sheet 1 thru 5 of 5, other details not covered shall refer to Standard Sheet "LUM-A" for luminaire arm and connection details, "SNS" for internally lighted street name sign details, and "TS-FD" for anchor bolt and foundation details.

Fabrication shall be in accordance with Item 686, "Traffic Signal Pole Assemblies (Steel)" and with the details, dimensions, and weld procedures shown herein. Weld references call for preapproved weld procedures which the Fabricator must obtain prior to fabrication. Material, fabrication tolerances, and shipping practices shall also meet the requirements of this sheet and Item 686, "Traffic Signal Pole Assemblies (Steel)".

Unless otherwise noted, all parts shall be galvanized in accordance with Item 445, "Galvanizing" after fabrication.

Deviations from the details and dimensions shown herein require submission of shop drawings in accordance with the Item 441, "Steel Structures". Alternate designs are not acceptable.

Installation of damping plate for the long mast arm is not recommended.

Provision of the bracket assembly used to support the traffic signal heads shall be under the direction of the Engineer for approval.

Design also conforms to NCHRP Report 412 for fatigue resistance except that there are no stiffeners at the base plate. TxDOT is conducting tests to determine if stiffeners at the base plate will or will not result in optimal performance; depending upon the results of the tests, poles may need a retrofit to ensure optimal fatigue performance.



**TRAFFIC SIGNAL SUPPORT STRUCTURES LONG MAST ARM ASSEMBLY (50 TO 65 FT) (80 AND 100 MPH WIND ZONE) LMA(1)-12(DAL)**

Sheet 1 of 5

© TxDOT July 2000		DN: TxDOT	CK: TxDOT	DW: TxDOT	CK: TxDOT
4-20-01	REVISIONS	CONT	SECT	JOB	HIGHWAY
1-12		091800		392	VA
		DIST	COUNTY		SHEET NO.
		DAL	DALLAS, ETC.		49

DISCLAIMER: The use of this standard is governed by the "Texas Engineering Practice Act". No warranty of any kind is made by TxDOT for any purpose whatsoever. TxDOT assumes no responsibility for the conversion of this standard to other formats or for incorrect results or damages resulting from its use.

DATE: 2/14/2024 2:59:26 PM  
 U:\TRAFFIC PROJECTS\0918-00-392 Non-Site 9-24\Microstation Files\049-053 LMA-12(Dal).dgn

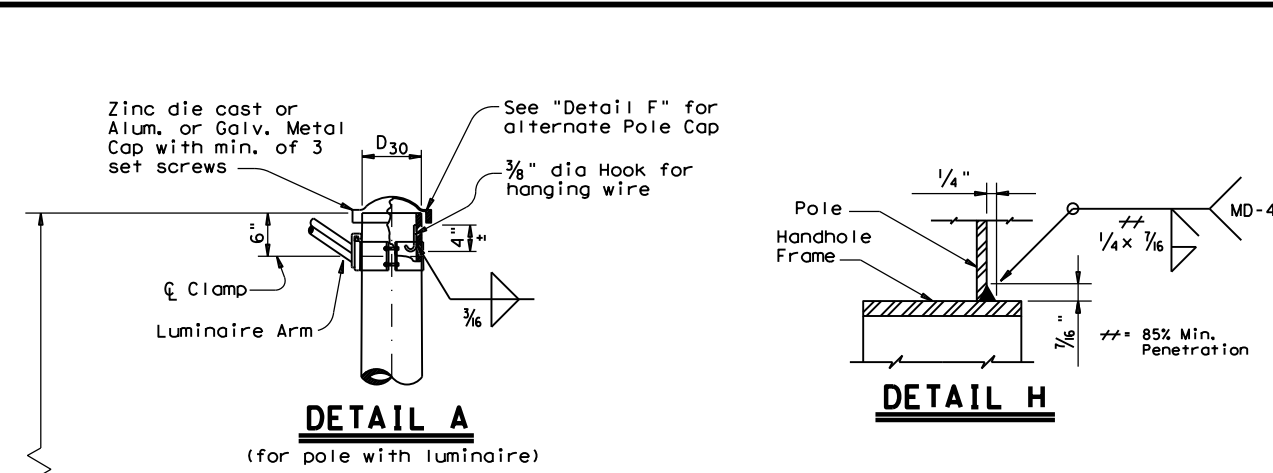

**DETAIL A**  
(for pole with luminaire)

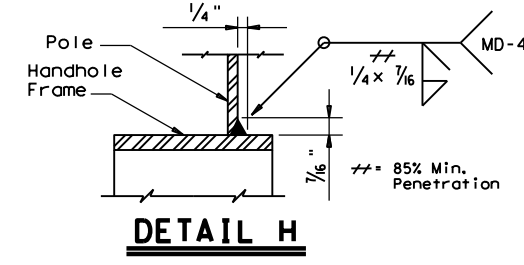

**DETAIL H**

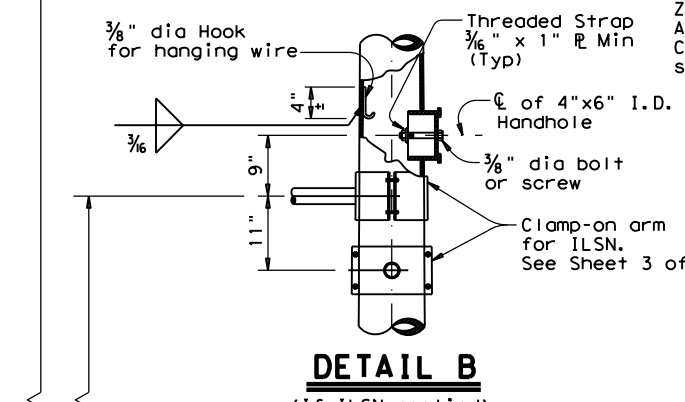

**DETAIL B**  
(If ILSN applied)

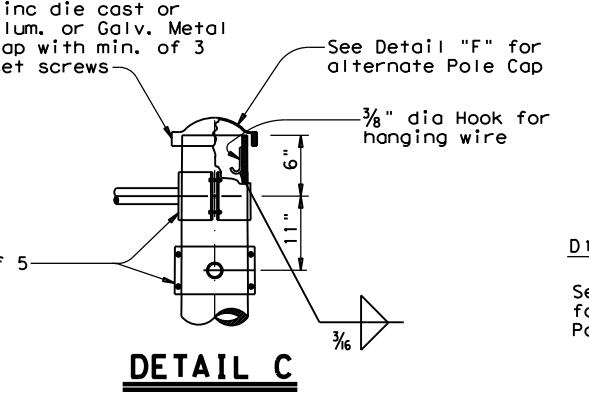

**DETAIL C**

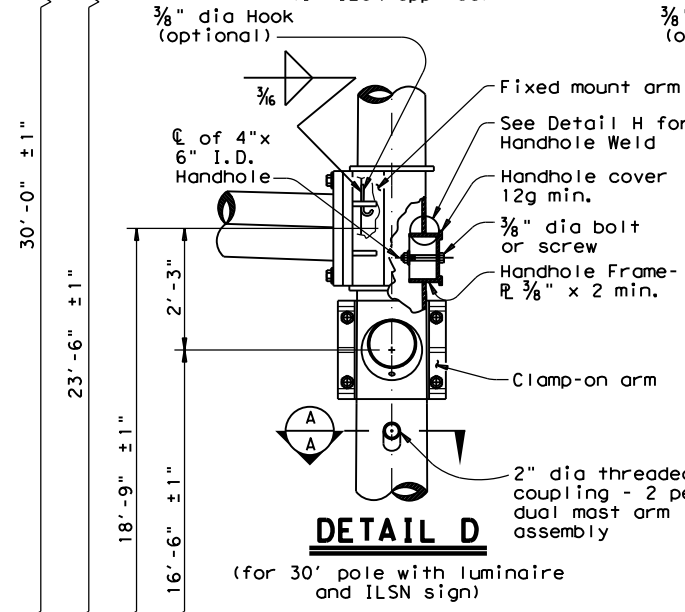

**DETAIL D**  
(for 30' pole with luminaire and ILSN sign)

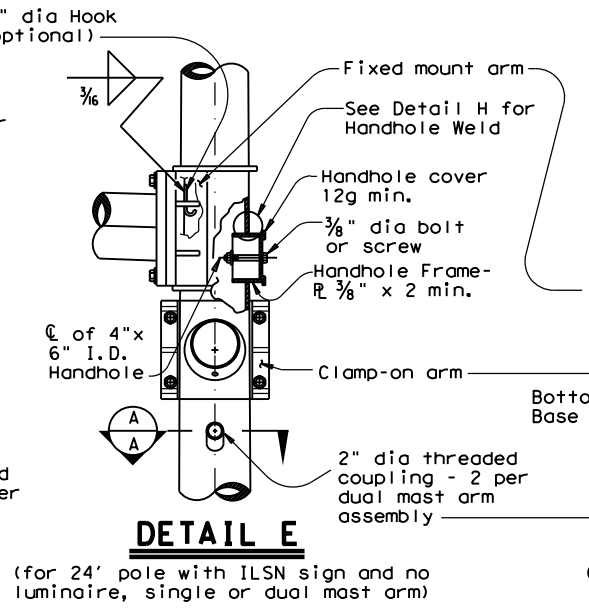

**DETAIL E**  
(for 24' pole with ILSN sign and no luminaire, single or dual mast arm)

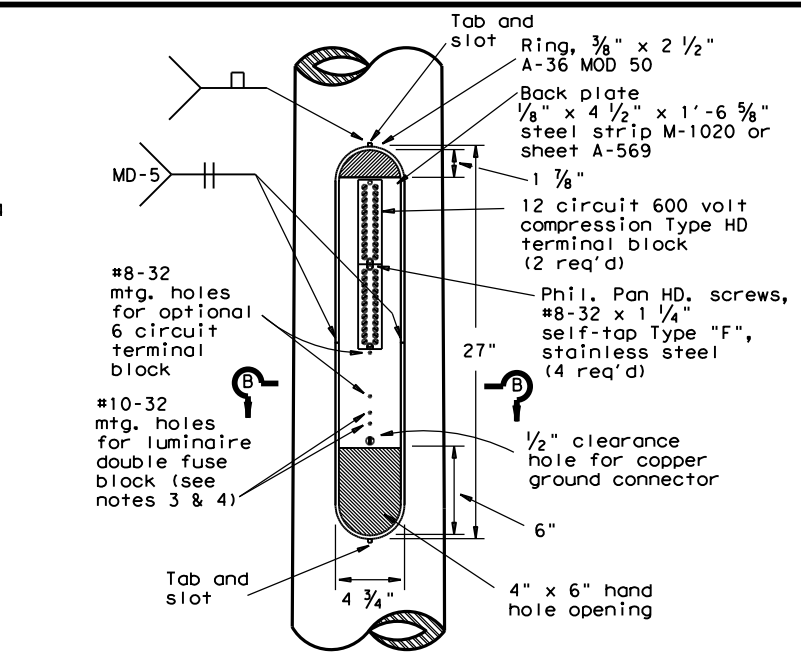

**ACCESS COMPARTMENT**

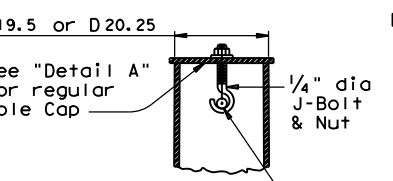

**SECTION Y-Y**

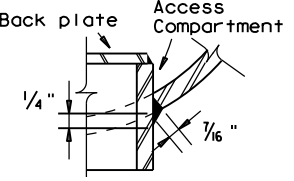

**DETAIL J**

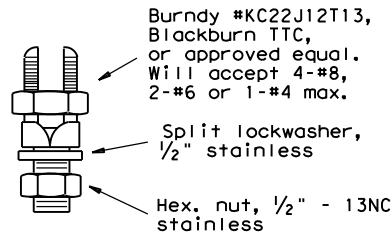

**COPPER GROUND CONNECTOR**

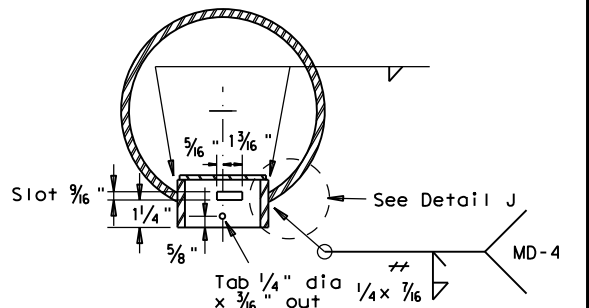

**SECTION B-B**

**ACCESS COMPARTMENT NOTES:**

- The cover shall be one piece formed from ABS plastic, shall be a pearl gray color, and shall be suitable for exposure to harsh sunlight and extreme weather. Cover shall latch with two screw latches and shall fit tightly to the enclosure ring to create a rainproof seal. Latch screws shall be 1/4-20 stainless flat socket head screws with tamper proof feature.
- The pole manufacturer shall provide with each pole a separate kit consisting of: one cover with two latching assemblies, two terminal strips (Marathon #985GP12CU or approved equal), four #8-32 x 1 1/4" self tapping type "F" stainless steel pan head screws, and one ground connector (Blackburn TTC, Burndy KC22J12T13, or Ilco SSS-5). The traffic signal contractor shall install the kit items in the field.
- The screw hole spacing on the enclosure back plate shall be for two Marathon #985GP12 terminal strips, one Marathon #985GP06CU terminal strip, and one Bussmann #BM6032B fuse block.
- Install one Bussmann #BM6032B, Littelfuse #L60030M-2C, or Ferraz-Shawmut #30352 fuse block for poles where luminaires are to be installed.

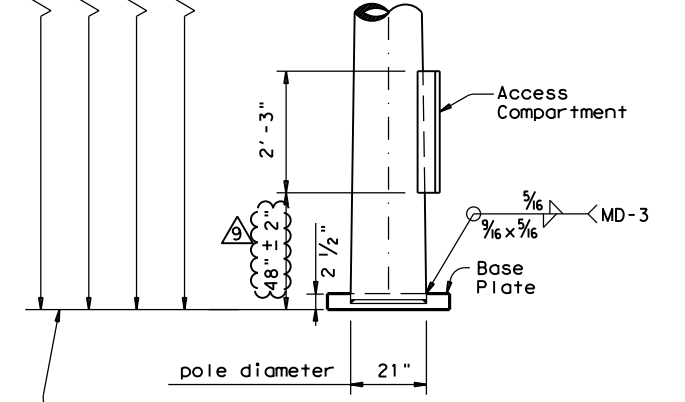

**POLE ELEVATION**

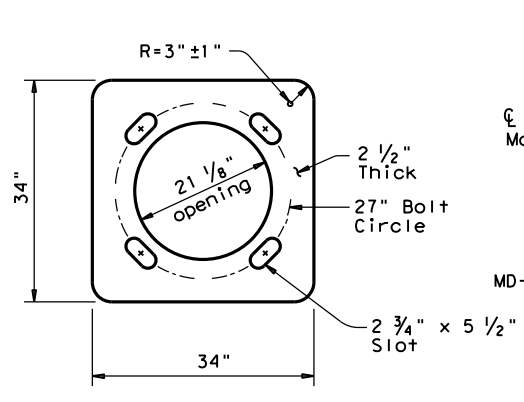

**BASE PLATE**

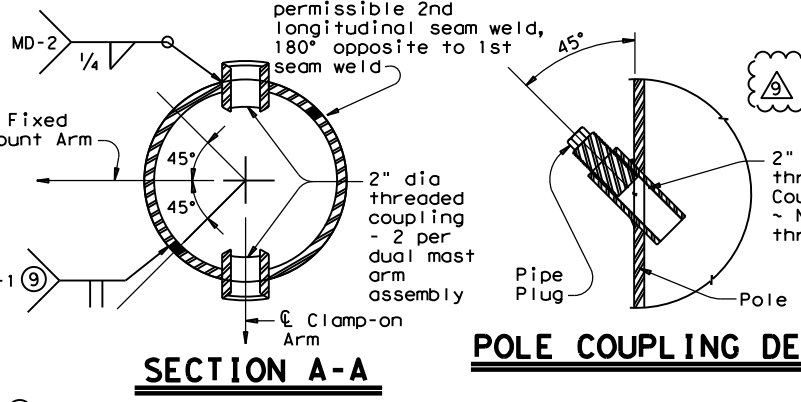

**SECTION A-A**

**POLE COUPLING DETAIL**

⑨ Longitudinal seam weld must be oriented within 90° (45° rotation each side) along the fixed mount arm. 60% min penetration required, 100% penetration within 6" of circumferential base weld.

MATERIALS	
Round Shafts or Polygonal Shafts ⑦	ASTM A595 Gr. A, A588, A1008 HSLAS Gr.50 Class 2, A1011 HSLAS Gr.50 Class 2, A572 Gr.50 or A1011 SS Gr.50 ⑧
Plates ⑦	ASTM A36, A588, or A572 Gr.50
Connection Bolts	ASTM A325, or A449 except where noted
Pin Bolts	ASTM A325
Pipe ⑦	ASTM A53 Gr. B, A501, A1008 HSLAS-F Gr.50, A1011 HSLAS-F Gr.50
Misc. Hardware	Galvanized steel or stainless steel or as noted

- ⑦ ASTM A572, A1008 HSLAS, A1011 HSLAS, A1008 HSLAS-F, A1011 HSLAS-F, or A1011 SS may have higher yield strengths but shall not have less elongation than the grade indicated.
- ⑧ ASTM A1011 SS Gr.50 shall also have a minimum elongation of 18 percent in 8 inches or 23 percent in 2 inches. Material thickness in excess of those stipulated under A1011 SS will be acceptable providing the material meets all other A1011 SS requirements and the requirements of this item.

Texas Department of Transportation

**TRAFFIC SIGNAL SUPPORT STRUCTURES LONG MAST ARM ASSEMBLY (50 TO 65 FT) (80 AND 100 MPH WIND ZONE) LMA(2)-12(DAL)**

Sheet 2 of 5

© TxDOT July 2000		DN: JSY	CK: ARC	DW: TGG	CK: JSY
REVISIONS		CONT	SECT	JOB	HIGHWAY
4-20-01	1-12	091800		392	VA
		DIST	COUNTY	SHEET NO.	
		DAL	DALLAS, ETC.	50	

DISCLAIMER: The use of this standard is governed by the "Texas Engineering Practice Act". No warranty of any kind is made by TxDOT for any purpose whatsoever. TxDOT assumes no responsibility for the conversion of this standard to other formats or for incorrect results or damages resulting from its use.

DATE: 2/14/2024 3:02:28 PM  
 U:\TRAFFIC PROJECTS\0918-00-392 Non-Site 9-24\Microstation Files\049-053 LMA-12\011.dgn

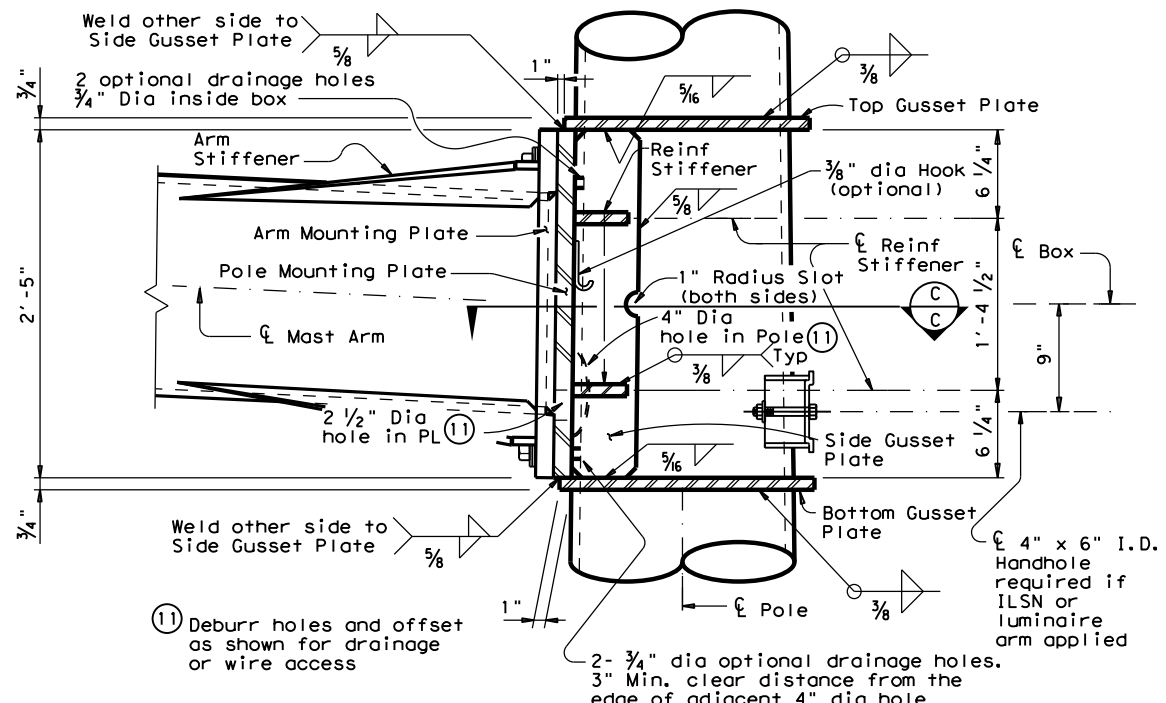

**BUILT-UP BOX CONNECTION**

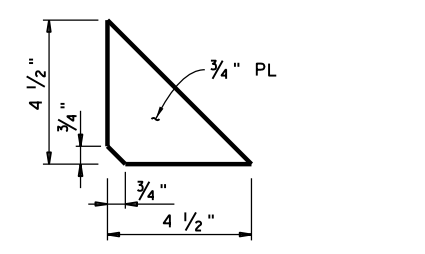

**REINFORCING STIFFENER**

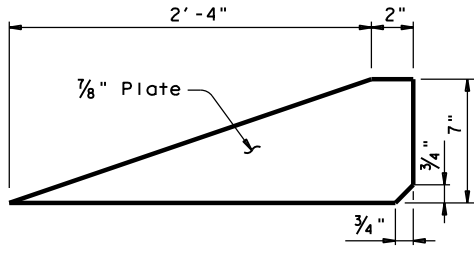

**ARM STIFFENER**  
(Cut to match arm inclination and taper)

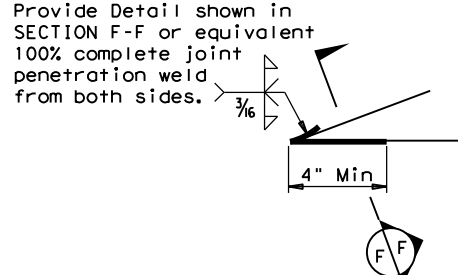

**DETAIL "K"**

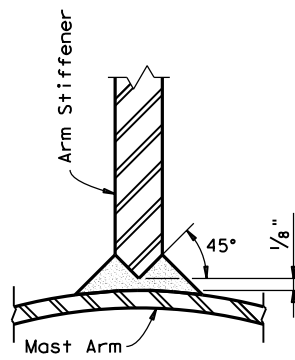

**SECTION F-F**

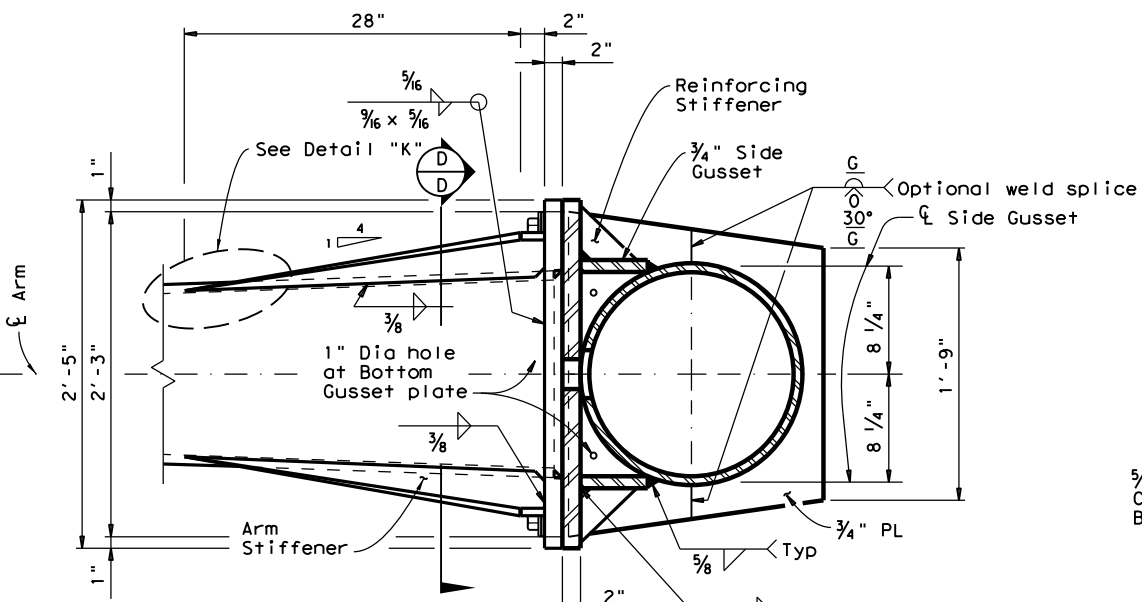

**SECTION C-C**

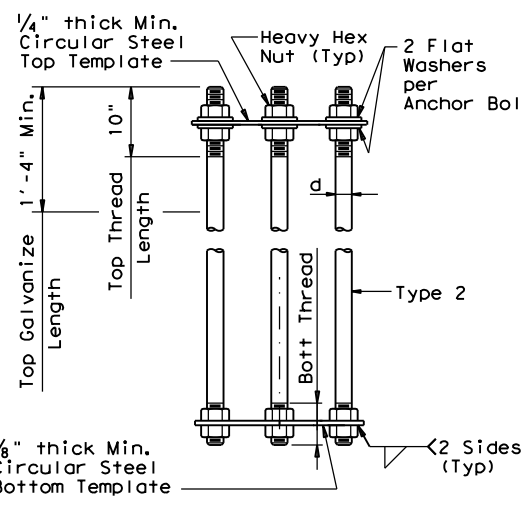

**ANCHOR BOLT ASSEMBLY**

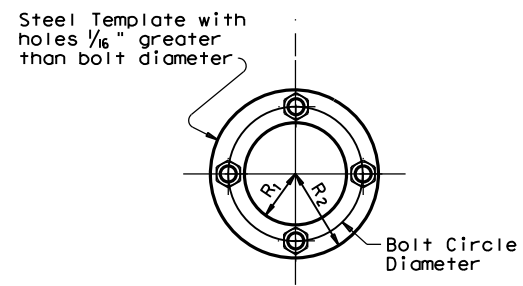

**TEMPLATE DETAIL**

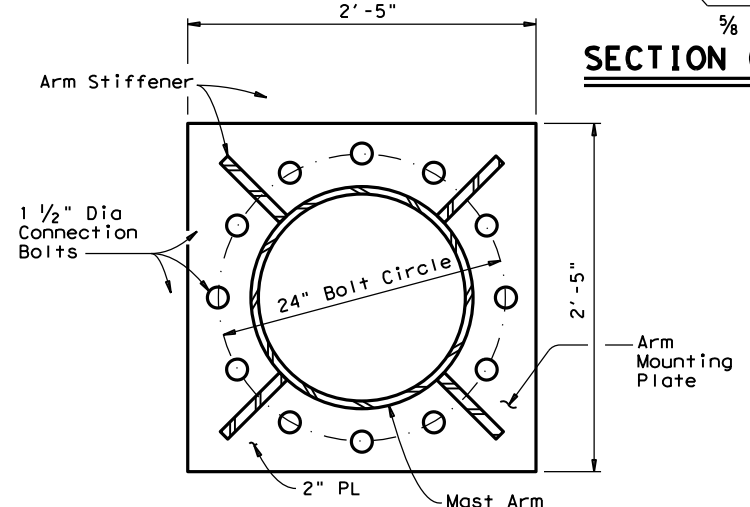

**SECTION D-D**

FDN TYPE	DRILLED SHAFT DIA	REINFORCING STEEL		DRILLED SHAFT LENGTH-ft			ANCHOR BOLT DESIGN			FOUNDATION DESIGN LOAD		TYPICAL APPLICATION	
		VERT BARS	SPIRAL & PITCH	(16), (17), (18)			ANCHOR BOLT DIA	Fy (ksi)	BOLT CIR DIA	ANCHOR TYPE	MOMENT K-ft		SHEAR Kips
				TEXAS CONE PENETROMETER N blows/ft	10	15							
48-A	48"	20 #9	#4 at 6"	21.9	19.5	14.7	2 1/2"	55	27"	2	490	10	50' to 65' Mast arm assembly.

SEE SHEET "TS-FD" FOR ADDITIONAL DETAILS.

- (14) Anchor bolt design develops the foundation capacity given under Foundation Design Loads.
- (15) Foundation Design Loads are the allowable moments and shears at the base of the structure.
- (16) Field Penetrometer readings at a depth of approximately 3 to 5 feet may be used to adjust shaft lengths.
- (17) If rock is encountered, the Drilled Shaft shall extend a minimum of two diameters into solid rock.
- (18) Decimal lengths in Design Table are to allow interpolation for other penetrometer values. Round to nearest foot for entry into Summary Table.

Fixed Mount Arm L F	ROUND POLES (13)					Foundation Type
	D <sub>B</sub>	D <sub>19.5</sub>	D <sub>20.25</sub>	D <sub>24</sub>	D <sub>30</sub>	
ft.	in.	in.	in.	in.	(12)thk in.	
50', 55', 60', 65'	21.0	18.2	17.6	16.8	.3125	48-A

Fixed Mount Arm L F	ROUND ARMS (13)				
	L <sub>1</sub>	D <sub>1</sub>	D <sub>2</sub>	(12)thk in.	Rise
ft.	ft.	in.	in.	in.	
50	49	18.5	11.7	.3125	3'- 3"
55	54	18.5	11.0	.3125	3'- 7"
60	59	18.5	10.3	.3125	3'- 11"
65	64	18.5	9.6	.3125	4'- 4"

- D<sub>B</sub> = Pole Base O.D.
  - D<sub>19.5</sub> = Pole Top O.D. with no Luminaire and no ILSN (single mast arm)
  - D<sub>20.25</sub> = Pole Top O.D. with no Luminaire and no ILSN (dual mast arm)
  - D<sub>24</sub> = Pole Top O.D. with ILSN w/out Luminaire
  - D<sub>30</sub> = Pole Top O.D. with Luminaire
  - D<sub>1</sub> = Arm Base O.D.
  - D<sub>2</sub> = Arm End O.D.
  - L<sub>1</sub> = Shaft Length
  - L F = Fixed Arm Length
- (12) Thickness shown is minimum, thicker materials may be used.
  - (13) Shaft profile 16-sided or 18-sided is considered to be equivalent to round section.

**GENERAL NOTES:**  
 Built-up Box Connection: For the welded arm-to-pole connection as a built-up box configuration illustrated here is an example only, fabricators are required to submit a shop drawing of box connection for approval. The drawing shall specify the details of each box element, welds of arm-to-pole connection, arm-to-plate socket connection, and arm rise creation. Specify the proper location of drain holes along the pole. 2 1/2" dia hole in the pole mounting plate and 4" dia hole in the pole need to be aligned for wiring access or drainage. Arm stiffeners cut to match arm inclination and taper shall also be included.

The deviation from flat for either arm or pole mounting plate shall not exceed 1/32 in., which is measured along the center of mounting plate to a radial distance of 13.5 in. The deformed-from-flat connection between arm and pole mounting plates shall not be allowed if the center of both mounting plates cannot contact directly.

Fixed mount details are used for single mast arm assemblies and for the first arm on dual mast arm assemblies.

ANCHOR BOLT & TEMPLATE SIZE						
Bolt Dia in.	Length #	Top Thread	Bottom Thread	Bolt Circle	R <sub>2</sub>	R <sub>1</sub>
2 1/2"	5'-2"	10"	6 1/2"	27"	16"	11"

\*Min dimension given, longer bolts are acceptable.

**TRAFFIC SIGNAL SUPPORT STRUCTURES**  
**LONG MAST ARM ASSEMBLY**  
**(50 TO 65 FT)**  
**(80 AND 100 MPH WIND ZONE)**  
 Sheet 3 of 5 LMA (3) - 12

© TxDOT July 2000		DN: JSY	CK: ARC	DW: TGG	CK: JSY
REVISIONS		CONT	SECT	JOB	HIGHWAY
4-20-01 1-12		091800		392	VA
DIST		COUNTY		SHEET NO.	
DAL		DALLAS, ETC.		51	

DISCLAIMER: The use of this standard is governed by the "Texas Engineering Practice Act". No warranty of any kind is made by TxDOT for any purpose whatsoever. TxDOT assumes no responsibility for the conversion of this standard to other formats or for incorrect results or damages resulting from its use.

DATE: 2/14/2024 3:02:53 PM  
 U:\TRAFFIC PROJECTS\0918-00-392 Non-Site 9-24\Microstation Files\049-053 LMA-12(Dal).dgn

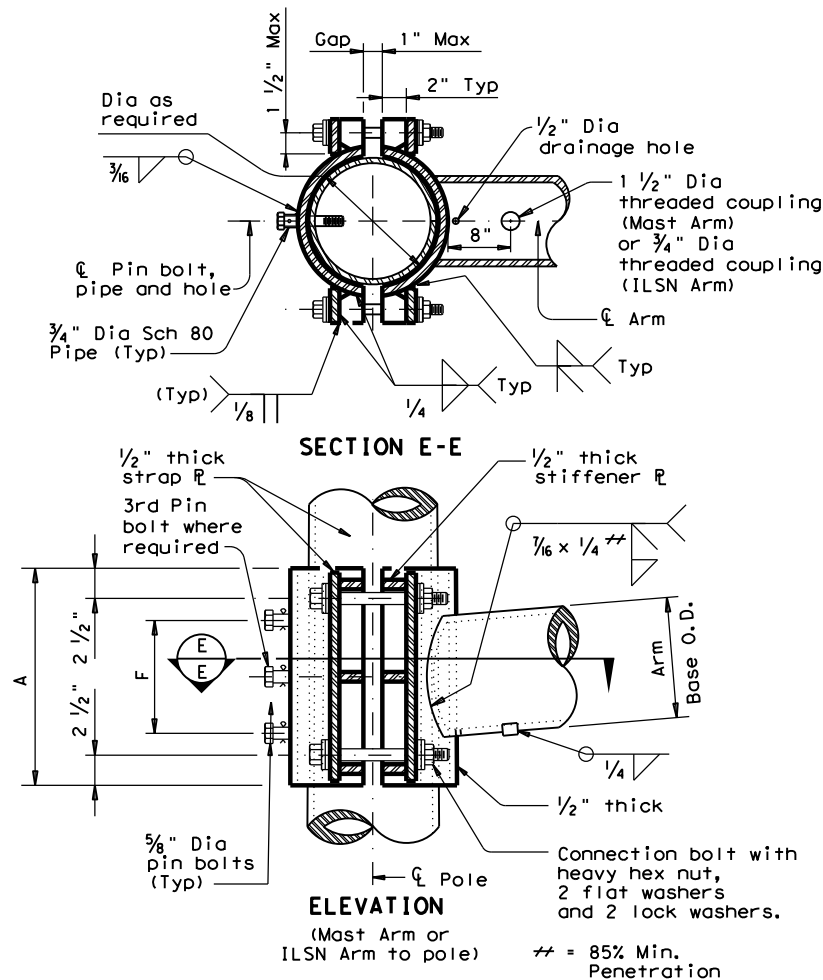

**CLAMP-ON CONNECTION**

80 MPH WIND										
Clamp-on Arm LC	ROUND ARMS					POLYGONAL ARMS				
	L <sub>1</sub>	D <sub>1</sub>	D <sub>2</sub>	thk (12)	Rise	L <sub>1</sub>	D <sub>1</sub>	D <sub>2</sub>	thk (12)	Rise
ft.	ft.	in.	in.	in.		ft.	in.	in.	in.	
20	19.1	6.5	3.8	.179	1'-9"	19.1	7.0	3.5	.179	1'-8"
24	23.1	7.5	4.3	.179	1'-10"	23.1	7.5	3.5	.179	1'-9"
28	27.1	8.0	4.2	.179	1'-11"	27.1	8.0	3.5	.179	1'-10"
32	31.0	9.0	4.7	.179	2'-0"	31.0	9.0	3.5	.179	2'-0"
36	35.0	9.5	4.6	.179	2'-4"	35.0	10.0	3.5	.179	2'-1"
40	39.0	9.5	4.1	.239	2'-8"	39.0	9.5	3.5	.239	2'-3"
44	43.0	10.0	4.1	.239	2'-11"	43.0	10.0	3.5	.239	2'-6"

  

100 MPH WIND										
Clamp-on Arm LC	ROUND ARMS					POLYGONAL ARMS				
	L <sub>1</sub>	D <sub>1</sub>	D <sub>2</sub>	thk (12)	Rise	L <sub>1</sub>	D <sub>1</sub>	D <sub>2</sub>	thk (12)	Rise
ft.	ft.	in.	in.	in.		ft.	in.	in.	in.	
20	19.1	8.0	5.3	.179	1'-8"	19.1	8.0	3.5	.179	1'-7"
24	23.1	9.0	5.8	.179	1'-9"	23.1	9.0	3.5	.179	1'-8"
28	27.1	9.5	5.7	.179	1'-10"	27.1	10.0	3.5	.179	1'-9"
32	31.0	9.5	5.2	.239	1'-11"	31.0	9.5	3.5	.239	1'-10"
36	35.0	10.0	5.1	.239	2'-0"	35.0	10.0	3.5	.239	1'-11"
40	39.0	10.5	5.1	.239	2'-3"	39.0	11.0	3.5	.239	2'-1"
44	43.0	11.0	5.1	.239	2'-8"	43.0	11.5	4.0	.239	2'-3"

D<sub>1</sub> = Arm Base O.D.  
 D<sub>2</sub> = Arm End O.D.  
 L<sub>1</sub> = Shaft Length  
 LC = Clamp-on Arm Length

(12) Thickness shown is minimum, thicker materials may be used.

**ARM COUPLING DETAIL**

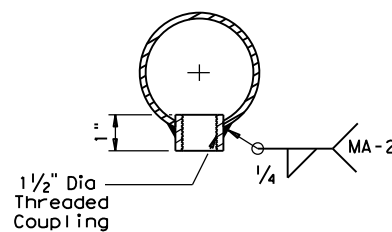

**ILSN ARM COUPLING DETAIL**

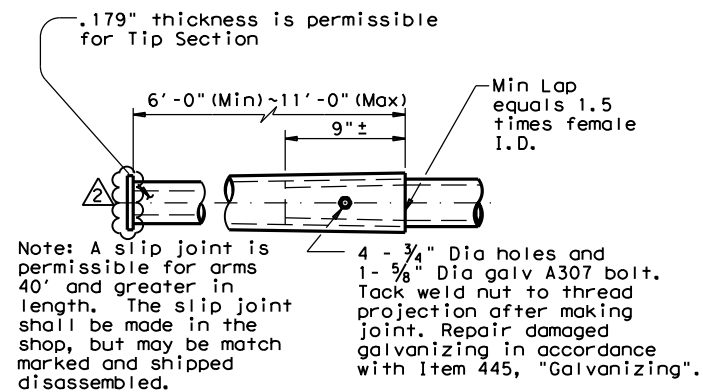
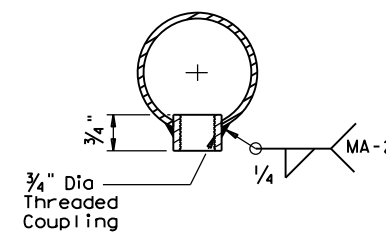

**SLIP JOINT DETAIL (CLAMP-ON ARM)**

Stainless steel bands (or Cables) and cast bracket as in "Astro-Brac", "Sky Bracket" or "Easy Bracket" with 1 1/2" Dia Threaded Coupling.

**BRACKET ASSEMBLY**

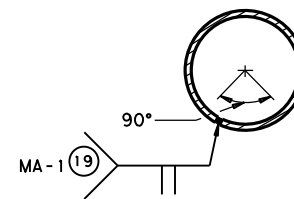

**ARM WELD DETAIL**

(19) Longitudinal Seam Weld must be oriented within the lower 90° of the signal arm. 60% Min penetration 100% penetration within 6" of circumferential base welds.

**CLAMP-ON ARM CONNECTION**

ILSN Arm Size		A	F	4 Conn. Bolts	5/8" Dia. Pin Bolts
Sch 40 pipe Dia	Thick				
in.	in.	in.	in.	in.	ea
3	.216	10	4	3/4	2

Mast Arm Size		A	F	4 Conn. Bolts	5/8" Dia. Pin Bolts
Base Dia	Thick				
in.	in.	in.	in.	in.	ea
6.5	.179	12	6	1	2
7.5	.179	14	8	1	2
8.0	.179	14	8	1	2
9.0	.179	16	10	1	2
9.5	.179	18	12	1 1/4	3
9.5	.239	18	12	1 1/4	3
10.0	.239	18	12	1 1/4	3
10.5	.239	18	12	1 1/4	3
11.0	.239	18	12	1 1/4	3
11.5	.239	18	12	1 1/4	3

**GENERAL NOTES:**

Clamp-on details are used for the second arm on dual mast arm assemblies or ILSN arm support. For a clamp-on mast arm, a maximum 1 1/2" wide vertical slotted hole may be cut in the front clamp plate to facilitate drainage during galvanizing. The slot shall be centered behind the arm and shall be no longer than the arm diameter minus 1". For an ILSN arm, a 1 1/2" diameter hole shall be cut in the front clamp plate for wire access. A matched hole shall be field drilled through the pole to provide wire access after arm is oriented. Deburr both holes.

Where duplicate parts occur on a detail, welds shown for part shall apply to all similar parts on the detail.

Pin bolts are required to prevent rotation of clamp-on arms under design wind forces. Pin bolts shall be ASTM A325 with threads excluded from the shear plane. Pin bolt and 3/4" diameter pipe shall have 3/16" diameter holes for a 1/8" diameter galvanized cotter pin. Back clamp plate shall be furnished with a 3/4" diameter hole for each pin bolt. An 1/16" diameter hole for each pin bolt shall be field drilled through the pole after arm orientations have been approved by the Engineer.

REPLACED TENON DETAIL WITH PLATE WELD DETAIL (2/12).

Texas Department of Transportation

**TRAFFIC SIGNAL SUPPORT STRUCTURES LONG MAST ARM ASSEMBLY (50 TO 65 FT) (80 AND 100 MPH WIND ZONE)**  
 Sheet 4 of 5 LMA(4)-12(DAL)

© TxDOT November 2000		DN: JK	CK: GRB	DW: FDN	CK: CAL
4-20-01	REVISIONS	CONT	SECT	JOB	HIGHWAY
1-12		091800		392	VA
		DIST	COUNTY		SHEET NO.
		DAL	DALLAS, ETC.		52

DISCLAIMER: The use of this standard is governed by the "Texas Engineering Practice Act". No warranty of any kind is made by TxDOT for any purpose whatsoever. TxDOT assumes no responsibility for the conversion of this standard to other formats or for incorrect results or damages resulting from its use.

DATE: 2/14/2024 3:03:14 PM  
U:\TRAFFIC PROJECTS\0918-00-392 Non-Site 9-2A\Microstation Files\049-03 LMA-12(Dal).dgn

Shipping Parts List							
Ship each pole with the following attached: enlarged hand hole, pole cap, fixed arm connection bolts and washers, and any additional hardware listed in the table.							
Nominal Arm Length	30' Poles with Luminaire		24' Poles with ILSN		19.50' (Single Mast Arm) 20.25' (Dual Mast Arm)		Poles with no Luminaire and no ILSN See note above
	See note above plus: one (or two if ILSN attached) small hand hole, clamp-on simplex		See note above plus one small hand hole				
Single Mast Arm							
Lf ft.	Designation	Quantity	Designation	Quantity	Designation	Quantity	
50	50L		50S		50		
55	55L		55S		55		
60	60L		60S		60		
65	65L		65S		65		
Dual Mast Arm							
Lf ft.	Lc ft.	Designation	Quantity	Designation	Quantity	Designation	Quantity
50	20	5020L		5020S		5020	
	24	5024L		5024S		5024	
	28	5028L		5028S		5028	
	32	5032L		5032S		5032	
	36	5036L		5036S		5036	
	40	5040L		5040S		5040	
55	20	5520L		5520S		5520	
	24	5524L		5524S		5524	
	28	5528L		5528S		5528	
	32	5532L		5532S		5532	
	36	5536L		5536S		5536	
	40	5540L		5540S		5540	
60	20	6020L		6020S		6020	
	24	6024L		6024S		6024	
	28	6028L		6028S		6028	
	32	6032L		6032S		6032	
	36	6036L		6036S		6036	
	40	6040L		6040S		6040	
65	20	6520L		6520S		6520	
	24	6524L		6524S		6524	
	28	6528L		6528S		6528	
	32	6532L		6532S		6532	
	36	6536L		6536S		6536	
	40	6540L		6540S		6540	
	44	6544L		6544S		6544	

Foundation Summary Table \*\*

Location Ident.	Avg. N Blow/ft.	No. Each	Drill Shaft *** Length (feet)
			48-A
<b>Total Drill Shaft Length</b>			

Notes

- \*\* Foundations may be listed separately or grouped according to similarity of location and type. Quantities are for the Contractor's information only.
- \*\*\* Decimal lengths in Design Table are to allow interpolation for other penetrometer values. Round to nearest foot for entry into Summary Table.

Abbreviations  
Lf= Fixed Arm Length  
Lc= Clamp-on Arm Length (44' Max.)

REPLACED CGB CONNECTOR WITH BRACKET ASSEMBLY (2/12).

Shipping Parts List								
Traffic Signal Arms (Fixed Mount) (1 per pole) Ship each arm with listed equipment attached								
Nominal Arm Length	Type IV Arm (4 Signals)			Luminaire Arms (1 per 30' pole)				
	4 Bracket Assemblies			Nominal Arm Length		Quantity		
ft.	Designation	Quantity	8' Arm					
50	50IV		ILSN Arm (Max. 2 per pole) Ship with clamps, bolts and washers					
55	55IV		Nominal Arm Length		Quantity			
60	60IV		7' Arm					
65	65IV		9' Arm					
Traffic Signal Arms (80 MPH Clamp-On Mount) (1 per pole) Ship each arm with listed equipment attached								
Nominal Arm Length	Type I Arm (1 Signal)		Type II Arm (2 Signals)		Type III Arm (3 Signals)			
	1 Bracket Assembly and 1 clamp w/bolts and washers		2 Bracket Assemblies and 1 clamp w/bolts and washers		3 Bracket Assemblies and 1 clamp w/bolts and washers			
ft.	Designation	Quantity	Designation	Quantity	Designation	Quantity		
20	20I-80							
24	24I-80		24II-80					
28	28I-80		28II-80					
32			32II-80		32III-80			
36			36II-80		36III-80			
40					40III-80			
44					44III-80			
Traffic Signal Arms (100 MPH Clamp-On Mount) (1 per pole) Ship each arm with listed equipment attached								
Nominal Arm	Type I Arm (1 Signal)		Type II Arm (2 Signals)		Type III Arm (3 Signals)			
	1 Bracket Assembly and 1 clamp w/bolts and washers		2 Bracket Assemblies and 1 clamp w/bolts and washers		3 Bracket Assemblies and 1 clamp w/bolts and washers			
ft.	Designation	Quantity	Designation	Quantity	Designation	Quantity		
20	20I-100							
24	24I-100		24II-100					
28	28I-100		28II-100					
32			32II-100		32III-100			
36			36II-100		36III-100			
40					40III-100			
44					44III-100			
Anchor Bolt Assemblies (1 per pole) Each anchor bolt assembly consists of the following: Top and bottom templates, 4 anchor bolts, 8 nuts, 8 flat washers and 4 nut anchor devices (type 2) per Standard Drawing "IS-FD". Templates may be removed for shipment.								
Anchor Bolt Diameter	Anchor Bolt Length	Quantity						
2 1/2 "	5' - 3"							



**LONG MAST  
ARM ASSEMBLY  
PARTS LIST  
LMA (5) - 12 (DAL)**

Sheet 5 of 5		© TxDOT November 2000		DN: JK	CK: GRB	DW: FDN	CK: CAL
REVISIONS		CONT	SECT	JOB		HIGHWAY	
4-20-01 1-12		091800		392		VA	
		DIST	COUNTY			SHEET NO.	
		DAL	DALLAS, ETC.			53	

DISCLAIMER: The use of this standard is governed by the "Texas Engineering Practice Act". No warranty of any kind is made by TxDOT for any purpose whatsoever. TxDOT assumes no responsibility for the conversion of this standard to other formats or for incorrect results or damages resulting from its use.

DATE: FILE:

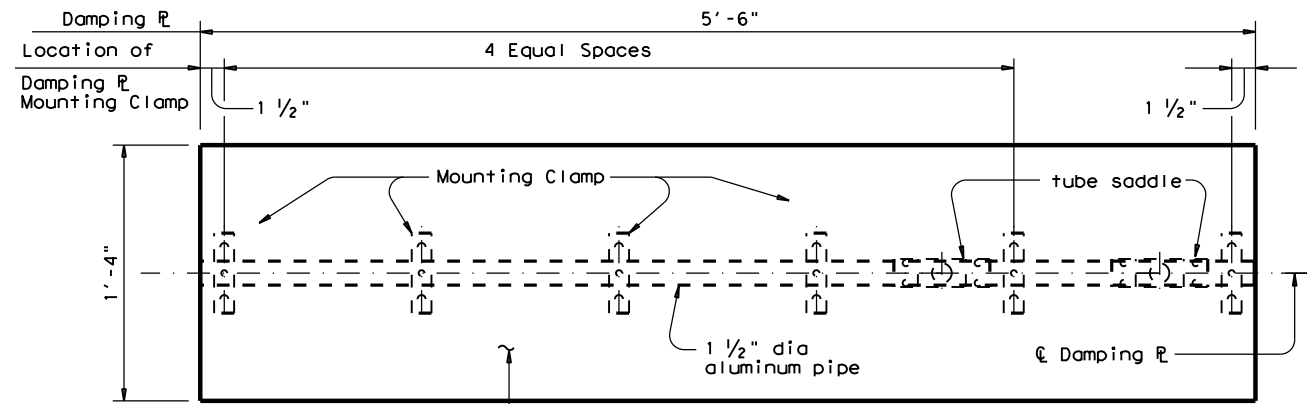

PLAN

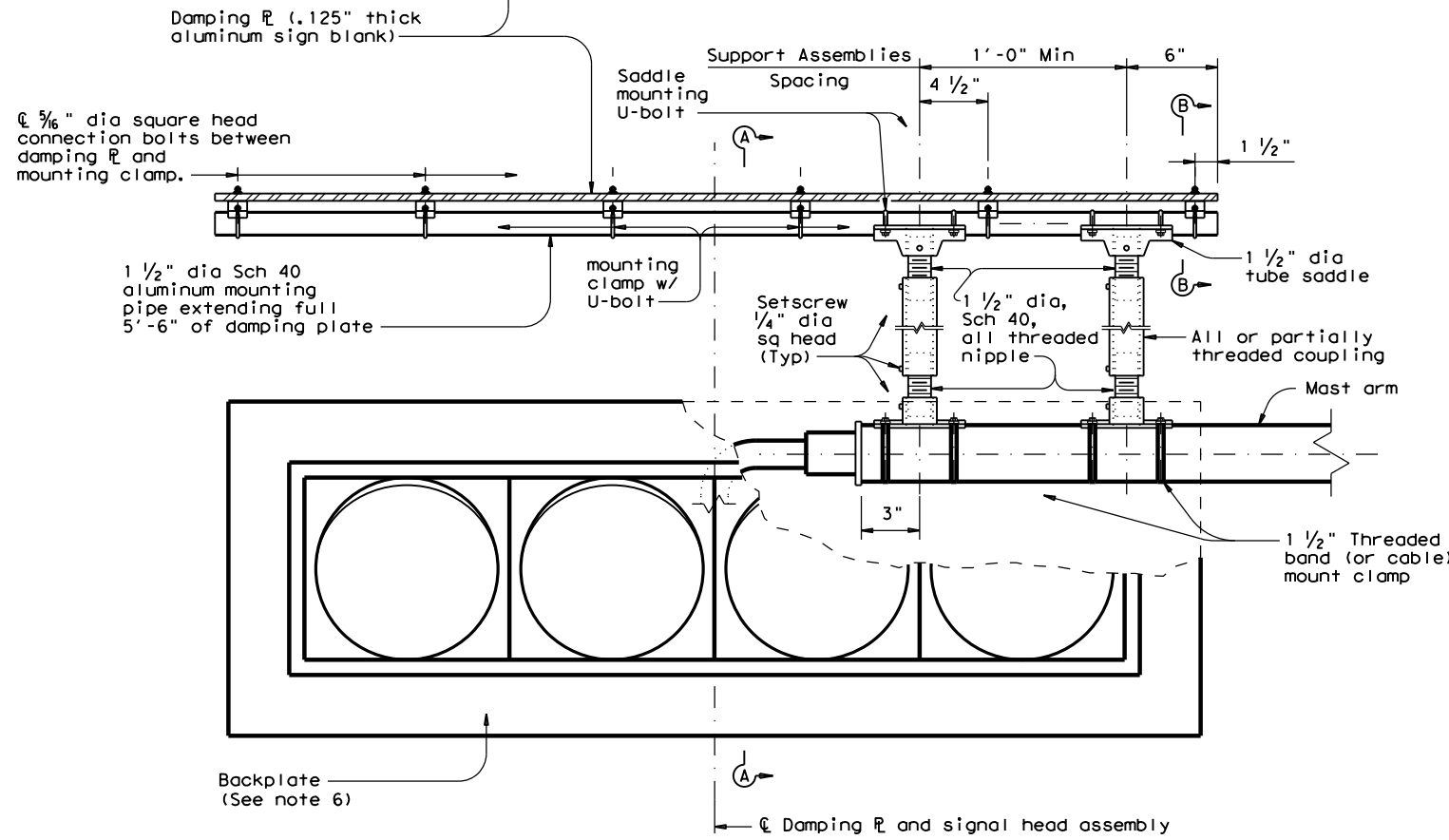

ELEVATION

**DAMPING PLATE MOUNTING DETAILS**

(Showing alternate placement of signal head)

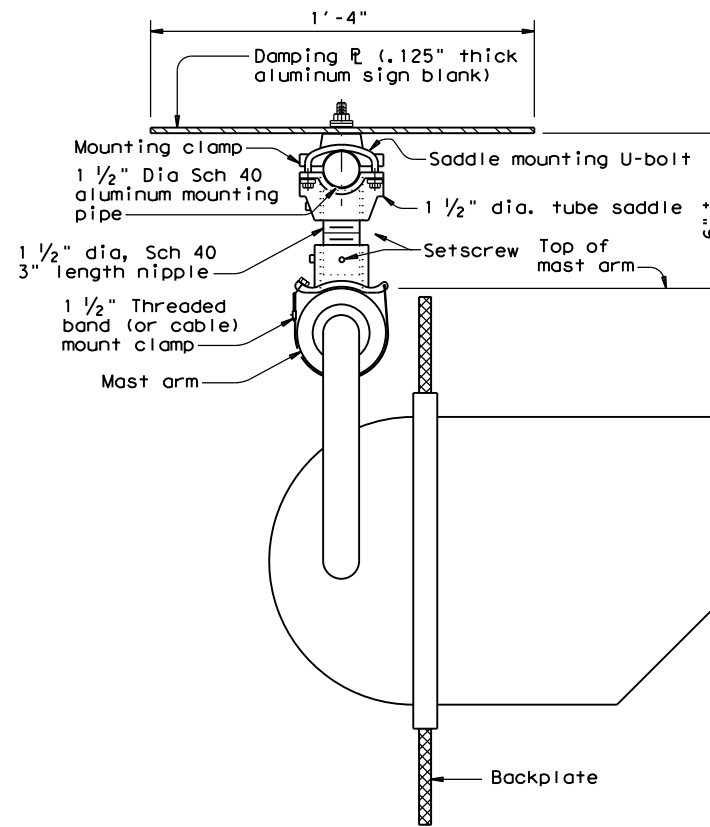

SECTION A-A

(Showing standard placement of signal head)  
(Mounting clamp U-bolt is not shown for clarity)

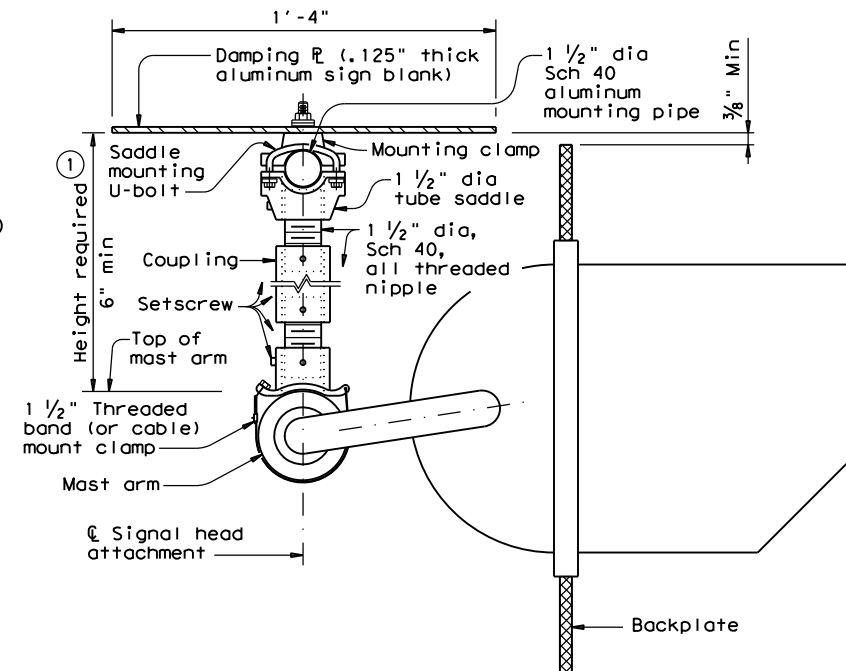

SECTION A-A

(Showing alternate placement of signal head)  
(Mounting clamp U-bolt is not shown for clarity)

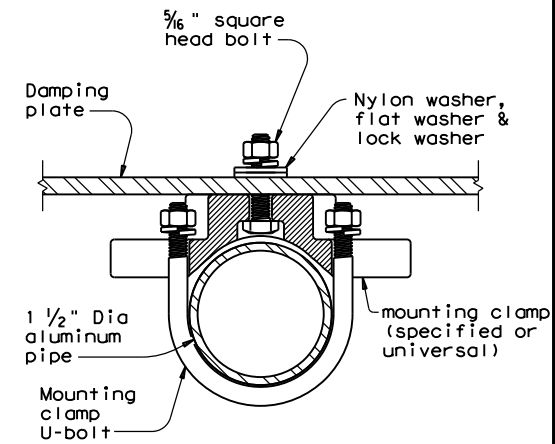

SECTION B-B

(Showing damping plate attachment)

**GENERAL NOTES:**

- In accordance with the findings of TxDOT sponsored research, the installation of a damping plate in accordance with the details shown here at the end of signal mast arms of SMA and DMA standard structures reduces excessive harmonic vertical vibration, and thus fatigue damage. Any deviation from these details may reduce the effectiveness of this damping device.
- Aluminum sign blank for damping plate will conform to Departmental Material Specifications DMS-7110. Materials for mast arm mounting clamp and tube saddle will be aluminum castings or aluminum alloys as in accordance with manufacturers' stipulations. Mounting pipe, pipe nipple and coupling will be aluminum alloy 6061-T6 or 6063-T6. Damping plate mounting clamp and u-bolt assemblies will conform to Standard sheet SMD(GEN). U-bolts for saddle mounting will have a minimum yield strength of 36 ksi.
- Damping plate will be mounted horizontally. Position centerline of damping plate to align with centerline of mast arm or horizontal signal head assembly. Vertical clearance between signal head (with or without backing plate) and bottom of damping plate will be maintained as shown. The attachments shown here are examples only, other supporting details which meet both alignment and vertical clearance requirements are also acceptable.
- Unless stipulated by the manufacturers, all steel parts will be galvanized finish in accordance with Standard Specification Item 445, "Galvanizing".
- Contractor will verify applicable field dimensions before the installation.
- Backplates are optional for traffic signals. When backplates are used, Backplates will have a 2-inch fluorescent yellow AASHTO Type BFL or CFL retroreflective border conforming to TxDOT DMS-8300 "Sign Face Materials." See Sheet TS-BP-20 for backplate details.

Texas Department of Transportation  
Traffic Safety Division Standard

**MAST ARM DAMPING PLATE DETAILS**

**MA-DPD-20**

FILE: ma-dpd-20.dgn    DN: TxDOT    CK: TxDOT    DW: TxDOT    CR: TxDOT

© TxDOT June 2020    REVISIONS    CONT    SECT    JOB    HIGHWAY

4-20    0918    00    392    VA

6-20    DIST    COUNTY    SHEET NO.

DAL    DALLAS, ETC.    54

① Recommended supporting assemblies to achieve required height for horizontal section heads

Height required	One nipple each length	Two nipples each length plus One coupling each length	
6"-6 3/4"	3"	-	-
7"-8 1/2"	4"	-	-
9"-10 1/2"	6"	-	-
11"-15 1/2"	-	4"	5"
16"-24"	-	6"	10"

DISCLAIMER: The use of this standard is governed by the "Texas Engineering Practice Act". No warranty of any kind is made by TxDOT for any purpose whatsoever. TxDOT assumes no responsibility for the conversion of this standard to other formats or for incorrect results or damages resulting from its use.

DATE:  
FILE:

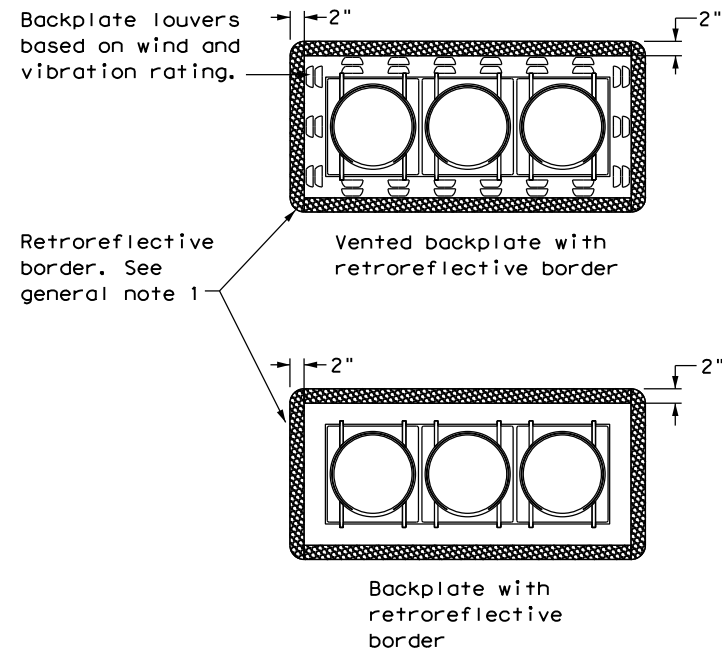

**THREE-SECTION HEAD**  
HORIZONTAL OR VERTICAL

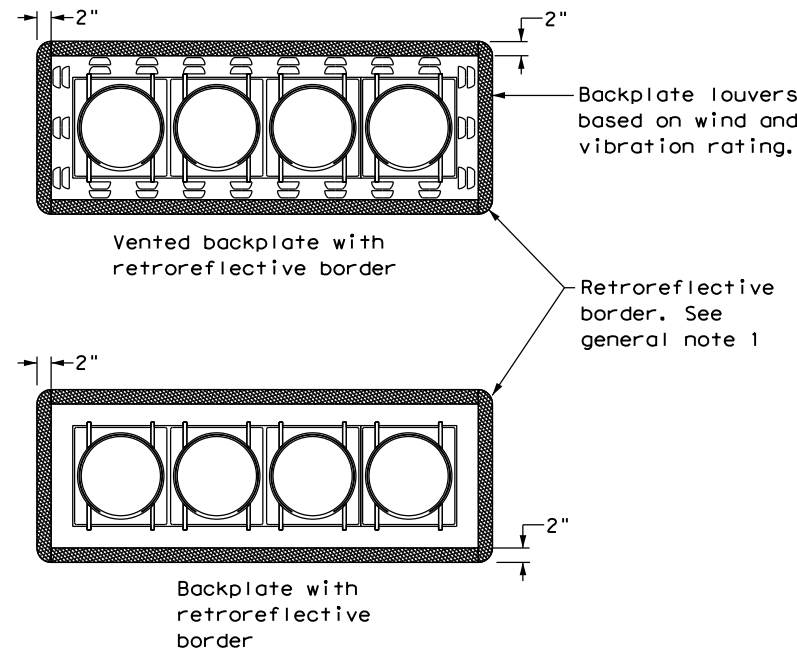

**FOUR-SECTION HEAD**  
HORIZONTAL OR VERTICAL

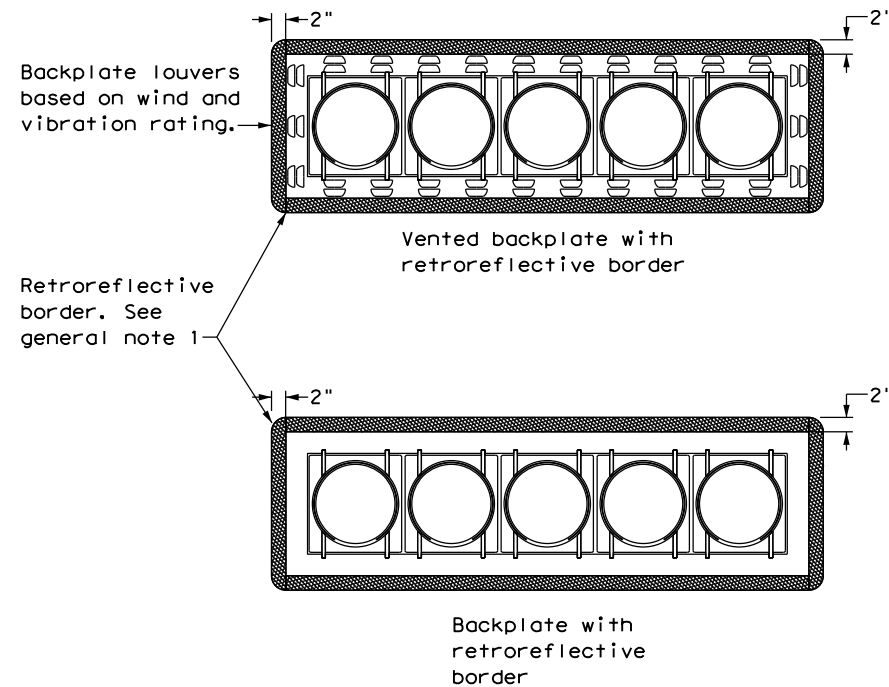

**FIVE-SECTION HEAD**  
HORIZONTAL OR VERTICAL

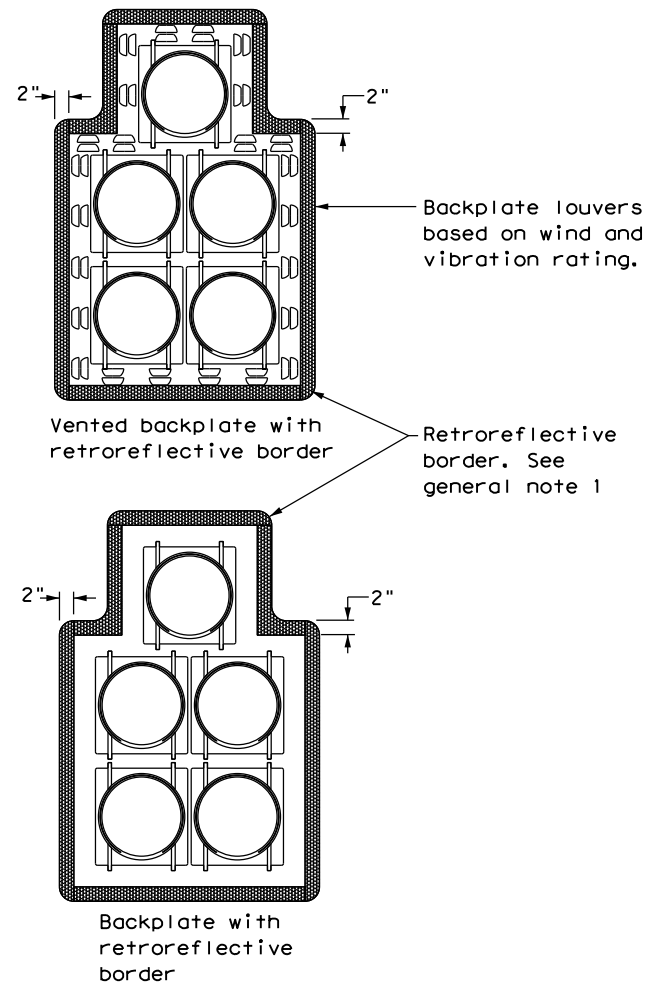

**FIVE-SECTION HEAD**  
CLUSTER

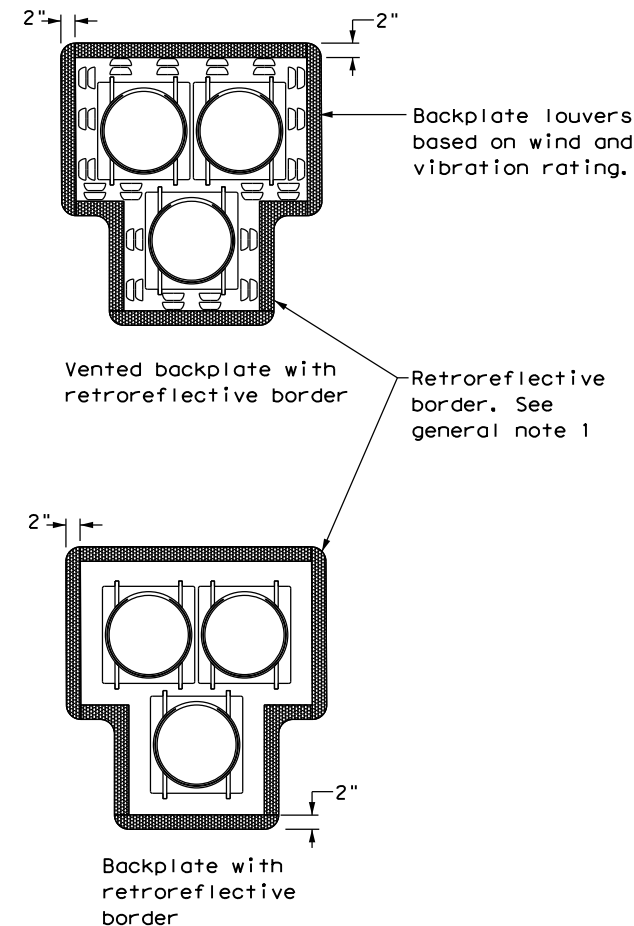

**PEDESTRIAN HYBRID**  
BEACON

**GENERAL NOTES:**

1. Backplates are optional for traffic signals and pedestrian hybrid beacons. When backplates are used, a 2-inch wide fluorescent yellow AASHTO Type B<sub>FL</sub> or C<sub>FL</sub> retroreflective border conforming to TxDOT DMS-8300 is required. Place on all approaches when used.
2. Signal head and backplate compatibility must be verified by the contractor prior to installation.
3. When using backplates on signal heads, venting is preferred to reduce cyclic vibration stress.
4. When a vented backplate is used, the retroreflective border must not be placed over the louvers.
5. This standard sheet applies to all signal heads with backplates, including but not limited to:
  - Pole mounted
  - Overhead mounted
  - Span wire mounted
  - Mast arm mounted
  - Vertical signal heads
  - Horizontal signal heads
  - Clustered signal heads
  - Pedestrian hybrid beacons

		Traffic Safety Division Standard	
<b>TRAFFIC SIGNAL HEAD WITH BACKPLATE</b> <b>TS-BP-20</b>			
FILE: ts-bp-20.dgn	DN: TxDOT	CK: TxDOT	DW: TxDOT
© TxDOT June 2020	CONT: 0918	SECT: 00	JOB: 392
REVISIONS	DIST: DAL		COUNTY: DALLAS, ETC.
	SHEET NO.		55

DISCLAIMER: The use of this standard is governed by the "Texas Engineering Practice Act". No warranty of any kind is made by TxDOT for any purpose whatsoever. TxDOT assumes no responsibility for incorrect results or damages resulting from its use.

DATE: 2/14/2024 3:05:54 PM  
 U:\TRAFFIC PROJECTS\0918-00-392 Non-Site 9-24\Microstation Files\056 MA-D-12(DAL).dgn

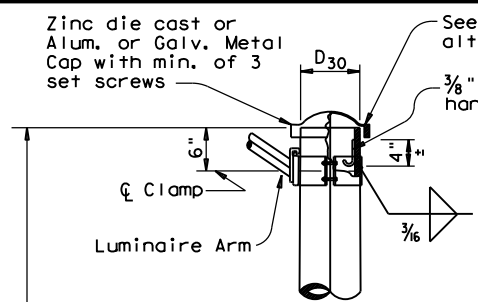

**DETAIL A**

(for pole with luminaire)

**POLE COUPLING DETAIL**

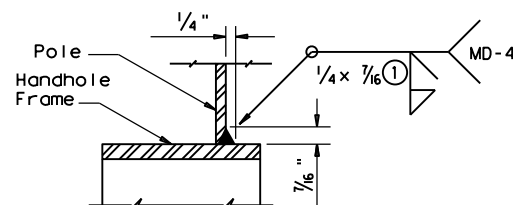
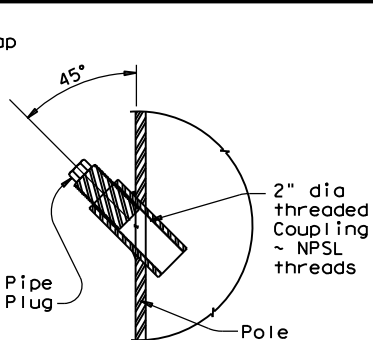

**DETAIL G**

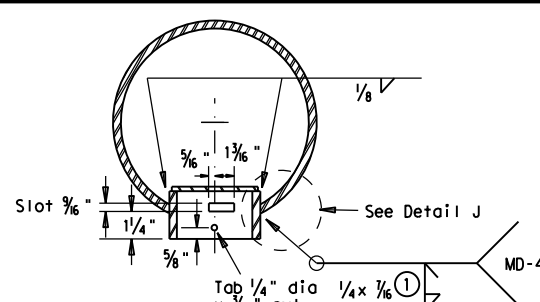

**SECTION X-X**

Opening for access compartment shall be no more than 1/16 inch wider than the access compartment itself.

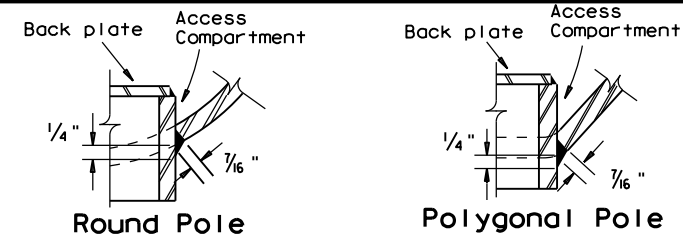

**DETAIL J**

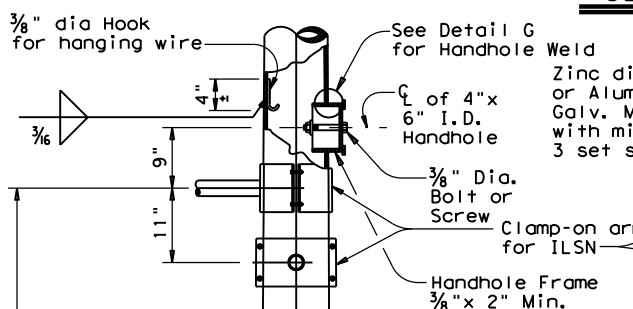

**DETAIL B**

(If ILSN applied)

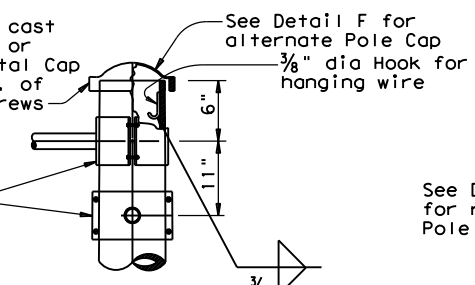

**DETAIL C**

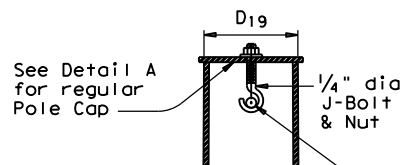

**SECTION Y-Y**

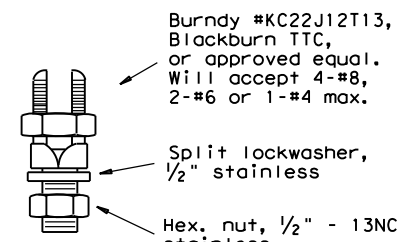

**COPPER GROUND CONNECTOR**

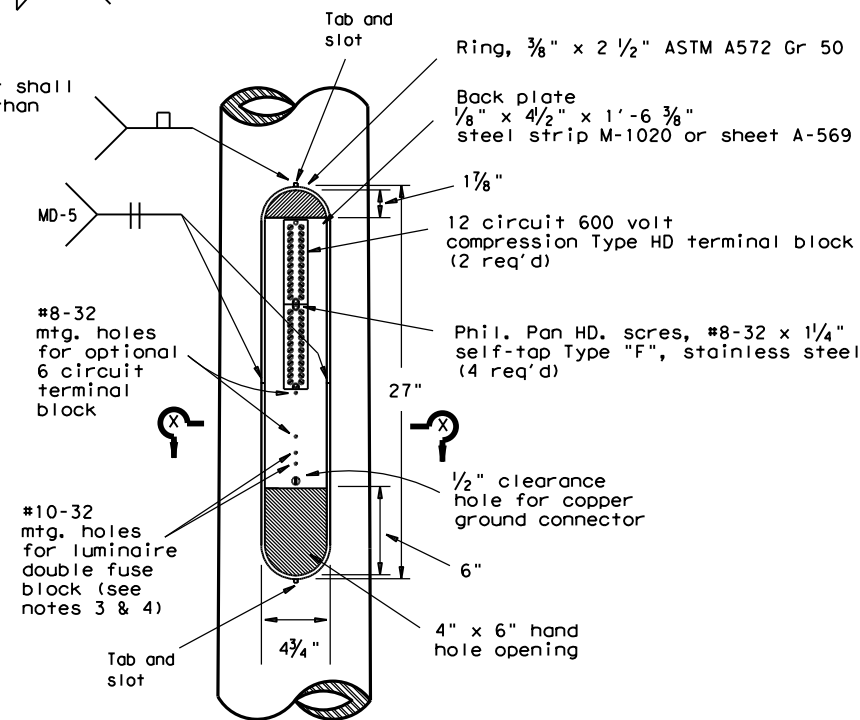

**ACCESS COMPARTMENT**

**NOTES:**

- The cover shall be one piece formed from ABS plastic, shall be a pearl gray color, and shall be suitable for exposure to harsh sunlight and extreme weather. Cover shall latch with two screw latches and shall fit tightly to the enclosure ring to create a rainproof seal. Latch screws shall be 1/4-20 stainless flat socket head screws with tamper proof feature.
- The pole manufacturer shall provide with each pole a separate kit consisting of: one cover with two latching assemblies, two terminal strips (Marathon #985GP12CU or approved equal), four #8-32 x 1 1/4 self tapping type "F" stainless steel pan head screws, and one ground connector (Blackburn TTC, Burndy KC22J12T13, or IlSCO SSS-5). The traffic signal contractor shall install the kit items in the field.
- The screw hole spacing on the enclosure back plate shall be for two Marathon #985GP12 terminal strips, one Marathon #985GP06CU terminal strip, and one Bussmann #BM6032B fuse block.
- Install one Bussmann #BM6032B, Littelfuse #L60030M-2C, or Ferraz-Shawmut #30352 fuse block for poles where luminaires are to be installed.

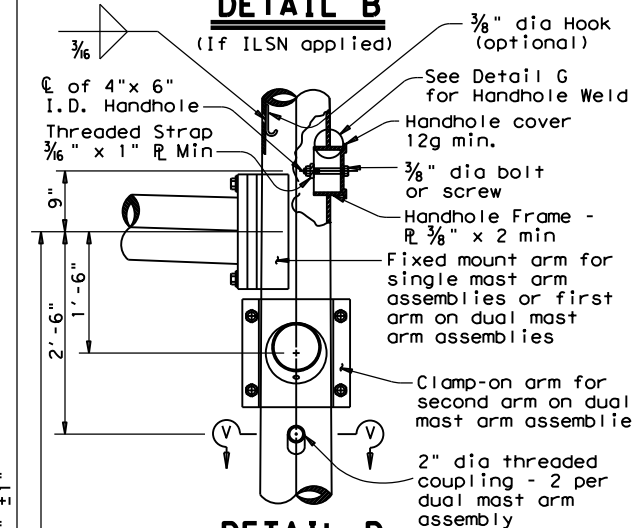

**DETAIL D**

(for 30' pole with luminaire and ILSN sign)

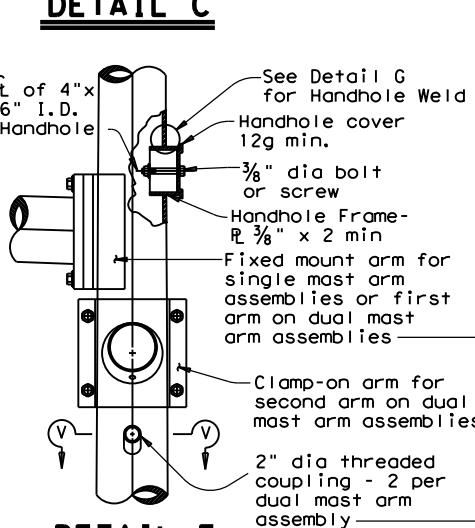

**DETAIL E**

(for 24' pole with ILSN sign and no luminaire)

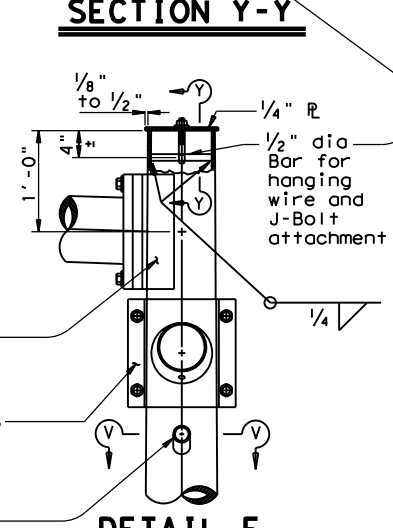

**DETAIL F**

(for 19' pole with no ILSN sign and no luminaire)

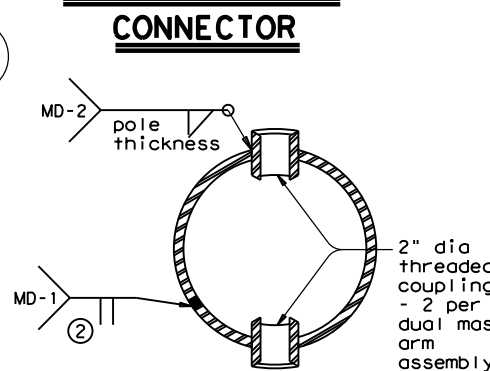

**SECTION V-V**

Anchor Bolt Diameter	Bolt Hole Diameter	Slot Length	Bolt Circle Diameter	Base R Dim. L x T	Adjust. Range
1 1/2"	1 3/4"	3 1/2"	17"	18" x 1 1/2"	13.4°
1 3/4"	2"	4"	19"	20" x 1 3/4"	13.5°
2"	2 1/4"	4 1/2"	21"	22" x 2"	13.6°
2 1/4"	2 1/2"	5"	23"	24" x 2 1/4"	13.7°

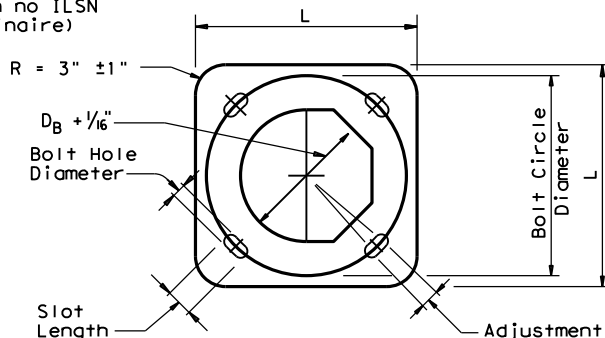

**BASE PLATE PLAN**

- 85% Min. penetration
- 60% Min. penetration  
100% penetration within 6" of circumferential base welds.

REVISOR: REVISED THE ELEVATION OF ACCESS COMPARTMENT (2/12).

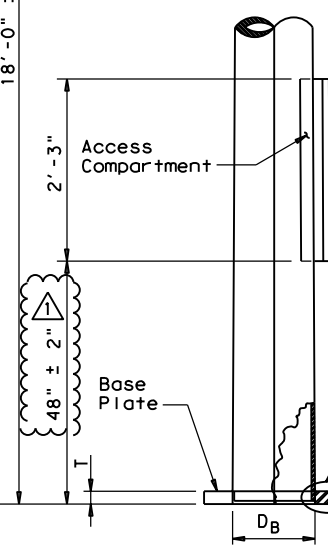

**POLE ELEVATION**

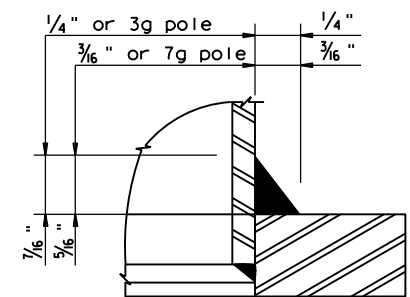

**DETAIL H**

Texas Department of Transportation

**TRAFFIC SIGNAL SUPPORT STRUCTURES MAST ARM POLE DETAILS**

**MA-D-12 (DAL)**

© TxDOT August 1995		DN: MS	CK: JSY	DW: FDN	CK: CAL
REVISIONS					
091800	1-12	CONT	SECT	JOB	HIGHWAY
				392	VA
DIST	COUNTY	SHEET NO.			
DAL	DALLAS, ETC.	56			



DISCLAIMER: The use of this standard is governed by the "Texas Engineering Practice Act". No warranty of any kind is made by TxDOT for any purpose whatsoever. TxDOT assumes no responsibility for the conversion of this standard to other formats or for incorrect results or damages resulting from its use.

DATE: 2/14/2024 3:06:16 PM  
 U:\TRAFFIC PROJECTS\0918-00-392 Non-Site 9-24\Microstation Files\057 MA-C-12.dgn

ARM SIZE		A	B	C	D	E	CONN BOLT DIA
D <sub>1</sub>	ϕ	in.	in.	in.	in.	in.	in.
6.5	.179	12	9	9	6	1 3/4	1
7.5	.179	13	9	10	6	1 3/4	1
8.0	.179	14	10	11	7	2	1 1/4
9.0	.179	16	11	13	8	2	1 1/4
9.5	.179	17	12	14	9	2	1 1/4
9.5	.239	18	12	15	9	2	1 1/4
10.0	.239	18	12	15	9	2	1 1/4
10.5	.239	18	13	15	10	3	1 1/2
11.0	.239	18	13	15	10	3	1 1/2

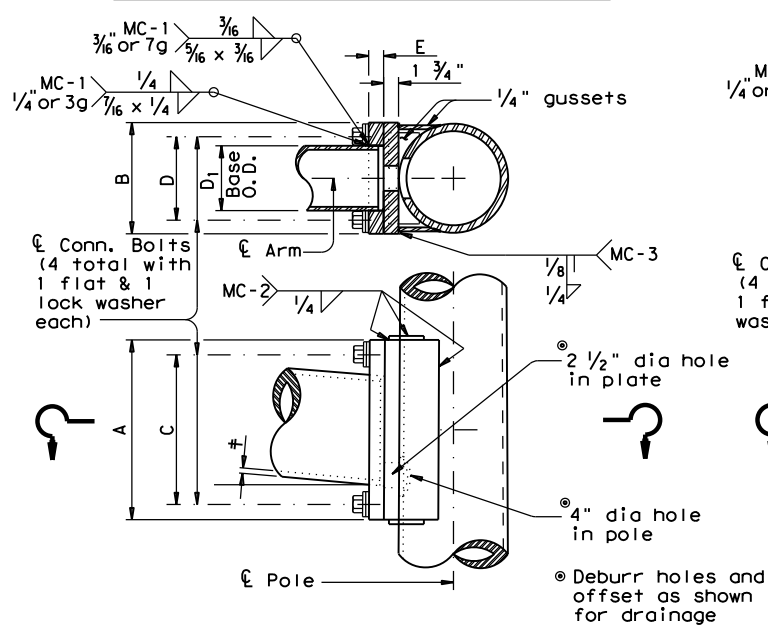

**FIXED MOUNT DETAIL 1**

ARM SIZE		A	F	CONN. BOLTS		PIN BOLTS	
D <sub>1</sub>	ϕ	in.	in.	No.	Dia	No.	Dia
6.5	.179	12	6	4	1	2	5/8
7.5	.179	14	8	4	1	2	5/8
8.0	.179	14	8	4	1	2	5/8
9.0	.179	16	10	4	1	2	5/8
9.5	.179	18	12	4	1 1/4	3	5/8
9.5	.239	18	12	4	1 1/4	3	5/8
10.0	.239	18	12	4	1 1/4	3	5/8

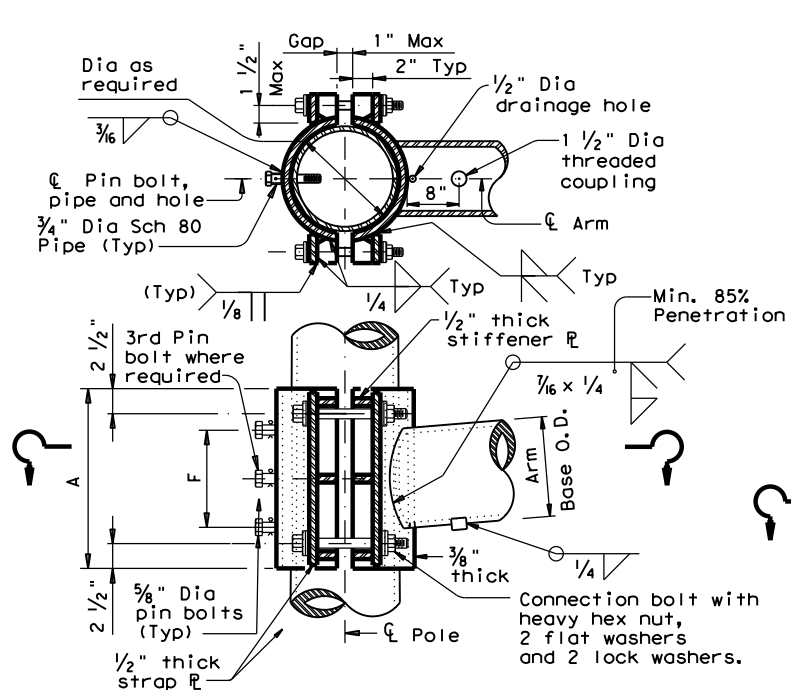

**CLAMP-ON DETAIL 1**

ARM SIZE		A	B	C	D	E	CONN BOLT DIA
D <sub>1</sub>	ϕ	in.	in.	in.	in.	in.	in.
7.0	.179	11	11	8	8	1 3/4	1 1/4
7.5	.179	11	11	8	8	1 3/4	1 1/4
8.0	.179	11	11	8	8	2	1 1/4
9.0	.179	13	13	10	10	2	1 1/4
10.0	.179	13	13	10	10	2	1 1/4
9.5	.239	13	13	10	10	2	1 1/4
10.0	.239	14	14	11	11	2	1 1/2
11.0	.239	14	14	11	11	3	1 1/2
11.5	.239	14	14	11	11	3	1 1/2

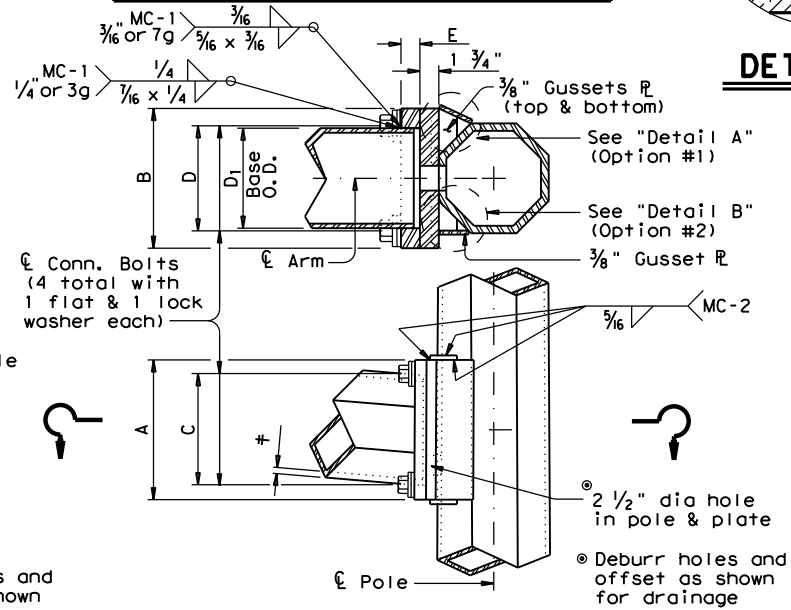

**FIXED MOUNT DETAIL 2**

ARM SIZE		A	F	T	CONN. BOLTS		PIN BOLTS	
D <sub>1</sub>	ϕ	in.	in.	in.	No.	Dia	No.	Dia
7.0	.179	12	6	3/4	4	3/4	2	5/8
7.5	.179	14	8	3/4	4	3/4	2	5/8
8.0	.179	14	8	3/4	4	3/4	2	5/8
9.0	.179	16	10	7/8	4	1	2	5/8
10.0	.179	18	10	7/8	4	1	2	5/8
9.5	.239	18	10	1	6	1	3	5/8
10.0	.239	18	10	1	6	1	3	5/8

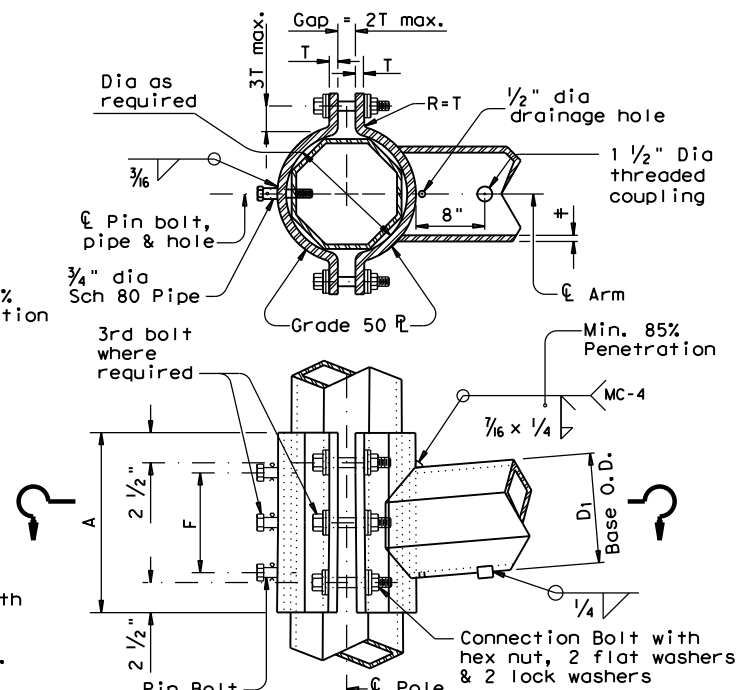

**CLAMP-ON DETAIL 2**

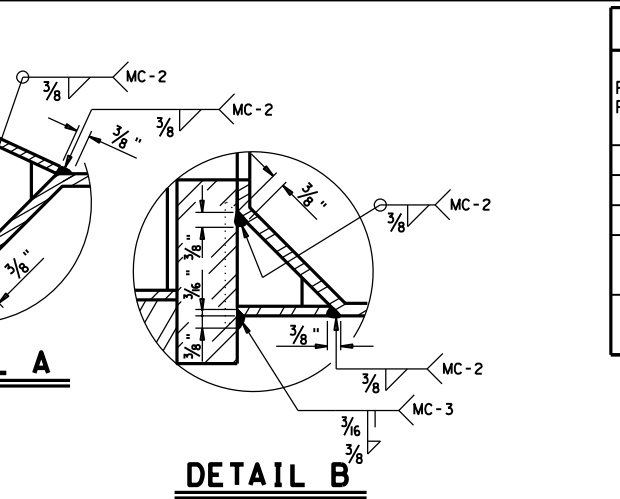

**ARM BASE WELD DETAILS**

ARM SIZE		A	F	CONN. BOLTS		PIN BOLTS	
D <sub>1</sub>	ϕ	in.	in.	No.	Dia	No.	Dia
6.5	.179	12	6	4	1	2	5/8
7.5	.179	14	8	4	1	2	5/8
8.0	.179	14	8	4	1	2	5/8
9.0	.179	16	10	4	1	2	5/8
9.5	.179	18	12	6	1	3	5/8
9.5	.239	18	12	6	1	3	5/8
10.0	.239	18	12	6	1	3	5/8

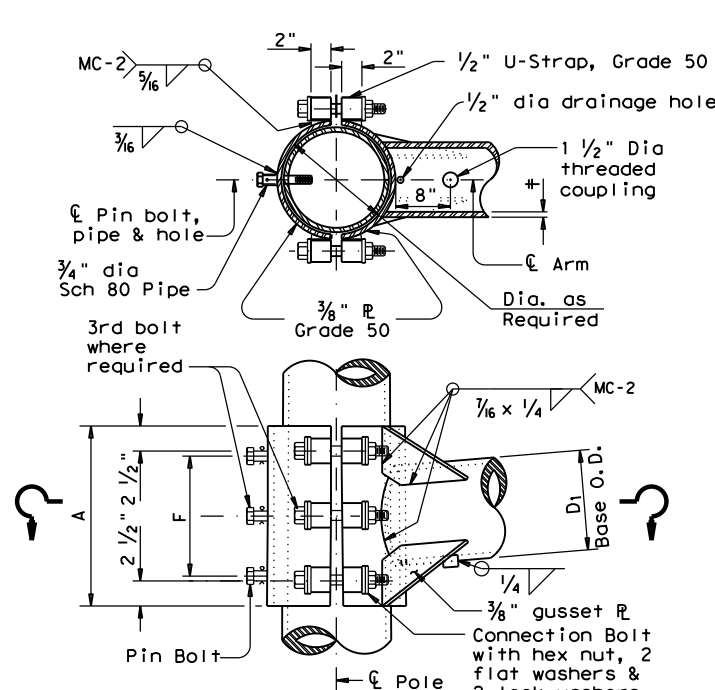

**CLAMP-ON DETAIL 3**

MATERIALS	
Round Shafts or Polygonal Shafts ①	ASTM A595 Gr.A, A588, A1008 HSLAS Gr.50 Class 2, A1011 HSLAS Gr.50 Class 2, A572 Gr.50 or A1011 SS Gr.50 ②
Plates ①	ASTM A36, A588, or A572 Gr.50
Connection Bolts	ASTM A325 or A449, except where noted
Pin Bolts	ASTM A325
Pipe ①	ASTM A53 Gr.B, A501, A1008 HSLAS-F Gr.50, A1011 HSLAS-F Gr.50
Misc. Hardware	Galvanized steel or stainless steel or as noted

- ① ASTM A572, A1008 HSLAS, A1011 HSLAS, A1008 HSLAS-F, A1011 HSLAS-F or A1011 SS may have higher yield strengths but shall not have less elongation than the grade indicated.
- ② ASTM A1011 SS Gr.50 material shall also have a minimum elongation of 18 percent in 8 inches or 23 percent in 2 inches. Material thickness in excess of those stipulated under A1011 SS will be acceptable providing the material meets all other A1011 SS requirements and the requirements of this item.

**GENERAL NOTES:**

Clamp-on details are used for the second arm on dual mast arm assemblies. A Maximum 1 1/2" wide vertical slotted hole shall be cut in the front clamp plate to facilitate drainage during galvanizing. The slot shall be centered behind the arm and shall be no longer than the arm diameter minus 1"

Fixed mount details are used for single mast arm assemblies and for the first arm on dual mast arm assemblies.

Where duplicate parts occur on a detail, welds shown for one part shall apply to all similar parts on the detail.

Pin bolts are required to prevent rotation of clamp-on arms under design wind forces.

**NOTE:**

Pin bolts shall be A325 with threads excluded from the shear plane. Pin bolt and 3/4" dia pipe shall have 3/16" dia holes for a 1/8" dia galvanized cotter pin. Back clamp plate shall be furnished with a 3/4" dia hole for each pin bolt. An 1/16" dia hole for each pin bolt shall be field drilled through the pole after arm orientations have been approved by the Engineer.

**Texas Department of Transportation**  
 Traffic Operations Division

**STANDARD ASSEMBLY FOR TRAFFIC SIGNAL SUPPORT STRUCTURES**  
**MAST ARM CONNECTIONS**  
**MA-C-12**

© TxDOT August 1995		DN: MS	CK: JSY	DW: MMF	CK: JSY
REVISIONS		CONT	SECT	JOB	HIGHWAY
5-96		091800		392	VA
5-09					
1-12					
		DIST	COUNTY		SHEET NO.
		DAL	DALLAS, ETC.		57

DISCLAIMER: The use of this standard is governed by the "Texas Engineering Practice Act". No warranty of any kind is made by TxDOT for any purpose whatsoever. TxDOT assumes no responsibility for the conversion of this standard to other formats or for incorrect results or damages resulting from its use.

DATE: 2/14/2024 3:06:48 PM  
 U:\TRAFFIC PROJECTS\0918-00-392 Non-Site 9-24\Microstation Files\058 MA-C(IILSN)-12.dgn

TABLE OF DIMENSIONS						
for ILSN Support Arm Clamp-on Details 1, 2 and 3						
ILSN ARM SIZE	A	F	CONN. BOLTS		PIN BOLTS	
	in.	in.	No.	Dia	No.	Dia
3 in. dia Schedule 40 Pipe	10	4	4	3/4	2	5/8

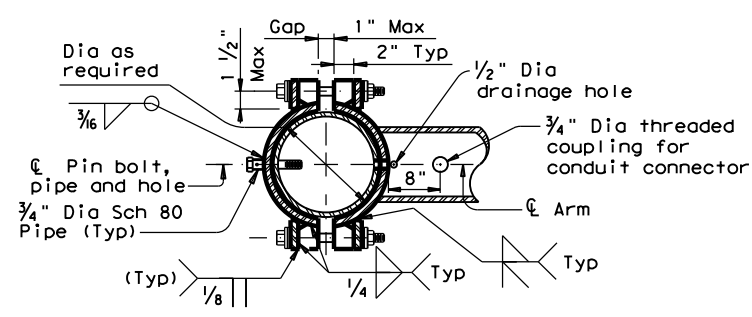

SECTION A-A

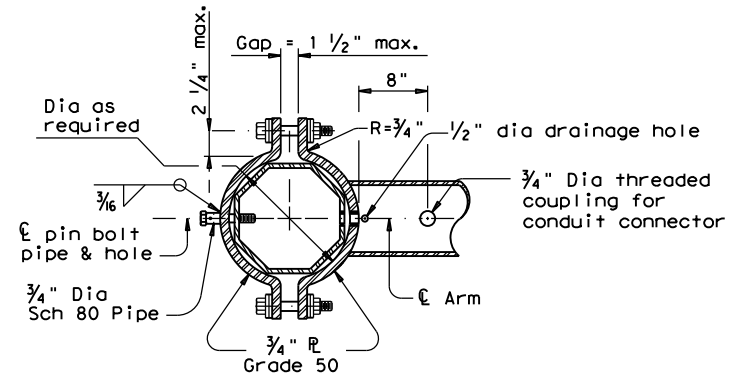

SECTION B-B

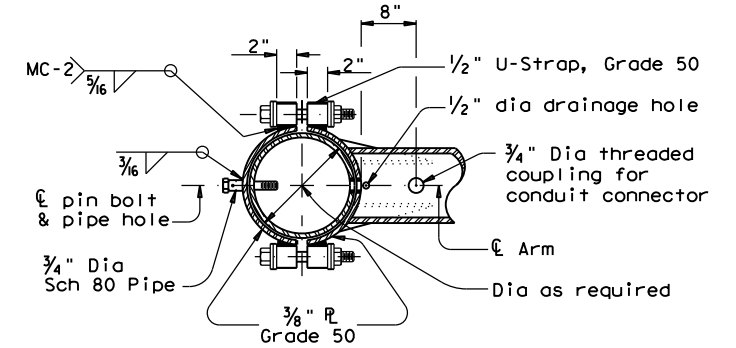

SECTION C-C

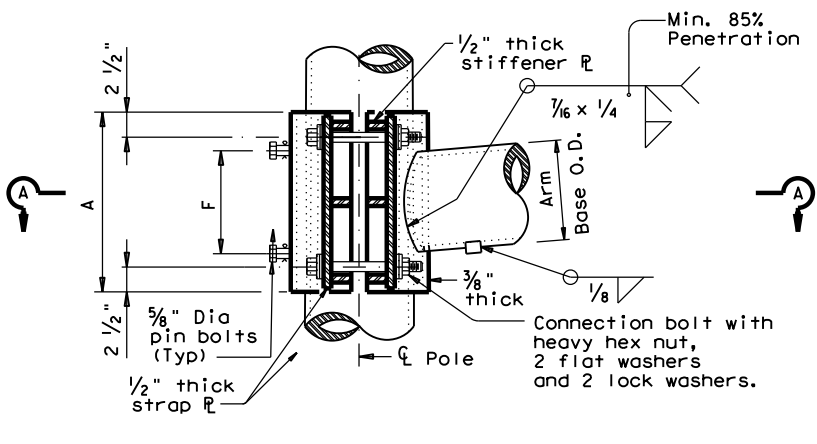

ILSN CLAMP-ON DETAIL 1

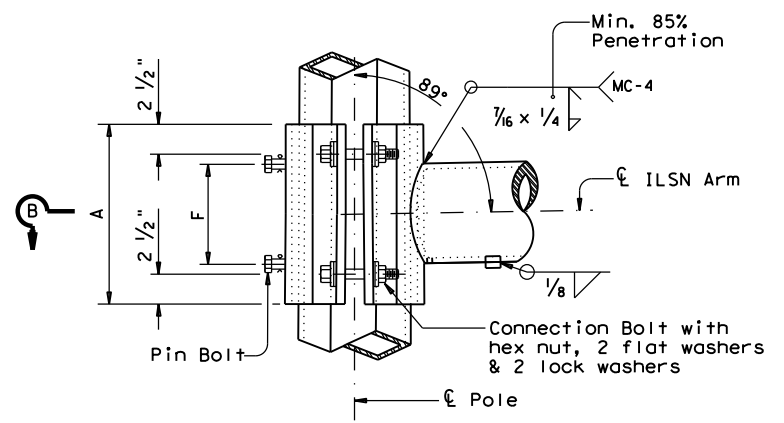

ILSN CLAMP-ON DETAIL 2

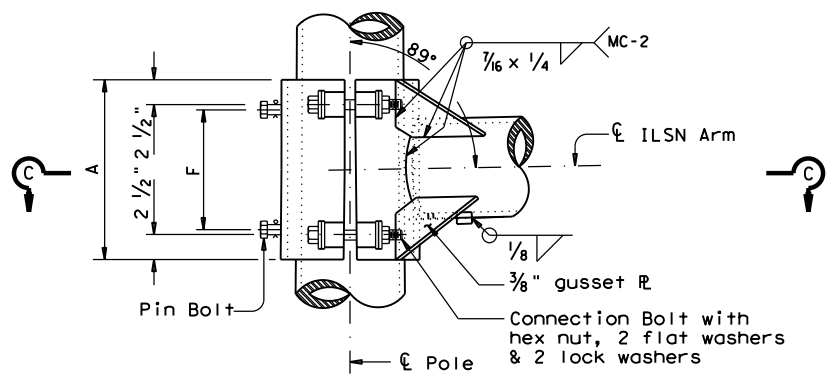

ILSN CLAMP-ON DETAIL 3

**GENERAL NOTES:**

Clamp-on details shall be used for ILSN support arm assemblies. A 1 1/2 inch diameter hole shall be cut in the front clamp plate for wiring access. A matched hole shall be field drilled through the pole to provide wire access after arm is oriented. Deburr both holes.

Where duplicate parts occur on a detail, welds shown for one part shall apply to all similar parts on the details.

Pin bolts are required to prevent rotation of clamp-on arms under design wind forces.

**NOTE:**

Pin bolts shall be A325 with threads excluded from the shear plane. Pin bolt and 3/4 inch diameter pipe shall have 3/16 inch diameter holes for a 1/8 inch diameter galvanized cotter pin. Back clamp plate shall be furnished with a 3/4 inch diameter hole for each pin bolt. An 1/16 inch diameter hole for each pin bolt shall be field drilled through the pole after arm orientations have been approved by the Engineer.

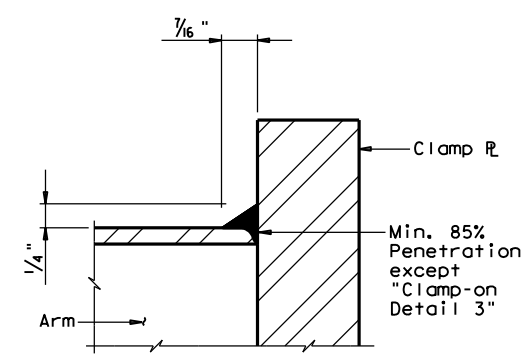

CLAMP-ON ARM  
**ARM BASE WELD DETAILS**

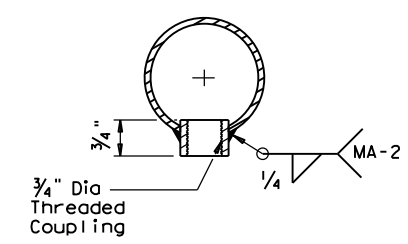

**ILSN ARM COUPLING DETAIL**

**Texas Department of Transportation**  
 Traffic Operations Division  
**STANDARD ASSEMBLY FOR TRAFFIC SIGNAL SUPPORT STRUCTURES**  
 MAST-ARM CONNECTIONS  
**MA-C (ILSN) - 12**

© TxDOT August 1995		DN: MS	CK: JSY	DW: MMF	CK: JSY
REVISIONS		CONT	SECT	JOB	HIGHWAY
5-96	1-12	091800		392	VA
DIST		COUNTY		SHEET NO.	
DAL		DALLAS, ETC.		58	

DISCLAIMER: The use of this standard is governed by the "Texas Engineering Practice Act". No warranty of any kind is made by TxDOT for any purpose whatsoever. TxDOT assumes no responsibility for the conversion of this standard to other formats or for incorrect results or damages resulting from its use.

DATE: 2/14/2024 3:07:52 PM  
 U:\TRAFFIC PROJECTS\0918-00-392 Non-Site 9-24\Microstation Files\059-060 SP80-12(Dal).dgn

STRAIN POLE DESCRIPTION	Pole Type	Founda-tion Type	Maximum Permissible Span Wire Load (lbs.)
26' Pole	A	36-A	5200
30' Pole	B	36-A	4600
30' Pole with Lum.	B	36-A	4400
30' Pole with 20' Mast Arm	C	36-B	5600
30' Pole with 24' Mast Arm	C	36-B	5500
30' Pole with 28' Mast Arm	C	36-B	5300
30' Pole with 32' Mast Arm	C	36-B	5100
30' Pole with 36' Mast Arm	C	36-B	4900
30' Pole with 20' Mast Arm & Lum.	C	36-B	5300
30' Pole with 24' Mast Arm & Lum.	C	36-B	5200
30' Pole with 28' Mast Arm & Lum.	C	36-B	5000
30' Pole with 32' Mast Arm & Lum.	C	36-B	4800
30' Pole with 36' Mast Arm & Lum.	C	36-B	4500
34' Pole	D	36-B	5600
34' Pole with Lum.	D	36-B	5400

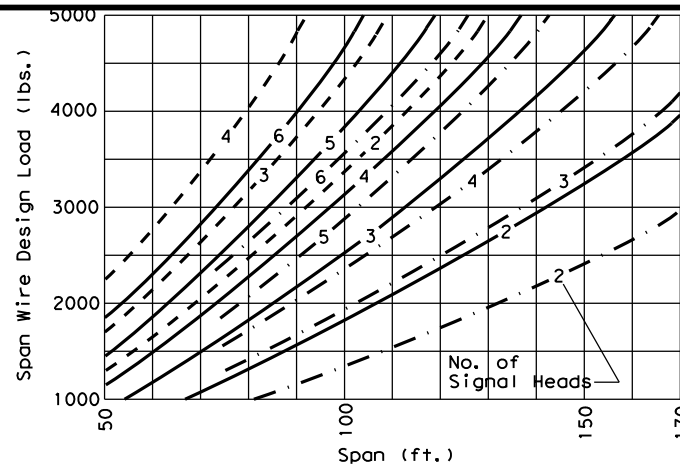

② SIGNALS WITH 12-INCH LENS

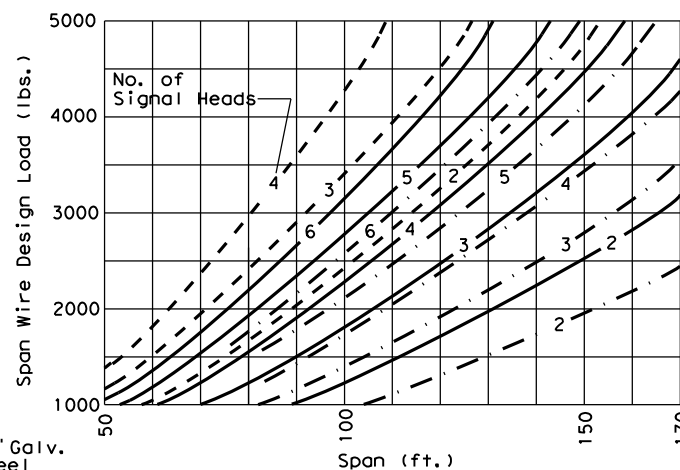

② SIGNALS WITH 8-INCH LENS

Signal Head Type	Wt. Per Head	Wind Area
5-Section, 12" Lens	125 lbs	9.6 sq. ft.
5-Section, 8" Lens	70 lbs	4.8 sq. ft.
3-Section, 12" Lens	75 lbs	5.64 sq. ft.
3-Section, 8" Lens	45 lbs	3.0 sq. ft.

Effective projected design wind area (actual area times drag coefficient)

--- Sag = 4'-6" (26' or 30' Pole)  
 — Sag = 8'-0" (30' or 34' Pole)  
 - - - Sag = 11'-6" (34' Pole)

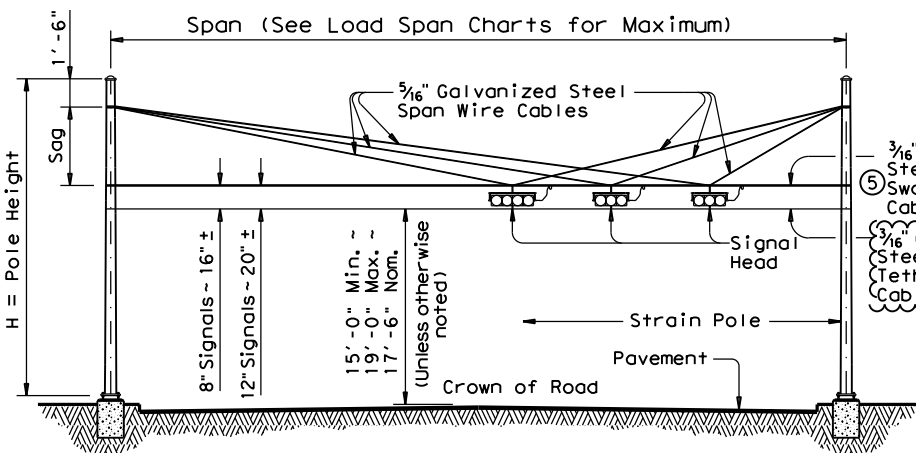

STRAIN POLE ELEVATIONS HORIZONTAL SIGNALS

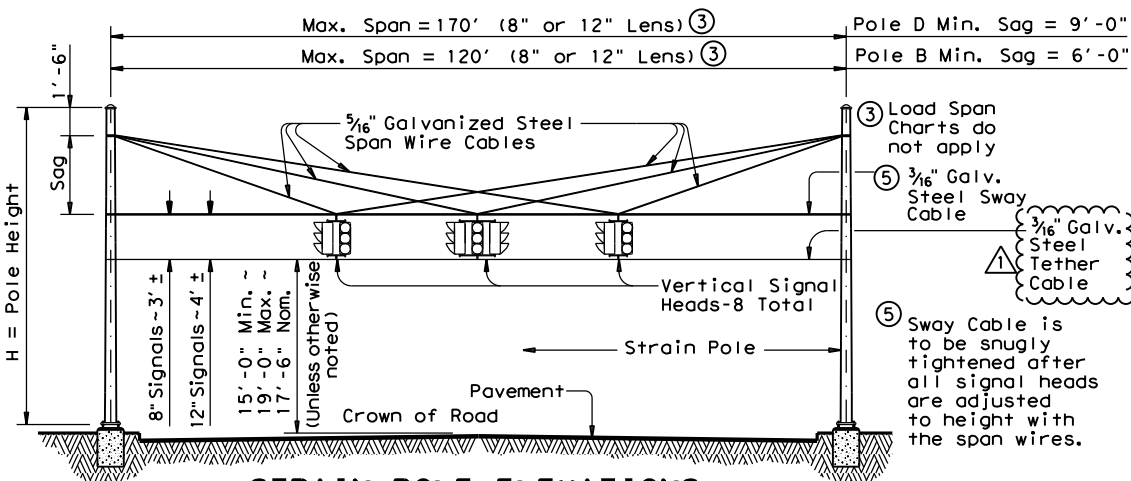

STRAIN POLE ELEVATIONS VERTICAL SIGNALS

(Mast arms are not used with vertical signals)

SHIPPING PARTS LIST

Poles (Without Traffic Signal Arm)						
Pole Type	Strain poles with Luminaire			Strain poles without Luminaire		
	Description	Designation	Quantity	Description	Designation	Quantity
A				26' Strain Pole	SP 26 A-80	
B	30' Strain Pole	SPL 30 B-80		30' Strain Pole	SP 30 B-80	
D	34' Strain Pole	SPL 34 D-80		34' Strain Pole	SP 34 D-80	

Poles (With Traffic Signal Arm)						
Pole Type	Strain poles with Luminaire			Strain poles without Luminaire		
	Description	Designation	Quantity	Description	Designation	Quantity
C	30' SPw/TS Arm	SPL 30 C-80		30' SPw/TS Arm	SP 30 C-80	

Traffic Signal Arms (For Type C poles)						
Nominal Arm Length	Type I Arm (1 Signal)		Type II Arm (2 Signals)		Type III Arm (3 Signals)	
	ft.	Designation	Designation	Quantity	Designation	Quantity
20	20I-80					
24	24I-80		24 II -80			
28	28I-80		28 II -80			
32			32 II -80		32 III -80	
36			36 II -80		36 III -80	

Anchor Bolt Assemblies (1 per pole)

Anchor Bolt Diameter	Anchor Bolt Length	Quantity
1 3/4"	3'-10"	
2"	4'-3"	

Luminaire Arms

Nominal Arm Length	Quantity
8' Arm	

Each Anchor Bolt Assembly consists of the following: Top and Bottom templates, 4 anchor bolts, 8 nuts, 8 flat washers, and 4 nut anchor devices (Type 2) per Standard Drawing "TS-FD".

① See Sheet "DMA-80"

Pole Type	ROUND POLES				POLYGONAL POLES			
	D <sub>B</sub>	D <sub>T</sub>	(4)thk	H	D <sub>B</sub>	D <sub>T</sub>	(4)thk	H
A	12.5	8.9	.239	26	13.0	9.0	.239	26
B	13.5	9.3	.239	30	14.0	9.0	.239	30
C	15.5	11.3	.239	30	16.0	11.0	.239	30
D	15.5	10.7	.239	34	16.0	11.0	.239	34

D<sub>B</sub> = Pole Base O.D. D<sub>T</sub> = Pole Top O.D. H = Pole Height

④ Thickness shown are minimum, thicker materials may be used.

MODIFICATIONS:

▲ ADDED BOTTOM STEEL TETHER CABLE. (2/12)

Texas Department of Transportation

**TRAFFIC SIGNAL SUPPORT STRUCTURES STRAIN POLE ASSEMBLIES (80 MPH WIND ZONE) SP-80(1)-12(DAL)**

© TxDOT March 1996		DN: MS	CK: JSY	DW: BR	CK: JSY
REVISIONS		CONT	SECT	JOB	HIGHWAY
6-96 1-12		091800		392	VA
		DIST	COUNTY	SHEET NO.	
		DAL	DALLAS, ETC.	59	

DISCLAIMER: The use of this standard is governed by the "Texas Engineering Practice Act". No warranty of any kind is made by TxDOT for any purpose whatsoever. TxDOT assumes no responsibility for the conversion of this standard to other formats or for incorrect results or damages resulting from its use.

DATE: 2/14/2024 3:08:12 PM  
 U:\TRAFFIC PROJECTS\0918-00-392 Non-Site 9-24\Microstation Files\059-060 SP80-12(Dal).dgn

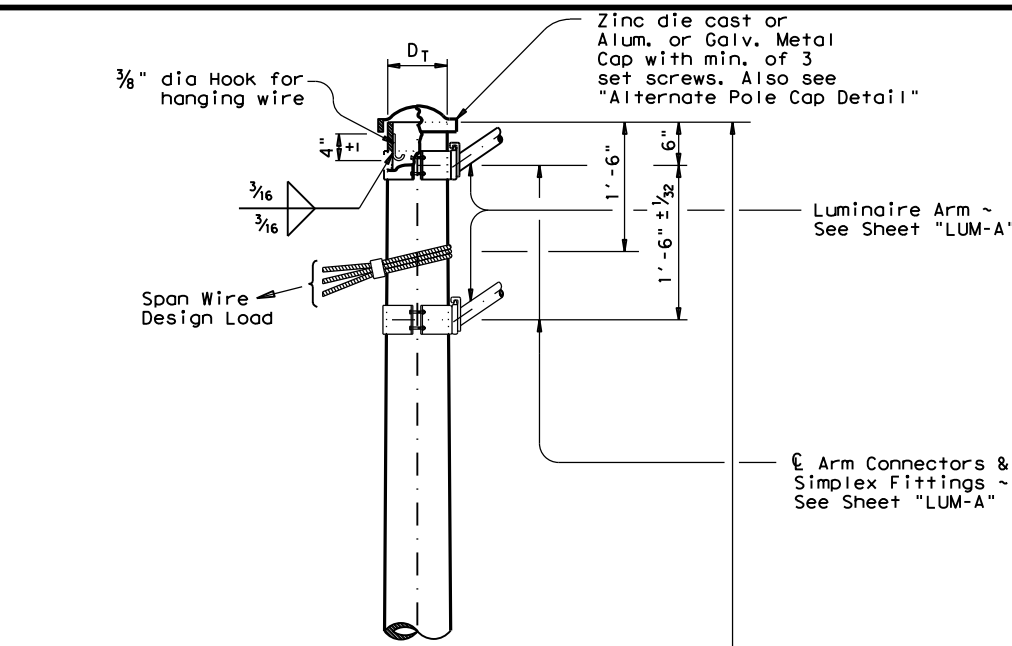

**DETAIL A**

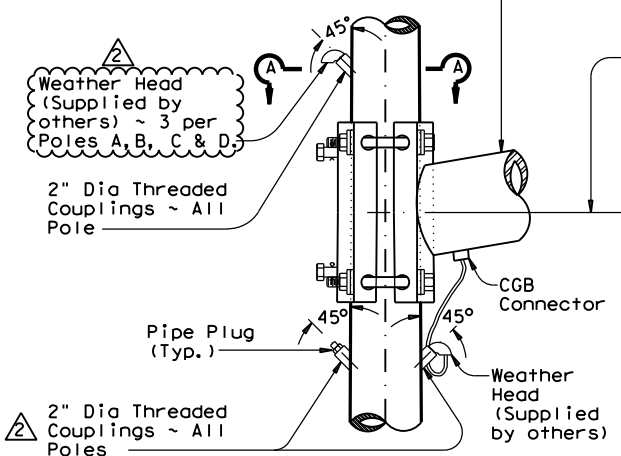

**DETAIL B**

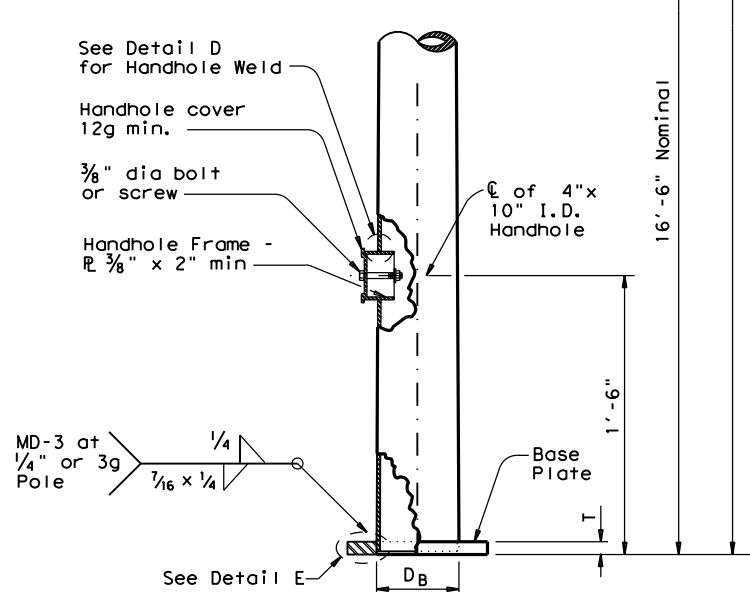

**DETAIL C**

**POLE ELEVATION**

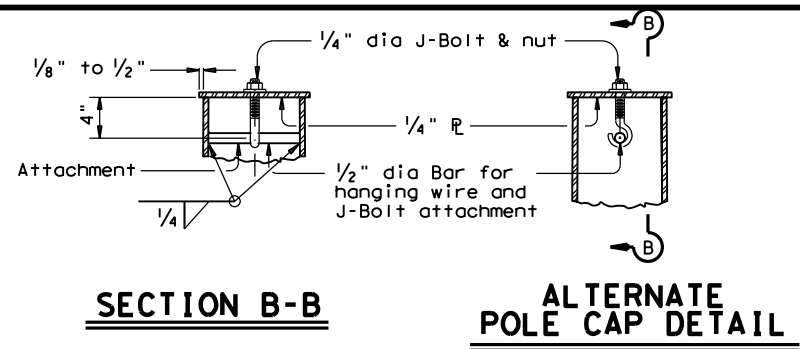

**SECTION B-B  
 ALTERNATE POLE CAP DETAIL**

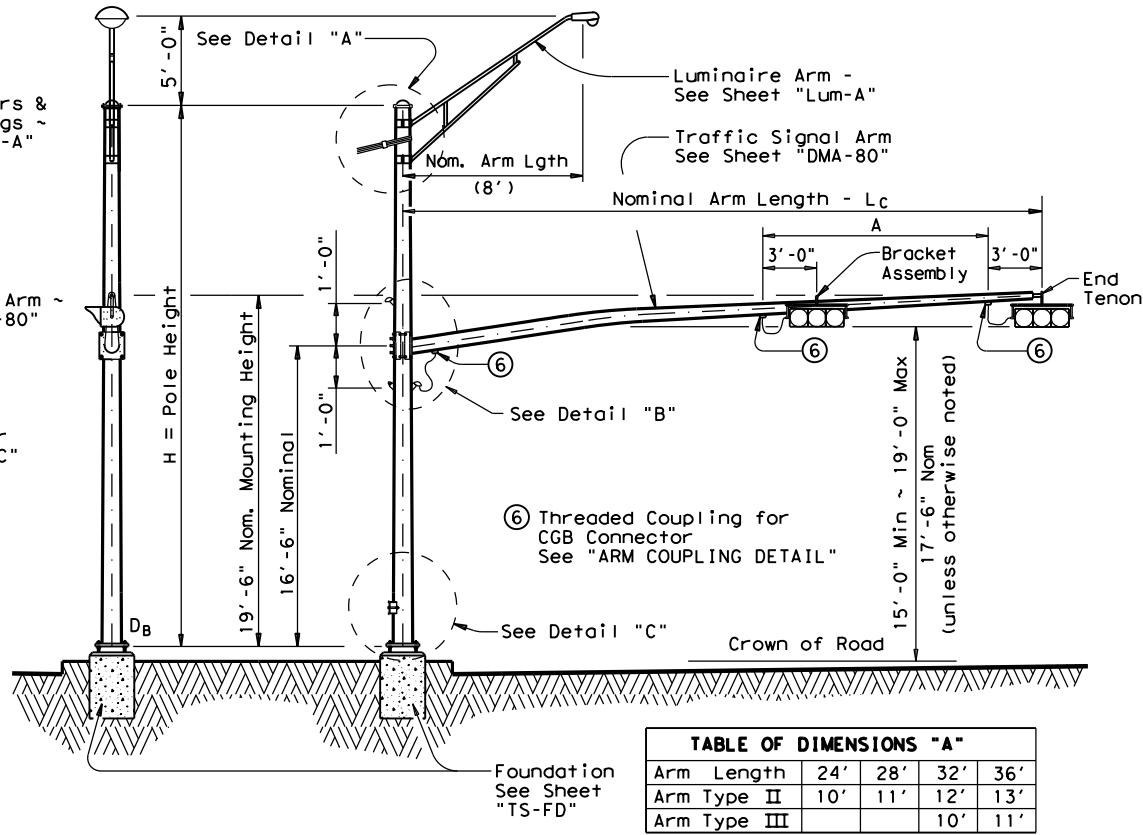

**STRUCTURE ASSEMBLY**

**TABLE OF DIMENSIONS "A"**

Arm Length	24'	28'	32'	36'
Arm Type II	10'	11'	12'	13'
Arm Type III			10'	11'

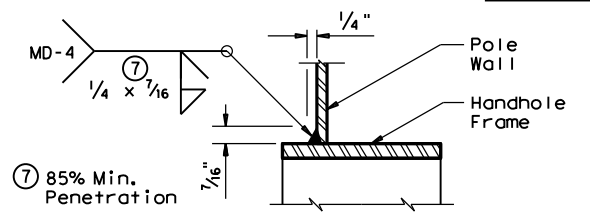

**DETAIL D**

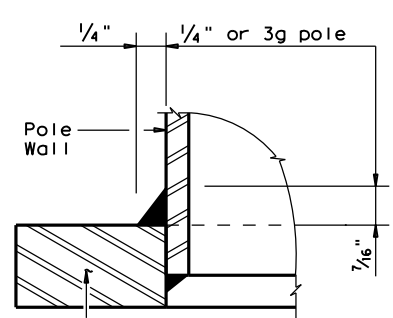

**DETAIL E**

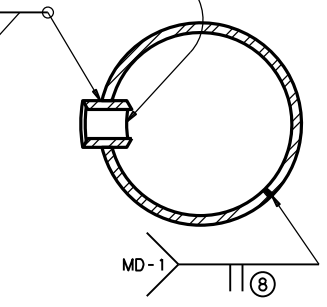

**SECTION A-A  
 (Pole Coupling and Seam Weld Details)**

Ⓢ 60% Min. penetration, except 100% penetration within 6" of circumferential base welds.

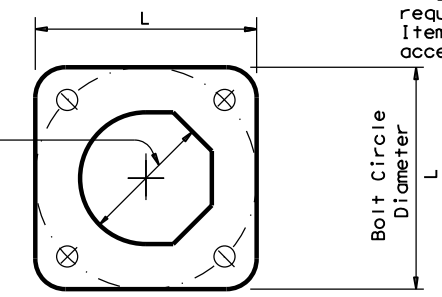

**BASE PLATE PLAN**

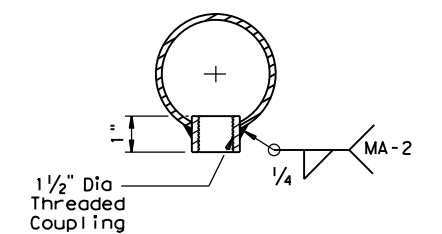

**ARM COUPLING DETAIL**

⚠ CHANGED TO 3 WEATHERHEAD ACCESS POINTS FOR POLES A, B, C AND D(3/12).

MATERIALS	
Round Shafts or Polygonal Shafts <sup>⑨</sup>	ASTM A595 Gr.A, A588, A1008 HSLAS Gr.50 Class 2, A1011 HSLAS Gr.50 Class 2, A572 Gr.50 or A1011 SS Gr.50 <sup>⑩</sup>
Plates <sup>⑨</sup>	ASTM A36, A588, or A572 Gr.50
Connection Bolts	ASTM A325 except where noted
Pin Bolts	ASTM A325
Pipe <sup>⑨</sup>	ASTM A53 Gr.B, A501, A1008 HSLAS-F Gr.50, A1011 HSLAS-F Gr.50
Steel Cable	ASTM A475, 7 Wire Utilities Grade
Misc. Hardware	Galvanized steel or stainless steel or as noted

⑨ ASTM A572, A1008 HSLAS, A1011 HSLAS, A1008 HSLAS-F, A1011 HSLAS-F, or A1011 SS may have higher yield strengths but shall not have less elongation than the grade indicated.

⑩ ASTM A1011 SS Gr.50 shall also have a minimum elongation of 18 percent in 8 inches or 23 percent in 2 inches. Material thickness in excess of those stipulated under A1011 SS will be acceptable providing the material meets all other A1011 SS requirements and the requirements of this item.

**GENERAL NOTES**

Design conforms to 1994 AASHTO Standard Specifications for Structural Supports for Highway Signs, Luminaires, and Traffic Signals and Interim Specifications thereto. Design Wind Speed equals 80 mph plus a 1.3 gust factor. The maximum permissible span wire design loads tabulated are calculated at a stress load of 1.4 times the basic allowable stress. A simultaneous wind on the pole, mast arm, and luminaire is also included.

See standard sheet "DMA-80" for details of clamp-on traffic signal arms, sheet "MA-C" for traffic signal arm connection details, sheet "LUM-A" for luminaire arm and connection details, and sheet "TS-FD" for anchor bolt and foundation details.

Fabrication shall be in accordance with Item 686, "Traffic Signal Pole Assemblies (Steel)" and with the details, dimensions, and weld procedures shown herein. Weld references call for preapproved weld procedures which the Fabricator must obtain prior to fabrication. Materials, fabrication tolerances, and shipping practices shall meet the requirements of this sheet and Item 686, "Traffic Signal Pole Assemblies (Steel)".

Unless otherwise noted, all parts shall be galvanized in accordance with Item 445, "Galvanizing", after fabrication.

Deviation from the details and dimensions shown herein require submission of shop drawings in accordance with Item 441, "Steel Structures". Alternate designs are not acceptable.

Foundation Type	Anchor Bolt Diameter	Bolt Hole Diameter	Bolt Circle Diameter	Base Pl. Dim. L x T
36-A	1 3/4"	2"	19"	19" x 1 3/4"
36-B	2"	2 1/4"	21"	21" x 2"

**Texas Department of Transportation**

**TRAFFIC SIGNAL SUPPORT STRUCTURES STRAIN POLE ASSEMBLIES (80 MPH WIND ZONE) SP-80(2)-12(DAL)**

© TxDOT March 1996	DN: MS	CK: JSY	DW: BR	CK: JSY
6-96 1-12	REVISIONS	CONT. SECT.	JOB	HIGHWAY
		091800	392	VA
		DIST.	COUNTY	SHEET NO.
		DAL	DALLAS, ETC.	60

DISCLAIMER: The use of this standard is governed by the "Texas Engineering Practice Act". No warranty of any kind is made by TxDOT for any purpose whatsoever. TxDOT assumes no responsibility for the conversion of this standard to other formats or for incorrect results or damages resulting from its use.

DATE: 2/14/2024 3:08:49 PM  
 U:\TRAFFIC PROJECTS\0918-00-392 Non-Site 9-24\Microstation Files\061 RFBA-13.dgn

**GENERAL NOTES:**

- Details show a typical warning sign with two flashing beacon heads, other arrangements are possible. When only one beacon is required, install the upper beacon.
- See Item 685, "Roadside Flashing Beacon Assemblies" for further requirements.
- See SMD standard sheets for lateral and vertical clearances and sign mounting details. Install signs as shown on the sign layout sheets.
- Use either a Screw-In Type Anchor Foundation or a Drilled Shaft Foundation as shown elsewhere in the plans. When plans require a Drilled Shaft Foundation, see standard sheet TS-FD. Install the Screw-In Type Anchor Foundation as per manufacturer's recommendations. On a slope, install one edge at ground level. Screw-In/Drilled Shaft Foundation is subsidiary to Item 685. Installation of a ground rod is not required for solar powered flashing beacon assemblies.
- When used, provide Screw-In Type Anchor Foundations as shown on TxDOT's Material Producer List (MPL) in the file "Highway Traffic Signals".
- Install beacon heads as shown here, as shown elsewhere on the plans, or as directed. Use hardware specifically designed for mounting beacon heads on poles.
- Conduit in foundation and within 6 in. of foundation is subsidiary to the Item 685, "Roadside Flashing Beacon Assemblies."
- Unless otherwise shown on the plans, pole shaft shall be one piece, Schedule 40 Aluminum pipe, ASTM B429 or B221 (Alloy 6061-T6 only). Aluminum conduit will not develop the necessary strength and will not be allowed.
- Per manufacturer's recommendations, engage all threads on the pedestal pole base and pipe unless the pipe is fully seated into base. In high winds, use a pole and base collar assembly to add strength and prevent loosening of connection.
- Provide single pole non-fused watertight breakaway electrical connectors for frangible pedestal pole bases, as shown on TxDOT's MPL in the file "Roadway Illumination and Electrical Supplies." Approved models are listed under Item 685. For ungrounded (hot) conductors, install a breakaway connector with a dummy fuse slug. For grounded (neutral) conductors, install a breakaway connector with a white colored marking and a permanently installed dummy fuse (slug).
- Provide clearance as shown above the sidewalk or pavement grade at the edge of the road. When a bottom beacon is not used, mount the bottom of the sign at least 7 ft. above the sidewalk or pavement grade at the edge of the road.
- Make connections to ground rods according to NEC. Ground rod clamps shall be listed for their intended purpose.
- Ensure height of conduit and ground rod is below top of anchor bolts.

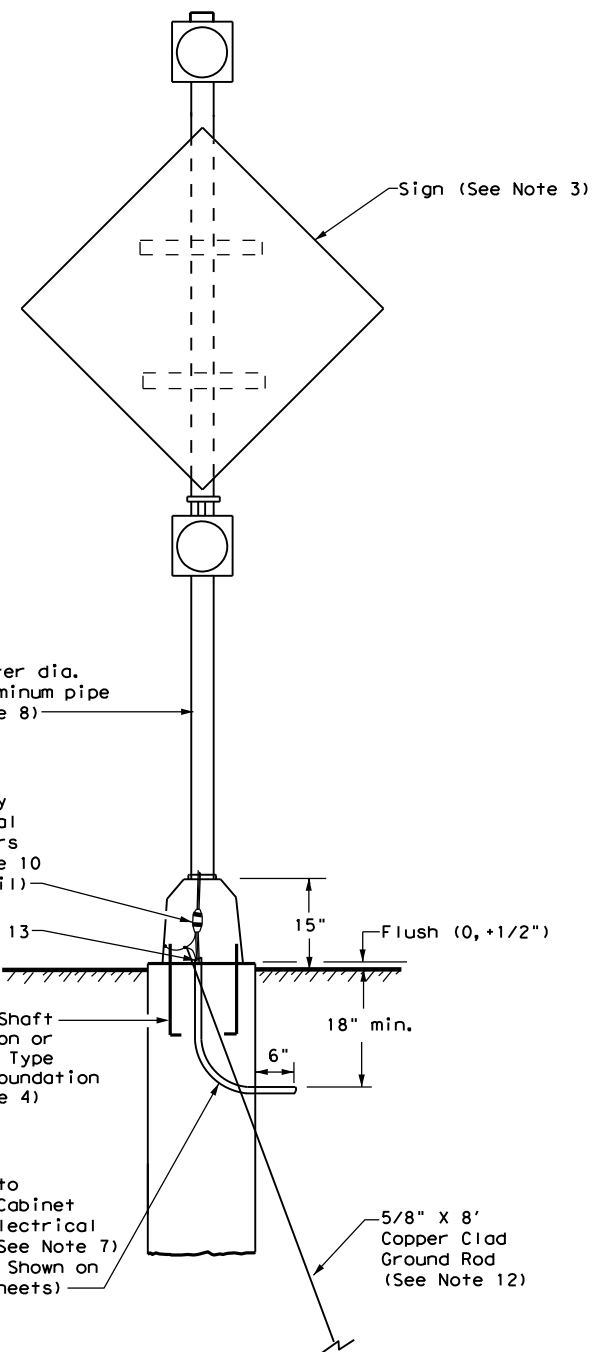

**FRONT**

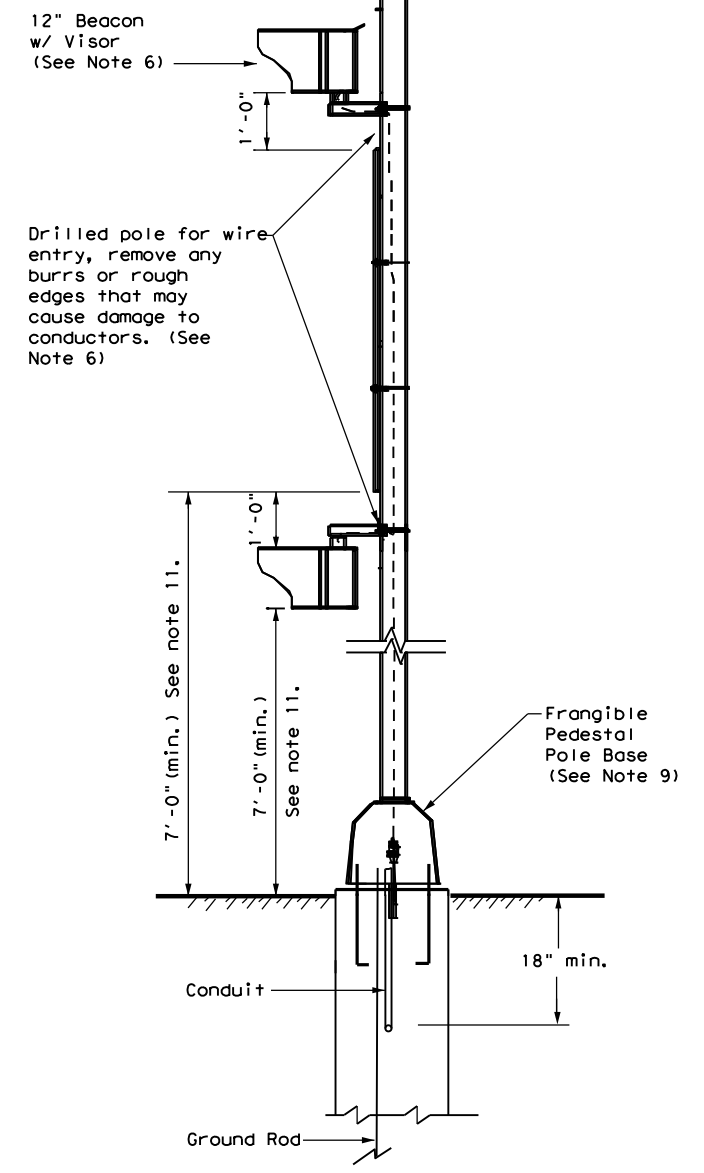

**SIDE**

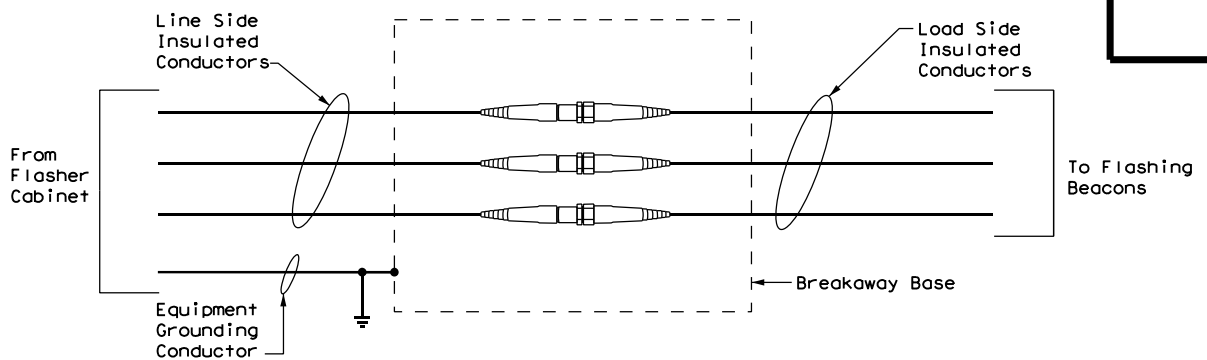

**NON-FUSED BREAKAWAY ELECTRICAL CONNECTORS**

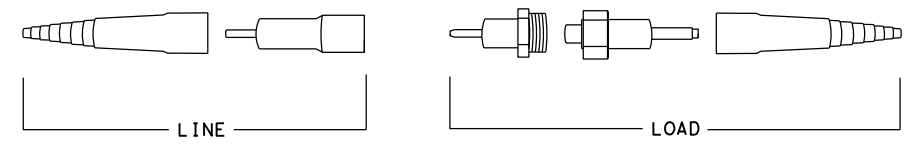

**NON-FUSED BREAKAWAY ELECTRICAL CONNECTORS  
EXPLODED VIEW**

**ROADSIDE FLASHING BEACON ASSEMBLY**

**RFBA-13**

FILE: rfa-13.dgn	DN: TxDOT	CK: TxDOT	DW: TxDOT	CR: TxDOT
© TxDOT January 1992	CONT	SECT	JOB	HIGHWAY
REVISIONS	091800		392	VA
5-93 12-04	DIST	COUNTY		SHEET NO.
10-93 3-13	DAL	DALLAS, ETC.		61
4-98				

DISCLAIMER: The use of this standard is governed by the "Texas Engineering Practice Act". No warranty of any kind is made by TxDOT for any purpose whatsoever. TxDOT assumes no responsibility for the conversion of this standard to other formats or for incorrect results or damages resulting from its use.

DATE: 2/14/2024 3:09:25 PM  
 U:\TRAFFIC PROJECTS\0918-00-392 Non-Site 9-24\Microstation Files\062 SPRFBA(1)-13.dgn

**GENERAL NOTES:**

- Details show a typical warning sign with two flashing beacon heads, other arrangements are possible. When only one beacon is required, install the upper beacon.
- See Item 685, "Roadside Flashing Beacon Assemblies" for further requirements.
- See SMD standard sheets for lateral and vertical clearances and sign mounting details. Install signs as shown on the sign layout sheets.
- Use either a Screw-In Type Anchor Foundation or a Drilled Shaft Foundation as shown elsewhere in the plans. When plans require a Drilled Shaft Foundation, see standard sheet TS-FD. Install the Screw-In Type Anchor Foundation as per manufacturer's recommendations. On a slope, install one edge at ground level. Screw-In/Drilled Shaft Foundation is subsidiary to Item 685. Installation of a ground rod is not required for solar powered flashing beacon assemblies.
- When used, provide Screw-In Type Anchor Foundations as shown on TxDOT's Material Producer List (MPL) in the file "Highway Traffic Signals".
- Use materials specifically designed for attaching cabinets, beacon heads, solar panels, etc., to poles.
- Install beacon heads as shown here, as shown elsewhere on the plans, or as directed. Use hardware specifically designed for mounting beacon heads on poles.
- Conduit in foundation and within 6 in. of foundation is subsidiary to the Item 685, "Roadside Flashing Beacon Assemblies."
- Per manufacturer's recommendations, engage all threads on the pedestal pole base and pipe unless the pipe is fully seated into base. In high winds, use a pole and base collar assembly to add strength and prevent loosening on connection.
- Provide single pole non-fused watertight breakaway electrical connectors for frangible pedestal pole bases, as shown on TxDOT's MPL in the file "Roadway Illumination and Electrical Supplies." Approved models are listed under Item 685. For ungrounded (hot) conductors, install a breakaway connector with a dummy fuse slug. For grounded (neutral) conductors, install a breakaway connector with a white colored marking and a permanently installed dummy fuse (slug).
- Install the batteries in a battery box. Place the batteries on a 3/16" thick plastic sheet and connect together. Place a plastic cover (battery bell jar) over the top of each battery and secure the battery bell jar to the battery with a strap. The batteries, bell jars, straps and 3/16" plastic sheet are subsidiary to the Item 685, "Roadside Flashing Beacon Assemblies." When required, install batteries in the flasher cabinet. Wire batteries according to manufacturers recommendations. Provide the number of batteries as required by the manufacturer.
- See standard sheet Electrical Details (ED) for additional requirements regarding the installation of ground boxes/battery boxes, conduit, and cabinets.
- Provide clearance as shown above the sidewalk or pavement grade at the edge of the road. When a bottom beacon is not used, mount the bottom of the sign at least 7 ft. above the sidewalk or pavement grade at the edge of the road.
- Unless otherwise shown on the plans, pole shaft shall be one piece, Schedule 40 Aluminum pipe, ASTM B429 or B221 (Alloy 6061-T6 only). Aluminum conduit will not develop the necessary strength and will not be allowed.
- Orient solar panel for optimum exposure to sunlight (face to the south). Prior to installation, check the location to ensure there is no overhead obstruction that would block the solar panel from receiving full sunlight. Unless specified elsewhere, mount a minimum of 14' above grade.
- Ensure height of conduit is below top of anchor bolts.

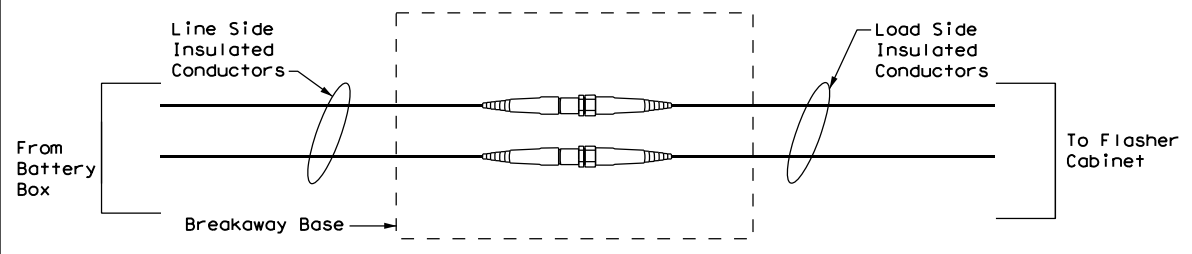
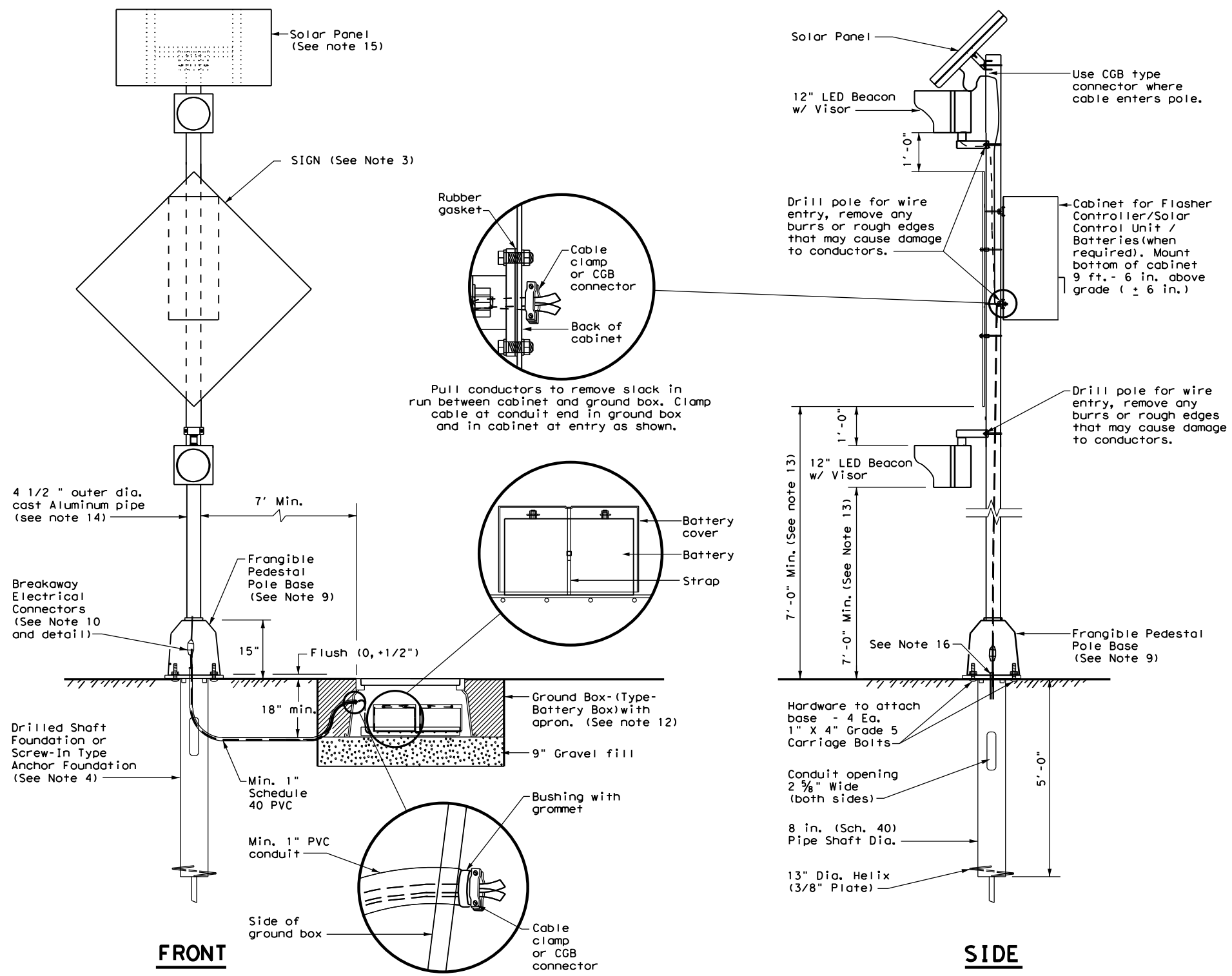

**NON-FUSED BREAKAWAY ELECTRICAL CONNECTORS**

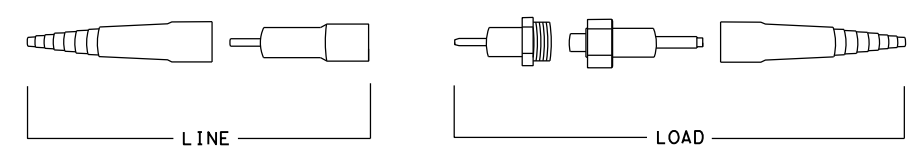

**NON-FUSED BREAKAWAY ELECTRICAL CONNECTORS  
EXPLODED VIEW**

<b>SOLAR POWERED ROADSIDE FLASHING BEACON ASSEMBLY DETAILS</b>			
<b>SPRFBA(1)-13</b>			
FILE: spb1-13.dgn	DW: TxDOT	CK: TxDOT	DW: TxDOT
© TxDOT May 2003	CONT	SECT	JOB
REVISIONS	091800	392	VA
12-04	DIST	COUNTY	SHEET NO.
3-13	DAL	DALLAS, ETC.	62

DISCLAIMER: The use of this standard is governed by the "Texas Engineering Practice Act". No warranty of any kind is made by TxDOT for any purpose whatsoever. TxDOT assumes no responsibility for the conversion of this standard to other formats or for incorrect results or damages resulting from its use.

DATE: 2/14/2024 3:09:45 PM  
 U:\TRAFFIC PROJECTS\0918-00-392 Non-Site 9-24\Microstation Files\063 SPRFBA(3)-13.dgn

**GENERAL NOTES:**

- Details show a typical warning sign with two flashing beacon heads, other arrangements are possible. When only one beacon is required, install the upper beacon.
- See Item 685, "Roadside Flashing Beacon Assemblies" for further requirements.
- See SMD standard sheets for lateral and vertical clearances and sign mounting details. Install signs as shown on the sign layout sheets.
- Use either a Screw-In Type Anchor Foundation or a Drilled Shaft Foundation as shown elsewhere in the plans. When plans require a Drilled Shaft Foundation, see standard sheet TS-FD. Install the Screw-In Type Anchor Foundation as per manufacturer's recommendations. On a slope, install one edge at ground level. Screw-In/Drilled Shaft Foundation is subsidiary to Item 685. Installation of a ground rod is not required for solar powered flashing beacon assemblies.
- When used, provide Screw-In Type Anchor Foundations as shown on TxDOT's Material Producer List (MPL) in the file "Highway Traffic Signals".
- Provide clearance as shown above the sidewalk or pavement grade at the edge of the road. When a bottom beacon is not used, mount the bottom of the sign at least 7 ft. above the sidewalk or pavement grade at the edge of the road.
- Use materials specifically designed for attaching cabinets, beacon heads, solar panels, etc., to poles.
- Conduit in foundation and within 6 in. of foundation is subsidiary to the Item 685, "Roadside Flashing Beacon Assemblies."
- Per manufacturer's recommendations, engage all threads on the pedestal pole base and pipe unless the pipe is fully seated into base. In high winds, use a pole and base collar assembly to add strength and prevent loosening on connection.
- Install beacon heads as shown here, as shown elsewhere on the plans, or as directed. Use hardware specifically designed for mounting beacon heads on poles.
- Install the cable clamp in the bottom third of the back of the cabinet. See Detail A.
- Provide single pole non-fused watertight breakaway electrical connectors for frangible pedestal pole bases, as shown on TxDOT's MPL in the file "Roadway Illumination and Electrical Supplies". Approved models are listed under Item 685. For ungrounded (hot) conductors, install a breakaway connector with a dummy fuse (slug). For grounded (neutral) conductors, install a breakaway connector with a white colored marking and a permanently installed dummy fuse (slug).
- Install the batteries in a battery box. Place the batteries on a 3/16" thick plastic sheet and connect together. Place a plastic cover (battery bell jar) over the top of each battery and secure the battery bell jar to the battery with a strap. The batteries, bell jars, straps and 3/16" plastic sheet are subsidiary to the Item 685, "Roadside Flashing Beacon Assemblies." When required, install batteries in the flasher cabinet. Wire batteries according to manufacturer's recommendations. Provide the number of batteries as required by the manufacturer.
- See standard sheet Electrical Details (ED) for additional requirements regarding the installation of ground boxes/battery boxes, conduit, and cabinets.
- Unless otherwise shown on the plans or recommended by the manufacturer, use the following table to determine the wire size from cabinet to beacons.

Distance from Cabinet to Beacons (ft.)	Minimum Required Wire Size (AWG)
0 - 35	#14
35 - 60	#12
60 - 100	#10
> 100	#8

- Unless otherwise shown on the plans, pole shaft shall be one piece, Schedule 40 Aluminum pipe, ASTM B429 or B221 (Alloy 6061-T6 only). Aluminum conduit will not develop the necessary strength and will not be allowed.
- Orient solar panel for optimum exposure to sunlight (face to the south). Prior to installation, check the location to ensure there is no overhead obstruction that would block the solar panel from receiving full sunlight. Unless specified elsewhere, mount a minimum of 14' above grade.
- Ensure height of conduit is below top of anchor bolts.

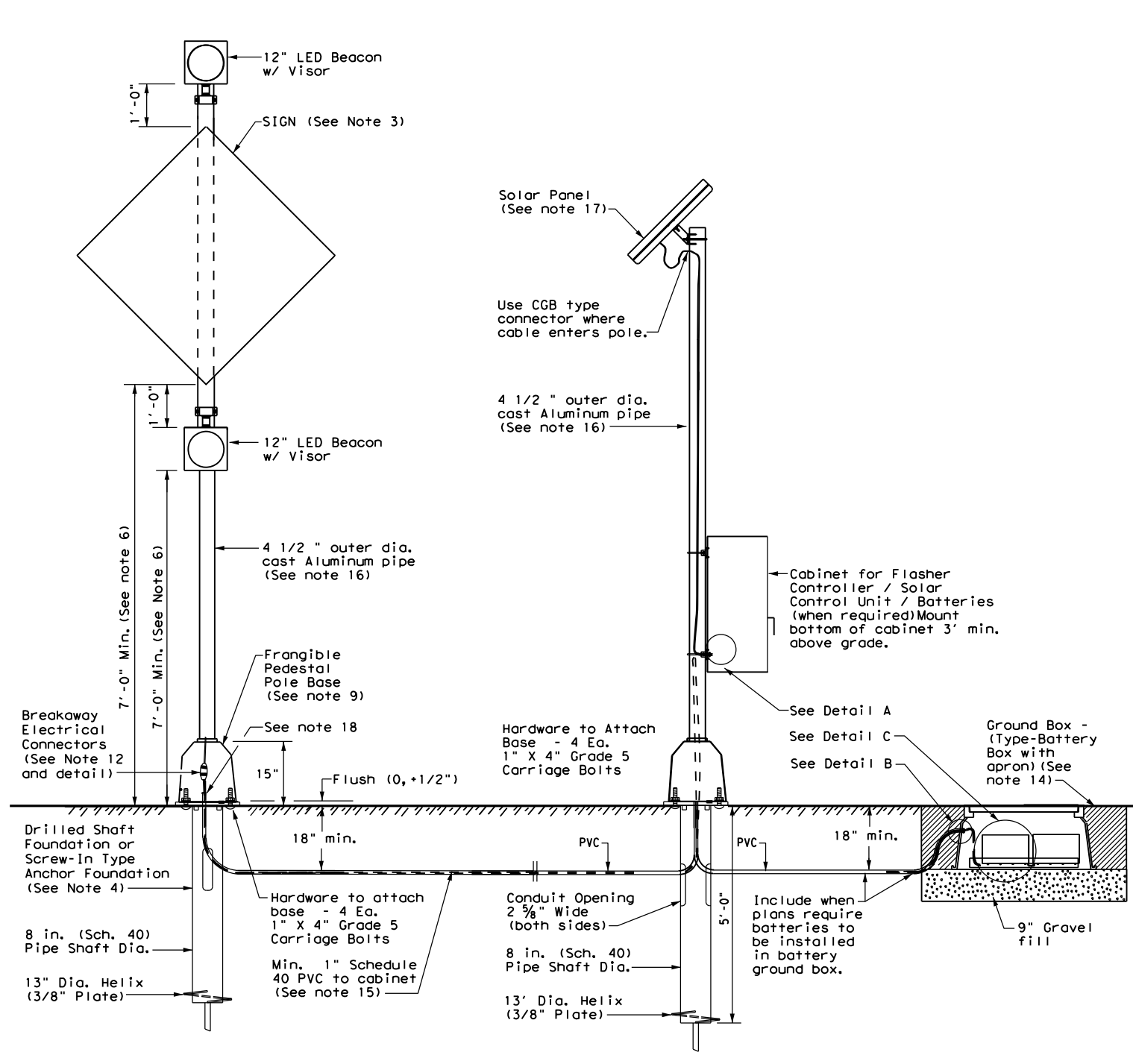

**DETAIL FOR SOLAR PANEL, CABINET, AND BATTERIES LOCATED OUT OF CLEAR ZONE ON SEPARATE ALUMINUM POLE ASSEMBLY**

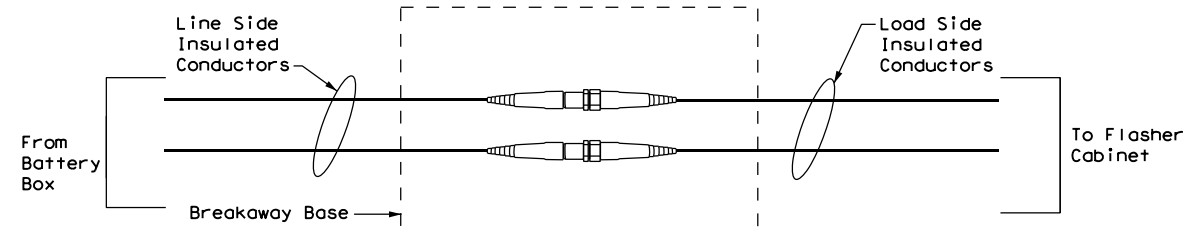
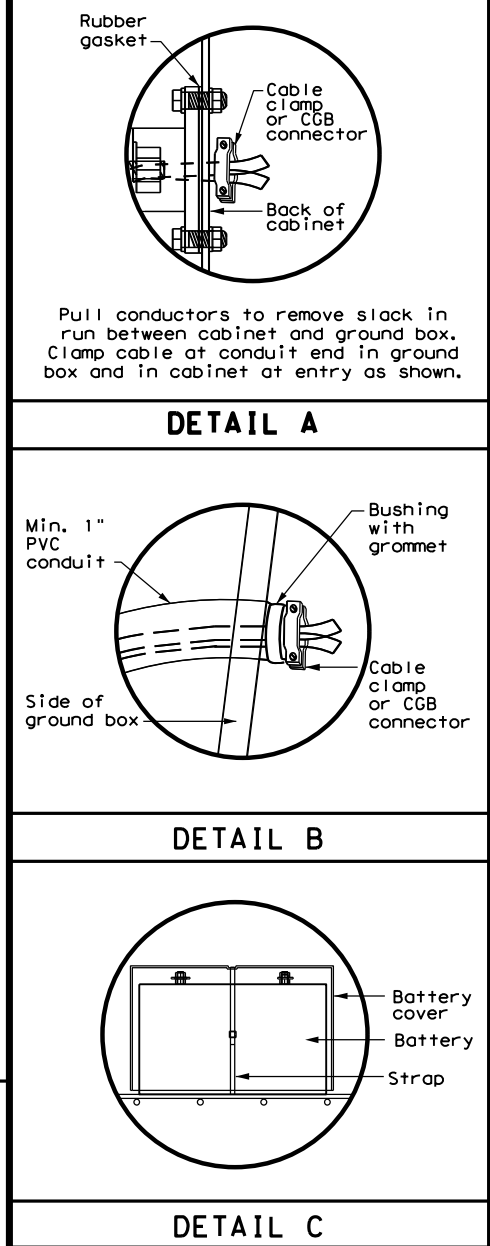

**NON-FUSED BREAKAWAY ELECTRICAL CONNECTORS**

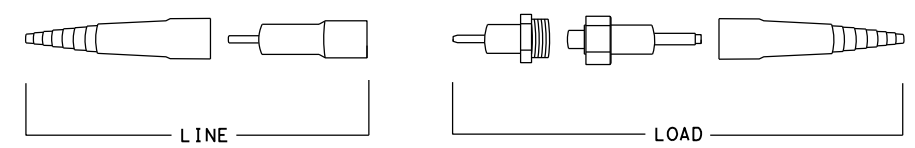

**NON-FUSED BREAKAWAY ELECTRICAL CONNECTORS EXPLODED VIEW**

**SOLAR POWERED ROADSIDE FLASHING BEACON ASSEMBLY DETAILS (ALUMINUM)**  
**SPRFBA (3) - 13**

FILE: spb3-13.dgn	DN: TxDOT	CK: TxDOT	DW: TxDOT	CR: TxDOT
© TxDOT May 2003	CONT	SECT	JOB	HIGHWAY
REVISIONS	091800		392	VA
12-04	DIST	COUNTY		SHEET NO.
3-13	DAL	DALLAS, ETC.		63

DISCLAIMER: The use of this standard is governed by the "Texas Engineering Practice Act". No warranty of any kind is made by TxDOT for any purpose whatsoever. TxDOT assumes no responsibility for the conversion of this standard to other formats or for incorrect results or damages resulting from its use.

DATE: 2/14/2024 3:10:41 PM  
 U:\TRAFFIC PROJECTS\0918-00-392 Non-Site 9-24\Microstation Files\064 LUM-A.dgn

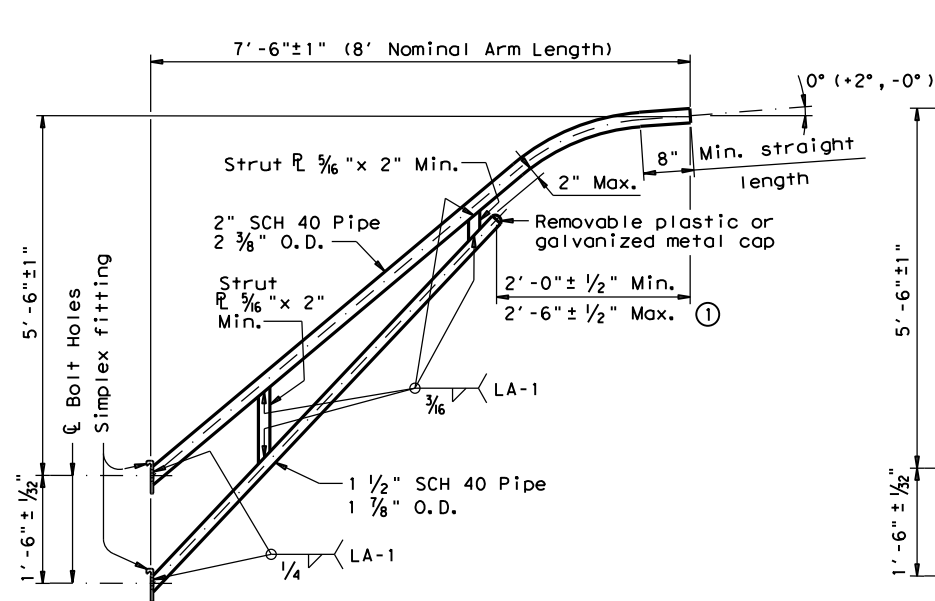

**8-FOOT LUMINAIRE ARM**

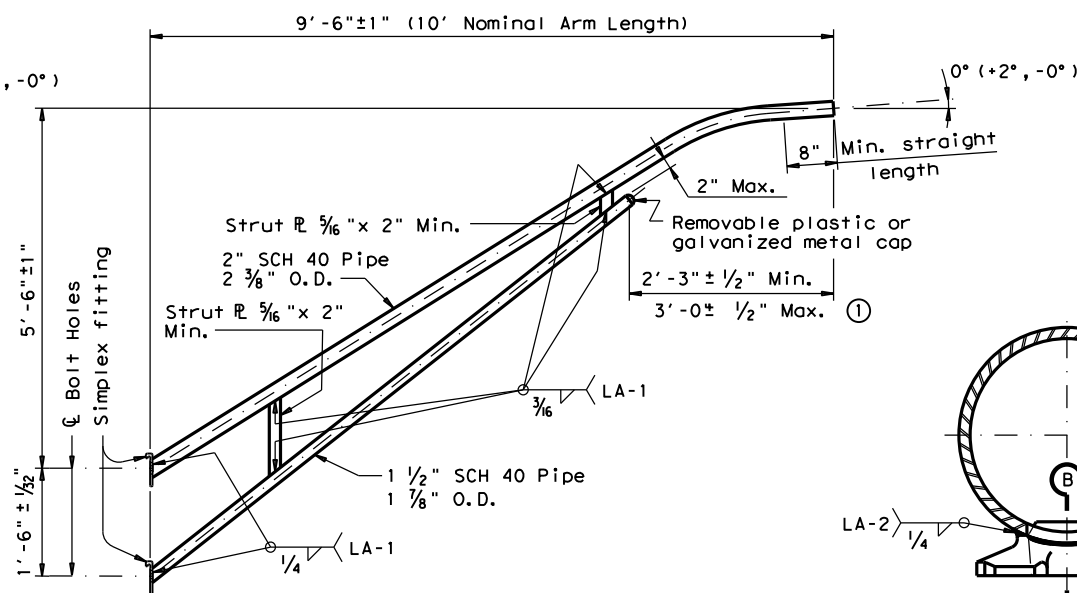

**10-FOOT LUMINAIRE ARM**

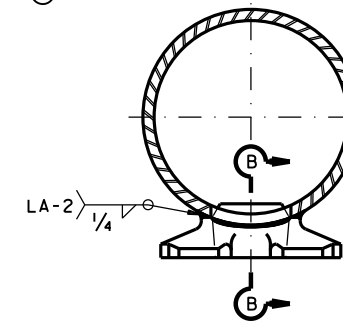

**DIRECT ATTACHMENT DETAIL**

MATERIALS	
Pole or Arm Simplex	ASTM A27 Gr. 65-35 or A148 Gr. 80-50, A576 Gr. 1021 (3), or A36 (Arm only)
Arm Pipes	ASTM A53 Gr. B, A501, A1008 HSLAS-F Gr. 50 (4), or A1011 HSLAS-F Gr. 50 (4)
Arm Strut Plates (2)	ASTM A36, A572 Gr. 50 (4), or A588
Misc.	ASTM designations as noted

- Dimensional limits are given to show acceptable variation in design. All of a Fabricator's production of a particular arm length shall have the same dimensions within specified tolerances.
- Any of the materials listed for plates may be used where the drawings do not specify a particular ASTM designation.
- A576 must be suitable for forging and also meet minimum tensile strength of 65 ksi, minimum yield of 35 ksi, and elongation in 2 inches of 22 percent.
- ASTM A572, A1008 HSLAS-F, and A1011 HSLAS-F may have higher yield strengths but shall not have less elongation than the grade indicated.

**GENERAL NOTES:**

Design conforms to 1994 AASHTO Standard Specifications for Structural Supports for Highway Signs, Luminaires, and Traffic Signals and Interim Revisions thereto. Design Wind Speed equals 90 mph plus a 1.3 gust factor. Arms are designed to support a 60 lb. luminaire having an effective projected area (actual area times drag coefficient) of 1.6 sq. ft.

Materials and fabrication shall be in accordance with Item 686, "Traffic Signal Pole Assemblies (Steel)" and with the details, dimensions, and weld procedures shown herein. Weld references call for preapproved weld procedures which the Fabricator must obtain prior to fabrication. In the absence of specified Fabricator tolerances, dimensions shall be within the tolerances generally obtainable in normal fabrication practice.

Unless otherwise noted, all parts shall be galvanized after fabrication in accordance with Item 445, "Galvanizing".

Deviation from the details and dimensions shown herein require submission of shop drawings in accordance with Item 441, "Steel Structures". Alternate designs are not acceptable.

Each pole simplex fitting shall be supplied with 2 ASTM A325 bolts and 2 lock washers of the size specified. The bolts and lock washers shall be secured to the pole with the other hardware items called for in the plans. When clamp attachment is specified, the Fabricator shall ship the clamp assembly securely attached to the pole at the location shown on the plans.

If clamp assemblies are ordered without poles, the Fabricator shall ship one upper and one lower clamp assembly together in a single package, including all nuts and washers required for the clamps and simplex fittings.

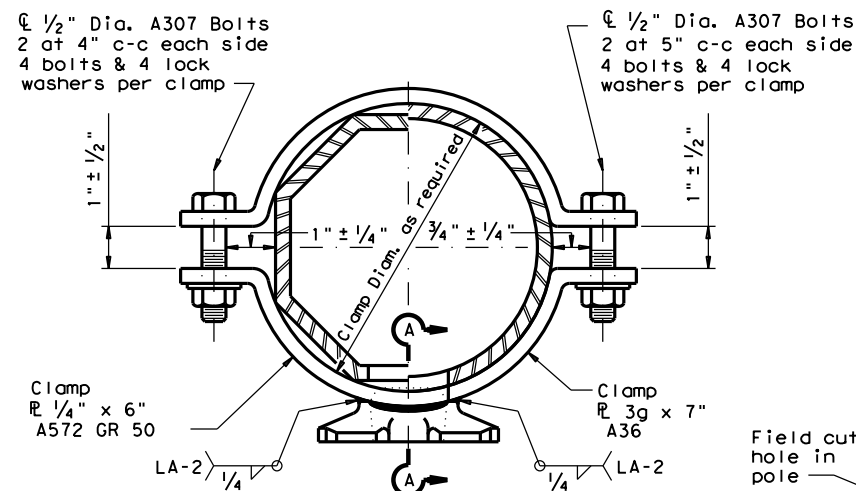

**CLAMP ATTACHMENT DETAIL NO. 1 (HALF SECTION)**      **CLAMP ATTACHMENT DETAIL NO. 2 (HALF SECTION)**

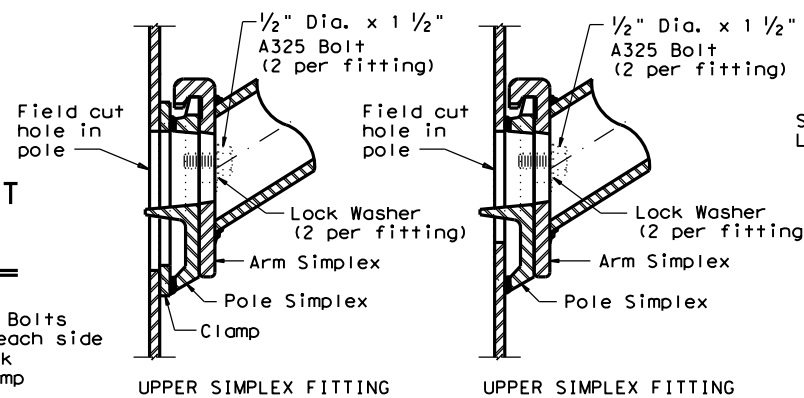

**UPPER SIMPLEX FITTING**      **UPPER SIMPLEX FITTING**

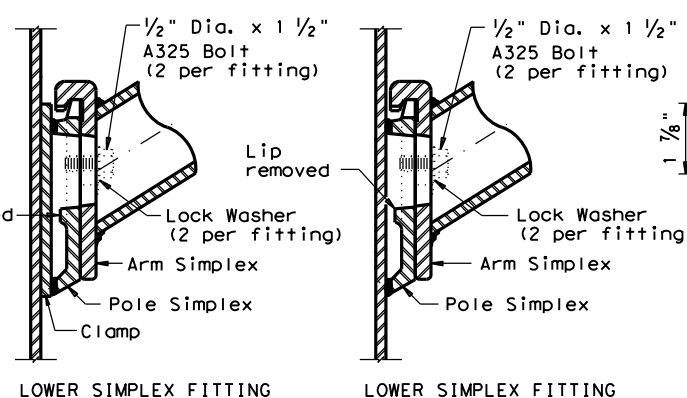

**SECTION A-A**      **SECTION B-B**

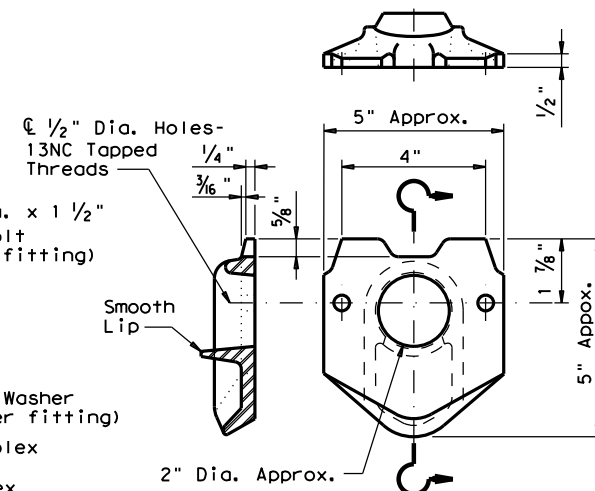

**POLE SIMPLEX DETAIL**

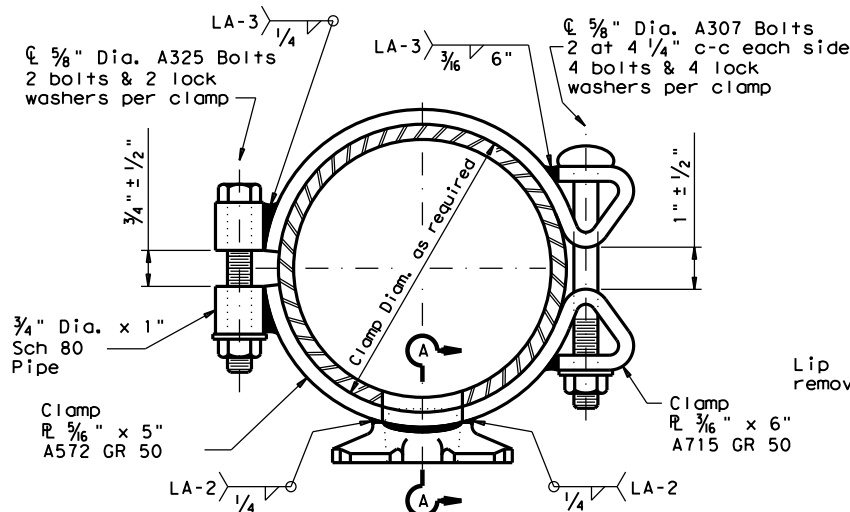

**CLAMP ATTACHMENT DETAIL NO. 3 (HALF SECTION)**      **CLAMP ATTACHMENT DETAIL NO. 4 (HALF SECTION)**

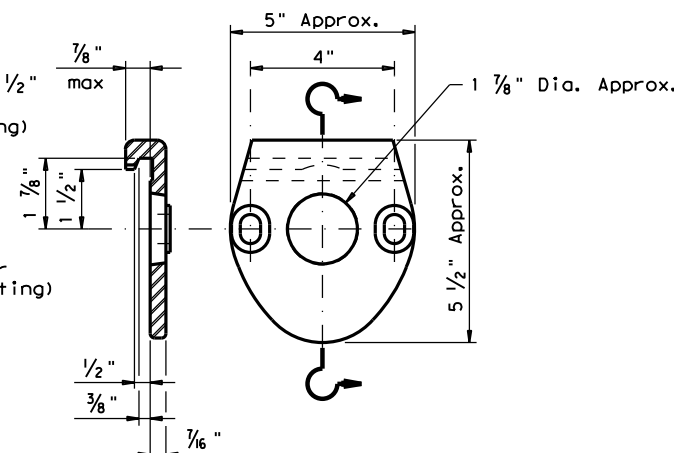

**ARM SIMPLEX DETAIL**

**Texas Department of Transportation**  
 Traffic Operations Division  
**STANDARD ASSEMBLY DRAWINGS FOR LUMINAIRE SUPPORT STRUCTURES**  
**ARM DETAILS**  
**LUM-A-12**

© TxDOT August 1995	DN: LEH	CK: JSY	DW: LTT	CK: TEB
5-96	REVISIONS	CONT	SECT	JOB
1-99		091800		392
1-12		DIST	COUNTY	SHEET NO.
		DAL	DALLAS, ETC.	64



DISCLAIMER: The use of this standard is governed by the "Texas Engineering Practice Act". No warranty of any kind is made by TxDOT for any purpose whatsoever. TxDOT assumes no responsibility for the conversion of this standard to other formats or for incorrect results or damages resulting from its use.

DATE:  
FILE:

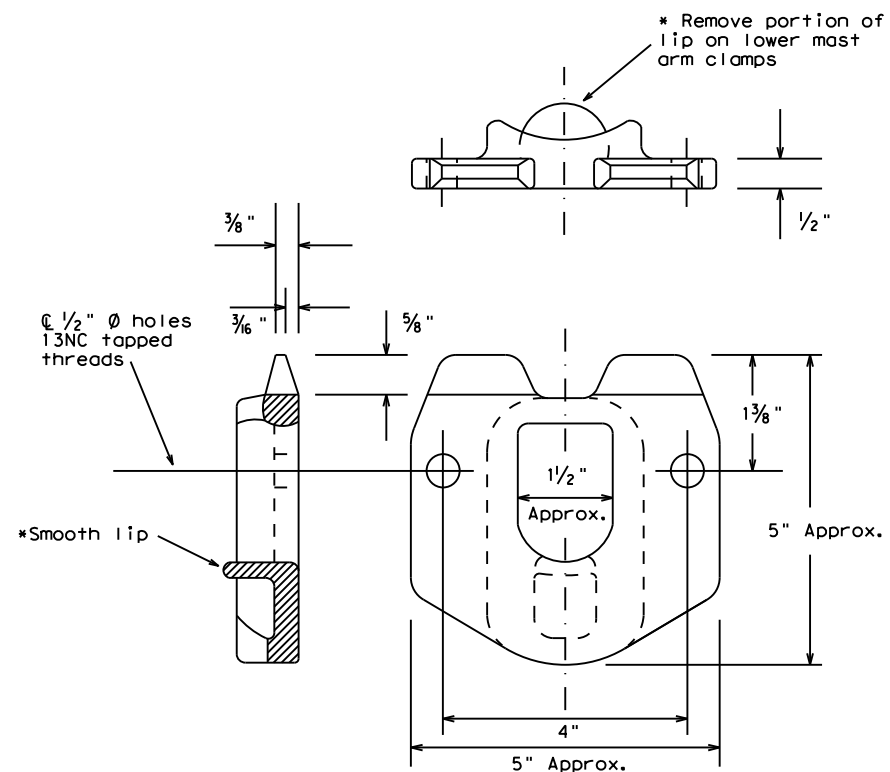

POLE SIMPLEX DETAILS

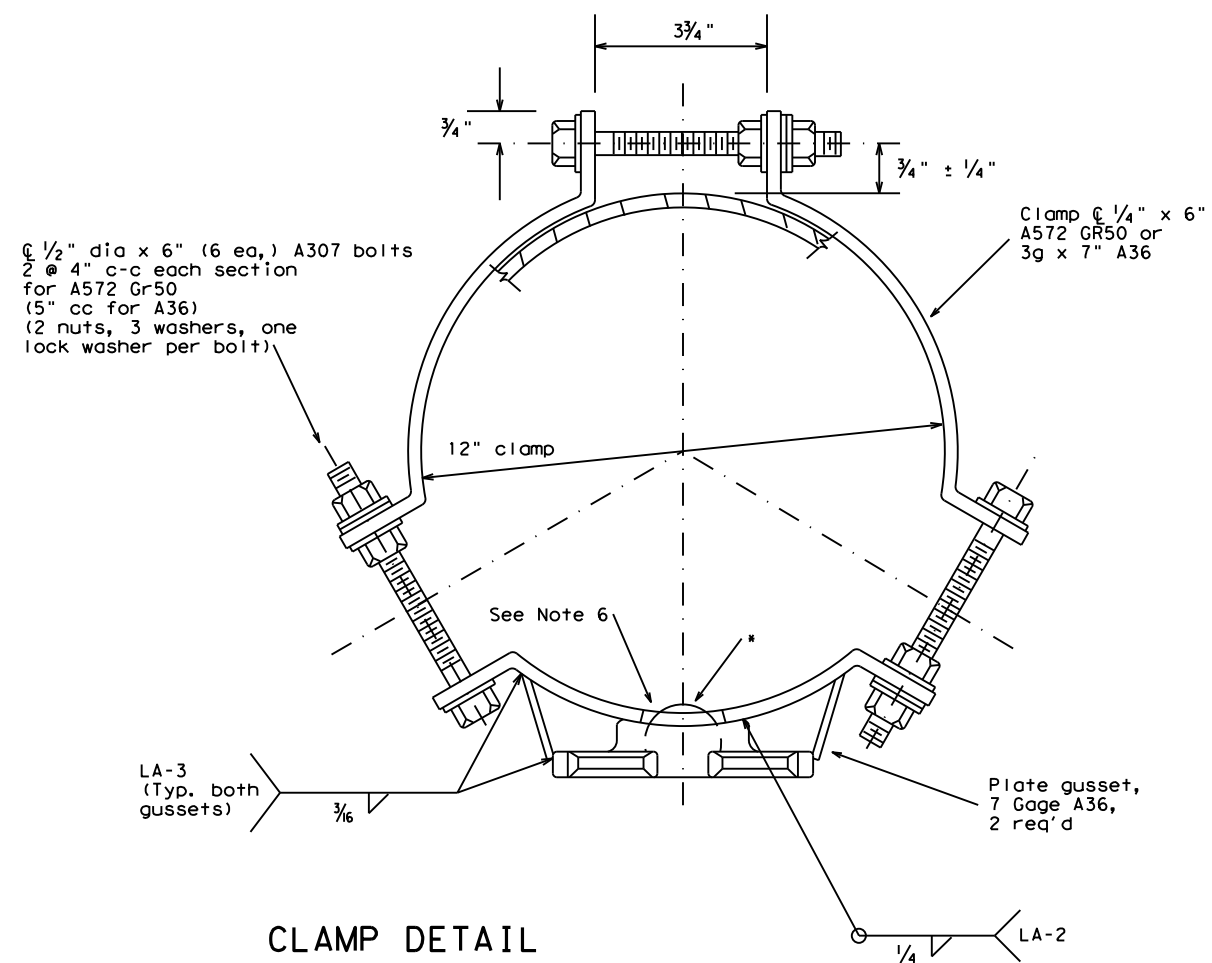

CLAMP DETAIL

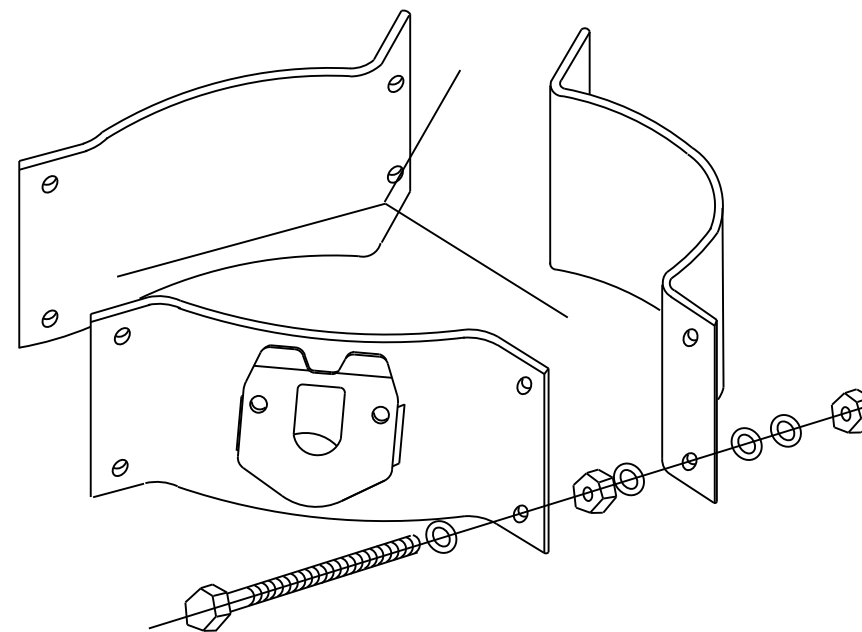

PROJECTION

For 8.9 - 12 inch diameter Signal Poles  
(Two req'd for each mast arm)

OTHER MATERIALS:

1. Pole simplex shall be ASTM A27 GR65-35 or A148 GR80-50 or A576 GR1021. ASTM A576 must be suitable for forging and also meet minimum tensile of 65ksi, minimum yield of 35ksi, and a minimum elongation of 22 percent in 2 inches.
2. Welded tabs and backplates shall be ASTM A-36 steel or better.
3. Nylon insert locknuts shall conform to ASTM A563.

GENERAL NOTES:

1. Materials and fabrication shall be in accordance with Standard Sheet "MA-C" and with the details, dimensions, and weld procedures shown herein. Weld references call for preapproved weld procedures which the Fabricator must obtain prior to fabrication. In the absence of specified fabrication tolerances, dimensions shall be within the tolerances generally obtainable in normal fabrication practice.
2. All parts shall be galvanized after fabrication in accordance with Item 445, "Galvanizing". The throat of the Simplex shall be made free of all rough or sharp edges resulting from the galvanizing process.
3. Each simplex fitting shall be supplied with 2 ASTM A325 bolts, 1/2 in. x 1 1/2 in. and 2 lock washers. The bolts and lock washers shall be secured to the clamp with the other hardware items. The Fabricator shall ship clamp assembly together in a single package, including all bolts, nuts, and washers required for the clamp and simplex fitting.
4. Design conforms to 1994 AASHTO "Standard Specifications for Structural Supports for Highway Signs, Luminaires, and Traffic Signals" and interim revisions thereto. Design Wind Speed equals 80 mph plus a 1.3 gust factor. Clamps are designed to support a 60 lb. luminaire having an effective projected area (actual area times drag coefficient) of 1.6 sq. ft., 12 ft. maximum arm length.
5. Each assembly shall consist of one upper piece simplex fitting having a smooth lip and one lower piece simplex fitting with the lip removed.
6. Approximately 2 in. diameter hole in upper mast arm clamp.

Texas Department of Transportation  
Traffic Operations Division

CLAMP ON  
FITTING ASSEMBLY FOR  
LUMINAIRE MAST ARM

CFA-12

© TxDOT	DN: KAB	CK: RES	DW: FDN	CK: CAL	
11-99 1-12	REVISIONS	CONT	SECT	JOB	HIGHWAY
		0918	00	392	VA
		DIST	COUNTY	SHEET NO.	
		DAL	DALLAS, ETC.	65	

# ROADWAY ILLUMINATION ASSEMBLY NOTES

DISCLAIMER: The use of this standard is governed by the "Texas Engineering Practice Act". No warranty of any kind is made by TxDOT for any purpose whatsoever. TxDOT assumes no responsibility for the conversion of this standard to other formats or for incorrect results or damages resulting from its use.

DATE: FILE:

1. Details apply to roadway lighting installations bid or referenced under Item 610, "Roadway Illumination Assemblies." Provide, furnish, and install all other materials not shown on the plans which may be necessary for complete and proper construction. Where manufacturers provide warranties or guarantees as a customary trade practice, furnish to the State such warranties or guarantees.
2. The locations of poles and fixtures may be shifted by the Engineer to accommodate local conditions. Install or remove poles and luminaires located near overhead electrical lines using established industry and utility safety practices and in accordance with laws governing such work. Consult with the appropriate utility company prior to beginning such work.
3. Provide new and unused materials. Ensure that all materials and installations comply with the applicable articles of the National Electrical Code (NEC), TxDOT standards and specifications, National Electrical Manufacturers Association (NEMA), and are listed by Underwriters Laboratories (UL) or a Nationally Recognized Testing Lab (NRTL). NRTLs such as Canadian Standard Association, Intertek Testing Services NA Inc., or FM Approvals LLC can be considered equivalent to UL. Faulty fabrication or poor workmanship in any material, equipment, or installation is justification for rejection.
4. Provide Roadway Illumination Light Fixtures as per TxDOT Departmental Material Specification (DMS) 11010, Item 610, and as shown on the Material Producers List (MPL) for Roadway Illumination and Electrical Supplies.
5. Fabricate steel roadway illumination poles in accordance with Roadway Illumination Poles (RIP) standards and Item 610. Poles fabricated according to RIP standards do not require shop drawing submittals.
  - a. Alternate designs to RIP standards or the use of aluminum to fabricate poles will require the submission of shop drawings electronically. For instructions on submitting shop drawings electronically see "Guide to Electronic Shop Drawing Submittal" on the TxDOT web site.
  - b. Limitations on use of the RIP standard: The RIP standard details were developed for installations in locations where the 3-second gust basic maximum wind speed is 110 mph, and where the elevation of the base of the pole is less than (i.e. not more than) 25' above the elevation of the surrounding terrain, in accordance with the "AASHTO Standard Specifications for Structural Supports for Highway Signs, Luminaires and Traffic Signals," 6th Edition (2013) of the AASHTO Design Specifications. For poles to be installed in regions where the maximum basic wind speed exceeds 110 mph or to be mounted more than 25' above the surrounding terrain, provide poles meeting the following requirements:
    - i. Submittals. Following the electronic shop drawing submittal process (see Guide to Electronic Shop Drawing Submittal on the TxDOT web site), submit to the Engineer for approval fabrication drawings and calculations for the poles, sealed by a Texas licensed professional engineer (P.E.).
    - ii. Luminaire Structural Support Requirements. Provide light poles, arms, and anchor bolt assemblies with a 25 year design life to safely resist dead loads, ice loads and the required basic wind speeds at the location of installation in accordance with the 6th edition (2013) of the AASHTO Design Specifications. For transformer base poles, include transformer base and connecting hardware in calculations and shop drawing submittals. Structurally test all transformer bases to resist the theoretical plastic moment capacity of the pole. Submit certification of the plastic moment load test and FHWA breakaway requirement test of the model of base being furnished with the shop drawings. Show breakaway base model number, manufacturer's name, and logo on shop drawings. Include on manufacturer's shop drawings the ASTM designations for all materials to be used.
6. For both transformer and shoe-base type illumination poles, provide and install double-pole breakaway fuse holders as specified by DMS-11040. Breakaway fuse holders are listed on the MPL for Roadway Illumination and Electrical Supplies under Items 610 & 620. Provide 10 amp time delay fuses for breakaway connectors in light poles, or inside the light fixture for underpass luminaires. In each pole, connect luminaires to the breakaway connector with continuous stranded 12 AWG copper conductors as listed on the MPL. Bond all equipment grounding conductors together and to the ground lug in the transformer base or hand hole.
7. Tighten anchor bolts for shoe base, concrete traffic barrier base, and bridge mount roadway illumination poles, in accordance with Item 449.
8. Install T-Base with following procedure:
  - a. Anchor Bolt Tightening.
    - i. Coat the threads of the anchor bolts with electrically conductive lubricant.
    - ii. Place the T-base over the anchor bolts. Foundation must be level and flat. The maximum permissible gap under any one corner of the t-base is 1/8" before nuts are tightened.
    - iii. Coat the bearing surfaces of the nuts and washers with electrically conductive lubricant. Install (1) 1/2" hold down washer, (1) lock washer, and (1) nut on each anchor bolt. Turn the nuts onto the bolts so that each is hand-tight against the washer.
    - iv. Using a torque wrench, tighten each nut to 150 ft-lb. Uniform contact is required between the foundation and the T-base in the corner regions of the T-base, and all corner gaps must be closed after applying torque. If a gap still exists after torquing to 150 ft-lbs, continue torquing each bolt incrementally until gap is closed or maximum allowable torque of 250 ft. pound is reached, whichever comes first. If 250 ft-lbs is not enough to close the gap the foundation must be leveled. Gaps along the straight sides of the T-bases and the foundation are permissible. Ensure that no high point of contact occurs between the straight sides of the T-base and the foundation.
    - v. Check top of T-base for level. If not level then foundation must be leveled.
  - b. Top Bolt Procedure
    - i. Erect pole over T-base with crane. Coat bolts, nuts, washers, and lock washers with electrically conductive lubricant.

- ii. Install bolts and 1/2" connecting washers from the inside of the T-base, thread up through the pole base. Install flat washers, lock washers and nuts snug tight according to Item 447, "Structural Bolting."
  - iii. Tighten each nut to 150 ft-lb. using a torque wrench.
- c. Level and Plumb
- i. Ensure pole is plumb and mast arm is perpendicular to the roadway according to plans to within 5 degrees.
9. Construct luminaire pole foundations in accordance with Item 416, "Drilled Shaft Foundations," and TxDOT standard sheet RID(2).
  10. Provide and install underpass luminaires in accordance with Item 610, DMS-11010, and TxDOT standard sheet RID(3). Typical luminaire size for underpass luminaires is 150W HPS or 150W EQ LED.
  11. Mount luminaires on arms level as shown by the luminaire level indicator.
  12. Orient luminaires perpendicular to the roadway intended to be lit unless otherwise shown on the plans.

## Wiring Diagram Notes:

- ① Use 1/2 in. -13 UNC threaded, copper or tin-plated copper, pole bonding connector, sized appropriately for conductors, bonded to T-base, or use ground lug in handhole as available.
- ② Use pre-qualified two-pole breakaway connectors for all luminaire pole installations. For luminaires fed by a circuit with a neutral conductor, use double pole breakaway connectors with the neutral side unfused and marked white.
- ③ Split Bolt or other connector.

## Decorative LED Lighting Notes:

1. LED Drivers in Remote Outdoor enclosures (for drivers that do not include an enclosure as part of a factory assembly):
  - a. Provide NEMA 3R outdoor enclosure or as approved.
  - b. Install enclosure at least 12" above ground or other horizontal surface. Mount vertically or on ceiling, and avoid direct sun where possible.
  - c. Install drivers with at least 2 inches of space from enclosure walls.
  - d. For multiple drivers in an enclosure, provide at least 4 inches side to side and 1 inch end to end from other drivers or electronic equipment
  - e. For drivers mounted on back wall of enclosure, mount enclosure on 1 5/8" strut or other standoff to dissipate heat, or mount driver to side of the enclosure or to the metal cover.
  - f. Provide remote drivers with a maximum of 100 watts
  - g. Provide drivers with documentation of 100,000 hr lifetime at Tcase of 65C or higher.

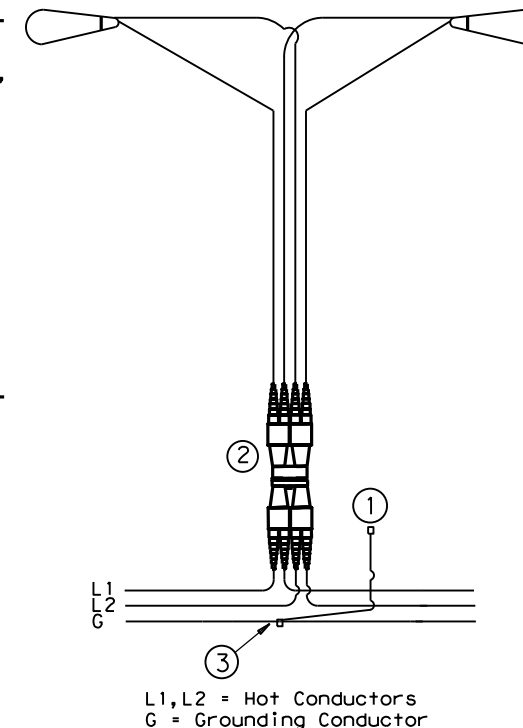

## TYPICAL WIRING DIAGRAM

LUMINAIRES SERVED AT 480V ON 240/480 VOLT SERVICE OR LUMINAIRES SERVED AT 240V FOR 120/240 VOLT SERVICE.

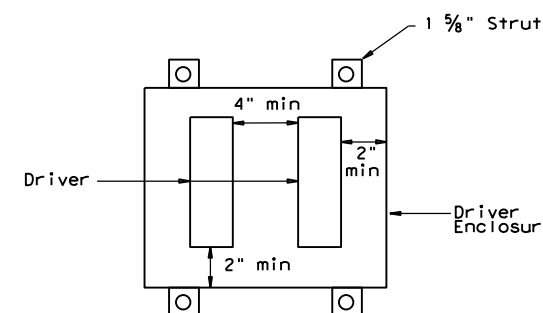

Driver Spacing In Remote Enclosure

		Traffic Safety Division Standard	
<h1>ROADWAY ILLUMINATION DETAILS</h1> <h2>RID(1)-20</h2>			
FILE: rid1-20.dgn	DN:	CK:	DW:
© TxDOT January 2007	CONT	SECT	JOB
REVISIONS	0918	00	392
7-17	DIST	COUNTY	SHEET NO.
12-20	DAL	DALLAS, ETC.	66

DISCLAIMER: The use of this standard is governed by the "Texas Engineering Practice Act". No warranty of any kind is made by TxDOT for any purpose whatsoever. TxDOT assumes no responsibility for the conversion of this standard to other formats or for incorrect results or damages resulting from its use.

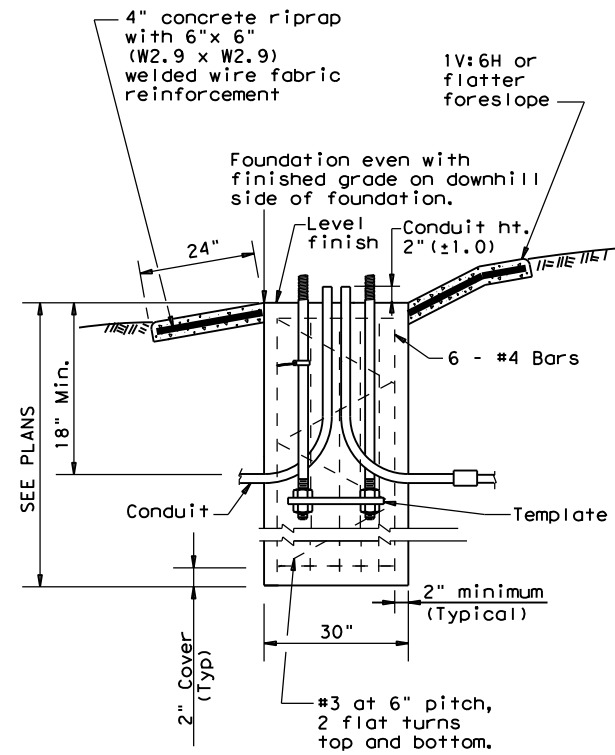

**SECTION A-A**  
SHOWING SLOPED GRADE

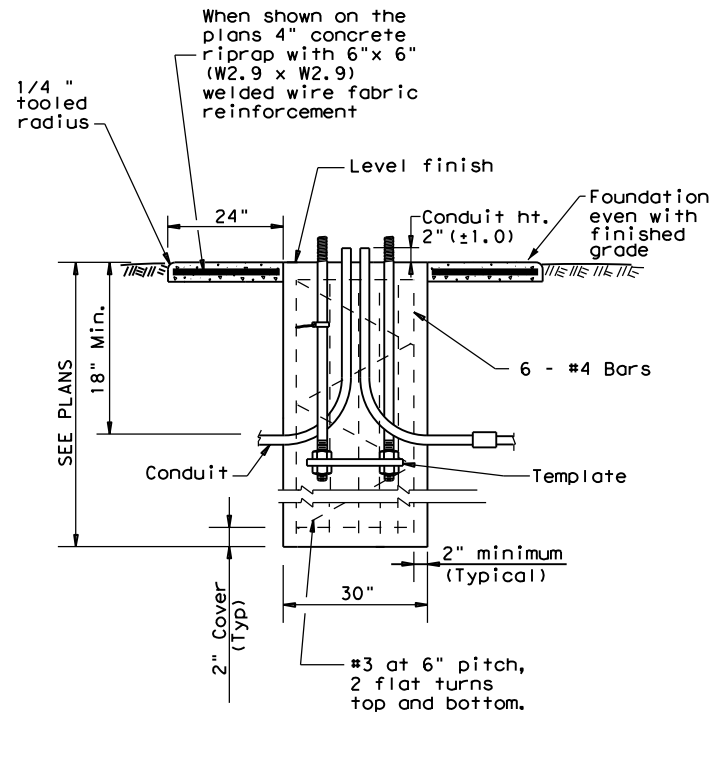

**SECTION A-A**  
SHOWING CONSTANT GRADE

**TABLE 1**

**ANCHOR BOLTS**

POLE MOUNTING HEIGHT	BOLT CIRCLE		ANCHOR BOLT SIZE
	Shoe Base	T-Base	
<40 ft.	13 in.	14 in.	1 in. x 30 in.
40-50 ft.	15 in.	17 1/4 in.	1 1/4 in. x 30 in.

**TABLE 2**

**RECOMMENDED FOUNDATION LENGTHS**  
(See note 1)

MOUNTING HEIGHT	TEXAS CONE PENETROMETER N Blows/ft		
	10	15	40
≤20 ft.	6'	6'	6'
>20 ft. to 30 ft.	8'	6'	6'
>30 ft. to 40 ft.	8'	8'	6'
>40 ft. to 50 ft.	10'	8'	6'

**TABLE 3**

**PAY QUANTITY OF RIPRAP PER FOUNDATION**  
(Install only when shown on the plans)

Foundation Diameter	RIPRAP DIAMETER	RIPRAP (CONC) (CL B)
30 in.	78 in.	0.35 CY

**GENERAL NOTES:**

1. "Recommended Foundation Lengths" table is for information purposes only. Foundation lengths shall be as shown on the plans, or as directed by the Engineer. Foundations will be paid for under Item 416, "Drilled Shaft Foundations," unless otherwise shown on the plans.
2. Erect roadway illumination assembly poles plumb and true. Form and level the top 6" of the foundation so the pole will be plumb. Use leveling nuts to plumb shoe base poles. Do not use shims or leveling nuts under transformer bases. Do not grout between baseplate and the foundation.
3. Ensure Class 2A and 2B fit for anchor bolts and nuts. Tap and chase nuts after galvanizing. Anchor bolt body with rolled threads need not be full size.
4. Use appropriate class of concrete as specified in Items 416 and 432. Concrete for riprap may be upgraded to Class C at no extra cost to the Department.
5. Place riprap around the foundation when called for elsewhere in the plans. Riprap will be paid for under Item 432.
6. Locate breakaway roadway illumination assemblies as shown in the placement table, unless otherwise dimensioned on the plans. Protect non-breakaway illumination assemblies from vehicular impact (i.e. 2.5 ft. behind guard rail or mounted on traffic barrier), or located outside the clear zone, except that 2.5 ft. from curb face is minimum desired for light poles on city streets, 45 mph or less. See Roadway Design Manual for further information.
7. Use 4 hold down and 4 connecting washers on transformer base poles as recommended by the manufacturer and supplied with base.
8. Install a minimum of 2 conduits in each foundation. See lighting layout sheets for locations of foundations with more than 2 conduits. Cap unused conduits in foundations on both ends.
9. Conduit location in foundations is critical for breakaway devices. Place conduits 2 in. apart on centerline as shown.
10. Bond anchor bolt to rebar cage with #6 bare stranded copper conductor. Use listed mechanical connectors rated for embedment in concrete. The bonded steel in the foundation creates a concrete encased grounding electrode which replaces the ground rod.
11. Grade earthwork around T-base foundations even with the finished grade as shown in Section A-A to ensure proper function of the breakaway device. Use riprap on T-base foundations that are located on sloped grades, and as shown on the plans for level grades.

**TABLE 4**

**BREAKAWAY POLE PLACEMENT (See note 6)**

ROADWAY FUNCTIONAL CLASSIFICATION	** POLE OFFSET (DISTANCE TO FACE OF TRANSFORMER BASE)
Freeway Mainlanes (roadway with full control of access)	15 ft. (minimum and typical) from lane edge
All curbed, 45 mph or less design speed	2.5 ft. minimum (15 ft. desirable) from curb face
All others	10 ft. minimum*(15 ft. desirable) from lane edge

\* or as close to ROW line as is practical

\*\* provide 2/5 of the luminaire mounting height behind the pole for "falling area" to prevent encroachment on the other travel lanes. See design guidelines.

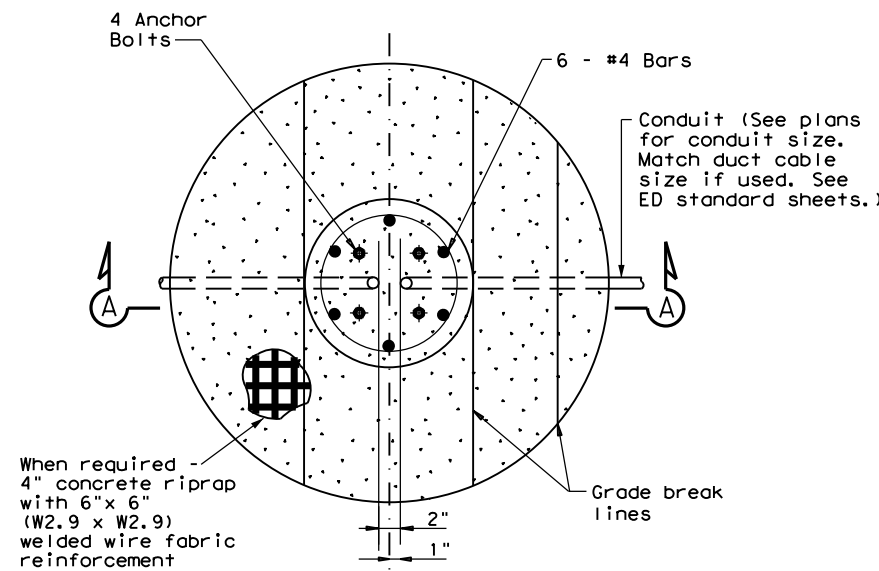

**FOUNDATION DETAIL**

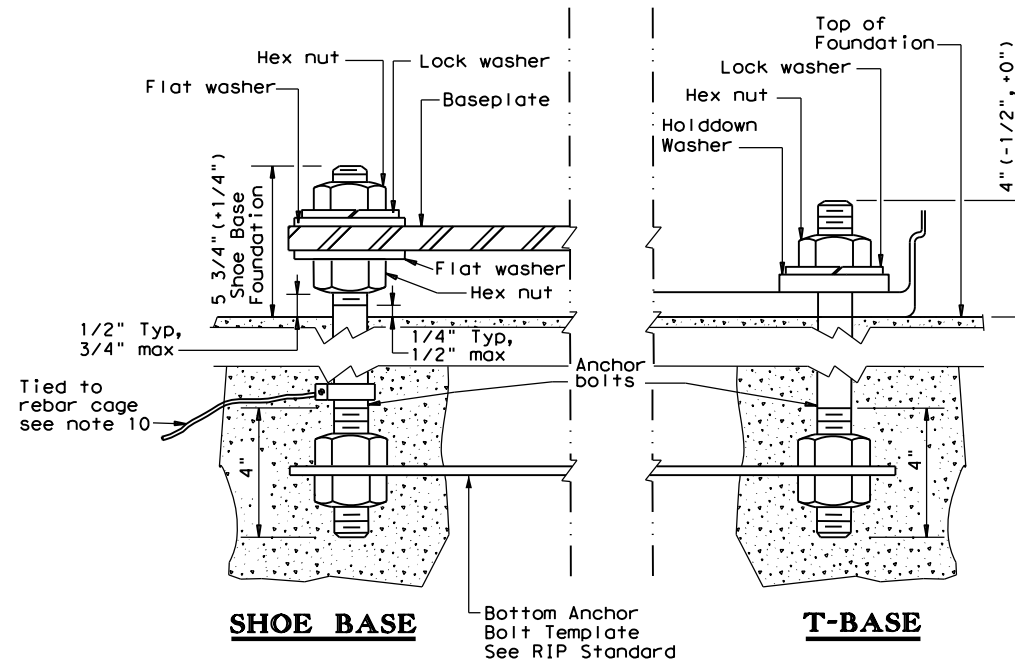

**ANCHOR BOLT DETAIL**

**ROADWAY ILLUMINATION DETAILS**  
(RDWY ILLUM FOUNDATIONS)  
**RID(2)-20**

FILE: rid2-20.dgn	DN:	CK:	DW:	CK:
© TxDOT January 2007	CONT	SECT	JOB	HIGHWAY
REVISIONS	0918	00	392	VA
1-11	DIST	COUNTY	SHEET NO.	
7-17	DAL	DALLAS, ETC.	67	
12-20				

DATE:  
FILE:

DISCLAIMER: The use of this standard is governed by the "Texas Engineering Practice Act". No warranty of any kind is made by TxDOT for any purpose whatsoever. TxDOT assumes no responsibility for the conversion of this standard to other formats or for incorrect results or damages resulting from its use.

DATE: FILE:

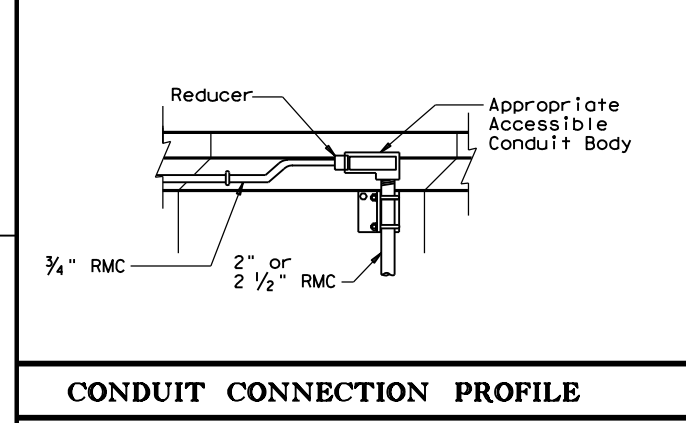
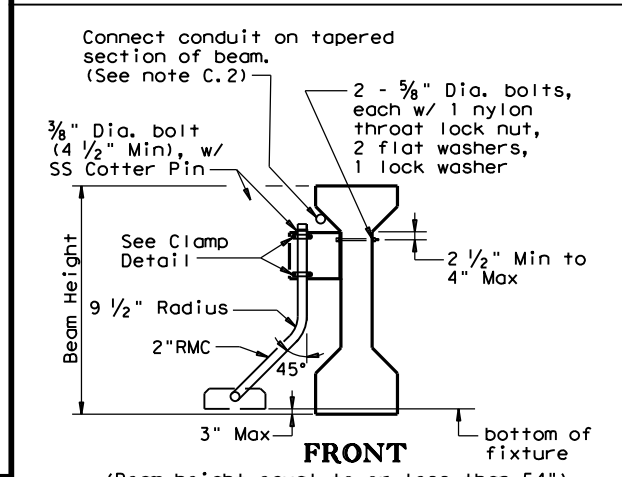
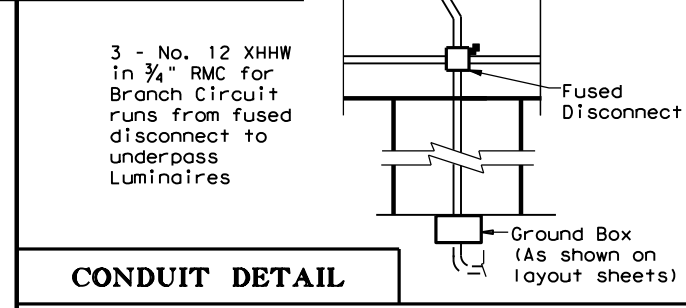
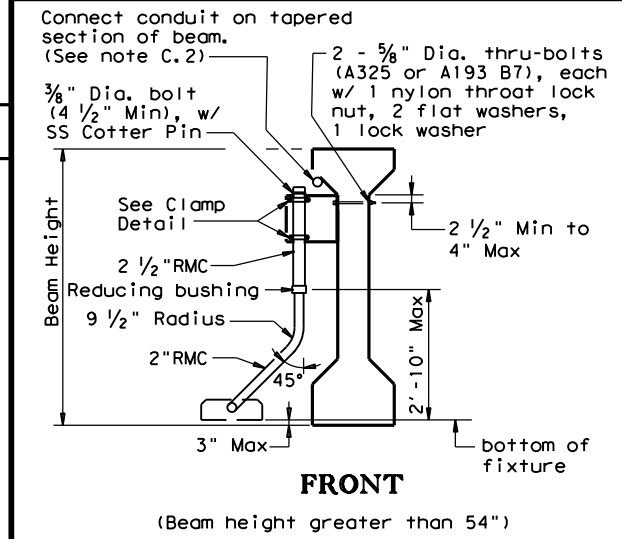
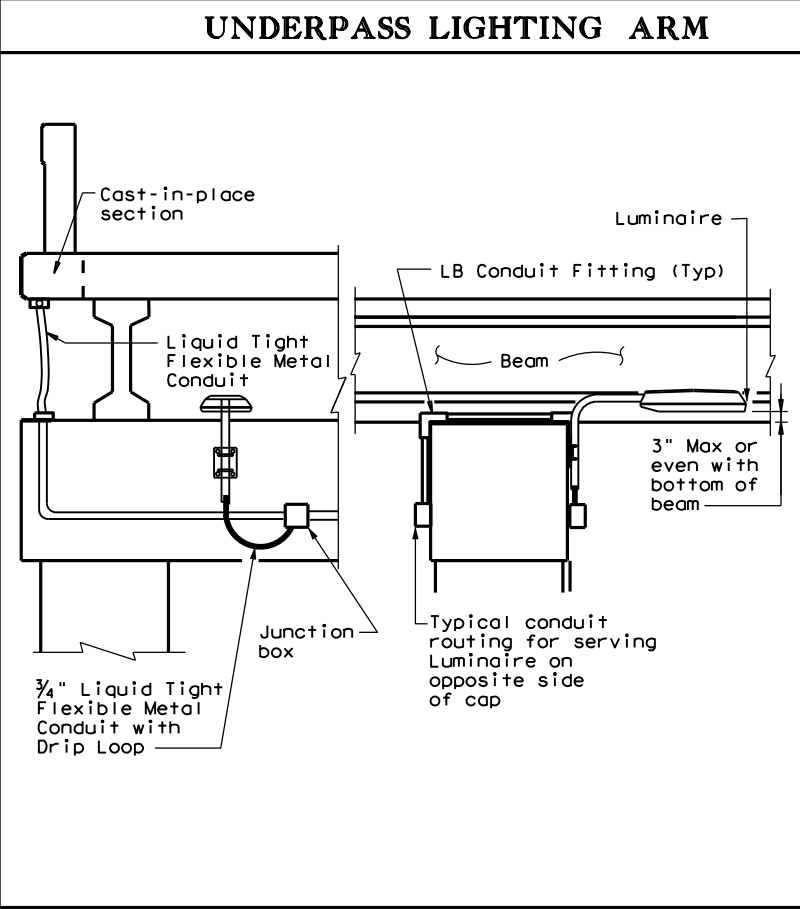
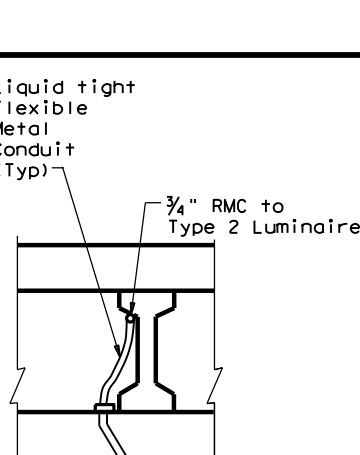
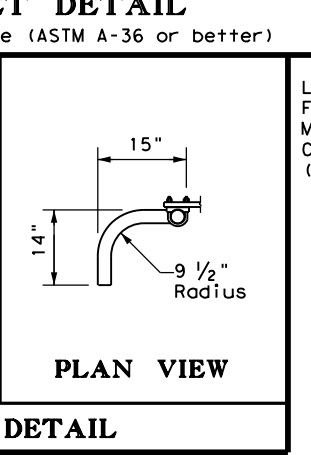
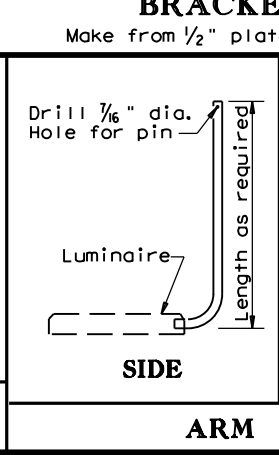
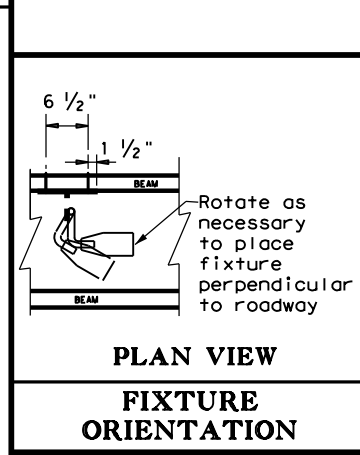
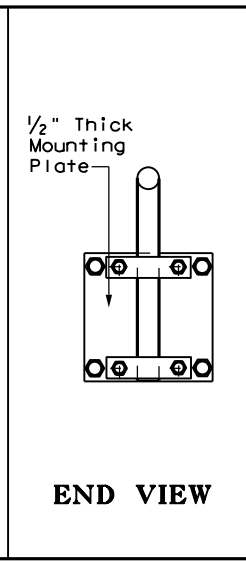
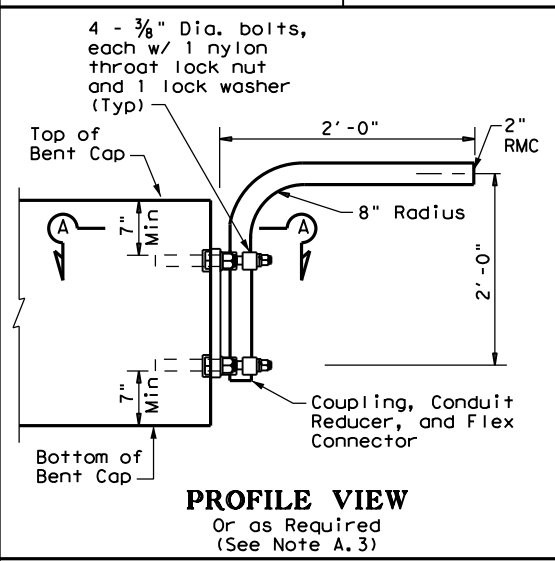
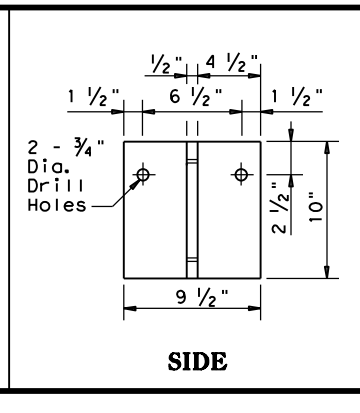
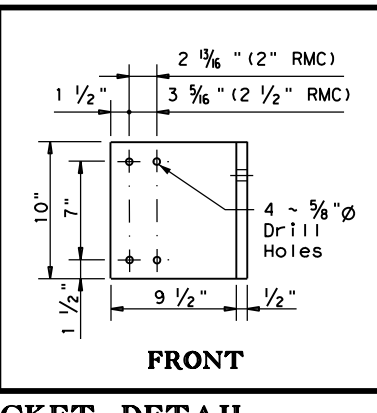
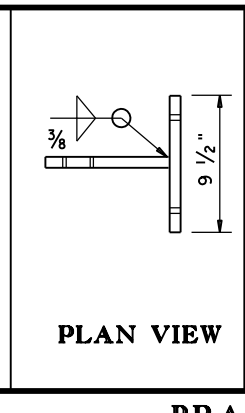
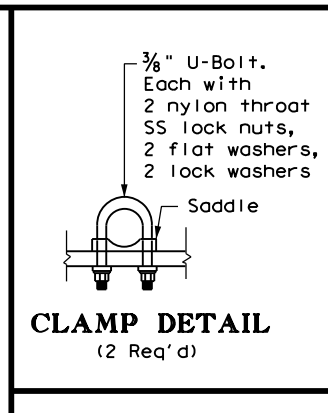
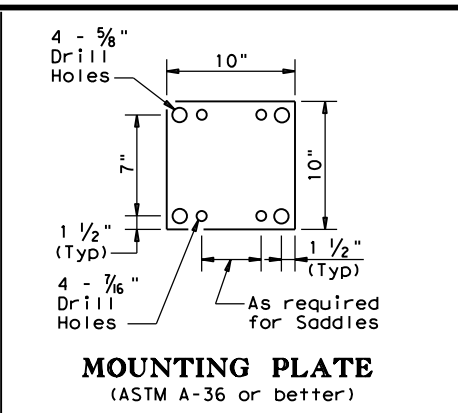
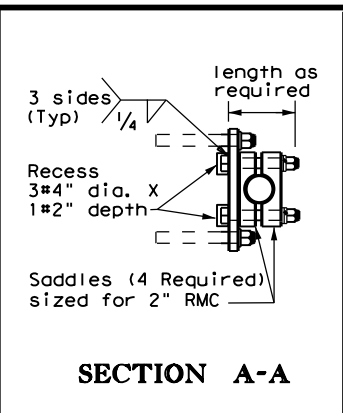

**IN RD IL AM (U/P) (TY 1)**  
 If bridge has pre-cast panels under deck, run circuit under deck edge.  
**UNDERPASS LIGHTING TYPE 1**

**IN RD IL AM (U/P) (TY 2)**  
**UNDERPASS LIGHTING TYPE 2**

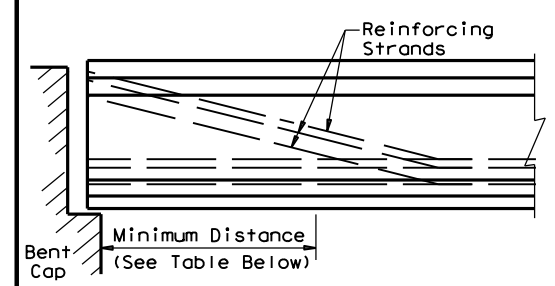

SPAN LENGTH	MINIMUM DISTANCE
≤ 50'	10'-0"
50' - 70'	15'-0"
70' - 90'	20'-0"
> 90'	25'-0"

**LOCATION OF UNDERPASS LIGHT MOUNTING BRACKET**  
**UNDERPASS LIGHTING TYPE 2**

**GENERAL NOTES:**

- A. ALL 150 watt HPS and 150 watt equivalent LED Luminaires**
- Luminaire locations, conduit and conductor sizes and routing are typical and diagrammatic only. See project layout sheets for specific details.
  - Conduit will be paid for under Item 618, "Conduit" and conductors will be paid for under Item 620, "Electrical Conductors," unless otherwise shown on the plans.
  - Adjust conduit in saddles to place fixture height and orientation as required. See fixture orientation detail and plans. Where practicable, place luminaires so the bottom of luminaire is above the bottom of the beam, maximum of 3 in. (See detail UNDERPASS LIGHTING ARM TYPE 2)
  - Except as noted, galvanize all structural steel and exposed bolts, nuts, and washers in accordance with Item 445 "Galvanizing".
  - Fabrication of brackets and support arms will not be paid for directly but is subsidiary to Item 610, "Roadway Illumination Assemblies."
  - Install a heavy duty NEMA 3R fused disconnect or breaker enclosure rated at 30 amps and 480 volts to switch underpass luminaires as shown on plans, with at least one per bridge circuit. Install 20 amp time-delay fuses or inverse-time circuit breakers. Mount disconnect or breaker enclosure 10 ft. (min) above grade on columns or bent caps as approved by the Department. Modify disconnect to allow padlocking in the "ON" and "OFF" positions. Padlocks and disconnect switches or circuit breakers for underpass fixtures will not be paid for directly but are subsidiary to the various bid items of the contract.
  - Conduit on columns, caps, and slab is shown surface mounted. For new columns and caps, embed PVC conduit in concrete. Bond and ground metal junction boxes and conduit.
- B. TYPE 1**
- Provide 2 in. rigid metal conduit (2.375" O.D., 0.146" wall) for Type 1 arm shaft.
  - Use 3/8 in. stainless steel bolt or stud non-epoxy type expansion anchors for concrete for Type 1 mounting. Except as noted, provide an allowable 2650 lbs minimum pull-out force (after consideration of adjustment factors for edge distance and bolt spacing) for each anchor. Install each anchor to the embedment depth recommended by the manufacturer.
  - Attach conduit to plate with 4 saddles, four - 3/8 in. diameter bolts, nylon throat lock nuts, and lock washers.
- C. TYPE 2**
- Provide 2 in. rigid metal conduit (2.375" O.D., 0.146" wall) or provide a combination of 2 1/2 in. (2.875" O.D., 0.193" wall) and 2 in. (2.375" O.D., 0.146" wall) rigid metal conduits with a reducing bushing as beam height stipulated for Type 2 arm shaft. Field cutting and threading will be permitted. Paint cut and threaded areas with zinc rich paint after conduit is connected to adjacent fitting.
  - Connecting conduit may be strapped to tapered section only of precast beams as shown. Anchor as approved by the Engineer. Maximum anchor depth is 1 in.
  - Indiscriminate drilling into precast concrete beams may result in reduced beam strength. Use drilling location and method as directed by the Engineer. See Location of Underpass Lighting Mounting Bracket detail. The locations shown in the table are such that reinforcing strands will not be damaged.

Texas Department of Transportation  
 Traffic Safety Division Standard

## ROADWAY ILLUMINATION DETAILS (UNDERPASS LIGHT FIXTURES)

### RID(3)-20

FILE: rid3-20.dgn	DN: TxDOT	CK: TxDOT	DW: TxDOT	CR: TxDOT
© TxDOT May 2013	CONT: 0918	SECT: 00	JOB: 392	HIGHWAY: VA
REVISIONS: 2-14, 7-17, 12-20	DIST: DAL	COUNTY: DALLAS, ETC.	SHEET NO.: 68	



DISCLAIMER: The use of this standard is governed by the "Texas Engineering Practice Act". No warranty of any kind is made by TxDOT for any purpose whatsoever. TxDOT assumes no responsibility for the conversion of this standard to other formats or for incorrect results or damages resulting from its use.

DATE: FILE:

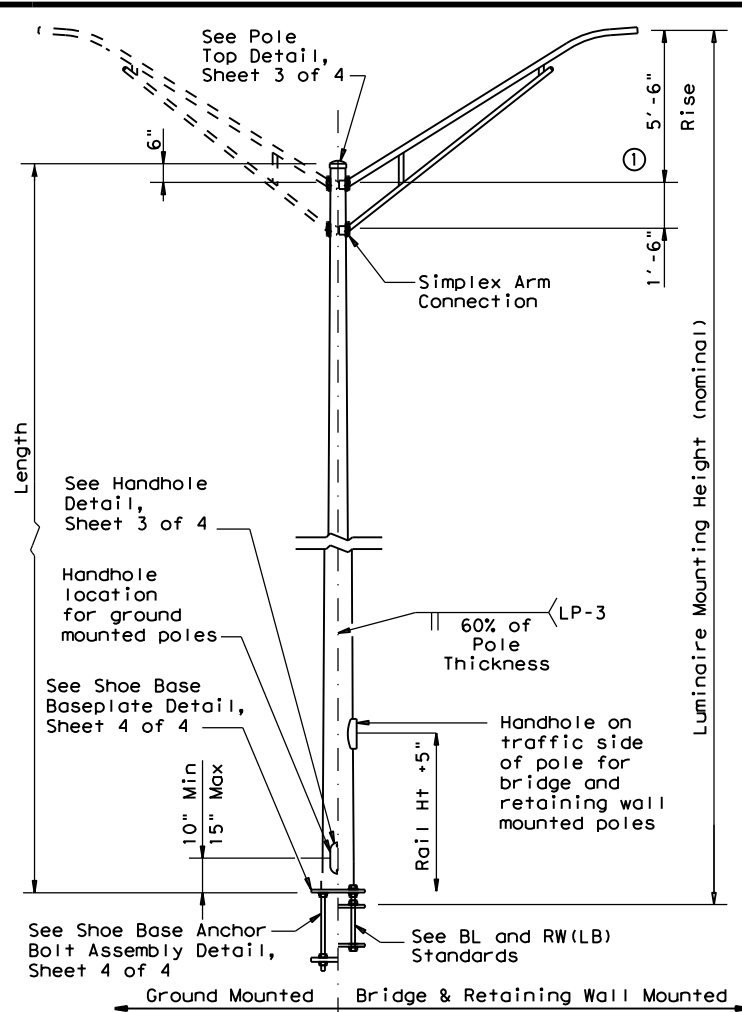

**SHOE BASE POLE**

SHOE BASE POLE					
Luminaire Mounting Height (Nominal) (ft)	Base Diameter (in)	Top Diameter (in)	Length (ft)	Pole Thickness (in)	Design Moment (K-ft)
20.00	7.00	4.90	15.00	0.1196	7.1
30.00	7.50	4.00	25.00	0.1196	13.2
31.00-39.00	8.00	4.36-3.24	26.00-34.00	0.1196	20.7
40.00	8.50	3.60	35.00	0.1196	20.7
50.00	10.50	4.20	45.00	0.1196	30.3

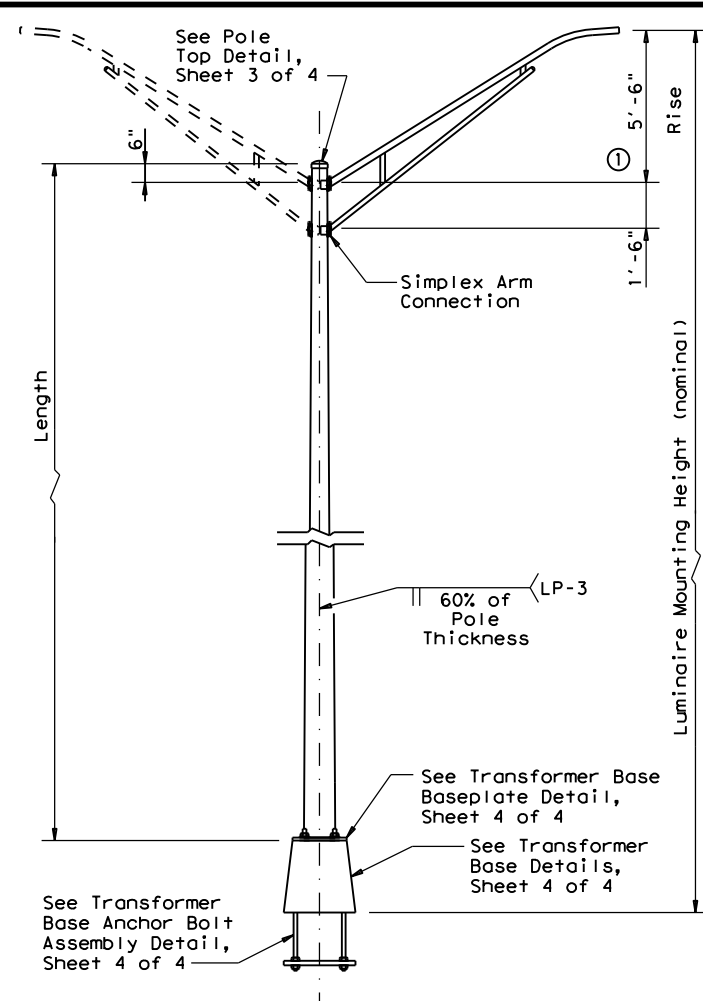

**TRANSFORMER BASE POLE**

TRANSFORMER BASE POLE					
Luminaire Mounting Height (Nominal) (ft)	Base Diameter (in)	Top Diameter (in)	Length (ft)	Pole Thickness (in)	Design Moment (K-ft)
20.00	7.00	5.11	13.50	0.1196	7.1
30.00	7.50	4.21	23.50	0.1196	13.2
31.00-39.00	8.00	4.57-3.45	24.50-32.50	0.1196	20.7
40.00	8.50	3.81	33.50	0.1196	20.7
50.00	10.00	3.91	43.50	0.1196	30.3

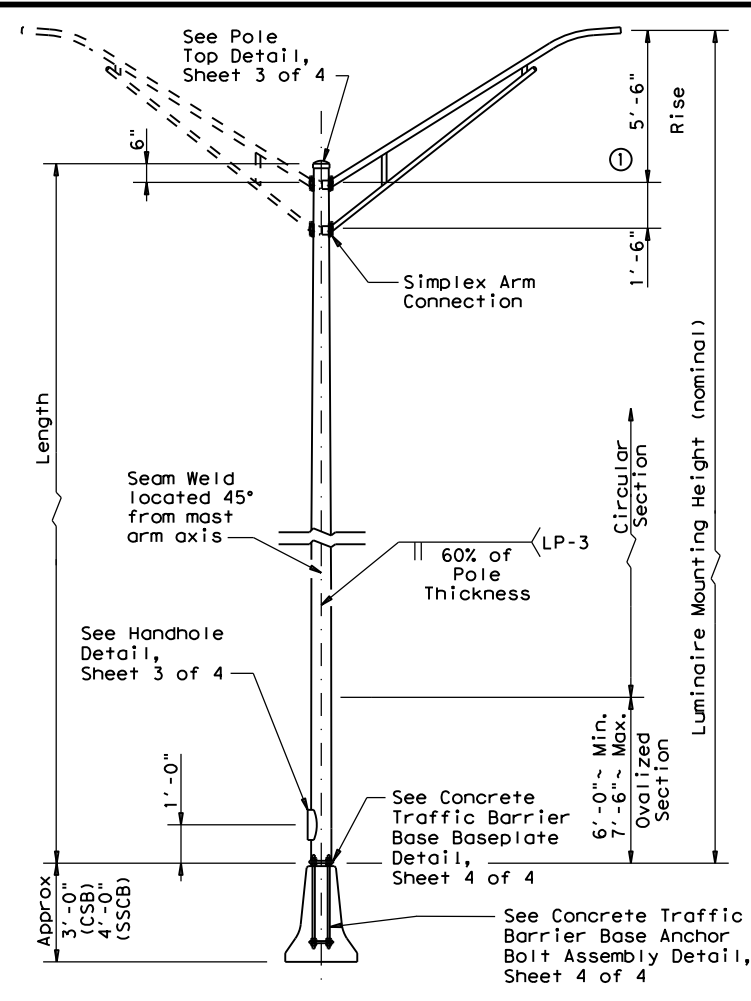

**CONCRETE TRAFFIC BARRIER BASE POLE**

CONCRETE TRAFFIC BARRIER BASE POLE (CSB/SSCB)						
Luminaire Mounting Height (Nominal) (ft)	Base Diameter (in)	Top Diameter (in)	Length (ft)	Pole Thickness (in)	Design Moment (K-ft)	
					About C of Rail	Perp. to Rail
28.00	9.00	5.78	23.00	0.1196	10.3	13.2
38.00	9.00	4.38	33.00	0.1196	16.6	20.8
48.00	10.50	4.48	43.00	0.1345	25.1	30.5

**MATERIAL DATA**

COMPONENT	ASTM DESIGNATION	MIN. YIELD (ksi)
Pole Shaft (0.14"/ft. Taper)	A572 Gr 50, A595 Gr A, A1011 HSLAS Gr 50 Cl 2 ③, or A1008 HSLAS Gr 50 Cl 2	50
Base Plate and Handhole Frame	A572 Gr.50, or A36	36
T-Base Connecting Bolts	F3125 Gr A325	92
Anchor Bolts	F1554 Gr 55, A193-B7 or A321	55 105
Anchor Bolt Templates	A36	36
Heavy Hex (H.H.) Nuts	A194 Gr 2H, or A563 Gr DH	
Flat Washers	F436	

**NOTES:**

- ① 2'-6" rise for 4 ft. luminaire arms.
- ② Before ovalized as shown on Concrete Traffic Barrier Base Baseplate details, Sheet 4 of 4.
- ③ A1011 SS Gr 50 may be used instead of HSLAS, provided the material meets the elongation requirements for HSLAS.

**POLE ASSEMBLY FABRICATION TOLERANCES TABLE**

DIMENSION	TOLERANCE
Shaft length	+1"
I.D. of outside piece of slip fitting pieces	+1/8", -1/16"
O.D. of inside piece of slip fitting pieces	+1/32", -1/8"
Shaft diameter: other	+3/16"
Out of "round"	1/4"
Straightness of shaft	±1/4" in 10 ft
Twist in multi-sided shaft	4° in 50 ft
Perpendicular to baseplate	1/8" in 24"
Pole centered on baseplate	±1/4"
Location of Attachments	±1/4"
Bolt hole spacing	±1/16"

**GENERAL NOTES:**

1. Designs conform to AASHTO Standard Specifications for Structural Supports for Highway Signs, Luminares, and Traffic Signals, 6th Edition (2013) and Interim Revisions thereto. Design 3-Second Gust Wind Speed equals 110 mph with a 1.14 gust factor. A wind importance factor of 0.80 is applied to adjust the wind speed to a 25 year recurrence interval. Design moments listed in tables assume base of pole is 25' above natural ground level.
2. Structures are designed to support two 12' luminaire mast arms and luminaires. Mast arms are designed to support a 60-pound luminaire having an effective projected area of 1.6 square feet.
3. Fabrication shall be in accordance with the Specifications and with the details, dimensions, and weld procedures shown herein. Do not submit shop drawings for roadway illumination pole assemblies fabricated in accordance with the details, dimensions, and weld procedures shown herein. Weld references call for preapproved weld procedures which the Fabricator must obtain prior to fabrication. Materials, fabrication tolerances, and shipping practices shall meet the requirements of these sheets and the Specifications. In the absence of specified fabrication tolerances, dimensions shall be within the tolerances generally obtainable in normal fabrication practice.
4. For mounting heights between values shown in the tables, use base diameter and thickness values for the larger height.
5. Unless otherwise noted, all steel parts shall be galvanized in accordance with Item 445, "Galvanizing."
6. Steel poles shall be fabricated in accordance with Item 441, "Steel Structures." Longitudinal seam welds for pole sections shall have 60% minimum penetration. All welding shall be in accordance with AWS D1.1, Structural Welding Code-Steel.
7. Two-section poles joined by circumferential welds will not be permitted, unless otherwise shown on the plans. Poles may be fabricated in two sections and field-assembled by the lap-joint method. The two sections shall telescope together with a lap length of not less than 1-1/2 times the shaft diameter at the lap joint.
8. Alternate material equal to or better than material specified may be substituted with the approval of the Engineer.
9. Lubricate and tighten anchor bolts, when erecting shoe base poles and concrete traffic barrier base poles, in accordance with Item 449, "Anchor Bolts."
10. All poles, except Transformer Base Poles, shall have hand holes with reinforcing frames and covers. For ground mounted shoe base poles, hand holes shall be placed 90 degrees to mast arm unless otherwise noted on the plans. For poles mounted on a concrete traffic barrier with one luminaire arm, hand holes shall be located 180 degrees from luminaire arm. For poles mounted on a concrete traffic barrier with two luminaire arms, all hand holes shall be on the same side of the barrier. For poles mounted on a bridge lighting bracket or a retaining wall lighting bracket, hand hole shall be on traffic side of the pole, at a height that will clear the barrier.
11. The finished pole shall have a smooth, uniform finish free of pits, blisters, or other defects. Scratched, chipped, and other damaged galvanized areas on poles and mast arms shall be repaired in accordance with Item 445, "Galvanizing."
12. Pole length is based on a 5'-6" luminaire arm rise. 4 ft. luminaire arms have a 2'-6" rise. A pole with 4 ft. luminaire arms will have an actual mounting height 3'-0" less than the nominal mounting height. Increasing the pole length to meet the nominal mounting height is allowed, but unnecessary unless otherwise directed by the engineer.
13. Erect transformer base poles in accordance with sheet RID(1).

SHEET 2 OF 4

Texas Department of Transportation  
Traffic Safety Division Standard

**ROADWAY ILLUMINATION POLES**

**RIP(2) - 19**

FILE: rip-19.dgn	DN:	CK:	DW:	CK:
© TxDOT January 2007	CONT	SECT	JOB	HIGHWAY
REVISIONS	0918	00	392	VA
7-17	DIST	COUNTY	SHEET NO.	
12-19	DAL	DALLAS, ETC.	70	

DISCLAIMER: The use of this standard is governed by the "Texas Engineering Practice Act". No warranty of any kind is made by TxDOT for any purpose whatsoever. TxDOT assumes no responsibility for the conversion of this standard to other formats or for incorrect results or damages resulting from its use.

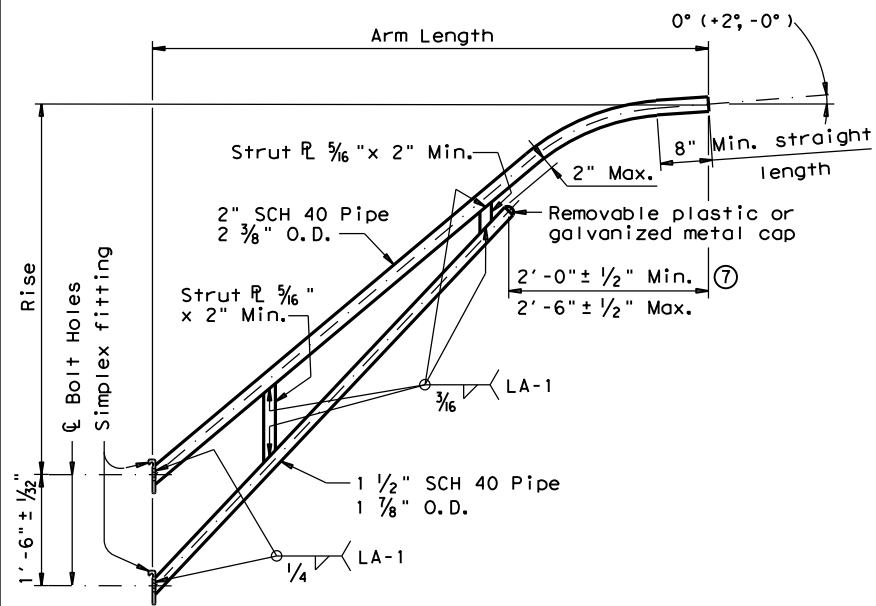

**LUMINAIRE ARM**

LUMINAIRE ARM DIMENSIONS		
Nominal Arm Length	Arm Length	Rise
4'-0"	3'-6"	2'-6"
6'-0"	5'-6"	5'-6"
8'-0"	7'-6"	5'-6"
10'-0"	9'-6"	5'-6"
12'-0"	11'-6"	5'-6"

ARM ASSEMBLY FABRICATION TOLERANCES TABLE	
DIMENSION	TOLERANCE
Arm Length	±1"
Arm Rise	±1"
Deviation from flat	1/8" in 12"
Spacing between holes	±1/32"

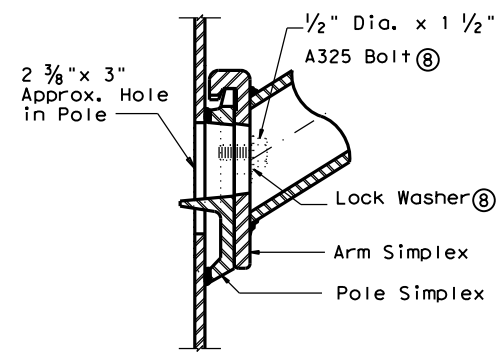

**UPPER SIMPLEX FITTING**  
(Gusset not shown for clarity)

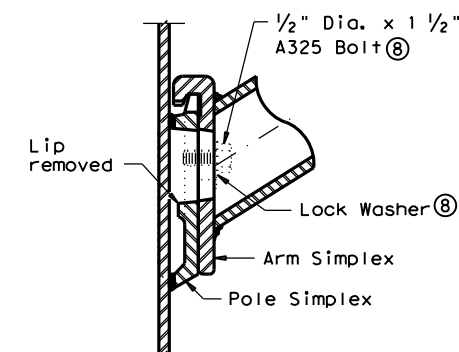

**LOWER SIMPLEX FITTING**  
(Gusset not shown for clarity)  
**SECTION B-B**

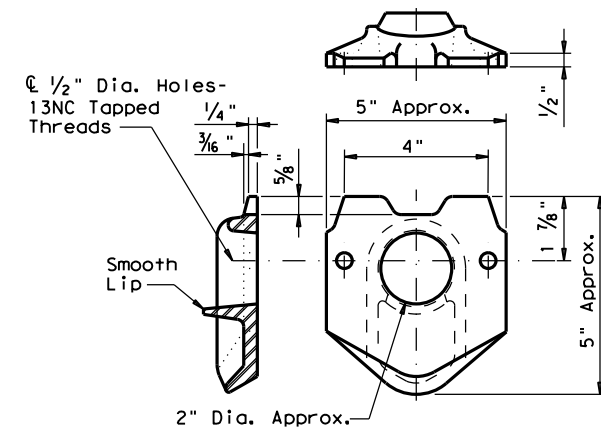

**POLE SIMPLEX DETAIL**

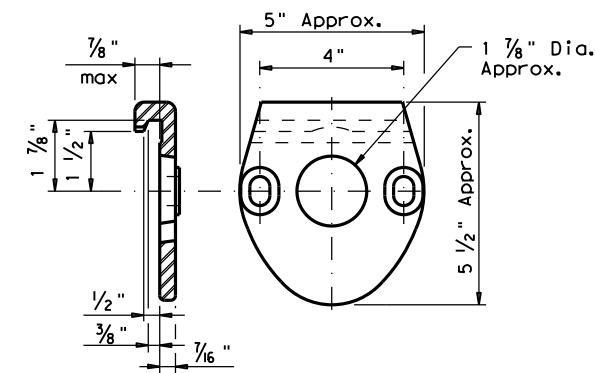

**ARM SIMPLEX DETAIL**

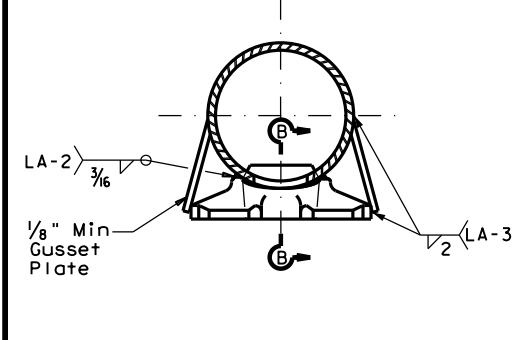
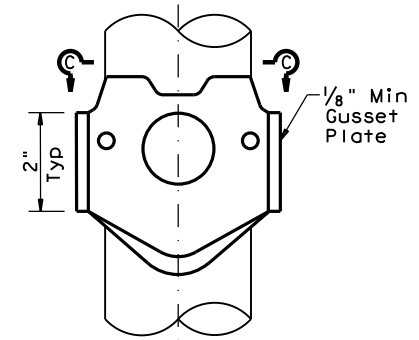
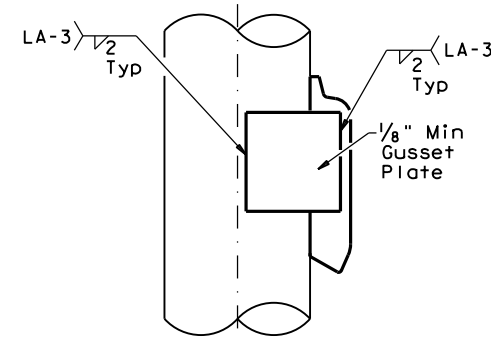

**SIMPLEX ATTACHMENT DETAIL**

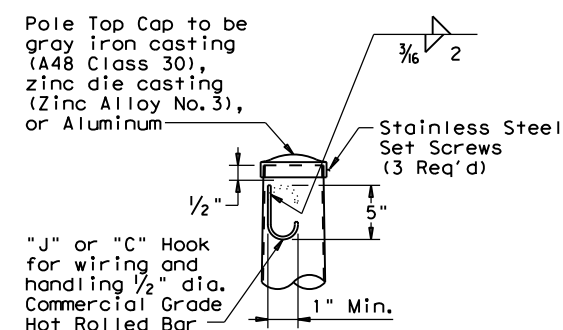

**POLE TOP**

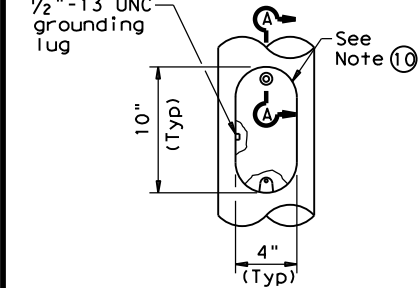

**ELEVATION**

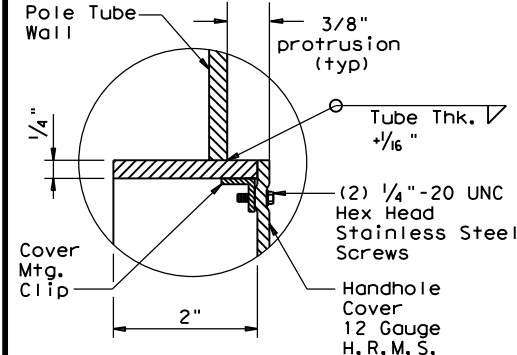

**SECTION A-A**

**HANDHOLE**

**NOTES:**

- ④ Any of the materials listed for plates may be used where the drawings do not specify a particular ASTM designation.
- ⑤ A576 must be suitable for forging and also meet minimum tensile strength of 65 ksi, minimum yield of 35 ksi, and elongation in 2 inches of 22 percent.
- ⑥ A572, A1008 HSLAS-F, and A1011 HSLAS-F materials may have higher yield strengths but shall not have less elongation than the grade indicated.
- ⑦ Dimensional limits are given to show acceptable variation in design. All of a Fabricator's production of a particular arm length shall have the same dimensions within specified tolerances.
- ⑧ Each pole simplex fitting shall be supplied with 2 bolts and 2 lock washers of the size specified. The bolts and lock washers shall be secured to the pole with the other hardware items called for in the plans.
- ⑨ Proposed deviations in arm simplex dimensions or materials must be submitted to the Department for approval.
- ⑩ A welded handhole frame is permissible. Maximum of two (2) CJP weld splices is allowed.

**MATERIALS**

Pole or Arm Simplex	ASTM A27 Gr 65-35 or Gr 70-36, A148 Gr 80-50, A576 Gr 1021 ⑤, or A36 (Arm only)
Arm Pipes	ASTM A53 Gr A or B, A500 Gr B, A501, A 1008 HSLAS-F Gr 50 ⑥, or A1011 HSLAS-F Gr 50 ⑥
Arm Struts and Gusset Plates ④	ASTM A36, A572 Gr 50 ⑥, or A588
Misc.	ASTM designations as noted

**ROADWAY ILLUMINATION POLES**  
**RIP(3) - 19**

FILE: rip-19.dgn	DN:	CK:	DW:	CK:
©TxDOT January 2007	CONT	SECT	JOB	HIGHWAY
REVISIONS	0918	00	392	VA
7-17	DIST	COUNTY	SHEET NO.	
12-19	DAL	DALLAS, ETC.	71	

DISCLAIMER: The use of this standard is governed by the "Texas Engineering Practice Act". No warranty of any kind is made by TxDOT for any purpose whatsoever. TxDOT assumes no responsibility for the conversion of this standard to other formats or for incorrect results or damages resulting from its use.

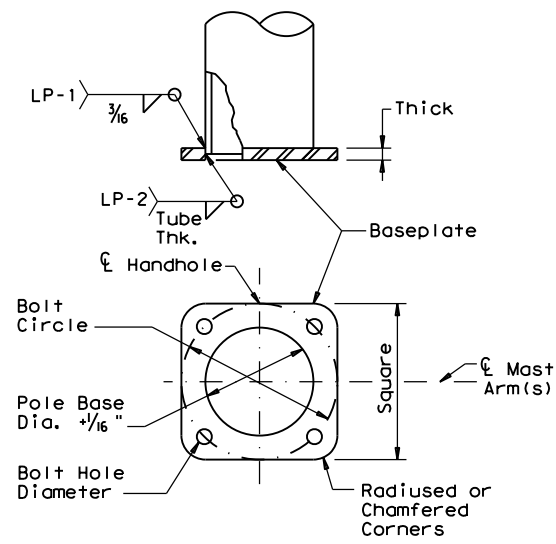

**SHOE BASE BASEPLATE**

MOUNTING HEIGHTS (nominal)	BOLT CIRCLE	SQUARE	THICK	BOLT HOLE DIAMETER
20' - 39'	13"	13"	1 1/4"	1 1/4"
40'	15"	15"	1 1/4"	1 1/2"
50'	15"	15"	1 1/2"	1 1/2"

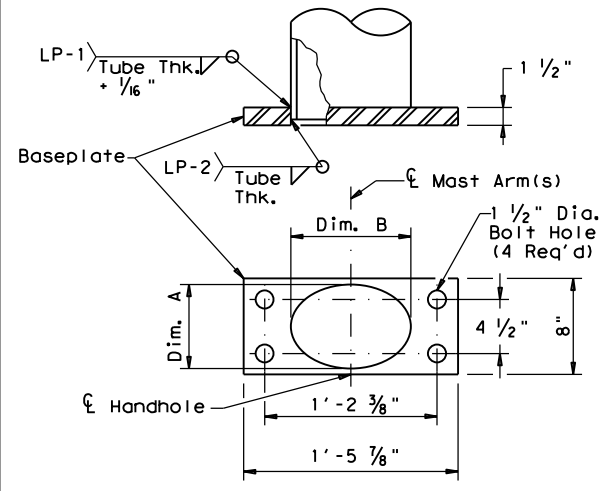

**CONCRETE TRAFFIC BARRIER BASE BASEPLATE**

MOUNTING HEIGHTS (nominal)	POLE DIA. (1)	DIM. A	DIM. B
28' - 38'	9"	7" ± 1/4"	10" ± 1/4"
48'	10 1/2"	7" ± 1/4"	13" ± 1/4"

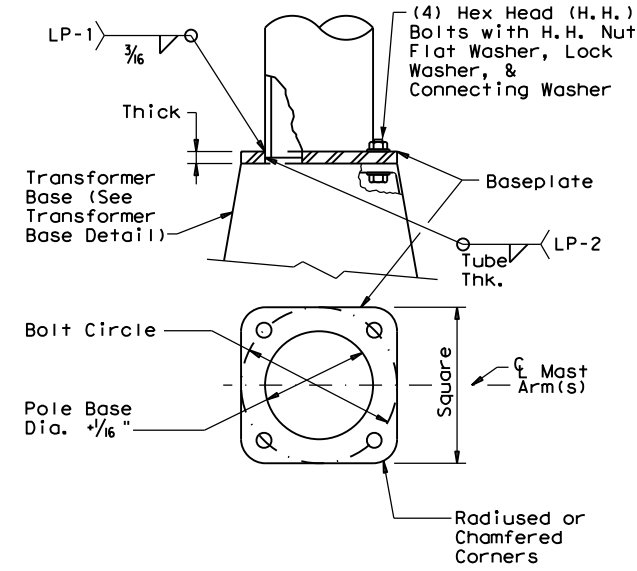

**TRANSFORMER BASE BASEPLATE**

MOUNTING HEIGHTS (nominal)	BOLT CIRCLE	SQUARE	THICK	CONNECTING BOLT DIA.	BOLT HOLE DIAMETER	TRANSFORMER BASE TYPE
20' - 39'	13"	13"	1 1/4"	1"	1 1/4"	A
40'	15"	15"	1 1/4"	1 1/4"	1 1/2"	B
50'	15"	15"	1 1/2"	1 1/4"	1 1/2"	B

TYPE	TOP B.C.	BTM. B.C.
A	13"	14"
B	15"	17 1/4"

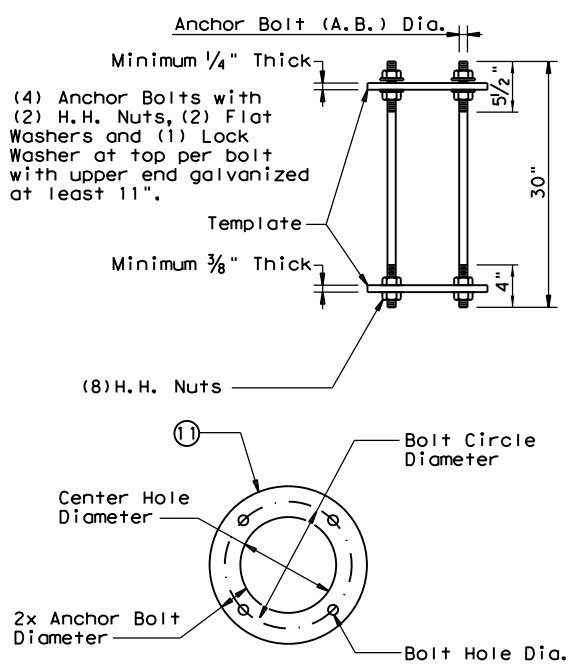
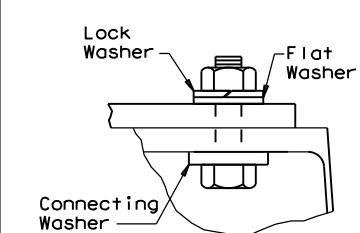
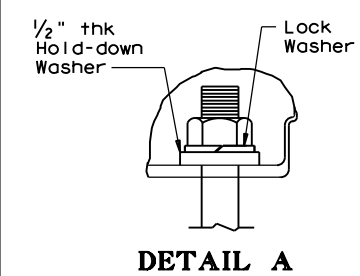

**SHOE BASE ANCHOR BOLT ASSEMBLY**

MOUNTING HEIGHTS (nominal)	A.B. Dia.	BOLT CIRCLE DIAMETER	CTR. HOLE DIAMETER	BOLT HOLE DIAMETER
20' - 39'	1"	13"	11"	1 1/16"
40' - 50'	1 1/4"	15"	12 1/2"	1 5/16"

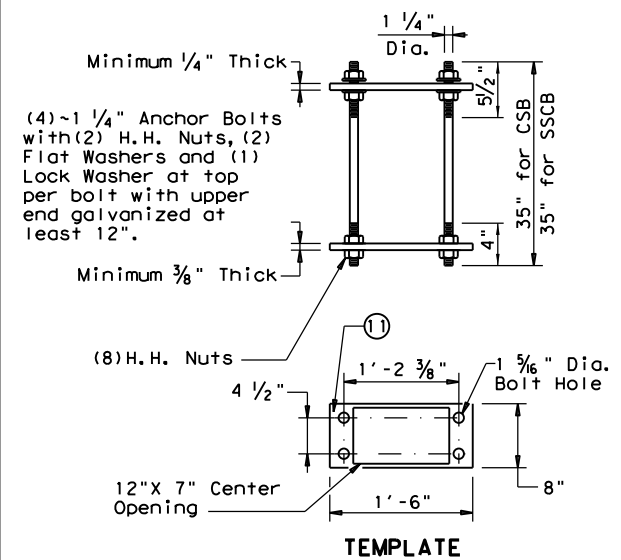

**CONCRETE TRAFFIC BARRIER BASE ANCHOR BOLT ASSEMBLY**

MOUNTING HEIGHTS (nominal)	A.B. Dia.	BOLT CIRCLE DIAMETER	CTR. HOLE DIAMETER	BOLT HOLE DIAMETER
20' - 39'	1"	14"	12"	1 1/16"
40' - 50'	1 1/4"	17 1/4"	14 3/4"	1 5/16"

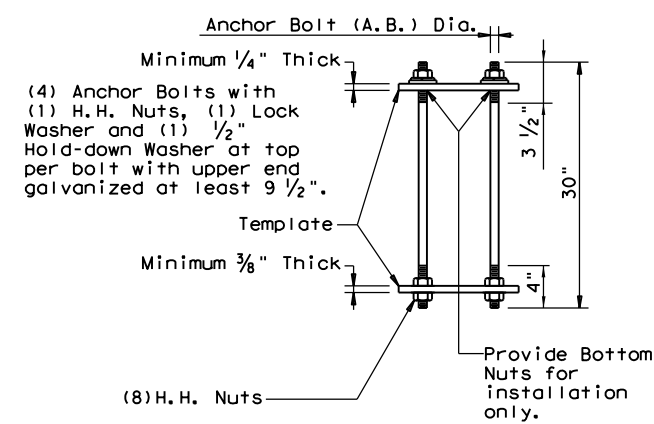

**TRANSFORMER BASE ANCHOR BOLT ASSEMBLY**

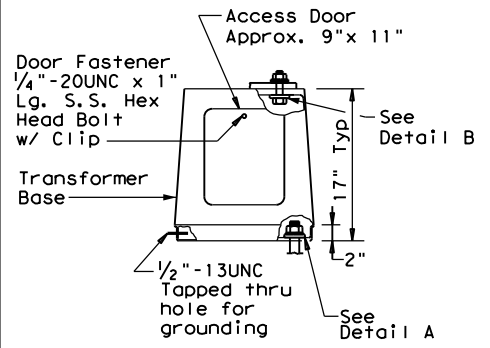
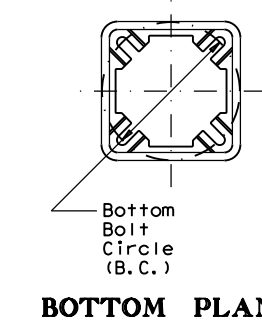
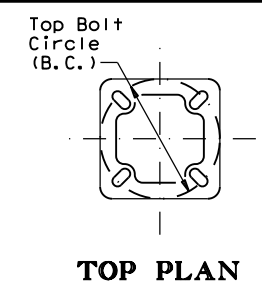

**TRANSFORMER BASE DETAILS**

**GENERAL NOTES:**

- For mounting heights between those shown in the table, use the values in the table for the larger mounting height.
- All breakaway bases shall meet the breakaway requirements of the AASHTO Standard Specifications for Structural Supports for Highway Signs, Luminaires and Traffic Signals, 6th Edition (2013) and Interim Revisions thereto, and shall have been tested by FHWA-approved methods. All bases shall have been structurally tested to resist 150% of the design moment.
- Transformer bases shall be cast from aluminum, ASTM B108 or B26 Alloy 356.0-T6, or other material approved by the Engineer. Four Hex Head (H.H.) bolts with four H.H. nuts, four lock washers, four flat washers, and connecting and hold-down washers as recommended by the manufacturer, galvanized to ASTM A153 Class C or D, or B695 Class 50, shall be provided with each transformer base for connecting the pole. Bolts shall be ASTM A325 or approved equal. Nuts shall be ASTM A563 grade DH galvanized.
- Bases shall be stamped, incised or by other approved permanent means, marked to show fabricator's name or logo, and model number. Such information shall be placed in a readily seen location, inside or outside the base, but shall not be placed on the door.
- Doors for transformer bases shall be made of plastic, fiberglass or other non-metallic material approved by the Engineer and shall be attached with stainless steel screws or bolts. Transformer bases shall be cleaned by grit blast cleaning after heat treatment. Certification by the manufacturer of heat treatment shall be furnished with transformer bases. The certification shall show the metal alloy and temper and that the base meets those requirements, chemical and physical. The certification shall also show the material ASTM specification. Transformer bases shall be cast with a removable tab bar for material testing. Some bars may have been removed by the manufacturer for testing.

**NOTES:**

- Anchor Bolt Templates do not need to be galvanized.
- Pole diameter before ovalized.

DIMENSION	TOLERANCE
Length	± 1/2"
Threaded length	± 1/2"
Galvanized length (if required)	- 1/4"

SHEET 4 OF 4

Texas Department of Transportation  
Traffic Safety Division Standard

## ROADWAY ILLUMINATION POLES

### RIP(4) - 19

FILE: rip-19.dgn	DN:	CK:	DW:	CK:
© TxDOT January 2007	CONT	SECT	JOB	HIGHWAY
REVISIONS	0918	00	392	VA
7-17	DIST	COUNTY	SHEET NO.	
12-19	DAL	DALLAS, ETC.	72	

DATE: FILE:



DISCLAIMER: The use of this standard is governed by the "Texas Engineering Practice Act". No warranty of any kind is made by TxDOT for any purpose whatsoever. TxDOT assumes no responsibility for the conversion of this standard to other formats or for incorrect results or damages resulting from its use.

DATE: 2/14/2024 3:20:34 PM  
 U:\TRAFFIC PROJECTS\0918-00-392 Non-Site 9-24\Microstation Files\073 SNS-95.dgn

## INTERNALLY LIGHTED STREET NAME SIGN DETAILS

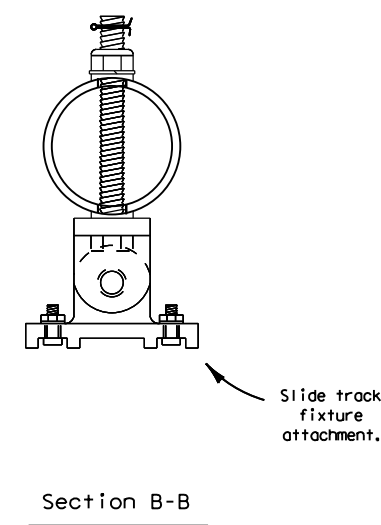
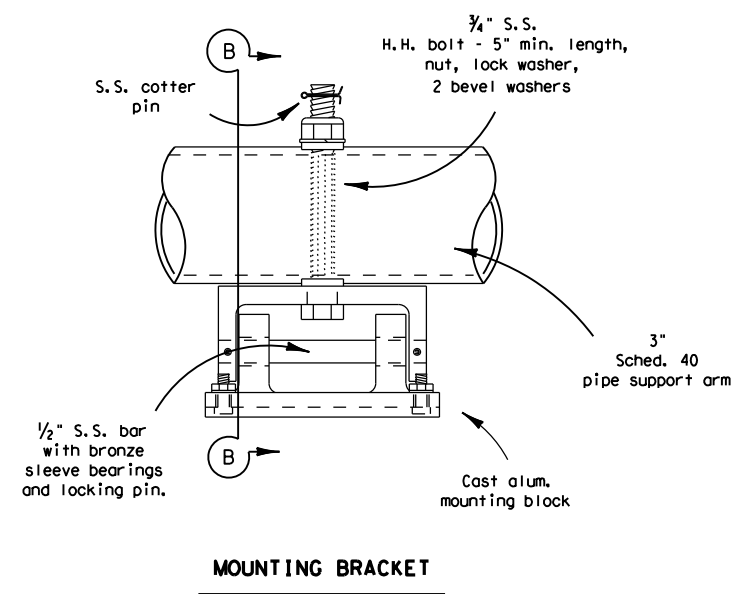
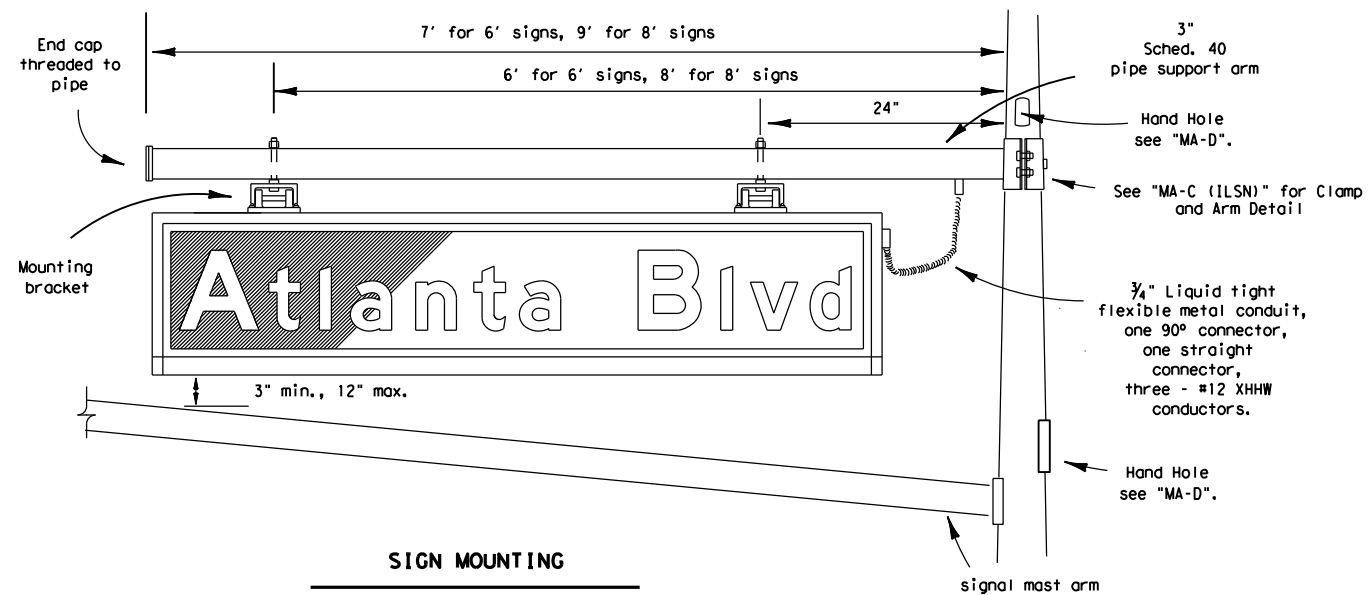
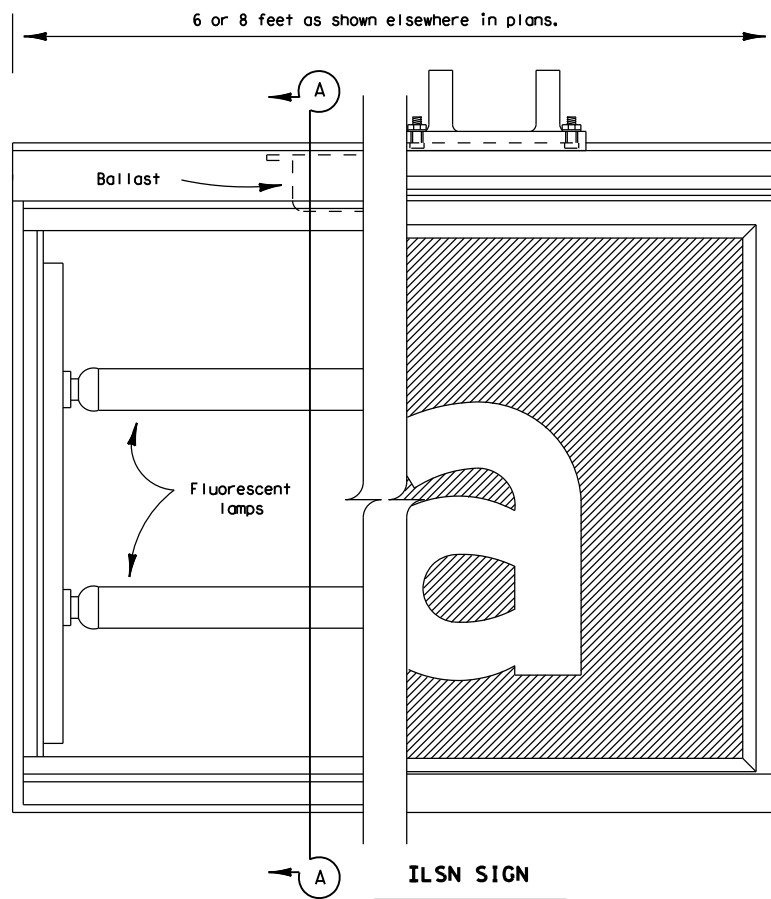
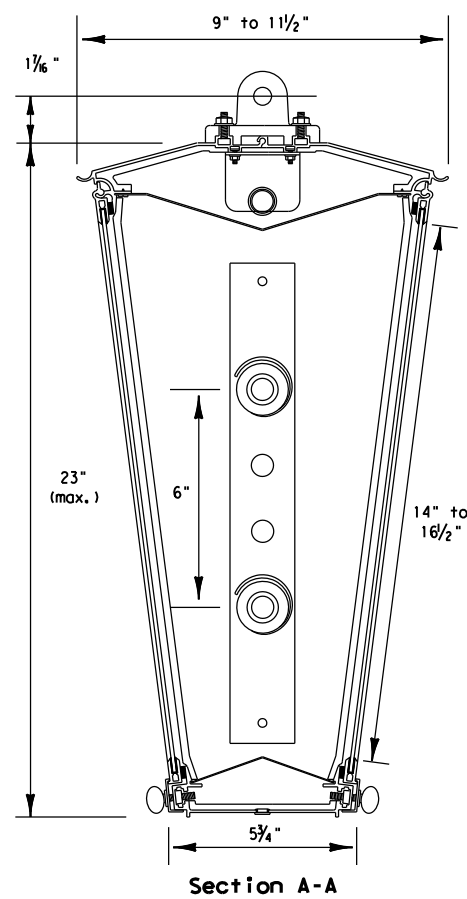

### ILSN SIGN NOTES:

1. Eight foot ILSN sign shall not exceed 11.5 sq.ft. effective projected area (EPA) and shall not exceed a weight of 85 lbs.  
Six foot ILSN sign shall not exceed 8.7 sq.ft. EPA and shall not exceed a weight of 70 lbs.
2. Sign message shall be as shown elsewhere in the plans.
3. See Special Specification, "Internally Lighted Street Name Signs" for additional details.

### EXPLANATION OF DESCRIPTION

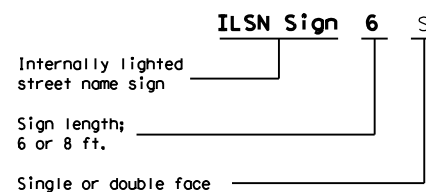

Texas Department of Transportation  
 Traffic Operations Division

## STREET NAME SIGN DETAILS (ILLUMINATED)

SNS-95

© TxDOT August 1995		DN: TxDOT	CK: TxDOT	DW: TxDOT	CK: TxDOT
REVISIONS					
CONT	SECT	JOB	HIGHWAY		
091800		392	VA		
DIST	COUNTY	SHEET NO.			
DAL	DALLAS, ETC.	73			



DISCLAIMER: The use of this standard is governed by the "Texas Engineering Practice Act". No warranty of any kind is made by TxDOT for any purpose whatsoever. TxDOT assumes no responsibility for the conversion of this standard to other formats or for incorrect results or damages resulting from its use.

DATE:  
FILE:

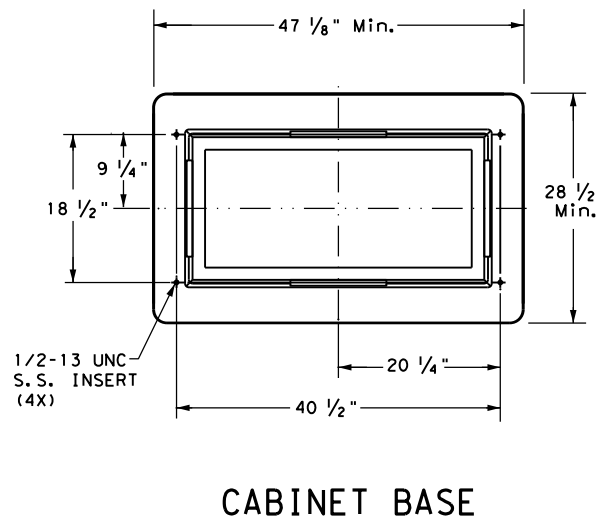
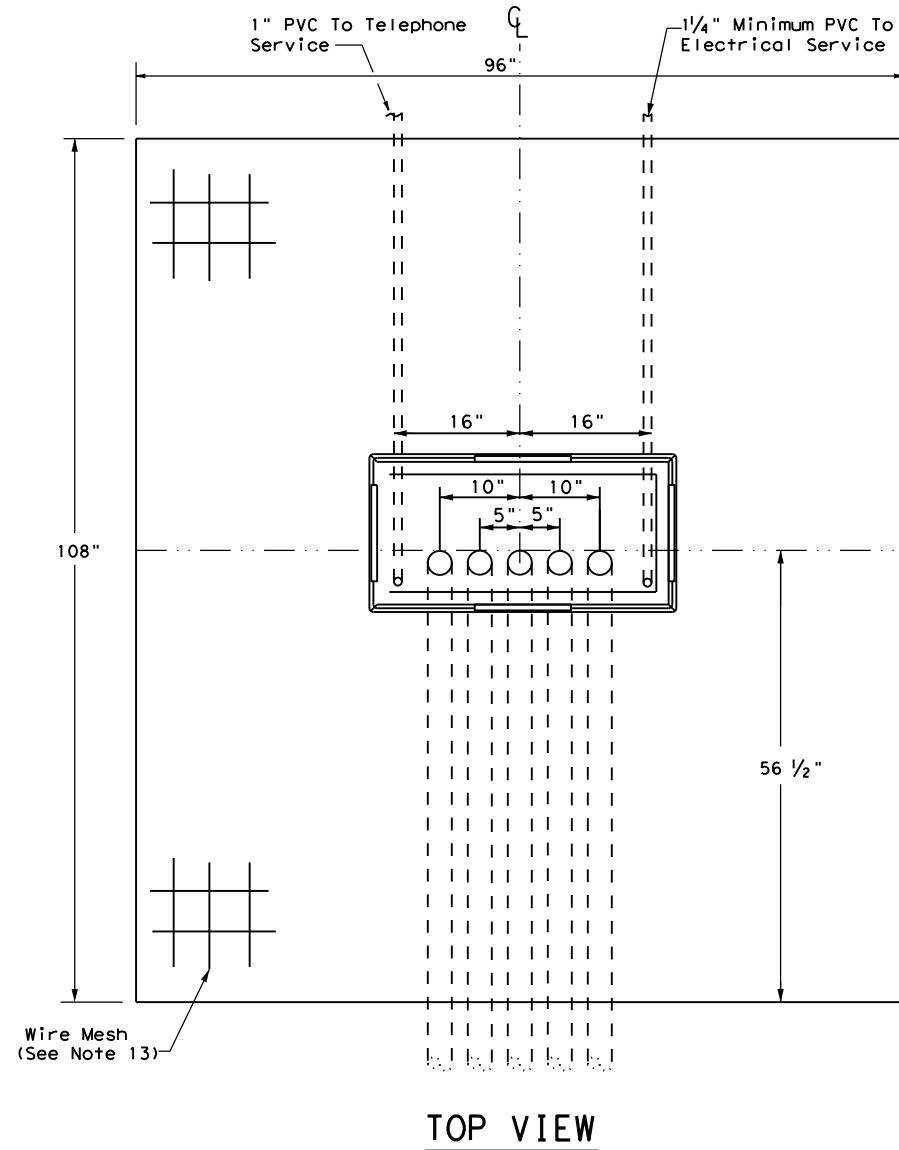

**CABINET BASE**

**TRAFFIC SIGNAL CONTROLLER BASE:**

1. Provide a traffic signal controller base (cabinet base) manufactured of polymer concrete material consisting of calcareous and siliceous stone; glass fibers and thermoset polyester resin. The polymer concrete cabinet base must be reinforced on the inside of the cabinet base with fiberglass matting. Provide one of the following bases: Armorcast Part # A6001848X24, Quazite Model # PG3048Z709, or other as approved by TxDOT Traffic Safety Division.
2. The polymer concrete material must have a minimum compressive strength of 10,300 pounds per square inch (psi), minimum flexural strength of 3600 psi, and minimum shear strength of 3600 psi.
3. The polymer concrete cabinet base must conform to the dimensions shown and must accommodate a standard TxDOT basemount cabinet.
4. Supply the cabinet base with four 1#2"-13 UNC stainless steel inserts for attachment of the cabinet to the base. Inserts must withstand a minimum torque of 50 ft-lb and a minimum straight pull out strength of 750 lbs.
5. Provide the cabinet base with 4 cable racks mounted one on each side of the base 2" to 7" from the top edge of the base. Unless approved otherwise, cable racks must be 1-1/2 x 9#16x 3#16inch steel channel with eight T-slots spaced at 1-1/2 inches. The cable racks must easily accommodate the insertion of tie wraps to attach field wiring to the racks to serve as strain relief. Secure cable racks to the base using 1#2"-13 UNC stainless steel screws and inserts.
6. The cabinet base, when secured to the concrete slab with controller cabinet attached, must withstand a minimum wind load of 125 mph or a 850 lb force applied at 49" above the bottom of the base without causing the base or cabinet to come out of their anchored position or cause any permanent deformation. The manufacturer must supply certification by an independent testing laboratory or sealed by a Texas Licensed Professional Engineer. Provide the cabinet base with hardware for attachment to a concrete slab.
7. The traffic signal base must be permanently marked either by impress or by permanent ink with the manufacturer's model number and name or logo.
8. Seal the base to the concrete with a silicone caulk bead and fastened to the slab per manufacturer's instructions.

**CONCRETE SLAB:**

9. Traffic signal controller pad must be a portland cement concrete slab poured in place, must conform to the dimensions shown, and must be level.
10. Grade earthwork such that it is flush with the concrete pad on all four sides, unless otherwise shown on the plans. Subsidiary to ITEM 680, four inch rip rap may be used in lieu of earthwork. Slopes shall gradually contour to match plans.
11. Bond a #8 AWG copper ground wire and an 8 ft ground rod bonded to the reinforcing mesh by a suitable UL Listed clamp and terminated to the cabinet grounding bus for the purpose of providing a local ground for the electrical grounding conductor. The electrical grounding conductor specified in Item 680-3.A.4 is required and must be terminated to the cabinet ground bus.
12. Install a PVC sleeve to prevent the ground rod from direct embedment in the slab.
13. Provide welded wire mesh 6X6-W2.9 X W2.9 for reinforcement. Provide joints and splices in the mesh with a minimum 6-inch overlap. Center the mesh between top and bottom and provide a minimum 3 inch cover on the edges.
14. Provide Class B concrete minimum for the slab in accordance with Item 421. Construct the slab in accordance with Item 531.

**CONDUITS:**

15. Stub up and run 3-inch conduits through the slab to the various traffic signal poles and ground boxes as shown on the layouts. Install the number of conduits as shown on layouts plus two additional 3 inch conduits for future use. Terminate the conduits with a bushing between 2 and 4-inches above the slab.
16. Extend conduits for future use at least 18-inches from the edge of the slab, terminate underground with a coupling, and cap and seal so that the seal can be removed without damaging the coupling. This must also apply to unused telephone conduit.
17. Stub up two separate conduits through the slab from the electrical and telephone services. Run the conduit for the electrical feed directly to the electrical service enclosure. Run the conduit for the telephone line directly to the telephone service, usually located on the same pole as the electrical service. Telephone must not under any circumstance share a conduit with any other function.
18. Terminate electric and telephone conduits above the slab with a coupling. After the base is installed, extend the conduits above the top of the base and secure to the base using a steel one-hole strap or similar suitable substitute.

**CONTROLLER CABINET:**

19. Anchor the controller cabinet to the base using four stainless steel 1/2-13 NC bolts.
20. The silicone caulk bead specified in Item 680.3.B must be RTV 133.

**PAYMENT:**

21. Bid TS-CF as subsidiary to Item 680.

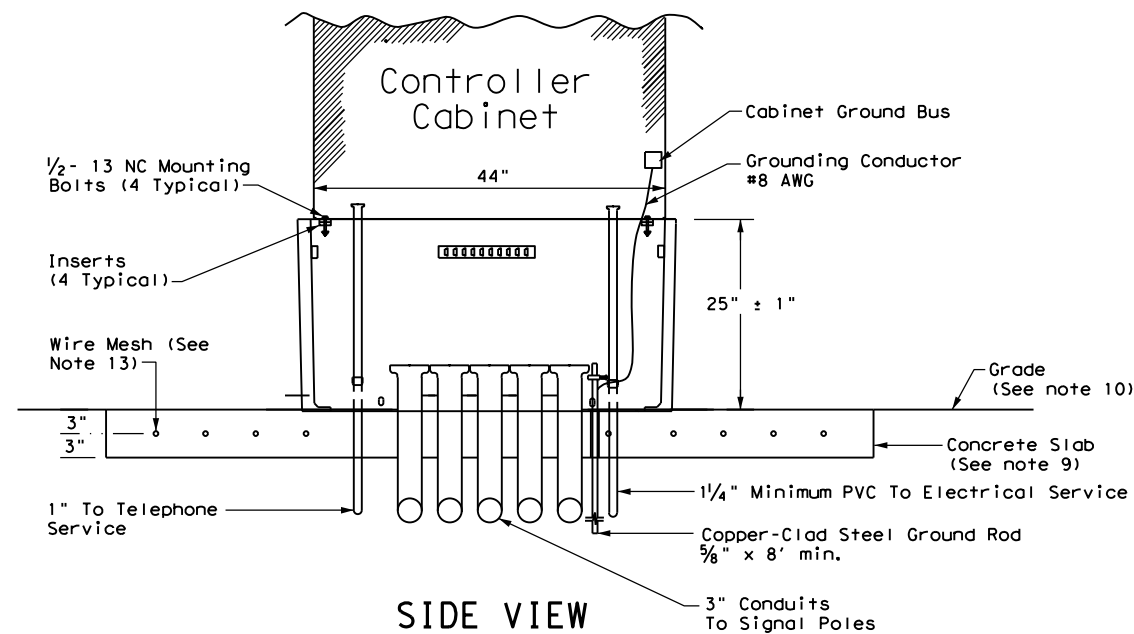

**SIDE VIEW**

		<b>Traffic Safety Division Standard</b>	
<b>TRAFFIC SIGNAL CONTROLLER CABINET BASE AND PAD</b> <b>TS-CF-21</b>			
FILE: ts-cf-21.dgn	DN:	CK:	CK:
© TxDOT October 2000	CONT	SECT	JOB
12-04	0918	00	392
2-21	DIST	COUNTY	SHEET NO.
	DAL	DALLAS, ETC.	75

DISCLAIMER: The use of this standard is governed by the "Texas Engineering Practice Act". No warranty of any kind is made by TxDOT for any purpose whatsoever. TxDOT assumes no responsibility for the conversion of this standard to other formats or for incorrect results or damages resulting from its use.

DATE: 2/14/2024 3:23:13 PM  
 U:\TRAFFIC PROJECTS\0918-00-392 Non-Site 9-24\Microstation Files\076 ED(1)-14.dgn

**GENERAL NOTES FOR ALL ELECTRICAL WORK**

- The location of all conduits, junction boxes, ground boxes, and electrical services is diagrammatic and may be shifted to accommodate field conditions.
- Provide new and unused materials. Ensure that all materials and installations comply with the applicable articles of the National Electrical Code (NEC), TxDOT standards and specifications, National Electrical Manufacturers Association (NEMA), and are listed by Underwriters Laboratories (UL) or a Nationally Recognized Testing Lab (NRTL). NRTLs such as Canadian Standard Association (CSA), Intertek Testing Services NA Inc., or FM Approvals LLC can be considered equivalent to UL. Where reference is made to NEMA listed devices, International Electrotechnical Commission (IEC) listed devices will not be considered an acceptable equal to a NEMA listed device. Acceptable devices may have both a NEMA and IEC listing. Faulty fabrication or poor workmanship in any material, equipment, or installation is justification for rejection. Replace or reinstall rejected material or equipment at no additional cost to the Department.
- Miscellaneous nuts, bolts and hardware, except for high strength bolts, may be stainless steel when plans specify galvanized, provided the bolt size is 1/2 in. or less in diameter.
- Provide the following test equipment as required by the Engineer to confirm compliance with the contract and the NEC: voltmeter, ammeter, megohm meter (1000 volt DC), ground resistance tester, torque wrenches, and torque screwdrivers. Ensure all equipment has been properly calibrated within the last year. Provide calibration certification to the Engineer upon request. Operate test equipment during inspection as requested by the Engineer.
- Install grounding as shown on the plans and in accordance with the NEC. Ensure all metallic conduits; metal poles; luminaires; and metal enclosures are bonded to the equipment grounding conductor. Provide stranded bare copper or green insulated grounding conductors. Ground rods, connectors, and bonding jumpers are subsidiary to the various bid items.
- When required by the Engineer, notify the Department in writing of materials from the Material Producers List (MPL) intended for use on each project. Prequalified materials are listed on the MPL on TxDOT's website under "Roadway Illumination and Electrical Supplies." No substitutions will be allowed for materials on this list.

**CONDUIT**

**A. MATERIALS**

- Provide conduit, junction boxes, fittings, and hardware as per TxDOT Departmental Material Specification (DMS) 11030 "Conduit" and Item 618 "Conduit" of TxDOT's "Standard Specifications For Construction And Maintenance Of Highways, Streets, And Bridges," latest edition. Provide conduits listed under Item 618 on the MPL under "Roadway Illumination and Electrical Supplies." Provide conduit types according to the descriptive code or as shown on the plans. Do not substitute other types of conduits for those shown. Provide liquidtight flexible metal conduit (LFMC) when flexible conduit is called for on galvanized steel rigid metallic conduit (RMC) systems. Provide liquidtight flexible nonmetallic conduit (LFNC) when flexible conduit is called for on polyvinyl chloride (PVC) systems.
- Provide galvanized steel RMC for all exposed conduits, unless otherwise shown on the plans. Properly bond all metal conduits.
- Unless otherwise shown on the plans, provide junction boxes with a minimum size as shown in the following table, which applies to the greatest number of conductors entering the box through one conduit with no more than four conduits per box. When a mixture of conductor sizes is present, count the conductors as if all are of the larger size. For situations not applicable to the table, size junction boxes in accordance with NEC.

AWG	3 CONDUCTORS	5 CONDUCTORS	7 CONDUCTORS
#1	10" x 10" x 4"	12" x 12" x 4"	16" x 16" x 4"
#2	8" x 8" x 4"	10" x 10" x 4"	12" x 12" x 4"
#4	8" x 8" x 4"	10" x 10" x 4"	10" x 10" x 4"
#6	8" x 8" x 4"	8" x 8" x 4"	10" x 10" x 4"
#8	8" x 8" x 4"	8" x 8" x 4"	8" x 8" x 4"

- Junction boxes with an internal volume of less than 100 cu. in. and supported by entering raceways must have threaded entries or hubs identified for the intended purpose and supported by connection of two or more rigid metal conduits. Secure conduit within 3 ft. of the enclosure or within 18 in. of the enclosure if all conduit entries are on the same side. Mechanically secure all junction boxes with an internal volume greater than 100 cu. inches.
- Provide hot dipped galvanized cast iron or sand cast aluminum outlet boxes for junction boxes containing only 10 AWG or 12 AWG conductors. Do not use die cast aluminum boxes. Size outlet boxes according to the NEC.
- Do not use intermediate metal conduit (IMC) or electrical metallic tubing (EMT) unless specifically required by the plan sheets. When EMT is called for, provide junction boxes made from galvanized steel sheeting, listed and approved for outdoor use, unless otherwise noted on the plans. Size all galvanized steel junction boxes in accordance with the NEC. Provide junction boxes for IMC conduit systems that meet the same requirements for junction boxes used with RMC systems.
- Provide PVC junction boxes intended for outdoor use on PVC conduit systems, unless otherwise noted on the plans.

- Provide PVC elbows in PVC conduit systems, unless otherwise shown on the plans. Use only a flat, high tensile strength polyester fiber pull tape for pulling conductors through the PVC conduit system. When galvanized steel RMC elbows are specifically called for in the plans and any portion of the RMC elbow is buried less than 18 in., ground the RMC elbow by means of a grounding bushing on a rigid metal extension. Grounding of the rigid metal elbow is not required if the entire RMC elbow is encased in a minimum of 2 in. of concrete. PVC extensions are allowed on these concrete encased rigid metal elbows. RMC or PVC elbows are subsidiary to various bid items.
- When required, provide High-Density Polyethylene (HDPE) conduit with factory installed internal conductors according to Item 622 "Duct Cable." At the Contractor's request and with approval by the Engineer, substitute HDPE conduit with no conductors for bored schedule 40 or schedule 80 PVC conduit bid under Item 618. Ensure bored HDPE substituted for PVC is schedule 40 and of the same size PVC called for in the plans. Ensure the substituted HDPE meets the requirements of Item 622, except that the conduit is supplied without factory-installed conductors. Make the transition of the HDPE conduit to PVC (or RMC elbow when required) at the bore pit. Provide conduit of the size and schedule as shown on the plans. Do not extend substituted conduit into ground boxes or foundations. Provide PVC or galvanized steel RMC elbows as called for at all ground boxes and foundations.
- Use two-hole straps when supporting 2 in. and larger conduits. On electrical service poles, properly sized stainless steel or hot dipped galvanized one-hole standoff straps are allowed on the service riser conduit.

**B. CONSTRUCTION METHODS**

- Provide and install expansion joint conduit fittings on all structure-mounted conduits at the structure's expansion joints to allow for movement of the conduit. In addition, provide and install expansion joint fittings on all continuous runs of galvanized steel RMC conduit externally exposed on structures such as bridges at maximum intervals of 150 ft. When requested by the project Engineer, supply manufacturer's specification sheet for expansion joint conduit fittings. Repair or replace expansion joint fittings that do not allow for movement at no additional cost to the Department. Provide the method of determining the amount of expansion to the Engineer upon request. Do not use LFMC or LFNC as a substitute for the required expansion conduit fittings.
- Space all conduit supports at maximum intervals of 5 ft. Install conduit spacers when attaching metal conduit to surface of concrete structures. See "Conduit Mounting Options" on ED(2). Install conduit support within 3 ft. of all enclosures and conduit terminations.
- Do not attach conduit supports directly to pre-stressed concrete beams except as shown specifically in the plans or as approved by the Engineer.
- Unless otherwise shown on the plans, jack or bore conduit placed beneath existing roadways, driveways, sidewalks, or after the base or surfacing operation has begun. Backfill and compact the bore pits below the conduit per Item 476 "Jacking, Boring, or Tunneling Pipe or Box" prior to installing conduit or duct cable to prevent bending of the connections.
- When placing conduit in the sub-grade of new roadways, backfill all trenches with excavated material unless otherwise noted on the plans. When placing conduit in the sub-base of new roadways, backfill all trenches with cement-stabilized base as per requirements of Items 110 "Excavation", 400 "Excavation and Backfill for Structures", 401 "Flowable Backfill", 402 "Trench Excavation Protection", and 403 "Temporary Special Shoring."
- Provide and place warning tape approximately 10 in. above all trenched conduit as per Item 618.
- During construction, temporarily cap or plug open ends of all conduit and raceways immediately after installation to prevent entry of dirt, debris and animals. Temporary caps constructed of durable duct tape are allowed. Tightly fix the tape to the conduit opening. Clean out the conduit and prove it clear in accordance with Item 618 prior to installing any conductors.
- Ensure conduit entry into the top of any enclosure is waterproof by installing conduit sealing hubs or using boxes with threaded bosses. This includes surface mounted safety switches, meter cans, service enclosures, auxiliary enclosures and junction boxes. Grounding bushings on water tight sealing hubs are not required.
- Fit the ends of all PVC conduit terminations with bushings or bell end fittings. Provide and install a grounding type bushing on all metal conduit terminations.
- Install a bonding jumper from each grounding bushing to the nearest ground rod, grounding lug, or equipment grounding conductor. Ensure all bonding jumpers are the same size as the equipment grounding conductor. Bonding of conduit used as a casing under roadways for duct cable is not required, if the duct extends the full length through the casing.
- At all electrical services, install a 6 AWG solid copper grounding electrode conductor.
- Place conduits entering ground boxes so that the conduit openings are between 3 in. and 6 in. from the bottom of the box. See the ground box detail on sheet ED(4).
- Seal ends of all conduits with duct seal, expandable foam, or by other methods approved by the Engineer. Seal conduit immediately after completion of conductor installation and pull tests. Do not use duct tape as a permanent conduit sealant. Do not use silicone caulk as a conduit sealant.
- File smooth the cut ends of all mounting strut and conduit. Before installing, paint the field cut ends of all mounting strut and RMC (threaded or non-threaded) with zinc rich paint (94% or more zinc content) to alleviate overspray. Use zinc rich paint to touch up galvanized material as allowed under Item 445 "Galvanizing." Do not paint non-galvanized material with a zinc rich paint as an alternative for materials required to be galvanized.

				Traffic Operations Division Standard	
<h2>ELECTRICAL DETAILS CONDUITS &amp; NOTES</h2>					
<h3>ED(1) - 14</h3>					
FILE:	ed1-14.dgn	DW:	CK:	DW:	CK:
© TxDOT	October 2014	CONT	SECT	JOB	HIGHWAY
REVISIONS		091800	392	VA	
	DIST	COUNTY		SHEET NO.	
	DAL	DALLAS, ETC.		76	

DISCLAIMER: The use of this standard is governed by the "Texas Engineering Practice Act". No warranty of any kind is made by TxDOT for any purpose whatsoever. TxDOT assumes no responsibility for the conversion of this standard to other formats or for incorrect results or damages resulting from its use.

DATE: 2/14/2024 3:23:39 PM  
 U:\TRAFFIC PROJECTS\0918-00-392 Non-Site 9-24\Microstation Files\077 ED(2)-14.dgn

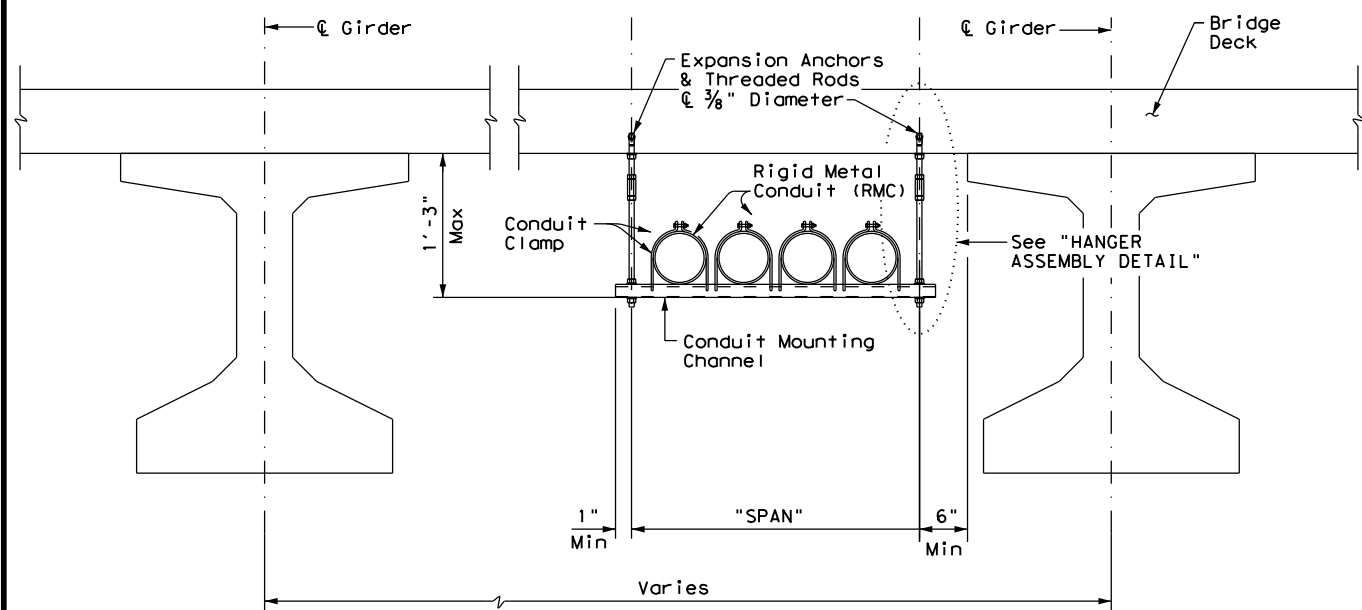

CONDUIT HANGING DETAIL

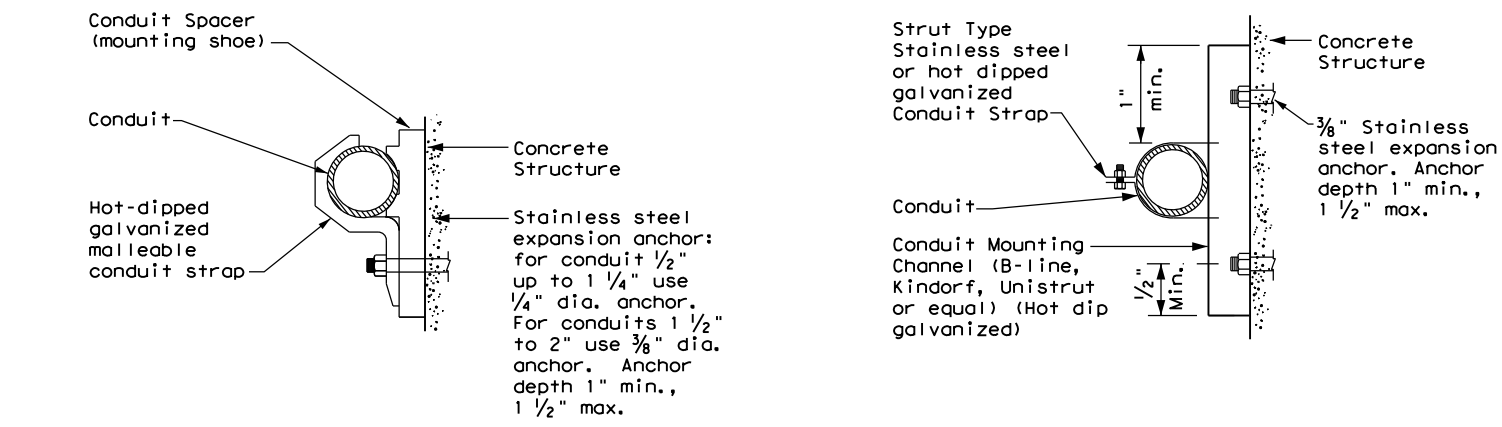

CONDUIT MOUNTING OPTIONS  
 Attachment to concrete surfaces  
 See ED(1)B.2

CONDUIT MOUNTING CHANNEL		
"SPAN"	"W" x "H"	"T"
less than 2'	1 5/8" x 1 3/8"	12 Ga.
2'-0" to 2'-6"	1 5/8" x 1 5/8"	12 Ga.
>2'-6" to 3'-0"	1 5/8" x 2 7/16"	12 Ga.

Channels with round or short slotted hole patterns are allowed, if the load carrying capacity is not reduced by more than 15%.

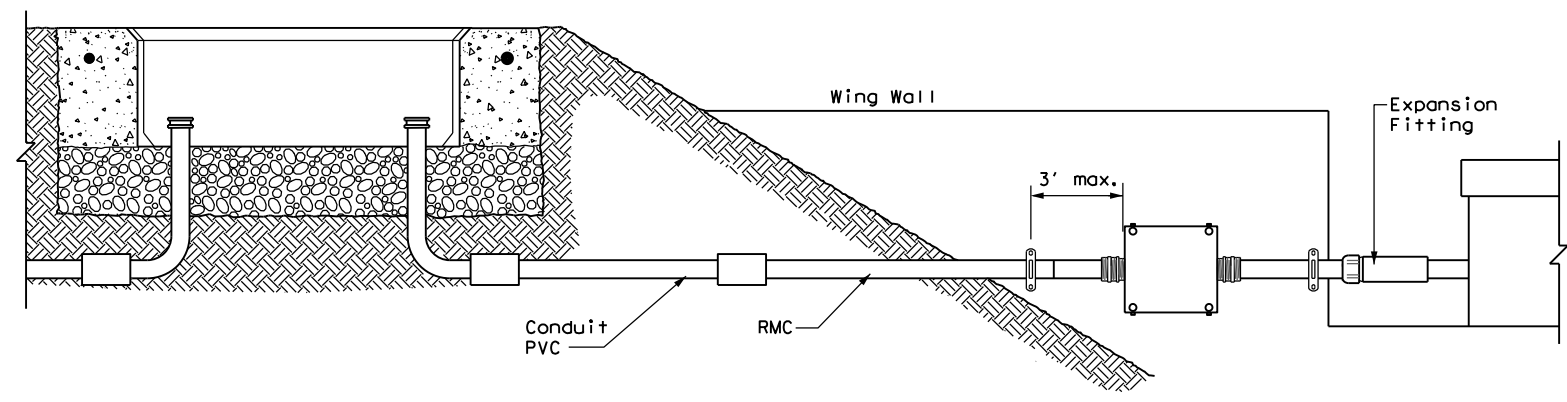

TYPICAL CONDUIT ENTRY TO BRIDGE STRUCTURE DETAIL

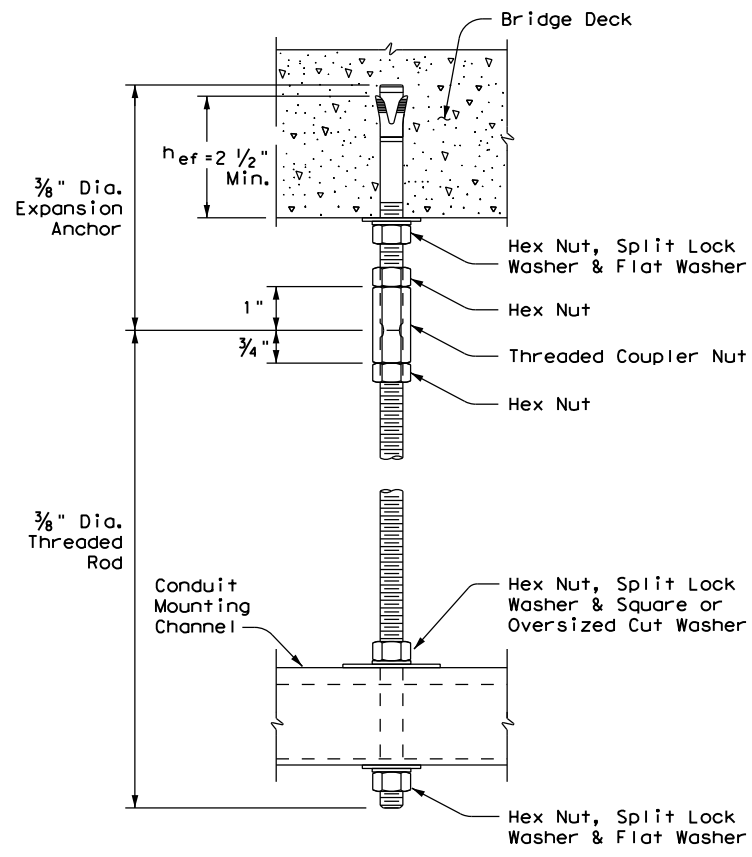

HANGER ASSEMBLY DETAIL

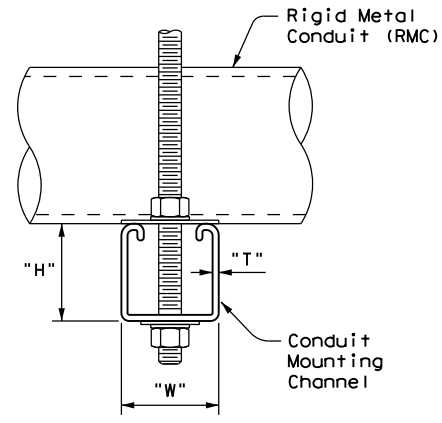

ELECTRIC CONDUIT TO BRIDGE DECK ATTACHMENT

EXPANSION ANCHOR NOTES FOR BRIDGE DECK ATTACHMENT

1. Use torque controlled mechanical expansion anchors that are approved for use in cracked concrete by the International Code Council, Evaluation Service (ICC-ES). The chosen anchor product shall have a designated ICC-ES Evaluation Report number, and its approval status shall be maintained on the ICC-ES website under Division 031600 for Concrete Anchors.
2. Unless otherwise approved by the Engineer: do not use adhesive anchors; do not use expansion anchors that are not included in the ICC-ES approval list; and do not use expansion anchors that are only approved for use in uncracked concrete.
3. Use anchors manufactured with stainless steel expansion wedges. Anchors manufactured with carbon steel expansion wedges are not allowed. Anchor bodies can be either zinc-plated carbon steel or stainless steel. For application in marine environment, both the anchor body and expansion wedge shall be stainless steel.
4. Install anchors as shown on the plans and in accordance with the anchor manufacturer's published installation instructions. Arrange a field demonstration test to evaluate the procedures and tools. The test shall be witnessed and approved by the Engineer prior to furnishing anchors on the structure.
5. Prior to hole drilling, use rebar locator to ensure clearing of existing deck strands or reinforcement. Install anchors to ensure a minimum effective embedment depth, ( $h_{ef}$ ), as shown. Increase ( $h_{ef}$ ) as needed to ensure sufficient thread length for proper torquing and tightening of anchors.
6. Use anchors of minimum 1600 Lbs tensile capacity (minimum of steel, concrete breakout, and concrete pullout strengths as determined by ACI 318 Appendix D) at the required minimum embedment depth ( $h_{ef}$ ). No lateral loads shall be introduced after conduit installation.

		Traffic Operations Division Standard	
<h2>ELECTRICAL DETAILS CONDUIT SUPPORTS</h2>			
<h3>ED(2) - 14</h3>			
FILE: ed2-14.dgn	DN: TxDOT	CK: TxDOT	DW: TxDOT
© TxDOT October 2014	CONT SECT	JOB	HIGHWAY
REVISIONS	0918 00	392	VA
DIST	COUNTY	SHEET NO.	
DAL	DALLAS, ETC.	77	

# ELECTRICAL CONDUCTORS

## A. MATERIAL INFORMATION

1. Provide Type XHHW insulated conductors in accordance with Departmental Material Specification (DMS) 11040 "Conductors" and Item 620 "Electrical Conductors." Provide conductors as listed on the Material Producers List (MPL) on the Department web site under "Roadway Illumination and Electrical Supplies" Item 620. Color code insulated conductors in conformance with the NEC. Identify grounded (neutral) conductors with white insulation. Identify grounding conductors (ground wires) with green insulation or bare conductors. Identify ungrounded (hot) conductors with any color insulation except green, white, or gray. Keep color scheme consistent throughout the wiring system. Identify conductors 6 American Wire Gauge (AWG) and smaller by continuous color jacket. Identify electrical conductors 4 AWG and larger by continuous color jacket or by colored tape. When identifying conductors with colored tape, mark at least 6 in. of the conductor's insulation with half laps of tape.
2. Provide a solid copper 6 AWG grounding electrode conductor to bond the electrical service equipment to the concrete encased grounding electrode or the ground rod at the service location. Connect the grounding electrode conductor to the ground rod with a UL listed connector in accordance with DMS 11040. Connect the grounding electrode conductor to the concrete encased grounding electrode as shown in the plans.
3. Where two or more circuits are present in one conduit or enclosure, permanently identify the conductors of each branch circuit by attaching a non-metallic tag around both circuit conductors at each accessible location. Provide tags with two straps, large enough to indicate circuit number, letter, or other identification as shown in the plans. Print circuit identification on the tag with a permanent marker.
4. Use listed compression or screw type pressure connectors, terminal blocks, or split bolt connectors for splicing as specified in DMS 11040. Use hot melt adhesive tape to fill the gap and seal the ends of heat shrink tubing. Provide UL listed gel-filled insulating splice covers. Splicing materials, insulating materials, breakaway disconnects, splice covers, and fuse holders are subsidiary to various bid items.

## B. CONSTRUCTION METHODS

1. Use only a flat, high tensile strength polyester fiber pull tape for pulling conductors through the conduit system. After installing conductors in conduit, perform conductor pull test. If a conductor cannot be freely pulled, make any needed alterations or repairs at no additional cost to the department. Perform insulation resistance tests in accordance with Item 620. Coordinate with the Engineer to witness the tests.
2. Leave 2 ft. minimum, 3 ft. maximum length for each conductor up to the splice in ground boxes. Leave 3 ft. minimum, 4 ft. maximum length of conductor in ground boxes when pulled through with no splice. Leave 1 ft. minimum, 1.5 ft. maximum length of conductor at enclosures, weatherheads and pole bases.
3. Make splices only in junction boxes, ground boxes, pole bases, or electrical enclosures and use only listed compression or screw type pressure connectors, terminal blocks, or split bolt connectors. Insulate splices with heavy wall heat shrink tubing or gel-filled insulating splice covers to provide a watertight seal. Overlap conductor insulation with heat shrink tubing a minimum of 2 in. past both sides of the splice. Where heat shrink tubing may not shrink sufficiently to provide a watertight seal around the individual conductors, prior to heating the tubing, increase the diameter of the conductor insulation using hot melt adhesive tape to provide a watertight seal between the individual conductors and the heat shrink tubing. Ensure the tape extends past the heat shrink tubing. Use hot melt adhesive tape to fill the gap and seal the ends of heat shrink tubing. Heat shrink tubing that appears to have been burned, or overheated, is considered defective and must be replaced.
4. Size and install gel-filled insulating splice covers according to manufacturer's specifications when used in place of heat shrink tubing.
5. Wire nuts with factory applied waterproof sealant may be used for 8 AWG or smaller conductors in above ground junction boxes, but not in pole bases or ground boxes. Install wire nuts in an upright position to prevent the accumulation of water.
6. Support conductors in illumination poles with a J-hook at the top of the pole.
7. When terminating conductors, remove the insulation and jacketing material without nicking the individual strands of the conductor. Conductors with nicked individual conductor strands or removed strands will be considered damaged.
8. Replace conductors and cables that are damaged beyond repair or that fail an insulation resistance test at no additional cost to the department.
9. Do not repair damaged conductors with duct tape, electrical tape, or wire nuts. Use only approved splicing methods.
10. Do not terminate more than one conductor under a single connector, unless the connector is rated for multiple conductors. Do not exceed the pressure connector's listing for maximum number and size of conductors allowed.
11. Install breakaway connectors on conductors bid under Item 620 whenever those conductors pass through a breakaway support device. Follow manufacturer's instructions when terminating conductors to breakaway connectors. Properly torque threaded connections. Proper terminations are critical to the safe operation of breakaway devices. Trim waterproofing boots on breakaway connectors to fit snugly around the conductor to ensure waterproof connection. Only one conductor may enter a single opening in a boot. Provide waterproof boots with the correct number of openings. Leave unused openings factory sealed. Use prequalified breakaway connectors as shown on the MPL.

12. Provide and install a separate stranded equipment grounding conductor (EGC) in all conduits that contain circuit wiring of 50 volts or more. Unless shown elsewhere, size the EGC to be the same size as the largest current carrying conductor contained in the conduit. Ensure all EGCs are bonded together at every accessible location. For traffic signal installations, provide a minimum size 8 AWG EGC. The EGC is paid for under Item 620.

## C. TEMPORARY WIRING

1. Install temporary conductors and electrical equipment in accordance with the NEC article "Temporary Installations" and Department standard sheets.
2. Provide a ground fault circuit interrupter (GFCI) for power outlets for portable electrical equipment, power tools, ice machines, ice storage bins and refrigerators located outdoors at grade. GFCI may be any one of the following: molded cord and plug set, receptacle, or circuit breaker type.
3. Use listed wire nuts with factory applied sealant for temporary wiring where approved.
4. Enclose conductor splices within a listed enclosure or ground box, or ensure the splices are more than 10 ft. above grade vertically and more than 5 ft. horizontally from any metal structure. Where installing temporary conductors in areas subject to vehicle traffic or mobile construction equipment, ensure the vertical clearance to ground is at least 18 ft. when measured at the lowest point. Ground messenger wires that support power conductors in conformance with the NEC.
5. Protect and when necessary repair any existing electrical conduits uncovered during the construction process in a timely manner and in conformance with the NEC.

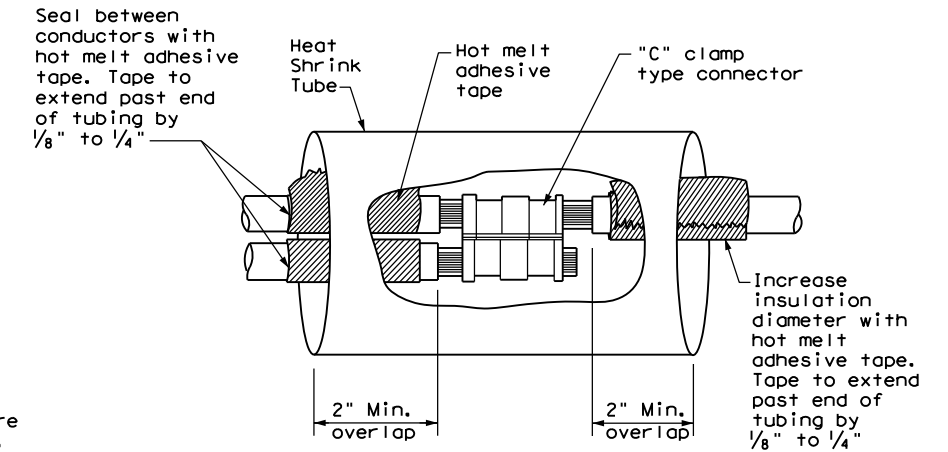

**SPLICE OPTION 1  
Compression Type**

## GROUND RODS & GROUNDING ELECTRODES

### A. MATERIAL INFORMATION

1. Provide and install a grounding electrode at electrical services. Provide ground rods according to DMS 11040 and the plans. Larger diameter or longer length rods may be called for in some specific locations, see the individual plans sheets. Concrete encased grounding electrodes may be called for in specific locations including electrical service, see individual plan sheets.

### B. CONSTRUCTION METHODS

1. Furnish auxiliary ground rods for lightning protection and install in soil, concrete, or both, as called for in the plans. For ground rods installed in concrete, ensure the connection of the conductor to the ground rod is readily accessible for inspection or repairs. For ground rods installed in soil, ensure that the upper end is between 2 to 4 in. below finished grade.
2. Do not place ground rods in the same drilled hole as a timber pole.
3. Install ground rods so the imprinted part number is at the upper end of the rod.
4. Remove all non-conductive coatings such as concrete splatter from the rod at the clamp location.
5. Route all conductors as short and straight as possible for connection to lightning protection ground rods. When a bend is required, ensure a minimum radius bend of four inches for these conductors.
6. Unless otherwise called for in the plans, protect grounding electrode conductors with non-metallic conduit. When protecting grounding electrode conductors with metal conduit, provide and install a grounding type bushing and properly sized bonding jumper on each end of the metal conduit.
7. Written authorization is required before installing a ground rod in a horizontal trench for rocky soil or a solid rock bottom.

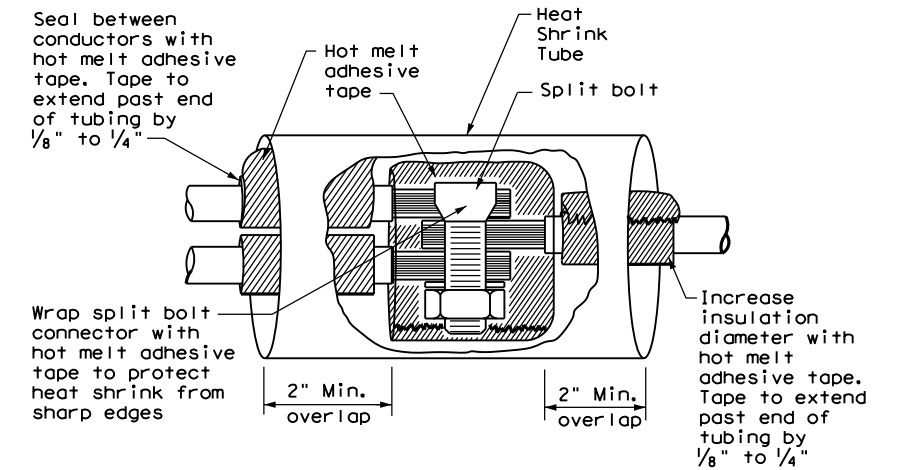

**SPLICE OPTION 2  
Split Bolt Type**

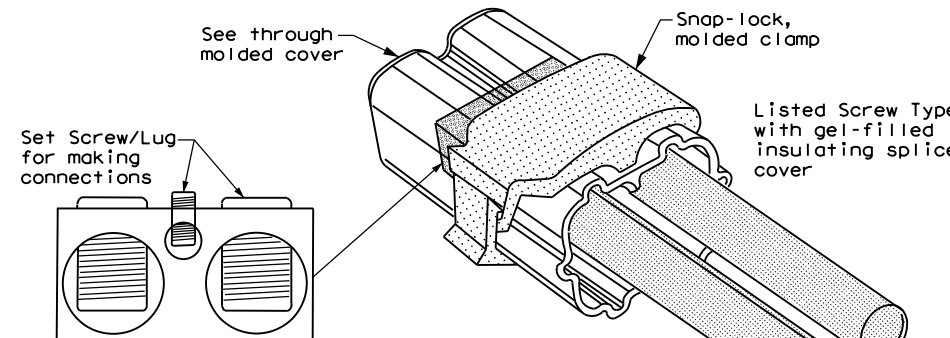

**SPLICE OPTION 3  
Listed Screw Type**

DISCLAIMER: The use of this standard is governed by the "Texas Engineering Practice Act". No warranty of any kind is made by TxDOT for any purpose whatsoever. TxDOT assumes no responsibility for the conversion of this standard to other formats or for incorrect results or damages resulting from its use.

DATE: 2/14/2024 3:24:13 PM  
U:\TRAFFIC PROJECTS\0918-00-392 Non-Site 9-24\Microstation Files\078 ED(3)-14.dgn

		<b>Texas Department of Transportation</b>		<b>Traffic Operations Division Standard</b>	
<h1>ELECTRICAL DETAILS CONDUCTORS</h1>					
<h2>ED(3) - 14</h2>					
FILE:	ed3-14.dgn	DN:	TxDOT	CK:	TxDOT
© TxDOT	October 2014	CONT:	SECT:	JOB:	HIGHWAY:
REVISIONS		0918	00	392	VA
DIST:	COUNTY:	SHEET NO.			
DAL	DALLAS, ETC.	78			

DISCLAIMER: The use of this standard is governed by the "Texas Engineering Practice Act". No warranty of any kind is made by TxDOT for any purpose whatsoever. TxDOT assumes no responsibility for the conversion of this standard to other formats or for incorrect results or damages resulting from its use.

DATE: 2/14/2024 3:24:49 PM  
 U:\TRAFFIC PROJECTS\0918-00-392 Non-Site 9-24\Microstation Files\079 ED(4)-14.dgn

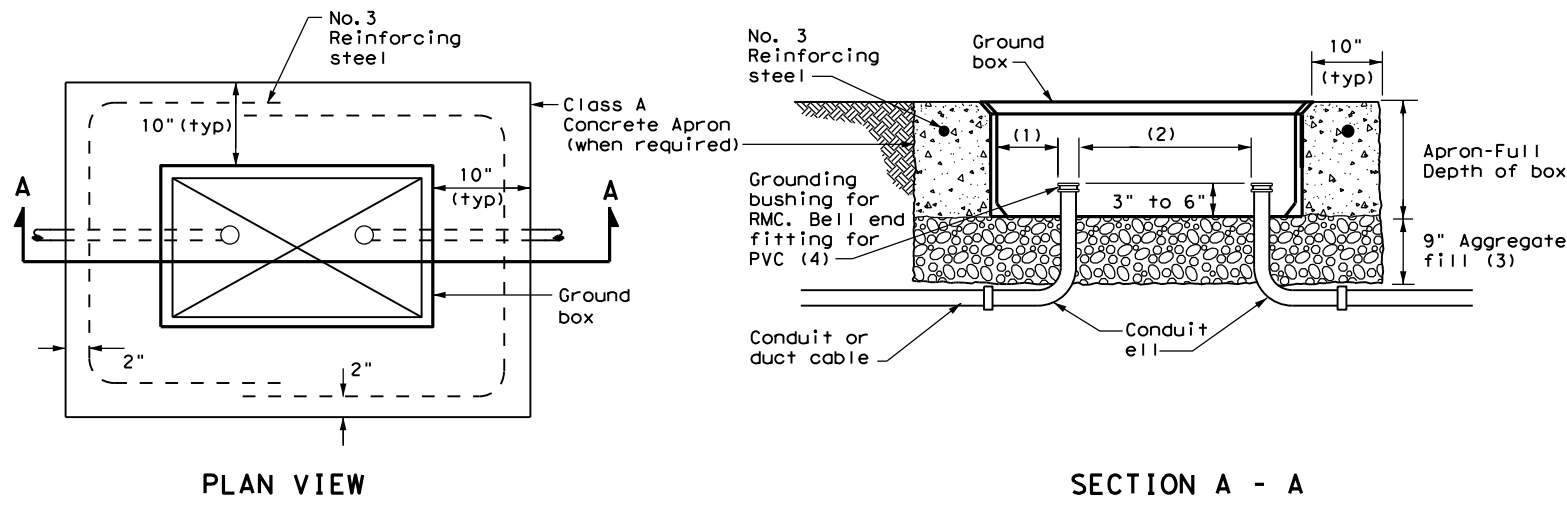

**APRON FOR GROUND BOX**

- (1) Uniformly space ends of conduits within the ground box. Position ends of conduits so that ground box walls do not interfere with the installation of grounding bushings or bell end fittings.
- (2) Maintain sufficient space between conduits to allow for proper installation of bushings.
- (3) Place aggregate under the box, not in the box. Aggregate should not encroach on the interior volume of the box.
- (4) Install a grounding bushing on the upper end of all RMC terminating in a ground box. Ground RMC elbows when any part of the elbow is less than 18 in. below the bottom of the ground box. Install a PVC bushing or bell end fitting on the upper end of all PVC conduits terminating in a ground box.

GROUND BOX DIMENSIONS	
TYPE	OUTSIDE DIMENSIONS (INCHES) (Width x Length X Depth)
A	12 X 23 X 11
B	12 X 23 X 22
C	16 X 29 X 11
D	16 X 29 X 22
E	12 X 23 X 17

GROUND BOX COVER DIMENSIONS								
TYPE	DIMENSIONS (INCHES)							
	H	I	J	K	L	M	N	P
A, B & E	23 1/4	23	13 3/4	13 1/2	9 7/8	5 1/8	1 3/8	2
C & D	30 1/2	30 1/4	17 1/2	17 1/4	13 1/4	6 3/4	1 3/8	2

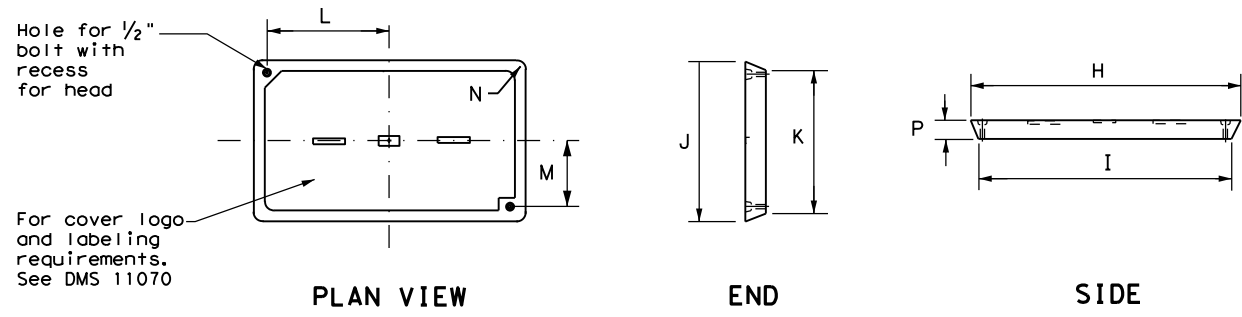

**GROUND BOX COVER**

**GROUND BOXES**

**A. MATERIALS**

- 1. Provide polymer concrete ground boxes measuring 16x30x24 in. (WxLxD) or smaller in accordance with Departmental Material Specification (DMS) 11070 "Ground Boxes" and Item 624 "Ground Boxes."
- 2. Provide Type A, B, C, D, and E ground boxes as shown in the plans, and as listed on the Material Producers List (MPL) on the Department web site under "Roadway Illumination and Electrical Supplies," Item 624.
- 3. Ensure ground box cover is correctly labeled in accordance with DMS 11070.
- 4. Provide larger ground boxes in accordance with Item 624 and as shown in the plans.

**B. CONSTRUCTION METHODS**

- 1. Remove all gravel and dirt from conduit. Cap all conduits prior to placing aggregate and setting ground box. Provide Grade 3 or 4 coarse aggregate as shown on Table 2 of Item 302 "Aggregates for Surface Treatments." Ensure aggregate bed is in place and at least 9 inches deep, prior to setting the ground box. Install ground box on top of aggregate.
- 2. Cast ground box aprons in place. Reinforcing steel may be field bent. Ensure the depth of concrete for the apron extends from finished grade to the top of the aggregate bed under the box. Ground box aprons, including concrete and reinforcing steel, are subsidiary to ground boxes when called for by descriptive code.
- 3. Keep bolt holes in the box clear of dirt. Bolt covers down when not working in ground boxes.
- 4. Install all conduits and ells in a neat and workmanlike manner. Uniformly space conduits so grounding bushings and bell end fittings can easily be installed.
- 5. Temporarily seal all conduits in the ground box until conductors are installed.
- 6. Permanently seal conduits immediately after the completion of conductor installation and pull tests. Permanently seal the ends of all conduits with duct seal, expandable foam, or other method as approved. Do not use duct tape as a permanent conduit sealant. Do not use silicone caulk as a sealant.
- 7. When a ground rod is present in a ground box, bond all equipment grounding conductors together and to the ground rod with listed connectors.
- 8. When a type B or D ground box is stacked to meet volume requirements, it is allowable to cut an appropriately sized hole for conduit entry in the side wall at least 18 inches below grade.
- 9. If an existing ground box in the contract has a metal cover, bond the cover to the equipment grounding conductor with a 3 ft. long stranded bonding jumper the same size as the grounding conductor. The bonding jumper is subsidiary to various bid items. Verify existing ground boxes with metal covers are shown on the plans, with notes fully describing the work required.
- 10. If other ground boxes with metal covers are within the project limits but are not part of the contract, the Engineer may direct the Contractor to bond the metal covers, identifying the specific boxes in writing. This work will be paid for separately.
- 11. Bond metal ground box covers to the grounding conductor with a tank ground type lug.

				Traffic Operations Division Standard	
<h2>ELECTRICAL DETAILS GROUND BOXES</h2>					
<h3>ED(4) - 14</h3>					
FILE:	ed4-14.dgn	DN:	TxDOT	CK:	TxDOT
© TxDOT	October 2014	CONT	SECT	JOB	HIGHWAY
REVISIONS		0918	00	392	VA
DIST	COUNTY	SHEET NO.			
DAL	DALLAS, ETC.	79			

**ELECTRICAL SERVICES NOTES**

- Provide new materials. Ensure installation and materials comply with the applicable provisions of the National Electrical Code (NEC) and National Electrical Manufacturers Association (NEMA) standards. Ensure material is Underwriters Laboratories (UL) listed. Provide and install electrical service conduits, conductors, disconnects, contactors, circuit breaker panels, and branch circuit breakers as shown on the Electrical Service Data chart in the plans. Faulty fabrication or poor workmanship in material, equipment, or installation is justification for rejection. Where manufacturers provide warranties and guarantees as a customary trade practice, furnish these to the State.
- Provide electrical services in accordance with Electrical Details standard sheets, Departmental Material Specification (DMS) 11080 "Electrical Services," DMS 11081 "Electrical Services-Type A," DMS 11082 "Electrical Services-Type C," DMS 11083 "Electrical Services-Type D," DMS 11084 "Electrical Services-Type T," DMS 11085 "Electrical Services-Pedestal (PS)", and Item 628 "Electrical Services" of the Standard Specifications. Provide electrical service types A, C, and D, as listed on the Material Producers List (MPL) on the Department web site under "Roadway Illumination and Electrical Supplies," Item 628. Provide other service types as detailed on the plans.
- Provide all work, materials, services, and any incidentals needed to install a complete electrical service as specified in the plans.
- Coordinate with the Engineer and the utility provider for metering and compliance with utility requirements. Primary line extensions, connection charges, meter charges, and other charges by the utility company to provide power to the location are paid for in accordance with Item 628. Get approval for the costs associated with these charges prior to engaging the utility company to do the work. Consult with the utility provider to determine costs and requirements, and coordinate the work as approved.
- The enclosure manufacturer will provide Master Lock Type 2 with brass tumblers keyed #2195 for all custom electrical enclosures. Installing Contractor is to provide Master Lock #2195 Type 2 with brass tumblers for "off the shelf" enclosures. Master Lock #2195 keys and locks become property of the State. Unless otherwise approved, do not energize electrical service equipment until locks are installed.
- Enclosures with external disconnects that de-energize all equipment inside the enclosure do not need a dead front trim. Protect incoming line terminations from incidental contact as required by the NEC.
- When galvanized is specified for nuts, screws, bolts or miscellaneous hardware, stainless steel may be used.
- Provide wiring and electrical components rated for 75°C. Provide red, black, and white colored XHHW service entrance conductors of minimum size 6 American Wire Gauge (AWG). Identify size 6 AWG conductors by continuous color jacket. Identify electrical conductors sized 4 AWG and larger by continuous color jacket or by colored tape. Mark at least 6 inches of the conductor's insulation with half laps of colored tape, when identifying conductors. Ensure each service entrance conductor exits through a separately bushed non-metallic opening in the weatherhead. The lengths of the conductors outside the weatherhead are to be 12 inches minimum, 18 inches maximum, or as required by utility.
- All electrical service conduit and conductors attached to the electrical service including the riser or the elbow below ground are subsidiary to the electrical service. For an underground utility feed, all service conduit and conductors after the elbow, including service conduit and conductors for the utility pole riser when furnished by the Contractor, will be paid for separately.
- Provide rigid metal conduit (RMC) for all conduits on service, except for the 1/2 in. PVC conduit containing the electrical service grounding electrode conductor. Size the service entrance conduit as shown in the plans. Ensure conduit for branch circuit entry to enclosure is the same size as that shown on the layout sheets for branch circuit conduit. Extend all rigid metal conduits a minimum of 6 inches underground and then couple to the type and schedule of the conduit shown on the layout for that particular branch circuit. Install a grounding bushing on the RMC where it terminates in the service enclosure.
- Use of liquidtight flexible metal conduit (LFMC) is allowed between the meter and service enclosure when they are mounted 90 to 180 degrees to each other. Size the LFMC the same size as service entrance conduit. LFMC must not exceed 3 feet in length. Strap LFMC within 1 foot of each end. LFMC less than 12 inches in length need not be strapped. Each end of LFMC must have a grounding bushing or be terminated with a grounding fitting. The LFMC must contain a grounded (neutral) conductor. Ensure any bend in LFMC never exceeds 180 degrees. A pull test is required on all installed conductors, with at least six inches of free conductor movement demonstrated to the satisfaction of the Engineer.
- Ensure all mounting hardware and installation details of services conform to utility company specifications.
- For all electrical service enclosures listed under Item 628 on the MPL, the UL 508 enclosure manufacturers will prepare and submit a schematic drawing unique to each service. Before shipment to the job site, place the applicable laminated schematic drawings and the laminated plan sheet showing the electrical service data chart used to build the enclosure in the enclosure's data pocket. The installing contractor will copy and laminate the actual project plan sheets detailing all equipment and branch circuits supplied by that service. The laminated plan sheets are to be placed in the service enclosure's document pocket. Reduce 11 in. x 17 in. plan sheets to 8 1/2 in. x 11 in. before laminating. If the installation differs from the plan sheets, the installing contractor is to redline plan sheets before laminating.
- When providing an "Off The Shelf" Type D or Type T service, provide laminated plan sheets detailing equipment and branch circuits supplied by that service. Reduce 11 in. x 17 in. plan sheets to 8 1/2 in. x 11 in. before laminating. Deliver these drawings before completion of the work to the Engineer, instead of placing in enclosure that has no door pocket.
- Do not install conduit in the back wall of a service enclosure where it would penetrate the equipment mounting panel inside the enclosure. Provide grounding bushings on all metal conduits, and terminate bonding jumpers to grounding bus. Grounding bushings are not required when the end of the metal conduit is fitted with a conduit sealing hub or threaded boss, such as a meter base hub.

**SERVICE ASSEMBLY ENCLOSURE**

- Provide threaded hub for all conduit entries into the top of enclosure.
- Type galvanized steel (GS) enclosures may be used for Type C panelboards and for Type D and T services that do not use an enclosure mounted photoceII or lighting contactor. Provide GS enclosures in accordance with DMS 11080, 11082, 11083, and 11084.
- Provide aluminum (AL) and stainless steel (SS) enclosures for Types A, C, and D in accordance with DMS 11080, 11081, 11082, 11083, and 11084. Do not paint stainless steel.
- Provide pedestal service (PS) enclosures in accordance with ED(9) and DMS 11080 and 11085. Do not provide GS pedestal services. If GS is shown in the PS descriptive code, provide an AL enclosure.

**MAIN DISCONNECT & BRANCH CIRCUIT BREAKERS**

- Field drill flange-mounted remote operator handle if needed, to ensure handle is lockable in both the "On" and "Off" positions.
- When the utility company provides a transformer larger than 50 KVA, verify that the available fault current is less than the circuit breaker's ampere interrupting capacity (AIC) rating and provide documentation from the electric utility provider to the Engineer.

**PHOTOELECTRIC CONTROL**

- Provide photocell as listed on the MPL. Move, adjust, or shield the photocell from stray or ambient night time light to ensure proper operation. Mount photocell facing north when practical. Mount top of pole photocells as shown on Top Mounted Photocell Detail.

* ELECTRICAL SERVICE DATA												
Elec. Service ID	Plan Sheet Number	Electrical Service Description	Service Conduit *xSize	Service Conductors No./Size	Safety Switch Amps	Main Ckt. Bkr. Pole/Amps	Two-Pole Contractor Amps	Panelbd/ Loadcenter Amp Rating	Branch Circuit ID	Branch Ckt. Bkr. Pole/Amps	Branch Circuit Amps	KVA Load
SB 183	289	ELC SRV TY A 240/480 100(SS)AL(E)SF(U)	2"	3/#2	100	2P/100	100	N/A	Lighting NB	2P/40	26	28.1
									Lighting SB	2P/40	25	
									Underpass	1P/20	15	
NB Access	30	ELC SRV TY D 120/240 060(NS)SS(E)TS(O)	1 1/4"	3/#6	N/A	2P/60		100	Sig. Controller	1P/30	23	5.3
							30		Luminares	2P/20	9	
									CCTV	1P/20	3	
2nd & Main	58	ELC SRV TY T 120/240 000(NS)GS(N)SP(O)	1 1/4"	3/#6	N/A	N/A	N/A	70	Flashing Beacon 1	1P/20	4	1.0
									Flashing Beacon 2	1P/20	4	

\* Example only, not for construction. All new electrical services must have electrical service data chart specific to that service as shown in the plans.  
 \*\* Verify service conduit size with utility. Size may change due to utility meter requirements. Ensure conduit size meets the National Electrical Code.

**EXPLANATION OF ELECTRICAL SERVICE DESCRIPTIVE CODE**

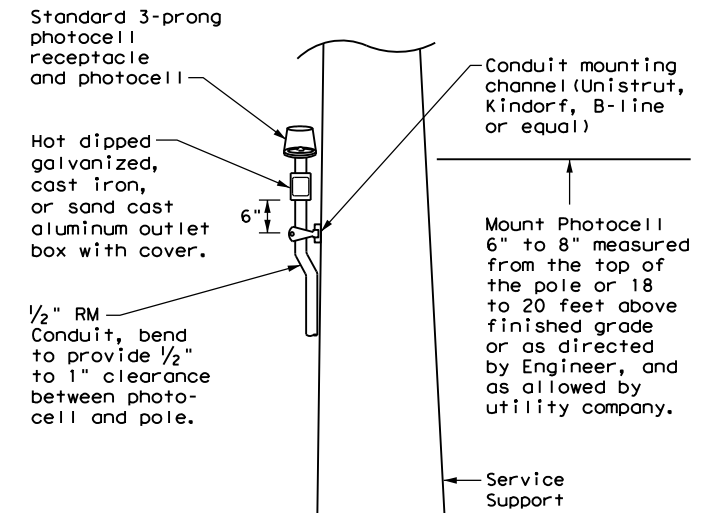
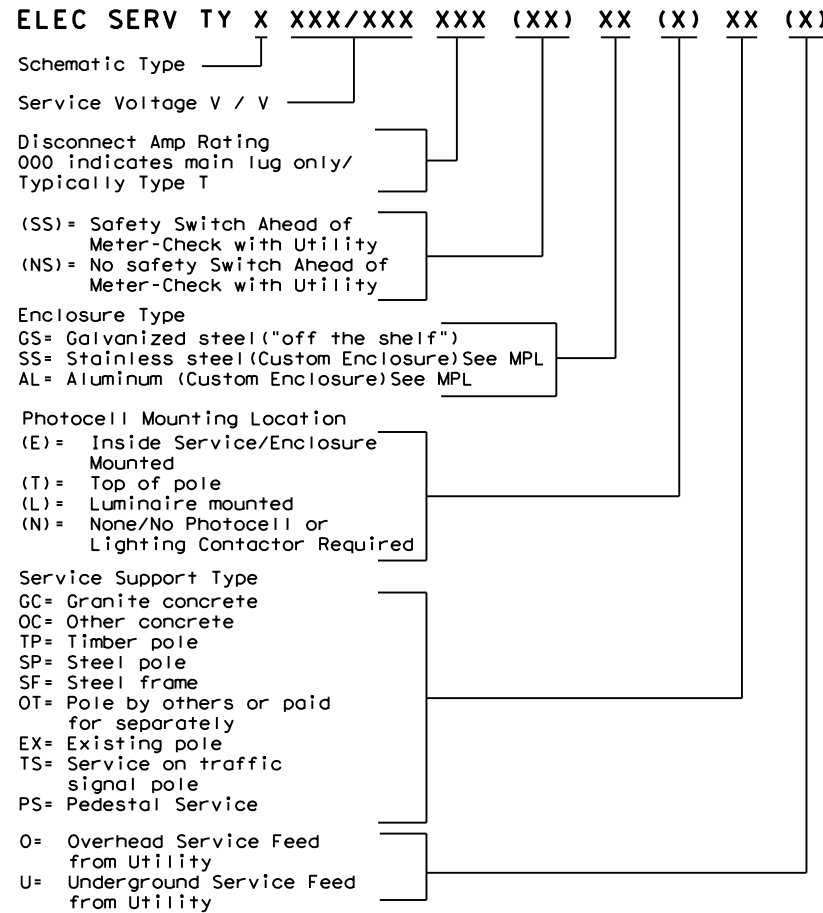

**TOP MOUNTED PHOTOCELL**

Install conduit strap maximum 3 feet from box. 5 foot maximum spacing between straps supporting conduit.

<p><b>ELECTRICAL DETAILS SERVICE NOTES &amp; DATA</b></p> <p><b>ED(5) - 14</b></p>			
FILE: ed5-14.dgn	DN: TxDOT	CK: TxDOT	DW: TxDOT
© TxDOT October 2014	CONT	SECT	JOB
REVISIONS	091800	392	VA
DIST	COUNTY	SHEET NO.	
DAL	DALLAS, ETC.	80	

DATE: 2/14/2024 3:25:29 PM  
 U:\TRAFFIC PROJECTS\0918-00-392\_Non-Site 9-24\Microstation Files\080 ED(5)-14.dgn  
 The use of this standard is governed by the "Texas Engineering Practice Act". No warranty of any kind is made by TxDOT for any purpose whatsoever. TxDOT assumes no responsibility for the conversion of this standard to other formats or for incorrect results or damages resulting from its use.



DISCLAIMER: The use of this standard is governed by the "Texas Engineering Practice Act". No warranty of any kind is made by TxDOT for any purpose whatsoever. TxDOT assumes no responsibility for the conversion of this standard to other formats or for incorrect results or damages resulting from its use.

DATE: 2/14/2024 3:26:17 PM  
 U:\TRAFFIC PROJECTS\0918-00-392 Non-Site 9-24\Microstation Files\081 ED(6)-14.dgn

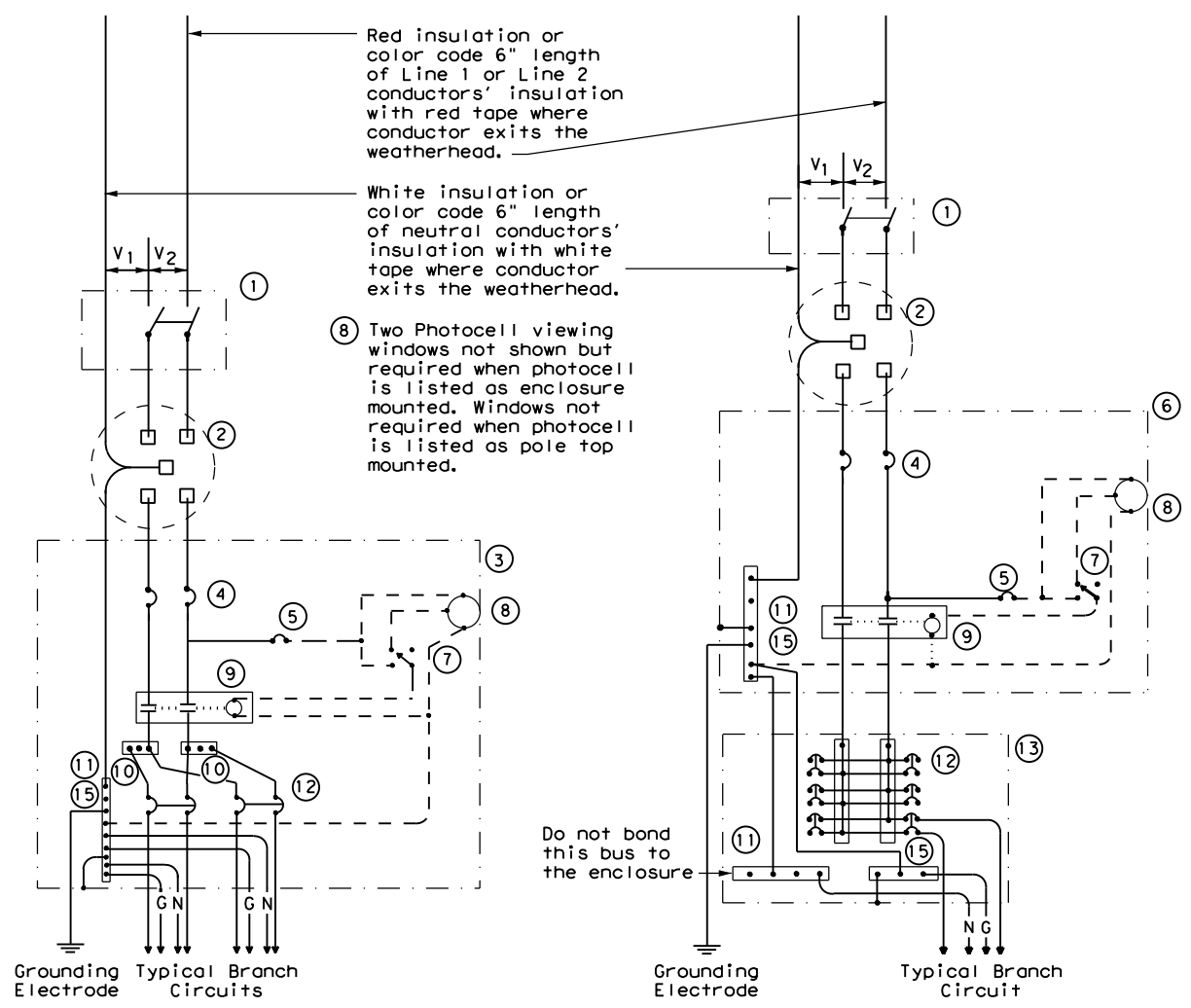

**SCHEMATIC TYPE A**  
THREE WIRE

**SCHEMATIC TYPE C**  
THREE WIRE

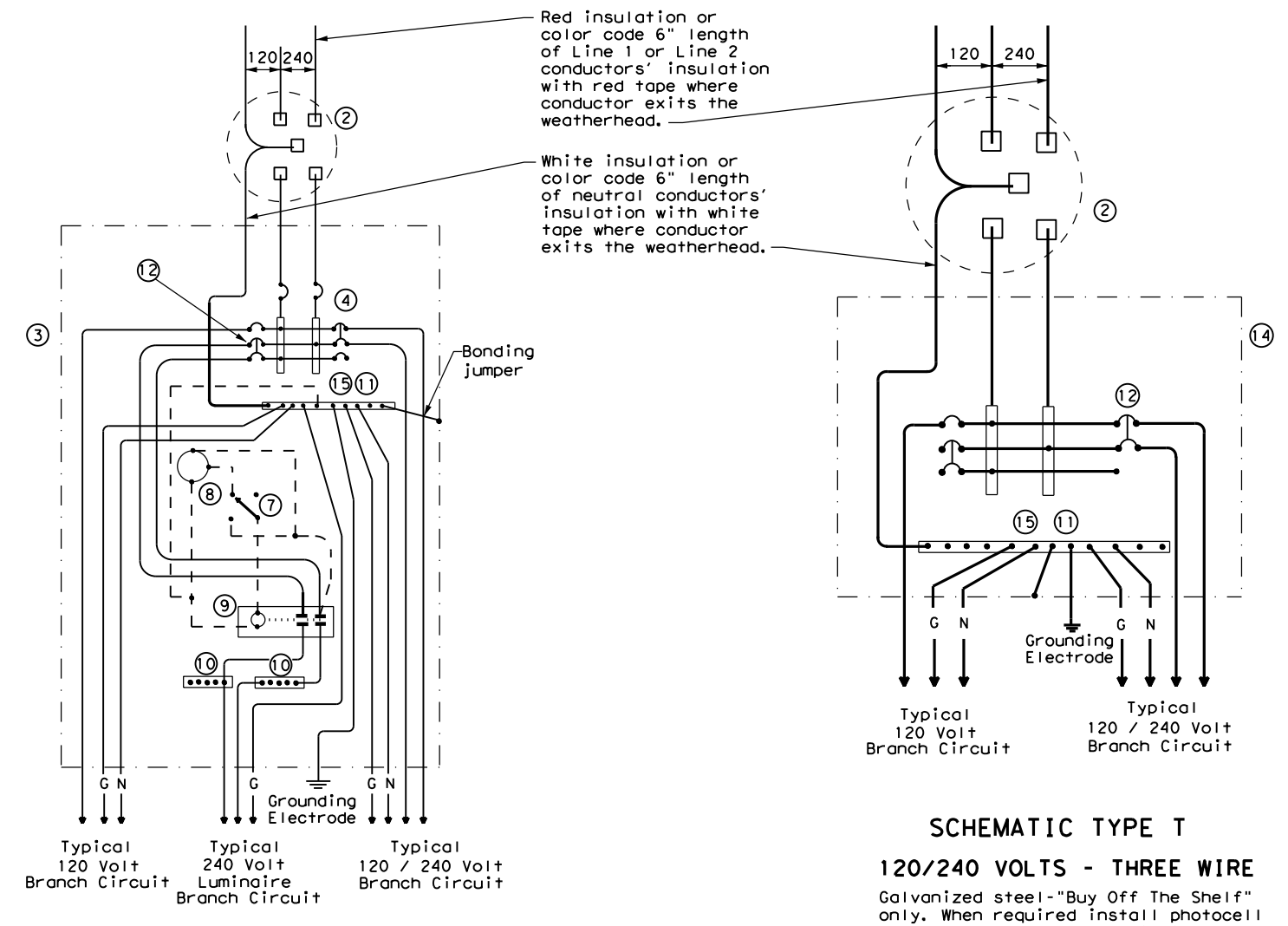

**SCHEMATIC TYPE D - CUSTOM**  
120/240 VOLTS - THREE WIRE

**SCHEMATIC TYPE T**  
120/240 VOLTS - THREE WIRE

Galvanized steel - "Buy Off The Shelf" only. When required install photocell top of the pole or on luminaire only, no lighting contractor will be installed.

WIRING LEGEND	
—	Power Wiring
- - - -	Control Wiring
—N—	Neutral Conductor
—G—	Equipment grounding conductor-always required

SCHEMATIC LEGEND	
1	Safety Switch (when required)
2	Meter (when required-verify with electric utility provider)
3	Service Assembly Enclosure
4	Main Disconnect Breaker (See Electrical Service Data)
5	Circuit Breaker, 15 Amp (Control Circuit)
6	Auxiliary Enclosure
7	Control Station ("H-O-A" Switch)
8	Photo Electric Control (enclosure-mounted shown)
9	Lighting Contactor
10	Power Distribution Terminal Blocks
11	Neutral Bus
12	Branch Circuit Breaker (See Electrical Service Data)
13	Separate Circuit Breaker Panelboard
14	Load Center
15	Ground Bus

				Traffic Operations Division Standard	
<b>ELECTRICAL DETAILS SERVICE ENCLOSURE AND NOTES</b>					
<b>ED(6) - 14</b>					
FILE:	ed6-14.dgn	DN:	TxDOT	CK:	TxDOT
© TxDOT	October 2014	CONT	SECT	JOB	HIGHWAY
REVISIONS		0918	00	392	VA
DIST	COUNTY	SHEET NO.			
DAL	DALLAS, ETC.	81			

DISCLAIMER: The use of this standard is governed by the "Texas Engineering Practice Act". No warranty of any kind is made by TxDOT for any purpose whatsoever. TxDOT assumes no responsibility for the conversion of this standard to other formats or for incorrect results or damages resulting from its use.

DATE: 2/14/2024 3:27:03 PM  
 U:\TRAFFIC PROJECTS\0918-00-392 Non-Site 9-24\Microstation Files\082 ED(7)-14.dgn

**SUPPORT TYPE STEEL POLE (SP) AND STEEL FRAME (SF)**

1. Provide steel pole and steel frame supports as per TxDOT Departmental Material Specification (DMS)11080 "Electrical Services." Mount all equipment and conduit on 12 gauge galvanized steel or stainless steel channel strut, 1 1/2 in. or 1 3/8 in. wide by 1 in. up to 3 3/4 in. deep Unistrut, Kindorf, B-line or equal. Bolt or weld all channel and hardware to vertical members as approved. Do not stack channel. File smooth and paint field cut ends of all channel with zinc-rich paint before installing.
2. Provide poles for overhead service with an eyebolt or similar fitting for attachment of the service drop to the pole in conformance with the electric utility provider's specifications.
3. Provide and install galvanized 3/4 in. x 18 in. x 4 in. (dia. x length x hook length) anchor bolts for underground service supports. Provide and install galvanized 3/4 in. x 56 in. x 4 in. anchor bolts for overhead service supports. Ensure anchor bolts have 3 in of thread, with 3 1/4 in. to 3 1/2 in. of the exposed anchor bolt projecting above finished foundation. Provide and install leveling nuts for all anchor bolts.
4. Bond one of the anchor bolts to the rebar cage with 6 AWG bare stranded copper conductor. Use listed mechanical connectors rated for embedment in concrete. See Inset B.
5. Furnish and install rigid metallic ellis in all steel pole and steel frame foundations for all conduits entering the service from underground.
6. Use class C concrete for foundations. Ensure reinforcing steel is Grade 60 with 3" of unobstructed concrete cover.
7. Drill and tap steel poles and frames for 1/2 in. X 13 UNC tank ground fitting. For steel pole service supports, provide and install tank ground fitting 4 in. to 6 in. below electrical service enclosure. Provide properly sized hole through the bottom of the enclosure for the service grounding electrode conductor. Ensure electrical service grounding electrode conductor is as short and straight as possible from the enclosure to the tank ground fitting. For steel frame service supports, provide and install tank ground fitting on steel frame post. Install service grounding electrode conductor in a non-metallic conduit or tubing from the enclosure to the steel frame post. Connect electrical service grounding electrode conductor to the tank ground fitting. See steel frame and steel pole details and Inset A for more information. Size service entrance conduit and branch circuit conduit as shown in the plans. For underground conduit runs from the electrical service, extend RMC from the service enclosure to an RMC elbow, and then connect the schedule type and size of conduit shown in the plans. Provide and install grounding bushings where RMC terminates in the enclosure. Grounding bushings are not required when RMC is fitted into a sealing hub or threaded boss.
8. If Steel pole or frame is painted, bond each separate painted piece with a bonding jumper attached to a tapped hole.
9. Provide 1/4" - 20 machine screws for bonding. Do not use sheet metal screws. Remove all non-conductive material at contact points. Terminate bonding jumpers with listed devices. Install minimum size 6 AWG stranded copper bonding jumpers. Make up all threaded bonding connections wrench tight.
10. Avoid contact of the service drop and service entrance conductors with the metal pole to prevent abrasion of the insulated conductors.
11. Shop drawings are not required for service support structure unless specifically stated elsewhere or directed by the Engineer.

White insulation or color code 6" of neutral conductor's insulation with white tape where conductor exits weatherhead.  
 Red insulation or color code 6" length of Line 1 or Line 2 conductor's insulation with red tape where conductor exits the weatherhead. Conductor slack length, 12" min., 18" max.

2" to 6" 4" (typ.)  
 RMC  
 Service Enclosure  
 Inset A  
 Channel bracket or other arrangement approved by the Engineer. (Kindorf, Unistrut, B-line or equal.)  
 Meter  
 Safety Switch  
 Inset B  
 60" TYP.  
 2"  
 Class "C" concrete  
 RMC  
 PVC  
 18" Min.  
 24 Dia. x 60" depth foundation 4-#5 reinforcing bars and #2 spiral (typ.) at 6" pitch

WITH SAFETY SWITCH  
 WITHOUT SAFETY SWITCH  
**SERVICE SUPPORT TYPE SP (O) - OVERHEAD SERVICE**

Drill, tap, and thread 1/2" X 13 UNC. Install tank ground fitting, connect electrical service grounding electrode conductor. See Note 7.

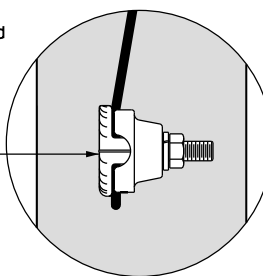

FRONT VIEW  
 INSET A

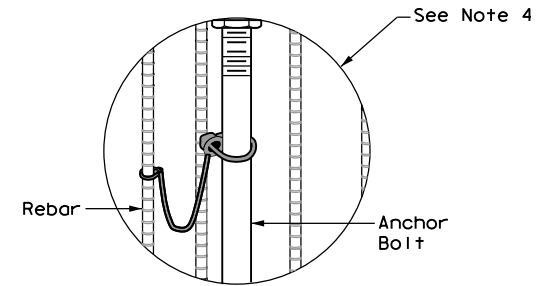

INSET B

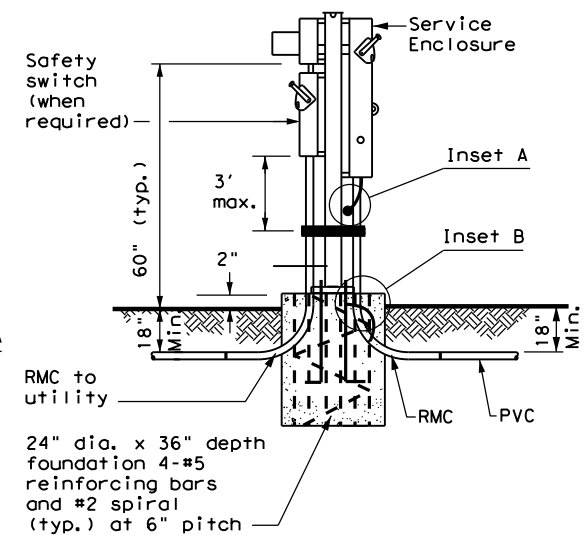

WITH SAFETY SWITCH  
 WITHOUT SAFETY SWITCH  
**SERVICE SUPPORT TYPE SP(U) - UNDERGROUND SERVICE**

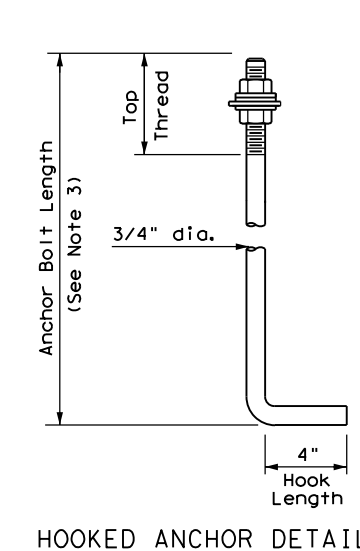

HOOKED ANCHOR DETAIL

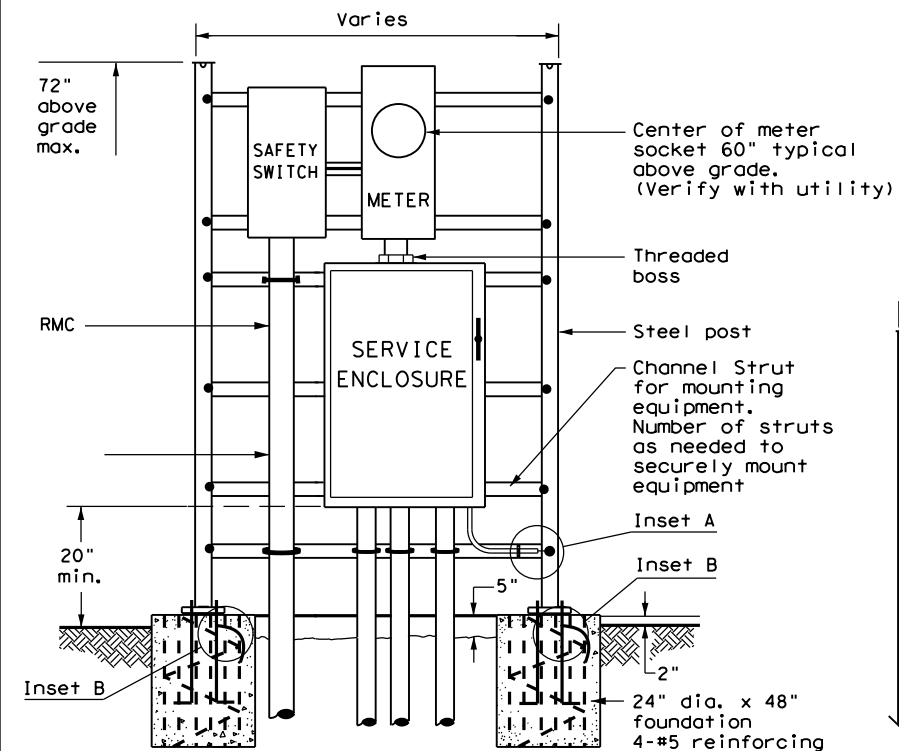

WITH SAFETY SWITCH  
 WITHOUT SAFETY SWITCH  
**SERVICE SUPPORT TYPE SF(U) - UNDERGROUND SERVICE**

Drill, top, and thread 1/2" X 13 UNC. Install tank ground fitting, connect electrical service grounding electrode conductor. See Note 7.

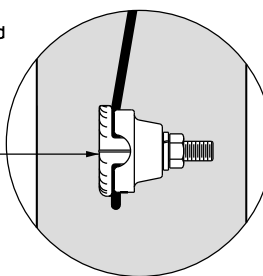

FRONT VIEW  
 INSET A

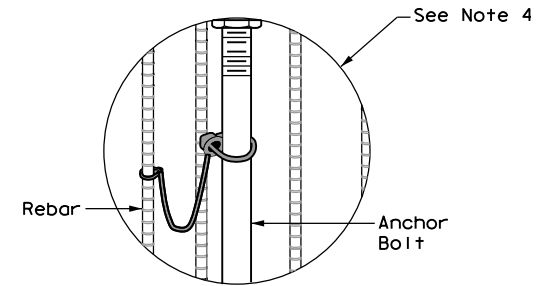

INSET B

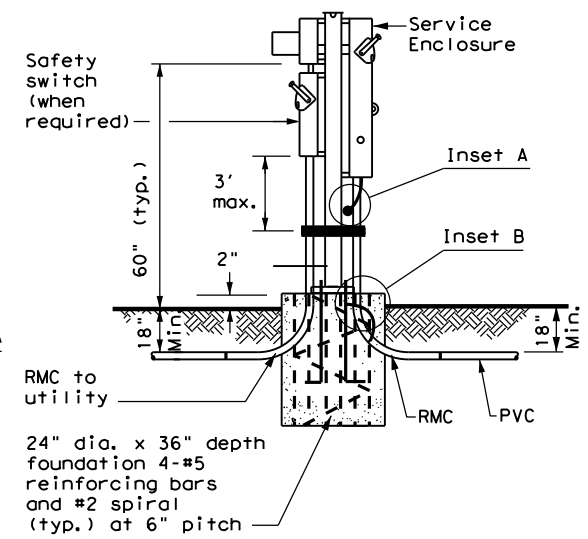

WITH SAFETY SWITCH  
 WITHOUT SAFETY SWITCH  
**SERVICE SUPPORT TYPE SP(U) - UNDERGROUND SERVICE**

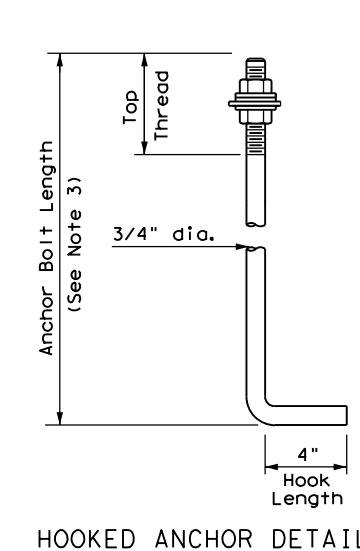

HOOKED ANCHOR DETAIL

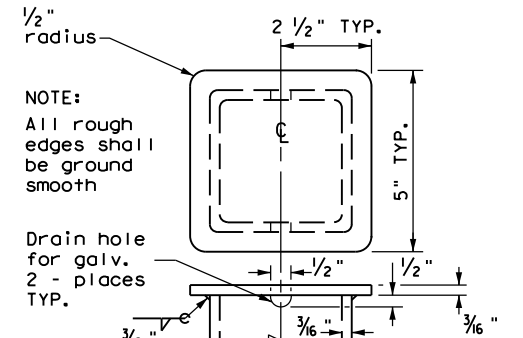

**POLE TOP PLATE**

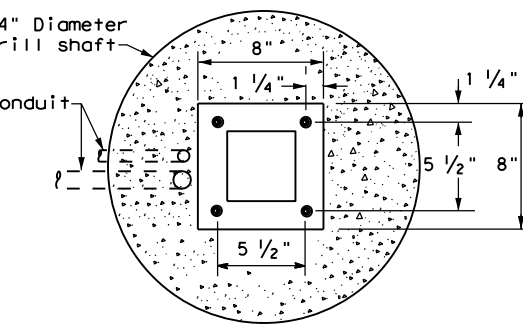

**BASE PLATE DETAIL**

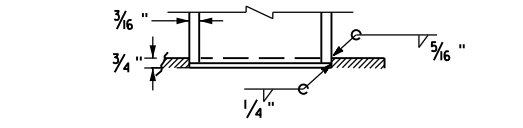

**BOTTOM OF POLE**

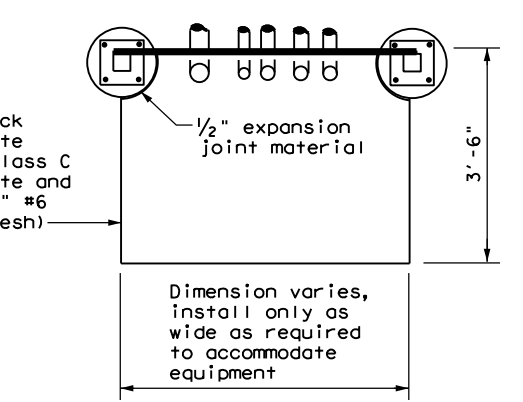

**SERVICE SUPPORT TYPE SF & SP**

**TOP VIEW**  
**SERVICE SUPPORT TYPE SF (O) & SF (U)**

Texas Department of Transportation		Traffic Operations Division Standard	
<b>ELECTRICAL DETAILS</b>			
<b>SERVICE SUPPORT</b>			
<b>TYPES SF &amp; SP</b>			
<b>ED(7)-14</b>			
FILE: ed7-14.dgn	DN: TxDOT	CK: TxDOT	DW: TxDOT
© TxDOT October 2014	CONT	SECT	JOB
REVISIONS	0918 00	392	VA
DIST	COUNTY	SHEET NO.	
DAL	DALLAS, ETC.	82	

DISCLAIMER: The use of this standard is governed by the "Texas Engineering Practice Act". No warranty of any kind is made by TxDOT for any purpose whatsoever. TxDOT assumes no responsibility for the conversion of this standard to other formats or for incorrect results or damages resulting from its use.

DATE: 2/14/2024 3:28:32 PM  
 U:\TRAFFIC PROJECTS\0918-00-392 Non-Site 9-24\Microstation Files\083 ED(8)-14.dgn

**TRAFFIC SIGNAL NOTES**

1. Do not pass luminaire conductors through the signal controller cabinet.
2. Include an equipment grounding conductor in all conduits throughout the electrical system. Bond all exposed metal parts to the grounding conductor.
3. Provide roadway luminaires, when required, in accordance with the material and construction sections of Item 610, "Roadway Illumination Assemblies," except for performance testing of luminaires. Test installed roadway luminaires for proper operation as a part of the associated traffic signal system test.
4. If internally illuminated street name signs are approved for use, ground the fixture to the pole with a 12 AWG green XHHW conductor.
5. Bond anchor bolts to rebar cage in two locations using #3 bars or 6 AWG stranded copper conductors. Use listed mechanical connectors rated for embedment in concrete. See TxDOT standard TS-FD for further details.
6. Drill and tap signal poles for 1/2 in. X 13 UNC tank ground fitting. Provide and install tank ground fitting 4 in. to 6 in. directly below electrical service enclosure. Provide properly sized hole through the bottom of the enclosure for the service grounding electrode conductor. Connect the electrical service grounding electrode conductor to the tank ground fitting. Ensure electrical service grounding electrode conductor is as short and straight as possible from the enclosure to the tank ground fitting. See Inset A detail for further information. Size service entrance conduit and branch circuit conduit as shown in the plans.
7. Mount electrical service enclosure and meter to signal pole with stainless steel bands. Ensure bands are a minimum width of 3/4 in. Secure enclosures to bands using two-bolt brackets. Install brackets near top and bottom of each enclosure. Install properly sized stainless steel washers on each bolt in the enclosure. Band or drill and tap properly sized stand-off straps to signal pole for attaching conduit.
8. Conduct pull tests and insulation resistance tests on all illumination and power conductors as required in Item 620 "Electrical Conductors" and ED(3). To prevent electronics damage, do not conduct insulation resistance tests on traffic signal cables after termination.
9. Lock all enclosures and bolt down all ground box covers before applying power to the signal installation.
10. Terminate conduits entering the top of enclosures with a conduit-sealing hub or threaded boss such as meter hub. Install a grounding bushing on all metal conduits not connected to conduit-sealing hub or threaded boss. Bond the grounding bushing to the ground bus with a bonding jumper. Seal all conduits entering enclosures with duct seal or expanding foam. Do not use silicone to seal conduit ends.
11. For all conduits, ensure the burial depth is a minimum of 18". Ensure the minimum burial depth for conduit placed under a roadway is 24".

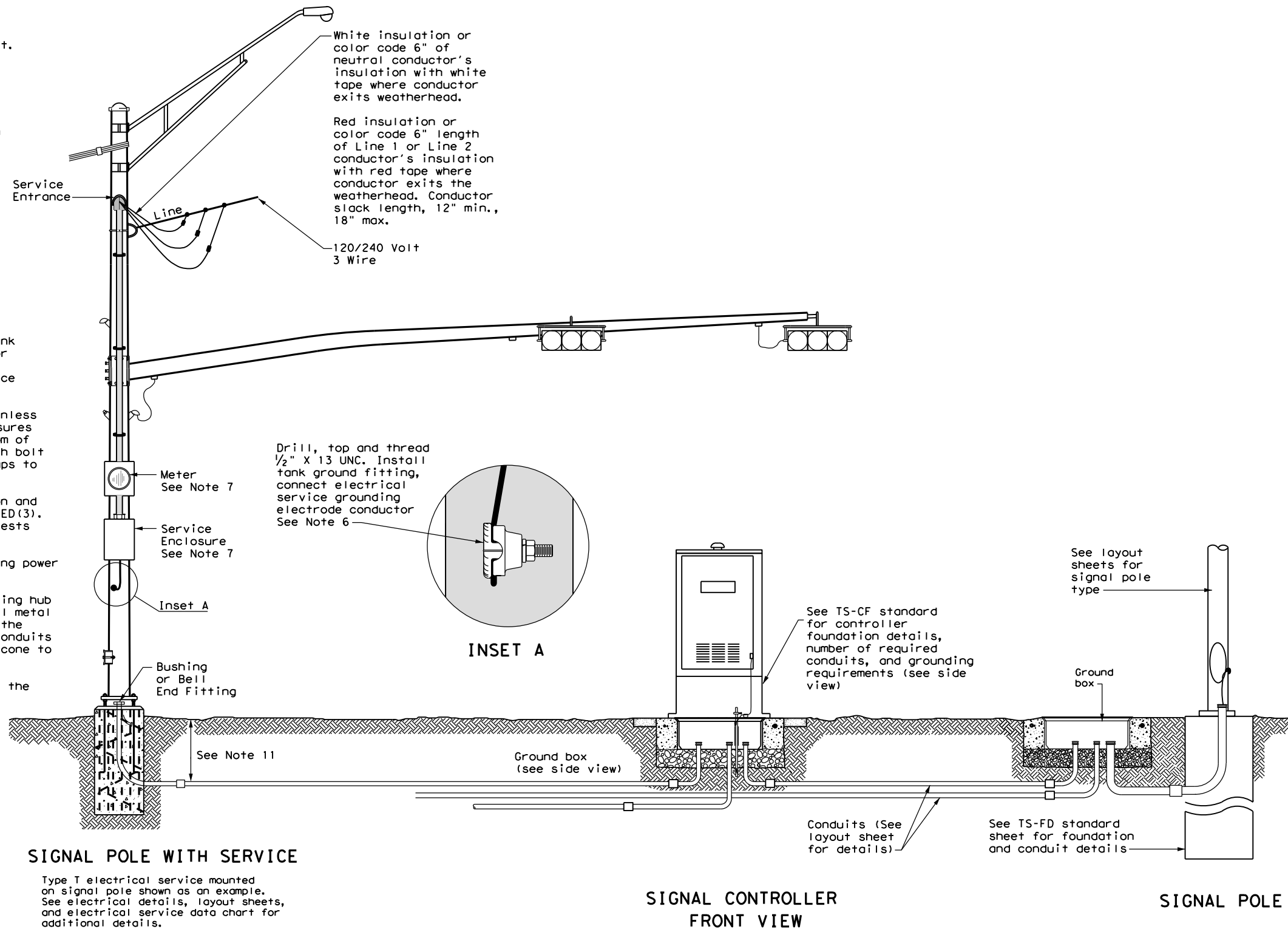

**SIGNAL POLE WITH SERVICE**

Type T electrical service mounted on signal pole shown as an example. See electrical details, layout sheets, and electrical service data chart for additional details.

**SIGNAL CONTROLLER FRONT VIEW**

**SIGNAL POLE**

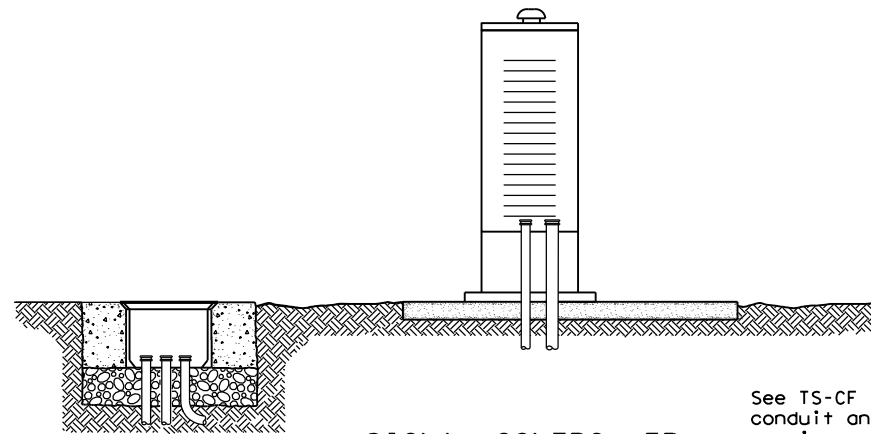

**SIGNAL CONTROLLER SIDE VIEW**

See TS-CF standard for conduit and grounding requirements. See layout sheets for ground box locations and any additional conduits that are required.

		<b>Texas Department of Transportation</b>		<b>Traffic Operations Division Standard</b>	
<b>ELECTRICAL DETAILS          TYPICAL TRAFFIC SIGNAL          SYSTEM DETAILS</b>					
<b>ED(8) - 14</b>					
FILE:	ed8-14.dgn	DN:	TxDOT	CK:	TxDOT
© TxDOT	October 2014	CONT	SECT	JOB	HIGHWAY
REVISIONS		0918	00	392	VA
DIST	COUNTY	SHEET NO.			
DAL	DALLAS, ETC.	83			

DISCLAIMER: The use of this standard is governed by the "Texas Engineering Practice Act". No warranty of any kind is made by TxDOT for any purpose whatsoever. TxDOT assumes no responsibility for the conversion of this standard to other formats or for incorrect results or damages resulting from its use.

DATE: 2/14/2024 3:28:57 PM  
 U:\TRAFFIC PROJECTS\0918-00-392 Non-Site 9-24\Microstation Files\084 ED(9)-14.dgn

**PEDESTAL SERVICE NOTES**

1. Manufacture pedestal electrical services in accordance with Departmental Material Specifications (DMS) 11080 "Electrical Services", 11085 "Electrical Services-Pedestal (PS)" and Item 628 "Electrical Services." Provide pedestal electrical services as listed on the Material Producers List (MPL) on the Department's web site under "Roadway Illumination and Electrical Supplies," Item 628. Ensure all mounting hardware and installation details of services meet utility company specifications. Contact the local utility company for approval of pedestal details prior to installing the electrical pedestal service. Submit any changes required by the utility company prior to manufacturing the pedestal enclosure.
2. When a meter socket is required, provide a socket with a minimum 100 amp rating that complies with local utility requirements.
3. Provide Class A or C concrete for pedestal service foundations in accordance with Item 420, "Concrete Substructures," except that concrete will not be paid for directly but is considered subsidiary to Item 628.
4. Provide #4 reinforcing steel for foundations in accordance with Item 440, "Reinforcement for Concrete."
5. Install 1/2 in. X 2 1/16 in. minimum length concrete single expansion type anchors for mounting pedestal enclosure to foundation. Anchor location to match mounting holes in each corner of enclosure. Secure each of the four corners of the pedestal enclosure to the anchors in the foundation with a 1/2 in. galvanized or stainless steel machine thread bolt, a properly sized locknut and a flat washer.
6. Finish top of concrete foundation in a neat and workmanlike manner. If leveling washers are used, ensure no more than 1/8 in. gap at any corner. Do not exceed a maximum dip or rise in the foundation of 1/8 in. per foot. When properly installed, ensure the top of the service enclosure is level front to back and side to side within 1/4 in. Repair rocking or movement of the service enclosure at no additional cost to the department.
7. Do not use liquidtight flexible metal conduit (LFMC) on pedestal type services.
8. Ensure all elbows in the foundation are sized as per utility provider's conduit requirements for underground conduit and feeders. PVC extensions may be installed provided the ends of the rigid metal conduits are more than 2 in. below the top of the concrete foundation. Where extension conduits are metal, grounding bushings must be installed with a bonding jumper properly terminated.

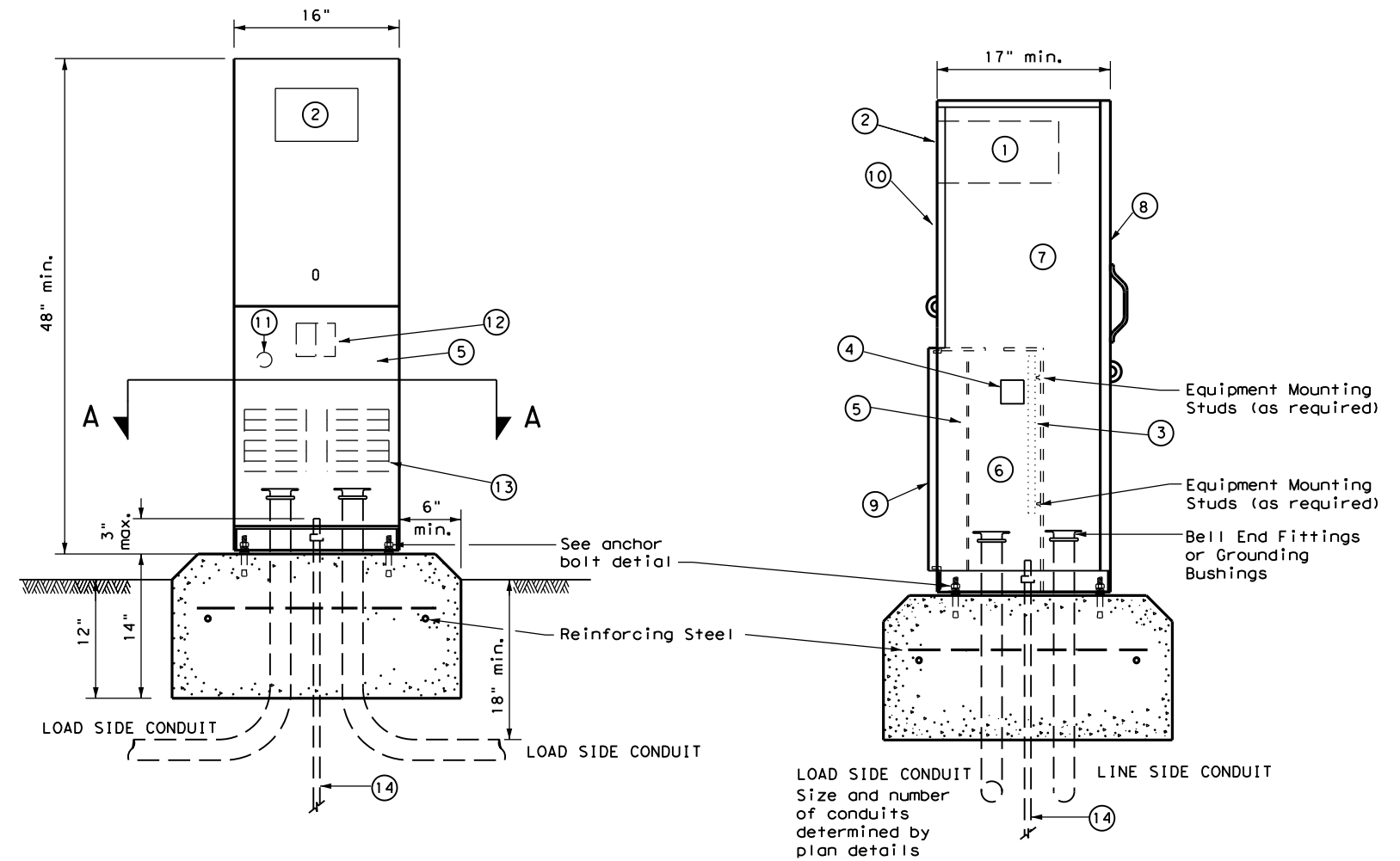

**FRONT VIEW**

**SIDE VIEW**

TYPE C shown, TYPE A similar except that TYPE A shall have individual circuit breakers (CB) mounted on an equipment mounting panel. CB Handles shall protrude through hinged deadfront trim.

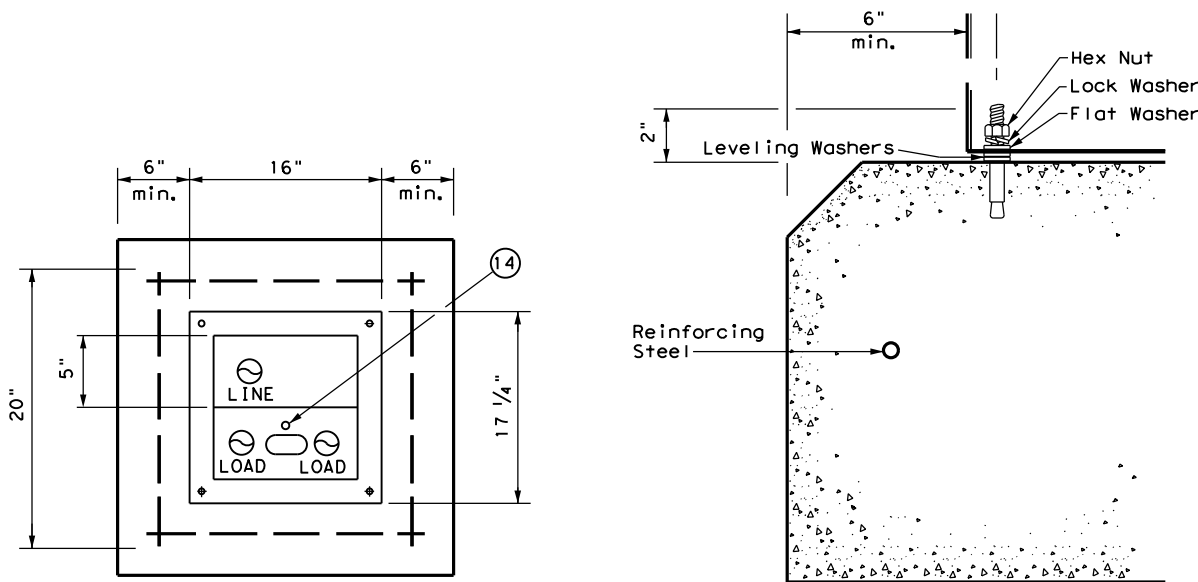

**SECTION A-A**

**ANCHOR BOLT DETAIL**

**LEGEND**

1	Meter Socket, (when required)
2	Meter Socket Window, (when required)
3	Equipment Mounting Panel
4	Photo Electric Control Window, (When required)
5	Hinged Deadfront Trim
6	Load Side Conduit Trim
7	Line Side Conduit Area
8	Utility Access Door, with handle
9	Pedestal Door
10	Hinged Meter Access
11	Control Station (H-O-A Switch)
12	Main Disconnect
13	Branch Circuit Breakers
14	Copper Clad Ground Rod - 5/8" X 10'

		Traffic Operations Division Standard	
<b>ELECTRICAL DETAILS          ELECTRICAL SERVICE SUPPORT          PEDESTAL SERVICE TYPE PS</b>			
<b>ED(9) - 14</b>			
FILE: ed9-14.dgn	DN: TxDOT	CK: TxDOT	DW: TxDOT
© TxDOT October 2014	CONT	SECT	JOB
REVISIONS	0918	00	392
DIST	COUNTY	SHEET NO.	
DAL	DALLAS, ETC.	84	

DISCLAIMER: The use of this standard is governed by the "Texas Engineering Practice Act". No warranty of any kind is made by TxDOT for any purpose whatsoever. TxDOT assumes no responsibility for the conversion of this standard to other formats or for incorrect results or damages resulting from its use.

DATE: 2/14/2024 3:29:29 PM  
 U:\TRAFFIC PROJECTS\0918-00-392 Non-Site 9-24\Microstation Files\085 ED(10)-14.dgn

**TIMBER POLE (TP) SERVICE SUPPORT NOTES**

1. Ensure electrical service support is a class 5 treated timber pole as per Item 627 "Treated Timber Poles." Embed timber pole to depth required in Item 627.
2. Conduit and electrical conductors attached to the electrical service pole and underground within 12 in. of service pole are not paid for directly but are subsidiary to the electrical service.
3. Install pole-top mounted photocell (T) on north side of pole, or in service enclosure (E) as required. See Electrical Service Data chart in plan set.
4. Gain pole as required to provide flat surface for each channel. Gain timber pole to 3/8 in. max. depth and 1 7/8 in. max. height. Gain pole in a neat and workmanlike manner.
5. Mount meter and service equipment on stainless steel or galvanized channel (Unistrut, Kindorf, or equal). Provide channel sized 1 in. to 3 3/4 in. maximum depth, and 1 1/2 in. to 1 5/8 in. maximum width. File smooth the cut ends of galvanized channel and paint with zinc rich paint before installing on pole. Secure each channel section to timber pole with two galvanized or SS lag bolts, 1/4 in. minimum diameter by 1 1/2 in. minimum length. Use a galvanized or SS flat washer on each lag bolt. Do not stack channel.
6. When excess length must be trimmed from poles, trim from the top end only.

- 1 Class 5 pole, height as required
- 2 Service drop from utility company (attached below weatherhead)
- 3 Service conduit (RMC) and service entrance conductors - One Red, One Black, One White (See Electrical Service Data)
- 4 Safety switch (when required)
- 5 Meter (when required)
- 6 Service enclosure
- 7 6 AWG bare grounding electrode conductor in 1/2 in. PVC to ground rod - extend 1/2 in. PVC 6 in. underground.
- 8 5/8 in. x 8 ft. Copper clad ground rod - drive ground rod to a depth of 2 in. to 4 in. below grade.
- 9 RMC same size as branch circuit conduit.
- 10 See pole-top mounted photocell detail on ED(5).
- 11 When required by the serving utility provide bare 6 AWG copper conductor. Run wire from pole top to butt wrap or copper butt plate. Protect conductor with non-conductive material to a height of 8 ft. above finished grade.
- 12 When required by utility, cut top of pole at an angle to enhance rain run off.

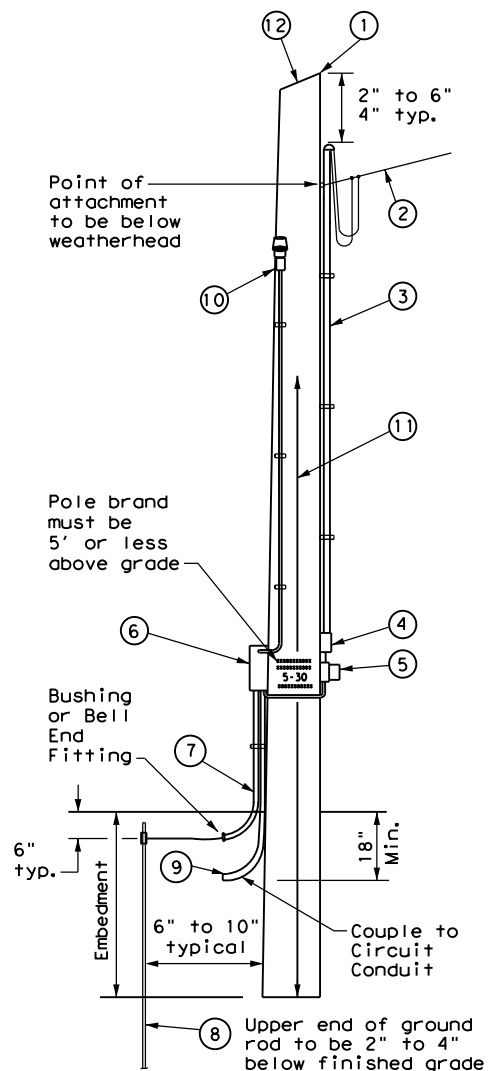

**SERVICE SUPPORT TYPE TP (O)**

**GRANITE CONCRETE (GC) & OTHER CONCRETE (OC) NOTES**

Ensure electrical service support structures bid as type Granite Concrete (GC) or Other Concrete (OC) meet the following requirements.

1. Provide GC and OC poles that meet the requirements of DMS 11080 "Electrical Services."
2. Provide prestressed concrete poles suitable for direct embedment into the ground without special foundations.
3. Verify poles are marked as required on DMS 11080. Location of marking should be approximately 4' above final grade. Use the two-point pickup locations when handling pole in horizontal position, and one-point pickup location for use in raising the pole to a vertical position. These marks are small but conspicuous.
4. Embed poles 42 in. or 10% of the length plus 2 ft., whichever is greater.
5. Ensure all installation details of services are in accordance with utility company specifications.
6. Install a one point rack or eye bolt bracket 6 inches to 12 inches below the weatherhead as an overhead service drop anchoring point for the electric utility.
7. Furnish and install galvanized or stainless steel channel strut 1 1/2 in. or 1 5/8 in. wide by 1 in. up to 3 3/4 in. deep (Unistrut, Kindorf, B-line or equal). Attach channel strut with stainless steel concrete anchors (max. 1" depth), square U-bolts or back to back channel strut with long bolts, or other secure mounting as approved by the Engineer. Ensure bolts are galvanized in accordance with ASTM A153. Do not stack channel struts.
8. Backfill the holes thoroughly by tamping in 6 in. lifts. After tamping to grade, place additional backfill material in a 6 inch high cone around the pole to allow for settling. Use material equal in composition and density to the surrounding area. Backfilling will not be paid for directly but is subsidiary to various bid items.

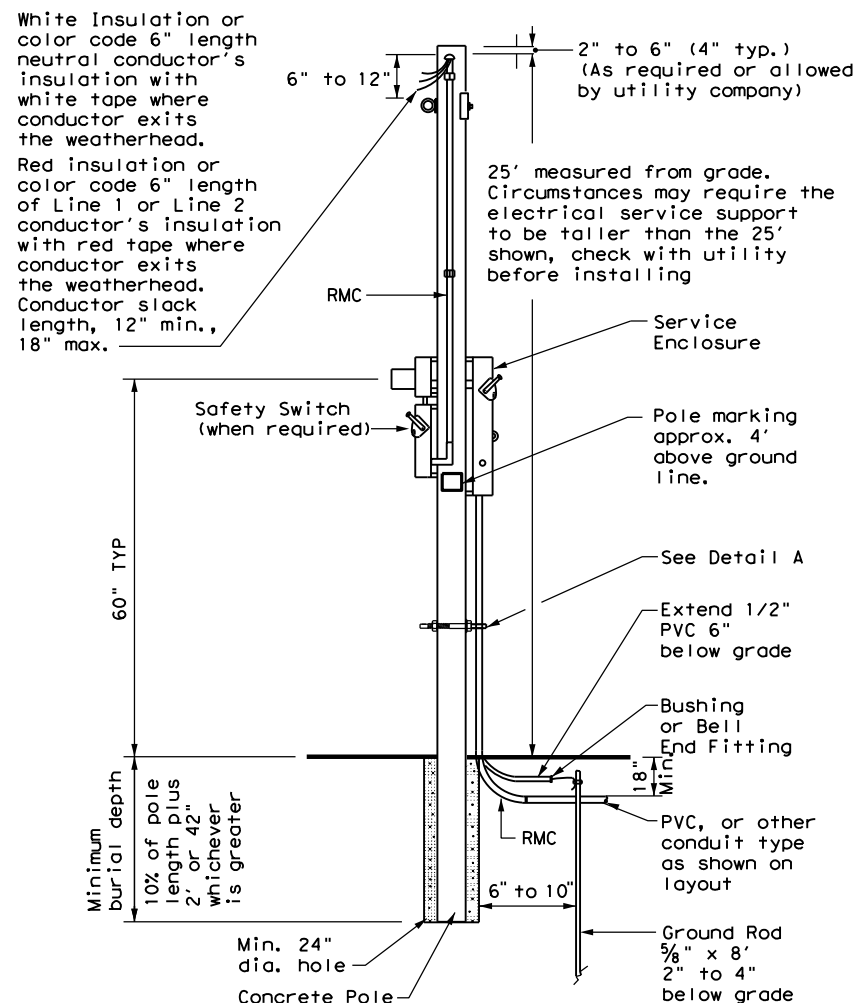

**CONCRETE SERVICE SUPPORT Overhead (O)**

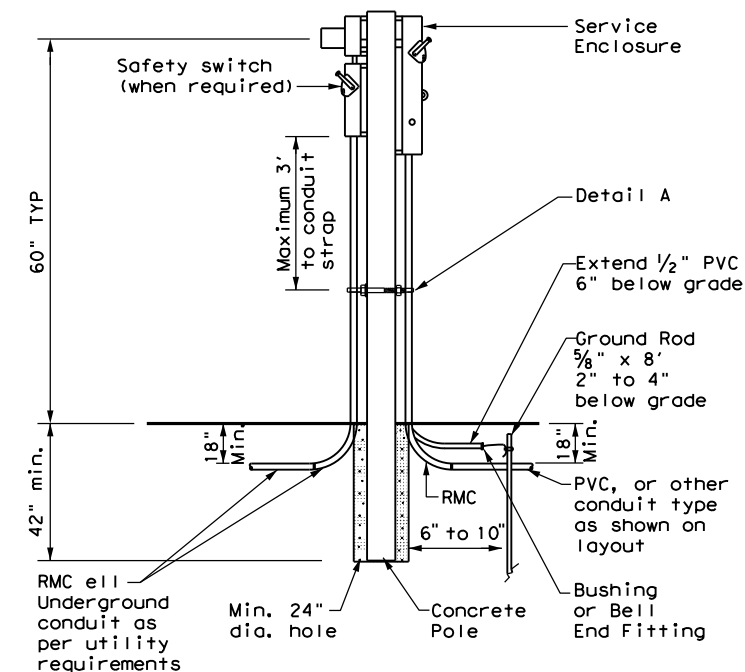

**CONCRETE SERVICE SUPPORT Underground (U)**

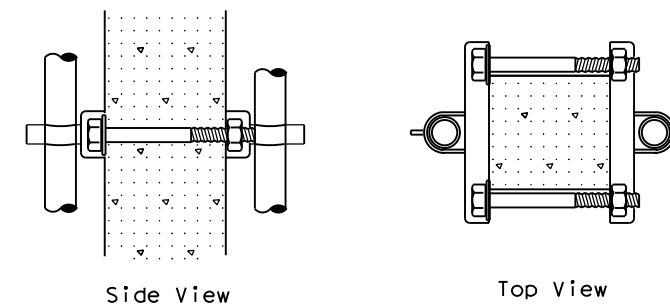

**DETAIL A**

See Note 7. Before installing channel that has been cut, file sharp edges and paint with zinc-rich paint. Ensure there is no paint splatter on the pole.

		<b>Traffic Operations Division Standard</b>	
<b>ELECTRICAL DETAILS SERVICE SUPPORT TYPES GC, OC, &amp; TP</b>			
<b>ED(10)-14</b>			
FILE: ed10-14.dgn	DN: TxDOT	CK: TxDOT	DW: TxDOT
© TxDOT October 2014	CONT	SECT	JOB
REVISIONS	0918 00	392	VA
DIST	COUNTY	SHEET NO.	
DAL	DALLAS, ETC.	85	

DISCLAIMER: The use of this standard is governed by the "Texas Engineering Practice Act". No warranty of any kind is made by TxDOT for any purpose whatsoever. TxDOT assumes no responsibility for the conversion of this standard to other formats or for incorrect results or damages resulting from its use.

DATE: 2/14/2024 3:30:17 PM  
 U:\TRAFFIC PROJECTS\0918-00-392 Non-Site 9-24\Microstation Files\086 ED(11)-14.dgn

**DUCT CABLE & HDPE CONDUIT NOTES**

1. Provide duct cable in accordance with Departmental Material Specification (DMS) 11060 "Duct Cable" and Item 622 "Duct Cable." Provide duct cable as listed on the Material Producer List (MPL) on the Department web site under "Roadway Illumination and Electrical Supplies" Item 622.
2. Provide High-Density Polyethylene (HDPE) conduit in accordance with DMS 11060 and Item 618, "Conduit." Provide HDPE as listed on the MPL on the Department web site under "Roadway Illumination and Electrical Supplies," Item 618.
3. Supply duct cable with a minimum 2 in. diameter, unless otherwise shown in the plans. Provide duct cable and HDPE conduit as shown by descriptive code or on the plans. Bend duct cable and HDPE conduit as recommended by the manufacturer, with a minimum bending radius of 26 in. for 2 in. duct. Follow manufacturers' recommendations when handling duct cable and HDPE conduit reels and during installation of duct cable and HDPE conduit.
4. Do not splice conductors within duct cable or HDPE conduit. Couple duct cable and HDPE entering a ground box or foundation to a PVC elbow. When galvanized steel RMC elbows are called for in the plans and any portion of the RMC elbow is buried less than 18" from possible contact, ground the RMC elbow.
5. Furnish and install duct cable with factory installed conductors, sized as shown in the plans and as required by the National Electrical Code (NEC). The NEC contains specific requirements for duct cable in Article, "Nonmetallic Underground Conduit with Conductors: Type NUCC."
6. When conduit casing is called for in the plans, extend duct cable or HDPE conduit through the conduit casing in one continuous length without connection to the casing.
7. Seal the ends of duct cable or HDPE conduit with duct seal, expandable foam, or other approved method after completing the pull tests required by Item 622.
8. Provide minimum cover of 24 in. under roadways, 18 in. in other locations, or as shown on the plans.
9. Furnish and install listed fittings to couple duct cable or HDPE conduit to other types of conduit. Duct cable and HDPE conduit may be field-threaded and spliced with PVC or RMC threaded couplings; connected with listed tie-wrap fittings; connected using listed coupling made of HDPE with stainless steel external banding clamps and locking rings; connected with approved electrofusion conduit couplings; or connected using an approved chemical fusion method using an epoxy or adhesive specifically designed for HDPE couplings and connectors all installed in accordance with their manufacturer's instructions. Do not use PVC glue on HDPE. Do not use water pipe fittings, or connect conduit with heat shrink tubing.

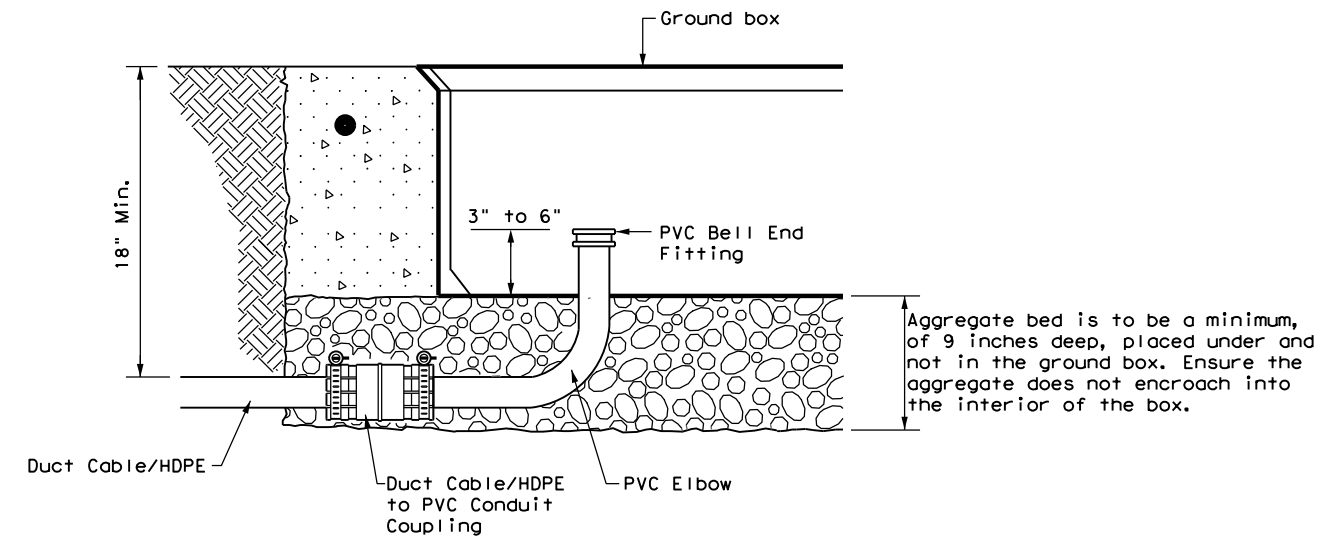

**DUCT CABLE/HDPE AT GROUND BOX**

When the upper end of an RMC EII does not enter the ground box, it may be extended with a SCH-40 PVC conduit nipple and bell end, provided there is a minimum of 18" of cover over all parts of the elbow. If not, a rigid extension and ground bushing is required.

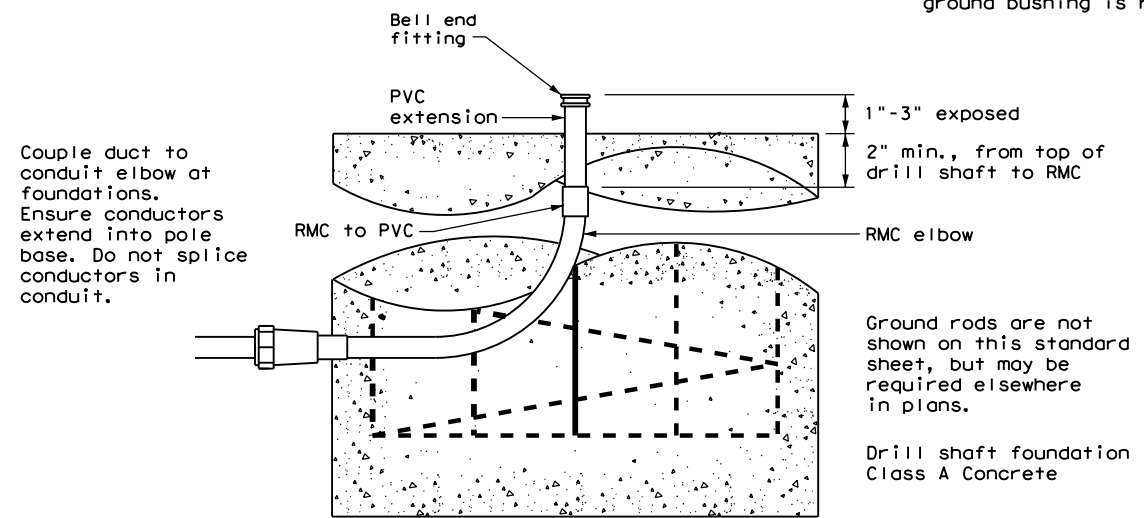

**DUCT CABLE / HDPE AT FOUNDATION**

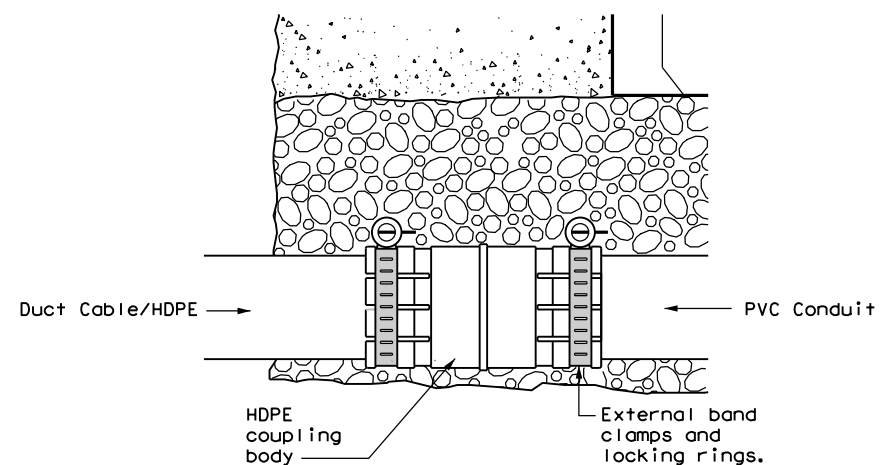

**DUCT CABLE/HDPE TO PVC**

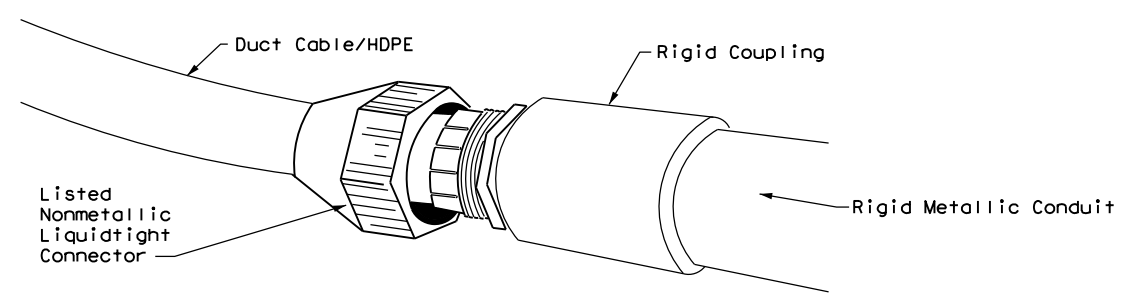

**DUCT CABLE/HDPE TO RMC**

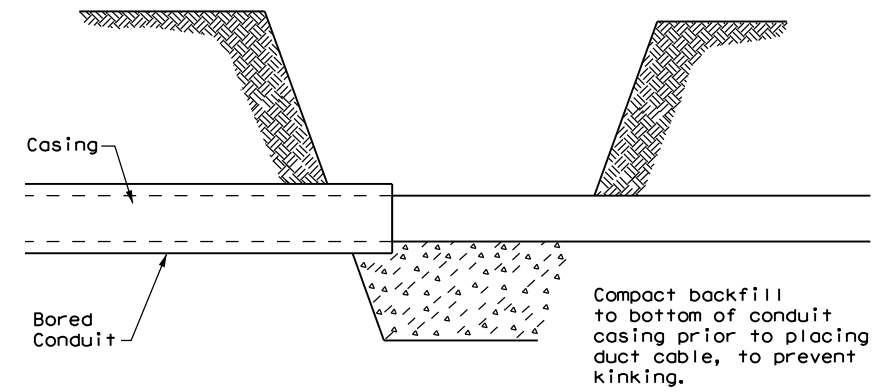

**BORE PIT DETAIL**

		Traffic Operations Division Standard	
<b>ELECTRICAL DETAILS          DUCT CABLE/          HDPE CONDUIT</b>			
<b>ED(11)-14</b>			
FILE: ed11-14.dgn	DN: TxDOT	CK: TxDOT	DW: TxDOT
© TxDOT October 2014	CONT	SECT	JOB
REVISIONS	0918	00	392
	DIST	COUNTY	SHEET NO.
	DAL	DALLAS, ETC.	86

DISCLAIMER: The use of this standard is governed by the "Texas Engineering Practice Act". No warranty of any kind is made by TxDOT for any purpose whatsoever. TxDOT assumes no responsibility for the conversion of this standard to other formats or for incorrect results or damages resulting from its use.

DATE: 2/14/2024 3:31:26 PM  
 U:\TRAFFIC PROJECTS\0918-00-392 Non-Site 9-24\Microstation Files\087 ED(12)-14.dgn

**BATTERY BOX GROUND BOXES NOTES**

**A. MATERIALS**

1. Provide polymer concrete or fiberglass reinforced plastic (FRP) battery box ground box and cover in accordance with Departmental Material Specification (DMS) 11071 "Battery Box Ground Boxes." Battery box will accommodate up to 4 batteries, each measuring 8 in. x 13.5 in. x 10 in. (W x L x D). Label battery box ground box cover in accordance with DMS 11071.
2. Supply a marine grade batteries with covers. Secure the marine grade batteries with covers to the stainless steel rack in the bottom of the ground box with tie down straps.

**B. CONSTRUCTION METHODS**

1. Ensure conduit entry will not interfere with placement of the batteries in the battery box ground box.
2. Remove all gravel and dirt from conduit. Cap all conduits prior to placing aggregate and setting battery box ground box. Provide Grade 3 or 4 coarse aggregate as shown on Table 2 of Item 302 "Aggregates for Surface Treatments." Ensure the aggregate bed is in place and is a minimum of 9 in. deep prior to setting the box. Install battery box ground box on top of aggregate.
3. Cast battery box aprons in place. Reinforcing steel may be field bent. Ensure the depth of concrete for the apron extends from finished grade to the top of the aggregate bed under the box. Battery box ground box aprons, including concrete and reinforcing steel, are subsidiary to battery box ground boxes when called for by descriptive code.
4. Bolt covers down when not working in battery box ground boxes. Keep bolt holes in the box clear of dirt.

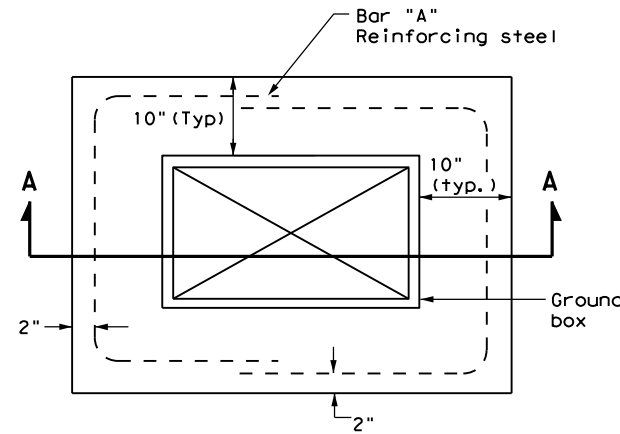

**PLAN VIEW**

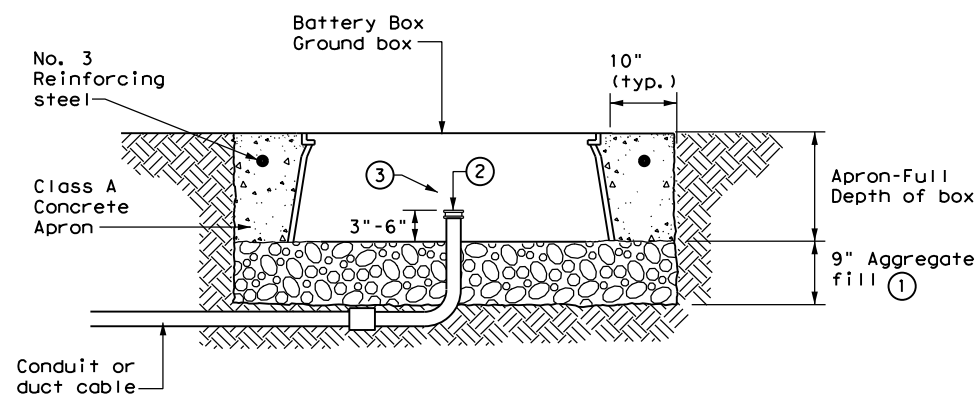

**SECTION A - A**

**APRON FOR BATTERY BOX GROUND BOXES**

- ① Place aggregate under the box and not in the box. Aggregate should not encroach on the interior volume of the box.
- ② Install bushing or bell end fitting on the upper end of all ellis.
- ③ Install all conduits in a neat and workmanlike manner.

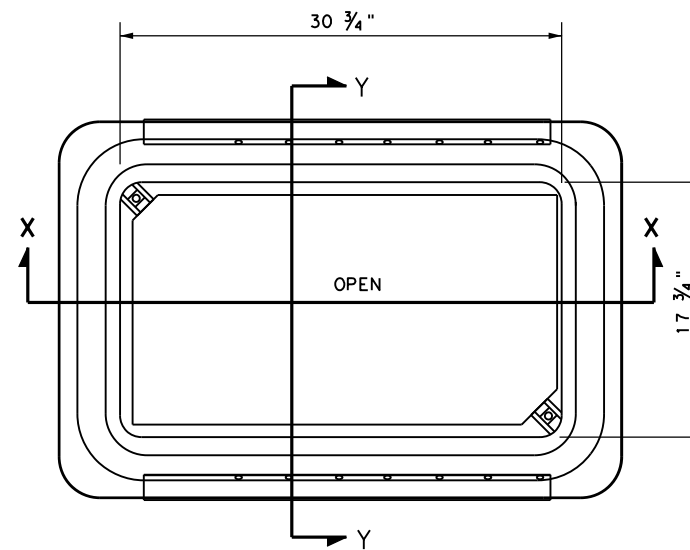

**BATTERY BOX TOP VIEW**

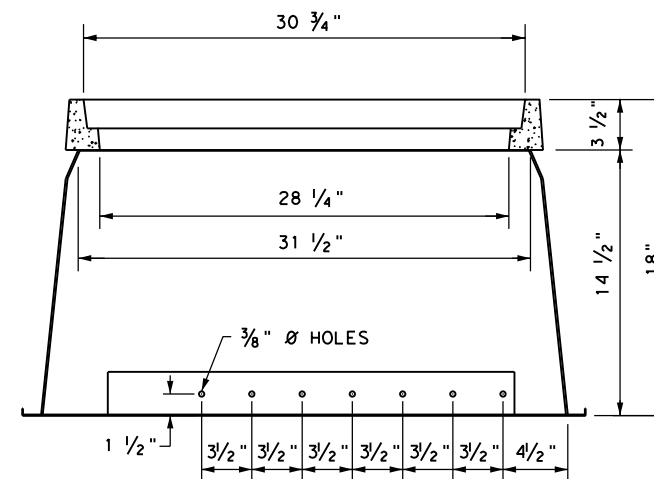

**SECTION X-X**

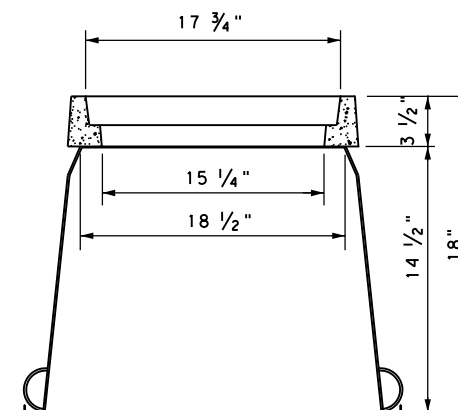

**SECTION Y-Y**

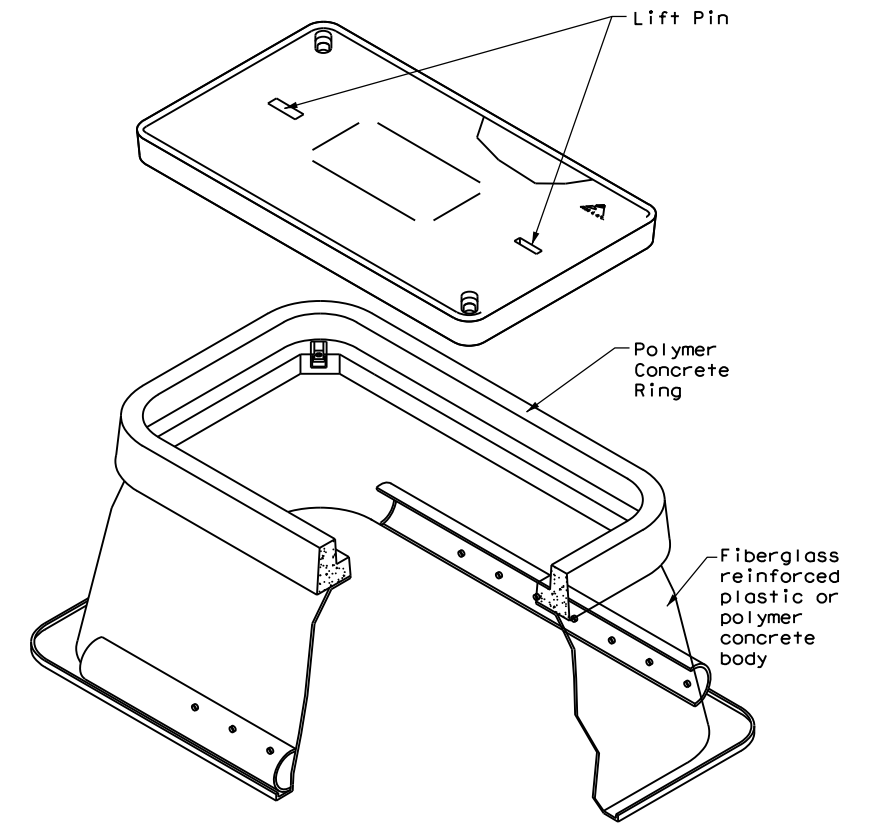

				Traffic Operations Division Standard	
<b>ELECTRICAL DETAILS          BATTERY BOX          GROUND BOXES</b>					
<b>ED(12)-14</b>					
FILE:	ed12-14.dgn	DN:	TxDOT	CK:	TxDOT
© TxDOT	October 2014	CONT	SECT	JOB	HIGHWAY
REVISIONS		0918	00	392	VA
DIST	COUNTY	SHEET NO.			
DAL	DALLAS, ETC.	87			

DISCLAIMER: The use of this standard is governed by the "Texas Engineering Practice Act". No warranty of any kind is made by TxDOT for any purpose whatsoever. TxDOT assumes no responsibility for the conversion of this standard to other formats or for incorrect results or damages resulting from its use.

DATE: 2/14/2024 3:33:04 PM  
 U:\TRAFFIC PROJECTS\0918-00-392 Non-Site 9-24\Microstation Files\088-089 LD(1)-03.dgn

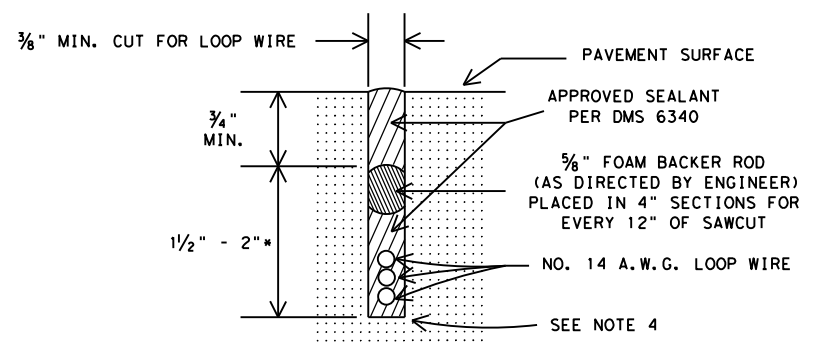

**LOOP SAW CUT CROSS-SECTION**

\* SAWCUTS IN BRIDGE DECKS ARE TYPICALLY 1" DEPTH MAXIMUM  
 SAWCUTS IN BRIDGE DECKS AND ACROSS EXPANSION JOINTS SHALL BE AS APPROVED BY ENGINEER

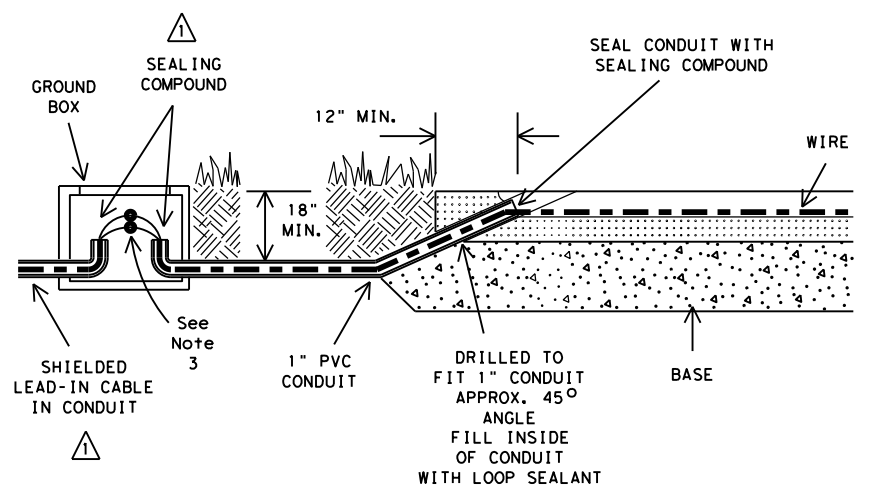

**TYPICAL LEAD IN CONFIGURATION (WITHOUT CURBING)**

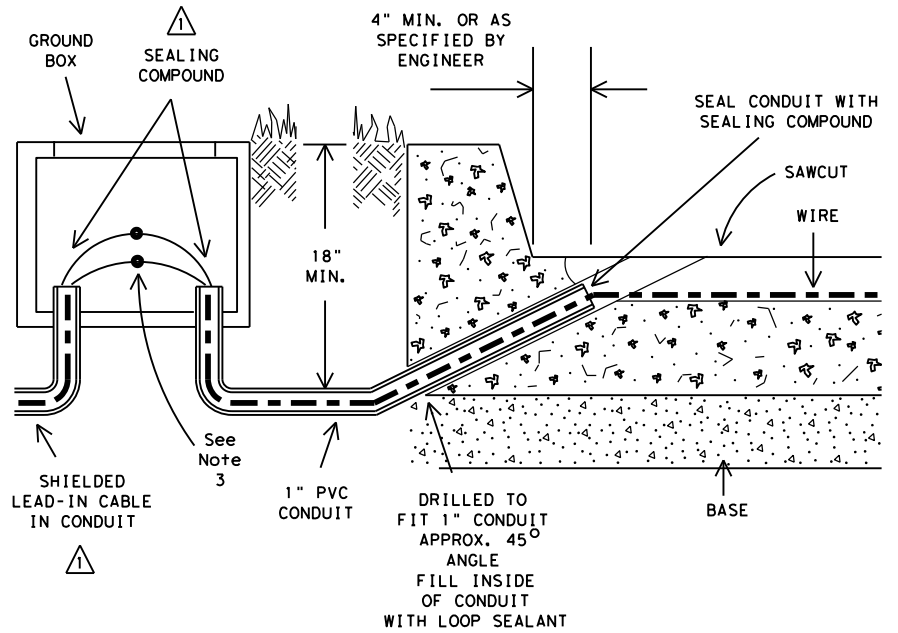

**TYPICAL LEAD IN CONFIGURATION (WITH CURBING)**

**TYPICAL LOOP DETECTOR LAYOUTS**

(AS SPECIFIED IN PLANS)

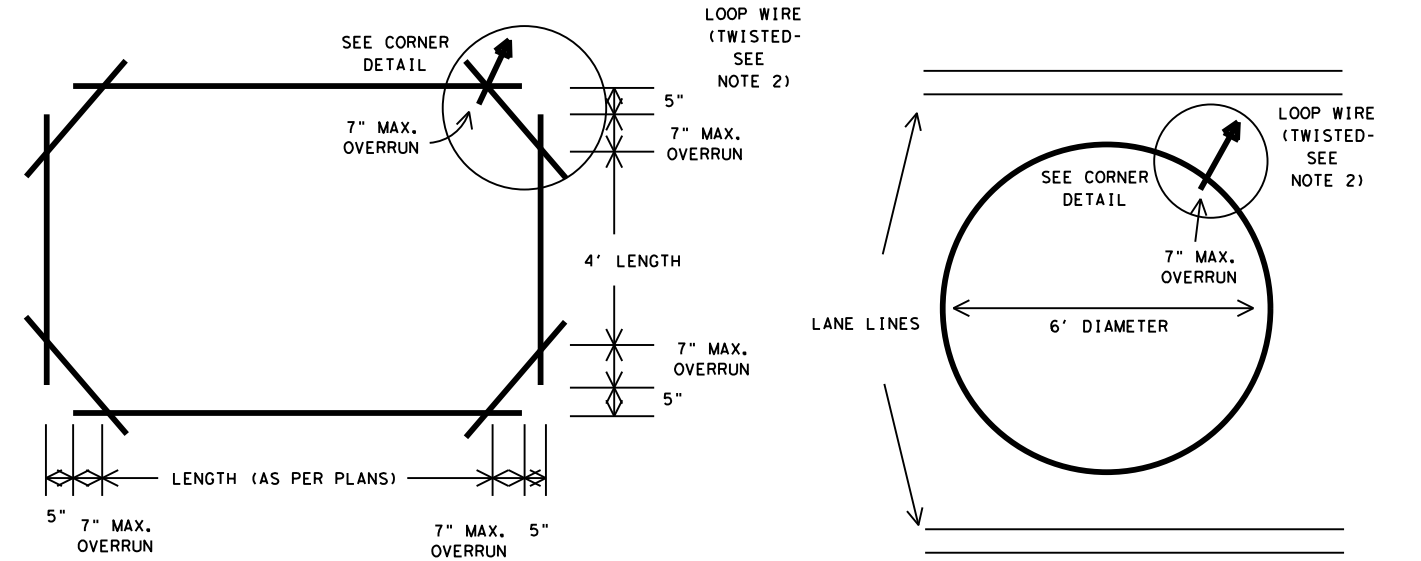

**RECTANGULAR**

**CIRCULAR**

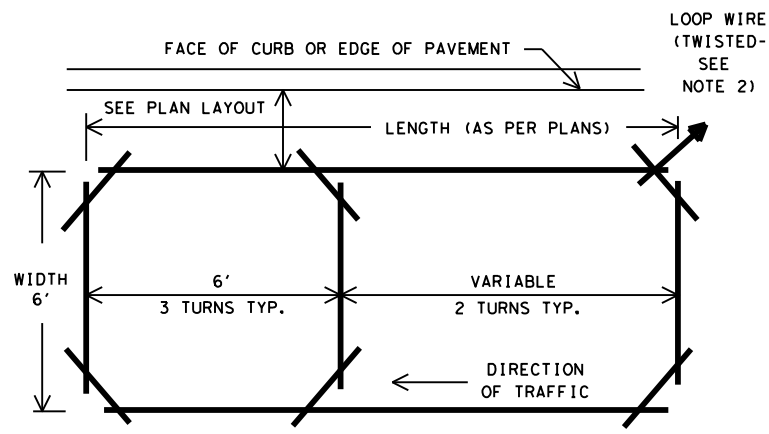

**POWER HEADER**

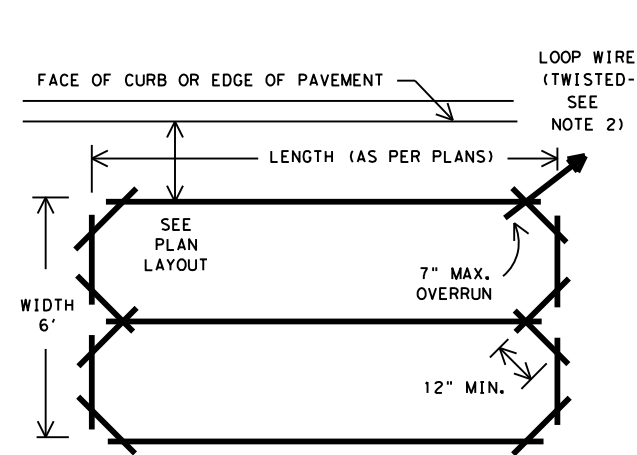

**QUADRAPOLE**

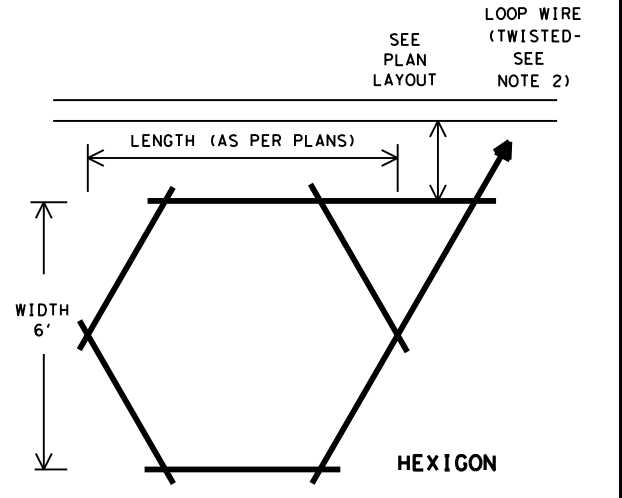

**HEXIGON**

**GENERAL NOTES:**

- The pavement cut is to be made with a concrete saw to neat lines and loose material removed. The cut shall be clean and dry when the wire and sealing compound is placed.
- Loop wire shall be 14 AWG Stranded Type XHHW. Wire from the loop to the ground box shall be twisted a minimum of 5 turns per foot. No splices shall be permitted in the loop or in the run to the ground box.
- The home run cable from the pull box to the controller shall be IMSA 50-2 shielded cable and shall be soldered to the loop wire. The solder joints shall be sealed with Scotchcast or other method acceptable to the Engineer. The shield shall be grounded only at the controller end. Loop home run cable shall be two conductor 14 AWG shielded, Type XHHW.
- All wire placed in the saw cut shall be sealed by fully encapsulating it in a sealant acceptable to the Engineer. Sealing compound shall be in accordance with DMS 6340.
- The loop location, configuration and number of turns shall be as indicated on the plans or as directed by the Engineer.

**Recommended Number of Turns for Loop Detectors**

LOOP PERIMETER SIZE (FT.)	NUMBER OF TURNS	APPROXIMATE LOOP SIZES INCLUDED
24' or Less	3 or 4	5' x 5', 6' x 6'
25' - 110'	2 or 3	6' x 10', 6' x 45'
110' or More	1 or 2	6' x 50' or Longer

- A separate saw cut shall be made from each loop to the edge of pavement or as specified by the Engineer.
- Splices between the loop lead-in cable and loop detector shall be made only in the ground box near the loop it is serving.
- Circular loops may use prewound loops encased in continuous pvc tubing. Sawcut width may be adjusted to accommodate tubing.
- The lead-in wire in the circular loop shall be coiled at the 3 inch drilled corner to reduce bending stress.
- Loop duct may be used as specified by Engineer.

For additional information refer to "Texas Traffic Signal Detector" manual, TTI Report 1163-1.

**TYPICAL CORNER DETAILS**

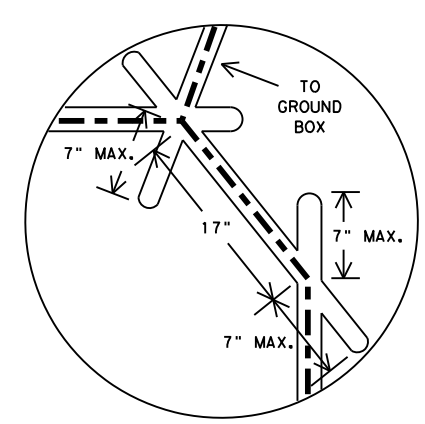

**RECTANGULAR & HEXIGON LOOP SAWCUT CORNER DETAIL**

7" OVERRUN BASED ON 24" DIAMETER SAW BLADE

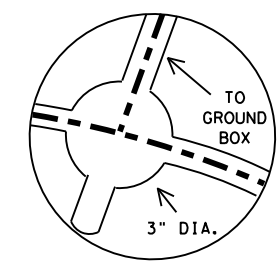

**CIRCULAR LOOP DRILLED CORNER DETAIL**

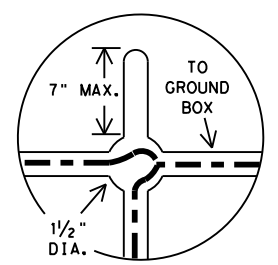

**RECTANGULAR & HEXIGON LOOP (ALT.) DRILLED CORNER DETAIL**



**LOOP DETECTOR INSTALLATION DETAILS**

**LD(1)-03**

© TxDOT December 1998	DN: TxDOT	CK: TxDOT	DW: TxDOT	CK: TxDOT
2-99 REVISIONS	CONT	SECT	JOB	HIGHWAY
1-03	091800		392	VA
	DIST	COUNTY		SHEET NO.
	DAL	DALLAS, ETC.		88



DISCLAIMER: The use of this standard is governed by the "Texas Engineering Practice Act". No warranty of any kind is made by TxDOT for any purpose whatsoever. TxDOT assumes no responsibility for the conversion of this standard to other formats or for incorrect results or damages resulting from its use.

DATE: 2/14/2024 3:33:33 PM  
 U:\TRAFFIC PROJECTS\0918-00-392 Non-Site 9-24\Microstation Files\088-089 LD(1-2)-03.dgn

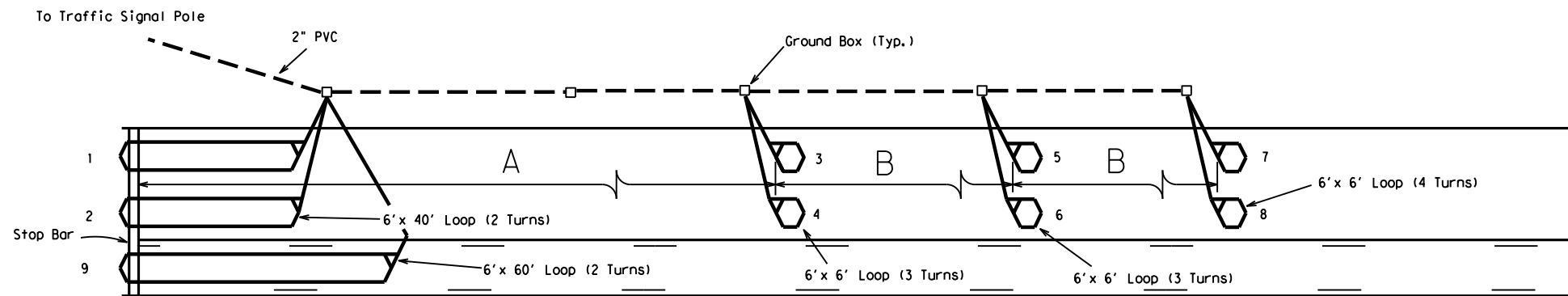

55 MPH ( A=225', B=95' ) 60 MPH ( A=275', B=100' )  
 65 MPH ( A=320', B=110' ) 70 MPH ( A=350', B=125' )

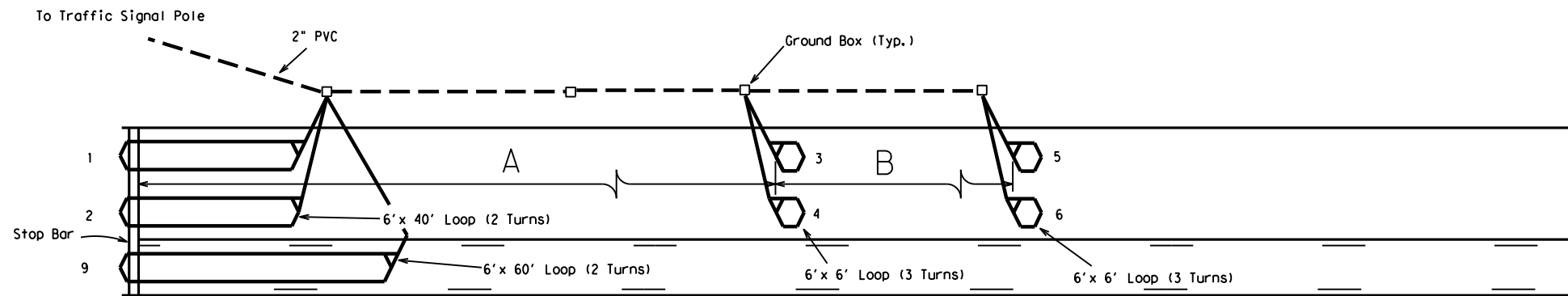

35 MPH ( A=90', B=100' ) 40 MPH ( A=110', B=130' )  
 45 MPH ( A=175', B=115' ) 50 MPH ( A=220', B=130' )

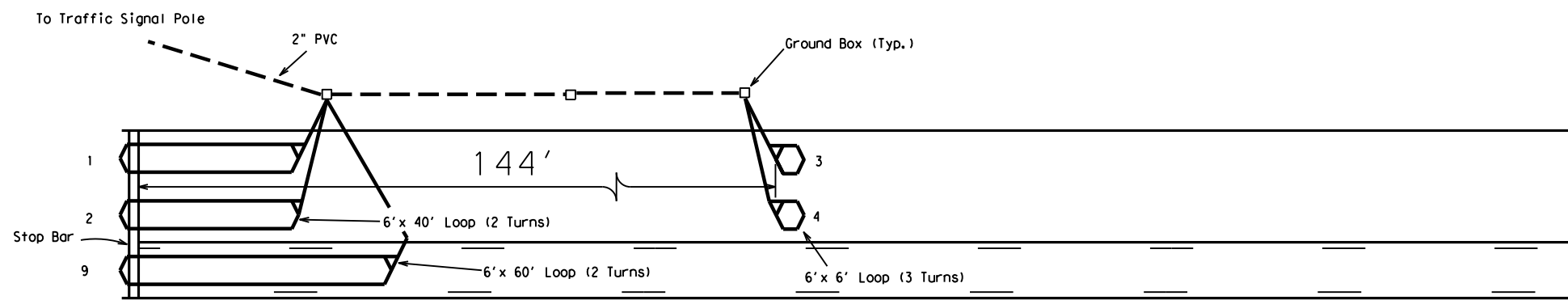

30 MPH

GENERAL NOTES:

- Loops 1 and 2 shall be connected to the controller cabinet by means of the same loop lead-in (2/C #14 AWG).
- Loops 3 thru 6 shall be connected to the controller cabinet by means of the same loop lead-in (2/C #14 AWG).
- Loops 7 and 8 shall be connected to the controller cabinet by means of the same loop lead-in (2/C #14 AWG).
- Loop 9 shall be connected to the controller cabinet by means of a loop lead-in (2/C #14 AWG). Loop 9 shall be placed only when a left turn lane exists.

LOOP WINDING DETAILS

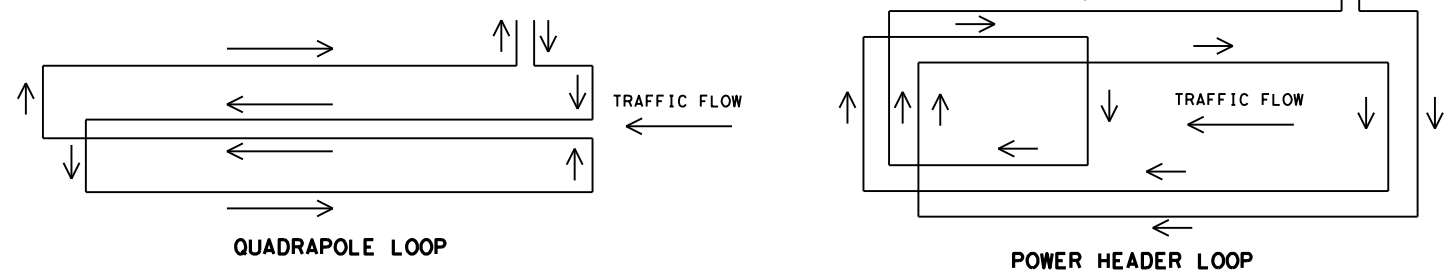

LOOP DETECTOR PLACEMENT DETAILS

LD(2)-03

© TxDOT January 2003		DN: TxDOT	CK: TxDOT	DW: TxDOT	CK: TxDOT
REVISIONS		CONT	SECT	JOB	HIGHWAY
		0918	00	392	VA
		DIST	COUNTY		SHEET NO.
		DAL	DALLAS, ETC.		89

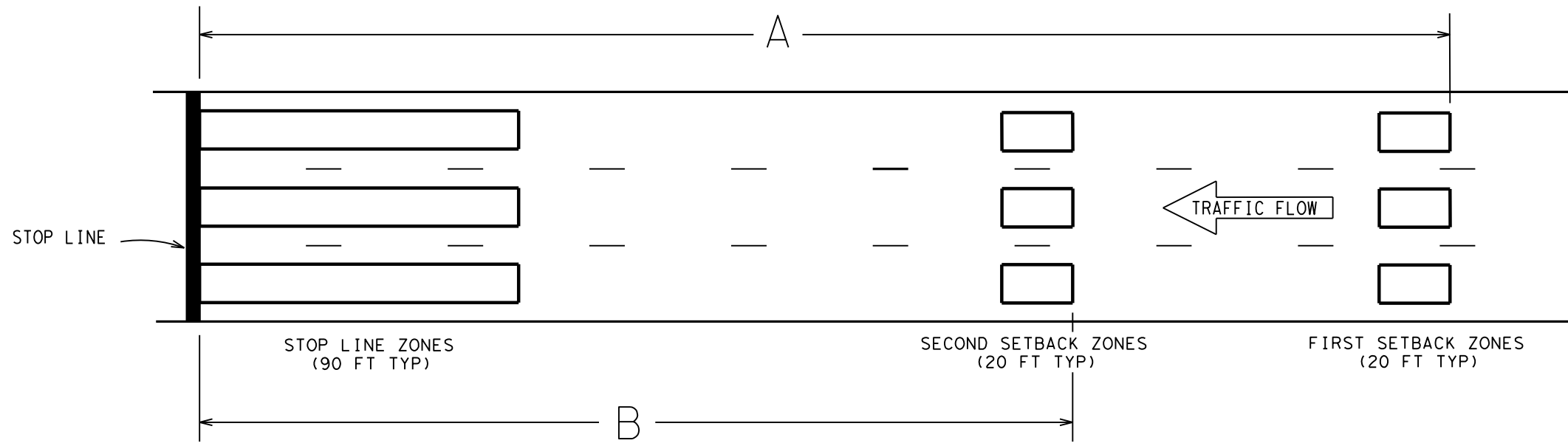

APPROACH SPEED LIMIT (MPH)	DISTANCE <sup>2</sup> BETWEEN CAMERA AND STOP LINE (FT)	DISTANCE <sup>1</sup> A (FT)	CAMERA HEIGHT (FT)									
			24	28	32	36	40	24	28	32	36	40
			DISTANCE B (FT)					EXTENSION ON 2ND DET. ZONE (SEC.)				
60	80	470	280	295	305	310	315	0.0	0.0	0.0	0.5	0.5
	150	470	270	285	295	300	310	0.0	0.0	0.0	0.0	0.5
55	80	430	255	265	275	280	285	0.0	0.0	0.0	0.5	0.5
	150	430	245	255	265	275	280	0.0	0.0	0.0	0.0	0.5
50	80	390	235	245	250	255	260	0.0	0.0	0.5	0.5	0.5
	150	390	220	230	240	245	250	0.0	0.0	0.0	0.0	0.5
45	80	350	210	215	220	225	230	0.0	0.0	0.5	0.5	0.5
	150	350	190	200	210	215	220	0.0	0.0	0.0	0.0	0.5

- Distances shown are based on a 20' detection zone and a 1.0 second passage time setting.
- Distance between the camera and the stop line, as measured parallel to the direction of travel.

DATE: 2/15/2024 8:18:37 AM  
 U:\TRAFFIC PROJECTS\0918-00-392 Non-Site 9-24\Microstation Files\090 VDZ-04 (DAL).dgn

**DALLAS DISTRICT STANDARD**



**VIDEO DETECTION  
 ZONE PLACEMENT  
 VDZ-04 (DAL)**

© TxDOT September 2004		DR- THW	CK- CDB	DR- BES	CK- TRF-Aus.
REVISIONS	FED. RD. DIV. NO.	PROJECT NO.			HIGHWAY NO.
	6	(SEE TITLE SHEET)			VA
	STATE	DISTRICT	COUNTY		SHEET NO.
	TEXAS	DAL	DALLAS, ETC.		90
	CONTROL	SECTION	JOB		
	0918	00	392		

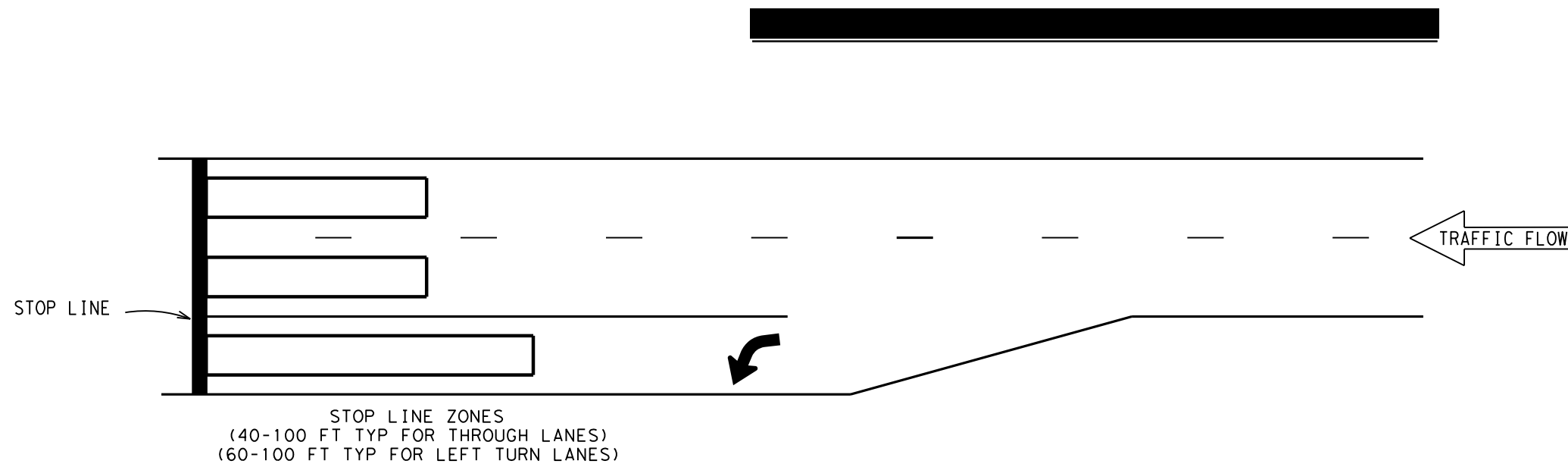

APPROACH SPEED LIMIT (MPH)	MINIMUM RANGE OF ADVANCE DETECTION (LF)
40	355
45	400
50	440
55	490
60	530
65	575
70	620

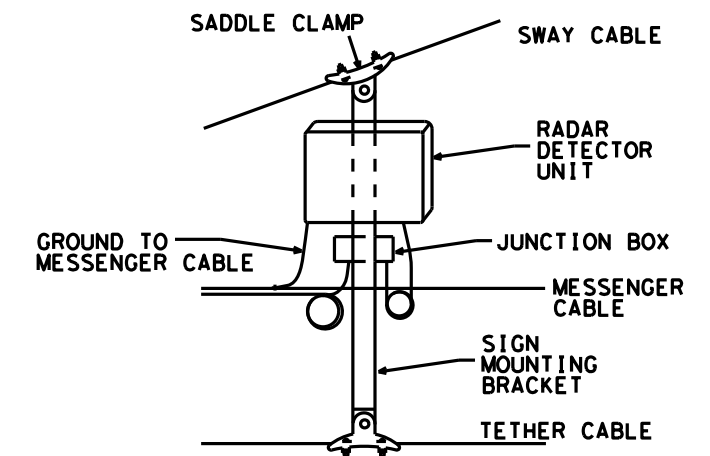
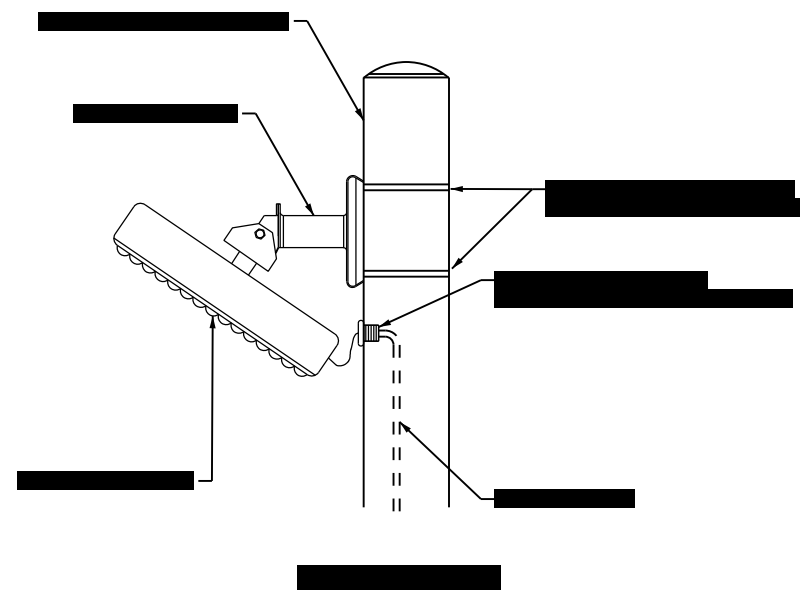
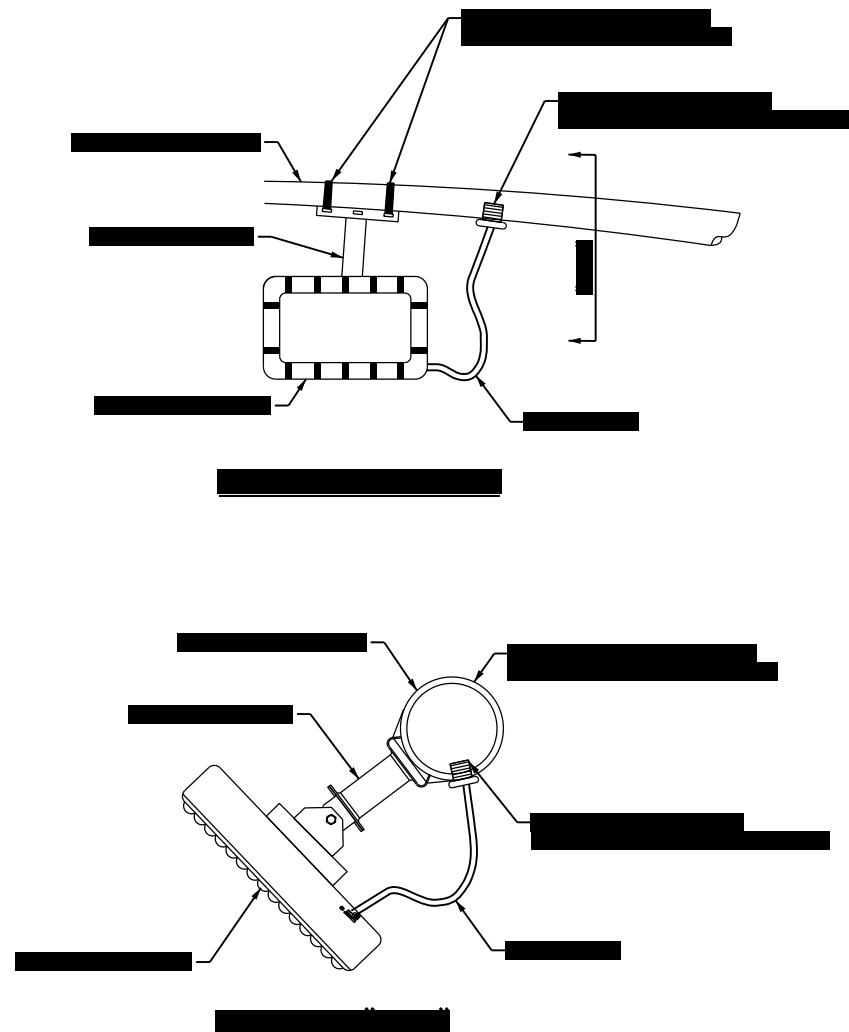

NOTES:

1. THE RADAR SENSOR MOUNTING BRACKET MUST BE ADJUSTABLE TO TILT UP, DOWN, LEFT, RIGHT, AND TO ROTATE.
2. THE RADAR DETECTOR UNITS SHOWN ARE NOT INTENDED TO REPRESENT ANY SPECIFIC BRAND OR PRODUCT, AND ALTERNATE MOUNTING METHODS MAY BE SUBMITTED FOR APPROVAL.

DALLAS DISTRICT STANDARD



RADAR VEHICLE DETECTION SYSTEM  
RVDS-23 (DAL)

REVISIONS	FED. RD. DIV. NO.	FEDERAL AID PROJECT NO.	HIGHWAY NO.
	6	(SEE TITLE SHEET)	VA
	STATE	DISTRICT COUNTY	SHEET NO.
	TEXAS	18 DALLAS, ETC.	91
	CONTROL	SECTION JOB	
	0918	00 392	

DISCLAIMER: The use of this standard is governed by the "Texas Engineering Practice Act". No warranty of any kind is made by TxDOT for any purpose whatsoever. TxDOT assumes no responsibility for the conversion of this standard to other formats or for incorrect results or damages resulting from its use.

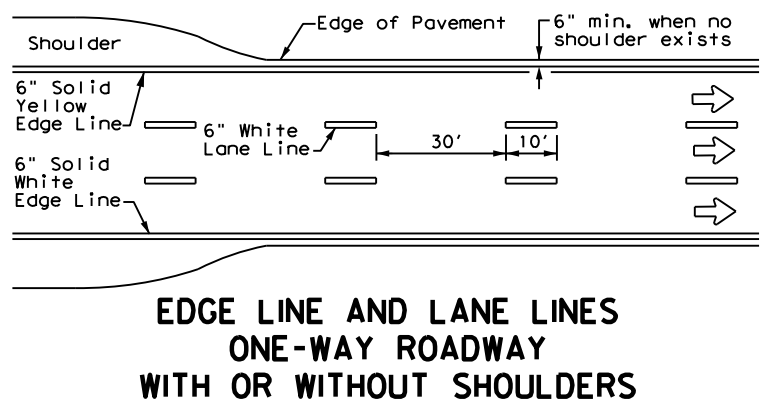

**EDGE LINE AND LANE LINES  
ONE-WAY ROADWAY  
WITH OR WITHOUT SHOULDERS**

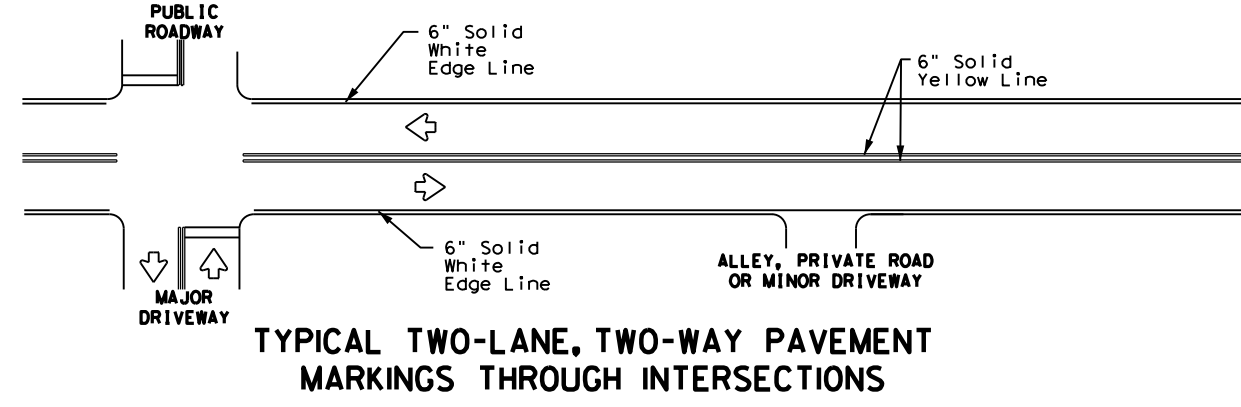

**TYPICAL TWO-LANE, TWO-WAY PAVEMENT  
MARKINGS THROUGH INTERSECTIONS**

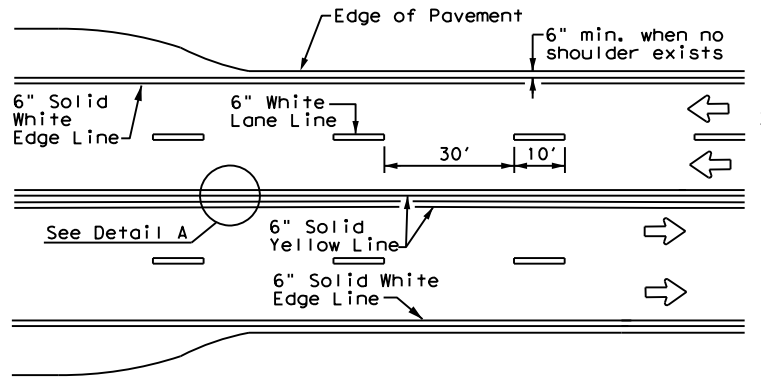

**CENTERLINE AND LANE LINES  
FOUR LANE TWO-WAY ROADWAY  
WITH OR WITHOUT SHOULDERS**

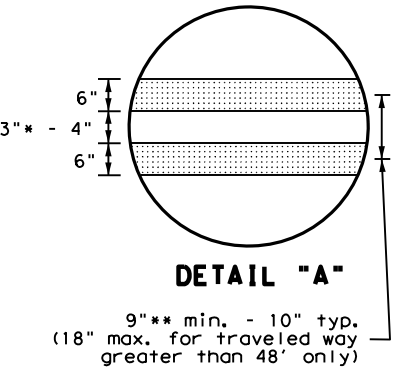

\* 2" minimum for restripe projects when approved by the Engineer.  
 \*\* 8" minimum for restripe projects when approved by the Engineer.

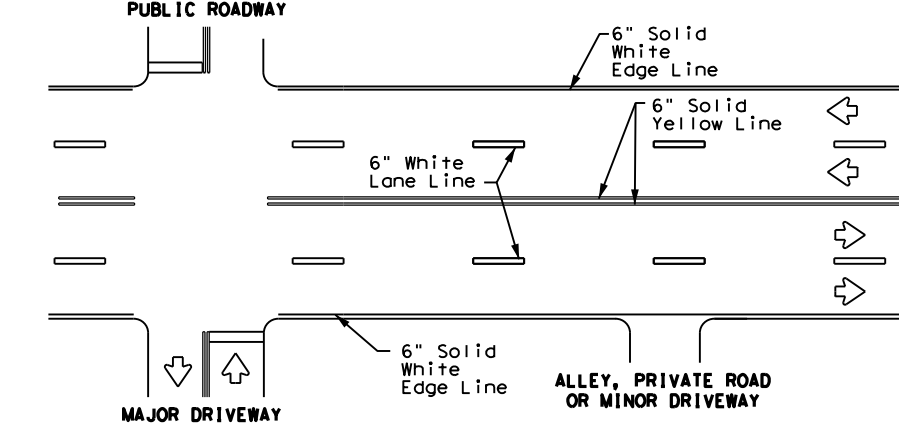

**TYPICAL MULTI-LANE, TWO-WAY PAVEMENT  
MARKINGS THROUGH INTERSECTIONS**

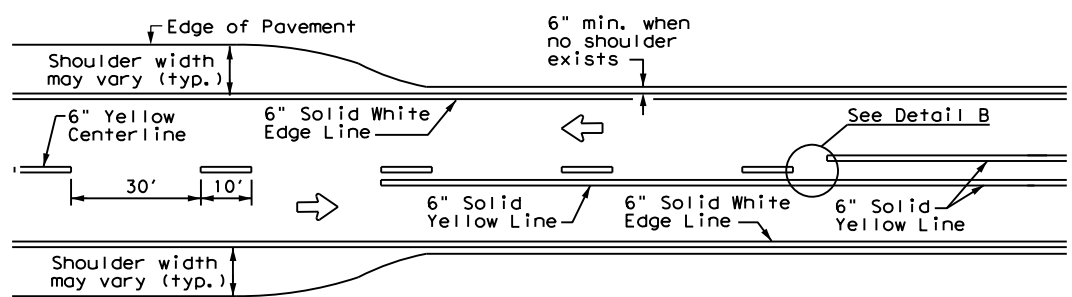

**TWO LANE TWO-WAY ROADWAY  
WITH OR WITHOUT SHOULDERS**

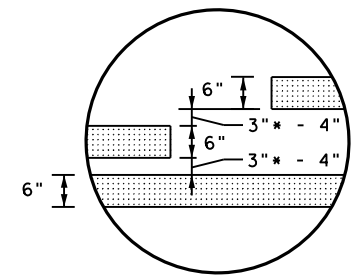

\* 2" minimum for restripe projects when approved by the Engineer.

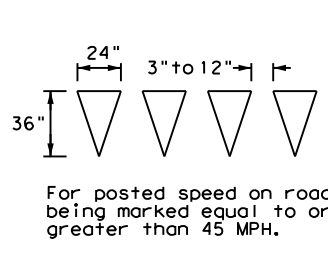

**YIELD LINES**

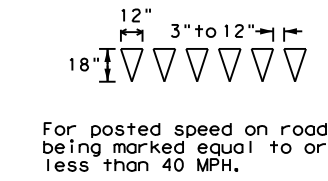

**NOTES**

- Where divided highways are separated by median widths at the median opening itself of 30 feet or more, median openings shall be signed as two separate intersections. Each median opening has two width measurements, with one measurement for each approach. The narrow median width will be the controlling width to determine if signs are required. Yield signs are the typical intersection control. Stop signs and stop bars are optional as determined by the Engineer.
- Install median striping (double yellow centerlines and stop lines/yield lines) when a 50' or greater median centerline can be placed. Stop lines shall only be used with stop signs. Yield lines shall only be used with yield signs.
- Length of turn bays, including taper, deceleration, and storage lengths shall be as shown on the plans or as directed by the Engineer.

**GENERAL NOTES**

- Edge line striping shall be as shown in the plans or as directed by the Engineer. The edge line should not be placed less than 6 inches from the edge of pavement. This distance may vary due to pavement raveling or other conditions. Edge lines are not required in curb and gutter sections of roadways.
- The traveled way includes only that portion of the roadway used for vehicular travel. It does not include the parking lanes, sidewalks, berms and shoulders. The traveled ways shall be measured from the center of edge line to the center of edge line of a two lane roadway.

MATERIAL SPECIFICATIONS	
PAVEMENT MARKERS (REFLECTORIZED)	DMS-4200
EPOXY AND ADHESIVES	DMS-6100
BITUMINOUS ADHESIVE FOR PAVEMENT MARKERS	DMS-6130
TRAFFIC PAINT	DMS-8200
HOT APPLIED THERMOPLASTIC	DMS-8220
PERMANENT PREFABRICATED PAVEMENT MARKINGS	DMS-8240

All pavement marking materials shall meet the required Departmental Material Specifications as specified by the plans.

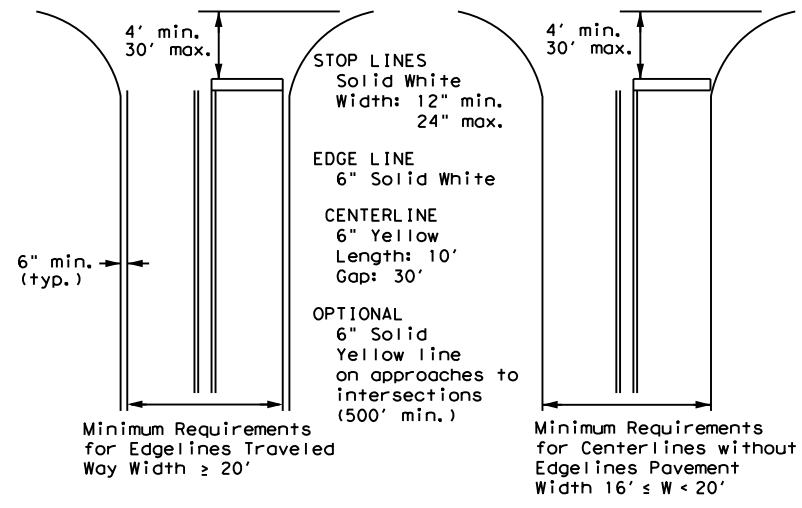

NOTE: Traveled way is exclusive of shoulder widths. Refer to General Note 2 for additional details.

**GUIDE FOR PLACEMENT OF STOP LINES,  
EDGE LINE & CENTERLINE**  
Based on Traveled Way and Pavement Widths for Undivided Roadways

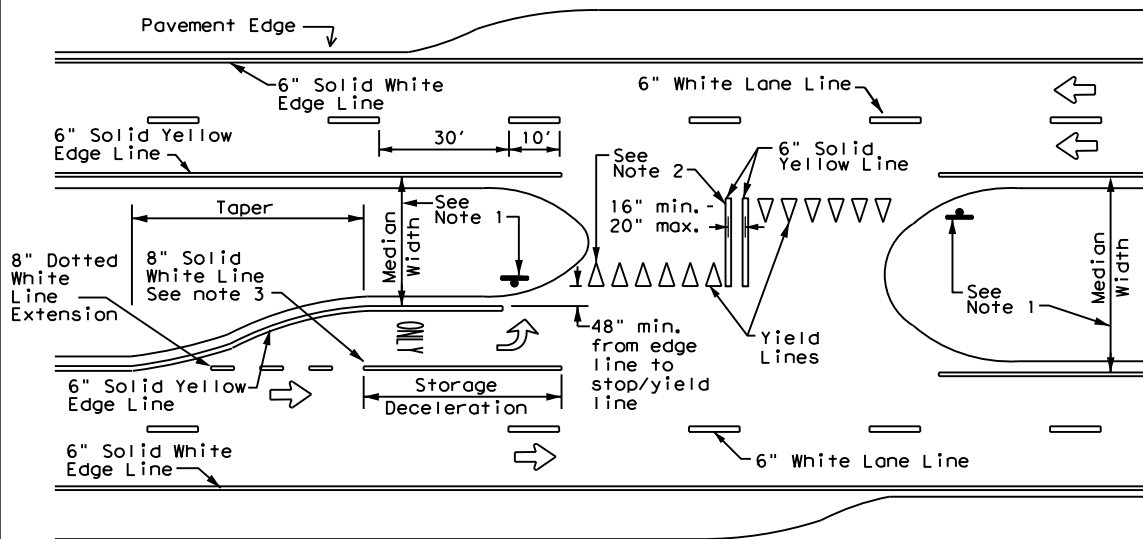

**FOUR LANE DIVIDED ROADWAY CROSSOVERS**

**TYPICAL STANDARD  
PAVEMENT MARKINGS**

**PM(1) - 22**

FILE: pm1-22.dgn	DN:	CK:	DW:	CK:
© TxDOT December 2022	CONT	SECT	JOB	HIGHWAY
REVISIONS	0918	00	392	VA
11-78 8-00 6-20	DIST	COUNTY	SHEET NO.	
8-95 3-03 12-22	DAL	DALLAS, ETC.	92	
5-00 2-12				

DATE:  
FILE:

# REFLECTIVE RAISED PAVEMENT MARKERS FOR VEHICLE POSITIONING GUIDANCE

DISCLAIMER: The use of this standard is governed by the "Texas Engineering Practice Act". No warranty of any kind is made by TxDOT for any purpose whatsoever. TxDOT assumes no responsibility for the conversion of this standard to other formats or for incorrect results or damages resulting from its use.

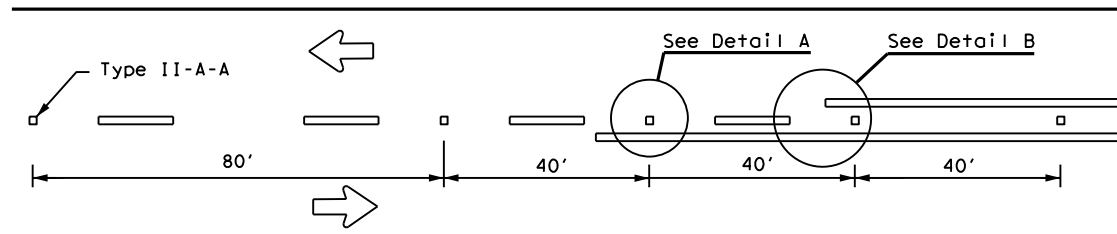

**CENTERLINE FOR ALL TWO LANE TWO-WAY ROADWAYS**

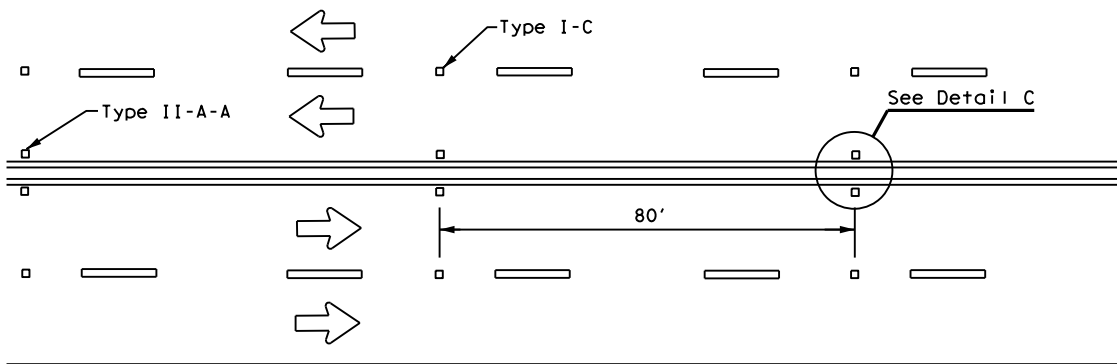

**CENTERLINE & LANE LINES  
FOR FOUR LANE TWO-WAY ROADWAYS**

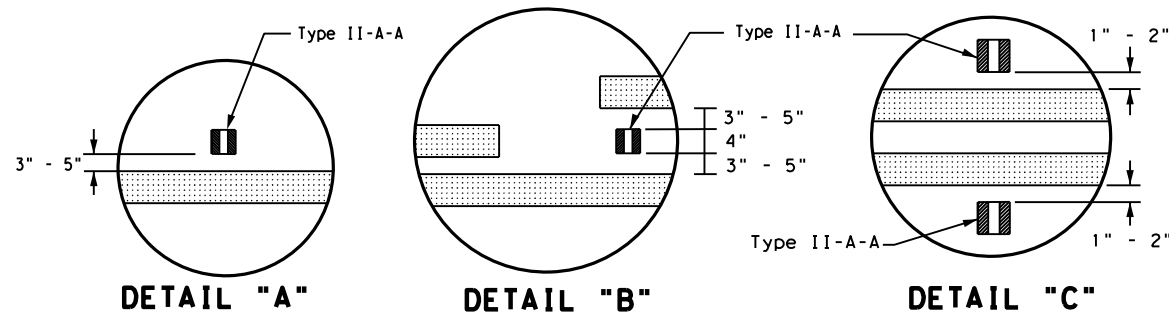

**DETAIL "A"**

**DETAIL "B"**

**DETAIL "C"**

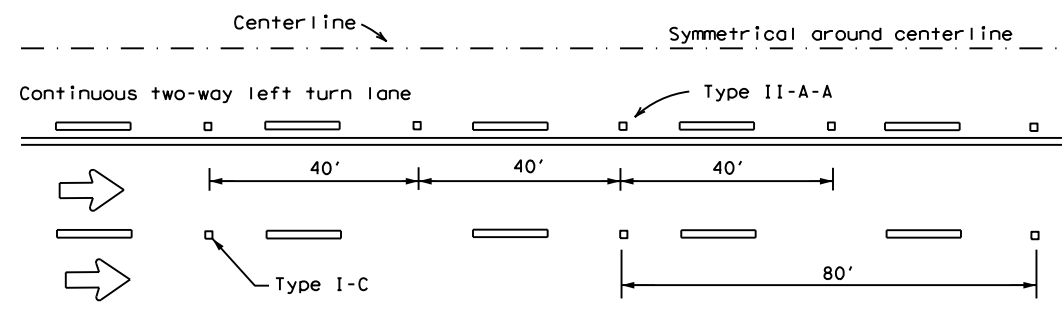

**CENTERLINE AND LANE LINES FOR TWO-WAY LEFT TURN LANE**

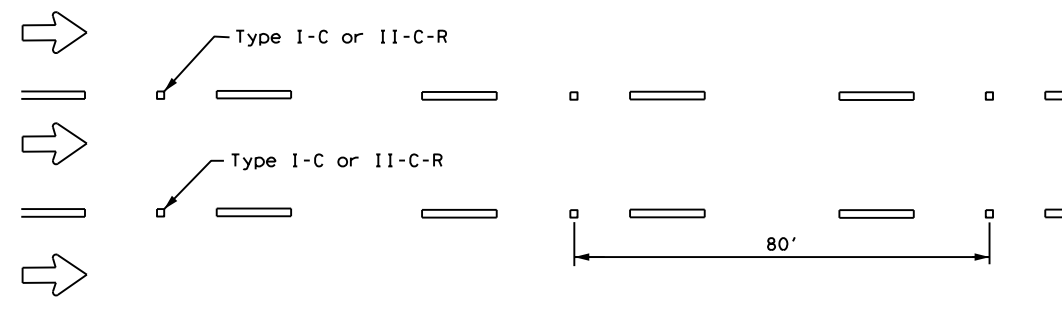

**LANE LINES FOR ONE-WAY ROADWAY (NON-FREEWAY FACILITIES)**

Raised pavement markers Type II-C-R shall have clear face toward normal traffic and red face toward wrong-way traffic.  
 See Note 3.

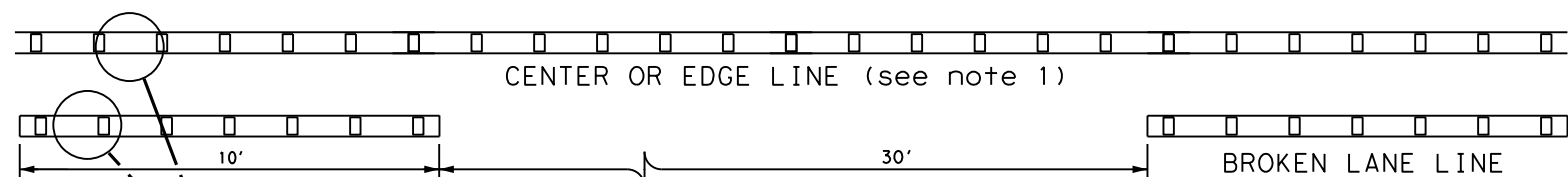

CENTER OR EDGE LINE (see note 1)

BROKEN LANE LINE

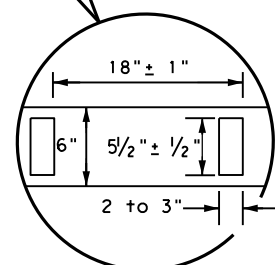

6" EDGE LINE, 6" CENTERLINE  
OR 6" LANE LINE

**REFLECTORIZED PROFILE  
PATTERN DETAIL**

USING REFLECTIVE PROFILE PAVEMENT MARKINGS

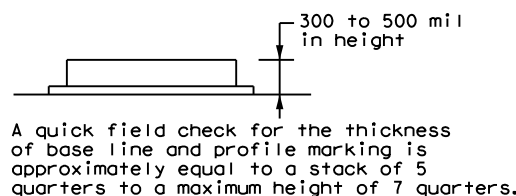

**NOTES**

1. Edge lines should typically be 6" wide and the materials shall be specified in the plans.
2. Profile markings shall not be placed on roadways with a posted speed limit of 45 MPH or less.

**GENERAL NOTES**

1. All raised pavement markers placed along broken lines shall be placed in line with and midway between the stripes.
2. On concrete pavements the raised pavement markers should be placed to one side of the longitudinal joints.
3. Use raised pavement marker Type I-C with undivided roadways, flush medians and two way left turn lanes. Use raised pavement marker Type II-C-R with divided highways and raised medians.

MATERIAL SPECIFICATIONS	
PAVEMENT MARKERS (REFLECTORIZED)	DMS-4200
EPOXY AND ADHESIVES	DMS-6100
BITUMINOUS ADHESIVE FOR PAVEMENT MARKERS	DMS-6130
TRAFFIC PAINT	DMS-8200
HOT APPLIED THERMOPLASTIC	DMS-8220
PERMANENT PREFABRICATED PAVEMENT MARKINGS	DMS-8240

All pavement marking materials shall meet the required Departmental Material Specifications as specified by the plans.

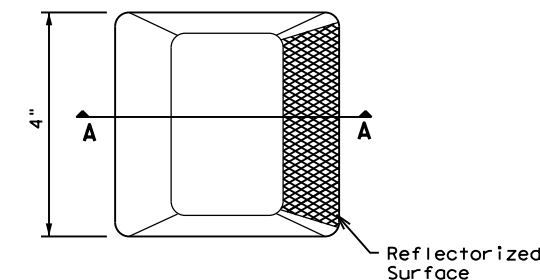

**Type I (Top View)**

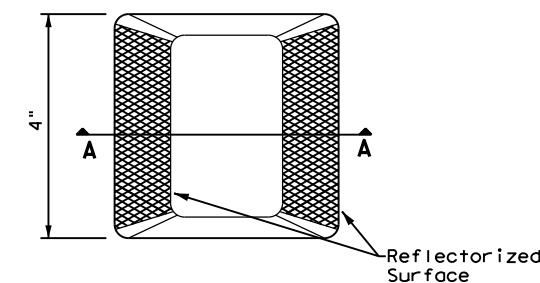

**Type II (Top View)**

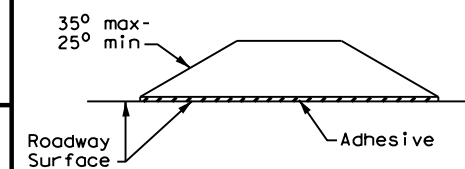

**SECTION A**

**RAISED PAVEMENT MARKERS**



**POSITION GUIDANCE USING  
RAISED MARKERS  
REFLECTORIZED PROFILE  
MARKINGS  
PM(2) - 22**

FILE: pm2-22.dgn	DN:	CK:	DW:	CK:
© TxDOT December 2022	CONT	SECT	JOB	HIGHWAY
REVISIONS	0918	00	392	VA
4-77 8-00 6-20	DIST	COUNTY	SHEET NO.	
4-92 2-10 12-22	DAL	DALLAS, ETC.	93	
5-00 2-12				

DATE: FILE:

DISCLAIMER: The use of this standard is governed by the "Texas Engineering Practice Act". No warranty of any kind is made by TxDOT for any purpose whatsoever. TxDOT assumes no responsibility for the conversion of this standard to other formats or for incorrect results or damages resulting from its use.

DATE: FILE:

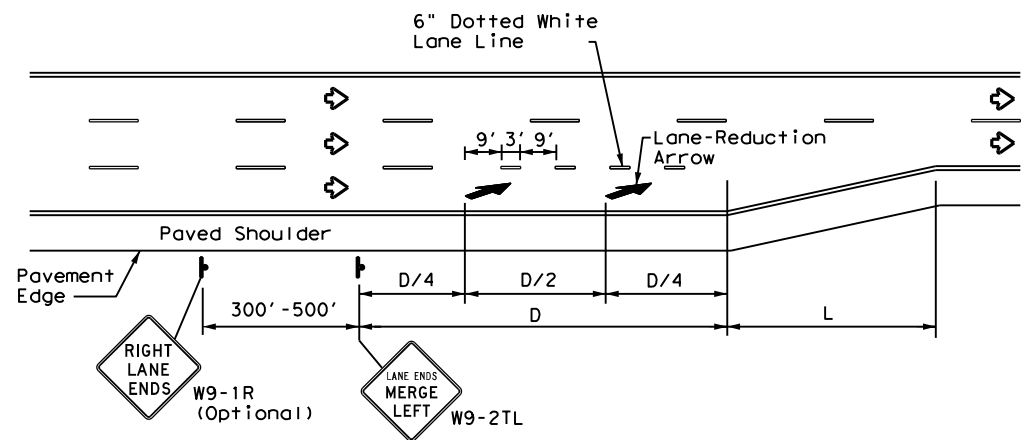

**LANE REDUCTION**

**NOTES**

- Lane reduction pavement markings are used where the number of through lanes is reduced because of narrowing of the roadway or because of a section of on-street parking in what would otherwise be a through lane. For Texas Super 2 Passing Lanes, see TS2(PL) standard sheets.
- On divided highways, an additional RIGHT LANE ENDS (W9-1R) sign may be installed in the median aligned with the W9-1R sign on the right side of the highway.
- Lane reduction arrows are required for speeds of 45 mph or greater. An optional third lane reduction arrow may be added based on engineering judgement. If used, the optional third lane reduction arrow should be centered between the first and last lane reduction arrows.
- For lane reductions on Freeways and Expressways, signing shall conform to the TxDOT Freeway Signing Handbook.

ADVANCED WARNING SIGN DISTANCE (D)		
Posted Speed	D (ft)	L (ft)
30 MPH	460	$L = \frac{WS^2}{60}$
35 MPH	565	
40 MPH	670	
45 MPH	775	L=WS
50 MPH	885	
55 MPH	990	
60 MPH	1,100	
65 MPH	1,200	
70 MPH	1,250	
75 MPH	1,350	

**GENERAL NOTES**

- Lane use word and arrow markings shall be used where through lanes approaching an intersection become mandatory turn lanes. Lane use word and arrow markings should be used in auxiliary lanes of substantial length. Lane use arrow markings or word and arrow markings may be used in other lanes and turn bays for emphasis. Details for words and arrows are as shown in the Standard Highway Sign Designs for Texas.
- When lane-use words and arrow markings are used, two sets of arrows should be used if the length of the bay is greater than 180 feet. When a single lane use arrow or word and arrow marking is used for a short turn lane, it should be located at or near the upstream end of the full-width turn lane.
- Use raised pavement marker Type I-C with undivided highways, flush medians and two way left turn lanes. Use raised pavement marker Type II-C-R with divided highways and raised medians.
- Length of turn bays, including taper, deceleration, and storage lengths shall be as shown on the plans or as directed by the Engineer. See Chapter 3 of the Roadway Design Manual for additional information on turning lanes or storage lengths.

MATERIAL SPECIFICATIONS	
PAVEMENT MARKERS (REFLECTORIZED)	DMS-4200
EPOXY AND ADHESIVES	DMS-6100
BITUMINOUS ADHESIVE FOR PAVEMENT MARKERS	DMS-6130
TRAFFIC PAINT	DMS-8200
HOT APPLIED THERMOPLASTIC	DMS-8220
PERMANENT PREFABRICATED PAVEMENT MARKINGS	DMS-8240

All pavement marking materials shall meet the required Departmental Material Specifications as specified by the plans.

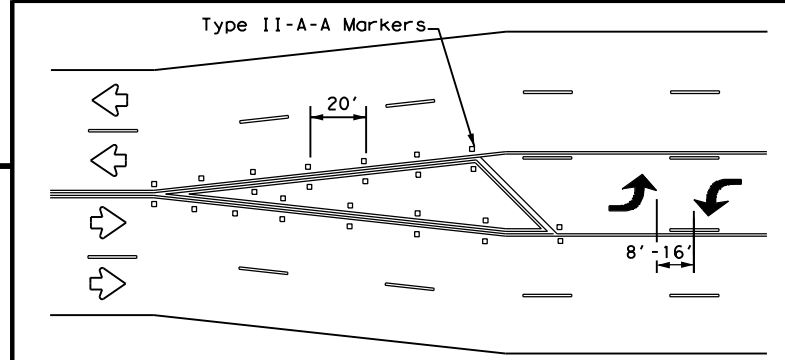

A two-way left-turn (TWLTL) lane-use arrow pavement marking should be used at or just downstream from the beginning of a two-way left-turn lane within a corridor. Repeating the marking after each intersection or dedicated turn bay is not required unless stated elsewhere in the plans.

**TYPICAL TRANSITION FOR TWLTL AND DIVIDED HIGHWAY**

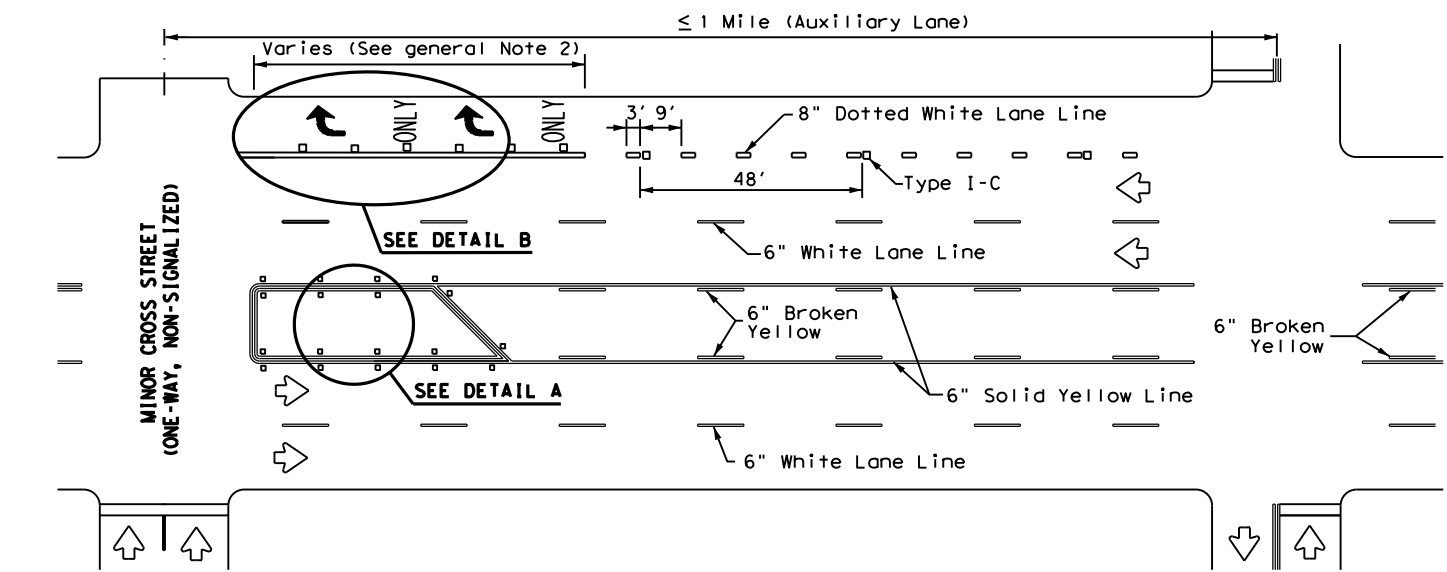

**TYPICAL TWLTL AT ONE-WAY STREET AND RIGHT TURN AUXILIARY LANE**

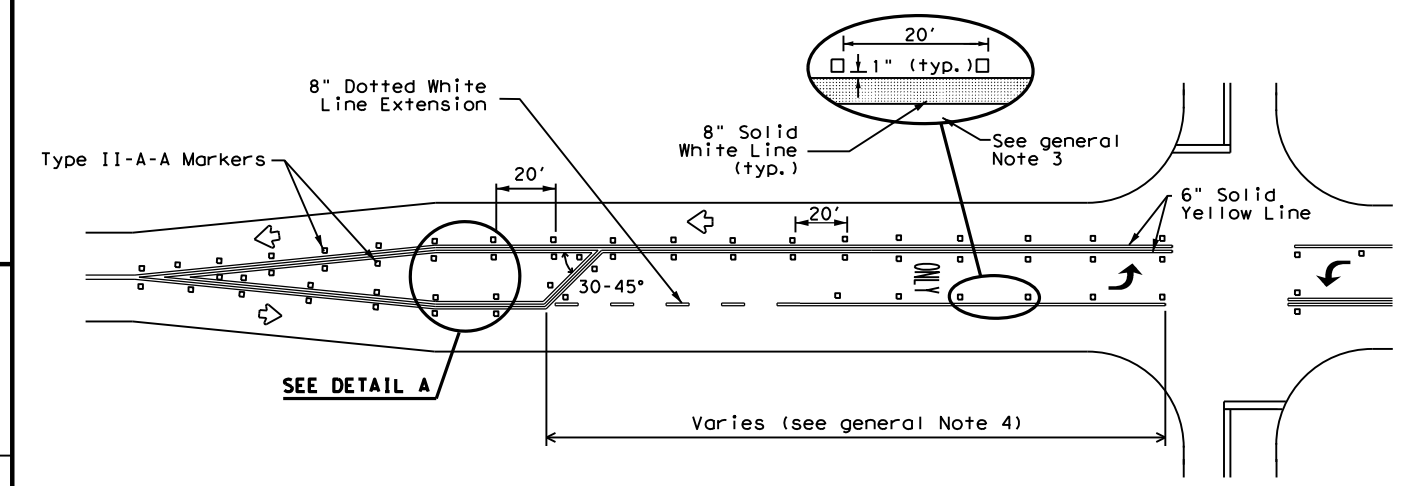

**TYPICAL TWO-LANE ROADWAY INTERSECTION WITH LEFT TURN BAYS**

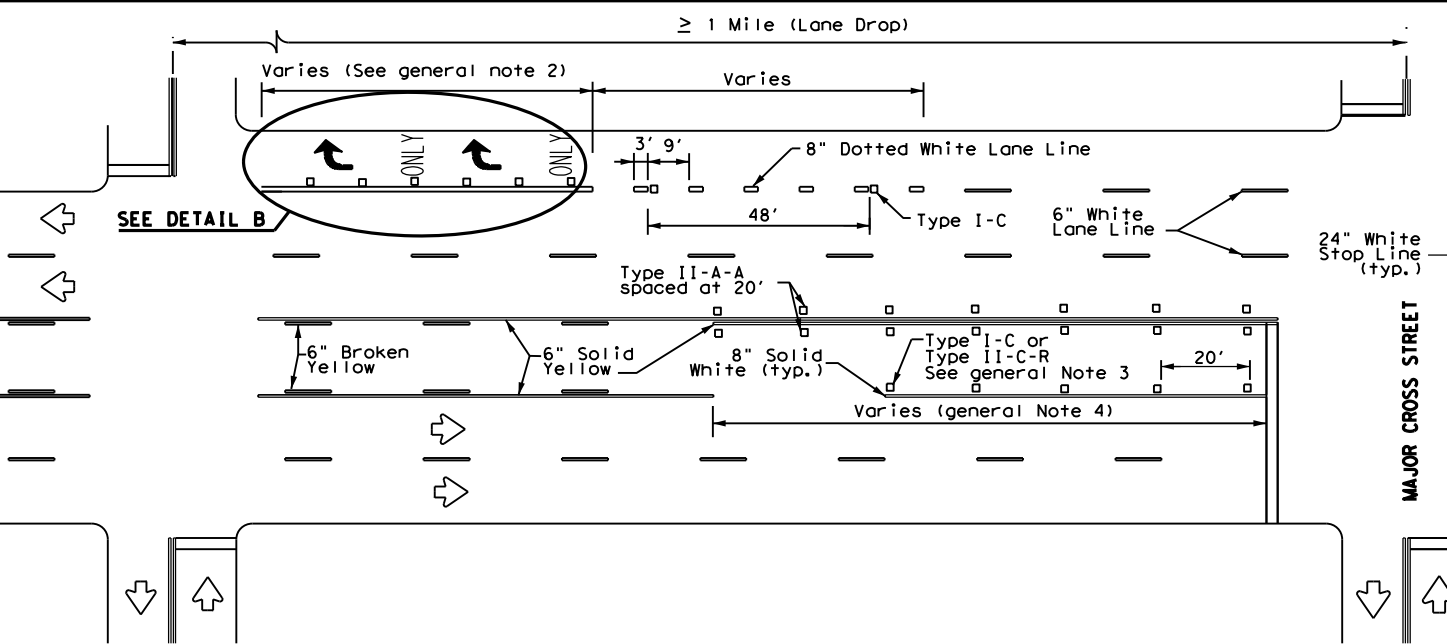

**TYPICAL TWLTL AT TWO-WAY CROSS STREET AND RIGHT TURN LANE DROP**

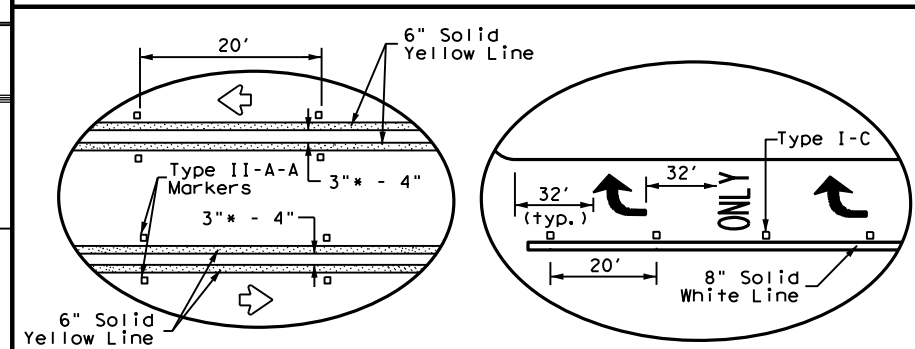

**DETAIL A**

**DETAIL B**

\* 2" minimum allowed for restripe projects when approved by the Engineer.

Texas Department of Transportation  
Traffic Safety Division Standard

**TWO-WAY LEFT TURN LANES, RURAL LEFT TURN BAYS, AND LANE REDUCTION PAVEMENT MARKINGS PM(3) - 22**

FILE: pm3-22.dgn	DN:	CK:	DW:	CK:
© TxDOT December 2022	CONT	SECT	JOB	HIGHWAY
REVISIONS	0918	00	392	VA
4-98 3-03 6-20	DIST	COUNTY	SHEET NO.	
5-00 2-10 12-22	DAL	DALLAS, ETC.	94	
8-00 2-12				

DISCLAIMER: The use of this standard is governed by the "Texas Engineering Practice Act". No warranty of any kind is made by TxDOT for any purpose whatsoever. TxDOT assumes no responsibility for the conversion of this standard to other formats or for incorrect results or damages resulting from its use.

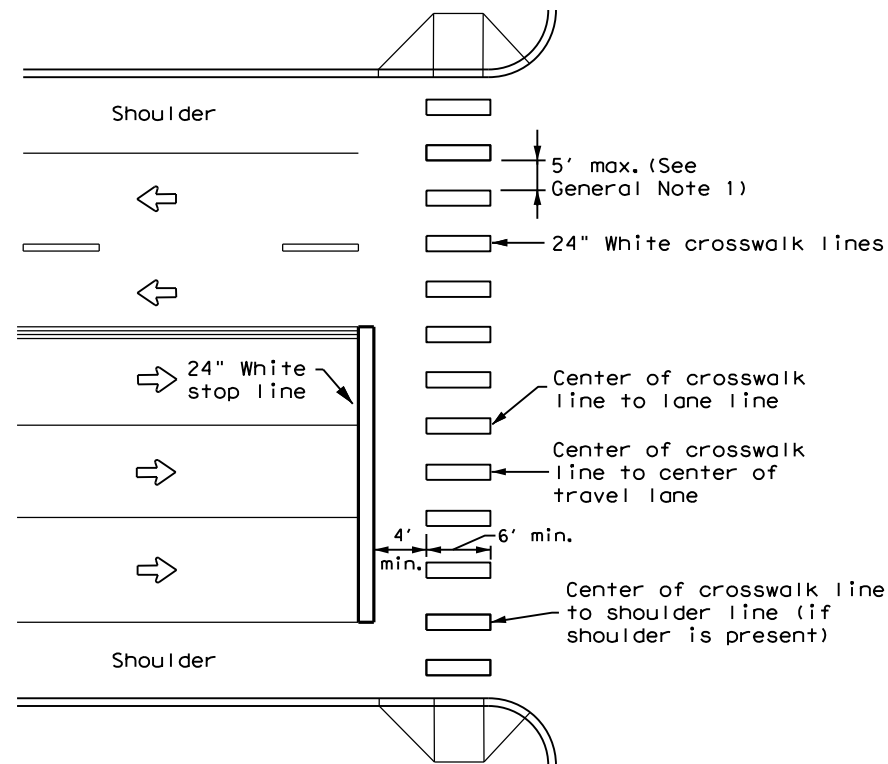

**HIGH-VISIBILITY LONGITUDINAL CROSSWALK AT CONTROLLED APPROACH**

**GENERAL NOTES**

1. Longitudinal crosswalk lines should not be placed in the wheel path of vehicles. Center the crosswalk lines on travel lanes, lane lines, and shoulder lines (if present).
2. A minimum 6" clear distance shall be provided to the curb face. If the last crosswalk line falls into this distance it must be omitted.
3. For divided roadways, adjustments in spacing of the crosswalk lines should be made in the median so that the crosswalk lines are maintained in their proper location across the travel portion of the roadway.
4. At skewed crosswalks, the crosswalk lines are to remain parallel to the lane lines.
5. Each crosswalk shall be a minimum of 6' wide.
6. The High-Visibility Longitudinal Crosswalk is the preferred crosswalk pattern on State Highways. Other crosswalk patterns as shown in the "Texas Manual on Uniform Traffic Control Devices" may be used. All crosswalk designs and dimension shall comply with the "Texas Manual on Uniform Traffic Control Devices."
7. Final placement of Stop Bar and Crosswalk shall be approved by the Engineer in the field.

MATERIAL SPECIFICATIONS	
PAVEMENT MARKERS (REFLECTORIZED)	DMS-4200
EPOXY AND ADHESIVES	DMS-6100
BITUMINOUS ADHESIVE FOR PAVEMENT MARKERS	DMS-6130
TRAFFIC PAINT	DMS-8200
HOT APPLIED THERMOPLASTIC	DMS-8220
PERMANENT PREFABRICATED PAVEMENT MARKINGS	DMS-8240

All pavement marking materials shall meet the required Departmental Material Specifications as specified by the plans.

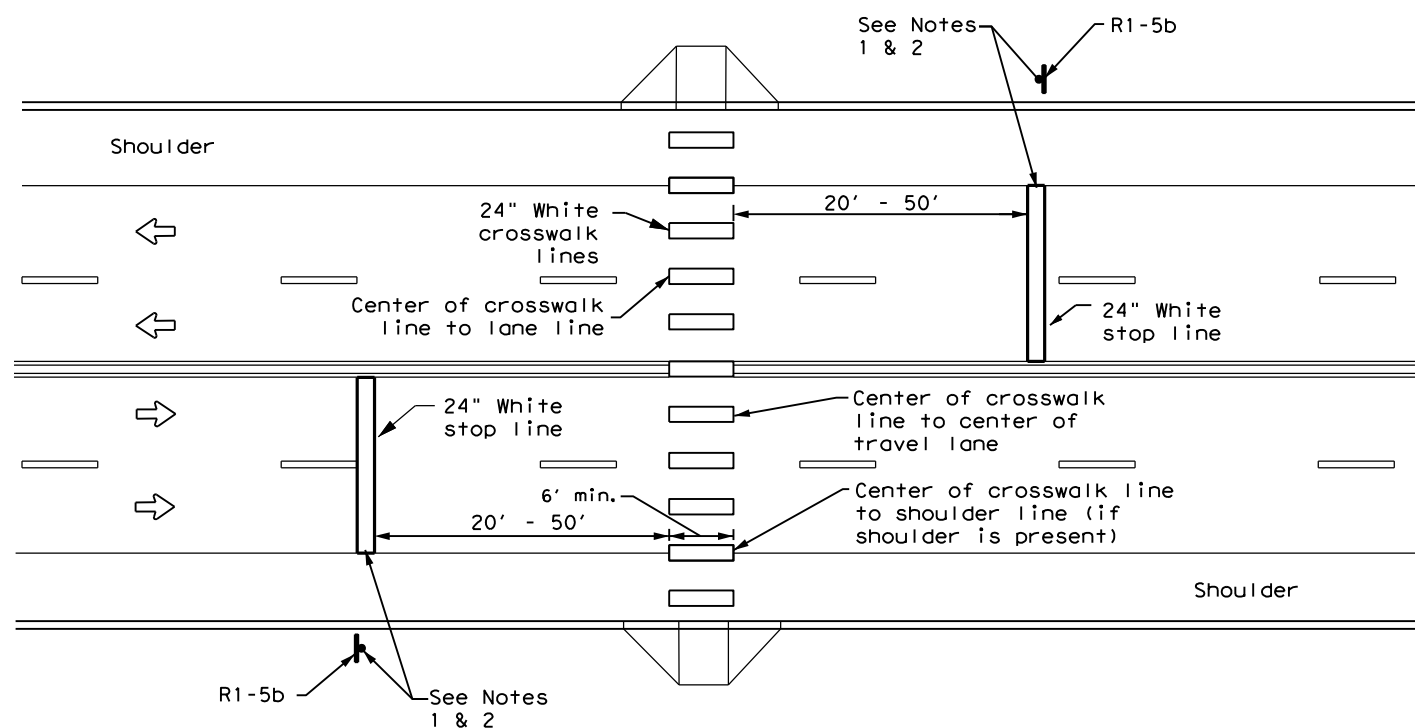

**UNSIGNALIZED MIDBLOCK HIGH-VISIBILITY LONGITUDINAL CROSSWALK**

**NOTES:**

1. Use stop bars with Stop Here For Pedestrians (R1-5b) signs at unsignalized midblock crosswalks.
2. Use stop bars with STOP HERE ON RED (R10-6 or R10-6a) signs at midblock crosswalks controlled by traffic signals or pedestrian hybrid beacons.

<p><b>CROSSWALK PAVEMENT MARKINGS</b></p> <p><b>PM(4) - 22A</b></p>			
FILE: pm4-22a.dgn	DN:	CK:	DW:
© TxDOT December 2022	CONT: 0918	SECT: 00	JOB: 392
REVISIONS:	DIST: DAL	COUNTY: DALLAS, ETC.	HIGHWAY: VA
6-20			SHEET NO. 95
6-22			
12-22			
22D			

DATE:  
FILE:

DISCLAIMER: The use of this standard is governed by the "Texas Engineering Practice Act". No warranty of any kind is made by TxDOT for any purpose whatsoever. TxDOT assumes no responsibility for the conversion of this standard to other formats or for incorrect results or damages resulting from its use.

DATE: 2/20/2024 12:48:54 PM  
 FILE: U:\TRAFFIC PROJECTS\0918-00-392 Non-Site 9-24\Microstation Files\096.dgn

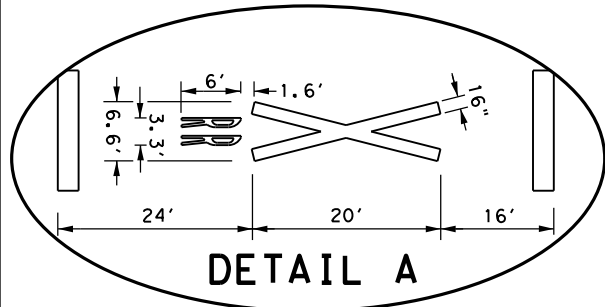
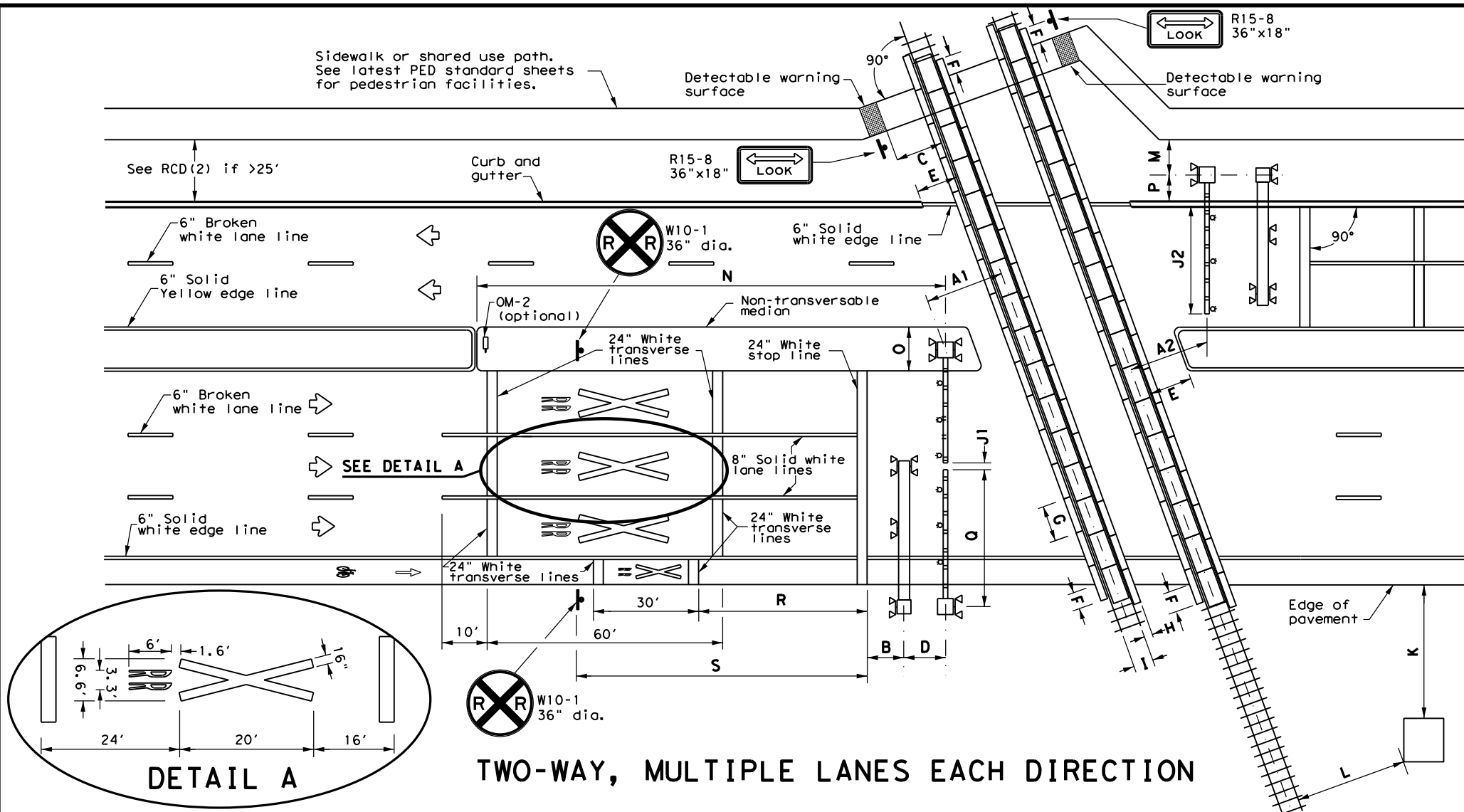

**TWO-WAY, MULTIPLE LANES EACH DIRECTION**

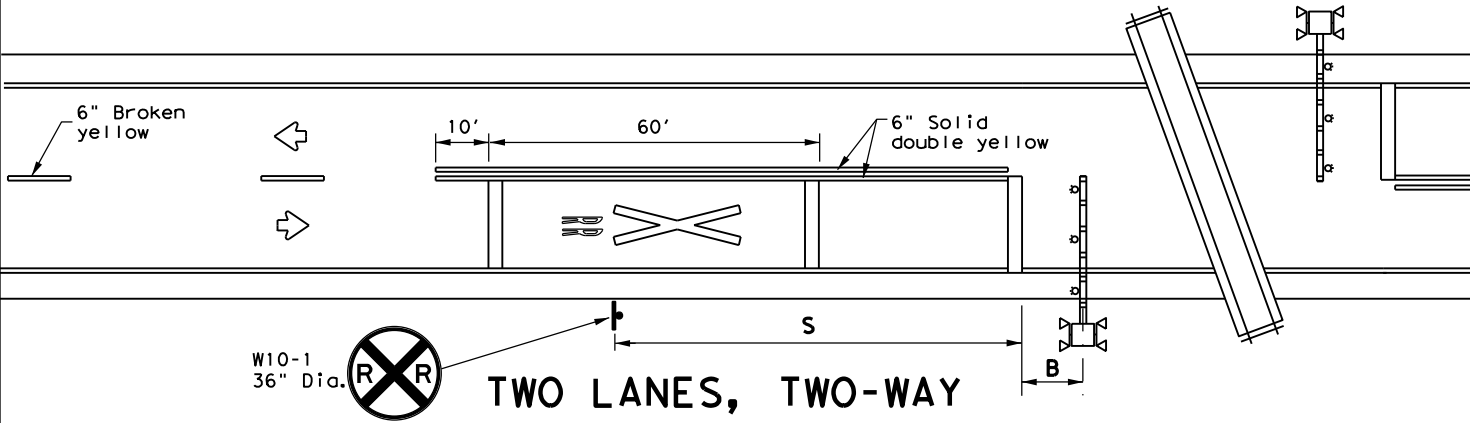

**TWO LANES, TWO-WAY**

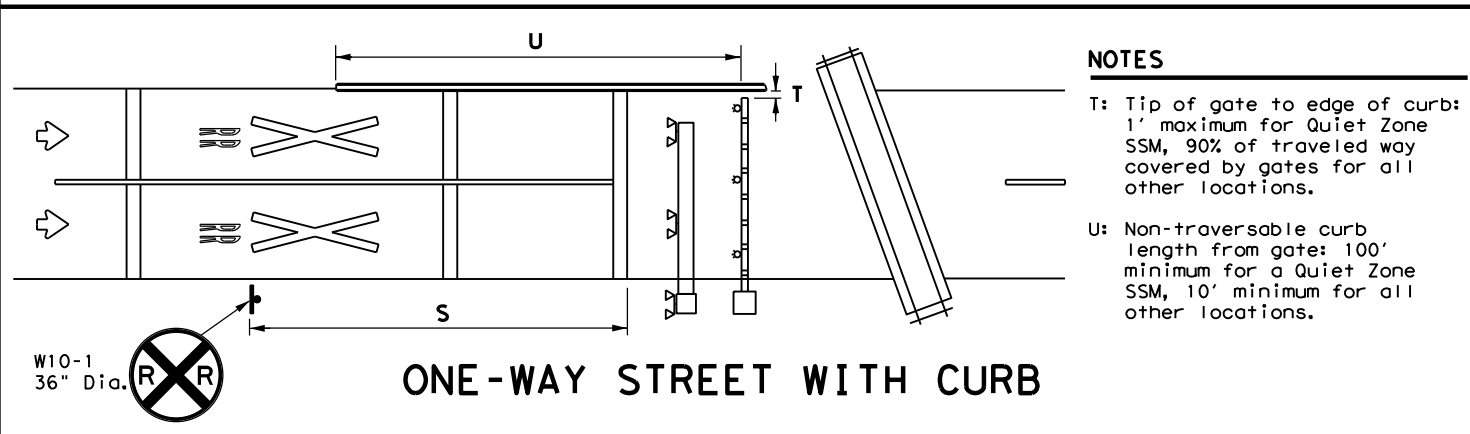

**ONE-WAY STREET WITH CURB**

- NOTES**
- T: Tip of gate to edge of curb: 1' maximum for Quiet Zone SSM, 90% of traveled way covered by gates for all other locations.
  - U: Non-transversible curb length from gate: 100' minimum for a Quiet Zone SSM, 10' minimum for all other locations.

**TABLE 1**

Approach Speed (mph)	Desirable Placement (feet)
20	100
25	100
30	100
35	100
40	125
45	175
50	250
55	325
60	400
65	475
70	550
75	650

**LEGEND**

	Sign
	Object Marker
	Traffic Flow
	Cantilever
	Gate Assembly
	Mast Flasher Pair

- GENERAL NOTES**
- Medians and curbs must be non-traversable to qualify as a Quiet Zone Supplementary Safety Measure (SSM). Non-traversable curbs in Quiet Zones are 6" tall minimum and used on roadways where speed does not exceed 40 mph.
  - Raised pavement markers may be used to supplement striping. See PM(2) and PM(3) standard sheets.
  - Medians preferred whenever possible to prevent vehicles from driving around gates.
  - Longitudinal edge striping may be continued thru crossing as needed. Illumination may also be considered for nighttime visibility.
  - See SMD standard sheets for sign mounting details.
  - See the Standard Highway Sign Design for Texas (SHSD) manual for sign and pavement marking details.

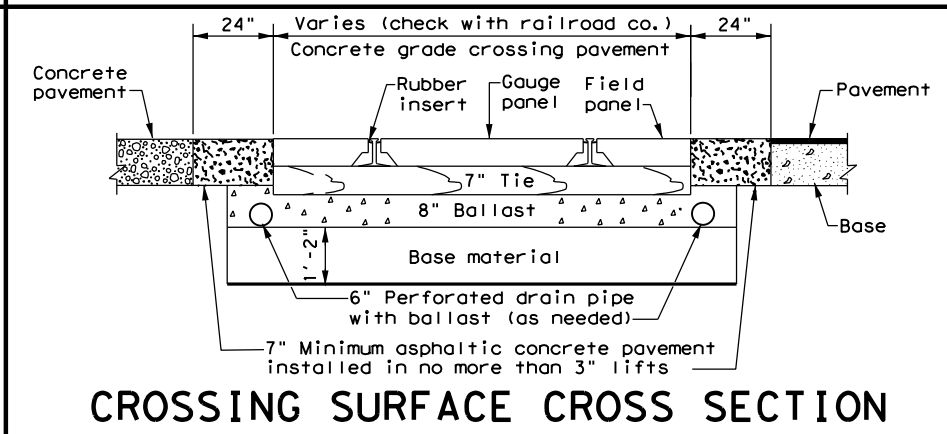

**CROSSING SURFACE CROSS SECTION**

- NOTES**
- A1: Center of RR mast to center of rail: 12' minimum, 15' typical.
  - A2: Tip of gate to center of rail: 12' minimum, 15' typical.
  - B: Center of mast (cantilever, gate, or mast flasher) of nearest active traffic control device to stop line: 8' (NOTE: Stop line may be moved as needed, but should be at least 8' back from gates, if present).
  - C: Near edge of detectable warning surface to nearest rail: 12' minimum.
  - D: Center of gate mast to center of cantilever mast: 6' typical. NOTE: Cantilever may be located in front or behind gates.
  - E: Edge of median or curb to nearest rail: 10' typical. NOTE: Design median edge to be parallel with rail.
  - F: Edge of planking panel from edge of pavement or sidewalk: 3' minimum. NOTE: Field panels need not be in line with gauge panels.
  - G: Length of panels along rail: 8' typical.
  - H: Width of field panel: 2' typical (check with railroad company).
  - I: Distance between rails: 4'- 8'1/2".
  - J1: Tip of gate to tip of gate: 2' maximum.
  - J2: 90% of traveled roadway to be covered by gate.
  - K: Nearest edge of RR cabinet from edge of pavement: 30' typical. NOTE: Cabinet not required to be parallel to edge of pavement.
  - L: Nearest edge of RR cabinet from nearest rail: 25' typical.
  - M: Center of RR mast to edge of sidewalk: 6' minimum.
  - N: Center of gate mast to leading edge of non-traversable median: 100' minimum to qualify as a Quiet Zone SSM. NOTE: 60' will suffice if there is a street intersection within the 100' and all street intersections within 60' are closed.
  - O: Width of median for RR gate assembly: 8'-6" minimum, 10' typical when using median gates. NOTE: Center of gate mast minimum 4'-3" from face of curb.
  - P: Center of RR mast to face of curb: 5'-3" minimum. Center of RR mast to edge of pavement (with shoulder): 7' minimum. Center of RR mast to edge of pavement (no shoulder): 9'-3" minimum. NOTE: Final location determined by the railroad company.
  - Q: Gate length: 28' or less typical, but railroad company may allow up to 32' under special circumstances.
  - R: Stop line to first RR Crossing transverse line (bike lane): 50' typical.
  - S: Stop line to GRADE CROSSING ADVANCE WARNING (W10-1) sign and adjacent RR Crossing pavement markings. See Table 1. See RCD(2) for other signs.

Texas Department of Transportation  
 Traffic Safety Division Standard

**RAILROAD CROSSING DETAILS  
 SIGNING, STRIPING, AND  
 DEVICE PLACEMENT  
 RCD(1)-22**

FILE: rcd1-22.dgn	DN: TxDOT	CK: TxDOT	DW: TxDOT	CK: TxDOT
© TxDOT November 2022	CONT	SECT	JOB	HIGHWAY
REVISIONS	0918	00	392	VA
2-16	DIST	COUNTY	SHEET NO.	
11-22	DAL	DALLAS, ETC.	96	



DATE: 2/20/2024 12:49:26 PM  
 FILE: U:\TRAFFIC PROJECTS\0918-00-392 Non-Site 9-24\Microstation Files\0918-00-392.dgn  
 The use of this standard is governed by the "Texas Engineering Practice Act". No warranty of any kind is made by TxDOT for any purpose whatsoever. TxDOT assumes no responsibility for the conversion of this standard to other formats or for incorrect results or damages resulting from its use.

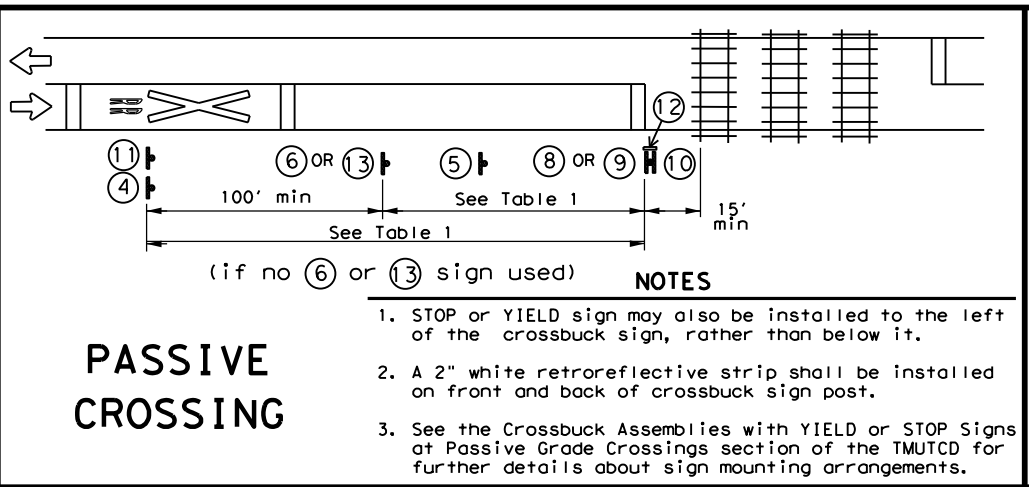

### PASSIVE CROSSING

- NOTES**
1. STOP or YIELD sign may also be installed to the left of the crossbuck sign, rather than below it.
  2. A 2" white retroreflective strip shall be installed on front and back of crossbuck sign post.
  3. See the Crossbuck Assemblies with YIELD or STOP Signs at Passive Grade Crossings section of the TMUTCD for further details about sign mounting arrangements.

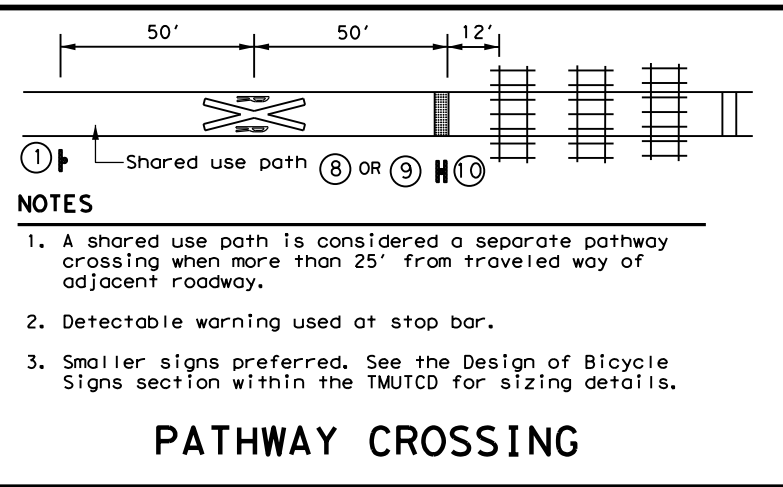

### PATHWAY CROSSING

- NOTES**
1. A shared use path is considered a separate pathway crossing when more than 25' from traveled way of adjacent roadway.
  2. Detectable warning used at stop bar.
  3. Smaller signs preferred. See the Design of Bicycle Signs section within the TMUTCD for sizing details.

TABLE 1	
Approach Speed (mph)	Desirable Placement (feet)
20	100
25	100
30	100
35	100
40	125
45	175
50	250
55	325
60	400
65	475
70	550
75	650

- GENERAL NOTES**
1. Railroad company to provide active traffic control devices, CROSSBUCK (R15-1), NUMBER OF TRACKS (R15-2P) plaque (if more than 1 track), and EMERGENCY NOTIFICATION (I-13) signs.
  2. LOW GROUND CLEARANCE (W10-5) signs may be relocated further upstream of crossing to provide advance warning of alternate route.
  3. GRADE CROSSING AND INTERSECTION ADVANCE WARNING (W10-2) signs may be modified as needed to fit roadway geometry.
  4. Table 1 placement distances may vary per the Placement of Warning Signs section of the TMUTCD.
  5. See Table 1 to determine placement of STOP AHEAD (W3-1) and YIELD AHEAD (W3-2) signs unless shown otherwise.
  6. DO NOT STOP ON TRACKS (R8-8) signs installed when potential for vehicles stopping on tracks is significant as determined by sealing engineer. Install so sign does not block view of RR mast.
  7. See the Standard Highway Sign Design for Texas (SHSD) manual for sign and pavement marking details.

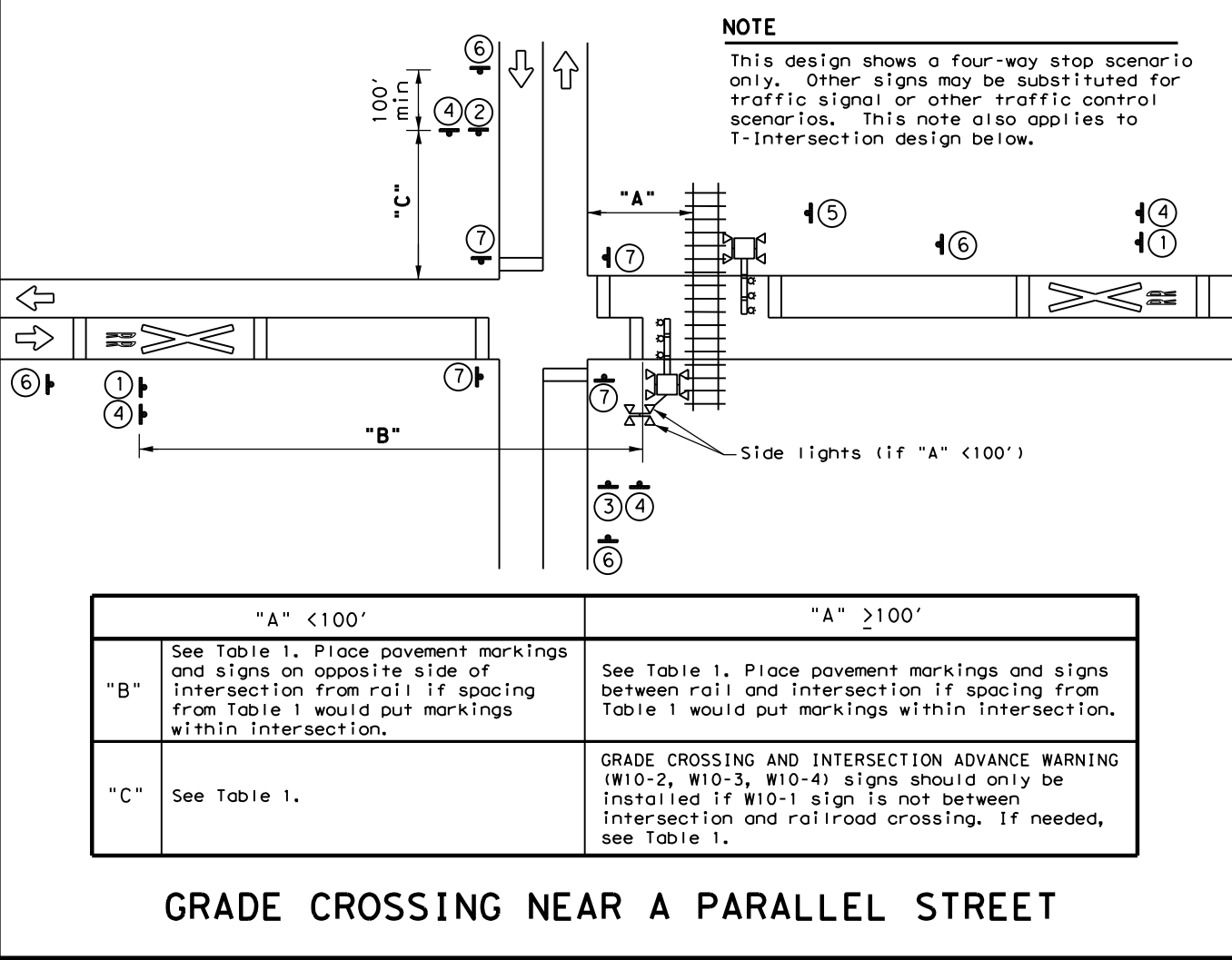

**NOTE**  
 This design shows a four-way stop scenario only. Other signs may be substituted for traffic signal or other traffic control scenarios. This note also applies to T-Intersection design below.

	"A" < 100'	"A" ≥ 100'
"B"	See Table 1. Place pavement markings and signs on opposite side of intersection from rail if spacing from Table 1 would put markings within intersection.	See Table 1. Place pavement markings and signs between rail and intersection if spacing from Table 1 would put markings within intersection.
"C"	See Table 1.	GRADE CROSSING AND INTERSECTION ADVANCE WARNING (W10-2, W10-3, W10-4) signs should only be installed if W10-1 sign is not between intersection and railroad crossing. If needed, see Table 1.

### GRADE CROSSING NEAR A PARALLEL STREET

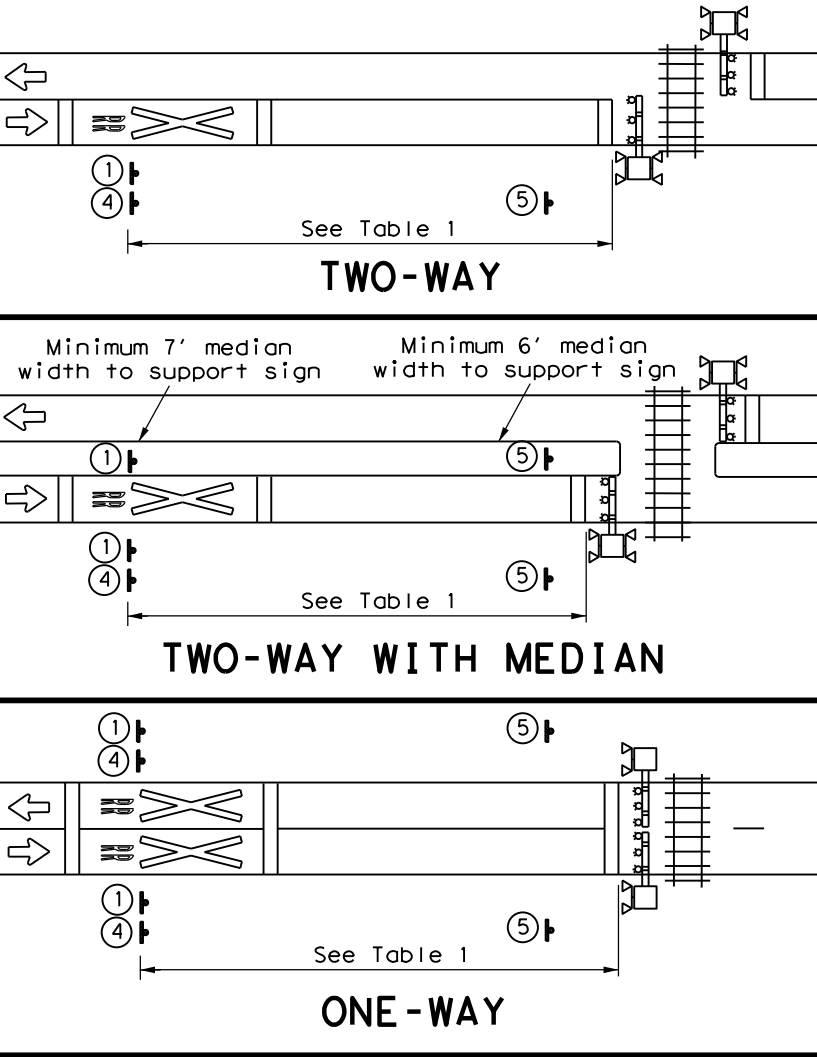

### TWO-WAY

### TWO-WAY WITH MEDIAN

### ONE-WAY

**SIGNS**

 1 W10-1 36" Dia.	 2 W10-2L 36" X 36"	 3 W10-2R 36" X 36"	 IF NEEDED W10-5 36" X 36"  W10-5P 30" X 24"
 5 R8-8 24" X 30"	 6 W3-1 30" X 30"	 IF NEEDED R1-1 36" X 36"  R1-3P 18" X 6"	 R15-1 48" X 9"  R15-2P 27" X 18"  R1-1 36" X 36"
 R15-1 48" X 9"  R15-2P 27" X 18"	 R15-1 48" X 9"  R15-2P 27" X 18"	 W10-1 36" Dia.  W10-13P 30" X 24"	REPORT EMERGENCY OR PROBLEM 1-800-555-5555 CROSSING 836 597 H Sign may be placed perpend. to travel lanes.  I-13 15" X 9"
 13 W3-2 30" X 30"	** Includes a NO TRAIN HORN (W10-9P) plaque if crossing is in a Quiet Zone. If needed, is mounted below W10-2/W10-3/W10-4 signs.  W10-9P 30" X 24"		

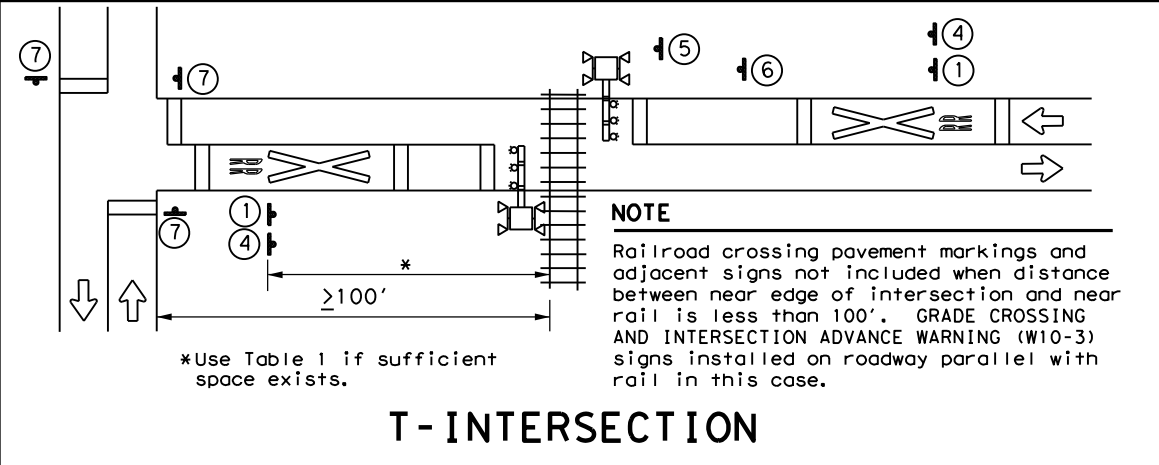

**NOTE**  
 Railroad crossing pavement markings and adjacent signs not included when distance between near edge of intersection and near rail is less than 100'. GRADE CROSSING AND INTERSECTION ADVANCE WARNING (W10-3) signs installed on roadway parallel with rail in this case.

### T-INTERSECTION

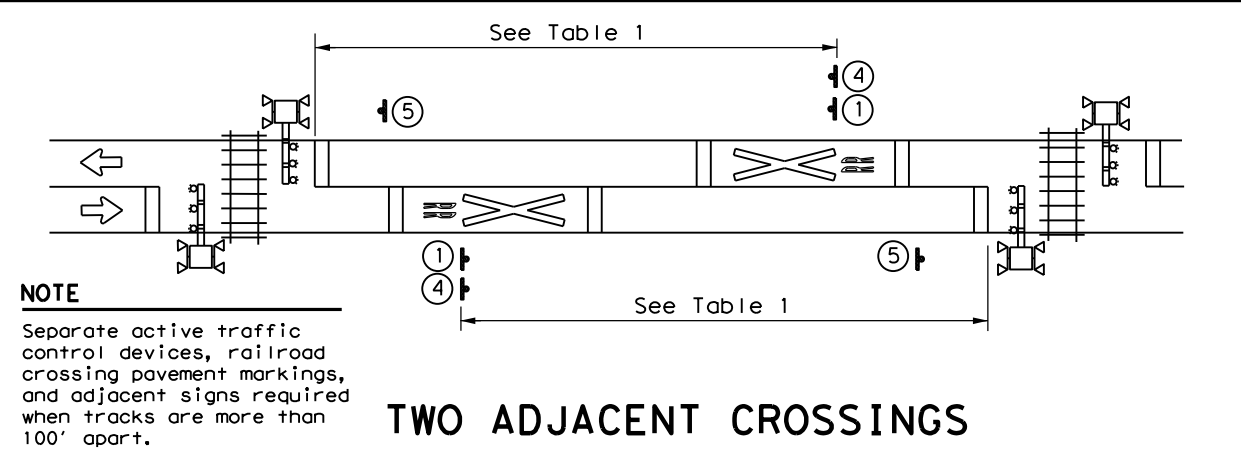

**NOTE**  
 Separate active traffic control devices, railroad crossing pavement markings, and adjacent signs required when tracks are more than 100' apart.

### TWO ADJACENT CROSSINGS

Texas Department of Transportation  
 Traffic Safety Division Standard

## RAILROAD CROSSING DETAILS SIGNING & STRIPING

### RCD(2) - 22

FILE: rcd2-22.dgn	DN: TxDOT	CK: TxDOT	DW: TxDOT	CR: TxDOT
© TxDOT November 2022	CONT	SECT	JOB	HIGHWAY
REVISIONS	0918	00	392	VA
2-16	DIST	COUNTY	SHEET NO.	
11-22	DAL	DALLAS, ETC.	97	

DISCLAIMER: The use of this standard is governed by the "Texas Engineering Practice Act". No warranty of any kind is made by TxDOT for any purpose whatsoever. TxDOT assumes no responsibility for the conversion of this standard to other formats or for incorrect results or damages resulting from its use.

DATE: 2/20/2024 12:59:30 PM  
 U:\TRAFFIC PROJECTS\0918-00-392 Non-Site 9-24\Microstation Files\098 BLPM-10.dgn

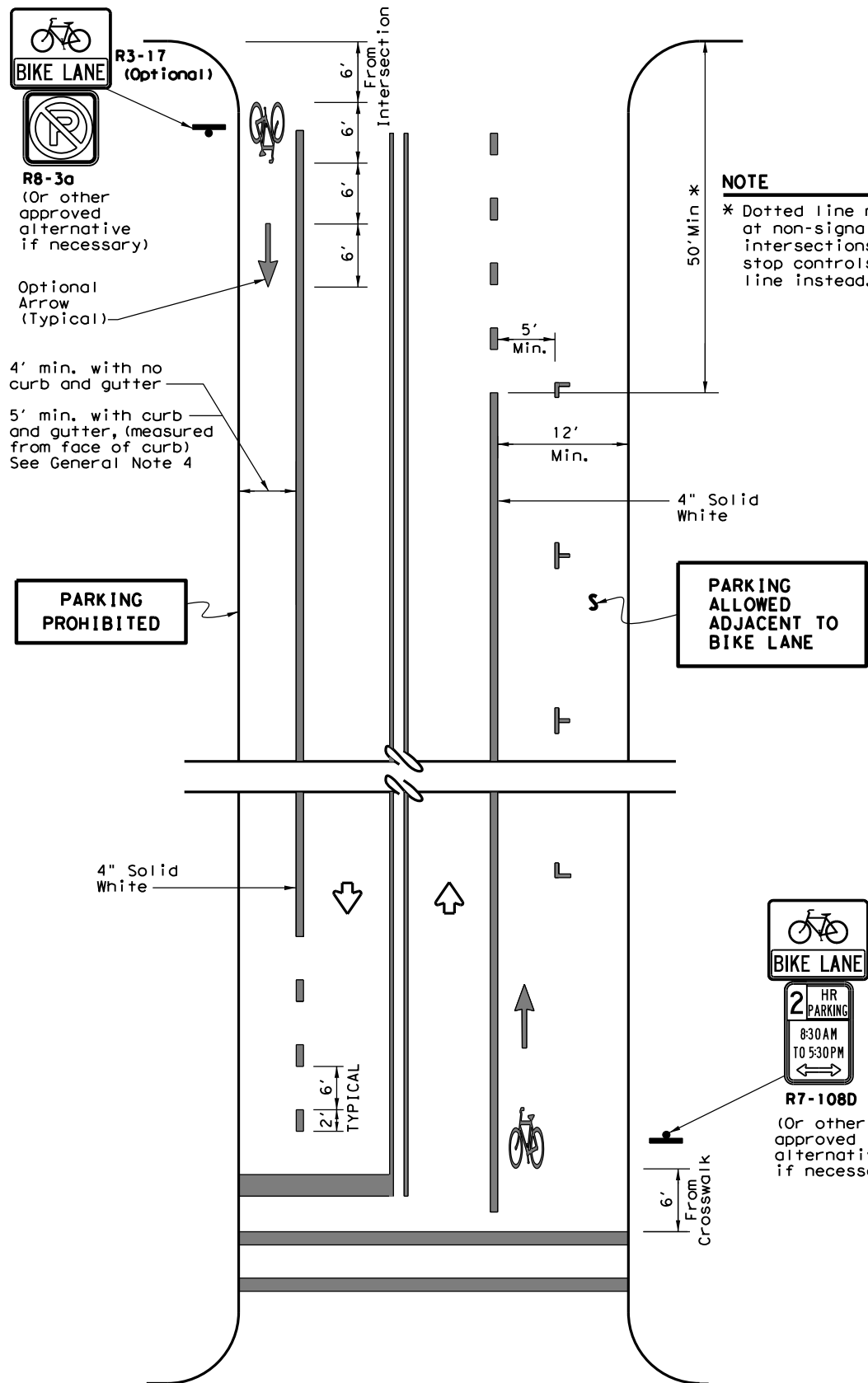

**NOTES**

1. Bicycle lane pavement markings typically repeated after each intersection or signalized driveway.
2. On uninterrupted sections of roadway, bicycle lane pavement markings typically repeated as follows:  
 -1200' for 45 MPH or less roads  
 -2500' for 50 MPH and greater roads.

**TWO-WAY STREET**

**GENERAL NOTES**

1. All bicycle lane pavement markings shall be white unless otherwise noted.
2. All pavement marking materials shall meet the required Department Material Specifications as specified by the plans.
3. Exact sign placement and details are shown elsewhere in the plans.
4. The current edition of AASHTO'S Guide for the Development of Bicycle Facilities should be referenced for variations in design, other geometric conditions, and lane width options.
5. Other bicycle lane symbol or word markings as shown in the Texas Manual on Uniform Traffic Control Devices may be used. Details for words, arrows and symbols as shown in the Standard Highway Sign Designs for Texas.
6. The "BIKE LANE" (R3-17) sign with the "AHEAD" (R3-17a) sign mounted directly below should be installed in advance of the beginning of a marked bike lane.
7. The "BIKE LANE" (R3-17) sign with the "END" (R3-17b) sign mounted directly below should be installed at the end of marked bicycle lane.

**NOTE**

\* Dotted line not necessary at non-signalized minor intersections with no stop controls; Use solid line instead.

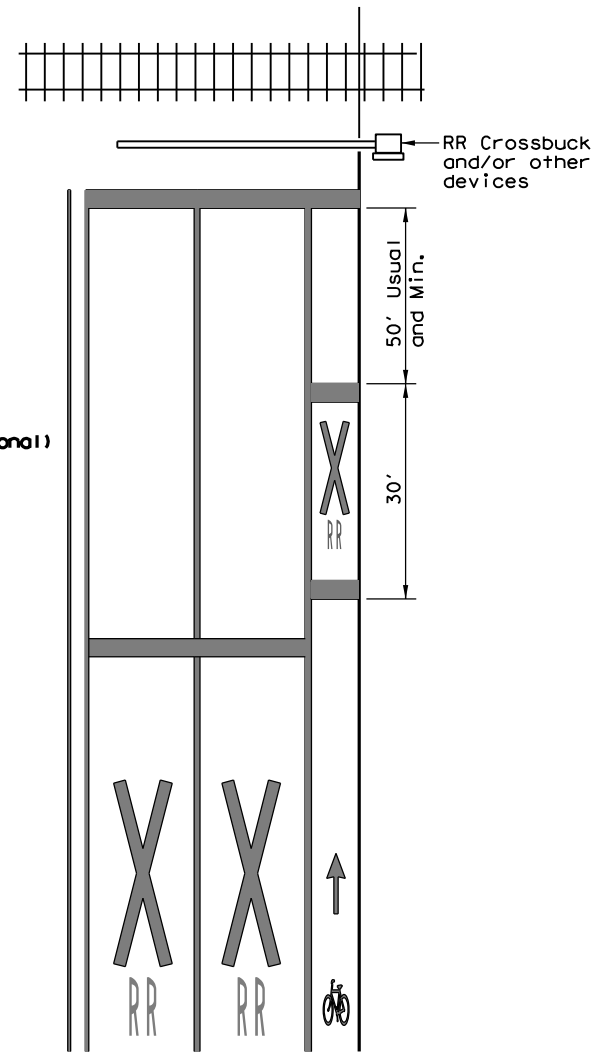

(See RCMP Standard for travel lane details)

**RAILROAD CROSSING APPROACH**

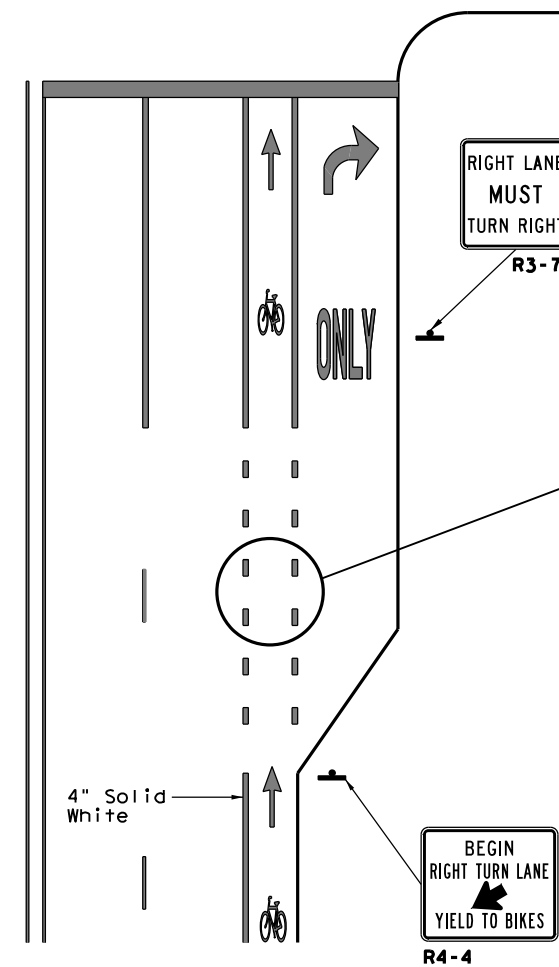

**RIGHT TURN ONLY LANE**

LEGEND	
	Sign
	Traffic Flow

SPECIFICATION REFERENCE TABLE	
Traffic Paint	DMS-8200
Hot Applied Thermoplastic	DMS-8220
Permanent Prefabricated Pavement Markings	DMS-8240
Glass Traffic Beads	DMS-8290

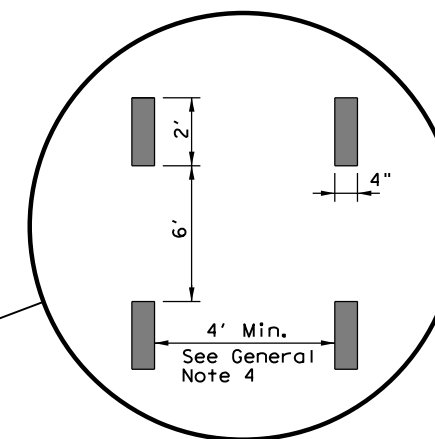

**DETAIL "A"**

Texas Department of Transportation  
 Traffic Operations Division

**BICYCLE LANE  
 PAVEMENT MARKINGS**

**BLPM-10**

© TxDOT	May 2010	DN: TxDOT	CK: TxDOT	DW: TxDOT	CK: TxDOT
REVISIONS		CONT	SECT	JOB	HIGHWAY
		091800		392	VA
		DIST	COUNTY	SHEET NO.	
		DAL	DALLAS, ETC.	98	

NOTES:

1. INSTALL 1/2" ALL THREAD NIPPLE WITH BONDING BUSHINGS ON BOTH ENDS AND 6 EA OF 1/2" X 1/2" 13 UNC MOUNTING BOLTS BETWEEN THE TWO CABINETS (SIGNAL AND BBU).
2. INSTALL 2" FITTING FOR EVP CABLES/WIRES AND 4 EA OF 1/2" X 1/2" 13 UNC MOUNTING BOLTS BETWEEN THE TWO CABINETS (SIGNAL AND EVP).
3. USE SILICON SEALANT TO SEAL BETWEEN THE CABINETS OF THE CONTROLLER, EVP AND BBU UNIT.
4. THE ABOVE WORK PERFORMED AND MATERIALS FURNISHED WILL NOT BE PAID FOR DIRECTLY, BUT WILL BE SUBSIDIARY TO PERTINENT ITEMS.

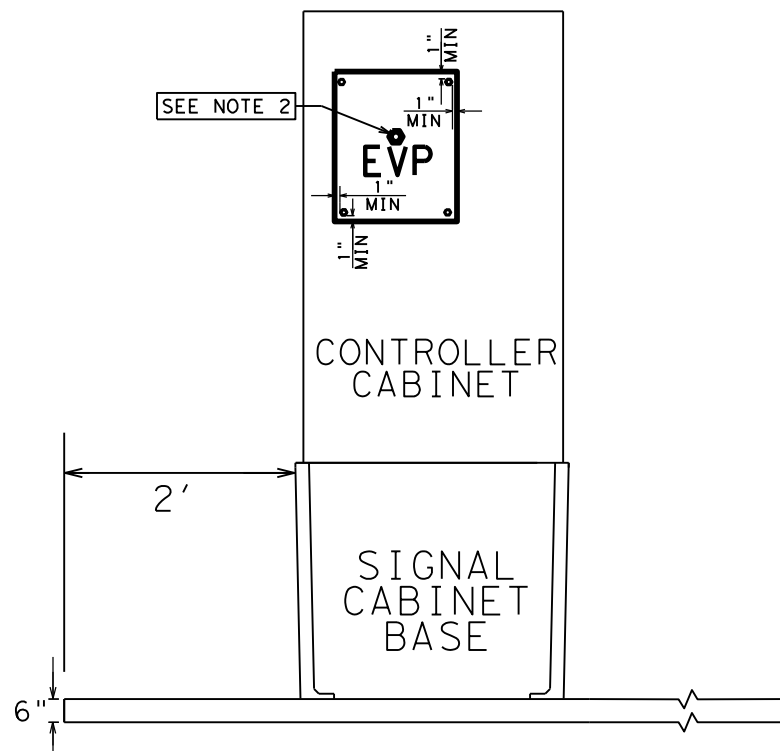

SIDE VIEW  
(EVP)

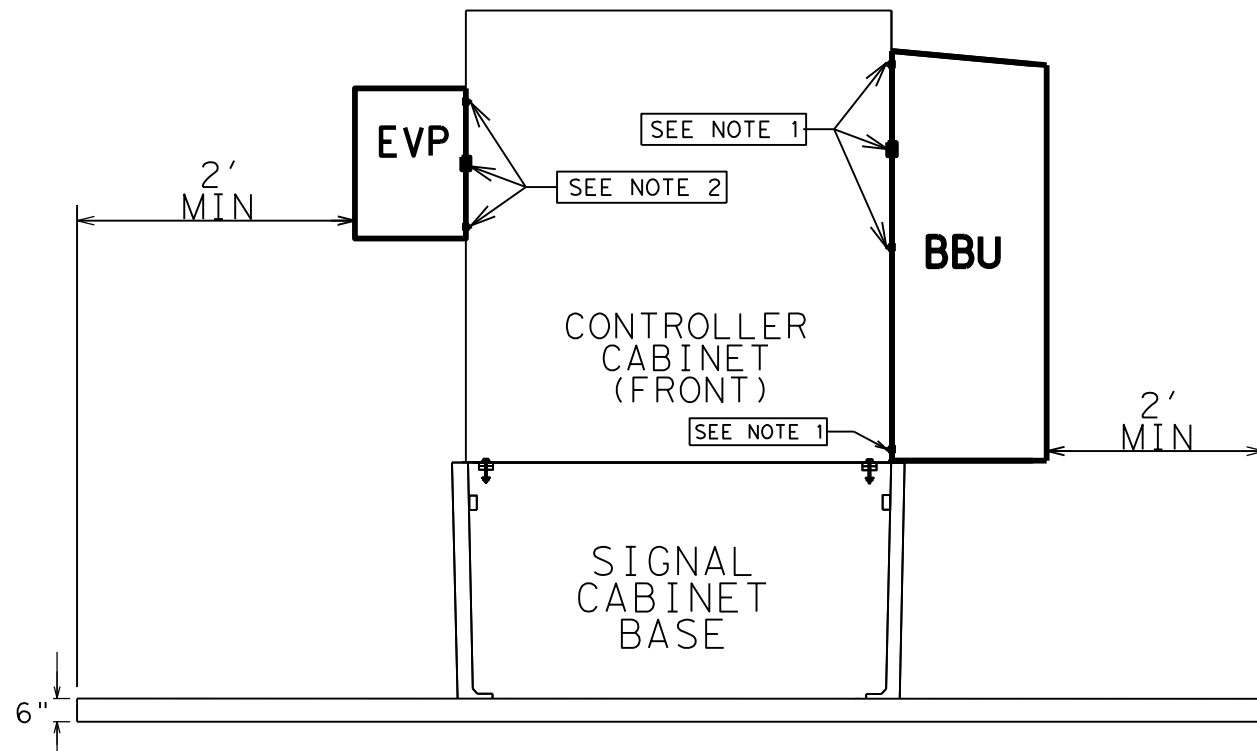

ELEVATION VIEW

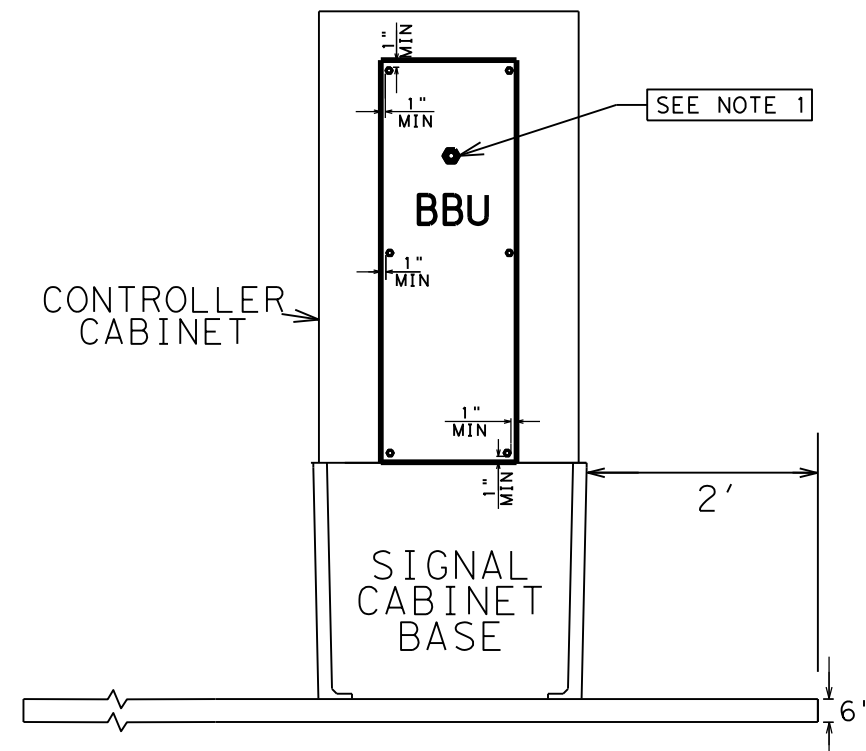

SIDE VIEW  
(BBU)

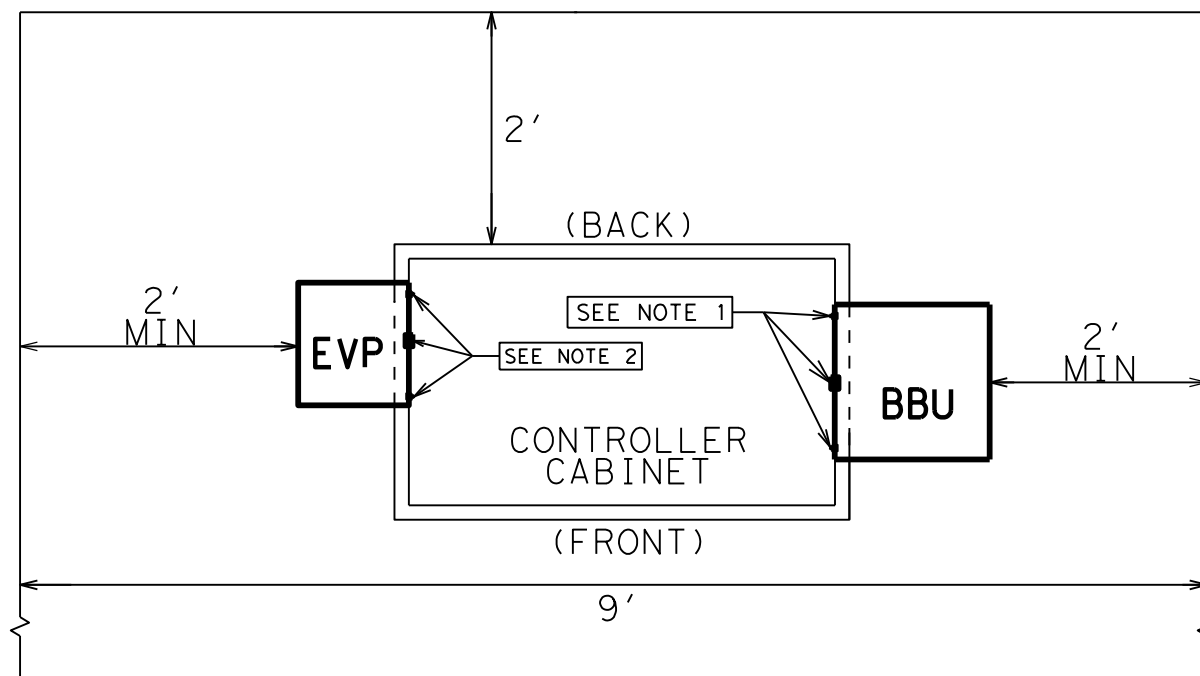

PLAN VIEW

REQUIRED CABLE/CONDUCTORS FOR EVP			
QUANTITY EACH	WIRE SIZE	COLOR	FUNCTION
1	#14	BLACK	120 VAC FOR EVP
1	#14	RED	120 VAC FOR FAN & CABINET LIGHT
1	#14	WHITE	AC NEUTRAL
1	#14	GREEN	CHASIS GROUND
1	#18	GRAY	LOGIC GROUND
4	#18	BLUE	PREEMPT COMMANDS
4	-	-	CABLE FROM DETECTOR UNIT

REQUIRED CONDUCTORS FOR BBU			
QUANTITY EACH	WIRE SIZE	COLOR	FUNCTION
1	-	BLACK	120 VAC FROM SERVICE
1	-	WHITE	AC NEUTRAL FROM SERVICE
1	#6	BLACK	120 VAC TO CONTROLLER
1	#6	WHITE	AC NEUTRAL TO CONTROLLER
1	#6	GREEN	GROUND

LEGEND:

EVP-EMERGENCY VEHICLE PREEMPTION CABINET.  
BBU-BATTERY BACKUP UNIT.

DATE: 2/20/2024 1:04:22 PM  
U:\TRAFFIC PROJECTS\0918-00-392 Non-Site 9-24\Microstation Files\099\_BBU&EVP(1).dgn



**INSTALLATION OF BBU/EVP**  
**EXTERNAL SIDE MOUNT CABINET**  
**INSTALLATION DETAILS**  
**DALLAS DISTRICT STANDARD**

N. T. S.			SHEET 1 OF 3
FED. RD. DIV. NO.	FEDERAL AID PROJECT NO.	HIGHWAY NO.	
6	(SEE TITLE SHEET)	VA	
STATE	DISTRICT	COUNTY	SHEET NO.
TEXAS	DALLAS	DALLAS, ETC.	99
CONTROL	SECTION	JOB	
0918	00	392	

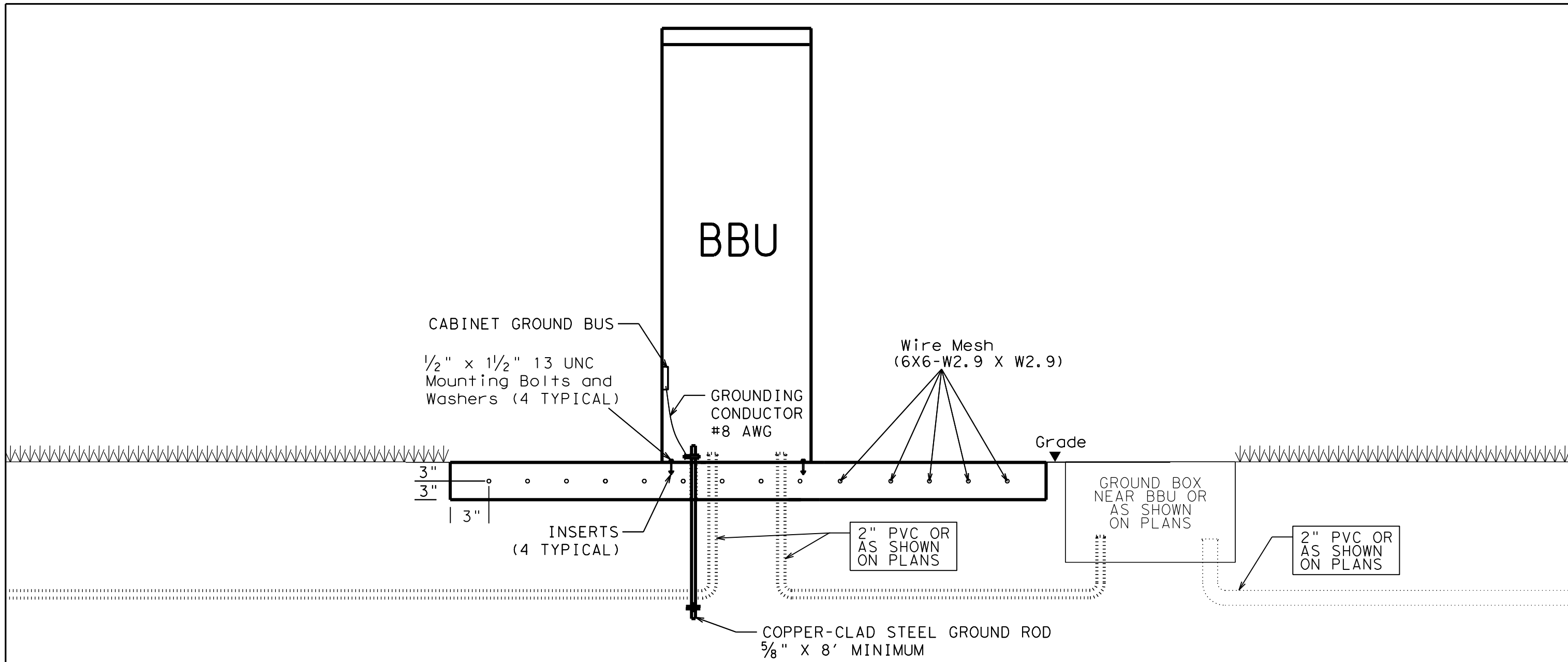

**NOTES:**

1. INSTALL A 5' X 5' CONCRETE PAD AT THE LOCATION DIRECTED BY THE ENGINEER. THE PAD MAY BE CAST-IN-PLACE OR PRE-CAST AS APPROVED BY THE ENGINEER.
2. PROVIDE WELDED WIRE MESH 6X6-W2.9 X W2.9 FOR REINFORCEMENT. PROVIDE JOINTS AND SPLICES IN THE MESH WITH A MINIMUM 6-INCH OVERLAP. PROVIDE A MINIMUM 3 INCH COVER BETWEEN WIRE MESH AND EDGE OF CONCRETE PAD.
3. PROVIDE CLASS B CONCRETE MINIMUM FOR THE CONCRETE PAD IN ACCORDANCE WITH ITEM 421. CONSTRUCT THE CONCRETE PAD IN ACCORDANCE WITH ITEM 531, EXCEPT FOR PAYMENT.
4. INSTALL THE BACK OF BBU CABINET 10" FROM THE EDGE OF CONCRETE PAD AND CENTER THE CABINET ON THE PAD FROM SIDE TO SIDE.
5. SUPPLY FOUR 1/2" X 1/2" 13 UNC STAINLESS STEEL INSERTS FOR ATTACHMENT OF THE BBU CABINET TO THE CONCRETE PAD. INSERTS MUST WITHSTAND A MINIMUM TORQUE OF 50 FT-LB AND A MINIMUM STRAIGHT PULL OUT STRENGTH OF 750 LBS.
6. BOND A #8 AWG COPPER GROUND WIRE AND AN 8 FT GROUND ROD TO THE REINFORCING MESH WITH A SUITABLE UL LISTED CLAMP, AND TERMINATE THE GROUND WIRE TO THE CABINET GROUNDING BUS.
7. INSTALL A PVC SLEEVE TO PREVENT THE GROUND ROD FROM DIRECT EMBEDMENT IN THE CONCRETE PAD.
8. THE ABOVE WORK PERFORMED AND MATERIALS FURNISHED WILL NOT BE PAID FOR DIRECTLY, BUT WILL BE SUBSIDIARY TO PERTINENT ITEMS.

DATE: 2/20/2024 1:05:16 PM  
 U:\TRAFFIC PROJECTS\0918-00-392 Non-Site 9-24\Microstation Files\100 BBU&EVP(2).dgn

<b>Texas Department of Transportation</b> © 2017			
<b>INSTALLATION OF BBU/EVP</b>			
<b>STAND ALONE BBU CABINET (GROUND MOUNT)</b>			
<b>DALLAS DISTRICT STANDARD</b>			
N. T. S.		SHEET 2 OF 3	
FED. RD. DIV. NO.	FEDERAL AID PROJECT NO.	HIGHWAY NO.	
6	(SEE TITLE SHEET)	VA	
STATE	DISTRICT	COUNTY	SHEET NO.
TEXAS	DALLAS	DALLAS, ETC.	100
CONTROL	SECTION	JOB	
0918	00	392	

**SCENARIO A: GROUND MOUNTED CONTROLLER CABINET WITH CABINET MOUNTED BBU**

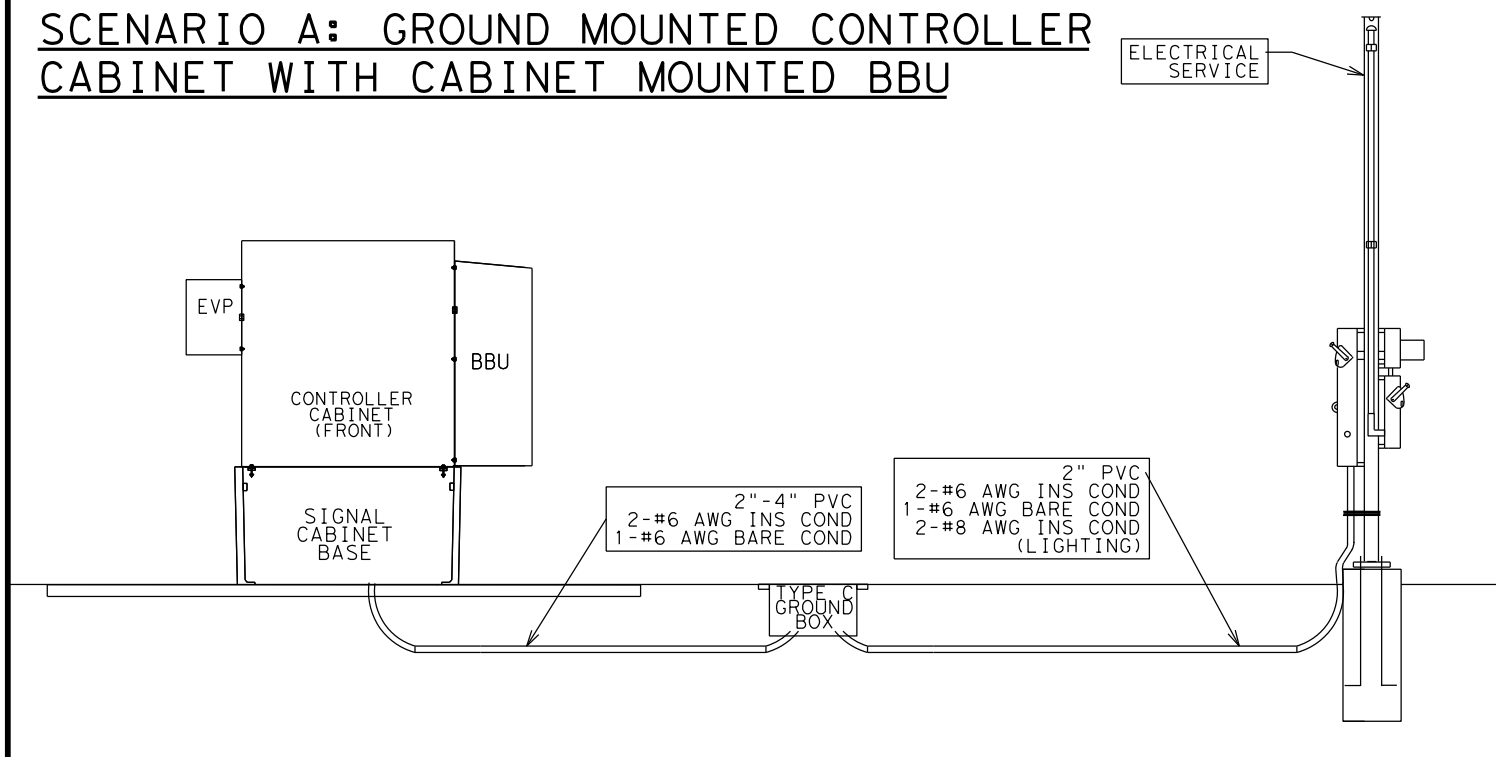

**SCENARIO C: STAND-ALONE BBU FOR POLE MOUNTED CONTROLLER CABINET**

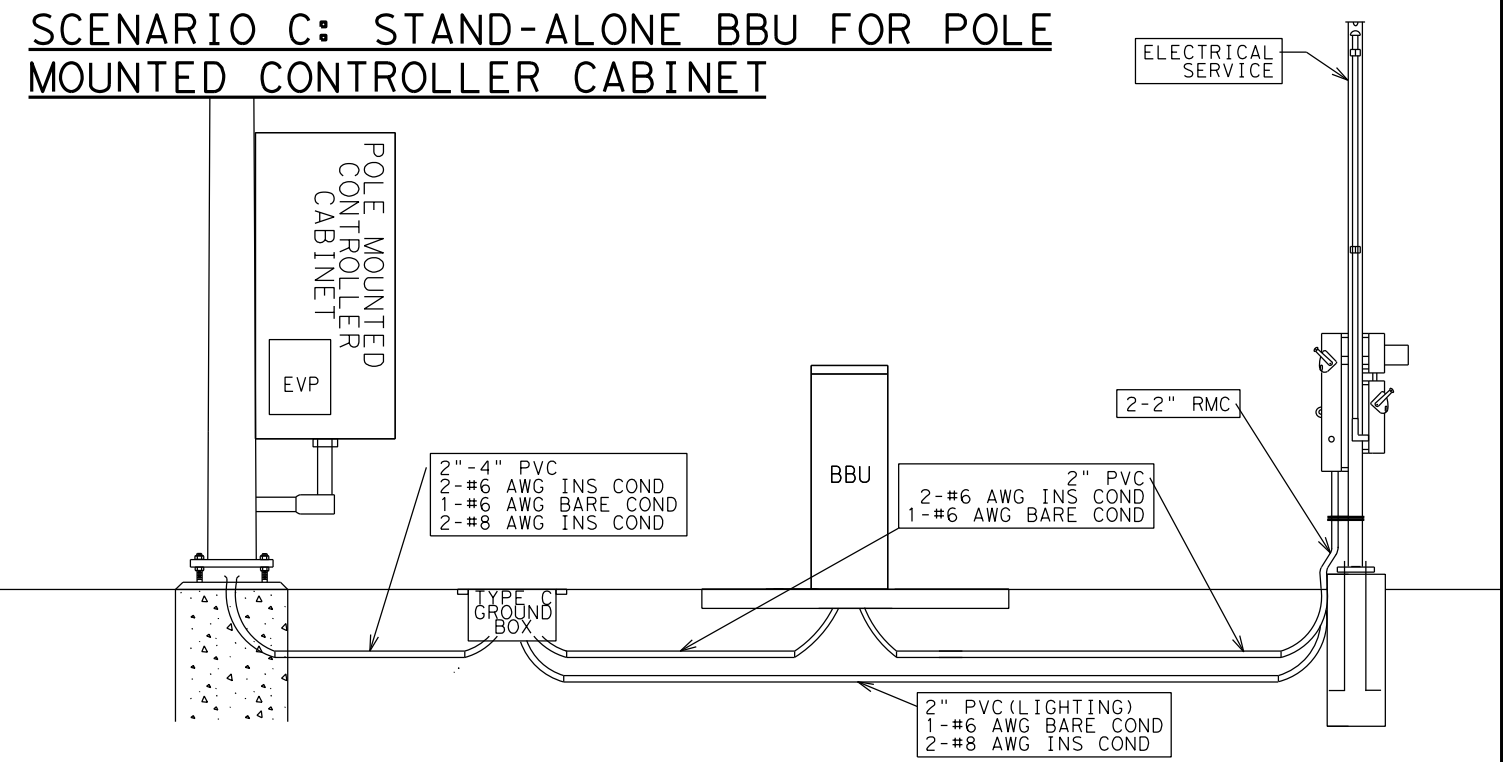

**SCENARIO B: STAND-ALONE BBU FOR GROUND MOUNTED CONTROLLER CABINET**

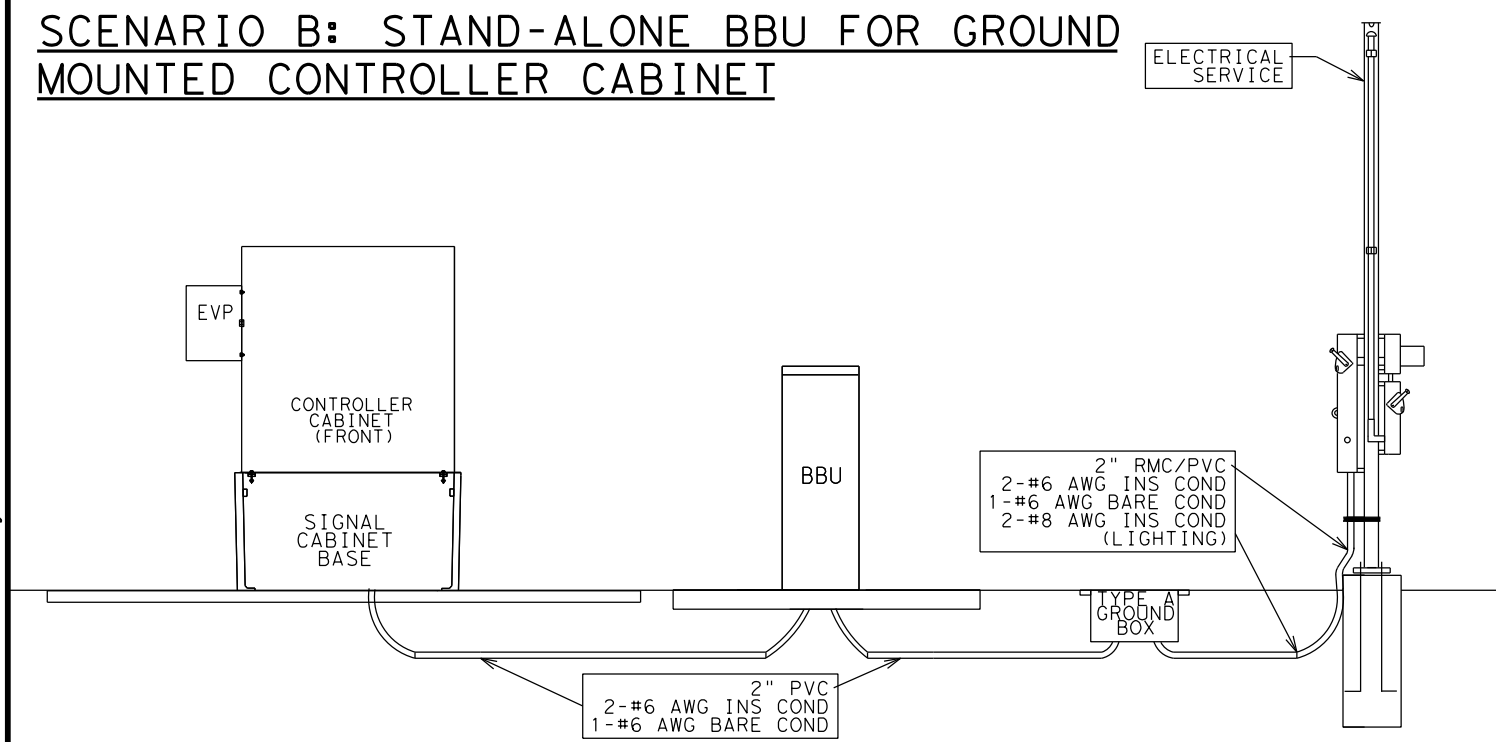

**SCENARIO D: POLE MOUNTED CONTROLLER CABINET WITH CABINET MOUNTED BBU**

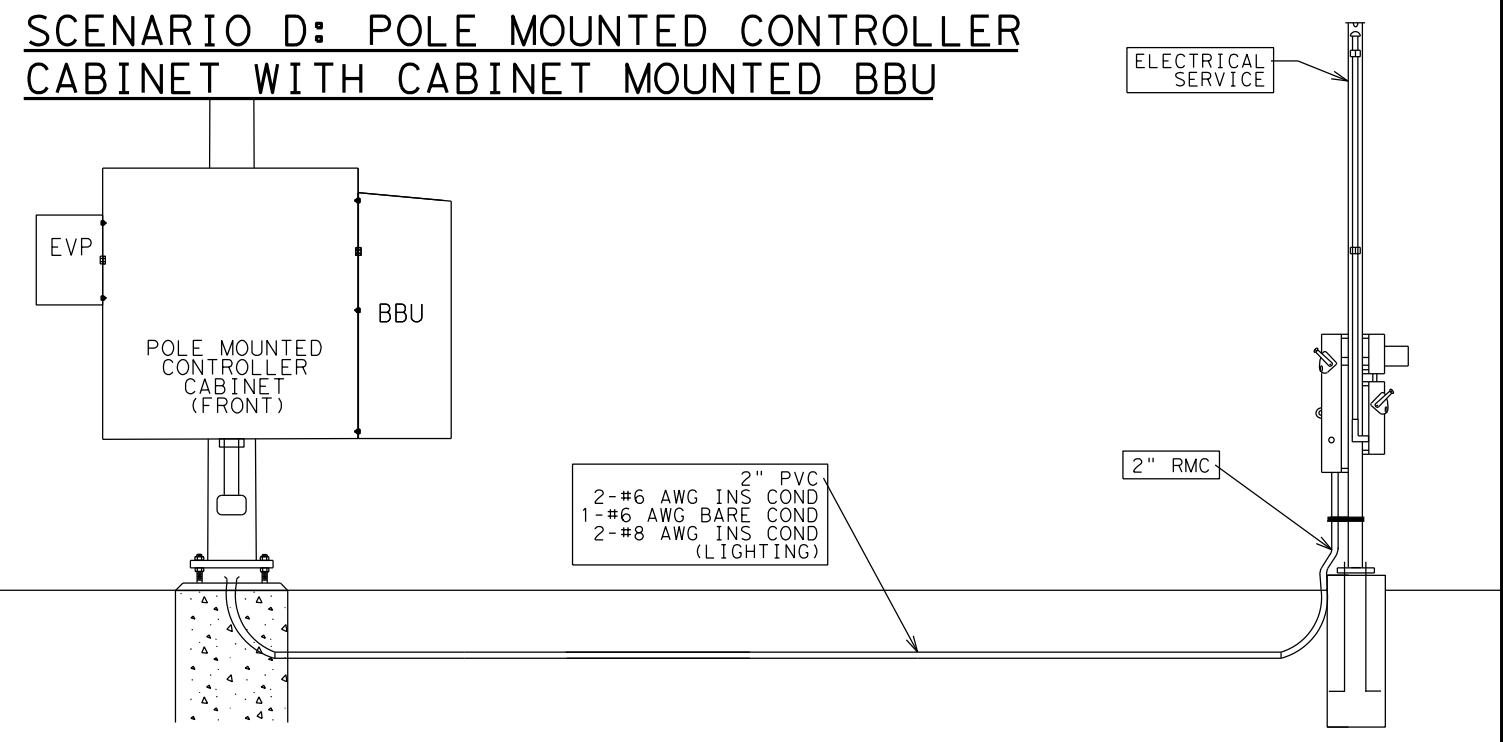

**NOTE:**

ABOVE SCENARIOS ARE TYPICAL BBU/EVP INSTALLATIONS USED IN THE DALLAS DISTRICT. SEE TRAFFIC SIGNAL DESIGN PLANS FOR GROUND BOX, CONDUIT AND CONDUCTOR QUANTITIES AND SIZES SPECIFIC TO EACH INTERSECTION.

DATE: 2/20/2024 1:31:08 PM  
U:\TRAFFIC PROJECTS\0918-00-392 Non-Site 9-24\Microstation Files\101 BBU&EVP (3).dgn



**INSTALLATION OF BBU/EVP  
INSTALLATION SCENARIOS  
DALLAS DISTRICT STANDARD**

N. T. S.		SHEET 3 OF 3	
FED. RD. DIV. NO.	FEDERAL AID PROJECT NO.		HIGHWAY NO.
6	(SEE TITLE SHEET)		VA
STATE	DISTRICT	COUNTY	SHEET NO.
TEXAS	DALLAS	DALLAS, ETC.	101
CONTROL	SECTION	JOB	
0918	00	392	

**PART 1 - GENERAL**

**1.01 DESCRIPTION**

This project includes construction work within the Right-of-Way and/or properties of the Railroad Company and adjacent to its tracks, wire lines and other facilities. These sheets describe the minimum special requirements for coordination with the Railroad when working upon, over or under Railroad Right-of-Way or when impacting current or future Railroad operations. Coordinate with the Railroad while performing the work outlined herein, and afford the same cooperation with the Railroad as with TxDOT. Complete all submittals and work in accordance with TxDOT Standard Specifications, Railroad Guidelines and AREMA recommendations as modified by these minimum special requirements or as directed in writing by the Railroad Designated Representative.

For purposes of this project, the Railroad Designated Representative is the person or persons designated by the Railroad Manager of Industry and Public Projects to handle specific tasks related to the project.

**1.02 REQUEST FOR INFORMATION / CLARIFICATION**

Submit Requests for Information ("RFI") involving work within any Railroad Right-Of-Way to the TxDOT Engineer. The TxDOT Engineer will submit the RFI to the Railroad Designated Representative for review and approval for RFI's corresponding to work within Railroad Right-Of-Way. Allow six (6) weeks total time for review and approval, which includes four (4) weeks for review and approval by the Railroad.

**1.03 PLANS / SPECIFICATIONS**

TxDOT has received written Railroad approval of the plans and specifications for this project. Any revisions or changes in the plans after award of the Contract must have the approval of TxDOT and the Railroad.

**PART 2 - UTILITIES AND FIBER OPTIC**

Construct all utility installations in accordance with current AREMA recommendations, Railroad, TxDOT and owning utility specifications and requirements. Railroad general guidelines can be found on the Railroad website or by contacting the Railroad Designated Representative.

**PART 3 - CONSTRUCTION**

**3.01 GENERAL**

- A. Perform all work in compliance with all applicable Railroad, Federal Railroad Administration (FRA), and TxDOT rules and regulations. Arrange and conduct work in a manner that does not endanger or interfere with the safe operation of the tracks and property of the Railroad and the traffic moving on such tracks, or the wires, signals and other property of the Railroad, its tenants or licensees, at or in the vicinity of the Work. The safe operation of Railroad train movements takes precedence over any work to be performed by the Contractor. The Contractor is responsible for train delay cost and lost revenue claims due to any delays or interruption of train operations resulting from Contractor's construction or other activities.
- B. Construction activities within 12 feet of the operational tracks will only be allowed if absolutely necessary and the Railroad's Designated Representative grants approval. Construction activities within 12 feet of the operational track(s) preferably allow the tracks to stay operational. In such cases, coordination and approval by the Railroad Track Manager is required with regard to schedule, flagging, and slow orders. See Sections 3.07 and 3.08 for additional information.
- C. Provide track protection for all work equipment (including rubber tired equipment) operating within 25 feet from nearest rail. When not in use, keep Contractor machinery and materials at least 50 feet from the Railroad's nearest track.
- D. Vehicular crossings of railroad track are allowed only at existing crossings, or haul road crossings developed with Railroad approval.
- E. The Contractor is also advised that new railroad facilities within the project may be built by the Railroad. If applicable, these facilities are delineated in the plans. Be aware of the limits of responsibilities and coordinate efforts with the Railroad and TxDOT.
- F. Railroad requirements do not allow work within 50 feet of track centers when a train passes the work site and all personnel must clear the area within 50 feet of the track centerline and secure all equipment. Additional allowances may be pursued as outlined in 3.02 and 3.03.
- G. All permanent clearances shall be verified before project closing.

**3.02 RAILROAD OPERATIONS**

- A. Trains and/or equipment are expected on any track, at any time, in either direction. Become familiar with the train schedules in this location and structure bid assuming intermittent track windows in this period, as defined in Paragraph B that follows.
- B. All railroad tracks within and adjacent to the Contract Site are active, and rail traffic over these facilities shall be maintained throughout the Project. Activities may include both through moves and switching moves to local customers. Railroad traffic and operations will occur continuously throughout the day and night on these tracks and shall be maintained at all times as defined herein. Coordinate and schedule the work so that construction activities do not interfere with railroad operations.
- C. Coordinate work windows with TxDOT and the Railroad's Designated Representative. Types of work windows include Conditional Work Windows and Absolute Work Windows, as defined below:
  - 1. Conditional Work Window: A Conditional Work Window is a period of time that railroad operations have priority over construction activities. When construction activities may occur on and/or adjacent to the railroad tracks within 25 feet of the nearest track, a Railroad flag person will be required. At the direction of the Railroad flag person, upon approach of a train, and when trains are present on the tracks, the tracks must be cleared (i.e., no construction equipment, materials or personnel within 25 feet, or as directed by the Railroad Designated Representative, from the tracks). Conditional Work Windows are available for the Project.
  - 2. Absolute Work Window: An Absolute Work Window is a period of time that construction activities are given priority over railroad operations. During this time frame, the designated railroad track(s) will be inactive for train movements and may be fouled by the Contractor. At the end of an Absolute Work Window, the railroad tracks and/or signals must be completely operational for train operations and all Railroad, Public Utilities Commission (PUC) and FRA requirements, codes and regulations for operational tracks must be satisfied. In the situation where the operating tracks and/or signals have been affected, the Railroad will perform inspections of the work prior to placing that track back into service. Railroad flag persons will be required for construction activities requiring an Absolute Work Window. Absolute Work Windows will not generally be granted. Any request will require a detailed explanation for Railroad review.

**3.03 RIGHT OF ENTRY, ADVANCE NOTICE AND WORK STOPPAGES**

- A. Do not perform any work within Railroad Right-of-Way without a valid executed Right of Entry Agreement if required on this project.
- B. Give advance notice to the Railroad as required in the "Contractor's Right of Entry Agreement" before commencing work in connection with construction upon or over Railroad Right-of-Way and observe the Railroad's rules and regulations with respect thereto.
- C. Perform all work upon Railroad Right-of-Way in a manner to avoid interference with or endanger the operations of the Railroad. Whenever work may affect the operations or safety of trains, submit the work method to the Railroad Designated Representative for approval. Approval does not relieve the Contractor from liability. Do not commence any work which requires flagging service or inspection service until the flagging protection required by the Railroad is available at the job site. See Section 3.15 for railroad flagging requirements.
- D. Make requests in writing for both Absolute and Conditional Work Windows, at least 30 days in advance of any work. Include in the written request:
  - 1. Exactly what the work entails.
  - 2. The days and hours that work will be performed.
  - 3. The exact location of work, and proximity to the tracks.
  - 4. The type of window requested and the amount of time requested.
  - 5. The designated contact person.

Provide a written confirmation notice to the Railroad at least 48 hours before commencing work in connection with approved work windows when work is within 25 feet of nearest rail. Perform all work in accordance with previously approved work plans.
- E. Make provisions to protect operations and property of the Railroad should a condition arising from, or in connection with the work, require immediate and unusual action. If in the judgment of the Railroad Designated Representative such provisions are insufficient, the Railroad Designated Representative may require or provide such provisions as deemed necessary. In any event, such provisions shall be at the Contractor's expense and without cost to the Railroad or TxDOT. The Railroad or TxDOT shall have the right to order the Contractor to temporarily cease operations in the event of an emergency or, if in the opinion of the Railroad Designated Representative, the Contractor's operations could endanger railroad operations. In the event of such an order, immediately notify TxDOT of the order.

**3.04 INSURANCE**

Do not begin work upon or over Railroad Right-of-Way until furnishing the Railroad with the insurance policies, binders, certificates and endorsements required by the "Contractor's Right-of-Entry Agreement", and until the Railroad Designated Representative has advised TxDOT that such insurance is in accordance with the Agreement.

**3.05 RAILROAD SAFETY ORIENTATION**

- A. Complete the Railroad course "Orientation for Contractor's Safety", and maintain current registration prior to working on Railroad property. This orientation is available at [www.contractororientation.com](http://www.contractororientation.com). This course is required to be completed annually by Contractor and Subcontractor personnel working on site.

"KCS/TEXMEX will not accept on-track safety training certificates from other railroads. Contractor's employees entering the KCS railroad shall hold current certificates at all times. The training can be had by contacting Larry Slater of TrackSense Inc. at 330-847-8661 or by email at [lslater@neo.rr.com](mailto:lslater@neo.rr.com)."

- B. Know and follow the "Contractor's Right of Entry Agreement" EXHIBIT D, MINIMUM SAFETY REQUIREMENTS regarding clothing, personal protective equipment, and general safety requirements.

**3.06 COOPERATION**

The Railroad will cooperate with Contractor so that work may be conducted in an efficient manner, and will cooperate with Contractor in enabling use of Railroad Right-of-Way in performing the work.

**3.07 MINIMUM CONSTRUCTION CLEARANCES FOR FALSEWORK AND OTHER TEMPORARY STRUCTURES**

Abide by the following minimum temporary clearances during the course of construction:  
 A. 15' - 0" (BNSF), 14'-0" (KCS), and 12'-0" (UPRR) horizontal from centerline of track  
 B. 22' (KCS) and 21' - 6" (UPRR & BNSF) vertically above top of rail.

For construction clearance less than listed above, obtain local Railroad Operating Unit review and approval.

**3.08 APPROVAL OF REDUCED CLEARANCES**

- A. Maintain minimum track clearances during construction as specified in Section 3.07.
- B. Submit any proposed infringement on the specified minimum clearances to the Railroad Designated Representative through TxDOT at least 30 days in advance of the work. Do not proceed with such infringement without written approval by the Railroad Designated Representative.
- C. Do not commence work involving an approved infringement without receiving written assurance from the Railroad Designated Representative that arrangements have been made for any necessary flagging service.

 Texas Department of Transportation				Traffic Operations Division	
<b>RAILROAD REQUIREMENTS FOR NON-BRIDGE CONSTRUCTION PROJECTS</b>					
FILE:	DN: TxDOT	CK: TxDOT	DW: TxDOT	CR: TxDOT	
© TxDOT October 2014	CONT	SECT	JOB	HIGHWAY	
REVISIONS	091800		392	VA	
	DIST	COUNTY		SHEET NO.	
	DAL	DALLAS, ETC.		102	

DATE: 2/20/2024 1:32:27 PM  
 U:\TRAFFIC PROJECTS\0918-00-392 Non-Site 9-24\Microstation Files\102-103 RAILROAD REQUIREMENTS FOR NON-BRIDGE CONSTRUCTION PROJECTS.dgn

DATE: 2/20/2024 1:32:55 PM  
U:\TRAFFIC PROJECTS\0918-00-392 Non-Site 9-24\Microstation Files\102-103 RAILROAD REQUIREMENTS FOR NON-BRIDGE CONSTRUCTION PROJECTS.dgn

**3.09 MAINTENANCE OF RAILROAD FACILITIES**

- A. Maintain all ditches and drainage structures free of silt or other obstructions resulting from Contractor's operations. Repair eroded areas and any other damage within Railroad Right-of Way and repair any other damage to the property of the Railroad, or its tenants.
- B. Perform all such maintenance and repair of damages due to the Contractors's operations at Contractor's expense.
- C. Submit a proposed method of erosion control for review by the Railroad prior to beginning any grading on the Project Site. Comply with all applicable local, state and federal regulations when developing and implementing such erosion control.

**3.10 SITE INSPECTIONS BY RAILROAD'S DESIGNATED REPRESENTATIVE**

- A. In addition to the office reviews of construction submittals, site inspections may be performed by the Railroad Designated Representative at significant points during construction, including the following if applicable:
  - 1. Pre-construction meetings.
  - 2. Pile driving/drilling of caissons or drilled shafts.
  - 3. Reinforcement and concrete placement for railroad bridge substructure and/or superstructure.
  - 4. Erection of precast concrete or steel bridge superstructure.
  - 5. Placement of waterproofing (prior to placing ballast on bridge deck).
  - 6. Completion of the bridge structure.
- B. Site inspection is not limited to the milestone events listed above. Site visits to check progress of the work may be performed at any time throughout the construction as deemed necessary by the Railroad.
- C. Provide a detailed construction schedule, including the proposed temporary horizontal and vertical clearances and construction sequence for all work to TxDOT for submittal to the Railroad Designated Representative for review prior to commencement of work. Include the anticipated dates when the above listed events will occur. Update this schedule for the above listed events as necessary and each month at a minimum to allow the Railroad to schedule site inspections.

**3.11 RAILROAD REPRESENTATIVES**

Railroad representatives, conductors, flag person or watch person will be provided by the Railroad at expense of TxDOT to protect Railroad facilities, property and movements of its trains or engines. In general, the Railroad will furnish such personnel or other protective services as follows:

- A. When any part of any equipment is standing or being operated within 25 feet, measured horizontally, from nearest rail of any track on which trains may operate, or when any object is off the ground and any dimension thereof could extend inside the 25 foot limit, or when any erection or construction activities are in progress within such limits, regardless of elevation above or below track.
- B. For any excavation below elevation of track subgrade if, in the opinion of the Railroad Designated Representative, track or other Railroad facilities may be subject to settlement or movement.
- C. During any clearing, grubbing, excavation or grading in proximity to Railroad facilities, which, in the opinion of the Railroad Designated Representative, may endanger Railroad facilities or operations.
- D. During any Contractor's operations when, in the opinion of the Railroad Designated Representative, Railroad facilities, including, but not limited to, tracks, buildings, signals, wire lines, or pipe lines, may be endangered.
- E. Arrange with the Railroad Designated Representative to provide the adequate number of flag persons to accomplish the work.

**3.12 COMMUNICATIONS AND SIGNAL LINES**

If required, the Railroad will rearrange its communications and signal lines, its grade crossing warning devices, train signals and tracks, and facilities that are in use and maintained by the Railroad's forces in connection with its operation at expense of TxDOT. This work by the Railroad will be done by its own forces and it is not a part of the Work under this Contract.

**3.13 TRAFFIC CONTROL**

Coordinate any operations that control traffic across or around Railroad facilities with the Railroad Designated Representative.

**3.14 CONSTRUCTION EXCAVATIONS AND BORING ACTIVITIES UNDER TRACK**

- A. Take special precaution and care in connection with excavating and shoring. Excavations for construction of footings, piers, columns, walls or other facilities that require shoring shall comply with requirements of TxDOT, OSHA, AREMA and Railroad "Guidelines for Temporary Shoring".
- B. The project plans indicate whether there are fiber optic lines or other such telecommunications systems that require consideration. Regardless, contact the necessary call center to determine if such cable systems are present:

UPRR 1-800-336-9193  
7:00 AM to 9:00 PM CST Monday-Friday except holidays,  
staffed 24 hrs/day for emergencies  
48 hrs notice required

BNSF 1-800-533-2891  
24 hour number  
5 working days notice required

KCS 1-800-344-8377  
Texas One Call, a 24 hour number  
48 hrs notice required, excluding weekends and holidays

If a telecommunications system is buried anywhere on or near Railroad property, coordinate with TxDOT, the Railroad and the Telecommunication Company(ies) to arrange for relocation or protective measures prior to beginning work on or near Railroad property. Refer to the project General Notes for additional information.

- C. Projects involving a boring or jack and bore operation under track such as drainage pipes or culverts and utilities require an installation plan reviewed and approved by the Railroad and TxDOT prior to proceeding with such construction. A railroad inspector and contractor-assisted monitoring of ground and track movement is required to maintain safe passage of rail traffic. Stop installation and do not allow passage of trains if movements in excess of 1/4" vertical or horizontal is detected in the tracks. Immediately repair the damage to the satisfaction of TxDOT and the Railroad before proceeding.

**3.15 RAILROAD FLAGGING**

Per the RIGHT OF ENTRY agreement for flagging, notify the Railroad Representative at least 10 working days in advance of Contractor work and at least 30 working days in advance of any Contractor work in which any person or equipment will be within 25 feet of nearest rail.

**3.16 CLEANING OF RIGHT-OF-WAY**

When work is complete, remove all tools, implements, and other materials brought into Railroad Right-of-Way and leave the Right-of-Way in a clean and presentable condition to the satisfaction of TxDOT and the Railroad.

Texas Department of Transportation				Traffic Operations Division	
RAILROAD REQUIREMENTS FOR NON-BRIDGE CONSTRUCTION PROJECTS					
FILE:	DN: TxDOT	CK: TxDOT	DW: TxDOT	CR: TxDOT	
© TxDOT October 2014	CONT	SECT	JOB	HIGHWAY	
REVISIONS	091800	392	VA		
DIST	COUNTY			SHEET NO.	
DAL	DALLAS, ETC.			103	

DATE: 2/20/2024 4:23:32 PM  
 U:\TRAFFIC PROJECTS\0918-00-392 Non-Site 9-24\Microstation Files\104 RAILROAD SCOPE OF WORK.dgn  
 DISCLAIMER: The use of this standard is governed by the "Texas Engineering Practice Act". No warranty of any kind is made by TxDOT for any purpose whatsoever. TxDOT assumes no responsibility for the conversion of this standard to other formats or for incorrect results or damages resulting from its use.

**I. WORK AT CROSSING LOCATIONS (AT GRADE, HIGHWAY OVERPASS, HIGHWAY UNDERPASS, PEDESTRIAN, OR CLOSED/ABANDONED)**

DOT #: \_\_\_\_\_  
 Crossing Type: \*\* \_\_\_\_\_  
 RR Company Owning Track at Crossing: \_\_\_\_\_  
 Operating RR Company at Track: \_\_\_\_\_  
 RR MP: \_\_\_\_\_  
 RR Subdivision: \_\_\_\_\_  
 City: \_\_\_\_\_  
 County: \_\_\_\_\_  
 CSJ at this Crossing: \_\_\_\_\_  
 Highway/Roadway name crossing the railroad: \_\_\_\_\_  
 # of regularly scheduled trains per day at this crossing: \_\_\_\_\_  
 # of switching movements per day at this crossing: \_\_\_\_\_  
 % of estimated contract cost of work within railroad ROW: \_\_\_\_\_

Scope of Work at this Crossing to Be Performed by State Contractor:  
 \_\_\_\_\_  
 \_\_\_\_\_  
 \_\_\_\_\_

Scope of Work at this Crossing to Be Performed by Railroad Company:  
 \_\_\_\_\_  
 \_\_\_\_\_  
 \_\_\_\_\_

\*\* Choose: Highway Overpass, Highway Underpass, At Grade, Pedestrian, or Closed/Abandoned

**II. OTHER PROJECT WORK WITHIN RAILROAD RIGHTS-OF-WAY (ROW)**

\_\_\_\_\_  
 \_\_\_\_\_  
 \_\_\_\_\_

**III. FLAGGING**

# of Days of Railroad Flagging Expected: \_\_\_\_\_  
 On this project, night or weekend flagging is:  
 Expected  
 Not Expected  
 Flagging services will be provided by:  
 Railroad Company: TxDOT will pay flagging invoices  
 Outside Party: Contractor will pay flagging invoices, to be reimbursed by TxDOT

Contractor must incorporate flaggers into anticipated construction schedule. The railroad requires a 30 day notice if their flaggers are to be utilized. If contractor falls behind schedule due to their own negligence and is not ready for scheduled flaggers, any flagging charges will be paid by Contractor.

Contact Information for Flagging:

\_\_\_\_\_  
 \_\_\_\_\_  
 \_\_\_\_\_  
 \_\_\_\_\_

**IV. CONSTRUCTION WORK TO BE PERFORMED BY THE RAILROAD**

On this project, construction work to be performed by a railroad company is:  
 Required  
 Not Required

Coordinate with TxDOT for any work to be performed by the railroad company. TxDOT must issue a work order for any work done by the railroad company prior to the work being performed.

**V. RAILROAD INSURANCE REQUIREMENTS**

Contractor shall provide the proper insurance as shown in the table below.

Insurance policies must be issued for and on behalf of the Railroad. Where more than one Railroad Company is operating on the same right of way or where several railroad companies are involved and operate on their own separate rights of way, provide separate insurance policies in the name of each Railroad Company.

No direct compensation will be made to the contractor for providing the insurance coverages shown below or any deductibles. These costs are incidental to the various bid items.

Type of Insurance	Amount of Coverage (Minimum)
Workers Compensation	\$500,000 / \$500,000 / \$500,000
Commercial General Liability	\$2,000,000 / \$4,000,000
Business Automobile	\$2,000,000 combined single limit
Railroad Protective Liability	** / **

**VI. CONTRACTOR'S RIGHT-OF-ENTRY (ROE) AGREEMENT**

On this project, an ROE agreement is:  
 Not Required  
 Required: TxDOT to assist in obtaining (see Item 5, Article 8.3)

With the following railroad companies: \_\_\_\_\_

Required: Contractor to obtain (see Item 5, Article 8.4)

With the following railroad companies: \_\_\_\_\_

To view previously approved ROE agreement templates agreed upon between the State and railroad company, see:

<http://www.txdot.gov/inside-txdot/division/traffic/samples.html>

Approved ROE agreement templates are not to be modified by the Contractor.

Contractor shall not operate within railroad rights of way without an executed Construction & Maintenance agreement between the state and the railroad and an executed ROE agreement between the contractor and the railroad if required on project.

**VII. RAILROAD COORDINATION MEETING**

On this project, a Railroad Coordination Meeting is:

Not Required  
 Required

See Item 5, Article 8.1 for more details.

**VIII. SUBCONTRACTORS**

Contractor shall not subcontract work without written consent of TxDOT. Subcontractors are required to maintain the same insurance coverage as required of the Contractor.

**IX. EMERGENCY NOTIFICATION**

**In Case of Railroad Emergency**  
**Call \*\*\*\*\* Railroad Emergency Line**  
**at XXX-XXX-XXXX**  
**Location: DOT \*\*\*\*\***  
**RR Milepost \*\*\*\*\* Subdivision**



**RAILROAD SCOPE OF WORK  
PROJECT SPECIFIC DETAILS**

FILE: RR Scope of Work.dgn	DN: TxDOT	CK: TxDOT	DW: TxDOT	CR: TxDOT
© TxDOT June 2014	CONT	SECT	JOB	HIGHWAY
10/2015	REVISIONS	091800	392	VA
	DIST	COUNTY	SHEET NO.	
	DAL	DALLAS, ETC.	104	



DISCLAIMER: The use of this standard is governed by the "Texas Engineering Practice Act". No warranty of any kind is made by TxDOT for any purpose whatsoever. TxDOT assumes no responsibility for the conversion of this standard to other formats or for incorrect results or damages resulting from its use.

REFLECTOR UNIT SIZES FOR DELINEATORS AND OBJECT MARKERS				DELINEATORS				D & OM DESCRIPTIVE CODES	
DEVICE	SIZE 1	SIZE 2	SIZE 3	SIZE 4	DEVICE	SINGLE	DOUBLE	INSTL DEL ASSM (D-XX)SZ X (XXXX)XXX (XX)	
								NUMBER OF REFLECTORS S = Single D = Double COLOR OF REFLECTORS W = White Y = Yellow R = Red REFLECTOR UNIT SIZE 1 or 2 TYPE OF POST OR DELINEATOR WC = Wing Channel Post YFLX = Yellow Flexible Post WFLX = White Flexible Post BRFL = Barrier Reflector TYPE OF MOUNT GND = Embedded (drivable or set in concrete) CTB = Concrete Barrier Mount GF1 or GF2 = Guard Fence Attachment SRF = Surface Mount DIRECTION If Required BI = Bi-Directional BR = Bi-Directional with red on back	
SHEETING: Yellow, White or Red Type B or C reflective sheeting				SHEETING: Yellow, White or Red Type B or C Reflective Sheeting				INSTL OM ASSM (OM-XX) (XXXX)XXX (XX)	
NOTE: 1. Size 1 and 4 - Direct applied reflective sheeting for use on flexible post (fix). 2. Size 2 and 3 - For use on wing channel (wc) post only. Use approved metal, plastic or fiberglass backplate with 17/64" mounting holes.				POST TYPE: WC, YFLX, WFLX, GND				TYPE OF OBJECT MARKER 1, 2, 3, or 4 NUMBER OF REFLECTORS OR DIRECTION X = 3-Size 2 reflector unit (Type 2 only) Y = 1-Size 3 reflector unit (Type 2 only) Z = 3-Size 1 or 1-Size 4 reflector unit(s) (Type 2 only) L = Left Side (Type 3 Object Marker only) R = Right Side (Type 3 Object Marker only) C = Center (Type 3 Object Marker only) TYPE OF POST WC = Wing Channel Post WFLX = White Flexible Post TWT = Thin Walled Tubing TYPE OF MOUNT GND = Embedded (drivable) SRF = Surface Mount WAS = Wedge Anchor Steel WAP = Wedge Anchor Plastic DIRECTION If Required BI = Bi-Directional	

OBJECT MARKERS									
DEVICE	Type 1 (OM-1)		Type 2 (OM-2)			Type 3 (OM-3)			Type 4 (OM-4)
	OM-1	OM-2X	OM-2Y	OM-2Z	OM-3L	OM-3R	OM-3C	OM-4	
SHEETING: Yellow-Type B <sub>FL</sub> or C <sub>FL</sub> Sheeting		SHEETING: Yellow - Type B or C Sheeting			SHEETING: Alternating acrylic black and retroreflective yellow - Type B <sub>FL</sub> or C <sub>FL</sub> Sheeting			SHEETING: Red -Type B <sub>FL</sub> or C <sub>FL</sub> Sheeting	
POST TYPE: TWT		POST TYPE: WC		POST TYPE: WFLX	POST TYPE: TWT			POST TYPE: TWT	
MOUNT TYPE: WAS, WAP		MOUNT TYPE: GND		MOUNT TYPE: GND, SRF	MOUNT TYPE: WAS, WAP			MOUNT TYPE: WAS, WAP	

DEPARTMENTAL MATERIAL SPECIFICATIONS	
FLEXIBLE DELINEATOR & OBJECT MARKER POSTS (EMBEDDED & SURFACE MOUNT TYPES)	DMS-4400
SIGN FACE MATERIALS	DMS-8300
DELINEATORS, OBJECT MARKERS AND BARRIER REFLECTORS	DMS-8600

BARRIER REFLECTORS (BRF)			CHEVRONS				ONE DIRECTION LARGE ARROW		NOTE: Delineator and object marker substrates and sign substrates shall be 0.080" Aluminum sign blank to conform to ASTM B-209 Alloy 6061-T6 or approved alternative.
DEVICE	GF1	GF2	CTB	W1-8				W1-6	
				SIZE (W x L) 18" x 24" (Conventional) 24" x 30" (Conventional Oversize) 30" x 36" (Expressway) 36" x 48" (Freeway)				SIZE (W x L) 48" x 24" (Conventional) 60" x 30" (Expressway & Freeway)	
1. Barrier reflectors shall meet the requirements of DMS 8600. 2. Approved Barrier Reflectors are listed on the "Barrier Reflectors" Material Producer List at: www.txdot.gov.			MOUNTING HEIGHT 4'-0" or 7'-0"				MOUNTING HEIGHT 7'-0"		
SHEETING: Yellow, White, Red			NOTE: 1. CHEVRON (W1-8) signs and ONE DIRECTION LARGE ARROW (W1-6) Signs shall be installed per Sign Mounting Details (SMD) Standard Sheets and paid under Item 644 (Small Roadside Sign Assemblies). 2. When there is a need to increase conspicuity, the Texas version of the ONE DIRECTION LARGE ARROW sign (W1-9T) may be used instead of the ONE DIRECTION LARGE ARROW (W1-6).						
NOTE: 1. Reflective sheeting shall have a minimum dimension of 3 inches and minimum surface area of 9 square inches.									



### DELINEATOR & OBJECT MARKER MATERIAL DESCRIPTION

#### D & OM(1)-20

FILE: dom1-20.dgn	DN: TxDOT	CK: TxDOT	DW: TxDOT	CR: TxDOT
© TxDOT August 2004	CONT	SECT	JOB	HIGHWAY
REVISIONS	0918	00	392	VA
10-09 3-15	DIST	COUNTY	SHEET NO.	
4-10 7-20	DAL	DALLAS, ETC.	105	

DATE: FILE:

DISCLAIMER: The use of this standard is governed by the "Texas Engineering Practice Act". No warranty of any kind is made by TxDOT for any purpose whatsoever. TxDOT assumes no responsibility for the conversion of this standard to other formats or for incorrect results or damages resulting from its use.

POST TYPE AND SUPPORT FOUNDATION DETAILS				TYPE OF BARRIER MOUNTS	
WING CHANNEL (WC)	FLEXIBLE POSTS (YFLX, WFLX)		WEDGE ANCHOR SYSTEMS		GUARD FENCE ATTACHMENT
GND	GND	SRF	WAS	WAP	GF 1
<p>Ground Line</p> <p>2'-0" Usual</p>	<p>Reflective material</p> <p>Post</p> <p>Stub</p>	<p>Reflective material</p> <p>Post</p> <p>Base</p>	<p>12" Dia.</p> <p>12" 27" 30"</p>	<p>3" (Approx.)</p> <p>15" 17" 20"</p> <p>12" Dia.</p>	<p>Centerline of MBCF rail element</p>
	EMBEDDED		SURFACE MOUNT	STEEL	PLASTIC
<b>NOTES</b> 1. Embedded Wing Channel (WC) post option may be used for Type 2 Object Markers and Delineators only. 2. 1.12 lbs/ft steel per ASTM A 1011 SS Gr. 50, or ASTM A499.	<b>NOTES</b> 1. See "Flexible Delineator and Object Marker Posts" Material Producer List for approved devices. 2. Install per manufacturer's recommendations. 3. Post length may vary to meet field conditions. 4. When using yellow delineators with flexible posts to separate opposing direction of travel, such as centerline or median use, the flexible posts shall be yellow.		<b>NOTE</b> 1. Install per manufacturer's recommendations.		

TYPE OF BARRIER MOUNTS	
GUARD FENCE ATTACHMENT	
GF 1	GF 2
	<p>Attached to post or block</p> <p>2'-6" Min.</p> <p>4" Min.</p> <p>4'-0"</p>

CONCRETE TRAFFIC BARRIER (CTB)	

GENERAL NOTES
1. Place delineators on a section of roadway at a consistent distance from the edge of pavement. 2. Where a restriction prevents consistent placement from the pavement edge, place the affected object markers in line with the innermost edge of the obstruction. 3. When Type 2 object markers and delineators are more than 8'-0" from the edge of the pavement, it may not be possible to maintain a height of approximately 4'-0". If this is the case, place the object marker or delineator as close to the desired height as possible. 4. Install all delineators, object markers and barrier reflectors in accordance with the manufacturer's recommendation. 5. Barrier reflectors should be installed a minimum of 18 inches above the edge of the pavement surface. 6. Diagonal stripes on Type 3 object markers shall slope down toward the intended travel lane.

TYPES 1,3, AND 4 OBJECT MARKERS AND CHEVRONS
<p>Pavement surface</p> <p>Ground Line</p> <p>4'-0"</p>
<b>NOTE</b> Mounting at 4 feet to the bottom of the chevron is permitted for chevrons that will not exceed a height of 6'-6" to the top of the chevron (sizes 24" x 30" and smaller)

CHEVRONS AND ONE DIRECTION LARGE ARROW SIGN
<p>Pavement surface</p> <p>Ground Line</p> <p>7'-0"</p>
<b>NOTE</b> Chevrons 30" x 36" and larger shall be mounted at a height of 7' to the bottom of the chevron. Chevron sign and ONE DIRECTION LARGE ARROW sign (W1-9T) shall be installed per SMD standard sheets and paid under item 644.

DELINEATORS AND TYPE 2 OBJECT MARKERS
<p>Pavement surface</p> <p>Ground Line</p> <p>Approximately 4'-0"</p> <p>2'-0" to 8'-0" or in front of object being marked</p>
<b>NOTE</b> See general notes 1, 2 and 3.

		<b>Traffic Safety Division Standard</b>	
<h2>DELINEATOR &amp; OBJECT MARKER INSTALLATION</h2> <h3>D &amp; OM(2)-20</h3>			
FILE: dom2-20.dgn	DN: TxDOT	CK: TxDOT	DW: TxDOT
© TxDOT August 2004	CONT	SECT	JOB
REVISIONS	0918	00	392
10-09 3-15	DIST	COUNTY	SHEET NO.
4-10 7-20	DAL	DALLAS, ETC.	106

DATE: FILE:

DISCLAIMER: The use of this standard is governed by the "Texas Engineering Practice Act". No warranty of any kind is made by TxDOT for any purpose whatsoever. TxDOT assumes no responsibility for the conversion of this standard to other formats or for incorrect results or damages resulting from its use.

### MINIMUM WARNING DEVICES AT CURVES WITH ADVISORY SPEEDS

Amount by which Advisory Speed is less than Posted Speed	Curve Advisory Speed	
	Turn (30 MPH or less)	Curve (35 MPH or more)
5 MPH & 10 MPH	• RPMs	• RPMs
15 MPH & 20 MPH	• RPMs and One Direction Large Arrow sign	• RPMs and Chevrons; or • RPMs and One Direction Large Arrow sign where geometric conditions or roadside obstacles prevent the installation of chevrons.
25 MPH & more	• RPMs and Chevrons; or • RPMs and One Direction Large Arrow sign where geometric conditions or roadside obstacles prevent the installation of chevrons	• RPMs and Chevrons

### SUGGESTED SPACING FOR DELINEATORS ON HORIZONTAL CURVES

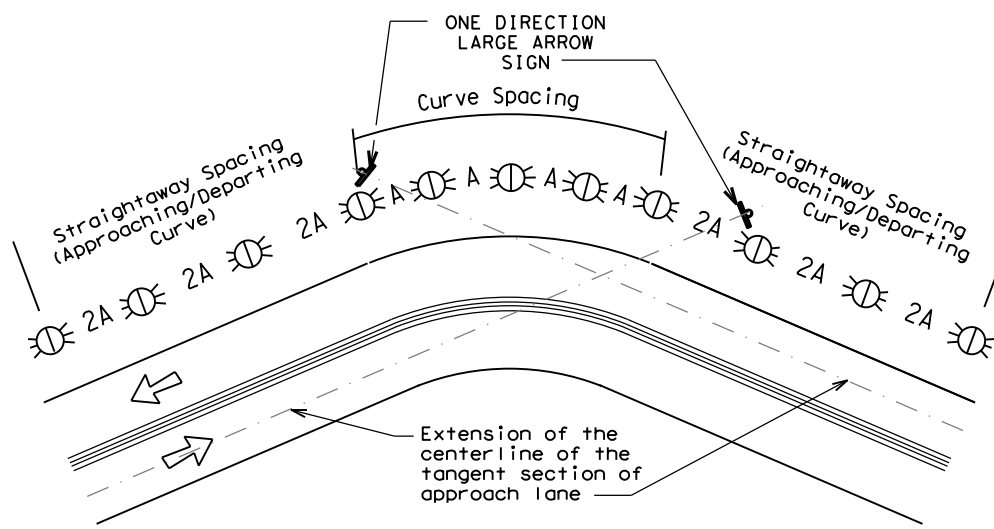

**NOTE**

ONE DIRECTION LARGE ARROW (W1-6) sign should be located at approximately and perpendicular to the extension of the centerline of the tangent section of approach lane.

### SUGGESTED SPACING FOR CHEVRONS ON HORIZONTAL CURVES

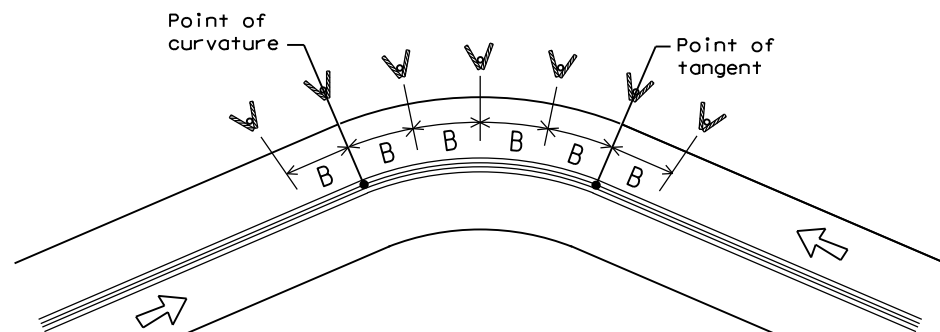

**NOTE**

At least one chevron pair is installed beyond the point of tangent in tangent section.

### DELINEATOR AND CHEVRON SPACING

WHEN DEGREE OF CURVE OR RADIUS IS KNOWN				
Degree of Curve	FEET			
	Radius of Curve	Spacing in Curve	Spacing in Straightaway	Chevron Spacing in Curve
		A	2A	B
1	5730	225	450	—
2	2865	160	320	—
3	1910	130	260	200
4	1433	110	220	160
5	1146	100	200	160
6	955	90	180	160
7	819	85	170	160
8	716	75	150	160
9	637	75	150	120
10	573	70	140	120
11	521	65	130	120
12	478	60	120	120
13	441	60	120	120
14	409	55	110	80
15	382	55	110	80
16	358	55	110	80
19	302	50	100	80
23	249	40	80	80
29	198	35	70	40
38	151	30	60	40
57	101	20	40	40

Curve delineator approach and departure spacing should include 3 delineators spaced at 2A. This spacing should be used during design preparation or when the degree of curve is known.

### DELINEATOR AND CHEVRON SPACING

WHEN DEGREE OF CURVE OR RADIUS IS NOT KNOWN			
Advisory Speed (MPH)	Spacing in Curve	Spacing in Straightaway	Chevron Spacing in Curve
	A	2xA	B
65	130	260	200
60	110	220	160
55	100	200	160
50	85	170	160
45	75	150	120
40	70	140	120
35	60	120	120
30	55	110	80
25	50	100	80
20	40	80	80
15	35	70	40

If the degree of curve is not known, delineator spacing may be determined based on the Advisory Speed of the curve. Use the delineator curve spacing for each Advisory Speed (MPH).

### DELINEATOR AND OBJECT MARKER APPLICATION AND SPACING

CONDITION	REQUIRED TREATMENT	MINIMUM SPACING
Frwy./Exp. Tangent	RPMs	See PM-series and FPM-series standard sheets
Frwy./Exp. Curve	Single delineators on right side	See delineator spacing table
Frwy/Exp. Ramp	Single delineators on at least one side of ramp (should be on outside of curves) (see Detail 3 on D&OM(4))	100 feet on ramp tangents Use delineator spacing table for ramp curves ("straightway spacing" does not apply to ramp curves)
Acceleration/Deceleration Lane	Double delineators (see Detail 3 on D&OM(4))	100 feet (See Detail 3 on D & OM (4))
Truck Escape Ramp	Single red delineators on both sides	50 feet
Bridge Rail (steel or concrete) and Metal Beam Guard Fence	Bi-Directional Delineators when undivided with one lane each direction Single Delineators when multiple lanes each direction	Equal spacing (100' max) but not less than 3 delineators
Concrete Traffic Barrier (CTB) or Steel Traffic Barrier	Barrier reflectors matching the color of the edge line	Equal spacing 100' max
Cable Barrier	Reflectors matching the color of the edge line	Every 5th cable barrier post (up to 100' max)
Guard Rail Terminus/Impact Head	Divided highway - Object marker on approach end Undivided 2-lane highways - Object marker on approach and departure end	Requires reflective sheeting provided by manufacturer per D & OM (VIA) or a Type 3 Object Marker (OM-3) in front of the terminal end See D & OM (5) and D & OM (6)
Bridges with no Approach Rail	Type 3 Object Marker (OM-3) at end of rail and 3 single delineators approaching rail	See D & OM(5)
Reduced Width Approaches to Bridge Rail	Type 2 and Type 3 Object Markers (OM-3) and 3 single delineators approaching bridge	Requires reflective sheeting provided by manufacturer per D & OM (VIA) or a Type 3 Object Marker (OM-3) in front of the terminal end See D & OM (5)
Culverts without MBGF	Type 2 Object Markers	See Detail 2 on D & OM(4)
Crossovers	Double yellow delineators and RPMs	See Detail 1 on D & OM (4)
Pavement Narrowing (lane merge) on Freeways/Expressway	Single delineators adjacent to affected lane for full length of transition	100 feet

**NOTES**

- Unless indicated otherwise, the delineator or barrier reflector color shall conform to the color of the pavement edge line on the side of the road where the delineators or barrier reflectors are placed.
- Barrier reflectors may be used to replace required delineators.
- Single red delineators may be mounted on the back side of delineator posts for wrong way driver applications

LEGEND	
	Bi-directional Delineator
	Delineator
	Sign

Texas Department of Transportation  
Traffic Safety Division Standard

## DELINEATOR & OBJECT MARKER PLACEMENT DETAILS

### D & OM(3)-20

FILE: dom3-20.dgn	DW: TXDOT	CK: TXDOT	OW: TXDOT	CR: TXDOT
© TXDOT August 2004	CONT	SECT	JOB	HIGHWAY
REVISIONS		0918 00	392	VA
3-15 8-15	DIST	COUNTY	SHEET NO.	
8-15 7-20	DAL	DALLAS, ETC.	107	

DATE:  
FILE:

DISCLAIMER: The use of this standard is governed by the "Texas Engineering Practice Act". No warranty of any kind is made by TxDOT for any purpose whatsoever. TxDOT assumes no responsibility for the conversion of this standard to other formats or for incorrect results or damages resulting from its use.

DATE:  
FILE:

**CROSSOVERS**

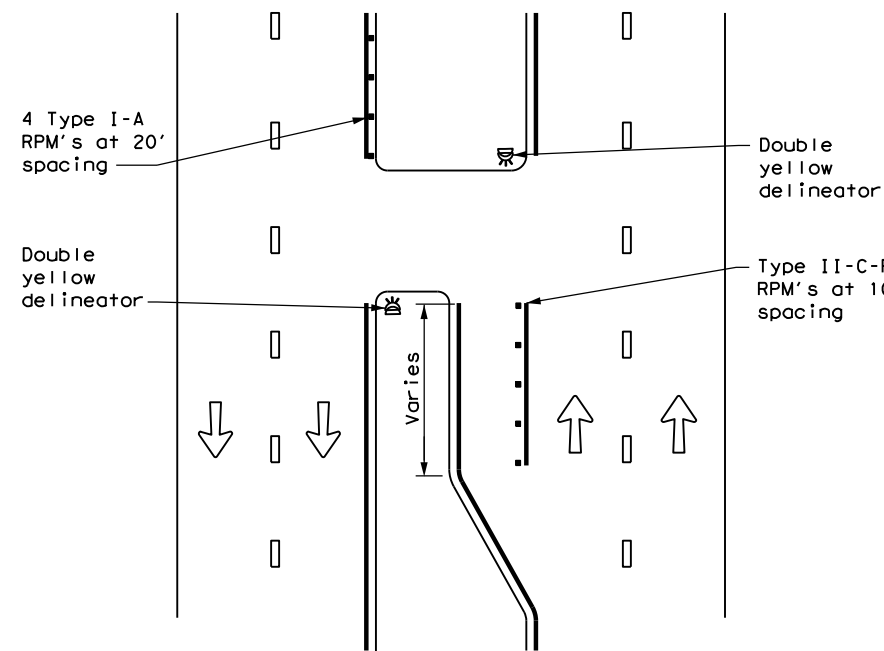

**DETAIL 1**

**FOR CULVERTS WITHOUT MBGF**

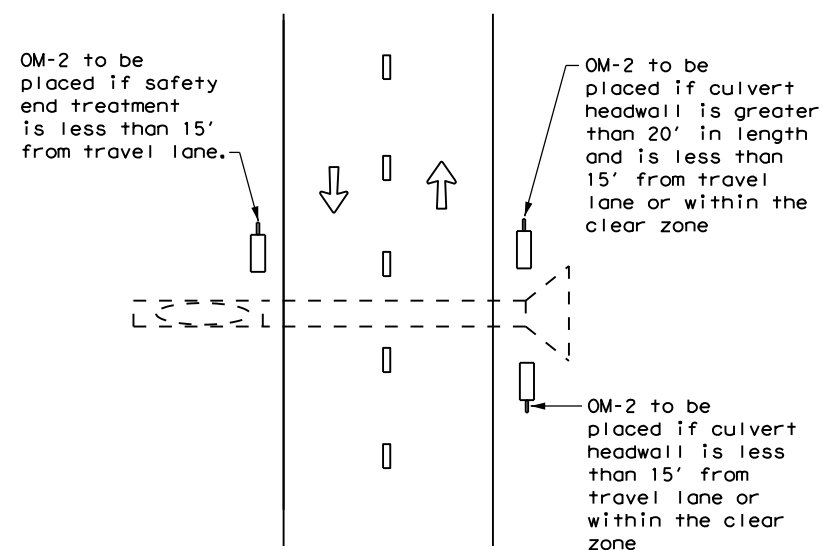

**DETAIL 2**

**FREEWAY DELINEATION FOR RAMPS AND ACCELERATION/DECELERATION LANES**

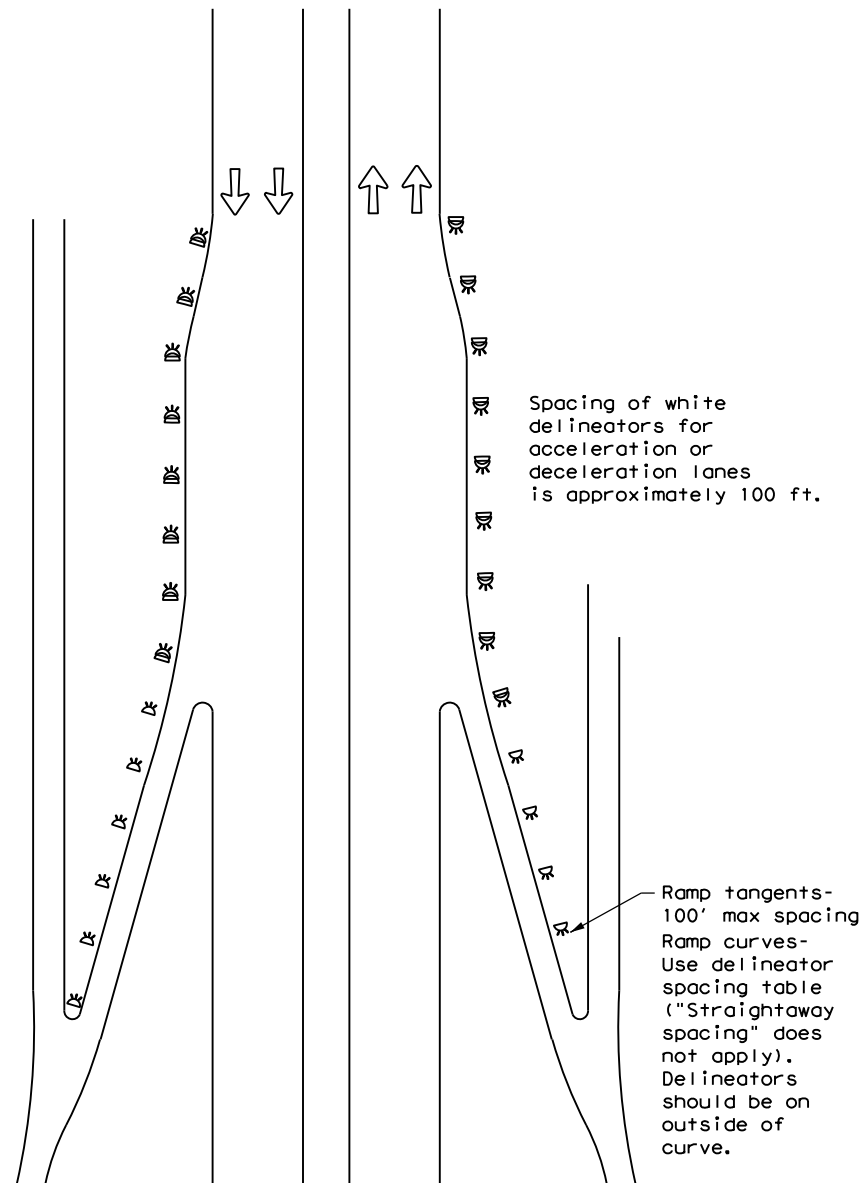

**DETAIL 3**

**TYPICAL APPLICATION OF DEAD END BARRICADE**

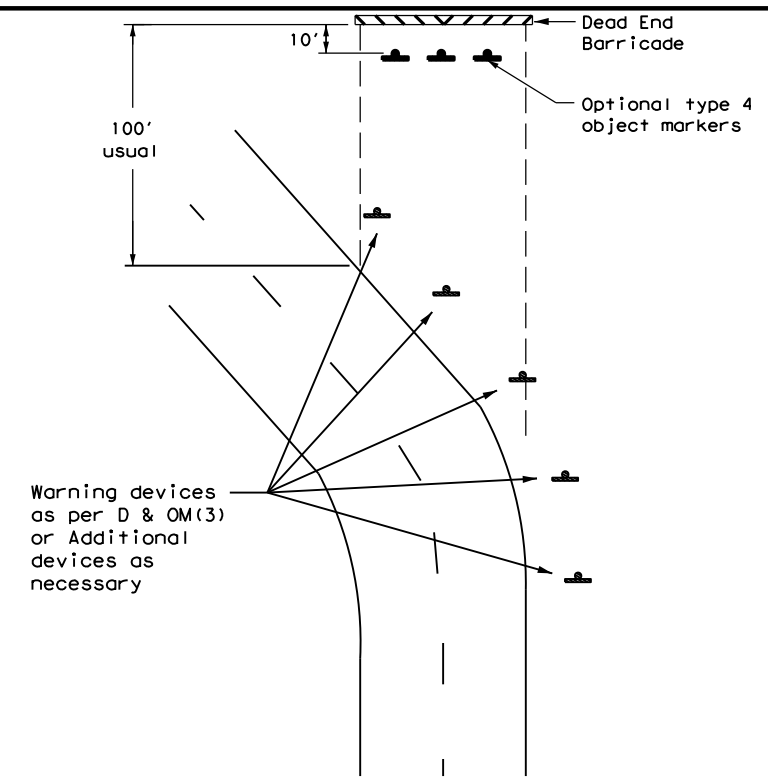

**DETAIL 4**

**TYPICAL DEAD END BARRICADE INSTALLATION**

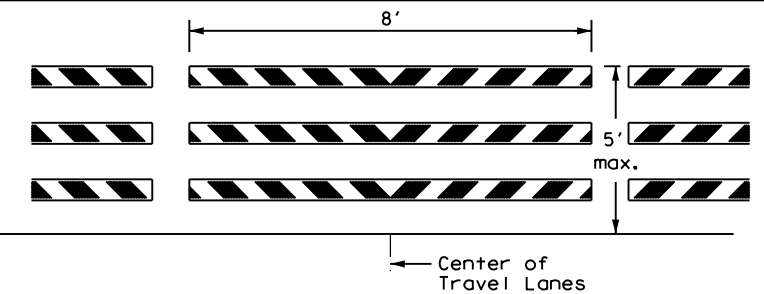

**NOTES**

- Barricade striping shall be red and white reflective sheeting for all permanent road closures.
- Barricade striping is red and white sloping toward the center of the roadway.
- Type 3 Barricade Supports should be anchored to soil or pavement as described in compliant Work Zone Traffic Control Devices List, section D.2.f and D.2.g.

**DETAIL 5**

LEGEND	
	Bidirectional Delineator
	Delineator
	OM-3
	Barricade
	Sign
	OM-2
	Double Delineator



**DELINEATOR & OBJECT MARKER PLACEMENT DETAILS**

**D & OM(4) -20**

FILE: dom4-20.dgn	DN: TXDOT	CK: TXDOT	OW: TXDOT	CR: TXDOT
© TXDOT August 2004	CONT	SECT	JOB	HIGHWAY
REVISIONS	0918	00	392	VA
3-15	DIST	COUNTY	SHEET NO.	
7-20	DAL	DALLAS, ETC.	108	

**TWO-WAY, TWO LANE ROADWAY  
WITH REDUCED WIDTH APPROACH RAIL**

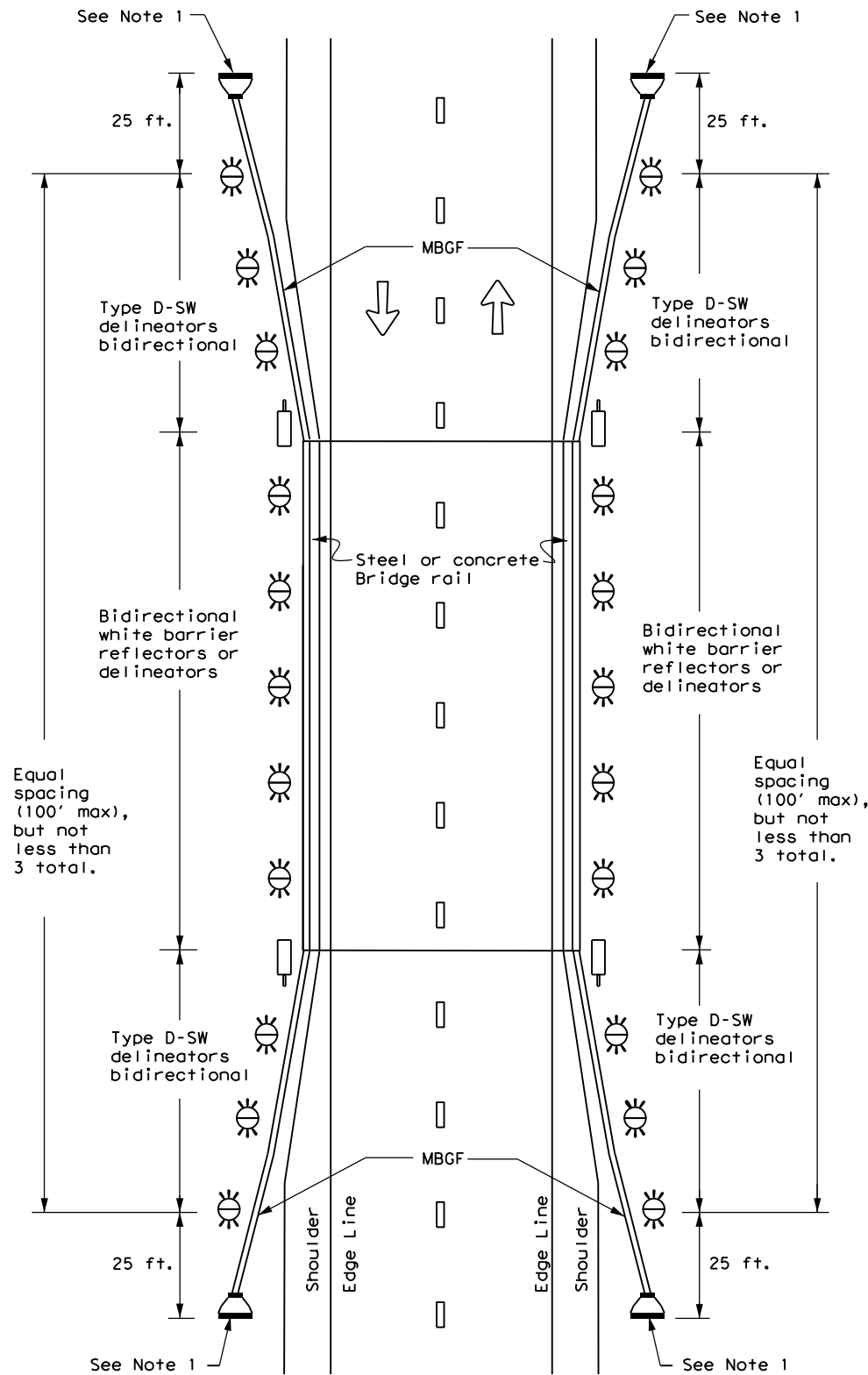

**NOTE:**

1. Terminal ends require reflective sheeting provided by manufacturer per D & OM (VIA) or a Type 3 Object Marker (OM-3) in front of the terminal end.

**TWO-WAY, TWO LANE ROADWAY  
WITH METAL BEAM GUARD FENCE (MBGF)**

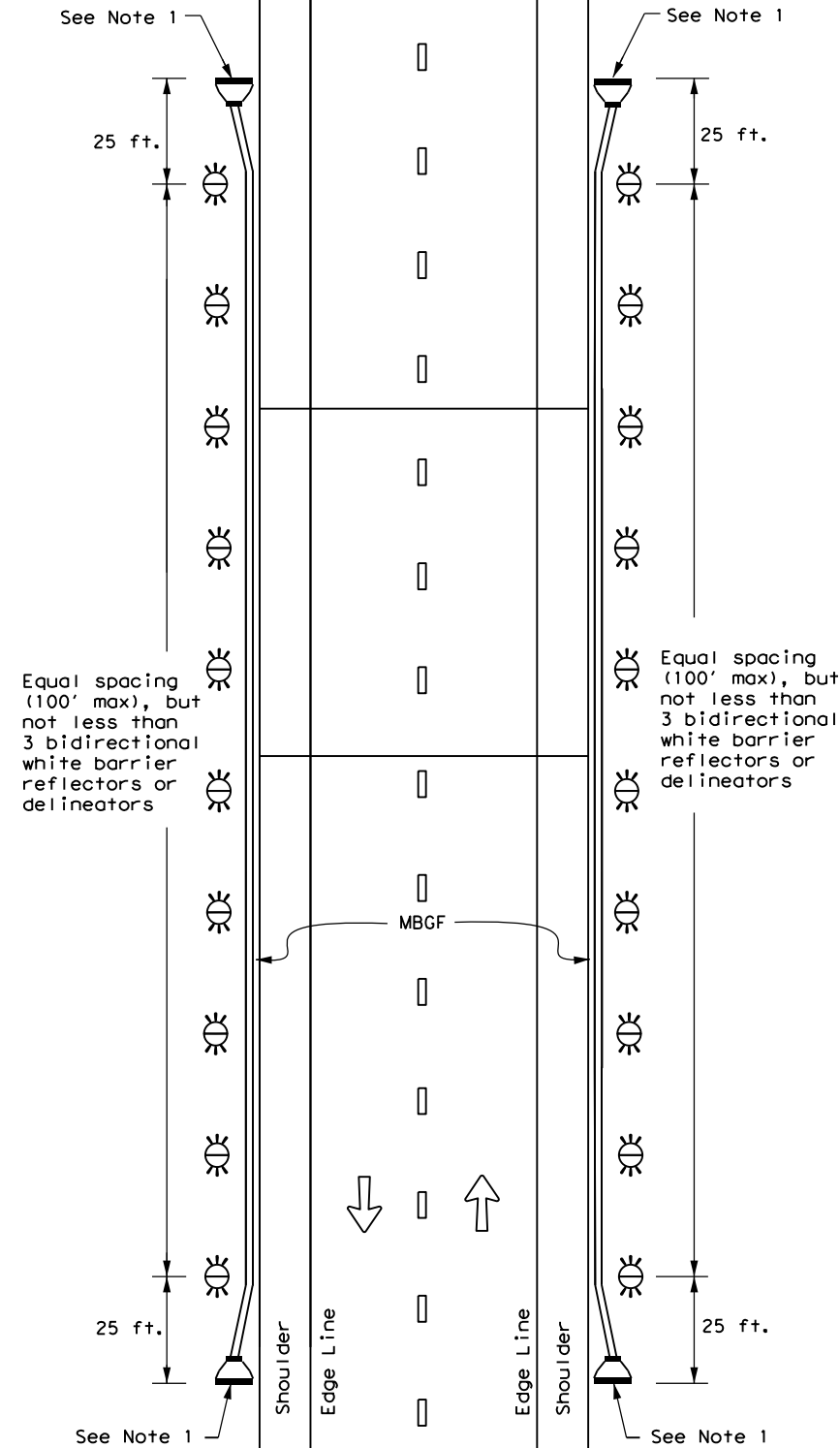

**NOTE:**

1. Terminal ends require reflective sheeting provided by manufacturer per D & OM (VIA) or a Type 3 Object Marker (OM-3) in front of the terminal end.

**TWO-WAY, TWO LANE ROADWAY  
BRIDGE WITH NO APPROACH RAIL**

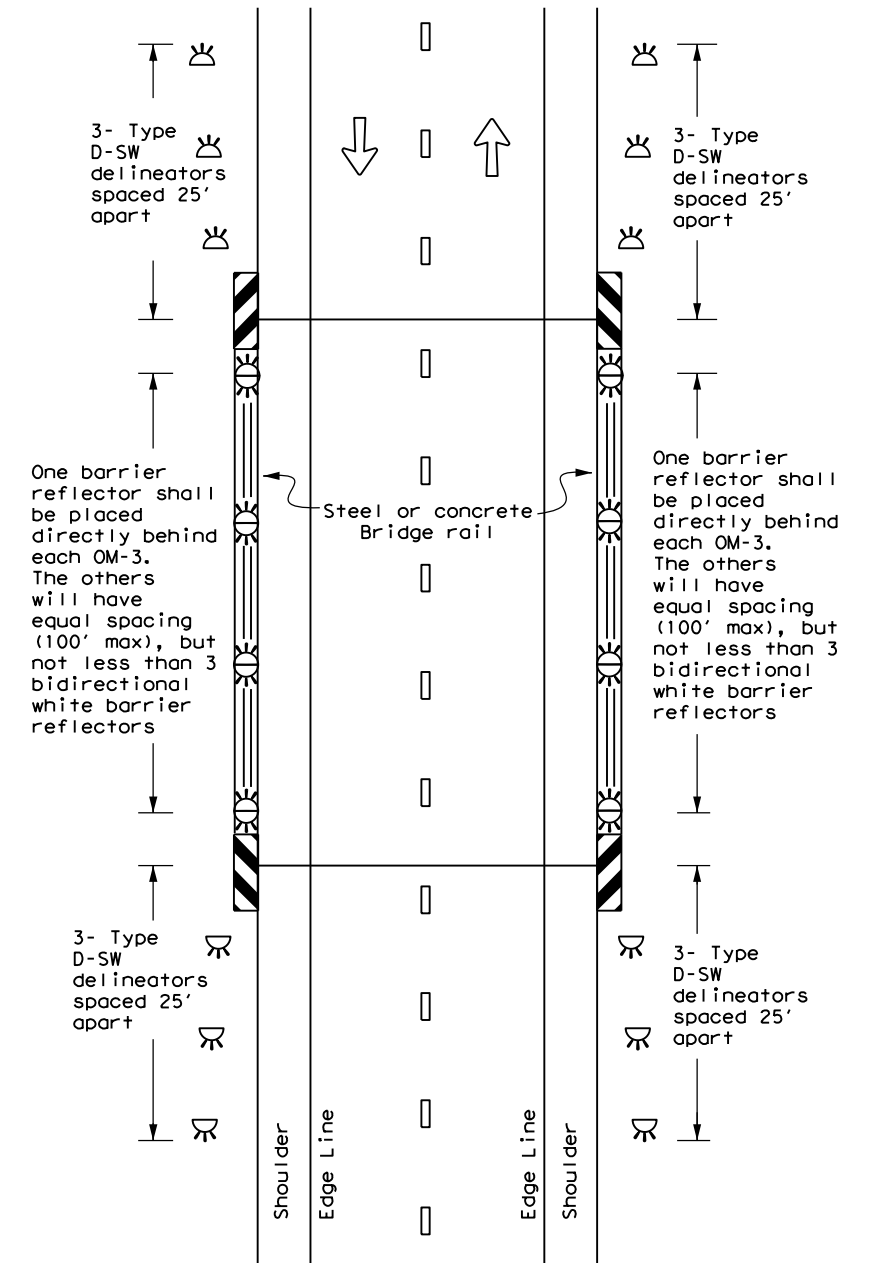

**LEGEND**

	Bidirectional Delineator
	Delineator
	OM-3
	OM-2
	Terminal End
	Traffic Flow



**DELINEATOR &  
OBJECT MARKER  
PLACEMENT DETAILS**

**D & OM(5)-20**

FILE: dom5-20.dgn	DN: TxDOT	CK: TxDOT	DW: TxDOT	CR: TxDOT
© TxDOT August 2015	CONT	SECT	JOB	HIGHWAY
REVISIONS	0918	00	392	VA
7-20	DIST	COUNTY	SHEET NO.	
	DAL	DALLAS, ETC.	109	

DISCLAIMER: The use of this standard is governed by the "Texas Engineering Practice Act". No warranty of any kind is made by TxDOT for any purpose whatsoever. TxDOT assumes no responsibility for the conversion of this standard to other formats or for incorrect results or damages resulting from its use.

DATE: FILE:

DISCLAIMER: The use of this standard is governed by the "Texas Engineering Practice Act". No warranty of any kind is made by TxDOT for any purpose whatsoever. TxDOT assumes no responsibility for the conversion of this standard to other formats or for incorrect results or damages resulting from its use.

### CONTINUOUS CONCRETE OR STEEL BARRIER

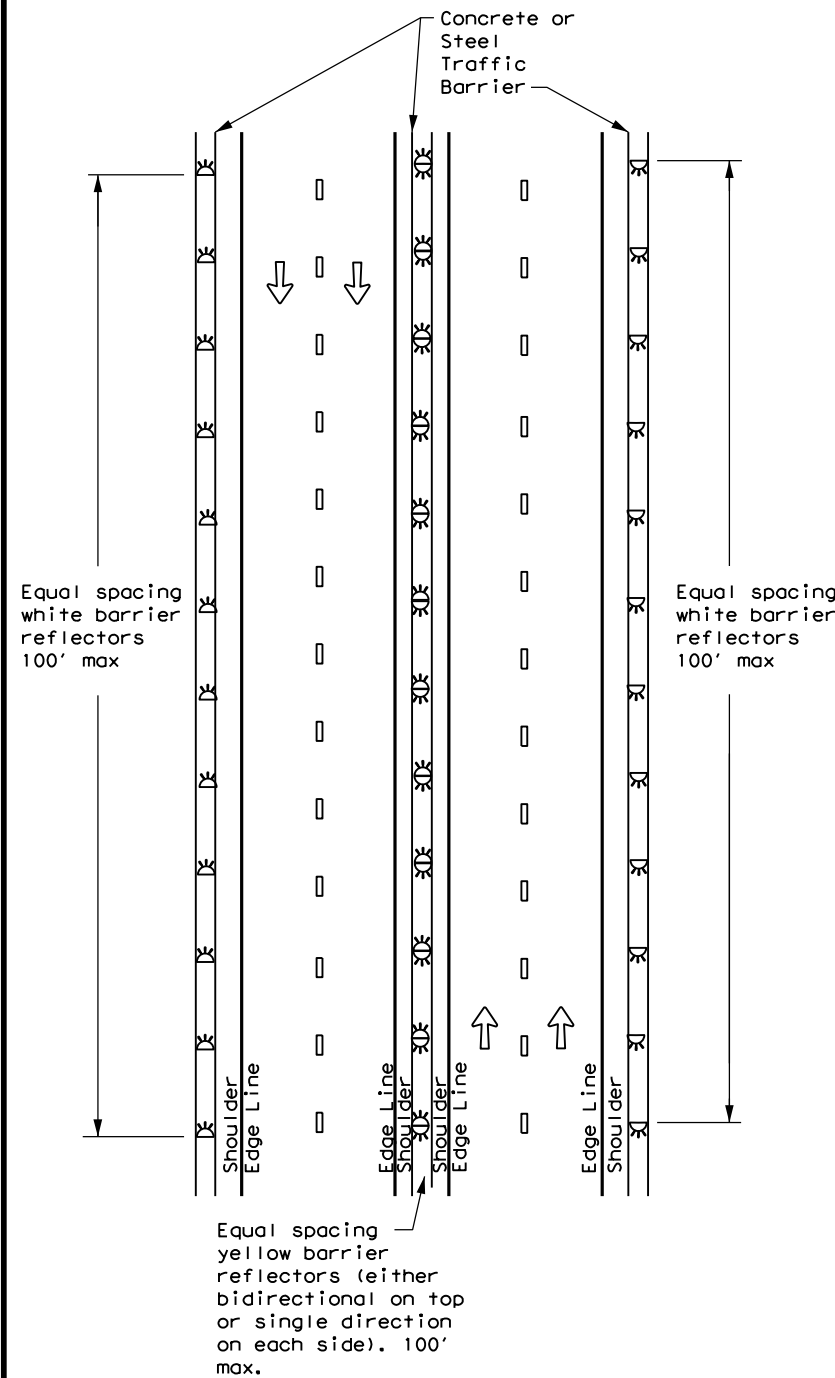

### MULTI-LANE UNDIVIDED, TWO-WAY ROADWAY WITH METAL BEAM GUARD FENCE (MBGF)

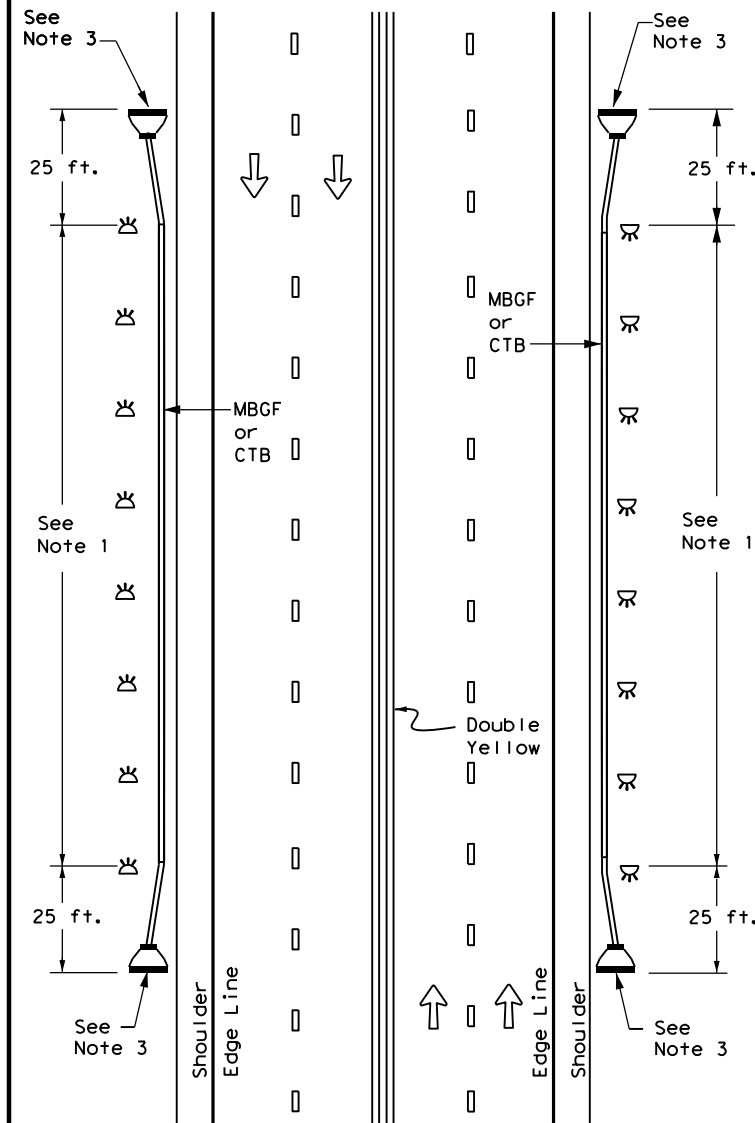

### DIVIDED ROADWAY WITH METAL BEAM GUARD FENCE (MBGF)

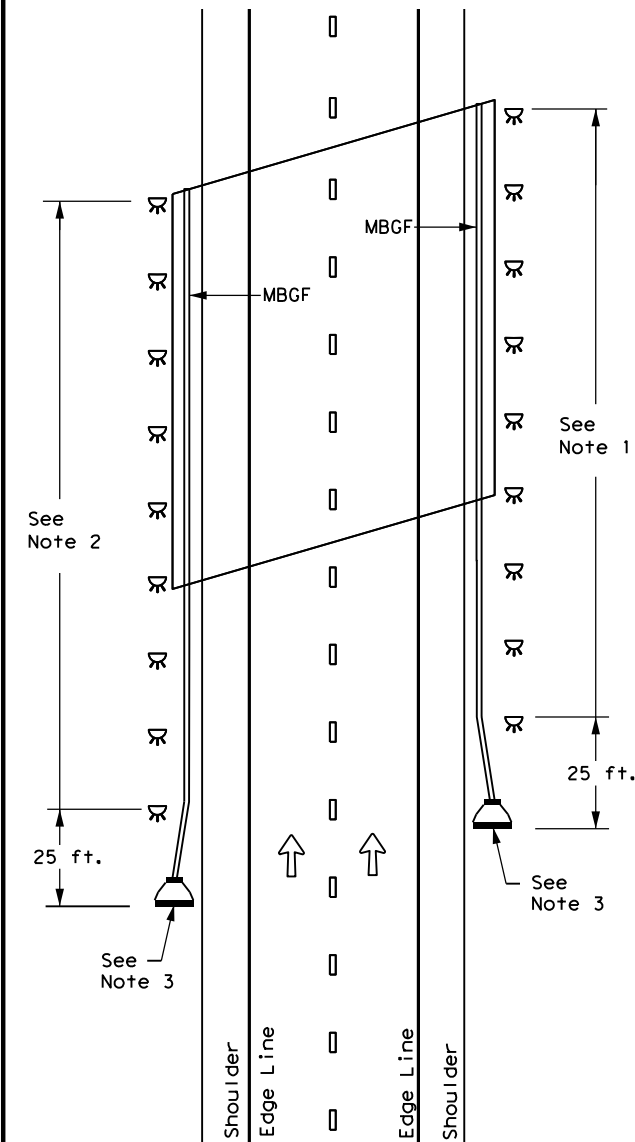

### EMERGENCY CROSSOVER

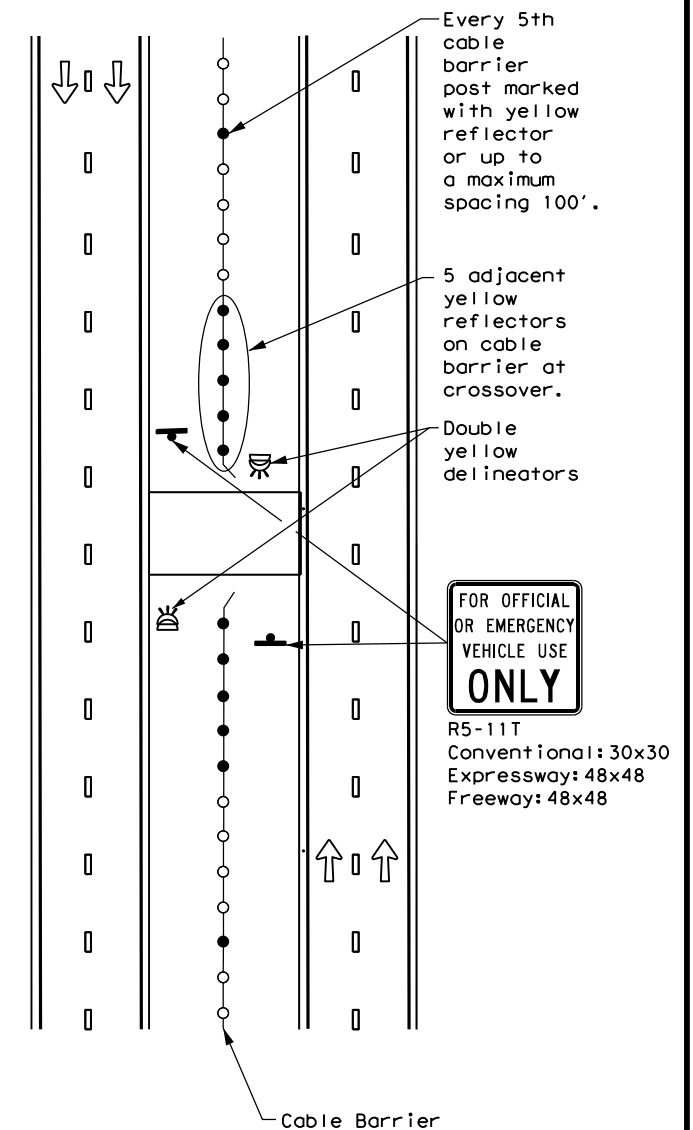

#### NOTES

1. Equal spacing (100' max), but not less than 3 single directional white barrier reflectors or delineators. On Continuous Barrier, equal spacing (100' max.)
2. Equal spacing (100' max), but not less than 3 single directional yellow barrier reflectors or delineators.
3. Terminal ends require reflective sheeting provided by manufacturer per D & OM (VIA) or a Type 3 Object Marker (OM-3) in front of the terminal end.

#### LEGEND

	Bidirectional Delineator
	Delineator
	OM-3
	OM-2
	Terminal End
	Traffic Flow



## DELINEATOR & OBJECT MARKER PLACEMENT DETAILS

### D & OM(6)-20

FILE: dom6-20.dgn	DN: TxDOT	CK: TxDOT	DW: TxDOT	CK: TxDOT
©TxDOT August 2015	CONT	SECT	JOB	HIGHWAY
7-20	0918	00	392	VA
DIST	COUNTY		SHEET NO.	
DAL	DALLAS, ETC.		110	

DATE:  
FILE:

**DISCLAIMER:**  
The use of this standard is governed by the "Texas Engineering Practice Act". No warranty of any kind is made by TxDOT for any purpose whatsoever. TxDOT assumes no responsibility for the conversion of this standard to other formats or for incorrect results or damage resulting from its use.

**Notes To Designer:**  
1. Do not alter Sheet Design or Font style, size or weight - match text attributes.  
2. If additional space is needed for a numbered section, fence and adjust sections up or down as needed for proportioning and readability but do not relocate from its relative position.  
3. All areas should be addressed thoroughly and verify the necessary pay items are set up to support actions needed.  
Filled Out: X/XX/XXXX  
Prepared By: Name/Section

**I. STORMWATER POLLUTION PREVENTION PLAN-CLEAN WATER ACT SECTION 402**

TPDES TXR 150000: Stormwater Discharge Permit or Construction General Permit required for projects with 1 or more acres disturbed soil. Projects with any disturbed soil must protect for erosion and sedimentation in accordance with Item 506.  
List adjacent MS 4 Operator(s) that receive discharges from this project. They need to be notified prior to construction activities.  
(Note: Leave blank only if no adjacent MS 4 Operator(s) are affected.)

1. County of Dallas MS4 Phase II contact Lissa Shepard, Senior Bridge Engineer and Floodplain Manager

No Action Required  Required Action

Action Number:

- Prevent stormwater pollution by controlling erosion and sedimentation in accordance with TPDES Permit TXR 150000.
- Comply with the SW3P and revise when necessary to control pollution or required by the Engineer.
- Post Construction Site Notice (CSN) with SW3P information on or near the site, accessible to the public and TCEQ, EPA or other inspectors.
- When Contractor project specific locations (PSL's) increase disturbed soil area to 5 acres or more, submit NOI to TCEQ and the Engineer.

**II. WORK IN OR NEAR STREAMS, WATERBODIES AND WETLANDS CLEAN WATER ACT SECTIONS 401 AND 404**

USACE Permit required for filling, dredging, excavating or other work in any water bodies, rivers, creeks, streams, wetlands or wet areas. No equipment is allowed in any stream channel below the ordinary High Water Mark except on approved temporary stream crossings or drill pads.

The Contractor must adhere to all of the terms and conditions associated with the following permit(s):

- No Permit Required  
 Nationwide Permit 14 - PCN not Required (less than 1/10th acre waters or wetlands affected)  
 Nationwide Permit 14 - PCN Required (1/10 to <1/2 acre, 1/3 in tidal waters)  
 Individual 404 Permit Required  
 Other Nationwide Permit Required:

Required Actions: List Waters of the US Permit applies to, location in project and check Best Management Practices planned to control erosion, sedimentation and post-project TSS.

- 
- 
- 

The elevation of the ordinary high water marks of any areas requiring work to be performed in the waters of the US requiring the use of a nationwide permit can be found on the Bridge Layouts.

Best Management Practices for applicable 401 General Conditions:  
(Note: If CORP Permit not required, do not check boxes.)

Erosion	Sedimentation	Post-Construction TSS
<input type="checkbox"/> Temporary Vegetation	<input type="checkbox"/> Silt Fence	<input type="checkbox"/> Vegetative Filter Strips
<input type="checkbox"/> Blankets/Matting	<input type="checkbox"/> Rock Berm	<input type="checkbox"/> Retention/Irrigation Systems
<input type="checkbox"/> Mulch	<input type="checkbox"/> Triangular Filter Dike	<input type="checkbox"/> Extended Detention Basin
<input type="checkbox"/> Sodding	<input type="checkbox"/> Sand Bag Berm	<input type="checkbox"/> Constructed Wetlands
<input type="checkbox"/> Interceptor Swale	<input type="checkbox"/> Straw Bale Dike	<input type="checkbox"/> Wet Basin
<input type="checkbox"/> Diversion Dike	<input type="checkbox"/> Brush Berms	<input type="checkbox"/> Erosion Control Compost
<input type="checkbox"/> Erosion Control Compost	<input type="checkbox"/> Erosion Control Compost	<input type="checkbox"/> Mulch Filter Berm and Socks
<input type="checkbox"/> Mulch Filter Berm and Socks	<input type="checkbox"/> Mulch Filter Berm and Socks	<input type="checkbox"/> Compost Filter Berm and Socks
<input type="checkbox"/> Compost Filter Berm and Socks	<input type="checkbox"/> Compost Filter Berm and Socks	<input type="checkbox"/> Vegetation Lined Ditches
	<input type="checkbox"/> Stone Outlet Sediment Traps	<input type="checkbox"/> Sand Filter Systems
	<input type="checkbox"/> Sediment Basins	<input type="checkbox"/> Grassy Swales

**III. CULTURAL RESOURCES**

Refer to TxDOT Standard Specifications in the event historical issues or archeological artifacts are found during construction. Upon discovery of archeological artifacts (bones, burnt rock, flint, pottery, etc.) cease work in the immediate area and contact the Engineer immediately.

No Action Required  Required Action

Action Number:

**IV. VEGETATION RESOURCES**

Preserve native vegetation to the extent practical.  
Contractor must adhere to Construction Specification Requirements Specs 162, 164, 192, 193, 506, 730, 751 & 752 in order to comply with requirements for invasive species, beneficial landscaping and tree/brush removal commitments.

No Action Required  Required Action

Action Number:

**V. FEDERAL LISTED, PROPOSED THREATENED, ENDANGERED SPECIES, CRITICAL HABITAT, STATE LISTED SPECIES, CANDIDATE SPECIES AND MIGRATORY BIRDS TREATY ACT.**

No Action Required  Required Action

Action Number:

1. Follow special notes.

**Special Notes:**

- Avoid harming all wildlife species if encountered and allow them to safely leave the project site. Due diligence should be used to avoid killing or harming any wildlife species in the implementation of transportation projects.
- If any of the listed species are observed, cease work in the immediate area, do not disturb species or habitat and contact the Engineer immediately. The work may not remove active nests from bridges and other structures during nesting season of the birds associated with the nests. If caves or sinkholes are discovered, cease work in the immediated area, and contact the Engineer immediately.
- The Migratory Bird Act of 1918 states that it is unlawful to kill, capture, collect, possess, buy, sell, trade or transport any migratory bird, nest, young, feather or egg in part or in whole, without a federal permit issued in accordance within the Act's policies and regulations. The contractor would remove all old migratory bird nests from any structure or trees where work would be done from October 1 to February 15. In addition, the contractor would be prepared to prevent migratory birds from building nest(s) between February 15 to October 1. In the event that migratory birds are encountered on-site during project construction, efforts to avoid adverse impacts on protected birds, active nests, eggs and/or young would be observed.

**LIST OF ABBREVIATIONS**

BMP: Best Management Practice	SPCC: Spill Prevention Control and Countermeasure
CGP: Construction General Permit	SW3P: Storm Water Pollution Prevention Plan
DSHS: Texas Department of State Health Services	PCN: Pre-Construction Notification
FHWA: Federal Highway Administration	PSL: Project Specific Location
MOA: Memorandum of Agreement	TCEQ: Texas Commission on Environmental Quality
MOU: Memorandum of Understanding	TPDES: Texas Pollutant Discharge Elimination System
MS4: Municipal Separate Stormwater Sewer System	TPWD: Texas Parks and Wildlife Department
MBTA: Migratory Bird Treaty Act	TxDOT: Texas Department of Transportation
NOT: Notice of Termination	T&E: Threatened and Endangered Species
NWP: Nationwide Permit	USACE: U.S. Army Corp of Engineers
NOI: Notice of Intent	USFWS: U.S. Fish and Wildlife Service

**VI. HAZARDOUS MATERIALS OR CONTAMINATION ISSUES**

General (applies to all projects):  
Comply with the Hazard Communication Act (the Act) for personnel who will be working with hazardous materials by conducting safety meetings prior to beginning construction and making workers aware of potential hazards in the workplace. Ensure that all workers are provided with personal protective equipment appropriate for any hazardous materials used. Obtain and keep on-site Safety Data Sheets (SDS) for all hazardous products used on the project, which may include, but are not limited to the following categories: Paints, acids, solvents, asphalt products, chemical additives, fuels and concrete curing compounds or additives. Provide protected storage, off bare ground and covered, for products which may be hazardous. Maintain product labelling as required by the Act. Maintain an adequate supply of on-site spill response materials, as indicated in the SDS. In the event of a spill, take actions to mitigate the spill as indicated in the SDS, in accordance with safe work practices, and contact the District Spill Coordinator immediately. The Contractor shall be responsible for the proper containment and cleanup of all product spills.

Contact the Engineer if any of the following are detected:

- \* Dead or distressed vegetation (not identified as normal)
- \* Trash piles, drums, canisters, barrels, etc.
- \* Undesirable smells or odors
- \* Evidence of leaching or seepage of substances

Does the project involve any bridge class structure rehabilitation(s) or replacement(s) (bridge class structures not including box culverts)?

Yes  No

If "No", then no further action is required.

If "Yes", then TxDOT is responsible for completing asbestos assessment/inspection.

Are the results of the asbestos inspection positive (is asbestos present)?

Yes  No

If "Yes", then TxDOT must retain a DSHS licensed asbestos consultant to assist with the notification, develop abatement/mitigation procedures, and perform management activities as necessary. The notification form to DSHS must be postmarked at least 15 working days prior to scheduled demolition.

If "No", then TxDOT is still required to notify DSHS 15 working days prior to any scheduled demolition.

In either case, the Contractor is responsible for providing the date(s) for abatement activities and/or demolition with careful coordination between the Engineer and asbestos consultant in order to minimize construction delays and subsequent claims.

Any other evidence indicating possible hazardous materials or contamination discovered on site. Hazardous Materials or Contamination Issues Specific to this Project:

No Action Required  Required Action

Action Number:

- 
- 
- 

**VII. OTHER ENVIRONMENTAL ISSUES**

(includes regional issues such as Edwards Aquifer District, etc.)

No Action Required  Required Action

Action Number:

- 

**GENERAL NOTE:**

Any change orders and/or deviations from the final design must be reported to the Engineer prior to commencement of construction activities, as additional environmental clearance may be required.

				
ENVIRONMENTAL PERMITS, ISSUES AND COMMITMENTS (EPIC)				
FED. RD. DIV. NO.	FEDERAL AID PROJECT NO.			HIGHWAY NO.
6	SEE TITLE SHEET			VA
STATE	DISTRICT	COUNTY		SHEET NO.
TEXAS	DALLAS	DALLAS, ETC.		
CONTROL	SECTION	JOB		
0918	00	392		111

**STORMWATER POLLUTION PREVENTION PLAN (SWP3):**

This SWP3 has been developed in accordance with TxDOT policy for projects disturbing less than 1 acre of soil, and not part of a larger common plan of development.

For all projects with any soil disturbing activities, TxDOT will maintain a SWP3 with all pertinent records, correspondence, environmental documents, etc. at the project field office. If no field office is available, then this SWP3 shall be kept at the appropriate TxDOT Area Office.

This SWP3 is consistent with requirements specified in applicable stormwater plans, and the project's environmental permits, issues, and commitments (EPICs).

**1.0 SITE/PROJECT DESCRIPTION**

**1.1 PROJECT CONTROL SECTION JOB (CSJ):**

0918-00-380

**1.2 PROJECT LIMITS:**

From: VARIOUS LOCATIONS

To: IN THE DALLAS DISTRICT

**1.3 PROJECT COORDINATES:**

BEGIN: (Lat) NA, (Long) NA

END: (Lat) NA, (Long) NA

**1.4 TOTAL PROJECT AREA (Acres):** \_\_\_\_\_

**1.5 TOTAL AREA TO BE DISTURBED (Acres):** 0.3

**1.6 NATURE OF CONSTRUCTION ACTIVITY:**

INSTALLATION OF TRAFFIC SIGNALS

**1.7 MAJOR SOIL TYPES:**

Soil Type	Description
NA	NA

**1.8 PROJECT SPECIFIC LOCATIONS (PSLs):**

PSLs must be depicted on the Environmental Layout Sheets in Attachment 1.2 of this SWP3. PSLs may be identified during preconstruction meetings or during the construction process. Please choose from the options below:

- PSLs determined during preconstruction meeting
- PSLs determined during construction
- No PSLs planned for construction

Type	Sheet #s
NA	NA

All off-ROW PSLs required by the Contractor are the Contractor's responsibility. The Contractor shall secure all permits required by local, state, federal laws for off-ROW PSLs. The contractor shall provide diagrams, areas of disturbance, acreage, and BMPs for all off-ROW PSLs within one mile of the project.

**1.9 CONSTRUCTION ACTIVITIES:**

(Use the following list as a starting point when developing the Construction Activity Schedule and Ceasing Record in Attachment 2.3.)

- Mobilization
- Install sediment and erosion controls
- Blade existing topsoil into windrows, prep ROW, clear and grub
- Remove existing pavement
- Grading operations, excavation, and embankment
- Excavate and prepare subgrade for proposed pavement widening
- Remove existing culverts, safety end treatments (SETs)
- Remove existing metal beam guard fence (MBGF), bridge rail
- Install proposed pavement per plans
- Install culverts, culvert extensions, SETs
- Install mow strip, MBGF, bridge rail
- Place flex base
- Rework slopes, grade ditches
- Blade windrowed material back across slopes
- Revegetation of unpaved areas
- Achieve site stabilization and remove sediment and erosion control measures

Other: \_\_\_\_\_

Other: \_\_\_\_\_

Other: \_\_\_\_\_

**1.10 POTENTIAL POLLUTANTS AND SOURCES:**

- Sediment laden stormwater from stormwater conveyance over disturbed area
- Fuels, oils, and lubricants from construction vehicles, equipment, and storage
- Solvents, paints, adhesives, etc. from various construction activities
- Transported soils from offsite vehicle tracking
- Construction debris and waste from various construction activities
- Contaminated water from excavation or dewatering pump-out water
- Sanitary waste from onsite restroom facilities
- Trash from various construction activities/receptacles
- Long-term stockpiles of material and waste
- Other: \_\_\_\_\_
- Other: \_\_\_\_\_
- Other: \_\_\_\_\_

**1.11 RECEIVING WATERS:**

Receiving waters must be depicted on the Environmental Layout Sheets in Attachment 1.2 of this SWP3. Include Segment # for receiving waters.

Tributaries	Classified Waterbody
NA	NA

\* Add (\*) for impaired waterbodies with pollutant in ( ).

**1.12 ROLES AND RESPONSIBILITIES: TxDOT**

- Development of plans and specifications
- Perform SWP3 inspections
- Maintain SWP3 records and update to reflect daily operations
- Other: \_\_\_\_\_
- Other: \_\_\_\_\_

**1.13 ROLES AND RESPONSIBILITIES: CONTRACTOR**

- Day To Day Operational Control
- Maintain schedule of major construction activities
- Install, maintain and modify BMPs
- Other: \_\_\_\_\_
- Other: \_\_\_\_\_

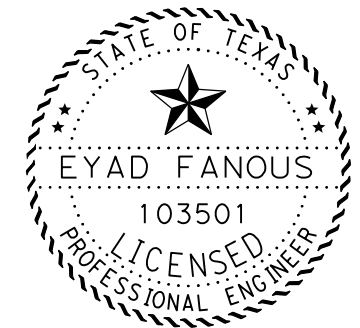

*Eyad Fanous*, P.E. 2/22/24  
Signature Date

**STORMWATER POLLUTION PREVENTION PLAN (SWP3) (Less Than 1 Acre)**

FED. RD. DIV. NO.	PROJECT NO.		SHEET NO.
6	(SEE TITLE SHEET)		112
STATE	STATE DIST.	COUNTY	
TEXAS	DAL	DALLAS, ETC.	
CONT.	SECT.	JOB	HIGHWAY NO.
0918	00	392	VA



**STORMWATER POLLUTION PREVENTION PLAN (SWP3):**

**2.0 BEST MANAGEMENT PRACTICES (BMPs) AND CONTROLS, INSPECTION, AND MAINTENANCE**

The Contractor shall be the responsible party for implementing the BMPs described herein and for complying with the SWP3 for control of erosion and sedimentation during day-to-day operations. The Contractor shall implement changes to this SWP3 approved by TxDOT within the times specified in this SWP3 or the CGP.

**2.1 EROSION CONTROL AND SOIL STABILIZATION BMPs:**

**T / P**

- Protection of Existing Vegetation
- Vegetated Buffer Zones
- Soil Retention Blankets
- Geotextiles
- Mulching/ Hydromulching
- Soil Surface Treatments
- Temporary Seeding
- Permanent Planting, Sodding or Seeding
- Biodegradable Erosion Control Logs
- Rock Filter Dams/ Rock Check Dams
- Vertical Tracking
- Interceptor Swale
- Riprap
- Diversion Dike
- Temporary Pipe Slope Drain
- Embankment for Erosion Control
- Paved Flumes
- Other: \_\_\_\_\_
- Other: \_\_\_\_\_
- Other: \_\_\_\_\_
- Other: \_\_\_\_\_

**2.2 SEDIMENT CONTROL BMPs:**

**T / P**

- Biodegradable Erosion Control Logs
- Dewatering Controls
- Inlet Protection
- Rock Filter Dams/ Rock Check Dams
- Sandbag Berms
- Sediment Control Fence
- Stabilized Construction Exit
- Floating Turbidity Barrier
- Vegetated Buffer Zones
- Vegetated Filter Strips
- Other: \_\_\_\_\_
- Other: \_\_\_\_\_
- Other: \_\_\_\_\_
- Other: \_\_\_\_\_

Refer to the Environmental Layout Sheets/ SWP3 Layout Sheets located in Attachment 1.2 of this SWP3

**2.3 PERMANENT CONTROLS:**

(Coordinate post-construction BMPs with appropriate TxDOT maintenance sections.)

BMPs To Be Left In Place Post Construction:

Type	Stationing	
	From	To
NA	NA	NA

Refer to the Environmental Layout Sheets/ SWP3 Layout Sheets located in Attachment 1.2 of this SWP3

**2.4 OFFSITE VEHICLE TRACKING CONTROLS:**

- Excess dirt/mud on road removed daily
- Haul roads dampened for dust control
- Loaded haul trucks to be covered with tarpaulin
- Stabilized construction exit
- Other: \_\_\_\_\_

- Other: \_\_\_\_\_
- Other: \_\_\_\_\_
- Other: \_\_\_\_\_

\_\_\_\_\_

**2.5 POLLUTION PREVENTION MEASURES:**

- Chemical Management
- Concrete and Materials Waste Management
- Debris and Trash Management
- Dust Control
- Sanitary Facilities
- Other: \_\_\_\_\_
- Other: \_\_\_\_\_
- Other: \_\_\_\_\_
- Other: \_\_\_\_\_

**2.6 VEGETATED BUFFER ZONES:**

Natural vegetated buffers shall be maintained as feasible to protect adjacent surface waters. If vegetated natural buffer zones are not feasible due to site geometry, the appropriate additional sediment control measures have been incorporated into this SWP3.

Type	Stationing	
	From	To

Refer to the Environmental Layout Sheets/ SWP3 Layout Sheets located in Attachment 1.2 of this SWP3

**2.7 ALLOWABLE NON-STORMWATER DISCHARGES:**

- Fire hydrant flushings
- Irrigation drainage
- Pavement washwater (where spills or leaks have not occurred, and detergents are not used)
- Potable water sources
- Springs
- Uncontaminated groundwater
- Water used to wash vehicles or control dust
- Other allowable non-stormwater discharges as allowed by TPDES GP TXR150000.

**2.8 INSPECTIONS:**

All disturbed areas and erosion and sediment control devices shall be inspected at least once every seven (7) days. Inspections shall be performed by TxDOT as indicated on the Field Inspection and Maintenance Report Form 2118 and retained in Attachment 2.3 of this SWP3 .

**2.9 MAINTENANCE:**

Control measures shall be properly installed according to specifications. If it is determined that a BMP or control measure is not operating effectively, maintenance must be accomplished as soon as possible and before the next anticipated rain event, but in no case later than 7 calendar days after being able to access the site. Maintenance shall be performed by the Contractor as indicated on the Field Inspection and Maintenance Report Form 2118 and retained in Attachment 2.3 of this SWP3.

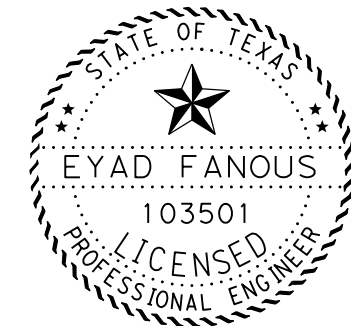

Eyad Fanous ,P.E. 2/22/24  
Signature Date

**STORMWATER POLLUTION PREVENTION PLAN (SWP3) (Less Than 1 Acre)**

FED. RD. DIV. NO.	PROJECT NO.		SHEET NO.
6	(SEE TITLE SHEET)		113
STATE	STATE DIST.	COUNTY	
TEXAS	DAL	DALLAS, ETC.	
CONT.	SECT.	JOB	HIGHWAY NO.
0918	00	392	VA

DISCLAIMER: The use of this standard is governed by the "Texas Engineering Practice Act". No warranty of any kind is made by TxDOT for any purpose whatsoever. TxDOT assumes no responsibility for the conversion of this standard to other formats or for incorrect results or damages resulting from its use.

DATE: 2/22/2024 2:19:43 PM  
 U:\TRAFFIC PROJECTS\0918-00-392 Non-Site 9-24\Microstation Files\114-116 EC(9)-16.dgn

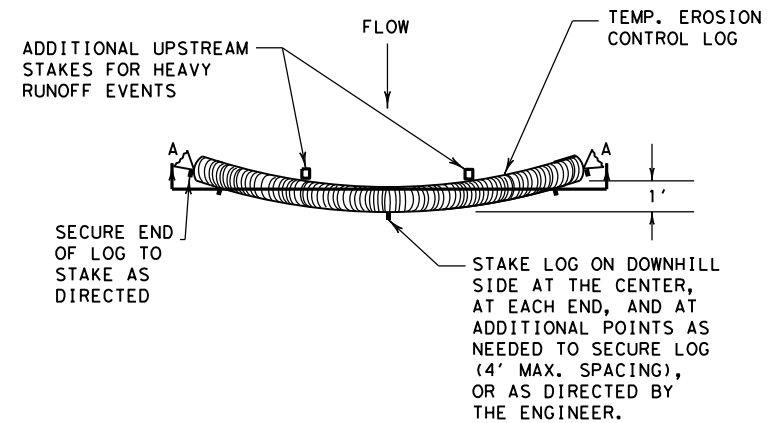

PLAN VIEW

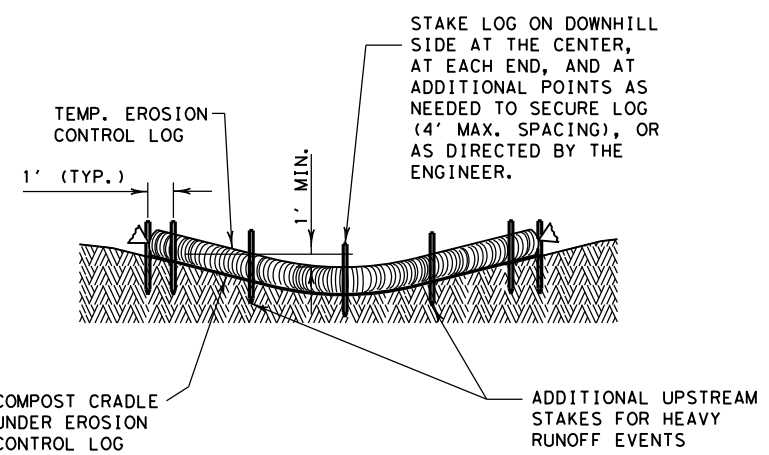

SECTION A-A

EROSION CONTROL LOG DAM

CL-D

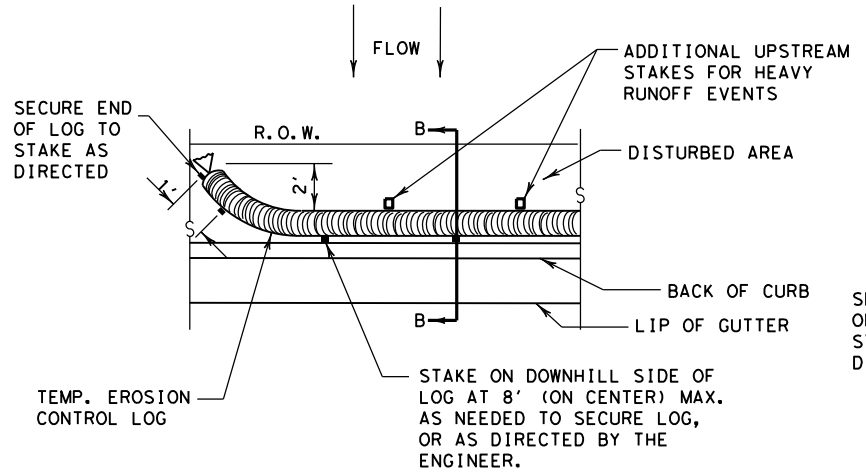

PLAN VIEW

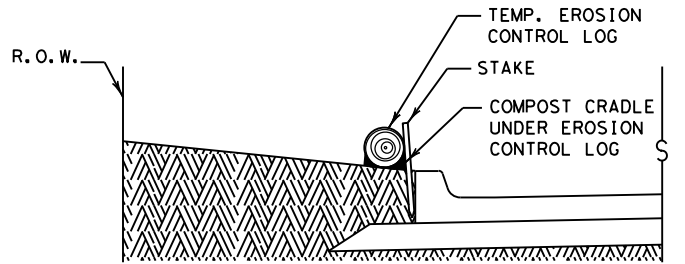

SECTION B-B

EROSION CONTROL LOG AT BACK OF CURB

CL-BOC

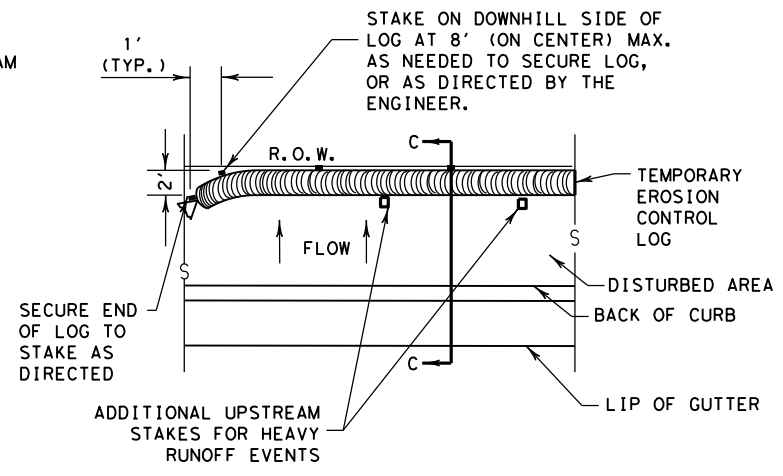

PLAN VIEW

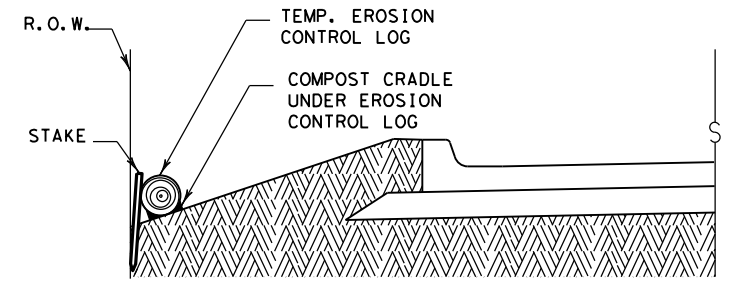

SECTION C-C

EROSION CONTROL LOG AT EDGE OF RIGHT-OF-WAY

CL-ROW

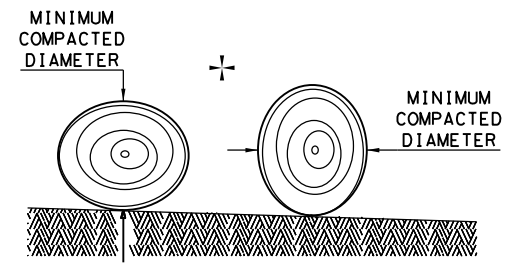

DIAMETER MEASUREMENTS OF EROSION CONTROL LOGS SPECIFIED IN PLANS

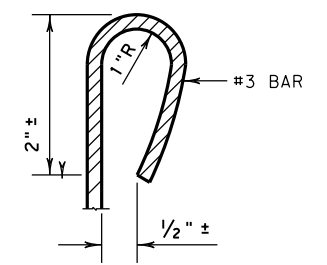

REBAR STAKE DETAIL

**SEDIMENT BASIN & TRAP USAGE GUIDELINES**

An erosion control log sediment trap may be used to filter sediment out of runoff draining from an unstabilized area.

**Log Traps:** The drainage area for a sediment trap should not exceed 5 acres. The trap capacity should be 1800 CF/Acre (0.5" over the drainage area).

Control logs should be placed in the following locations:

1. Within drainage ditches spaced as needed or min. 500' on center
2. Immediately preceding ditch inlets or drain inlets
3. Just before the drainage enters a water course
4. Just before the drainage leaves the right of way
5. Just before the drainage leaves the construction limits where drainage flows away from the project.

The logs should be cleaned when the sediment has accumulated to a depth of 1/2 the log diameter.

Cleaning and removal of accumulated sediment deposits is incidental and will not be paid for separately.

- GENERAL NOTES:**
1. EROSION CONTROL LOGS SHALL BE INSTALLED IN ACCORDANCE WITH MANUFACTURER'S RECOMMENDATIONS, OR AS DIRECTED BY THE ENGINEER.
  2. LENGTHS OF EROSION CONTROL LOGS SHALL BE IN ACCORDANCE WITH MANUFACTURER'S RECOMMENDATIONS AND AS REQUIRED FOR THE PURPOSE INTENDED.
  3. UNLESS OTHERWISE DIRECTED, USE BIODEGRADABLE OR PHOTODEGRADABLE CONTAINMENT MESH ONLY WHERE LOG WILL REMAIN IN PLACE AS PART OF A VEGETATIVE SYSTEM. FOR TEMPORARY INSTALLATIONS, USE RECYCLABLE CONTAINMENT MESH.
  4. FILL LOGS WITH SUFFICIENT FILTER MATERIAL TO ACHIEVE THE MINIMUM COMPACTED DIAMETER SPECIFIED IN THE PLANS WITHOUT EXCESSIVE DEFORMATION.
  5. STAKES SHALL BE 2" X 2" WOOD OR #3 REBAR, 2'-4' LONG, EMBEDDED SUCH THAT 2" PROTRUDES ABOVE LOG, OR AS DIRECTED BY THE ENGINEER.
  6. DO NOT PLACE STAKES THROUGH CONTAINMENT MESH.
  7. COMPOST CRADLE MATERIAL IS INCIDENTAL & WILL NOT BE PAID FOR SEPARATELY.
  8. SANDBAGS USED AS ANCHORS SHALL BE PLACED ON TOP OF LOGS & SHALL BE OF SUFFICIENT SIZE TO HOLD LOGS IN PLACE.
  9. TURN THE ENDS OF EACH ROW OF LOGS UPSLOPE TO PREVENT RUNOFF FROM FLOWING AROUND THE LOG.
  10. FOR HEAVY RUNOFF EVENTS, ADDITIONAL UPSTREAM STAKES MAY BE NECESSARY TO KEEP LOG FROM FOLDING IN ON ITSELF.

- LEGEND**
- CL-D EROSION CONTROL LOG DAM
  - CL-BOC EROSION CONTROL LOG AT BACK OF CURB
  - CL-ROW EROSION CONTROL LOG AT EDGE OF RIGHT-OF-WAY
  - CL-SST EROSION CONTROL LOGS ON SLOPES STAKE AND TRENCHING ANCHORING
  - CL-SSL EROSION CONTROL LOGS ON SLOPES STAKE AND LASHING ANCHORING
  - CL-DI EROSION CONTROL LOG AT DROP INLET
  - CL-CI EROSION CONTROL LOG AT CURB INLET
  - CL-GI EROSION CONTROL LOG AT CURB & GRATE INLET

SHEET 1 OF 3

Design Division Standard

**TEMPORARY EROSION, SEDIMENT AND WATER POLLUTION CONTROL MEASURES**

**EROSION CONTROL LOG**

**EC(9)-16**

FILE: ec916	DN: TxDOT	CK: KM	DW: LS/PT	CK: LS
© TxDOT: JULY 2016	CONT	SECT	JOB	HIGHWAY
REVISIONS	0918	00	392	VA
DIST	COUNTY		SHEET NO.	
DAL	DALLAS, ETC.		114	

DATE: 2/22/2024 2:20:07 PM  
 U:\TRAFFIC PROJECTS\0918-00-392 Non-Site 9-24\Microstation Files\114-116 EC(9)-16.dgn  
 DISCLAIMER: The use of this standard is governed by the "Texas Engineering Practice Act". No warranty of any kind is made by TxDOT for any purpose whatsoever. TxDOT assumes no responsibility for the conversion of this standard to other formats or for incorrect results or damages resulting from its use.

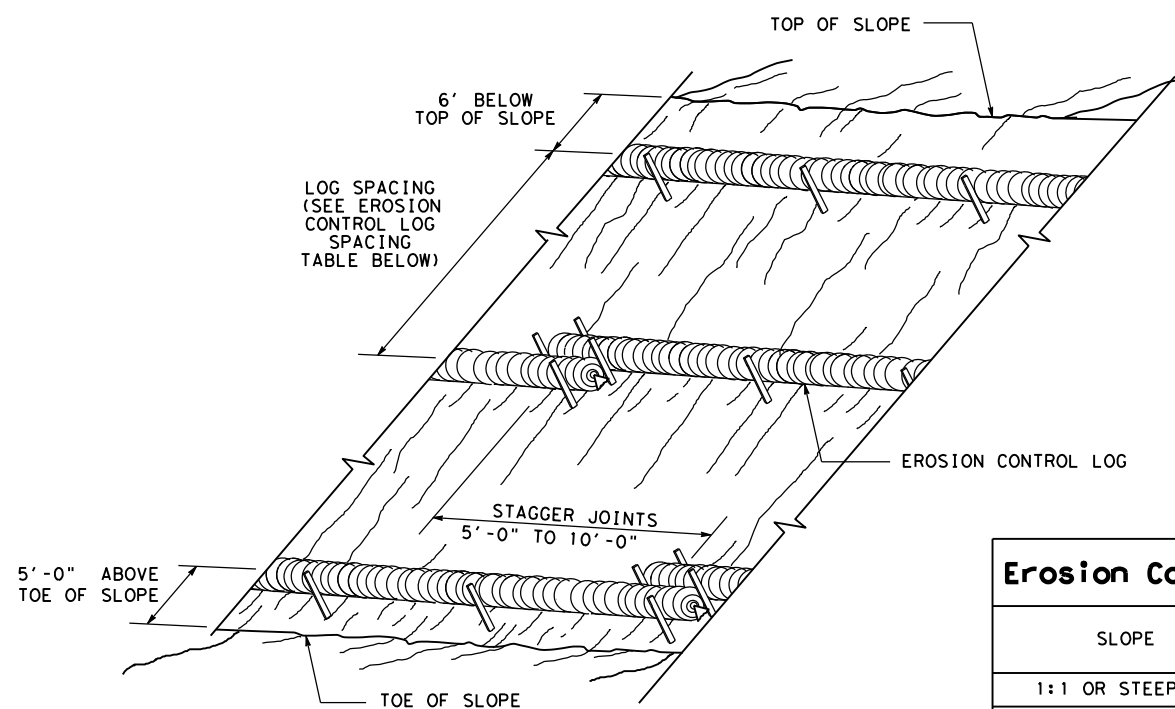

EROSION CONTROL LOGS ON SLOPES  
STAKE AND TRENCHING ANCHORING

CL-SST

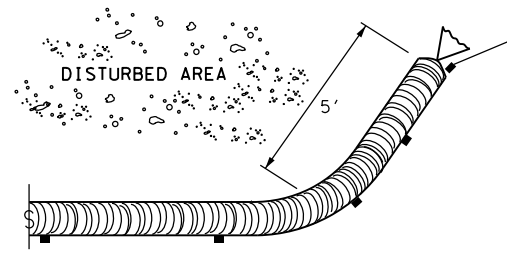

END SECTION RAP DETAIL

SLOPE	LOG DIAMETER			
	6"	8"	12"	18"
1:1 OR STEEPER	5'	10'	15'	20'
2:1	10'	20'	30'	40'
3:1	15'	30'	45'	60'
4:1 OR FLATTER	20'	40'	60'	80'

\* ADJUSTMENTS CAN BE MADE FOR SOIL TYPE:  
SOFT, LOAMY SOILS-ADJUST ROWS CLOSER TOGETHER;  
HARD, ROCKY SOILS- ADJUST ROWS FARTHER APART

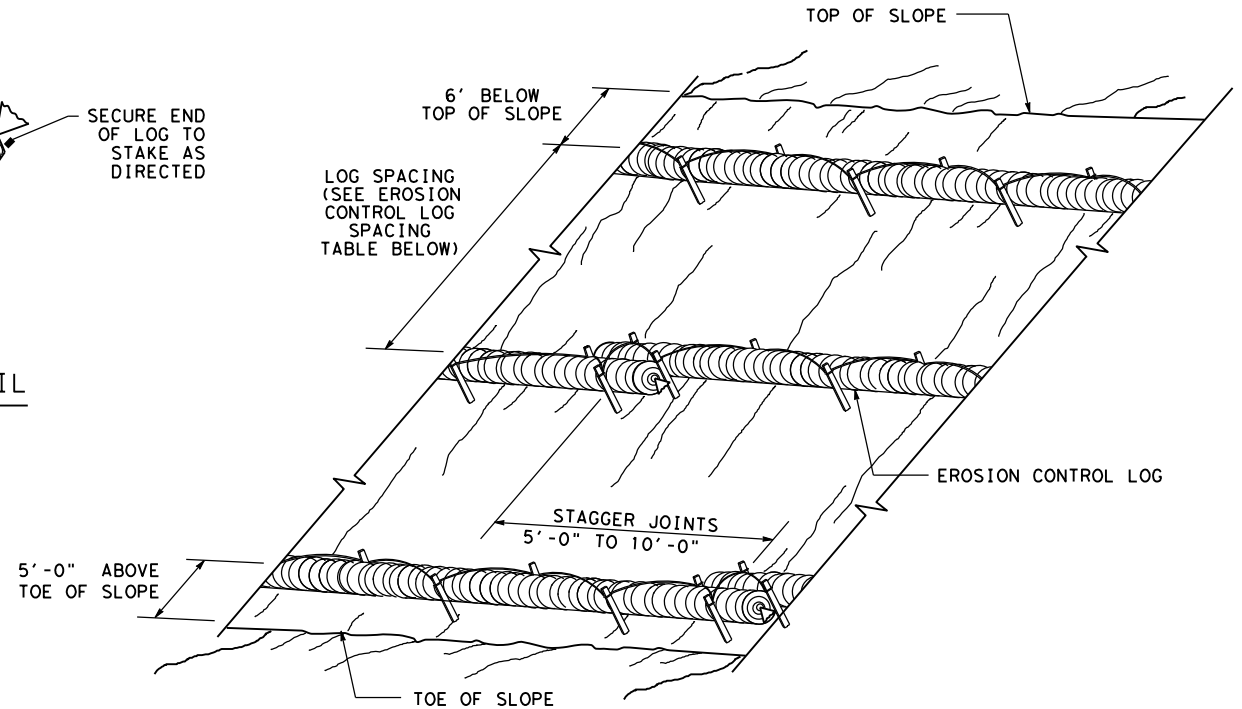

EROSION CONTROL LOGS ON SLOPES  
STAKE AND LASHING ANCHORING

CL-SSL

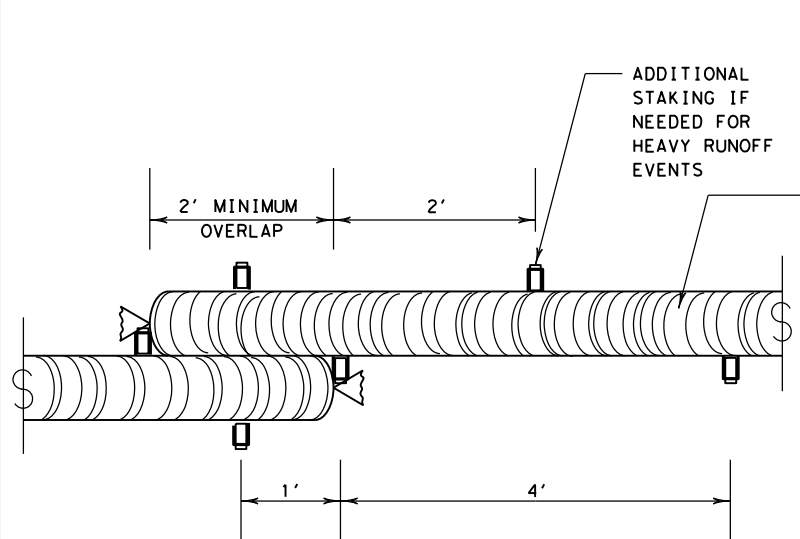

STAKE AND TRENCHING ANCHORING DETAIL

CL-SST

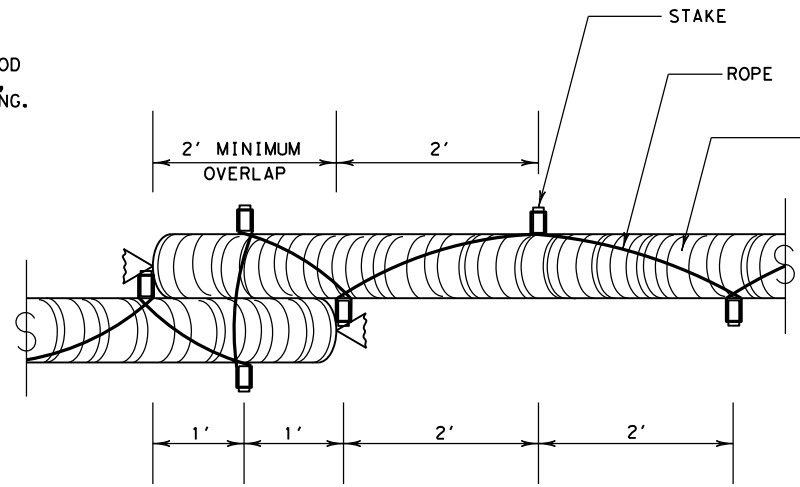
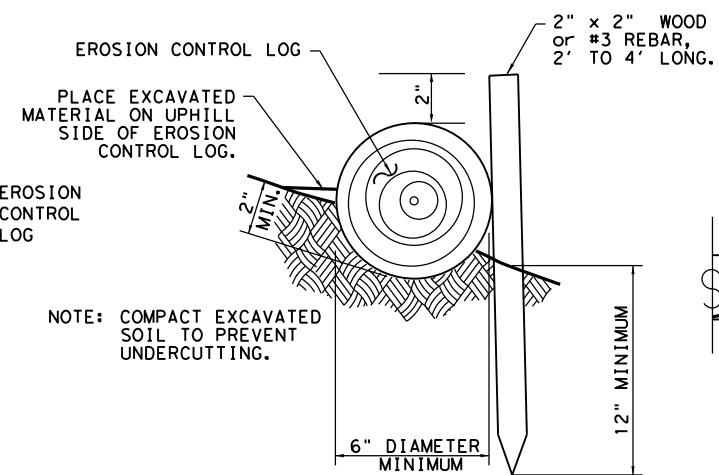

STAKE AND LASHING ANCHORING DETAIL

CL-SSL

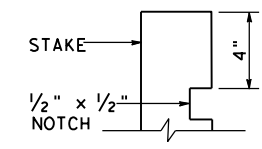

STAKE NOTCH DETAIL

LOG DIAMETER	DEPTH
6"	2"
8"	3"
12"	4"
18"	5"

SHEET 2 OF 3

		Design Division Standard	
<b>TEMPORARY EROSION, SEDIMENT AND WATER POLLUTION CONTROL MEASURES</b> <b>EROSION CONTROL LOG</b> <b>EC(9) - 16</b>			
FILE: ec116	DN: TxDOT	CK: KM	DW: LS/PT
© TxDOT: JULY 2016	CONT SECT	JOB	HIGHWAY
REVISIONS	0918 00	392	VA
DIST	COUNTY	SHEET NO.	
DAL	DALLAS, ETC.	115	

DATE: 2/22/2024 2:20:46 PM  
 U:\TRAFFIC PROJECTS\0918-00-392 Non-Site 9-24\Microstation Files\114-116 EC(9)-16.dgn  
 DISCLAIMER:  
 The use of this standard is governed by the "Texas Engineering Practice Act". No warranty of any kind is made by TxDOT for any purpose whatsoever. TxDOT assumes no responsibility for the conversion of this standard to other formats or for incorrect results or damages resulting from its use.

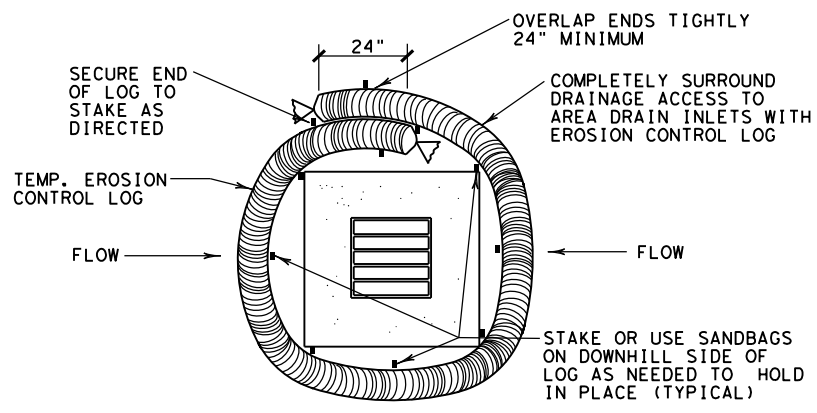

EROSION CONTROL LOG AT DROP INLET

CL-DI

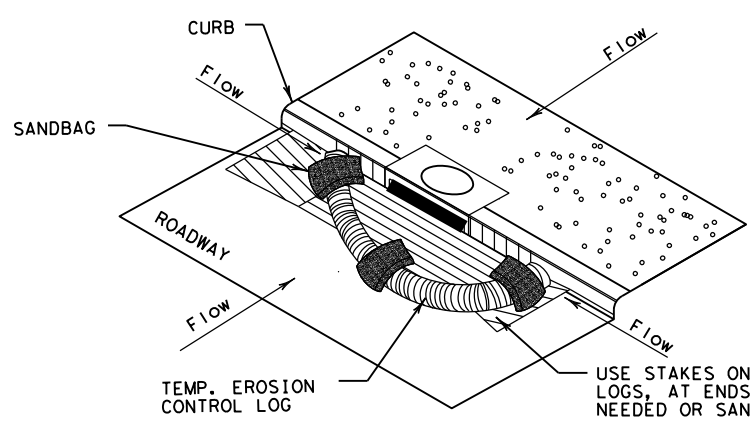

EROSION CONTROL LOG AT CURB INLET

CL-CI

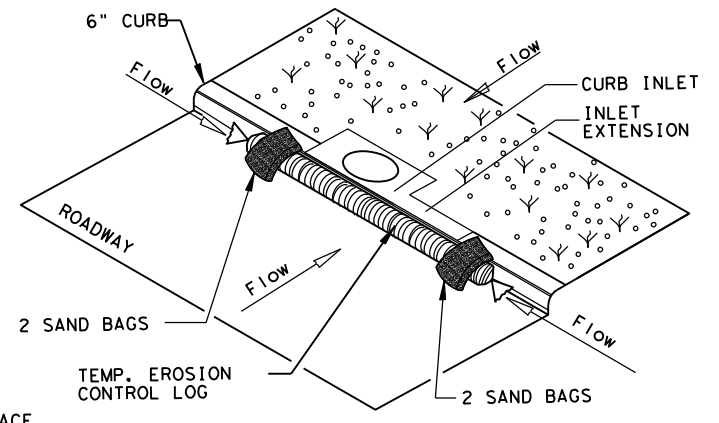

EROSION CONTROL LOG AT CURB INLET

CL-CI

NOTE:  
 EROSION CONTROL LOGS USED AT CURB INLETS SHOULD ONLY BE USED IF THEY WILL NOT IMPEDE TRAFFIC OR FLOOD THE ROADWAY OR WHEN THE STORM SEWER SYSTEM IS NOT FULLY FUNCTIONAL.

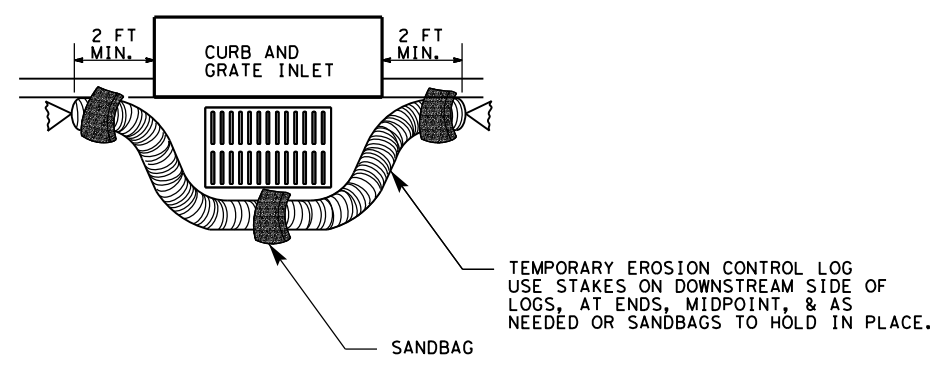

EROSION CONTROL LOG AT CURB & GRADE INLET

CL-GI

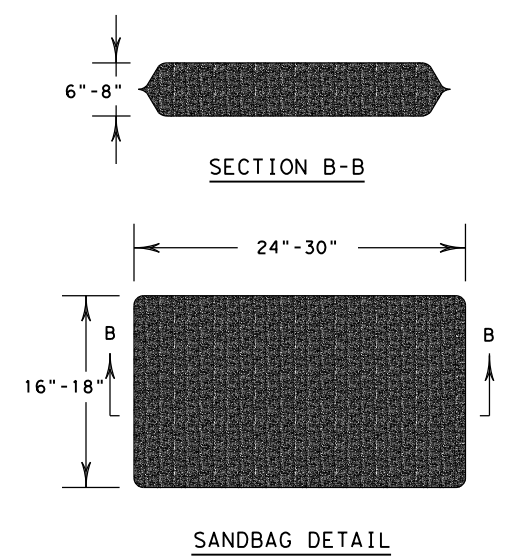

SHEET 3 OF 3

		<i>Design Division Standard</i>	
<b>TEMPORARY EROSION, SEDIMENT AND WATER POLLUTION CONTROL MEASURES</b> <b>EROSION CONTROL LOG</b> <b>EC (9) - 16</b>			
FILE: ec916	DN: TxDOT	CK: KM	DW: LS/PT
© TxDOT: JULY 2016	CONT SECT	JOB	HIGHWAY
REVISIONS	0918 00	392	VA
DIST	COUNTY	SHEET NO.	
DAL	DALLAS, ETC.	116	