

INDEX OF SHEETS

SHEET NUMBER	DESCRIPTION
1	TITLE SHEET
2	INDEX OF SHEETS

# STATE OF TEXAS DEPARTMENT OF TRANSPORTATION

## PLANS OF PROPOSED STATE HIGHWAY IMPROVEMENT

FEDERAL AID PROJECT F2B24(139)

FM 1709

TARRANT COUNTY

NET LENGTH OF PROJECT = 3,700 FT = 0.701 MI  
LMA# 02-KELLER-LMA-0001

FEDERAL AID PROJECT NO.			
F2B24(139)			
COUNTY	SECTION	JOB	MARKET
1603	03	042	FM 1709
DISTRICT		COUNTY	SHEET NO.
FTW		TARRANT	1

FUNCTIONAL CLASS:  
DESIGN SPEED: 45 MPH  
AADT 2022: 31,088  
AADT 2042: 43,523

FOR THE CONSTRUCTION OF LANDSCAPE AND SCENIC ENHANCEMENT WORK  
CONSISTING OF: HARDSCAPE, IRRIGATION, AND PLANTING

PLANS PREPARED BY:

**Kimley»Horn**

TEXAS REGISTERED ENGINEERING FIRM # F-928  
801 CHERRY STREET, UNIT 11, SUITE 1300  
FORT WORTH, TX 76102  
P: 817-335-6511



NOTE:

SPECIFICATIONS ADOPTED BY THE TEXAS DEPARTMENT OF TRANSPORTATION, NOVEMBER 1, 2014, AND THE CONTRACT PROVISIONS LISTED AND DATED AS FOLLOWS SHALL GOVERN ON THIS PROJECT: REQUIRED CONTRACT PROVISIONS FOR ALL FEDERAL-AID CONSTRUCTION CONTRACTS (FORM FHWA 1273, OCTOBER, 2023)

THE CITY-STATE CONSTRUCTION, MAINTENANCE AND OPERATION RESPONSIBILITIES SHALL BE AS HERETOFORE AGREED TO, ACCEPTED, AND SPECIFIED IN THE AGREEMENT TO WHICH THESE PLANS ARE MADE A PART.

LANDSCAPE MAINTENANCE AGREEMENT (LMA) NUMBER: 02-KELLER-LMA-0001

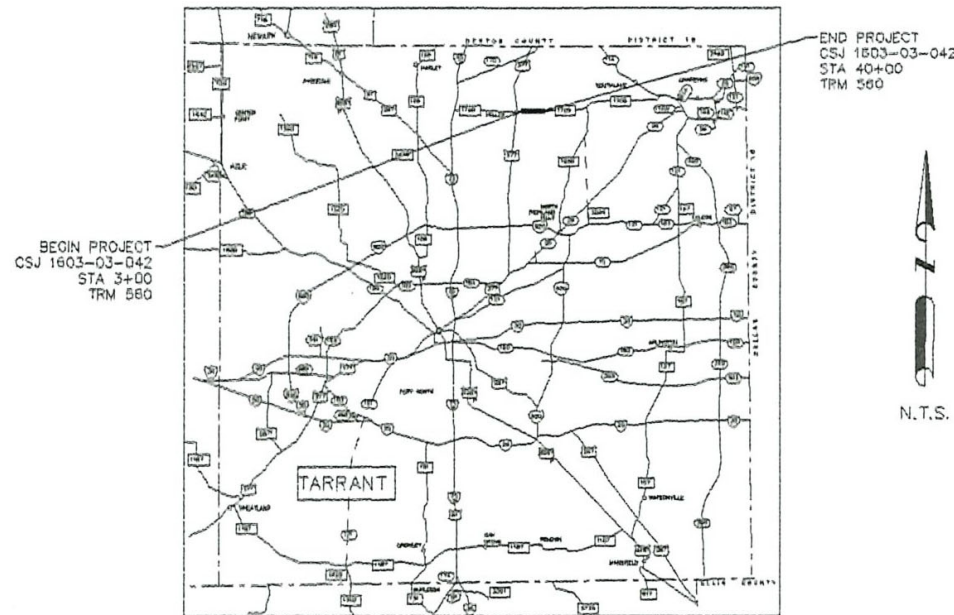

CORRECTED FOR LETTING: 04/10/2024

*Laura Presley*  
PROJECT MANAGER  
KIMLEY-HORN AND ASSOCIATES, INC.

CONCURRENCE: 04/10/2024

*David M. Salazar*  
CITY MANAGER  
CITY OF KELLER

FINAL PLANS

NAME OF CONTRACTOR: \_\_\_\_\_  
DATE OF LETTING: \_\_\_\_\_  
DATE WORK BEGAN: \_\_\_\_\_  
DATE WORK COMPLETED: \_\_\_\_\_  
DATE WORK ACCEPTED: \_\_\_\_\_

TEXAS DEPARTMENT OF TRANSPORTATION

DocuSigned by: *[Signature]*  
SUBMITTED FOR LETTING: 4/10/2024  
7B89CC87CF28477...

RECOMMENDED FOR LETTING: 4/12/2024

DocuSigned by: *[Signature]*  
DIRECTOR OF TRANSPORTATION & DEVELOPMENT  
78790082550403

APPROVED FOR LETTING: 4/12/2024

DocuSigned by: *David M. Salazar, P.E.*  
DISTRICT ENGINEER  
B741E64FAD82411

NO EQUATIONS  
NO EXCEPTIONS  
NO RAILROAD CROSSINGS  
NO TDLR REQUIRED

**FINAL**  
**FINAL SUBMITTAL**

**INDEX OF SHEETS**

SHEET NUMBER	DESCRIPTION
<b>GENERAL</b>	
001	TITLE SHEET
002	INDEX OF SHEETS
003	OVERALL LAYOUT PLAN
004	SUMMARY OF QUANTITIES
005, 5A - 5C	GENERAL NOTES
006	ESTIMATE AND QUANTITY SHEET
<b>EXISTING CONDITIONS</b>	
007	EXISTING CONDITIONS BEGIN STA. 3+00 TO END STA. 7+00 BEGIN STA. 12+00 TO END STA. 17+00
008	EXISTING CONDITIONS BEGIN STA. 22+00 TO END STA. 29+00 BEGIN STA. 34+00 TO END STA. 40+00
<b>TRAFFIC</b>	
009	TCP (2-5) - 18*
010	WZ (BRK) - 13*
011	BC (1) - 21*
012	BC (2) - 21*
013	BC (3) - 21*
014	BC (4) - 21*
015	BC (5) - 21*
016	BC (6) - 21*
017	BC (7) - 21*
018	BC (8) - 21*
019	BC (9) - 21*
020	BC (10) - 21*
021	BC (11) - 21*
022	BC (12) - 21*
023	EDGECON - 21*
024	TRAFFIC CONTROL & SEQUENCE OF WORK
<b>HARDSCAPE</b>	
025	HARDSCAPE PLAN BEGIN STA. 3+00 TO END STA. 7+00 BEGIN STA. 12+00 TO END STA. 17+00
026	HARDSCAPE PLAN BEGIN STA. 22+00 TO END STA. 29+00 BEGIN STA. 34+00 TO END STA. 40+00
027	HARDSCAPE DETAILS
<b>LANDSCAPE</b>	
028	LANDSCAPE PLAN BEGIN STA. 3+00 TO END STA. 7+00 BEGIN STA. 12+00 TO END STA. 17+00
029	LANDSCAPE PLAN BEGIN STA. 22+00 TO END STA. 29+00 BEGIN STA. 34+00 TO END STA. 40+00
030	LANDSCAPE DETAILS
031	LANDSCAPE DETAILS
032	LANDSCAPE SPECIFICATIONS
<b>IRRIGATION</b>	
033	IRRIGATION PLAN BEGIN STA. 3+00 TO END STA. 7+00 BEGIN STA. 12+00 TO END STA. 17+00
034	IRRIGATION PLAN BEGIN STA. 22+00 TO END STA. 29+00 BEGIN STA. 34+00 TO END STA. 40+00
035	IRRIGATION SCHEDULES
036	IRRIGATION DETAILS
037	IRRIGATION GENERAL NOTES
038	IRRIGATION SPECIFICATIONS
<b>EROSION CONTROL</b>	
039	EROSION CONTROL PLAN BEGIN STA. 3+00 TO END STA. 7+00 BEGIN STA. 12+00 TO END STA. 17+00
040	EROSION CONTROL PLAN BEGIN STA. 22+00 TO END STA. 29+00 BEGIN STA. 34+00 TO END STA. 40+00
<b>EROSION CONTROL DETAILS</b>	
041	EC(1)-16*
042	EC(9-1)-16*
043	EC(9-2)-16*
044	EC(9-3)-16*
045	EPIC*
046	SW3P (1 OF 2)
047	SW3P (2 OF 2)

\*THE STANDARD SHEETS SPECIFICALLY IDENTIFIED ABOVE HAVE BEEN ISSUED BY ME AND ARE APPLICABLE TO THIS PROJECT.

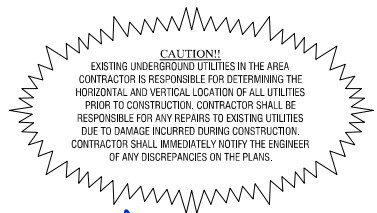

04/05/2024

**Kimley»Horn**

® Texas Registered Engineering Firm F-928



**KELLER FM 1709 LANDSCAPE ENHANCEMENTS GREEN RIBBON PROGRAM PHASE II**  
KELLER, TEXAS

**INDEX OF SHEETS**



04/05/2024

PLOTTED BY: PRESLEY, LAURA  
PLOT DATE: 5/6/2024 2:27 PM  
LOCATION: K:\FTW\_LALP\061097030\_KELLER GREEN RIBBON PH II\DWG\04 CD\SHEET\1\_COVER.DWG  
LAST SAVED: 5/6/2024 2:25 PM

FED.RD.	PROJECT NO.	HIGHWAY NO.	
FM 1709	SEE TITLE SHEET	FM 1709	
STATE	DISTRICT	COUNTY	SHEET NO.
TEXAS	FTW	TARRANT	002
CONTROL	SECTION	JOB	
1603	03	042	

PLOTTED BY: PRESLEY, LAURA  
 PLOT DATE: 5/6/2024 2:27 PM  
 LOCATION: K:\FTW\_LALP\061097030\_KELLER GREEN RIBBON PH II\DWG\04\_CD\SHEET\2 - QUANTITIES.DWG  
 LAST SAVED: 4/5/2024 8:49 PM

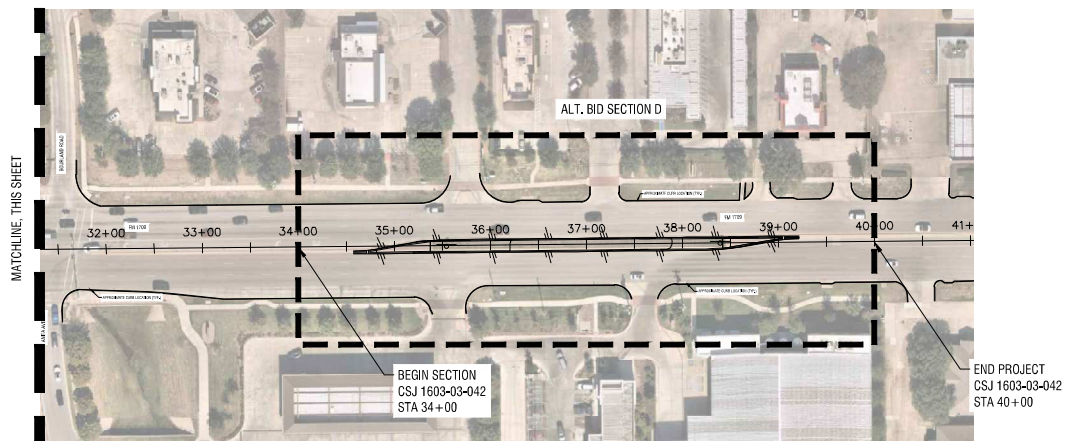
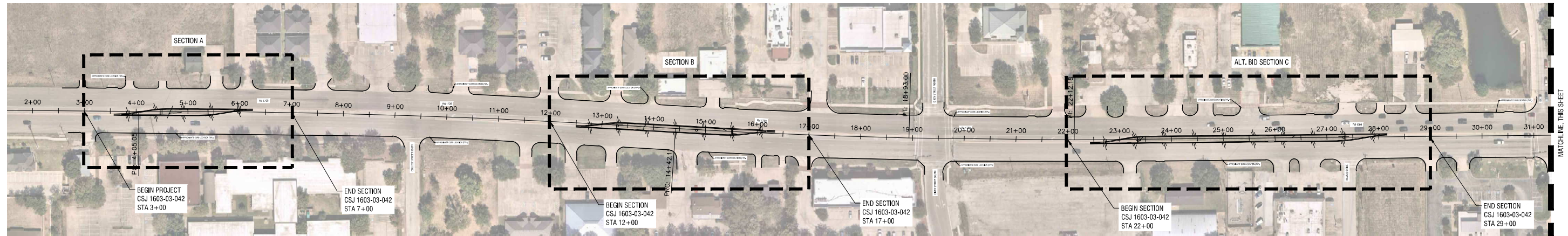

**CAUTION!**  
 EXISTING UNDERGROUND UTILITIES IN THE AREA  
 CONTRACTOR IS RESPONSIBLE FOR DETERMINING THE  
 HORIZONTAL AND VERTICAL LOCATION OF ALL UTILITIES  
 PRIOR TO CONSTRUCTION. CONTRACTOR SHALL BE  
 RESPONSIBLE FOR ANY REPAIRS TO EXISTING UTILITIES  
 DUE TO DAMAGE INCURRED DURING CONSTRUCTION.  
 CONTRACTOR SHALL IMMEDIATELY NOTIFY THE ENGINEER  
 OF ANY DISCREPANCIES ON THE PLANS.



04/05/2024

**Kimley Horn**

® Texas Registered Engineering Firm F-928



**KELLER FM 1709 LANDSCAPE  
 ENHANCEMENTS  
 GREEN RIBBON PROGRAM PHASE II  
 KELLER, TEXAS**

**OVERALL LAYOUT PLAN**

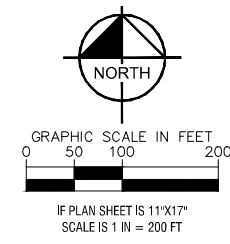

FED.RD.	PROJECT NO.	HIGHWAY NO.
FM 1709	SEE TITLE SHEET	FM 1709
STATE	DISTRICT	COUNTY
TEXAS	FTW	TARRANT
CONTROL	SECTION	JOB
1603	03	042
SHEET NO.		
003		

PLOTTED BY: PRESLEY, LAURA  
 PLOT DATE: 5/6/2024 2:27 PM  
 LOCATION: K:\FTW\_LALP\061097030\_KELLER GREEN RIBBON PH II\DWG\04 CD\SHEET\2 - QUANTITIES.DWG  
 LAST SAVED: 4/5/2024 8:49 PM

BASE BID MATERIAL QUANTITIES																						
		ITEM 100 6002	ITEM 168 6001	ITEM 170 6001	ITEM 192 6004	ITEM 192 6004	ITEM 192 6004	ITEM 192 6004	ITEM 192 6004	ITEM 192 6004	ITEM 192 6004	ITEM 192 6004	ITEM 432 6041	ITEM 192 6025	ITEM 193 6016	ITEM 193 6001	ITEM 193 6007	ITEM 502 6001	ITEM 506 6040	ITEM 506 6043	ITEM 432 6001	ITEM 500 6001
		PREPARING ROW	VEGETATIVE WATERING	IRRIGATION SYSTEM	PLANT MATERIAL (5 - GAL) (SHRUB) (COMPACT TEXAS SAGE)	PLANT MATERIAL (5 - GAL) (SHRUB) (RED YUCCA)	PLANT MATERIAL (5 - GAL) (SHRUB) (LEMON-LIME HEAVENLY BAMBOO)	PLANT MATERIAL (5 - GAL) (SHRUB) (ORANGE ROCKET BARBERRY)	PLANT MATERIAL (5 - GAL) (SHRUB) (COLOR GUARD YUCCA)	PLANT MATERIAL (5 - GAL) (SHRUB) (SPINELESS PRICKLYPEAR)	PLANT MATERIAL (5 - GAL) (SHRUB) (PINK MUHLY)	PLANT MATERIAL (5 - GAL) (SHRUB) (MEXICAN FEATHER GRASS)	RIPRAP (SPECIAL)(RIVER ROCK) (4") (ARIZONA)	PLANT MATERIAL (45 - GAL) (TREE)	PLANT BED PREP	PLANT MAINTENANCE	SYSTEM OPERATION & MAINTENANCE	BARRICADES SIGNS & TRAFFIC HANDLING	INSTALL BIO LOGS EROSION CONTROL (8")	REMOVE BIO LOGS EROSION CONTROL (8")	RIP RAP (CONC)(4 IN)	MOBILIZATION
SECTION #	STATION #	(STA)	(MG)	(LS)	(EA)	(EA)	(EA)	(EA)	(EA)	(EA)	(EA)	(EA)	(CY)	(EA)	(SY)	(MO)	(MO)	(MO)	(LF)	(LF)	(CY)	(LS)
A	BEGIN STA 3+00 TO END STA 7+00	4	0.7		5	11	6	13	6	5	8	14	9	2	79				211	211	4	
B	BEGIN STA 12+00 TO END STA 17+00	5	1.7		6	18	10	22	13	7	30	39	22	5	195				475	475	8	
	<b>TOTALS</b>	9	2.4	1	11	29	16	35	19	12	38	53	31	7	274	12	12	5	686	686	12	1

ALTERNATE BID MATERIAL QUANTITIES																						
		ITEM 100 6002	ITEM 168 6001	ITEM 170 6001	ITEM 192 6004	ITEM 192 6004	ITEM 192 6004	ITEM 192 6004	ITEM 192 6004	ITEM 192 6004	ITEM 192 6004	ITEM 192 6004	ITEM 432 6041	ITEM 192 6025	ITEM 193 6016	ITEM 193 6001	ITEM 193 6007	ITEM 502 6001	ITEM 506 6040	ITEM 506 6043	ITEM 432 6001	ITEM 500 6001
		PREPARING ROW	VEGETATIVE WATERING	IRRIGATION SYSTEM	PLANT MATERIAL (5 - GAL) (SHRUB) (COMPACT TEXAS SAGE)	PLANT MATERIAL (5 - GAL) (SHRUB) (RED YUCCA)	PLANT MATERIAL (5 - GAL) (SHRUB) (LEMON-LIME HEAVENLY BAMBOO)	PLANT MATERIAL (5 - GAL) (SHRUB) (ORANGE ROCKET BARBERRY)	PLANT MATERIAL (5 - GAL) (SHRUB) (COLOR GUARD YUCCA)	PLANT MATERIAL (5 - GAL) (SHRUB) (SPINELESS PRICKLYPEAR)	PLANT MATERIAL (5 - GAL) (SHRUB) (PINK MUHLY)	PLANT MATERIAL (5 - GAL) (SHRUB) (MEXICAN FEATHER GRASS)	RIPRAP (SPECIAL)(RIVER ROCK) (4") (ARIZONA)	PLANT MATERIAL (45 - GAL) (TREE)	PLANT BED PREP	PLANT MAINTENANCE	SYSTEM OPERATION & MAINTENANCE	BARRICADES SIGNS & TRAFFIC HANDLING	INSTALL BIO LOGS EROSION CONTROL (8")	REMOVE BIO LOGS EROSION CONTROL (8")	RIP RAP (CONC)(4 IN)	MOBILIZATION
SECTION #	STATION #	(STA)	(MG)	(LS)	(EA)	(EA)	(EA)	(EA)	(EA)	(EA)	(EA)	(EA)	(CY)	(EA)	(SY)	(MO)	(MO)	(MO)	(LF)	(LF)	(CY)	(LS)
C	BEGIN STA 22+00 TO END STA 29+00	7	3		11	37	8	36	22	14	40	60	38	6	339				828	828	15	
D	BEGIN STA 34+00 TO END STA 40+00	6	2.3		13	34	6	25	12	8	42	30	29	6	260				635	635	11	
	<b>TOTALS</b>	13	5.3	1	24	71	14	61	34	22	82	90	67	12	599	12	12	5	1,463	1,463	26	1

**CAUTION!**  
 EXISTING UNDERGROUND UTILITIES IN THE AREA CONTRACTOR IS RESPONSIBLE FOR DETERMINING THE HORIZONTAL AND VERTICAL LOCATION OF ALL UTILITIES PRIOR TO CONSTRUCTION. CONTRACTOR SHALL BE RESPONSIBLE FOR ANY REPAIRS TO EXISTING UTILITIES DUE TO DAMAGE INCURRED DURING CONSTRUCTION. CONTRACTOR SHALL IMMEDIATELY NOTIFY THE ENGINEER OF ANY DISCREPANCIES ON THE PLANS.



04/05/2024

**Kimley Horn**

® Texas Registered Engineering Firm F-928



**KELLER FM 1709 LANDSCAPE ENHANCEMENTS GREEN RIBBON PROGRAM PHASE II**  
 KELLER, TEXAS

**SUMMARY OF QUANTITIES**

FED.RD.	PROJECT NO.	HIGHWAY NO.
FM 1709	SEE TITLE SHEET	FM 1709
STATE	DISTRICT	COUNTY
TEXAS	FTW	TARRANT
CONTROL	SECTION	JOB
1603	03	042
SHEET NO.		004

Control: 1603-03-042

County: Tarrant

Highway: FM 1709

Specification Data

**Basis of Estimate**

Item Description	Rate	Unit
168 Vegetative Watering	169,400 gal./acre	1,000 gal.

**Special Notes**

Contractor questions on this project are to be addressed to the following individual(s):

Area Engineer's Email: [troy.davis@txdot.gov](mailto:troy.davis@txdot.gov)

Assistant Area Engineer's Email: [alfred.luera@txdot.gov](mailto:alfred.luera@txdot.gov)

Design Manager's Email: [sam.yacoub@txdot.gov](mailto:sam.yacoub@txdot.gov)

Submit any questions about this project via the Letting Pre-Bid Q&A web page, located at: <https://tableau.txdot.gov/views/ProjectInformationDashboard/NoticetoContractors>

The Letting Pre-Bid Q&A web page for each project can be accessed by scrolling or filtering the dashboard using the controls on the left side to navigate to the project. Hover over the blue hyperlink of the project to view the Q&A and click on the link in the window that pops up.

Electronic files containing project related design information will continue to be placed in the following FTP site:

[Index of /pub/txdot-info/Pre-Letting Responses \(state.tx.us\)](#)

The site is organized by District, Project Type (Construction or Maintenance), Letting Date, CCSJ/Project Name.

Check this site for new information. Notices of new postings will not be sent out by the Engineer.

All files in the FTP site are subject to the License Agreement shown on the FTP site.

The data located in these files is for non-construction purposes.

Access is read-only.

Single lane closures, except as otherwise shown in the plans, will be restricted to off-peak hours as defined in the following table:

General Notes

Control: 1603-03-042

County: Tarrant

Highway: FM 1709

Peak Hours		Off-Peak Hours	
6 to 9 AM Monday through Friday	3 to 7 PM Monday through Friday	9 AM to 3 PM and 7 PM to 6 AM Monday through Friday	All day Saturday and Sunday

Work that requires closure of multiple travel lanes in the same direction, except as otherwise shown in the plans, are restricted to night hours between 9 PM and 6 AM.

Existing storm sewers and utilities are shown from the best available information. Verify the location of all underground facilities prior to starting work.

For dimensions of right-of-way not shown on the plans, see right-of-way map on file at the TxDOT District Office.

**Modifications to Lane Closure / Work Restrictions:**

Submit a request in writing for approval by the Engineer a minimum of 10 days in advance of implementing a change to lane closure restrictions.

When deemed necessary, the Engineer will lengthen, shorten, or otherwise modify lane closure restrictions as traffic conditions warrant.

When deemed necessary, the Engineer will modify the list of major events when new events develop, existing events are rescheduled, or when warranted.

Special Events/ Special Situations will be handled on a case-by-case basis. No work restricting lane closures is allowed from 3 PM a day before to 9 AM the day after the Special Event or Special Situation.

Do not discolor or damage existing curb and curb and gutter during construction operations. In the event of discoloration or damage, clean or repair as directed.

Provide temporary drain openings at all low points or other drainage structures, as required, at the Contractor's expense.

Remove any obstructions to existing drainage due to the contractor's operations, as required, at the Contractor's expense.

General Notes

Sheet 5

**Control:** 1603-03-042

**County:** Tarrant

**Highway:** FM 1709

**Item 4 – Scope of Work**

Reimbursement for project overhead will not be considered until project completion has extended beyond the original Contract Time.

**Item 5. Control of the Work**

When shop drawings, shop details, erection drawings, working drawings, forming plans, or other drawings are required, prepare and submit drawings on sheets 8-1/2 by 11 inches, 17 by 22 inches, or full size drawings reduced to half scale if completely legible. If, in the opinion of the Engineer, the drawings are not completely legible, prepare and submit on sheets 22 by 34 inches, with a 1-1/2 inch left margin, and 1/2 inch top, right, and bottom margins.

Submit all sheets with a title in the lower right hand corner. The title must include the sheet index data shown on the lower right corner of the project plans, name of the structure or element or stream, sheet numbering for the shop drawings, name of the fabricator and the name of the Contractor.

Standard Operating Procedure for Alternate Precast Proposal Submission” found online at <https://www.txdot.gov/inside-txdot/forms-publications/consultants-contractors/publications/bridge.html#design>. Acceptance or denial of an alternate is at the sole discretion of the Engineer. Impacts to the project schedule and any additional costs resulting from the use of alternates are the sole responsibility of the Contractor.

**Item 6. Control of Materials**

To comply with the latest provisions of Build America, Buy America Act (BABA Act) of the Bipartisan Infrastructure Law, the contractor must submit an original of the TxDOT Construction Material Buy America Certification Form for all items classified as construction materials. This form is not required for materials classified as a manufactured product.

Refer to the Buy America Material Classification Sheet for clarification on material categorization.

The Buy America Material Classification Sheet is located at the below link.

<https://www.txdot.gov/business/resources/materials/buy-america-material-classification-sheet.html> for clarification on material categorization.

**Item 7. Legal Relations and Responsibilities**

The total area disturbed for this project is .22 acres. The disturbed area in this project, all project locations in the Contract, and the Contractor project specific locations (PSLs), within 1 mile of

**Control:** 1603-03-042

**County:** Tarrant

**Highway:** FM 1709

the project limits, for the Contract will further establish the authorization requirements for storm water discharges. The Department will obtain an authorization to discharge storm water from the Texas Commission on Environmental Quality (TCEQ) for the construction activities shown on the plans. The Contractor is to obtain required authorization from the TCEQ for Contractor PSLs for construction support activities on or off the right of way. When the total area disturbed in the Contract and PSLs within 1 mile of the project limits exceeds 5 acres, provide a copy of the Contractor NOI for PSLs on the right of way to the Engineer and to the local government that operates a separate storm sewer system.

When a bridge deck is milled, seal coated and overlaid, remove excess material. Do not just broom to the sides of the bridge, under guardrail, etc. Cover or protect all sealed expansion joints and rails on bridges and all railroad tracks encountered as approved. Clean and repair all of these features if they weren't properly protected at contractor's expense. This work is subsidiary work to applicable bid items.

Prevention of Migratory Bird Nesting

It is anticipated that migratory birds, a protected group of species, may try to nest on bridges, culverts, vegetation, or gravel substrate, at any time of the year. The preferred nesting season for migratory birds is from February 15 through October 1. When practicable, schedule construction operations outside of the preferred nesting season. Otherwise, avoid nests containing migratory birds and perform no work in the nesting areas until the young birds have fledged.

The following Holiday/Event lane closure restriction requirements apply to this project: No work that restricts or interferes with traffic shall be allowed between 3 PM on the day preceding a Holiday or Event and 9 AM on the day after the Holiday or Event.

Holiday Lane Closure Restrictions	
<b>New Year's Eve and New Year's Day</b> (December 31 through January 1)	3 PM December 30 through 9 AM January 2
<b>Easter Holiday Weekend</b> (Friday through Sunday)	3PM Thursday through 9 AM Monday
<b>Memorial Day Weekend</b> (Friday through Monday)	3 PM Thursday through 9 AM Tuesday
<b>Independence Day</b> (July 3 through July 5)	3 PM July 2 through 9 AM July 6
<b>Labor Day Weekend</b> (Friday through Monday)	3 PM Thursday through 9 AM Tuesday
<b>Thanksgiving Holiday</b> (Wednesday through Sunday)	3 PM Tuesday through 9 AM Monday

Control: 1603-03-042

County: Tarrant

Highway: FM 1709

Christmas Holiday (December 23 through December 26)	3 PM December 22 through 9 AM December 27
---	---

Plan work schedules around the appropriate dates above to ensure productive work is performed without lane closures.

Event Lane Closure Restrictions			
3 PM the day before Event to 9 AM the day after the Event			
NASCAR Races at Texas Motor Speedway (generally 3 events):	NASCAR Nationwide and Sprint Cup Series (Held in late March/early April)	NASCAR Nationwide and Sprint Cup Series (Held in Late October/early November)	Indy Series Racing and NASCAR Truck Series (Held in June)
Within one mile radius of major retail traffic generators i.e. malls (Thanksgiving Day through January 2)			
Fort Worth Stock Show and Rodeo			
Arlington Entertainment District			
Grapevine Festivals (Including but not limited to: Carol of Lights, Black Friday Weekend, Christmas Parade, and weekends during Christmas Capital of Texas)			
MayFest			
Weatherford Peach Festival			

**Item 8. Prosecution and Progress**

Working days will be computed and charged in accordance with Section 8.3.1.1, 'Five-Day Workweek.'

Number of days for project acceptance is 107 contract working days.

The time charges for the project will begin upon day one of mobilization.  
The time charges for the project will end upon substantial completion.

Progress schedule to be provided by contractor and in CPM format. Coordinate with managing area office on progress schedule.

Control: 1603-03-042

County: Tarrant

Highway: FM 1709

**Item 100. Preparing Right of Way**

Measurement for this item will be along the centerline of the project with the limits of measurements as shown on the plans.

**Item 164. Seeding for Erosion Control**

Apply seeding required between December 1 and January 31 using seed types and mixtures as shown in Item 164.2.1, Table 3. If, in the opinion of the Engineer, this does not provide an effective vegetative cover, apply "straw or hay mulch" as specified in Article 164.3.2. "Straw or Hay Mulch Seeding" as soon as possible. After February 1, apply warm season seeding in order to establish a permanent protective vegetative cover.

**Item 168. Vegetative Watering**

Furnish and install an approved rain gauge at the project site, as directed. Furnishing and installation of the rain gauge will not be paid for directly but will be subsidiary to Item 168.

Apply vegetative watering for an establishment period of thirteen weeks following application of seed or installation of sod, at a rate of 1/2 inch of water depth per week (approximately 13,030 gallons per acre). During the first four weeks after seeding, apply water twice per week, on non-consecutive days, each at half the weekly application rate. For the remainder of the establishment period, apply vegetative watering once per week during the months of January through June or September through December, at the weekly application rate; apply watering twice per week, on non-consecutive days during the months of July and August, each at one-half the weekly application rate.

Average weekly rainfall rates for the District are:

January—0.39"	April—0.86"	July—0.48"	October—0.68"
February—0.46"	May—1.00"	August—0.47"	November—0.46"
March—0.48"	June—0.63"	September—0.74"	December—0.37"

**Item 192. Planting**

No planting shall occur between June 1st and September 15th without written approval from the Engineer.

Perform soil percolation test at least 24 hours prior to planting trees in plant pits. Excavate plant pit and fill entirely with water. Inspect planting pit within 24 hours to verify water has percolated into surrounding soil. In the event the water is present after 24 hours, contact Engineer before continuing tree planting in pits.

**Control:** 1603-03-042

**County:** Tarrant

**Highway:** FM 1709

Prior to installing any plant material, ensure the irrigation system (if included in project) is pressurized up to the valves.

Begin the 90-day maintenance period only after all live plant material and functional irrigation systems have been installed as shown on plans. It is understood that the contractor will provide 3" of bark mulch for the 45-gallon plant material subsidiary to item 192-6025. All other bark mulch areas are paid for under pay item 192-6004.

Per special provision 192-001 plant material requiring replacement will be at the cost of the contractor.

**Item 193. Landscape Establishment**

The Contractor shall maintain the project area and be responsible for the adequate irrigation of the trees and planting beds during the 12-month establishment period.

Begin the additional establishment period covered under this item only after all maintenance activities have been completed under items 170 and 192 and after all plant material and irrigation systems have been installed as shown on plans. The Engineer may authorize in writing beginning the 12-month establishment period at individual locations provided the installations are complete at those locations.

Replace dead or dying plant material within 10 days of notification by the Engineer unless otherwise indicated in the notification. Plant material replacement will be subsidiary to this item unless determined otherwise by the Engineer.

Contractor will continue to pay for water used through the irrigation meter during the maintenance period under this item. Transfer the meter to the City at the end of the project.

**Item 432. Riprap**

Provide weep holes as directed.

The quantities for riprap at the location indicated may be varied to the extent necessary to ensure proper functioning for the purpose intended.

All concrete riprap will be 4" (.33') in thickness, unless otherwise shown on the plans, and must be reinforced.

Provide a toe wall at all exposed edges of all protection stone riprap, unless otherwise directed.

**Item 502. Barricades, Signs, and Traffic Handling**

General Notes

**Control:** 1603-03-042

**County:** Tarrant

**Highway:** FM 1709

The contractor force account 'safety contingency' that has been established for this project is intended to be utilized for work zone enhancements to improve the effectiveness of the traffic control plan that could typically not be foreseen in the project planning and design stage. These enhancements will be mutually agreed upon by the Engineer and the Contractor's responsible person based on weekly or more frequent traffic management reviews on the project. The Engineer may choose to use existing bid items if it does not slow the implementation of enhancement.

Permanent signs may be installed when construction in an area is complete and they will not conflict with the traffic control plan for the remainder of the job.

Existing signs are to remain as long as they do not interfere with construction and they do not conflict with the traffic control plan.

Any sign not detailed in the plans but called for in the layout will be as shown in the current "Standard Highway Sign Designs for Texas".

When traffic is obstructed, arrange warning devices in accordance with the latest edition of the "Texas Manual on Uniform Traffic Control Devices".

Cover or remove any work zone signs when work or condition referenced is not occurring.

Do not place barricades, signs, or any other traffic control devices where they interfere with sight distance at driveways or side streets. Provide access to all driveways during all phases of construction unless otherwise noted in the plans or as directed.

**Item 506. Temporary Erosion, Sedimentation, and Environmental Controls**

Remove accumulated sediment or replace SW3P controls when the capacity has been reduced by 50% or when the depth of sediment at the control structure exceeds one foot.

General Notes

Sheet 5C





CONTROLLING PROJECT ID 1603-03-042

DISTRICT Fort Worth  
HIGHWAY FM 1709

COUNTY Tarrant

# Estimate & Quantity Sheet

CONTROL SECTION JOB				1603-03-042		TOTAL EST.	TOTAL FINAL
PROJECT ID				A00205773			
COUNTY				Tarrant			
HIGHWAY				FM 1709			
ALT	BID CODE	DESCRIPTION	UNIT	EST.	FINAL		
	100-6002	PREPARING ROW	STA	9.000		9.000	
	168-6001	VEGETATIVE WATERING	MG	2.400		2.400	
	170-6001	IRRIGATION SYSTEM	LS	1.000		1.000	
	192-6004	PLANT MATERIAL (5-GAL)	EA	213.000		213.000	
	192-6016	PLANT BED PREPARATION	SY	274.000		274.000	
	192-6025	PLANT MATERIAL (45 GAL) (TREE)	EA	7.000		7.000	
	193-6001	PLANT MAINTENANCE	MO	12.000		12.000	
	193-6007	IRRIGATION SYSTEM OPER AND MAINT	MO	12.000		12.000	
	432-6001	RIPRAP (CONC)(4 IN)	CY	12.000		12.000	
	432-6041	RIPRAP (SPECIAL)	CY	31.000		31.000	
	500-6001	MOBILIZATION	LS	1.000		1.000	
	502-6001	BARRICADES, SIGNS AND TRAFFIC HANDLING	MO	5.000		5.000	
	506-6040	BIODEG EROSN CONT LOGS (INSTL) (8")	LF	686.000		686.000	
	506-6043	BIODEG EROSN CONT LOGS (REMOVE)	LF	686.000		686.000	
	618-6034	CONDT (PVC) (SCH 40) (4") (BORE)	LF	84.000		84.000	
	18	EROSION CONTROL MAINTENANCE: CONTRACTOR FORCE ACCOUNT WORK (PART)	LS	1.000		1.000	
		SAFETY CONTINGENCY: CONTRACTOR FORCE ACCOUNT WORK (PARTICIPATING)	LS	1.000		1.000	

PLOTTED BY: PRESLEY, LAURA  
 PLOT DATE: 5/6/2024 2:27 PM  
 LOCATION: K:\FTW\_LALP\061097030\_KELLER GREEN RIBBON PH II\DWG\04 CD\SHEET\3 - EXISTING CONDITIONS.DWG  
 LAST SAVED: 4/5/2024 8:56 PM

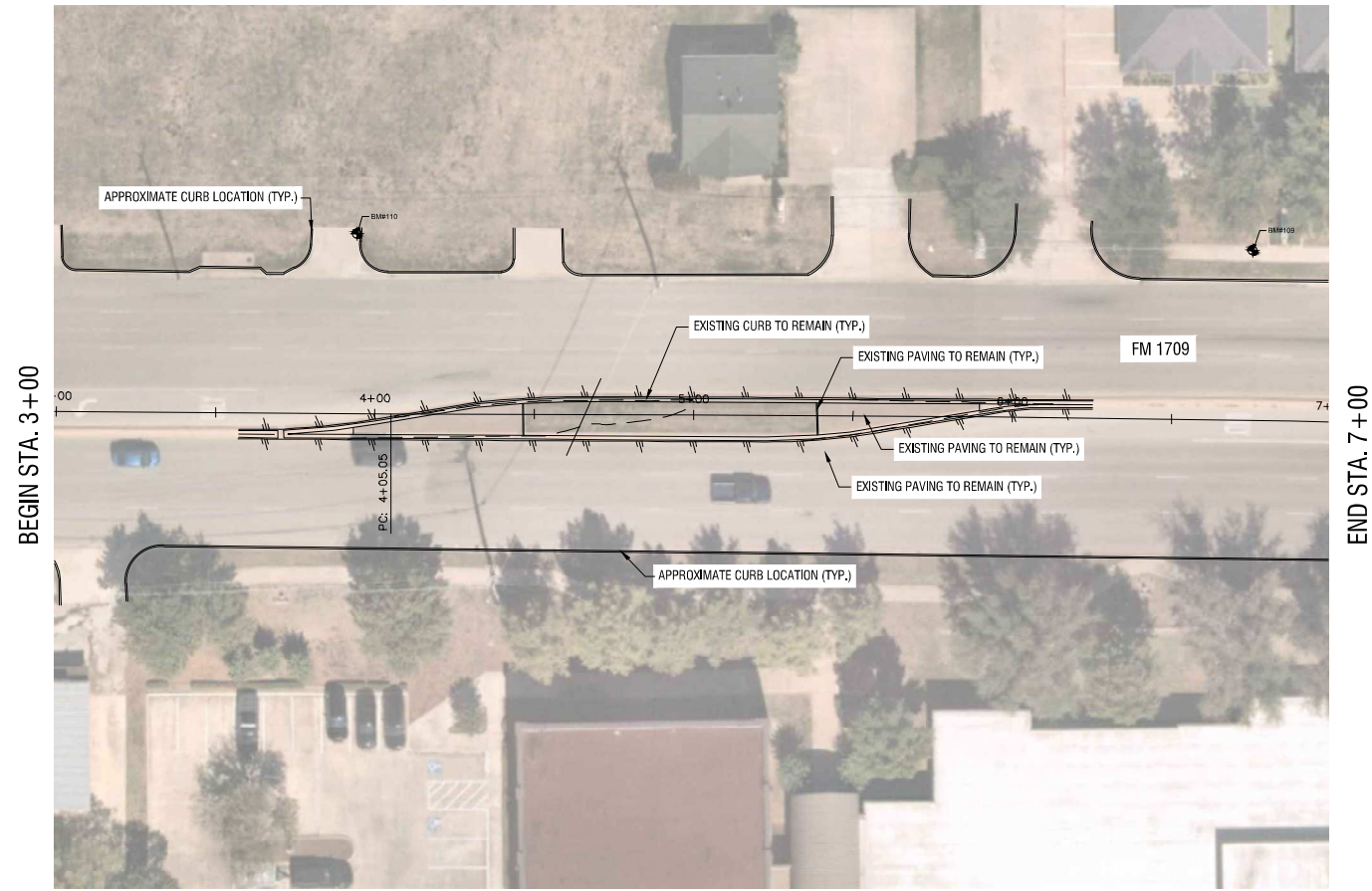

BEGIN STA. 3+00

END STA. 7+00

**A** BEGIN STA. 3+00 TO END STA. 7+00  
 PLAN

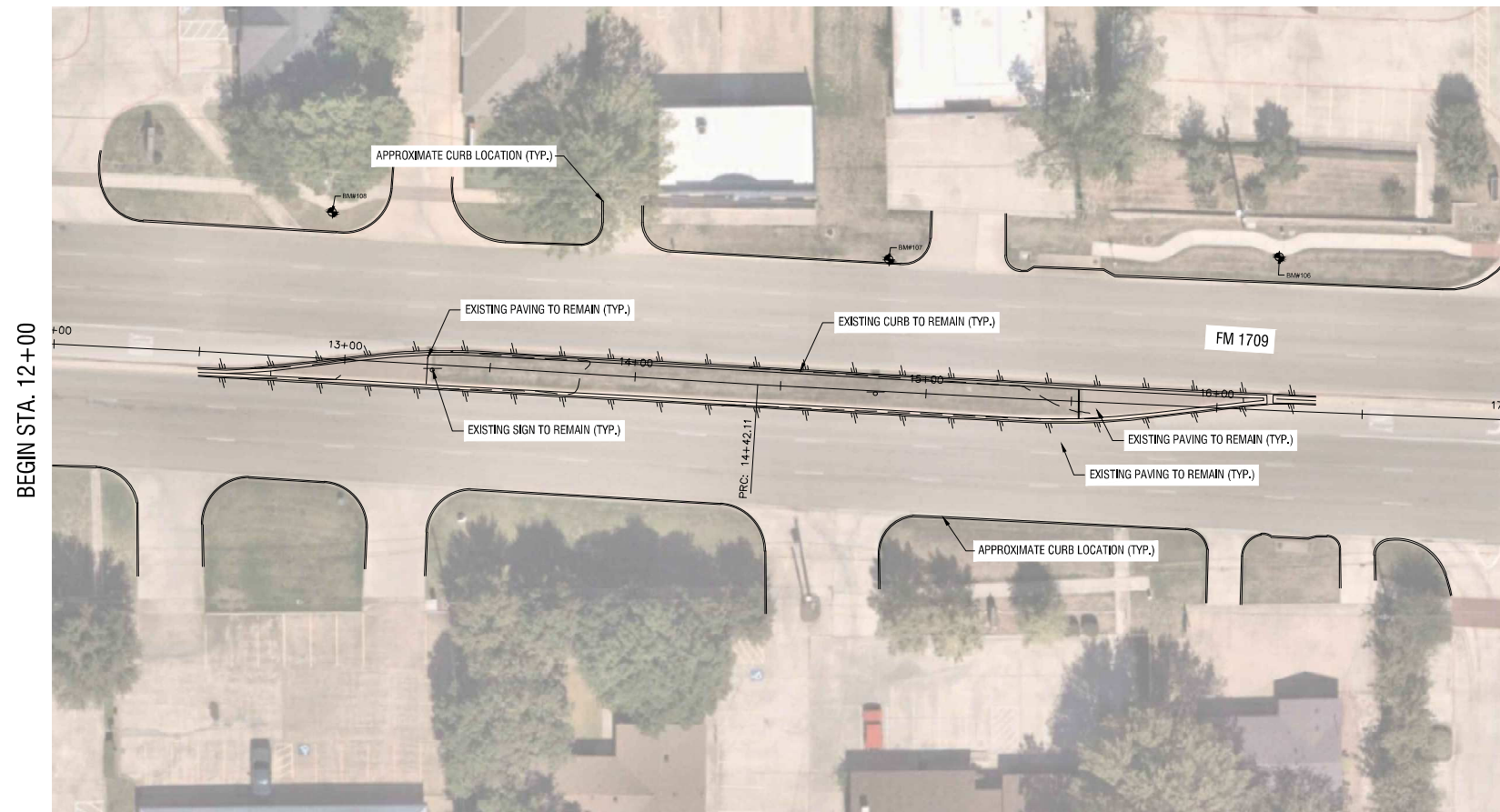

BEGIN STA. 12+00

END STA. 17+00

**B** BEGIN STA. 12+00 TO END STA. 17+00  
 PLAN

**CAUTION!**  
 EXISTING UNDERGROUND UTILITIES IN THE AREA  
 CONTRACTOR IS RESPONSIBLE FOR DETERMINING THE  
 HORIZONTAL AND VERTICAL LOCATION OF ALL UTILITIES  
 PRIOR TO CONSTRUCTION. CONTRACTOR SHALL BE  
 RESPONSIBLE FOR ANY REPAIRS TO EXISTING UTILITIES  
 DUE TO DAMAGE INCURRED DURING CONSTRUCTION.  
 CONTRACTOR SHALL IMMEDIATELY NOTIFY THE ENGINEER  
 OF ANY DISCREPANCIES ON THE PLANS.



04/05/2024

**Kimley Horn**

® Texas Registered Engineering Firm F-928

Texas Department of Transportation  
 © 2024

**KELLER FM 1709 LANDSCAPE  
 ENHANCEMENTS  
 GREEN RIBBON PROGRAM PHASE II  
 KELLER, TEXAS**

**EXISTING CONDITIONS  
 STA. 3+00 TO STA. 7+00  
 STA. 12+00 TO STA. 17+00**

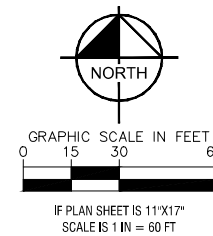

NOTE: EXISTING SIGN BASES TO BE ADJUSTED PER NEW FINISHED GRADE OF MATERIAL WITHIN MEDIAN AND PER TXDOT SIGNAGE STANDARDS. ITEM TO BE INCLUDING IN PREPARED ROW.

FED.RD.	PROJECT NO.	HIGHWAY NO.
FM 1709	SEE TITLE SHEET	FM 1709
STATE	DISTRICT	COUNTY
TEXAS	FTW	TARRANT
CONTROL	SECTION	JOB
1603	03	042
SHEET NO.		
007		

PLOTTED BY: PRESLEY, LAURA  
 PLOT DATE: 5/6/2024 2:28 PM  
 LOCATION: K:\FTW\_LALP\061097030\_KELLER GREEN RIBBON PH II\DWG\04 CD\SHEET\3 - EXISTING CONDITIONS.DWG  
 LAST SAVED: 4/5/2024 8:56 PM

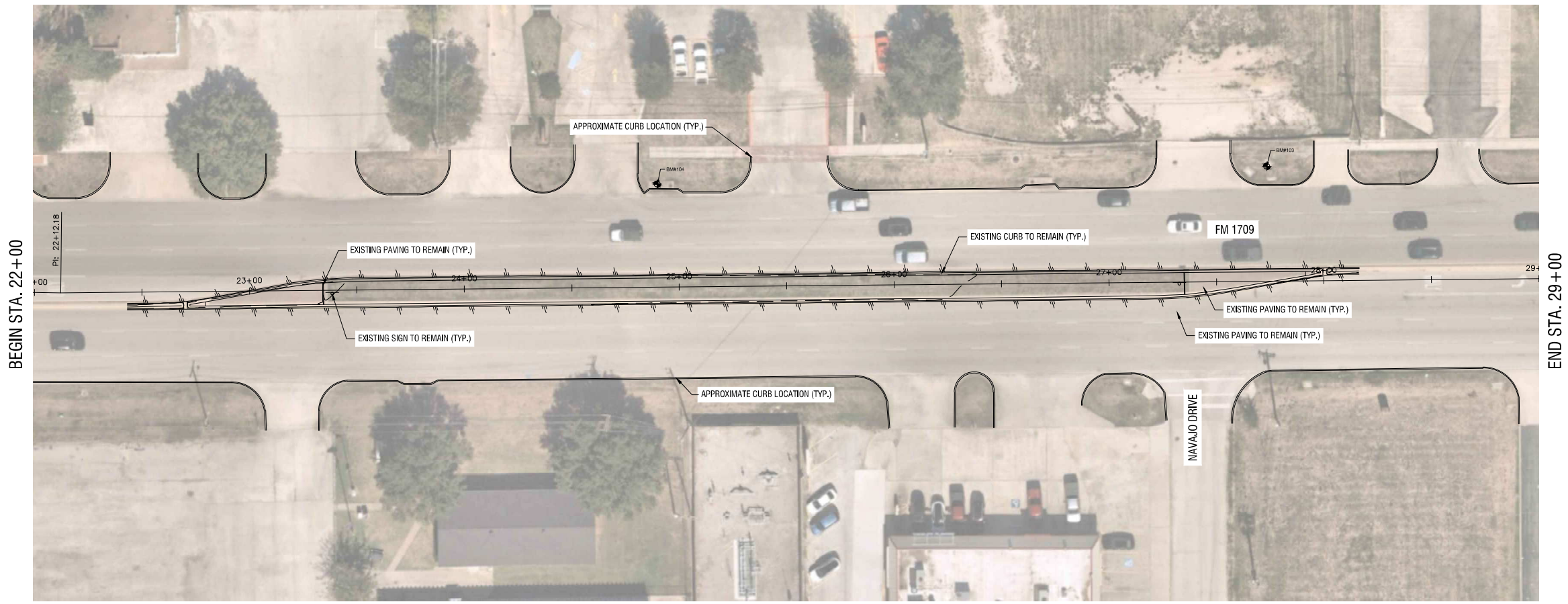

BEGIN STA. 22+00

END STA. 29+00

**C** ALTERNATE BID: BEGIN STA. 22+00 TO END STA. 29+00  
 PLAN



BEGIN STA. 34+00

END STA. 40+00

**D** ALTERNATE BID: BEGIN STA. 34+00 TO END STA. 40+00  
 PLAN

NOTE: EXISTING SIGN BASES TO BE ADJUSTED PER NEW FINISHED GRADE OF MATERIAL WITHIN MEDIAN AND PER TXDOT SIGNAGE STANDARDS. ITEM TO BE INCLUDING IN PREPARED ROW.

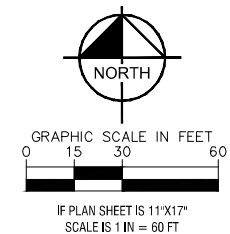

**CAUTION!**  
 EXISTING UNDERGROUND UTILITIES IN THE AREA CONTRACTOR IS RESPONSIBLE FOR DETERMINING THE HORIZONTAL AND VERTICAL LOCATION OF ALL UTILITIES PRIOR TO CONSTRUCTION. CONTRACTOR SHALL BE RESPONSIBLE FOR ANY REPAIRS TO EXISTING UTILITIES DUE TO DAMAGE INCURRED DURING CONSTRUCTION. CONTRACTOR SHALL IMMEDIATELY NOTIFY THE ENGINEER OF ANY DISCREPANCIES ON THE PLANS.



04/05/2024



**KELLER FM 1709 LANDSCAPE ENHANCEMENTS GREEN RIBBON PROGRAM PHASE II**  
 KELLER, TEXAS

**EXISTING CONDITIONS**  
 STA. 22+00 TO STA. 29+00  
 STA. 34+00 TO STA. 40+00

FED.RD.	PROJECT NO.	HIGHWAY NO.
FM 1709	SEE TITLE SHEET	FM 1709
STATE	DISTRICT	COUNTY
TEXAS	FTW	TARRANT
CONTROL	SECTION	JOB
1603	03	042
		SHEET NO.
		008

DISCLAIMER: The use of this standard is governed by the "Texas Engineering Practice Act". No warranty of any kind is made by TxDOT for any purpose whatsoever. TxDOT assumes no responsibility for the conversion of this standard to other formats or for incorrect results or damages resulting from its use.

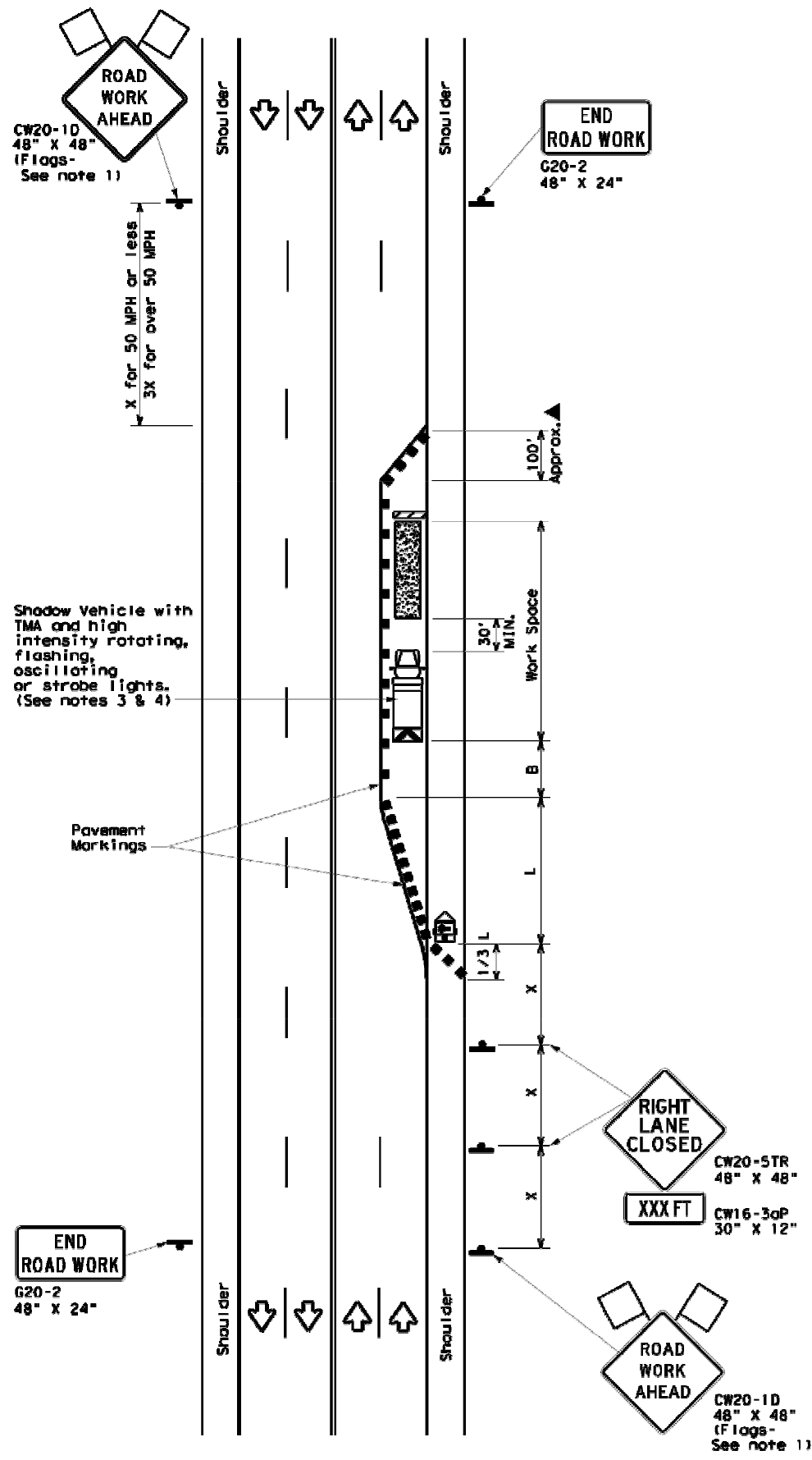

**TCP (2-5a)**  
**ONE LANE CLOSED**

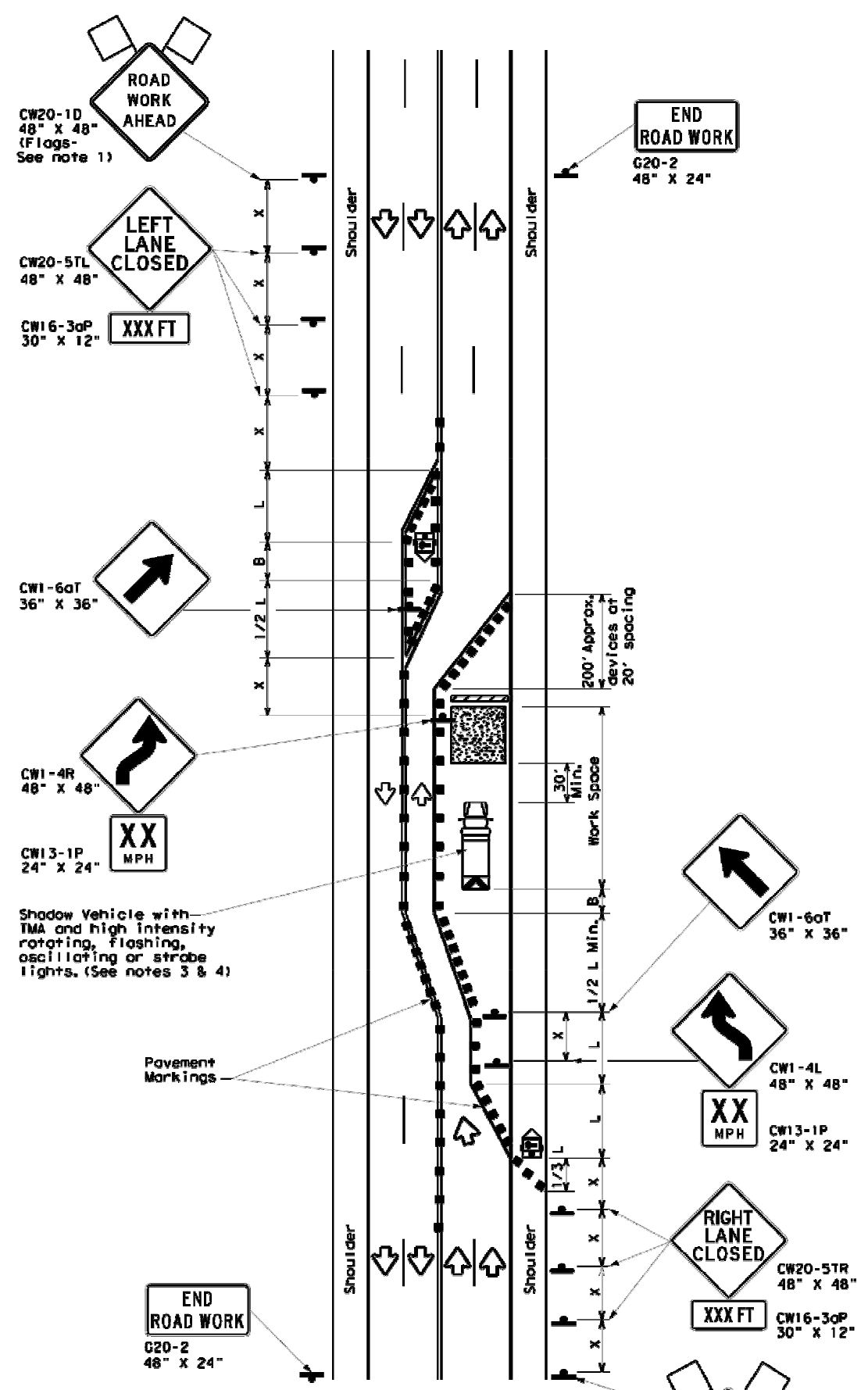

**TCP (2-5b)**  
**TWO LANES CLOSED**

**LEGEND**

	Type 3 Barricade		Channelizing Devices
	Heavy Work Vehicle		Truck Mounted Attenuator (TMA)
	Trailer Mounted Flashing Arrow Board		Portable Changeable Message Sign (PCMS)
	Sign		Traffic Flow
	Flag		Flagger

Posted Speed #	Formula	Minimum Desirable Taper Lengths * #			Suggested Maximum Spacing of Channelizing Devices		Minimum Sign Spacing "X" Distance	Suggested Longitudinal Buffer Space "B"
		10' Offset	11' Offset	12' Offset	On a Taper	On a Tangent		
30	L = WS <sup>2</sup> / 60	150'	165'	180'	30'	60'	120'	90'
35		205'	225'	245'	35'	70'	160'	120'
40		265'	295'	320'	40'	80'	240'	155'
45	L = WS	450'	495'	540'	45'	90'	320'	195'
50		500'	550'	600'	50'	100'	400'	240'
55		550'	605'	660'	55'	110'	500'	295'
60		600'	660'	720'	60'	120'	600'	350'
65		650'	715'	780'	65'	130'	700'	410'
70	700'	770'	840'	70'	140'	800'	475'	
75	750'	825'	900'	75'	150'	900'	540'	

\* Conventional Roads Only  
\*\* Taper lengths have been rounded off.  
L- Length of Taper (FT) W- Width of Offset (FT) S- Posted Speed (MPH)

**TYPICAL USAGE**

MOBILE	SHORT DURATION	SHORT TERM STATIONARY	INTERMEDIATE TERM STATIONARY	LONG TERM STATIONARY
			✓	✓

- GENERAL NOTES**
- Flags attached to signs where shown, are REQUIRED.
  - All traffic control devices illustrated are REQUIRED, except those denoted with the triangle symbol may be omitted when stated elsewhere in the plans, or for routine maintenance work, when approved by the Engineer.
  - A Shadow Vehicle with a TMA should be used anytime it can be positioned 30 to 100 feet in advance of the area of crew exposure without adversely affecting the performance or quality of the work. If workers are no longer present but road or work conditions require the traffic control to remain in place, Type 3 Barricades or other channelizing devices may be substituted for the Shadow Vehicle and TMA.
  - Additional Shadow Vehicles with TMAs may be positioned in each closed lane, on the shoulder or off the paved surface, next to those shown in order to protect a wider work space.
  - The downstream taper is optional. When used, it should be 100 feet approximately per lane, with channelizing devices spaced at 20 feet.

- TCP (2-5a)**
- If this TCP is used for a left lane closure, CW20-5TL "LEFT LANE CLOSED" signs shall be used and channelizing devices shall be placed on the centerline to protect the work space from opposing traffic, with the arrow board placed in the closed lane near the end of the merging taper.
- TCP (2-5b)**
- Conflicting pavement markings shall be removed for long-term projects.

Texas Department of Transportation Traffic Operations Division Standard

**TRAFFIC CONTROL PLAN**  
**LONG TERM LANE CLOSURES**  
**MULTILANE CONVENTIONAL RDS.**

**TCP (2-5) - 18**

FILE: top2-5-18.dgn	REV: TxDOT	REV: TxDOT	REV: TxDOT	REV: TxDOT
© TxDOT December 1985	DATE	SECT	JOB	HIGHWAY
8-95 2-12	1603	03	042	FM 1709
1-97 3-03	DIST	COUNTY		SHEET NO.
4-98 2-18	FTW	TARRANT		009

DATE: FILE:

DISCLAIMER: The use of this standard is governed by the "Texas Engineering Practice Act". No warranty of any kind is made by TxDOT for any purpose whatsoever. TxDOT assumes no responsibility for the conversion of this standard to other formats or for incorrect results or damages resulting from its use.

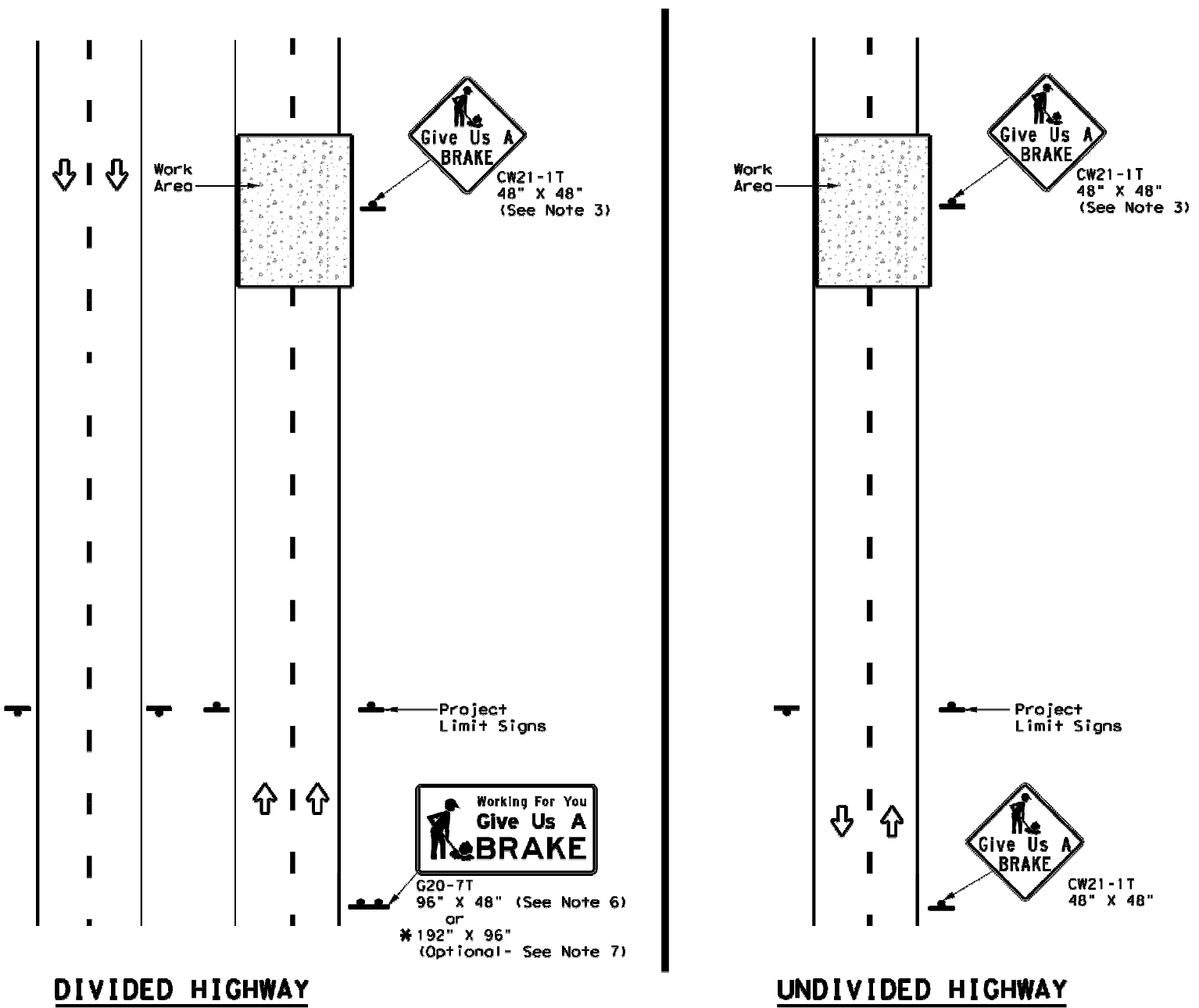

**DIVIDED HIGHWAY**

**UNDIVIDED HIGHWAY**

SIGNS ARE SHOWN FOR ONE DIRECTION OF TRAVEL

\* When the optional larger WORKING FOR YOU GIVE US A BRAKE (G20-7T) 192" x 96" sign is required, the locations shall be noted elsewhere in the plans.

DATE: FILE:

**SUMMARY OF LARGE SIGNS**

BACKGROUND COLOR	SIGN DESIGNATION	SIGN	SIGN DIMENSIONS	REFLECTIVE SHEETING	SQ FT	GALVANIZED STRUCTURAL STEEL		DRILLED SHAFT
						Size	(LF)	
Orange	G20-7T		96" X 48"	Type B <sub>FL</sub> or C <sub>FL</sub>	32	▲	▲	▲
Orange	G20-7T		192" X 96"	Type B <sub>FL</sub> or C <sub>FL</sub>	128	W8x18	16 17	12

▲ See Note 6 Below

**LEGEND**

	Sign
	Large Sign
	Traffic Flow

**DEPARTMENTAL MATERIAL SPECIFICATIONS**

PLYWOOD SIGN BLANKS	DMS-7100
ALUMINUM SIGN BLANKS	DMS-7110
SIGN FACE MATERIALS	DMS-8300

COLOR	USAGE	SHEETING MATERIAL
ORANGE	BACKGROUND	TYPE B <sub>FL</sub> OR TYPE C <sub>FL</sub>
BLACK	LEGEND & BORDERS	NON-REFLECTIVE ACRYLIC FILM

**GENERAL NOTES**

- See BC and SMD sheets for additional sign support details.
- Sign locations shall be approved by the Engineer.
- For projects more than two miles in length, Give Us a BRAKE signs should be repeated halfway through the project. The Give Us a Brake (CW21-1T) may be used for this purpose.
- Work zone speed limits are sometimes used in conjunction with GIVE US A BRAKE signing. See BC(3) for location and spacing of construction speed zone signing when required.
- Give Us a Brake (CW21-1T) signs and supports shall be considered subsidiary to Item 502, "Barricades, Signs and Traffic Handling."
- The 96" X 48" Working For You Give Us A BRAKE (G20-7T) may use a 1/2" or 5/8" plywood substrate or 0.125" aluminum sheeting substrate and may be supported by two 4" x 6" wood posts with drilled holes for breakaway as per BC(5) and will be subsidiary to Item 502.
- The Working For You Give Us A BRAKE (G20-7T) 192" X 96" sign shall be paid for under the following specification items:  
 Item 636 - Aluminum Signs  
 Item 647 - Large Roadside Sign Supports and Assemblies.  
 Item 416 - Drilled Shaft Foundations
- All signs shall be constructed in accordance with the details found in the "Standard Highway Sign Designs for Texas," latest edition. Sign details not shown in this manual shall be shown in the plans or the Engineer shall provide a detail to the Contractor before the sign is manufactured.



**WORK ZONE  
"GIVE US A BRAKE"  
SIGNS**

**WZ (BRK) - 13**

FILES: wzork-13.dgn	DATE: TxDOT	DATE: TxDOT	DATE: TxDOT	DATE: TxDOT
© TxDOT August 1995	CONT	SECT	JOB	HIGHWAY
REVISIONS	1603	03	042	FM 1709
6-96 5-98 7-13	DIST	COUNTY		SHEET NO.
8-96 3-03	FTW	TARRANT		010

DISCLAIMER: The use of this standard is governed by the "Texas Engineering Practice Act". No warranty of any kind is made by TxDOT for any purpose whatsoever. TxDOT assumes no responsibility for the conversion of this standard to other formats or for incorrect results or damages resulting from its use.

**BARRICADE AND CONSTRUCTION (BC) STANDARD SHEETS GENERAL NOTES:**

1. The Barricade and Construction Standard Sheets (BC sheets) are intended to show typical examples for placement of temporary traffic control devices, construction pavement markings, and typical work zone signs. The information contained in these sheets meet or exceed the requirements shown in the "Texas Manual on Uniform Traffic Control Devices" (TMUTCD).
2. The development and design of the Traffic Control Plan (TCP) is the responsibility of the Engineer.
3. The Contractor may propose changes to the TCP that are signed and sealed by a licensed professional engineer for approval. The Engineer may develop, sign and seal Contractor proposed changes.
4. The Contractor is responsible for installing and maintaining the traffic control devices as shown in the plans. The Contractor may not move or change the approximate location of any device without the approval of the Engineer.
5. Geometric design of lane shifts and detours should, when possible, meet the applicable design criteria contained in manuals such as the American Association of State Highway and Transportation Officials (AASHTO), "A Policy on Geometric Design of Highways and Streets," the TxDOT "Roadway Design Manual" or engineering judgment.
6. When projects abut, the Engineer(s) may omit the END ROAD WORK, TRAFFIC FINES DOUBLE, and other advance warning signs if the signing would be redundant and the work areas appear continuous to the motorists. If the adjacent project is completed first, the Contractor shall erect the necessary warning signs as shown on these sheets, the TCP sheets or as directed by the Engineer. The BEGIN ROAD WORK NEXT X MILES sign shall be revised to show appropriate work zone distance.
7. The Engineer may require duplicate warning signs on the median side of divided highways where median width will permit and traffic volumes justify the signing.
8. All signs shall be constructed in accordance with the details found in the "Standard Highway Sign Designs for Texas," latest edition. Sign details not shown in this manual shall be shown in the plans or the Engineer shall provide a detail to the Contractor before the sign is manufactured.
9. The temporary traffic control devices shown in the illustrations of the BC sheets are examples. As necessary, the Engineer will determine the most appropriate traffic control devices to be used.
10. Where highway construction or maintenance work is being undertaken, other than mobile operations as defined by the Texas Manual on Uniform Traffic Control Devices, CSJ limit signs are required. CSJ limit signs are shown on BC(2). The OBEY WARNING SIGNS STATE LAW sign, STAY ALERT TALK OR TEXT LATER and the WORK ZONE TRAFFIC FINES DOUBLE sign with plaque shall be erected in advance of the CSJ limits. The BEGIN ROAD WORK NEXT X MILES, CONTRACTOR and END ROAD WORK signs shall be erected at or near the CSJ limits. For mobile operations, CSJ limit signs are not required.
11. Traffic control devices should be in place only while work is actually in progress or a definite need exists.
12. The Engineer has the final decision on the location of all traffic control devices.
13. Inactive equipment and work vehicles, including workers' private vehicles must be parked away from travel lanes. They should be as close to the right-of-way line as possible, or located behind a barrier or guardrail, or as approved by the Engineer.

DATE:  
FILE:

**WORKER SAFETY NOTES:**

1. Workers on foot who are exposed to traffic or to construction equipment within the right-of-way shall wear high-visibility safety apparel meeting the requirements of ISEA "American National Standard for High-Visibility Apparel," or equivalent revisions, and labeled as ANSI 107-2004 standard performance for Class 2 or 3 risk exposure. Class 3 garments should be considered for high traffic volume work areas or night time work.
2. Except in emergency situations, flagger stations shall be illuminated when flagging is used at night.

**COMPLIANT WORKZONE TRAFFIC CONTROL DEVICES**

1. Only pre-qualified products shall be used. The "Compliant Work Zone Traffic Control Devices List" (CWZTCD) describes pre-qualified products and their sources.
2. Work zone traffic control devices shall be compliant with the Manual for Assessing safety Hardware (MASH).

<p><b>THE DOCUMENTS BELOW CAN BE FOUND ON-LINE AT</b>  <a href="http://www.txdot.gov">http://www.txdot.gov</a></p>
COMPLIANT WORK ZONE TRAFFIC CONTROL DEVICES LIST (CWZTCD)
DEPARTMENTAL MATERIAL SPECIFICATIONS (DMS)
MATERIAL PRODUCER LIST (MPL)
ROADWAY DESIGN MANUAL - SEE "MANUALS (ONLINE MANUALS)"
STANDARD HIGHWAY SIGN DESIGNS FOR TEXAS (SHSD)
TEXAS MANUAL ON UNIFORM TRAFFIC CONTROL DEVICES (TMUTCD)
TRAFFIC ENGINEERING STANDARD SHEETS

 Texas Department of Transportation		Traffic Safety Division Standard	
<p><b>BARRICADE AND CONSTRUCTION GENERAL NOTES AND REQUIREMENTS</b></p> <p><b>BC(1) - 21</b></p>			
FILE:	bc-21.dgn	DN: TxDOT	CR: TxDOT
© TxDOT	November 2002	CON: 1603	SECT: 03
	REVISIONS	JOB: 042	HIGHWAY: FM 1709
4-03	7-13	DIST:	COUNTY:
9-07	8-14	FTW:	TARRANT
5-10	5-21	SHEET NO:	011

DISCLAIMER: The use of this standard is governed by the "Texas Engineering Practice Act". No warranty of any kind is made by TxDOT for any purpose whatsoever. TxDOT assumes no responsibility for the conversion of this standard to other formats or for incorrect results or damages resulting from its use.

**TYPICAL LOCATION OF CROSSROAD SIGNS**

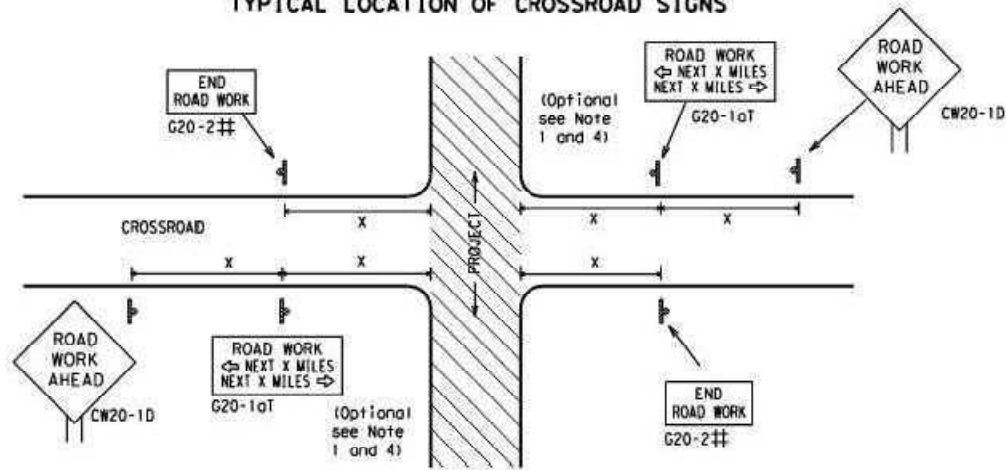

- ## May be mounted on back of "ROAD WORK AHEAD" (CW20-1D) sign with approval of Engineer. (See note 2 below)
- The typical minimum signing on a crossroad approach should be a "ROAD WORK AHEAD" (CW20-1D) sign and a (G20-2) "END ROAD WORK" sign, unless noted otherwise in plans.
  - The Engineer may use the reduced size 36" x 36" ROAD WORK AHEAD (CW20-1D) sign mounted back to back with the reduced size 36" x 18" END ROAD WORK (G20-2) sign on low volume crossroads (See Note 4 under "Typical Construction Warning Sign Size and Spacing"). See the "Standard Highway Signs Design for Texas" manual for sign details. The Engineer may omit the advance warning signs on low volume crossroads. The Engineer will determine whether a road is low volume as per TMUTCD Part 5. This information shall be shown in the plans.
  - Based on existing field conditions, the Engineer/Inspector may require additional signs such as FLAGGER AHEAD, LOOSE GRAVEL, or other appropriate signs. When additional signs are required, these signs will be considered part of the minimum requirements. The Engineer/Inspector will determine the proper location and spacing of any sign not shown on the BC sheets, Traffic Control Plan sheets or the Work Zone Standard Sheets.
  - The "ROAD WORK NEXT X MILES" (G20-1aT) sign shall be required at high volume crossroads to advise motorists of the length of construction in either direction from the intersection. The Engineer will determine whether a roadway is considered high volume.
  - Additional traffic control devices may be shown elsewhere in the plans for higher volume crossroads.
  - When work occurs in the intersection area, appropriate traffic control devices, as shown elsewhere in the plans or as determined by the Engineer/Inspector, shall be in place.

**T-INTERSECTION**

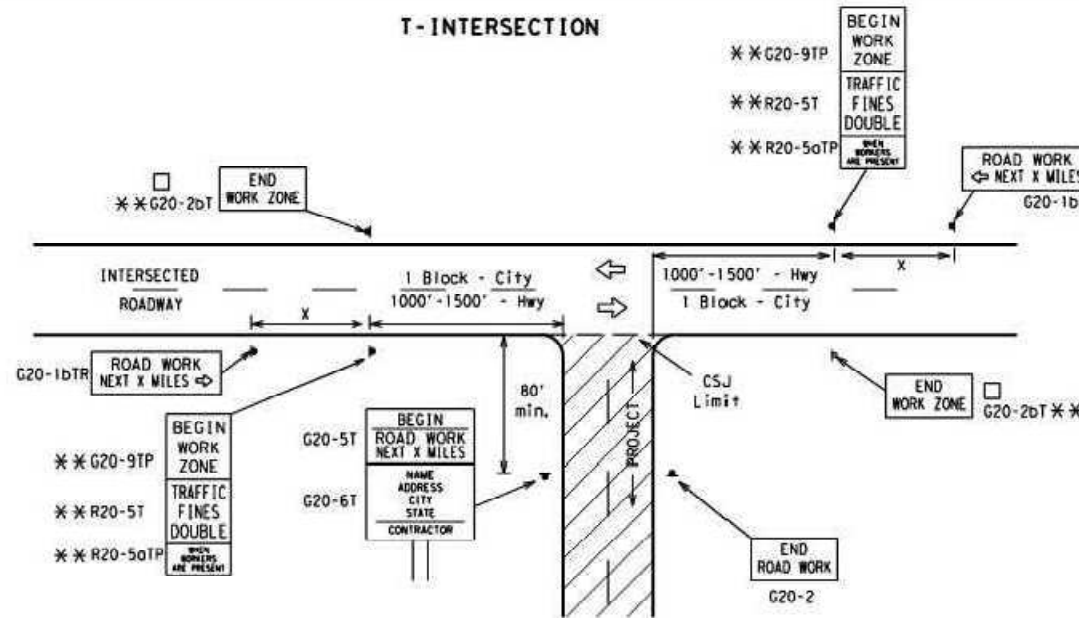

**CSJ LIMITS AT T-INTERSECTION**

- The Engineer will determine the types and location of any additional traffic control devices, such as a flagger and accompanying signs, or other signs, that should be used when work is being performed at or near an intersection.
- If construction closes the road at a T-intersection, the Contractor shall place the "CONTRACTOR NAME" (G20-6T) sign behind the Type 3 Barricades for the road closure (see BC(10) also). The "ROAD WORK NEXT X MILES" left arrow (G20-1bTL) and "ROAD WORK NEXT X MILES" right arrow (G20-1bTR) signs shall be replaced by the detour signing called for in the plans.

**TYPICAL CONSTRUCTION WARNING SIGN SIZE AND SPACING<sup>1,5,6</sup>**

Sign Number or Series	SIZE		SPACING	
	Conventional Road	Expressway/Freeway	Posted Speed MPH	Sign Spacing "X" Feet (Approx.)
CW20 <sup>4</sup>	48" x 48"	48" x 48"	30	120
CW21			35	160
CW22			40	240
CW23			45	320
CW25	36" x 36"	48" x 48"	50	400
CW1, CW2, CW7, CW8, CW9, CW11, CW14			55	500 <sup>2</sup>
			60	600 <sup>2</sup>
			65	700 <sup>2</sup>
CW3, CW4, CW5, CW6, CW8-3, CW10, CW12	48" x 48"	48" x 48"	70	800 <sup>2</sup>
			75	900 <sup>2</sup>
			80	1000 <sup>2</sup>
	*	*	*	* <sup>3</sup>

\* For typical sign spacings on divided highways, expressways and freeways, see Part 6 of the "Texas Manual on Uniform Traffic Control Devices" (TMUTCD) typical application diagrams or TCP Standard Sheets.

△ Minimum distance from work area to first Advance Warning sign nearest the work area and/or distance between each additional sign.

**GENERAL NOTES**

- Special or larger size signs may be used as necessary.
- Distance between signs should be increased as required to have 1500 feet advance warning.
- Distance between signs should be increased as required to have 1/2 mile or more advance warning.
- 36" x 36" "ROAD WORK AHEAD" (CW20-1D) signs may be used on low volume crossroads at the discretion of the Engineer as per TMUTCD Part 5. See Note 2 under "Typical Location of Crossroad Signs".
- Only diamond shaped warning sign sizes are indicated.
- See sign size listing in "TMUTCD", Sign Appendix or the "Standard Highway Signs Design for Texas" manual for complete list of available sign design sizes.

**WORK AREAS IN MULTIPLE LOCATIONS WITHIN CSJ LIMITS**

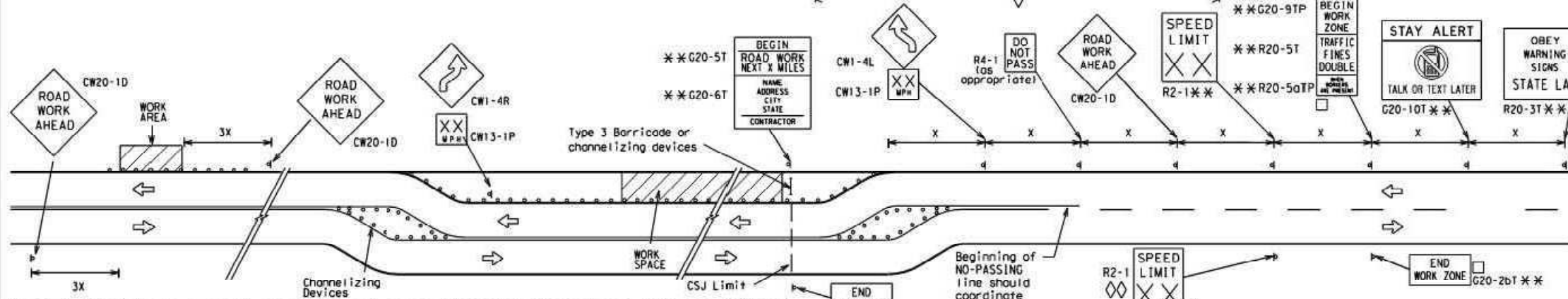

When extended distances occur between minimal work spaces, the Engineer/Inspector should ensure additional "ROAD WORK AHEAD" (CW20-1D) signs are placed in advance of these work areas to remind drivers they are still within the project limits. See the applicable TCP sheets for exact location and spacing of signs and channelizing devices.

**SAMPLE LAYOUT OF SIGNING FOR WORK BEGINNING DOWNSTREAM OF THE CSJ LIMITS**

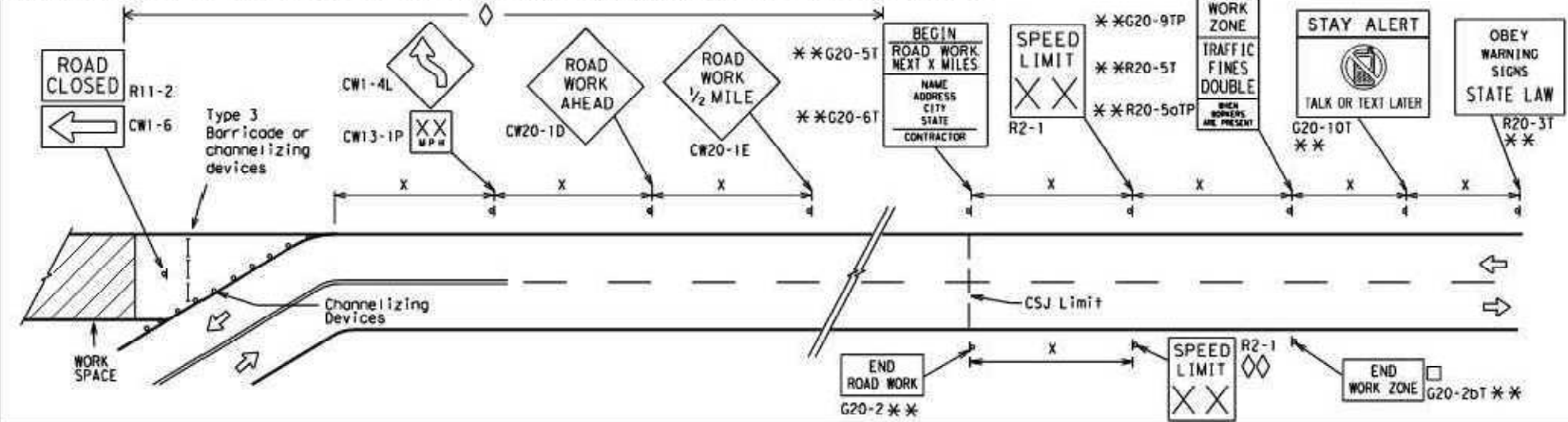

**NOTES**

- The Contractor shall determine the appropriate distance to be placed on the G20-1 series signs and "BEGIN ROAD WORK NEXT X MILES" (G20-5T) sign for each specific project. This distance shall replace the "X" and shall be rounded to the nearest whole mile with the approval of the Engineer. No decimals shall be used.
- The "BEGIN WORK ZONE" (G20-9TP) and "END WORK ZONE" (G20-2bT) shall be used as shown on the sample layout when advance signs are required outside the CSJ Limits. They inform the motorist of entering or leaving a part of the work zone lying outside the CSJ Limits where traffic fines may double if workers are present.
  - \*\* CSJ limit signing is required for highway construction and maintenance work, with the exception of mobile operations.
  - ◇ Area for placement of "ROAD WORK AHEAD" (CW20-1D) sign and other signs or devices as called for on the Traffic Control Plan.
  - ◇◇ Contractor will install a regulatory speed limit sign at the end of the work zone.

LEGEND	
—	Type 3 Barricade
○ ○ ○	Channelizing Devices
■	Sign
X	See Typical Construction Warning Sign Size and Spacing chart or the TMUTCD for sign spacing requirements.

SHEET 2 OF 12

Texas Department of Transportation  
Traffic Safety Division Standard

**BARRICADE AND CONSTRUCTION PROJECT LIMIT**

BC(2)-21

FILE: bc-21.dgn	DATE: TxDOT	BY: TxDOT	CHK: TxDOT	DATE: TxDOT	CHK: TxDOT
© TxDOT November 2002	CONT: 1603	SECT: 03	JOB: 042	PROJECT: FM 1709	
REVISIONS:	DATE: 9-07	BY: 8-14	CHK: 7-13	DATE: 5-21	
	DIST: FTW	COUNTY: TARRANT	SHEET NO: 012		

DATE: FILE:

# TYPICAL APPLICATION OF WORK ZONE SPEED LIMIT SIGNS

Work zone speed limits shall be regulatory, established in accordance with the "Procedures for Establishing Speed Zones," and approved by the Texas Transportation Commission, or by City Ordinance when within Incorporated City Limits.

Reduced speeds should only be posted in the vicinity of work activity and not throughout the entire project. Regulatory work zone speed signs (R2-1) shall be removed or covered during periods when they are not needed.

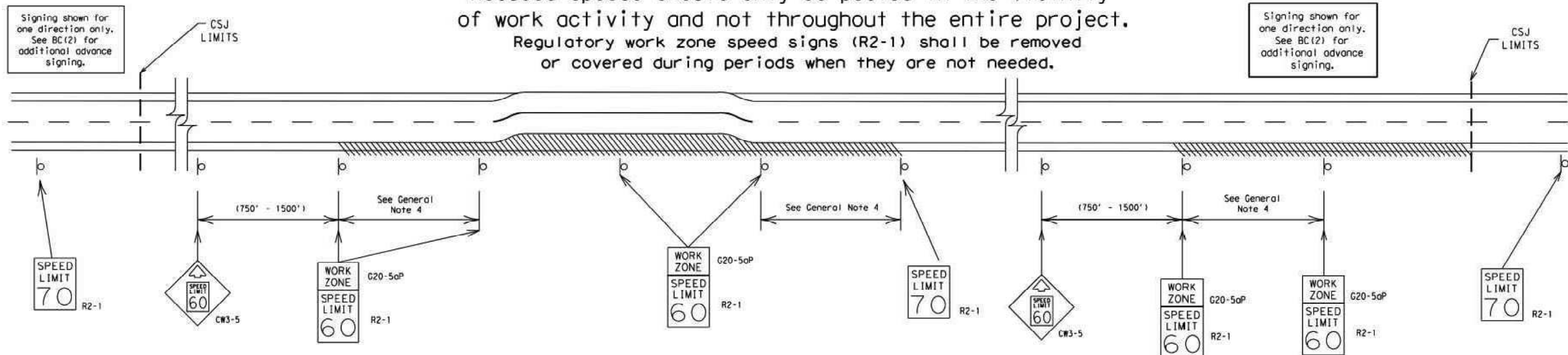

## GUIDANCE FOR USE:

### LONG/INTERMEDIATE TERM WORK ZONE SPEED LIMITS

This type of work zone speed limit should be included on the design of the traffic control plans when restricted geometrics with a lower design speed are present in the work zone and modification of the geometrics to a higher design speed is not feasible.

Long/Intermediate Term Work Zone Speed Limit signs, when approved as described above, should be posted and visible to the motorist when work activity is present. Work activity may also be defined as a change in the roadway that requires a reduced speed for motorists to safely negotiate the work area, including:

- rough road or damaged pavement surface
- substantial alteration of roadway geometrics (diversions)
- construction detours
- grade
- width
- other conditions readily apparent to the driver

As long as any of these conditions exist, the work zone speed limit signs should remain in place.

### SHORT TERM WORK ZONE SPEED LIMITS

This type of work zone speed limit may be included on the design of the traffic control plans when workers or equipment are not behind concrete barrier, when work activity is within 10 feet of the traveled way or actually in the traveled way.

Short Term Work Zone Speed Limit signs should be posted and visible to the motorists only when work activity is present. When work activity is not present, signs shall be removed or covered. (See Removing or Covering on BC(4)).

## GENERAL NOTES

- Regulatory work zone speed limits should be used only for sections of construction projects where speed control is of major importance.
- Regulatory work zone speed limit signs shall be placed on supports at a 7 foot minimum mounting height.
- Speed zone signs are illustrated for one direction of travel and are normally posted for each direction of travel.
- Frequency of work zone speed limit signs should be:
  - 40 mph and greater 0.2 to 2 miles
  - 35 mph and less 0.2 to 1 mile
- Regulatory speed limit signs shall have black legend and border on a white reflective background (See "Reflective Sheeting" on BC(4)).
- Fabrication, erection and maintenance of the "ADVANCE SPEED LIMIT" (CW3-5) sign, "WORK ZONE" (G20-5aP) plaque and the "SPEED LIMIT" (R2-1) signs shall not be paid for directly, but shall be considered subsidiary to Item 502.
- Turning signs from view, laying signs over or down will not be allowed, unless as otherwise noted under "REMOVING OR COVERING" on BC(4).
- Techniques that may help reduce traffic speeds include but are not limited to:
  - Law enforcement.
  - Flagger stationed next to sign.
  - Portable changeable message sign (PCMS).
  - Low-power (drone) radar transmitter.
  - Speed monitor trailers or signs.
- Speeds shown on details above are for illustration only. Work Zone Speed Limits should only be posted as approved for each project.
- For more specific guidance concerning the type of work, work zone conditions and factors impacting allowable regulatory construction speed zone reduction see TxDOT form #1204 in the TxDOT e-form system.

DISCLAIMER: The use of this standard is governed by the "Texas Engineering Practice Act". No warranty of any kind is made by TxDOT for any purpose whatsoever. TxDOT assumes no responsibility for the conversion of this standard to other formats or for incorrect results or damages resulting from its use.

DATE: FILE:

SHEET 3 OF 12

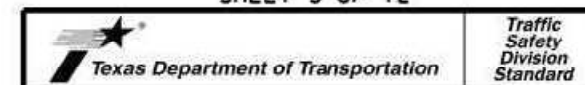

## BARRICADE AND CONSTRUCTION WORK ZONE SPEED LIMIT

BC (3) - 21

FILE#	bc-21.dgn	DN# TxDOT	CK# TxDOT	DN# TxDOT	CK# TxDOT
©TxDOT	November 2002	CONT	SECT	JOB	HIGHWAY
9-07	8-14	1603	03	042	FM 1709
7-13	5-21	DIST	COUNTY	SHEET NO.	
		FTW	TARRANT	013	



**TYPICAL MINIMUM CLEARANCES FOR LONG TERM AND INTERMEDIATE TERM SIGNS**

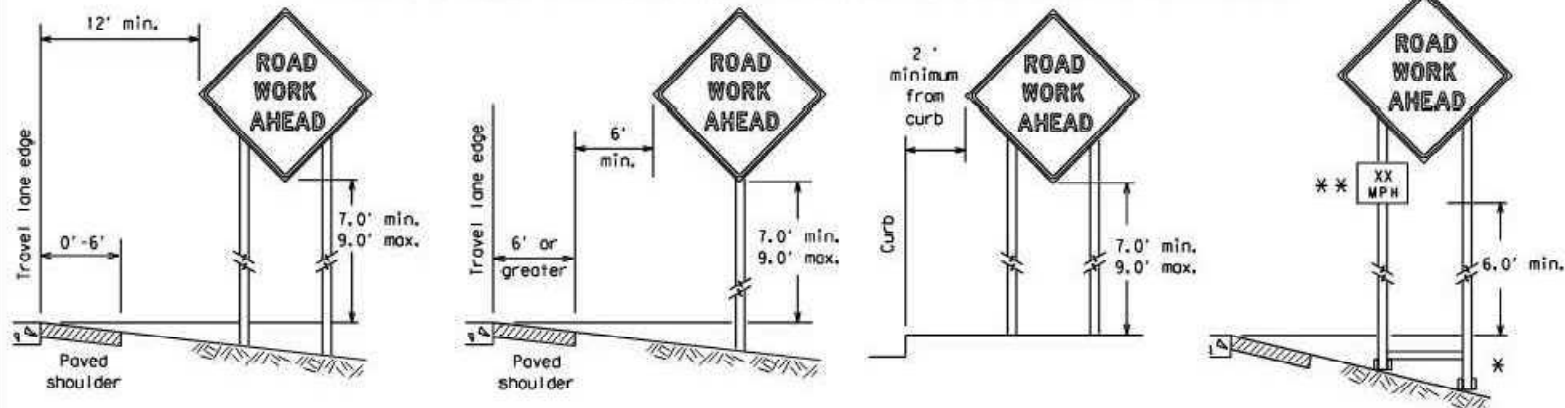

\* When placing skid supports on unlevel ground, the leg post lengths must be adjusted so the sign appears straight and plumb. Objects shall NOT be placed under skids as a means of leveling.

\*\* When plaques are placed on dual-leg supports, they should be attached to the upright nearest the travel lane. Supplemental plaques (advisory or distance) should not cover the surface of the parent sign.

**ATTACHMENT FOR SIGN SUPPORTS**

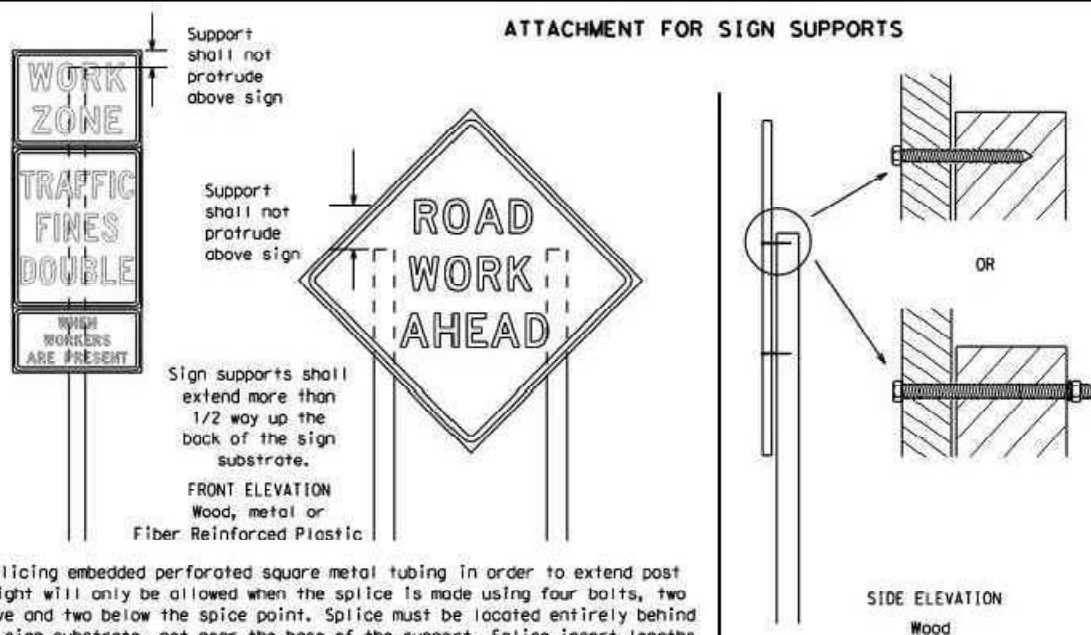

Splicing embedded perforated square metal tubing in order to extend post height will only be allowed when the splice is made using four bolts, two above and two below the splice point. Splice must be located entirely behind the sign substrate, not near the base of the support. Splice insert lengths should be at least 5 times nominal post size, centered on the splice and of at least the same gauge material.

**GENERAL NOTES FOR WORK ZONE SIGNS**

- Contractor shall install and maintain signs in a straight and plumb condition and/or as directed by the Engineer.
- Wooden sign posts shall be painted white.
- Barricades shall NOT be used as sign supports.
- All signs shall be installed in accordance with the plans or as directed by the Engineer. Signs shall be used to regulate, warn, and guide the traveling public safely through the work zone.
- The Contractor may furnish either the sign design shown in the plans or in the "Standard Highway Sign Designs for Texas" (SHSD). The Engineer/Inspector may require the Contractor to furnish other work zone signs that are shown in the TMUTCD but may have been omitted from the plans. Any variation in the plans shall be documented by written agreement between the Engineer and the Contractor's Responsible Person. All changes must be documented in writing before being implemented. This can include documenting the changes in the Inspector's TxDOT diary and having both the Inspector and Contractor initial and date the agreed upon changes.
- The Contractor shall furnish sign supports listed in the "Compliant Work Zone Traffic Control Device List" (CWZTCD) for small roadside signs. Supports for temporary large roadside signs shall meet the requirements detailed on the Temporary Large Roadside Signs (TLRS) standard sheets. The Contractor shall install the sign support in accordance with the manufacturer's recommendations. If there is a question regarding installation procedures, the Contractor shall furnish the Engineer a copy of the manufacturer's installation recommendations so the Engineer can verify the correct procedures are being followed.
- The Contractor is responsible for installing signs on approved supports and replacing signs with damaged or cracked substrates and/or damaged or marred reflective sheeting as directed by the Engineer/Inspector.
- Identification markings may be shown only on the back of the sign substrate. The maximum height of letters and/or company logos used for identification shall be 1 inch.
- The Contractor shall replace damaged wood posts. New or damaged wood sign posts shall not be spliced.

**DURATION OF WORK (as defined by the "Texas Manual on Uniform Traffic Control Devices" Part 6)**

- The types of sign supports, sign mounting height, the size of signs, and the type of sign substrates can vary based on the type of work being performed. The Engineer is responsible for selecting the appropriate size sign for the type of work being performed. The Contractor is responsible for ensuring the sign support, sign mounting height and substrate meets manufacturer's recommendations in regard to crashworthiness and duration of work requirements.
  - Long-term stationary - work that occupies a location more than 3 days.
  - Intermediate-term stationary - work that occupies a location more than one daylight period up to 3 days, or nighttime work lasting more than one hour.
  - Short-term stationary - daytime work that occupies a location for more than 1 hour in a single daylight period.
  - Short, duration - work that occupies a location up to 1 hour.
  - Mobile - work that moves continuously or intermittently (stopping for up to approximately 15 minutes.)

**SIGN MOUNTING HEIGHT**

- The bottom of Long-term/Intermediate-term signs shall be at least 7 feet, but not more than 9 feet, above the paved surface, except as shown for supplemental plaques mounted below other signs.
- The bottom of Short-term/Short Duration signs shall be a minimum of 1 foot above the pavement surface but no more than 2 feet above the ground.
- Long-term/Intermediate-term Signs may be used in lieu of Short-term/Short Duration signing.
- Short-term/Short Duration signs shall be used only during daylight and shall be removed at the end of the workday or raised to appropriate Long-term/Intermediate sign height.
- Regulatory signs shall be mounted at least 7 feet, but not more than 9 feet, above the paved surface regardless of work duration.

**SIZE OF SIGNS**

- The Contractor shall furnish the sign sizes shown on BC (2) unless otherwise shown in the plans or as directed by the Engineer.

**SIGN SUBSTRATES**

- The Contractor shall ensure the sign substrate is installed in accordance with the manufacturer's recommendations for the type of sign support that is being used. The CWZTCD lists each substrate that can be used on the different types and models of sign supports.
- "Mesh" type materials are NOT an approved sign substrate, regardless of the tightness of the weave.
- All wooden individual sign panels fabricated from 2 or more pieces shall have one or more plywood cleat, 1/2" thick by 6" wide, fastened to the back of the sign and extending fully across the sign. The cleat shall be attached to the back of the sign using wood screws that do not penetrate the face of the sign panel. The screws shall be placed on both sides of the splice and spaced at 6" centers. The Engineer may approve other methods of splicing the sign face.

**REFLECTIVE SHEETING**

- All signs shall be retroreflective and constructed of sheeting meeting the color and retro-reflectivity requirements of DMS-8300 for rigid signs or DMS-8310 for roll-up signs. The web address for DMS specifications is shown on BC(1).
- White sheeting, meeting the requirements of DMS-8300 Type A, shall be used for signs with a white background.
- Orange sheeting, meeting the requirements of DMS-8300 Type B<sub>FL</sub> or Type C<sub>FL</sub>, shall be used for rigid signs with orange backgrounds.

**SIGN LETTERS**

- All sign letters and numbers shall be clear, and open rounded type uppercase alphabet letters as approved by the Federal Highway Administration (FHWA) and as published in the "Standard Highway Sign Design for Texas" manual. Signs, letters and numbers shall be of first class workmanship in accordance with Department Standards and Specifications.

**REMOVING OR COVERING**

- When sign messages may be confusing or do not apply, the signs shall be removed or completely covered.
- Long-term stationary or intermediate stationary signs installed on square metal tubing may be turned away from traffic 90 degrees when the sign message is not applicable. This technique may not be used for signs installed in the median of divided highways or near any intersections where the sign may be seen from approaching traffic.
- Signs installed on wooden skids shall not be turned at 90 degree angles to the roadway. These signs should be removed or completely covered when not required.
- When signs are covered, the material used shall be opaque, such as heavy mil black plastic, or other materials which will cover the entire sign face and maintain their opaque properties under automobile headlights at night, without damaging the sign sheeting.
- Burlap shall NOT be used to cover signs.
- Duct tape or other adhesive material shall NOT be affixed to a sign face.
- Signs and anchor stubs shall be removed and holes backfilled upon completion of work.

**SIGN SUPPORT WEIGHTS**

- Where sign supports require the use of weights to keep from turning over, the use of sandbags with dry, cohesionless sand should be used.
- The sandbags will be tied shut to keep the sand from spilling and to maintain a constant weight.
- Rock, concrete, iron, steel or other solid objects shall not be permitted for use as sign support weights.
- Sandbags should weigh a minimum of 35 lbs and a maximum of 50 lbs.
- Sandbags shall be made of a durable material that tears upon vehicular impact. Rubber (such as tire inner tubes) shall NOT be used.
- Rubber ballasts designed for channelizing devices should not be used for ballast on portable sign supports. Sign supports designed and manufactured with rubber bases may be used when shown on the CWZTCD list.
- Sandbags shall only be placed along or laid over the base supports of the traffic control device and shall not be suspended above ground level or hung with rope, wire, chains or other fasteners. Sandbags shall be placed along the length of the skids to weigh down the sign support.
- Sandbags shall NOT be placed under the skid and shall not be used to level sign supports placed on slopes.

**FLAGS ON SIGNS**

- Flags may be used to draw attention to warning signs. When used, the flag shall be 16 inches square or larger and shall be orange or fluorescent red-orange in color. Flags shall not be allowed to cover any portion of the sign face.

**STOP/SLOW PADDLES**

- STOP/SLOW paddles are the primary method to control traffic by flaggers. The STOP/SLOW paddle size should be 24" x 24".
- STOP/SLOW paddles shall be retroreflectORIZED when used at night.
- STOP/SLOW paddles may be attached to a staff with a minimum length of 6' to the bottom of the sign.
- Any lights incorporated into the STOP or SLOW paddle faces shall only be as specifically described in Section 6E.03 Hand Signaling Devices in the TMUTCD.

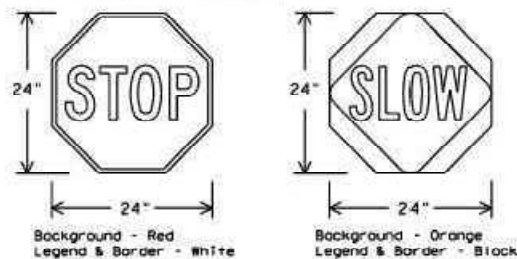

SHEETING REQUIREMENTS (WHEN USED AT NIGHT)		
USAGE	COLOR	SIGN FACE MATERIAL
BACKGROUND	RED	TYPE B OR C SHEETING
BACKGROUND	ORANGE	TYPE B <sub>FL</sub> OR C <sub>FL</sub> SHEETING
LEGEND & BORDER	WHITE	TYPE B OR C SHEETING
LEGEND & BORDER	BLACK	ACRYLIC NON-REFLECTIVE FILM

**CONTRACTOR REQUIREMENTS FOR MAINTAINING PERMANENT SIGNS WITHIN THE PROJECT LIMITS**

- Permanent signs are used to give notice of traffic laws or regulations, call attention to conditions that are potentially hazardous to traffic operations, show route designations, destinations, directions, distances, services, points of interest, and other geographical, recreational, specific service (LOGO), or cultural information. Drivers proceeding through a work zone need the same, if not better route guidance as normally installed on a roadway without construction.
- When permanent regulatory or warning signs conflict with work zone conditions, remove or cover the permanent signs until the permanent sign message matches the roadway condition. For details for covering large guide signs see the TS-CD standard.
- When existing permanent signs are moved and relocated due to construction purposes, they shall be visible to motorists at all times.
- If existing signs are to be relocated on their original supports, they shall be installed on crashworthy bases as shown on the SMD Standard sheets. The signs shall meet the required mounting heights shown on the BC Sheets or the SMD Standards. This work should be paid for under the appropriate pay item for relocating existing signs.
- If permanent signs are to be removed and relocated using temporary supports, the Contractor shall use crashworthy supports as shown on the BC standard sheets, TLRS standard sheets or the CWZTCD list. The signs shall meet the required mounting heights shown on the BC, or the SMD standard sheets during construction. This work should be paid for under the appropriate pay item for relocating existing signs.
- Any sign or traffic control device that is struck or damaged by the Contractor or his/her construction equipment shall be replaced as soon as possible by the Contractor to ensure proper guidance for the motorists. This will be subsidiary to Item 502.



**BARRICADE AND CONSTRUCTION TEMPORARY SIGN NOTES**

**BC (4) - 21**

FILE: BC-21.dgn	DATE: 11/03/02	BY: TXDOT	CHK: TXDOT	DATE: 11/03/02	BY: TXDOT	CHK: TXDOT
© TXDOT November 2002	REV: 1603	SECT: 03	JOB: 042	FM: 1709		
REVISIONS: 9-07 8-14	DIST: FTW	COUNTY: TARRANT	SHEET NO: 014			
7-13 5-21						

DISCLAIMER: The use of this standard is governed by the "Texas Engineering Practice Act". No warranty of any kind is made by TxDOT for any purpose whatsoever. TxDOT assumes no responsibility for the conversion of this standard to other formats or for incorrect results or damages resulting from its use.

DISCLAIMER: The use of this standard is governed by the "Texas Engineering Practice Act". No warranty of any kind is made by TxDOT for any purpose whatsoever. TxDOT assumes no responsibility for the conversion of this standard to other formats or for incorrect results or damages resulting from its use.

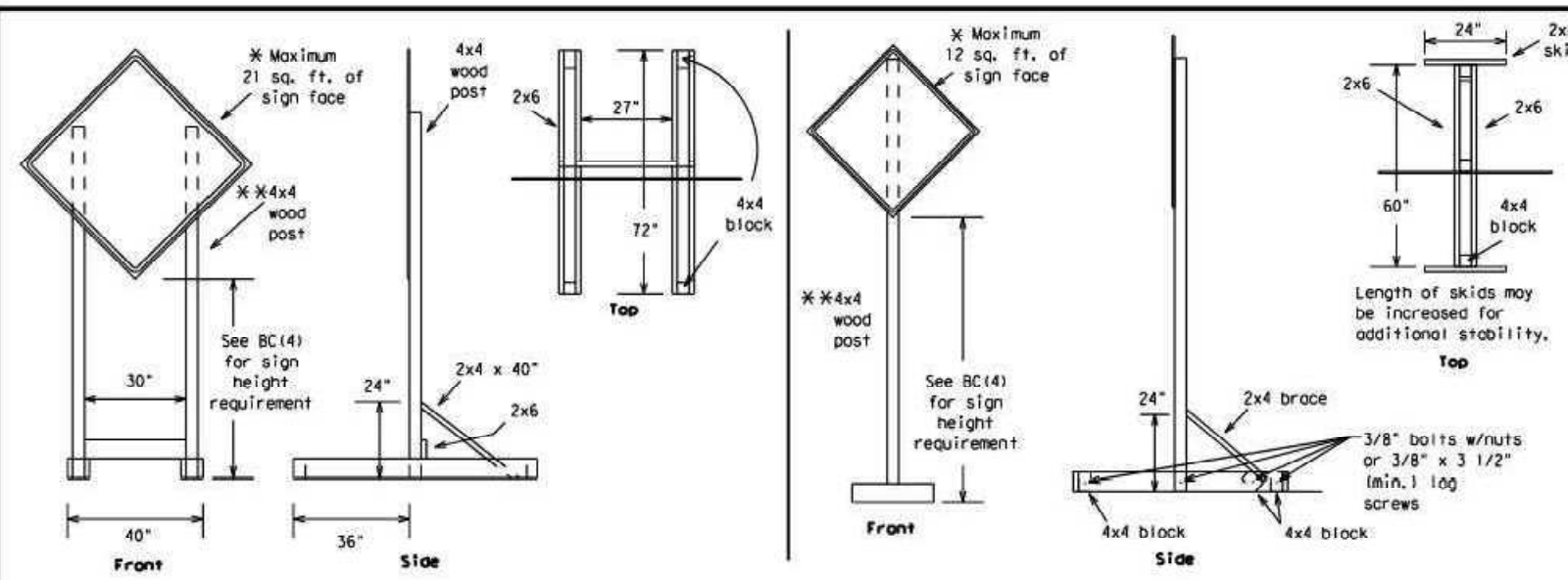

**SKID MOUNTED WOOD SIGN SUPPORTS**

\* LONG/INTERMEDIATE TERM STATIONARY - PORTABLE SKID MOUNTED SIGN SUPPORTS

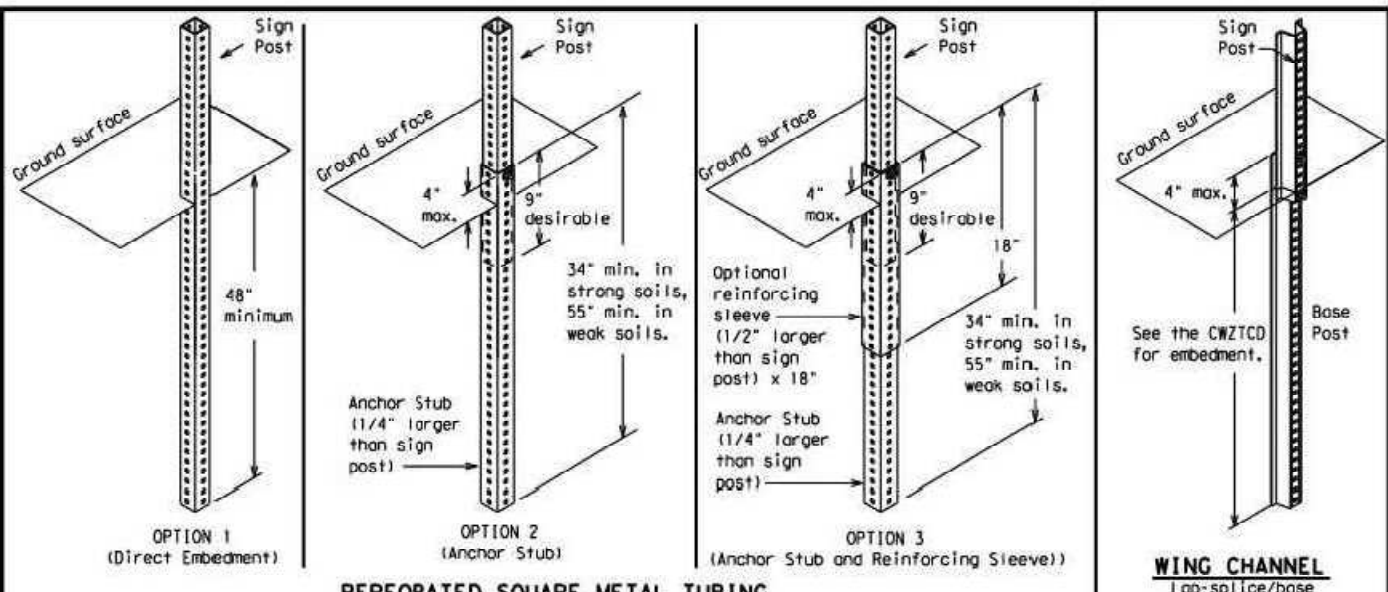

**GROUND MOUNTED SIGN SUPPORTS**

Refer to the CWZTCO and the manufacturer's installation procedure for each type sign support. The maximum sign square footage shall adhere to the manufacturer's recommendation. Two post installations can be used for larger signs.

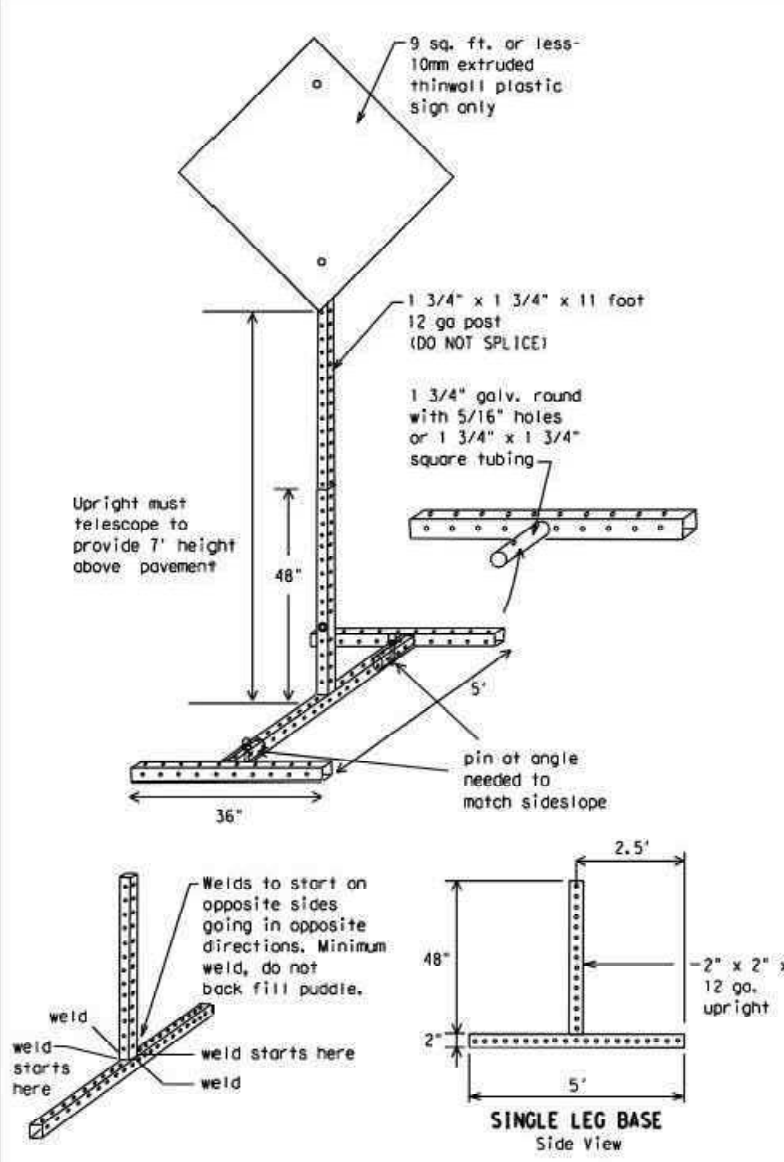

**SKID MOUNTED PERFORATED SQUARE STEEL TUBING SIGN SUPPORTS**

\* LONG/INTERMEDIATE TERM STATIONARY - PORTABLE SKID MOUNTED SIGN SUPPORTS

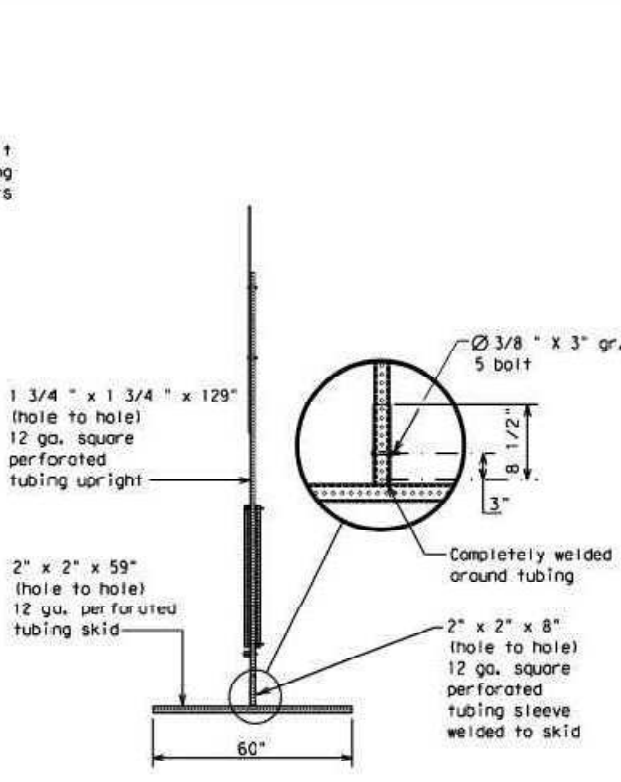
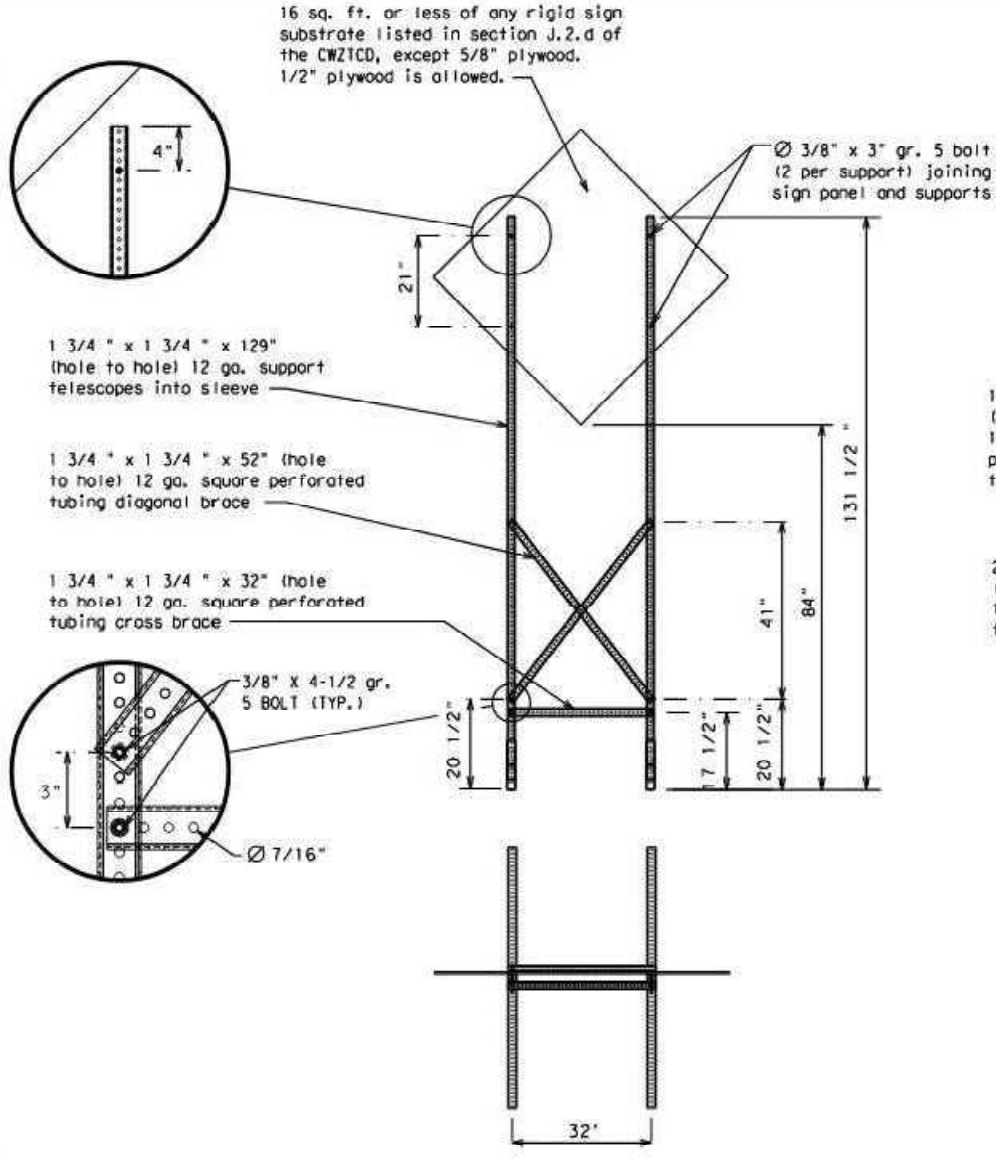

**WEDGE ANCHORS**

Both steel and plastic Wedge Anchor Systems as shown on the SMD Standard Sheets may be used as temporary sign supports for signs up to 10 square feet of sign face. They may be set in concrete or in sturdy soils if approved by the Engineer. (See web address for "Traffic Engineering Standard Sheets" on BC(1)).

**OTHER DESIGNS**

MORE DETAILS OF APPROVED LONG/INTERMEDIATE AND SHORT TERM SUPPORTS CAN BE FOUND ON THE CWZTCO LIST. SEE BC(1) FOR WEBSITE LOCATION.

**GENERAL NOTES**

- Nails may be used in the assembly of wooden sign supports, but 3/8" bolts with nuts or 3/8" x 3 1/2" lag screws must be used on every joint for final connection.
  - No more than 2 sign posts shall be placed within a 7 ft. circle, except for specific materials noted on the CWZTCO List.
  - When project is completed, all sign supports and foundations shall be removed from the project site. This will be considered subsidiary to Item 502.
- \* See BC(4) for definition of "Work Duration."  
 \*\* Wood sign posts MUST be one piece. Splicing will NOT be allowed. Posts shall be painted white.  
 See the CWZTCO for the type of sign substrate that can be used for each approved sign support.

SHEET 5 OF 12



**BARRICADE AND CONSTRUCTION TYPICAL SIGN SUPPORT**

BC(5)-21

FILE: bc-21.dgn	DATE: TxDOT	REV: TxDOT	DATE: TxDOT	REV: TxDOT
©TxDOT November 2002	CONT: 1603	SECT: 03	JOB: 042	HIGHWAY: FM 1709
REVISIONS:				
9-07 8-14	DIST: FTW	COUNTY: TARRANT	SHEET NO.:	015
7-13 5-21				

DATE: FILE:

WHEN NOT IN USE, REMOVE THE PCMS FROM THE RIGHT-OF-WAY OR PLACE THE PCMS BEHIND BARRIER OR GUARDRAIL WITH SIGN PANEL TURNED PARALLEL TO TRAFFIC

# RECOMMENDED PHASES AND FORMATS FOR PCMS MESSAGES DURING ROADWORK ACTIVITIES

(The Engineer may approve other messages not specifically covered here.)

## PORTABLE CHANGEABLE MESSAGE SIGNS

- The Engineer/Inspector shall approve all messages used on portable changeable message signs (PCMS).
- Messages on PCMS should contain no more than 8 words (about four to eight characters per word), not including simple words such as "TO," "FOR," "AT," etc.
- Messages should consist of a single phase, or two phases that alternate. Three-phase messages are not allowed. Each phase of the message should convey a single thought, and must be understood by itself.
- Use the word "EXIT" to refer to an exit ramp on a freeway; i.e., "EXIT CLOSED." Do not use the term "RAMP."
- Always use the route or interstate designation (IH, US, SH, FM) along with the number when referring to a roadway.
- When in use, the bottom of a stationary PCMS message panel should be a minimum 7 feet above the roadway, where possible.
- The message term "WEEKEND" should be used only if the work is to start on Saturday morning and end by Sunday evening at midnight. Actual days and hours of work should be displayed on the PCMS if work is to begin on Friday evening and/or continue into Monday morning.
- The Engineer/Inspector may select one of two options which are available for displaying a two-phase message on a PCMS. Each phase may be displayed for either four seconds each or for three seconds each.
- Do not "flash" messages or words included in a message. The message should be steady burn or continuous while displayed.
- Do not present redundant information on a two-phase message; i.e., keeping two lines of the message the same and changing the third line.
- Do not use the word "Danger" in message.
- Do not display the message "LANES SHIFT LEFT" or "LANES SHIFT RIGHT" on a PCMS. Drivers do not understand the message.
- Do not display messages that scroll horizontally or vertically across the face of the sign.
- The following table lists abbreviated words and two-word phrases that are acceptable for use on a PCMS. Both words in a phrase must be displayed together. Words or phrases not on this list should not be abbreviated, unless shown in the TMUTCD.
- PCMS character height should be at least 18 inches for trailer mounted units. They should be visible from at least 1/2 (.5) mile and the text should be legible from at least 600 feet at night and 800 feet in daylight. Truck mounted units must have a character height of 10 inches and must be legible from at least 400 feet.
- Each line of text should be centered on the message board rather than left or right justified.
- If disabled, the PCMS should default to an illegible display that will not alarm motorists and will only be used to alert workers that the PCMS has malfunctioned. A pattern such as a series of horizontal solid bars is appropriate.

## Phase 1: Condition Lists

### Road/Lane/Ramp Closure List

FREEWAY CLOSED X MILE	FRONTAGE ROAD CLOSED
ROAD CLOSED AT SH XXX	SHOULDER CLOSED XXX FT
ROAD CLSD AT FM XXXX	RIGHT LN CLOSED XXX FT
RIGHT X LANES CLOSED	RIGHT X LANES OPEN
CENTER LANE CLOSED	DAYTIME LANE CLOSURES
NIGHT LANE CLOSURES	I-XX SOUTH EXIT CLOSED
VARIOUS LANES CLOSED	EXIT XXX CLOSED X MILE
EXIT CLOSED	RIGHT LN TO BE CLOSED
MALL DRIVEWAY CLOSED	X LANES CLOSED TUE - FRI
XXXXXXXX BLVD CLOSED	

### Other Condition List

ROADWORK XXX FT	ROAD REPAIRS XXXX FT
FLAGGER XXXX FT	LANE NARROWS XXXX FT
RIGHT LN NARROWS XXXX FT	TWO-WAY TRAFFIC XX MILE
MERGING TRAFFIC XXXX FT	CONST TRAFFIC XXX FT
LOOSE GRAVEL XXXX FT	UNEVEN LANES XXXX FT
DETOUR X MILE	ROUGH ROAD XXXX FT
ROADWORK PAST SH XXXX	ROADWORK NEXT FRI-SUN
BUMP XXXX FT	US XXX EXIT X MILES
TRAFFIC SIGNAL XXXX FT	LANES SHIFT *

\* LANES SHIFT in Phase 1 must be used with STAY IN LANE in Phase 2.

## Phase 2: Possible Component Lists

### Action to Take/Effect on Travel List

MERGE RIGHT	FORM X LINES RIGHT
DETOUR NEXT X EXITS	USE XXXXX RD EXIT
USE EXIT XXX	USE EXIT I-XX NORTH
STAY ON US XXX SOUTH	USE I-XX E TO I-XX N
TRUCKS USE US XXX N	WATCH FOR TRUCKS
WATCH FOR TRUCKS	EXPECT DELAYS
EXPECT DELAYS	PREPARE TO STOP
REDUCE SPEED XXX FT	END SHOULDER USE
USE OTHER ROUTES	WATCH FOR WORKERS
STAY IN LANE *	

### Location List

AT FM XXXX
BEFORE RAILROAD CROSSING
NEXT X MILES
PAST US XXX EXIT
XXXXXXXX TO XXXXXXX
US XXX TO FM XXXX

### Warning List

SPEED LIMIT XX MPH
MAXIMUM SPEED XX MPH
MINIMUM SPEED XX MPH
ADVISORY SPEED XX MPH
RIGHT LANE EXIT
USE CAUTION
DRIVE SAFELY
DRIVE WITH CARE

### \*\* Advance Notice List

TUE-FRI XX AM-X PM
APR XX-X PM-X AM
BEGINS MONDAY
BEGINS MAY XX
MAY X-X XX PM - XX AM
NEXT FRI-SUN
XX AM TO XX PM
NEXT TUE AUG XX
TONIGHT XX PM-XX AM

\*\* See Application Guidelines Note 6.

## APPLICATION GUIDELINES

- Only 1 or 2 phases are to be used on a PCMS.
- The 1st phase (or both) should be selected from the "Road/Lane/Ramp Closure List" and the "Other Condition List".
- A 2nd phase can be selected from the "Action to Take/Effect on Travel, Location, General Warning, or Advance Notice Phase Lists".
- A Location Phase is necessary only if a distance or location is not included in the first phase selected.
- If two PCMS are used in sequence, they must be separated by a minimum of 1000 ft. Each PCMS shall be limited to two phases, and should be understandable by themselves.
- For advance notice, when the current date is within seven days of the actual work date, calendar days should be replaced with days of the week. Advance notification should typically be for no more than one week prior to the work.

## WORDING ALTERNATIVES

- The words RIGHT, LEFT and ALL can be interchanged as appropriate.
- Roadway designations IH, US, SH, FM and LP can be interchanged as appropriate.
- EAST, WEST, NORTH and SOUTH (or abbreviations E, W, N and S) can be interchanged as appropriate.
- Highway names and numbers replaced as appropriate.
- ROAD, HIGHWAY and FREEWAY can be interchanged as needed.
- AHEAD may be used instead of distances if necessary.
- FT and MI, MILE and MILES interchanged as appropriate.
- AT, BEFORE and PAST interchanged as needed.
- Distances or AHEAD can be eliminated from the message if a location phase is used.

PCMS SIGNS WITHIN THE R.O.W. SHALL BE BEHIND GUARDRAIL OR CONCRETE BARRIER OR SHALL HAVE A MINIMUM OF FOUR (4) PLASTIC DRUMS PLACED PERPENDICULAR TO TRAFFIC ON THE UPSTREAM SIDE OF THE PCMS, WHEN EXPOSED TO ONE DIRECTION OF TRAFFIC. WHEN EXPOSED TO TWO WAY TRAFFIC, THE FOUR DRUMS SHOULD BE PLACED WITH ONE DRUM AT EACH OF THE FOUR CORNERS OF THE UNIT.

## FULL MATRIX PCMS SIGNS

- When Full Matrix PCMS signs are used, the character height and legibility/visibility requirements shall be maintained as listed in Note 15 under "PORTABLE CHANGEABLE MESSAGE SIGNS" above.
- When symbol signs, such as the "Flagger Symbol" (CW20-7) are represented graphically on the Full Matrix PCMS sign and, with the approval of the Engineer, it shall maintain the legibility/visibility requirement listed above.
- When symbol signs are represented graphically on the Full Matrix PCMS, they shall only supplement the use of the static sign represented, and shall not substitute for, or replace that sign.
- A full matrix PCMS may be used to simulate a flashing arrow board provided it meets the visibility, flash rate and dimming requirements on BC(7), for the same size arrow.

DISCLAIMER: The use of this standard is governed by the "Texas Engineering Practice Act". No warranty of any kind is made by TxDOT for any purpose whatsoever. TxDOT assumes no responsibility for the conversion of this standard to other formats or for incorrect results or damages resulting from its use.

WORD OR PHRASE	ABBREVIATION	WORD OR PHRASE	ABBREVIATION
Access Road	ACCS RD	Major	MAJ
Alternate	ALT	Miles	MI
Avenue	AVE	Miles Per Hour	MPH
Best Route	BEST RTE	Minor	MNR
Boulevard	BLVD	Monday	MON
Bridge	BRDG	Normal	NORM
Canal	CANT	North	N
Center	CTR	Northbound	(route) N
Construction Ahead	CONST AHD	Parking	PKING
CROSSING	XING	Road	RD
Detour Route	DETOUR RTE	Right Lane	RT LN
Do Not	DONT	Saturday	SAT
East	E	Service Road	SERV RD
Eastbound	(route) E	Shoulder	SHLDR
Emergency	EMER	Slippery	SLIP
Emergency Vehicle	EMER VEH	South	S
Entrance, Enter	ENT	Southbound	(route) S
Express Lane	EXP LN	Speed	SPD
Expressway	EXPWY	Street	ST
XXXX Feet	XXXX FT	Sunday	SUN
Fog Ahead	FOG AHD	Telephone	PHONE
Freeway	FRWY, FWY	Temporary	TEMP
Freeway Blocked	FWY BLKD	Thursday	THURS
Friday	FRI	To Downtown	TO DWN TN
Hazardous Driving	HAZ DRIVING	Traffic	TRAF
Hazardous Material	HAZMAT	Travelers	TRVLRS
High-Occupancy Vehicle	HOV	Tuesday	TUES
Highway	HWY	Time Minutes	TIME MIN
Hour(s)	HR, HRS	Upper Level	UPR LEVEL
Information	INFO	Vehicles (s)	VEH, VEHS
It Is	ITS	Warning	WARN
Junction	JCT	Wednesday	WED
Left	LFT	Weight Limit	WT LIMIT
Left Lane	LFT LN	West	W
Lane Closed	LN CLOSED	Westbound	(route) W
Lower Level	LWR LEVEL	West Payment	WET PVMT
Maintenance	MAINT	Will Not	WONT

Roadway designation # IH-number, US-number, SH-number, FM-number

DATE: FILE:

<h3>BARRICADE AND CONSTRUCTION PORTABLE CHANGEABLE MESSAGE SIGN (PCMS)</h3>			
<h2>BC(6)-21</h2>			
FILE: bc-21.dgn	DATE: 09-07	REV: 8-14	REV: 7-13
CON: 1603	SECT: 03	JOB: 042	HIGHWAY: FM 1709
DIST: FTW		COUNTY: TARRANT	SHEET NO: 016

DISCLAIMER: The use of this standard is governed by the "Texas Engineering Practice Act". No warranty of any kind is made by TxDOT for any purpose whatsoever. TxDOT assumes no responsibility for the conversion of this standard to other formats or for incorrect results or damages resulting from its use.

- Barrier Reflectors shall be pre-qualified, and conform to the color and reflectivity requirements of DMS-8600. A list of prequalified Barrier Reflectors can be found at the Material Producer List web address shown on BC(1).
- Color of Barrier Reflectors shall be as specified in the TMTUCD. The cost of the reflectors shall be considered subsidiary to Item 512.

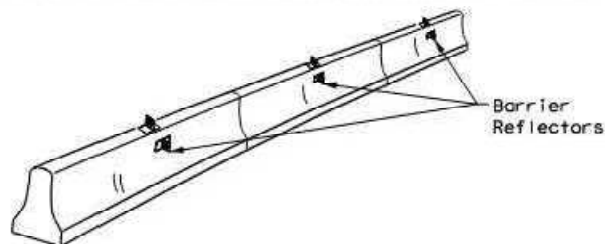

**CONCRETE TRAFFIC BARRIER (CTB)**

- Where traffic is on one side of the CTB, two (2) Barrier Reflectors shall be mounted in approximately the midsection of each section of CTB. An alternate mounting location is uniformly spaced at one end of each CTB. This will allow for attachment of a barrier grapple without damaging the reflector. The Barrier Reflector mounted on the side of the CTB shall be located directly below the reflector mounted on top of the barrier, as shown in the detail above.
- Where CTB separates two-way traffic, three barrier reflectors shall be mounted on each section of CTB. The reflector unit on top shall have two yellow reflective faces (Bi-Directional) while the reflectors on each side of the barrier shall have one yellow reflective face, as shown in the detail above.
- When CTB separates traffic traveling in the same direction, no barrier reflectors will be required on top of the CTB.
- Barrier Reflector units shall be yellow or white in color to match the edgeline being supplemented.
- Maximum spacing of Barrier Reflectors is forty (40) feet.
- Pavement markers or temporary flexible-reflective roadway marker tabs shall NOT be used as CTB delineation.
- Attachment of Barrier Reflectors to CTB shall be per manufacturer's recommendations.
- Missing or damaged Barrier Reflectors shall be replaced as directed by the Engineer.
- Single slope barriers shall be delineated as shown on the above detail.

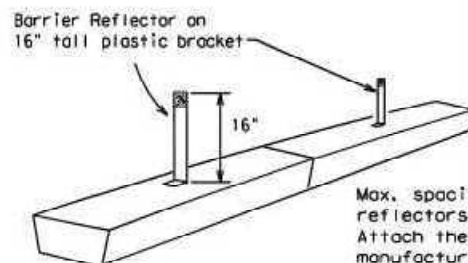

**LOW PROFILE CONCRETE BARRIER (LPCB) USED IN WORK ZONES**

LPCB is approved for use in work zone locations, where the posted speed is 45mph, or less. See Roadway Standard Sheet LPCB.

Max. spacing of barrier reflectors is 20 feet. Attach the delineators as per manufacturer's recommendations.

**LOW PROFILE CONCRETE BARRIER (LPCB)**

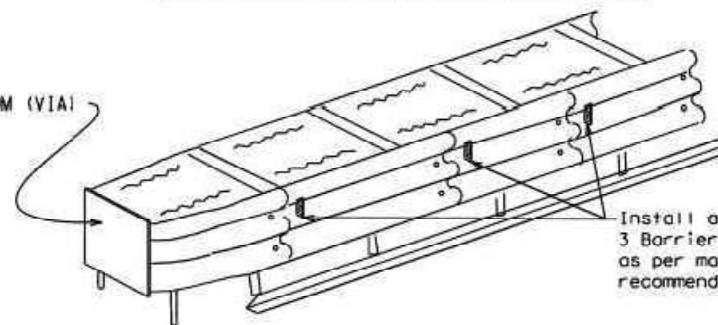

**DELINEATION OF END TREATMENTS**

**END TREATMENTS FOR CTB'S USED IN WORK ZONES**

End treatments used on CTB's in work zones shall meet the appropriate crashworthy standards as defined in the Manual for Assessing Safety Hardware (MASH). Refer to the CWZTCD List for approved end treatments and manufacturers.

**BARRIER REFLECTORS FOR CONCRETE TRAFFIC BARRIER AND ATTENUATORS**

**WARNING LIGHTS**

- Warning lights shall meet the requirements of the TMTUCD.
- Warning lights shall NOT be installed on barricades.
- Type A-Low Intensity Flashing Warning Lights are commonly used with drums. They are intended to warn of or mark a potentially hazardous area. Their use shall be as indicated on this sheet and/or other sheets of the plans by the designation "FL". The Type A Warning Lights shall not be used with signs manufactured with Type B<sub>PL</sub> or C<sub>PL</sub> Sheeting meeting the requirements of Departmental Material Specification DMS-8300.
- Type-C and Type D 360 degree Steady Burn Lights are intended to be used in a series for delineation to supplement other traffic control devices. Their use shall be as indicated on this sheet and/or other sheets of the plans by the designation "SB".
- The Engineer/Inspector or the plans shall specify the location and type of warning lights to be installed on the traffic control devices.
- When required by the Engineer, the Contractor shall furnish a copy of the warning lights certification. The warning light manufacturer will certify the warning lights meet the requirements of the latest ITE Purchase Specifications for Flashing and Steady-Burn Warning Lights.
- When used to delineate curves, Type-C and Type D Steady Burn Lights should only be placed on the outside of the curve, not the inside.
- The location of warning lights and warning reflectors on drums shall be as shown elsewhere in the plans.

**WARNING LIGHTS MOUNTED ON PLASTIC DRUMS**

- Type A flashing warning lights are intended to warn drivers that they are approaching or are in a potentially hazardous area.
- Type A random flashing warning lights are not intended for delineation and shall not be used in a series.
- A series of sequential flashing warning lights placed on channelizing devices to form a merging taper may be used for delineation. If used, the successive flashing of the sequential warning lights should occur from the beginning of the taper to the end of the merging taper in order to identify the desired vehicle path. The rate of flashing for each light shall be 65 flashes per minute, plus or minus 10 flashes.
- Type C and D steady-burn warning lights are intended to be used in a series to delineate the edge of the travel lane on detours, on lane changes, on lane closures, and on other similar conditions.
- Type A, Type C and Type D warning lights shall be installed at locations as detailed on other sheets in the plans.
- Warning lights shall not be installed on a drum that has a sign, chevron or vertical panel.
- The maximum spacing for warning lights on drums should be identical to the channelizing device spacing.

**WARNING REFLECTORS MOUNTED ON PLASTIC DRUMS AS A SUBSTITUTE FOR TYPE C (STEADY BURN) WARNING LIGHTS**

- A warning reflector or approved substitute may be mounted on a plastic drum as a substitute for a Type C, steady burn warning light at the discretion of the Contractor unless otherwise noted in the plans.
- The warning reflector shall be yellow in color and shall be manufactured using a sign substrate approved for use with plastic drums listed on the CWZTCD.
- The warning reflector shall have a minimum retroreflective surface area (one-side) of 30 square inches.
- Round reflectors shall be fully reflectorized, including the area where attached to the drum.
- Square substrates must have a minimum of 30 square inches of reflectorized sheeting. They do not have to be reflectorized where it attaches to the drum.
- The side of the warning reflector facing approaching traffic shall have sheeting meeting the color and retroreflectivity requirements for DMS 8300-Type B or Type C.
- When used near two-way traffic, both sides of the warning reflector shall be reflectorized.
- The warning reflector should be mounted on the side of the handle nearest approaching traffic.
- The maximum spacing for warning reflectors should be identical to the channelizing device spacing requirements.

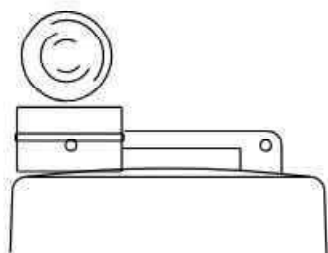

Type C Warning Light or approved substitute mounted on a drum adjacent to the travel way.

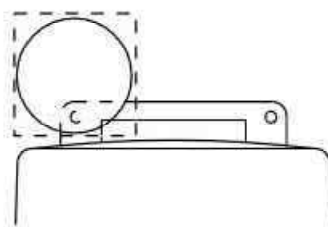

Warning reflector may be round or square. Must have a yellow reflective surface area of at least 30 square inches.

Arrow Boards may be located behind channelizing devices in place for a shoulder taper or merging taper, otherwise they shall be delineated with four (4) channelizing devices placed perpendicular to traffic on the upstream side of traffic.

- The Flashing Arrow Board should be used for all lane closures on multi-lane roadways, or slow moving maintenance or construction activities on the travel lanes.
- Flashing Arrow Boards should not be used on two-lane, two-way roadways, detours, diversions or work on shoulders unless the "CAUTION" display (see detail below) is used.
- The Engineer/Inspector shall choose all appropriate signs, barricades and/or other traffic control devices that should be used in conjunction with the Flashing Arrow Board.
- The Flashing Arrow Board should be able to display the following symbols:

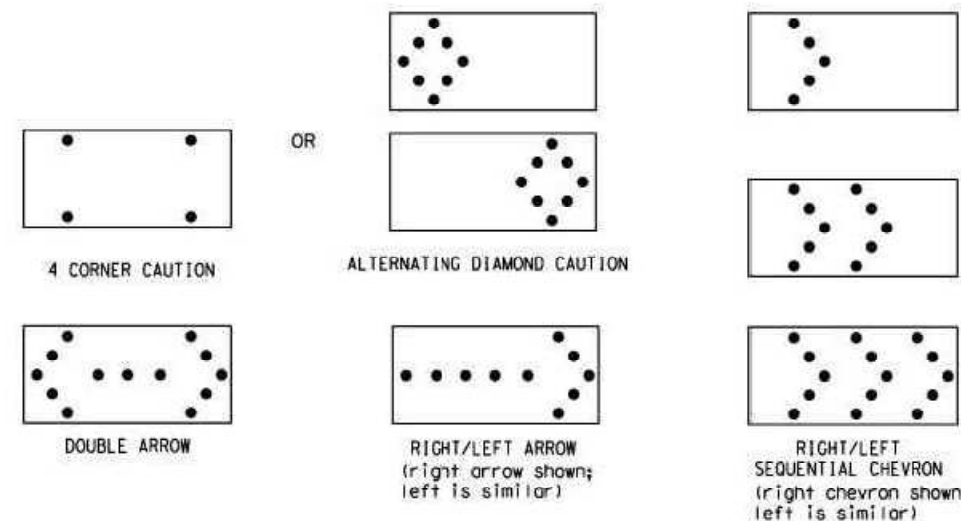

- The "CAUTION" display consists of four corner lamps flashing simultaneously, or the Alternating Diamond Caution mode as shown.
- The straight line caution display is NOT ALLOWED.
- The Flashing Arrow Board shall be capable of minimum 50 percent dimming from rated lamp voltage. The flashing rate of the lamps shall not be less than 25 nor more than 40 flashes per minute.
- Minimum lamp "on time" shall be approximately 50 percent for the flashing arrow and equal intervals of 25 percent for each sequential phase of the flashing chevron.
- The sequential arrow display is NOT ALLOWED.
- The flashing arrow display is the TxDOT standard; however, the sequential chevron display may be used during daylight operations.
- The Flashing Arrow Board shall be mounted on a vehicle, trailer or other suitable support.
- A Flashing Arrow Board SHALL NOT BE USED to laterally shift traffic.
- A full matrix PCMS may be used to simulate a Flashing Arrow Board provided it meets visibility, flash rate and dimming requirements on this sheet for the same size arrow.
- Minimum mounting height of trailer mounted Arrow Boards should be 7 feet from roadway to bottom of panel.

REQUIREMENTS			
TYPE	MINIMUM SIZE	MINIMUM NUMBER OF PANEL LAMPS	MINIMUM VISIBILITY DISTANCE
B	30 x 60	13	3/4 mile
C	48 x 96	15	1 mile

**ATTENTION**  
Flashing Arrow Boards shall be equipped with automatic dimming devices.

WHEN NOT IN USE, REMOVE THE ARROW BOARD FROM THE RIGHT-OF-WAY OR PLACE THE ARROW BOARD BEHIND CONCRETE TRAFFIC BARRIER OR GUARDRAIL.

**FLASHING ARROW BOARDS**

SHEET 7 OF 12

**TRUCK-MOUNTED ATTENUATORS**

- Truck-mounted attenuators (TMA) used on TxDOT facilities must meet the requirements outlined in the Manual for Assessing Safety Hardware (MASH).
- Refer to the CWZTCD for the requirements of Level 2 or Level 3 TMAs.
- Refer to the CWZTCD for a list of approved TMAs.
- TMAs are required on freeways unless otherwise noted in the plans.
- A TMA should be used anytime that it can be positioned 30 to 100 feet in advance of the area of crew exposure without adversely affecting the work performance.
- The only reason a TMA should not be required is when a work area is spread down the roadway and the work crew is an extended distance from the TMA.

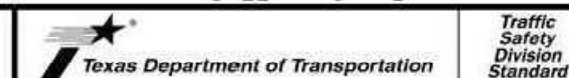

**BARRICADE AND CONSTRUCTION ARROW PANEL, REFLECTORS, WARNING LIGHTS & ATTENUATOR**

BC(7)-21

FILE: bc-21.dgn	DWG: TxDOT	CHK: TxDOT	APP: TxDOT	CRK: TxDOT
©TxDOT November 2002	CONT	SECT	JOB	HIGHWAY
REVISIONS:	1603	03	042	FM 1709
9-07 8-14	DIST	COUNTY	SHEET NO.	
7-13 5-21	FTW	TARRANT	017	

DATE: FILE:

DISCLAIMER: The use of this standard is governed by the "Texas Engineering Practice Act". No warranty of any kind is made by TxDOT for any purpose whatsoever. TxDOT assumes no responsibility for the conversion of this standard to other formats or for incorrect results or damages resulting from its use.

**GENERAL NOTES**

- For long term stationary work zones on freeways, drums shall be used as the primary channelizing device.
- For intermediate term stationary work zones on freeways, drums should be used as the primary channelizing device but may be replaced in tangent sections by vertical panels, or 42" two-piece cones. In tangent sections, one-piece cones may be used with the approval of the Engineer but only if personnel are present on the project at all times to maintain the cones in proper position and location.
- For short term stationary work zones on freeways, drums are the preferred channelizing device but may be replaced in tapers, transitions and tangent sections by vertical panels, two-piece cones or one-piece cones as approved by the Engineer.
- Drums and all related items shall comply with the requirements of the current version of the "Texas Manual on Uniform Traffic Control Devices" (TMUTCD) and the "Compliant Work Zone Traffic Control Devices List" (CWZTCD).
- Drums, bases, and related materials shall exhibit good workmanship and shall be free from objectionable marks or defects that would adversely affect their appearance or serviceability.
- The Contractor shall have a maximum of 24 hours to replace any plastic drums identified for replacement by the Engineer/Inspector. The replacement device must be an approved device.

**GENERAL DESIGN REQUIREMENTS**

Pre-qualified plastic drums shall meet the following requirements:

- Plastic drums shall be a two-piece design; the "body" of the drum shall be the top portion and the "base" shall be the bottom.
- The body and base shall lock together in such a manner that the body separates from the base when impacted by a vehicle traveling at a speed of 20 MPH or greater but prevents accidental separation due to normal handling and/or air turbulence created by passing vehicles.
- Plastic drums shall be constructed of lightweight flexible, and deformable materials. The Contractor shall NOT use metal drums or single piece plastic drums as channelization devices or sign supports.
- Drums shall present a profile that is a minimum of 18 inches in width at the 36 inch height when viewed from any direction. The height of drum unit (body installed on base) shall be a minimum of 36 inches and a maximum of 42 inches.
- The top of the drum shall have a built-in handle for easy pickup and shall be designed to drain water and not collect debris. The handle shall have a minimum of two widely spaced 9/16 inch diameter holes to allow attachment of a warning light, warning reflector unit or approved compliant sign.
- The exterior of the drum body shall have a minimum of four alternating orange and white retroreflective circumferential stripes not less than 4 inches nor greater than 8 inches in width. Any non-reflectORIZED space between any two adjacent stripes shall not exceed 2 inches in width.
- Bases shall have a maximum width of 36 inches, a maximum height of 4 inches, and a minimum of two footholds of sufficient size to allow base to be held down while separating the drum body from the base.
- Plastic drums shall be constructed of ultra-violet stabilized, orange, high-density polyethylene (HDPE) or other approved material.
- Drum body shall have a maximum unballasted weight of 11 lbs.
- Drum and base shall be marked with manufacturer's name and model number.

**RETROREFLECTIVE SHEETING**

- The stripes used on drums shall be constructed of sheeting meeting the color and retroreflectivity requirements of Departmental Materials Specification DMS-8300, "Sign Face Materials." Type A or Type B reflective sheeting shall be supplied unless otherwise specified in the plans.
- The sheeting shall be suitable for use on and shall adhere to the drum surface such that, upon vehicular impact, the sheeting shall remain adhered in-place and exhibit no delaminating, cracking, or loss of retroreflectivity other than that loss due to abrasion of the sheeting surface.

**BALLAST**

- Unballasted bases shall be large enough to hold up to 50 lbs. of sand. This base, when filled with the ballast material, should weigh between 35 lbs (minimum) and 50 lbs (maximum). The ballast may be sand in one to three sandbags separate from the base, sand in a sand-filled plastic base, or other ballasting devices as approved by the Engineer. Stacking of sandbags will be allowed, however height of sandbags above pavement surface may not exceed 12 inches.
- Bases with built-in ballast shall weigh between 40 lbs. and 50 lbs. Built-in ballast can be constructed of an integral crumb rubber base or a solid rubber base.
- Recycled truck tire sidewalls may be used for ballast on drums approved for this type of ballast on the CWZTCD list.
- The ballast shall not be heavy objects, water, or any material that would become hazardous to motorists, pedestrians, or workers when the drum is struck by a vehicle.
- When used in regions susceptible to freezing, drums shall have drainage holes in the bottoms so that water will not collect and freeze becoming a hazard when struck by a vehicle.
- Ballast shall not be placed on top of drums.
- Adhesives may be used to secure base of drums to pavement.

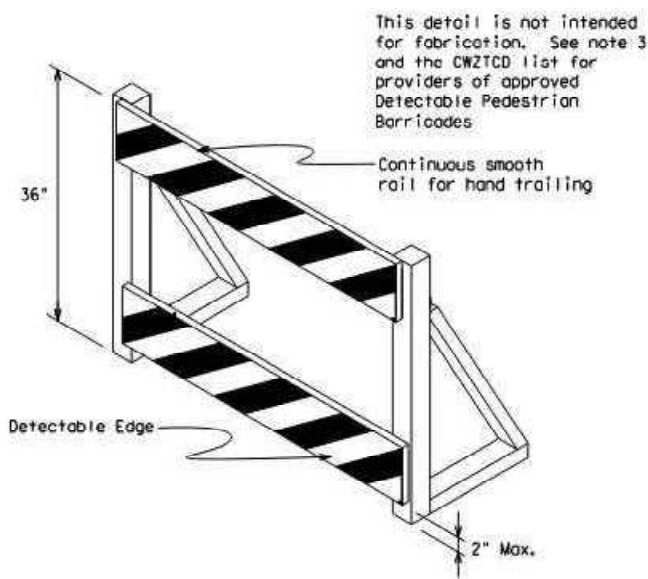
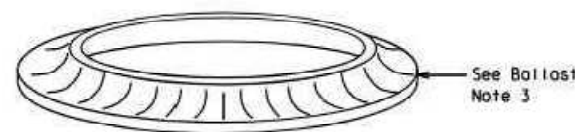
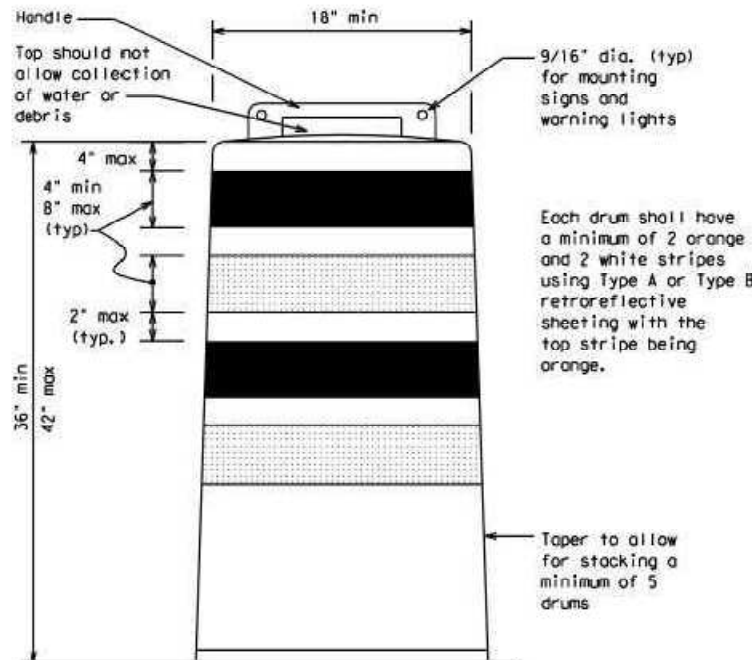

**DETECTABLE PEDESTRIAN BARRICADES**

- When existing pedestrian facilities are disrupted, closed, or relocated in a TTC zone, the temporary facilities shall be detectable and include accessibility features consistent with the features present in the existing pedestrian facility. Refer to WZ(BTS-2) for Pedestrian Control requirements for Sidewalk Diversions, Sidewalk Detours and Crosswalk Closures.
- Where pedestrians with visual disabilities normally use the closed sidewalk, a Detectable Pedestrian Barricade shall be placed across the full width of the closed sidewalk instead of a Type 3 Barricade.
- Detectable pedestrian barricades similar to the one pictured above, longitudinal channelizing devices, some concrete barriers, and wood or chain link fencing with a continuous detectable edging can satisfactorily delineate a pedestrian path.
- Tape, rope, or plastic chain strung between devices are not detectable, do not comply with the design standards in the "Americans with Disabilities Act Accessibility Guidelines (ADAAG)" and should not be used as a control for pedestrian movements.
- Warning lights shall not be attached to detectable pedestrian barricades.
- Detectable pedestrian barricades should use 8" nominal barricade rails as shown on BC(10) provided that the top rail provides a smooth continuous rail suitable for hand trailing with no splinters, burrs, or sharp edges.

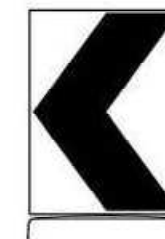

18" x 24" Sign  
(Maximum Sign Dimension)  
Chevron CWI-8, Opposing Traffic Lane  
Divider, Driveway sign D70a, Keep Right  
R4 series or other signs as approved  
by Engineer



12" x 24"  
Vertical Panel  
mount with diagonals  
sloping down towards  
travel way

Plywood, Aluminum or Metal sign  
substrates shall NOT be used on  
plastic drums

**SIGNS, CHEVRONS, AND VERTICAL PANELS MOUNTED ON PLASTIC DRUMS**

- Signs used on plastic drums shall be manufactured using substrates listed on the CWZTCD.
- Chevrons and other work zone signs with an orange background shall be manufactured with Type B<sub>FL</sub> or Type C<sub>FL</sub> Orange sheeting meeting the color and retroreflectivity requirements of DMS-8300, "Sign Face Material," unless otherwise specified in the plans.
- Vertical Panels shall be manufactured with orange and white sheeting meeting the requirements of DMS-8300 Type A or Type B. Diagonal stripes on Vertical Panels shall slope down toward the intended traveled lane.
- Other sign messages (text or symbolic) may be used as approved by the Engineer. Sign dimensions shall not exceed 18 inches in width or 24 inches in height, except for the R9 series signs discussed in note 8 below.
- Signs shall be installed using a 1/2 inch bolt (nominal) and nut, two washers, and one locking washer for each connection.
- Mounting bolts and nuts shall be fully engaged and adequately torqued. Bolts should not extend more than 1/2 inch beyond nuts.
- Chevrons may be placed on drums on the outside of curves, on merging tapers or on shifting tapers. When used in these locations, they may be placed on every drum or spaced not more than on every third drum. A minimum of three (3) should be used at each location called for in the plans.
- R9-9, R9-10, R9-11 and R9-11a Sidewalk Closed signs which are 24 inches wide may be mounted on plastic drums, with approval of the Engineer.

SHEET 8 OF 12

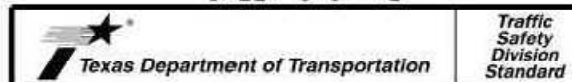

**BARRICADE AND CONSTRUCTION CHANNELIZING DEVICES**

**BC (8) - 21**

FILE: bc-21.dgn	DATE: TxDOT	DATE: TxDOT	DATE: TxDOT	DATE: TxDOT
© TxDOT November 2002	CONF: 1603	SECT: 03	JOB: 042	HIGHWAY: FM 1709
REVISIONS:				
4-03 8-14				
9-07 5-21				
7-13				
	FTW		TARRANT	SHEET NO. 018

DATE: FILE:

DISCLAIMER: This standard is governed by the "Texas Engineering Practice Act". No warranty of any kind is made by TxDOT for any purpose whatsoever. TxDOT assumes no responsibility for the conversion of this standard to other formats or for incorrect results or damages resulting from its use.

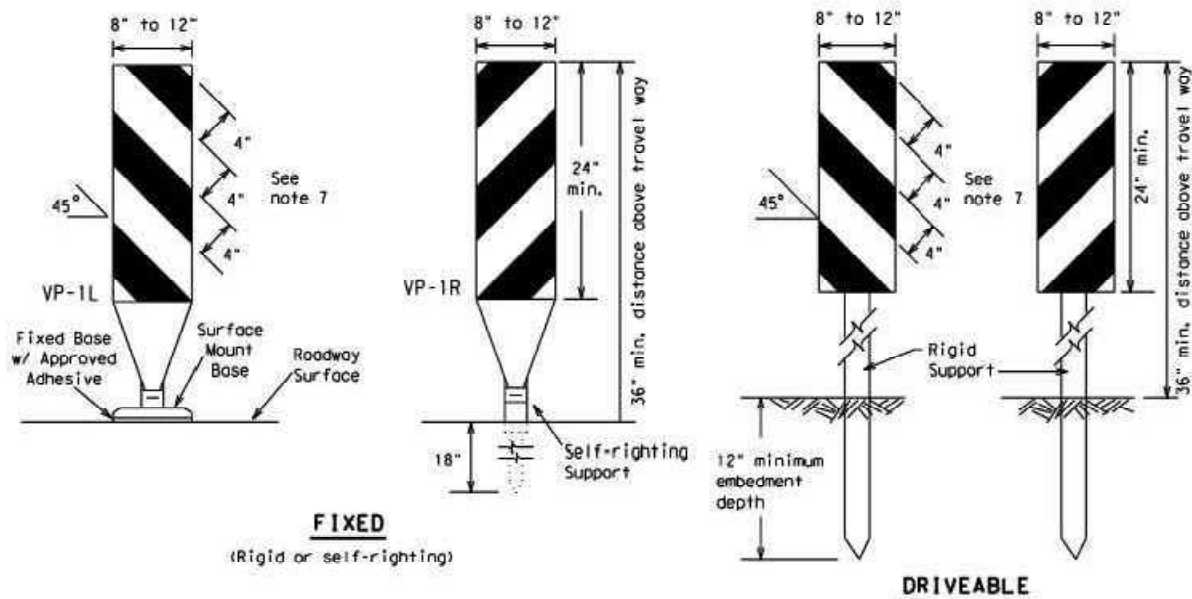

**FIXED**  
(Rigid or self-righting)

**DRIVEABLE**

- Vertical Panels (VP's) are normally used to channelize traffic or divide opposing lanes of traffic.
- VP's may be used in daytime or nighttime situations. They may be used at the edge of shoulder drop-offs and other areas such as lane transitions where positive daytime and nighttime delineation is required. The Engineer/Inspector shall refer to the Roadway Design Manual for additional requirements on the use VP's for drop-offs.
- VP's should be mounted back to back if used at the edge of cuts adjacent to two-way two lane roadways. Stripes are to be reflective orange and reflective white and should always slope downward toward the travel lane.
- VP's used on expressways and freeways or other high speed roadways, may have more than 270 square inches of retroreflective area facing traffic.
- Self-righting supports are available with portable base. See "Compliant Work Zone Traffic Control Devices List" (CWZTCD).
- Sheeting for the VP's shall be retroreflective Type A or Type B conforming to Departmental Material Specification DMS-8300, unless noted otherwise.
- Where the height of reflective material on the vertical panel is 36 inches or greater, a panel stripe of 6 inches shall be used.

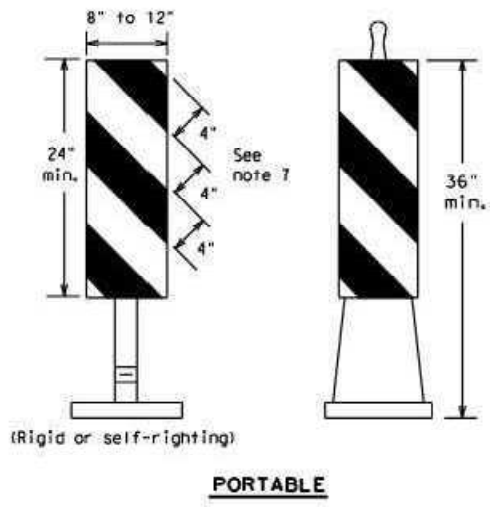

**PORTABLE**

**VERTICAL PANELS (VPs)**

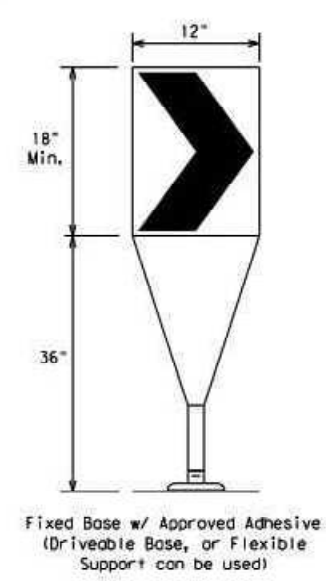

Fixed Base w/ Approved Adhesive (Driveable Base, or Flexible Support can be used)

- The chevron shall be a vertical rectangle with a minimum size of 12 by 18 inches.
- Chevrons are intended to give notice of a sharp change of alignment with the direction of travel and provide additional emphasis and guidance for vehicle operators with regard to changes in horizontal alignment of the roadway.
- Chevrons, when used, shall be erected on the outside of a sharp curve or turn, or on the far side of an intersection. They shall be in line with and at right angles to approaching traffic. Spacing should be such that the motorist always has three in view, until the change in alignment eliminates its need.
- To be effective, the chevron should be visible for at least 500 feet.
- Chevrons shall be orange with a black nonreflective legend. Sheeting for the chevron shall be retroreflective Type B<sub>FL</sub> or Type C<sub>FL</sub> conforming to Departmental Material Specification DMS-8300, unless noted otherwise. The legend shall meet the requirements of DMS-8300.
- For Long Term Stationary use on tapers or transitions on freeways and divided highways, self-righting chevrons may be used to supplement plastic drums but not to replace plastic drums.

**CHEVRONS**

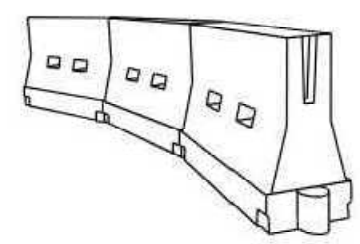

**LONGITUDINAL CHANNELIZING DEVICES (LCD)**

- LCDs are crashworthy, lightweight, deformable devices that are highly visible, have good target value and can be connected together. They are not designed to contain or redirect a vehicle on impact.
- LCDs may be used instead of a line of cones or drums.
- LCDs shall be placed in accordance to application and installation requirements specific to the device, and used only when shown on the CWZTCD list.
- LCDs should not be used to provide positive protection for obstacles, pedestrians or workers.
- LCDs shall be supplemented with retroreflective delineation as required for temporary barriers on BC(7) when placed roughly parallel to the travel lanes.
- LCDs used as barricades placed perpendicular to traffic should have at least one row of reflective sheeting meeting the requirements for barricade rolls as shown on BC(10). Place reflective sheeting near the top of the LCD along the full length of the device.

**WATER BALLASTED SYSTEMS USED AS BARRIERS**

- Water ballasted systems used as barriers shall not be used solely to channelize road users, but also to protect the work space per the appropriate Manual for Assessing Safety Hardware (MASH) crashworthiness requirements based on roadway speed and barrier application.
- Water ballasted systems used to channelize vehicular traffic shall be supplemented with retroreflective delineation or channelizing devices to improve daytime/nighttime visibility. They may also be supplemented with pavement markings.
- Water ballasted systems used as barriers shall be placed in accordance to application and installation requirements specific to the device, and used only when shown on the CWZTCD list.
- Water ballasted systems used as barriers should not be used for a merging taper except in low speed (less than 45 MPH) urban areas. When used on a taper in a low speed urban area, the taper shall be delineated and the taper length should be designed to optimize road user operations considering the available geometric conditions.
- When water ballasted systems used as barriers have blunt ends exposed to traffic, they should be attenuated as per manufacturer recommendations or flared to a point outside the clear zone.

If used to channelize pedestrians, longitudinal channelizing devices or water ballasted systems must have a continuous detectable bottom for users of long cones and the top of the unit shall not be less than 32 inches in height.

**HOLLOW OR WATER BALLASTED SYSTEMS USED AS LONGITUDINAL CHANNELIZING DEVICES OR BARRIERS**

**GENERAL NOTES**

- Work Zone channelizing devices illustrated on this sheet may be installed in close proximity to traffic and are suitable for use on high or low speed roadways. The Engineer/Inspector shall ensure that spacing and placement is uniform and in accordance with the "Texas Manual on Uniform Traffic Control Devices" (TMUTCD).
- Channelizing devices shown on this sheet may have a driveable, fixed or portable base. The requirement for self-righting channelizing devices must be specified in the General Notes or other plan sheets.
- Channelizing devices on self-righting supports should be used in work zone areas where channelizing devices are frequently impacted by errant vehicles or vehicle related wind gusts making alignment of the channelizing devices difficult to maintain. Locations of these devices shall be detailed elsewhere in the plans. These devices shall conform to the TMUTCD and the "Compliant Work Zone Traffic Control Devices List" (CWZTCD).
- The Contractor shall maintain devices in a clean condition and replace damaged, nonreflective, faded, or broken devices and bases as required by the Engineer/Inspector. The Contractor shall be required to maintain proper device spacing and alignment.
- Portable bases shall be fabricated from virgin and/or recycled rubber. The portable bases shall weigh a minimum of 30 lbs.
- Pavement surfaces shall be prepared in a manner that ensures proper bonding between the adhesives, the fixed mount bases and the pavement surface. Adhesives shall be prepared and applied according to the manufacturer's recommendations.
- The installation and removal of channelizing devices shall not cause detrimental effects to the final pavement surfaces, including pavement surface discoloration or surface integrity. Driveable bases shall not be permitted on final pavement surfaces. The Engineer/Inspector shall approve all application and removal procedures of fixed bases.

Posted Speed	Formula	Minimum Desirable Taper Lengths			Suggested Maximum Spacing of Channelizing Devices	
		10' Offset	11' Offset	12' Offset	On a Taper	On a Tangent
30	L = WS <sup>2</sup> / 60	150'	165'	180'	30'	60'
35		205'	225'	245'	35'	70'
40		265'	295'	320'	40'	80'
45	L = WS	450'	495'	540'	45'	90'
50		500'	550'	600'	50'	100'
55		550'	605'	660'	55'	110'
60		600'	660'	720'	60'	120'
65		650'	715'	780'	65'	130'
70		700'	770'	840'	70'	140'
75		750'	825'	900'	75'	150'
80		800'	880'	960'	80'	160'

\*\*Taper lengths have been rounded off.  
L=Length of Taper (FT.) W=Width of Offset (FT.)  
S=Posted Speed (MPH)

**SUGGESTED MAXIMUM SPACING OF CHANNELIZING DEVICES AND MINIMUM DESIRABLE TAPER LENGTHS**

SHEET 9 OF 12

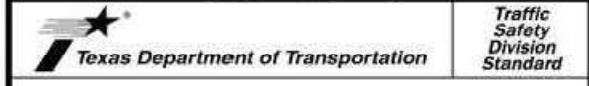

**BARRICADE AND CONSTRUCTION CHANNELIZING DEVICES**

BC (9) - 21

FILE: bc-21.dgn	DWG: TxDOT	CHK: TxDOT	APP: TxDOT	CRK: TxDOT
© TxDOT November 2002	CONT: 1603	SECT: 03	JOB: 042	HIGHWAY: FM 1709
REVISIONS:	DATE:	BY:	CHK:	APP:
9-07 8-14				
7-13 5-21				
	DIST: FTW	COUNTY: TARRANT	SHEET NO.: 019	

DATE: FILE:

**OPPOSING TRAFFIC LANE DIVIDERS (OTLD)**

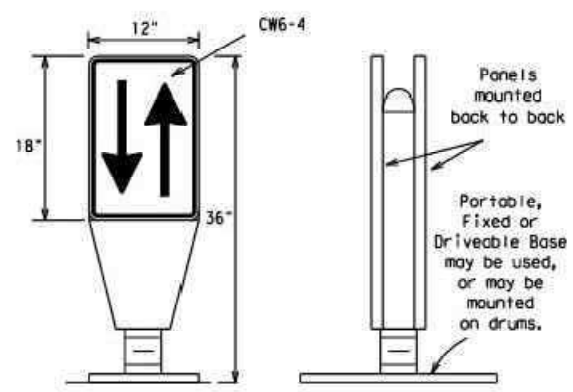

- Opposing Traffic Lane Dividers (OTLD) are delineation devices designed to convert a normal one-way roadway section to two-way operation. OTLD's are used on temporary centerlines. The upward and downward arrows on the sign's face indicate the direction of traffic on either side of the divider. The base is secured to the pavement with an adhesive or rubber weight to minimize movement caused by a vehicle impact or wind gust.
- The OTLD may be used in combination with 42" cones or VPs.
- Spacing between the OTLD shall not exceed 500 feet. 42" cones or VPs placed between the OTLD's should not exceed 100 foot spacing.
- The OTLD shall be orange with a black non-reflective legend. Sheeting for the OTLD shall be retroreflective Type B<sub>FL</sub> or Type C<sub>FL</sub> conforming to Departmental Material Specification DMS-8300, unless noted otherwise. The legend shall meet the requirements of DMS-8300.

Panels mounted back to back  
Portable, Fixed or Driveable Base may be used, or may be mounted on drums.



## WORK ZONE PAVEMENT MARKINGS

### GENERAL

- The Contractor shall be responsible for maintaining work zone and existing pavement markings, in accordance with the standard specifications and special provisions, on all roadways open to traffic within the CSJ limits unless otherwise stated in the plans.
- Color, patterns and dimensions shall be in conformance with the "Texas Manual on Uniform Traffic Control Devices" (TMUTCD).
- Additional supplemental pavement marking details may be found in the plans or specifications.
- Pavement markings shall be installed in accordance with the TMUTCD and as shown on the plans.
- When short term markings are required on the plans, short term markings shall conform with the TMUTCD, the plans and details as shown on the Standard Plan Sheet WZ(STPM).
- When standard pavement markings are not in place and the roadway is opened to traffic, DO NOT PASS signs shall be erected to mark the beginning of the sections where passing is prohibited and PASS WITH CARE signs at the beginning of sections where passing is permitted.
- All work zone pavement markings shall be installed in accordance with Item 662, "Work Zone Pavement Markings."

### RAISED PAVEMENT MARKERS

- Raised pavement markers are to be placed according to the patterns on BC(12).
- All raised pavement markers used for work zone markings shall meet the requirements of Item 672, "RAISED PAVEMENT MARKERS" and Departmental Material Specification DMS-4200 or DMS-4300.

### PREFABRICATED PAVEMENT MARKINGS

- Removable prefabricated pavement markings shall meet the requirements of DMS-8241.
- Non-removable prefabricated pavement markings (foil back) shall meet the requirements of DMS-8240.

### MAINTAINING WORK ZONE PAVEMENT MARKINGS

- The Contractor will be responsible for maintaining work zone pavement markings within the work limits.
- Work zone pavement markings shall be inspected in accordance with the frequency and reporting requirements of work zone traffic control device inspections as required by Form 599.
- The markings should provide a visible reference for a minimum distance of 300 feet during normal daylight hours and 160 feet when illuminated by automobile low-beam headlights at night, unless sight distance is restricted by roadway geometrics.
- Markings failing to meet this criteria within the first 30 days after placement shall be replaced at the expense of the Contractor as per Specification Item 662.

### REMOVAL OF PAVEMENT MARKINGS

- Pavement markings that are no longer applicable, could create confusion or direct a motorist toward or into the closed portion of the roadway shall be removed or obliterated before the roadway is opened to traffic.
- The above shall not apply to detours in place for less than three days, where flaggers and/or sufficient channelizing devices are used in lieu of markings to outline the detour route.
- Pavement markings shall be removed to the fullest extent possible, so as not to leave a discernable marking. This shall be by any method approved by TxDOT Specification Item 677 for "Eliminating Existing Pavement Markings and Markers".
- The removal of pavement markings may require resurfacing or seal coating portions of the roadway as described in Item 677.
- Subject to the approval of the Engineer, any method that proves to be successful on a particular type pavement may be used.
- Blast cleaning may be used but will not be required unless specifically shown in the plans.
- Over-painting of the markings SHALL NOT BE permitted.
- Removal of raised pavement markers shall be as directed by the Engineer.
- Removal of existing pavement markings and markers will be paid for directly in accordance with Item 677, "ELIMINATING EXISTING PAVEMENT MARKINGS AND MARKERS," unless otherwise stated in the plans.
- Black-out marking tape may be used to cover conflicting existing markings for periods less than two weeks when approved by the Engineer.

## Temporary Flexible-Reflective Roadway Marker Tabs

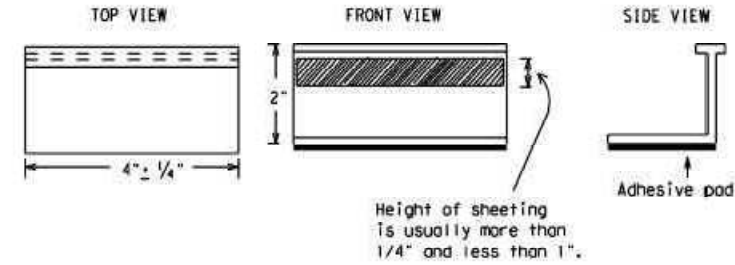

**STAPLES OR NAILS SHALL NOT BE USED TO SECURE  
TEMPORARY FLEXIBLE-REFLECTIVE ROADWAY MARKER  
TABS TO THE PAVEMENT SURFACE**

- Temporary flexible-reflective roadway marker tabs used as guidemarks shall meet the requirements of DMS-8242.
- Tabs detailed on this sheet are to be inspected and accepted by the Engineer or designated representative. Sampling and testing is not normally required, however at the option of the Engineer, either "A" or "B" below may be imposed to assure quality before placement on the roadway.
  - Select five (5) or more tabs at random from each lot or shipment and submit to the Construction Division, Materials and Pavement Section to determine specification compliance.
  - Select five (5) tabs and perform the following test. Affix five (5) tabs at 24 inch intervals on an asphaltic pavement in a straight line. Using a medium size passenger vehicle or pickup, run over the markers with the front and rear tires at a speed of 35 to 40 miles per hour, four (4) times in each direction. No more than one (1) out of the five (5) reflective surfaces shall be lost or displaced as a result of this test.
- Small design variances may be noted between tab manufacturers.
- See Standard Sheet WZ(STPM) for tab placement on new pavements. See Standard Sheet TCP(7-1) for tab placement on seal coat work.

### RAISED PAVEMENT MARKERS USED AS GUIDEMARKS

- Raised pavement markers used as guidemarks shall be from the approved product list, and meet the requirements of DMS-4200.
- All temporary construction raised pavement markers provided on a project shall be of the same manufacturer.
- Adhesive for guidemarks shall be bituminous material hot applied or butyl rubber pad for all surfaces, or thermoplastic for concrete surfaces.

Guidemarks shall be designated as:

- YELLOW - (two amber reflective surfaces with yellow body).
- WHITE - (one silver reflective surface with white body).

DEPARTMENTAL MATERIAL SPECIFICATIONS	
PAVEMENT MARKERS (REFLECTORIZED)	DMS-4200
TRAFFIC BUTTONS	DMS-4300
EPOXY AND ADHESIVES	DMS-6100
BITUMINOUS ADHESIVE FOR PAVEMENT MARKERS	DMS-6130
PERMANENT PREFABRICATED PAVEMENT MARKINGS	DMS-8240
TEMPORARY REMOVABLE, PREFABRICATED PAVEMENT MARKINGS	DMS-8241
TEMPORARY FLEXIBLE, REFLECTIVE ROADWAY MARKER TABS	DMS-8242

A list of prequalified reflective raised pavement markers, non-reflective traffic buttons, roadway marker tabs and other pavement markings can be found at the Material Producer List web address shown on BC(1).

SHEET 11 OF 12



## BARRICADE AND CONSTRUCTION PAVEMENT MARKINGS

**BC(11)-21**

FILE: bc-21.dgn	DN: TxDOT	CK: TxDOT	EN: TxDOT	CR: TxDOT
©TxDOT February 1998	CONT	SECT	JOB	HIGHWAY
REVISIONS:	1603	03	042	FM 1709
2-98 9-07 5-21	DISP	COUNTY	SHEET NO.	
1-02 7-13	FTW	TARRANT	021	
11-02 8-14				

DISCLAIMER: The use of this standard is governed by the "Texas Engineering Practice Act". No warranty of any kind is made by TxDOT for any purpose whatsoever. TxDOT assumes no responsibility for the conversion of this standard to other formats or for incorrect results or damages resulting from its use.

DATE: FILE:



## PAVEMENT MARKING PATTERNS



REFLECTORIZED PAVEMENT MARKINGS - PATTERN A

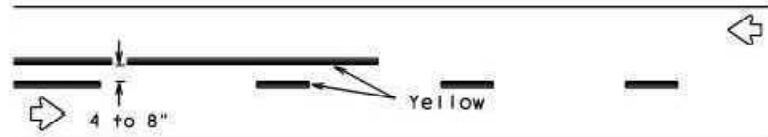

REFLECTORIZED PAVEMENT MARKINGS - PATTERN B

Pattern A is the TxDOT Standard, however Pattern B may be used if approved by the Engineer. Prefabricated markings may be substituted for reflectORIZED pavement markings.

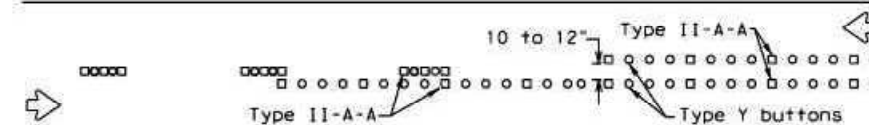

RAISED PAVEMENT MARKERS - PATTERN A

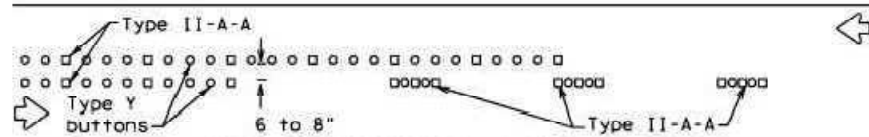

RAISED PAVEMENT MARKERS - PATTERN B

## CENTER LINE & NO-PASSING ZONE BARRIER LINES FOR TWO-LANE, TWO-WAY HIGHWAYS

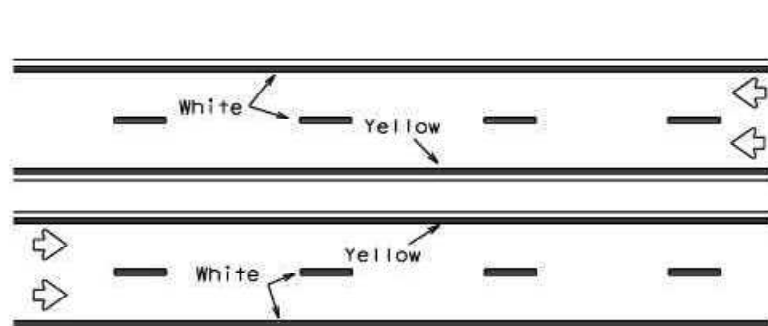

REFLECTORIZED PAVEMENT MARKINGS

Prefabricated markings may be substituted for reflectORIZED pavement markings.

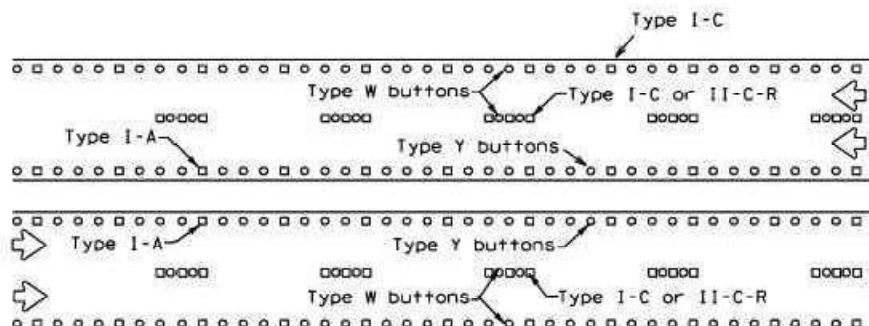

RAISED PAVEMENT MARKERS

## EDGE & LANE LINES FOR DIVIDED HIGHWAY

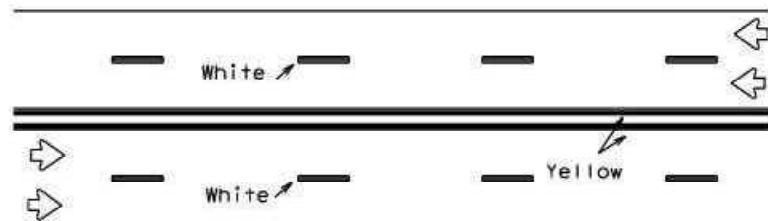

REFLECTORIZED PAVEMENT MARKINGS

Prefabricated markings may be substituted for reflectORIZED pavement markings.

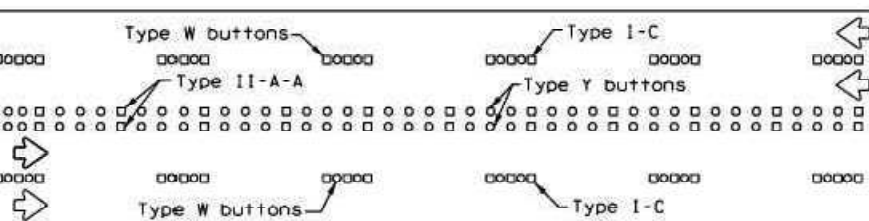

RAISED PAVEMENT MARKERS

## LANE & CENTER LINES FOR MULTILANE UNDIVIDED HIGHWAYS

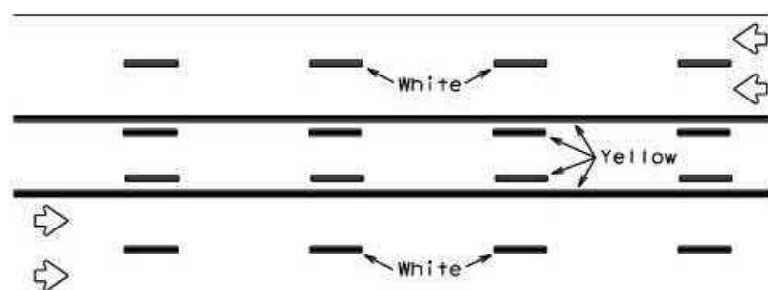

REFLECTORIZED PAVEMENT MARKINGS

Prefabricated markings may be substituted for reflectORIZED pavement markings.

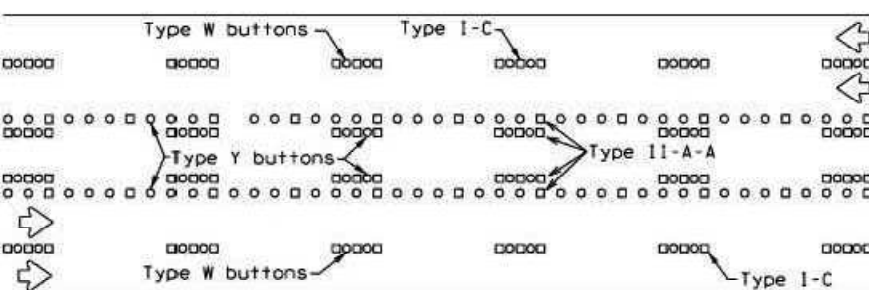

RAISED PAVEMENT MARKERS

## TWO-WAY LEFT TURN LANE

## STANDARD WORK ZONE PAVEMENT MARKINGS DETAILS

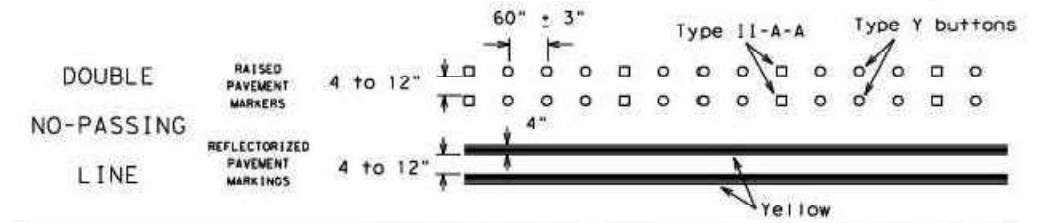

SOLID LINES

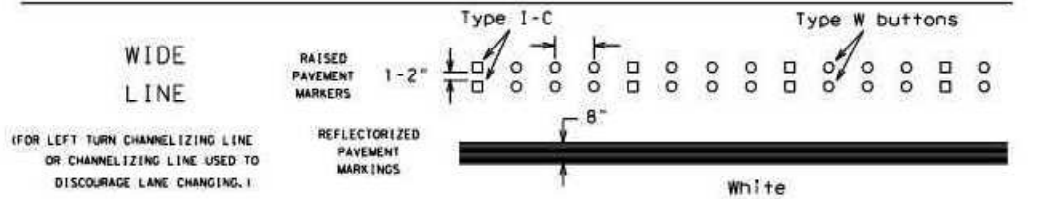
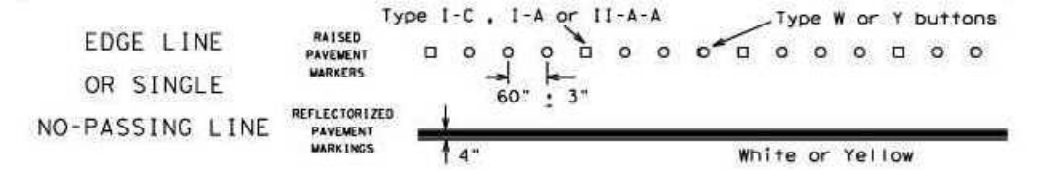

BROKEN LINES

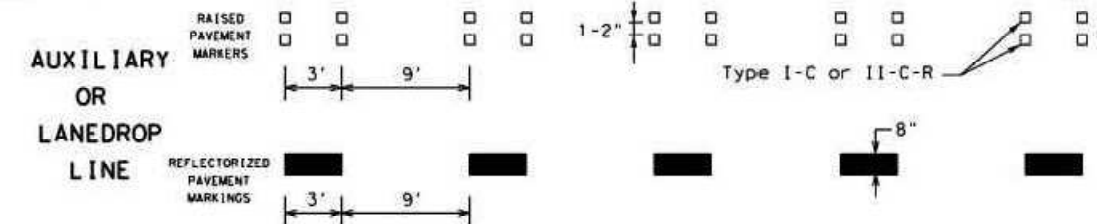
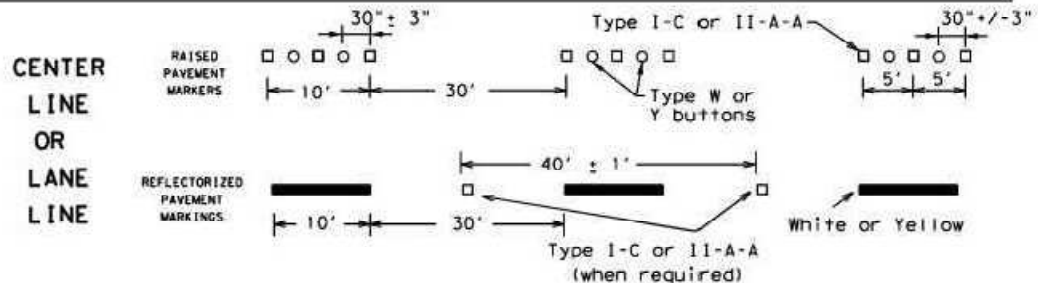

## REMOVABLE MARKINGS WITH RAISED PAVEMENT MARKERS

If raised pavement markers are used to supplement REMOVABLE markings, the markers shall be applied to the top of the tape at the approximate mid length of tape used for broken lines or at 20 foot spacing for solid lines. This allows an easier removal of raised pavement markers and tape.

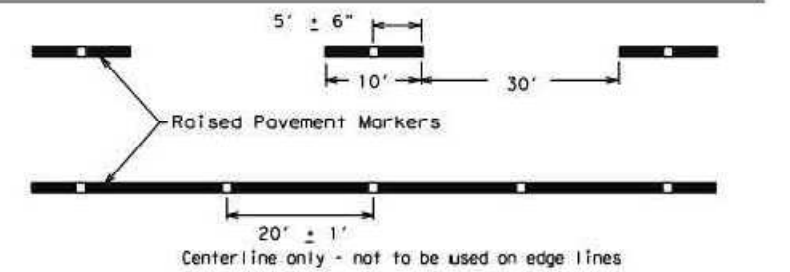

SHEET 12 OF 12



## BARRICADE AND CONSTRUCTION PAVEMENT MARKING PATTERNS

BC (12) - 21

FILE: bc-21.dgn	DATE: TxDOT	BY: TxDOT	DATE: TxDOT	BY: TxDOT
© TxDOT February 1998	CONT	SECT	JOB	HIGHWAY
1-97 9-07 5-21	1603	03	042	FM 1709
2-98 7-13	DIST	COUNTY	SHEET NO.	
11-02 8-14	FTW	TARRANT	022	

Raised pavement markers used as standard pavement markings shall be from the approved products list and meet the requirements of Item 672 "RAISED PAVEMENT MARKERS."

DISCLAIMER: The use of this standard is governed by the "Texas Engineering Practice Act". No warranty of any kind is made by TxDOT for any purpose whatsoever. TxDOT assumes no responsibility for the conversion of this standard to other formats or for incorrect results or damages resulting from its use.

DATE: FILE:

# DEFINITION OF TREATMENT ZONES FOR VARIOUS EDGE CONDITIONS

Edge Height (D) in Inches versus Lateral Clearance (Y) in Feet

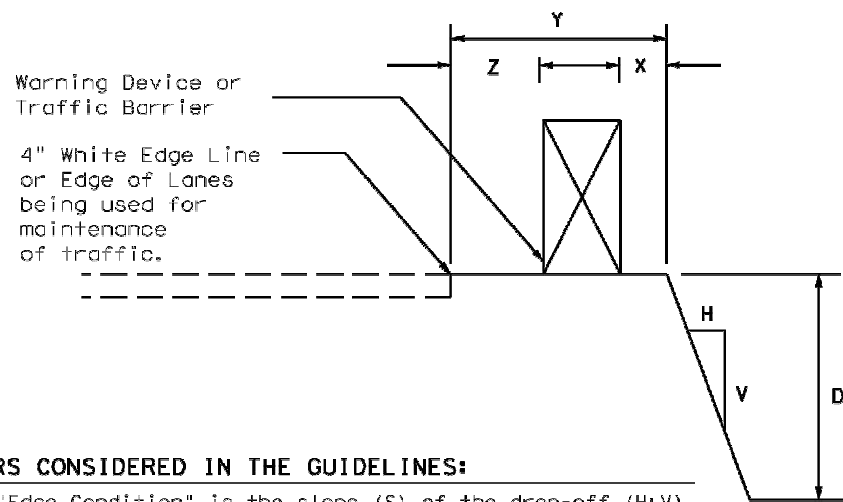
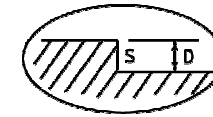
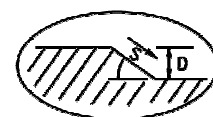
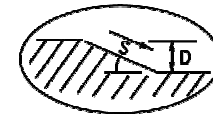
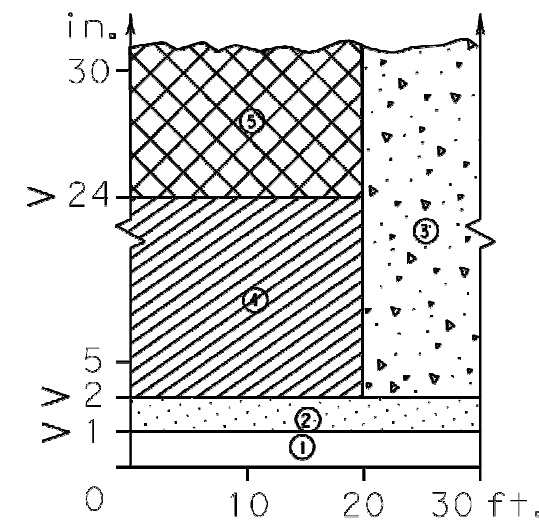
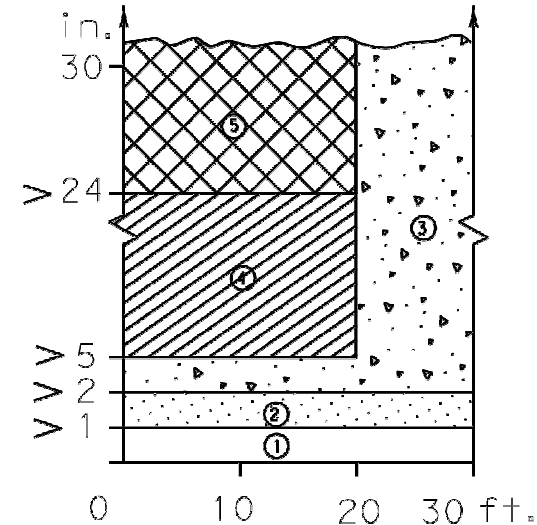
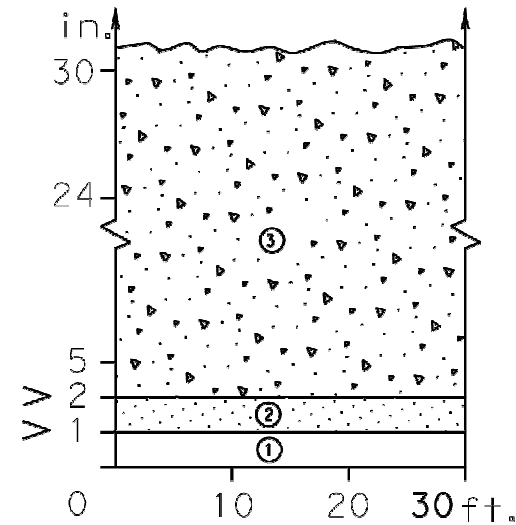

Zone	Treatment Types Guidelines:
①	No treatment
②	CW 8-11 "Uneven Lanes" signs.
③	CW 8-9a Shoulder Drop-Off" or CW 8-11 signs plus vertical panels.
④	CW8-9a or CW 8-11, signs plus drums. Where restricted space precludes the use of drums, use vertical panels. An edge slope to that of the preferred Edge Condition I.
⑤	Check indications (Figure-1) for positive barrier. Where positive barrier is not indicated, the treatment shown above for Zone-4 may be used after consideration of other applicable factors.

### Edge Condition Notes:

- Edge Condition I: Most vehicles are able to traverse an edge condition with a slope rate of (3 to 1) or flatter. The slope must be constructed with a compacted material capable of supporting vehicles.
- Edge Condition II: Most vehicles are able to traverse an edge condition with a slope between (2.99 to 1) and (1 to 1) so long as "D" does not exceed 5 inches. Under-carriage drag on most automobiles will occur when "D" exceeds 6 inches. As "D" exceeds 24 inches, the possibility for rollover is greater in most vehicles.
- Edge Condition III: When slopes are greater than (1 to 1) and where "D" is greater than 2 inches, a more difficult control factor may exist for some vehicles, if not properly treated. For example, where "D" is greater than 2 inches and up to 24 inches different types of vehicles may experience different steering control at different edge heights. Automobiles might experience more steering control differential when "D" is greater than 2 inches and up to 5 inches. Trucks, particularly those with high loads, have more steering control differential when "D" is greater than 5 inches and up to 24 inches. When "D" exceeds 24 inches, the possibility of rollover is greater for most vehicles.
- Milling or overlay operations that result in Edge Condition III should not be in place without appropriate warning treatments, and these conditions should not be left in place for extended periods of time.

# FIGURE-1: CONDITIONS INDICATING USE OF POSITIVE BARRIER FOR ZONE 5 ( [Cross-hatched] )

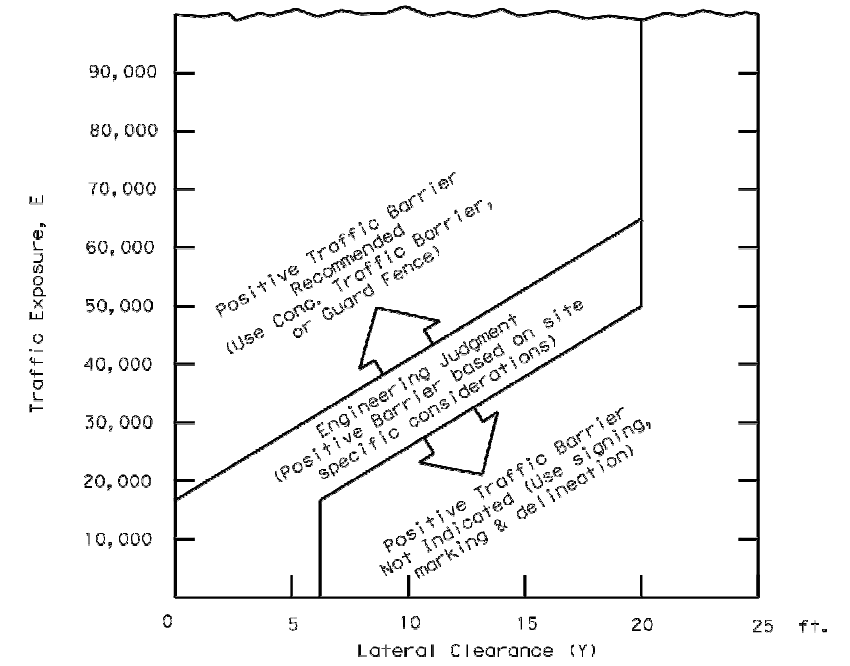

- $E = ADT \times T$   
Where ADT is that portion of the average daily traffic volume traveling within 20 feet (generally two adjacent lanes) of the edge dropoff condition; and, T is the duration time in years of the dropoff condition.
- Figure-1 provides a practical approach to the use of positive barriers for the protection of vehicles from pavement drop-offs. Other factors, such as the presence of heavy machinery, construction workers, or the mix and volume of traffic may make the use of positive barriers appropriate, even when the edge condition alone may not justify the use of a barrier.
- An approved end treatment should be provided for any positive barrier end located within the clear zone.

These guidelines apply to temporary traffic control areas or work zones where continuous pavement edges or drop-offs exists parallel and adjacent to a lane used by traffic. The edge conditions may be present between shoulders and travel lanes, between adjacent or opposing travel lanes, or at intermediate points across the width of the paved surface. Due to the variability in construction operations, tolerances in the variables may be allowed by the engineer. These guidelines do not apply to short term operations. These guidelines do not constitute a rigid standard or policy; rather, they are guidance to be used in conjunction with engineering judgement. These guidelines may be updated on the Design Division's on-line manuals.

Engineer's Seal

Date: 04/05/2024

Texas Department of Transportation

Traffic Safety Division Standard

## TREATMENT FOR VARIOUS EDGE CONDITIONS

FILE: edgecon.dgn	DWG: TxDOT	CHK: TxDOT	DES: TxDOT	CRK: TxDOT
© TxDOT August 2000	CONT: 1603	SECT: 03	JOB: 042	HIGHWAY: FM 1709
REVISIONS	DIST: FTW	COUNTY: TARRANT	SHEET NO.: 023	

DISCLAIMER: The use of this standard is governed by the "Texas Engineering Practice Act". No warranty of any kind is made by TxDOT for any purpose whatsoever. TxDOT assumes no responsibility for the conversion of this standard to other formats or for incorrect results or damages resulting from its use.

**TRAFFIC CONTROL NOTES**

FOLLOW STANDARD TCP SHEETS FOR LANE CLOSURES.

PLACE WORK ZONE PAVEMENT MARKINGS IN ACCORDANCE WITH WZ(STPM)-13.

SIGN AND TREAT EDGE CONDITIONS IN ACCORDANCE WITH WZ(UL)-13 AND TXDOT STANDARD, "WORKSHEET FOR EDGE CONDITION TREATMENT TYPES" (WECTT)

PLACE REMOVABLE WORK ZONE PAVEMENT MARKINGS IN ACCORDANCE WITH BC(11)-14 & BC(12)-14 ON FINAL SURFACES



CWB-11



CWB-15

PLACE IN ACCORDANCE WITH SHEETS WECTT, WZ (UL)-13, BC's, AND/OR AS DIRECTED.



CWB-17

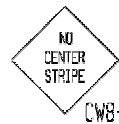

CWB-12

UNLESS OTHERWISE SHOWN ALL CW SIGNS SHALL BE 48" X 48".

**SEQUENCE OF WORK**

TCP PHASE I-STAGE 1

1. PLACE PROJECT ADVANCED SIGNS
2. REFERENCE EXISTING PAVEMENT MARKINGS
3. PLACE NECESSARY EROSION CONTROL DEVICES
4. CONSTRUCT COLLEGE AVENUE TO CINDY STREET FROM STA 03+00 TO STA 17+00.

**CONSTRUCTION NOTES:**

- \*CONTRACTOR SHALL MEASURE AND RECORD ALL PAVEMENT MARKINGS PRIOR TO CONSTRUCTION
- \*CONTRACTOR SHALL MEASURE AND RECORD EXISTING CROSS SLOPES.
- \*CONTRACTOR SHALL MAINTAIN EXISTING GRADES AND SLOPES EXCEPT AS SHOWN OR AS DIRECTED AND PERFORM WORK IN A WAY TO ELIMINATE THE TRAPPING OF WATER AND ALLOW PROPER DRAINAGE.
- \*CONTRACTOR SHALL CREATED TAPERED FEATHERED BUTT JOINTS TO ALLOW A TRANSITIONED A RAMPED GRADE CHANGE AT END OF WORKING SHIFTS AND PRIOR TO OPENING UP TRAFFIC
- \*TEMPORARY STRIPING OPERATIONS TO BE COMPLETED DAILY
- \*PLACE PAVEMENT MARKINGS AND MARKERS IN THE SAME MANNER EXISTING PRIOR TO CONSTRUCTION
- \*REMOVE TRAFFIC CONTROL DEVICES, CONSTRUCTION DEBRIS AND EROSION CONTROL DEVICES



**TRAFFIC CONTROL & SEQUENCE OF WORK**

D.D. BY		PROJECT NO.	SHEET NO.
DIV. NO.			
1709	F2B24(139)	024	
STATE	STATE DIST. NO.	COUNTY	
TEXAS	FTW	TARRANT	
CONT.	SECT.	JOB	HIGHWAY NO.
1603	03	042	FM 1709

PLOTTED BY: PRESLEY, LAURA  
 PLOT DATE: 5/6/2024 2:29 PM  
 LOCATION: K:\FTW\_LALP\061097030\_KELLER GREEN RIBBON PH II\DWG\04 CD\SHEET\4 - HARDSCAPE PLANDWG  
 LAST SAVED: 3/20/2024 6:43 PM

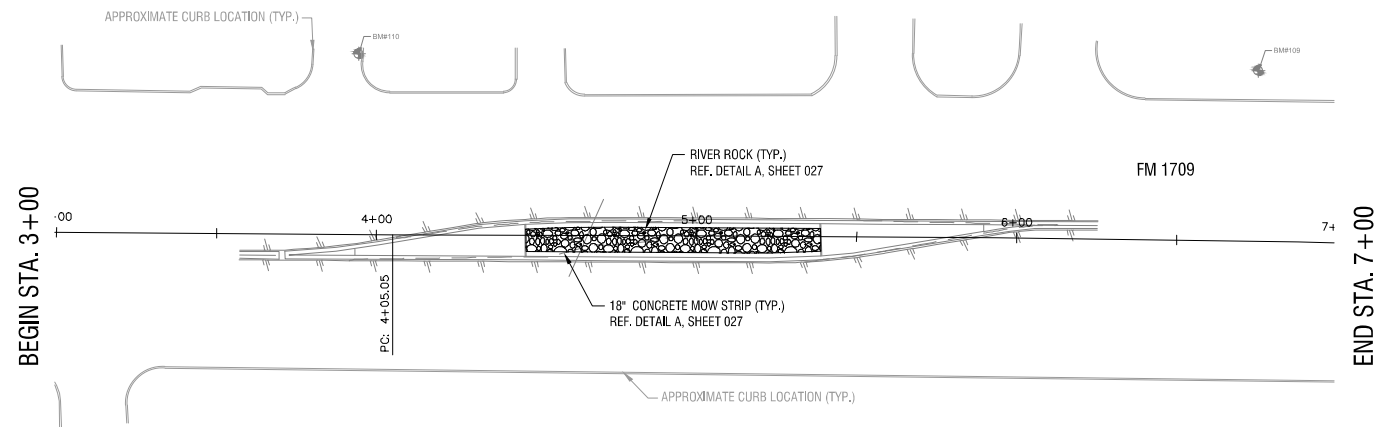

**A** BEGIN STA. 3+00 TO END STA. 7+00  
 PLAN

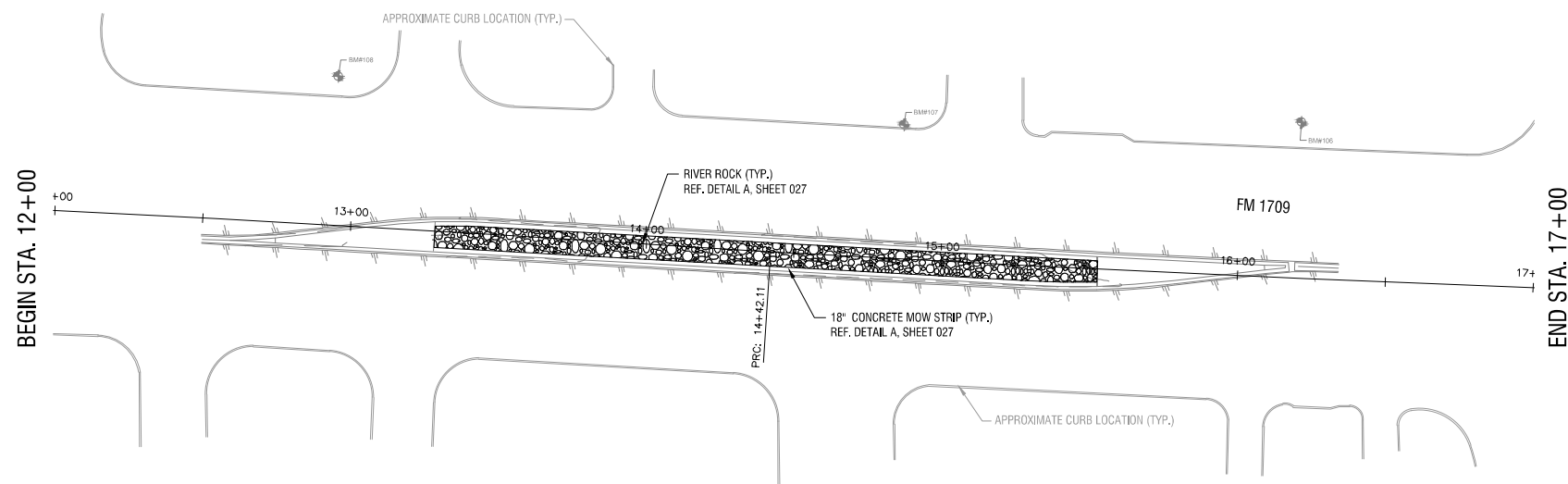

**B** BEGIN STA. 12+00 TO END STA. 17+00  
 PLAN

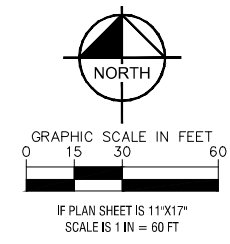

**CAUTION!**  
 EXISTING UNDERGROUND UTILITIES IN THE AREA  
 CONTRACTOR IS RESPONSIBLE FOR DETERMINING THE  
 HORIZONTAL AND VERTICAL LOCATION OF ALL UTILITIES  
 PRIOR TO CONSTRUCTION. CONTRACTOR SHALL BE  
 RESPONSIBLE FOR ANY REPAIRS TO EXISTING UTILITIES  
 DUE TO DAMAGE INCURRED DURING CONSTRUCTION.  
 CONTRACTOR SHALL IMMEDIATELY NOTIFY THE ENGINEER  
 OF ANY DISCREPANCIES ON THE PLANS.



04/05/2024

**Kimley Horn**

® Texas Registered Engineering Firm F-928

Texas Department of Transportation  
 © 2024

**KELLER FM 1709 LANDSCAPE  
 ENHANCEMENTS  
 GREEN RIBBON PROGRAM PHASE II  
 KELLER, TEXAS**

**HARDSCAPE PLAN  
 STA. 3+00 TO STA. 7+00  
 STA. 12+00 TO STA. 17+00**

FED.RD.	PROJECT NO.	HIGHWAY NO.
FM 1709	SEE TITLE SHEET	FM 1709
STATE	DISTRICT	COUNTY
TEXAS	FTW	TARRANT
CONTROL	SECTION	JOB
1603	03	042
SHEET NO.		
025		

PLOTTED BY: PRESLEY, LAURA  
 PLOT DATE: 5/6/2024 2:29 PM  
 LOCATION: K:\FTW\_LALP\061097030\_KELLER GREEN RIBBON PH II\DWG\04 CD\SHEET\4 - HARDSCAPE PLANDWG  
 LAST SAVED: 3/20/2024 6:43 PM

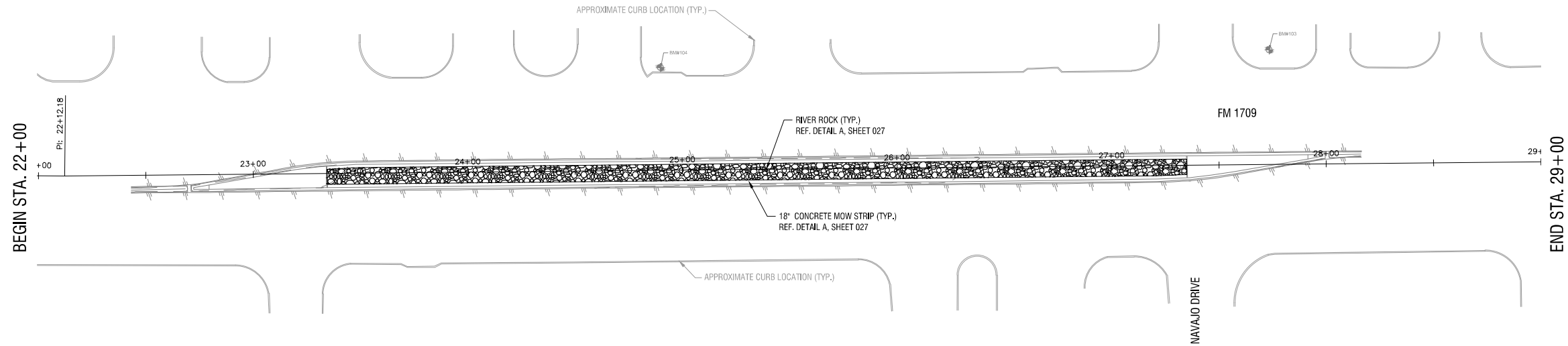

BEGIN STA. 22+00

END STA. 29+00

FM 1709

NAVAJO DRIVE

C ALTERNATE BID: BEGIN STA. 22+00 TO END STA. 29+00  
 PLAN

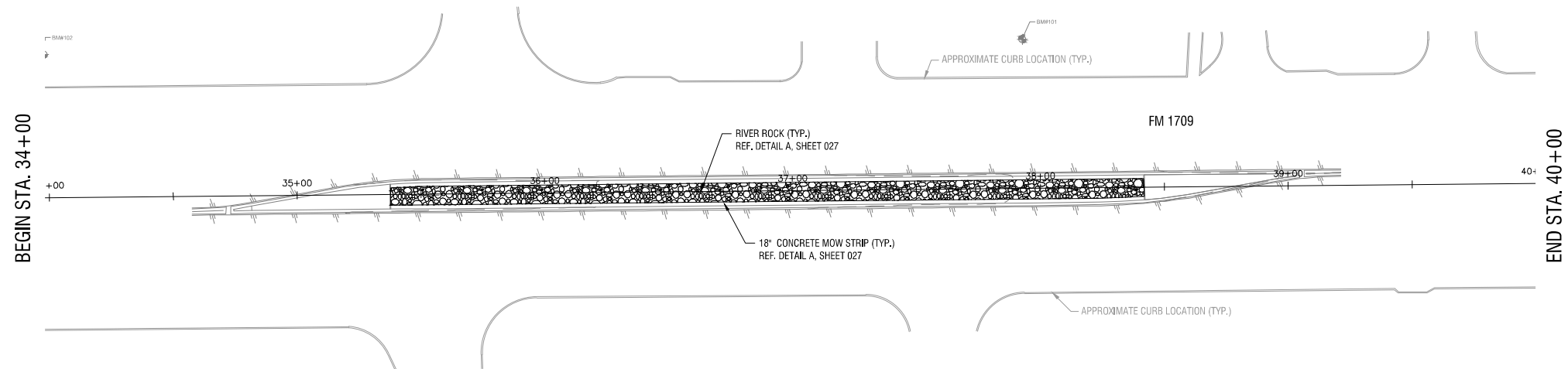

BEGIN STA. 34+00

END STA. 40+00

FM 1709

D ALTERNATE BID: BEGIN STA. 34+00 TO END STA. 40+00  
 PLAN

**CAUTION!**  
 EXISTING UNDERGROUND UTILITIES IN THE AREA  
 CONTRACTOR IS RESPONSIBLE FOR DETERMINING THE  
 HORIZONTAL AND VERTICAL LOCATION OF ALL UTILITIES  
 PRIOR TO CONSTRUCTION. CONTRACTOR SHALL BE  
 RESPONSIBLE FOR ANY REPAIRS TO EXISTING UTILITIES  
 DUE TO DAMAGE INCURRED DURING CONSTRUCTION.  
 CONTRACTOR SHALL IMMEDIATELY NOTIFY THE ENGINEER  
 OF ANY DISCREPANCIES ON THE PLANS.



04/05/2024

**Kimley Horn**

® Texas Registered Engineering Firm F-928

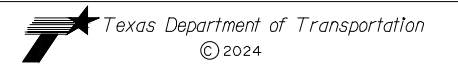

**KELLER FM 1709 LANDSCAPE  
 ENHANCEMENTS  
 GREEN RIBBON PROGRAM PHASE II  
 KELLER, TEXAS**

**HARDSCAPE PLAN  
 STA. 22+00 TO STA. 29+00  
 STA. 34+00 TO STA. 40+00**

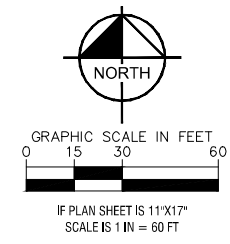

FED.RD.	PROJECT NO.	HIGHWAY NO.
FM 1709	SEE TITLE SHEET	FM 1709
STATE	DISTRICT	COUNTY
TEXAS	FTW	TARRANT
CONTROL	SECTION	JOB
1603	03	042
SHEET NO.		
026		

PLOTTED BY: PRESLEY, LAURA  
 PLOT DATE: 5/6/2024 2:29 PM  
 LOCATION: K:\FTW\_LALP\061097030\_KELLER GREEN RIBBON PH II\DWG\04 CD\SHEET\5 - HARDSCAPE DETAILS.DWG  
 LAST SAVED: 12/8/2023 2:37 PM

**A** 18" CONCRETE MOW STRIP @ RIVER ROCK  
 SECTION

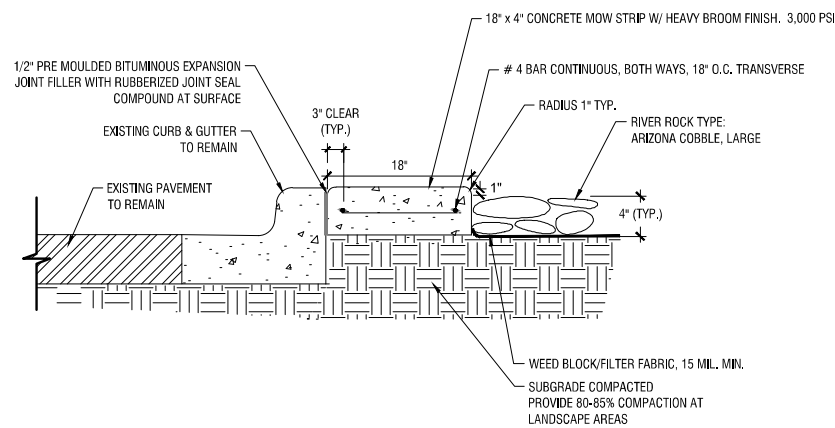

- NOTES:**
- CONTRACTOR TO SUBMIT PAVER SAMPLES FOR REVIEW AND APPROVAL PRIOR TO CONSTRUCTION.
  - CONTRACTOR TO REPAIR/REPLACE EXISTING LANDSCAPE TO ITS PREVIOUS CONDITION IF DISTURBED DURING CONSTRUCTION. FINAL APPROVAL BY DRB OR LANDSCAPE ARCHITECT.
  - PROVIDE 1/2" DEEP SAWCUTS TO MOW STRIP AT 6' O.C.
  - PROVIDE EXPANSION JOINT TO ADJACENT PAVEMENT AND/OR CURB

- NOTES:**
- CONTRACTOR TO SUBMIT RIVER ROCK SAMPLE TO CITY AND/OR LANDSCAPE ARCHITECT FOR REVIEW AND APPROVAL PRIOR TO INSTALLATION.
  - RIVER ROCK TO BE PAID FOR UNDER BID ITEM: 192 613 RIPRAP (SPECIAL).

**CAUTION!**  
 EXISTING UNDERGROUND UTILITIES IN THE AREA  
 CONTRACTOR IS RESPONSIBLE FOR DETERMINING THE  
 HORIZONTAL AND VERTICAL LOCATION OF ALL UTILITIES  
 PRIOR TO CONSTRUCTION. CONTRACTOR SHALL BE  
 RESPONSIBLE FOR ANY REPAIRS TO EXISTING UTILITIES  
 DUE TO DAMAGE INCURRED DURING CONSTRUCTION.  
 CONTRACTOR SHALL IMMEDIATELY NOTIFY THE ENGINEER  
 OF ANY DISCREPANCIES ON THE PLANS.



04/05/2024

**Kimley»Horn**  
 ® Texas Registered Engineering Firm F-928  
 Texas Department of Transportation  
 © 2024

**KELLER FM 1709 LANDSCAPE  
 ENHANCEMENTS  
 GREEN RIBBON PROGRAM PHASE II  
 KELLER, TEXAS**

**HARDSCAPE DETAILS**

FED.RD.	PROJECT NO.	HIGHWAY NO.
FM 1709	SEE TITLE SHEET	FM 1709
STATE	DISTRICT	COUNTY
TEXAS	FTW	TARRANT
CONTROL	SECTION	JOB
1603	03	042
SHEET NO.		
027		

NTS

PLOTTED BY: PRESLEY, LAURA  
 PLOT DATE: 5/6/2024 2:30 PM  
 LOCATION: K:\FTW\_LALP\061097030\_KELLER GREEN RIBBON PH II\DWG\04 CD\SHEET\6 - LANDSCAPE PLAN.DWG  
 LAST SAVED: 4/7/2024 7:13 PM

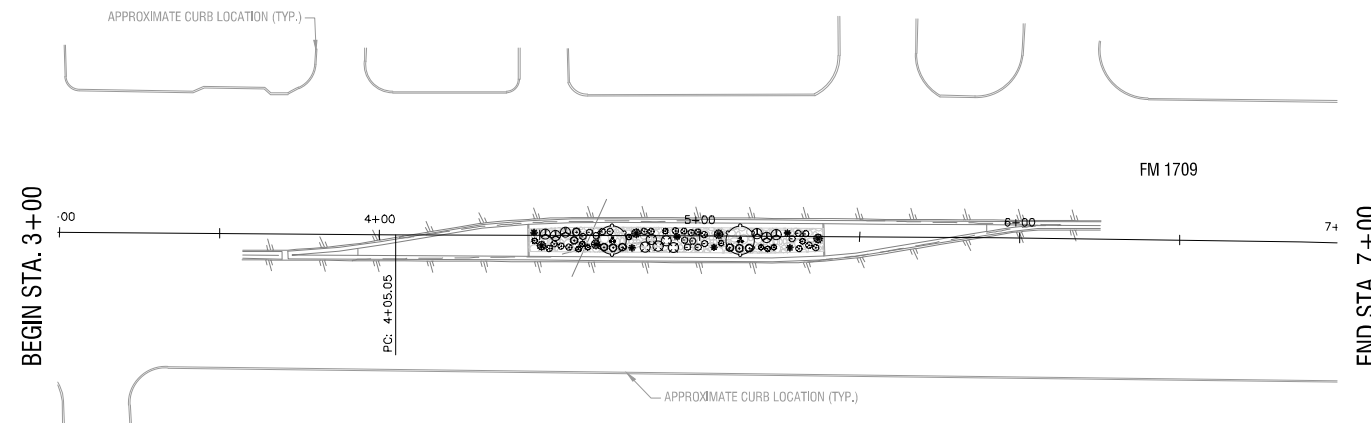

BEGIN STA. 3+00

END STA. 7+00

FM 1709

A BEGIN STA. 3+00 TO END STA. 7+00  
 PLAN

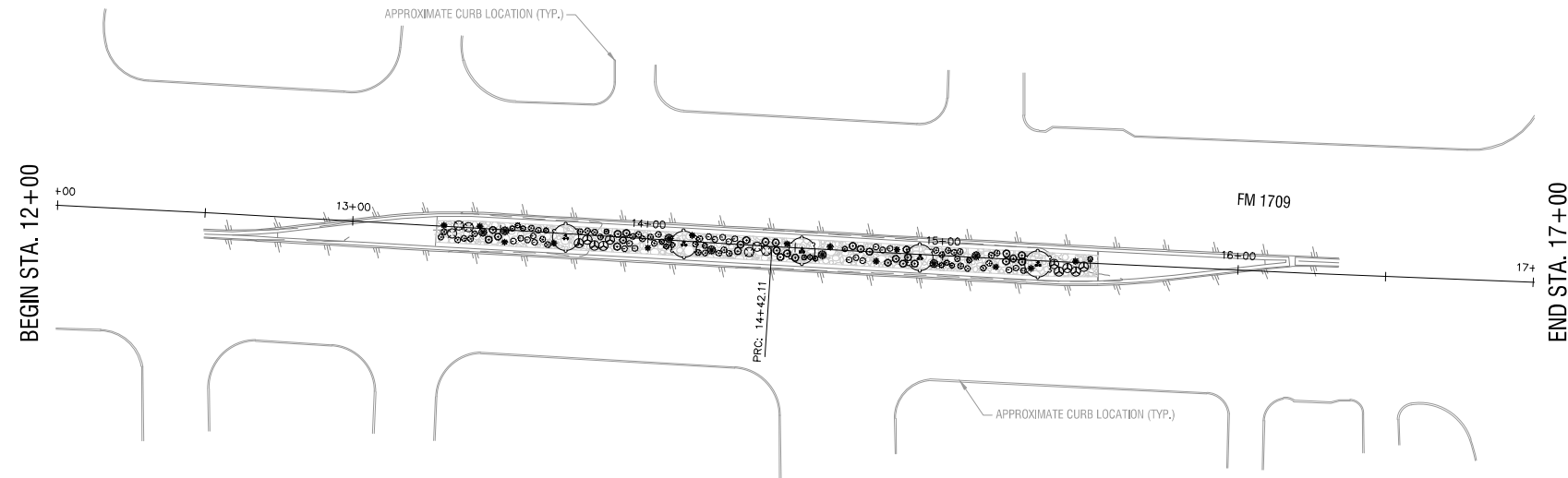

BEGIN STA. 12+00

END STA. 17+00

FM 1709

B BEGIN STA. 12+00 TO END STA. 17+00  
 PLAN

BASE BID: PLANT SCHEDULE

SYMBOL	CODE	QTY	BOTANICAL / COMMON NAME	SIZE	REMARKS
<b>ORNAMENTAL TREE</b>					
	CH	7	CHILOPSIS LINEARIS / DESERT WILLOW	6' -8' HT, 3' -4' SPR	FULL & MATCHING, MULTI-TRUNK
<b>SHRUBS</b>					
	BO	35	BERBERIS THUNBERGII 'ORANGE ROCKET' / ORANGE ROCKET JAPANESE BARBERRY	18" HT, 18" SPR, 24" OC	FULL & MATCHING, 5 GAL. MIN.
	HES	29	HESPERALOE PARVIFLORA / RED YUCCA	18" HT, 18" SPR, 24" OC	FULL & MATCHING, 5 GAL. MIN.
	LCS	11	LEUCOPHYLLUM FRUTESCENS 'COMPACTA' / COMPACT TEXAS SAGE	24" HT, 24" SPR, 36" OC	FULL & MATCHING, 5 GAL. MIN.
	NLL	16	NANDINA DOMESTICA 'LEMON-LIME' / LEMON-LIME HEAVENLY BAMBOO	30" HT, 30" SPR, 48" OC	FULL & MATCHING, 5 GAL. MIN.
	OPI	12	OPUNTIA AUREA 'TEXAS FEEDER' / SPINELESS PRICKLYPEAR	18" HT, 18" SPR, 36" OC	FULL & MATCHING, 5 GAL. MIN.
	YCA	19	YUCCA FILAMENTOSA 'COLOR GUARD' / ADAM'S NEEDLE	18" HT, 18" SPR, 24" OC	FULL & MATCHING, 5 GAL. MIN.
<b>GRASSES</b>					
	MUH	38	MUHLENBERGIA CAPILLARIS / PINK MUHLY	24" HT, 30" OC	FULL & MATCHING, 5 GAL. MIN.
	NAS	53	NASSELLA TENUISSIMA / MEXICAN FEATHER GRASS	18" HT, 24" OC	FULL & MATCHING, 5 GAL. MIN.

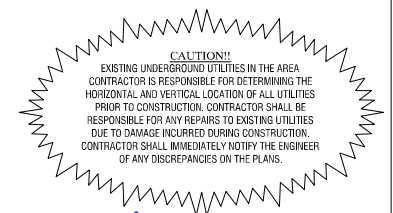

04/05/2024



® Texas Registered Engineering Firm F-928

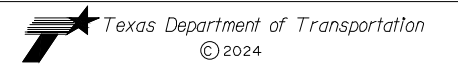

KELLER FM 1709 LANDSCAPE ENHANCEMENTS  
 GREEN RIBBON PROGRAM PHASE II  
 KELLER, TEXAS

LANDSCAPE PLAN  
 STA. 3+00 TO STA. 7+00  
 STA. 12+00 TO STA. 17+00

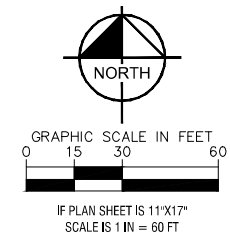

FED.RD.	PROJECT NO.	HIGHWAY NO.
FM 1709	SEE TITLE SHEET	FM 1709
STATE	DISTRICT	COUNTY
TEXAS	FTW	TARRANT
CONTROL	SECTION	JOB
1603	03	042
SHEET NO.		
028		

PLOTTED BY: PRESLEY, LAURA  
 PLOT DATE: 5/6/2024 2:30 PM  
 LOCATION: K:\FTW\_LALP\061097030\_KELLER GREEN RIBBON PH II\DWG\04 CD\SHEET\6 - LANDSCAPE PLAN.DWG  
 LAST SAVED: 4/7/2024 7:13 PM

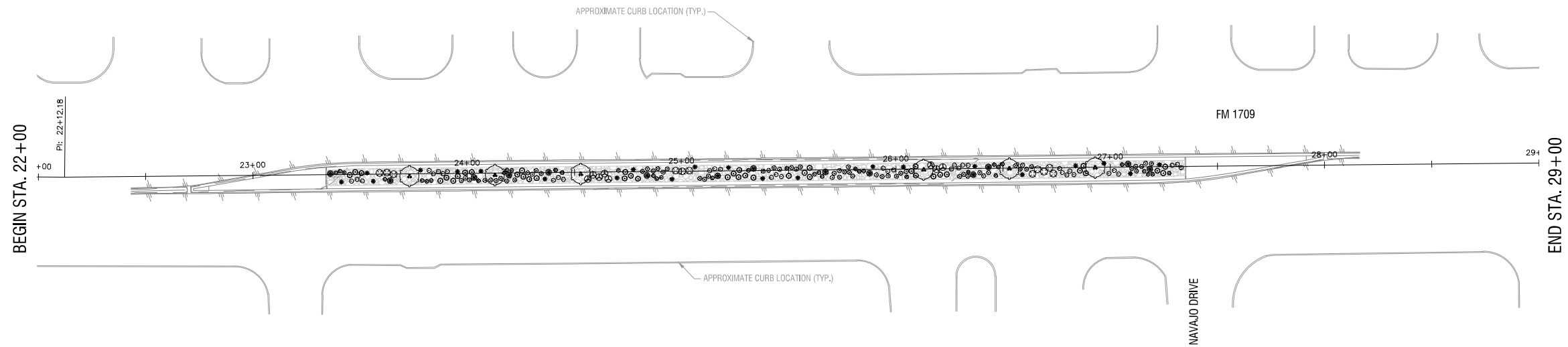

**C** ALTERNATE BID: BEGIN STA. 22+00 TO END STA. 29+00  
 PLAN

ALTERNATE BID: PLANT SCHEDULE

SYMBOL	CODE	QTY	BOTANICAL / COMMON NAME	SIZE	REMARKS
<b>ORNAMENTAL TREE</b>					
	CH	12	CHILOPSIS LINEARIS / DESERT WILLOW	6'-8" HT, 3'-4" SPR	FULL & MATCHING, MULTI-TRUNK
<b>SHRUBS</b>					
	BO	61	BERBERIS THUNBERGII 'ORANGE ROCKET' / ORANGE ROCKET JAPANESE BARBERRY	18" HT, 18" SPR, 24" OC	FULL & MATCHING, 5 GAL. MIN.
	HES	71	HESPERALOE PARVIFLORA / RED YUCCA	18" HT, 18" SPR, 24" OC	FULL & MATCHING, 5 GAL. MIN.
	LCS	24	LEUCOPHYLLUM FRUTESCENS 'COMPACTA' / COMPACT TEXAS SAGE	24" HT, 24" SPR, 36" OC	FULL & MATCHING, 5 GAL. MIN.
	NLL	14	NANDINA DOMESTICA 'LEMON-LIME' / LEMON-LIME HEAVENLY BAMBOO	30" HT, 30" SPR, 48" OC	FULL & MATCHING, 5 GAL. MIN.
	OPU	22	OPUNTIA AUREA 'TEXAS FEEDER' / SPINELESS PRICKLYPEAR	18" HT, 18" SPR, 36" OC	FULL & MATCHING, 5 GAL. MIN.
	YCA	34	YUCCA FILAMENTOSA 'COLOR GUARD' / ADAM'S NEEDLE	18" HT, 18" SPR, 24" OC	FULL & MATCHING, 5 GAL. MIN.
<b>GRASSES</b>					
	MUH	82	MUHLENBERGIA CAPILLARIS / PINK MUHLY	24" HT, 30" OC	FULL & MATCHING, 5 GAL. MIN.
	NAS	90	NASSELLA TENUISSIMA / MEXICAN FEATHER GRASS	18" HT, 24" OC	FULL & MATCHING, 5 GAL. MIN.

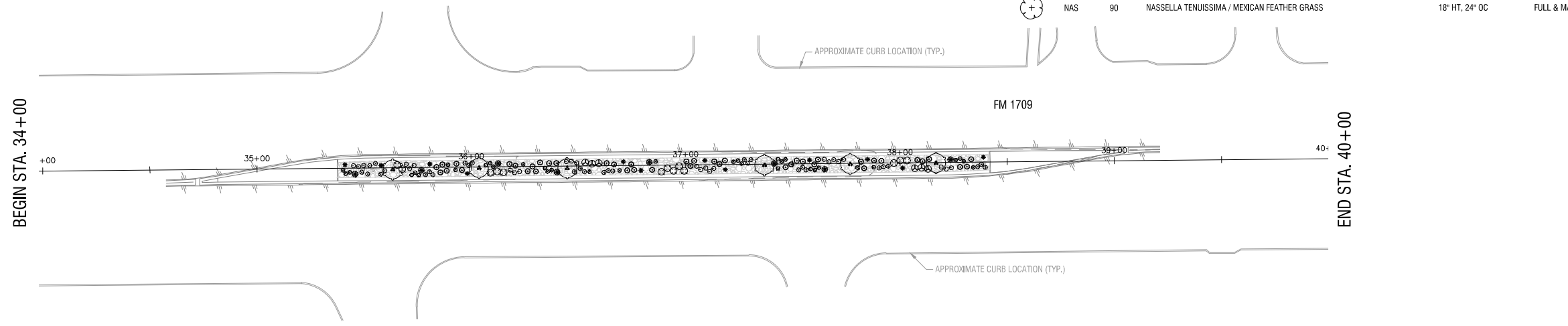

**D** ALTERNATE BID: BEGIN STA. 34+00 TO END STA. 40+00  
 PLAN

**CAUTION!**  
 EXISTING UNDERGROUND UTILITIES IN THE AREA  
 CONTRACTOR IS RESPONSIBLE FOR DETERMINING THE  
 HORIZONTAL AND VERTICAL LOCATION OF ALL UTILITIES  
 PRIOR TO CONSTRUCTION. CONTRACTOR SHALL BE  
 RESPONSIBLE FOR ANY REPAIRS TO EXISTING UTILITIES  
 DUE TO DAMAGE INCURRED DURING CONSTRUCTION.  
 CONTRACTOR SHALL IMMEDIATELY NOTIFY THE ENGINEER  
 OF ANY DISCREPANCIES ON THE PLANS.



04/05/2024

**Kimley Horn**

® Texas Registered Engineering Firm F-928  
 Texas Department of Transportation  
 © 2024

**KELLER FM 1709 LANDSCAPE  
 ENHANCEMENTS  
 GREEN RIBBON PROGRAM PHASE II  
 KELLER, TEXAS**

**LANDSCAPE PLAN  
 STA. 22+00 TO STA. 29+00  
 STA. 34+00 TO STA. 40+00**

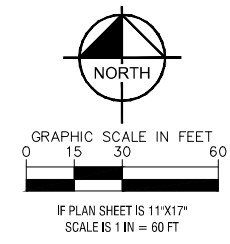

FED.RD.	PROJECT NO.	HIGHWAY NO.	
FM 1709	SEE TITLE SHEET	FM 1709	
STATE	DISTRICT	COUNTY	SHEET NO.
TEXAS	FTW	TARRANT	029
CONTROL	SECTION	JOB	
1603	03	042	



PLOTTED BY: PRESLEY, LAURA  
 PLOT DATE: 5/6/2024 2:30 PM  
 LOCATION: K:\FTW\_LALP\061097030\_KELLER GREEN RIBBON PH II\DWG\04\_CD\SHEET\7 - LANDSCAPE DETAILS.DWG  
 LAST SAVED: 12/4/2023 1:06 PM

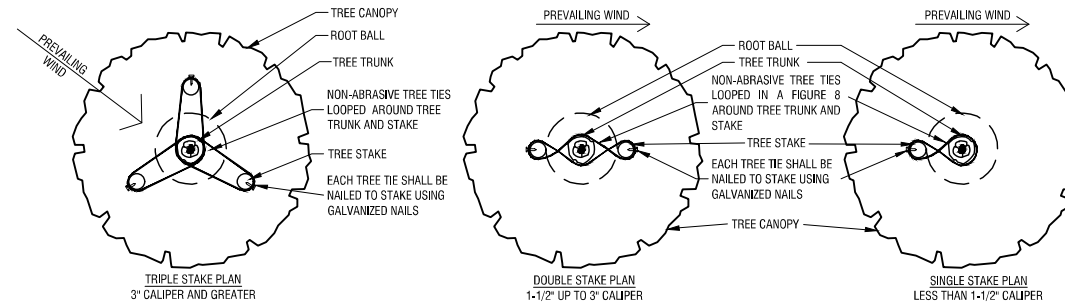

**NOTES:**  
 1. THIS DETAIL IS FOR ABOVE GRADE TREE STAKING ONLY. REF. OTHER DETAILS FOR TYPICAL TREE PLANTING.

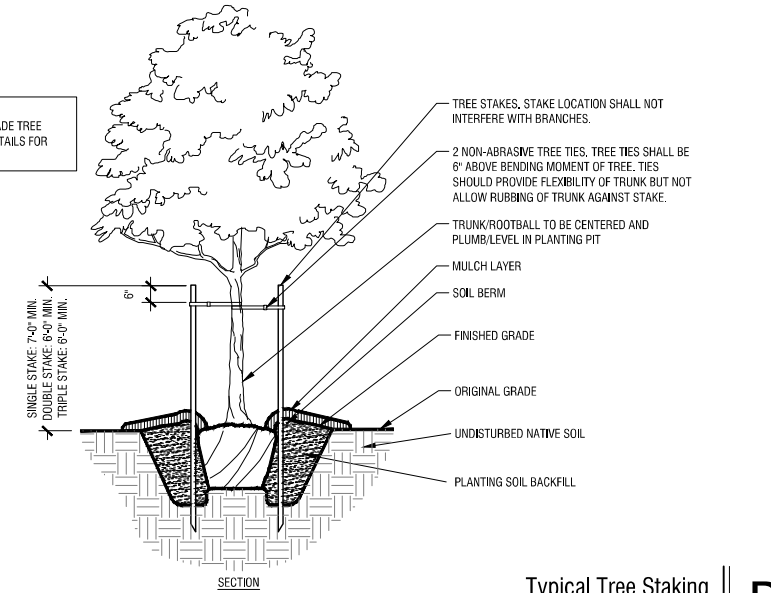

Typical Tree Staking

Scale: NTS

**B**

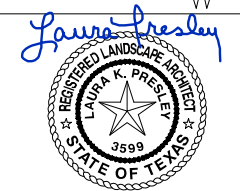
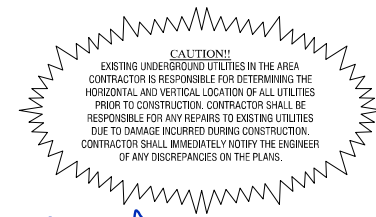

04/05/2024

**Kimley Horn**

® Texas Registered Engineering Firm F-928



**KELLER FM 1709 LANDSCAPE ENHANCEMENTS GREEN RIBBON PROGRAM PHASE II**  
 KELLER, TEXAS

**LANDSCAPE DETAILS**

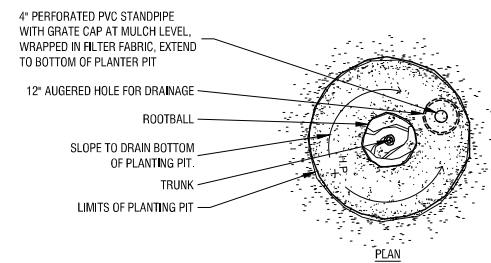

**NOTES:**  
 1. THIS DETAIL IS FOR TREE PLANTING IN POOR DRAINAGE CONDITIONS ONLY. REF. DETAIL A THIS SHEET FOR TYPICAL TREE PLANTING.

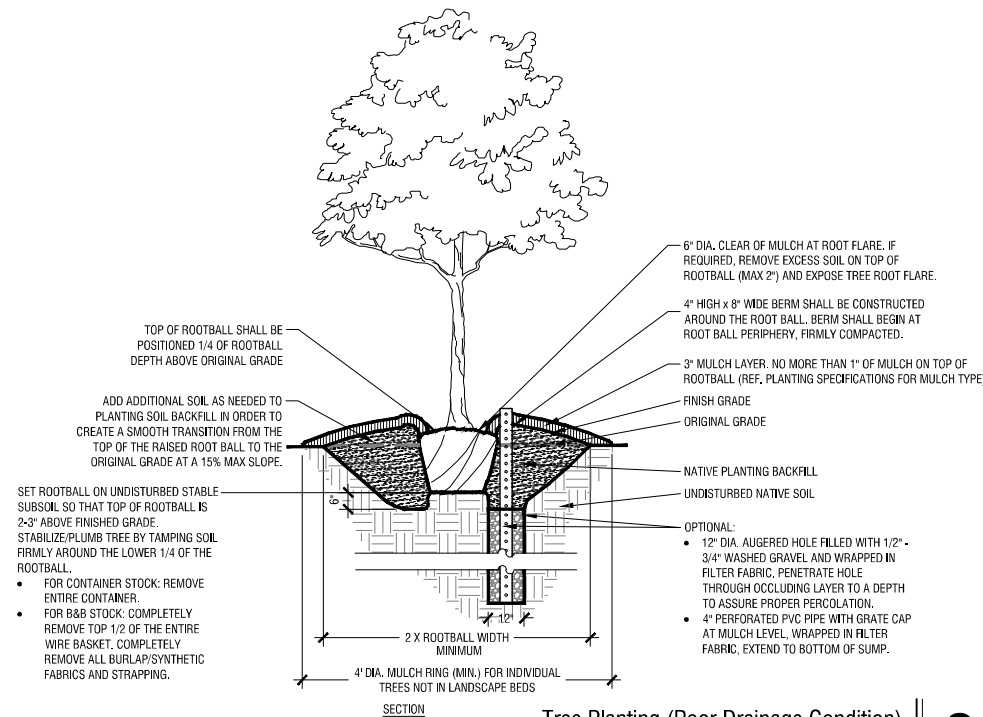

Tree Planting (Poor Drainage Condition)

Scale: NTS

**C**

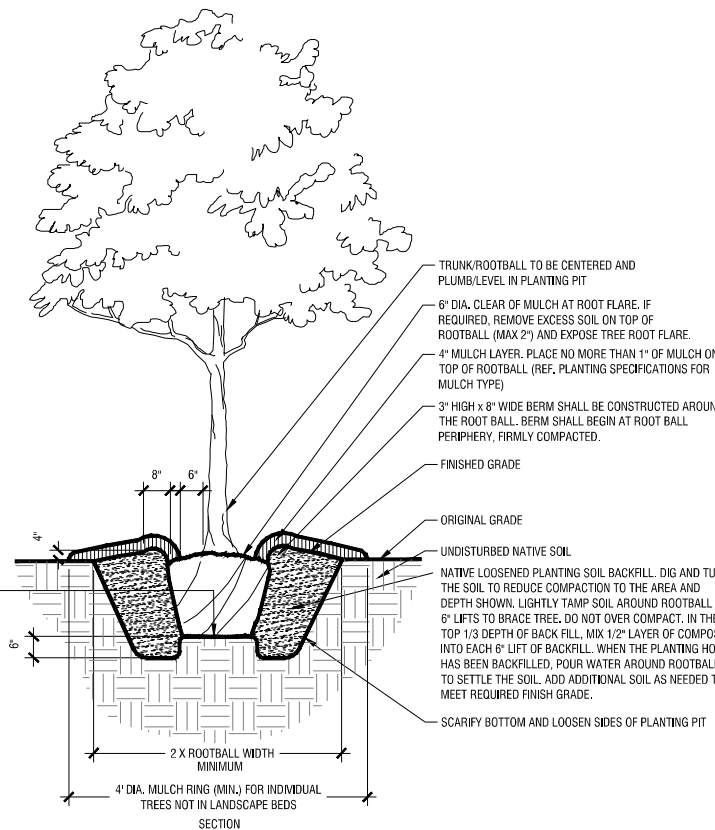

Typical Tree Planting (Up to 3\"/>

Scale: NTS

**A**

FED.RD.	PROJECT NO.	HIGHWAY NO.
FM 1709	SEE TITLE SHEET	FM 1709
STATE	DISTRICT	COUNTY
TEXAS	FTW	TARRANT
CONTROL	SECTION	JOB
1603	03	042

SHEET NO. 030

PLOTTED BY: PRESLEY, LAURA  
 PLOT DATE: 5/6/2024 2:31 PM  
 LOCATION: K:\FTW\_LALP\061097030\_KELLER GREEN RIBBON PH II\DWG\04 CD\SHEET\7 - LANDSCAPE DETAILS.DWG  
 LAST SAVED: 12/4/2023 1:06 PM

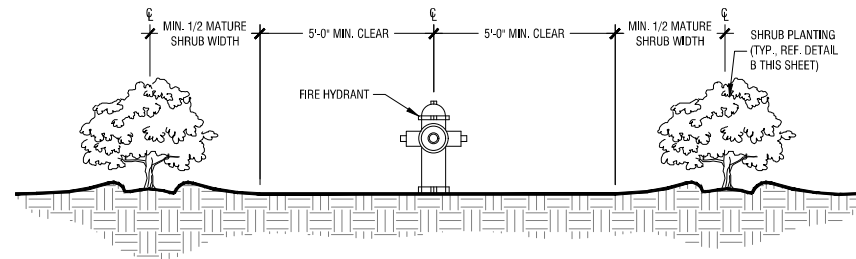

**E** Shrub Planting at Fire Hydrant

Scale: NTS

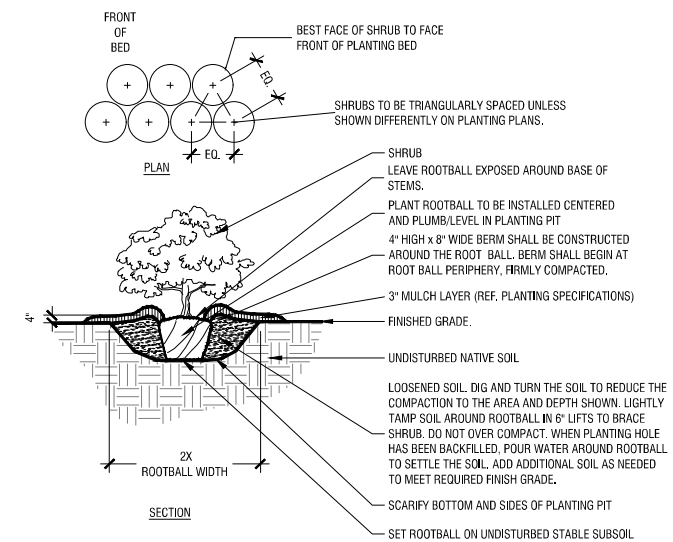

**B** Typical Shrub Planting

Scale: NTS

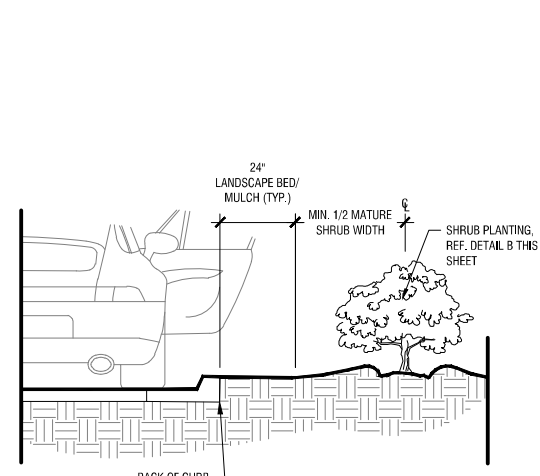

**F** Shrub Planting at Curb

Scale: NTS

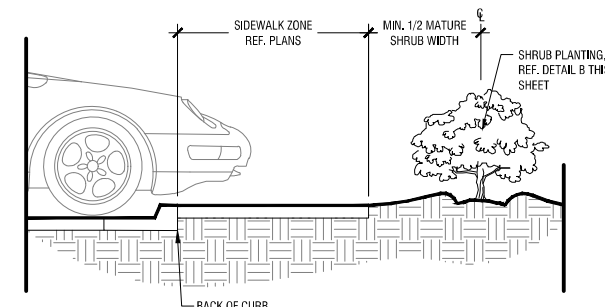

**D** Shrub Planting at Sidewalk

Scale: NTS

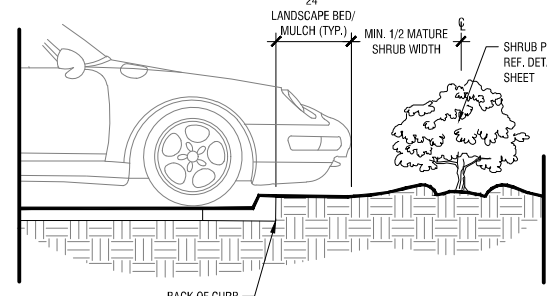

**F** Shrub Planting at Curb

Scale: NTS

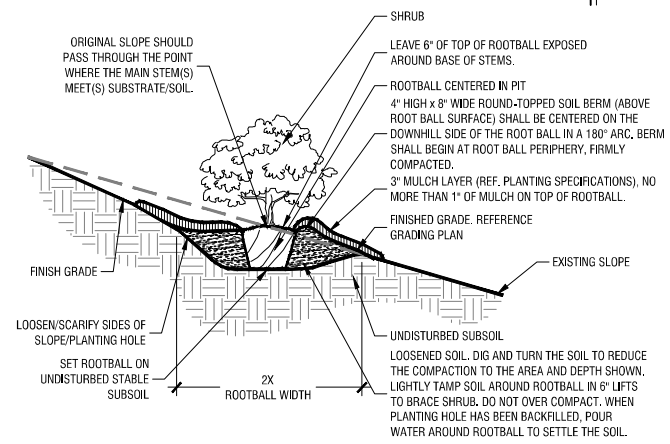

**C** Shrub Planting On 5-50% (20:1 TO 2:1) Slope

Scale: NTS

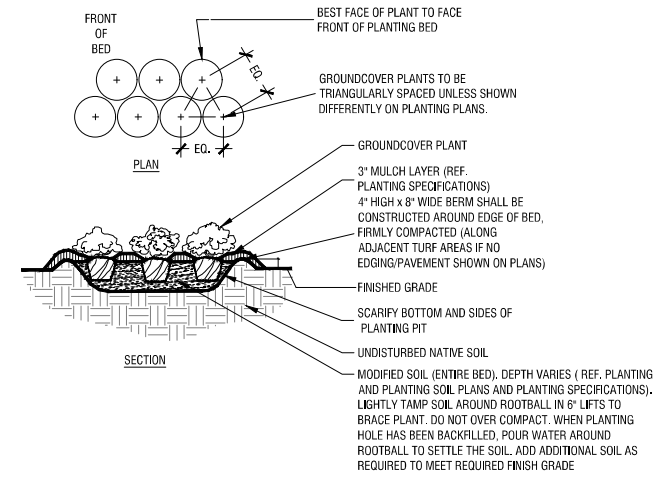

**A** Typical Groundcover Planting

Scale: NTS

**CAUTION!**  
 EXISTING UNDERGROUND UTILITIES IN THE AREA CONTRACTOR IS RESPONSIBLE FOR DETERMINING THE HORIZONTAL AND VERTICAL LOCATION OF ALL UTILITIES PRIOR TO CONSTRUCTION. CONTRACTOR SHALL BE RESPONSIBLE FOR ANY REPAIRS TO EXISTING UTILITIES DUE TO DAMAGE INCURRED DURING CONSTRUCTION. CONTRACTOR SHALL IMMEDIATELY NOTIFY THE ENGINEER OF ANY DISCREPANCIES ON THE PLANS.



04/05/2024

**Kimley Horn**

® Texas Registered Engineering Firm F-928

Texas Department of Transportation © 2024

**KELLER FM 1709 LANDSCAPE ENHANCEMENTS GREEN RIBBON PROGRAM PHASE II**  
KELLER, TEXAS

**LANDSCAPE DETAILS**

FED.RD.	PROJECT NO.	HIGHWAY NO.
FM 1709	SEE TITLE SHEET	FM 1709
STATE	DISTRICT	COUNTY
TEXAS	FTW	TARRANT
CONTROL	SECTION	JOB
1603	03	042

SHEET NO. 031



PLOTTED BY: PRESLEY, LAURA  
 PLOT DATE: 5/6/2024 2:31 PM  
 LOCATION: K:\FTW\_LALP\061097030\_KELLER GREEN RIBBON PH II\DWG\_04\_CD\SHEET\8 - IRRIGATION PLAN.DWG  
 LAST SAVED: 4/8/2024 10:52 AM

**IRRIGATION NOTES**

- IRRIGATION CONTRACTOR SHALL TEST EXISTING STATIC PRESSURE ON SITE PRIOR TO CONSTRUCTION. SHOULD EXISTING SITE PRESSURE BE BELOW 65 PSI, CONTRACTOR SHALL CONTACT THE IRRIGATION DESIGNER PRIOR TO COMMENCEMENT OF CONSTRUCTION.
- COORDINATE IRRIGATION INSTALLATION WITH PLANTING PLAN AND SITE CONDITIONS TO PROVIDE COMPLETE 100% COVERAGE WITH MINIMUM OVERSPRAY. THE IRRIGATION CONTRACTOR SHALL MAKE MINOR ADJUSTMENTS TO ENSURE PROPER COVERAGE AT NO ADDITIONAL COST TO THE OWNER.
- ALL CONSTRUCTION SHALL CONFORM TO CITY, COUNTY, STATE, AND FEDERAL REQUIREMENTS. IT SHALL BE THE RESPONSIBILITY OF THE IRRIGATION CONTRACTOR TO ENSURE THAT ALL IRRIGATION EQUIPMENT MEETS GOVERNMENT REGULATIONS. CONTRACTOR SHALL ALSO BE RESPONSIBLE FOR OBTAINING ANY NECESSARY PERMITS OR APPROVALS PRIOR TO COMMENCEMENT OF OPERATIONS ON-SITE. COPIES OF THE PERMITS SHALL BE SENT TO THE OWNER/GENERAL CONTRACTOR.
- LATERAL PIPE SHALL BE INSTALLED AT A MINIMUM DEPTH OF 12 INCHES. MAINLINE PIPE AND WIRES SHALL BE INSTALLED AT A MINIMUM DEPTH OF 18 INCHES.
- ELECTRICAL POWER SHALL BE PROVIDED WITHIN 5 FEET OF CONTROLLER LOCATION BY GENERAL CONTRACTOR. LICENSED IRRIGATION CONTRACTOR TO PROVIDE FINAL HARD WIRE TO CONTROLLER.
- 24 VOLT VALVE WIRE SHALL BE A MINIMUM OF 14 GAUGE, ILL. APPROVED FOR DIRECT BURIAL, SINGLE CONDUCTOR 'IRRIGATION WIRE'. CONTRACTOR TO CONFIRM WIRE SIZE PRIOR TO INSTALLATION. WIRE SPLICES SHALL BE ENCASED IN A WATERPROOF WIRE CONNECTOR UL APPROVED AND FILLED WITH SILICONE.
- IRRIGATION VALVES AND VALVE BOXES SHALL BE LOCATED IN LANDSCAPE BEDS OR GROUND COVER AREAS WHENEVER POSSIBLE. ALL REMOTE VALVE BOXES SHALL BE SET FLUSH WITH FINISHED GRADE AND CONTAIN ONE CUBIC FOOT OF CLEAN GRAVEL BENEATH VALVE. LABEL REMOTE BOXES WITH ONE-INCH ALPHA NUMERIC NOTATION CORRESPONDING TO THE APPLICABLE ALPHA CONTROLLER AND NUMERIC STATION. USE 10" ROUND VALVE BOXES FOR ELECTRIC VALVES AND QUICK COUPLING VALVES. USE 15" X 9.5" RECTANGULAR BOX FOR DRIP VALVES UNLESS NOTED OTHERWISE. DOUBLE CHECK ASSEMBLY SHALL BE BOXED ACCORDING TO LOCAL CODES.
- USE PVC SWING JOINT ASSEMBLIES TO CONNECT ALL SPRAY AND ROTOR HEADS.
- CONTRACTOR IS TO CONTACT APPROPRIATE AUTHORITIES AND LOCATE ALL UTILITIES PRIOR TO CONSTRUCTION. CONTRACTOR SHALL VERIFY ALL DIMENSIONS, ELEVATIONS, EQUIPMENT QUANTITIES, AND UTILITY LOCATIONS PRIOR TO BEGINNING WORK.
- SLEEVES SHALL BE INSTALLED BY GENERAL CONTRACTOR UNLESS OTHERWISE NOTED. SLEEVE MATERIAL SHALL BE PVC, SCH. 40, CONTRACTOR SHALL EXTEND SLEEVES 18 INCHES BEYOND EDGE OF ALL PAVEMENT. ELECTRICAL WIRES FOR IRRIGATION VALVES AND IRRIGATION LINES ARE TO BE PLACED IN SEPARATE SLEEVES. SEE SLEEVING DETAIL. ALL PRESSURE MAINLINES UNDER ASPHALT PAVEMENT SHALL BE PLACED WITHIN SLEEVES AS NOTED.
- DRIP LINE SHALL BE PLACED A MINIMUM OF 2" UNDER MULCH.
- LICENSED IRRIGATION CONTRACTOR SHALL ADJUST SPRAY NOZZLES FOR 'HEAD-TO-HEAD' COVERAGE AND ADJUST FOR MINIMUM OVERSPRAY ONTO PAVEMENT. NO OVERSPRAY IS PERMITTED ONTO STREETS OR SIDEWALKS.
- IRRIGATION CONTRACTOR SHALL SUPPLY AND CONSTRUCT IRRIGATION SYSTEM WITH ALL MATERIALS AND PER MANUFACTURER SPECIFICATIONS SHOWN ON THIS PLAN. IF CONTRACTOR PREFERENCES MATERIALS THAT DIFFER FROM THIS PLAN, THEY SHALL BE APPROVED BY THE IRRIGATION DESIGNER PRIOR TO CONSTRUCTION.
- VERIFY CONTROLLER AND RAIN SENSOR LOCATION AND MAINLINE POINT OF CONNECTION AT PROJECT SITE WITH OWNER.
- EXISTING TREES TO REMAIN ARE TO BE PROTECTED FROM DAMAGE, DO NOT TRENCH OR EXCAVATE WITHIN THE CRITICAL ROOT ZONE OF ANY TREE.
- IRRIGATION LATERAL LINES, MAIN LINES AND EQUIPMENT MAY BE SHOWN OUTSIDE PROPERTY LINES ON THIS PLAN, ALL IRRIGATION LINES AND EQUIPMENT ARE TO BE WITHIN AND INSTALLED WITHIN THE LIMITS OF THE PROPERTY LINE.
- SUPPLY LINE AND METER TO BE PROVIDED BY GENERAL CONTRACTOR. BACKFLOW PREVENTER TO BE PROVIDED BY IRRIGATION CONTRACTOR. IRRIGATION CONTRACTOR'S POINT OF CONNECTION TO BEGIN AFTER THE IRRIGATION WATER METER.
- IRRIGATION CONTRACTOR SHALL REVIEW WINTERIZATION PROCEDURES FOR IRRIGATION SYSTEM WITH OWNERS REPRESENTATIVE.
- ALL PLANT MATERIAL IN TREE HOLDING AREAS SHALL BE MANUALLY WATERED/IRRIGATED TO KEEP MOIST UNTIL PLANTED.
- MAINLINE, VALVES, AND WIRING ARE SHOWN ON DRAWINGS FOR CLARITY. SHOULD BE LOCATED IN ACCESSIBLE GREEN SPACE. CONTRACTOR TO COORDINATE WITH ALL DISCIPLINES TO AVOID CONFLICTS WITH UTILITIES/ STRUCTURES, ETC.
- INSTALLATION OF WORK SHALL BE COORDINATED WITH OTHER CONTRACTORS IN SUCH A MANNER AS TO ALLOW FOR A SPEEDY AND ORDERLY COMPLETION OF ALL WORK ON THE SITE.
- SET SPRAY HEADS 4" FROM BACK OF CURB OR 24" IF PAVEMENT HAS NO CURB.
- CONTRACTOR SHALL PROVIDE 'AS-BUILT' DRAWINGS OF THE FINAL INSTALLATION TO OWNER AT SUBSTANTIAL COMPLETION BEFORE RECEIVING FINAL PAYMENT. 'AS-BUILT' DRAWINGS TO BE COLOR CODED BY ZONE ON 8.5" X 11", LAMINATED, AND PLACED IN CONTROLLER.
- ALL DRIP ZONES SHALL BE INSTALLED WITH A SELF-FLUSHING DISC FILTER, OR APPROVED EQUAL.
- INSTALL ALL IRRIGATION COMPONENTS AS PER MANUFACTURERS REQUIREMENTS.
- IRRIGATION HEADS AND COMPONENTS SHALL BE LOCATED A MINIMUM OF 24" FROM ALL BUILDINGS TO AVOID ADVERSE PERFORMANCE OF FOUNDATIONS AND SLABS.
- NO LATERALS LESS THAN 3/4" DIAMETER.

**IRRIGATION LEGEND**

SYMBOL	MANUFACTURER/MODEL
	TORO 570S-FB-PC
SYMBOL	MANUFACTURER/MODEL
	HUNTER ICZ-101-25
	AREA TO RECEIVE DRIPLINE HUNTER HDL-06-18-PC
SYMBOL	MANUFACTURER/MODEL
	HUNTER ICV-G
	ISOLATION VALVE
	HUNTER ICV-G 1"
	FEBC0 825Y 1"
	RAIN BRD ESPLXME2-LXMM-LXMMPED
	RAIN BRD RSD-BEX
	WATER METER 1"
	IRRIGATION LATERAL LINE: PVC CLASS 200 SDR 12
	IRRIGATION MAINLINE: PVC CLASS 200 SDR 21
	PIPE SLEEVE: PVC SCHEDULE 40
REF. SHEET 035 FOR FULL IRRIGATION SCHEDULE.	
	Valve Number
	Valve Flow
	Valve Size

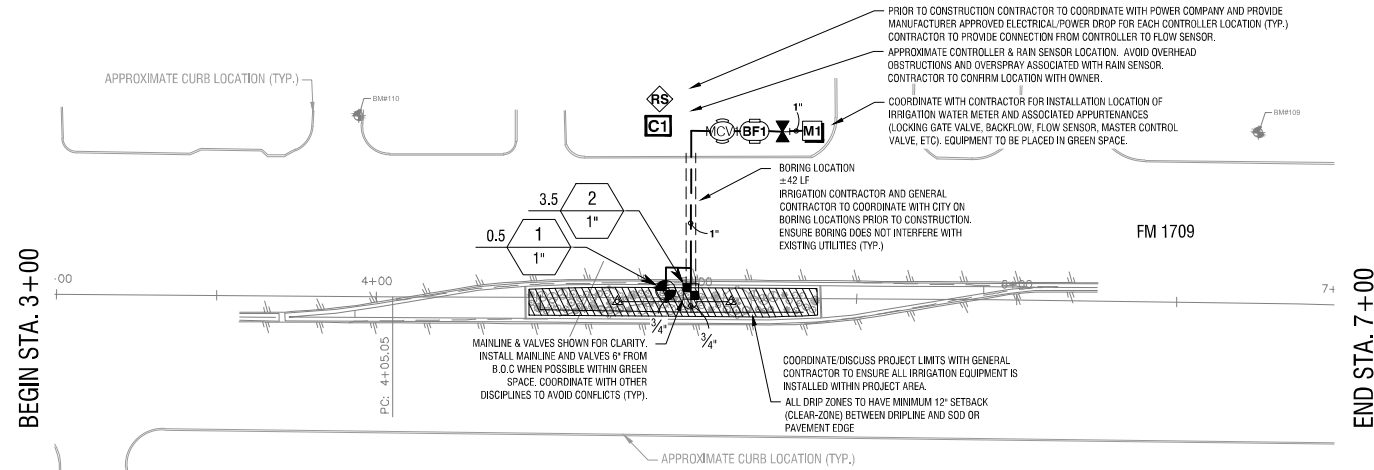

**A** BEGIN STA. 3+00 TO END STA. 7+00  
PLAN

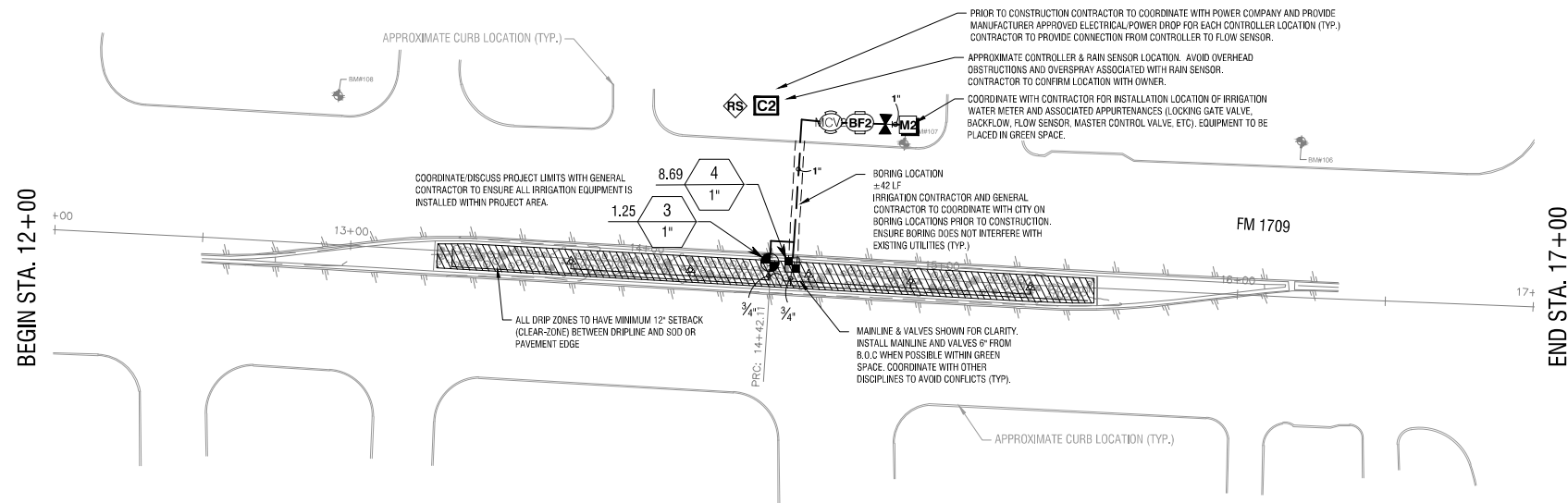

**B** BEGIN STA. 12+00 TO END STA. 17+00  
PLAN

THIS IRRIGATION PLAN IS DESIGNED TO THE FOLLOWING STATS: 65 PSI AND 75 GPM. IF WATER PRESSURE DOES NOT MEET DESIGN SPECIFICATIONS A BOOSTER PUMP WILL BE REQUIRED AT COST OF CONTRACTOR. CONTACT LANDSCAPE ARCHITECT PRIOR TO INSTALLATION IF SYSTEM HAS +/- 5 PSI THAN DESIGN PRESSURE.

ABOVE QUANTITIES PROVIDED FOR CONVENIENCE ONLY. CONTRACTOR TO CONFIRM ALL QUANTITIES PRIOR TO BIDDING.

REFERENCE MAXIMUM LATERAL DRIPLINE CHART TO DETERMINE MINIMUM NUMBER OF POINTS OF CONNECTION PER DRIP LINE ZONE.

WHERE LAYOUT FLEXIBILITY EXISTS CENTER FEED LAYOUTS MUST BE USED. THIS ALLOWS FOR EVEN FLOW OF WATER THROUGH THE ZONE.

HUNTER ECO-INDICATOR TO BE PLACED IN ALL DRIP AREAS AT THE FURTHEST POINT OF EACH DRIP RUN.

ZONES LOWER THAN THE CAPACITY OF THE FLOW SENSOR ARE TO BE WIRED IN THE CONTROLLER WITH ANOTHER ZONE SO THAT THE FLOW SENSOR READS BOTH ZONES AS ONE ZONE IN ORDER TO MEET THE FLOW SENSOR'S LOWEST GPM REQUIREMENT. DRIP ZONES REQUIRED TO REMAIN PIPED AS SEPARATE ZONES.

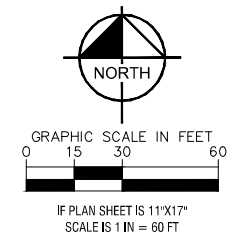
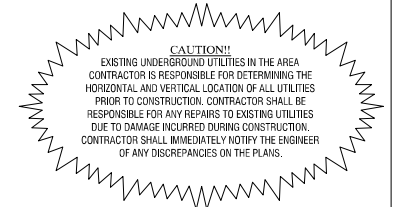

04/05/2024

**Kimley Horn**  
 Texas Registered Engineering Firm F-928  
 Texas Department of Transportation  
 © 2024

**KELLER FM 1709 LANDSCAPE ENHANCEMENTS GREEN RIBBON PROGRAM PHASE II**  
 KELLER, TEXAS

**IRRIGATION PLAN**  
 STA. 3+00 TO STA. 7+00  
 STA. 12+00 TO STA. 17+00

FED.RD.	PROJECT NO.	HIGHWAY NO.
FM 1709	SEE TITLE SHEET	FM 1709
STATE	DISTRICT	COUNTY
TEXAS	FTW	TARRANT
CONTROL	SECTION	JOB
1603	03	042

SHEET NO. 033

PLOTTED BY: PRESLEY, LAURA  
 PLOT DATE: 5/6/2024 2:31 PM  
 LOCATION: K:\FTW\_LALP\061097030\_KELLER GREEN RIBBON PH II\DWG\04 CD\SHEET\8 - IRRIGATION PLAN.DWG  
 LAST SAVED: 4/8/2024 10:52 AM

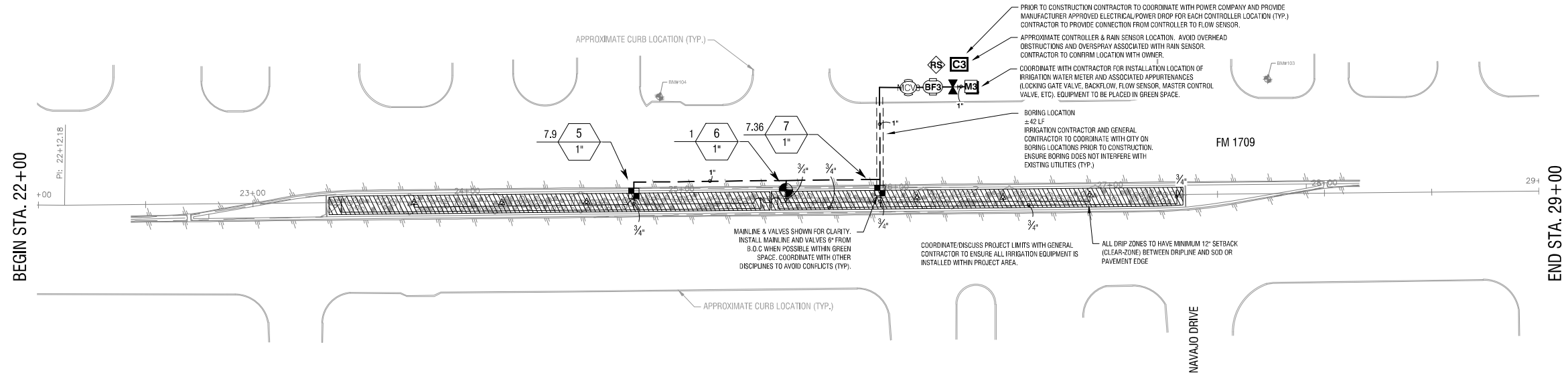

**IRRIGATION LEGEND**

SYMBOL	MANUFACTURER/MODEL
	TORO 570S-FB-PC
	HUNTER ICZ-101-25
	HUNTER HDL-06-18-PC
SYMBOL	MANUFACTURER/MODEL
	HUNTER ICV-G
	ISOLATION VALVE
	HUNTER ICV-G 1"
	FEBCO 825Y 1"
	RAIN BIRD ESPLXME2-LXMM-LXMMPED
	RAIN BIRD RSD-BEX
	WATER METER 1"
	IRRIGATION LATERAL LINE: PVC CLASS 200 SDR 21
	IRRIGATION MAINLINE: PVC CLASS 200 SDR 21
	PIPE SLEEVE: PVC SCHEDULE 40

REF. SHEET 035 FOR FULL IRRIGATION SCHEDULE.

Valve Number  
 Valve Flow  
 Valve Size

**C** ALTERNATE BID: BEGIN STA. 22+00 TO END STA. 29+00  
PLAN

**CAUTION!**  
 EXISTING UNDERGROUND UTILITIES IN THE AREA CONTRACTOR IS RESPONSIBLE FOR DETERMINING THE HORIZONTAL AND VERTICAL LOCATION OF ALL UTILITIES PRIOR TO CONSTRUCTION. CONTRACTOR SHALL BE RESPONSIBLE FOR ANY REPAIRS TO EXISTING UTILITIES DUE TO DAMAGE INCURRED DURING CONSTRUCTION. CONTRACTOR SHALL IMMEDIATELY NOTIFY THE ENGINEER OF ANY DISCREPANCIES ON THE PLANS.

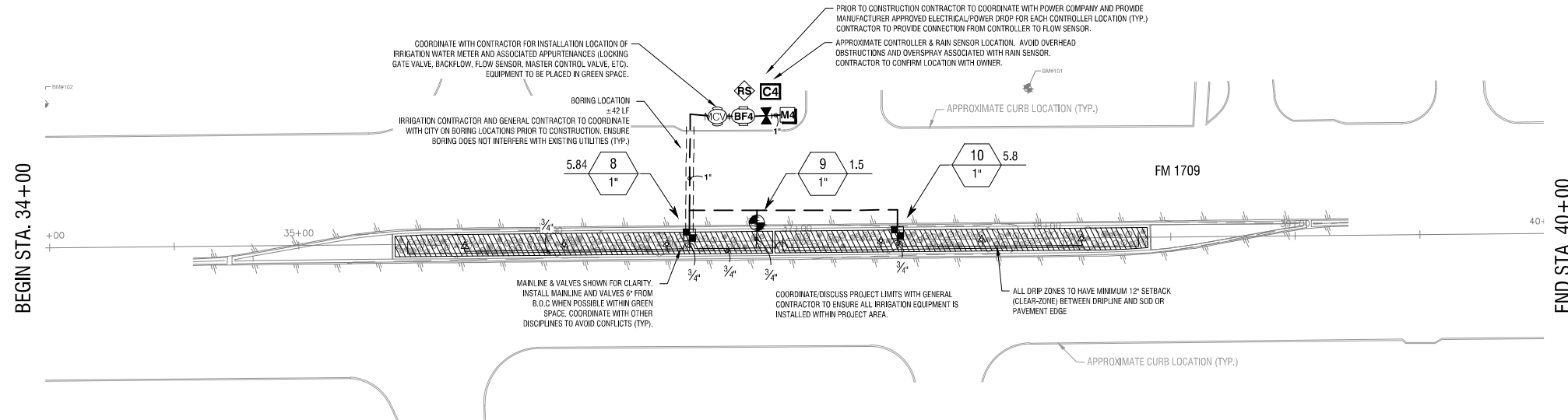

THIS IRRIGATION PLAN IS DESIGNED TO THE FOLLOWING STATS: 65 PSI AND 75 GPM. IF WATER PRESSURE DOES NOT MEET DESIGN SPECIFICATIONS A BOOSTER PUMP WILL BE REQUIRED AT COST OF CONTRACTOR. CONTACT LANDSCAPE ARCHITECT PRIOR TO INSTALLATION IF SYSTEM HAS +/- 5 PSI THAN DESIGN PRESSURE.  
 ABOVE QUANTITIES PROVIDED FOR CONVENIENCE ONLY. CONTRACTOR TO CONFIRM ALL QUANTITIES PRIOR TO BIDDING.  
 REFERENCE MAXIMUM LATERAL DRIFLINE CHART TO DETERMINE MINIMUM NUMBER OF POINTS OF CONNECTION PER DRIFLINE ZONE.  
 WHERE LAYOUT FLEXIBILITY EXISTS CENTER FEED LAYOUTS MUST BE USED. THIS ALLOWS FOR EVEN FLOW OF WATER THROUGH THE ZONE.  
 HUNTER ECO-INDICATOR TO BE PLACED IN ALL DRIP AREAS AT THE FURTHEST POINT OF EACH DRIP RUN.  
 ZONES LOWER THAN THE CAPACITY OF THE FLOW SENSOR ARE TO BE WIRED IN THE CONTROLLER WITH ANOTHER ZONE SO THAT THE FLOW SENSOR READS BOTH ZONES AS ONE ZONE IN ORDER TO MEET THE FLOW SENSOR'S LOWEST GPM REQUIREMENT. DRIP ZONES REQUIRED TO REMAIN PIPED AS SEPARATE ZONES.

**D** ALTERNATE BID: BEGIN STA. 34+00 TO END STA. 40+00  
PLAN

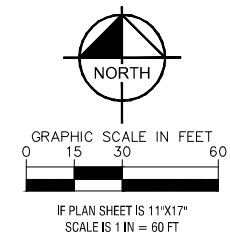

04/05/2024

**Kimley»Horn**

® Texas Registered Engineering Firm F-928

Texas Department of Transportation  
© 2024

**KELLER FM 1709 LANDSCAPE ENHANCEMENTS GREEN RIBBON PROGRAM PHASE II**  
KELLER, TEXAS

**IRRIGATION PLAN**  
STA. 22+00 TO STA. 29+00  
STA. 34+00 TO STA. 40+00

FED.RD.	PROJECT NO.	HIGHWAY NO.
FM 1709	SEE TITLE SHEET	FM 1709
STATE	DISTRICT	COUNTY
TEXAS	FTW	TARRANT
CONTROL	SECTION	JOB
1603	03	042

SHEET NO. 034

IRRIGATION SCHEDULE METER 1

SYMBOL	MANUFACTURER/MODEL/DESCRIPTION	QTY
	TORO 570S-FB-PC PRESSURE-COMPENSATING FLOOD BUBBLER NOZZLE ON 570S FIXED RISER, 0.25 GPM, 0.5 GPM, 1.0 GPM, AND 2.0 GPM.	2
	HUNTER ICZ-101-25 DRIP CONTROL ZONE KIT. 1IN. ICV GLOBE VALVE WITH 1IN. HY100 FILTER SYSTEM. PRESSURE REGULATION: 25PSI. FLOW RANGE: 2 GPM TO 20 GPM. 150 MESH STAINLESS STEEL SCREEN.	1
	AREA TO RECEIVE DRIPLINE HUNTER HDL-06-18-PC HDL-06-18-PC: HUNTER DRIPLINE WITH 0.6 GPH FLOW. LIGHT BROWN TUBING WITH GRAY STRIPING. EMITTERS AT 18" O.C. DRIPLINE LATERALS SPACED AT 18" APART, WITH EMITTERS OFFSET FOR TRIANGULAR PATTERN. INSTALL WITH HUNTER PLD BARBED OR PLD-LOC FITTINGS.	524.6 L.F.
	HUNTER ICV-G 1IN., 1-1/2IN., 2IN., AND 3IN. PLASTIC ELECTRIC REMOTE CONTROL VALVES, GLOBE CONFIGURATION, WITH NPT THREADED INLET/OUTLET, FOR COMMERCIAL/MUNICIPAL USE.	1
	ISOLATION VALVE	1
	HUNTER ICV-G 1" 1IN., 1-1/2IN., 2IN., AND 3IN. PLASTIC ELECTRIC MASTER VALVE, GLOBE CONFIGURATION, WITH NPT THREADED INLET/OUTLET, FOR COMMERCIAL/MUNICIPAL USE.	1
	FEBCO 825Y 1" REDUCED PRESSURE BACKFLOW PREVENTER	1
	RAIN BIRD ESP/ME2-LXMM-LXMMPED 12 STATION, TRADITIONALLY-WIRED, COMMERCIAL CONTROLLER, INDOOR/OUTDOOR, PLASTIC WALL-MOUNT ENCLOSURE. INSTALL IN LXMM-LXMMPED POWDER COATED, METAL WALL-MOUNTED CABINET. W/ PEDESTAL.	1
	RAIN BIRD RSD-BEX RAIN SENSOR, WITH METAL LATCHING BRACKET, EXTENSION WIRE.	1
	WATER METER 1"	1
	IRRIGATION LATERAL LINE: PVC CLASS 200 SDR 21	132.3 L.F.
	IRRIGATION MAINLINE: PVC CLASS 200 SDR 21	102.9 L.F.
	PIPE SLEEVE: PVC SCHEDULE 40	41.6 L.F.

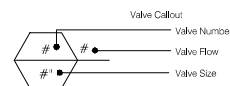

IRRIGATION SCHEDULE METER 2

SYMBOL	MANUFACTURER/MODEL/DESCRIPTION	QTY
	TORO 570S-FB-PC PRESSURE-COMPENSATING FLOOD BUBBLER NOZZLE ON 570S FIXED RISER, 0.25 GPM, 0.5 GPM, 1.0 GPM, AND 2.0 GPM.	5
	HUNTER ICZ-101-25 DRIP CONTROL ZONE KIT. 1IN. ICV GLOBE VALVE WITH 1IN. HY100 FILTER SYSTEM. PRESSURE REGULATION: 25PSI. FLOW RANGE: 2 GPM TO 20 GPM. 150 MESH STAINLESS STEEL SCREEN.	1
	AREA TO RECEIVE DRIPLINE HUNTER HDL-06-18-PC HDL-06-18-PC: HUNTER DRIPLINE WITH 0.6 GPH FLOW. LIGHT BROWN TUBING WITH GRAY STRIPING. EMITTERS AT 18" O.C. DRIPLINE LATERALS SPACED AT 18" APART, WITH EMITTERS OFFSET FOR TRIANGULAR PATTERN. INSTALL WITH HUNTER PLD BARBED OR PLD-LOC FITTINGS.	1,303 L.F.
	HUNTER ICV-G 1IN., 1-1/2IN., 2IN., AND 3IN. PLASTIC ELECTRIC REMOTE CONTROL VALVES, GLOBE CONFIGURATION, WITH NPT THREADED INLET/OUTLET, FOR COMMERCIAL/MUNICIPAL USE.	1
	ISOLATION VALVE	1
	HUNTER ICV-G 1" 1IN., 1-1/2IN., 2IN., AND 3IN. PLASTIC ELECTRIC MASTER VALVE, GLOBE CONFIGURATION, WITH NPT THREADED INLET/OUTLET, FOR COMMERCIAL/MUNICIPAL USE.	1
	FEBCO 825Y 1" REDUCED PRESSURE BACKFLOW PREVENTER	1
	RAIN BIRD ESP/ME2-LXMM-LXMMPED 12 STATION, TRADITIONALLY-WIRED, COMMERCIAL CONTROLLER, INDOOR/OUTDOOR, PLASTIC WALL-MOUNT ENCLOSURE. INSTALL IN LXMM-LXMMPED POWDER COATED, METAL WALL-MOUNTED CABINET. W/ PEDESTAL.	1
	RAIN BIRD RSD-BEX RAIN SENSOR, WITH METAL LATCHING BRACKET, EXTENSION WIRE.	1
	WATER METER 1"	1
	IRRIGATION LATERAL LINE: PVC CLASS 200 SDR 21	401.2 L.F.
	IRRIGATION MAINLINE: PVC CLASS 200 SDR 21	100.3 L.F.
	PIPE SLEEVE: PVC SCHEDULE 40	42.4 L.F.

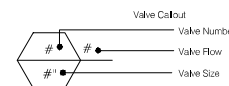

ALTERNATE BID: IRRIGATION SCHEDULE METER 3

SYMBOL	MANUFACTURER/MODEL/DESCRIPTION	QTY
	TORO 570S-FB-PC PRESSURE-COMPENSATING FLOOD BUBBLER NOZZLE ON 570S FIXED RISER, 0.25 GPM, 0.5 GPM, 1.0 GPM, AND 2.0 GPM.	6
	HUNTER ICZ-101-25 DRIP CONTROL ZONE KIT. 1IN. ICV GLOBE VALVE WITH 1IN. HY100 FILTER SYSTEM. PRESSURE REGULATION: 25PSI. FLOW RANGE: 2 GPM TO 20 GPM. 150 MESH STAINLESS STEEL SCREEN.	2
	AREA TO RECEIVE DRIPLINE HUNTER HDL-06-18-PC HDL-06-18-PC: HUNTER DRIPLINE WITH 0.6 GPH FLOW. LIGHT BROWN TUBING WITH GRAY STRIPING. EMITTERS AT 18" O.C. DRIPLINE LATERALS SPACED AT 18" APART, WITH EMITTERS OFFSET FOR TRIANGULAR PATTERN. INSTALL WITH HUNTER PLD BARBED OR PLD-LOC FITTINGS.	2,289 L.F.
	HUNTER ICV-G 1IN., 1-1/2IN., 2IN., AND 3IN. PLASTIC ELECTRIC REMOTE CONTROL VALVES, GLOBE CONFIGURATION, WITH NPT THREADED INLET/OUTLET, FOR COMMERCIAL/MUNICIPAL USE.	1
	ISOLATION VALVE	1
	HUNTER ICV-G 1" 1IN., 1-1/2IN., 2IN., AND 3IN. PLASTIC ELECTRIC MASTER VALVE, GLOBE CONFIGURATION, WITH NPT THREADED INLET/OUTLET, FOR COMMERCIAL/MUNICIPAL USE.	1
	FEBCO 825Y 1" REDUCED PRESSURE BACKFLOW PREVENTER	1
	RAIN BIRD ESP/ME2-LXMM-LXMMPED 12 STATION, TRADITIONALLY-WIRED, COMMERCIAL CONTROLLER, INDOOR/OUTDOOR, PLASTIC WALL-MOUNT ENCLOSURE. INSTALL IN LXMM-LXMMPED POWDER COATED, METAL WALL-MOUNTED CABINET. W/ PEDESTAL.	1
	RAIN BIRD RSD-BEX RAIN SENSOR, WITH METAL LATCHING BRACKET, EXTENSION WIRE.	1
	WATER METER 1"	1
	IRRIGATION LATERAL LINE: PVC CLASS 200 SDR 21	751.2 L.F.
	IRRIGATION MAINLINE: PVC CLASS 200 SDR 21	215.3 L.F.
	PIPE SLEEVE: PVC SCHEDULE 40	42.2 L.F.

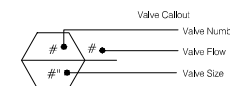

ALTERNATE BID: IRRIGATION SCHEDULE METER 4

SYMBOL	MANUFACTURER/MODEL/DESCRIPTION	QTY
	TORO 570S-FB-PC PRESSURE-COMPENSATING FLOOD BUBBLER NOZZLE ON 570S FIXED RISER, 0.25 GPM, 0.5 GPM, 1.0 GPM, AND 2.0 GPM.	6
	HUNTER ICZ-101-25 DRIP CONTROL ZONE KIT. 1IN. ICV GLOBE VALVE WITH 1IN. HY100 FILTER SYSTEM. PRESSURE REGULATION: 25PSI. FLOW RANGE: 2 GPM TO 20 GPM. 150 MESH STAINLESS STEEL SCREEN.	2
	AREA TO RECEIVE DRIPLINE HUNTER HDL-06-18-PC HDL-06-18-PC: HUNTER DRIPLINE WITH 0.6 GPH FLOW. LIGHT BROWN TUBING WITH GRAY STRIPING. EMITTERS AT 18" O.C. DRIPLINE LATERALS SPACED AT 18" APART, WITH EMITTERS OFFSET FOR TRIANGULAR PATTERN. INSTALL WITH HUNTER PLD BARBED OR PLD-LOC FITTINGS.	1,746 L.F.
	HUNTER ICV-G 1IN., 1-1/2IN., 2IN., AND 3IN. PLASTIC ELECTRIC REMOTE CONTROL VALVES, GLOBE CONFIGURATION, WITH NPT THREADED INLET/OUTLET, FOR COMMERCIAL/MUNICIPAL USE.	1
	ISOLATION VALVE	1
	HUNTER ICV-G 1" 1IN., 1-1/2IN., 2IN., AND 3IN. PLASTIC ELECTRIC MASTER VALVE, GLOBE CONFIGURATION, WITH NPT THREADED INLET/OUTLET, FOR COMMERCIAL/MUNICIPAL USE.	1
	FEBCO 825Y 1" REDUCED PRESSURE BACKFLOW PREVENTER	1
	RAIN BIRD ESP/ME2-LXMM-LXMMPED 12 STATION, TRADITIONALLY-WIRED, COMMERCIAL CONTROLLER, INDOOR/OUTDOOR, PLASTIC WALL-MOUNT ENCLOSURE. INSTALL IN LXMM-LXMMPED POWDER COATED, METAL WALL-MOUNTED CABINET. W/ PEDESTAL.	1
	RAIN BIRD RSD-BEX RAIN SENSOR, WITH METAL LATCHING BRACKET, EXTENSION WIRE.	1
	WATER METER 1"	1
	IRRIGATION LATERAL LINE: PVC CLASS 200 SDR 21	588.0 L.F.
	IRRIGATION MAINLINE: PVC CLASS 200 SDR 21	185.2 L.F.
	PIPE SLEEVE: PVC SCHEDULE 40	42.0 L.F.

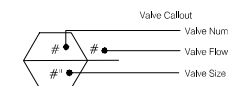

**CAUTION!!**  
EXISTING UNDERGROUND UTILITIES IN THE AREA CONTRACTOR IS RESPONSIBLE FOR DETERMINING THE HORIZONTAL AND VERTICAL LOCATION OF ALL UTILITIES PRIOR TO CONSTRUCTION. CONTRACTOR SHALL BE RESPONSIBLE FOR ANY REPAIRS TO EXISTING UTILITIES DUE TO DAMAGE INCURRED DURING CONSTRUCTION. CONTRACTOR SHALL IMMEDIATELY NOTIFY THE ENGINEER OF ANY DISCREPANCIES ON THE PLANS.

THIS IRRIGATION PLAN IS DESIGNED TO THE FOLLOWING STATS: 65 PSI AND 75 GPM. IF WATER PRESSURE DOES NOT MEET DESIGN SPECIFICATIONS A BOOSTER PUMP WILL BE REQUIRED AT COST OF CONTRACTOR. CONTACT LANDSCAPE ARCHITECT PRIOR TO INSTALLATION IF SYSTEM HAS +/- 5 PSI THAN DESIGN PRESSURE.

ABOVE QUANTITIES PROVIDED FOR CONVENIENCE ONLY. CONTRACTOR TO CONFIRM ALL QUANTITIES PRIOR TO BIDDING.

REFERENCE MAXIMUM LATERAL DRIPLINE CHART TO DETERMINE MINIMUM NUMBER OF POINTS OF CONNECTION PER DRIPLINE ZONE.

WHERE LAYOUT FLEXIBILITY EXISTS CENTER FEED LAYOUTS MUST BE USED. THIS ALLOWS FOR EVEN FLOW OF WATER THROUGH THE ZONE.

HUNTER ECO-INDICATOR TO BE PLACED IN ALL DRIP AREAS AT THE FURTHEST POINT OF EACH DRIP RUN.

ZONES LOWER THAN THE CAPACITY OF THE FLOW SENSOR ARE TO BE WIRED IN THE CONTROLLER WITH ANOTHER ZONE SO THAT THE FLOW SENSOR READS BOTH ZONES AS ONE ZONE IN ORDER TO MEET THE FLOW SENSOR'S LOWEST GPM REQUIREMENT. DRIP ZONES REQUIRED TO REMAIN PIPED AS SEPARATE ZONES.



04/05/2024

**Kimley Horn**  
Texas Registered Engineering Firm F-928

Texas Department of Transportation  
© 2024

**KELLER FM 1709 LANDSCAPE ENHANCEMENTS GREEN RIBBON PROGRAM PHASE II**  
KELLER, TEXAS

**IRRIGATION SCHEDULES**

FED.RD.	PROJECT NO.	HIGHWAY NO.
FM 1709	SEE TITLE SHEET	FM 1709
STATE	DISTRICT	COUNTY
TEXAS	FTW	TARRANT
CONTROL	SECTION	JOB
1603	03	042

SHEET NO. 035

PLOTTED BY: PRESLEY, LAURA  
5/6/2024 2:31 PM  
LOCATION: K:\FTW\_LALP\061097030\_KELLER GREEN RIBBON PH II\DWG\_04\_CD\SHEET\8 - IRRIGATION PLAN.DWG  
LAST SAVED: 4/8/2024 10:52 AM

PLOTTED BY: PRESLEY, LAURA  
 PLOT DATE: 5/6/2024 2:33 PM  
 LOCATION: K:\FTW\_LALP\061097030\_KELLER GREEN RIBBON PH II\DWG\04\_CD\SHEET\9 - IRRIGATION DETAILS.DWG  
 LAST SAVED: 4/8/2024 10:45 AM

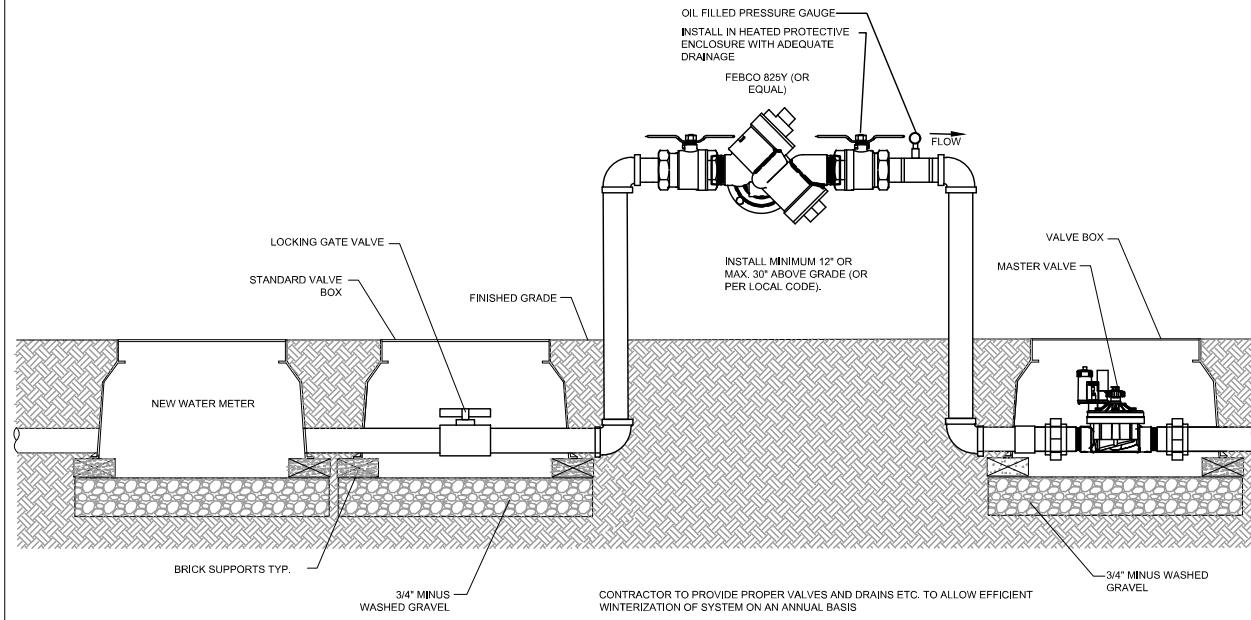

**METER B - RPZ Assembly Backflow Preventer**

Scale: N.T.S.

**K**

**Air/Vacuum Relief (Plumbed to Poly)**

Scale: N.T.S.

**H**

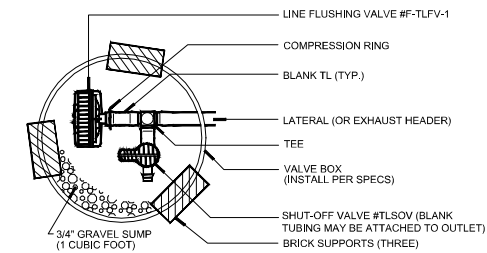

**Line Flushing Valve (W/ Shut-off Valve)**

Scale: N.T.S.

**F**

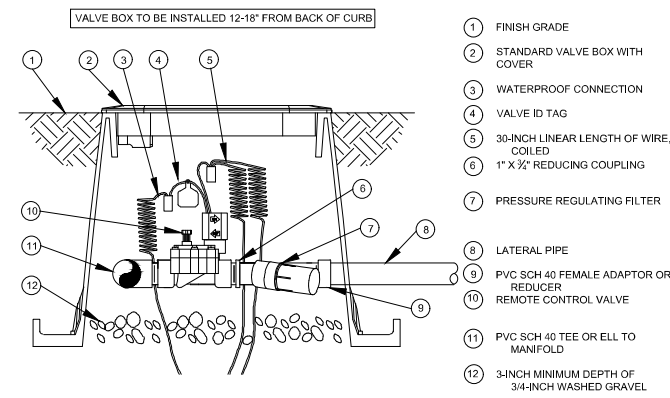

**Drip Control Zone Kit**

Scale: N.T.S.

**E**

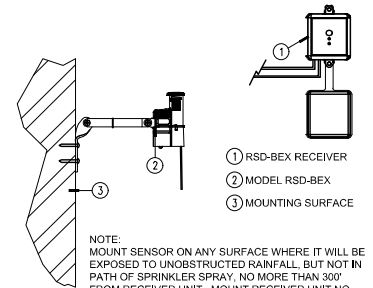

**Wireless Rain/Freeze Sensor**

Scale: N.T.S.

**B**

PVC PIPE SIZE	SOLVENT WELD SCH. 40 FITTINGS	BELL AND GASKET FITTINGS	SOCKETED PIPE
1/2"	2"	-	2"
3/4"	2"	-	2"
1"	2 1/2"	-	2 1/2"
1 1/4"	3"	-	3"
1 1/2"	3"	3"	3"
2"	4"	4"	4"
2 1/2"	6"	6"	6"
3"	6"	6"	6"
4"	8"	8"	8"

**Sleeve Schedule**

Scale: N.T.S.

**A**

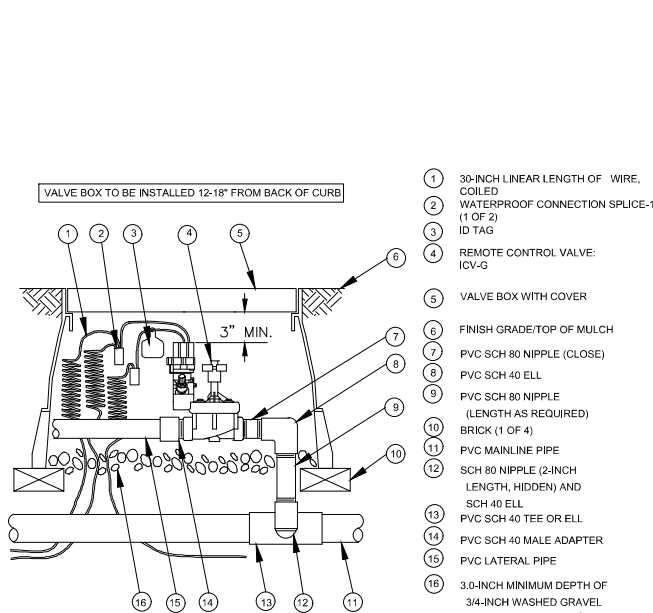

**Electric Remote Control Valve**

Scale: N.T.S.

**M**

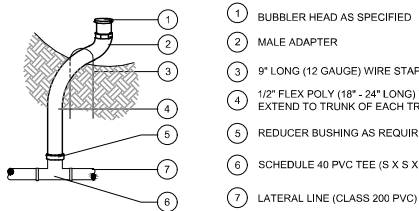

**Bubbler Assembly**

Scale: N.T.S.

**L**

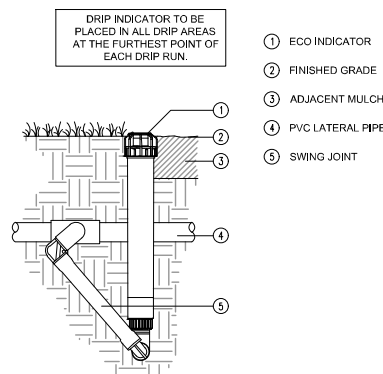

**ECO INDICATOR - SWING JOINT**

Scale: N.T.S.

**J**

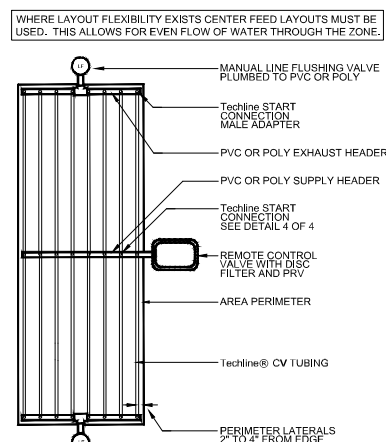

ALL BARBED FITTINGS TO UTILIZE EITHER STAINLESS STEEL HOSE CLAMPS, STEEL CRIMP, OR COMPRESSION RING.

INLET PRESSURE (PSI)	12"			18"			24"			
	0.26	0.4	0.6	0.9	0.26	0.4	0.6	0.9	0.6	0.9
20	331	242	190	144	468	344	270	204	342	260
25	413	302	238	180	584	429	338	257	430	326
35	518	380	299	227	737	540	426	323	542	412
45	594	436	343	260	845	620	489	371	622	472
55	655	480	378	287	932	684	539	410	686	522
60	681	580	393	298	969	713	561	426	716	544

**Techline CV Center Feed Layout**

Scale: N.T.S.

**G**

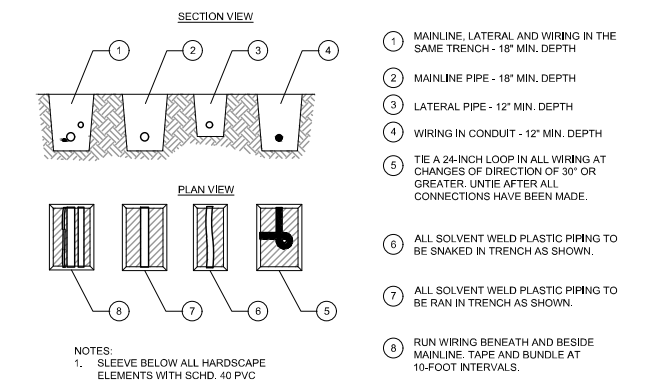

**Pipe and Wire Trenching**

Scale: N.T.S.

**D**

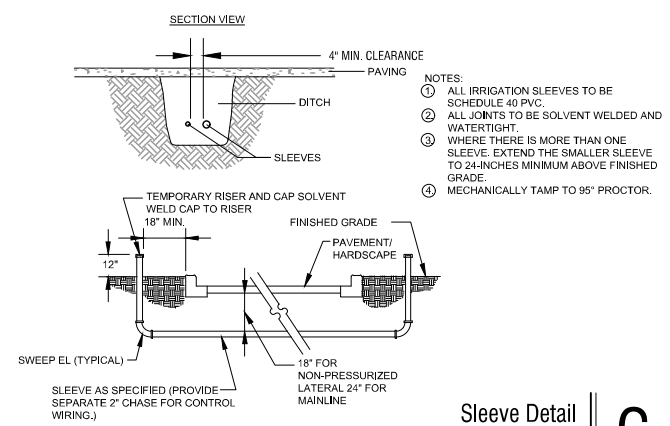

**Sleeve Detail**

Scale: N.T.S.

**C**

**CAUTION!**  
 EXISTING UNDERGROUND UTILITIES IN THE AREA CONTRACTOR IS RESPONSIBLE FOR DETERMINING THE HORIZONTAL AND VERTICAL LOCATION OF ALL UTILITIES PRIOR TO CONSTRUCTION. CONTRACTOR SHALL BE RESPONSIBLE FOR ANY REPAIRS TO EXISTING UTILITIES DUE TO DAMAGE INCURRED DURING CONSTRUCTION. CONTRACTOR SHALL IMMEDIATELY NOTIFY THE ENGINEER OF ANY DISCREPANCIES ON THE PLANS.



04/05/2024

**Kimley Horn**  
 Texas Registered Engineering Firm F-928  
 Texas Department of Transportation  
 © 2024

**KELLER FM 1709 LANDSCAPE ENHANCEMENTS GREEN RIBBON PROGRAM PHASE II**  
 KELLER, TEXAS

**IRRIGATION DETAILS**

FED. RD.	PROJECT NO.	HIGHWAY NO.	
FM 1709	SEE TITLE SHEET	FM 1709	
STATE	DISTRICT	COUNTY	SHEET NO.
TEXAS	FTW	TARRANT	036
CONTROL	SECTION	JOB	
1603	03	042	

GENERAL IRRIGATION NOTES:

1. CONTRACTOR SHALL BE RESPONSIBLE FOR REFERENCING ITEM 170 OF THE TEXAS STANDARD SPECIFICATIONS FOR CONSTRUCTION OF HIGHWAYS, STREETS AND BRIDGES 2004 FOR SPECIFICATIONS, DIMENSIONS, VOLUMES AND MEASUREMENTS THAT HAVE BEEN MODIFIED OR NOT SHOWN.
2. THE CONTRACTOR SHALL BE RESPONSIBLE FOR OBTAINING ALL PERMITS, LICENSES, TESTS, AND/OR APPROVALS, PAYING ANY FEES (INCLUDING IMPACT FEES) AND DEPOSITS AND INSTALLING OR ARRANGING FOR ALL WATER METERS AND TAPS FOR INSTALLATION AND OPERATION AS APPLICABLE. DEPOSITS WILL NOT BE REFUNDED. WATER METERS SHALL BE PLACED IN NAME OF THE CONTRACTOR, AS PROVIDED BY ENGINEER. THE CONTRACTOR WILL PAY FOR MONTHLY WATER CHARGES DURING THE PROJECT. WATER METERS SHALL REMAIN OPERATIONAL AND TURNED ON THROUGH ALL PHASES OF THE CONTRACT TO ENSURE PLANTS RECEIVE REQUIRED WATERING. TRANSFER METER TO CITY OF HURST AT THE END OF PROJECT.
3. THE CONTRACTOR IS RESPONSIBLE FOR EXTENDING A 1" CONDUIT WITH 2-#12 INSULATED CONDUCTORS AND 1-#8 BARE CONDUCTOR FROM EXISTING ELECTRICAL SERVICE TO THE CONTROLLER LOCATION.
4. BACKFLOW PREVENTERS SHALL BE PLACED IN THE NAME OF THE CITY OF HURST PROVIDED BY ENGINEER. THE CONTRACTOR SHALL BE RESPONSIBLE FOR ALL CHARGES, FEES, TESTS, AND COORDINATION FOR ANY BACKFLOW PREVENTER TESTING, AT INSTALLATION OR ANNUAL INSPECTION, REQUIRED BY LOCAL ENTITY THROUGH ALL PHASES OF THE CONTRACT.
5. THE DRAWINGS ARE DIAGRAMMATIC OF THE WORK TO BE PERFORMED. CHANGES MAY BE REQUIRED DUE TO VARYING CONDITIONS OR AS DIRECTED BY THE ENGINEER.
6. CONTRACTOR SHALL VERIFY LOCATION OF ANY UNDERGROUND UTILITIES WITH APPROPRIATE AGENCIES. UNDERGROUND UTILITIES (IF SHOWN) ON THE PLANS ARE APPROXIMATE.
7. SEE IRRIGATION DETAILS AND MATERIALS CHART FOR MATERIALS SPECIFICATIONS, SIZES, AND REQUIREMENTS.
8. CONTRACTOR SHALL COORDINATE IRRIGATION INSTALLATION WITH LANDSCAPE PLAN AND SITE CONDITIONS TO PROVIDE COMPLETE COVERAGE WITH MINIMUM OVERSPRAY. THE IRRIGATION CONTRACTOR SHALL MAKE MINOR ADJUSTMENTS TO ENSURE PROPER COVERAGE AT NO ADDITIONAL COST TO THE OWNER.
9. CONTRACTOR SHALL REQUEST CABLE LOCATES FROM TXDOT FTW DISTRICT SIGN SHOP (817-370-3661) PRIOR TO BEGINNING WORK OUTSIDE OF THE MEDIANS.

CONSTRUCTION METHODS:

9. THE CONTRACTOR SHALL INVESTIGATE THE SITE CONDITIONS AFFECTING THE WORK AND SHALL FURNISH OFFSETS, FITTINGS, AND SLEEVES AS MAY BE REQUIRED TO MEET SITE CONDITIONS.
10. ALL IRRIGATION VALVES, MAINLINES, LATERALS, BORINGS, ETC. SHALL BE LOCATED FOR APPROVAL BY THE ENGINEER PRIOR TO INSTALLATION.
11. DEVIATIONS IN THE PIPING AS SHOWN ON THE PLANS SHALL BE PERMITTED WITH APPROVAL, IN WRITING, FROM THE ENGINEERING.
12. CARE SHALL BE EXERCISED WHEN EXCAVATING NEAR TREES. NO MECHANICAL TRENCHING SHALL BE PERMITTED BELOW THE CANOPY OF EXISTING TREES. CONTRACTOR SHALL ADJUST TRENCH PATH AND/OR EXCAVATE BY HAND TO AVOID DAMAGE TO EXISTING TREE ROOT SYSTEM.
13. CONTRACTOR SHALL COORDINATE AND VERIFY LOCATION OF SIGNAL WIRING, TRAFFIC LOOP DETECTOR WIRING, AND CTMS WIRING PRIOR TO BEGINNING ANY WORK. DAMAGE TO SIGNAL WIRING, LOOP DETECTOR WIRING, CTMS WIRING ANY UTILITIES NOT LISTED, AND STRUCTURES SHALL BE REPAIRED AT CONTRACTOR'S EXPENSE. CONTACT TXDOT SIGNAL SECTION @ 214-320-6683 FOR 'TXDOT LOCATES'.
14. ANY UNDERGROUND UTILITIES, HIGH MAST WIRING, AND CTMS WIRING SHOWN ON PLANS ARE APPROXIMATE LOCATIONS ONLY AND SHALL NOT RELIEVE CONTRACTOR'S RESPONSIBILITY OF COORDINATING WITH APPROPRIATE AUTHORITIES TO LOCATE UNDERGROUND UTILITIES, WIRING AND ANY STRUCTURE.
15. DIG TRENCHES STRAIGHT AND SUPPORT PIPE CONTINUOUSLY ON BOTTOM OF TRENCH INSTALL PIPE TO AN EVEN GRADE. TRENCH BOTTOM SHALL BE CLEAN AND SMOOTH WITH ALL ORGANIC DEBRIS AND SHARP OBJECTS REMOVED. PIPE SHALL BE SNAKED IN TRENCH, TO ALLOW FOR EXPANSION AND CONTRACTION. FOR PUBLIC SAFETY, PLASTIC CONSTRUCTION FENCING, MINIMUM 4 FEET HIGH, SHALL BE USED AROUND OPEN EXCAVATIONS.
16. BORING AND SLEEVE REQUIREMENTS. BORING AND SLEEVE LOCATIONS SHALL BE STAKED FOR ENGINEER'S APPROVAL. BORING DEPTH SHALL BE AT 24" BELOW PAVEMENT. ALL BORINGS AND SLEEVES SHALL BE CONTINUOUS AND SHALL EXTEND THE FULL WIDTH OF THE PAVEMENT AND 5 FEET ON EACH SIDE THEREOF. BORING AND SLEEVES SHALL BE MEASURED AND PAID FOR IN ACCORDANCE WITH ITEM 618. ADDITIONAL PAYMENTS FOR DISTANCES GREATER THAN 5 FEET BEYOND PAVEMENT WILL NOT BE MADE EXCEPT AS ALREADY SHOWN ON PLANS. BORE ENCASUREMENT PIPE MUST BE INSTALLED SAME DAY AS BORING.
17. PVC CASING(S) FOR BORES AND SLEEVES SHALL CONSIST OF SCH 80 SMOOTH WALL PIPE WITH WELDED JOINTS AND SEAMS, AND SHALL BE CONTINUOUS. THE SIZE OF BORE SHALL NOT EXCEED THE DIAMETER OF CASING(S) REQUIRED BY THE PLANS BY MORE THAN 1 INCH.
18. PIPE SHALL NOT BE INSTALLED WHEN AIR TEMPERATURE IS BELOW 40 DEGREES FAHRENHEIT. PLASTIC PIPE SHALL BE CUT IN A MANNER THAT WILL INSURE A SQUARE CUT. BURRS AT CUT ENDS SHALL BE REMOVED PRIOR TO INSTALLATION SO THAT A SMOOTH UNOBSTRUCTED FLOW WILL BE OBTAINED.
19. ALL WATER LINES, VALVES, AND SPRINKLER BODIES SHALL BE THOROUGHLY FLUSHED BEFORE INSTALLING DRIPLINE OR SPRINKLER NOZZLES.
20. CONTROL WIRE AND WIRE CONNECTIONS SHALL BE AS DESCRIBED ON IRRIGATION MATERIALS SPECIFICATIONS CHART. ALL WIRE CONNECTIONS AND SPLICES SHALL BE MADE IN GROUND BOXES.
21. COMPACTION OF THE PIPE TRENCHES MUST BE SUFFICIENT TO LIMIT SHORT TERM SETTING OF THE BACKFILL TO NO MORE THAN 1 INCH. THE CONTRACTOR SHALL CORRECT SETTING GREATER THAN THIS WITHOUT ADDITIONAL COMPENSATION.
22. ALL SPRAY HEADS AND ROTOR HEADS SHALL BE INSTALLED NO CLOSER THAN 6" FROM BACK OF CURB.
24. ALL CONTROL VALVES SHALL HAVE A BALL VALVE INSTALLED ON THE UPSTREAM SIDE OF INLET. ALL CONTROL VALVES AND BALL VALVES SHALL BE LOCATED IN A JUMBO BOX PER SPECIFICATIONS.
25. CONTRACTOR SHALL INSTALL SEPARATE COMMON WIRE FOR EVERY 6 VALVES FOR THE CONTROLLER.

GUARANTEE AND ACCEPTANCE:

26. MAINTENANCE PERIOD. THE IRRIGATION SYSTEM SHALL BE INSPECTED CONCURRENTLY WITH, AND SUBJECT TO THE SAME ESTABLISHMENT/MAINTENANCE REQUIREMENT PERIODS UNDER ITEMS 192 AND 193 (IF USED). DURING THE INSTALLATION, ESTABLISHMENT, AND MAINTENANCE, CONTRACTOR SHALL PERFORM THE FOLLOWING ACTIVITIES AS A MINIMUM AND TO THE SATISFACTION OF THE ENGINEER:
  - A. INSTALL AND MAINTAIN THE CONTROLLER PROGRAM TO INSURE THE PROPER DISTRIBUTION OF WATER (INCLUDES REPLACEMENT OF ANY BATTERIES)
  - B. INSPECT, REPAIR, AND/OR REPLACE ANY EQUIPMENT THAT IS FOUND DEFECTIVE OR MAY BE DAMAGED BY OTHER MAINTENANCE.
  - C. MAKE ANY ADJUSTMENTS THAT MAY BECOME NECESSARY TO ENSURE THE PROPER DELIVERY OF WATER TO THE PLANT MATERIAL.
27. AS-BUILT DRAWINGS. UPON COMPLETION OF THE REQUIRED MAINTENANCE PERIOD, THE ENGINEER WILL MAKE AN INSPECTION OF THE PROJECT. THE CONTRACTOR SHALL FURNISH THE ENGINEER A SET OF AS-BUILT DRAWINGS ON REPRODUCIBLE 11X17 FILM BASE SHEETS. THE ENGINEER WILL CHECK BASE SHEETS TO BE SURE THEY ARE A TRUE RECORD OF THE PROJECT CONDITIONS AND WILL DIRECT THE CONTRACTOR TO CORRECT ANY ERRORS THAT ARE FOUND. THE DRAWINGS SHALL SHOW ALL VALVE LOCATIONS BY TRIANGULATION FROM A FIXED OBJECT AND ANY CHANGE TO SPRINKLER HEAD LOCATION FROM A FIXED OBJECT AND ANY CHANGE TO SPRINKLER HEAD LOCATION AND REROUTING OF MAIN AND LATERAL LINES (CHANGES OF THIS NATURE SHALL BE APPROVED BY THE ENGINEER PRIOR TO INSTALLATION.)
28. OPERATING AND MAINTENANCE DATA. THE CONTRACTOR SHALL PROVIDE INSTRUCTIONS COVERING FULL OPERATION, CARE AND MAINTENANCE OF THE EQUIPMENT, INCLUDING A SCHEDULE SHOWING LENGTH OF TIME EACH VALVE IS TO BE OPEN TO PROVIDE DETERMINED AMOUNT OF WATER, AND INSTRUCT THE STATE'S DESIGNATED PERSONNEL IN PROPER OPERATING OF THE SYSTEM.
29. TEST, TESTING OF THE SYSTEM FOR LEAKAGE SHALL BE IN ACCORDANCE WITH ITEM 170. THE CONTRACTOR SHALL ALSO TEST AND ASSUME THE PROPER ELECTRICAL WORKING ORDER OF THE SYSTEM TO THE SATISFACTION OF THE ENGINEER.

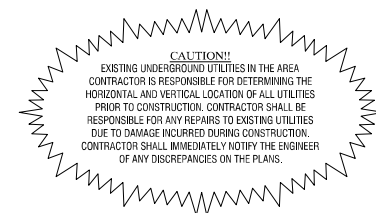

04/05/2024

**Kimley»Horn**

® Texas Registered Engineering Firm F-928

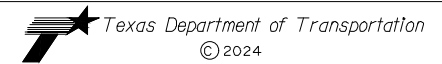

© 2024

**KELLER FM 1709 LANDSCAPE  
ENHANCEMENTS  
GREEN RIBBON PROGRAM PHASE II  
KELLER, TEXAS**

**IRRIGATION GENERAL NOTES**

FED.RD.	PROJECT NO.	HIGHWAY NO.
FM 1709	SEE TITLE SHEET	FM 1709
STATE	DISTRICT	COUNTY
TEXAS	FTW	TARRANT
CONTROL	SECTION	JOB
1603	03	042
		SHEET NO.
		037

PLOTTED BY: PRESLEY, LAURA  
 PLOT DATE: 5/6/2024 2:33 PM  
 LOCATION: K:\FTW\_LALP\061097030\_KELLER GREEN RIBBON PH II\DWG\04 CD\SHEET\9 - IRRIGATION DETAILS.DWG  
 LAST SAVED: 4/8/2024 10:45 AM



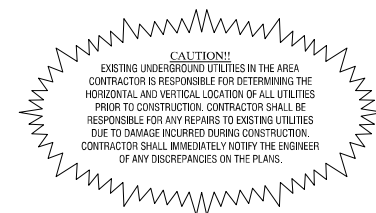

PLOTTED BY: PRESLEY, LAURA  
 PLOT DATE: 5/6/2024 2:33 PM  
 LOCATION: K:\FTW\_LALP\061097030\_KELLER GREEN RIBBON PH II\DWG\04 CD\SHEET\9 - IRRIGATION DETAILS.DWG  
 LAST SAVED: 4/8/2024 10:45 AM

IRRIGATION MATERIALS SPECIFICATIONS			
DESCRIPTION	* EXAMPLE OR EQUAL	SIZE	APPROXIMATE QUANTITIES FOR INFORMATIONAL PURPOSES ONLY
WATER METER	PER LOCAL CODE	1 inch	(4) 1 INCH METERS
RAINBIRD ESPLXME2-LXMM-LXMPED		12 STATION	(4) 12 STATION
RAINBIRD RSD-BEX			(4) RAIN SENSOR
BACKFLOW PREVENTER	FEBCO 825Y (OR PER LOCAL CODE)	1 inch	(4) 1 INCH BACKFLOW PREVENTERS
HUNTER ICZ-101-25 DRIP CONTROL VALVE KIT		1 inch	(6) 1 inch
HUNTER ICV-G MASTER CONTROL VALVE		1 inch	(4) 1 inch
HUNTER ICV-G REMOTE CONTROL VALVE		1 inch	(4) 1 inch
TORO 570S-FB-PC FLOOD BUBBLER			(19) FLOOD BUBBLERS
HUNTER HDL-06-18-PC AREA TO RECEIVE DRIPLINE			MEASURE FROM PLAN.
PVC SCHEDULE 80 CONDUIT Pressure rated with slip type solvent welded joints		4 inch	Paid for under Item 618, See note 16, CONSTRUCTION METHODS and Conduit Installation Details on ED (1)-03.
PVC CLASS 200 MAINLINE Pressure rated with twin gasket couplings and fittings of slip type solvent welded joints.		As indicated on the plans	MEASURE FROM PLAN.
PVC CLASS 200 LATERALS AND HEADERS		As indicated on the plans	MEASURE FROM PLAN.
BURIED RISERS			SHALL BE GREEN 6" CUT OFF RISERS
FITTINGS All fittings incorporated into system shall be of the same type, size and class material as the pipe			AS NEEDED
CONTROL WIRE All low voltage control wire shall be color coded. Wire sizes shall conform to the controller manufacturer specifications for maximum distances for specific wire sizes. All wire shall be specifically manufactured for direct burial. All wire connections and splices shall be made in ground boxes. The splice shall be completely waterproof and shall be completely encapsulated within a Tom King Black Splice Connector enclosure or approved equal.		12 GA (FOR LENGTHS BETWEEN 1200-1600 FEET)  14 GA. (FOR LENGTHS BETWEEN 0-1200 FEET)	PROVIDE WIRE COIL EVERY 100 FEET TO ALLOW FOR EXPANSION. ENSURE MAXIMUM WIRE RUN LENGTHS ARE NOT EXCEEDED. INSTALL COMMON WIRE AS NEEDED PER MANUFACTURER SPECIFICATIONS. INSTALL 4 WIRES FROM EACH ARRAD VALVE TO EACH CONTROLLER.
SOLVENT CEMENT Solvent cement shall be the type recommend by the pipe manufacturer			DO NOT USE BLUE CEMENT. USE A COLORED PRIMER.
VALVE BOXES Boxes for section valves and below-ground backflow preventors, shall be as shown on detail sheet.	DFW Plastics, Inc. DFW65C-14-PKSPSM DFW Plastics, Inc. D1730-18-PKSPSM VALVE BOXES ARE PURPLE BOXES W/ PURPLE BRASS LOCKING ARM LID	BOX SIZE SHALL BE: 17" X 30" X 18" OR 26" X 15" X 14"	QUANTITY AS REQUIRED FOR SECTION VALVES, BELOW GROUND BACKFLOW PREVENTORS AND ANY ACCESSORIES. PROVIDE WEED BARRIER OR FILTER FABRIC AROUND BOXES TO REDUCE SILTATION. TAPE FABRIC IN PLACE AROUND ENTRY POINTS. BOXES SHALL BE PURPLE IN COLOR FOR RECLAIMED WATER.
VALVE BOX RISERS	CONCRETE MASONRY UNIT (CMU) BLOCKS STACKED 2 HIGH AS SHOWN IN DETAILS.	4" X 8" X 16"	QUANTITY AS REQUIRED FOR SECTION VALVES, BELOW GROUND BACKFLOW PREVENTORS, QUICK COUPLING VALVES AND ANY ACCESSORIES
* REFERENCE TO MANUFACTURER'S TRADE NAME OR CATALOG NUMBER IS FOR THE PURPOSE OF IDENTIFICATION ONLY, CONTRACTOR SHALL BE PERMITTED TO FURNISH LIKE MATERIALS OF OTHER MANUFACTURERS PROVIDED THEY ARE OF EQUAL QUALITY AND COMPLY WITH SPECIFICATIONS FOR THIS PROJECT AND ARE APPROVED BY THE ENGINEER.			



04/05/2024

  
 ® Texas Registered Engineering Firm F-928  
  
 © 2024  
**KELLER FM 1709 LANDSCAPE  
 ENHANCEMENTS  
 GREEN RIBBON PROGRAM PHASE II  
 KELLER, TEXAS**  
  
**IRRIGATION SPECIFICATIONS**

FED.RD.	PROJECT NO.	HIGHWAY NO.
FM 1709	SEE TITLE SHEET	FM 1709
STATE	DISTRICT	COUNTY
TEXAS	FTW	TARRANT
CONTROL	SECTION	JOB
1603	03	042

SHEET NO. **038**

PLOTTED BY: PRESLEY, LAURA  
 PLOT DATE: 5/6/2024 2:33 PM  
 LOCATION: K:\FTW\_LALP\061097030\_KELLER GREEN RIBBON PH II\DWG\04 CD\SHEET\11 - EROSION CONTROL.DWG  
 LAST SAVED: 3/20/2024 6:47 PM

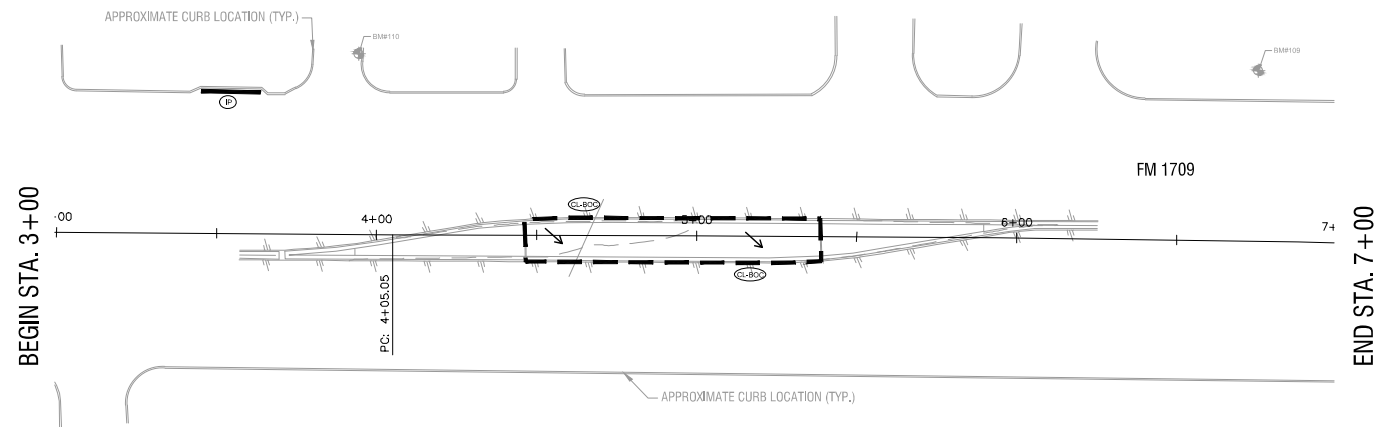

BEGIN STA. 3+00

END STA. 7+00

FM 1709

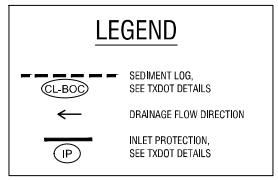

**A** BEGIN STA. 3+00 TO END STA. 7+00  
 PLAN

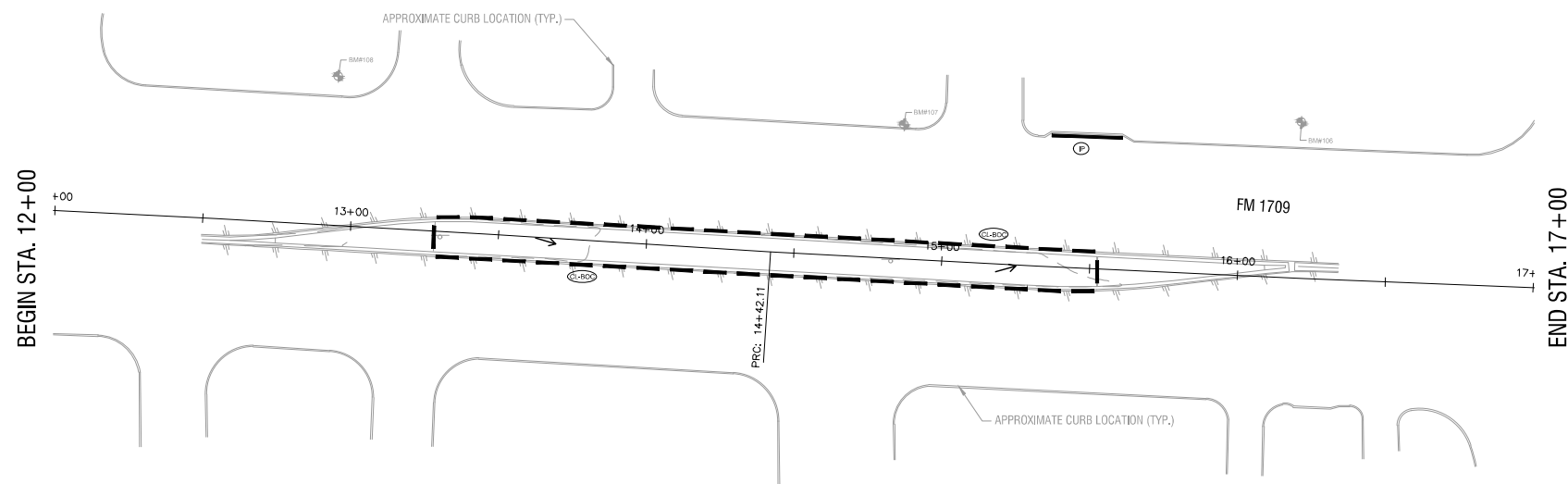

BEGIN STA. 12+00

END STA. 17+00

FM 1709

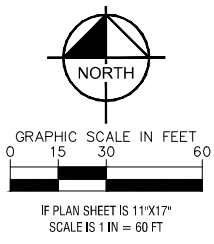

**B** BEGIN STA. 12+00 TO END STA. 17+00  
 PLAN

**CAUTION!**  
 EXISTING UNDERGROUND UTILITIES IN THE AREA  
 CONTRACTOR IS RESPONSIBLE FOR DETERMINING THE  
 HORIZONTAL AND VERTICAL LOCATION OF ALL UTILITIES  
 PRIOR TO CONSTRUCTION. CONTRACTOR SHALL BE  
 RESPONSIBLE FOR ANY REPAIRS TO EXISTING UTILITIES  
 DUE TO DAMAGE INCURRED DURING CONSTRUCTION.  
 CONTRACTOR SHALL IMMEDIATELY NOTIFY THE ENGINEER  
 OF ANY DISCREPANCIES ON THE PLANS.



04/05/2024

**Kimley Horn**

® Texas Registered Engineering Firm F-928

Texas Department of Transportation  
 © 2024

**KELLER FM 1709 LANDSCAPE  
 ENHANCEMENTS  
 GREEN RIBBON PROGRAM PHASE II  
 KELLER, TEXAS**

**EROSION CONTROL PLAN  
 STA. 3+00 TO STA. 7+00  
 STA. 12+00 TO STA. 17+00**

FED.RD.	PROJECT NO.	HIGHWAY NO.
FM 1709	SEE TITLE SHEET	FM 1709
STATE	DISTRICT	COUNTY
TEXAS	FTW	TARRANT
CONTROL	SECTION	JOB
1603	03	042
SHEET NO.		039

PLOTTED BY: PRESLEY, LAURA  
 PLOT DATE: 5/6/2024 2:33 PM  
 LOCATION: K:\FTW\_LALP\061097030\_KELLER GREEN RIBBON PH II\DWG\04\_CD\SHEET\11 - EROSION CONTROL.DWG  
 LAST SAVED: 3/20/2024 6:47 PM

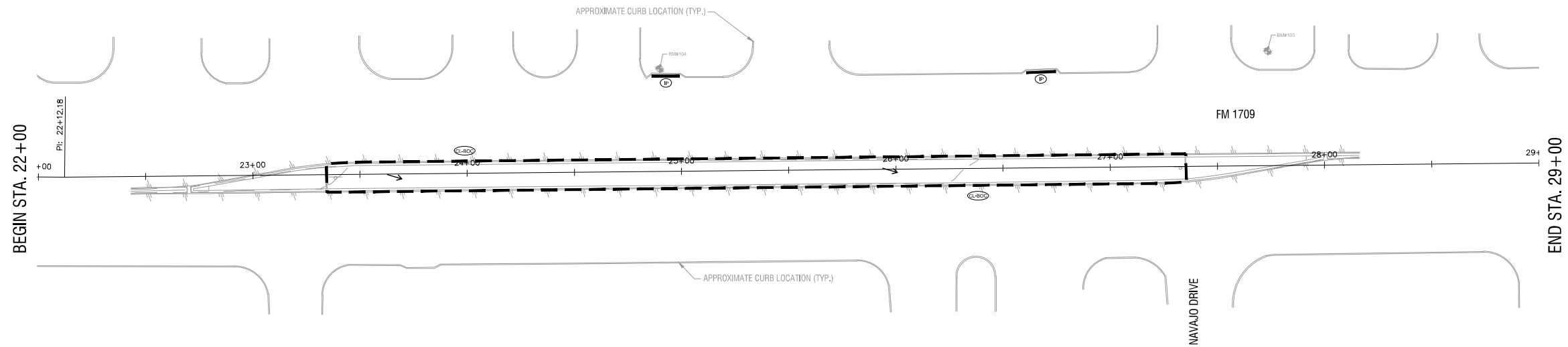

**LEGEND**

- SEDIMENT LOG, SEE TxDOT DETAILS
- DRAINAGE FLOW DIRECTION
- INLET PROTECTION, SEE TxDOT DETAILS

**C** BEGIN STA. 22+00 TO END STA. 29+00  
 PLAN

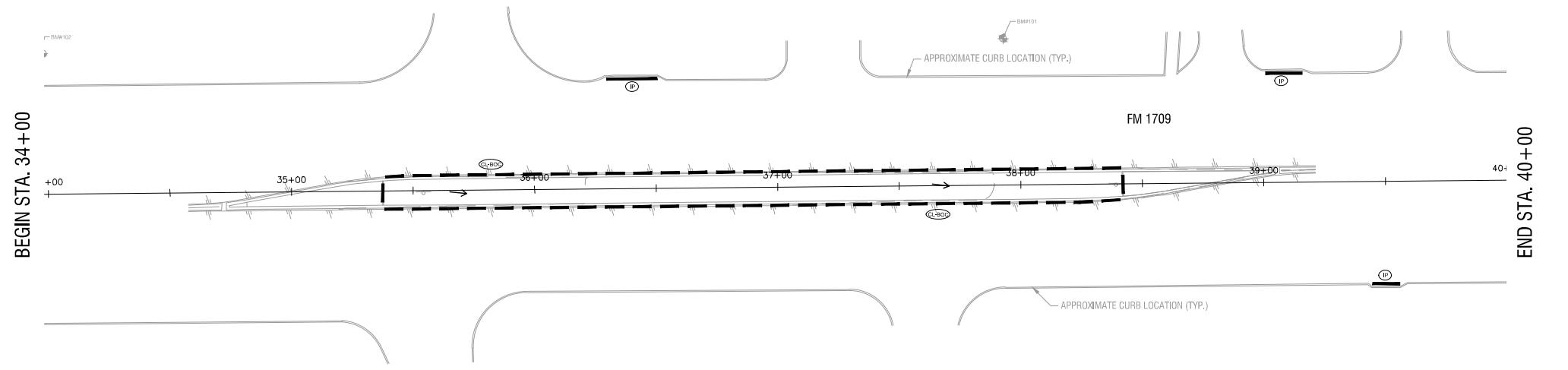

**D** BEGIN STA. 34+00 TO END STA. 40+00  
 PLAN

**CAUTION!**  
 EXISTING UNDERGROUND UTILITIES IN THE AREA CONTRACTOR IS RESPONSIBLE FOR DETERMINING THE HORIZONTAL AND VERTICAL LOCATION OF ALL UTILITIES PRIOR TO CONSTRUCTION. CONTRACTOR SHALL BE RESPONSIBLE FOR ANY REPAIRS TO EXISTING UTILITIES DUE TO DAMAGE INCURRED DURING CONSTRUCTION. CONTRACTOR SHALL IMMEDIATELY NOTIFY THE ENGINEER OF ANY DISCREPANCIES ON THE PLANS.



04/05/2024

**Kimley Horn**

® Texas Registered Engineering Firm F-928

Texas Department of Transportation  
 © 2024

**KELLER FM 1709 LANDSCAPE ENHANCEMENTS GREEN RIBBON PROGRAM PHASE II**  
 KELLER, TEXAS

**EROSION CONTROL PLAN**  
 STA. 22+00 TO STA. 29+00  
 STA. 34+00 TO STA. 40+00

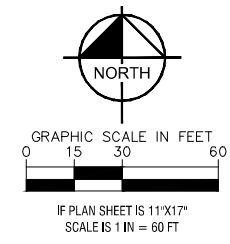

FED.RD.	PROJECT NO.	HIGHWAY NO.	
FM 1709	SEE TITLE SHEET	FM 1709	
STATE	DISTRICT	COUNTY	SHEET NO.
TEXAS	FTW	TARRANT	040
CONTROL	SECTION	JOB	
1603	03	042	

DISCLAIMER: This standard is governed by the "Texas Engineering Practice Act". No warranty of any kind is made by TxDOT for any purpose whatsoever. The use of this standard is governed by the "Texas Engineering Practice Act". No warranty of any kind is made by TxDOT for any purpose whatsoever. TxDOT assumes no responsibility for the conversion of this standard to other formats or for incorrect results or damages resulting from its use.

DATE FILE

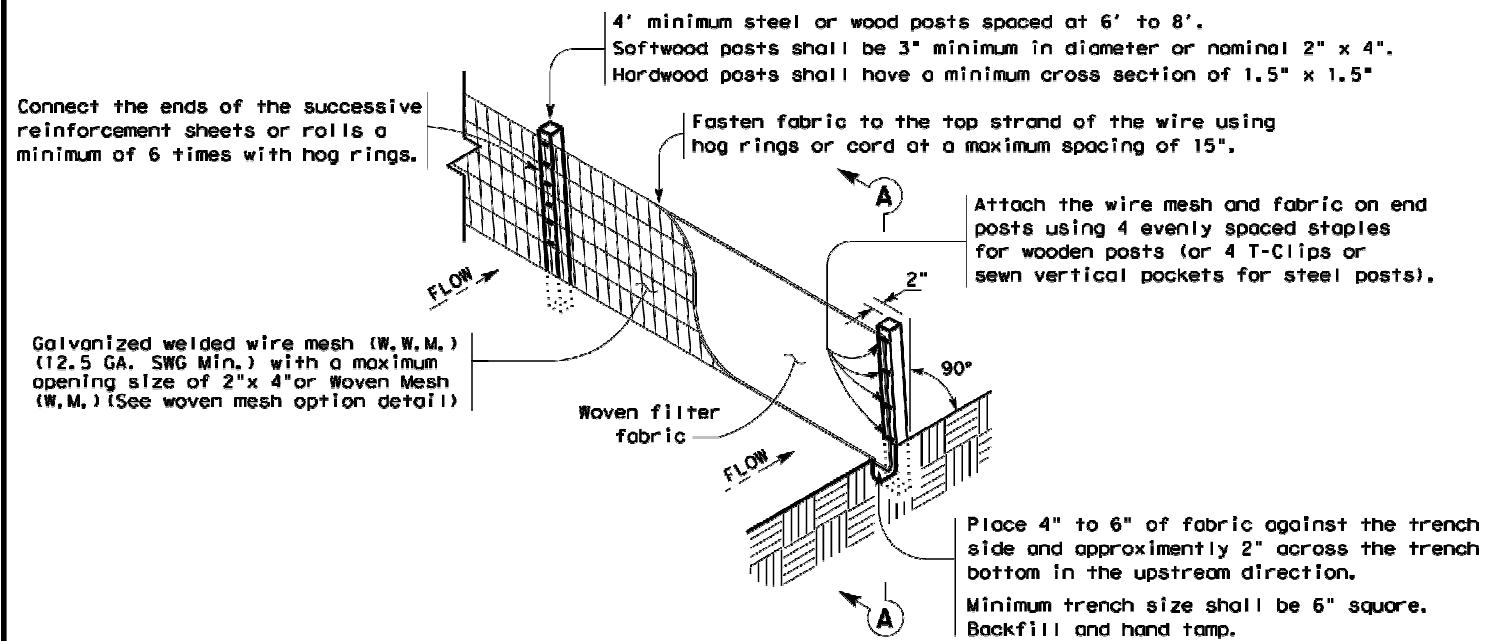

**TEMPORARY SEDIMENT CONTROL FENCE**

SCF

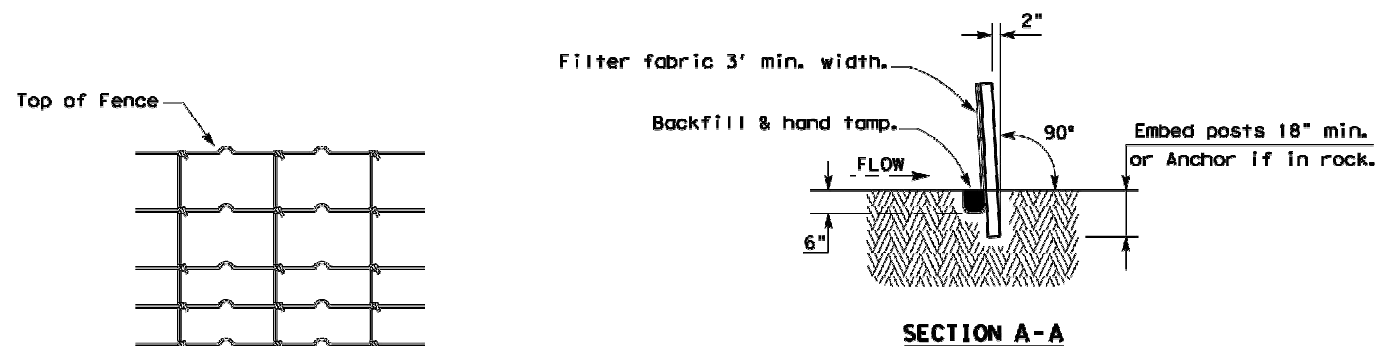

**HINGE JOINT KNOT WOVEN MESH (OPTION) DETAIL**

Galvanized hinge joint knot woven mesh (12.5 GA. SWG Min.) requires a minimum of five horizontal wires spaced at a maximum of 12 inches apart and all vertical wires spaced at a maximum of 12 inches apart.

**SEDIMENT CONTROL FENCE USAGE GUIDELINES**

A sediment control fence may be constructed near the downstream perimeter of a disturbed area along a contour to intercept sediment from overland runoff. A 2 year storm frequency may be used to calculate the flow rate to be filtered.

Sediment control fence should be sized to filter a maximum flow through rate of 100 GPM/FT<sup>2</sup>. Sediment control fence is not recommended to control erosion from a drainage area larger than 2 acres.

**LEGEND**

Sediment Control Fence

SCF

**GENERAL NOTES**

1. Vertical tracking is required on projects where soil distributing activities have occurred unless otherwise approved.
2. Perform vertical tracking on slopes to temporarily stabilize soil.
3. Provide equipment with a track undercarriage capable of producing linear soil impressions measuring a minimum of 12" in length by 2" to 4" in width by 1/2" to 2" in depth.
4. Do not exceed 12" between track impressions.
5. Install continuous linear track impressions where the minimum 12" length impressions are perpendicular to the slope or direction of water flow.

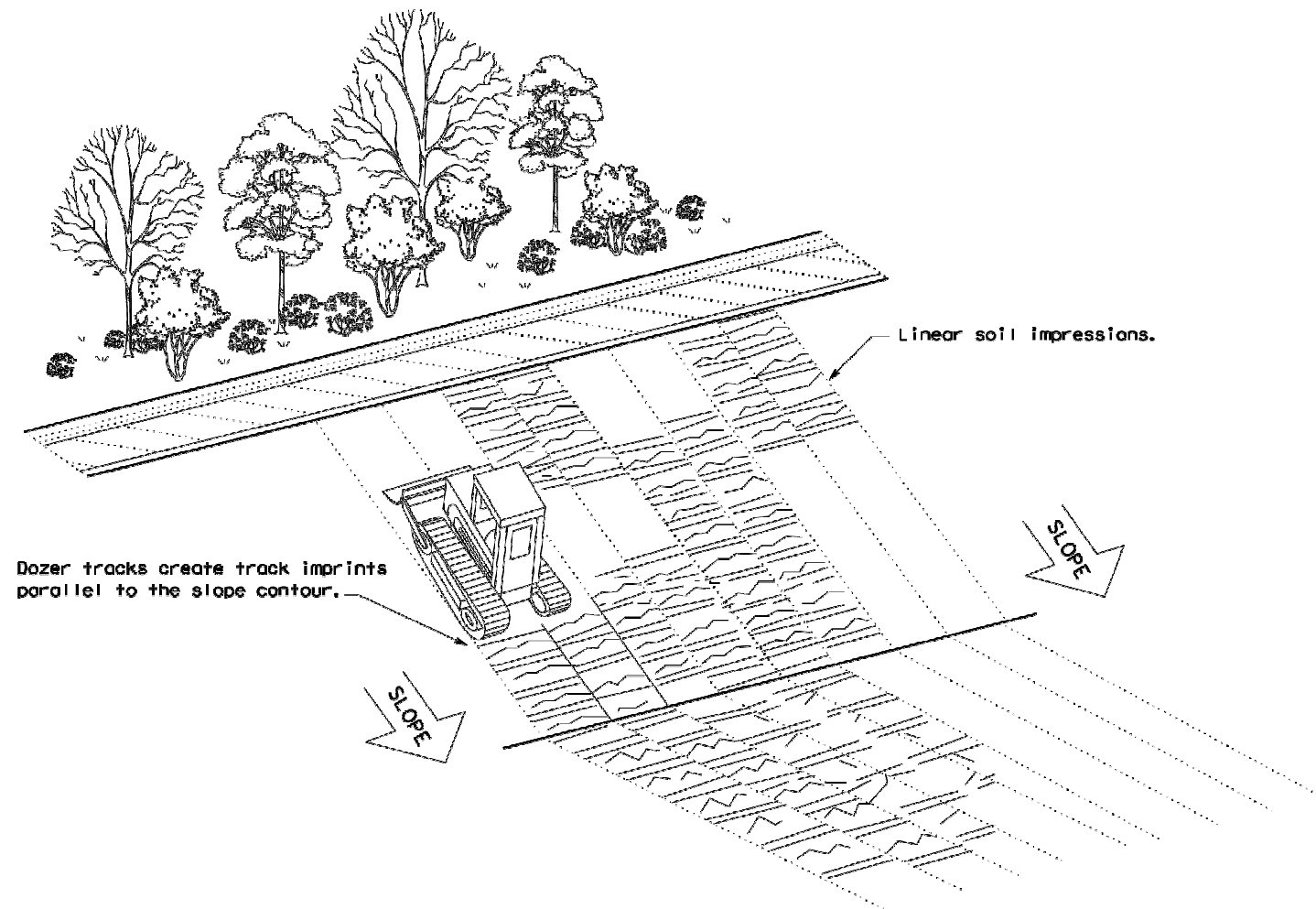

**VERTICAL TRACKING**



**TEMPORARY EROSION, SEDIMENT AND WATER POLLUTION CONTROL MEASURES FENCE & VERTICAL TRACKING EC(1) - 16**

FILE: ec116	DN: TxDOT	CR: KM	DM: VP	DN/CR: LS
© TxDOT: JULY 2016	CONT	SECT	JOB	HIGHWAY
REVISIONS	1603	03	042	FM 1709
	DIST	COUNTY		SHEET NO.
	FTW	TARRANT		041

DISCLAIMER: The use of this standard is governed by the "Texas Engineering Practice Act". No warranty of any kind is made by TxDOT for any purpose whatsoever. TxDOT assumes no responsibility for the conversion of this standard to other formats or for incorrect results or damages resulting from its use.

DATE: FILE:

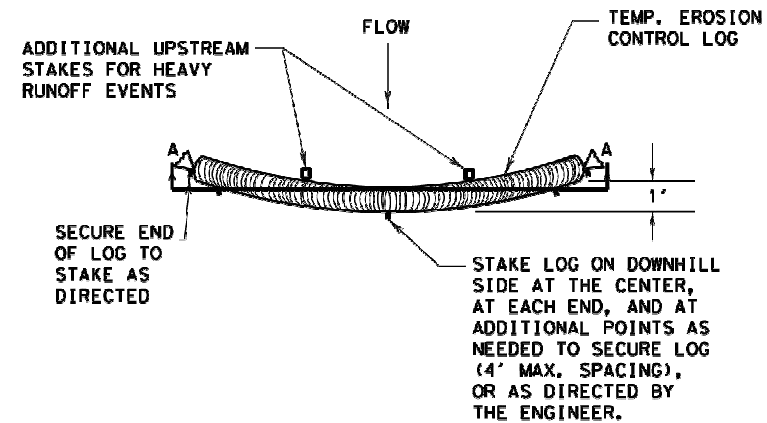

PLAN VIEW

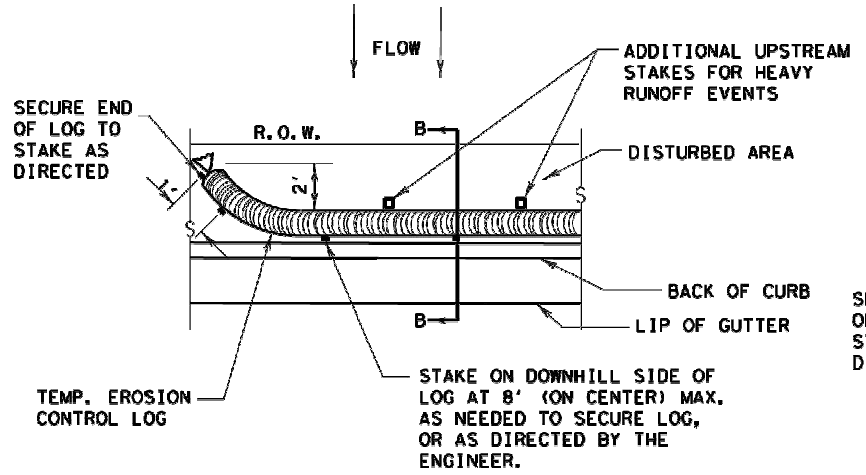

PLAN VIEW

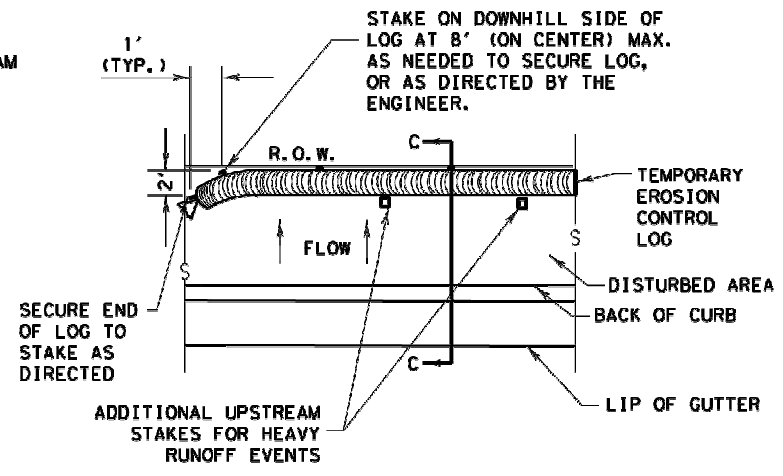

PLAN VIEW

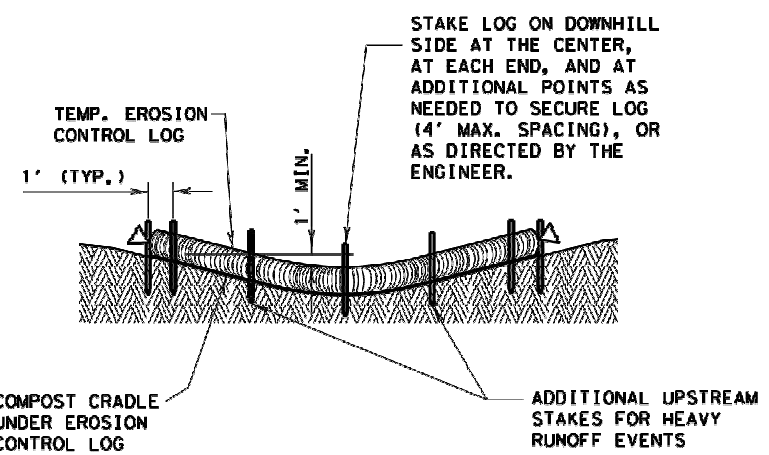

SECTION A-A

EROSION CONTROL LOG DAM

CL-D

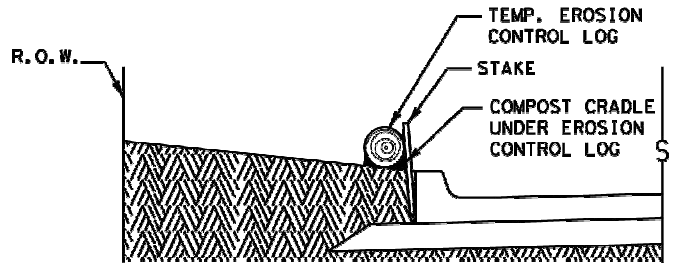

SECTION B-B

EROSION CONTROL LOG AT BACK OF CURB

CL-BOC

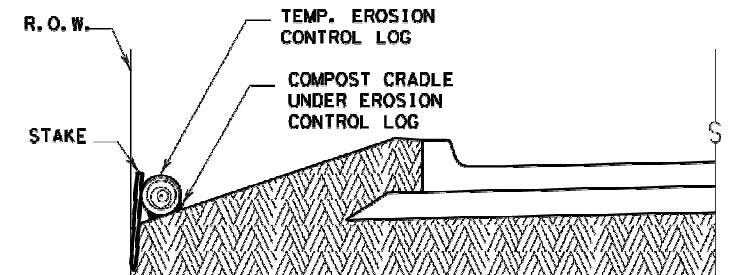

SECTION C-C

EROSION CONTROL LOG AT EDGE OF RIGHT-OF-WAY

CL-ROW

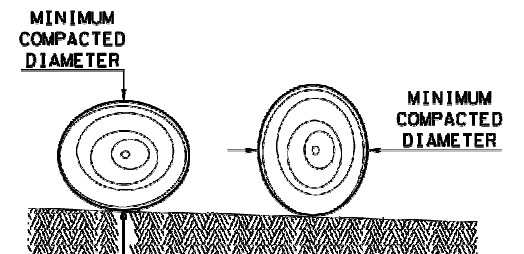

DIAMETER MEASUREMENTS OF EROSION CONTROL LOGS SPECIFIED IN PLANS

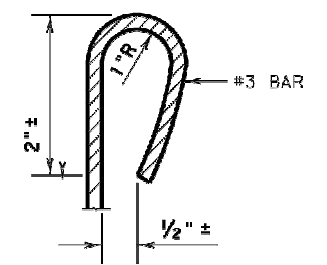

REBAR STAKE DETAIL

**SEDIMENT BASIN & TRAP USAGE GUIDELINES**

An erosion control log sediment trap may be used to filter sediment out of runoff draining from an unstabilized area.

**Log Traps:** The drainage area for a sediment trap should not exceed 5 acres. The trap capacity should be 1800 CF/Acre (0.5" over the drainage area).

Control logs should be placed in the following locations:

1. Within drainage ditches spaced as needed or min. 500' on center
2. Immediately preceding ditch inlets or drain inlets
3. Just before the drainage enters a water course
4. Just before the drainage leaves the right of way
5. Just before the drainage leaves the construction limits where drainage flows away from the project.

The logs should be cleaned when the sediment has accumulated to a depth of 1/2 the log diameter.

Cleaning and removal of accumulated sediment deposits is incidental and will not be paid for separately.

**GENERAL NOTES:**

1. EROSION CONTROL LOGS SHALL BE INSTALLED IN ACCORDANCE WITH MANUFACTURER'S RECOMMENDATIONS, OR AS DIRECTED BY THE ENGINEER.
2. LENGTHS OF EROSION CONTROL LOGS SHALL BE IN ACCORDANCE WITH MANUFACTURER'S RECOMMENDATIONS AND AS REQUIRED FOR THE PURPOSE INTENDED.
3. UNLESS OTHERWISE DIRECTED, USE BIODEGRADABLE OR PHOTODEGRADABLE CONTAINMENT MESH ONLY WHERE LOG WILL REMAIN IN PLACE AS PART OF A VEGETATIVE SYSTEM. FOR TEMPORARY INSTALLATIONS, USE RECYCLABLE CONTAINMENT MESH.
4. FILL LOGS WITH SUFFICIENT FILTER MATERIAL TO ACHIEVE THE MINIMUM COMPACTED DIAMETER SPECIFIED IN THE PLANS WITHOUT EXCESSIVE DEFORMATION.
5. STAKES SHALL BE 2" X 2" WOOD OR #3 REBAR, 2'-4' LONG, EMBEDDED SUCH THAT 2" PROTRUDES ABOVE LOG, OR AS DIRECTED BY THE ENGINEER.
6. DO NOT PLACE STAKES THROUGH CONTAINMENT MESH.
7. COMPOST CRADLE MATERIAL IS INCIDENTAL & WILL NOT BE PAID FOR SEPARATELY.
8. SANDBAGS USED AS ANCHORS SHALL BE PLACED ON TOP OF LOGS & SHALL BE OF SUFFICIENT SIZE TO HOLD LOGS IN PLACE.
9. TURN THE ENDS OF EACH ROW OF LOGS UPSLOPE TO PREVENT RUNOFF FROM FLOWING AROUND THE LOG.
10. FOR HEAVY RUNOFF EVENTS, ADDITIONAL UPSTREAM STAKES MAY BE NECESSARY TO KEEP LOG FROM FOLDING IN ON ITSELF.

SHEET 1 OF 3

		<b>Design Division Standard</b>	
<b>TEMPORARY EROSION, SEDIMENT AND WATER POLLUTION CONTROL MEASURES</b>			
<b>EROSION CONTROL LOG</b>			
<b>EC (9) - 16</b>			
FILE# ec916	DATE TxDOT	CHK# KM	DWG# LS/PJT
© TxDOT# JULY 2016	CONF# SECT	JOB	HIGHWAY
REVISIONS	1603 03	042	FM 1709
	DIST#	COUNTY	SHEET NO.
	FTW	TARRANT	042

DISCLAIMER: The use of this standard is governed by the "Texas Engineering Practice Act". No warranty of any kind is made by TxDOT for any purpose whatsoever. TxDOT assumes no responsibility for the conversion of this standard to other formats or for incorrect results or damages resulting from its use.

DATE: FILE:

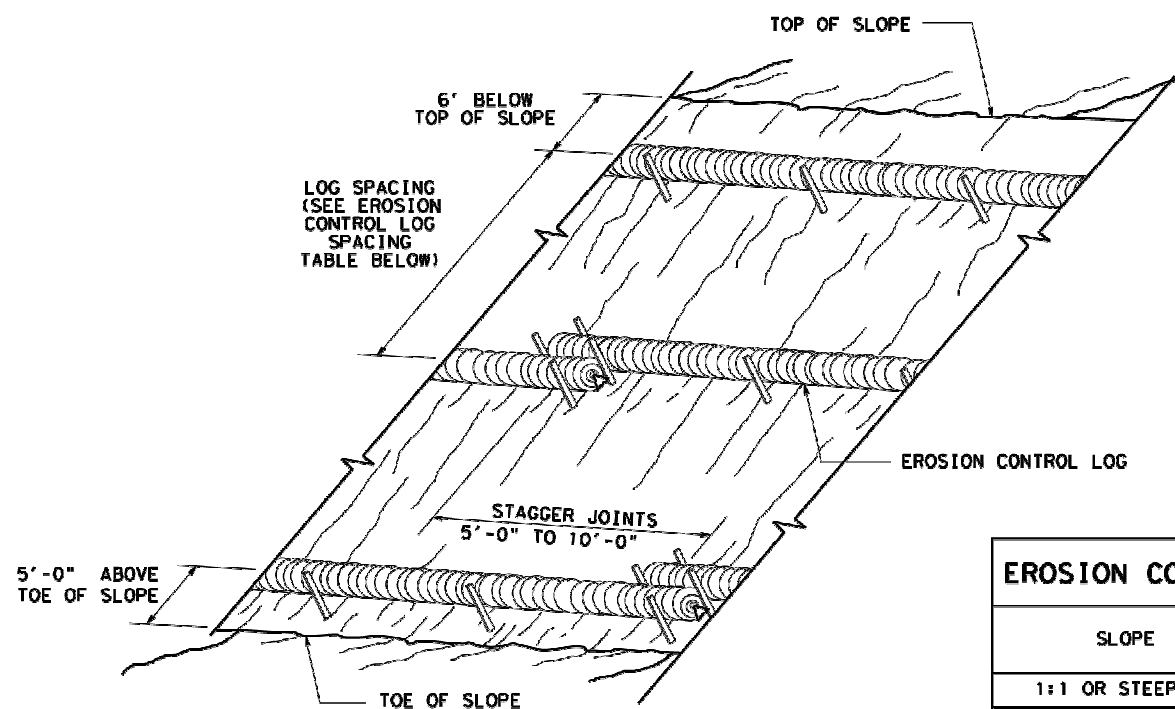

**EROSION CONTROL LOGS ON SLOPES  
STAKE AND TRENCHING ANCHORING**

CL-SST

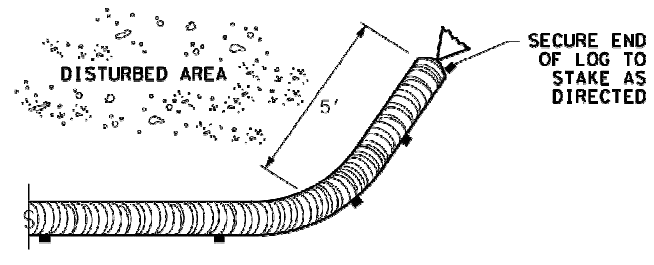

**END SECTION RAP DETAIL**

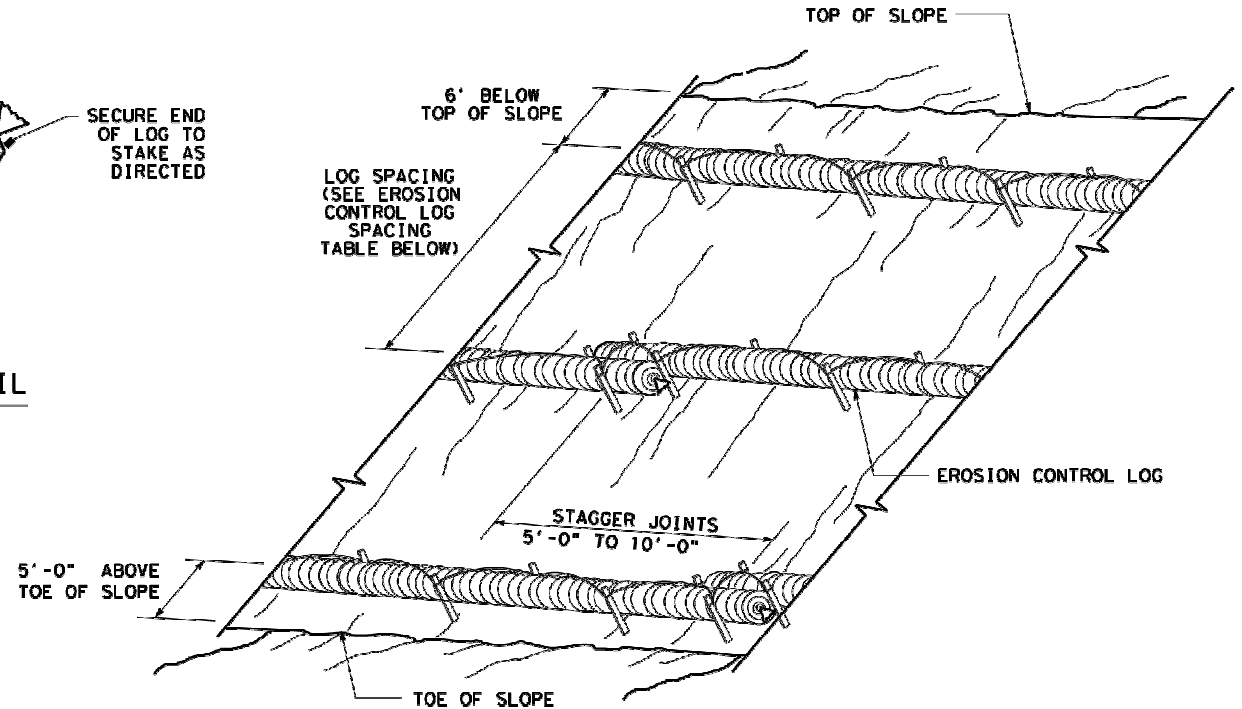

**EROSION CONTROL LOGS ON SLOPES  
STAKE AND LASHING ANCHORING**

CL-SSL

SLOPE	LOG DIAMETER			
	6"	8"	12"	18"
1:1 OR STEEPER	5'	10'	15'	20'
2:1	10'	20'	30'	40'
3:1	15'	30'	45'	60'
4:1 OR FLATTER	20'	40'	60'	80'

\* ADJUSTMENTS CAN BE MADE FOR SOIL TYPE:  
 SOFT, LOAMY SOILS-ADJUST ROWS CLOSER TOGETHER;  
 HARD, ROCKY SOILS- ADJUST ROWS FARTHER APART

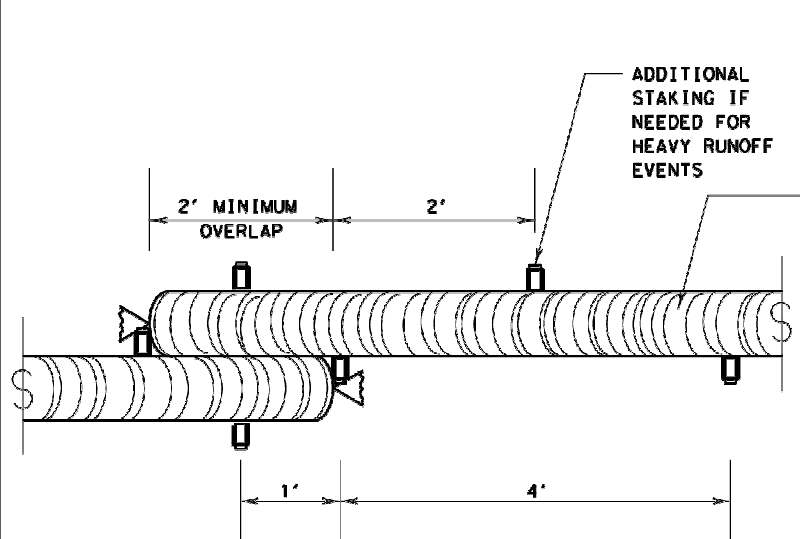

**STAKE AND TRENCHING ANCHORING DETAIL**

CL-SST

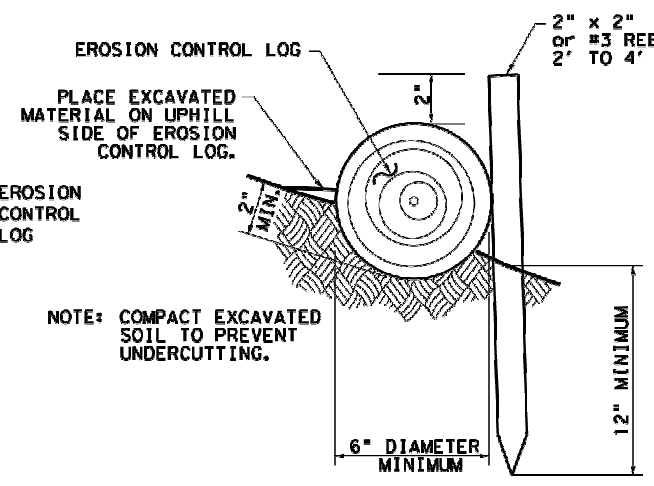

NOTE: COMPACT EXCAVATED SOIL TO PREVENT UNDERCUTTING.

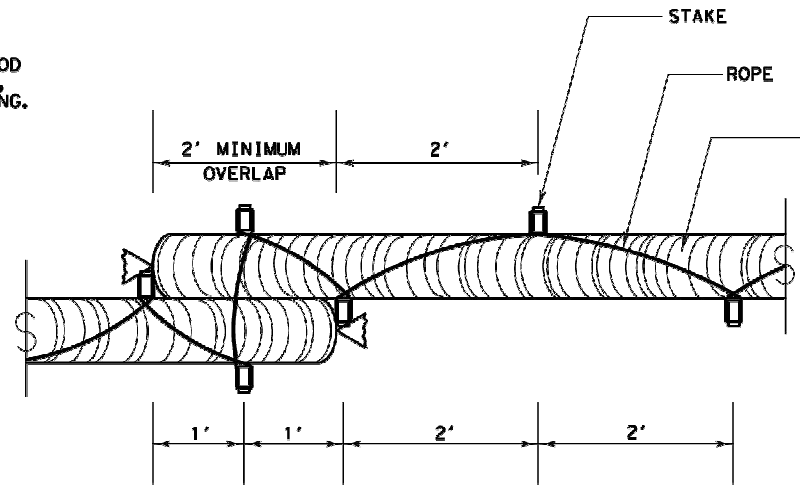

**STAKE AND LASHING ANCHORING DETAIL**

CL-SSL

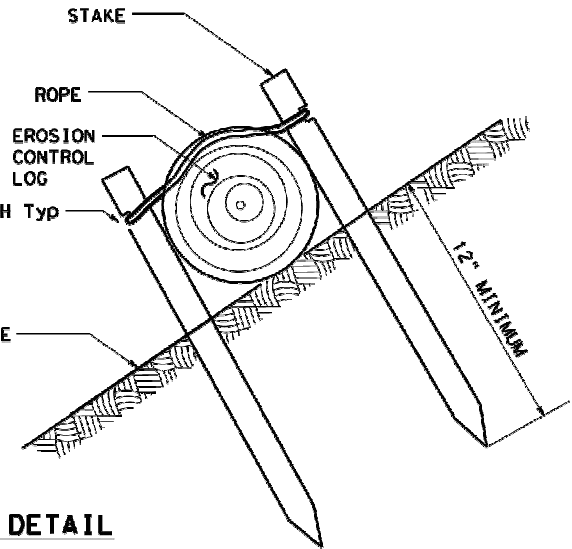

LOG DIAMETER	DEPTH
6"	2"
8"	3"
12"	4"
18"	5"

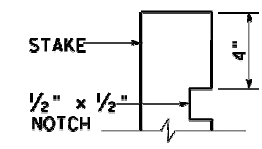

**STAKE NOTCH DETAIL**

SHEET 2 OF 3

		<b>Design Division Standard</b>	
<b>TEMPORARY EROSION, SEDIMENT AND WATER POLLUTION CONTROL MEASURES</b> <b>EROSION CONTROL LOG</b> <b>EC (9) - 16</b>			
FILE: ec116	DN: TxDOT	CR: KM	DR: LS/PJ
© TxDOT: JULY 2016	CONT: 03	JOB: 042	HIGHWAY: FM 1709
REVISIONS	DIST: FTW	COUNTY: TARRANT	SHEET NO: 043

DISCLAIMER: This standard is governed by the "Texas Engineering Practice Act". No warranty of any kind is made by TxDOT for any purpose whatsoever. TxDOT assumes no responsibility for the conversion of this standard to other formats or for incorrect results or damages resulting from its use.

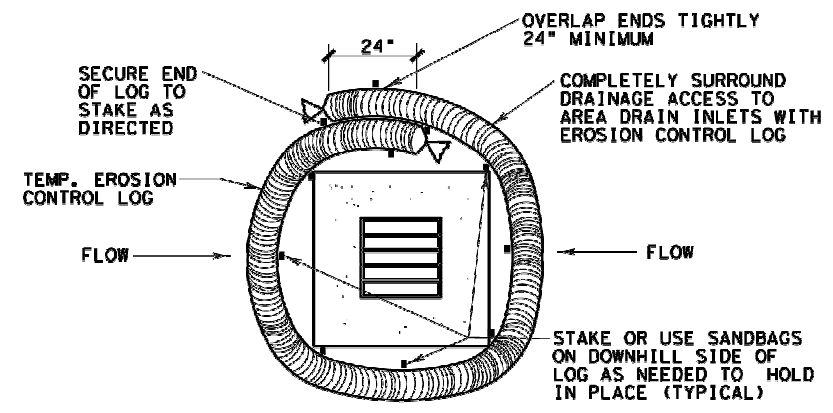

**EROSION CONTROL LOG AT DROP INLET**

CL-DI

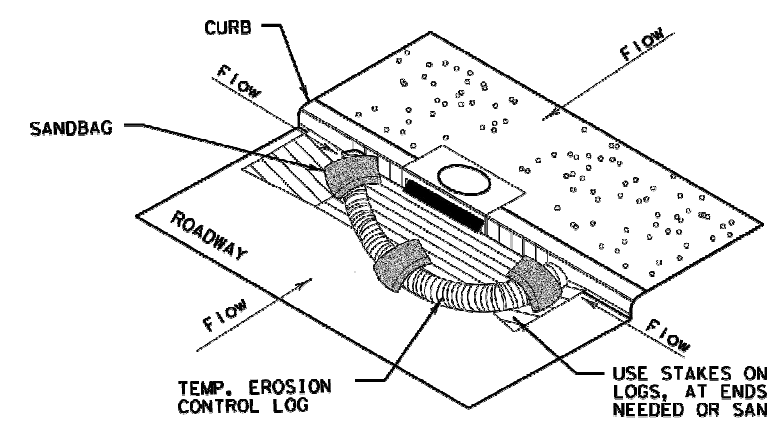

**EROSION CONTROL LOG AT CURB INLET**

CL-CI

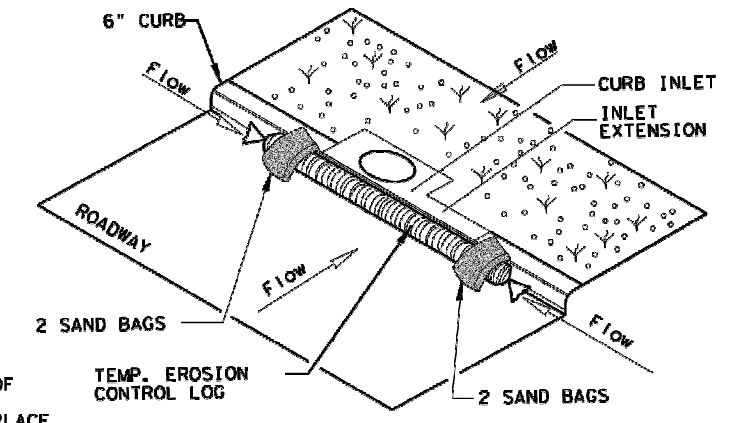

**EROSION CONTROL LOG AT CURB INLET**

CL-CI

NOTE:  
EROSION CONTROL LOGS USED AT CURB INLETS SHOULD ONLY BE USED IF THEY WILL NOT IMPEDE TRAFFIC OR FLOOD THE ROADWAY OR WHEN THE STORM SEWER SYSTEM IS NOT FULLY FUNCTIONAL.

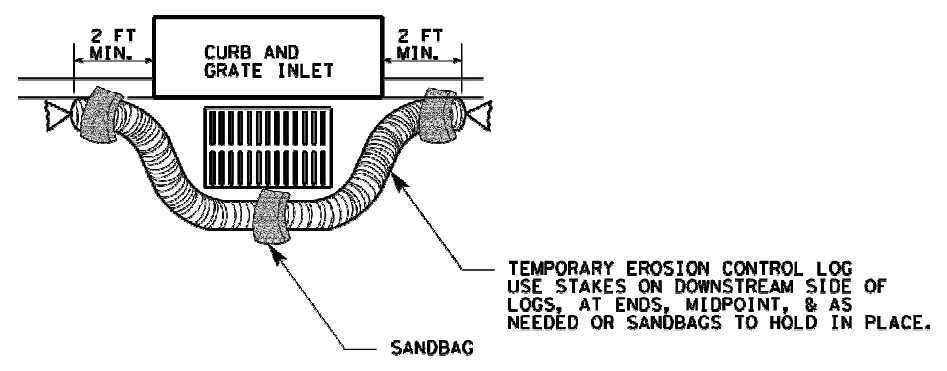

**EROSION CONTROL LOG AT CURB & GRADE INLET**

CL-GI

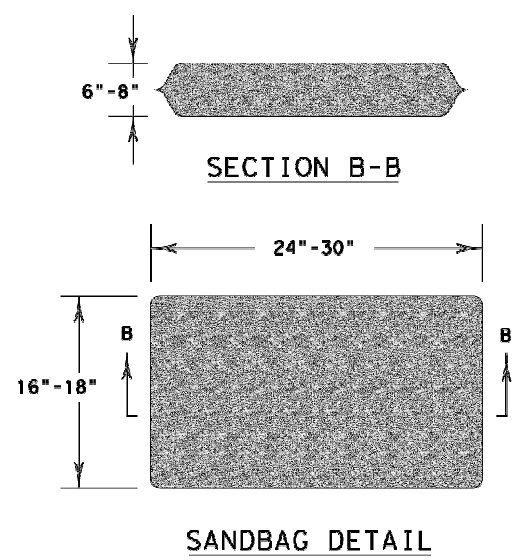

SHEET 3 OF 3

		<b>Design Division Standard</b>	
<b>TEMPORARY EROSION, SEDIMENT AND WATER POLLUTION CONTROL MEASURES</b> <b>EROSION CONTROL LOG</b> <b>EC (9) - 16</b>			
FILE: ec816	DN: TxDOT	CR: KM	DM: LS/PT
© TxDOT: JULY 2016	CONT: 1603	SECT: 03	JOB: 042
REVISIONS	DIST: FTW	COUNTY: TARRANT	SHEET NO: 044

DATE:  
FILE:

DISCLAIMER: The use of this standard is governed by the "Texas Engineering Practice Act". No warranty of any kind is made by TxDOT for any purpose whatsoever. TxDOT assumes no responsibility for the conversion of this standard to other formats or for incorrect results or damages resulting from its use.

DATE: FILE:

**I. STORMWATER POLLUTION PREVENTION-CLEAN WATER ACT SECTION 402**

TPDES TXR 150000: Stormwater Discharge Permit or Construction General Permit required for projects with 1 or more acres disturbed soil. Projects with any disturbed soil must protect for erosion and sedimentation in accordance with Item 506.

List MS4 Operator(s) that may receive discharges from this project. They may need to be notified prior to construction activities.

1.  
2.
- No Action Required     Required Action

Action No.

1. Prevent stormwater pollution by controlling erosion and sedimentation in accordance with TPDES Permit TXR 150000
2. Comply with the SW3P and revise when necessary to control pollution or required by the Engineer.
3. Post Construction Site Notice (CSN) with SW3P information on or near the site, accessible to the public and TCEQ, EPA or other inspectors.
4. When Contractor project specific locations (PSL's) increase disturbed soil area to 5 acres or more, submit NOI to TCEQ and the Engineer.

**II. WORK IN OR NEAR STREAMS, WATERBODIES AND WETLANDS CLEAN WATER ACT SECTIONS 401 AND 404**

USACE Permit required for filling, dredging, excavating or other work in any water bodies, rivers, creeks, streams, wetlands or wet areas.

The Contractor must adhere to all of the terms and conditions associated with the following permit(s):

- No Permit Required
- Nationwide Permit 14 - PCN not Required (less than 1/10th acre waters or wetlands affected)
- Nationwide Permit 14 - PCN Required (1/10 to <1/2 acre, 1/3 in tidal waters)
- Individual 404 Permit Required
- Other Nationwide Permit Required: NWP# \_\_\_\_\_

Required Actions: List waters of the US permit applies to, location in project and check Best Management Practices planned to control erosion, sedimentation and post-project TSS.

1.  
2.  
3.  
4.

The elevation of the ordinary high water marks of any areas requiring work to be performed in the waters of the US requiring the use of a nationwide permit can be found on the Bridge Layouts.

**Best Management Practices:**

<b>Erosion</b>	<b>Sedimentation</b>	<b>Post-Construction TSS</b>
<input type="checkbox"/> Temporary Vegetation	<input type="checkbox"/> Silt Fence	<input type="checkbox"/> Vegetative Filter Strips
<input type="checkbox"/> Blankets/Matting	<input type="checkbox"/> Rock Berm	<input checked="" type="checkbox"/> Retention/Irrigation Systems
<input type="checkbox"/> Mulch	<input type="checkbox"/> Triangular Filter Dike	<input type="checkbox"/> Extended Detention Basin
<input type="checkbox"/> Sodding	<input type="checkbox"/> Sand Bag Berm	<input type="checkbox"/> Constructed Wetlands
<input type="checkbox"/> Interceptor Swale	<input type="checkbox"/> Straw Bale Dike	<input type="checkbox"/> Wet Basin
<input type="checkbox"/> Diversion Dike	<input type="checkbox"/> Brush Berms	<input type="checkbox"/> Erosion Control Compost
<input type="checkbox"/> Erosion Control Compost	<input type="checkbox"/> Erosion Control Compost	<input type="checkbox"/> Mulch Filter Berm and Socks
<input checked="" type="checkbox"/> Mulch Filter Berm and Socks	<input checked="" type="checkbox"/> Mulch Filter Berm and Socks	<input type="checkbox"/> Compost Filter Berm and Socks
<input type="checkbox"/> Compost Filter Berm and Socks	<input type="checkbox"/> Compost Filter Berm and Socks	<input type="checkbox"/> Vegetation Lined Ditches
	<input type="checkbox"/> Stone Outlet Sediment Traps	<input type="checkbox"/> Sand Filter Systems
	<input type="checkbox"/> Sediment Basins	<input type="checkbox"/> Grassy Swales

**III. CULTURAL RESOURCES**

Refer to TxDOT Standard Specifications in the event historical issues or archeological artifacts are found during construction. Upon discovery of archeological artifacts (bones, burnt rock, flint, pottery, etc.) cease work in the immediate area and contact the Engineer immediately.

- No Action Required     Required Action

Action No.

1.  
2.  
3.  
4.

**IV. VEGETATION RESOURCES**

Preserve native vegetation to the extent practical. Contractor must adhere to Construction Specification Requirements Specs 162, 164, 192, 193, 506, 730, 751, 752 in order to comply with requirements for invasive species, beneficial landscaping, and tree/brush removal commitments.

- No Action Required     Required Action

Action No.

1.  
2.  
3.  
4.

**V. FEDERAL LISTED, PROPOSED THREATENED, ENDANGERED SPECIES, CRITICAL HABITAT, STATE LISTED SPECIES, CANDIDATE SPECIES AND MIGRATORY BIRDS.**

- No Action Required     Required Action

Action No.

1.  
2.  
3.  
4.

If any of the listed species are observed, cease work in the immediate area, do not disturb species or habitat and contact the Engineer immediately. The work may not remove active nests from bridges and other structures during nesting season of the birds associated with the nests. If caves or sinkholes are discovered, cease work in the immediate area, and contact the Engineer immediately.

**LIST OF ABBREVIATIONS**

BMP: Best Management Practice	SPCC: Spill Prevention Control and Countermeasure
CGP: Construction General Permit	SW3P: Storm Water Pollution Prevention Plan
DSHS: Texas Department of State Health Services	PCN: Pre-Construction Notification
FHWA: Federal Highway Administration	PSL: Project Specific Location
MOA: Memorandum of Agreement	TCEQ: Texas Commission on Environmental Quality
MOU: Memorandum of Understanding	TPDES: Texas Pollutant Discharge Elimination System
MS4: Municipal Separate Stormwater Sewer System	TPWD: Texas Parks and Wildlife Department
MTA: Migratory Bird Treaty Act	TxDOT: Texas Department of Transportation
NOT: Notice of Termination	TBE: Threatened and Endangered Species
NWP: Nationwide Permit	USACE: U.S. Army Corps of Engineers
NOI: Notice of Intent	USFWS: U.S. Fish and Wildlife Service

**VI. HAZARDOUS MATERIALS OR CONTAMINATION ISSUES**

General (applies to all projects):

Comply with the Hazard Communication Act (the Act) for personnel who will be working with hazardous materials by conducting safety meetings prior to beginning construction and making workers aware of potential hazards in the workplace. Ensure that all workers are provided with personal protective equipment appropriate for any hazardous materials used. Obtain and keep on-site Material Safety Data Sheets (MSDS) for all hazardous products used on the project, which may include, but are not limited to the following categories: Paints, acids, solvents, asphalt products, chemical additives, fuels and concrete curing compounds or additives. Provide protected storage, off bare ground and covered, for products which may be hazardous. Maintain product labelling as required by the Act. Maintain an adequate supply of on-site spill response materials, as indicated in the MSDS. In the event of a spill, take actions to mitigate the spill as indicated in the MSDS, in accordance with safe work practices, and contact the District Spill Coordinator immediately. The Contractor shall be responsible for the proper containment and cleanup of all product spills.

Contact the Engineer if any of the following are detected:

- \* Dead or distressed vegetation (not identified as normal)
- \* Trash piles, drums, canister, barrels, etc.
- \* Undesirable smells or odors
- \* Evidence of leaching or seepage of substances

Does the project involve any bridge class structure rehabilitation or replacements (bridge class structures not including box culverts)?

- Yes     No

If "No", then no further action is required.

If "Yes", then TxDOT is responsible for completing asbestos assessment/inspection.

Are the results of the asbestos inspection positive (is asbestos present)?

- Yes     No

If "Yes", then TxDOT must retain a DSHS licensed asbestos consultant to assist with the notification, develop abatement/mitigation procedures, and perform management activities as necessary. The notification form to DSHS must be postmarked at least 15 working days prior to scheduled demolition.

If "No", then TxDOT is still required to notify DSHS 15 working days prior to any scheduled demolition.

In either case, the Contractor is responsible for providing the date(s) for abatement activities and/or demolition with careful coordination between the Engineer and asbestos consultant in order to minimize construction delays and subsequent claims.

Any other evidence indicating possible hazardous materials or contamination discovered on site. Hazardous Materials or Contamination Issues Specific to this Project:

- No Action Required     Required Action

Action No.

1.  
2.  
3.

**VII. OTHER ENVIRONMENTAL ISSUES**

(includes regional issues such as Edwards Aquifer District, etc.)

- No Action Required     Required Action

Action No.

1.  
2.  
3.

**Design Division Standard**

## ENVIRONMENTAL PERMITS, ISSUES AND COMMITMENTS

# EPIC

FILE: epic.dgn	DNR: TxDOT	CR: RG	DW: VP	CR: AR
©TxDOT: February 2015	CONT: 1603	SECT: 03	JOB: 042	HIGHWAY: FM 1709
12-12-2011 (DS) REVISED	DIST: FTW	COUNTY: TARRANT	SHEET NO.: 045	
<small>08-07-14 ADDD NOTE SECTION IV. 01-25-2015 SECTION I (CHANGED ITEM 1122 TO 1159 506, ADDED GRASSY SWALES.</small>				



04/05/2024



**STORMWATER POLLUTION PREVENTION PLAN (SWP3):**

This SWP3 has been developed in accordance with TxDOT policy for projects disturbing less than 1 acre of soil, and not part of a larger common plan of development.

For all projects with any soil disturbing activities, TxDOT will maintain a SWP3 with all pertinent records, correspondence, environmental documents, etc. at the project field office. If no field office is available, then this SWP3 shall be kept at the appropriate TxDOT Area Office.

This SWP3 is consistent with requirements specified in applicable stormwater plans, and the project's environmental permits, issues, and commitments (EPICs).

**1.0 SITE/PROJECT DESCRIPTION**

**1.1 PROJECT CONTROL SECTION JOB (CSJ):**

1603-03-042

**1.2 PROJECT LIMITS:**

From: College Avenue

To: Meadowlands Boulevard

**1.3 PROJECT COORDINATES:**

BEGIN: (Lat) 32.934524, (Long) -97.248653

END: (Lat) 32.934309, (Long) -97.236573

**1.4 TOTAL PROJECT AREA (Acres):** 7.3 acres

**1.5 TOTAL AREA TO BE DISTURBED (Acres):** 0.18 acres

**1.6 NATURE OF CONSTRUCTION ACTIVITY:**

LANDSCAPE WORK, HARDSCAPE, IRRIGATION, AND PLANTING

**1.7 MAJOR SOIL TYPES:**

Soil Type	Description
SnC	SANGER-URBAN LAND COMPLEX, 1 TO 5% SLOPES
WuA	WILSON-URBAN LAND COMPLEX, 0 TO 2% SLOPES

**1.8 PROJECT SPECIFIC LOCATIONS (PSLs):**

PSLs must be depicted on the Environmental Layout Sheets in Attachment 1.2 of this SWP3. PSLs may be identified during preconstruction meetings or during the construction process. Please choose from the options below:

- PSLs determined during preconstruction meeting
- PSLs determined during construction
- No PSLs planned for construction

Type	Sheet #s

All off-ROW PSLs required by the Contractor are the Contractor's responsibility. The Contractor shall secure all permits required by local, state, federal laws for off-ROW PSLs. The contractor shall provide diagrams, areas of disturbance, acreage, and BMPs for all off-ROW PSLs within one mile of the project.

**1.9 CONSTRUCTION ACTIVITIES:**

(Use the following list as a starting point when developing the Construction Activity Schedule and Ceasing Record in Attachment 2.3.)

- Mobilization
- Install sediment and erosion controls
  - Blade existing topsoil into windrows, prep ROW, clear and grub
  - Remove existing pavement
  - Grading operations, excavation, and embankment
  - Excavate and prepare subgrade for proposed pavement widening
  - Remove existing culverts, safety end treatments (SETs)
  - Remove existing metal beam guard fence (MBGF), bridge rail
  - Install proposed pavement per plans
  - Install culverts, culvert extensions, SETs
- Install mow strip, MBGF, bridge rail
- Place flex base
- Rework slopes, grade ditches
- Blade windrowed material back across slopes
- Revegetation of unpaved areas
- Achieve site stabilization and remove sediment and erosion control measures

Other: \_\_\_\_\_

Other: \_\_\_\_\_

Other: \_\_\_\_\_

**1.10 POTENTIAL POLLUTANTS AND SOURCES:**

- Sediment laden stormwater from stormwater conveyance over disturbed area
- Fuels, oils, and lubricants from construction vehicles, equipment, and storage
- Solvents, paints, adhesives, etc. from various construction activities
- Transported soils from offsite vehicle tracking
- Construction debris and waste from various construction activities
- Contaminated water from excavation or dewatering pump-out water
- Sanitary waste from onsite restroom facilities
- Trash from various construction activities/receptacles
- Long-term stockpiles of material and waste
- Other: \_\_\_\_\_
- Other: \_\_\_\_\_
- Other: \_\_\_\_\_

**1.11 RECEIVING WATERS:**

Receiving waters must be depicted on the Environmental Layout Sheets in Attachment 1.2 of this SWP3. Include Segment # for receiving waters.

Tributaries	Classified Waterbody

\* Add (\*) for impaired waterbodies with pollutant in ( ).

**1.12 ROLES AND RESPONSIBILITIES: TxDOT**

- Development of plans and specifications
- Perform SWP3 inspections
- Maintain SWP3 records and update to reflect daily operations
- Other: \_\_\_\_\_
- Other: \_\_\_\_\_

**1.13 ROLES AND RESPONSIBILITIES: CONTRACTOR**

- Day To Day Operational Control
- Maintain schedule of major construction activities
- Install, maintain and modify BMPs
- Other: \_\_\_\_\_
- Other: \_\_\_\_\_

**STORMWATER POLLUTION PREVENTION PLAN (SWP3) (Less Than 1 Acre)**

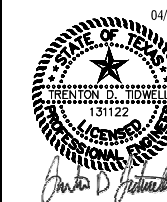

FED. RD. DIV. NO.	PROJECT NO.		SHEET NO.
			046
STATE	STATE DIST.	COUNTY	
TEXAS	FTW	TARRANT	
CONT.	SECT.	JOB	HIGHWAY NO.
1603	03	042	FM 1709

**STORMWATER POLLUTION PREVENTION PLAN (SWP3):**

**2.0 BEST MANAGEMENT PRACTICES (BMPs) AND CONTROLS, INSPECTION, AND MAINTENANCE**

The Contractor shall be the responsible party for implementing the BMPs described herein and for complying with the SWP3 for control of erosion and sedimentation during day-to-day operations. The Contractor shall implement changes to this SWP3 approved by TxDOT within the times specified in this SWP3 or the CGP.

**2.1 EROSION CONTROL AND SOIL STABILIZATION BMPs:**

**T / P**

- Protection of Existing Vegetation
- Vegetated Buffer Zones
- Soil Retention Blankets
- Geotextiles
- Mulching/ Hydromulching
- Soil Surface Treatments
- Temporary Seeding
- Permanent Planting, Sodding or Seeding
- Biodegradable Erosion Control Logs
- Rock Filter Dams/ Rock Check Dams
- Vertical Tracking
- Interceptor Swale
- Riprap
- Diversion Dike
- Temporary Pipe Slope Drain
- Embankment for Erosion Control
- Paved Flumes
- Other: \_\_\_\_\_
- Other: \_\_\_\_\_
- Other: \_\_\_\_\_
- Other: \_\_\_\_\_

**2.2 SEDIMENT CONTROL BMPs:**

**T / P**

- Biodegradable Erosion Control Logs
- Dewatering Controls
- Inlet Protection
- Rock Filter Dams/ Rock Check Dams
- Sandbag Berms
- Sediment Control Fence
- Stabilized Construction Exit
- Floating Turbidity Barrier
- Vegetated Buffer Zones
- Vegetated Filter Strips
- Other: \_\_\_\_\_
- Other: \_\_\_\_\_
- Other: \_\_\_\_\_
- Other: \_\_\_\_\_

Refer to the Environmental Layout Sheets/ SWP3 Layout Sheets located in Attachment 1.2 of this SWP3

**2.3 PERMANENT CONTROLS:**

(Coordinate post-construction BMPs with appropriate TxDOT maintenance sections.)

BMPs To Be Left In Place Post Construction:

Type	Stationing	
	From	To

Refer to the Environmental Layout Sheets/ SWP3 Layout Sheets located in Attachment 1.2 of this SWP3

**2.4 OFFSITE VEHICLE TRACKING CONTROLS:**

- Excess dirt/mud on road removed daily
- Haul roads dampened for dust control
- Loaded haul trucks to be covered with tarpaulin
- Stabilized construction exit
- Other: \_\_\_\_\_

Other: \_\_\_\_\_

Other: \_\_\_\_\_

Other: \_\_\_\_\_

\_\_\_\_\_

\_\_\_\_\_

\_\_\_\_\_

\_\_\_\_\_

\_\_\_\_\_

\_\_\_\_\_

\_\_\_\_\_

**2.5 POLLUTION PREVENTION MEASURES:**

- Chemical Management
- Concrete and Materials Waste Management
- Debris and Trash Management
- Dust Control
- Sanitary Facilities
- Other: \_\_\_\_\_

Other: \_\_\_\_\_

Other: \_\_\_\_\_

Other: \_\_\_\_\_

\_\_\_\_\_

**2.6 VEGETATED BUFFER ZONES:**

Natural vegetated buffers shall be maintained as feasible to protect adjacent surface waters. If vegetated natural buffer zones are not feasible due to site geometry, the appropriate additional sediment control measures have been incorporated into this SWP3.

Type	Stationing	
	From	To

Refer to the Environmental Layout Sheets/ SWP3 Layout Sheets located in Attachment 1.2 of this SWP3

**2.7 ALLOWABLE NON-STORMWATER DISCHARGES:**

- Fire hydrant flushings
- Irrigation drainage
- Pavement washwater (where spills or leaks have not occurred, and detergents are not used)
- Potable water sources
- Springs
- Uncontaminated groundwater
- Water used to wash vehicles or control dust
- Other allowable non-stormwater discharges as allowed by TPDES GP TXR150000.

**2.8 INSPECTIONS:**

All disturbed areas and erosion and sediment control devices shall be inspected at least once every seven (7) days. Inspections shall be performed by TxDOT as indicated on the Field Inspection and Maintenance Report Form 2118 and retained in Attachment 2.3 of this SWP3 .

**2.9 MAINTENANCE:**

Control measures shall be properly installed according to specifications. If it is determined that a BMP or control measure is not operating effectively, maintenance must be accomplished as soon as possible and before the next anticipated rain event, but in no case later than 7 calendar days after being able to access the site. Maintenance shall be performed by the Contractor as indicated on the Field Inspection and Maintenance Report Form 2118 and retained in Attachment 2.3 of this SWP3.

**STORMWATER POLLUTION PREVENTION PLAN (SWP3) (Less Than 1 Acre)**



FED. RD. DIV. NO.	PROJECT NO.			SHEET NO.
				047
STATE	STATE DIST.	COUNTY		
TEXAS	FTW	TARRANT		
CONT.	SECT.	JOB	HIGHWAY NO.	
1603	03	042	FM 1709	