

SEE SHEET 2 FOR INDEX OF SHEETS
SEE SHEETS 3 THRU 5 FOR LOCATION MAPS

STATE OF TEXAS DEPARTMENT OF TRANSPORTATION

PLANS OF PROPOSED STATE HIGHWAY IMPROVEMENT

FEDERAL AID PROJECT NO. STP 2024(632)HES, ETC.

FOR THE CONSTRUCTION OF HAZARD ELIMINATION AND SAFETY
CONSISTING OF INSTALLING SAFETY LIGHTING

FEDERAL AID PROJECT NO.			
STP 2024(632)HES, etc.			
CONT	SECT	JOB	HIGHWAY
0010	08	060	US 67 etc.
etc.	etc.	etc.	etc.
DIST	COUNTY		SHEET NO.
ATL.	MORRIS, etc.		1

MINOR ARTERIAL
AADT (2022) = 5,037
AADT (2042) = 7,052

FINAL PLANS

LETTING DATE: _____
DATE CONTRACTOR BEGAN WORK: _____
DATE WORK WAS COMPLETED & ACCEPTED: _____
FINAL CONTRACT COST: \$ _____
CONTRACTOR : _____
CONTRACTOR ADDRESS: _____
LIST OF APPROVED FIELD CHANGES: _____

THE CONTRACTOR SHALL MAKE HIS OWN INVESTIGATIONS AND ARRANGEMENTS FOR DELIVERY OF MATERIALS.

REQUIRED SIGNS SHALL BE IN ACCORDANCE WITH THE CURRENT BARRICADE AND CONSTRUCTION OR BC SHEETS AND THE "TEXAS MANUAL ON UNIFORM TRAFFIC CONTROL DEVICES".

MORRIS COUNTY
CSJ 0010-08-060
STP 2024(632)HES
US 67
FROM: 0.5 MI. E. OF US 259
TO: 0.5 MI. W. OF US 259
PROJECT LENGTH = 1.000
INSTALL SAFETY LIGHTING

UPSHUR COUNTY
CSJ 0096-03-078
STP 2B24 (209) HES
US 80
FROM: 0.5 MI. E. OF N. RODEO DR.
TO: 0.5 MI. W. OF N. RODEO DR.
PROJECT LENGTH = 1.000
INSTALL SAFETY LIGHTING

UPSHUR COUNTY
CSJ 0248-05-067
STP 2B24 (209) HES
US 271
FROM: 0.5 MI. N. OF FM 726
TO: 0.5 MI. S. OF FM 726
PROJECT LENGTH = 1.000
INSTALL SAFETY LIGHTING

MORRIS COUNTY
CSJ 0392-01-077
STP 2024(794)VRU
US 259
FROM: 0.5 MI. N. OF FM 144
TO: 0.5 MI. S. OF FM 144
PROJECT LENGTH = 1.000
INSTALL SAFETY LIGHTING

MORRIS COUNTY
CSJ 0392-01-078
STP 2024(794)VRU
US 259
FROM: 0.5 MI. N. OF FM 3421
TO: 0.5 MI. S. OF FM 3421
PROJECT LENGTH = 1.000
INSTALL SAFETY LIGHTING

UPSHUR COUNTY
CSJ 0520-02-065
STP 2024(794)VRU
SH 155
AT FM 2911
PROJECT LENGTH = 1.000
INSTALL SAFETY LIGHTING

THE CONSTRUCTION WORK WAS PERFORMED IN SUBSTANTIAL COMPLIANCE WITH THE CONTRACT.

P. E. _____
DATE



TITUS COUNTY
CSJ 0734-01-045
STP 2024(794)VRU
FM 127
AT FM 2882
PROJECT LENGTH = 1.000
INSTALL SAFETY LIGHTING

UPSHUR COUNTY
CSJ 1385-03-009
STP 2024(632)HES
FM 3358
FROM: 0.5 MI. N. OF FM 726
TO: 0.5 MI. S. OF FM 726
PROJECT LENGTH = 1.000
INSTALL SAFETY LIGHTING

UPSHUR COUNTY
CSJ 1763-01-013
STP 2024(794)VRU
FM 1845
FROM: 0.5 MI. N. OF FM 1844
TO: 0.5 MI. S. OF FM 1844
PROJECT LENGTH = 1.000
INSTALL SAFETY LIGHTING

RECOMMENDED FOR LETTING: 3/1/2024

DocuSigned by:

C0CE0F2E6D324D9...
DIRECTOR OF TRANSPORTATION OPERATIONS

RECOMMENDED FOR LETTING: 3/1/2024

DocuSigned by:

3B337C5031074A4...
DISTRICT DIRECTOR OF TRANSPORTATION
PLANNING AND DEVELOPMENT

APPROVED FOR LETTING: 3/1/2024

DocuSigned by:

DISTRICT ENGINEER
23686C08B28F4A0...

SPECIFICATIONS ADOPTED BY THE TEXAS DEPARTMENT OF TRANSPORTATION, NOVEMBER 1, 2014 AND SPECIFICATION ITEMS LISTED AND DATED AS FOLLOWS, SHALL GOVERN ON THIS PROJECT: REQUIRED CONTRACT PROVISIONS FOR ALL FEDERAL-AID CONSTRUCTION CONTRACTS (FORM FHWA 1273, OCTOBER 23, 2023)

EXCEPTIONS: NONE
EQUATIONS: NONE
RAILROAD CROSSINGS: 794662S RRMP 104.47

DATE: 1/29/2024 10:31:51 AM
FILE: I:\engdot\Traffic\GND\192515_Jamie\JOBS\LIGHTING PROJECTS\Lighting Project May 2024\Title Sheet.dgn

COUNTY MORRIS PROJ. NO. STP 2024(632)HES, etc.
HWY. NO. US 67 LETTING DATE MAY, 2024
DATE ACCEPTED

DATE: 1/29/2024 10:32:57 AM
 FILE: I:\enodot\Traffic\Lighting Projects\Lighting Project_May_2024\Title Sheet.dgn

INDEX OF SHEETS

<u>SHEET</u>	<u>DESCRIPTION</u>
<u>GENERAL</u>	
1	TITLE SHEET
2	INDEX OF SHEETS
3-5	LOCATION MAP
6,6A-6E	GENERAL NOTES
7-7A	ESTIMATE AND QUANTITY
8	PROJECT SUMMARY
9-13	SUMMARY OF SMALL SIGNS
<u>TRAFFIC CONTROL PLAN AND STANDARDS</u>	
# 14-25	BC (1)-21 THRU BC (12)-21
# 26-29	TCP (1-1)-18 THRU TCP (1-4)-18
# 30	TCP (2-1)-18
# 31	TCP (3-4)-13
# 32	WZ (RS)-22
# 33-34	WZ (BTS-1)-13 THRU WZ (BTS-2)-13
<u>TRAFFIC ITEMS</u>	
35	ELECTRICAL SERVICE DATA WITH MODIFIED FOUNDATION AND PAD DETAIL
36	TYPICAL INSTALLATION BACK TO BACK SIGN MOUNT
37	EXISTING CONDITION LAYOUT US 67 AT US 259
38-40	PROPOSED ILLUMINATION LAYOUT US 67 AT US 259
41	PROPOSED SIGN AND PAVEMENT MARKING LAYOUT US 67 AT US 259
42	EXISTING CONDITION LAYOUT US 80 AT RODEO DR.
43	PROPOSED ILLUMINATION LAYOUT US 80 AT RODEO DR.
44	EXISTING CONDITION LAYOUT US 271 AT FM 726
45-47	PROPOSED ILLUMINATION LAYOUT US 271 AT FM 726
48	PROPOSED SIGN AND PAVEMENT MARKING LAYOUT US 271 AT FM 726
49	EXISTING CONDITION LAYOUT US 259 AT FM 144
50-53	PROPOSED ILLUMINATION LAYOUT US 259 AT FM 144
54	PROPOSED SIGN AND PAVEMENT MARKING LAYOUT US 259 AT FM 144
55	EXISTING CONDITION LAYOUT US 259 AT FM 3421
56-58	PROPOSED ILLUMINATION LAYOUT US 259 AT FM 3421
59	PROPOSED SIGN AND PAVEMENT MARKING LAYOUT US 259 AT FM 3421
60-61	PROPOSED ILLUMINATION LAYOUT SH 155 AT FM 2911
62-63	PROPOSED ILLUMINATION LAYOUT FM 127 AT FM 2882
64	EXISTING CONDITION LAYOUT FM 3358 AT FM 726
65-66	PROPOSED ILLUMINATION LAYOUT FM 3358 AT FM 726
67	PROPOSED SIGN AND PAVEMENT MARKING LAYOUT FM 3358 AT FM 726
68	EXISTING CONDITION LAYOUT FM 1845 AT FM 1844
69-70	PROPOSED ILLUMINATION LAYOUT FM 1845 AT FM 1844
71	PROPOSED SIGN AND PAVEMENT MARKING LAYOUT FM 1845 AT FM 1844

<u>SHEET</u>	<u>DESCRIPTION</u>
<u>TRAFFIC ITEMS CONTINUED</u>	
# 72	TSR (3)-13
# 73	TSR (4)-13
# 74	PM (1)-22
# 75	PM (3)-22
# 76	RS (5)-23
# 77	SMD (GEN)-08
# 78-80	SMD (SLIP-1)-08 THRU SMD (SLIP-3)-08
# 81	SMD (TWT)-08
# 82-88	ED (1)-14 THRU ED (7)-14
# 89-90	RID (1)-20 AND RID (2)-20
# 91-94	RIP (1)-19 THRU RIP (4)-19
<u>RAILROAD</u>	
95	RAILROAD SCOPE OF WORK PROJECT SPECIFIC DETAILS
96-97	RAILROAD REQUIREMENTS FOR NON-BRIDGE CONSTRUCTION PROJECTS
<u>ENVIRONMENTAL</u>	
98	ENVIRONMENTAL PERMITS, ISSUES AND COMITMENTS

THE STANDARD SHEETS SPECIFICALLY IDENTIFIED WITH A POUND "*" HAVE BEEN ISSUED BY ME, OR UNDER MY RESPONSIBLE SUPERVISION AS BEING APPLICABLE TO THIS PROJECT.

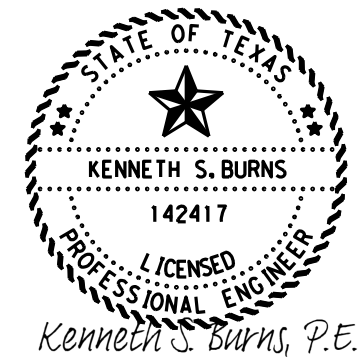

1/30/2024

INDEX OF SHEETS

© 2024			
FHWA TEXAS DIVISION	PROJECT NO.	SHEET NO.	
STP 2024(632)HES, etc.		2	
STATE	DISTRICT	COUNTY	
TEXAS	ATL	MORRIS	
CONTROL	SECTION	JOB	HIGHWAY NO.
0010	08	060	US 67
etc. etc. etc. etc.			

FILE: T:\Engdata\Traffic\DCM\192515 Jamie\JOBS\LIGHTING PROJECTS\Lighting Project May 2024\Location Maps.dgn
 DATE: 1/29/2024 2:58:03 PM

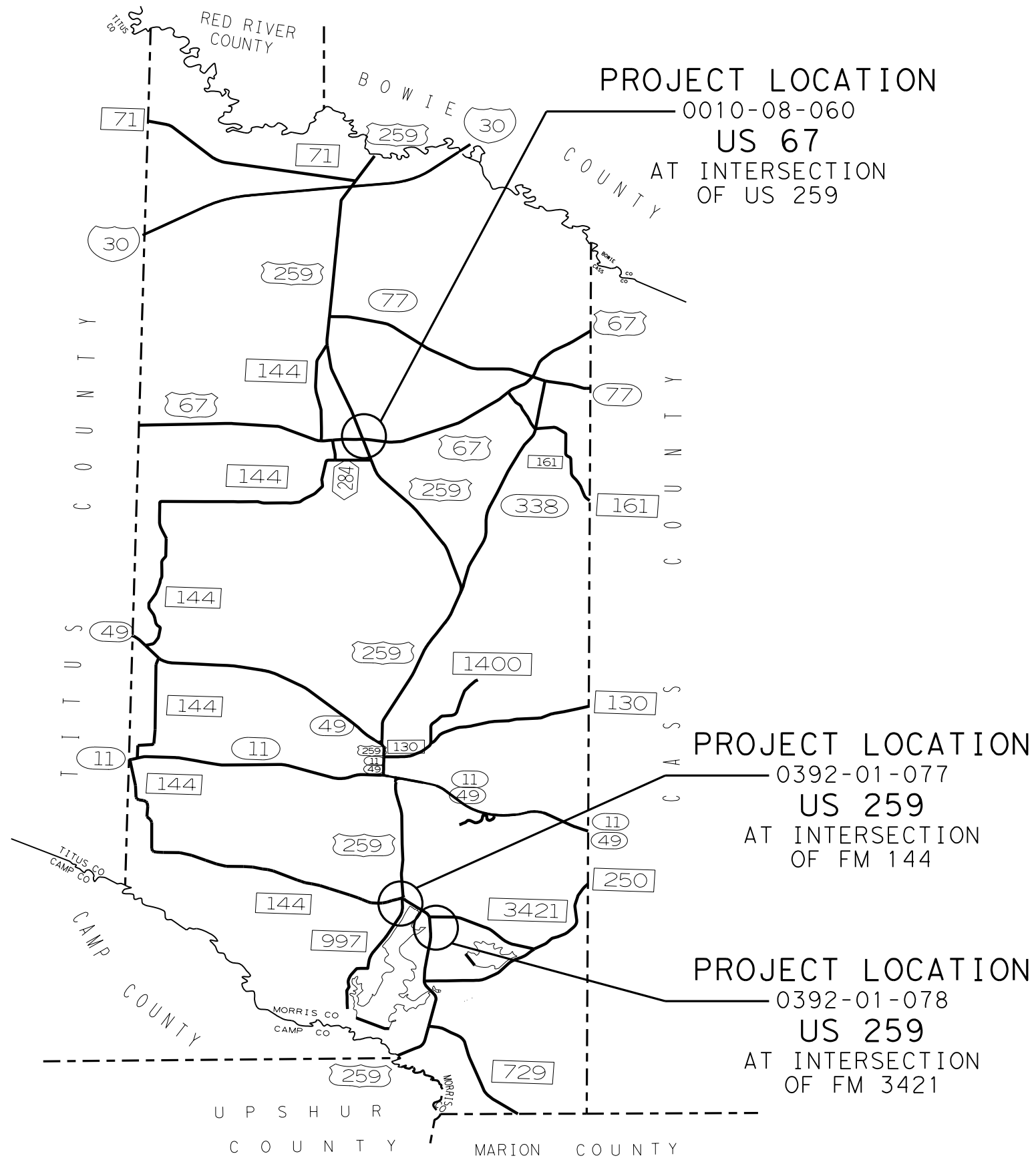

LOCATION MAP

© 2024 Texas Department of Transportation
 SHEET 1 OF 3

FHWA TEXAS DIVISION		CONSTRUCTION PROJECT NO.		SHEET NO.
				3
STATE	DISTRICT	COUNTY		
TEXAS	ATL	MORRIS		
CONTROL	SECTION	JOB	HIGHWAY NO.	
0010	08	060	US 67	

MORRIS COUNTY

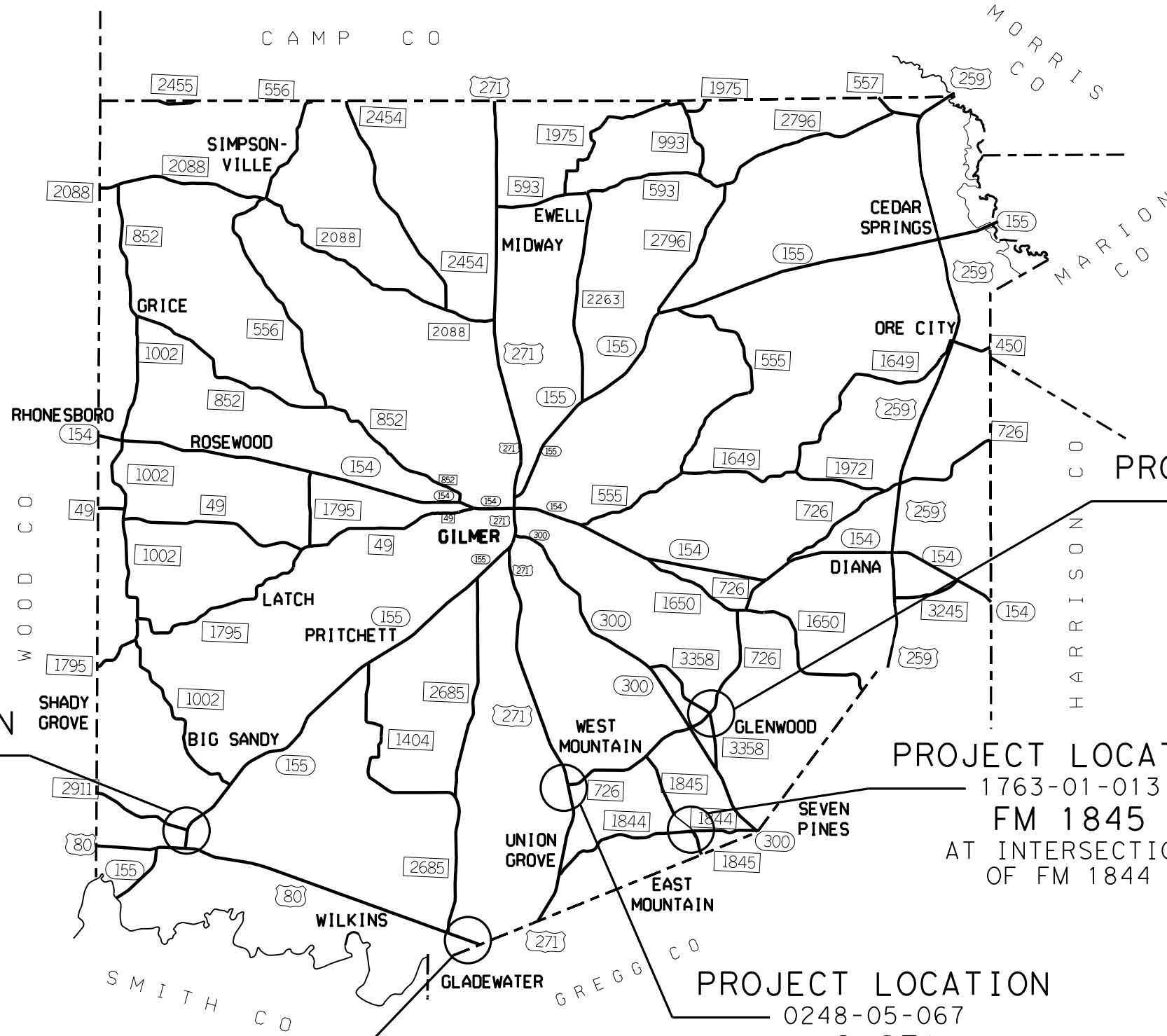

PROJECT LOCATION
1385-03-009
FM 3358
AT INTERSECTION
OF FM 726

PROJECT LOCATION
0520-02-065
SH 155
AT INTERSECTION
OF FM 2911

PROJECT LOCATION
1763-01-013
FM 1845
AT INTERSECTION
OF FM 1844

PROJECT LOCATION
0096-03-078
US 80
AT INTERSECTION
OF RODEO DR.

PROJECT LOCATION
0248-05-067
US 271
AT INTERSECTION
OF FM 726

UPSHUR COUNTY

LOCATION MAP

© 2024 Texas Department of Transportation
SHEET 3 OF 3

FHWA TEXAS DIVISION	CONSTRUCTION PROJECT NO.		SHEET NO.
			5
STATE	DISTRICT	COUNTY	
TEXAS	ATL	MORRIS	
CONTROL	SECTION	JOB	HIGHWAY NO.
0010	08	060	US 67

NOT TO SCALE

Control: 0010-08-060
County: Morris, etc.
Highway: US 67 etc.

Sheet:

Control: 0010-08-060
County: Morris, etc.
Highway: US 67 etc.

Sheet: 6

GENERAL NOTES:

General Requirements and Covenants:

Contractor questions on this project are to be addressed to the following individuals:

Christina Trowler P.E. – Director of Transportation Operations
Christina.Trowler@Txdot.gov
Kenneth Burns P.E. – Transportation Engineer
Kenneth.Burns@Txdot.gov

Questions may be submitted via the Letting Pre-Bid Q&A web page. This webpage can be accessed from the Notice to Contractors dashboard located at the following Address:

[https://tableau.txdot.gov/views/ProjectInformationDashboard/NoticetoContractors?%](https://tableau.txdot.gov/views/ProjectInformationDashboard/NoticetoContractors?%20)

All contractor questions will be reviewed by the Engineer. All questions and any corresponding responses that are generated will be posted through the same Letting Pre-Bid Q&A web page.

The Letting Pre-Bid Q&A web page for each project can be accessed by using the dashboard to navigate to the project you are interested in by scrolling or filtering the dashboard using the controls on the left. Hover over the blue hyperlink for the project you want to view the Q&A for and click on the link in the window that pops up.

Each contract awarded by the Department stands on its own and as such, is separate from other contracts. A Contractor awarded multiple contracts must be capable and sufficiently staffed to concurrently process any or all contracts.

Notify the Engineer or their representative by 8:15 a.m. on any day when working in the District.

Clean up and remove all loose material resulting from contract operations each day before work is suspended for that day.

Repair all pavement damaged by the Contractor's forces during construction. Such repair is to be considered incidental to the various bid items in the project and must be approved by engineer.

Plans are required for this project.

ITEM 5 – Control of the Work:

Contact all utility companies for the exact location of underground utilities before boring, trenching or any other work that might interfere with or damage existing utilities.

Repair any damage caused to utilities by Contractor operations at own expense and restore service in a timely manner.

Work on any project will not be accepted until all components have been shown to be fully operational.

At the intersection of US 80 at Rodeo Dr. none of the proposed work will be on the Union Pacific Railroad right-of-way. The Contractor will be working less than 50' feet from the Railroad right-of-way line when they are working on installing the luminaires on the south side of the intersection at US 80 at Rodeo Dr. Railroad Protective Flagging will be required while the Contractor is working on installing the luminaires at these locations only near the Union Pacific Track. Because the Contractor will be working in close proximity to the Union Pacific right-of-way line, the Contractor will need to meet all necessary railroad insurance requirements with the Union Pacific Railroad. Reference Railroad Scope of Work Project Specific Details DOT 794662S in the plan set.

ITEM 6 - Control of Material:

To comply with the latest provisions of Build America, Buy America Act (BABA Act) of the Bipartisan Infrastructure Law, the contractor must submit an original of the TxDOT Construction Material Buy America Certification Form for all items classified as construction materials. This form is not required for materials classified as a manufactured product.

Refer to the Buy America Material Classification Sheet for clarification on material categorization.

The Buy America Material Classification Sheet is located at the below link.

<https://www.txdot.gov/business/resources/materials/buy-america-material-classification-sheet.html> for clarification on material categorization.

When requesting payments for material on hand, contractor's material storage facility will be within the Atlanta District.

Pre-qualified products can be found at <http://www.txdot.gov/business/resources/producer-list.html>

Control: 0010-08-060
County: Morris, etc.
Highway: US 67 etc.

Sheet:

Control: 0010-08-060
County: Morris, etc.
Highway: US 67 etc.

Sheet: 6A

ITEM 7 – Legal Relations and Responsibilities:

This project is considered a maintenance activity and is exempt from the Construction General Permit (CGP) coverage.

No significant traffic generator events.

ITEM 8 – Prosecution and Progress:

Working days will be charged in accordance with Section 8.3.1.4, “Standard Workweek”

Refer to SP 008---010 (180 days) for additional information regarding beginning of working day charges. The lead time will be to allow for fabrication of roadway illumination poles.

Work on the roadway will not begin until thirty (30) minutes after sunrise and will end on the roadway by thirty (30) minutes before sunset or as directed by the Engineer.

Provide progress schedules meeting the requirements of Section 8.5.2 in 2014 Standard Specifications for Construction and Maintenance of Highways, Streets, and Bridges.

ITEM 9 – Measurement and Payment:

For all pay items, a daily email will be sent to the inspector with the item number, quantity, and location description.

ITEM 416 – Drilled Shaft Foundations:

Foundation locations will be staked by the Contractor. The Engineer will be given a minimum of 3 days advance notice to ensure placement is in the proposed design location. Chamfer or tool exposed edges or joints of concrete as directed.

ITEM 421 – Hydraulic Cement Concrete:

The Department will furnish and maintain concrete compressive strength testing equipment.

ITEM 432 - Riprap:

Provide ½” expansion joint material with an area equal to the area of contact between the two concrete surfaces. The joint material will be visually inspected for approval.

ITEM 502 – Barricades, Signs, and Traffic Handling:

The Contractor Force Account “Safety Contingency” that has been established for this project is intended to be utilized for work zone enhancements, to improve the effectiveness of the Traffic Control Plan, that could not be foreseen in the project planning and design stage. These enhancements will be mutually agreed upon by the Engineer and the Contractor’s Responsible Person based on weekly or more frequent traffic management reviews on the project. The Engineer may choose to use existing bid items if it does not slow the implementation of enhancement.

Install temporary rumble strips in accordance with WZ(RS) wherever short duration or short-term stationary lane closures are in place and workers are present.

The Contractor's responsible person (CRP) will be responsible for ensuring that the signs and traffic control devices are in place and functioning properly.

The CRP will inspect and ensure any deficiencies are corrected each and every day throughout the duration of this contract. Notify the Engineer in writing of the name, address, and telephone number of this employee or these employees.

Maintenance of driveways and intersections will not be paid for directly but is subsidiary to the pertinent bid items.

Restrict the movement of equipment across traffic lanes to an absolute minimum.

Use strobe lights or rotating beacons on all motorized equipment, operating on or adjacent to the road surface.

There may be ongoing contracts on several of the roadways included in this contract. Coordinate work with these projects and consult with the Engineer when developing sequence of work.

The Traffic Control Plan for this contract consists of the installation and maintenance of warning signs and or other traffic control devices shown in the plans, specification data which may be included in the general notes, applicable provisions of the Texas Manual on Uniform Traffic Control Devices (TMUTCD), traffic control plan sheets included in the plans, standard BC sheets and Item 502 of the standard specifications.

Control: 0010-08-060
County: Morris, etc.
Highway: US 67 etc.

Sheet:

The traffic control plan sheets when shown in the plans for handling traffic through the work area. The signing arrangement and spacing shown may be varied as necessary to fit field conditions; however, any proposed changes in the traffic control plan must be approved by the Engineer prior to implementation

A Type B flashing arrow panel will be required on this project when a lane of traffic is to be closed for any duration of time.
Anytime equipment encroaches into a travel lane as shown on WZ BTS and TCP standards shown in this project, the Contractor will be required to have at least one shadow vehicle with a truck mounted attenuator as directed.

Notify inspector prior to any planned lane closures. Lane closures must be entered in the HCR (Highway Condition Report) 48 hours prior to beginning work.

All flaggers will be properly attired, orange or fluorescent type III vests and white hard hats are required. Proper flagging procedures must be demonstrated by all workers in accordance with the "Texas Manual on Uniform Traffic Control Device." A list of all qualified flaggers will be furnished by the Contractor before beginning work. This list will be updated as flaggers become qualified.

Provide flaggers at the ends of work areas and at all other points of conflict with roadway machinery and roadway traffic when and as directed.

No equipment will be left within 30 feet of the travel way. Equipment and/or obstructions within 30 feet of the travel way will be removed or clearly marked by warning lights and barricades, as directed.

Place construction fencing a minimum of 4 feet high around bore pits open over night for pedestrian safety. Use appropriate post to install fencing around open pits, do not use equipment as part of post or fencing system.

In urban areas and high-speed areas the contractor will be required to set up full lane closures when working at intersections as directed by the Engineer.

With reference to WZ (BTS-1), typical hanging signal installations, the Contractor may be required to close a traffic lane(s) as directed.

Restrict the movement of equipment across traffic lanes to an absolute minimum.

All warning signs will be (48 inches x 48 inches) black on orange, factory made and in satisfactory condition.

Install temporary rumble strips in accordance with WZ(RS) whenever short duration stationary lane closures are in place and workers are present. A minimum of two rumble strips shall be used.

Control: 0010-08-060
County: Morris, etc.
Highway: US 67 etc.

Sheet: 6B

Place construction fencing a minimum of 4 feet high around bore pits open over night for pedestrian safety. Use appropriate post to install fencing around open pits, do not use equipment as part of post or fencing system.

The existing number of lanes open to traffic will not be reduced except that lane closures will be required on high speed roadways for all short term/short duration work that requires a vehicle to be in the roadway or as directed.

All locations will require WZ (BTS-2) setup for project signs. Roll up signs will be used daily when on site.

ITEM 506 – Temporary Erosion, Sedimentation, and Environmental

Controls:

Place erosion or pollution control measures deemed necessary by the Engineer. Work performed for which there is no applicable pay items in the contract will be reimbursed in accordance with Article 9.7, "Payment for Extra Work and Force Account Method".

It is the intent of this contract that no disturbance of vegetation occurs as a result of roadway operations. In the event vegetation is disturbed, place erosion or pollution control measures deemed necessary by the Engineer. Work performed for which there are no applicable pay items in the contract will be reimbursed in accordance with Article 9.7, "Payment for Extra Work and Force Account Method".

ITEM 610 – Roadway Illumination Assemblies:

Luminaire foundations will require an apron as shown on standard RID(FND) or as directed.

There will not be any stockpiles on the job site from illumination installations. Remove any additional soil, rock, and concrete from job site the same day that they are produced.

ITEM 618 – Conduit:

When the specifications for electrical items require UL listed products, it will be understood to mean UL listed or Any Nationally Recognized Testing Lab (NRTL).

Aluminum conduit is acceptable for this project where rigid metal conduit is used above ground. Aluminum conduit specification will be submitted to the Engineer for approval. The aluminum conduit will be new and unused and UL-Listed. Notify the Engineer that aluminum conduit will be used on this project. Aluminum conduit will be installed, measured, and paid for under item 618.

The locations of conduit as shown are for diagrammatic purposes only and may be varied to meet local conditions, subject to approval.

Control: 0010-08-060
County: Morris, etc.
Highway: US 67 etc.

Sheet:

All conduit placed under existing pavement will be bored as directed. Cutting, trenching or jacking across roadways or driveways will not be permitted without approval.

Install a 3-inch warning tape on trenched conduit runs during backfill operations. The tape will be red polyethylene marked "CAUTION-BURIED ELECTRIC LINE". Place the tape 12 inches above the conduit. Measurement and payment are subsidiary to Item 618, "Conduit".

When backfilling bore pits, ensure the conduit does not become damaged. Place select backfill in three equal lifts to the bottom of the conduit or place sand to a point 2 inches above the conduit. Compact the backfill to obtain a density equal to the existing, adjacent soil. Prevent backfill material from entering the conduit.

Excavate bore pits no closer than 2 feet from the edge of pavement or base.

The vertical and horizontal tolerances of bored conduits are not to exceed 18 inches as measured from the target point.

Ensure that all PVC conduit and fittings will be schedule 40.

Bell end fittings will be used at the ends of all non-metallic conduits. (e.g., metal junction box).

Where PVC, duct cable, and HDPE conduit 1" and larger is allowed and installed as per TxDOT standards, provide a PVC elbow in place of the galvanized rigid metal elbow required by the Electrical Detail Standards. Ensure the PVC elbow is of the same schedule rating as the conduit to which is connected. Ensure only a flat, high tensile strength polyester fiber pull tape is used for pulling conductor through the PVC conduit system.

ITEM 620 – Electrical Conductors:

Grounding conductors sharing the same conduit, junction box, ground box or structure will be bonded together at accessible points in accordance with the current edition of the National Electrical Code.

Complete splices using approved splicing methods and insulate with an approved thermosetting compound, heavy duty heat shrinkable tubing with sealant, or heat shrinkable tape with sealant suitable for outdoor use.

Electrical certification for this project will be as per Item 7 of the current Texas Standard Specifications and any special provisions to Item 7.

For both transformer and shoe-base type illumination poles, provide double-pole breakaway fuse holder as shown on the Texas Department of Transportation (TXDOT) materials producers list.

Control: 0010-08-060
County: Morris, etc.
Highway: US 67 etc.

Sheet: 6C

Category is "Roadway Illumination and Electrical Supplies". Fuse holder is shown on list under Items 610 and 620. Provide 10-amp time delay fuses.

When the specifications for electrical items require UL listed products, it will be understood to mean UL listed or Any Nationally Recognized Testing Lab (NRTL).

ITEM 624 – Ground Boxes:

Locations of ground boxes are approximate. Final locations will be as approved.

Ground boxes will require an apron as directed by the Engineer as shown on standard ED (4).

When ground boxes are placed in existing concrete sidewalk, saw cut sidewalk and repair any damage to the surrounding concrete. This work will not be paid for separately but considered subsidiary to this item.

ITEM 628 – Electrical Services:

The power company will connect the power to the service lines at the weather heads and will furnish and install meters.

Make arrangements with the appropriate electric power company to provide electric service. Notify the electric power company at least 3 weeks in advance of the need for the service connection. Time suspension will not be issued to Contractor for awaiting utility service connection.

Make all arrangements for electrical service and comply with local standards and practices for proper installation.

Foundations for the all of the proposed overhead electrical services on this project will be 30-A. Foundations will not be paid for separately but will be subsidiary to Item 628. Foundation depth for these services will be six feet.

Concrete rip rap service pad will be constructed on all proposed electrical services on this project. Concrete rip rap for the service pads will be paid for under Item 432.

Construct the proposed electrical service as shown on Electrical Detail (ED) Sheets, as shown in the electrical service summary and in accordance with Item 628, "Electrical Services". Make all arrangements for electrical service and comply with local standards and practices for proper installation.

Refer to Electrical Service Data with Modified Foundation and Pad Detail sheets for list of electrical services and power companies for each intersection.

Control: 0010-08-060
County: Morris, etc.
Highway: US 67 etc.

Sheet:

ITEM 636 - Signs:

Ensure the location and details of the fabrication, assembly and erection of the aluminum signs are in accordance with the details shown on the plans.

Ensure the Contractor's working drawings, for extruded aluminum signs, conform to the details shown on the plans.

Transport signs in such a manner as to not damage the high intensity reflective sheeting. Carry signs in a standing position within a divider rack assembly.

ITEM 644 – Small Roadside Sign Assemblies:

Type A signs will be made of flat aluminum.

Existing sign assemblies will be removed after the proposed sign is installed. Contractor will leave existing sign in place while proposed sign goes up. The existing sign will be removed immediately after the proposed sign is installed.

For this project, the standard triangular slip base two bolt casting will be used. This casting must be furnished from an approved manufacturer.

Erect the proposed signs an appropriate distance from adjacent signs in accordance with the Texas MUTCD, as directed and as shown on the plans.

Verify the elevation difference between the edge of the travel lane and bottom of the sign.

Do not remove existing sign assemblies until signs are ready to be installed on new mounts.

Sign assemblies associated with warning signs or stop or yield signs will require Omni - Directional Post Wrap. Retroreflective sheeting wrapped around a warning sign is yellow. Stop or Yield signs will require red sheeting. Retroreflective sheeting wrapped around a sign has a height on the post of at least 12 inches. The bottom of the retroreflective sheeting will be placed two feet below the bottom of the sign. The Engineer will approve the retroreflective sheeting wrap prior to any installation. This work will not be paid for separately; but will be subsidiary to this Item.

Flat aluminum signs removed on the project will remain property of the State. The signs are to be delivered to the nearest Atlanta District Maintenance office yard, coordinate delivery with the Engineer. Mounting hardware and supports will remain property of the contractor to dispose of in accordance with federal, state and local regulations. This work will not be paid for separately but will be subsidiary to this Item.

Control: 0010-08-060
County: Morris, etc.
Highway: US 67 etc.

Sheet: 6D

ITEM 668 – Prefabricated Pavement Marking:

Prefabricated Pavement Markings will be placed at locations as directed.

ITEM 677 – Eliminating Existing Pavement Markings and Markers:

For this project the only removal of pavement markings required will be at the intersection of FM 726 and FM 3358 where 4" pavement markings will need to be removed back to the proposed new stop bars on FM 3358. Due to this location being a seal coat surface grinding method, and water blasting will damage the roadway surface. Removal at this location will be accomplished by covering the markings with black pre-fab Type C pavement markings. This work will be paid for under this item.

ITEM 680 – Highway Traffic Signals:

The existing span wire is not to be removed until the proposed luminaires are functioning, and the proposed signs are in place. Remove the existing strain pole foundations 2 ft. below grade in accordance with this Item. All removal items for the signals will become the property of the Contractor upon removal.

ITEM 6001 – Portable Changeable Message Sign:

Portable Changeable Message signs will be used on this contract. For this contract the Portable Changeable Message Signs will be used at the intersection of FM 3358 and FM 726 as this intersection will be turned into an All-Way Stop Condition. Portable Changeable Message Signs will be set out on all approaches to the intersection 5 days prior to conversion for the stop condition. Portable Changeable Message Signs will remain in place for 7 days after conversion to an All-Way Stop Condition. Messages and placement will be as directed by the Engineer. Signs will be paid for by the day after installed and fully operational.

Item 6056 – Preformed In-Lane (Transverse)/Centerline Rumble Strips:

Supply all equipment and materials necessary for placement of In-Lane or Transverse Rumble Strips.

Do not place pavement markings until rumble strips are accepted by written acceptance.

Control: 0010-08-060
County: Morris, etc.
Highway: US 67 etc.

Sheet: 6E

ITEM 6185–Truck Mounted Attenuator (TMA) and Trailer Attenuator (TA):

The shadow vehicle with truck mounted attenuator (TMA) will not be optional but will be required as shown on the appropriate traffic control plan sheets.

A total of one (1) shadow vehicle with TMA will be required for work. The contractor will be responsible for determining if one or more of these operations will be ongoing at the same time to determine the total number of TMA's needed for the project.



Estimate & Quantity Sheet

CONTROLLING PROJECT ID 0010-08-060

DISTRICT Atlanta

COUNTY Morris, Titus, Upshur

HIGHWAY FM 127, FM 1845, FM 3358, SH 155, US 259, US 271, US 67, US 80

CONTROL SECTION JOB				0010-08-060		0096-03-078		0248-05-067		0392-01-077		0392-01-078		0520-02-065	
PROJECT ID				A00192735		A00192684		A00192731		A00177388		A00177392		A00184146	
COUNTY				Morris		Upshur		Upshur		Morris		Morris		Upshur	
HIGHWAY				US 67		US 80		US 271		US 259		US 259		SH 155	
ALT	BID CODE	DESCRIPTION	UNIT	EST.	FINAL	EST.	FINAL	EST.	FINAL	EST.	FINAL	EST.	FINAL	EST.	FINAL
	416-6029	DRILL SHAFT (RDWY ILL POLE) (30 IN)	LF	60.000		20.000		50.000		90.000		70.000		30.000	
	432-6006	RIPRAP (CONC)(CL B)	CY	3.000		2.000		3.000		4.000		3.000		2.000	
	500-6001	MOBILIZATION	LS	1.000											
	502-6001	BARRICADES, SIGNS AND TRAFFIC HANDLING	MO	10.000											
	610-6216	IN RD IL (TY SA) 40T-10 (250W EQ) LED	EA									7.000			
	610-6288	IN RD IL (TY SA) 50T-10 (400W EQ) LED	EA	6.000		2.000		5.000		9.000				3.000	
	618-6023	CONDT (PVC) (SCH 40) (2")	LF	562.000		128.000		658.000		1,122.000		847.000		460.000	
	618-6024	CONDT (PVC) (SCH 40) (2") (BORE)	LF	682.000		180.000		409.000		864.000		408.000		174.000	
	620-6009	ELEC CONDR (NO.6) BARE	LF	1,294.000		328.000		1,117.000		2,056.000		1,310.000		684.000	
	620-6010	ELEC CONDR (NO.6) INSULATED	LF	2,644.000		656.000		2,284.000		4,232.000		2,678.000		1,368.000	
	624-6002	GROUND BOX TY A (122311)W/APRON	EA	3.000		3.000		4.000		4.000		3.000		6.000	
	624-6010	GROUND BOX TY D (162922)W/APRON	EA	1.000											
	628-6004	ELC SRV TY A 120/240 060(NS)AL(E)SP(O)	EA	1.000		1.000		1.000		1.000		1.000		1.000	
	644-6027	IN SM RD SN SUP&AM TYS80(1)SA(P)	EA					1.000		1.000		1.000			
	644-6030	IN SM RD SN SUP&AM TYS80(1)SA(T)	EA					1.000							
	644-6061	IN SM RD SN SUP&AM TYTWT(1)WS(T)	EA					1.000		2.000		2.000			
	644-6076	REMOVE SM RD SN SUP&AM	EA					2.000		2.000		2.000			
	668-6076	PREFAB PAV MRK TY C (W) (24") (SLD)	LF	153.000				32.000		34.000		25.000			
	668-6077	PREFAB PAV MRK TY C (W) (ARROW)	EA	5.000				6.000							
	668-6085	PREFAB PAV MRK TY C (W) (WORD)	EA	27.000				14.000							
	668-6092	PREFAB PAV MRK TY C (W) (36")(YLD TRI)	EA	26.000											
	677-6001	ELIM EXT PAV MRK & MRKS (4")	LF												
	680-6004	REMOVING TRAFFIC SIGNALS	EA	1.000		1.000		1.000		1.000		1.000			
	6001-6001	PORTABLE CHANGEABLE MESSAGE SIGN	DAY												
	6056-6001	PREFORMED IN-LANE(TRANS) RUMBLE STRIP	LF	320.000											
	6185-6002	TMA (STATIONARY)	DAY	15.000		15.000		15.000		15.000		15.000		15.000	
	01	STATE FORCE ACCOUNT WORK (NON-PARTICIPATING)	LS					1.000		1.000		1.000			
	12	RAILROAD FLAGGING: RAILROAD FORCE ACCOUNT WORK (PARTICIPATING)	LS			1.000									
	18	SAFETY CONTINGENCY: CONTRACTOR FORCE ACCOUNT WORK (PARTICIPATING)	LS	1.000											
		EROSION CONTROL MAINTENANCE: CONTRACTOR FORCE ACCOUNT WORK (PART)	LS	1.000											



Estimate & Quantity Sheet

CONTROLLING PROJECT ID 0010-08-060

DISTRICT Atlanta

COUNTY Morris, Titus, Upshur

HIGHWAY FM 127, FM 1845, FM 3358, SH 155, US 259, US 271, US 67, US 80

CONTROL SECTION JOB				0734-01-045		1385-03-009		1763-01-013		TOTAL EST.	TOTAL FINAL
PROJECT ID				A00184143		A00177205		A00177203			
COUNTY				Titus		Upshur		Upshur			
HIGHWAY				FM 127		FM 3358		FM 1845			
ALT	BID CODE	DESCRIPTION	UNIT	EST.	FINAL	EST.	FINAL	EST.	FINAL		
	416-6029	DRILL SHAFT (RDWY ILL POLE) (30 IN)	LF	30.000		40.000		40.000		430.000	
	432-6006	RIPRAP (CONC)(CL B)	CY	2.000		2.000		2.000		23.000	
	500-6001	MOBILIZATION	LS							1.000	
	502-6001	BARRICADES, SIGNS AND TRAFFIC HANDLING	MO							10.000	
	610-6216	IN RD IL (TY SA) 40T-10 (250W EQ) LED	EA					4.000		11.000	
	610-6288	IN RD IL (TY SA) 50T-10 (400W EQ) LED	EA	3.000		4.000				32.000	
	618-6023	CONDT (PVC) (SCH 40) (2")	LF	311.000		243.000		295.000		4,626.000	
	618-6024	CONDT (PVC) (SCH 40) (2") (BORE)	LF	157.000		385.000		189.000		3,448.000	
	620-6009	ELEC CONDR (NO.6) BARE	LF	498.000		678.000		534.000		8,499.000	
	620-6010	ELEC CONDR (NO.6) INSULATED	LF	996.000		1,356.000		1,068.000		17,282.000	
	624-6002	GROUND BOX TY A (122311)W/APRON	EA	3.000		5.000		4.000		35.000	
	624-6010	GROUND BOX TY D (162922)W/APRON	EA							1.000	
	628-6004	ELC SRV TY A 120/240 060(NS)AL(E)SP(O)	EA	1.000		1.000		1.000		9.000	
	644-6027	IN SM RD SN SUP&AM TYS80(1)SA(P)	EA			8.000		4.000		15.000	
	644-6030	IN SM RD SN SUP&AM TYS80(1)SA(T)	EA							1.000	
	644-6061	IN SM RD SN SUP&AM TYTWT(1)WS(T)	EA			6.000		8.000		19.000	
	644-6076	REMOVE SM RD SN SUP&AM	EA			8.000		8.000		22.000	
	668-6076	PREFAB PAV MRK TY C (W) (24") (SLD)	LF			84.000		62.000		390.000	
	668-6077	PREFAB PAV MRK TY C (W) (ARROW)	EA							11.000	
	668-6085	PREFAB PAV MRK TY C (W) (WORD)	EA					8.000		49.000	
	668-6092	PREFAB PAV MRK TY C (W) (36")(YLD TRI)	EA							26.000	
	677-6001	ELIM EXT PAV MRK & MRKS (4")	LF			82.000				82.000	
	680-6004	REMOVING TRAFFIC SIGNALS	EA			1.000		1.000		7.000	
	6001-6001	PORTABLE CHANGEABLE MESSAGE SIGN	DAY			48.000				48.000	
	6056-6001	PREFORMED IN-LANE(TRANS) RUMBLE STRIP	LF					320.000		640.000	
	6185-6002	TMA (STATIONARY)	DAY	15.000		15.000		15.000		135.000	
	01	STATE FORCE ACCOUNT WORK (NON-PARTICIPATING)	LS			1.000		1.000		5.000	
	12	RAILROAD FLAGGING: RAILROAD FORCE ACCOUNT WORK (PARTICIPATING)	LS							1.000	
	18	SAFETY CONTINGENCY: CONTRACTOR FORCE ACCOUNT WORK (PARTICIPATING)	LS							1.000	
		EROSION CONTROL MAINTENANCE: CONTRACTOR FORCE ACCOUNT WORK (PART)	LS							1.000	

FILE: T:\engdata\Traffic\DGN\192515 Jamie\JOBS\LIGHTING PROJECTS\Lighting Project May 2024\sum.dgn
 DATE: 1/25/2024 2:40:35 PM







ITEM NO.	DESC CODE	DESCRIPTION	UNIT	US 67 AT US 259 0010-08-060	US 80 AT RODEO DR. 0096-03-078	US 271 AT FM 726 0248-05-067	US 259 AT FM 144 0392-01-077	US 259 AT FM 3421 0392-01-078	SH 155 AT FM 2911 0520-02-065	FM 127 AT FM 2882 0734-01-045	FM 3358 AT FM 726 1385-03-009	FM 1845 AT FM 1844 1763-01-013
0416	6029	DRILL SHAFT (RDWY ILL POLE) (30 IN)	LF	60	20	50	90	70	30	30	40	40
0432	6006	RIPRAP (CONC) (CL B)	CY	3	2	3	4	3	2	2	2	2
0610	6216	IN RD IL (TY SA) 40T-10(250W EQ)LED	EA					7				4
0610	6288	IN RD IL (TY SA) 50T-10(400W EQ)LED	EA	6	2	5	9		3	3	4	
0618	6023	CONDT (PVC)(SCH 40)(2")	LF	562	128	658	1122	847	460	311	243	295
0618	6024	CONDT (PVC)(SCH 40)(2")(BORE)	LF	682	180	409	864	408	174	157	385	189
0620	6009	ELEC CONDUCTOR (NO 6) BARE	LF	1294	328	1117	2056	1310	684	498	678	534
0620	6010	ELEC CONDUCTOR (NO 6) INSULATED	LF	2644	656	2284	4232	2678	1368	996	1356	1068
0624	6002	GROUND BOX TY A (122311)W/APRON	EA	3	3	4	4	3	6	3	5	4
0624	6010	GROUND BOX TY D (162922)W/APRON	EA	1								
0628	6004	ELC SRV TY A 120/240 060 (NS)AL(E) SP(O)	EA	1	1	1	1	1	1	1	1	1
0644	6027	IN SM RD SN SUP&AMTY S80(1)SA(P)	EA			1	1	1			8	4
0644	6030	IN SM RD SN SUP&AMTY S80(1)SA(T)	EA			1						
0644	6061	IN SM RD SN SUP&AMTY TWT(1)WS(T)	EA			1	2	2			6	8
0644	6076	REMOVE SM RD SN SUP&AM	EA			2	2	2			8	8
0668	6076	PREFAB PAV MRK TY C (W)(24")(SLD)	LF	153		32	34	25			84	62
0668	6077	PREFAB PAV MRK TY C (W)(ARROW)	EA	5		6						
0668	6085	PREFAB PAV MRK TY C (W)(WORD)	EA	27		14						8
0668	6092	PREFAB PAV MRK TY C (W)(36")(YLD TRI)	EA	26								
0677	6001	ELIM EXT PAV MRK & MRKS (4")	LF								82	
0680	6004	REMOVING TRAFFIC SIGNALS	EA	1	1	1	1	1			1	1
6001	6001	PORTABLE CHANGEABLE MESSAGE SIGNS	DAY								48	
6056	6001	PREFORMED IN-LANE (TRANS) RUMBLE STRIP	LF	320								320
6185	6002	TMA (STATIONARY)	DAY	15	15	15	15	15	15	15	15	15
*		LED RINGS	EA			1	1	1			4	4
*		PROVIDED BY TXDOT; INSTALLED BY TXDOT										

PROJECT SUMMARY

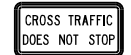
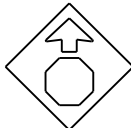

FHWA TEXAS DIVISION		CONSTRUCTION PROJECT NO.		SHEET NO.
				8
STATE	DISTRICT	COUNTY		
TEXAS	ATL	MORRIS		
CONTROL	SECTION	JOB	HIGHWAY NO.	
0010	08	060	US 67	

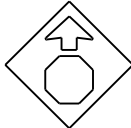
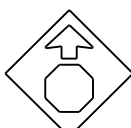
SUMMARY OF SMALL SIGNS

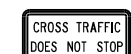
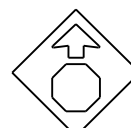
PLAN SHEET NO.	SIGN NO.	SIGN NOMENCLATURE	SIGN	DIMENSIONS	FLAT ALUMINUM (TYPE A)	EXAL ALUMINUM (TYPE G)	SM RD SGN ASSM TY XXXXX (X) XX (X-XXXX)				BRIDGE MOUNT CLEARANCE SIGNS (See Note 2)	
							POST TYPE	POSTS	ANCHOR TYPE	MOUNTING DESIGNATION		
							FRP = Fiberglass TWT = Thin-Wall 10BWG = 10 BWG S80 = Sch 80	1 or 2	UA=Universal Conc UB=Universal Bolt SA=Slipbase-Conc SB=Slipbase-Bolt WS=Wedge Steel WP=Wedge Plastic	PREFABRICATED P = "Plain" T = "T" U = "U"		1EXT or 2EXT = # of Ext BM = Extruded Wind Beam WC = 1.12 #/ft Wing Channel EXAL= Extruded Alum Sign Panels
48	1	R1-1		48"X48"	✓		S80	1	SA	P	3 BM	
		W4-4P		36"X18"	✓							
48	2	R1-1		48"X48"	✓		S80	1	SA	T		
		W4-4P		36"X18"	✓							
48	3	W3-1		36"X36"	✓		TWT	1	WS	T		
54	4	R1-1		48"X48"	✓		S80	1	SA	P	3 BM	
		W4-4P		36"X18"	✓							
54	5	W3-1		36"X36"	✓		TWT	1	WS	T		
54	6	W3-1		36"X36"	✓		TWT	1	WS	T		
59	7	R1-1		48"X48"	✓		S80	1	SA	P	3 BM	
		W4-4P		36"X18"	✓							
59	8	W3-1		36"X36"	✓		TWT	1	WS	T		

ALUMINUM SIGN BLANKS THICKNESS	
Square Feet	Minimum Thickness
Less than 7.5	0.080"
7.5 to 15	0.100"
Greater than 15	0.125"

The Standard Highway Sign Designs for Texas (SHSD) can be found at the following website.
<http://www.txdot.gov/>

- NOTE:**
- Sign supports shall be located as shown on the plans, except that the Engineer may shift the sign supports, within design guidelines, where necessary to secure a more desirable location or to avoid conflict with utilities. Unless otherwise shown on the plans, the Contractor shall stake and the Engineer will verify all sign support locations.
 - For installation of bridge mount clearance signs, see Bridge Mounted Clearance Sign Assembly (BMCS) Standard Sheet.
 - For Sign Support Descriptive Codes, see Sign Mounting Details Small Roadside Signs General Notes & Details SMD(GEN).

SHEET 1 OF 5



SUMMARY OF SMALL SIGNS

SOSS

FILE: slums16.dgn	DN: TxDOT	CK: TxDOT	DW: TxDOT	CR: TxDOT
© TxDOT May 1987	CONT	SECT	JOB	HIGHWAY
REVISIONS	0010	08	060	US 67
4-16	DIST	COUNTY	SHEET NO.	
8-16	ATL	MORRIS	9	

DISCLAIMER: The use of this standard is governed by the "Texas Engineering Practice Act". No warranty of any kind is made by TxDOT for any purpose whatsoever. TxDOT assumes no responsibility for the conversion of this standard to other formats or for incorrect results or damages resulting from its use.

DATE: 1/25/2024 1:29:50 PM
FILE: I:\engdata\Traffic\DGND\192515_Jamie\JOBS\LIGHTING PROJECTS\Lighting Project May 2024\slums16 (1).dgn

SUMMARY OF SMALL SIGNS

PLAN SHEET NO.	SIGN NO.	SIGN NOMENCLATURE	SIGN	DIMENSIONS	FLAT ALUMINUM (TYPE A)	EXAL ALUMINUM (TYPE G)	SM RD SGN ASSM TY XXXXX (X) XX (X-XXXX)				BRIDGE MOUNT CLEARANCE SIGNS (See Note 2)	
							POST TYPE	POSTS	ANCHOR TYPE	MOUNTING DESIGNATION		
										PREFABRICATED		1EXT or 2EXT = # of Ext
							FRP = Fiberglass TWT = Thin-Wall 10BWG = 10 BWG S80 = Sch 80	1 or 2	UA=Universal Conc UB=Universal Bolt SA=Slipbase-Conc SB=Slipbase-Bolt WS=Wedge Steel WP=Wedge Plastic	P = "Plain" T = "T" U = "U"	BM = Extruded Wind Beam WC = 1.12 #/ft Wing Channel EXAL= Extruded Alum Sign Panels	TY = TYPE TY N TY S
59	9	W3-1		36"X36"	✓			TWT	1	WS	T	
67	10	W3-1		36"X36"	✓			TWT	1	WS	T	
67	11	R1-1		48"X48"	✓			S80	1	SA	P	3 BM
		R1-3P		30"X12"	✓							
67	12A	R1-1		48"X48"	✓			S80	1	SA	P	3 BM
		R1-3P		30"X12"	✓							
	12B	M1-6F		24"X24"	✓							
		M6-4		21"X15"	✓							
67	13A	R1-1		48"X48"	✓			S80	1	SA	P	3 BM
		R1-3P		30"X12"	✓							
	13B	M1-6F		24"X24"	✓							
		M6-4		21"X15"	✓							

ALUMINUM SIGN BLANKS THICKNESS	
Square Feet	Minimum Thickness
Less than 7.5	0.080"
7.5 to 15	0.100"
Greater than 15	0.125"

The Standard Highway Sign Designs for Texas (SHSD) can be found at the following website.
<http://www.txdot.gov/>

- NOTE:**
- Sign supports shall be located as shown on the plans, except that the Engineer may shift the sign supports, within design guidelines, where necessary to secure a more desirable location or to avoid conflict with utilities. Unless otherwise shown on the plans, the Contractor shall stake and the Engineer will verify all sign support locations.
 - For installation of bridge mount clearance signs, see Bridge Mounted Clearance Sign Assembly (BMCS) Standard Sheet.
 - For Sign Support Descriptive Codes, see Sign Mounting Details Small Roadside Signs General Notes & Details SMD(GEN).

SHEET 2 OF 5



SUMMARY OF SMALL SIGNS

SOSS

FILE: slums16.dgn	DN: TxDOT	CK: TxDOT	DW: TxDOT	CR: TxDOT
© TxDOT May 1987	CONT	SECT	JOB	HIGHWAY
REVISIONS	0010	08	060	US 67
4-16	DIST	COUNTY	SHEET NO.	
8-16	ATL	MORRIS	10	

DISCLAIMER: The use of this standard is governed by the "Texas Engineering Practice Act". No warranty of any kind is made by TxDOT for any purpose whatsoever. TxDOT assumes no responsibility for the conversion of this standard to other formats or for incorrect results or damages resulting from its use.

DATE: 1/25/2024 1:30:34 PM
FILE: I:\engdata\Traffic\DGND\192515_Jamie\JOBS\LIGHTING PROJECTS\Lighting Project May 2024\sums16 (1).dgn

SUMMARY OF SMALL SIGNS

PLAN SHEET NO.	SIGN NO.	SIGN NOMENCLATURE	SIGN	DIMENSIONS	FLAT ALUMINUM (TYPE A)	EXAL ALUMINUM (TYPE G)	SM RD SGN ASSM TY XXXXX (X) XX (X-XXXX)				BRIDGE MOUNT CLEARANCE SIGNS (See Note 2)	
							POST TYPE	POSTS	ANCHOR TYPE	MOUNTING DESIGNATION		
							FRP = Fiberglass TWT = Thin-Wall 10BWG = 10 BWG S80 = Sch 80	1 or 2	UA=Universal Conc UB=Universal Bolt SA=Slipbase-Conc SB=Slipbase-Bolt WS=Wedge Steel WP=Wedge Plastic	PREFABRICATED P = "Plain" T = "T" U = "U"		1EXT or 2EXT = # of Ext BM = Extruded Wind Beam WC = 1.12 #/ft Wing Channel EXAL= Extruded Alum Sign Panels
67	14	R1-1		48"X48"	✓		S80	1	SA	P	3 BM	
		R1-3P		30"X12"	✓							
67	15	W3-1		36"X36"	✓		TWT	1	WS	T		
67	16	W3-1		36"X36"	✓		TWT	1	WS	T		
67	17	W3-1		36"X36"	✓		TWT	1	WS	T		
67	18A	R1-1		48"X48"	✓		S80	1	SA	P	3 BM	
		R1-3P		30"X12"	✓							
	18B	M1-6F		24"X24"	✓							
		M6-4		21"X15"	✓							
67	19	R1-1		48"X48"	✓		S80	1	SA	P	3 BM	
		R1-3P		30"X12"	✓							
67	20	R1-1		48"X48"	✓		S80	1	SA	P	3 BM	
		R1-3P		30"X12"	✓							

DISCLAIMER: The use of this standard is governed by the "Texas Engineering Practice Act". No warranty of any kind is made by TxDOT for any purpose whatsoever. TxDOT assumes no responsibility for the conversion of this standard to other formats or for incorrect results or damages resulting from its use.

DATE: 1/25/2024 1:31:21 PM
 FILE: T:\engdata\Traffic\DGND\192515_Jamie\JOBS\LIGHTING PROJECTS\Lighting Project May 2024\sums16 (1).dgn

ALUMINUM SIGN BLANKS THICKNESS	
Square Feet	Minimum Thickness
Less than 7.5	0.080"
7.5 to 15	0.100"
Greater than 15	0.125"

The Standard Highway Sign Designs for Texas (SHSD) can be found at the following website:
<http://www.txdot.gov/>

- NOTE:**
- Sign supports shall be located as shown on the plans, except that the Engineer may shift the sign supports, within design guidelines, where necessary to secure a more desirable location or to avoid conflict with utilities. Unless otherwise shown on the plans, the Contractor shall stake and the Engineer will verify all sign support locations.
 - For installation of bridge mount clearance signs, see Bridge Mounted Clearance Sign Assembly (BMCS) Standard Sheet.
 - For Sign Support Descriptive Codes, see Sign Mounting Details Small Roadside Signs General Notes & Details SMD(GEN).

SHEET 3 OF 5



SUMMARY OF SMALL SIGNS

SOSS

FILE: sums16.dgn	DN: TxDOT	CK: TxDOT	DW: TxDOT	CR: TxDOT
© TxDOT May 1987	CONT	SECT	JOB	HIGHWAY
REVISIONS	0010	08	060	US 67
4-16	DIST	COUNTY	SHEET NO.	
8-16	ATL	MORRIS		11

SUMMARY OF SMALL SIGNS

PLAN SHEET NO.	SIGN NO.	SIGN NOMENCLATURE	SIGN	DIMENSIONS	FLAT ALUMINUM (TYPE A)	EXAL ALUMINUM (TYPE G)	SM RD SGN ASSM TY XXXXX (X) XX (X-XXXX)				BRIDGE MOUNT CLEARANCE SIGNS (See Note 2)	
							POST TYPE	POSTS	ANCHOR TYPE	MOUNTING DESIGNATION		
							FRP = Fiberglass TWT = Thin-Wall 10BWG = 10 BWG S80 = Sch 80	1 or 2	UA=Universal Conc UB=Universal Bolt SA=Slipbase-Conc SB=Slipbase-Bolt WS=Wedge Steel WP=Wedge Plastic	PREFABRICATED P = "Plain" T = "T" U = "U"		1EXT or 2EXT = # of Ext BM = Extruded Wind Beam WC = 1.12 #/ft Wing Channel EXAL= Extruded Alum Sign Panels
67	21A	R1-1		48"X48"	✓		S80	1	SA	P	3 BM	
		R1-3P		30"X12"	✓							
	21B	M1-6F		24"X24"	✓							
		M6-4		21"X15"	✓							
67	22	W3-1		36"X36"	✓		TWT	1	WS	T		
67	23	W3-1		36"X36"	✓		TWT	1	WS	T		
71	24	W3-1		36"X36"	✓		TWT	1	WS	T		
71	25	W3-1		36"X36"	✓		TWT	1	WS	T		
71	26	R1-1		48"X48"	✓		S80	1	SA	P	3 BM	
		R1-3P		30"X12"	✓							
71	27	W3-1		36"X36"	✓		TWT	1	WS	T		

MOUNTED BACK TO BACK
SINGLE SIGN MOUNT.

ALUMINUM SIGN BLANKS THICKNESS	
Square Feet	Minimum Thickness
Less than 7.5	0.080"
7.5 to 15	0.100"
Greater than 15	0.125"

The Standard Highway Sign Designs for Texas (SHSD) can be found at the following website.
<http://www.txdot.gov/>

- NOTE:**
- Sign supports shall be located as shown on the plans, except that the Engineer may shift the sign supports, within design guidelines, where necessary to secure a more desirable location or to avoid conflict with utilities. Unless otherwise shown on the plans, the Contractor shall stake and the Engineer will verify all sign support locations.
 - For installation of bridge mount clearance signs, see Bridge Mounted Clearance Sign Assembly (BMCS) Standard Sheet.
 - For Sign Support Descriptive Codes, see Sign Mounting Details Small Roadside Signs General Notes & Details SMD(GEN).

SHEET 4 OF 5



SUMMARY OF SMALL SIGNS

SOSS

FILE: slums16.dgn	DN: TxDOT	CK: TxDOT	DW: TxDOT	CR: TxDOT
© TxDOT May 1987	CONT	SECT	JOB	HIGHWAY
REVISIONS	0010	08	060	US 67
4-16	DIST	COUNTY	SHEET NO.	
8-16	ATL	MORRIS	12	

DISCLAIMER: The use of this standard is governed by the "Texas Engineering Practice Act". No warranty of any kind is made by TxDOT for any purpose whatsoever. TxDOT assumes no responsibility for the conversion of this standard to other formats or for incorrect results or damages resulting from its use.

DATE: 1/25/2024 1:36:47 PM
 FILE: I:\engdata\Traffic\Lighting\PROJECTS\Lighting Project May 2024\sums16 (1).dgn

SUMMARY OF SMALL SIGNS

PLAN SHEET NO.	SIGN NO.	SIGN NOMENCLATURE	SIGN	DIMENSIONS	FLAT ALUMINUM (TYPE A)	EXAL ALUMINUM (TYPE G)	SM RD SGN ASSM TY XXXXX (X) XX (X-XXXX)				BRIDGE MOUNT CLEARANCE SIGNS (See Note 2)
							POST TYPE	POSTS	ANCHOR TYPE	MOUNTING DESIGNATION	
							FRP = Fiberglass TWT = Thin-Wall 10BWG = 10 BWG S80 = Sch 80	1 or 2	UA=Universal Conc UB=Universal Bolt SA=Slipbase-Conc SB=Slipbase-Bolt WS=Wedge Steel WP=Wedge Plastic	PREFABRICATED P = "Plain" T = "T" U = "U" 1EXT or 2EXT = # of Ext BM = Extruded Wind Beam WC = 1.12 #/ft Wing Channel EXAL= Extruded Alum Sign Panels	
71	28	W3-1		36"X36"	✓		TWT	1	WS	T	
71	29	R1-1		48"X48"	✓		S80	1	SA	P	3 BM
		R1-3P		30"X12"	✓						
71	30	W3-1		36"X36"	✓		TWT	1	WS	T	
71	31	W3-1		36"X36"	✓		TWT	1	WS	T	
71	32	R1-1		48"X48"	✓		S80	1	SA	P	3 BM
		R1-3P		30"X12"	✓						
71	33	W3-1		36"X36"	✓		TWT	1	WS	T	
71	34	W3-1		36"X36"	✓		TWT	1	WS	T	
71	35	R1-1		48"X48"	✓		S80	1	SA	P	3 BM
		R1-3P		30"X12"	✓						

ALUMINUM SIGN BLANKS THICKNESS	
Square Feet	Minimum Thickness
Less than 7.5	0.080"
7.5 to 15	0.100"
Greater than 15	0.125"

The Standard Highway Sign Designs for Texas (SHSD) can be found at the following website.
<http://www.txdot.gov/>

- NOTE:**
- Sign supports shall be located as shown on the plans, except that the Engineer may shift the sign supports, within design guidelines, where necessary to secure a more desirable location or to avoid conflict with utilities. Unless otherwise shown on the plans, the Contractor shall stake and the Engineer will verify all sign support locations.
 - For installation of bridge mount clearance signs, see Bridge Mounted Clearance Sign Assembly (BMCS) Standard Sheet.
 - For Sign Support Descriptive Codes, see Sign Mounting Details Small Roadside Signs General Notes & Details SMD(GEN).

SHEET 5 OF 5



SUMMARY OF SMALL SIGNS

SOSS

FILE: slums16.dgn	DN: TxDOT	CK: TxDOT	DW: TxDOT	CR: TxDOT
© TxDOT May 1987	CONT	SECT	JOB	HIGHWAY
REVISIONS	0010	08	060	US 67
4-16	DIST	COUNTY	SHEET NO.	
8-16	ATL	MORRIS	13	

DISCLAIMER: The use of this standard is governed by the "Texas Engineering Practice Act". No warranty of any kind is made by TxDOT for any purpose whatsoever. TxDOT assumes no responsibility for the conversion of this standard to other formats or for incorrect results or damages resulting from its use.

DATE: 1/25/2024 1:37:50 PM
FILE: I:\engdata\Traffic\DGND\192515_Jamie\JOBS\LIGHTING PROJECTS\Lighting Project May 2024\sums16 (1).dgn

DATE: 1/11/2024 1:27:57 PM
 FILE: I:\Engdat\Traffic\JG\192515_Jamie\JOBS\LIGHTING PROJECTS\Lighting Project May 2024\Standard\BC-21.dgn
 No. warranty of any kind is made by TxDOT or any purpose whatsoever. TxDOT assumes no responsibility for the conversion of this standard to any other project. May 2024 Standard BC-21.dgn

BARRICADE AND CONSTRUCTION (BC) STANDARD SHEETS GENERAL NOTES:

- The Barricade and Construction Standard Sheets (BC sheets) are intended to show typical examples for placement of temporary traffic control devices, construction pavement markings, and typical work zone signs. The information contained in these sheets meet or exceed the requirements shown in the "Texas Manual on Uniform Traffic Control Devices" (TMUTCD).
- The development and design of the Traffic Control Plan (TCP) is the responsibility of the Engineer.
- The Contractor may propose changes to the TCP that are signed and sealed by a licensed professional engineer for approval. The Engineer may develop, sign and seal Contractor proposed changes.
- The Contractor is responsible for installing and maintaining the traffic control devices as shown in the plans. The Contractor may not move or change the approximate location of any device without the approval of the Engineer.
- Geometric design of lane shifts and detours should, when possible, meet the applicable design criteria contained in manuals such as the American Association of State Highway and Transportation Officials (AASHTO), "A Policy on Geometric Design of Highways and Streets," the TxDOT "Roadway Design Manual" or engineering judgment.
- When projects abut, the Engineer(s) may omit the END ROAD WORK, TRAFFIC FINES DOUBLE, and other advance warning signs if the signing would be redundant and the work areas appear continuous to the motorists. If the adjacent project is completed first, the Contractor shall erect the necessary warning signs as shown on these sheets, the TCP sheets or as directed by the Engineer. The BEGIN ROAD WORK NEXT X MILES sign shall be revised to show appropriate work zone distance.
- The Engineer may require duplicate warning signs on the median side of divided highways where median width will permit and traffic volumes justify the signing.
- All signs shall be constructed in accordance with the details found in the "Standard Highway Sign Designs for Texas," latest edition. Sign details not shown in this manual shall be shown in the plans or the Engineer shall provide a detail to the Contractor before the sign is manufactured.
- The temporary traffic control devices shown in the illustrations of the BC sheets are examples. As necessary, the Engineer will determine the most appropriate traffic control devices to be used.
- Where highway construction or maintenance work is being undertaken, other than mobile operations as defined by the Texas Manual on Uniform Traffic Control Devices, CSJ limit signs are required. CSJ limit signs are shown on BC(2). The OBEY WARNING SIGNS STATE LAW sign, STAY ALERT TALK OR TEXT LATER and the WORK ZONE TRAFFIC FINES DOUBLE sign with plaque shall be erected in advance of the CSJ limits. The BEGIN ROAD WORK NEXT X MILES, CONTRACTOR and END ROAD WORK signs shall be erected at or near the CSJ limits. For mobile operations, CSJ limit signs are not required.
- Traffic control devices should be in place only while work is actually in progress or a definite need exists.
- The Engineer has the final decision on the location of all traffic control devices.
- Inactive equipment and work vehicles, including workers' private vehicles must be parked away from travel lanes. They should be as close to the right-of-way line as possible, or located behind a barrier or guardrail, or as approved by the Engineer.

WORKER SAFETY NOTES:

- Workers on foot who are exposed to traffic or to construction equipment within the right-of-way shall wear high-visibility safety apparel meeting the requirements of ISEA "American National Standard for High-Visibility Apparel," or equivalent revisions, and labeled as ANSI 107-2004 standard performance for Class 2 or 3 risk exposure. Class 3 garments should be considered for high traffic volume work areas or night time work.
- Except in emergency situations, flagger stations shall be illuminated when flagging is used at night.

COMPLIANT WORKZONE TRAFFIC CONTROL DEVICES

- Only pre-qualified products shall be used. The "Compliant Work Zone Traffic Control Devices List" (CWZTCD) describes pre-qualified products and their sources.
- Work zone traffic control devices shall be compliant with the Manual for Assessing safety Hardware (MASH).

THE DOCUMENTS BELOW CAN BE FOUND ON-LINE AT http://www.txdot.gov
COMPLIANT WORK ZONE TRAFFIC CONTROL DEVICES LIST (CWZTCD)
DEPARTMENTAL MATERIAL SPECIFICATIONS (DMS)
MATERIAL PRODUCER LIST (MPL)
ROADWAY DESIGN MANUAL - SEE "MANUALS (ONLINE MANUALS)"
STANDARD HIGHWAY SIGN DESIGNS FOR TEXAS (SHSD)
TEXAS MANUAL ON UNIFORM TRAFFIC CONTROL DEVICES (TMUTCD)
TRAFFIC ENGINEERING STANDARD SHEETS

SHEET 1 OF 12

 Texas Department of Transportation		Traffic Safety Division Standard	
BARRICADE AND CONSTRUCTION GENERAL NOTES AND REQUIREMENTS			
BC (1) -21			
FILE:	bc-21.dgn	DN:	TxDOT
© TxDOT	November 2002	CK:	TxDOT
		DW:	TxDOT
		CK:	TxDOT
REVISIONS	CONT	SECT	JOB
4-03 7-13	0010	08	060
9-07 8-14			US 67
5-10 5-21	DIST	COUNTY	SHEET NO.
	ATL	MORRIS	14

DATE: 1/11/2024 1:28:36 PM
 FILE: T:\engdata\Traffic\Lighting\Projects\Lighting\Projects\192515_Jamie\JOBS\LIGHTING PROJECTS\Lighting\Projects\192515_Jamie.dgn
 The use of this standard is governed by the "Texas Engineering Practice Act". No warranty of any kind is made by TxDOT for any purpose whatsoever. TxDOT assumes no responsibility for the conversion of this standard to any other format or for any errors or omissions that may appear hereon.

TYPICAL LOCATION OF CROSSROAD SIGNS

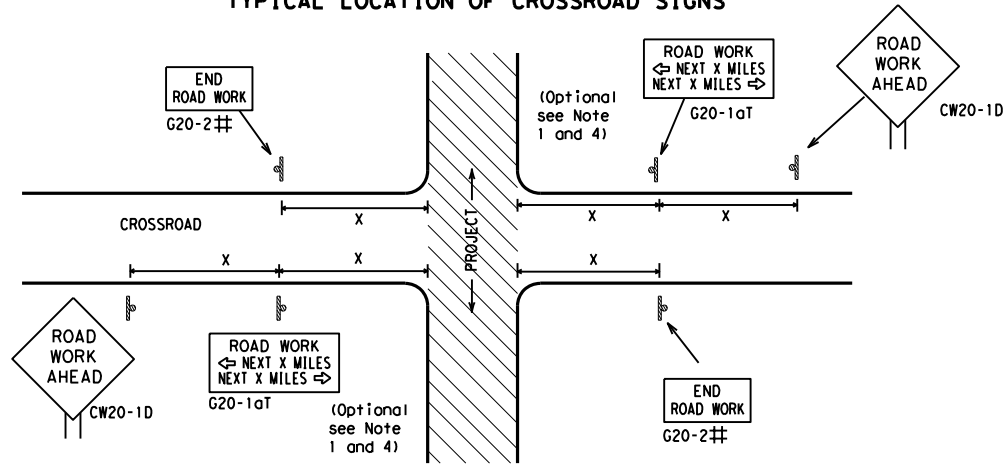

May be mounted on back of "ROAD WORK AHEAD" (CW20-1D) sign with approval of Engineer. (See note 2 below)

- The typical minimum signing on a crossroad approach should be a "ROAD WORK AHEAD" (CW20-1D) sign and a (G20-2) "END ROAD WORK" sign, unless noted otherwise in plans.
- The Engineer may use the reduced size 36" x 36" ROAD WORK AHEAD (CW20-1D) sign mounted back to back with the reduced size 36" x 18" "END ROAD WORK" (G20-2) sign on low volume crossroads (see Note 4 under "Typical Construction Warning Sign Size and Spacing"). See the "Standard Highway Sign Designs for Texas" manual for sign details. The Engineer may omit the advance warning signs on low volume crossroads. The Engineer will determine whether a road is low volume as per TMUTCD Part 5. This information shall be shown in the plans.
- Based on existing field conditions, the Engineer/Inspector may require additional signs such as FLAGGER AHEAD, LOOSE GRAVEL, or other appropriate signs. When additional signs are required, these signs will be considered part of the minimum requirements. The Engineer/Inspector will determine the proper location and spacing of any sign not shown on the BC sheets, Traffic Control Plan sheets or the Work Zone Standard Sheets.
- The "ROAD WORK NEXT X MILES" (G20-1aT) sign shall be required at high volume crossroads to advise motorists of the length of construction in either direction from the intersection. The Engineer will determine whether a roadway is considered high volume.
- Additional traffic control devices may be shown elsewhere in the plans for higher volume crossroads.
- When work occurs in the intersection area, appropriate traffic control devices, as shown elsewhere in the plans or as determined by the Engineer/Inspector, shall be in place.

T-INTERSECTION

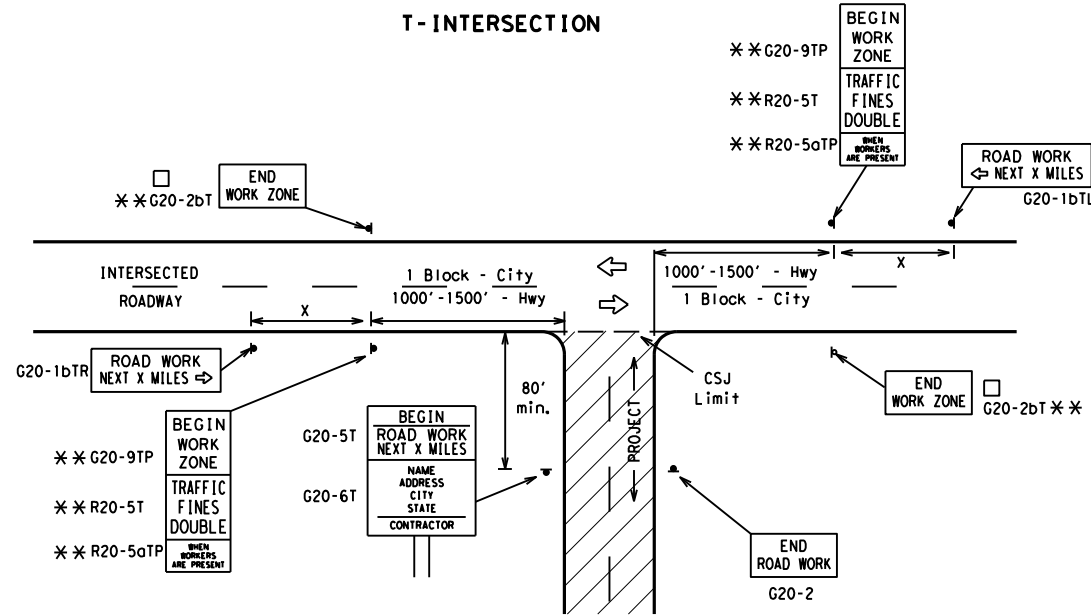

CSJ LIMITS AT T-INTERSECTION

- The Engineer will determine the types and location of any additional traffic control devices, such as a flagger and accompanying signs, or other signs, that should be used when work is being performed at or near an intersection.
- If construction closes the road at a T-intersection, the Contractor shall place the "CONTRACTOR NAME" (G20-6T) sign behind the Type 3 Barricades for the road closure (see BC(10) also). The "ROAD WORK NEXT X MILES" left arrow (G20-1bTL) and "ROAD WORK NEXT X MILES" right arrow (G20-1bTR) signs shall be replaced by the detour signing called for in the plans.

TYPICAL CONSTRUCTION WARNING SIGN SIZE AND SPACING^{1,5,6}

Sign Number or Series	SIZE		SPACING	
	Conventional Road	Expressway/Freeway	Posted Speed MPH	Sign Δ Spacing "x" Feet (Apprx.)
CW20 ⁴	48" x 48"	48" x 48"	30	120
CW21			35	160
CW22			40	240
CW23			45	320
CW25			50	400
CW1, CW2, CW7, CW8, CW9, CW11, CW14	36" x 36"	48" x 48"	55	500 ²
CW3, CW4, CW5, CW6, CW8-3, CW10, CW12	48" x 48"	48" x 48"	60	600 ²
			65	700 ²
			70	800 ²
			75	900 ²
			80	1000 ²
			*	* ³

* For typical sign spacings on divided highways, expressways and freeways, see Part 6 of the "Texas Manual on Uniform Traffic Control Devices" (TMUTCD) typical application diagrams or TCP Standard Sheets.

Δ Minimum distance from work area to first Advance Warning sign nearest the work area and/or distance between each additional sign.

GENERAL NOTES

- Special or larger size signs may be used as necessary.
- Distance between signs should be increased as required to have 1500 feet advance warning.
- Distance between signs should be increased as required to have 1/2 mile or more advance warning.
- 36" x 36" "ROAD WORK AHEAD" (CW20-1D) signs may be used on low volume crossroads at the discretion of the Engineer as per TMUTCD Part 5. See Note 2 under "Typical Location of Crossroad Signs".
- Only diamond shaped warning sign sizes are indicated.
- See sign size listing in "TMUTCD", Sign Appendix or the "Standard Highway Sign Designs for Texas" manual for complete list of available sign design sizes.

WORK AREAS IN MULTIPLE LOCATIONS WITHIN CSJ LIMITS

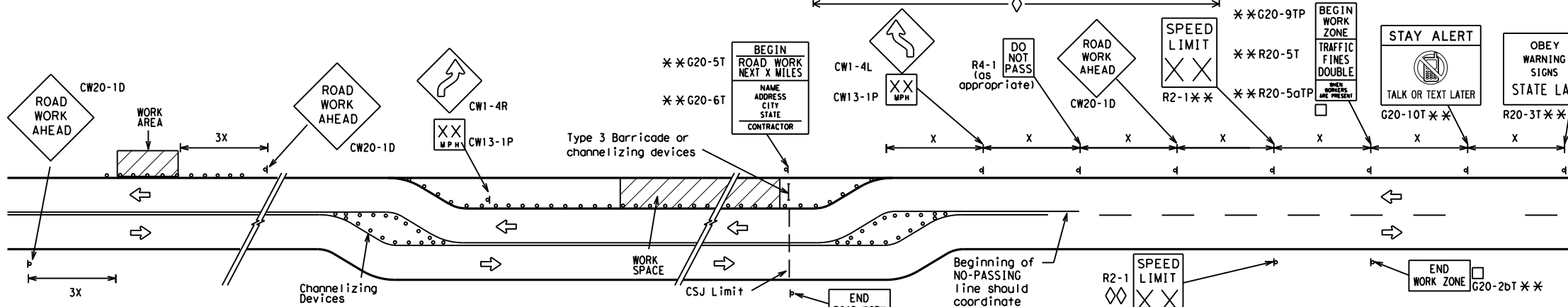

When extended distances occur between minimal work spaces, the Engineer/Inspector should ensure additional "ROAD WORK AHEAD" (CW20-1D) signs are placed in advance of these work areas to remind drivers they are still within the project limits. See the applicable TCP sheets for exact location and spacing of signs and channelizing devices.

SAMPLE LAYOUT OF SIGNING FOR WORK BEGINNING DOWNSTREAM OF THE CSJ LIMITS

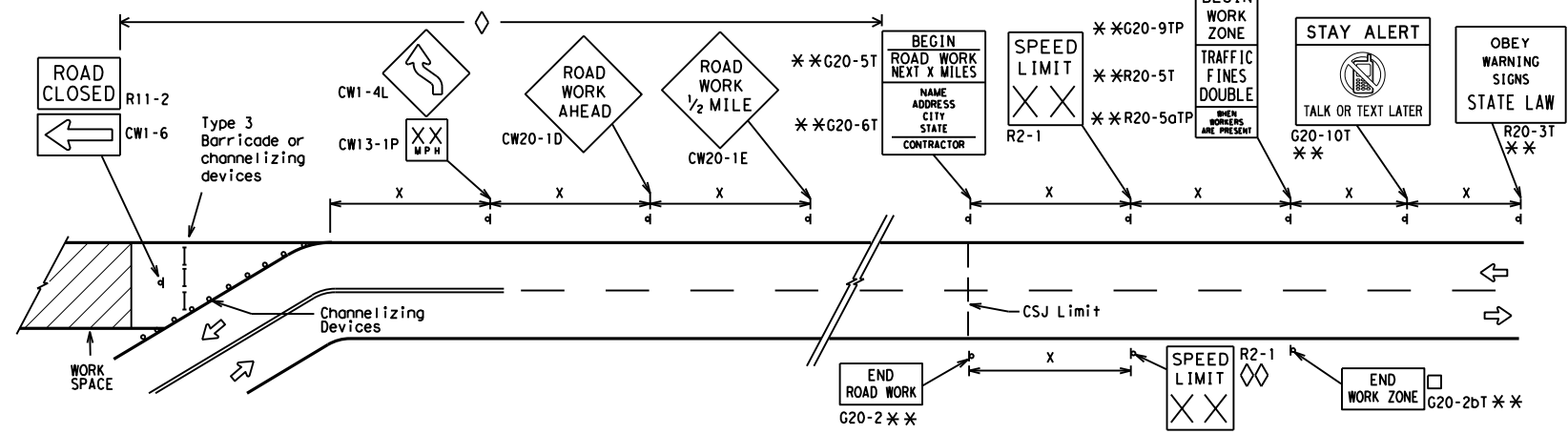

NOTES

- The Contractor shall determine the appropriate distance to be placed on the G20-1 series signs and "BEGIN ROAD WORK NEXT X MILES" (G20-5T) sign for each specific project. This distance shall replace the "x" and shall be rounded to the nearest whole mile with the approval of the Engineer. No decimals shall be used.
- The "BEGIN WORK ZONE" (G20-9TP) and "END WORK ZONE" (G20-2bT) shall be used as shown on the sample layout when advance signs are required outside the CSJ Limits. They inform the motorist of entering or leaving a part of the work zone lying outside the CSJ Limits where traffic fines may double if workers are present.
- CSJ limit signing is required for highway construction and maintenance work, with the exception of mobile operations.
- Area for placement of "ROAD WORK AHEAD" (CW20-1D) sign and other signs or devices as called for on the Traffic Control Plan.
- Contractor will install a regulatory speed limit sign at the end of the work zone.

LEGEND	
—	Type 3 Barricade
○ ○ ○	Channelizing Devices
■	Sign
X	See Typical Construction Warning Sign Size and Spacing chart or the TMUTCD for sign spacing requirements.

SHEET 2 OF 12



BARRICADE AND CONSTRUCTION PROJECT LIMIT

BC(2)-21

FILE: bc-21.dgn	DN: TxDOT	CK: TxDOT	DW: TxDOT	CR: TxDOT
© TxDOT November 2002	CONT	SECT	JOB	HIGHWAY
REVISIONS	0010	08	060	US 67
9-07 8-14	DIST	COUNTY	SHEET NO.	
7-13 5-21	ATL	MORRIS	15	

DISCLAIMER: The use of this standard is governed by the "Texas Engineering Practice Act". No warranty of any kind is made by TxDOT for any purpose whatsoever. TxDOT assumes no responsibility for the conversion of this standard to other formats or for incorrect results or damages resulting from its use.

DATE: 1/11/2024 1:29:37 PM
 FILE: T:\Engdat\Traffic\UGM\192515_Jamie\JOBS\LIGHTING PROJECTS\Lighting Project May 2024\standards\bc-21 (1).dgn

TYPICAL MINIMUM CLEARANCES FOR LONG TERM AND INTERMEDIATE TERM SIGNS

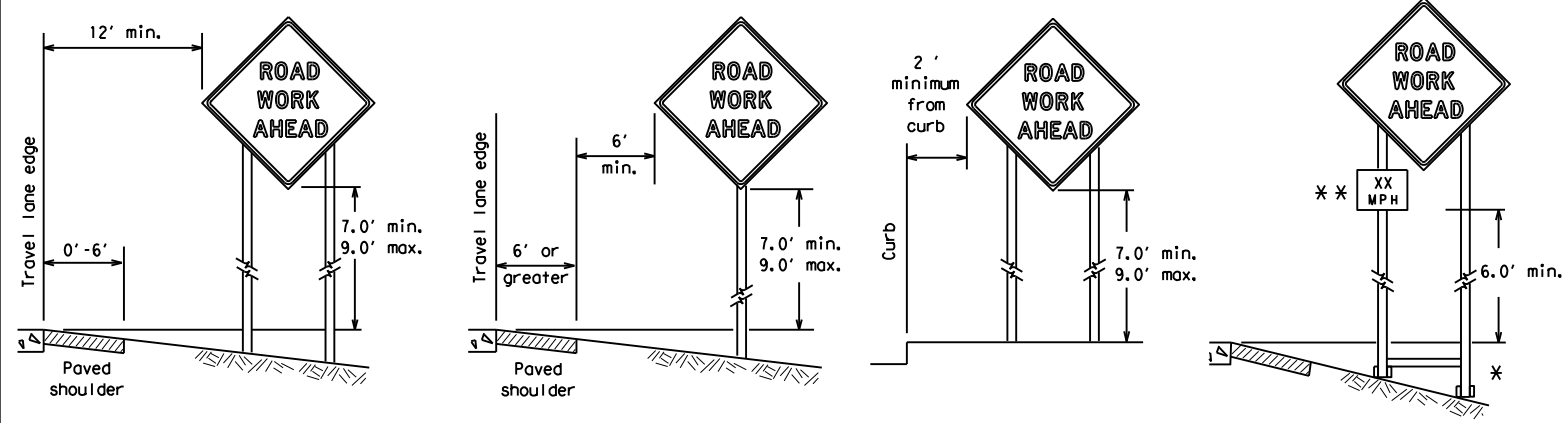

* When placing skid supports on unlevel ground, the leg post lengths must be adjusted so the sign appears straight and plumb. Objects shall NOT be placed under skids as a means of leveling.

** When plaques are placed on dual-leg supports, they should be attached to the upright nearest the travel lane. Supplemental plaques (advisory or distance) should not cover the surface of the parent sign.

GENERAL NOTES FOR WORK ZONE SIGNS

- Contractor shall install and maintain signs in a straight and plumb condition and/or as directed by the Engineer.
- Wooden sign posts shall be painted white.
- Barricades shall NOT be used as sign supports.
- All signs shall be installed in accordance with the plans or as directed by the Engineer. Signs shall be used to regulate, warn, and guide the traveling public safely through the work zone.
- The Contractor may furnish either the sign design shown in the plans or in the "Standard Highway Sign Designs for Texas" (SHSD). The Engineer/Inspector may require the Contractor to furnish other work zone signs that are shown in the TMUTCD but may have been omitted from the plans. Any variation in the plans shall be documented by written agreement between the Engineer and the Contractor's Responsible Person. All changes must be documented in writing before being implemented. This can include documenting the changes in the Inspector's TxDOT diary and having both the Inspector and Contractor initial and date the agreed upon changes.
- The Contractor shall furnish sign supports listed in the "Compliant Work Zone Traffic Control Device List" (CWZTCD) for small roadside signs. Supports for temporary large roadside signs shall meet the requirements detailed on the Temporary Large Roadside Signs (TLRS) standard sheets. The Contractor shall install the sign support in accordance with the manufacturer's recommendations. If there is a question regarding installation procedures, the Contractor shall furnish the Engineer a copy of the manufacturer's installation recommendations so the Engineer can verify the correct procedures are being followed.
- The Contractor is responsible for installing signs on approved supports and replacing signs with damaged or cracked substrates and/or damaged or marred reflective sheeting as directed by the Engineer/Inspector.
- Identification markings may be shown only on the back of the sign substrate. The maximum height of letters and/or company logos used for identification shall be 1 inch.
- The Contractor shall replace damaged wood posts. New or damaged wood sign posts shall not be spliced.

DURATION OF WORK (as defined by the "Texas Manual on Uniform Traffic Control Devices" Part 6)

- The types of sign supports, sign mounting height, the size of signs, and the type of sign substrates can vary based on the type of work being performed. The Engineer is responsible for selecting the appropriate size sign for the type of work being performed. The Contractor is responsible for ensuring the sign support, sign mounting height and substrate meets manufacturer's recommendations in regard to crashworthiness and duration of work requirements.
 - Long-term stationary - work that occupies a location more than 3 days.
 - Intermediate-term stationary - work that occupies a location more than one daylight period up to 3 days, or nighttime work lasting more than one hour.
 - Short-term stationary - daytime work that occupies a location for more than 1 hour in a single daylight period.
 - Short, duration - work that occupies a location up to 1 hour.
 - Mobile - work that moves continuously or intermittently (stopping for up to approximately 15 minutes.)

SIGN MOUNTING HEIGHT

- The bottom of Long-term/Intermediate-term signs shall be at least 7 feet, but not more than 9 feet, above the paved surface, except as shown for supplemental plaques mounted below other signs.
- The bottom of Short-term/Short Duration signs shall be a minimum of 1 foot above the pavement surface but no more than 2 feet above the ground.
- Long-term/Intermediate-term Signs may be used in lieu of Short-term/Short Duration signing.
- Short-term/Short Duration signs shall be used only during daylight and shall be removed at the end of the workday or raised to appropriate Long-term/Intermediate sign height.
- Regulatory signs shall be mounted at least 7 feet, but not more than 9 feet, above the paved surface regardless of work duration.

SIZE OF SIGNS

- The Contractor shall furnish the sign sizes shown on BC (2) unless otherwise shown in the plans or as directed by the Engineer.

SIGN SUBSTRATES

- The Contractor shall ensure the sign substrate is installed in accordance with the manufacturer's recommendations for the type of sign support that is being used. The CWZTCD lists each substrate that can be used on the different types and models of sign supports.
- "Mesh" type materials are NOT an approved sign substrate, regardless of the tightness of the weave.
- All wooden individual sign panels fabricated from 2 or more pieces shall have one or more plywood cleat, 1/2" thick by 6" wide, fastened to the back of the sign and extending fully across the sign. The cleat shall be attached to the back of the sign using wood screws that do not penetrate the face of the sign panel. The screws shall be placed on both sides of the splice and spaced at 6" centers. The Engineer may approve other methods of splicing the sign face.

REFLECTIVE SHEETING

- All signs shall be retroreflective and constructed of sheeting meeting the color and retro-reflectivity requirements of DMS-8300 for rigid signs or DMS-8310 for roll-up signs. The web address for DMS specifications is shown on BC(1).
- White sheeting, meeting the requirements of DMS-8300 Type A, shall be used for signs with a white background.
- Orange sheeting, meeting the requirements of DMS-8300 Type B_{FL} or Type C_{FL}, shall be used for rigid signs with orange backgrounds.

SIGN LETTERS

- All sign letters and numbers shall be clear, and open rounded type uppercase alphabet letters as approved by the Federal Highway Administration (FHWA) and as published in the "Standard Highway Sign Design for Texas" manual. Signs, letters and numbers shall be of first class workmanship in accordance with Department Standards and Specifications.

REMOVING OR COVERING

- When sign messages may be confusing or do not apply, the signs shall be removed or completely covered.
- Long-term stationary or intermediate stationary signs installed on square metal tubing may be turned away from traffic 90 degrees when the sign message is not applicable. This technique may not be used for signs installed in the median of divided highways or near any intersections where the sign may be seen from approaching traffic.
- Signs installed on wooden skids shall not be turned at 90 degree angles to the roadway. These signs should be removed or completely covered when not required.
- When signs are covered, the material used shall be opaque, such as heavy mil black plastic, or other materials which will cover the entire sign face and maintain their opaque properties under automobile headlights at night, without damaging the sign sheeting.
- Burlap shall NOT be used to cover signs.
- Duct tape or other adhesive material shall NOT be affixed to a sign face.
- Signs and anchor stubs shall be removed and holes backfilled upon completion of work.

SIGN SUPPORT WEIGHTS

- Where sign supports require the use of weights to keep from turning over, the use of sandbags with dry, cohesionless sand should be used.
- The sandbags will be tied shut to keep the sand from spilling and to maintain a constant weight.
- Rock, concrete, iron, steel or other solid objects shall not be permitted for use as sign support weights.
- Sandbags should weigh a minimum of 35 lbs and a maximum of 50 lbs.
- Sandbags shall be made of a durable material that tears upon vehicular impact. Rubber (such as tire inner tubes) shall NOT be used.
- Rubber ballasts designed for channelizing devices should not be used for ballast on portable sign supports. Sign supports designed and manufactured with rubber bases may be used when shown on the CWZTCD list.
- Sandbags shall only be placed along or laid over the base supports of the traffic control device and shall not be suspended above ground level or hung with rope, wire, chains or other fasteners. Sandbags shall be placed along the length of the skids to weigh down the sign support.
- Sandbags shall NOT be placed under the skid and shall not be used to level sign supports placed on slopes.

FLAGS ON SIGNS

- Flags may be used to draw attention to warning signs. When used, the flag shall be 16 inches square or larger and shall be orange or fluorescent red-orange in color. Flags shall not be allowed to cover any portion of the sign face.

ATTACHMENT FOR SIGN SUPPORTS

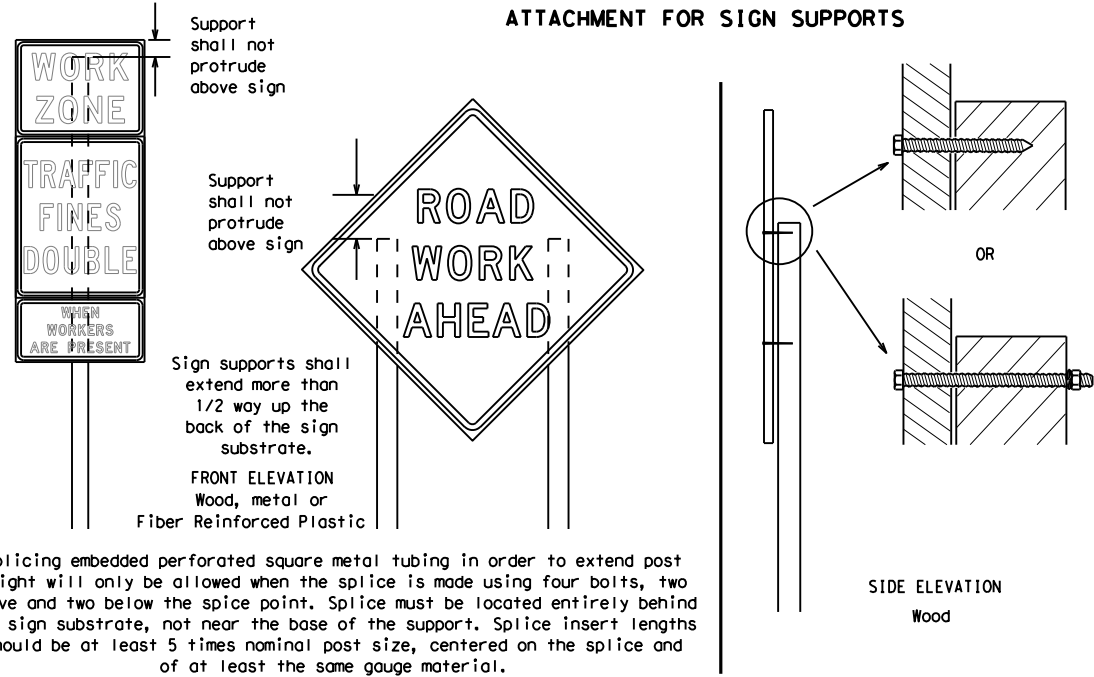

Splicing embedded perforated square metal tubing in order to extend post height will only be allowed when the splice is made using four bolts, two above and two below the splice point. Splice must be located entirely behind the sign substrate, not near the base of the support. Splice insert lengths should be at least 5 times nominal post size, centered on the splice and of at least the same gauge material.

STOP/SLOW PADDLES

- STOP/SLOW paddles are the primary method to control traffic by flaggers. The STOP/SLOW paddle size should be 24" x 24".
- STOP/SLOW paddles shall be retroreflectORIZED when used at night.
- STOP/SLOW paddles may be attached to a staff with a minimum length of 6' to the bottom of the sign.
- Any lights incorporated into the STOP or SLOW paddle faces shall only be as specifically described in Section 6E.03 Hand Signaling Devices in the TMUTCD.

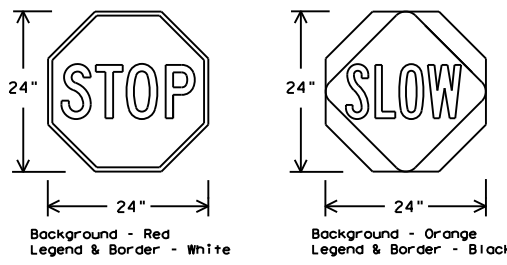

SHEETING REQUIREMENTS (WHEN USED AT NIGHT)		
USAGE	COLOR	SIGN FACE MATERIAL
BACKGROUND	RED	TYPE B OR C SHEETING
BACKGROUND	ORANGE	TYPE B _{FL} OR C _{FL} SHEETING
LEGEND & BORDER	WHITE	TYPE B OR C SHEETING
LEGEND & BORDER	BLACK	ACRYLIC NON-REFLECTIVE FILM

CONTRACTOR REQUIREMENTS FOR MAINTAINING PERMANENT SIGNS WITHIN THE PROJECT LIMITS

- Permanent signs are used to give notice of traffic laws or regulations, call attention to conditions that are potentially hazardous to traffic operations, show route designations, destinations, directions, distances, services, points of interest, and other geographical, recreational, specific service (LOGO), or cultural information. Drivers proceeding through a work zone need the same, if not better route guidance as normally installed on a roadway without construction.
- When permanent regulatory or warning signs conflict with work zone conditions, remove or cover the permanent signs until the permanent sign message matches the roadway condition. For details for covering large guide signs see the TS-CD standard.
- When existing permanent signs are moved and relocated due to construction purposes, they shall be visible to motorists at all times.
- If existing signs are to be relocated on their original supports, they shall be installed on crashworthy bases as shown on the SMD Standard sheets. The signs shall meet the required mounting heights shown on the BC Sheets or the SMD Standards. This work should be paid for under the appropriate pay item for relocating existing signs.
- If permanent signs are to be removed and relocated using temporary supports, the Contractor shall use crashworthy supports as shown on the BC standard sheets, TLRS standard sheets or the CWZTCD list. The signs shall meet the required mounting heights shown on the BC, or the SMD standard sheets during construction. This work should be paid for under the appropriate pay item for relocating existing signs.
- Any sign or traffic control device that is struck or damaged by the Contractor or his/her construction equipment shall be replaced as soon as possible by the Contractor to ensure proper guidance for the motorists. This will be subsidiary to Item 502.

SHEET 4 OF 12



BARRICADE AND CONSTRUCTION TEMPORARY SIGN NOTES

BC (4) - 21

FILE:	bc-21.dgn	DN:	TxDOT	CR:	TxDOT	OW:	TxDOT	CK:	TxDOT
© TxDOT	November 2002	CONT	SECT	JOB	HIGHWAY				
REVISIONS		0010	08	060	US 67				
9-07	8-14	DIST	COUNTY	SHEET NO.					
7-13	5-21	ATL	MORRIS	17					

DATE: 1/11/2024 1:59:48 PM
 FILE: T:\Engdara\Traffic\DGND192515_Jamie\JOBS\LIGHTING PROJECTS\Lighting Project_May 2024\standards\bc-21.dgn
 DISCLAIMER: The use of this standard is governed by the "Texas Engineering Practice Act". No warranty of any kind is made by TxDOT for any purpose whatsoever. TxDOT assumes no responsibility for the conversion of this standard to other formats or for incorrect results or damages resulting from its use.

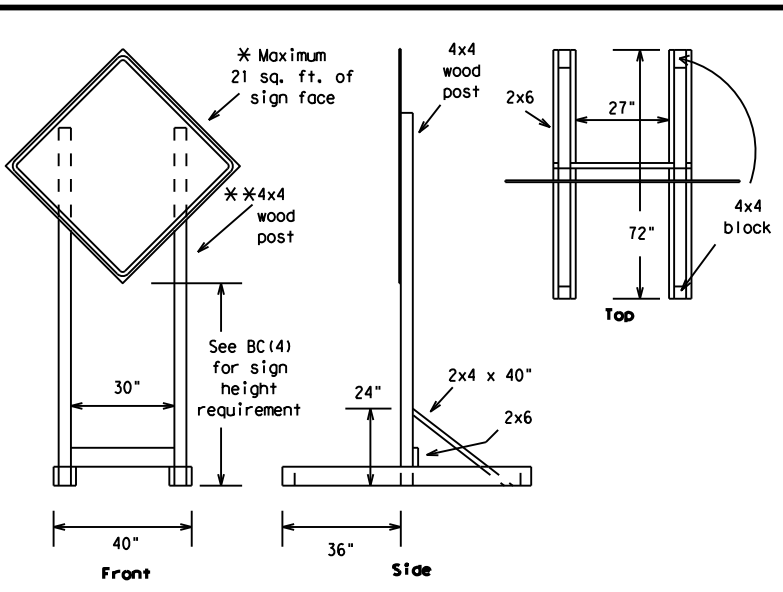

SKID MOUNTED WOOD SIGN SUPPORTS

* LONG/INTERMEDIATE TERM STATIONARY - PORTABLE SKID MOUNTED SIGN SUPPORTS

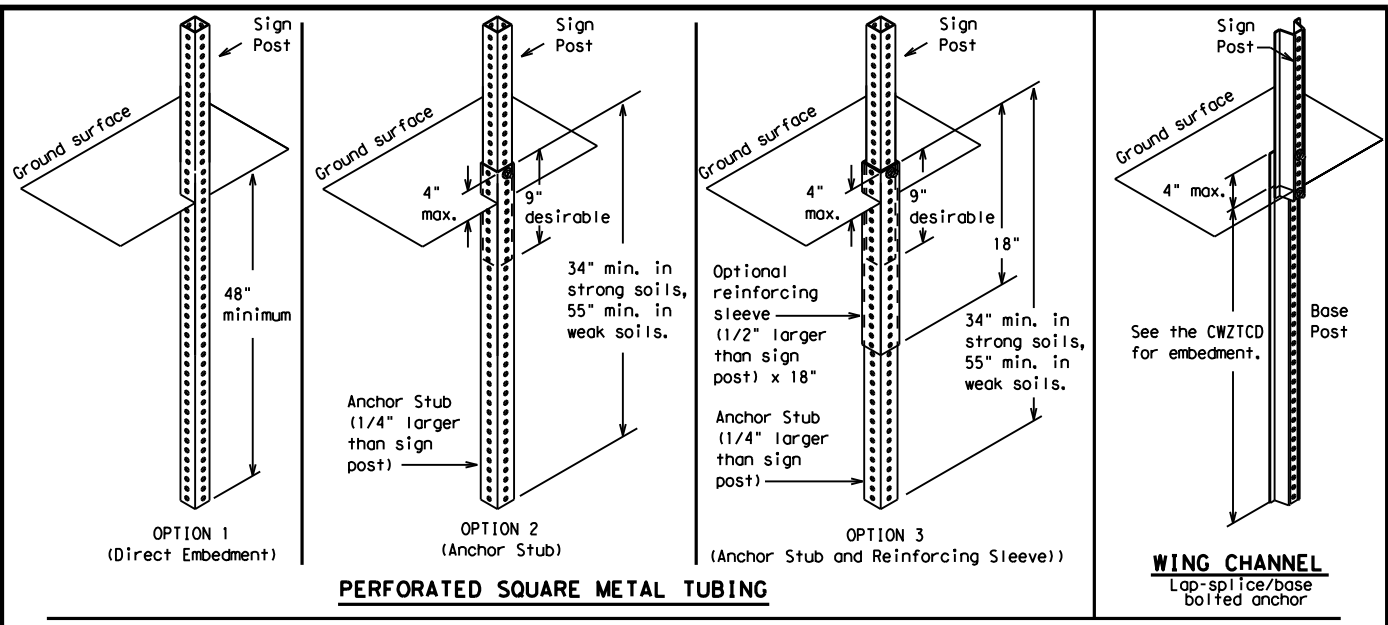
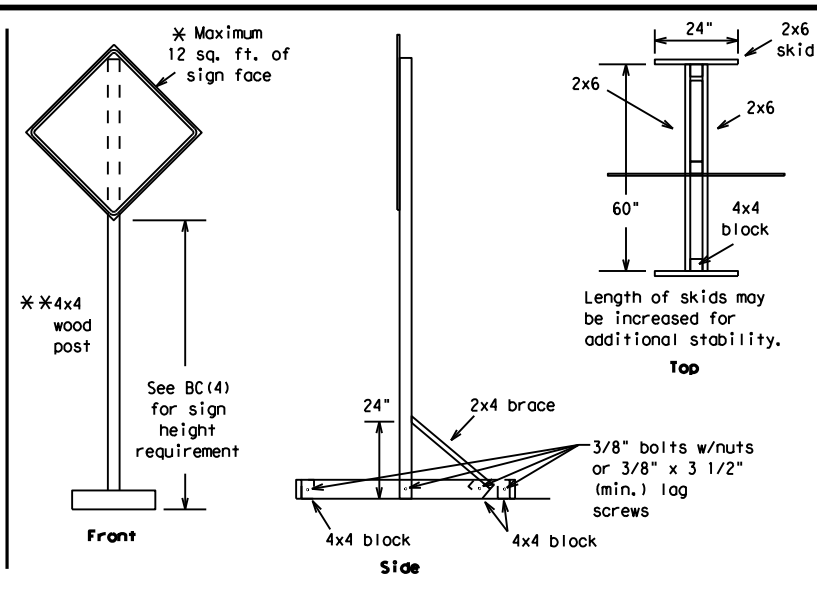

GROUND MOUNTED SIGN SUPPORTS

Refer to the CWZTCD and the manufacturer's installation procedure for each type sign support. The maximum sign square footage shall adhere to the manufacturer's recommendation. Two post installations can be used for larger signs.

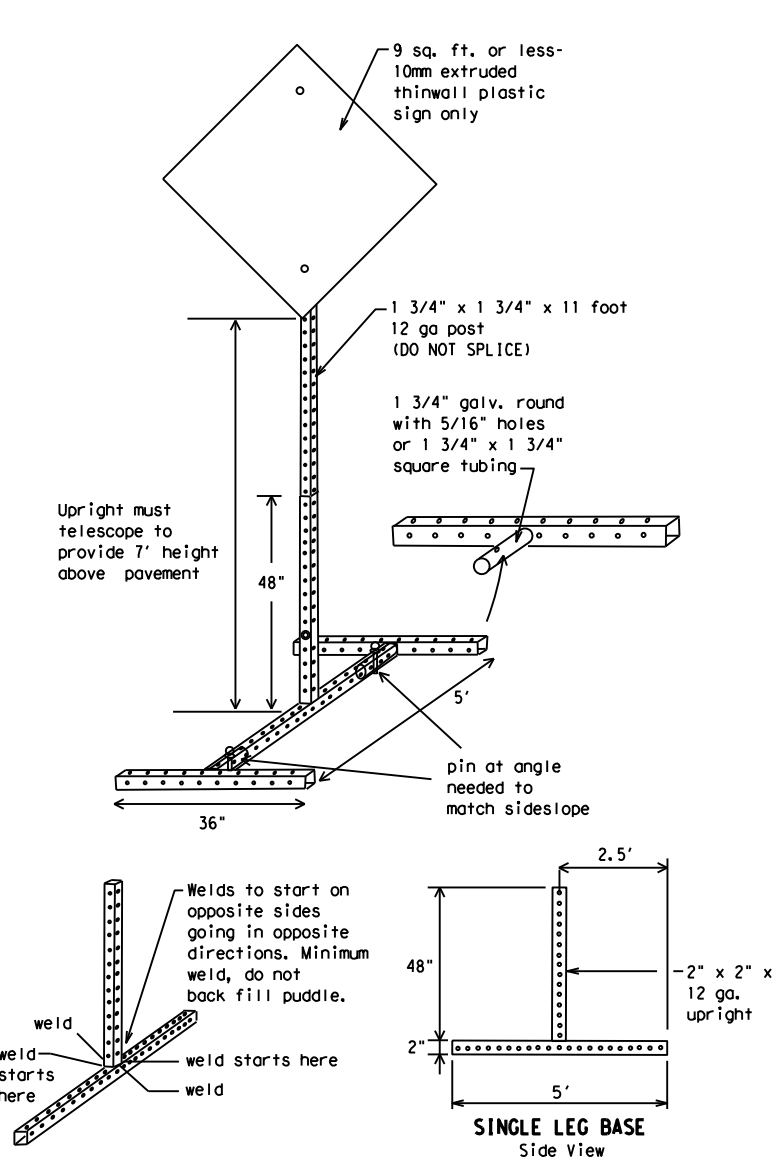

SKID MOUNTED PERFORATED SQUARE STEEL TUBING SIGN SUPPORTS

* LONG/INTERMEDIATE TERM STATIONARY - PORTABLE SKID MOUNTED SIGN SUPPORTS

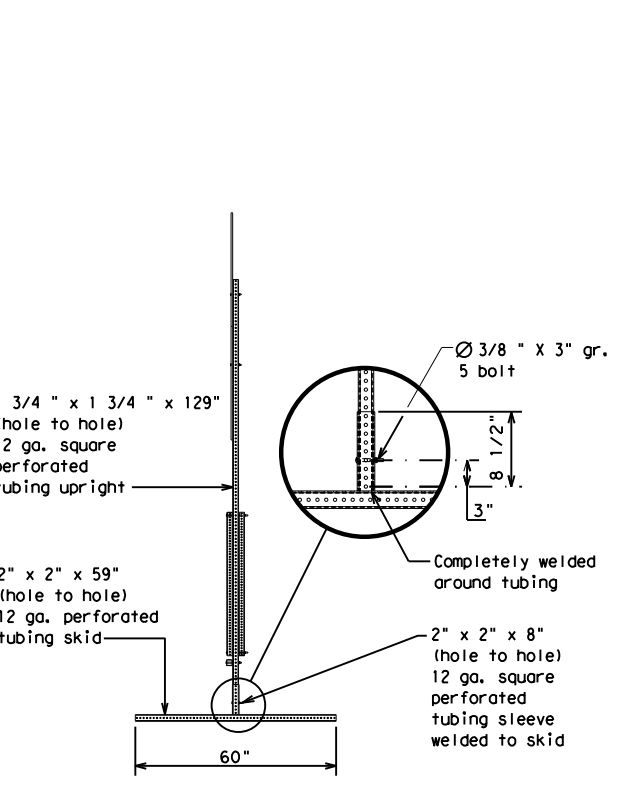
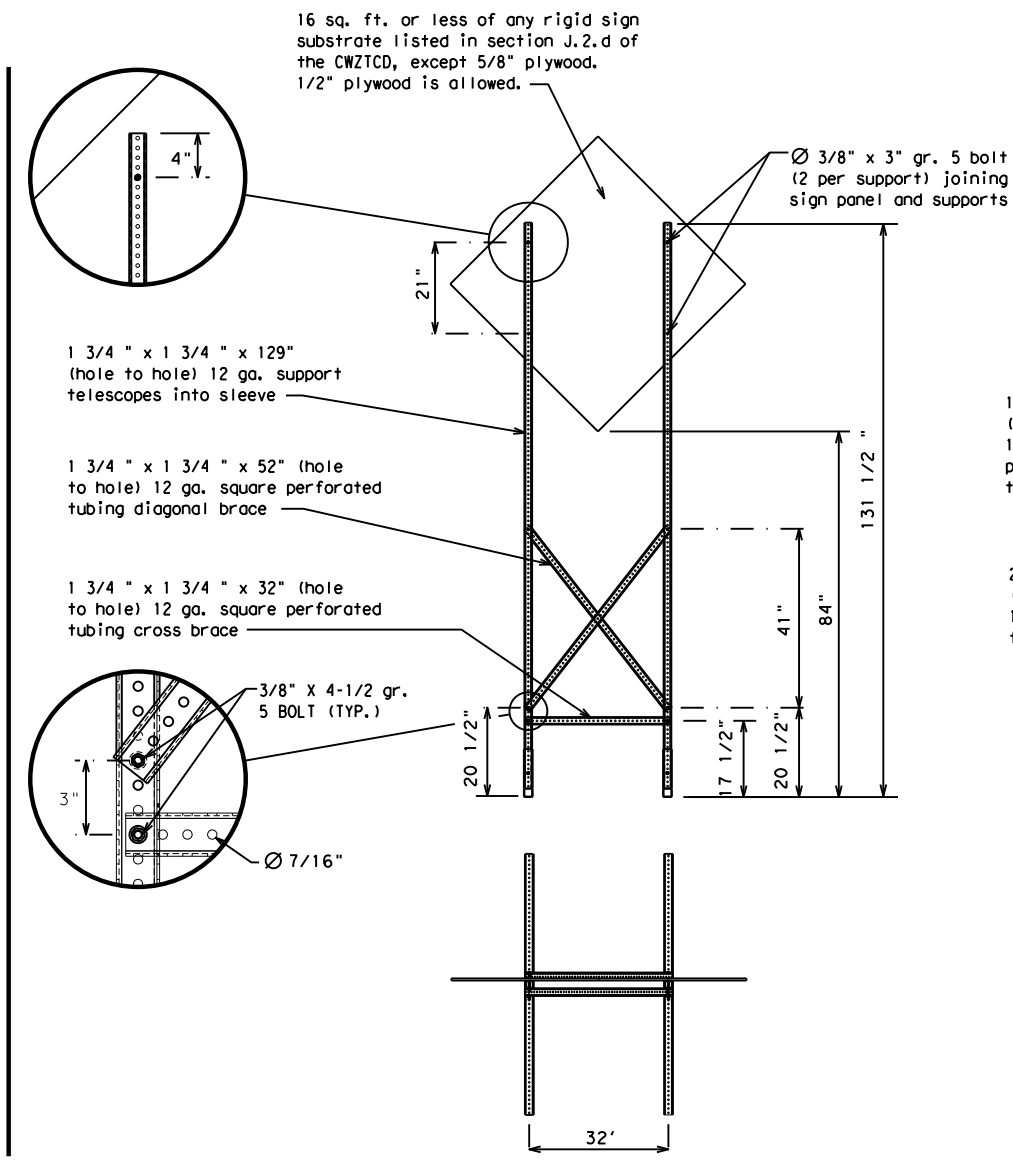

WEDGE ANCHORS
 Both steel and plastic Wedge Anchor Systems as shown on the SMD Standard Sheets may be used as temporary sign supports for signs up to 10 square feet of sign face. They may be set in concrete or in sturdy soils if approved by the Engineer. (See web address for "Traffic Engineering Standard Sheets" on BC(1)).

OTHER DESIGNS
 MORE DETAILS OF APPROVED LONG/INTERMEDIATE AND SHORT TERM SUPPORTS CAN BE FOUND ON THE CWZTCD LIST. SEE BC(1) FOR WEBSITE LOCATION.

- GENERAL NOTES**
- Nails may be used in the assembly of wooden sign supports, but 3/8" bolts with nuts or 3/8" x 3 1/2" lag screws must be used on every joint for final connection.
 - No more than 2 sign posts shall be placed within a 7 ft. circle, except for specific materials noted on the CWZTCD List.
 - When project is completed, all sign supports and foundations shall be removed from the project site. This will be considered subsidiary to Item 502.
- * See BC(4) for definition of "Work Duration."
 ** Wood sign posts MUST be one piece. Splicing will NOT be allowed. Posts shall be painted white.
 See the CWZTCD for the type of sign substrate that can be used for each approved sign support.

BARRICADE AND CONSTRUCTION TYPICAL SIGN SUPPORT
 BC(5) - 21

FILE:	bc-21.dgn	DN:	TxDOT	CK:	TxDOT	DW:	TxDOT	CR:	TxDOT
© TxDOT	November 2002	CONT	SECT	JOB	HIGHWAY				
REVISIONS	0010	08	060	US	67				
9-07	8-14	DIST	COUNTY	SHEET NO.					
7-13	5-21	ATL	MORRIS	18					

WHEN NOT IN USE, REMOVE THE PCMS FROM THE RIGHT-OF-WAY OR PLACE THE PCMS BEHIND BARRIER OR GUARDRAIL WITH SIGN PANEL TURNED PARALLEL TO TRAFFIC

RECOMMENDED PHASES AND FORMATS FOR PCMS MESSAGES DURING ROADWORK ACTIVITIES

(The Engineer may approve other messages not specifically covered here.)

PORTABLE CHANGEABLE MESSAGE SIGNS

- The Engineer/Inspector shall approve all messages used on portable changeable message signs (PCMS).
- Messages on PCMS should contain no more than 8 words (about four to eight characters per word), not including simple words such as "TO," "FOR," "AT," etc.
- Messages should consist of a single phase, or two phases that alternate. Three-phase messages are not allowed. Each phase of the message should convey a single thought, and must be understood by itself.
- Use the word "EXIT" to refer to an exit ramp on a freeway; i.e., "EXIT CLOSED." Do not use the term "RAMP."
- Always use the route or interstate designation (IH, US, SH, FM) along with the number when referring to a roadway.
- When in use, the bottom of a stationary PCMS message panel should be a minimum 7 feet above the roadway, where possible.
- The message term "WEEKEND" should be used only if the work is to start on Saturday morning and end by Sunday evening at midnight. Actual days and hours of work should be displayed on the PCMS if work is to begin on Friday evening and/or continue into Monday morning.
- The Engineer/Inspector may select one of two options which are available for displaying a two-phase message on a PCMS. Each phase may be displayed for either four seconds each or for three seconds each.
- Do not "flash" messages or words included in a message. The message should be steady burn or continuous while displayed.
- Do not present redundant information on a two-phase message; i.e., keeping two lines of the message the same and changing the third line.
- Do not use the word "Danger" in message.
- Do not display the message "LANES SHIFT LEFT" or "LANES SHIFT RIGHT" on a PCMS. Drivers do not understand the message.
- Do not display messages that scroll horizontally or vertically across the face of the sign.
- The following table lists abbreviated words and two-word phrases that are acceptable for use on a PCMS. Both words in a phrase must be displayed together. Words or phrases not on this list should not be abbreviated, unless shown in the TMUTCD.
- PCMS character height should be at least 18 inches for trailer mounted units. They should be visible from at least 1/2 (.5) mile and the text should be legible from at least 600 feet at night and 800 feet in daylight. Truck mounted units must have a character height of 10 inches and must be legible from at least 400 feet.
- Each line of text should be centered on the message board rather than left or right justified.
- If disabled, the PCMS should default to an illegible display that will not alarm motorists and will only be used to alert workers that the PCMS has malfunctioned. A pattern such as a series of horizontal solid bars is appropriate.

Phase 1: Condition Lists

Road/Lane/Ramp Closure List

FREEWAY CLOSED X MILE	FRONTAGE ROAD CLOSED
ROAD CLOSED AT SH XXX	SHOULDER CLOSED XXX FT
ROAD CLSD AT FM XXXX	RIGHT LN CLOSED XXX FT
RIGHT X LANES CLOSED	RIGHT X LANES OPEN
CENTER LANE CLOSED	DAYTIME LANE CLOSURES
NIGHT LANE CLOSURES	I-XX SOUTH EXIT CLOSED
VARIOUS LANES CLOSED	EXIT XXX CLOSED X MILE
EXIT CLOSED	RIGHT LN TO BE CLOSED
MALL DRIVEWAY CLOSED	X LANES CLOSED TUE - FRI
XXXXXXXX BLVD CLOSED	

Other Condition List

ROADWORK XXX FT	ROAD REPAIRS XXXX FT
FLAGGER XXXX FT	LANE NARROWS XXXX FT
RIGHT LN NARROWS XXXX FT	TWO-WAY TRAFFIC XX MILE
MERGING TRAFFIC XXXX FT	CONST TRAFFIC XXX FT
LOOSE GRAVEL XXXX FT	UNEVEN LANES XXXX FT
DETOUR X MILE	ROUGH ROAD XXXX FT
ROADWORK PAST SH XXXX	ROADWORK NEXT FRI-SUN
BUMP XXXX FT	US XXX EXIT X MILES
TRAFFIC SIGNAL XXXX FT	LANES SHIFT *

* LANES SHIFT in Phase 1 must be used with STAY IN LANE in Phase 2.

Phase 2: Possible Component Lists

Action to Take/Effect on Travel List

MERGE RIGHT	FORM X LINES RIGHT
DETOUR NEXT X EXITS	USE XXXXX RD EXIT
USE EXIT XXX	USE EXIT I-XX NORTH
STAY ON US XXX SOUTH	USE I-XX E TO I-XX N
TRUCKS USE US XXX N	WATCH FOR TRUCKS
WATCH FOR TRUCKS	EXPECT DELAYS
EXPECT DELAYS	PREPARE TO STOP
REDUCE SPEED XXX FT	END SHOULDER USE
USE OTHER ROUTES	WATCH FOR WORKERS
STAY IN LANE *	

Location List

AT FM XXXX
BEFORE RAILROAD CROSSING
NEXT X MILES
PAST US XXX EXIT
XXXXXXXX TO XXXXXX
US XXX TO FM XXXX

Warning List

SPEED LIMIT XX MPH
MAXIMUM SPEED XX MPH
MINIMUM SPEED XX MPH
ADVISORY SPEED XX MPH
RIGHT LANE EXIT
USE CAUTION
DRIVE SAFELY
DRIVE WITH CARE

** Advance Notice List

TUE-FRI XX AM-X PM
APR XX-XX X PM-X AM
BEGINS MONDAY
BEGINS MAY XX
MAY X-X XX PM - XX AM
NEXT FRI-SUN
XX AM TO XX PM
NEXT TUE AUG XX
TONIGHT XX PM-XX AM

** See Application Guidelines Note 6.

APPLICATION GUIDELINES

- Only 1 or 2 phases are to be used on a PCMS.
- The 1st phase (or both) should be selected from the "Road/Lane/Ramp Closure List" and the "Other Condition List".
- A 2nd phase can be selected from the "Action to Take/Effect on Travel, Location, General Warning, or Advance Notice Phase Lists".
- A Location Phase is necessary only if a distance or location is not included in the first phase selected.
- If two PCMS are used in sequence, they must be separated by a minimum of 1000 ft. Each PCMS shall be limited to two phases, and should be understandable by themselves.
- For advance notice, when the current date is within seven days of the actual work date, calendar days should be replaced with days of the week. Advance notification should typically be for no more than one week prior to the work.

WORDING ALTERNATIVES

- The words RIGHT, LEFT and ALL can be interchanged as appropriate.
- Roadway designations IH, US, SH, FM and LP can be interchanged as appropriate.
- EAST, WEST, NORTH and SOUTH (or abbreviations E, W, N and S) can be interchanged as appropriate.
- Highway names and numbers replaced as appropriate.
- ROAD, HIGHWAY and FREEWAY can be interchanged as needed.
- AHEAD may be used instead of distances if necessary.
- FT and MI, MILE and MILES interchanged as appropriate.
- AT, BEFORE and PAST interchanged as needed.
- Distances or AHEAD can be eliminated from the message if a location phase is used.

PCMS SIGNS WITHIN THE R.O.W. SHALL BE BEHIND GUARDRAIL OR CONCRETE BARRIER OR SHALL HAVE A MINIMUM OF FOUR (4) PLASTIC DRUMS PLACED PERPENDICULAR TO TRAFFIC ON THE UPSTREAM SIDE OF THE PCMS, WHEN EXPOSED TO ONE DIRECTION OF TRAFFIC. WHEN EXPOSED TO TWO WAY TRAFFIC, THE FOUR DRUMS SHOULD BE PLACED WITH ONE DRUM AT EACH OF THE FOUR CORNERS OF THE UNIT.

FULL MATRIX PCMS SIGNS

- When Full Matrix PCMS signs are used, the character height and legibility/visibility requirements shall be maintained as listed in Note 15 under "PORTABLE CHANGEABLE MESSAGE SIGNS" above.
- When symbol signs, such as the "Flagger Symbol" (CW20-7) are represented graphically on the Full Matrix PCMS sign and, with the approval of the Engineer, it shall maintain the legibility/visibility requirement listed above.
- When symbol signs are represented graphically on the Full Matrix PCMS, they shall only supplement the use of the static sign represented, and shall not substitute for, or replace that sign.
- A full matrix PCMS may be used to simulate a flashing arrow board provided it meets the visibility, flash rate and dimming requirements on BC(7), for the same size arrow.

DISCLAIMER: The use of this standard is governed by the "Texas Engineering Practice Act". No warranty of any kind is made by TxDOT for any purpose whatsoever. TxDOT assumes no responsibility for the conversion of this standard to other formats for use in other projects. Project: May 2024 standards-bc-31 (1).dgn

DATE: 1/11/2024 2:00:34 PM
FILE: T:\Engdata\Traffic\DGN\192515_Jamie\JOBS\LIGHTING PROJECTS\Lighting Project

WORD OR PHRASE	ABBREVIATION	WORD OR PHRASE	ABBREVIATION
Access Road	ACCS RD	Major	MAJ
Alternate	ALT	Miles	MI
Avenue	AVE	Miles Per Hour	MPH
Best Route	BEST RTE	Minor	MNR
Boulevard	BLVD	Monday	MON
Bridge	BRDG	Normal	NORM
Cannot	CANT	North	N
Center	CTR	Northbound	(route) N
Construction Ahead	CONST AHD	Parking	PKING
CROSSING	XING	Road	RD
Detour Route	DETOUR RTE	Right Lane	RT LN
Do Not	DONT	Saturday	SAT
East	E	Service Road	SERV RD
Eastbound	(route) E	Shoulder	SHLDR
Emergency	EMER	Slippery	SLIP
Emergency Vehicle	EMER VEH	South	S
Entrance, Enter	ENT	Southbound	(route) S
Express Lane	EXP LN	Speed	SPD
Expressway	EXPWY	Street	ST
XXXX Feet	XXXX FT	Sunday	SUN
Fog Ahead	FOG AHD	Telephone	PHONE
Freeway	FRWY, FWY	Temporary	TEMP
Freeway Blocked	FWY BLKD	Thursday	THURS
Friday	FRI	To Downtown	TO DWNTN
Hazardous Driving	HAZ DRIVING	Traffic	TRAF
Hazardous Material	HAZMAT	Travelers	TRVLR
High-Occupancy Vehicle	HOV	Tuesday	TUES
Hour(s)	HR, HRS	Time Minutes	TIME MIN
Information	INFO	Upper Level	UPR LEVEL
It Is	ITS	Vehicles (s)	VEH, VEHS
Junction	JCT	Warning	WARN
Left	LFT	Wednesday	WED
Left Lane	LFT LN	Weight Limit	WT LIMIT
Lane Closed	LN CLOSED	West	W
Lower Level	LWR LEVEL	Westbound	(route) W
Maintenance	MAINT	Wet Pavement	WET PVMT
		Will Not	WONT

Roadway designation # IH-number, US-number, SH-number, FM-number

<h3>BARRICADE AND CONSTRUCTION PORTABLE CHANGEABLE MESSAGE SIGN (PCMS)</h3>			
<h2>BC (6) - 21</h2>			
FILE:	bc-21.dgn	DW:	TxDOT
CONT:	NOVEMBER 2002	SECT:	JOB
REVISIONS:	0010 08	DIST:	COUNTY
9-07 8-14		ATL:	MORRIS
7-13 5-21		SHEET NO.:	19

DISCLAIMER: The use of this standard is governed by the "Texas Engineering Practice Act". No warranty of any kind is made by TxDOT for any purpose whatsoever. TxDOT assumes no responsibility for the conversion of this standard to other formats or for incorrect results or damages resulting from its use.

DATE: 1/11/2024 2:01:07 PM
 FILE: I:\Engdat\Traffic\DGND\192515_Jamie\JOBS\LIGHTING PROJECTS\Lighting Project May 2024\standards\bc-21 (1).dgn

- Barrier Reflectors shall be pre-qualified, and conform to the color and reflectivity requirements of DMS-8600. A list of prequalified Barrier Reflectors can be found at the Material Producer List web address shown on BC(1).
- Color of Barrier Reflectors shall be as specified in the TMUTCD. The cost of the reflectors shall be considered subsidiary to Item 512.

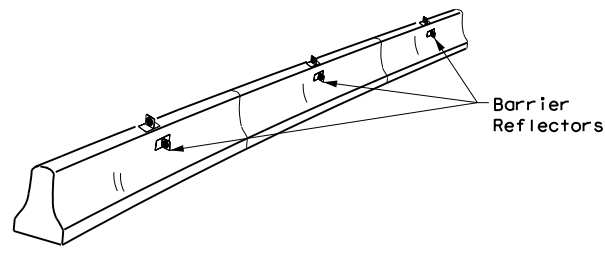

CONCRETE TRAFFIC BARRIER (CTB)

- Where traffic is on one side of the CTB, two (2) Barrier Reflectors shall be mounted in approximately the midsection of each section of CTB. An alternate mounting location is uniformly spaced at one end of each CTB. This will allow for attachment of a barrier grapple without damaging the reflector. The Barrier Reflector mounted on the side of the CTB shall be located directly below the reflector mounted on top of the barrier, as shown in the detail above.
- Where CTB separates two-way traffic, three barrier reflectors shall be mounted on each section of CTB. The reflector unit on top shall have two yellow reflective faces (Bi-Directional) while the reflectors on each side of the barrier shall have one yellow reflective face, as shown in the detail above.
- When CTB separates traffic traveling in the same direction, no barrier reflectors will be required on top of the CTB.
- Barrier Reflector units shall be yellow or white in color to match the edgeline being supplemented.
- Maximum spacing of Barrier Reflectors is forty (40) feet.
- Pavement markers or temporary flexible-reflective roadway marker tabs shall NOT be used as CTB delineation.
- Attachment of Barrier Reflectors to CTB shall be per manufacturer's recommendations.
- Missing or damaged Barrier Reflectors shall be replaced as directed by the Engineer.
- Single slope barriers shall be delineated as shown on the above detail.

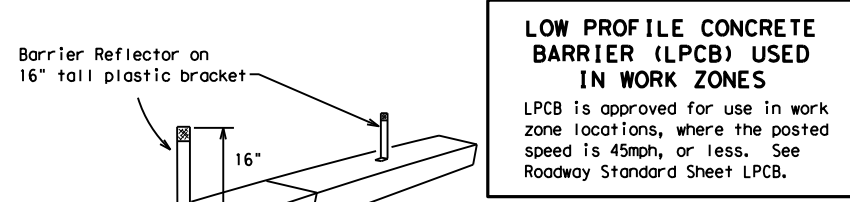

LOW PROFILE CONCRETE BARRIER (LPCB) USED IN WORK ZONES
 LPCB is approved for use in work zone locations, where the posted speed is 45mph, or less. See Roadway Standard Sheet LPCB.

LOW PROFILE CONCRETE BARRIER (LPCB)

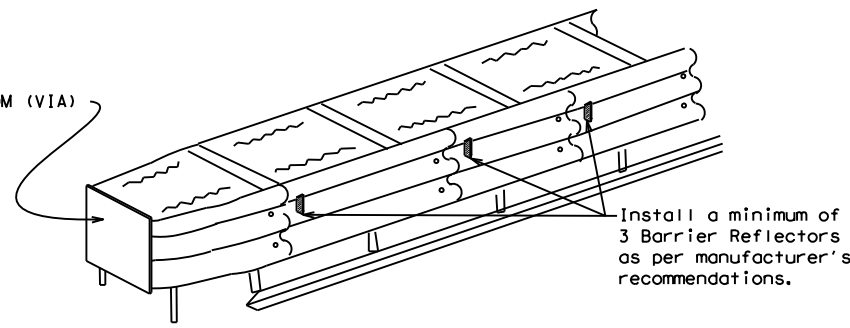

DELINEATION OF END TREATMENTS

END TREATMENTS FOR CTB'S USED IN WORK ZONES
 End treatments used on CTB's in work zones shall meet the appropriate crashworthy standards as defined in the Manual for Assessing Safety Hardware (MASH). Refer to the CWZTCD List for approved end treatments and manufacturers.

BARRIER REFLECTORS FOR CONCRETE TRAFFIC BARRIER AND ATTENUATORS

WARNING LIGHTS

- Warning lights shall meet the requirements of the TMUTCD.
- Warning lights shall NOT be installed on barricades.
- Type A-Low Intensity Flashing Warning Lights are commonly used with drums. They are intended to warn of or mark a potentially hazardous area. Their use shall be as indicated on this sheet and/or other sheets of the plans by the designation "FL". The Type A Warning Lights shall not be used with signs manufactured with Type B_{FL} or C_{FL} Sheeting meeting the requirements of Departmental Material Specification DMS-8300.
- Type-C and Type D 360 degree Steady Burn Lights are intended to be used in a series for delineation to supplement other traffic control devices. Their use shall be as indicated on this sheet and/or other sheets of the plans by the designation "SB".
- The Engineer/Inspector or the plans shall specify the location and type of warning lights to be installed on the traffic control devices.
- When required by the Engineer, the Contractor shall furnish a copy of the warning lights certification. The warning light manufacturer will certify the warning lights meet the requirements of the latest ITE Purchase Specifications for Flashing and Steady-Burn Warning Lights.
- When used to delineate curves, Type-C and Type D Steady Burn Lights should only be placed on the outside of the curve, not the inside.
- The location of warning lights and warning reflectors on drums shall be as shown elsewhere in the plans.

WARNING LIGHTS MOUNTED ON PLASTIC DRUMS

- Type A flashing warning lights are intended to warn drivers that they are approaching or are in a potentially hazardous area.
- Type A random flashing warning lights are not intended for delineation and shall not be used in a series.
- A series of sequential flashing warning lights placed on channelizing devices to form a merging taper may be used for delineation. If used, the successive flashing of the sequential warning lights should occur from the beginning of the taper to the end of the merging taper in order to identify the desired vehicle path. The rate of flashing for each light shall be 65 flashes per minute, plus or minus 10 flashes.
- Type C and D steady-burn warning lights are intended to be used in a series to delineate the edge of the travel lane on detours, on lane changes, on lane closures, and on other similar conditions.
- Type A, Type C and Type D warning lights shall be installed at locations as detailed on other sheets in the plans.
- Warning lights shall not be installed on a drum that has a sign, chevron or vertical panel.
- The maximum spacing for warning lights on drums should be identical to the channelizing device spacing.

WARNING REFLECTORS MOUNTED ON PLASTIC DRUMS AS A SUBSTITUTE FOR TYPE C (STEADY BURN) WARNING LIGHTS

- A warning reflector or approved substitute may be mounted on a plastic drum as a substitute for a Type C, steady burn warning light at the discretion of the Contractor unless otherwise noted in the plans.
- The warning reflector shall be yellow in color and shall be manufactured using a sign substrate approved for use with plastic drums listed on the CWZTCD.
- The warning reflector shall have a minimum retroreflective surface area (one-side) of 30 square inches.
- Round reflectors shall be fully reflectorized, including the area where attached to the drum.
- Square substrates must have a minimum of 30 square inches of reflectorized sheeting. They do not have to be reflectorized where it attaches to the drum.
- The side of the warning reflector facing approaching traffic shall have sheeting meeting the color and retroreflectivity requirements for DMS 8300-Type B or Type C.
- When used near two-way traffic, both sides of the warning reflector shall be reflectorized.
- The warning reflector should be mounted on the side of the handle nearest approaching traffic.
- The maximum spacing for warning reflectors should be identical to the channelizing device spacing requirements.

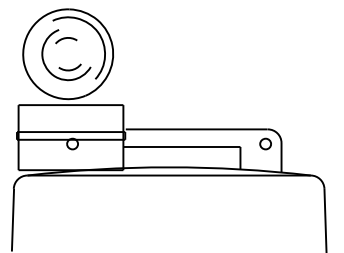

Type C Warning Light or approved substitute mounted on a drum adjacent to the travel way.

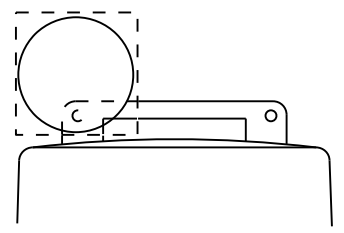

Warning reflector may be round or square. Must have a yellow reflective surface area of at least 30 square inches

Arrow Boards may be located behind channelizing devices in place for a shoulder taper or merging taper, otherwise they shall be delineated with four (4) channelizing devices placed perpendicular to traffic on the upstream side of traffic.

- The Flashing Arrow Board should be used for all lane closures on multi-lane roadways, or slow moving maintenance or construction activities on the travel lanes.
- Flashing Arrow Boards should not be used on two-lane, two-way roadways, detours, diversions or work on shoulders unless the "CAUTION" display (see detail below) is used.
- The Engineer/Inspector shall choose all appropriate signs, barricades and/or other traffic control devices that should be used in conjunction with the Flashing Arrow Board.
- The Flashing Arrow Board should be able to display the following symbols:

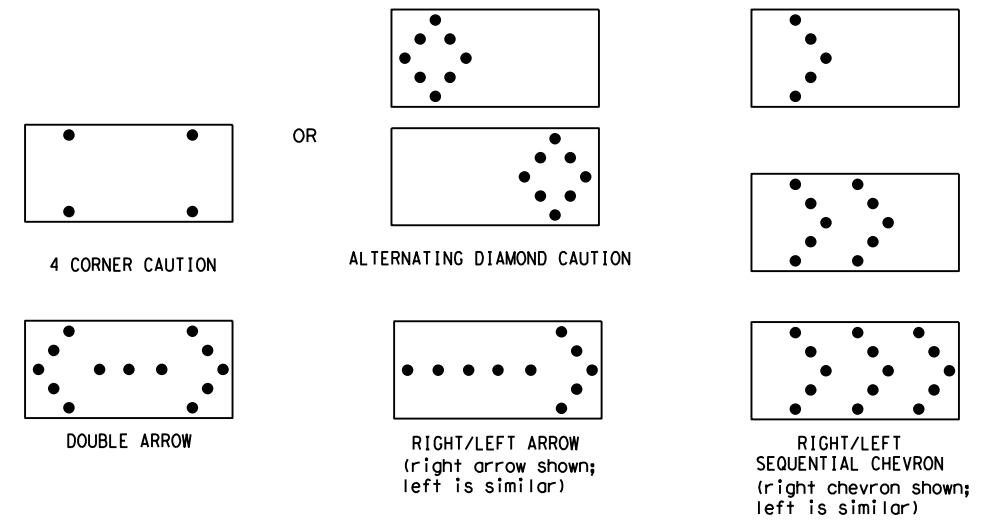

- The "CAUTION" display consists of four corner lamps flashing simultaneously, or the Alternating Diamond Caution mode as shown.
- The straight line caution display is NOT ALLOWED.
- The Flashing Arrow Board shall be capable of minimum 50 percent dimming from rated lamp voltage. The flashing rate of the lamps shall not be less than 25 nor more than 40 flashes per minute.
- Minimum lamp "on time" shall be approximately 50 percent for the flashing arrow and equal intervals of 25 percent for each sequential phase of the flashing chevron.
- The sequential arrow display is NOT ALLOWED.
- The flashing arrow display is the TxDOT standard; however, the sequential chevron display may be used during daylight operations.
- The Flashing Arrow Board shall be mounted on a vehicle, trailer or other suitable support.
- A Flashing Arrow Board SHALL NOT BE USED to laterally shift traffic.
- A full matrix PCMS may be used to simulate a Flashing Arrow Board provided it meets visibility, flash rate and dimming requirements on this sheet for the same size arrow.
- Minimum mounting height of trailer mounted Arrow Boards should be 7 feet from roadway to bottom of panel.

REQUIREMENTS			
TYPE	MINIMUM SIZE	MINIMUM NUMBER OF PANEL LAMPS	MINIMUM VISIBILITY DISTANCE
B	30 x 60	13	3/4 mile
C	48 x 96	15	1 mile

ATTENTION
 Flashing Arrow Boards shall be equipped with automatic dimming devices.

WHEN NOT IN USE, REMOVE THE ARROW BOARD FROM THE RIGHT-OF-WAY OR PLACE THE ARROW BOARD BEHIND CONCRETE TRAFFIC BARRIER OR GUARDRAIL.

FLASHING ARROW BOARDS

SHEET 7 OF 12

TRUCK-MOUNTED ATTENUATORS

- Truck-mounted attenuators (TMA) used on TxDOT facilities must meet the requirements outlined in the Manual for Assessing Safety Hardware (MASH).
- Refer to the CWZTCD for the requirements of Level 2 or Level 3 TMAs.
- Refer to the CWZTCD for a list of approved TMAs.
- TMAs are required on freeways unless otherwise noted in the plans.
- A TMA should be used anytime that it can be positioned 30 to 100 feet in advance of the area of crew exposure without adversely affecting the work performance.
- The only reason a TMA should not be required is when a work area is spread down the roadway and the work crew is an extended distance from the TMA.



BARRICADE AND CONSTRUCTION ARROW PANEL, REFLECTORS, WARNING LIGHTS & ATTENUATOR

BC (7) -21

FILE:	bc-21.dgn	DN:	TxDOT	CR:	TxDOT	OW:	TxDOT	CK:	TxDOT
© TxDOT	November 2002	CONT	SECT	JOB	HIGHWAY				
REVISIONS		0010	08	060	US 67				
9-07	8-14	DIST	COUNTY	SHEET NO.					
7-13	5-21	ATL	MORRIS	20					

DISCLAIMER: The use of this standard is governed by the "Texas Engineering Practice Act". No warranty of any kind is made by TxDOT for any purpose whatsoever. TxDOT assumes no responsibility for the conversion of this standard to other formats or for incorrect results or damages resulting from its use.
 DATE: 1/11/2024 2:01:46 PM
 FILE: T:\Engdata\Traffic\DGND\192515_Jamie\JOBS\LIGHTING PROJECTS\Lighting Project May 2024\standards\bc-21 (1).dgn

GENERAL NOTES

- For long term stationary work zones on freeways, drums shall be used as the primary channelizing device.
- For intermediate term stationary work zones on freeways, drums should be used as the primary channelizing device but may be replaced in tangent sections by vertical panels, or 42" two-piece cones. In tangent sections, one-piece cones may be used with the approval of the Engineer but only if personnel are present on the project at all times to maintain the cones in proper position and location.
- For short term stationary work zones on freeways, drums are the preferred channelizing device but may be replaced in tapers, transitions and tangent sections by vertical panels, two-piece cones or one-piece cones as approved by the Engineer.
- Drums and all related items shall comply with the requirements of the current version of the "Texas Manual on Uniform Traffic Control Devices" (TMUTCD) and the "Compliant Work Zone Traffic Control Devices List" (CWZTCD).
- Drums, bases, and related materials shall exhibit good workmanship and shall be free from objectionable marks or defects that would adversely affect their appearance or serviceability.
- The Contractor shall have a maximum of 24 hours to replace any plastic drums identified for replacement by the Engineer/Inspector. The replacement device must be an approved device.

GENERAL DESIGN REQUIREMENTS

- Pre-qualified plastic drums shall meet the following requirements:
- Plastic drums shall be a two-piece design; the "body" of the drum shall be the top portion and the "base" shall be the bottom.
 - The body and base shall lock together in such a manner that the body separates from the base when impacted by a vehicle traveling at a speed of 20 MPH or greater but prevents accidental separation due to normal handling and/or air turbulence created by passing vehicles.
 - Plastic drums shall be constructed of lightweight flexible, and deformable materials. The Contractor shall NOT use metal drums or single piece plastic drums as channelization devices or sign supports.
 - Drums shall present a profile that is a minimum of 18 inches in width at the 36 inch height when viewed from any direction. The height of drum unit (body installed on base) shall be a minimum of 36 inches and a maximum of 42 inches.
 - The top of the drum shall have a built-in handle for easy pickup and shall be designed to drain water and not collect debris. The handle shall have a minimum of two widely spaced 9/16 inch diameter holes to allow attachment of a warning light, warning reflector unit or approved compliant sign.
 - The exterior of the drum body shall have a minimum of four alternating orange and white retroreflective circumferential stripes not less than 4 inches nor greater than 8 inches in width. Any non-reflectorized space between any two adjacent stripes shall not exceed 2 inches in width.
 - Bases shall have a maximum width of 36 inches, a maximum height of 4 inches, and a minimum of two footholds of sufficient size to allow base to be held down while separating the drum body from the base.
 - Plastic drums shall be constructed of ultra-violet stabilized, orange, high-density polyethylene (HDPE) or other approved material.
 - Drum body shall have a maximum unballasted weight of 11 lbs.
 - Drum and base shall be marked with manufacturer's name and model number.

RETROREFLECTIVE SHEETING

- The stripes used on drums shall be constructed of sheeting meeting the color and retroreflectivity requirements of Departmental Materials Specification DMS-8300, "Sign Face Materials." Type A or Type B reflective sheeting shall be supplied unless otherwise specified in the plans.
- The sheeting shall be suitable for use on and shall adhere to the drum surface such that, upon vehicular impact, the sheeting shall remain adhered in-place and exhibit no delaminating, cracking, or loss of retroreflectivity other than that loss due to abrasion of the sheeting surface.

BALLAST

- Unballasted bases shall be large enough to hold up to 50 lbs. of sand. This base, when filled with the ballast material, should weigh between 35 lbs (minimum) and 50 lbs (maximum). The ballast may be sand in one to three sandbags separate from the base, sand in a sand-filled plastic base, or other ballasting devices as approved by the Engineer. Stacking of sandbags will be allowed, however height of sandbags above pavement surface may not exceed 12 inches.
- Bases with built-in ballast shall weigh between 40 lbs. and 50 lbs. Built-in ballast can be constructed of an integral crumb rubber base or a solid rubber base.
- Recycled truck tire sidewalls may be used for ballast on drums approved for this type of ballast on the CWZTCD list.
- The ballast shall not be heavy objects, water, or any material that would become hazardous to motorists, pedestrians, or workers when the drum is struck by a vehicle.
- When used in regions susceptible to freezing, drums shall have drainage holes in the bottoms so that water will not collect and freeze becoming a hazard when struck by a vehicle.
- Ballast shall not be placed on top of drums.
- Adhesives may be used to secure base of drums to pavement.

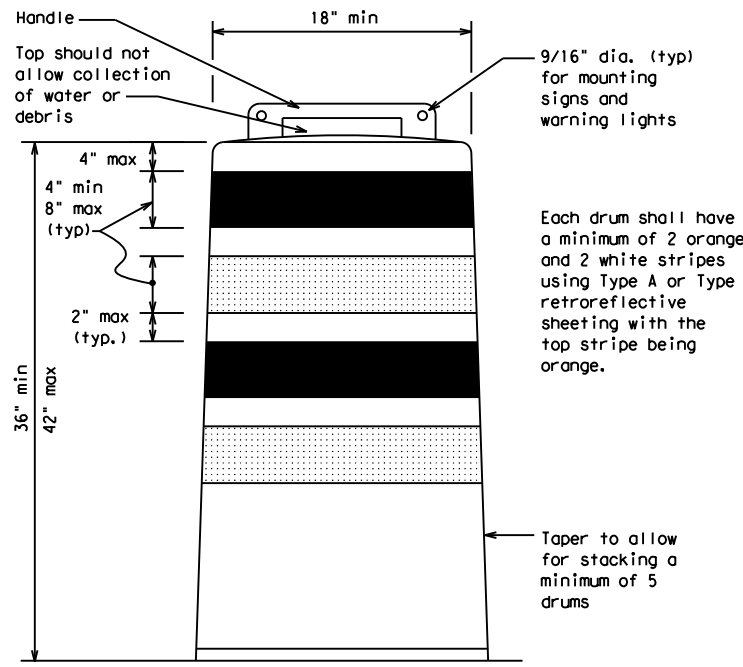

Each drum shall have a minimum of 2 orange and 2 white stripes using Type A or Type B retroreflective sheeting with the top stripe being orange.

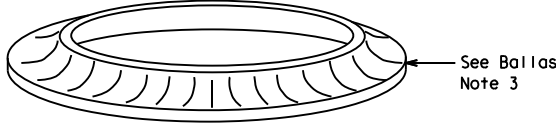

See Ballast Note 3

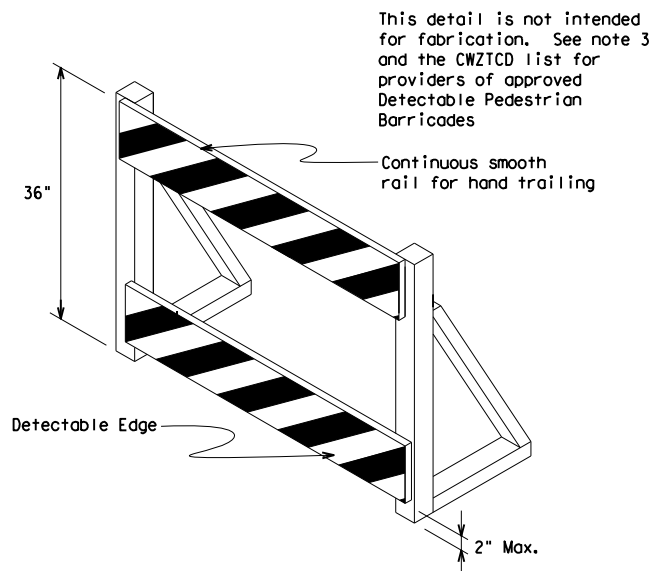

This detail is not intended for fabrication. See note 3 and the CWZTCD list for providers of approved Detectable Pedestrian Barricades

DETECTABLE PEDESTRIAN BARRICADES

- When existing pedestrian facilities are disrupted, closed, or relocated in a TTC zone, the temporary facilities shall be detectable and include accessibility features consistent with the features present in the existing pedestrian facility. Refer to WZ(BTS-2) for Pedestrian Control requirements for Sidewalk Diversions, Sidewalk Detours and Crosswalk Closures.
- Where pedestrians with visual disabilities normally use the closed sidewalk, a Detectable Pedestrian Barricade shall be placed across the full width of the closed sidewalk instead of a Type 3 Barricade.
- Detectable pedestrian barricades similar to the one pictured above, longitudinal channelizing devices, some concrete barriers, and wood or chain link fencing with a continuous detectable edging can satisfactorily delineate a pedestrian path.
- Tape, rope, or plastic chain strung between devices are not detectable, do not comply with the design standards in the "Americans with Disabilities Act Accessibility Guidelines (ADAAG)" and should not be used as a control for pedestrian movements.
- Warning lights shall not be attached to detectable pedestrian barricades.
- Detectable pedestrian barricades should use 8" nominal barricade rails as shown on BC(10) provided that the top rail provides a smooth continuous rail suitable for hand trailing with no splinters, burrs, or sharp edges.

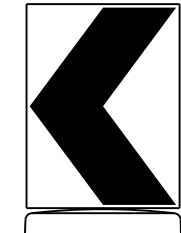

18" x 24" Sign
(Maximum Sign Dimension)
Chevron CW1-8, Opposing Traffic Lane Divider, Driveway sign D70a, Keep Right R4 series or other signs as approved by Engineer

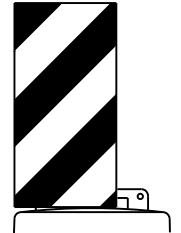

12" x 24" Vertical Panel
mount with diagonals sloping down towards travel way

Plywood, Aluminum or Metal sign substrates shall NOT be used on plastic drums

SIGNS, CHEVRONS, AND VERTICAL PANELS MOUNTED ON PLASTIC DRUMS

- Signs used on plastic drums shall be manufactured using substrates listed on the CWZTCD.
- Chevrons and other work zone signs with an orange background shall be manufactured with Type B_{FL} or Type C_{FL} Orange sheeting meeting the color and retroreflectivity requirements of DMS-8300, "Sign Face Material," unless otherwise specified in the plans.
- Vertical Panels shall be manufactured with orange and white sheeting meeting the requirements of DMS-8300 Type A or Type B. Diagonal stripes on Vertical Panels shall slope down toward the intended traveled lane.
- Other sign messages (text or symbolic) may be used as approved by the Engineer. Sign dimensions shall not exceed 18 inches in width or 24 inches in height, except for the R9 series signs discussed in note 8 below.
- Signs shall be installed using a 1/2 inch bolt (nominal) and nut, two washers, and one locking washer for each connection.
- Mounting bolts and nuts shall be fully engaged and adequately torqued. Bolts should not extend more than 1/2 inch beyond nuts.
- Chevrons may be placed on drums on the outside of curves, on merging tapers or on shifting tapers. When used in these locations, they may be placed on every drum or spaced not more than on every third drum. A minimum of three (3) should be used at each location called for in the plans.
- R9-9, R9-10, R9-11 and R9-11a Sidewalk Closed signs which are 24 inches wide may be mounted on plastic drums, with approval of the Engineer.

SHEET 8 OF 12



BARRICADE AND CONSTRUCTION CHANNELIZING DEVICES

BC (8) - 21

FILE:	bc-21.dgn	DN:	TxDOT	CR:	TxDOT	OW:	TxDOT	CK:	TxDOT
© TxDOT	November 2002	CONT	SECT	JOB	HIGHWAY				
REVISIONS		0010	08	060	US 67				
4-03	8-14	DIST	COUNTY	SHEET NO.					
9-07	5-21	ATL	MORRIS	21					
7-13									

DISCLAIMER: The use of this standard is governed by the "Texas Engineering Practice Act". No warranty of any kind is made by TxDOT for any purpose whatsoever. TxDOT assumes no responsibility for the conversion of this standard to other formats or for incorrect results or damages resulting from its use.

DATE: 1/11/2024 2:02:12 PM
 FILE: I:\engdata\Traffic\DGND\192515_Jamie\JOBS\LIGHTING PROJECTS\Lighting Project May 2024\standards\bc-21 (1).dgn

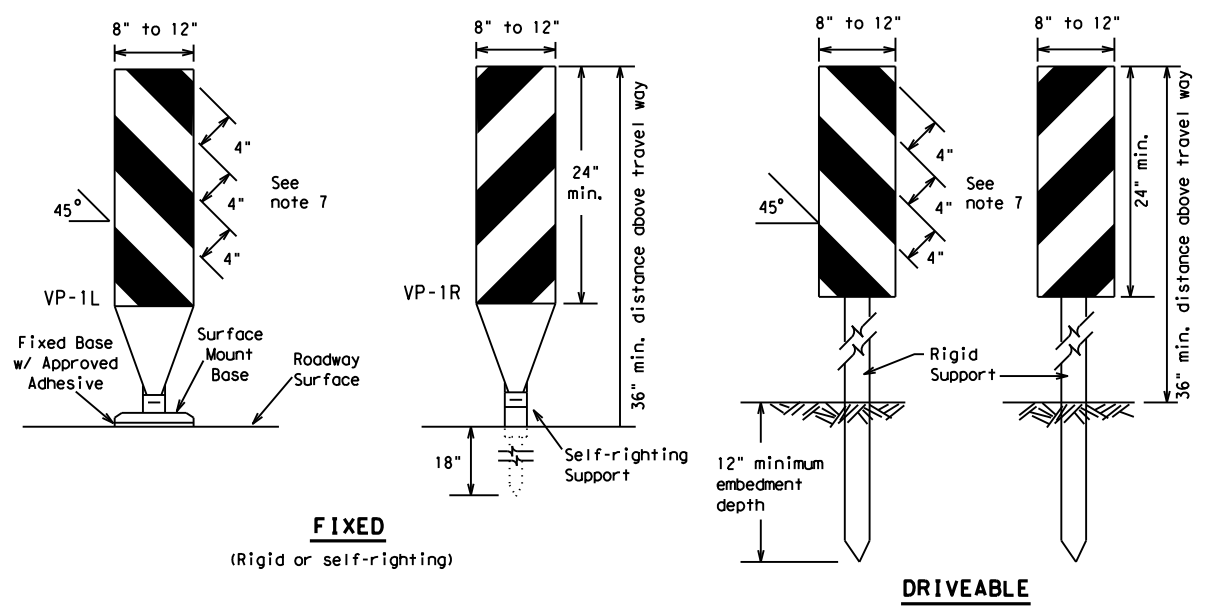

FIXED
(Rigid or self-righting)

DRIVEABLE

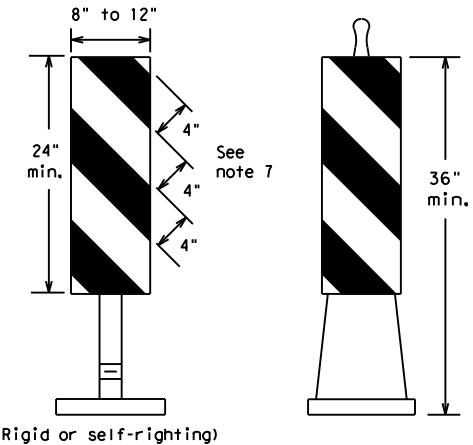

PORTABLE

VERTICAL PANELS (VPs)

- Vertical Panels (VP's) are normally used to channelize traffic or divide opposing lanes of traffic.
- VP's may be used in daytime or nighttime situations. They may be used at the edge of shoulder drop-offs and other areas such as lane transitions where positive daytime and nighttime delineation is required. The Engineer/Inspector shall refer to the Roadway Design Manual for additional requirements on the use VP's for drop-offs.
- VP's should be mounted back to back if used at the edge of cuts adjacent to two-way two lane roadways. Stripes are to be reflective orange and reflective white and should always slope downward toward the travel lane.
- VP's used on expressways and freeways or other high speed roadways, may have more than 270 square inches of retroreflective area facing traffic.
- Self-righting supports are available with portable base. See "Compliant Work Zone Traffic Control Devices List" (CWZTCD).
- Sheeting for the VP's shall be retroreflective Type A or Type B conforming to Departmental Material Specification DMS-8300, unless noted otherwise.
- Where the height of reflective material on the vertical panel is 36 inches or greater, a panel stripe of 6 inches shall be used.

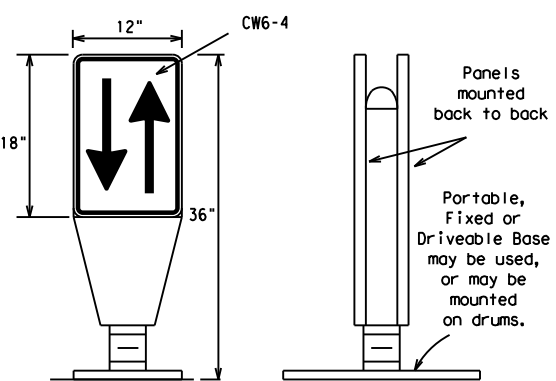

OPPOSING TRAFFIC LANE DIVIDERS (OTLD)

- Opposing Traffic Lane Dividers (OTLD) are delineation devices designed to convert a normal one-way roadway section to two-way operation. OTLD's are used on temporary centerlines. The upward and downward arrows on the sign's face indicate the direction of traffic on either side of the divider. The base is secured to the pavement with an adhesive or rubber weight to minimize movement caused by a vehicle impact or wind gust.
- The OTLD may be used in combination with 42" cones or VPs.
- Spacing between the OTLD shall not exceed 500 feet. 42" cones or VPs placed between the OTLD's should not exceed 100 foot spacing.
- The OTLD shall be orange with a black non-reflective legend. Sheeting for the OTLD shall be retroreflective Type B_{FL} or Type C_{FL} conforming to Departmental Material Specification DMS-8300, unless noted otherwise. The legend shall meet the requirements of DMS-8300.

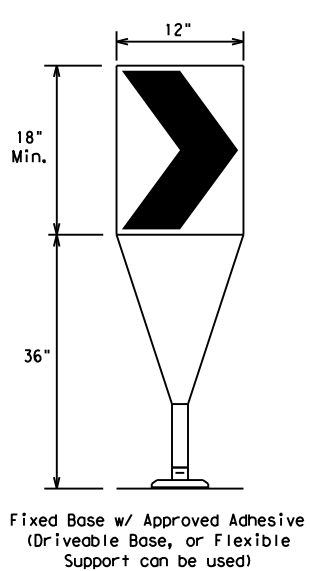

- The chevron shall be a vertical rectangle with a minimum size of 12 by 18 inches.
- Chevrons are intended to give notice of a sharp change of alignment with the direction of travel and provide additional emphasis and guidance for vehicle operators with regard to changes in horizontal alignment of the roadway.
- Chevrons, when used, shall be erected on the outside of a sharp curve or turn, or on the far side of an intersection. They shall be in line with and at right angles to approaching traffic. Spacing should be such that the motorist always has three in view, until the change in alignment eliminates its need.
- To be effective, the chevron should be visible for at least 500 feet.
- Chevrons shall be orange with a black nonreflective legend. Sheeting for the chevron shall be retroreflective Type B_{FL} or Type C_{FL} conforming to Departmental Material Specification DMS-8300, unless noted otherwise. The legend shall meet the requirements of DMS-8300.
- For Long Term Stationary use on tapers or transitions on freeways and divided highways, self-righting chevrons may be used to supplement plastic drums but not to replace plastic drums.

CHEVRONS

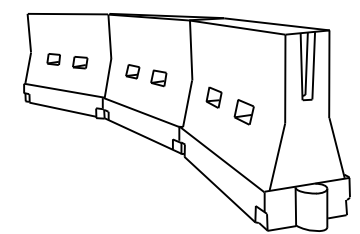

LONGITUDINAL CHANNELIZING DEVICES (LCD)

- LCDs are crashworthy, lightweight, deformable devices that are highly visible, have good target value and can be connected together. They are not designed to contain or redirect a vehicle on impact.
- LCDs may be used instead of a line of cones or drums.
- LCDs shall be placed in accordance to application and installation requirements specific to the device, and used only when shown on the CWZTCD list.
- LCDs should not be used to provide positive protection for obstacles, pedestrians or workers.
- LCDs shall be supplemented with retroreflective delineation as required for temporary barriers on BC(7) when placed roughly parallel to the travel lanes.
- LCDs used as barricades placed perpendicular to traffic should have at least one row of reflective sheeting meeting the requirements for barricade rails as shown on BC(10). Place reflective sheeting near the top of the LCD along the full length of the device.

WATER BALLASTED SYSTEMS USED AS BARRIERS

- Water ballasted systems used as barriers shall not be used solely to channelize road users, but also to protect the work space per the appropriate Manual for Assessing Safety Hardware (MASH) crashworthiness requirements based on roadway speed and barrier application.
- Water ballasted systems used to channelize vehicular traffic shall be supplemented with retroreflective delineation or channelizing devices to improve daytime/nighttime visibility. They may also be supplemented with pavement markings.
- Water ballasted systems used as barriers shall be placed in accordance to application and installation requirements specific to the device, and used only when shown on the CWZTCD list.
- Water ballasted systems used as barriers should not be used for a merging taper except in low speed (less than 45 MPH) urban areas. When used on a taper in a low speed urban area, the taper shall be delineated and the taper length should be designed to optimize road user operations considering the available geometric conditions.
- When water ballasted systems used as barriers have blunt ends exposed to traffic, they should be attenuated as per manufacturer recommendations or flared to a point outside the clear zone.

If used to channelize pedestrians, longitudinal channelizing devices or water ballasted systems must have a continuous detectable bottom for users of long canes and the top of the unit shall not be less than 32 inches in height.

HOLLOW OR WATER BALLASTED SYSTEMS USED AS LONGITUDINAL CHANNELIZING DEVICES OR BARRIERS

GENERAL NOTES

- Work Zone channelizing devices illustrated on this sheet may be installed in close proximity to traffic and are suitable for use on high or low speed roadways. The Engineer/Inspector shall ensure that spacing and placement is uniform and in accordance with the "Texas Manual on Uniform Traffic Control Devices" (TMUTCD).
- Channelizing devices shown on this sheet may have a driveable, fixed or portable base. The requirement for self-righting channelizing devices must be specified in the General Notes or other plan sheets.
- Channelizing devices on self-righting supports should be used in work zone areas where channelizing devices are frequently impacted by errant vehicles or vehicle related wind gusts making alignment of the channelizing devices difficult to maintain. Locations of these devices shall be detailed elsewhere in the plans. These devices shall conform to the TMUTCD and the "Compliant Work Zone Traffic Control Devices List" (CWZTCD).
- The Contractor shall maintain devices in a clean condition and replace damaged, nonreflective, faded, or broken devices and bases as required by the Engineer/Inspector. The Contractor shall be required to maintain proper device spacing and alignment.
- Portable bases shall be fabricated from virgin and/or recycled rubber. The portable bases shall weigh a minimum of 30 lbs.
- Pavement surfaces shall be prepared in a manner that ensures proper bonding between the adhesives, the fixed mount bases and the pavement surface. Adhesives shall be prepared and applied according to the manufacturer's recommendations.
- The installation and removal of channelizing devices shall not cause detrimental effects to the final pavement surfaces, including pavement surface discoloration or surface integrity. Driveable bases shall not be permitted on final pavement surfaces. The Engineer/Inspector shall approve all application and removal procedures of fixed bases.

Posted Speed	Formula	Minimum Desirable Taper Lengths * *			Suggested Maximum Spacing of Channelizing Devices	
		10' Offset	11' Offset	12' Offset	On a Taper	On a Tangent
30	L = WS ² / 60	150'	165'	180'	30'	60'
35		205'	225'	245'	35'	70'
40		265'	295'	320'	40'	80'
45	L = WS	450'	495'	540'	45'	90'
50		500'	550'	600'	50'	100'
55		550'	605'	660'	55'	110'
60		600'	660'	720'	60'	120'
65		650'	715'	780'	65'	130'
70		700'	770'	840'	70'	140'
75		750'	825'	900'	75'	150'
80		800'	880'	960'	80'	160'

* * * Taper lengths have been rounded off.
 L=Length of Taper (FT.) W=Width of Offset (FT.)
 S=Posted Speed (MPH)

SUGGESTED MAXIMUM SPACING OF CHANNELIZING DEVICES AND MINIMUM DESIRABLE TAPER LENGTHS

SHEET 9 OF 12



BARRICADE AND CONSTRUCTION CHANNELIZING DEVICES

BC (9) - 21

FILE: bc-21.dgn	DN: TxDOT	CR: TxDOT	DW: TxDOT	CK: TxDOT
© TxDOT November 2002	CONT	SECT	JOB	HIGHWAY
REVISIONS	0010	08	060	US 67
9-07 8-14	DIST	COUNTY	SHEET NO.	
7-13 5-21	ATL	MORRIS	22	

DATE: 1/11/2024 2:02:43 PM
 FILE: I:\engdata\Traffic\DGND\192515_Jamie\JOBS\LIGHTING PROJECTS\Lighting Project May 2024\standards.bc-21 (1).dgn
 DISCLAIMER: The use of this standard is governed by the "Texas Engineering Practice Act". No warranty of any kind is made by TxDOT for any purpose whatsoever. TxDOT assumes no responsibility for the conversion of this standard to other formats or for incorrect results or damages resulting from its use.

TYPE 3 BARRICADES

1. Refer to the Compliant Work Zone Traffic Control Devices List (CWZTCD) for details of the Type 3 Barricades and a list of all materials used in the construction of Type 3 Barricades.
2. Type 3 Barricades shall be used at each end of construction projects closed to all traffic.
3. Barricades extending across a roadway should have stripes that slope downward in the direction toward which traffic must turn in detouring. When both right and left turns are provided, the chevron striping may slope downward in both directions from the center of the barricade. Where no turns are provided at a closed road, striping should slope downward in both directions toward the center of roadway.
4. Striping of rails, for the right side of the roadway, should slope downward to the left. For the left side of the roadway, striping should slope downward to the right.
5. Identification markings may be shown only on the back of the barricade rails. The maximum height of letters and/or company logos used for identification shall be 1".
6. Barricades shall not be placed parallel to traffic unless an adequate clear zone is provided.
7. Warning lights shall NOT be installed on barricades.
8. Where barricades require the use of weights to keep from turning over, the use of sandbags with dry, cohesionless sand is recommended. The sandbags will be tied shut to keep the sand from spilling and to maintain a constant weight. Sand bags shall not be stacked in a manner that covers any portion of a barricade rails reflective sheeting. Rock, concrete, iron, steel or other solid objects will NOT be permitted. Sandbags should weigh a minimum of 35 lbs and a maximum of 50 lbs. Sandbags shall be made of a durable material that tears upon vehicular impact. Rubber (such as tire inner tubes) shall not be used for sandbags. Sandbags shall only be placed along or upon the base supports of the device and shall not be suspended above ground level or hung with rope, wire, chains or other fasteners.
9. Sheeting for barricades shall be retroreflective Type A or Type B conforming to Departmental Material Specification DMS-8300 unless otherwise noted.

Barricades shall NOT be used as a sign support.



TYPICAL STRIPING DETAIL FOR BARRICADE RAIL



Stiffener may be inside or outside of support, but no more than 2 stiffeners shall be allowed on one barricade.

TYPICAL PANEL DETAIL FOR SKID OR POST TYPE BARRICADES

Each roadway of a divided highway shall be barricaded in the same manner.

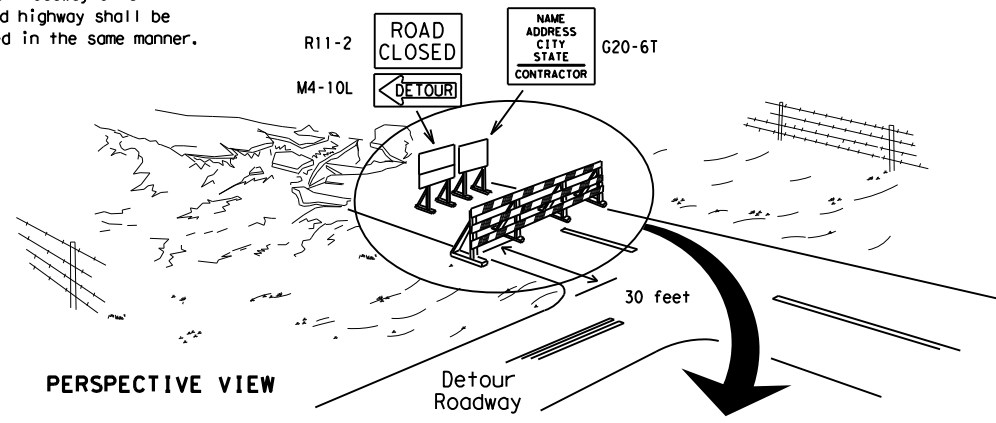

PERSPECTIVE VIEW

The three rails on Type 3 barricades shall be reflectorized orange and reflective white stripes on one side facing one-way traffic and both sides for two-way traffic. Barricade striping should slant downward in the direction of detour.

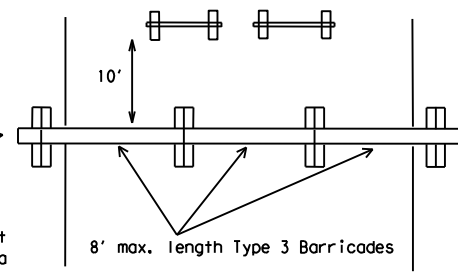

PLAN VIEW

1. Signs should be mounted on independent supports at a 7 foot mounting height in center of roadway. The signs should be a minimum of 10 feet behind Type 3 Barricades.
2. Advance signing shall be as specified elsewhere in the plans.

TYPE 3 BARRICADE (POST AND SKID) TYPICAL APPLICATION

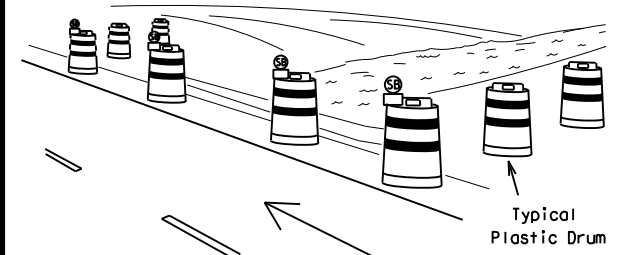

PERSPECTIVE VIEW

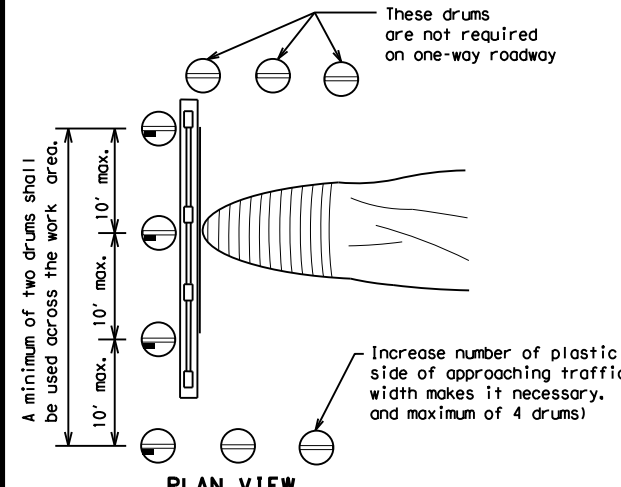

PLAN VIEW

CULVERT WIDENING OR OTHER ISOLATED WORK WITHIN THE PROJECT LIMITS

1. Where positive redirection capability is provided, drums may be omitted.
2. Plastic construction fencing may be used with drums for safety as required in the plans.
3. Vertical Panels on flexible support may be substituted for drums when the shoulder width is less than 4 feet.
4. When the shoulder width is greater than 12 feet, steady-burn lights may be omitted if drums are used.
5. Drums must extend the length of the culvert widening.

LEGEND	
	Plastic drum
	Plastic drum with steady burn light or yellow warning reflector
	Steady burn warning light or yellow warning reflector

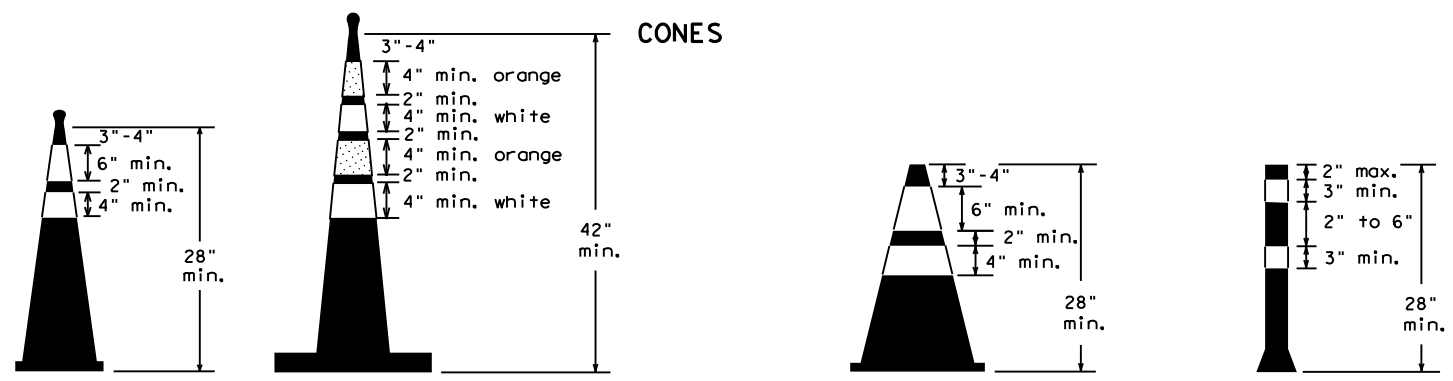

Two-Piece cones

One-Piece cones

Tubular Marker

28" Cones shall have a minimum weight of 9 1/2 lbs.
 42" 2-piece cones shall have a minimum weight of 30 lbs. including base.

1. Traffic cones and tubular markers shall be predominantly orange, and meet the height and weight requirements shown above.
2. One-piece cones have the body and base of the cone molded in one consolidated unit. Two-piece cones have a cone shaped body and a separate rubber base, or ballast, that is added to keep the device upright and in place.
3. Two-piece cones may have a handle or loop extending up to 8" above the minimum height shown, in order to aid in retrieving the device.
4. Cones or tubular markers shall have white or white and orange reflective bands as shown above. The reflective bands shall have a smooth, sealed outer surface and meet the requirements of Departmental Material Specification DMS-8300 Type A or Type B.
5. 28" cones and tubular markers are generally suitable for short duration and short-term stationary work as defined on BC(4). These should not be used for intermediate-term or long-term stationary work unless personnel is on-site to maintain them in their proper upright position.
6. 42" two-piece cones, vertical panels or drums are suitable for all work zone durations.
7. Cones or tubular markers used on each project should be of the same size and shape.

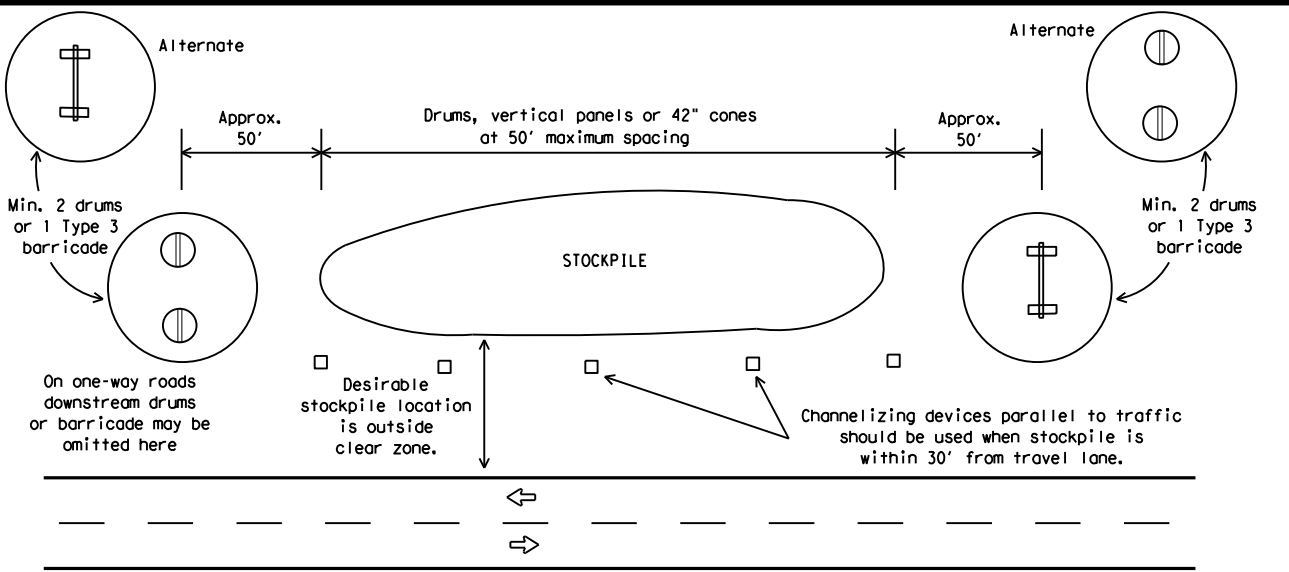

TRAFFIC CONTROL FOR MATERIAL STOCKPILES

BARRICADE AND CONSTRUCTION CHANNELIZING DEVICES

BC (10) -21

FILE: bc-21.dgn	DN: TxDOT	CK: TxDOT	OW: TxDOT	CR: TxDOT
© TxDOT November 2002	CONT	SECT	JOB	HIGHWAY
REVISIONS	0010	08	060	US 67
9-07 8-14	DIST	COUNTY	SHEET NO.	
7-13 5-21	ATL	MORRIS	23	

WORK ZONE PAVEMENT MARKINGS

GENERAL

- The Contractor shall be responsible for maintaining work zone and existing pavement markings, in accordance with the standard specifications and special provisions, on all roadways open to traffic within the CSJ limits unless otherwise stated in the plans.
- Color, patterns and dimensions shall be in conformance with the "Texas Manual on Uniform Traffic Control Devices" (TMUTCD).
- Additional supplemental pavement marking details may be found in the plans or specifications.
- Pavement markings shall be installed in accordance with the TMUTCD and as shown on the plans.
- When short term markings are required on the plans, short term markings shall conform with the TMUTCD, the plans and details as shown on the Standard Plan Sheet WZ(STPM).
- When standard pavement markings are not in place and the roadway is opened to traffic, DO NOT PASS signs shall be erected to mark the beginning of the sections where passing is prohibited and PASS WITH CARE signs at the beginning of sections where passing is permitted.
- All work zone pavement markings shall be installed in accordance with Item 662, "Work Zone Pavement Markings."

RAISED PAVEMENT MARKERS

- Raised pavement markers are to be placed according to the patterns on BC(12).
- All raised pavement markers used for work zone markings shall meet the requirements of Item 672, "RAISED PAVEMENT MARKERS" and Departmental Material Specification DMS-4200 or DMS-4300.

PREFABRICATED PAVEMENT MARKINGS

- Removable prefabricated pavement markings shall meet the requirements of DMS-8241.
- Non-removable prefabricated pavement markings (foil back) shall meet the requirements of DMS-8240.

MAINTAINING WORK ZONE PAVEMENT MARKINGS

- The Contractor will be responsible for maintaining work zone pavement markings within the work limits.
- Work zone pavement markings shall be inspected in accordance with the frequency and reporting requirements of work zone traffic control device inspections as required by Form 599.
- The markings should provide a visible reference for a minimum distance of 300 feet during normal daylight hours and 160 feet when illuminated by automobile low-beam headlights at night, unless sight distance is restricted by roadway geometrics.
- Markings failing to meet this criteria within the first 30 days after placement shall be replaced at the expense of the Contractor as per Specification Item 662.

REMOVAL OF PAVEMENT MARKINGS

- Pavement markings that are no longer applicable, could create confusion or direct a motorist toward or into the closed portion of the roadway shall be removed or obliterated before the roadway is opened to traffic.
- The above shall not apply to detours in place for less than three days, where flaggers and/or sufficient channelizing devices are used in lieu of markings to outline the detour route.
- Pavement markings shall be removed to the fullest extent possible, so as not to leave a discernable marking. This shall be by any method approved by TxDOT Specification Item 677 for "Eliminating Existing Pavement Markings and Markers".
- The removal of pavement markings may require resurfacing or seal coating portions of the roadway as described in Item 677.
- Subject to the approval of the Engineer, any method that proves to be successful on a particular type pavement may be used.
- Blast cleaning may be used but will not be required unless specifically shown in the plans.
- Over-painting of the markings SHALL NOT BE permitted.
- Removal of raised pavement markers shall be as directed by the Engineer.
- Removal of existing pavement markings and markers will be paid for directly in accordance with Item 677, "ELIMINATING EXISTING PAVEMENT MARKINGS AND MARKERS," unless otherwise stated in the plans.
- Black-out marking tape may be used to cover conflicting existing markings for periods less than two weeks when approved by the Engineer.

Temporary Flexible-Reflective Roadway Marker Tabs

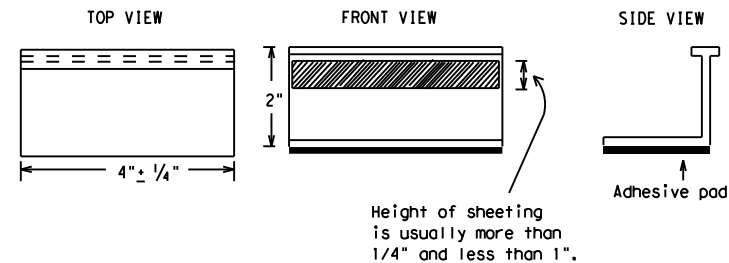

**STAPLES OR NAILS SHALL NOT BE USED TO SECURE
TEMPORARY FLEXIBLE-REFLECTIVE ROADWAY MARKER
TABS TO THE PAVEMENT SURFACE**

- Temporary flexible-reflective roadway marker tabs used as guidemarks shall meet the requirements of DMS-8242.
- Tabs detailed on this sheet are to be inspected and accepted by the Engineer or designated representative. Sampling and testing is not normally required, however at the option of the Engineer, either "A" or "B" below may be imposed to assure quality before placement on the roadway.
 - Select five (5) or more tabs at random from each lot or shipment and submit to the Construction Division, Materials and Pavement Section to determine specification compliance.
 - Select five (5) tabs and perform the following test. Affix five (5) tabs at 24 inch intervals on an asphaltic pavement in a straight line. Using a medium size passenger vehicle or pickup, run over the markers with the front and rear tires at a speed of 35 to 40 miles per hour, four (4) times in each direction. No more than one (1) out of the five (5) reflective surfaces shall be lost or displaced as a result of this test.
- Small design variances may be noted between tab manufacturers.
- See Standard Sheet WZ(STPM) for tab placement on new pavements. See Standard Sheet TCP(7-1) for tab placement on seal coat work.

RAISED PAVEMENT MARKERS USED AS GUIDEMARKS

- Raised pavement markers used as guidemarks shall be from the approved product list, and meet the requirements of DMS-4200.
- All temporary construction raised pavement markers provided on a project shall be of the same manufacturer.
- Adhesive for guidemarks shall be bituminous material hot applied or butyl rubber pad for all surfaces, or thermoplastic for concrete surfaces.

Guidemarks shall be designated as:
 YELLOW - (two amber reflective surfaces with yellow body).
 WHITE - (one silver reflective surface with white body).

DEPARTMENTAL MATERIAL SPECIFICATIONS	
PAVEMENT MARKERS (REFLECTORIZED)	DMS-4200
TRAFFIC BUTTONS	DMS-4300
EPOXY AND ADHESIVES	DMS-6100
BITUMINOUS ADHESIVE FOR PAVEMENT MARKERS	DMS-6130
PERMANENT PREFABRICATED PAVEMENT MARKINGS	DMS-8240
TEMPORARY REMOVABLE, PREFABRICATED PAVEMENT MARKINGS	DMS-8241
TEMPORARY FLEXIBLE, REFLECTIVE ROADWAY MARKER TABS	DMS-8242

A list of prequalified reflective raised pavement markers, non-reflective traffic buttons, roadway marker tabs and other pavement markings can be found at the Material Producer List web address shown on BC(1).

SHEET 11 OF 12



BARRICADE AND CONSTRUCTION PAVEMENT MARKINGS

BC(11)-21

FILE: bc-21.dgn	DN: TxDOT	CR: TxDOT	DW: TxDOT	CK: TxDOT
© TxDOT February 1998	CONT	SECT	JOB	HIGHWAY
REVISIONS	0010	08	060	US 67
2-98 9-07 5-21	DIST	COUNTY	SHEET NO.	
1-02 7-13	ATL	MORRIS	24	
11-02 8-14				

DISCLAIMER: The use of this standard is governed by the "Texas Engineering Practice Act". No warranty of any kind is made by TxDOT for any purpose whatsoever. TxDOT assumes no responsibility for the conversion of this standard to other formats or for incorrect results or damages resulting from its use.
 DATE: 1/11/2024 2:03:13 PM
 FILE: I:\Engdat\Traffic\DGND\192515_Jamie\JOBS\LIGHTING PROJECTS\Lighting Project_May_2024\standards\bc-21(1).dgn

PAVEMENT MARKING PATTERNS

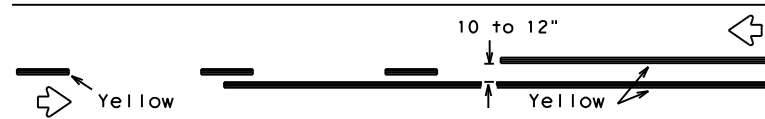

REFLECTORIZED PAVEMENT MARKINGS - PATTERN A

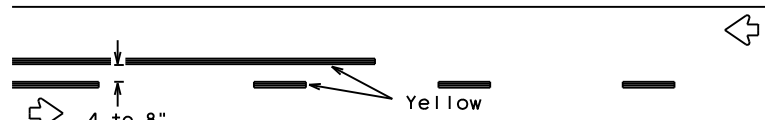

REFLECTORIZED PAVEMENT MARKINGS - PATTERN B

Pattern A is the TXDOT Standard, however Pattern B may be used if approved by the Engineer. Prefabricated markings may be substituted for reflectORIZED pavement markings.

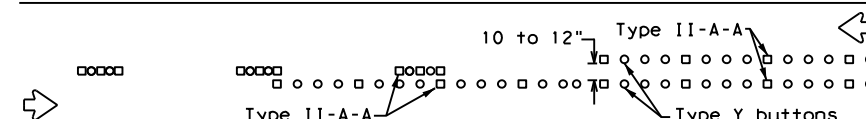

RAISED PAVEMENT MARKERS - PATTERN A

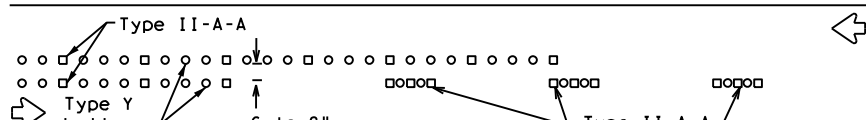

RAISED PAVEMENT MARKERS - PATTERN B

CENTER LINE & NO-PASSING ZONE BARRIER LINES FOR TWO-LANE, TWO-WAY HIGHWAYS



REFLECTORIZED PAVEMENT MARKINGS

Prefabricated markings may be substituted for reflectORIZED pavement markings.

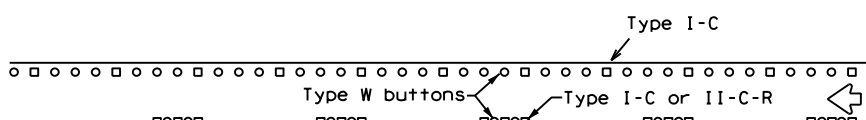

RAISED PAVEMENT MARKERS

EDGE & LANE LINES FOR DIVIDED HIGHWAY

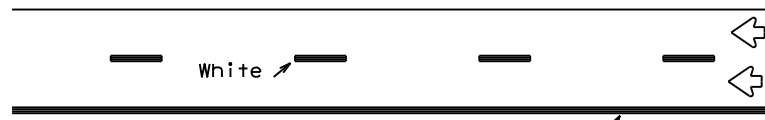

REFLECTORIZED PAVEMENT MARKINGS

Prefabricated markings may be substituted for reflectORIZED pavement markings.

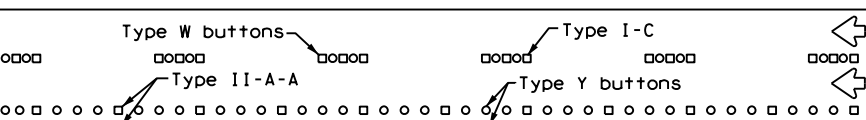

RAISED PAVEMENT MARKERS

LANE & CENTER LINES FOR MULTILANE UNDIVIDED HIGHWAYS

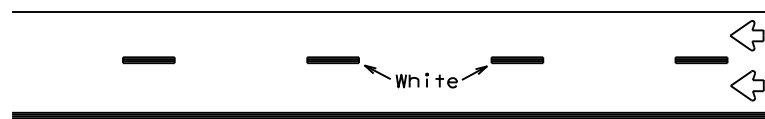

REFLECTORIZED PAVEMENT MARKINGS

Prefabricated markings may be substituted for reflectORIZED pavement markings.

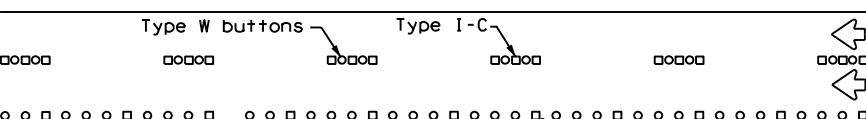

RAISED PAVEMENT MARKERS

TWO-WAY LEFT TURN LANE

STANDARD WORK ZONE PAVEMENT MARKINGS DETAILS

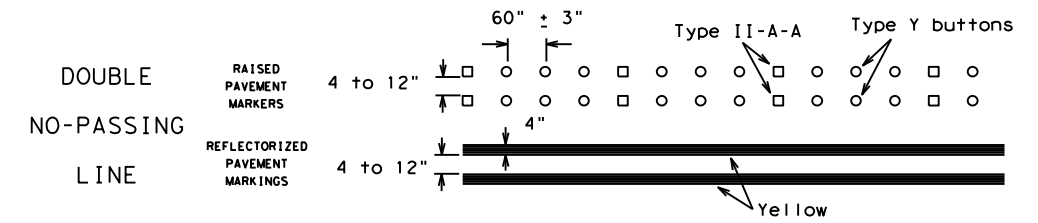

SOLID LINES

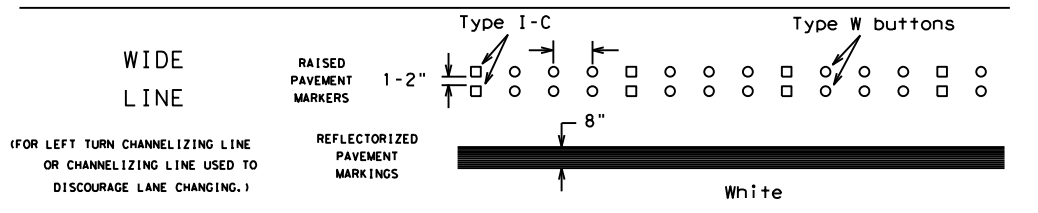
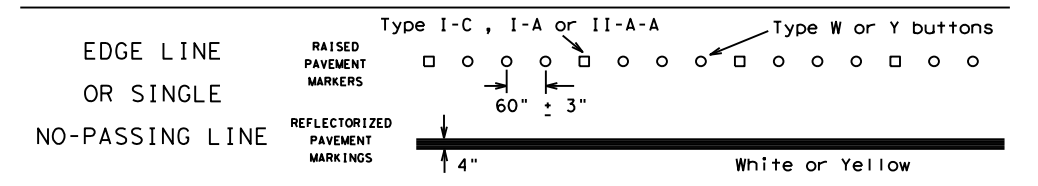

BROKEN LINES

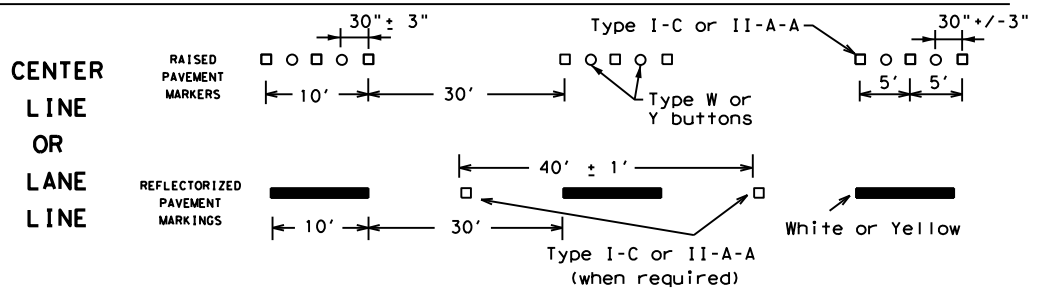

AUXILIARY OR LANEDROP LINE

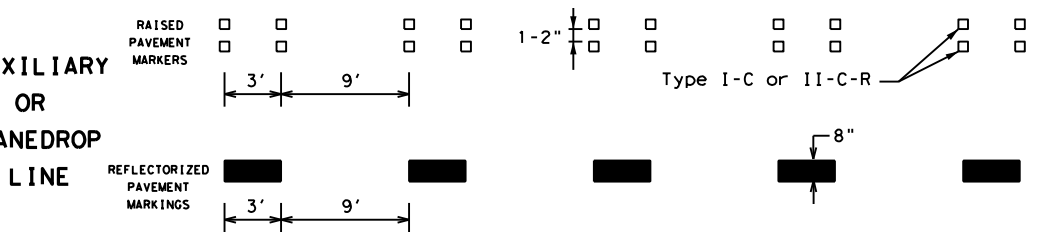

REMOVABLE MARKINGS WITH RAISED PAVEMENT MARKERS

If raised pavement markers are used to supplement REMOVABLE markings, the markers shall be applied to the top of the tape at the approximate mid length of tape used for broken lines or at 20 foot spacing for solid lines. This allows an easier removal of raised pavement markers and tape.

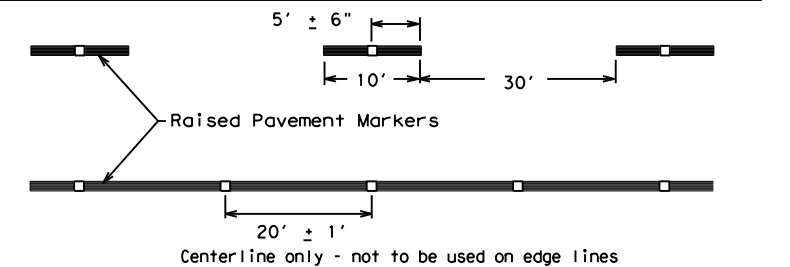

SHEET 12 OF 12



BARRICADE AND CONSTRUCTION PAVEMENT MARKING PATTERNS

BC(12)-21

Raised pavement markers used as standard pavement markings shall be from the approved products list and meet the requirements of Item 672 "RAISED PAVEMENT MARKERS."

FILE: bc-21.dgn	DN: TxDOT	CK: TxDOT	OW: TxDOT	CR: TxDOT
©TxDOT February 1998	CONT	SECT	JOB	HIGHWAY
REVISIONS	0010	08	060	US 67
1-97 9-07 5-21	DIST	COUNTY	SHEET NO.	
2-98 7-13	ATL	MORRIS	25	
11-02 8-14				

DISCLAIMER: The use of this standard is governed by the "Texas Engineering Practice Act". No warranty of any kind is made by TxDOT for any purpose whatsoever. TxDOT assumes no responsibility for the conversion of this standard to other formats or for incorrect results or damages resulting from its use.
 DATE: 1/11/2024 2:03:37 PM
 FILE: I:\engdata\Traffic\DGND\192515_Jamie\JOBS\LIGHTING PROJECTS\Lighting Project May 2024\standards\bc-21(1).dgn

DATE: 1/11/2024 2:04:10 PM
 FILE: T:\Engdat\Traffic\DGND\192515_Jamie\JOBS\LIGHTING PROJECTS\Lighting of 01-18-2024.dgn

DISCLAIMER:

The use of this standard is governed by the "Texas Engineering Practice Act". No warranty of any kind is made by TxDOT for any purpose whatsoever. TxDOT assumes no responsibility for the conversion of units or for any errors or omissions that may appear in this standard or for damages resulting from its use.

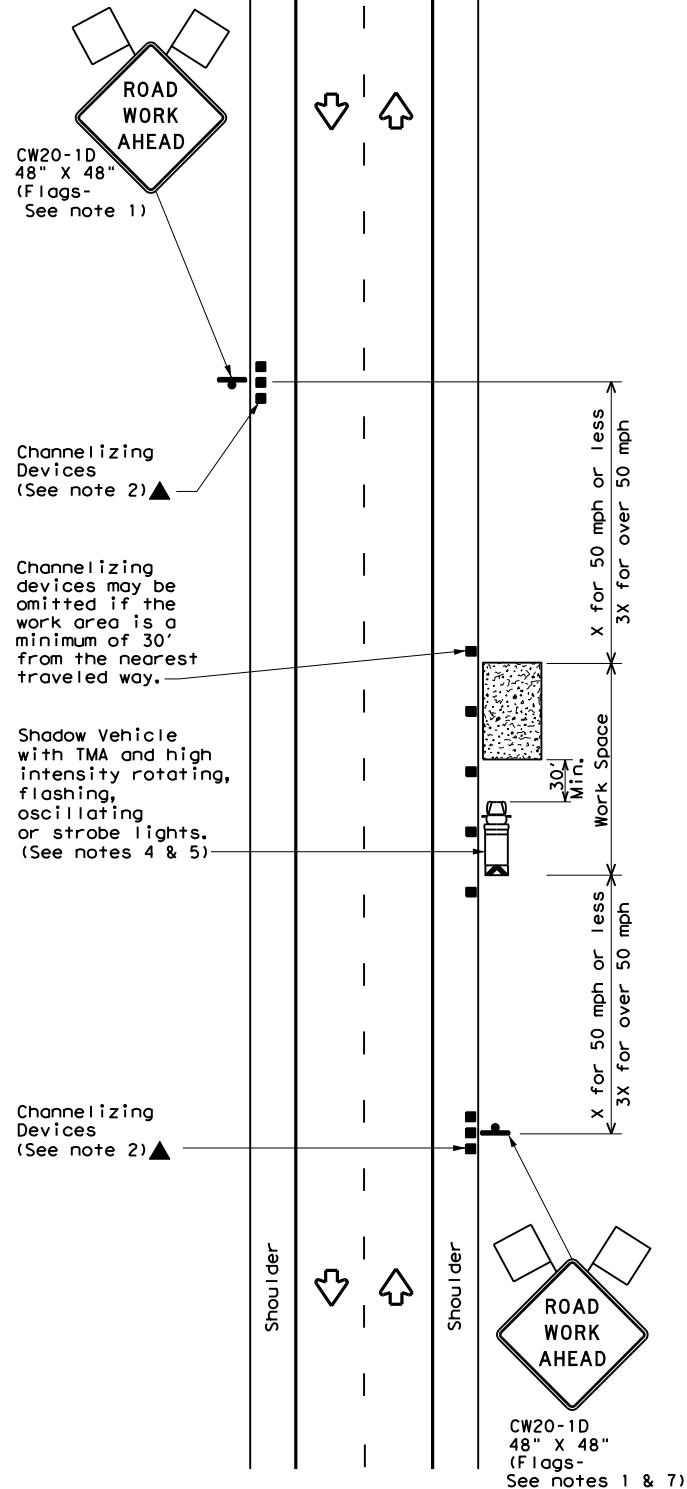

TCP (1-1a)

WORK SPACE NEAR SHOULDER
Conventional Roads

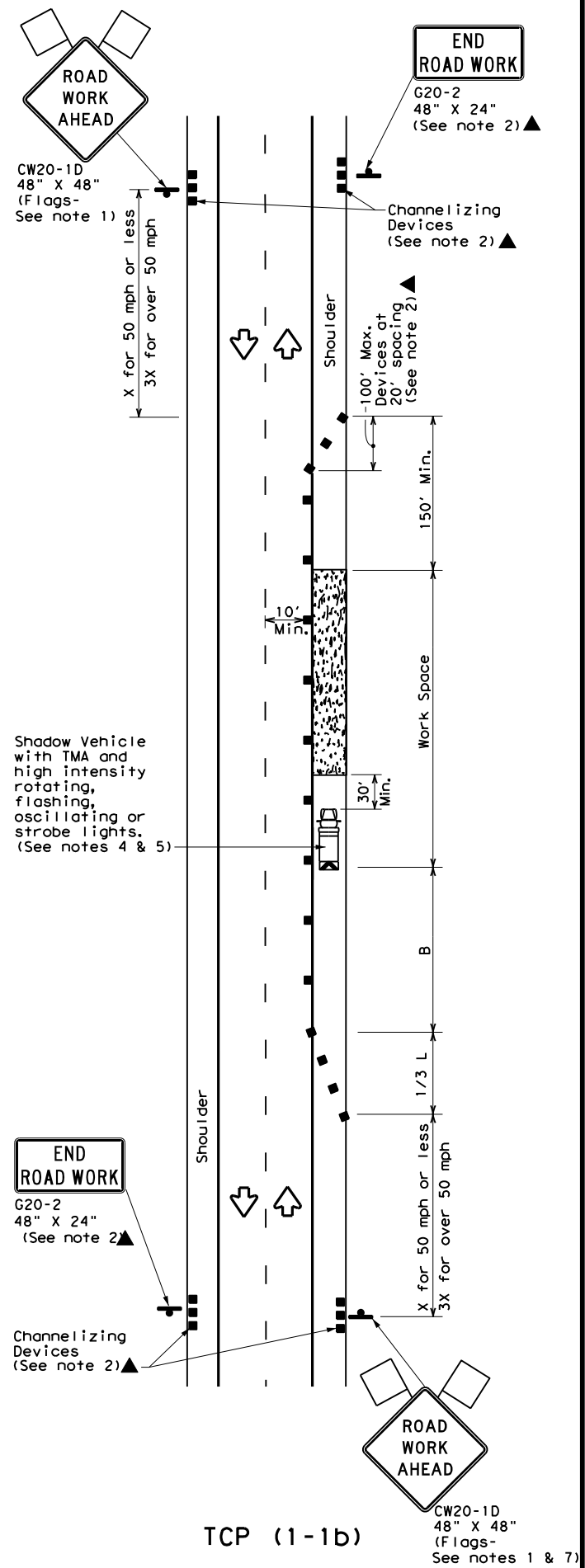

TCP (1-1b)

WORK SPACE ON SHOULDER
Conventional Roads

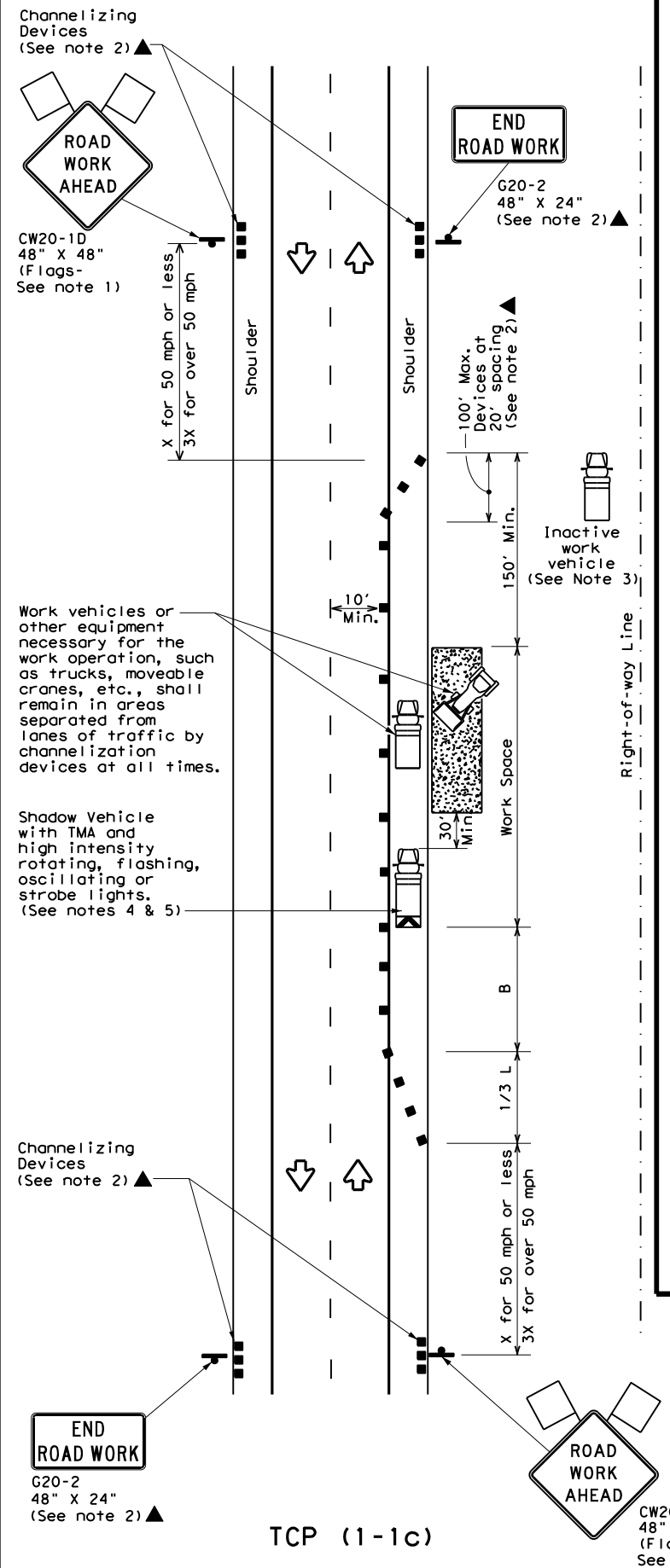

TCP (1-1c)

WORK VEHICLES ON SHOULDER
Conventional Roads

LEGEND			
	Type 3 Barricade		Channelizing Devices
	Heavy Work Vehicle		Truck Mounted Attenuator (TMA)
	Trailer Mounted Flashing Arrow Board		Portable Changeable Message Sign (PCMS)
	Sign		Traffic Flow
	Flag		Flagger

Posted Speed * S	Formula L = WS / 60	Minimum Desirable Taper Lengths **			Suggested Maximum Spacing of Channelizing Devices		Minimum Sign Spacing "X" Distance	Suggested Longitudinal Buffer Space "B"
		10' Offset	11' Offset	12' Offset	On a Taper	On a Tangent		
30		150'	165'	180'	30'	60'	120'	90'
35		205'	225'	245'	35'	70'	160'	120'
40		265'	295'	320'	40'	80'	240'	155'
45		450'	495'	540'	45'	90'	320'	195'
50		500'	550'	600'	50'	100'	400'	240'
55		550'	605'	660'	55'	110'	500'	295'
60		600'	660'	720'	60'	120'	600'	350'
65		650'	715'	780'	65'	130'	700'	410'
70		700'	770'	840'	70'	140'	800'	475'
75		750'	825'	900'	75'	150'	900'	540'

* Conventional Roads Only
 ** Taper lengths have been rounded off.
 L=Length of Taper (FT) W=Width of Offset (FT) S=Posted Speed (MPH)

TYPICAL USAGE				
MOBILE	SHORT DURATION	SHORT TERM STATIONARY	INTERMEDIATE TERM STATIONARY	LONG TERM STATIONARY
	✓	✓		

- GENERAL NOTES**
- Flags attached to signs where shown are REQUIRED.
 - All traffic control devices illustrated are REQUIRED, except those denoted with the triangle symbol may be omitted when stated elsewhere in the plans, or for routine maintenance work, when approved by the Engineer.
 - Inactive work vehicles or other equipment should be parked near the right-of-way line and not parked on the paved shoulder.
 - A Shadow Vehicle with a TMA should be used anytime it can be positioned 30 to 100 feet in advance of the area of crew exposure without adversely affecting the performance or quality of the work. If workers are no longer present but road or work conditions require the traffic control to remain in place, Type 3 Barricades or other channelizing devices may be substituted for the Shadow Vehicle and TMA.
 - Additional Shadow Vehicles with TMAs may be positioned off the paved surface, next to those shown in order to protect wider work spaces.
 - See TCP(5-1) for shoulder work on divided highways, expressways and freeways.
 - CW21-5 "SHOULDER WORK" signs may be used in place of CW20-1D "ROAD WORK AHEAD" signs for shoulder work on conventional roadways.



TRAFFIC CONTROL PLAN
CONVENTIONAL ROAD
SHOULDER WORK

TCP (1-1) - 18

FILE: tcp1-1-18.dgn	DN:	CK:	DW:	CK:
© TxDOT December 1985	CONT	SECT	JOB	HIGHWAY
REVISIONS	0010	08	060	US 67
2-94 4-98	DIST	COUNTY	SHEET NO.	
8-95 2-12	ATL	MORRIS	26	
1-97 2-18				

DISCLAIMER: The use of this standard is governed by the "Texas Engineering Practice Act". No warranty of any kind is made by TxDOT for any purpose whatsoever. TxDOT assumes no responsibility for the conversion of units or the use of this standard in any project. The use of this standard is governed by the "Texas Engineering Practice Act". No warranty of any kind is made by TxDOT for any purpose whatsoever. TxDOT assumes no responsibility for the conversion of units or the use of this standard in any project.

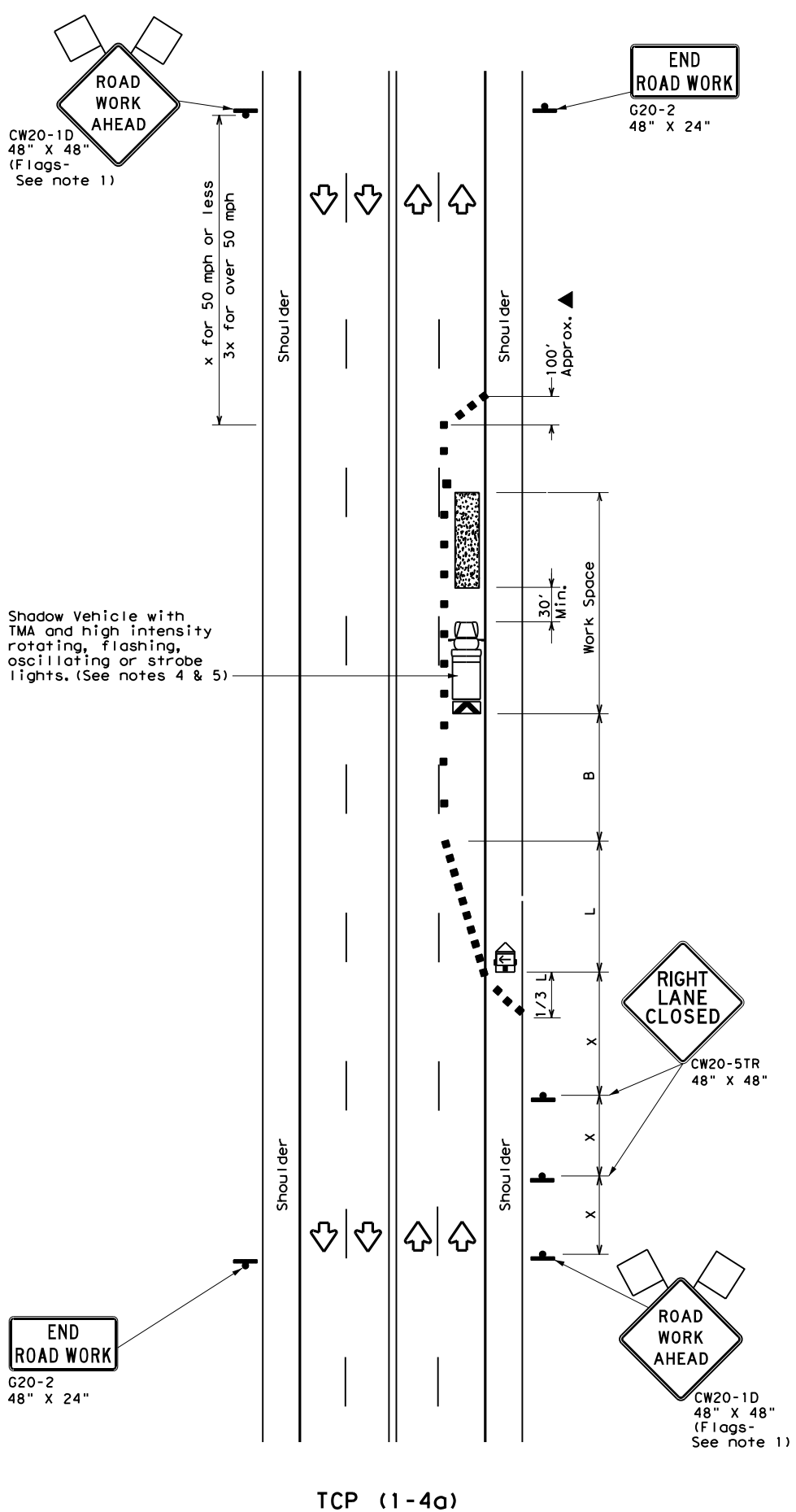

TCP (1-4a)
ONE LANE CLOSED

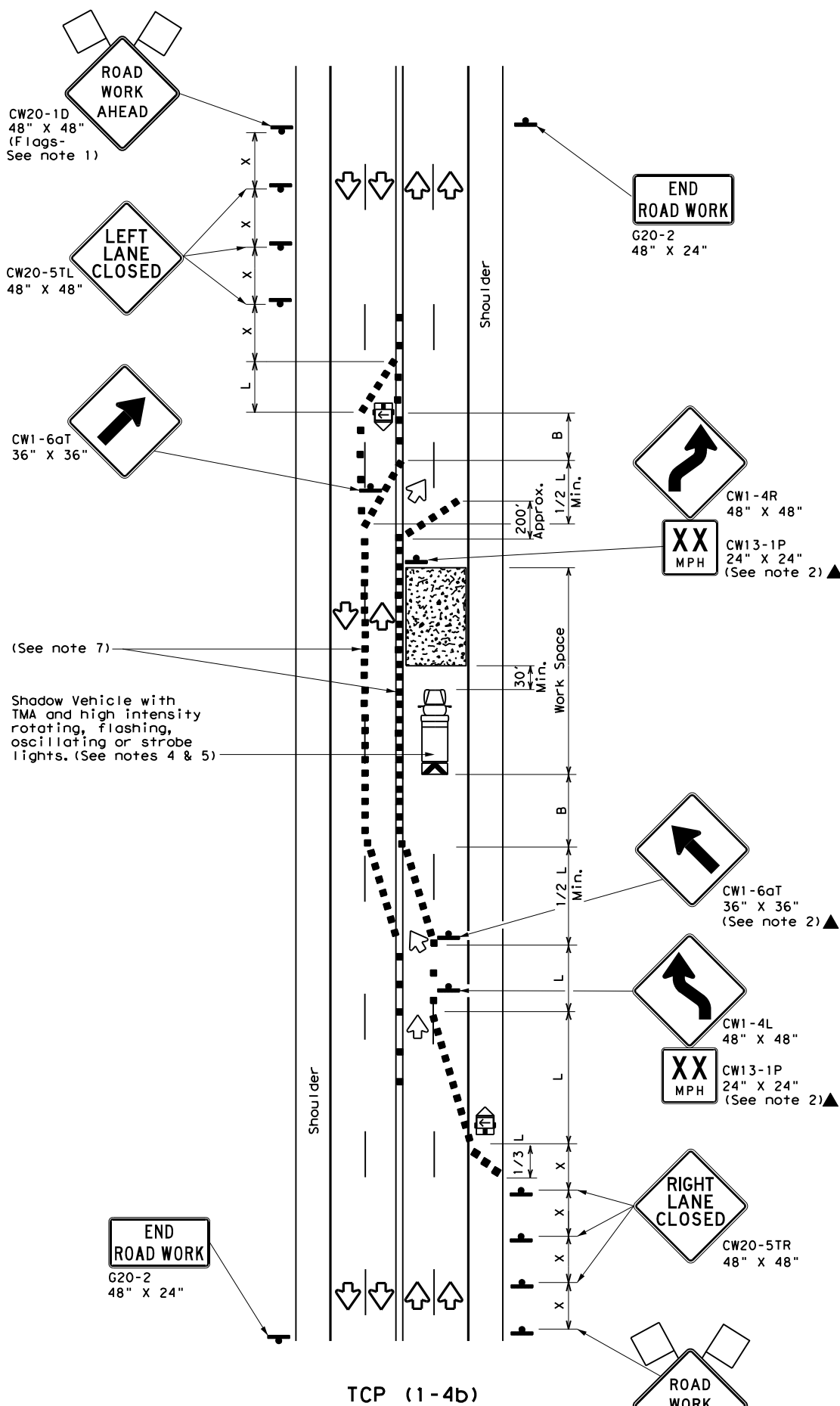

TCP (1-4b)
TWO LANES CLOSED

LEGEND			
	Type 3 Barricade		Channelizing Devices
	Heavy Work Vehicle		Truck Mounted Attenuator (TMA)
	Trailer Mounted Flashing Arrow Board		Portable Changeable Message Sign (PCMS)
	Sign		Traffic Flow
	Flag		Flagger

Posted Speed *	Formula	Minimum Desirable Taper Lengths **			Suggested Maximum Spacing of Channelizing Devices		Minimum Sign Spacing "X" Distance	Suggested Longitudinal Buffer Space "B"
		10' Offset	11' Offset	12' Offset	On a Taper	On a Tangent		
30	$L = \frac{WS^2}{60}$	150'	165'	180'	30'	60'	120'	90'
35		205'	225'	245'	35'	70'	160'	120'
40		265'	295'	320'	40'	80'	240'	155'
45	$L = WS$	450'	495'	540'	45'	90'	320'	195'
50		500'	550'	600'	50'	100'	400'	240'
55		550'	605'	660'	55'	110'	500'	295'
60		600'	660'	720'	60'	120'	600'	350'
65		650'	715'	780'	65'	130'	700'	410'
70		700'	770'	840'	70'	140'	800'	475'
75		750'	825'	900'	75'	150'	900'	540'

* Conventional Roads Only
** Taper lengths have been rounded off.
L=Length of Taper (FT) W=Width of Offset (FT) S=Posted Speed (MPH)

TYPICAL USAGE				
MOBILE	SHORT DURATION	SHORT TERM STATIONARY	INTERMEDIATE TERM STATIONARY	LONG TERM STATIONARY
	✓	✓		

- GENERAL NOTES**
- Flags attached to signs where shown are REQUIRED.
 - All traffic control devices illustrated are REQUIRED, except those denoted with the triangle symbol may be omitted when stated elsewhere in the plans, or for routine maintenance work, when approved by the Engineer.
 - The CW20-1D "ROAD WORK AHEAD" sign may be repeated if the visibility of the work zone is less than 1500 feet.
 - A Shadow Vehicle with a TMA should be used anytime it can be positioned 30 to 100 feet in advance of the area of crew exposure without adversely affecting the performance or quality of the work. If workers are no longer present but road or work conditions require the traffic control to remain in place, Type 3 Barricades or other channelizing devices may be substituted for the Shadow Vehicle and TMA.
 - Additional Shadow Vehicles with TMAs may be positioned off the paved surface, next to those shown in order to protect wider work spaces.

TCP (1-4a)

- If this TCP is used for a left lane closure, CW20-5TL "LEFT LANE CLOSED" signs shall be used and channelizing devices shall be placed on the centerline where needed to protect the work space from opposing traffic with the arrow panel placed in the closed lane near the end of the merging taper.

TCP (1-4b)

- Where traffic is directed over a yellow centerline, channelizing devices which separate two-way traffic should be spaced on tapers at 20' or 15' if posted speeds are 35 mph or slower, and for tangent sections, at 1/2S where S is the speed in mph. This tighter device spacing is intended for the areas of conflicting markings, not the entire work zone.

		Traffic Operations Division Standard	
TRAFFIC CONTROL PLAN LANE CLOSURES ON MULTILANE CONVENTIONAL ROADS			
TCP (1-4) - 18			
FILE:	tcp1-4-18.dgn	DN:	CK:
© TxDOT	December 1985	CONT	SECT
2-94	4-98	0010	08
8-95	2-12	060	US 67
1-97	2-18	DIST	COUNTY
		ATL	MORRIS
			SHEET NO. 29

DATE: 1/11/2024 2:07:57 PM
 FILE: T:\Engdat\Traffic\Lighting\PROJECTS\Lighting\192515_Jamie\JOBS\LIGHTING\PROJECTS\Lighting\192515_Jamie\192515.dgn

Warning sign and rumble strip sequence in opposite direction is same as below.

Flagger to Flagger (Length of Work Area)	ADT	# of Rumble Strip Arrays
1/8 Mile	< 4,500	1
	≥ 4,500	2
1/4 Mile	< 3,500	1
	≥ 3,500	2
1/2 Mile	< 2,600	1
	≥ 2,600	2
1 Mile	< 1,600	1
	≥ 1,600	2
> 1 Mile	N/A	2

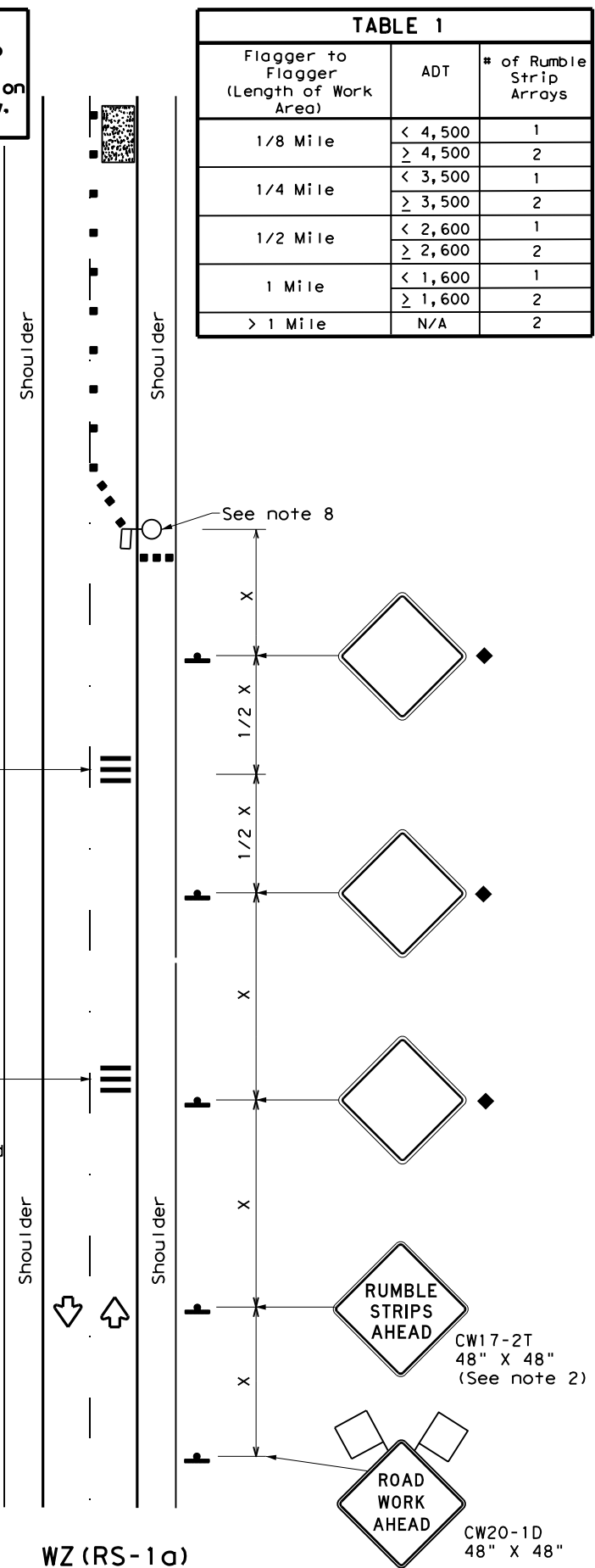

RUMBLE STRIPS ON ONE-LANE TWO-WAY APPLICATION

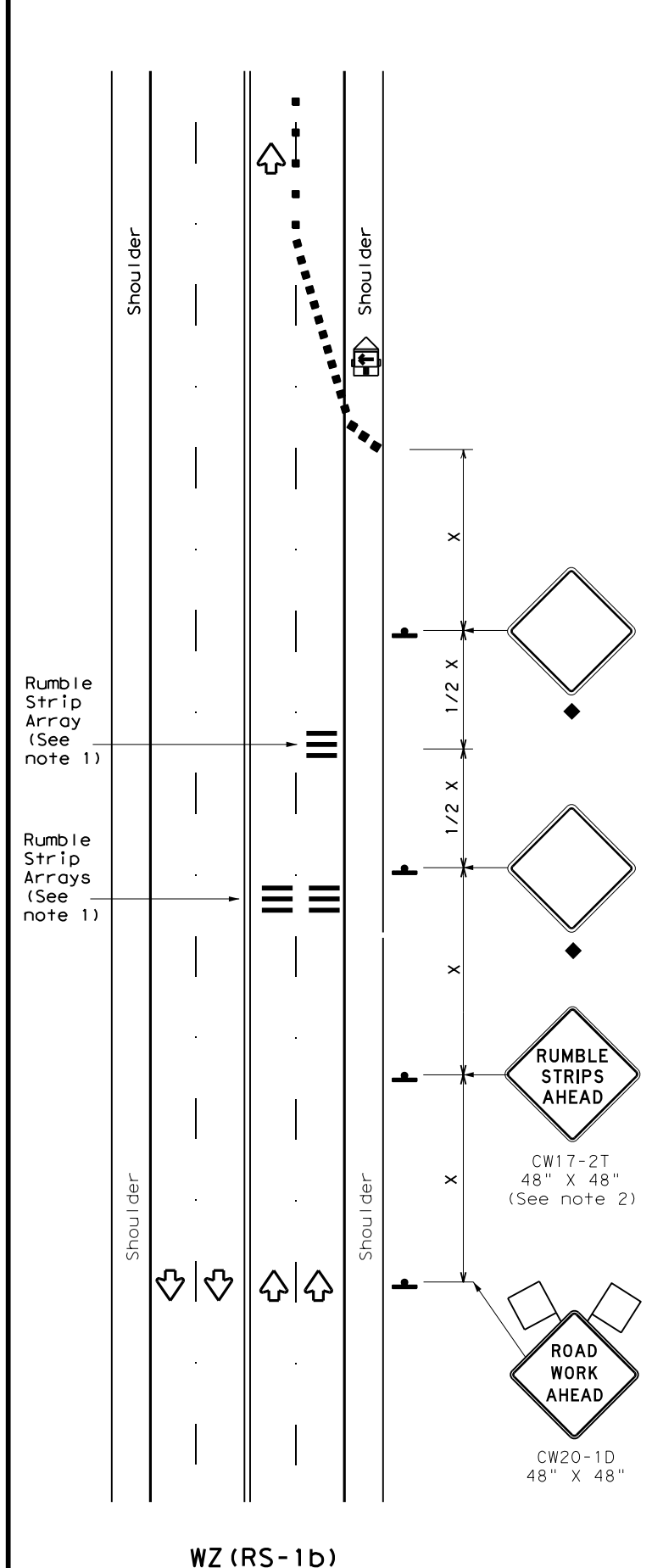

RUMBLE STRIPS FOR LANE CLOSURE ON CONVENTIONAL ROADWAY

GENERAL NOTES

- Each Rumble Strip Array should consist of three rumble strips spaced center to center at the spacing shown in Table 2, placed transverse across the lane at locations shown.
- The CW17-2T "RUMBLE STRIPS AHEAD" sign should be located after the CW20-1D "ROAD WORK AHEAD" sign and spaced as shown. If traffic is observed to be queuing, or is expected to queue beyond the Rumble Strips, the CW17-2T sign and the first Rumble Strip Array may be located upstream of the CW20-1D sign as necessary to provide needed warning.
- Temporary Rumble Strips will be considered subsidiary to Item 502, and shall be a product listed on the Compliant Work Zone Traffic Control Devices.
- Remove Temporary Rumble Strips before removing the advanced warning signs.
- Temporary Rumble Strips should not be used on horizontal curves, loose gravel, soft or bleeding asphalt, heavily rutted pavements or unpaved surfaces.
- Temporary Rumble Strips shall be installed and maintained as per manufacturer's recommendations.
- This standard sheet shall be used in conjunction with other appropriate TCP standard, TMUTCD typical application or project specific detail for the project.
- The one-lane two-way application may utilize a flagger, an Automated Flagger Assistance Device (AFAD) or a Portable Traffic Signal (PTS).
- Replace defective Temporary Rumble Strips as directed by the Engineer.
- Temporary Rumble Strips may be used on freeways or expressways based on engineering judgment and written direction from the Engineer.

Speed	Approximate distance between strips in an array
≤ 40 MPH	10'
> 40 MPH & ≤ 55 MPH	15'
= 60 MPH	20'
≥ 65 MPH	* 35' +

	Type 3 Barricade		Channelizing Devices
	Heavy Work Vehicle		Truck Mounted Attenuator (TMA)
	Trailer Mounted Flashing Arrow Panel		Portable Changeable Message Sign (PCMS)
	Sign		Traffic Flow
	Flag		Flagger

Posted Speed *	Formula	Minimum Desirable Taper Lengths **			Suggested Maximum Spacing of Channelizing Devices		Minimum Sign Spacing "X" Distance	Suggested Longitudinal Buffer Space "B"
		10' Offset	11' Offset	12' Offset	On a Taper	On a Tangent		
30	L = WS ² / 60	150'	165'	180'	30'	60'	120'	90'
35		205'	225'	245'	35'	70'	160'	120'
40		265'	295'	320'	40'	80'	240'	155'
45	L = WS	450'	495'	540'	45'	90'	320'	195'
50		500'	550'	600'	50'	100'	400'	240'
55		550'	605'	660'	55'	110'	500'	295'
60		600'	660'	720'	60'	120'	600'	350'
65		650'	715'	780'	65'	130'	700'	410'
70		700'	770'	840'	70'	140'	800'	475'
75		750'	825'	900'	75'	150'	900'	540'

* Conventional Roads Only
 ** Taper lengths have been rounded off.
 L=Length of Taper (FT) W=Width of Offset (FT)
 S=Posted Speed (MPH)

MOBILE	SHORT DURATION	SHORT TERM STATIONARY	INTERMEDIATE TERM STATIONARY	LONG TERM STATIONARY
	✓	✓		

◆ Signs are for illustrative purposes only. Signs required may vary depending on the TCP, TMUTCD Typical Application, or project specific details for the project.
 * For posted speeds in excess of 65 MPH, it is recommended that spacing is increased as speed limits increase. Increasing space between rumble strips will improve effectiveness.

Texas Department of Transportation Traffic Safety Division Standard

TEMPORARY RUMBLE STRIPS

WZ (RS) - 22

FILE: wzrs22.dgn	DN: TxDOT	CK: TxDOT	DW: TxDOT	CK: TxDOT
© TxDOT November 2012	CONT	SECT	JOB	HIGHWAY
REVISIONS	0010	08	060	US 67
2-14 1-22	DIST	COUNTY	SHEET NO.	
4-16	ATL	MORRIS	32	

DISCLAIMER: The use of this standard is governed by the "Texas Engineering Practice Act". No warranty of any kind is made by TxDOT for any purpose whatsoever. TxDOT assumes no responsibility for the conversion of units or for the accuracy of the information provided. TxDOT is not responsible for any errors or omissions or for any damages resulting from its use.

DATE: 1/11/2024 2:08:36 PM
 FILE: T:\Engdata\Traffic\DGND\192515_Jamie\JOBS\LIGHTING PROJECTS\Lighting

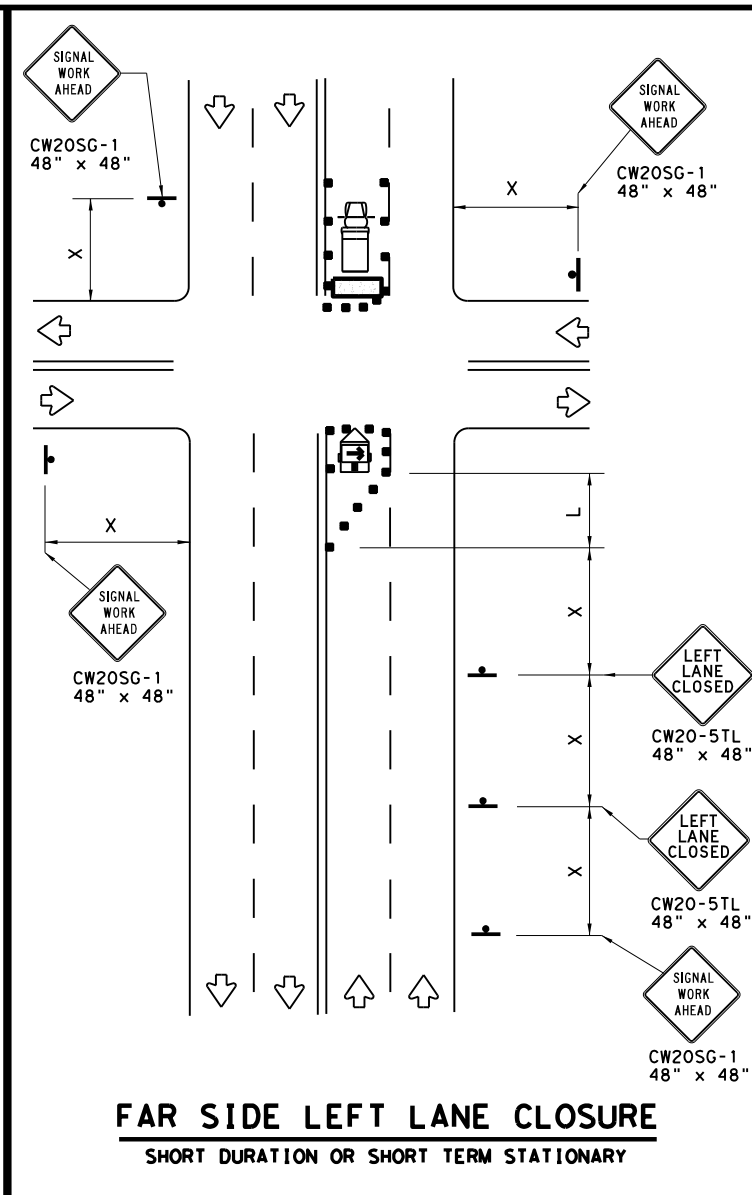
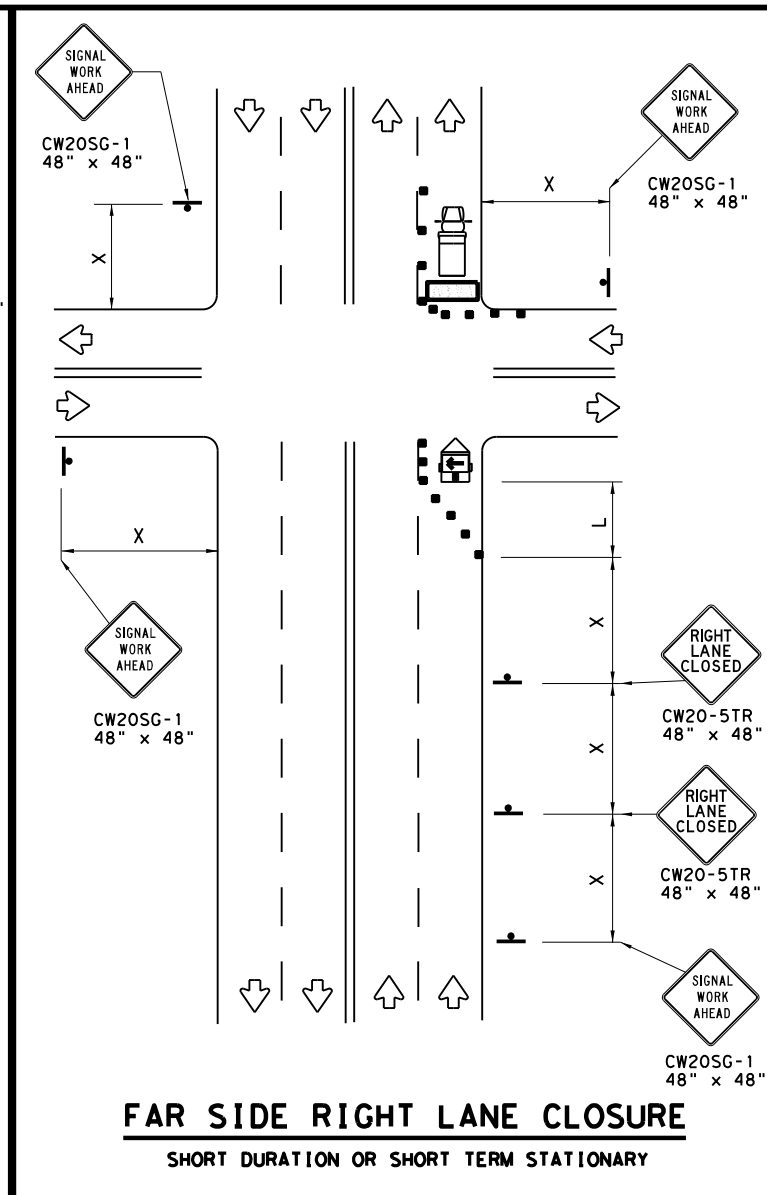
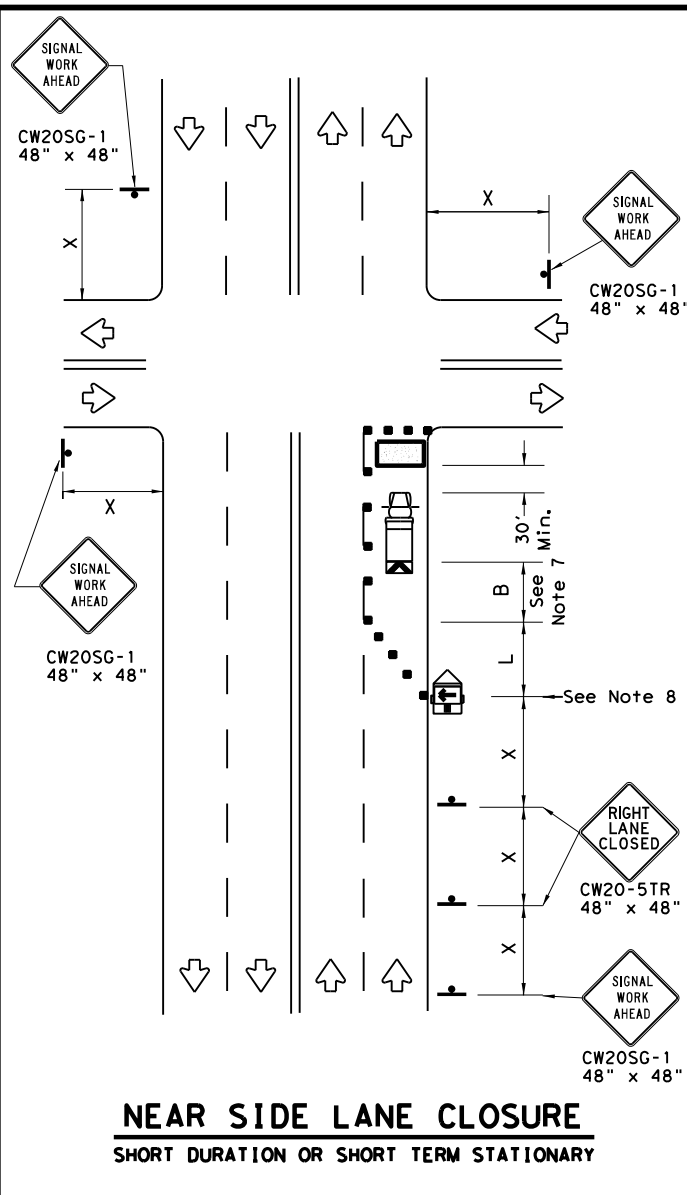

LEGEND

	Type 3 Barricade		Channelizing Devices
	Heavy Work Vehicle		Truck Mounted Attenuator (TMA)
	Trailer Mounted Flashing Arrow Board		Portable Changeable Message Sign (PCMS)
	Sign		Traffic Flow
	Flag		Flagger

Posted Speed *	Formula	Minimum Desirable Taper Lengths **			Suggested Maximum Spacing of Channelizing Devices		Minimum Sign Spacing "X" Distance	Suggested Longitudinal Buffer Space "B"
		10' Offset	11' Offset	12' Offset	On a Taper	On a Tangent		
30	$L = \frac{WS^2}{60}$	150'	165'	180'	30'	60'	120'	90'
35		205'	225'	245'	35'	70'	160'	120'
40		265'	295'	320'	40'	80'	240'	155'
45	L = WS	450'	495'	540'	45'	90'	320'	195'
50		500'	550'	600'	50'	100'	400'	240'
55		550'	605'	660'	55'	110'	500'	295'
60		600'	660'	720'	60'	120'	600'	350'
65		650'	715'	780'	65'	130'	700'	410'
70		700'	770'	840'	70'	140'	800'	475'
75		750'	825'	900'	75'	150'	900'	540'

* Conventional Roads Only
 ** Taper lengths have been rounded off.
 L=Length of Taper (FT) W=Width of Offset (FT) S=Posted Speed (MPH)

WORKERS IN BUCKET TRUCKS SHALL NOT WORK ABOVE OPEN LANES OF TRAFFIC.

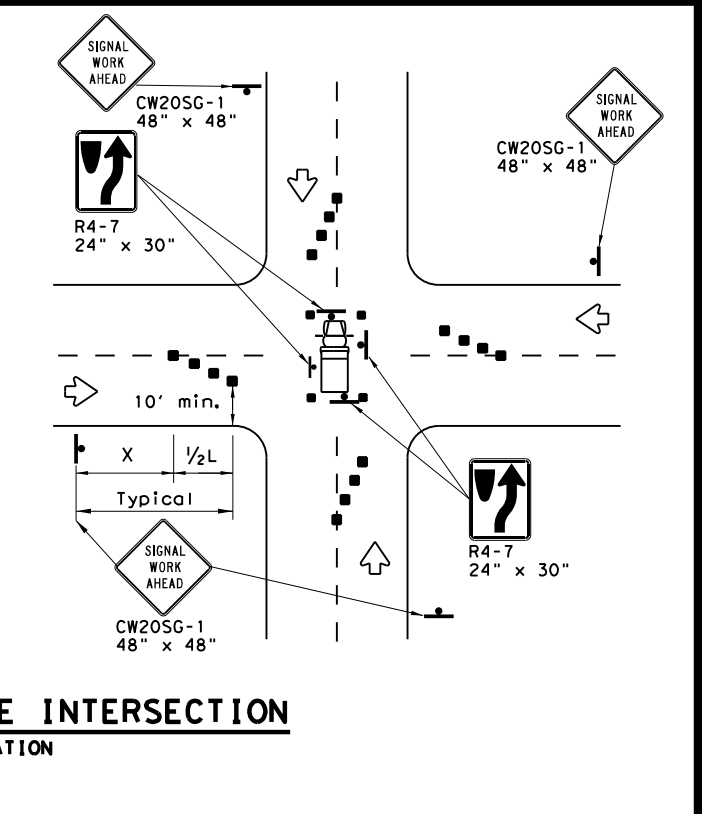
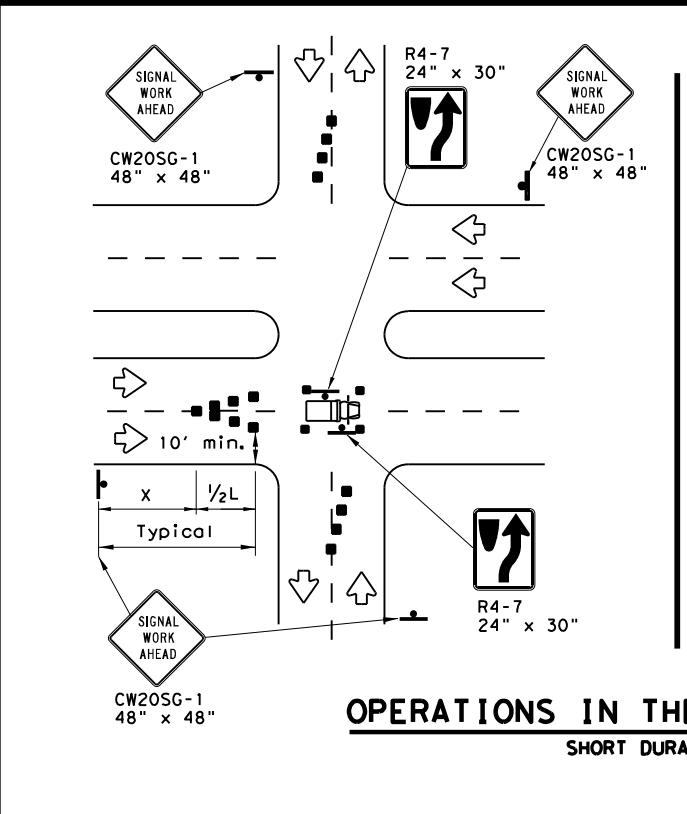

GENERAL NOTES

- The minimum size channelizing device is the 28" cone. 42" Two-piece cones, drums, vertical panels or barricades will be required when the device must be left unattended at night.
- Obstructions or hazards at the work area shall be clearly marked and delineated at all times.
- Flaggers and Flagger Symbol (CW20-7) signs may be required according to field conditions.
- Vehicles parked in roadway shall be equipped with at least two high intensity rotating, flashing, oscillating or strobe type lights.
- High level warning devices (flag trees) may be used at corners of the vehicle.
- When work operations are performed on existing signals, the signals may be placed in flashing red mode when approved by the engineer. If existing signals do not have power, All-Way Stop (R1-1 and R1-3P) signs may be implemented when approved by the engineer.
- For Short-Term Stationary work the buffer space "B" from the above table should be used if field conditions permit. For Short Duration (less than 1 hour) any buffer space provided will enhance the safety of the setup.
- The arrow board at this location may be omitted for Short Duration work if the work vehicle has an arrow board in operation. As an option, the arrow board may be placed at the end of the taper in the closed lane if space is not available at the beginning of the taper.
- Signs and devices for the NEAR SIDE LANE CLOSURE may be altered for a left lane closure by using a LEFT LANE CLOSED (CW20-5TL) and adding channelizing devices on the centerline to protect the work space from opposing traffic.

Texas Department of Transportation
 Traffic Operations Division Standard

TRAFFIC SIGNAL WORK TYPICAL DETAILS

WZ (BTS-1) - 13

FILE: wzbt-13.dgn	DN: TxDOT	CR: TxDOT	DW: TxDOT	CK: TxDOT
© TxDOT April 1992	CONT	SECT	JOB	HIGHWAY
REVISIONS	0010	08	060	US 67
2-98 10-99 7-13	DIST	COUNTY	SHEET NO.	
4-98 3-03	ATL	MORRIS	33	

FILE: T:\engdata\Traffic\DN\192515 Jamie\JOBS\LIGHTING PROJECTS\Lighting Project May 2024\SERVICE.dgn
 DATE: 2/9/2024 6:44:11 AM

ELECTRICAL SERVICE ASSEMBLY SUMMARY													
POWER PROVIDER AND TXDOT SERVICE ID	ELEC. SERVICE NO.	SHEET NO.	ELECTRICAL SERVICE DESCRIPTION (SEE ED (4)&(5))	SERVICE CONDUIT SIZE	SERVICE CONDUCTORS NO./SIZE	SAFETY SWITCH AMPS	MAIN CKT. BKR. POLE/AMP	TWO-POLE CONTACTOR AMPS	PANELBD/LOADCENTER AMP RATING	CIRCUIT NO.	BRANCH CKT. BKR. POLE/AMPS	BRANCH CIRCUIT AMPS	KVA LOAD
AEP 21.L11	1	39	ELC SRV TY A 120/240 060(NS)AL(E)SP(O) US 67 AT US 259	2"	3/#6	N/A	2P/60	60	N/A	A B	2P/15 2P/15	3 3	1.4
AEP 31.L13	2	43	ELC SRV TY A 120/240 060(NS)AL(E)SP(O) US 80 AT RODEO DR.	2"	3/#6	N/A	2P/60	60	N/A	A	2P/15	2	0.5
UPSHUR RURAL 31.L14	3	46	ELC SRV TY A 120/240 060(NS)AL(E)SP(O) US 271 AT FM 726	2"	3/#6	N/A	2P/60	60	N/A	A B	2P/15 2P/15	3 3	1.4
BOWIE CASS 21.L12	4	51	ELC SRV TY A 120/240 060(NS)AL(E)SP(O) US 259 AT FM 144	2"	3/#6	N/A	2P/60	60	N/A	A B	2P/15 2P/15	6 3	2.2
BOWIE CASS 21.L13	5	57	ELC SRV TY A 120/240 060(NS)AL(E)SP(O) US 259 AT FM 3421	2"	3/#6	N/A	2P/60	60	N/A	A B	2P/15 2P/15	3 2	1.2
AEP 31.L17	6	60	ELC SRV TY A 120/240 060(NS)AL(E)SP(O) SH 155 AT FM 2911	2"	3/#6	N/A	2P/60	60	N/A	A	2P/15	3	0.7
WOOD CO. 73.L4	7	62	ELC SRV TY A 120/240 060(NS)AL(E)SP(O) FM 127 AT FM 2882	2"	3/#6	N/A	2P/60	60	N/A	A	2P/15	3	0.7
UPSHUR RURAL 33.L6	8	65	ELC SRV TY A 120/240 060(NS)AL(E)SP(O) FM 3358 AT FM 726	2"	3/#6	N/A	2P/60	60	N/A	A	2P/15	4	1.0
AEP 33.L7	9	69	ELC SRV TY A 120/240 060(NS)AL(E)SP(O) FM 1845 AT FM 1844	2"	3/#6	N/A	2P/60	60	N/A	A	2P/15	4	0.7

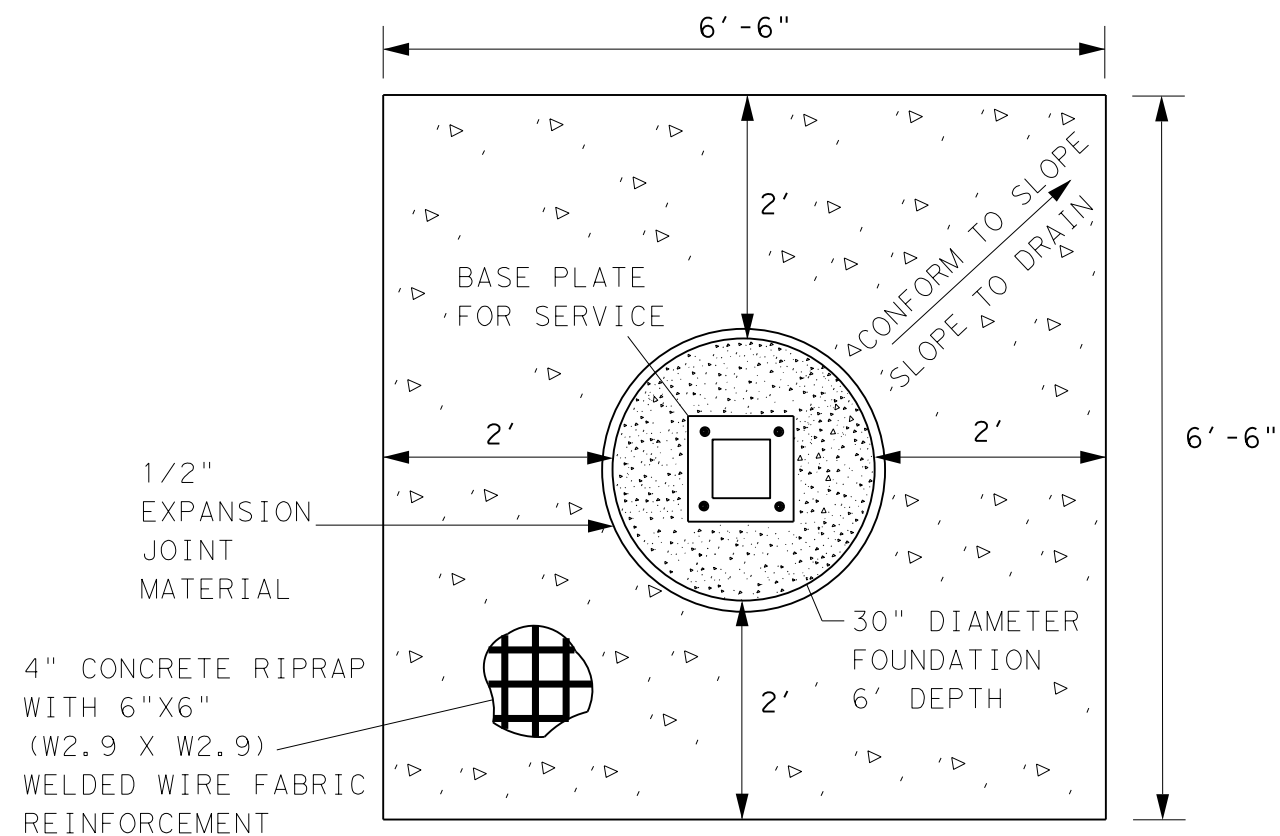

NOTES:

- 1.) PLACE CONCRETE RIP RAP APRON AROUND 30" FOUNDATION FOR ELECTRICAL SERVICE AS SHOWN IN THE DETAIL WITH A 4" DEPTH.
- 2.) USE 6"X6" W2.9 X W2.9 WELDED WIRE FABRIC FOR REINFORCEMENT.
- 3.) RIP RAP APRON WILL BE PAID FOR UNDER ITEM 432. FOUNDATION FOR ELECTRICAL SERVICE IS SUBSIDIARY TO ITEM 628 AND WILL NOT BE PAID FOR SEPERATELY. FOUNDATION DEPTH WILL BE 6'.
- 4.) RIP RAP APRON WILL CONFORM TO SLOPE OF SURROUNDING GRADE. IT IS NOT INTENDED TO BE FLAT.
- 5.) PROVIDE EXPANSION JOINT MATERIAL BETWEEN THE 30" FOUNDATION AND THE RIP RAP APRON.

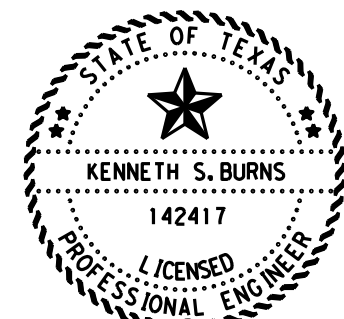

Kenneth S. Burns, P.E.

2/9/2024

ELECTRICAL SERVICE DATA WITH MODIFIED FOUNDATION AND PAD DETAIL



FHWA TEXAS DIVISION		CONSTRUCTION PROJECT NO.		SHEET NO.
				35
STATE	DISTRICT	COUNTY		
TEXAS	ATL	MORRIS		
CONTROL	SECTION	JOB	HIGHWAY NO.	
0010	08	060	US 67	

NOT TO SCALE

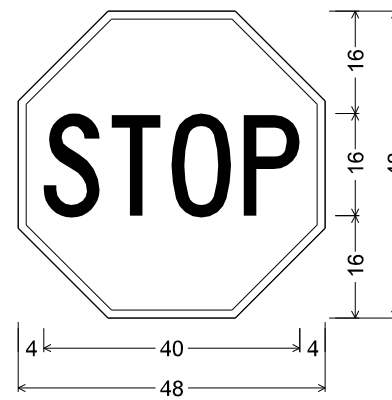

R1-1_48x48;
1.3" Border, White on Red;
"STOP", C 60% spacing;

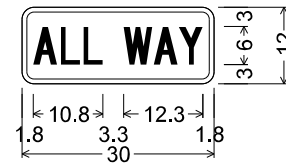

R1-3P_30x12;
1.9" Radius, 0.8" Border, White on Red;
"ALL WAY", C specified length;

32" EXTRUDED ALUMINUM WINDBEAMS

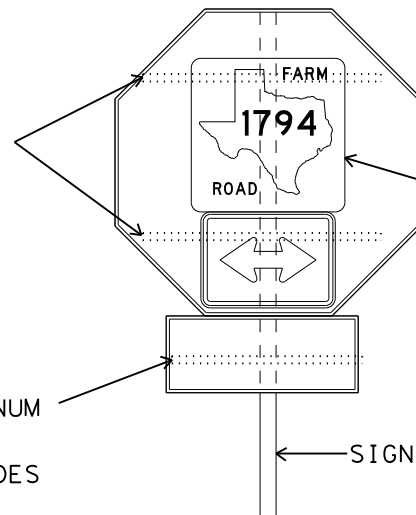

RT. MARKER MOUNTED BACKSIDE OF 48"X48" STOP SIGN.

VARIABLE EXTRUDED ALUMINUM WINDBEAM
32" FOR CROSS TRAFFIC DOES NOT STOP.
26" FOR ALL WAY

SIGN POST 10 BWG (P)

TYPICAL INSTALL FOR STOP SIGN WITH ALL WAY STOP PLAQUE

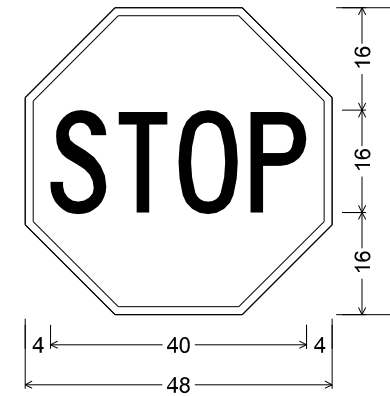

R1-1_48x48;
1.3" Border, White on Red;
"STOP", C 60% spacing;

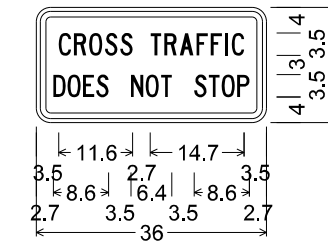

W4-4P_36x18;
2.3" Radius, 0.9" Border, 0.6" Indent, Black on Yellow;
"CROSS TRAFFIC", C 79% spacing;
"DOES NOT STOP", C 54% spacing;

32" EXTRUDED ALUMINUM WINDBEAMS

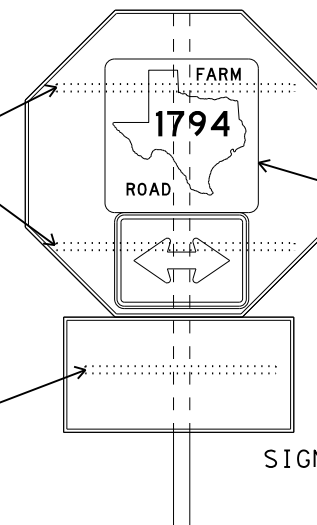

RT. MARKER MOUNTED BACKSIDE OF 48"X48" STOP SIGN.

VARIABLE EXTRUDED ALUMINUM WINDBEAM
32" FOR CROSS TRAFFIC DOES NOT STOP.
26" FOR ALL WAY

SIGN POST 10 BWG (P)

TYPICAL INSTALL FOR STOP SIGN WITH CROSS TRAFFIC DOES NOT STOP PLAQUE

NOTES:

- 1.) SOME OF THE INTERSECTIONS CALL FOR A BACK TO BACK MOUNT WITH A ROUTE MARKER MOUNTED ON THE BACKSIDE OF A STOP SIGN. MOUNT THE ROUTE MARKER SO THAT NO PART OF THE ROUTE MARKER IS SHOWING ON THE FRONT SIDE (STOP SIGN SIDE FACING ONCOMING TRAFFIC). REASON FOR THIS IS SO THAT WE DO NOT IN ANY WAY DISTORT THE OCTAGON SHAPE OF THE STOP SIGN AND CAUSE ANY CONFUSION TO THE DRIVER.
- 2.) SEE STANDARD SMD (SLIP-2)-08 INSTALL EXTRUDED ALUMINUM WIND BEAM AS SHOWN.

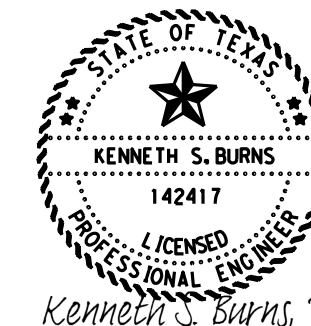

Kenneth S. Burns, P.E.

1/30/2024

NOT TO SCALE

TYPICAL INSTALLATION
BACK TO BACK
SIGN MOUNT



FHWA TEXAS DIVISION		CONSTRUCTION PROJECT NO.		SHEET NO.
				36
STATE	DISTRICT	COUNTY		
TEXAS	ATL	MORRIS		
CONTROL	SECTION	JOB	HIGHWAY NO.	
0010	08	060	US 67	

FILE: T:\engdata\Traffic\DN\192515 Jamie\JOBS\LIGHTING PROJECTS\Lighting Project May 2024\Intersections\US 259 at US 67\US 259 at US 67.dgn
 DATE: 1/25/2024 8:53:17 AM

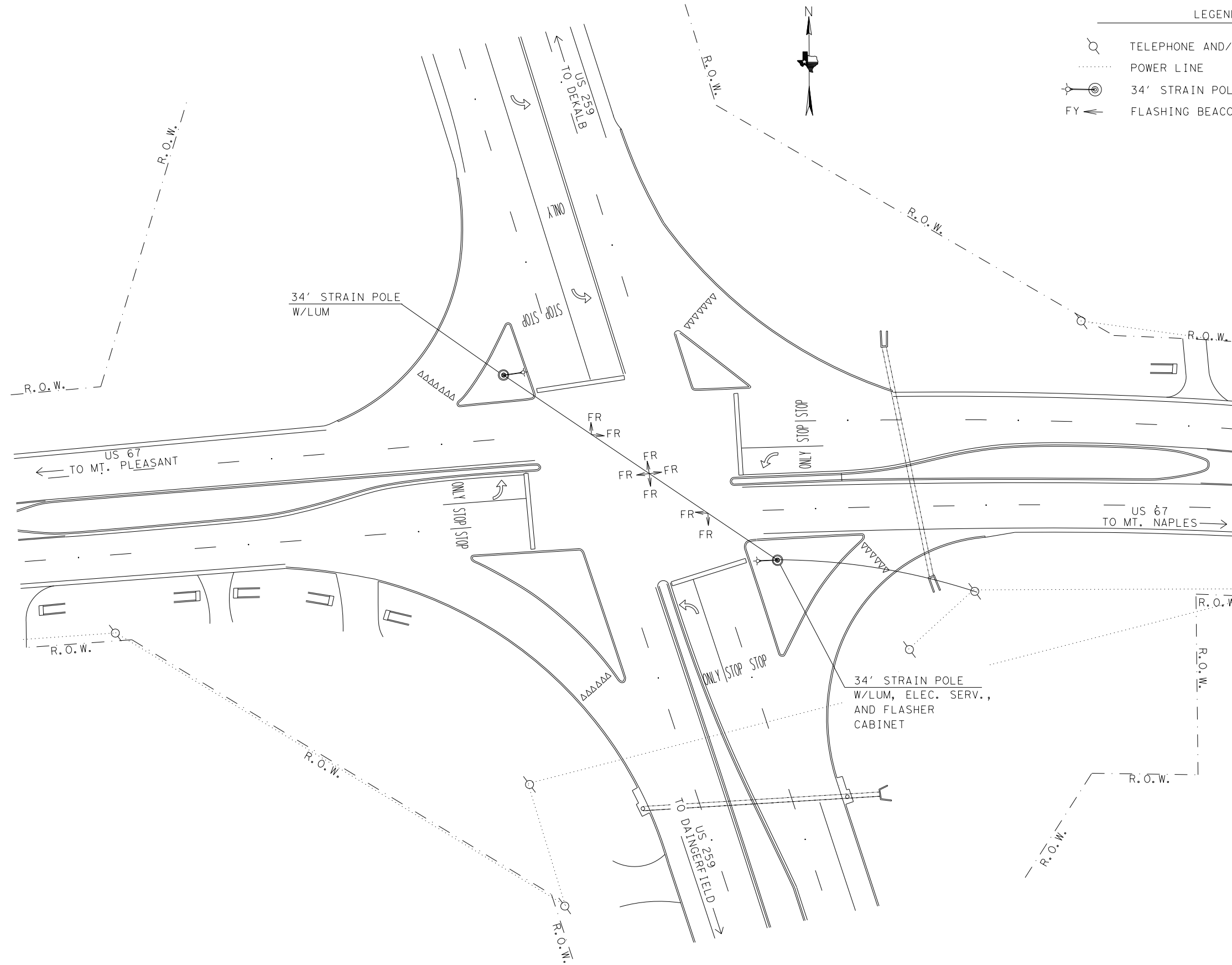

LEGEND

	TELEPHONE AND/OR POWER POLE
	POWER LINE
	34' STRAIN POLE w/ LUM
	FLASHER BEACON AND COLOR

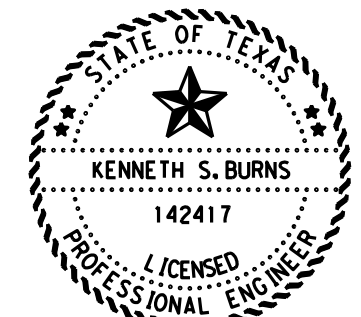

Kenneth S. Burns, P.E.

1/30/2024

**EXISTING CONDITION LAYOUT
 US 67 AT US 259**





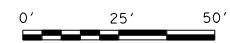









FHWA TEXAS DIVISION		CONSTRUCTION PROJECT NO.		SHEET NO.
				37
STATE	DISTRICT	COUNTY		
TEXAS	ATL	MORRIS		
CONTROL	SECTION	JOB	HIGHWAY NO.	
0010	08	060	US 67	



FILE: T:\engdata\Traffic\Traffic\Lighting\Projects\Lighting\Projects\US 259 at US 67\US 259 at US 67.dgn
 DATE: 1/25/2024 8:54:56 AM

LEGEND

-  RDWY ILL ASSEM W/RIPRAP APRON
-  GROUND BOX (TY D) (162922) W/APRON
-  GROUND BOX (TY A) (122311) W/APRON
-  GROUND BOX (TY A) (122311)
-  TRENCHED CONDUIT
-  BORED CONDUIT
-  OVERHEAD POWER LINE
-  WIRE RUN NUMBER
-  LUMINAIRE CIRCUIT & POLE NUMBER
-  ELECTRICAL SERVICE
-  TELEPHONE AND/OR POWER POLE
-  CULVERT
-  DRAINAGE PIPE

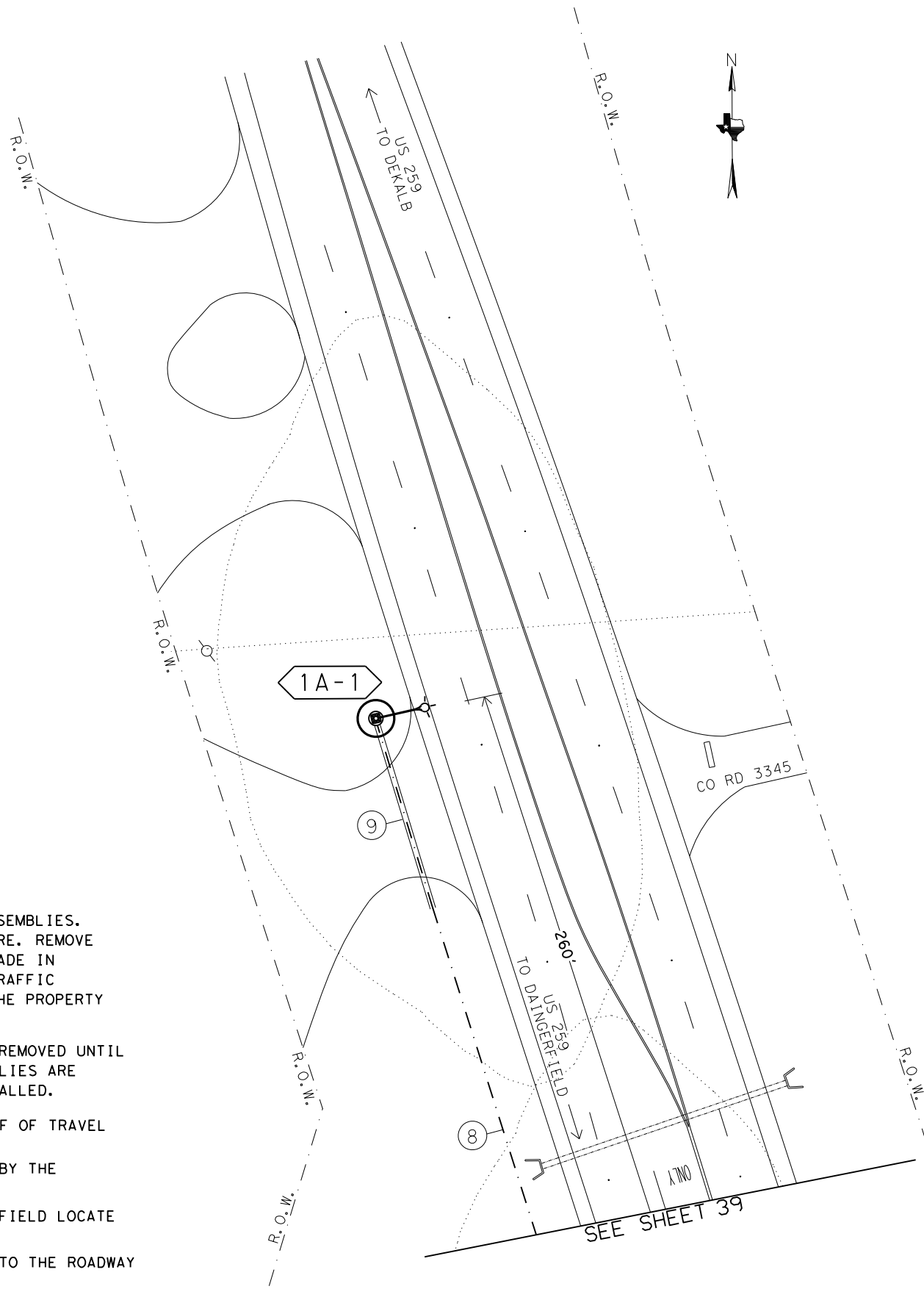

NOTE:

- 1.) INSTALL PROPOSED ROADWAY ILLUMINATION ASSEMBLIES. REMOVE EXISTING STRAIN POLES AND SPAN WIRE. REMOVE FOUNDATIONS FOR STRAIN POLES 2' BELOW GRADE IN ACCORDANCE WITH ITEM 680 6004 REMOVING TRAFFIC SIGNALS. ALL REMOVAL ITEMS WILL BECOME THE PROPERTY OF THE CONTRACTOR UPON REMOVAL.
- 2.) OVERHEAD FLASHING BEACONS ARE NOT TO BE REMOVED UNTIL THE PROPOSED ROADWAY ILLUMINATION ASSEMBLIES ARE FUNCTIONING AND PROPOSED STOP SIGNS INSTALLED.
- 3.) LUMINAIRES WILL BE INSTALLED MIN. 15' OFF OF TRAVEL LANE LINE UNLESS OTHERWISE NOTED.
- 4.) LUMINAIRE POLE LOCATIONS WILL BE STAKED BY THE CONTRACTOR AND APPROVED BY THE ENGINEER.
- 5.) IT IS THE CONTRACTORS RESPONSIBILITY TO FIELD LOCATE ALL EXISTING UTILITIES.
- 6.) LUMINAIRES WILL BE PLACED PERPENDICULAR TO THE ROADWAY AS PER DEPARTMENT REQUIREMENTS.

RUN NO.	CONDUIT 2" PVC		TYP D GROUND BOX APRON NONE	TYP A GROUND BOX APRON NONE	CONDUCTORS			
	BORED (LF)	TRENCHED (LF)			#6 INSULATED		#6 BARE	
					NO. OF CONDUCTORS	LF	NO. OF CONDUCTORS	LF
1		18	1		4	112	1	28
2	149			1	2	308	1	154
3		61			2	132	1	66
4	203			1	2	416	1	208
5		60			2	130	1	65
6	210			1	2	430	1	215
7		33			2	76	1	38
8		190			2	380	1	190
9	70				2	150	1	75
10	50				2	100	1	50
11		200			2	410	1	205
TOTALS	682	562	1	3		2644		1294

* CALCULATIONS FOR WIRE TOTALS:
 -5' OF SLACK FOR GROUND BOXES. (PER CONDUCTOR)
 -5' OF SLACK FOR WIRE IN THE SERVICE. (PER CONDUCTOR)
 -5' OF SLACK FOR WIRE IN THE BASE OF ILLUMINATION POLES. (PER CONDUCTOR)

SUMMARY OF QUANTITIES-ILLUMINATION

ITEM	DESC CODE	DESCRIPTION	UNIT	TOTAL
0416	6029	DRILL SHAFT (RDWY ILL POLE) (30 IN)	LF	60
0432	6006	RIPRAP (CONC) (CL B)	CY	3
0610	6288	IN RD IL (TY SA) 50T-10 (400W EQ) LED	EA	6
0618	6023	COND (PVC) (SCHD 40) (2")	LF	562
0618	6024	COND (PVC) (SCHD 40) (2") (BORE)	LF	682
0620	6009	ELEC CONDR (NO. 6) BARE	LF	1294
0620	6010	ELEC CONDR (NO. 6) INSULATED	LF	2644
0624	6002	GROUND BOX TY A (122311) W/APRON	EA	3
0624	6010	GROUND BOX TY D (162922) W/APRON	EA	1
0628	6004	ELC SRV TY A 120/240 060 (NS) AL (E) SP (O)	EA	1
0680	6004	REMOVING TRAFFIC SIGNALS	EA	1
6185	6002	TMA (STATIONARY)	DAY	8

ROADWAY ILLUMINATION ASSEMBLY SUMMARY

POLE	TYPE	FND. (LF)	REMARKS
1A-1	(TY SA) 50T-10 (400W EQ) LED	10	17' OFF TRAVEL LANE
1A-2	(TY SA) 50T-10 (400W EQ) LED	10	10' OFF BACK OF CURB
1A-3	(TY SA) 50T-10 (400W EQ) LED	10	13' OFF TRAVEL LANE
1B-1	(TY SA) 50T-10 (400W EQ) LED	10	10' OFF BACK OF CURB
1B-2	(TY SA) 50T-10 (400W EQ) LED	10	8' OFF BACK OF CURB
1B-3	(TY SA) 50T-10 (400W EQ) LED	10	8' OFF BACK OF CURB

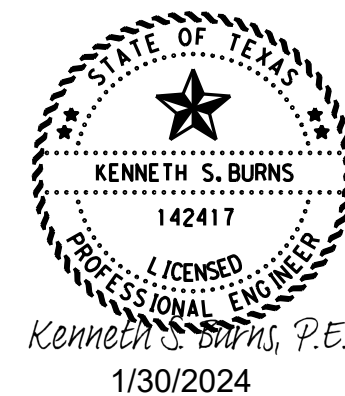

**PROPOSED ILLUMINATION LAYOUT
 US 67 AT US 259**

© 2024 Texas Department of Transportation

SHEET 10F 3

FHWA TEXAS DIVISION	CONSTRUCTION PROJECT NO.	SHEET NO.
		38
STATE	DISTRICT	COUNTY
TEXAS	ATL	MORRIS
CONTROL	SECTION	JOB HIGHWAY NO.
0010	08	060 US 67

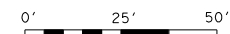

FILE: T:\engdata\Traffic\Traffic\Lighting Projects\Lighting Project May 2024\Intersections\US 259 at US 67\US 259 at US 67.dgn
 DATE: 1/25/2024 8:56:16 AM

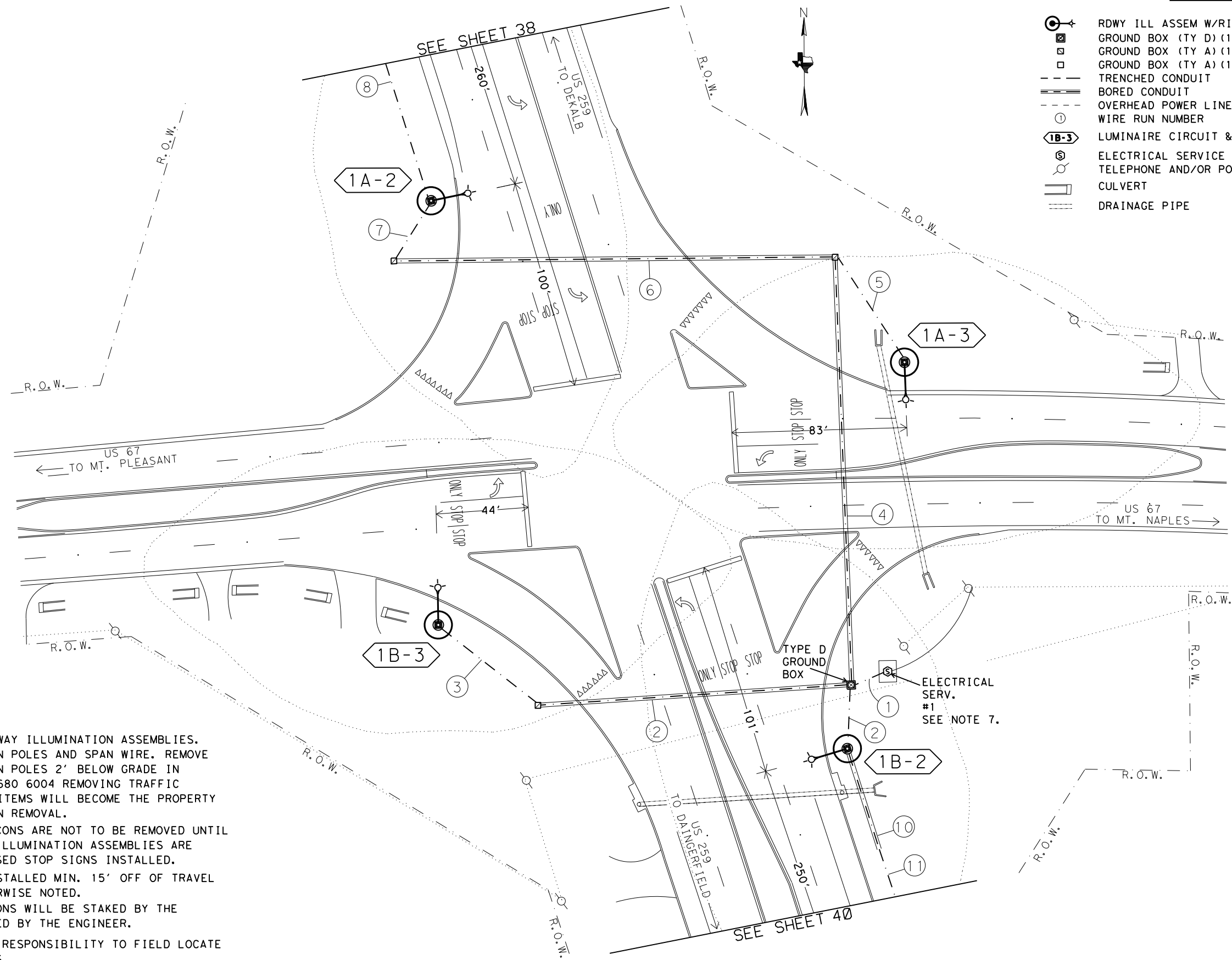

LEGEND

- RDWY ILL ASSEM W/RIPRAP APRON
- GROUND BOX (TY D) (162922) W/APRON
- GROUND BOX (TY A) (122311) W/APRON
- GROUND BOX (TY A) (122311)
- TRENCHED CONDUIT
- BORED CONDUIT
- OVERHEAD POWER LINE
- WIRE RUN NUMBER
- LUMINAIRE CIRCUIT & POLE NUMBER
- ELECTRICAL SERVICE
- TELEPHONE AND/OR POWER POLE
- CULVERT
- DRAINAGE PIPE

NOTE:

- 1.) INSTALL PROPOSED ROADWAY ILLUMINATION ASSEMBLIES. REMOVE EXISTING STRAIN POLES AND SPAN WIRE. REMOVE FOUNDATIONS FOR STRAIN POLES 2' BELOW GRADE IN ACCORDANCE WITH ITEM 680 6004 REMOVING TRAFFIC SIGNALS. ALL REMOVAL ITEMS WILL BECOME THE PROPERTY OF THE CONTRACTOR UPON REMOVAL.
- 2.) OVERHEAD FLASHING BEACONS ARE NOT TO BE REMOVED UNTIL THE PROPOSED ROADWAY ILLUMINATION ASSEMBLIES ARE FUNCTIONING AND PROPOSED STOP SIGNS INSTALLED.
- 3.) LUMINAIRES WILL BE INSTALLED MIN. 15' OFF OF TRAVEL LANE LINE UNLESS OTHERWISE NOTED.
- 4.) LUMINAIRE POLE LOCATIONS WILL BE STAKED BY THE CONTRACTOR AND APPROVED BY THE ENGINEER.
- 5.) IT IS THE CONTRACTORS RESPONSIBILITY TO FIELD LOCATE ALL EXISTING UTILITIES.
- 6.) LUMINAIRES WILL BE PLACED PERPENDICULAR TO THE ROADWAY AS PER DEPARTMENT REQUIREMENTS.
- 7.) AEP TO CUT TREE LIMBS FOR LATERAL TO PROPOSED SERVICE.

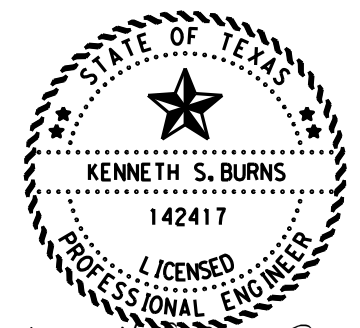

Kenneth S. Burns, P.E.

1/30/2024

**PROPOSED ILLUMINATION LAYOUT
 US 67 AT US 259**





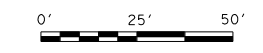







© 2024 Texas Department of Transportation
 SHEET 2 OF 3

FHWA TEXAS DIVISION		CONSTRUCTION PROJECT NO.		SHEET NO.	
				39	
STATE	DISTRICT	COUNTY			
TEXAS	ATL	MORRIS			
CONTROL	SECTION	JOB	HIGHWAY NO.		
0010	08	060	US 67		



FILE: T:\engdata\Traffic\DGN\192515 Jamie\JOBS\LIGHTING PROJECTS\Lighting Project May 2024\Intersections\US 259 at US 67\US 259 at US 67.dgn
 DATE: 1/25/2024 8:57:18 AM

LEGEND

-  RDWY ILL ASSEM W/RIPRAP APRON
-  GROUND BOX (TY D) (162922) W/APRON
-  GROUND BOX (TY A) (122311) W/APRON
-  GROUND BOX (TY A) (122311)
-  TRENCHED CONDUIT
-  BORED CONDUIT
-  OVERHEAD POWER LINE
-  WIRE RUN NUMBER
-  LUMINAIRE CIRCUIT & POLE NUMBER
-  ELECTRICAL SERVICE
-  TELEPHONE AND/OR POWER POLE
-  CULVERT
-  DRAINAGE PIPE

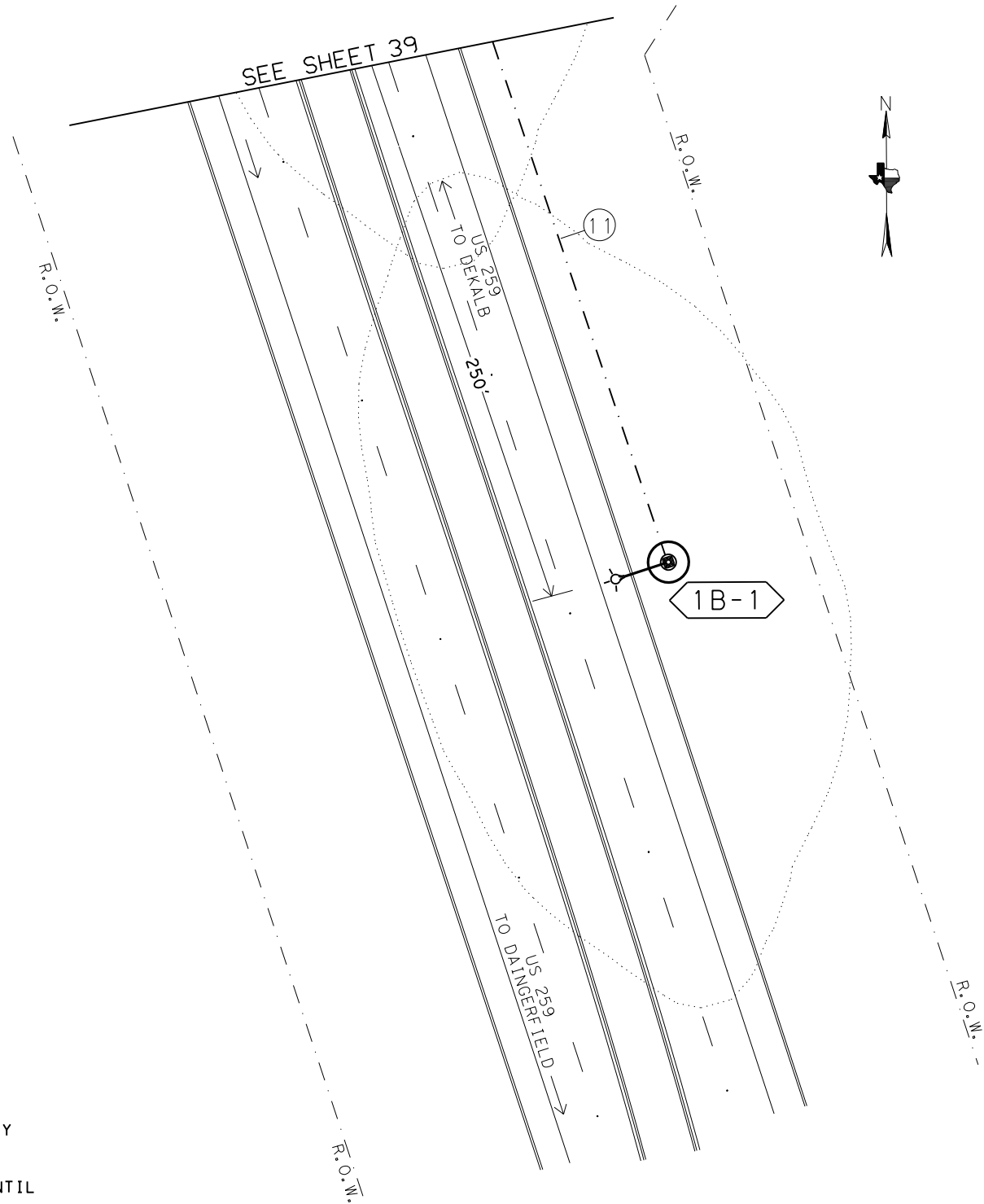

NOTE:

- 1.) INSTALL PROPOSED ROADWAY ILLUMINATION ASSEMBLIES. REMOVE EXISTING STRAIN POLES AND SPAN WIRE. REMOVE FOUNDATIONS FOR STRAIN POLES 2' BELOW GRADE IN ACCORDANCE WITH ITEM 680 6004 REMOVING TRAFFIC SIGNALS. ALL REMOVAL ITEMS WILL BECOME THE PROPERTY OF THE CONTRACTOR UPON REMOVAL.
- 2.) OVERHEAD FLASHING BEACONS ARE NOT TO BE REMOVED UNTIL THE PROPOSED ROADWAY ILLUMINATION ASSEMBLIES ARE FUNCTIONING AND PROPOSED STOP SIGNS INSTALLED.
- 3.) LUMINAIRES WILL BE INSTALLED MIN. 15' OFF OF TRAVEL LANE LINE UNLESS OTHERWISE NOTED.
- 4.) LUMINAIRE POLE LOCATIONS WILL BE STAKED BY THE CONTRACTOR AND APPROVED BY THE ENGINEER.
- 5.) IT IS THE CONTRACTORS RESPONSIBILITY TO FIELD LOCATE ALL EXISTING UTILITIES.
- 6.) LUMINAIRES WILL BE PLACED PERPENDICULAR TO THE ROADWAY AS PER DEPARTMENT REQUIREMENTS.

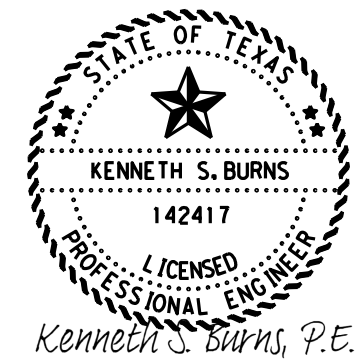

1/30/2024

**PROPOSED
ILLUMINATION
LAYOUT
US 67 AT US 259**

© 2024 Texas Department of Transportation
SHEET 3 OF 3

FHWA TEXAS DIVISION		CONSTRUCTION PROJECT NO.		SHEET NO.	
				40	
STATE	DISTRICT	COUNTY			
TEXAS	ATL	MORRIS			
CONTROL	SECTION	JOB	HIGHWAY NO.		
0010	08	060	US 67		

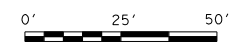

FILE: T:\engdata\Traffic\DN\192515 Jamie\JOBS\LIGHTING PROJECTS\Lighting Project May 2024\Intersections\US 259 at US 67\US 259 at US 67.dgn
 DATE: 1/25/2024 8:57:56 AM

LEGEND

- [E] EXISTING SIGN TO BE REMOVED
- [P] PROPOSED SIGN
- (A) PREFAB PAV MRK TY C (W) (24") (SLD)
- (B) PREFAB PAV MRK TY C (W) (ARROW)
- (C) PREFAB PAV MRK TY C (W) (WORD)
- (D) PREFAB PAV MRK TY C (W) (36") (YLD TRI)
- (E) PREFORMED IN-LANE (TRANS) RUMBLE STRIP

EXISTING STOP AHEAD BEACON (SEE NOTE 3.)

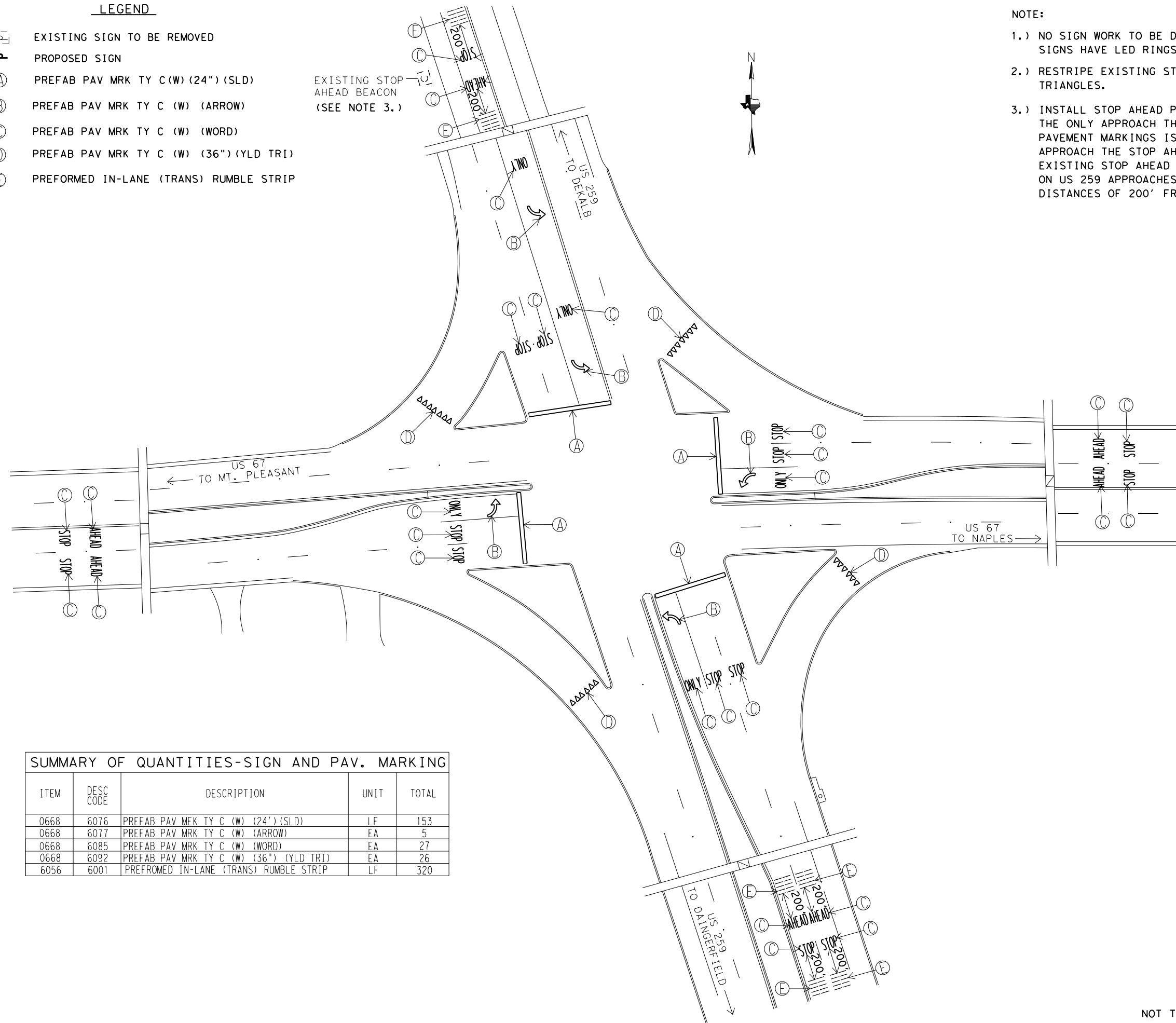

NOTE:

- 1.) NO SIGN WORK TO BE DONE AT THIS INTERSECTION ALL STOP SIGNS HAVE LED RINGS. THE STOP AHEAD SIGNS HAVE BEACONS.
- 2.) RESTRIPE EXISTING STOP BARS, ARROWS, WORDS, AND YIELD TRIANGLES.
- 3.) INSTALL STOP AHEAD PAVEMENT MARKINGS AT EXISTING MARKINGS. THE ONLY APPROACH THAT CURRENTLY DOES NOT HAVE STOP AHEAD PAVEMENT MARKINGS IS US 259 SOUTHBOUND APPROACH. FOR THIS APPROACH THE STOP AHEAD MARKINGS WILL BE PLACED AT THE EXISTING STOP AHEAD BEACON. INSTALL TRANSVERSE RUMBLE STRIPS ON US 259 APPROACHES. INSTALL TRANSVERSE RUMBLE STRIPS AT DISTANCES OF 200' FROM MARKINGS AS SHOWN.

SUMMARY OF QUANTITIES-SIGN AND PAV. MARKING

ITEM	DESC CODE	DESCRIPTION	UNIT	TOTAL
0668	6076	PREFAB PAV MRK TY C (W) (24") (SLD)	LF	153
0668	6077	PREFAB PAV MRK TY C (W) (ARROW)	EA	5
0668	6085	PREFAB PAV MRK TY C (W) (WORD)	EA	27
0668	6092	PREFAB PAV MRK TY C (W) (36") (YLD TRI)	EA	26
6056	6001	PREFORMED IN-LANE (TRANS) RUMBLE STRIP	LF	320

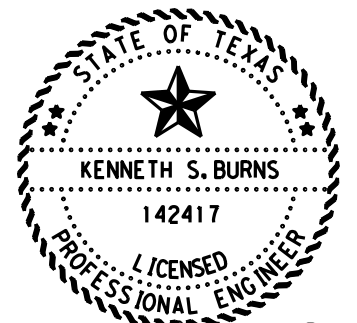

Kenneth S. Burns, P.E.

1/30/2024







PROPOSED SIGN AND PAVEMENT MARKING LAYOUT US 67 AT US 259

© 2024 Texas Department of Transportation

FHWA TEXAS DIVISION		CONSTRUCTION PROJECT NO.		SHEET NO.
				41
STATE	DISTRICT	COUNTY		
TEXAS	ATL	MORRIS		
CONTROL	SECTION	JOB	HIGHWAY NO.	
0010	08	060	US 67	

NOT TO SCALE

FILE: T:\engdata\Traffic\DGN\192515 Jamie\JOBS\LIGHTING PROJECTS\Lighting Project May 2024\Intersections\US 80 at Rodeo Dr\US 80 at Rodeo Dr.dgn
 DATE: 1/25/2024 8:59:44 AM

- LEGEND
-  TELEPHONE AND/OR POWER POLE
 -  POWER LINE
 -  34' STRAIN POLE w/ LUM
 -  FLASHING BEACON AND COLOR
 -  CULVERT
 -  DRAINAGE PIPE
 -  RXR SIGNAL CABIN

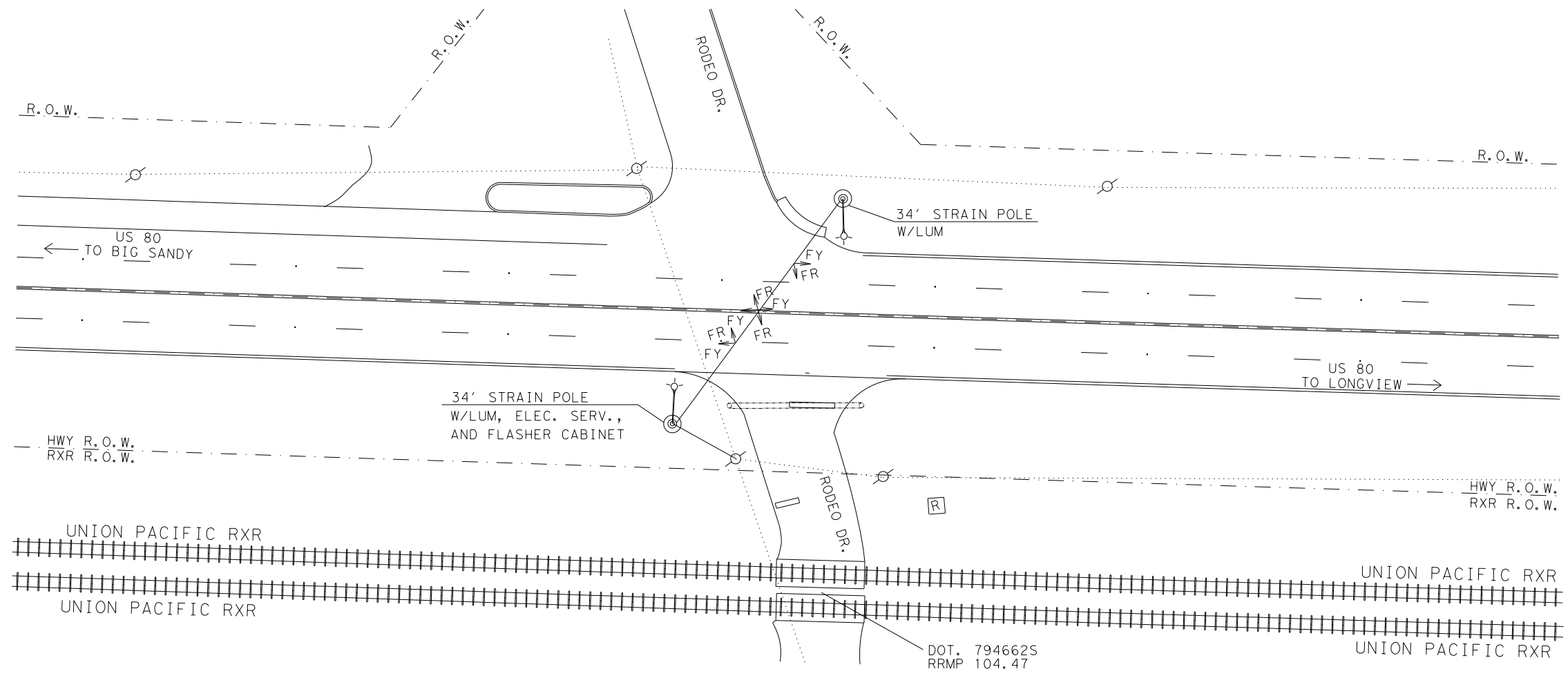
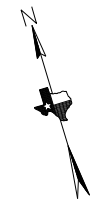

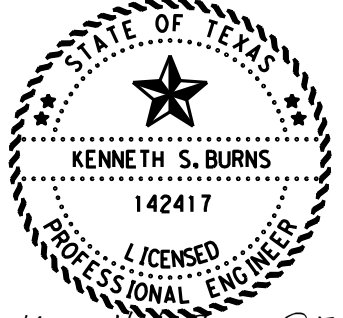
 KENNETH S. BURNS
 142417
 LICENSED
 PROFESSIONAL ENGINEER
 Kenneth S. Burns, P.E.
 1/30/2024

**EXISTING CONDITION
 LAYOUT
 US 80 AT RODEO DR.**

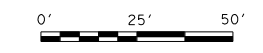

FHWA TEXAS DIVISION		CONSTRUCTION PROJECT NO.		SHEET NO.
				42
STATE	DISTRICT	COUNTY		
TEXAS	ATL	MORRIS		
CONTROL	SECTION	JOB	HIGHWAY NO.	
0010	08	060	US 67	

FILE: T:\engdata\Traffic\NGN\192515 Jamie\JOBS\LIGHTING PROJECTS\Lighting Project May 2024\Intersections\US 80 at Rodeo Dr\US 80 at Rodeo Dr.dgn
 DATE: 1/25/2024 9:01:01 AM

LEGEND

- RDWY ILL ASSEM W/RIPRAP APRON
- GROUND BOX (TY D) (162922) W/APRON
- GROUND BOX (TY A) (122311) W/APRON
- GROUND BOX (TY A) (122311)
- TRENCHED CONDUIT
- BORED CONDUIT
- OVERHEAD POWER LINE
- WIRE RUN NUMBER
- LUMINAIRE CIRCUIT & POLE NUMBER
- ELECTRICAL SERVICE
- TELEPHONE AND/OR POWER POLE
- CULVERT
- DRAINAGE PIPE

ROADWAY ILLUMINATION ASSEMBLY SUMMARY			
POLE	TYPE	FND. (LF)	REMARKS
2A-1	(TY SA)50T-10(400W EQ)LED	10	15' OFF TRAVEL LANE
2A-2	(TY SA)50T-10(400W EQ)LED	10	17' OFF TRAVEL LANE

NOTE:

- 1.) INSTALL PROPOSED ROADWAY ILLUMINATION ASSEMBLIES. REMOVE EXISTING STRAIN POLES AND SPAN WIRE. REMOVE FOUNDATIONS FOR STRAIN POLES 2' BELOW GRADE IN ACCORDANCE WITH ITEM 680 6004 REMOVING TRAFFIC SIGNALS. ALL REMOVAL ITEMS WILL BECOME THE PROPERTY OF THE CONTRACTOR UPON REMOVAL.
- 2.) OVERHEAD FLASHING BEACONS ARE NOT TO BE REMOVED UNTIL THE PROPOSED ROADWAY ILLUMINATION ASSEMBLIES ARE FUNCTIONING.
- 3.) LUMINAIRES WILL BE INSTALLED MIN. 15' OFF OF TRAVEL LANE LINE UNLESS OTHERWISE NOTED.
- 4.) LUMINAIRE POLE LOCATIONS WILL BE STAKED BY THE CONTRACTOR AND APPROVED BY THE ENGINEER.
- 5.) IT IS THE CONTRACTORS RESPONSIBILITY TO FIELD LOCATE ALL EXISTING UTILITIES.

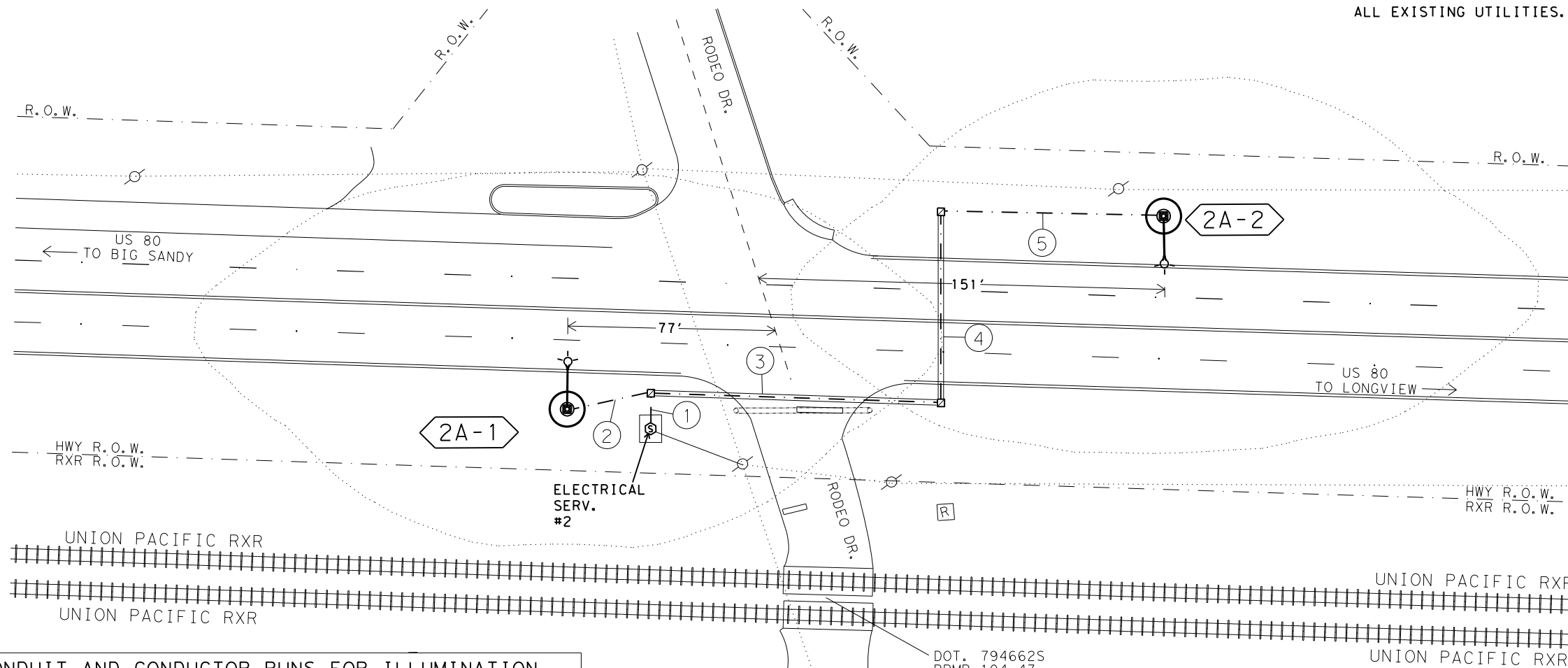

CONDUIT AND CONDUCTOR RUNS FOR ILLUMINATION								
RUN NO.	CONDUIT 2" PVC		TYP D GROUND BOX	TYP A GROUND BOX	CONDUCTORS			
	BORED (LF)	TRENCHED (LF)			#6 INSULATED		#6 BARE	
					NO. OF CONDUCTORS	LF	NO. OF CONDUCTORS	LF
1		13		1	2	46	1	23
2		32			2	64	1	32
3	108			1	2	216	1	108
4	72			1	2	154	1	77
5		83			2	176	1	88
TOTALS	180	128		3		656		328

* CALCULATIONS FOR WIRE TOTALS:
 -5' OF SLACK FOR GROUND BOXES. (PER CONDUCTOR)
 -5' OF SLACK FOR WIRE IN THE SERVICE. (PER CONDUCTOR)
 -5' OF SLACK FOR WIRE IN THE BASE OF ILLUMINATION POLES. (PER CONDUCTOR)

SUMMARY OF QUANTITIES-ILLUMINATION				
ITEM	DESC CODE	DESCRIPTION	UNIT	TOTAL
0416	6029	DRILL SHAFT (RDWY ILL POLE) (30 IN)	LF	20
0432	6006	RIPRAP (CONC) (CL B)	CY	2
0610	6288	IN RD IL (TY SA)50T-10(400W EQ)LED	EA	2
0618	6023	CONDT (PVC) (SCHD 40) (2")	LF	128
0618	6024	CONDT (PVC) (SCHD 40) (2") (BORE)	LF	180
0620	6009	ELEC CONDR (NO. 6) BARE	LF	328
0620	6010	ELEC CONDR (NO. 6) INSULATED	LF	656
0624	6002	GROUND BOX TY A (122311) W/APRON	EA	3
0628	6004	ELC SRV TY A 120/240 060 (NS) AL (E) SP (O)	EA	1
0680	6004	REMOVING TRAFFIC SIGNALS	EA	1
6185	6002	TMA (STATIONARY)	DAY	8

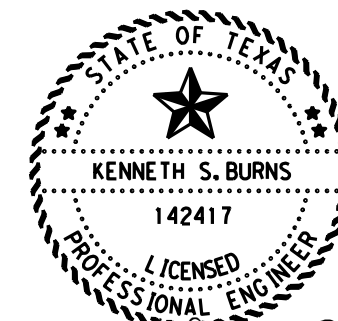

Kenneth S. Burns, P.E.

1/30/2024

PROPOSED ILLUMINATION LAYOUT US 80 AT RODEO DR.

© 2024 Texas Department of Transportation



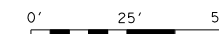

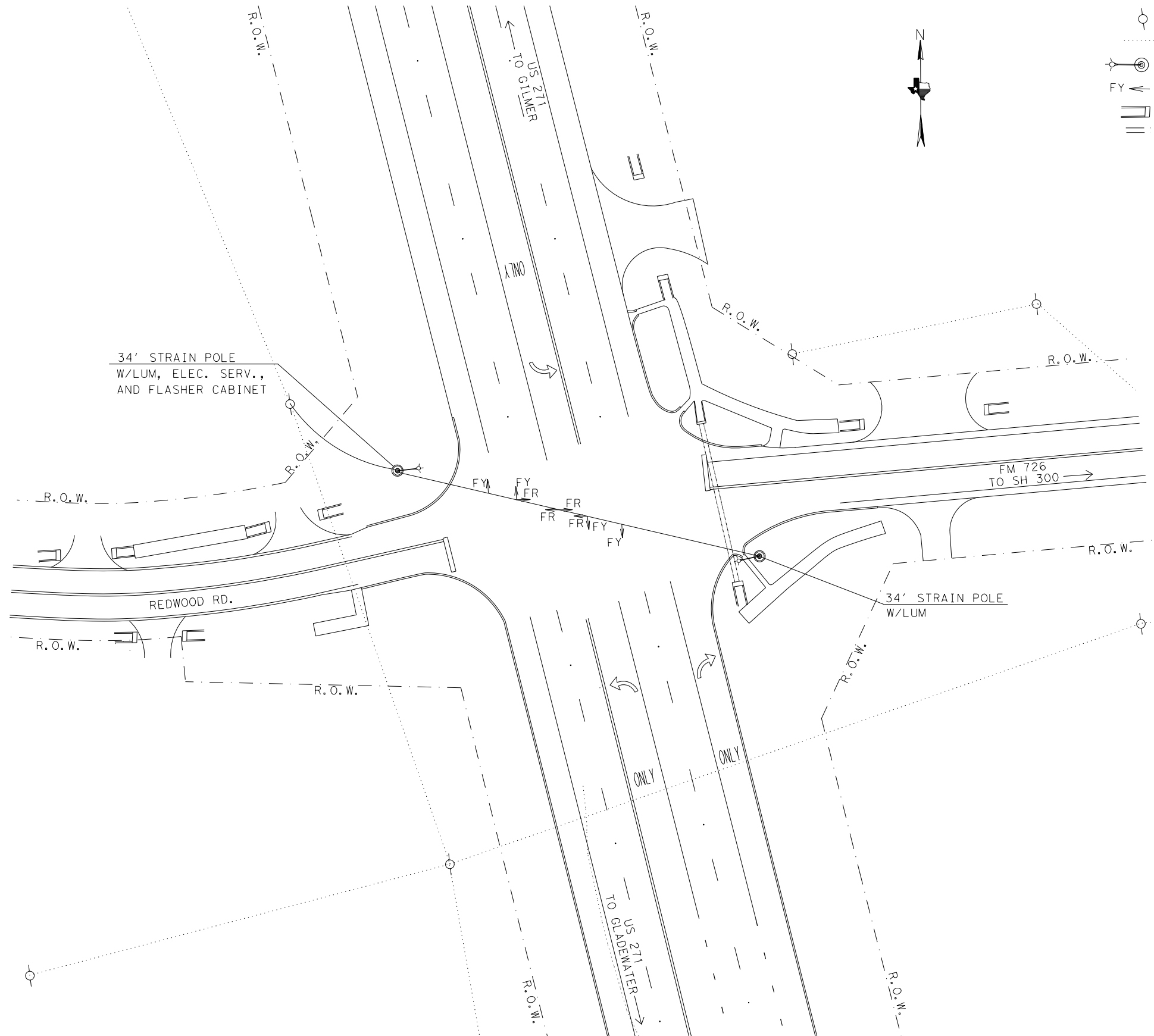

FHWA TEXAS DIVISION		CONSTRUCTION PROJECT NO.		SHEET NO.
				43
STATE	DISTRICT	COUNTY		
TEXAS	ATL	MORRIS		
CONTROL	SECTION	JOB	HIGHWAY NO.	
0010	08	060	US 67	



FILE: T:\engdata\Traffic\DN\192515_Jamie\JOBS\LIGHTING PROJECTS\Lighting Project May 2024\Intersections\US 271 at FM 726.dgn
 DATE: 1/25/2024 9:01:56 AM



LEGEND

-  TELEPHONE AND/OR POWER POLE
-  POWER LINE
-  34' STRAIN POLE w/ LUM
-  FLASHING BEACON AND COLOR
-  CULVERT
-  DRAINAGE PIPE

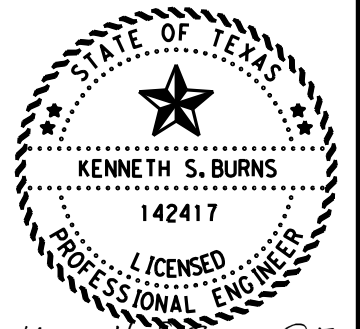

Kenneth S. Burns, P.E.
 1/30/2024

**EXISTING CONDITION
 LAYOUT
 US 271 AT FM 726**



FHWA TEXAS DIVISION		CONSTRUCTION PROJECT NO.		SHEET NO.
				44
STATE	DISTRICT	COUNTY		
TEXAS	ATL	MORRIS		
CONTROL	SECTION	JOB	HIGHWAY NO.	
0010	08	060	US 67	

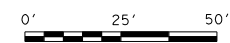

FILE: T:\engdata\Traffic\NGN\192515 Jamie\JOBS\LIGHTING PROJECTS\Lighting Project May 2024\Intersections\US 271 at FM 726\US 271 at FM 726.dgn
 DATE: 1/25/2024 9:03:27 AM

SUMMARY OF QUANTITIES-ILLUMINATION				
ITEM	DESC CODE	DESCRIPTION	UNIT	TOTAL
0416	6029	DRILL SHAFT (RDWY ILL POLE) (30 IN)	LF	50
0432	6006	RIPRAP (CONC) (CL B)	CY	3
0610	6288	IN RD IL (TY SA) 50T-10 (400W EQ) LED	EA	5
0618	6023	CONDT (PVC) (SCHD 40) (2")	LF	658
0618	6024	CONDT (PVC) (SCHD 40) (2") (BORE)	LF	409
0620	6009	ELEC CONDR (NO. 6) BARE	LF	1117
0620	6010	ELEC CONDR (NO. 6) INSULATED	LF	2284
0624	6002	GROUND BOX TY A (122311) W/APRON	EA	4
0628	6004	ELC SRV TY A 120/240 060 (NS) AL (E) SP (O)	EA	1
0680	6004	REMOVING TRAFFIC SIGNALS	EA	1
6185	6002	TMA (STATIONARY)	DAY	8

RUN NO.	CONDUIT 2" PVC		TYP D GROUND BOX	TYP A GROUND BOX	CONDUCTORS				
	BORED (LF)	TRENCHED (LF)			#6 INSULATED		#6 BARE		
			APRON NONE	APRON NONE	NO. OF CONDUCTORS	LF	NO. OF CONDUCTORS	LF	
1		15		1		4	100	1	25
2		94				2	198	1	99
3		250				2	510	1	255
4	112			1		2	234	1	117
5	57			1		2	124	1	62
6	62					2	134	1	67
7	123			1		2	256	1	128
8		104				2	218	1	109
9		195				2	390	1	195
10	55					2	120	1	60
TOTALS	409	658		4			2284		1117

* CALCULATIONS FOR WIRE TOTALS:
 -5' OF SLACK FOR GROUND BOXES. (PER CONDUCTOR)
 -5' OF SLACK FOR WIRE IN THE SERVICE. (PER CONDUCTOR)
 -5' OF SLACK FOR WIRE IN THE BASE OF ILLUMINATION POLES. (PER CONDUCTOR)

NOTE:

- 1.) INSTALL PROPOSED ROADWAY ILLUMINATION ASSEMBLIES. REMOVE EXISTING STRAIN POLES AND SPAN WIRE. REMOVE FOUNDATIONS FOR STRAIN POLES 2' BELOW GRADE IN ACCORDANCE WITH ITEM 680 6004 REMOVING TRAFFIC SIGNALS. ALL REMOVAL ITEMS WILL BECOME THE PROPERTY OF THE CONTRACTOR UPON REMOVAL.
- 2.) OVERHEAD FLASHING BEACONS ARE NOT TO BE REMOVED UNTIL THE PROPOSED ROADWAY ILLUMINATION ASSEMBLIES ARE FUNCTIONING AND PROPOSED STOP SIGNS INSTALLED.
- 3.) LUMINAIRES WILL BE INSTALLED MIN. 15' OFF OF TRAVEL LANE LINE UNLESS OTHERWISE NOTED.
- 4.) LUMINAIRE POLE LOCATIONS WILL BE STAKED BY THE CONTRACTOR AND APPROVED BY THE ENGINEER.
- 5.) IT IS THE CONTRACTORS RESPONSIBILITY TO FIELD LOCATE ALL EXISTING UTILITIES.
- 6.) LUMINAIRES WILL BE PLACED PERPENDICULAR TO THE ROADWAY AS PER DEPARTMENT REQUIREMENTS.

LEGEND

- RDWY ILL ASSEM W/RIPRAP APRON
- GROUND BOX (TY D) (162922) W/APRON
- GROUND BOX (TY A) (122311) W/APRON
- GROUND BOX (TY A) (122311)
- TRENCHED CONDUIT
- BORED CONDUIT
- OVERHEAD POWER LINE
- WIRE RUN NUMBER
- LUMINAIRE CIRCUIT & POLE NUMBER
- ELECTRICAL SERVICE
- TELEPHONE AND/OR POWER POLE
- CULVERT
- DRAINAGE PIPE

ROADWAY ILLUMINATION ASSEMBLY SUMMARY			
POLE	TYPE	FND. (LF)	REMARKS
3A-1	(TY SA) 50T-10 (400W EQ) LED	10	18' OFF TRAVEL LANE
3A-2	(TY SA) 50T-10 (400W EQ) LED	10	18' OFF TRAVEL LANE
3B-1	(TY SA) 50T-10 (400W EQ) LED	10	7' OFF BACK OF CURB
3B-2	(TY SA) 50T-10 (400W EQ) LED	10	7' OFF BACK OF CURB
3B-3	(TY SA) 50T-10 (400W EQ) LED	10	7' OFF BACK OF CURB

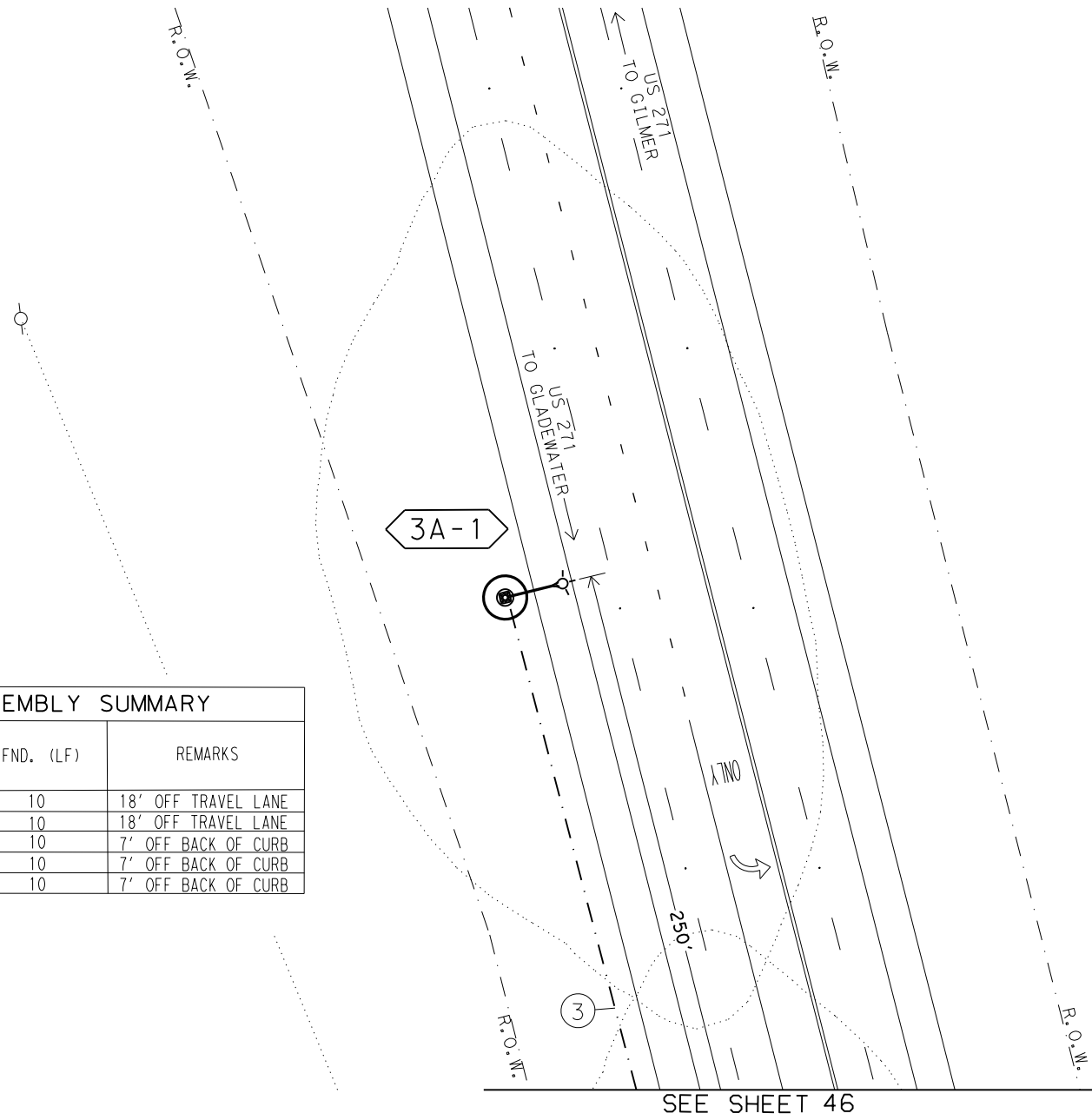

STATE OF TEXAS
 KENNETH S. BURNS
 142417
 LICENSED PROFESSIONAL ENGINEER
 Kenneth S. Burns, P.E.
 1/30/2024

PROPOSED ILLUMINATION LAYOUT
 US 271 AT FM 726

© 2024 Texas Department of Transportation

SHEET 10F 3		SHEET NO. 45	
STATE	DISTRICT	COUNTY	
TEXAS	ATL	MORRIS	
CONTROL	SECTION	JOB	HIGHWAY NO.
0010	08	060	US 67

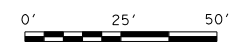

FILE: T:\engdata\Traffic\DN\192515 Jamie\JOBS\LIGHTING PROJECTS\Lighting Project May 2024\Intersections\US 271 at FM 726.dgn
 DATE: 1/25/2024 9:04:35 AM

LEGEND

	RDWY ILL ASSEM W/RIPRAP APRON
	GROUND BOX (TY D) (162922) W/APRON
	GROUND BOX (TY A) (122311) W/APRON
	GROUND BOX (TY A) (122311)
	TRENCHED CONDUIT
	BORED CONDUIT
	OVERHEAD POWER LINE
	WIRE RUN NUMBER
	LUMINAIRE CIRCUIT & POLE NUMBER
	ELECTRICAL SERVICE
	TELEPHONE AND/OR POWER POLE
	CULVERT
	DRAINAGE PIPE

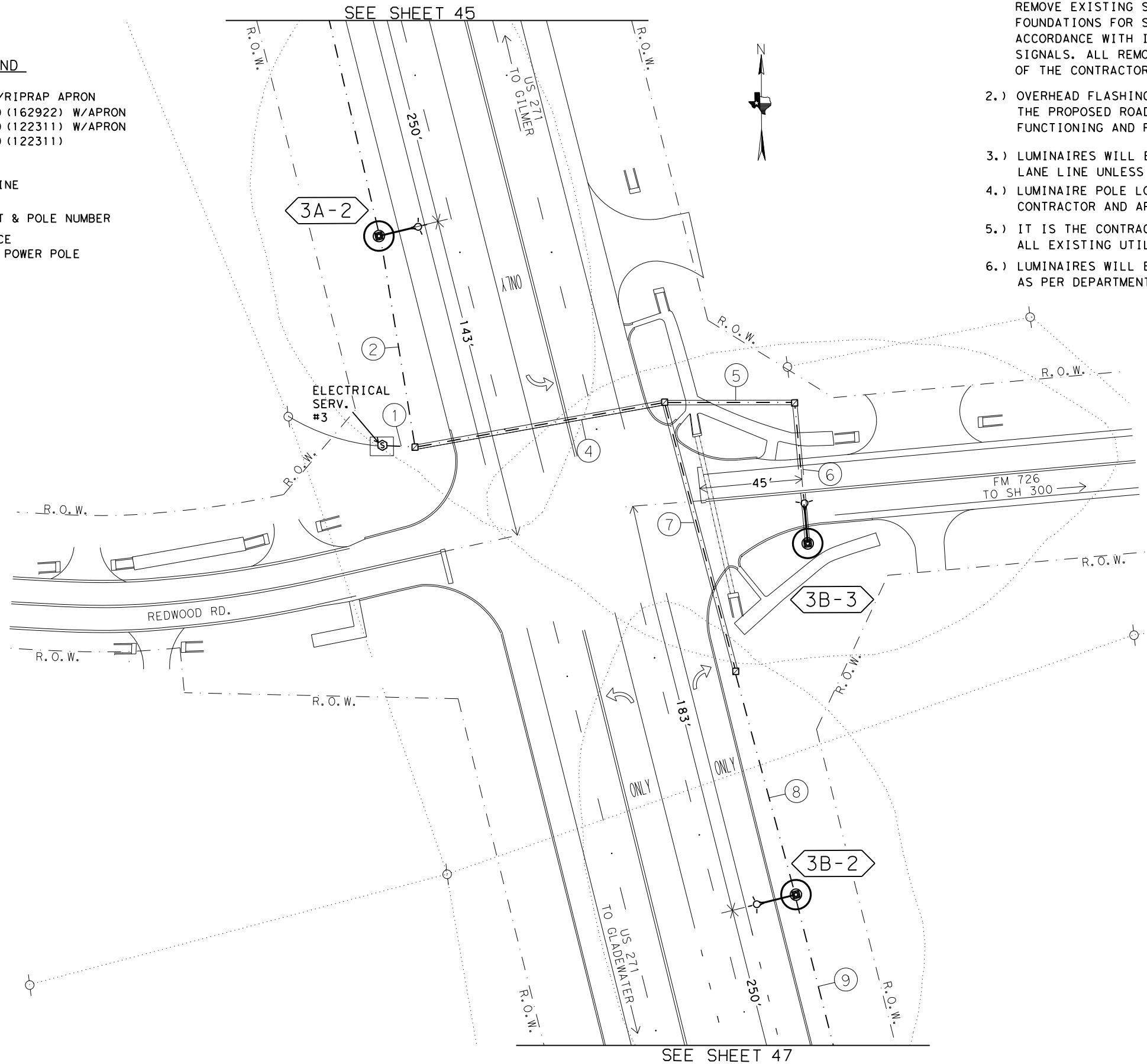

NOTE:

- 1.) INSTALL PROPOSED ROADWAY ILLUMINATION ASSEMBLIES. REMOVE EXISTING STRAIN POLES AND SPAN WIRE. REMOVE FOUNDATIONS FOR STRAIN POLES 2' BELOW GRADE IN ACCORDANCE WITH ITEM 680 6004 REMOVING TRAFFIC SIGNALS. ALL REMOVAL ITEMS WILL BECOME THE PROPERTY OF THE CONTRACTOR UPON REMOVAL.
- 2.) OVERHEAD FLASHING BEACONS ARE NOT TO BE REMOVED UNTIL THE PROPOSED ROADWAY ILLUMINATION ASSEMBLIES ARE FUNCTIONING AND PROPOSED STOP SIGNS INSTALLED.
- 3.) LUMINAIRES WILL BE INSTALLED MIN. 15' OFF OF TRAVEL LANE LINE UNLESS OTHERWISE NOTED.
- 4.) LUMINAIRE POLE LOCATIONS WILL BE STAKED BY THE CONTRACTOR AND APPROVED BY THE ENGINEER.
- 5.) IT IS THE CONTRACTORS RESPONSIBILITY TO FIELD LOCATE ALL EXISTING UTILITIES.
- 6.) LUMINAIRES WILL BE PLACED PERPENDICULAR TO THE ROADWAY AS PER DEPARTMENT REQUIREMENTS.

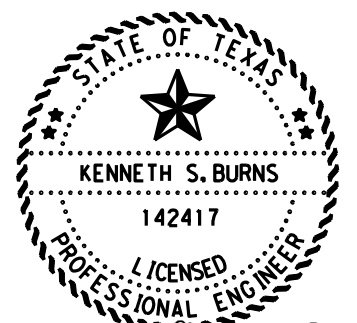

Kenneth S. Burns, P.E.

1/30/2024

**PROPOSED
 ILLUMINATION
 LAYOUT
 US 271 AT FM 726**

© 2024 Texas Department of Transportation
 SHEET 2 OF 3

FHWA TEXAS DIVISION		CONSTRUCTION PROJECT NO.		SHEET NO.	
				46	
STATE	DISTRICT	COUNTY			
TEXAS	ATL	MORRIS			
CONTROL	SECTION	JOB	HIGHWAY NO.		
0010	08	060	US 67		

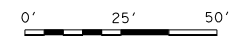

SEE SHEET 47

SEE SHEET 45

FILE: T:\engdata\Traffic\DGN\192515_Jamie\JOBS\LIGHTING PROJECTS\Lighting Project May 2024\Intersections\US 271 at FM 726.dgn
 DATE: 1/25/2024 9:05:25 AM

LEGEND

	RDWY ILL ASSEM W/RIPRAP APRON
	GROUND BOX (TY D) (162922) W/APRON
	GROUND BOX (TY A) (122311) W/APRON
	GROUND BOX (TY A) (122311)
	TRENCHED CONDUIT
	BORED CONDUIT
	OVERHEAD POWER LINE
	WIRE RUN NUMBER
	LUMINAIRE CIRCUIT & POLE NUMBER
	ELECTRICAL SERVICE
	TELEPHONE AND/OR POWER POLE
	CULVERT
	DRAINAGE PIPE

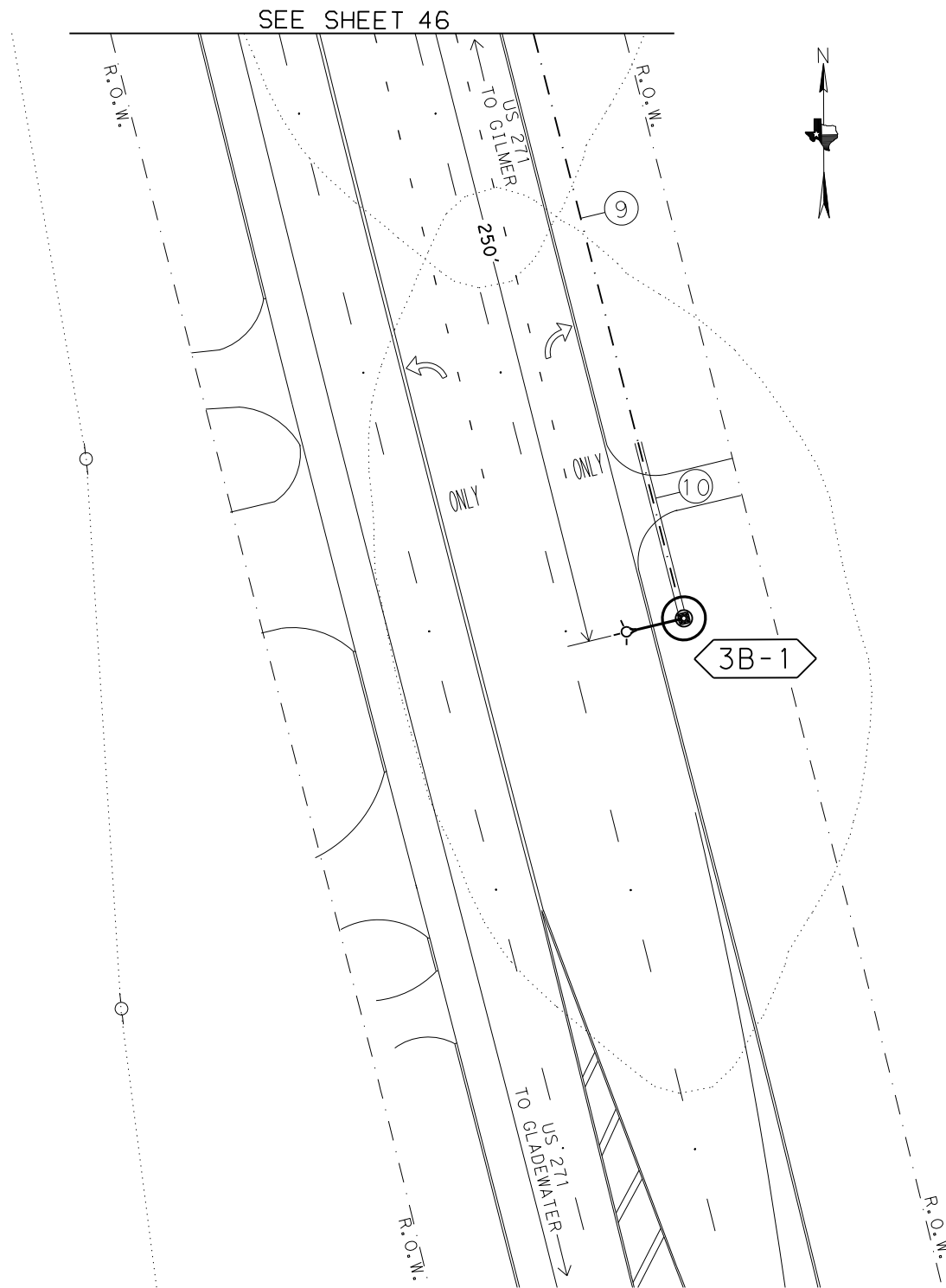

NOTE:

- 1.) INSTALL PROPOSED ROADWAY ILLUMINATION ASSEMBLIES. REMOVE EXISTING STRAIN POLES AND SPAN WIRE. REMOVE FOUNDATIONS FOR STRAIN POLES 2' BELOW GRADE IN ACCORDANCE WITH ITEM 680 6004 REMOVING TRAFFIC SIGNALS. ALL REMOVAL ITEMS WILL BECOME THE PROPERTY OF THE CONTRACTOR UPON REMOVAL.
- 2.) OVERHEAD FLASHING BEACONS ARE NOT TO BE REMOVED UNTIL THE PROPOSED ROADWAY ILLUMINATION ASSEMBLIES ARE FUNCTIONING AND PROPOSED STOP SIGNS INSTALLED.
- 3.) LUMINAIRES WILL BE INSTALLED MIN. 15' OFF OF TRAVEL LANE LINE UNLESS OTHERWISE NOTED.
- 4.) LUMINAIRE POLE LOCATIONS WILL BE STAKED BY THE CONTRACTOR AND APPROVED BY THE ENGINEER.
- 5.) IT IS THE CONTRACTORS RESPONSIBILITY TO FIELD LOCATE ALL EXISTING UTILITIES.
- 6.) LUMINAIRES WILL BE PLACED PERPENDICULAR TO THE ROADWAY AS PER DEPARTMENT REQUIREMENTS.

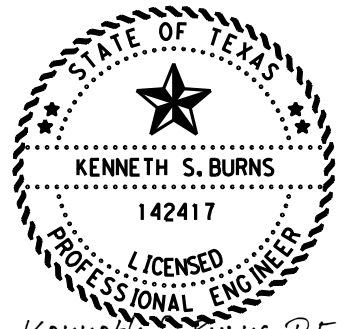

Kenneth S. Burns, P.E.

1/30/2024

**PROPOSED
ILLUMINATION
LAYOUT
US 271 AT FM 726**

© 2024 Texas Department of Transportation

SHEET 3 OF 3

FHWA TEXAS DIVISION		CONSTRUCTION PROJECT NO.		SHEET NO.	
				47	
STATE	DISTRICT	COUNTY			
TEXAS	ATL	MORRIS			
CONTROL	SECTION	JOB	HIGHWAY NO.		
0010	08	060	US 67		

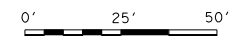

FILE: T:\engdata\Traffic\NGN\192515_Jamie\JOBS\LIGHTING PROJECTS\Lighting Project May 2024\Intersections\US 271 at FM 726.dgn
 DATE: 1/25/2024 9:07:10 AM

LEGEND

- EXISTING SIGN TO BE REMOVED
- PROPOSED SIGN
- PREFAB PAV MRK TY C (W) (24") (SLD)
- PREFAB PAV MRK TY C (W) (ARROW)
- PREFAB PAV MRK TY C (W) (WORD)
- PREFAB PAV MRK TY C (W) (36") (YLD TRI)
- PREFORMED IN-LANE (TRANS) RUMBLE STRIP

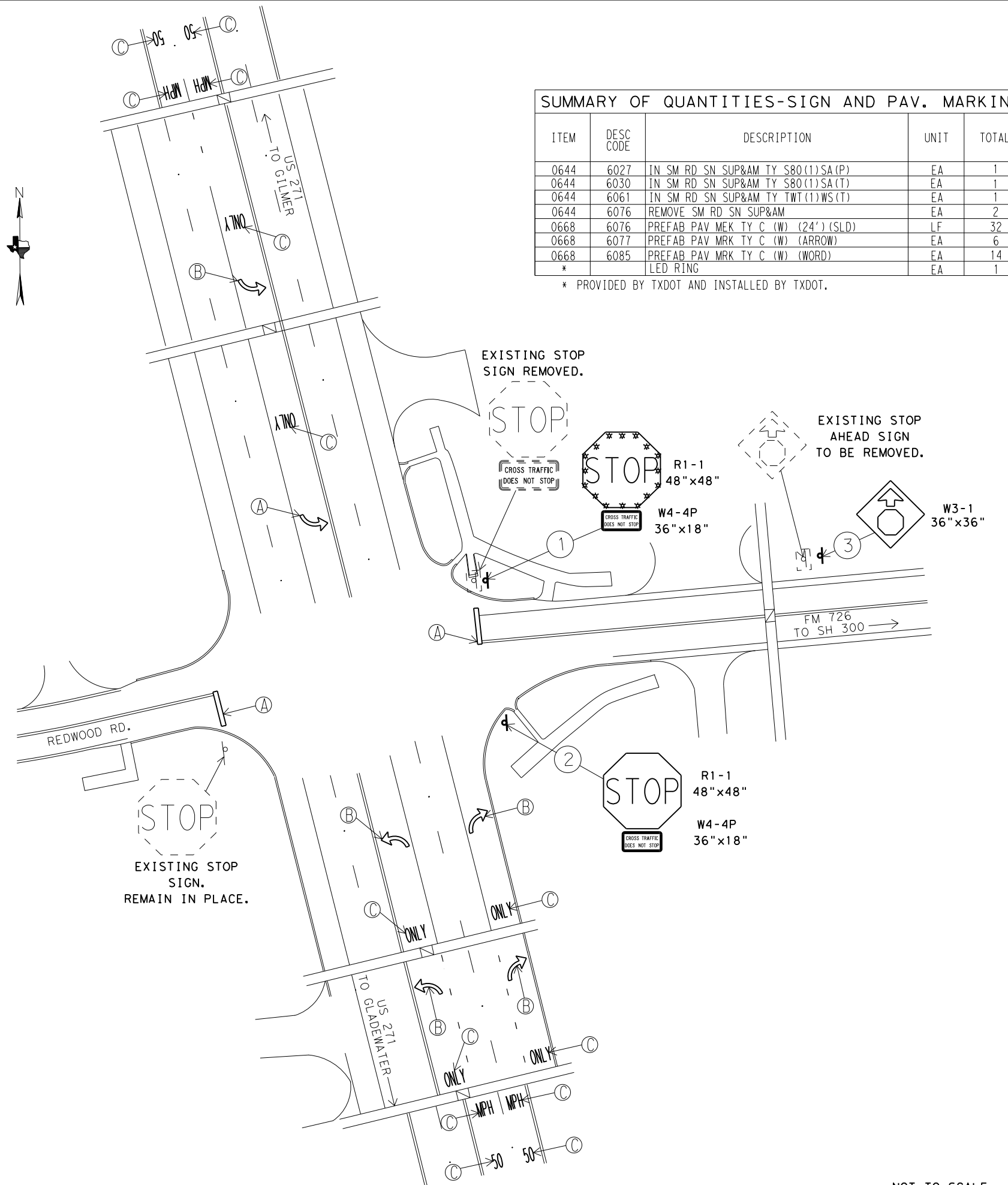

SUMMARY OF QUANTITIES-SIGN AND PAV. MARKING

ITEM	DESC CODE	DESCRIPTION	UNIT	TOTAL
0644	6027	IN SM RD SN SUP&AM TY S80(1)SA(P)	EA	1
0644	6030	IN SM RD SN SUP&AM TY S80(1)SA(T)	EA	1
0644	6061	IN SM RD SN SUP&AM TY TWT(1)WS(T)	EA	1
0644	6076	REMOVE SM RD SN SUP&AM	EA	2
0668	6076	PREFAB PAV MEK TY C (W) (24") (SLD)	LF	32
0668	6077	PREFAB PAV MRK TY C (W) (ARROW)	EA	6
0668	6085	PREFAB PAV MRK TY C (W) (WORD)	EA	14
*		LED RING	EA	1

* PROVIDED BY TXDOT AND INSTALLED BY TXDOT.

NOTE:

- 1.) REMOVE EXISTING STOP SIGN ON FM 726. INSTALL PROPOSED STOP SIGN WITH CROSS TRAFFIC DOES NOT STOP PLAQUE AS SHOWN ON FM 726. STOP SIGN ON REDWOOD RD. TO REMAIN IN PLACE. THE STOP SIGN SHOWN WITH THE LED RING WILL NEED TO HAVE THE POST 12" TALLER THAN THE TOP OF THE SIGN FOR BEACON INSTALLATION. STATE FORCES WILL COME IN AND INSTALL THE RING ASSEMBLY FOR THIS AFTER THE CONTRACTOR HAS MOUNTED THE SIGN.
- 2.) ENSURE 7' MIN CLEARANCE AND 7.5' MAX VERTICAL CLEARANCE TO BOTTOM OF SUPPLEMENTAL PLAQUE (CROSS TRAFFIC DOES NOT STOP). REFER TO SIGN STANDARD SMD (GEN)-08 FOR SIGN PLACEMENT DETAILS.
- 3.) REMOVE EXISTING STOP AHEAD SIGN AND POST ON THE APPROACH AS SHOWN. INSTALL STOP AHEAD SIGN IN A RANGE OF A MINIMUM DISTANCE OF 975'. MAINTAIN A MINIMUM 325' SPACING BETWEEN EXISTING SIGNS.
- 4.) INSTALLED SIGN ASSEMBLIES WILL REQUIRE OMNI-DIRECTIONAL POST WRAP. THIS WRAP WILL BE SUBSIDIARY TO ITEM 644. REFERENCE ITEM 644 SMALL ROADSIDE SIGN ASSEMBLIES IN THE GENERAL NOTES FOR MORE INFORMATION.
- 5.) RESTRIPE EXISTING STOP BARS, ARROWS, AND WORDS IN PLACE.

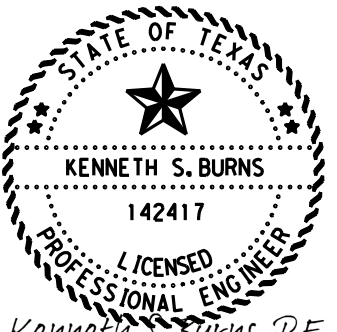

Kenneth S. Burns, P.E.
 1/30/2024

**PROPOSED
 SIGN AND
 PAVEMENT MARKING
 LAYOUT
 US 271 AT FM 726**



FHWA TEXAS DIVISION		CONSTRUCTION PROJECT NO.		SHEET NO.	
				48	
STATE	DISTRICT	COUNTY			
TEXAS	ATL	MORRIS			
CONTROL	SECTION	JOB	HIGHWAY NO.		
0010	08	060	US 67		

NOT TO SCALE

FILE: T:\engdata\Traffic\DN\192515 Jamie\JOBS\LIGHTING PROJECTS\Lighting Project May 2024\Intersections\US 259 at FM 144\US 259 at FM 144.dgn
 DATE: 1/25/2024 9:07:55 AM

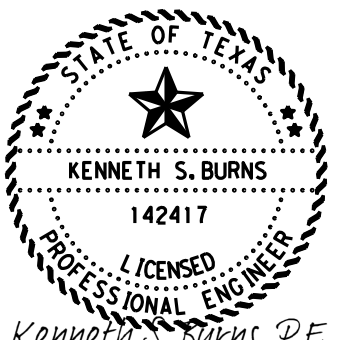
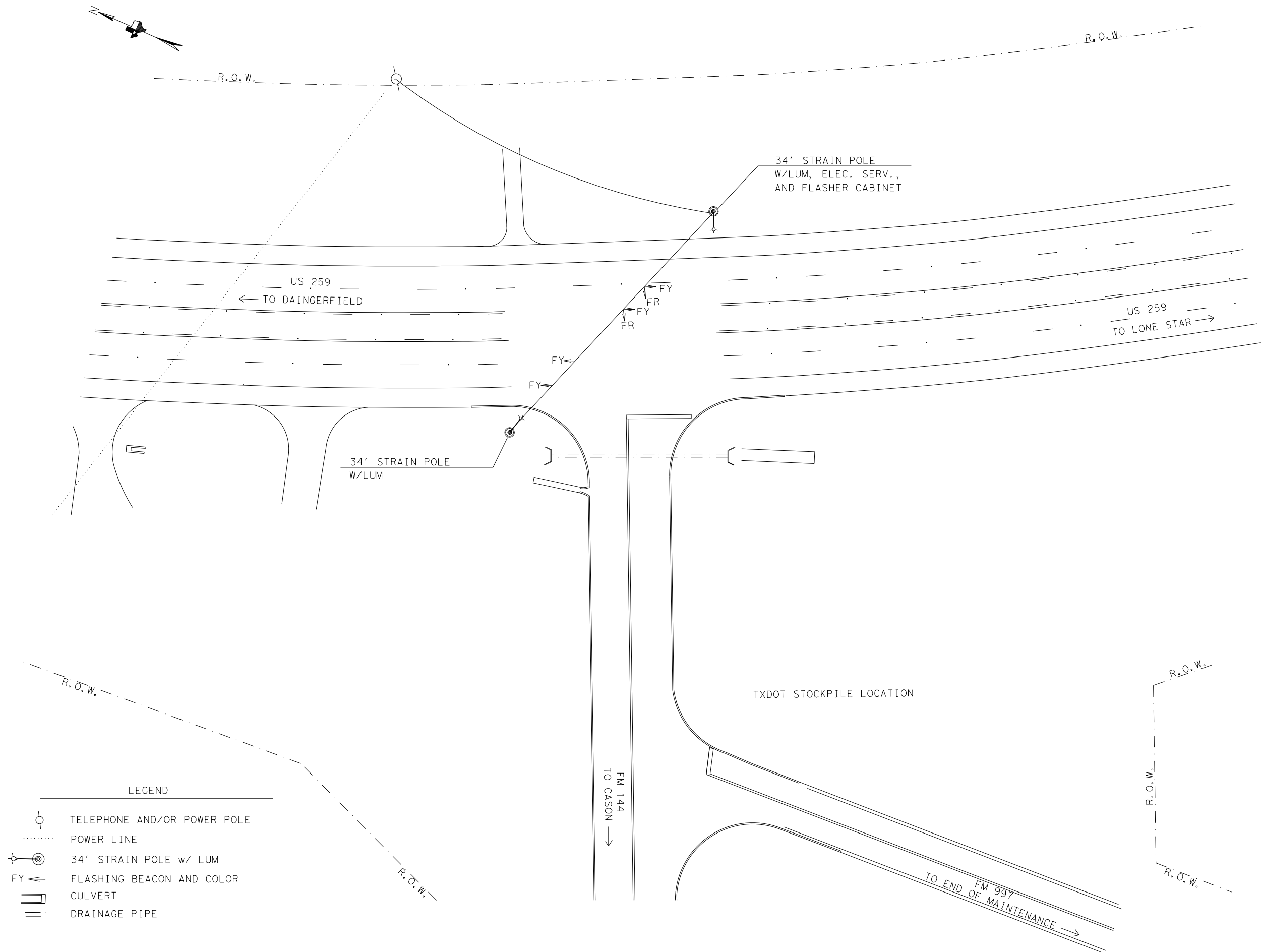

Kenneth S. Burns, P.E.
 1/30/2024

EXISTING CONDITION LAYOUT
US 259 AT FM 144



FHWA TEXAS DIVISION		CONSTRUCTION PROJECT NO.		SHEET NO.
				49
STATE	DISTRICT	COUNTY		
TEXAS	ATL	MORRIS		
CONTROL	SECTION	JOB	HIGHWAY NO.	
0010	08	060	US 67	

FILE: T:\engdata\Traffic\DN\d192515 Jamie\JOBS\LIGHTING PROJECTS\Lighting Project May 2024\Intersections\US 259 at FM 144\US 259 at FM 144.dgn
 DATE: 1/25/2024 9:08:48 AM

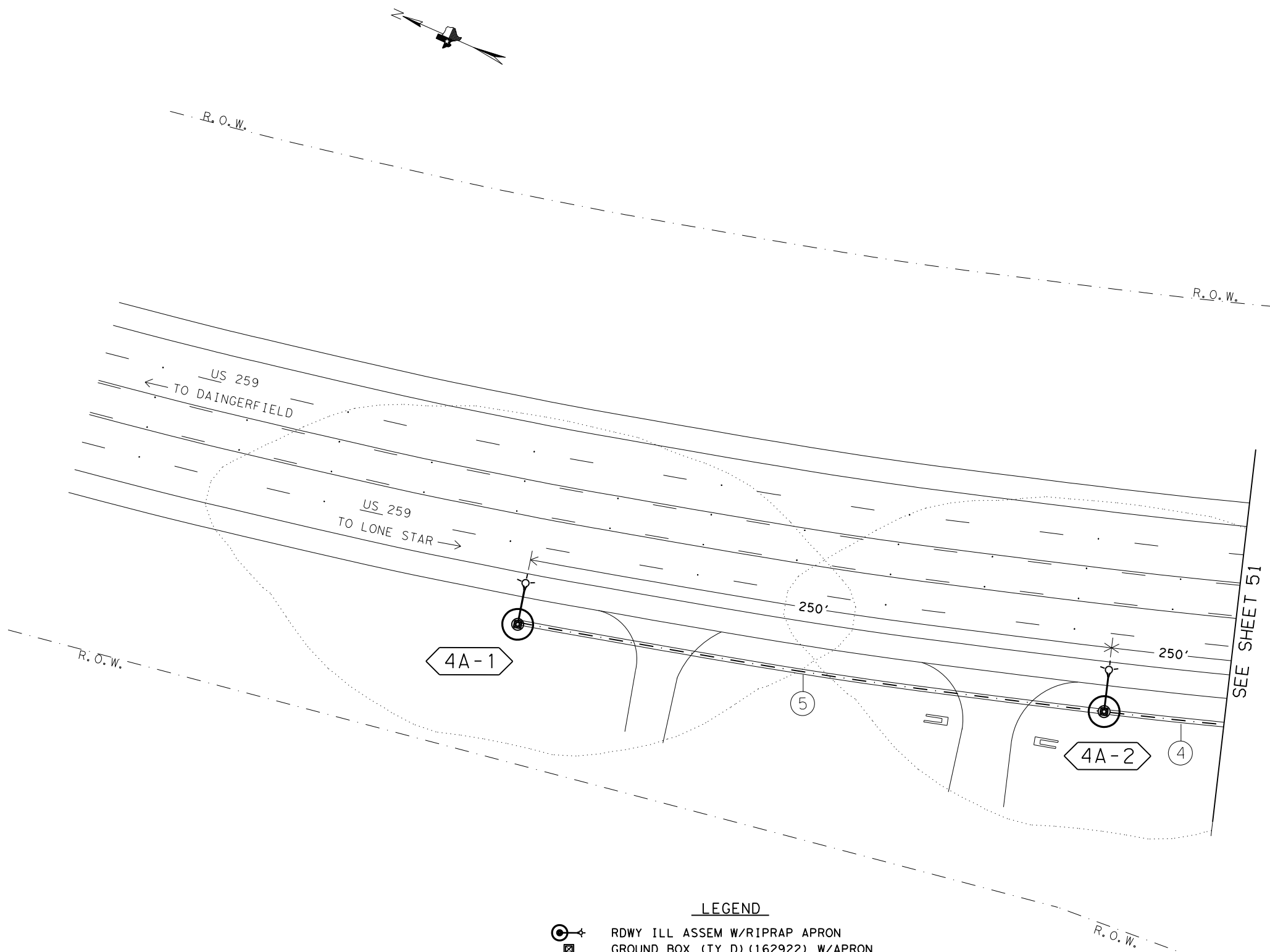

- NOTE:
- 1.) INSTALL PROPOSED ROADWAY ILLUMINATION ASSEMBLIES. REMOVE EXISTING STRAIN POLES AND SPAN WIRE. REMOVE FOUNDATIONS FOR STRAIN POLES 2' BELOW GRADE IN ACCORDANCE WITH ITEM 680 6004 REMOVING TRAFFIC SIGNALS. ALL REMOVAL ITEMS WILL BECOME THE PROPERTY OF THE CONTRACTOR UPON REMOVAL.
 - 2.) OVERHEAD FLASHING BEACONS ARE NOT TO BE REMOVED UNTIL THE PROPOSED ROADWAY ILLUMINATION ASSEMBLIES ARE FUNCTIONING AND PROPOSED STOP SIGNS INSTALLED.
 - 3.) LUMINAIRES WILL BE INSTALLED MIN. 15' OFF OF TRAVEL LANE LINE UNLESS OTHERWISE NOTED.
 - 4.) LUMINAIRE POLE LOCATIONS WILL BE STAKED BY THE CONTRACTOR AND APPROVED BY THE ENGINEER.
 - 5.) IT IS THE CONTRACTORS RESPONSIBILITY TO FIELD LOCATE ALL EXISTING UTILITIES.
 - 6.) LUMINAIRES WILL BE PLACED PERPENDICULAR TO THE ROADWAY AS PER DEPARTMENT REQUIREMENTS.

LEGEND

	RDWY ILL ASSEM W/RIPRAP APRON
	GROUND BOX (TY D) (162922) W/APRON
	GROUND BOX (TY A) (122311) W/APRON
	GROUND BOX (TY A) (122311)
	TRENCHED CONDUIT
	BORED CONDUIT
	OVERHEAD POWER LINE
	WIRE RUN NUMBER
	LUMINAIRE CIRCUIT & POLE NUMBER
	ELECTRICAL SERVICE
	TELEPHONE AND/OR POWER POLE
	CULVERT
	DRAINAGE PIPE

 Kenneth S. Burns, P.E.
 1/30/2024

**PROPOSED
 ILLUMINATION
 LAYOUT
 US 259 AT FM 144**

© 2024 Texas Department of Transportation
 SHEET 1 OF 4

FHWA TEXAS DIVISION		CONSTRUCTION PROJECT NO.		SHEET NO.
				50
STATE	DISTRICT	COUNTY		
TEXAS	ATL	MORRIS		
CONTROL	SECTION	JOB	HIGHWAY NO.	
0010	08	060	US 67	

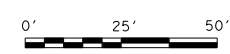

FILE: T:\engdata\Traffic\DN\192515 Jamie\JOBS\LIGHTING PROJECTS\Lighting Project May 2024\Intersections\US 259 at FM 144\US 259 at FM 144.dgn
 DATE: 1/25/2024 9:10:05 AM

NOTE:

- 1.) INSTALL PROPOSED ROADWAY ILLUMINATION ASSEMBLIES. REMOVE EXISTING STRAIN POLES AND SPAN WIRE. REMOVE FOUNDATIONS FOR STRAIN POLES 2' BELOW GRADE IN ACCORDANCE WITH ITEM 680 6004 REMOVING TRAFFIC SIGNALS. ALL REMOVAL ITEMS WILL BECOME THE PROPERTY OF THE CONTRACTOR UPON REMOVAL.
- 2.) OVERHEAD FLASHING BEACONS ARE NOT TO BE REMOVED UNTIL THE PROPOSED ROADWAY ILLUMINATION ASSEMBLIES ARE FUNCTIONING AND PROPOSED STOP SIGNS INSTALLED.
- 3.) LUMINAIRES WILL BE INSTALLED MIN. 15' OFF OF TRAVEL LANE LINE UNLESS OTHERWISE NOTED.
- 4.) LUMINAIRE POLE LOCATIONS WILL BE STAKED BY THE CONTRACTOR AND APPROVED BY THE ENGINEER.
- 5.) IT IS THE CONTRACTORS RESPONSIBILITY TO FIELD LOCATE ALL EXISTING UTILITIES.
- 6.) LUMINAIRES WILL BE PLACED PERPENDICULAR TO THE ROADWAY AS PER DEPARTMENT REQUIREMENTS.

LEGEND

- RDWY ILL ASSEM W/RIPRAP APRON
- GROUND BOX (TY D) (162922) W/APRON
- GROUND BOX (TY A) (122311) W/APRON
- GROUND BOX (TY A) (122311)
- TRENCHED CONDUIT
- BORED CONDUIT
- OVERHEAD POWER LINE
- WIRE RUN NUMBER
- LUMINAIRE CIRCUIT & POLE NUMBER
- ELECTRICAL SERVICE
- TELEPHONE AND/OR POWER POLE
- CULVERT
- DRAINAGE PIPE

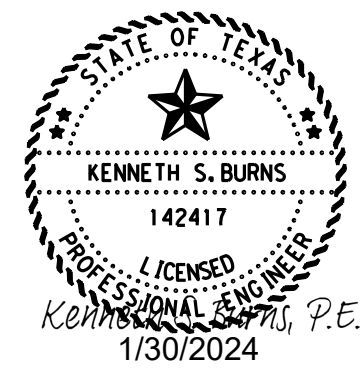
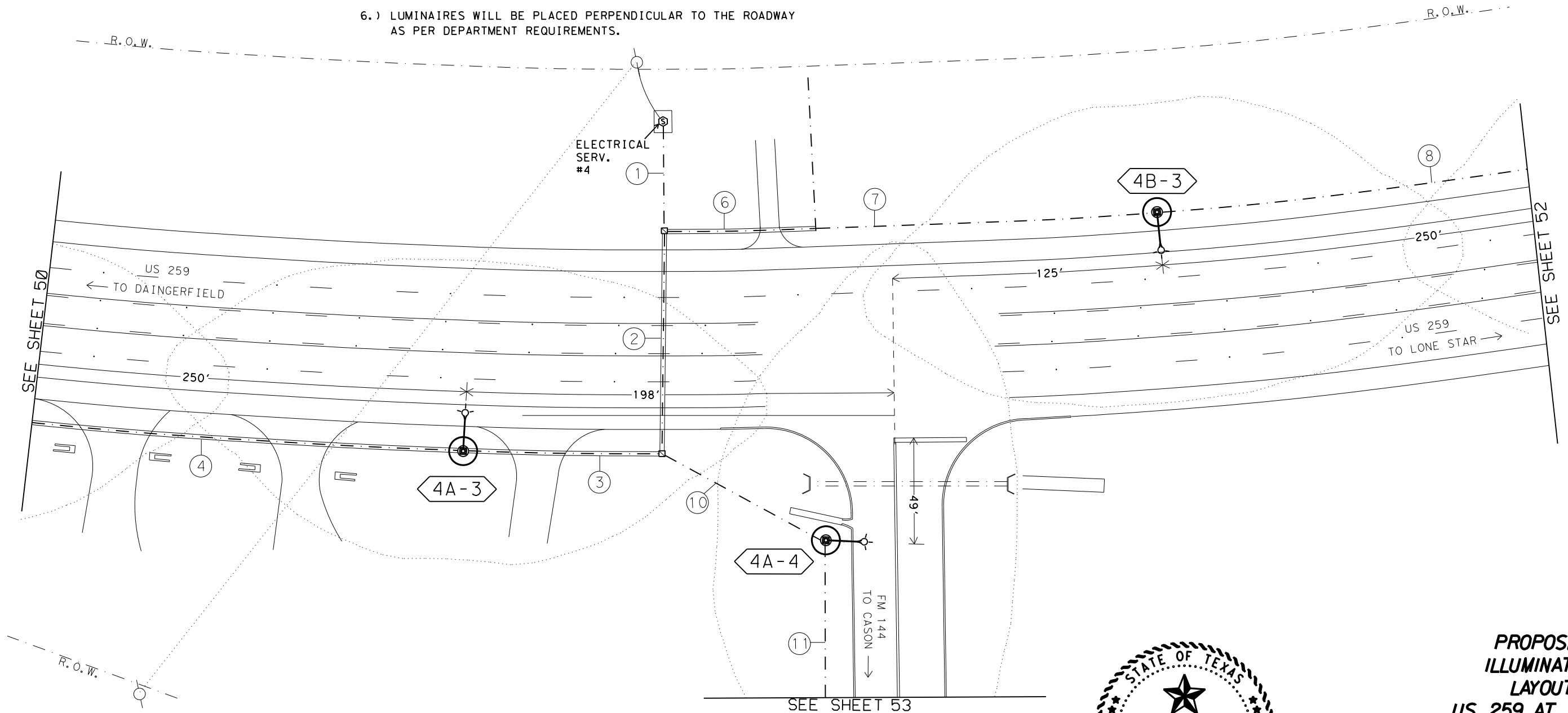

PROPOSED ILLUMINATION LAYOUT
US 259 AT FM 144

© 2024 Texas Department of Transportation
 SHEET 2 OF 4

FHWA TEXAS DIVISION		CONSTRUCTION PROJECT NO.		SHEET NO.
				51
STATE	DISTRICT	COUNTY		
TEXAS	ATL	MORRIS		
CONTROL	SECTION	JOB	HIGHWAY NO.	
0010	08	060	US 67	

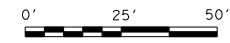

FILE: T:\engdata\Traffic\DN\192515 Jamie\JOBS\LIGHTING PROJECTS\LIGHTING Project May 2024\Intersections\US 259 at FM 144\US 259 at FM 144.dgn
 DATE: 1/25/2024 9:11:02 AM

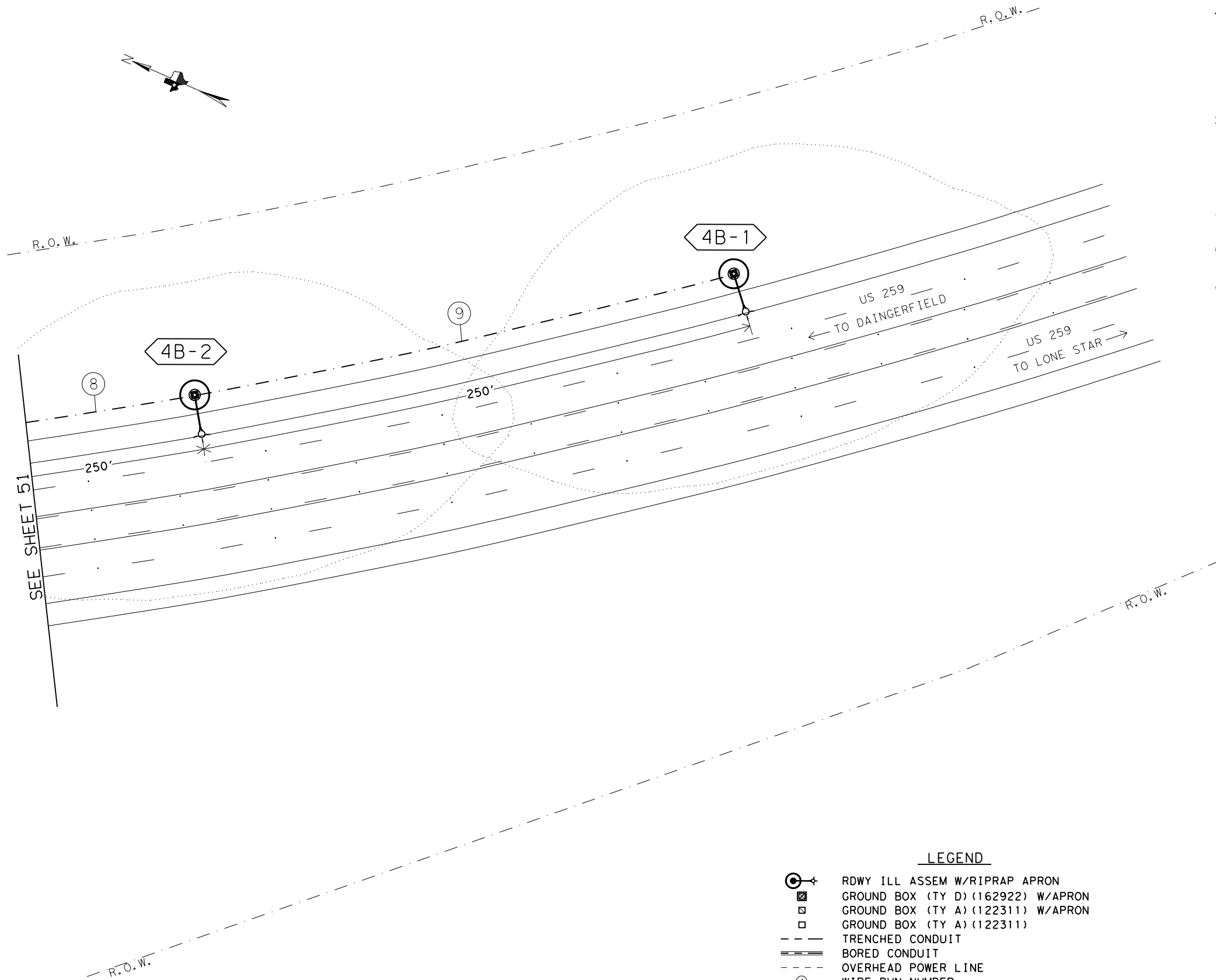

NOTE:

- 1.) INSTALL PROPOSED ROADWAY ILLUMINATION ASSEMBLIES. REMOVE EXISTING STRAIN POLES AND SPAN WIRE. REMOVE FOUNDATIONS FOR STRAIN POLES 2' BELOW GRADE IN ACCORDANCE WITH ITEM 680 6004 REMOVING TRAFFIC SIGNALS. ALL REMOVAL ITEMS WILL BECOME THE PROPERTY OF THE CONTRACTOR UPON REMOVAL.
- 2.) OVERHEAD FLASHING BEACONS ARE NOT TO BE REMOVED UNTIL THE PROPOSED ROADWAY ILLUMINATION ASSEMBLIES ARE FUNCTIONING AND PROPOSED STOP SIGNS INSTALLED.
- 3.) LUMINAIRES WILL BE INSTALLED MIN. 15' OFF OF TRAVEL LANE LINE UNLESS OTHERWISE NOTED.
- 4.) LUMINAIRE POLE LOCATIONS WILL BE STAKED BY THE CONTRACTOR AND APPROVED BY THE ENGINEER.
- 5.) IT IS THE CONTRACTORS RESPONSIBILITY TO FIELD LOCATE ALL EXISTING UTILITIES.
- 6.) LUMINAIRES WILL BE PLACED PERPENDICULAR TO THE ROADWAY AS PER DEPARTMENT REQUIREMENTS.

LEGEND

- RDWY ILL ASSEM W/RIPRAP APRON
- GROUND BOX (TY D) (162922) W/APRON
- GROUND BOX (TY A) (122311) W/APRON
- GROUND BOX (TY A) (122311)
- TRENCHED CONDUIT
- BORED CONDUIT
- OVERHEAD POWER LINE
- WIRE RUN NUMBER
- LUMINAIRE CIRCUIT & POLE NUMBER
- ELECTRICAL SERVICE
- TELEPHONE AND/OR POWER POLE
- CULVERT
- DRAINAGE PIPE

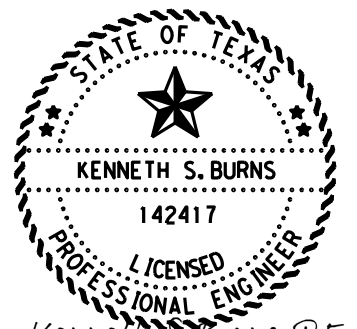

Kenneth S. Burns, P.E.

1/30/2024

**PROPOSED
ILLUMINATION
LAYOUT
US 259 AT FM 144**

© 2024 Texas Department of Transportation
SHEET 3 OF 4

FHWA TEXAS DIVISION		CONSTRUCTION PROJECT NO.		SHEET NO.
				52
STATE	DISTRICT	COUNTY		
TEXAS	ATL	MORRIS		
CONTROL	SECTION	JOB	HIGHWAY NO.	
0010	08	060	US 67	

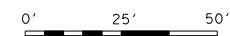

FILE: T:\engdata\Traffic\DN\192515 Jamie\JOBS\LIGHTING PROJECTS\Lighting Project May 2024\Intersections\US 259 at FM 144\US 259 at FM 144.dgn
 DATE: 1/25/2024 9:11:40 AM

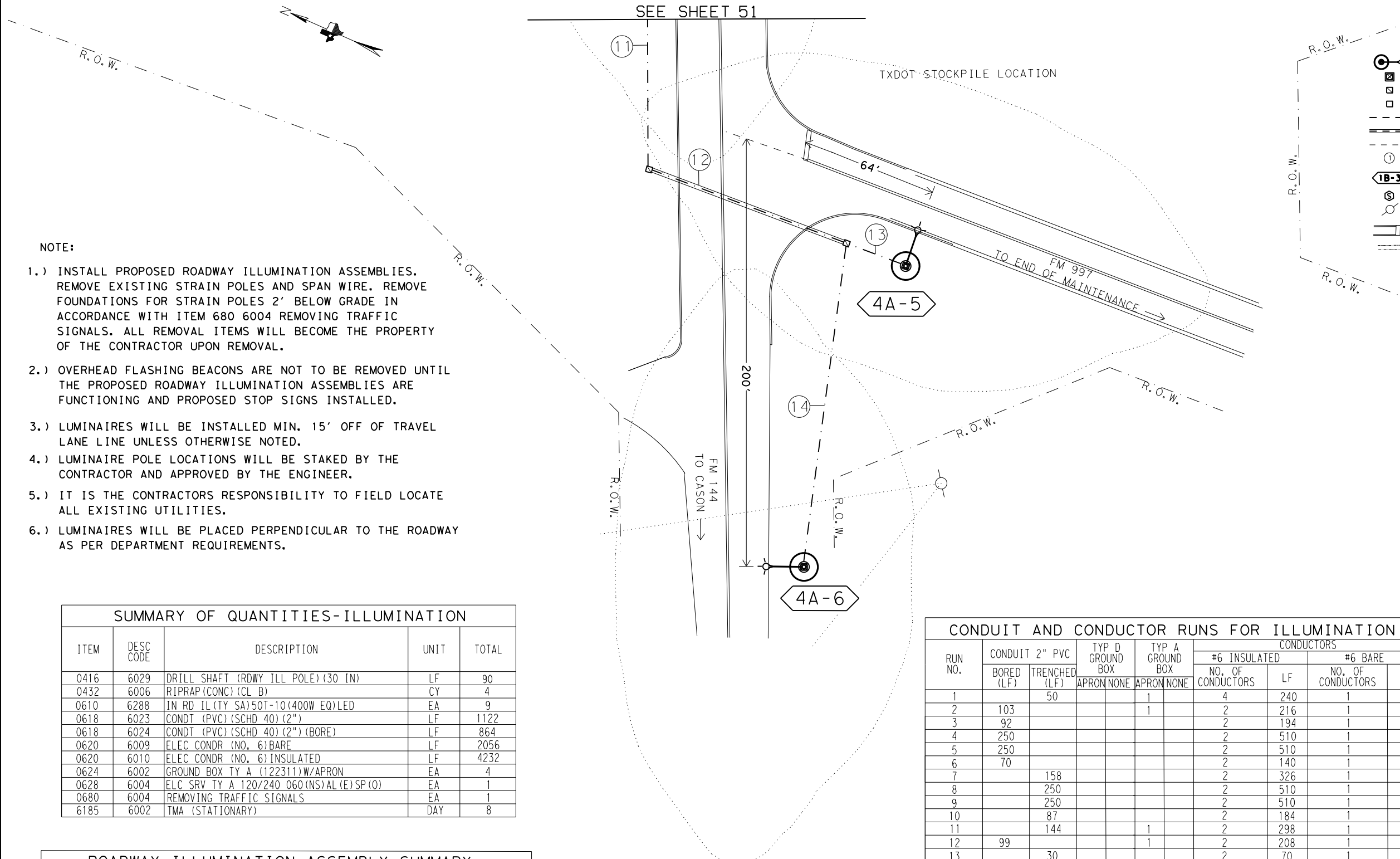

NOTE:

- 1.) INSTALL PROPOSED ROADWAY ILLUMINATION ASSEMBLIES. REMOVE EXISTING STRAIN POLES AND SPAN WIRE. REMOVE FOUNDATIONS FOR STRAIN POLES 2' BELOW GRADE IN ACCORDANCE WITH ITEM 680 6004 REMOVING TRAFFIC SIGNALS. ALL REMOVAL ITEMS WILL BECOME THE PROPERTY OF THE CONTRACTOR UPON REMOVAL.
- 2.) OVERHEAD FLASHING BEACONS ARE NOT TO BE REMOVED UNTIL THE PROPOSED ROADWAY ILLUMINATION ASSEMBLIES ARE FUNCTIONING AND PROPOSED STOP SIGNS INSTALLED.
- 3.) LUMINAIRES WILL BE INSTALLED MIN. 15' OFF OF TRAVEL LANE LINE UNLESS OTHERWISE NOTED.
- 4.) LUMINAIRE POLE LOCATIONS WILL BE STAKED BY THE CONTRACTOR AND APPROVED BY THE ENGINEER.
- 5.) IT IS THE CONTRACTORS RESPONSIBILITY TO FIELD LOCATE ALL EXISTING UTILITIES.
- 6.) LUMINAIRES WILL BE PLACED PERPENDICULAR TO THE ROADWAY AS PER DEPARTMENT REQUIREMENTS.

LEGEND

- RDWY ILL ASSEM W/RIPRAP APRON
- GROUND BOX (TY D) (162922) W/APRON
- GROUND BOX (TY A) (122311) W/APRON
- TRENCHED CONDUIT
- BORED CONDUIT
- OVERHEAD POWER LINE
- WIRE RUN NUMBER
- LUMINAIRE CIRCUIT & POLE NUMBER
- ELECTRICAL SERVICE
- TELEPHONE AND/OR POWER POLE
- CULVERT
- DRAINAGE PIPE

SUMMARY OF QUANTITIES-ILLUMINATION

ITEM	DESC CODE	DESCRIPTION	UNIT	TOTAL
0416	6029	DRILL SHAFT (RDWY ILL POLE) (30 IN)	LF	90
0432	6006	RIPRAP (CONC) (CL B)	CY	4
0610	6288	IN RD IL (TY SA) 50T-10 (400W EQ) LED	EA	9
0618	6023	COND (PVC) (SCHD 40) (2")	LF	1122
0618	6024	COND (PVC) (SCHD 40) (2") (BORE)	LF	864
0620	6009	ELEC CONDR (NO. 6) BARE	LF	2056
0620	6010	ELEC CONDR (NO. 6) INSULATED	LF	4232
0624	6002	GROUND BOX TY A (122311) W/APRON	EA	4
0628	6004	ELC SRV TY A 120/240 060 (NS) AL (E) SP (O)	EA	1
0680	6004	REMOVING TRAFFIC SIGNALS	EA	1
6185	6002	TMA (STATIONARY)	DAY	8

ROADWAY ILLUMINATION ASSEMBLY SUMMARY

POLE	TYPE	FND. (LF)	REMARKS
4A-1	(TY SA) 50T-10 (400W EQ) LED	10	18' OFF TRAVEL LANE
4A-2	(TY SA) 50T-10 (400W EQ) LED	10	18' OFF TRAVEL LANE
4A-3	(TY SA) 50T-10 (400W EQ) LED	10	18' OFF TRAVEL LANE
4A-4	(TY SA) 50T-10 (400W EQ) LED	10	10' OFF BACK OF CURB
4A-5	(TY SA) 50T-10 (400W EQ) LED	10	10' OFF BACK OF CURB
4A-6	(TY SA) 50T-10 (400W EQ) LED	10	15' OFF TRAVEL LANE
4B-1	(TY SA) 50T-10 (400W EQ) LED	10	17' OFF TRAVEL LANE
4B-2	(TY SA) 50T-10 (400W EQ) LED	10	17' OFF TRAVEL LANE
4B-3	(TY SA) 50T-10 (400W EQ) LED	10	17' OFF TRAVEL LANE

CONDUIT AND CONDUCTOR RUNS FOR ILLUMINATION

RUN NO.	CONDUIT 2" PVC		TYP D GROUND BOX APRON NONE	TYP A GROUND BOX APRON NONE	CONDUCTORS			
	BORED (LF)	TRENCHED (LF)			#6 INSULATED		#6 BARE	
					NO. OF CONDUCTORS	LF	NO. OF CONDUCTORS	LF
1		50		1	4	240	1	60
2	103			1	2	216	1	108
3	92				2	194	1	97
4	250				2	510	1	255
5	250				2	510	1	255
6	70				2	140	1	70
7		158			2	326	1	163
8		250			2	510	1	255
9		250			2	510	1	255
10		87			2	184	1	92
11		144		1	2	298	1	149
12	99			1	2	208	1	104
13		30			2	70	1	35
14		153			2	316	1	158
TOTALS	864	1122		4		4232		2056

* CALCULATIONS FOR WIRE TOTALS:
 -5' OF SLACK FOR GROUND BOXES. (PER CONDUCTOR)
 -5' OF SLACK FOR WIRE IN THE SERVICE. (PER CONDUCTOR)
 -5' OF SLACK FOR WIRE IN THE BASE OF ILLUMINATION POLES. (PER CONDUCTOR)

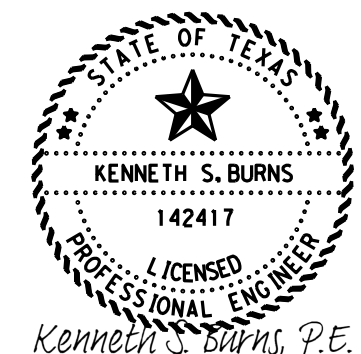

Kenneth S. Burns, P.E.

1/30/2024

PROPOSED ILLUMINATION LAYOUT US 259 AT FM 144

© 2024 Texas Department of Transportation
 SHEET 4 OF 4

FHWA TEXAS DIVISION		CONSTRUCTION PROJECT NO.		SHEET NO.
				53
STATE	DISTRICT	COUNTY		
TEXAS	ATL	MORRIS		
CONTROL	SECTION	JOB	HIGHWAY NO.	
0010	08	060	US 67	



FILE: T:\engdata\Traffic\DN\d192515 Jamie\JOBS\LIGHTING PROJECTS\Lighting Project May 2024\Intersections\US 259 at FM 144\US 259 at FM 144.dgn
 DATE: 1/25/2024 9:13:04 AM

SUMMARY OF QUANTITIES-SIGN AND PAV. MARKING

ITEM	DESC CODE	DESCRIPTION	UNIT	TOTAL
0644	6027	IN SM RD SN SUP&AM TY S80(1)SA(P)	EA	1
0644	6061	IN SM RD SN SUP&AM TY TWT(1)WS(T)	EA	2
0644	6076	REMOVE SM RD SN SUP&AM	EA	2
0668	6076	PREFAB PAV MRK TY C (W) (24') (SLD)	LF	34
*		LED RING	EA	1

* PROVIDED BY TXDOT AND INSTALLED BY TXDOT.

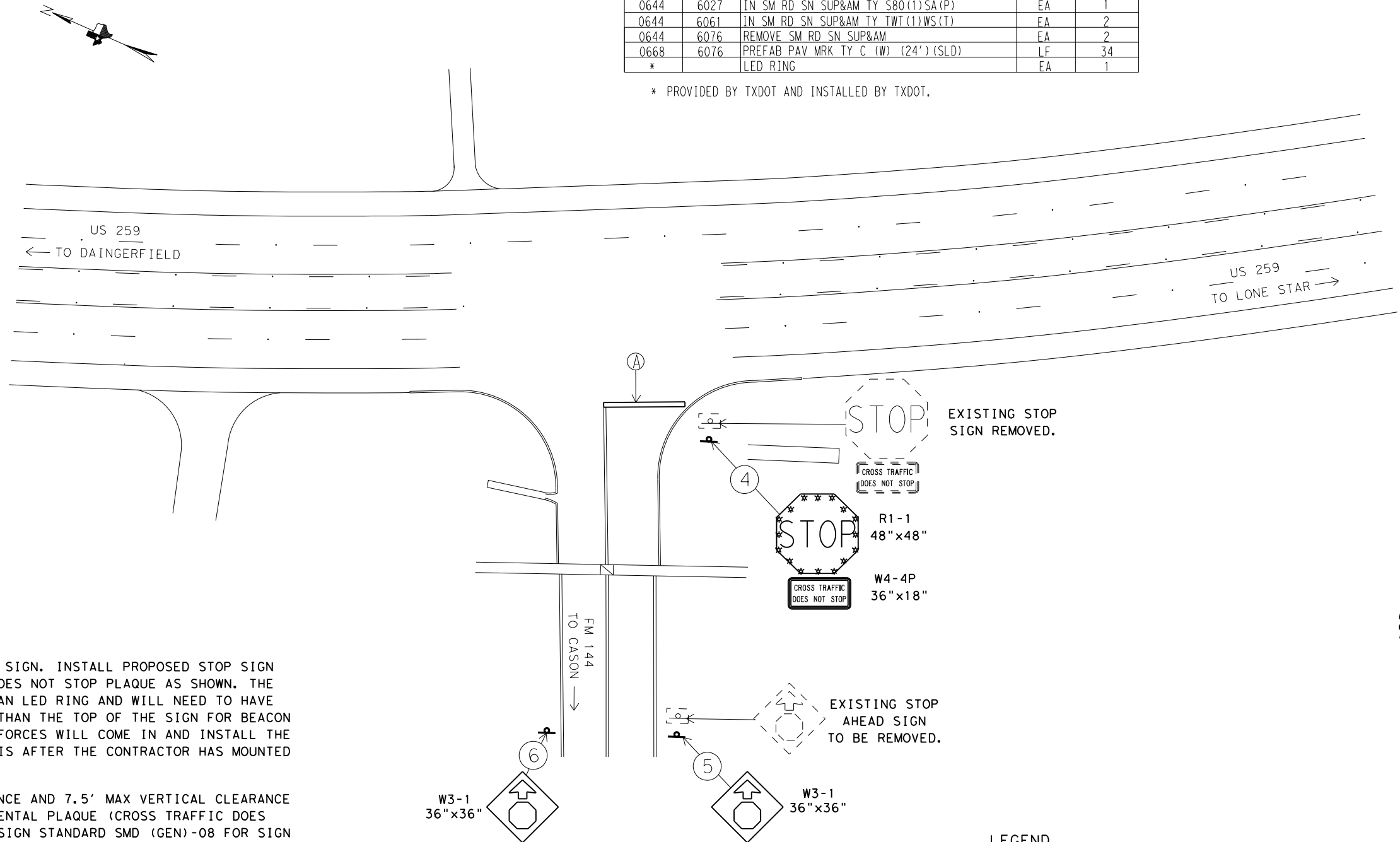

NOTE:

- 1.) REMOVE EXISTING STOP SIGN. INSTALL PROPOSED STOP SIGN WITH CROSS TRAFFIC DOES NOT STOP PLAQUE AS SHOWN. THE STOP SIGN WILL HAVE AN LED RING AND WILL NEED TO HAVE THE POST 12" TALLER THAN THE TOP OF THE SIGN FOR BEACON INSTALLATION. STATE FORCES WILL COME IN AND INSTALL THE RING ASSEMBLY FOR THIS AFTER THE CONTRACTOR HAS MOUNTED THE SIGN.
- 2.) ENSURE 7' MIN CLEARANCE AND 7.5' MAX VERTICAL CLEARANCE TO BOTTOM OF SUPPLEMENTAL PLAQUE (CROSS TRAFFIC DOES NOT STOP). REFER TO SIGN STANDARD SMD (GEN)-08 FOR SIGN PLACEMENT DETAILS.
- 3.) REMOVE EXISTING STOP AHEAD SIGN AND POST ON THE APPROACH AS SHOWN. INSTALL STOP AHEAD SIGNS IN A RANGE OF A MINIMUM DISTANCE OF 975' TO 1150'. MAINTAIN A MINIMUM 325' SPACING BETWEEN EXISTING SIGNS.
- 4.) INSTALLED SIGN ASSEMBLIES WILL REQUIRE OMNI-DIRECTIONAL POST WRAP. THIS WRAP WILL BE SUBSIDIARY TO ITEM 644. REFERENCE ITEM 644 SMALL ROADSIDE SIGN ASSEMBLIES IN THE GENERAL NOTES FOR MORE INFORMATION.
- 5.) RESTRIPE EXISTING STOP BAR IN PLACE.

LEGEND

- EXISTING SIGN TO BE REMOVED
- PROPOSED SIGN
- PREFAB PAV MRK TY C (W) (24") (SLD)
- PREFAB PAV MRK TY C (W) (ARROW)
- PREFAB PAV MRK TY C (W) (WORD)
- PREFAB PAV MRK TY C (W) (36") (YLD TRI)
- PREFORMED IN-LANE (TRANS) RUMBLE STRIP

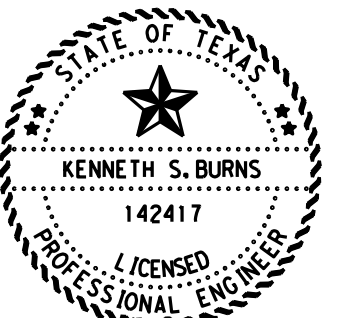

Kenneth S. Burns, P.E.

1/30/2024

**PROPOSED
SIGN AND
PAVEMENT MARKING
LAYOUT
US 259 AT FM 144**









FHWA TEXAS DIVISION		CONSTRUCTION PROJECT NO.		SHEET NO.
				54
STATE	DISTRICT	COUNTY		
TEXAS	ATL	MORRIS		
CONTROL	SECTION	JOB	HIGHWAY NO.	
0010	08	060	US 67	

NOT TO SCALE

FILE: T:\engdata\Traffic\DN\192515 Jamie\JOBS\LIGHTING PROJECTS\Lighting Project May 2024\Intersections\US 259 at FM 3421\US 259 at FM 3421.dgn
 DATE: 1/25/2024 9:14:26 AM

LEGEND

-  TELEPHONE AND/OR POWER POLE
-  POWER LINE
-  34' STRAIN POLE w/ LUM
-  FLASHING BEACON AND COLOR
-  CULVERT
-  DRAINAGE PIPE

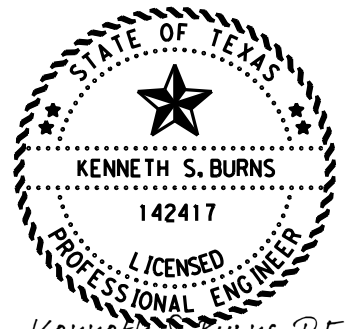
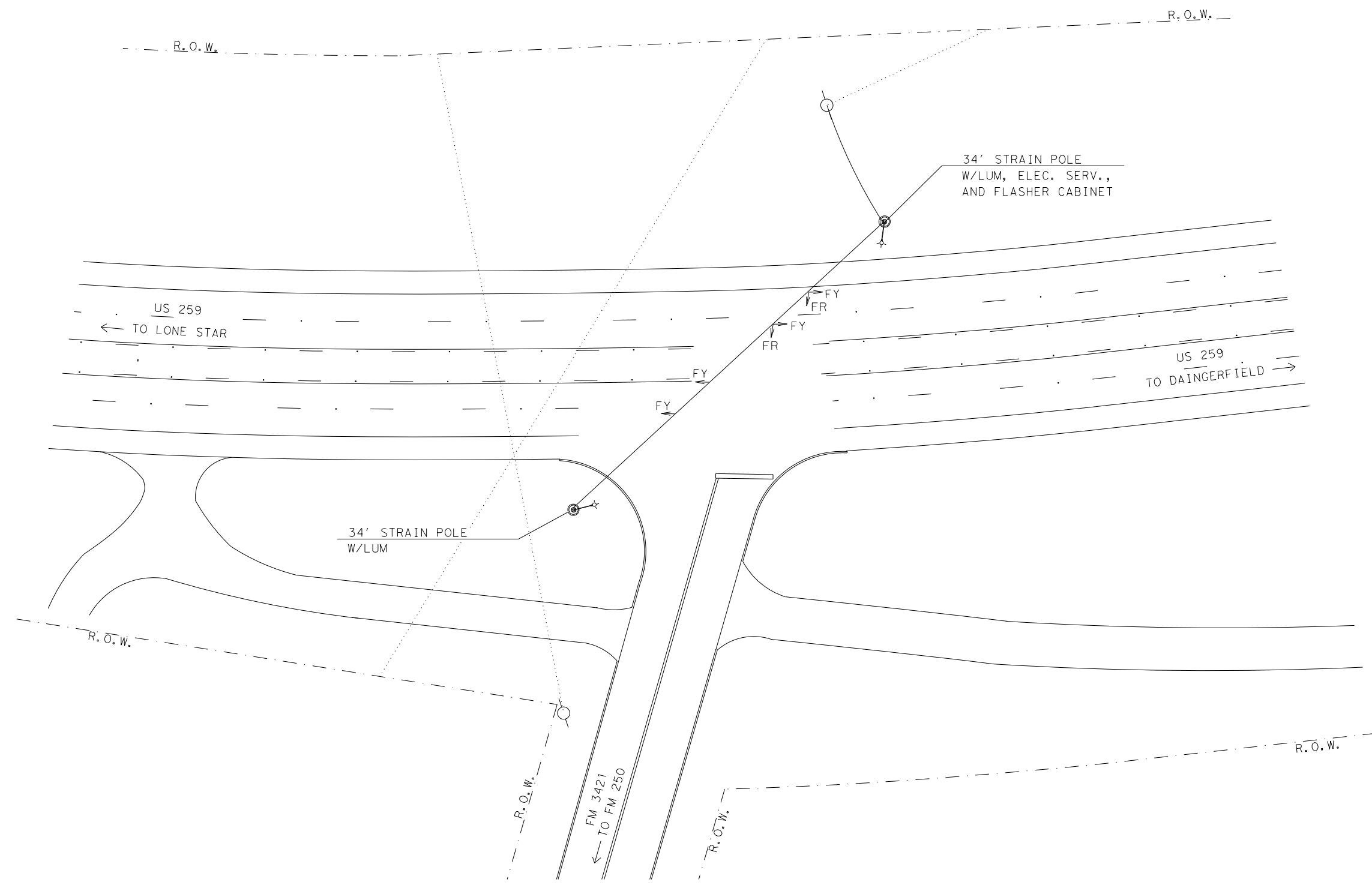

Kenneth S. Burns, P.E.

1/30/2024

**EXISTING CONDITION
 LAYOUT
 US 259 AT FM 3421**

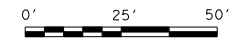

FHWA TEXAS DIVISION		CONSTRUCTION PROJECT NO.		SHEET NO.
				55
STATE	DISTRICT	COUNTY		
TEXAS	ATL	MORRIS		
CONTROL	SECTION	JOB	HIGHWAY NO.	
0010	08	060	US 67	

40' POLES WITH (250W EQ) LED HEADS ALL APPROACHES.

RUN NO.	CONDUIT 2" PVC		TYP D GROUND BOX APRON NONE	TYP A GROUND BOX APRON NONE	CONDUCTORS			
	BORED (LF)	TRENCHED (LF)			#6 INSULATED		#6 BARE	
					NO. OF CONDUCTORS	LF	NO. OF CONDUCTORS	LF
1		19		1	4	116	1	29
2	102			1	2	214	1	107
3		70			2	150	1	75
4	156			1	2	322	1	161
5		55			2	120	1	60
6		86			2	172	1	86
7	55				2	110	1	55
8		59			2	128	1	64
9		105			2	210	1	105
10	67				2	134	1	67
11	28				2	66	1	33
12		53			2	116	1	58
13		200			2	410	1	205
14		200			2	410	1	205
TOTALS	408	847		3		2678		1310

* CALCULATIONS FOR WIRE TOTALS:
 -5' OF SLACK FOR GROUND BOXES. (PER CONDUCTOR)
 -5' OF SLACK FOR WIRE IN THE SERVICE. (PER CONDUCTOR)
 -5' OF SLACK FOR WIRE IN THE BASE OF ILLUMINATION POLES. (PER CONDUCTOR)

POLE	TYPE	FND. (LF)	REMARKS
5A-1	(TY SA)40T-10(250W EQ)LED	10	18' OFF TRAVEL LANE
5A-2	(TY SA)40T-10(250W EQ)LED	10	18' OFF TRAVEL LANE
5A-3	(TY SA)40T-10(250W EQ)LED	10	18' OFF TRAVEL LANE
5A-4	(TY SA)40T-10(250W EQ)LED	10	12' OFF BACK OF CURB
5B-2	(TY SA)40T-10(250W EQ)LED	10	18' OFF TRAVEL LANE
5B-3	(TY SA)40T-10(250W EQ)LED	10	18' OFF TRAVEL LANE
5B-4	(TY SA)40T-10(250W EQ)LED	10	18' OFF TRAVEL LANE

ITEM	DESC CODE	DESCRIPTION	UNIT	TOTAL
0416	6029	DRILL SHAFT (RDWY ILL POLE) (30 IN)	LF	70
0432	6006	RIPRAP (CONC) (CL B)	CY	3
0610	6216	IN RD IL (TY AL)40T-10(250W EQ)LED	EA	7
0618	6023	CONDT (PVC) (SCHD 40) (2")	LF	847
0618	6024	CONDT (PVC) (SCHD 40) (2") (BORE)	LF	408
0620	6009	ELEC CONDR (NO. 6) BARE	LF	1310
0620	6010	ELEC CONDR (NO. 6) INSULATED	LF	2678
0624	6002	GROUND BOX TY A (122311) W/APRON	EA	3
0628	6004	ELC SRV TY A 120/240 060(NS)AL(E)SP(O)	EA	1
0680	6004	REMOVING TRAFFIC SIGNALS	EA	1
6185	6002	TMA (STATIONARY)	DAY	8

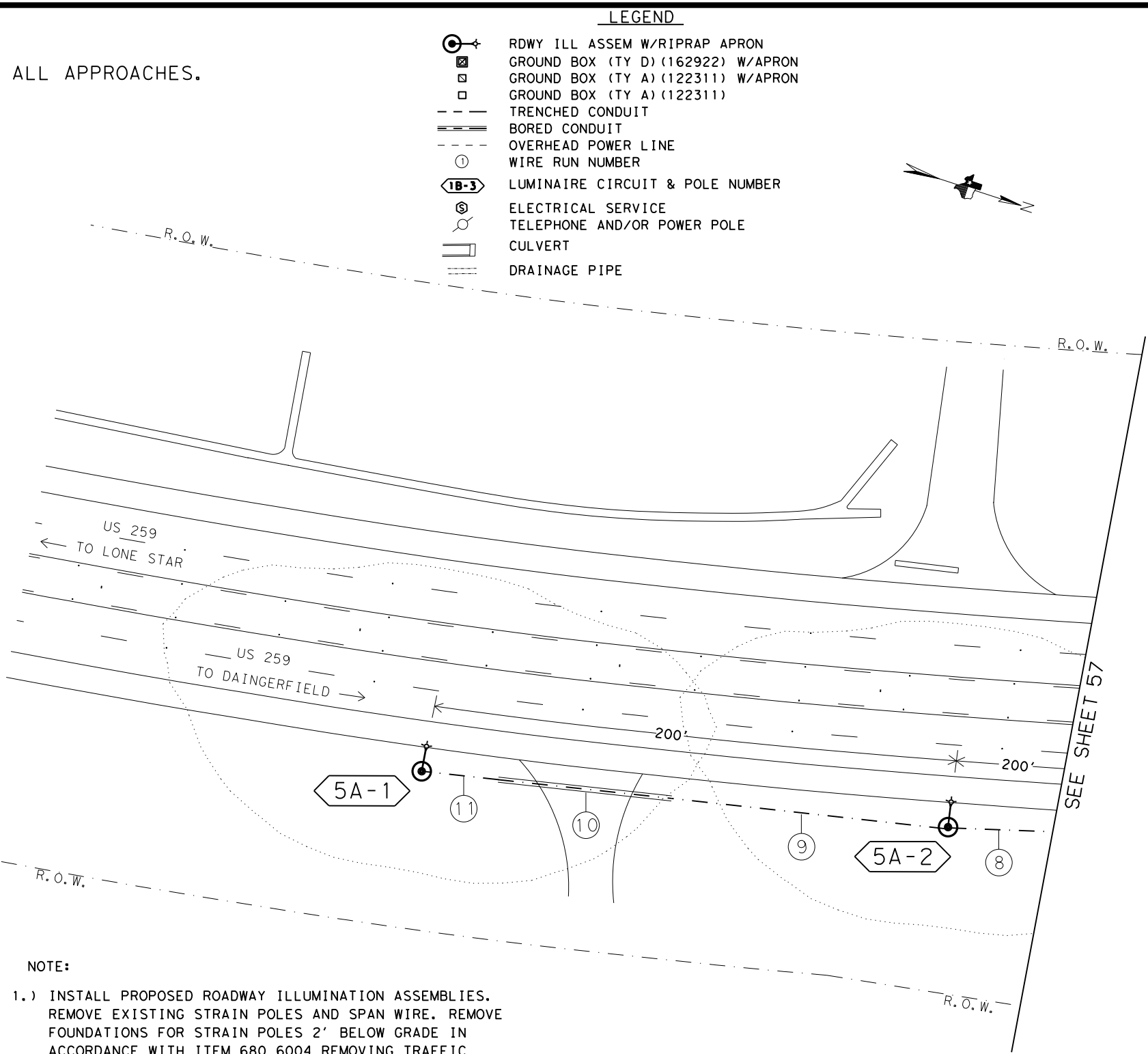

LEGEND

- RDWY ILL ASSEM W/RIPRAP APRON
- GROUND BOX (TY D) (162922) W/APRON
- GROUND BOX (TY A) (122311) W/APRON
- GROUND BOX (TY A) (122311)
- TRENCHED CONDUIT
- BORED CONDUIT
- OVERHEAD POWER LINE
- WIRE RUN NUMBER
- LUMINAIRE CIRCUIT & POLE NUMBER
- ELECTRICAL SERVICE
- TELEPHONE AND/OR POWER POLE
- CULVERT
- DRAINAGE PIPE

NOTE:

- 1.) INSTALL PROPOSED ROADWAY ILLUMINATION ASSEMBLIES. REMOVE EXISTING STRAIN POLES AND SPAN WIRE. REMOVE FOUNDATIONS FOR STRAIN POLES 2' BELOW GRADE IN ACCORDANCE WITH ITEM 680 6004 REMOVING TRAFFIC SIGNALS. ALL REMOVAL ITEMS WILL BECOME THE PROPERTY OF THE CONTRACTOR UPON REMOVAL.
- 2.) OVERHEAD FLASHING BEACONS ARE NOT TO BE REMOVED UNTIL THE PROPOSED ROADWAY ILLUMINATION ASSEMBLIES ARE FUNCTIONING AND PROPOSED STOP SIGNS INSTALLED.
- 3.) LUMINAIRES WILL BE INSTALLED MIN. 15' OFF OF TRAVEL LANE LINE UNLESS OTHERWISE NOTED.
- 4.) LUMINAIRE POLE LOCATIONS WILL BE STAKED BY THE CONTRACTOR AND APPROVED BY THE ENGINEER.
- 5.) IT IS THE CONTRACTORS RESPONSIBILITY TO FIELD LOCATE ALL EXISTING UTILITIES.
- 6.) LUMINAIRES WILL BE PLACED PERPENDICULAR TO THE ROADWAY AS PER DEPARTMENT REQUIREMENTS.

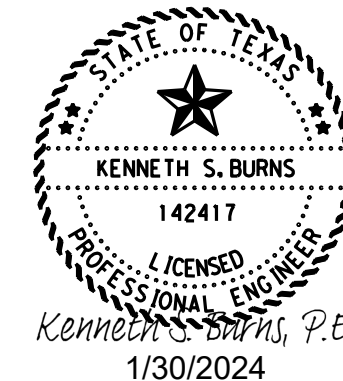

PROPOSED ILLUMINATION LAYOUT
US 259 AT FM 3421

© 2024 Texas Department of Transportation
 SHEET 1 OF 3

STATE	DISTRICT	COUNTY	SHEET NO.
TEXAS	ATL	MORRIS	56
CONTROL	SECTION	JOB	HIGHWAY NO.
0010	08	060	US 67

NOTE:

- 1.) INSTALL PROPOSED ROADWAY ILLUMINATION ASSEMBLIES. REMOVE EXISTING STRAIN POLES AND SPAN WIRE. REMOVE FOUNDATIONS FOR STRAIN POLES 2' BELOW GRADE IN ACCORDANCE WITH ITEM 680 6004 REMOVING TRAFFIC SIGNALS. ALL REMOVAL ITEMS WILL BECOME THE PROPERTY OF THE CONTRACTOR UPON REMOVAL.
- 2.) OVERHEAD FLASHING BEACONS ARE NOT TO BE REMOVED UNTIL THE PROPOSED ROADWAY ILLUMINATION ASSEMBLIES ARE FUNCTIONING AND PROPOSED STOP SIGNS INSTALLED.

NOTE:

- 3.) LUMINAIRES WILL BE INSTALLED MIN. 15' OFF OF TRAVEL LANE LINE UNLESS OTHERWISE NOTED.
- 4.) LUMINAIRE POLE LOCATIONS WILL BE STAKED BY THE CONTRACTOR AND APPROVED BY THE ENGINEER.
- 5.) IT IS THE CONTRACTORS RESPONSIBILITY TO FIELD LOCATE ALL EXISTING UTILITIES.
- 6.) LUMINAIRES WILL BE PLACED PERPENDICULAR TO THE ROADWAY AS PER DEPARTMENT REQUIREMENTS.

LEGEND

- RDWY ILL ASSEM W/RIPRAP APRON
- GROUND BOX (TY D) (162922) W/APRON
- GROUND BOX (TY A) (122311) W/APRON
- TRENCHED CONDUIT
- BORED CONDUIT
- OVERHEAD POWER LINE
- WIRE RUN NUMBER
- LUMINAIRE CIRCUIT & POLE NUMBER
- ELECTRICAL SERVICE
- TELEPHONE AND/OR POWER POLE
- CULVERT
- DRAINAGE PIPE

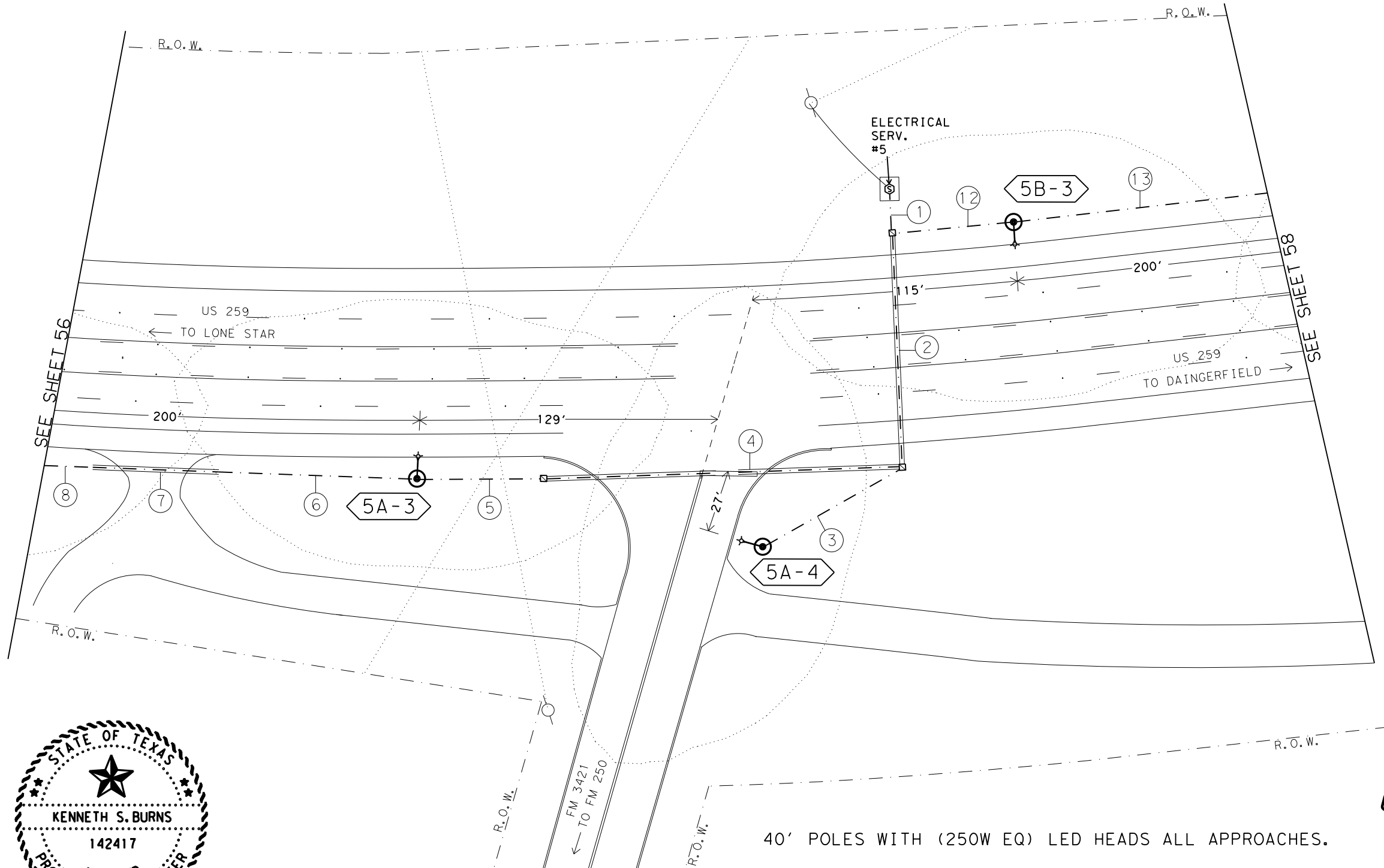

Kenneth S. Burns, P.E.
 1/30/2024

**PROPOSED ILLUMINATION LAYOUT
US 259 AT FM 3421**

40' POLES WITH (250W EQ) LED HEADS ALL APPROACHES.

© 2024 Texas Department of Transportation
 SHEET 2 OF 3

FHWA TEXAS DIVISION		CONSTRUCTION PROJECT NO.		SHEET NO.
				57
STATE	DISTRICT	COUNTY		
TEXAS	ATL	MORRIS		
CONTROL	SECTION	JOB	HIGHWAY NO.	
0010	08	060	US 67	

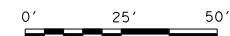

FILE: T:\engdata\Traffic\DN\192515 Jamie\JOBS\LIGHTING PROJECTS\Lighting Project May 2024\Intersections\US 259 at FM 3421\US 259 at FM 3421.dgn
 DATE: 1/25/2024 9:18:50 AM

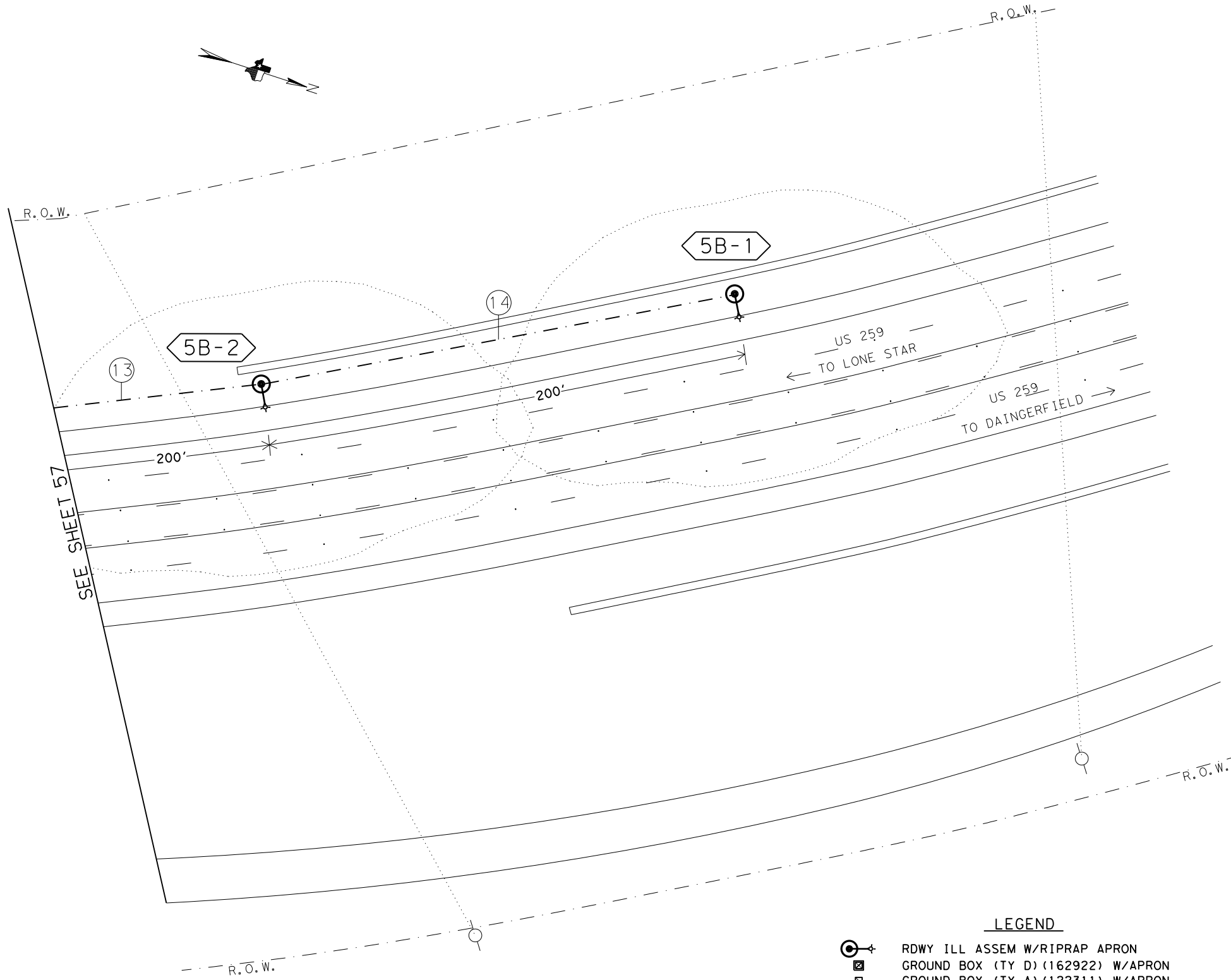

40' POLES WITH (250W EQ) LED HEADS ALL APPROACHES.

LEGEND

- RDWY ILL ASSEM W/RIPRAP APRON
- GROUND BOX (TY D) (162922) W/APRON
- GROUND BOX (TY A) (122311) W/APRON
- GROUND BOX (TY A) (122311)
- TRENCHED CONDUIT
- BORED CONDUIT
- OVERHEAD POWER LINE
- WIRE RUN NUMBER
- LUMINAIRE CIRCUIT & POLE NUMBER
- ELECTRICAL SERVICE
- TELEPHONE AND/OR POWER POLE
- CULVERT
- DRAINAGE PIPE

NOTE:

- 1.) INSTALL PROPOSED ROADWAY ILLUMINATION ASSEMBLIES. REMOVE EXISTING STRAIN POLES AND SPAN WIRE. REMOVE FOUNDATIONS FOR STRAIN POLES 2' BELOW GRADE IN ACCORDANCE WITH ITEM 680 6004 REMOVING TRAFFIC SIGNALS. ALL REMOVAL ITEMS WILL BECOME THE PROPERTY OF THE CONTRACTOR UPON REMOVAL.
- 2.) OVERHEAD FLASHING BEACONS ARE NOT TO BE REMOVED UNTIL THE PROPOSED ROADWAY ILLUMINATION ASSEMBLIES ARE FUNCTIONING AND PROPOSED STOP SIGNS INSTALLED.
- 3.) LUMINAIRES WILL BE INSTALLED MIN. 15' OFF OF TRAVEL LANE LINE UNLESS OTHERWISE NOTED.
- 4.) LUMINAIRE POLE LOCATIONS WILL BE STAKED BY THE CONTRACTOR AND APPROVED BY THE ENGINEER.
- 5.) IT IS THE CONTRACTORS RESPONSIBILITY TO FIELD LOCATE ALL EXISTING UTILITIES.
- 6.) LUMINAIRES WILL BE PLACED PERPENDICULAR TO THE ROADWAY AS PER DEPARTMENT REQUIREMENTS.

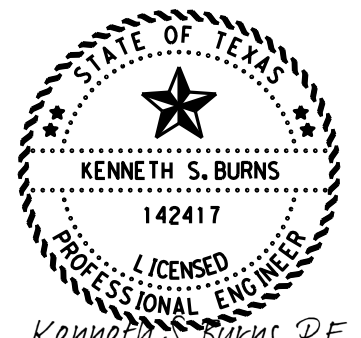

Kenneth S. Burns, P.E.

1/30/2024

**PROPOSED ILLUMINATION LAYOUT
 US 259 AT FM 3421**

© 2024 Texas Department of Transportation
 SHEET 3 OF 3

FHWA TEXAS DIVISION		CONSTRUCTION PROJECT NO.		SHEET NO.
				58
STATE	DISTRICT	COUNTY		
TEXAS	ATL	MORRIS		
CONTROL	SECTION	JOB	HIGHWAY NO.	
0010	08	060	US 67	

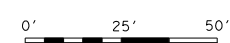

FILE: T:\engdata\Traffic\NGN\192515 Jamie\JOBS\LIGHTING PROJECTS\Lighting Project May 2024\Intersections\US 259 at FM 3421\US 259 at FM 3421.dgn
 DATE: 1/25/2024 9:19:37 AM

SUMMARY OF QUANTITIES-SIGN AND PAV. MARKING				
ITEM	DESC CODE	DESCRIPTION	UNIT	TOTAL
0644	6027	IN SM RD SN SUP&AM TY S80(1)SA(P)	EA	1
0644	6061	IN SM RD SN SUP&AM TY TWT(1)WS(T)	EA	2
0644	6076	REMOVE SM RD SN SUP&AM	EA	2
0668	6076	PREFAB PAV MRK TY C (W) (24') (SLD)	LF	25
*		LED RING	EA	1

* PROVIDED BY TXDOT AND INSTALLED BY TXDOT.

NOTE:

- 1.) REMOVE EXISTING STOP SIGN. INSTALL PROPOSED STOP SIGN WITH CROSS TRAFFIC DOES NOT STOP PLAQUE AS SHOWN. THE STOP SIGN WILL HAVE AN LED RING AND WILL NEED TO HAVE THE POST 12" TALLER THAN THE TOP OF THE SIGN FOR BEACON INSTALLATION. STATE FORCES WILL COME IN AND INSTALL THE RING ASSEMBLY FOR THIS AFTER THE CONTRACTOR HAS MOUNTED THE SIGN.
- 2.) ENSURE 7' MIN CLEARANCE AND 7.5' MAX VERTICAL CLEARANCE TO BOTTOM OF SUPPLEMENTAL PLAQUE (CROSS TRAFFIC DOES NOT STOP). REFER TO SIGN STANDARD SMD (GEN)-08 FOR SIGN PLACEMENT DETAILS.
- 3.) REMOVE EXISTING STOP AHEAD SIGN AND POST ON THE APPROACH AS SHOWN. INSTALL STOP AHEAD SIGNS IN A RANGE OF A MINIMUM DISTANCE OF 975' TO 1150'. MAINTAIN A MINIMUM 325' SPACING BETWEEN EXISTING SIGNS.
- 4.) INSTALLED SIGN ASSEMBLIES WILL REQUIRE OMNI-DIRECTIONAL POST WRAP. THIS WRAP WILL BE SUBSIDIARY TO ITEM 644. REFERENCE ITEM 644 SMALL ROADSIDE SIGN ASSEMBLIES IN THE GENERAL NOTES FOR MORE INFORMATION.
- 5.) RESTRIPE EXISTING STOP BAR IN PLACE.

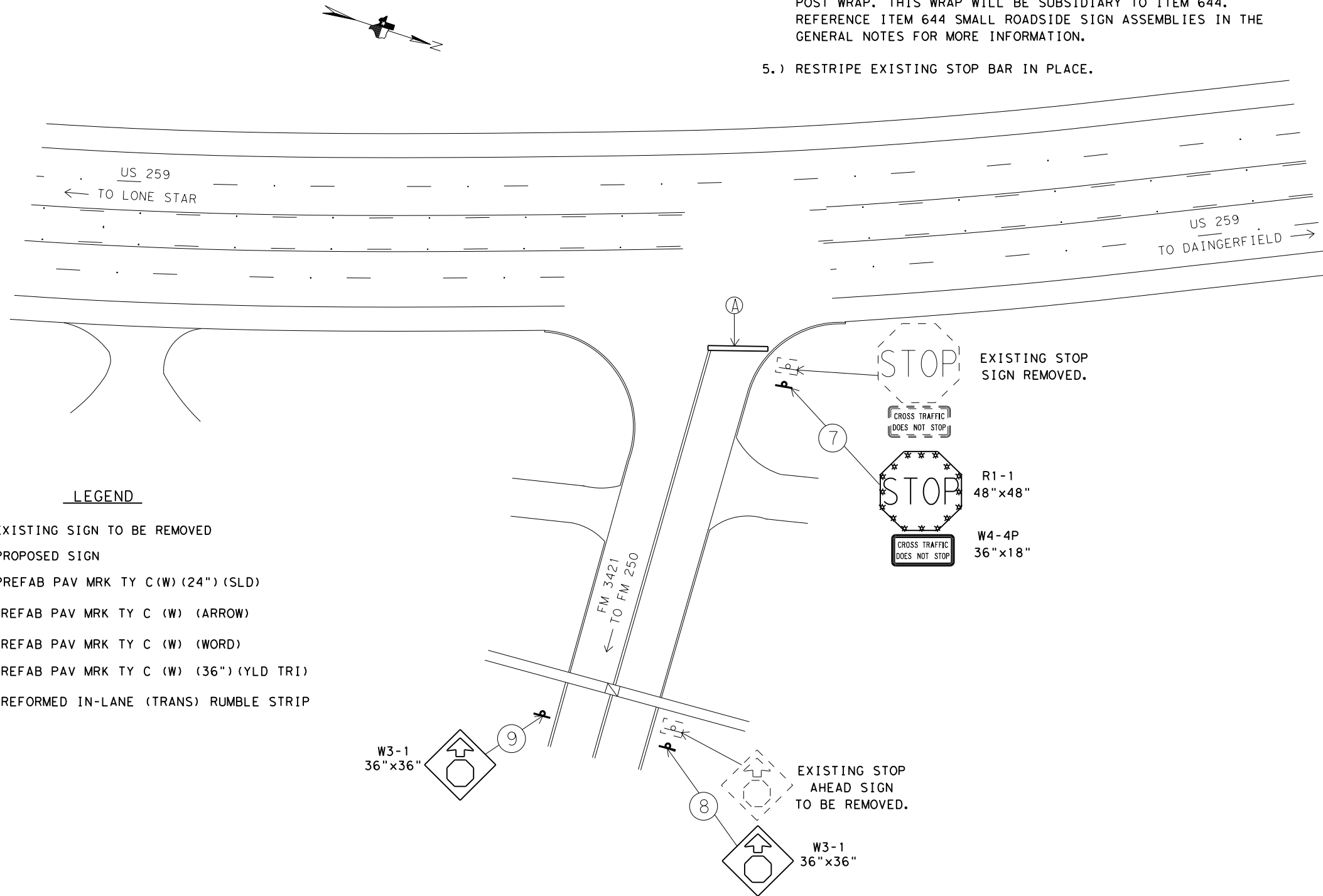

LEGEND

- EXISTING SIGN TO BE REMOVED
- PROPOSED SIGN
- PREFAB PAV MRK TY C (W) (24") (SLD)
- PREFAB PAV MRK TY C (W) (ARROW)
- PREFAB PAV MRK TY C (W) (WORD)
- PREFAB PAV MRK TY C (W) (36") (YLD TRI)
- PREFORMED IN-LANE (TRANS) RUMBLE STRIP

KENNETH S. BURNS
 142417
 LICENSED PROFESSIONAL ENGINEER
 Kenneth S. Burns, P.E.
 1/30/2024













**PROPOSED
 SIGN AND
 PAVEMENT MARKING
 LAYOUT
 US 259 AT FM 3421**

FHWA TEXAS DIVISION		CONSTRUCTION PROJECT NO.		SHEET NO.
				59
STATE	DISTRICT	COUNTY		
TEXAS	ATL	MORRIS		
CONTROL	SECTION	JOB	HIGHWAY NO.	
0010	08	060	US 67	

NOT TO SCALE

FILE: T:\engdata\Traffic\DGN\192515 Jamie\JOBS\LIGHTING PROJECTS\Lighting Project May 2024\Intersections\SH 155 AT FM 2911\SH 155 AT FM 2911.dgn
 DATE: 1/25/2024 9:20:17 AM

LEGEND

-  RDWY ILL ASSEM W/RIPRAP APRON
-  GROUND BOX (TY D) (162922) W/APRON
-  GROUND BOX (TY A) (122311) W/APRON
-  GROUND BOX (TY A) (122311)
-  TRENCHED CONDUIT
-  BORED CONDUIT
-  OVERHEAD POWER LINE
-  WIRE RUN NUMBER
-  LUMINAIRE CIRCUIT & POLE NUMBER
-  ELECTRICAL SERVICE
-  TELEPHONE AND/OR POWER POLE
-  CULVERT
-  DRAINAGE PIPE

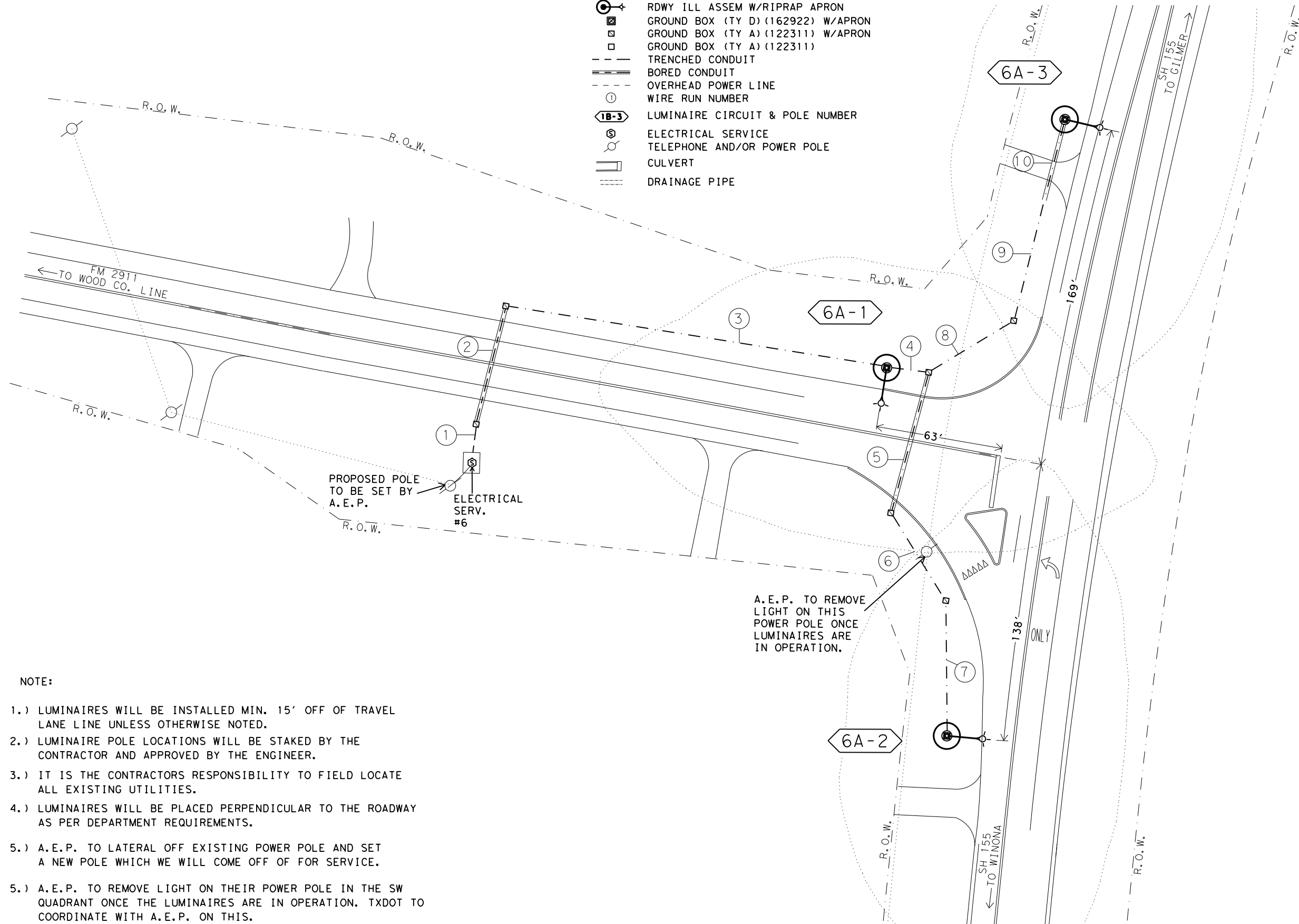

NOTE:

- 1.) LUMINAIRES WILL BE INSTALLED MIN. 15' OFF OF TRAVEL LANE LINE UNLESS OTHERWISE NOTED.
- 2.) LUMINAIRE POLE LOCATIONS WILL BE STAKED BY THE CONTRACTOR AND APPROVED BY THE ENGINEER.
- 3.) IT IS THE CONTRACTORS RESPONSIBILITY TO FIELD LOCATE ALL EXISTING UTILITIES.
- 4.) LUMINAIRES WILL BE PLACED PERPENDICULAR TO THE ROADWAY AS PER DEPARTMENT REQUIREMENTS.
- 5.) A.E.P. TO LATERAL OFF EXISTING POWER POLE AND SET A NEW POLE WHICH WE WILL COME OFF OF FOR SERVICE.
- 5.) A.E.P. TO REMOVE LIGHT ON THEIR POWER POLE IN THE SW QUADRANT ONCE THE LUMINAIRES ARE IN OPERATION. TXDOT TO COORDINATE WITH A.E.P. ON THIS.

A.E.P. TO REMOVE LIGHT ON THIS POWER POLE ONCE LUMINAIRES ARE IN OPERATION.

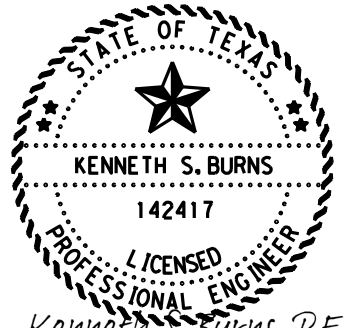

Kenneth S. Burns, P.E.
 1/30/2024

PROPOSED ILLUMINATION LAYOUT SH 155 AT FM 2911

© 2024 Texas Department of Transportation
 SHEET 1 OF 2

FHWA TEXAS DIVISION		CONSTRUCTION PROJECT NO.		SHEET NO.
				60
STATE	DISTRICT	COUNTY		
TEXAS	ATL	MORRIS		
CONTROL	SECTION	JOB	HIGHWAY NO.	
0010	08	060	US 67	

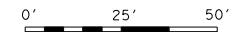

FILE: T:\engdata\Traffic\DGN\192515 Jamie\JOBS\LIGHTING PROJECTS\Lighting Project May 2024\Intersections\SH 155 AT FM 2911\SH 155 AT FM 2911.dgn
 DATE: 1/25/2024 9:21:55 AM

CONDUIT AND CONDUCTOR RUNS FOR ILLUMINATION										
RUN NO.	CONDUIT 2" PVC		TYP D GROUND BOX		TYP A GROUND BOX		CONDUCTORS			
	BORED (LF)	TRENCHED (LF)	APRON NONE	APRON NONE	#6 INSULATED NO. OF CONDUCTORS	LF	#6 BARE NO. OF CONDUCTORS	LF		
1		19			1		2	58	1	29
2	61				1		2	132	1	66
3		191					2	392	1	196
4		21			1		2	52	1	26
5	72				1		2	154	1	77
6		51			1		2	112	1	56
7		67					2	144	1	72
8		49			1		2	108	1	54
9		62					2	124	1	62
10	41						2	92	1	46
TOTALS	174	460			6			1368		684

* CALCULATIONS FOR WIRE TOTALS:
 -5' OF SLACK FOR GROUND BOXES. (PER CONDUCTOR)
 -5' OF SLACK FOR WIRE IN THE SERVICE. (PER CONDUCTOR)
 -5' OF SLACK FOR WIRE IN THE BASE OF ILLUMINATION POLES. (PER CONDUCTOR)

SUMMARY OF QUANTITIES-ILLUMINATION				
ITEM	DESC CODE	DESCRIPTION	UNIT	TOTAL
0416	6029	DRILL SHAFT (RDWY ILL POLE) (30 IN)	LF	30
0432	6006	RIPRAP (CONC) (CL B)	CY	2
0610	6288	IN RD IL (TY SA) 50T-10 (400W EQ) LED	EA	3
0618	6023	CONDT (PVC) (SCHD 40) (2")	LF	460
0618	6024	CONDT (PVC) (SCHD 40) (2") (BORE)	LF	174
0620	6009	ELEC CONDR (NO. 6) BARE	LF	684
0620	6010	ELEC CONDR (NO. 6) INSULATED	LF	1368
0624	6002	GROUND BOX TY A (122311) W/APRON	EA	6
0628	6004	ELC SRV TY A 120/240 060 (NS) AL (E) SP (0)	EA	1
6185	6002	TMA (STATIONARY)	DAY	8

ROADWAY ILLUMINATION ASSEMBLY SUMMARY			
POLE	TYPE	FND. (LF)	REMARKS
6A-1	(TY SA) 50T-10 (400W EQ) LED	10	18' OFF TRAVEL LANE
6A-2	(TY SA) 50T-10 (400W EQ) LED	10	15' OFF TRAVEL LANE
6A-3	(TY SA) 50T-10 (400W EQ) LED	10	15' OFF TRAVEL LANE

NOTE:

- LUMINAIRES WILL BE INSTALLED MIN. 15' OFF OF TRAVEL LANE LINE UNLESS OTHERWISE NOTED.
- LUMINAIRE POLE LOCATIONS WILL BE STAKED BY THE CONTRACTOR AND APPROVED BY THE ENGINEER.
- IT IS THE CONTRACTORS RESPONSIBILITY TO FIELD LOCATE ALL EXISTING UTILITIES.
- LUMINAIRES WILL BE PLACED PERPENDICULAR TO THE ROADWAY AS PER DEPARTMENT REQUIREMENTS.

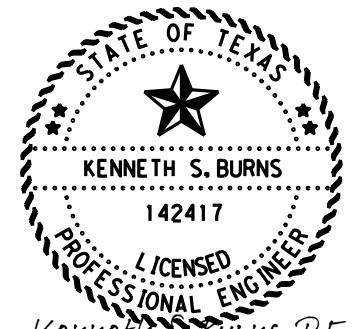

Kenneth S. Burns, P.E.

1/30/2024

PROPOSED ILLUMINATION LAYOUT SH 155 AT FM 2911













© 2024 Texas Department of Transportation
 SHEET 2 OF 2

FHWA TEXAS DIVISION		CONSTRUCTION PROJECT NO.		SHEET NO.
				61
STATE	DISTRICT	COUNTY		
TEXAS	ATL	MORRIS		
CONTROL	SECTION	JOB	HIGHWAY NO.	
0010	08	060	US 67	

NOT TO SCALE

FILE: T:\engdata\Traffic\DN\192515 Jamie\JOBS\LIGHTING PROJECTS\Lighting Project May 2024\Intersections\FM 127 AT FM 2882\FM 127 AT FM 2882.dgn
 DATE: 1/25/2024 9:22:51 AM

LEGEND

-  RDWY ILL ASSEM W/RIPRAP APRON
-  GROUND BOX (TY D) (162922) W/APRON
-  GROUND BOX (TY A) (122311) W/APRON
-  GROUND BOX (TY A) (122311)
-  TRENCHED CONDUIT
-  BORED CONDUIT
-  OVERHEAD POWER LINE
-  WIRE RUN NUMBER
-  LUMINAIRE CIRCUIT & POLE NUMBER
-  ELECTRICAL SERVICE
-  TELEPHONE AND/OR POWER POLE
-  CULVERT
-  DRAINAGE PIPE

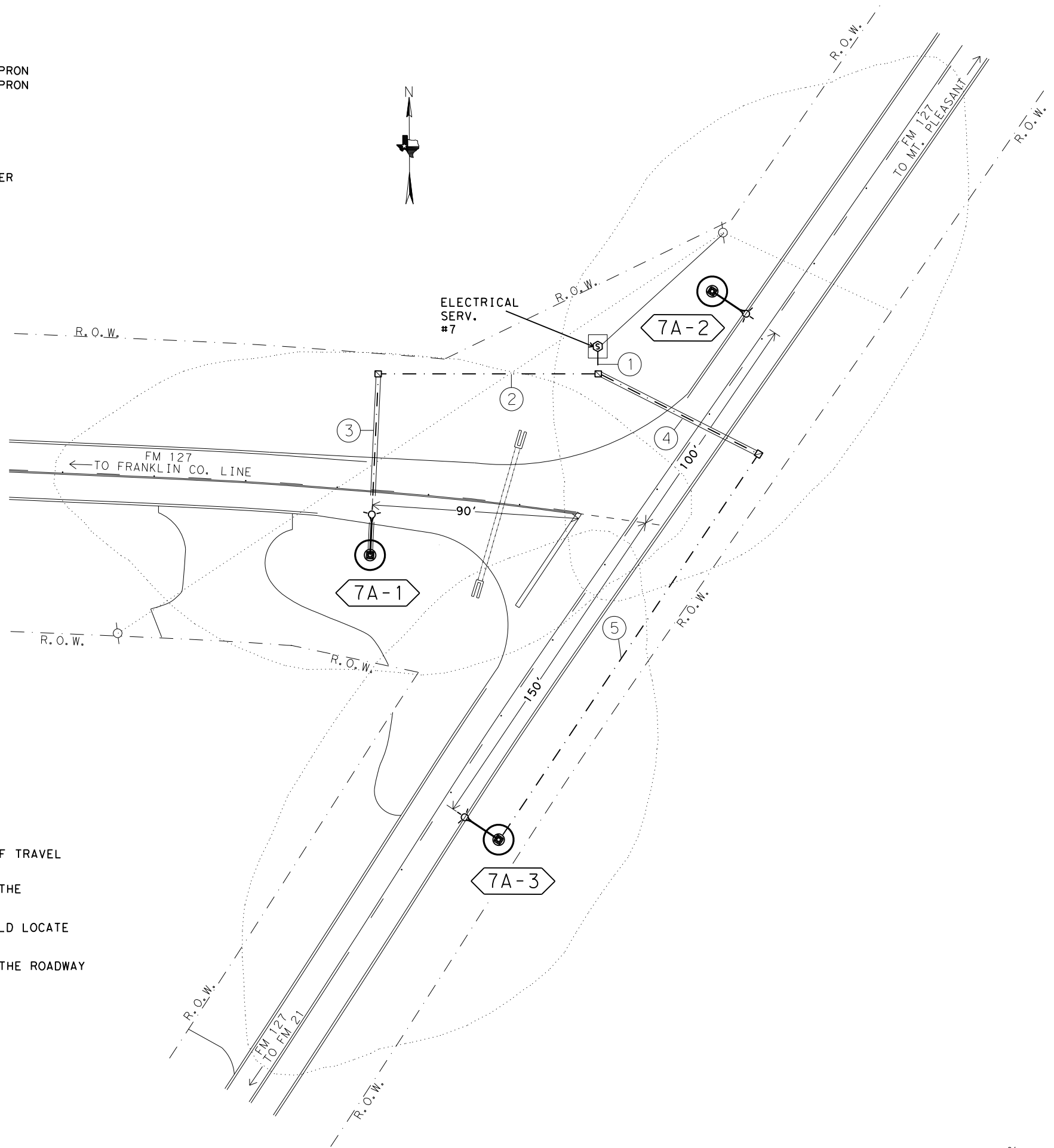

NOTE:

- 1.) LUMINAIRES WILL BE INSTALLED MIN. 15' OFF OF TRAVEL LANE LINE UNLESS OTHERWISE NOTED.
- 2.) LUMINAIRE POLE LOCATIONS WILL BE STAKED BY THE CONTRACTOR AND APPROVED BY THE ENGINEER.
- 3.) IT IS THE CONTRACTORS RESPONSIBILITY TO FIELD LOCATE ALL EXISTING UTILITIES.
- 4.) LUMINAIRES WILL BE PLACED PERPENDICULAR TO THE ROADWAY AS PER DEPARTMENT REQUIREMENTS.

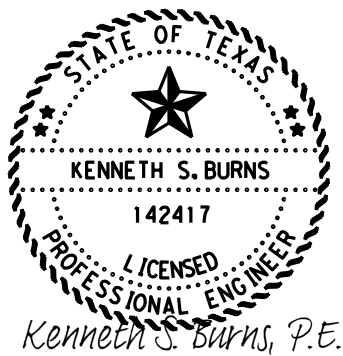

1/30/2024

**PROPOSED ILLUMINATION LAYOUT
 FM 127 AT FM 2882**

© 2024 Texas Department of Transportation
 SHEET 1 OF 2

FHWA TEXAS DIVISION		CONSTRUCTION PROJECT NO.		SHEET NO.	
				62	
STATE	DISTRICT	COUNTY			
TEXAS	ATL	MORRIS			
CONTROL	SECTION	JOB	HIGHWAY NO.		
0010	08	060	US 67		

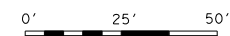

FILE: T:\engdata\Traffic\DGN\192515 Jamie\JOBS\LIGHTING PROJECTS\Lighting Project May 2024\Intersections\FM 127 AT FM 2882\FM 127 AT FM 2882.dgn
 DATE: 1/25/2024 9:23:47 AM

CONDUIT AND CONDUCTOR RUNS FOR ILLUMINATION								
RUN NO.	CONDUIT 2" PVC		TYP D GROUND BOX	TYP A GROUND BOX	CONDUCTORS			
	BORED (LF)	TRENCHED (LF)	APRON NONE	APRON NONE	#6 INSULATED		#6 BARE	
					NO. OF CONDUCTORS	LF	NO. OF CONDUCTORS	LF
1		12		1	2	44	1	22
2		96		1	2	202	1	101
3	79				2	168	1	84
4	78			1	2	166	1	83
5		203			2	416	1	208
TOTALS	157	311		3		996		498

* CALCULATIONS FOR WIRE TOTALS:
 -5' OF SLACK FOR GROUND BOXES. (PER CONDUCTOR)
 -5' OF SLACK FOR WIRE IN THE SERVICE. (PER CONDUCTOR)
 -5' OF SLACK FOR WIRE IN THE BASE OF ILLUMINATION POLES. (PER CONDUCTOR)

SUMMARY OF QUANTITIES-ILLUMINATION				
ITEM	DESC CODE	DESCRIPTION	UNIT	TOTAL
0416	6029	DRILL SHAFT (RDWY ILL POLE) (30 IN)	LF	30
0432	6006	RIPRAP (CONC) (CL B)	CY	2
0610	6288	IN RD IL (TY SA) 50T-10 (400W EQ) LED	EA	3
0618	6023	CONDT (PVC) (SCHD 40) (2")	LF	311
0618	6024	CONDT (PVC) (SCHD 40) (2") (BORE)	LF	157
0620	6009	ELEC CONDR (NO. 6) BARE	LF	498
0620	6010	ELEC CONDR (NO. 6) INSULATED	LF	996
0624	6002	GROUND BOX TY A (122311) W/APRON	EA	3
0628	6004	ELC SRV TY A 120/240 060 (NS) AL (E) SP (O)	EA	1
6185	6002	TMA (STATIONARY)	DAY	8

ROADWAY ILLUMINATION ASSEMBLY SUMMARY			
POLE	TYPE	FND. (LF)	REMARKS
7A-1	(TY SA) 50T-10 (400W EQ) LED	10	14' OFF TRAVEL LANE
7A-2	(TY SA) 50T-10 (400W EQ) LED	10	15' OFF TRAVEL LANE
7A-3	(TY SA) 50T-10 (400W EQ) LED	10	15' OFF TRAVEL LANE

NOTE:

- LUMINAIRES WILL BE INSTALLED MIN. 15' OFF OF TRAVEL LANE LINE UNLESS OTHERWISE NOTED.
- LUMINAIRE POLE LOCATIONS WILL BE STAKED BY THE CONTRACTOR AND APPROVED BY THE ENGINEER.
- IT IS THE CONTRACTORS RESPONSIBILITY TO FIELD LOCATE ALL EXISTING UTILITIES.
- LUMINAIRES WILL BE PLACED PERPENDICULAR TO THE ROADWAY AS PER DEPARTMENT REQUIREMENTS.

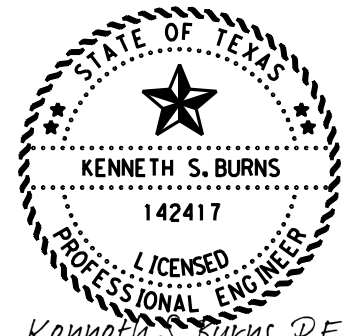

Kenneth S. Burns, P.E.

1/30/2024

PROPOSED ILLUMINATION LAYOUT
FM 127 AT FM 2882

© 2024 Texas Department of Transportation
 SHEET 2 OF 2

FHWA TEXAS DIVISION		CONSTRUCTION PROJECT NO.		SHEET NO.
				63
STATE	DISTRICT	COUNTY		
TEXAS	ATL	MORRIS		
CONTROL	SECTION	JOB	HIGHWAY NO.	
0010	08	060	US 67	

NOT TO SCALE

FILE: T:\engdata\Traffic\DGN\192515_Jamie\JOBS\LIGHTING PROJECTS\Lighting Project May 2024\Intersections\FM 3358 AT FM 726\FM 3358 AT FM 726.dgn
 DATE: 1/25/2024 9:24:40 AM

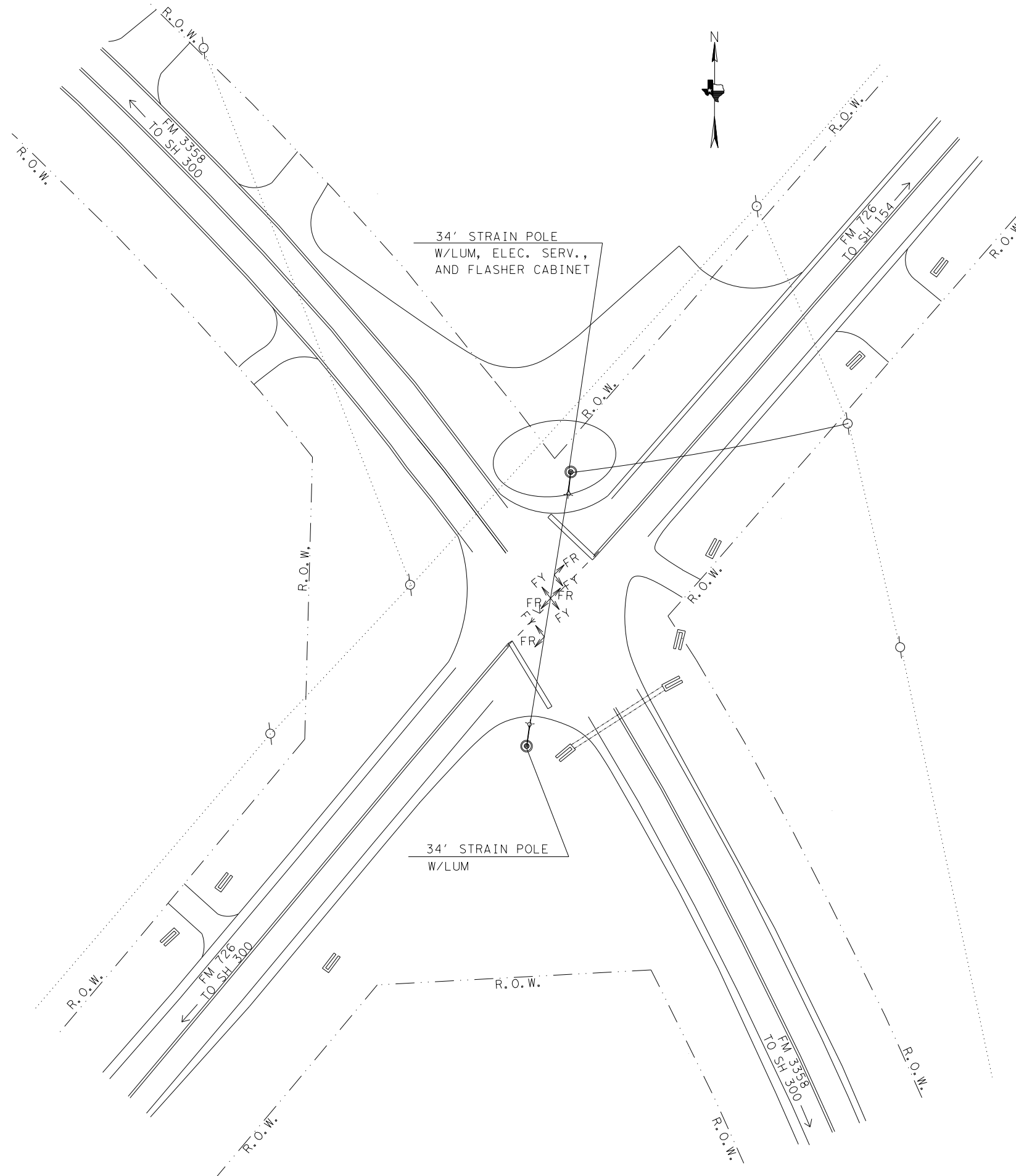

LEGEND

- TELEPHONE AND/OR POWER POLE
- POWER LINE
- 34' STRAIN POLE w/ LUM
- FLASHING BEACON AND COLOR
- CULVERT
- DRAINAGE PIPE

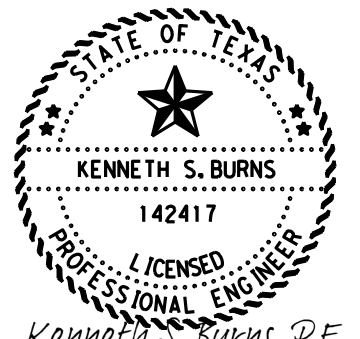

Kenneth S. Burns, P.E.

1/30/2024

**EXISTING CONDITION
 LAYOUT
 FM 3358 AT FM 726**





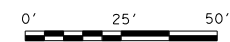



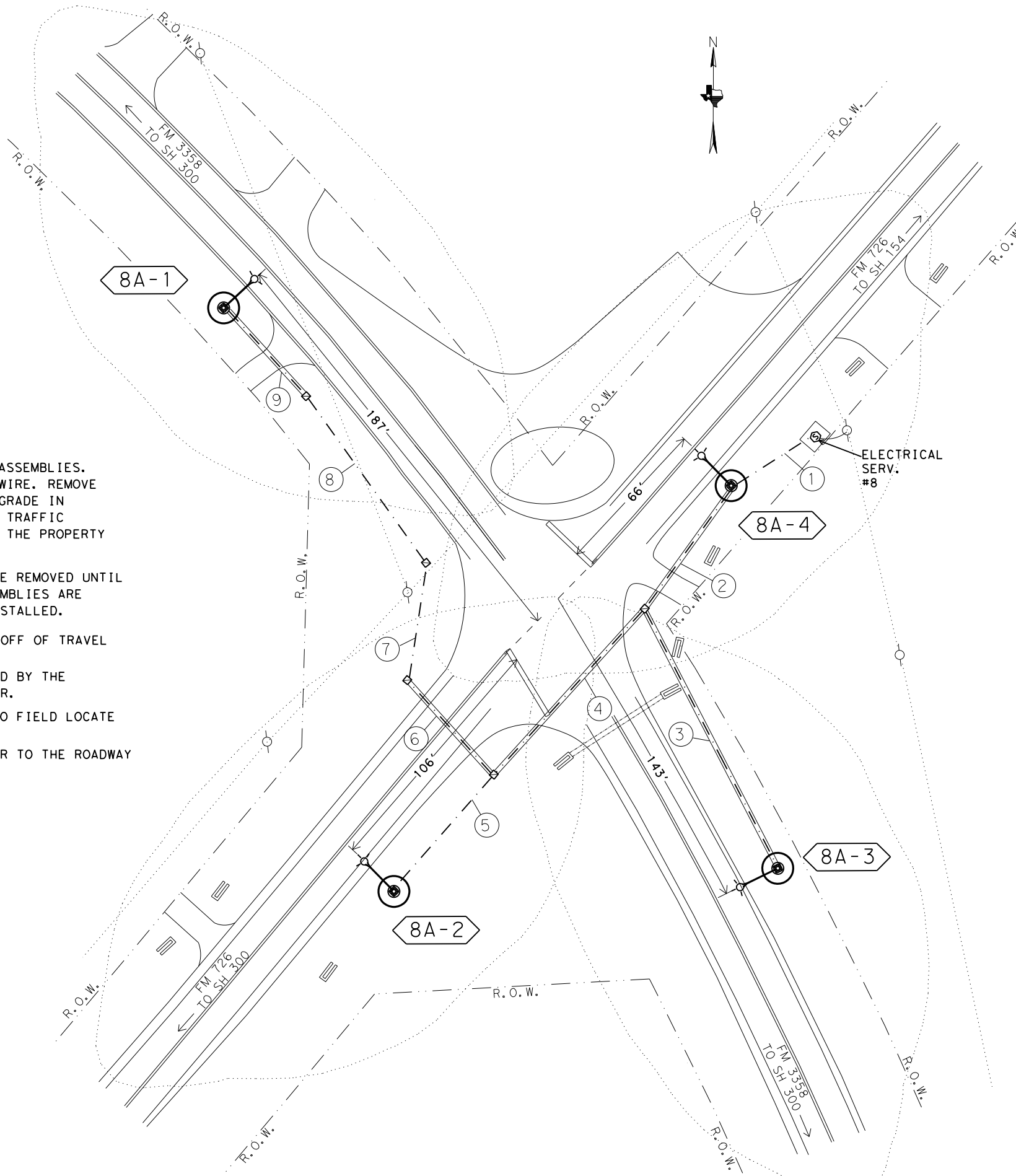





FHWA TEXAS DIVISION		CONSTRUCTION PROJECT NO.		SHEET NO.
				64
STATE	DISTRICT	COUNTY		
TEXAS	ATL	MORRIS		
CONTROL	SECTION	JOB	HIGHWAY NO.	
0010	08	060	US 67	



FILE: T:\engdata\Traffic\DN\192515 Jamie\JOBS\LIGHTING PROJECTS\Lighting Project May 2024\Intersections\FM 3358 AT FM 726\FM 3358 AT FM 726.dgn
 DATE: 1/25/2024 9:25:27 AM



LEGEND

-  RDWY ILL ASSEM W/RIPRAP APRON
-  GROUND BOX (TY D) (162922) W/APRON
-  GROUND BOX (TY A) (122311) W/APRON
-  GROUND BOX (TY A) (122311)
-  TRENCHED CONDUIT
-  BORED CONDUIT
-  OVERHEAD POWER LINE
-  WIRE RUN NUMBER
-  LUMINAIRE CIRCUIT & POLE NUMBER
-  ELECTRICAL SERVICE
-  TELEPHONE AND/OR POWER POLE
-  CULVERT
-  DRAINAGE PIPE

NOTE:

- 1.) INSTALL PROPOSED ROADWAY ILLUMINATION ASSEMBLIES. REMOVE EXISTING STRAIN POLES AND SPAN WIRE. REMOVE FOUNDATIONS FOR STRAIN POLES 2' BELOW GRADE IN ACCORDANCE WITH ITEM 680 6004 REMOVING TRAFFIC SIGNALS. ALL REMOVAL ITEMS WILL BECOME THE PROPERTY OF THE CONTRACTOR UPON REMOVAL.
- 2.) OVERHEAD FLASHING BEACONS ARE NOT TO BE REMOVED UNTIL THE PROPOSED ROADWAY ILLUMINATION ASSEMBLIES ARE FUNCTIONING AND PROPOSED STOP SIGNS INSTALLED.
- 3.) LUMINAIRE POLE LOCATIONS WILL BE STAKED BY THE CONTRACTOR AND APPROVED BY THE ENGINEER.
- 4.) LUMINAIRE POLE LOCATIONS WILL BE STAKED BY THE CONTRACTOR AND APPROVED BY THE ENGINEER.
- 5.) IT IS THE CONTRACTORS RESPONSIBILITY TO FIELD LOCATE ALL EXISTING UTILITIES.
- 6.) LUMINAIRE POLE LOCATIONS WILL BE STAKED BY THE CONTRACTOR AND APPROVED BY THE ENGINEER.

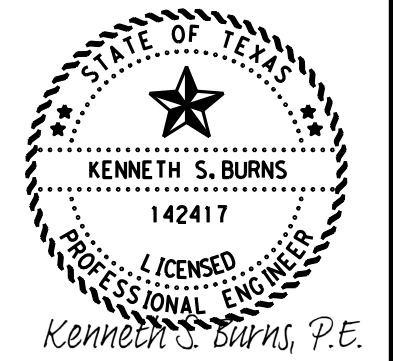

1/30/2024

**PROPOSED
ILLUMINATION
LAYOUT
FM 3358 AT FM 726**

© 2024 Texas Department of Transportation
SHEET 1 OF 2

FHWA TEXAS DIVISION		CONSTRUCTION PROJECT NO.		SHEET NO.	
				65	
STATE	DISTRICT	COUNTY			
TEXAS	ATL	MORRIS			
CONTROL	SECTION	JOB	HIGHWAY NO.		
0010	08	060	US 67		

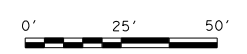

FILE: T:\engdata\Traffic\DN\192515 Jamie\JOBS\LIGHTING PROJECTS\Lighting Project May 2024\Intersections\FM 3358 AT FM 726.dgn
 DATE: 1/30/2024 10:11:45 AM

CONDUIT AND CONDUCTOR RUNS FOR ILLUMINATION										
RUN NO.	CONDUIT 2" PVC		TYP D GROUND BOX		TYP A GROUND BOX		CONDUCTORS			
	BORED (LF)	TRENCHED (LF)	APRON	NONE	APRON	NONE	#6 INSULATED		#6 BARE	
							NO. OF CONDUCTORS	LF	NO. OF CONDUCTORS	LF
1		41					2	102	1	51
2	63				1		2	136	1	68
3	123						2	256	1	128
4	94				1		2	198	1	99
5		65					2	140	1	70
6	54				1		2	118	1	59
7		50			1		2	110	1	55
8		87			1		2	184	1	92
9	51						2	112	1	56
TOTALS	385	243			5			1356		678

* CALCULATIONS FOR WIRE TOTALS:
 -5' OF SLACK FOR GROUND BOXES. (PER CONDUCTOR)
 -5' OF SLACK FOR WIRE IN THE SERVICE. (PER CONDUCTOR)
 -5' OF SLACK FOR WIRE IN THE BASE OF ILLUMINATION POLES. (PER CONDUCTOR)

ROADWAY ILLUMINATION ASSEMBLY SUMMARY			
POLE	TYPE	FND. (LF)	REMARKS
8A-1	(TY SA)50T-10(400W EQ)LED	10	15' OFF TRAVEL LANE
8A-2	(TY SA)50T-10(400W EQ)LED	10	15' OFF TRAVEL LANE
8A-3	(TY SA)50T-10(400W EQ)LED	10	15' OFF TRAVEL LANE
8A-4	(TY SA)50T-10(400W EQ)LED	10	10' OFF TRAVEL LANE

SUMMARY OF QUANTITIES-ILLUMINATION				
ITEM	DESC CODE	DESCRIPTION	UNIT	TOTAL
0416	6029	DRILL SHAFT (RDWY ILL POLE) (30 IN)	LF	40
0432	6006	RIPRAP (CONC) (CL B)	CY	2
0610	6288	IN RD IL (TY SA)50T-10(400W EQ)LED	EA	4
0618	6023	CONDT (PVC) (SCHD 40) (2")	LF	243
0618	6024	CONDT (PVC) (SCHD 40) (2") (BORE)	LF	385
0620	6009	ELEC CONDR (NO. 6) BARE	LF	678
0620	6010	ELEC CONDR (NO. 6) INSULATED	LF	1356
0624	6002	GROUND BOX TY A (122311)W/APRON	EA	5
0628	6004	ELC SRV TY A 120/240_060(NS)AL(E)SP(O)	EA	1
0680	6004	REMOVING TRAFFIC SIGNALS	EA	1
6185	6002	TMA (STATIONARY)	DAY	8

- 1.) INSTALL PROPOSED ROADWAY ILLUMINATION ASSEMBLIES. REMOVE EXISTING STRAIN POLES AND SPAN WIRE. REMOVE FOUNDATIONS FOR STRAIN POLES 2' BELOW GRADE IN ACCORDANCE WITH ITEM 680 6004 REMOVING TRAFFIC SIGNALS. ALL REMOVAL ITEMS WILL BECOME THE PROPERTY OF THE CONTRACTOR UPON REMOVAL.
- 2.) OVERHEAD FLASHING BEACONS ARE NOT TO BE REMOVED UNTIL THE PROPOSED ROADWAY ILLUMINATION ASSEMBLIES ARE FUNCTIONING AND PROPOSED STOP SIGNS INSTALLED.
- 3.) LUMINAIRES WILL BE INSTALLED MIN. 15' OFF OF TRAVEL LANE LINE UNLESS OTHERWISE NOTED.
- 4.) LUMINAIRE POLE LOCATIONS WILL BE STAKED BY THE CONTRACTOR AND APPROVED BY THE ENGINEER.
- 5.) IT IS THE CONTRACTORS RESPONSIBILITY TO FIELD LOCATE ALL EXISTING UTILITIES.
- 6.) LUMINAIRES WILL BE PLACED PERPENDICULAR TO THE ROADWAY AS PER DEPARTMENT REQUIREMENTS.

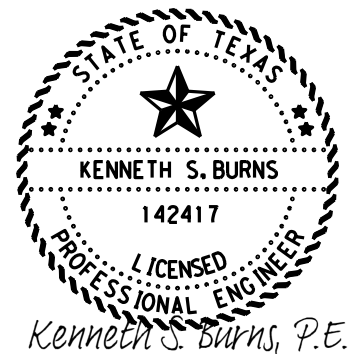

Kenneth S. Burns, P.E.

1/30/2024

PROPOSED ILLUMINATION LAYOUT
FM 3358 AT FM 726

© 2024 Texas Department of Transportation
 SHEET 2 OF 2

FHWA TEXAS DIVISION		CONSTRUCTION PROJECT NO.		SHEET NO.
				66
STATE	DISTRICT	COUNTY		
TEXAS	ATL	MORRIS		
CONTROL	SECTION	JOB	HIGHWAY NO.	
0010	08	060	US 67	

NOT TO SCALE

T:\engdata\Traffic\Lighting\Projects\Project May 2024\Intersections\FM 3358 AT FM 726\FM 3358 AT FM 726.dgn
 FILE: 1/25/2024 9:28:34 AM

LEGEND

- EXISTING SIGN TO BE REMOVED
- PROPOSED SIGN
- PREFAB PAV MRK TY C(W) (24") (SLD)
- PREFAB PAV MRK TY C (W) (ARROW)
- PREFAB PAV MRK TY C (W) (WORD)
- PREFAB PAV MRK TY C (W) (36") (YLD TRI)
- PREFORMED IN-LANE (TRANS) RUMBLE STRIP

NOTE:

- 1.) INTERSECTION IS CURRENTLY A STOP CONDITION FOR FM 726. THIS INTERSECTION WILL BE CONVERTED TO AN ALL WAY STOP CONDITION. INTERSECTION WILL NOT BE CONVERTED TO AN ALL WAY STOP CONDITION UNTIL PROPOSED ROADWAY ILLUMINATION IS INSTALLED AND ALL SIGNS AND PAVEMENT MARKINGS SHOWN ARE IN PLACE.
- 2.) PORTABLE CHANGEABLE MESSAGE BOARDS WILL BE REQUIRED FOR CONVERSION TO AN ALL WAY STOP CONDITION. MESSAGE BOARDS WILL BE NEEDED ON ALL APPROACHES RUNNING 5 DAYS PRIOR TO CONVERSION. MESSAGE BOARDS WILL REMAIN IN PLACE FOR 7 DAYS AFTER CONVERSION TO ALL WAY STOP CONDITION. MESSAGES AND PLACEMENT WILL BE AS DIRECTED BY THE ENGINEER.
- 3.) REMOVE EXISTING STOP SIGNS. INSTALL PROPOSED STOP SIGNS WITH ALL WAY PLAQUES AS SHOWN. THE STOP SIGNS SHOWN WITH THE LED RING WILL NEED TO HAVE THE POST 12" TALLER THAN THE TOP OF THE SIGN FOR BEACON INSTALLATION. STATE FORCES WILL COME IN AND INSTALL THE RING ASSEMBLIES FOR THIS AFTER THE CONTRACTOR HAS MOUNTED THE SIGNS.
- 4.) ENSURE 7' MIN CLEARANCE AND 7.5' MAX VERTICAL CLEARANCE TO BOTTOM OF SUPPLEMENTAL PLAQUE (CROSS TRAFFIC DOES NOT STOP). REFER TO SIGN STANDARD SMD (GEN)-08 FOR SIGN PLACEMENT DETAILS.
- 5.) REMOVE EXISTING STOP AHEAD SIGNS AND POSTS ON THE APPROACHES AS SHOWN. INSTALL STOP AHEAD SIGNS IN A RANGE OF A MINIMUM DISTANCE OF 975' TO 1150'. MAINTAIN A MINIMUM 325' SPACING BETWEEN EXISTING SIGNS. INSTALL STOP AHEAD SIGNS ON FM 3358 AT THE DISTANCES SHOWN.
- 6.) INSTALLED SIGN ASSEMBLIES WILL REQUIRE OMNI-DIRECTIONAL POST WRAP. THIS WRAP WILL BE SUBSIDIARY TO ITEM 644. REFERENCE ITEM 644 SMALL ROADSIDE SIGN ASSEMBLIES IN THE GENERAL NOTES FOR MORE INFORMATION.
- 7.) RESTRIPE EXISTING STOP BARS IN PLACE AND INSTALL PROPOSED STOP BARS ON FM 3358. STOP BAR PLACEMENT FOR THESE TO BE VERIFIED BY THE ENGINEER OR THEIR REPRESENTATIVE PRIOR TO PLACEMENT. INSTALL STOP AHEAD PAVEMENT MARKINGS ON ALL OF THE APPROACHES.

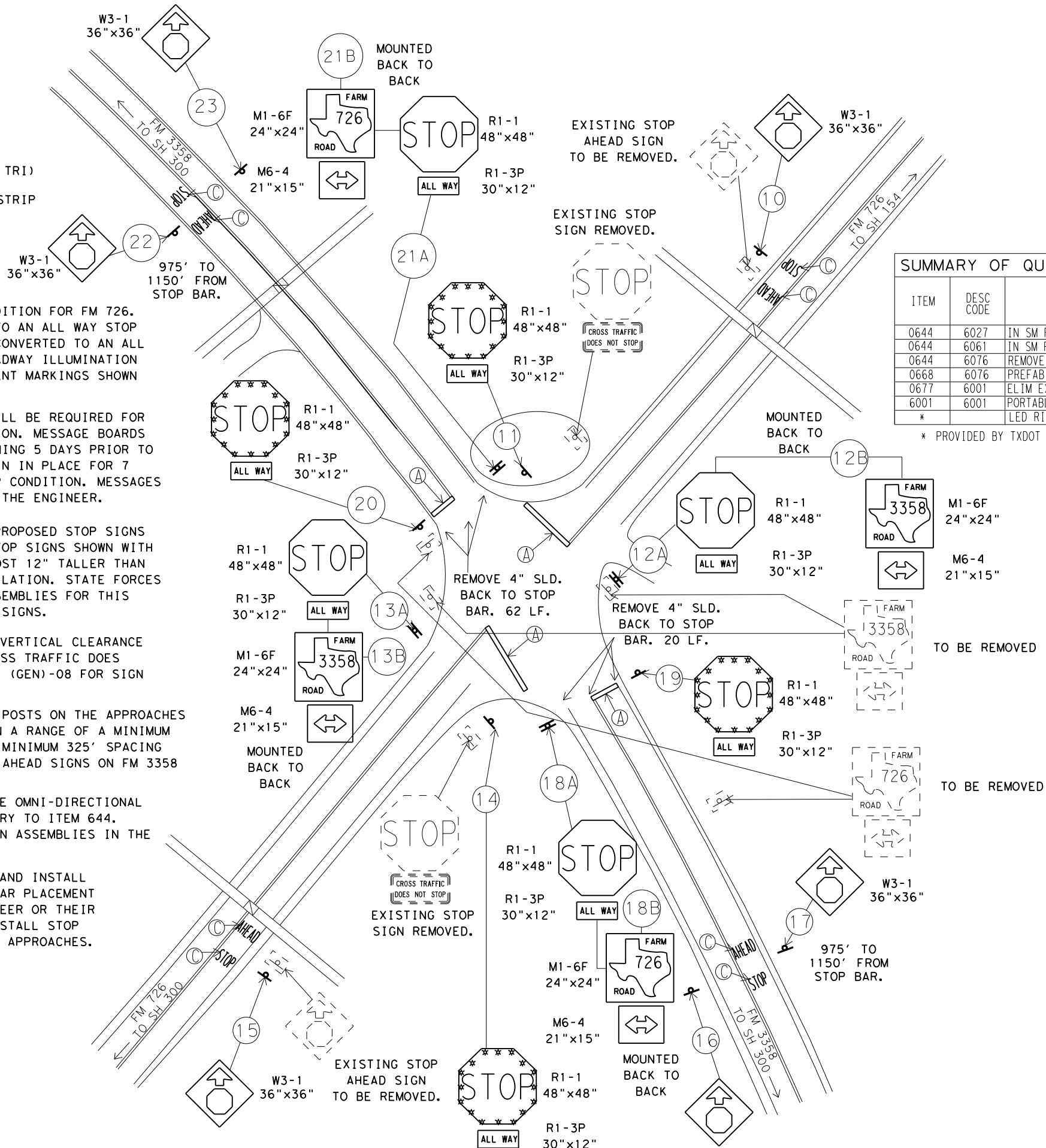

ITEM	DESC CODE	DESCRIPTION	UNIT	TOTAL
0644	6027	IN SM RD SN SUP&AM TY S80(1)SA(P)	EA	8
0644	6061	IN SM RD SN SUP&AM TY TWT(1)WS(T)	EA	6
0644	6076	REMOVE SM RD SN SUP&AM	EA	8
0668	6076	PREFAB PAV MRK TY C (W) (24") (SLD)	LF	84
0677	6001	ELIM EXT PAV MRK & MRKS (4")	LF	82
6001	6001	PORTABLE CHANGEABLE MESSAGE SIGNS	DAY	48
*		LED RING	EA	4

* PROVIDED BY TXDOT AND INSTALLED BY TXDOT.

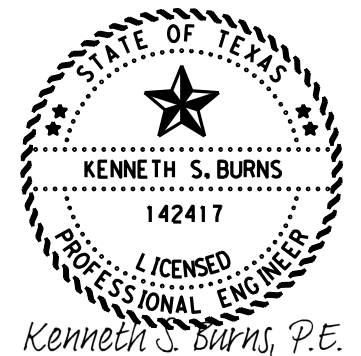

Kenneth S. Burns, P.E.

1/30/2024

**PROPOSED
SIGN AND
PAVEMENT MARKING
LAYOUT
FM 3358 AT FM 726**

© 2024 Texas Department of Transportation

FHWA TEXAS DIVISION	CONSTRUCTION PROJECT NO.	SHEET NO.
		67
STATE	DISTRICT	COUNTY
TEXAS	ATL	MORRIS
CONTROL	SECTION	JOB
0010	08	060
		HIGHWAY NO.
		US 67

NOT TO SCALE

FILE: T:\engdata\Traffic\DGN\192515_Jamie\JOBS\LIGHTING PROJECTS\Lighting Project May 2024\Intersections\FM 1845 at FM 1844\FM 1845 at FM 1844.dgn
 DATE: 1/25/2024 9:30:19 AM

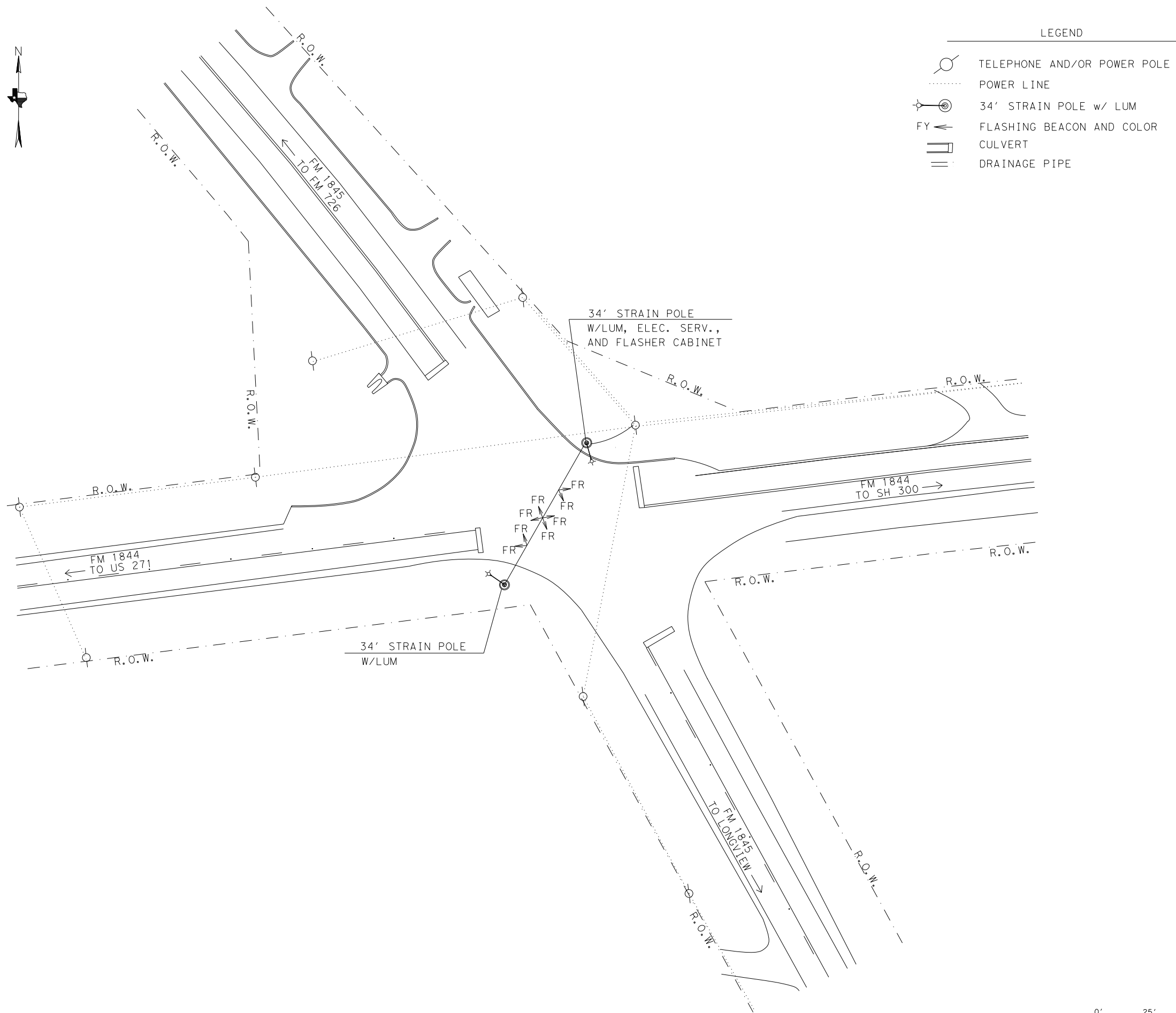

STATE OF TEXAS
 KENNETH S. BURNS
 142417
 LICENSED PROFESSIONAL ENGINEER
 Kenneth S. Burns, P.E.

1/30/2024

**EXISTING CONDITION LAYOUT
 FM 1845 AT FM 1844**

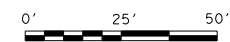

FHWA TEXAS DIVISION		CONSTRUCTION PROJECT NO.		SHEET NO.
				68
STATE	DISTRICT	COUNTY		
TEXAS	ATL	MORRIS		
CONTROL	SECTION	JOB	HIGHWAY NO.	
0010	08	060	US 67	

FILE: T:\engdata\Traffic\DGN\192515 Jamie\JOBS\LIGHTING PROJECTS\LIGHTING Project May 2024\Intersections\FM 1845 at FM 1844\FM 1845 at FM 1844.dgn
 DATE: 1/25/2024 9:31:15 AM

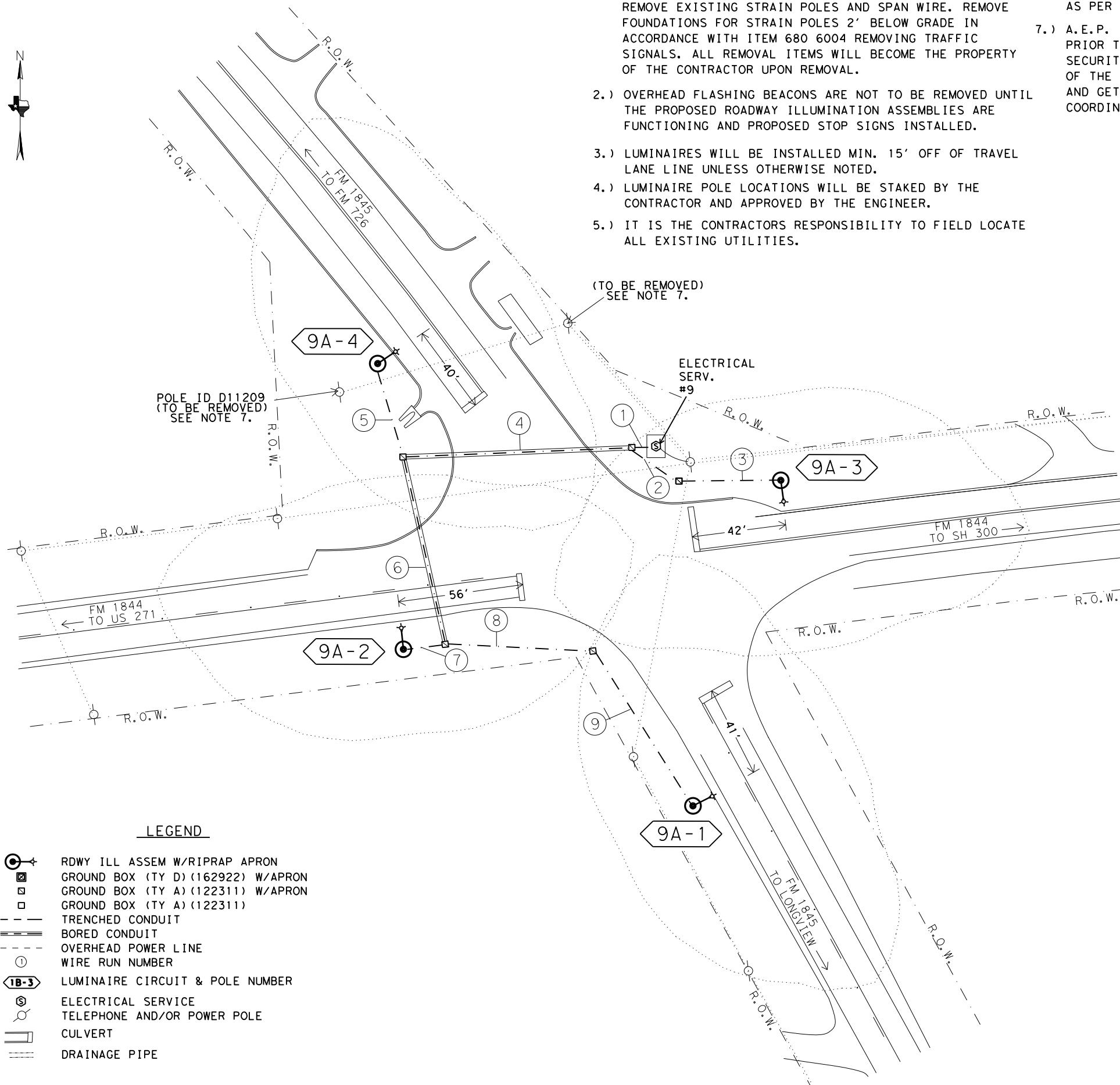

NOTE:

- 1.) INSTALL PROPOSED ROADWAY ILLUMINATION ASSEMBLIES. REMOVE EXISTING STRAIN POLES AND SPAN WIRE. REMOVE FOUNDATIONS FOR STRAIN POLES 2' BELOW GRADE IN ACCORDANCE WITH ITEM 680 6004 REMOVING TRAFFIC SIGNALS. ALL REMOVAL ITEMS WILL BECOME THE PROPERTY OF THE CONTRACTOR UPON REMOVAL.
- 2.) OVERHEAD FLASHING BEACONS ARE NOT TO BE REMOVED UNTIL THE PROPOSED ROADWAY ILLUMINATION ASSEMBLIES ARE FUNCTIONING AND PROPOSED STOP SIGNS INSTALLED.
- 3.) LUMINAIRES WILL BE INSTALLED MIN. 15' OFF OF TRAVEL LANE LINE UNLESS OTHERWISE NOTED.
- 4.) LUMINAIRE POLE LOCATIONS WILL BE STAKED BY THE CONTRACTOR AND APPROVED BY THE ENGINEER.
- 5.) IT IS THE CONTRACTORS RESPONSIBILITY TO FIELD LOCATE ALL EXISTING UTILITIES.
- 6.) LUMINAIRES WILL BE PLACED PERPENDICULAR TO THE ROADWAY AS PER DEPARTMENT REQUIREMENTS.
- 7.) A.E.P. TO REMOVE POLE ID D11209 THAT HAS A SECURITY LIGHT PRIOR TO STANDING POLE 1A-4. WHEN LIGHTING IS INSTALLED SECURITY LIGHT NO LONGER NEEDED HERE. THIS WILL GET RID OF THE LATERAL COMING ACROSS FM 1845 ON THE NORTH END AND GET RID OF THE POWER POLE ACROSS FROM IT. TXDOT TO COORDINATE WITH AEP ON THIS.

LEGEND

- RDWY ILL ASSEM W/RIPRAP APRON
- GROUND BOX (TY D) (162922) W/APRON
- GROUND BOX (TY A) (122311) W/APRON
- GROUND BOX (TY A) (122311)
- TRENCHED CONDUIT
- BORED CONDUIT
- OVERHEAD POWER LINE
- WIRE RUN NUMBER
- LUMINAIRE CIRCUIT & POLE NUMBER
- ELECTRICAL SERVICE
- TELEPHONE AND/OR POWER POLE
- CULVERT
- DRAINAGE PIPE

40' POLES WITH (250W EQ) LED HEADS ALL APPROACHES.

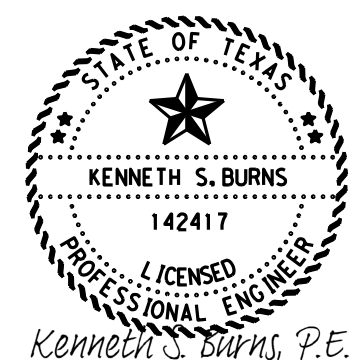

Kenneth S. Burns, P.E.
 1/30/2024

**PROPOSED ILLUMINATION LAYOUT
 FM 1845 AT FM 1844**

© 2024 Texas Department of Transportation
 SHEET 1 OF 2

FHWA TEXAS DIVISION		CONSTRUCTION PROJECT NO.		SHEET NO.	
				69	
STATE	DISTRICT	COUNTY			
TEXAS	ATL	MORRIS			
CONTROL	SECTION	JOB	HIGHWAY NO.		
0010	08	060	US 67		

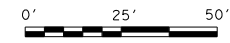

FILE: T:\engdata\Traffic\DGN\192515 Jamie\JOBS\LIGHTING PROJECTS\Lighting Project May 2024\Intersections\FM 1845 at FM 1844\FM 1845 at FM 1844.dgn
 DATE: 1/25/2024 9:33:37 AM

CONDUIT AND CONDUCTOR RUNS FOR ILLUMINATION								
RUN NO.	CONDUIT 2" PVC		TYP D GROUND BOX APRON NONE	TYP A GROUND BOX APRON NONE	CONDUCTORS			
	BORED (LF)	TRENCHED (LF)			#6 INSULATED		#6 BARE	
					NO. OF CONDUCTORS	LF	NO. OF CONDUCTORS	LF
1		11		1	2	42	1	21
2		26		1	2	62	1	31
3		46			2	102	1	51
4	103			1	2	216	1	108
5		44			2	98	1	49
6	86			1	2	182	1	91
7		19			2	48	1	24
8		66			2	142	1	71
9		83			2	176	1	88
TOTALS	189	295		4		1068		534

* CALCULATIONS FOR WIRE TOTALS:
 -5' OF SLACK FOR GROUND BOXES. (PER CONDUCTOR)
 -5' OF SLACK FOR WIRE IN THE SERVICE. (PER CONDUCTOR)
 -5' OF SLACK FOR WIRE IN THE BASE OF ILLUMINATION POLES. (PER CONDUCTOR)

- 1.) INSTALL PROPOSED ROADWAY ILLUMINATION ASSEMBLIES. REMOVE EXISTING STRAIN POLES AND SPAN WIRE. REMOVE FOUNDATIONS FOR STRAIN POLES 2' BELOW GRADE IN ACCORDANCE WITH ITEM 680 6004 REMOVING TRAFFIC SIGNALS. ALL REMOVAL ITEMS WILL BECOME THE PROPERTY OF THE CONTRACTOR UPON REMOVAL.
- 2.) OVERHEAD FLASHING BEACONS ARE NOT TO BE REMOVED UNTIL THE PROPOSED ROADWAY ILLUMINATION ASSEMBLIES ARE FUNCTIONING AND PROPOSED STOP SIGNS INSTALLED.
- 3.) LUMINAIRES WILL BE INSTALLED MIN. 15' OFF OF TRAVEL LANE LINE UNLESS OTHERWISE NOTED.
- 4.) LUMINAIRE POLE LOCATIONS WILL BE STAKED BY THE CONTRACTOR AND APPROVED BY THE ENGINEER.
- 5.) IT IS THE CONTRACTORS RESPONSIBILITY TO FIELD LOCATE ALL EXISTING UTILITIES.
- 6.) LUMINAIRES WILL BE PLACED PERPENDICULAR TO THE ROADWAY AS PER DEPARTMENT REQUIREMENTS.

ROADWAY ILLUMINATION ASSEMBLY SUMMARY			
POLE	TYPE	FND. (LF)	REMARKS
9A-1	(TY SA)40T-10(250W EQ)LED	10	12' OFF TRAVEL LANE
9A-2	(TY SA)40T-10(250W EQ)LED	10	15' OFF TRAVEL LANE
9A-3	(TY SA)40T-10(250W EQ)LED	10	14' OFF TRAVEL LANE
9A-4	(TY SA)40T-10(250W EQ)LED	10	7' OFF BACK OF CURB

SUMMARY OF QUANTITIES-ILLUMINATION				
ITEM	DESC CODE	DESCRIPTION	UNIT	TOTAL
0416	6029	DRILL SHAFT (RDWY ILL POLE) (30 IN)	LF	40
0432	6006	RIPRAP (CONC) (CL B)	CY	2
0610	6216	IN RD IL (TY SA)40T-10(250W EQ)LED	EA	4
0618	6023	COND (PVC) (SCHD 40) (2")	LF	295
0618	6024	COND (PVC) (SCHD 40) (2") (BORE)	LF	189
0620	6009	ELEC CONDR (NO. 6) BARE	LF	534
0620	6010	ELEC CONDR (NO. 6) INSULATED	LF	1068
0624	6002	GROUND BOX TY A (122311)W/APRON	EA	4
0628	6004	ELC SRV TY A 120/240 060 (NS) AL (E) SP (O)	EA	1
0680	6004	REMOVING TRAFFIC SIGNALS	EA	1
6185	6002	TMA (STATIONARY)	DAY	8

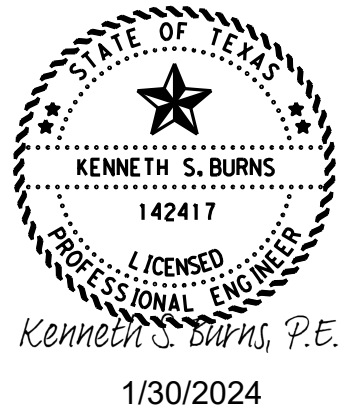

PROPOSED ILLUMINATION LAYOUT FM 1845 AT FM 1844

© 2024 Texas Department of Transportation
 SHEET 2 OF 2

FHWA TEXAS DIVISION		CONSTRUCTION PROJECT NO.		SHEET NO.
				70
STATE	DISTRICT	COUNTY		
TEXAS	ATL	MORRIS		
CONTROL	SECTION	JOB	HIGHWAY NO.	
0010	08	060	US 67	

NOT TO SCALE

FILE: T:\engdata\Traffic\Lighting\Projects\Lighting Project May 2024\Intersections\FM 1845 at FM 1844\FM 1845 at FM 1844.dgn
 DATE: 1/25/2024 9:34:22 AM

LEGEND

- [E] EXISTING SIGN TO BE REMOVED
- P PROPOSED SIGN
- (A) PREFAB PAV MRK TY C (W) (24") (SLD)
- (B) PREFAB PAV MRK TY C (W) (ARROW)
- (C) PREFAB PAV MRK TY C (W) (WORD)
- (D) PREFAB PAV MRK TY C (W) (36") (YLD TRI)
- (E) PREFORMED IN-LANE (TRANS) RUMBLE STRIP

NOTE:

- 1.) REMOVE EXISTING STOP SIGNS. INSTALL PROPOSED STOP SIGN WITH ALL WAY PLAQUES AS SHOWN. THE STOP SIGNS SHOWN WITH THE LED RING WILL NEED TO HAVE THE POST 12" TALLER THAN THE TOP OF THE SIGN FOR BEACON INSTALLATION. STATE FORCES WILL COME IN AND INSTALL THE RING ASSEMBLIES FOR THIS AFTER THE CONTRACTOR HAS MOUNTED THE SIGNS.
- 2.) ENSURE 7' MIN CLEARANCE AND 7.5' MAX VERTICAL CLEARANCE TO BOTTOM OF SUPPLEMENTAL PLAQUE (CROSS TRAFFIC DOES NOT STOP). REFER TO SIGN STANDARD SMD (GEN)-08 FOR SIGN PLACEMENT DETAILS.
- 3.) REMOVE EXISTING STOP AHEAD SIGNS AND POSTS ON THE APPROACHES AS SHOWN. INSTALL PROPOSED STOP AHEAD SIGNS WITHIN 5' OF EXISTING STOP AHEAD SIGNS ON ALL APPROACHES TO KEEP IN LINE WITH EXISTING PAVEMENT MARKINGS.
- 4.) INSTALLED SIGN ASSEMBLIES WILL REQUIRE OMNI-DIRECTIONAL POST WRAP. THIS WRAP WILL BE SUBSIDIARY TO ITEM 644. REFERENCE ITEM 644 SMALL ROADSIDE SIGN ASSEMBLIES IN THE GENERAL NOTES FOR MORE INFORMATION.
- 5.) RESTRIPE EXISTING STOP BARS, WORDS, AND PREFORMED IN-LANE (TRANS) RUMBLE STRIPS IN PLACE.

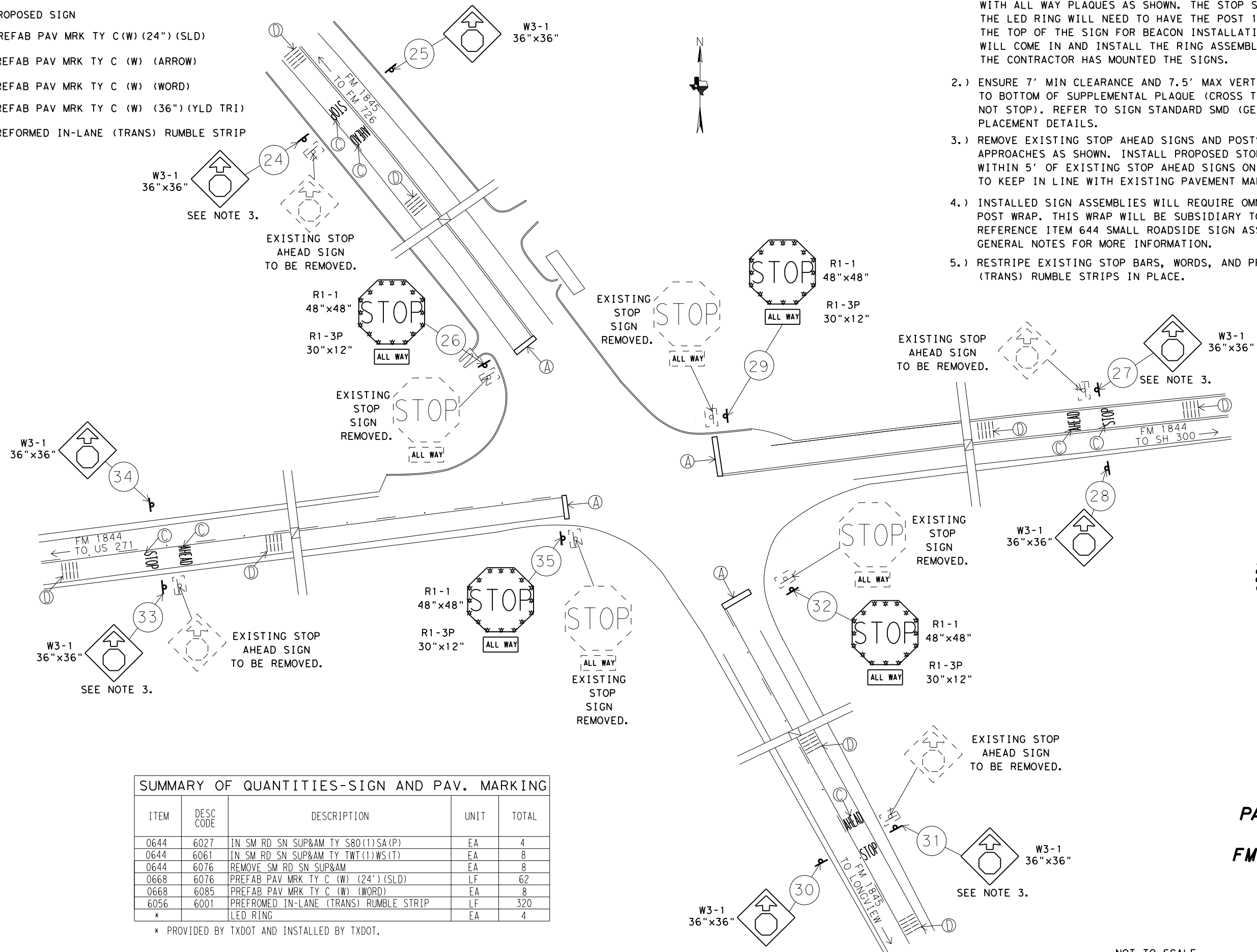

SUMMARY OF QUANTITIES-SIGN AND PAV. MARKING				
ITEM	DESC CODE	DESCRIPTION	UNIT	TOTAL
0644	6027	IN SM RD SN SUP&AM TY S80(1)SA(P)	EA	4
0644	6061	IN SM RD SN SUP&AM TY TWT(1)WS(T)	EA	8
0644	6076	REMOVE SM RD SN SUP&AM	EA	8
0668	6076	PREFAB PAV MRK TY C (W) (24') (SLD)	LF	62
0668	6085	PREFAB PAV MRK TY C (W) (WORD)	EA	8
6056	6001	PREFORMED IN-LANE (TRANS) RUMBLE STRIP	LF	320
*		LED RING	EA	4

* PROVIDED BY TXDOT AND INSTALLED BY TXDOT.

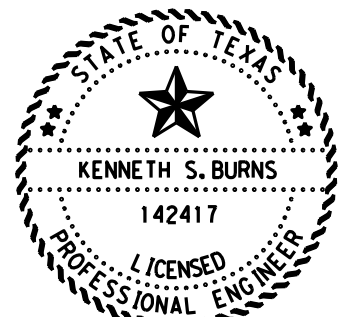

Kenneth S. Burns, P.E.

1/30/2024

**PROPOSED
SIGN AND
PAVEMENT MARKING
LAYOUT
FM 1845 AT FM 1844**



FHWA TEXAS DIVISION		CONSTRUCTION PROJECT NO.		SHEET NO.
				71
STATE	DISTRICT	COUNTY		
TEXAS	ATL	MORRIS		
CONTROL	SECTION	JOB	HIGHWAY NO.	
0010	08	060	US 67	

NOT TO SCALE

DATE: 1/11/2024 3:08:08 PM
 FILE: T:\engdat\Traffic\Lighting\PROJECTS\Lighting\01-01-15\01-01-15.dgn
 DISCLAIMER: The use of this standard is governed by the "Texas Engineering Practice Act". No warranty of any kind is made by TxDOT for any purpose whatsoever. TxDOT assumes no responsibility for the conversion of any information into a digital format or for any errors or omissions that may result from its use.

REQUIREMENTS FOR RED BACKGROUND REGULATORY SIGNS

(STOP, YIELD, DO NOT ENTER AND WRONG WAY SIGNS)

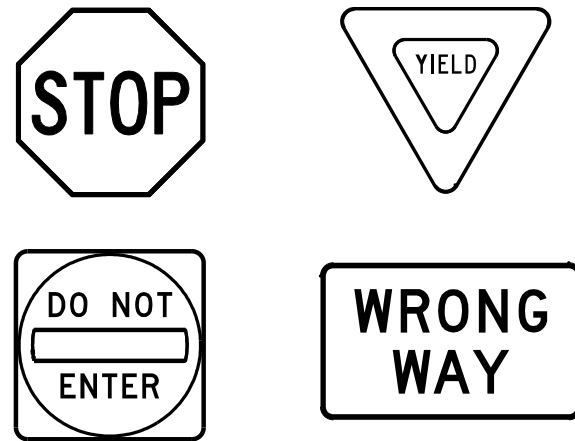

REQUIREMENTS FOR FOUR SPECIFIC SIGNS ONLY

SHEETING REQUIREMENTS		
USAGE	COLOR	SIGN FACE MATERIAL
BACKGROUND	RED	TYPE B OR C SHEETING
BACKGROUND	WHITE	TYPE B OR C SHEETING
LEGEND & BORDERS	WHITE	TYPE B OR C SHEETING
LEGEND	RED	TYPE B OR C SHEETING

REQUIREMENTS FOR WHITE BACKGROUND REGULATORY SIGNS

(EXCLUDING STOP, YIELD, DO NOT ENTER AND WRONG WAY SIGNS)



TYPICAL EXAMPLES

SHEETING REQUIREMENTS		
USAGE	COLOR	SIGN FACE MATERIAL
BACKGROUND	WHITE	TYPE A SHEETING
BACKGROUND	ALL OTHERS	TYPE B OR C SHEETING
LEGEND, BORDERS AND SYMBOLS	BLACK	ACRYLIC NON-REFLECTIVE FILM
LEGEND, BORDERS AND SYMBOLS	ALL OTHER	TYPE B OR C SHEETING

REQUIREMENTS FOR WARNING SIGNS

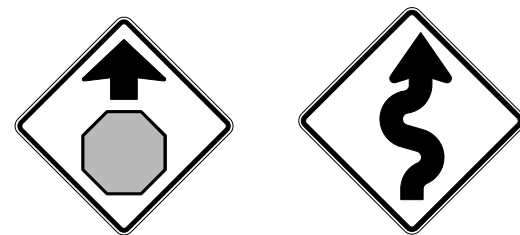

TYPICAL EXAMPLES

SHEETING REQUIREMENTS		
USAGE	COLOR	SIGN FACE MATERIAL
BACKGROUND	FLOURESCENT YELLOW	TYPE B _{FL} OR C _{FL} SHEETING
LEGEND & BORDERS	BLACK	ACRYLIC NON-REFLECTIVE FILM
LEGEND & SYMBOLS	ALL OTHER	TYPE B OR C SHEETING

REQUIREMENTS FOR SCHOOL SIGNS



TYPICAL EXAMPLES

SHEETING REQUIREMENTS		
USAGE	COLOR	SIGN FACE MATERIAL
BACKGROUND	WHITE	TYPE A SHEETING
BACKGROUND	FLOURESCENT YELLOW GREEN	TYPE B _{FL} OR C _{FL} SHEETING
LEGEND, BORDERS AND SYMBOLS	BLACK	ACRYLIC NON-REFLECTIVE FILM
SYMBOLS	RED	TYPE B OR C SHEETING

GENERAL NOTES

- Signs to be furnished shall be as detailed elsewhere in the plans and/or as shown on sign tabulation sheet. Standard sign designs and arrow dimensions can be found in the "Standard Highway Sign Designs for Texas" (SHSD).
- Sign legend shall use the Federal Highway Administration (FHWA) Standard Highway Alphabets (B, C, D, E, Emod or F).
- Lateral spacing between letters and numerals shall conform with the SHSD, and any approved changes thereto. Lateral spacing of legend shall provide a balanced appearance when spacing is not shown.
- Black legend and borders shall be applied by screening process or cut-out acrylic non-reflective black film to background sheeting, or combination thereof.
- White legend and borders shall be applied by screening process with transparent colored ink, transparent colored overlay film to white background sheeting or cut-out white sheeting to colored background sheeting, or combination thereof.
- Colored legend shall be applied by screening process with transparent colored ink, transparent colored overlay film or colored sheeting to background sheeting, or combination thereof.
- Sign substrate shall be any material that meets the Departmental Material Specification requirements of DMS-7110 or approved alternative.
- Mounting details for roadside mounted signs are shown in the "SMD series" Standard Plan Sheets.

ALUMINUM SIGN BLANKS THICKNESS

Square Feet	Minimum Thickness
Less than 7.5	0.080
7.5 to 15	0.100
Greater than 15	0.125

DEPARTMENTAL MATERIAL SPECIFICATIONS

ALUMINUM SIGN BLANKS	DMS-7110
SIGN FACE MATERIALS	DMS-8300

The Standard Highway Sign Designs for Texas (SHSD) can be found at the following website.

<http://www.txdot.gov/>



TYPICAL SIGN REQUIREMENTS

TSR(4) - 13

FILE:	tsr4-13.dgn	DN:	TxDOT	CK:	TxDOT	DW:	TxDOT	CK:	TxDOT
© TxDOT	October 2003	CONT	SECT	JOB	HIGHWAY				
REVISIONS		0010	08	060	US 67				
12-03	7-13	DIST	COUNTY	SHEET NO.					
9-08		ATL	MORRIS	73					

DISCLAIMER: The use of this standard is governed by the "Texas Engineering Practice Act". No warranty of any kind is made by TxDOT for any purpose whatsoever. TxDOT assumes no responsibility for the conversion of units or for any errors or omissions in this standard.

DATE: 1/11/2024 3:08:36 PM
 FILE: T:\Engdara\Traffic\Lighting\PROJECTS\Lighting\192515_Jamie\JOBS\LIGHTING PROJECTS\Lighting\192515_Jamie\192515.dgn

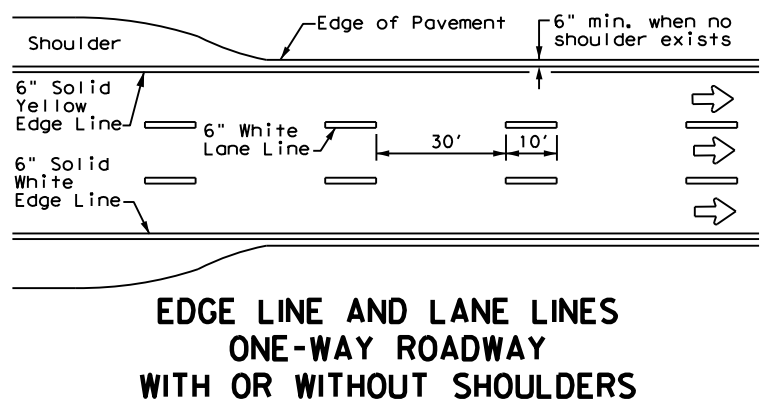

**EDGE LINE AND LANE LINES
ONE-WAY ROADWAY
WITH OR WITHOUT SHOULDERS**

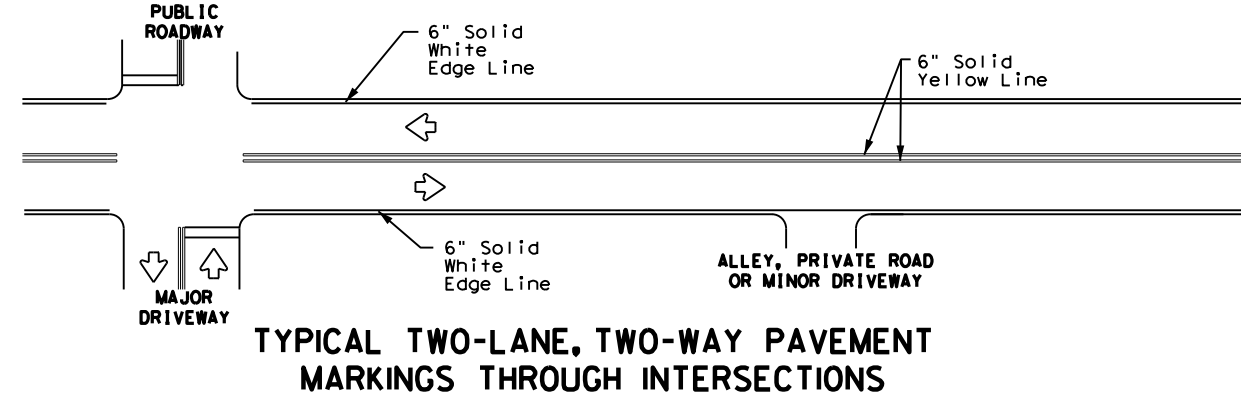

**TYPICAL TWO-LANE, TWO-WAY PAVEMENT
MARKINGS THROUGH INTERSECTIONS**

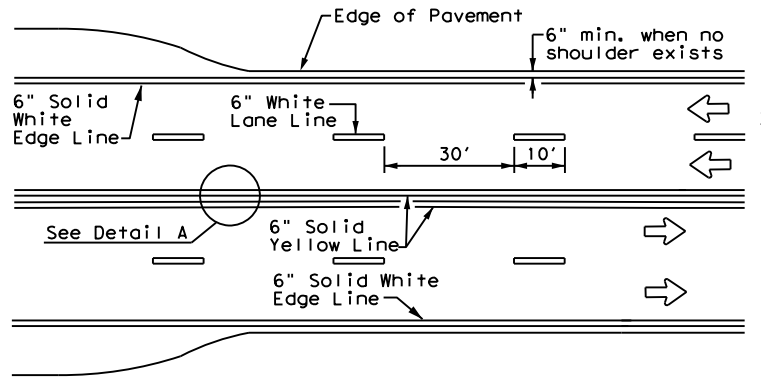

**CENTERLINE AND LANE LINES
FOUR LANE TWO-WAY ROADWAY
WITH OR WITHOUT SHOULDERS**

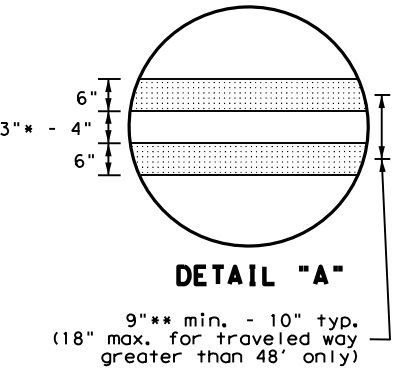

DETAIL "A"
 9" min. - 10" typ.
 (18" max. for traveled way greater than 48' only)

* 2" minimum for restripe projects when approved by the Engineer.
 ** 8" minimum for restripe projects when approved by the Engineer.

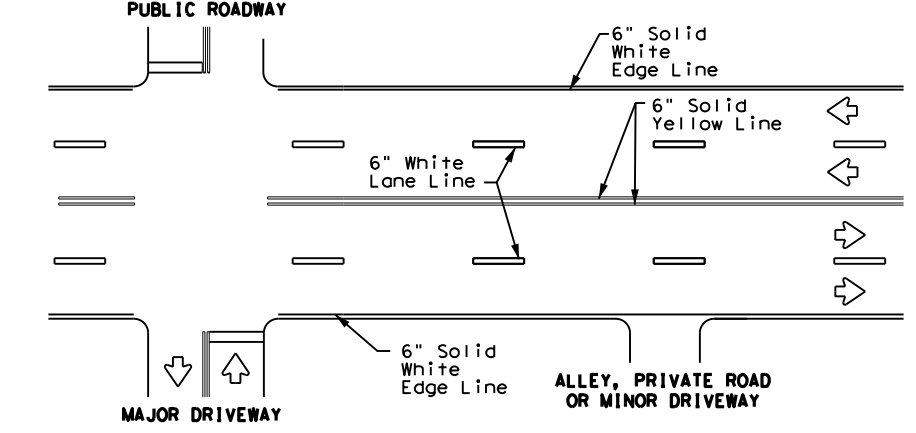

**TYPICAL MULTI-LANE, TWO-WAY PAVEMENT
MARKINGS THROUGH INTERSECTIONS**

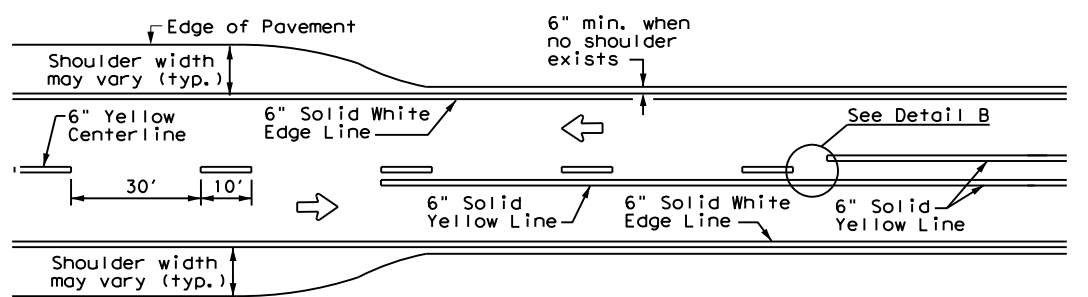

**TWO LANE TWO-WAY ROADWAY
WITH OR WITHOUT SHOULDERS**

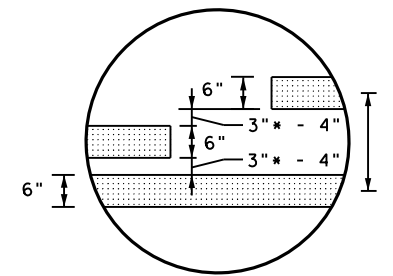

DETAIL "B"
 18" min. - 20" max.
 (16" minimum for restripe projects when approved by the Engineer.)

* 2" minimum for restripe projects when approved by the Engineer.

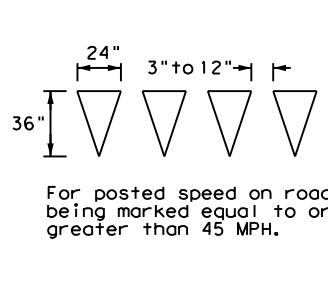

YIELD LINES

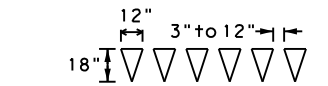

For posted speed on road being marked equal to or less than 40 MPH.

- GENERAL NOTES**
- Edge line striping shall be as shown in the plans or as directed by the Engineer. The edge line should not be placed less than 6 inches from the edge of pavement. This distance may vary due to pavement raveling or other conditions. Edge lines are not required in curb and gutter sections of roadways.
 - The traveled way includes only that portion of the roadway used for vehicular travel. It does not include the parking lanes, sidewalks, berms and shoulders. The traveled ways shall be measured from the center of edge line to the center of edge line of a two lane roadway.

MATERIAL SPECIFICATIONS	
PAVEMENT MARKERS (REFLECTORIZED)	DMS-4200
EPOXY AND ADHESIVES	DMS-6100
BITUMINOUS ADHESIVE FOR PAVEMENT MARKERS	DMS-6130
TRAFFIC PAINT	DMS-8200
HOT APPLIED THERMOPLASTIC	DMS-8220
PERMANENT PREFABRICATED PAVEMENT MARKINGS	DMS-8240

All pavement marking materials shall meet the required Departmental Material Specifications as specified by the plans.

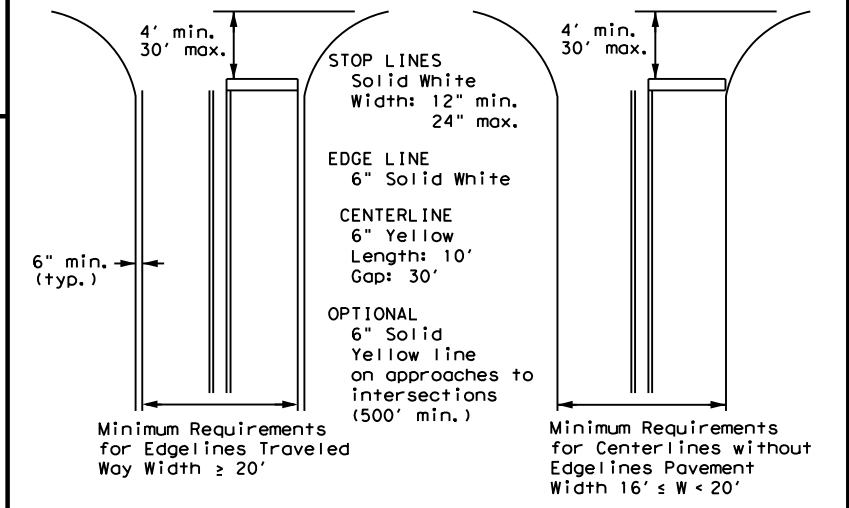

NOTE: Traveled way is exclusive of shoulder widths. Refer to General Note 2 for additional details.

**GUIDE FOR PLACEMENT OF STOP LINES,
EDGE LINE & CENTERLINE**
 Based on Traveled Way and Pavement Widths for Undivided Roadways

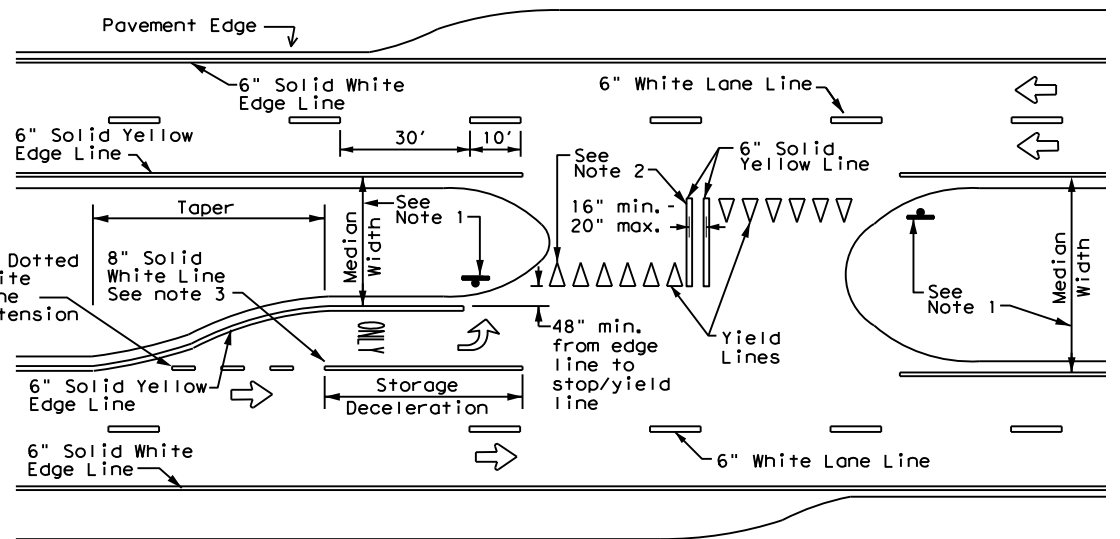

FOUR LANE DIVIDED ROADWAY CROSSOVERS

NOTES

- Where divided highways are separated by median widths at the median opening itself of 30 feet or more, median openings shall be signed as two separate intersections. Each median opening has two width measurements, with one measurement for each approach. The narrow median width will be the controlling width to determine if signs are required. Yield signs are the typical intersection control. Stop signs and stop bars are optional as determined by the Engineer.
- Install median striping (double yellow centerlines and stop lines/yield lines) when a 50' or greater median centerline can be placed. Stop lines shall only be used with stop signs. Yield lines shall only be used with yield signs.
- Length of turn bays, including taper, deceleration, and storage lengths shall be as shown on the plans or as directed by the Engineer.

Texas Department of Transportation
 Traffic Safety Division Standard

**TYPICAL STANDARD
PAVEMENT MARKINGS**

PM(1) - 22

FILE: pm1-22.dgn	DN:	CK:	DW:	CK:
© TxDOT December 2022	CONT	SECT	JOB	HIGHWAY
REVISIONS	0010	08	060	US 67
11-78 8-00 6-20	DIST	COUNTY	SHEET NO.	
8-95 3-03 12-22	ATL	MORRIS	74	
5-00 2-12				

22A

DISCLAIMER: The use of this standard is governed by the "Texas Engineering Practice Act". No warranty of any kind is made by TxDOT for any purpose whatsoever. TxDOT assumes no responsibility for the conversion of units or for any errors or omissions in this standard or for any damages resulting from its use.

DATE: 1/11/2024 3:09:14 PM
 FILE: I:\engdata\Traffic\Lighting\PROJECTS\Lighting\0222\0222.dgn

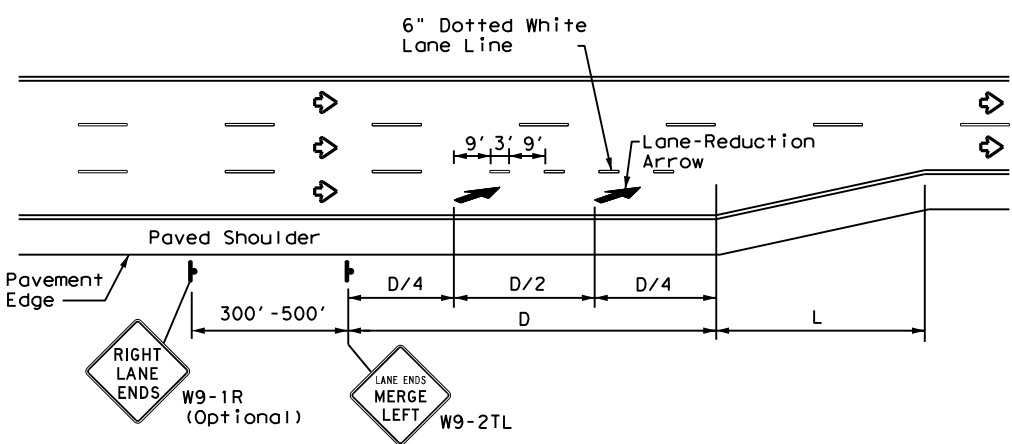

LANE REDUCTION

NOTES

- Lane reduction pavement markings are used where the number of through lanes is reduced because of narrowing of the roadway or because of a section of on-street parking in what would otherwise be a through lane. For Texas Super 2 Passing Lanes, see TS2(PL) standard sheets.
- On divided highways, an additional RIGHT LANE ENDS (W9-1R) sign may be installed in the median aligned with the W9-1R sign on the right side of the highway.
- Lane reduction arrows are required for speeds of 45 mph or greater. An optional third lane reduction arrow may be added based on engineering judgement. If used, the optional third lane reduction arrow should be centered between the first and last lane reduction arrows.
- For lane reductions on Freeways and Expressways, signing shall conform to the TxDOT Freeway Signing Handbook.

ADVANCED WARNING SIGN DISTANCE (D)		
Posted Speed	D (ft)	L (ft)
30 MPH	460	$L = \frac{WS^2}{60}$
35 MPH	565	
40 MPH	670	
45 MPH	775	L=WS
50 MPH	885	
55 MPH	990	
60 MPH	1,100	
65 MPH	1,200	
70 MPH	1,250	
75 MPH	1,350	

GENERAL NOTES

- Lane use word and arrow markings shall be used where through lanes approaching an intersection become mandatory turn lanes. Lane use word and arrow markings should be used in auxiliary lanes of substantial length. Lane use arrow markings or word and arrow markings may be used in other lanes and turn bays for emphasis. Details for words and arrows are as shown in the Standard Highway Sign Designs for Texas.
- When lane-use words and arrow markings are used, two sets of arrows should be used if the length of the bay is greater than 180 feet. When a single lane use arrow or word and arrow marking is used for a short turn lane, it should be located at or near the upstream end of the full-width turn lane.
- Use raised pavement marker Type I-C with undivided highways, flush medians and two way left turn lanes. Use raised pavement marker Type II-C-R with divided highways and raised medians.
- Length of turn bays, including taper, deceleration, and storage lengths shall be as shown on the plans or as directed by the Engineer. See Chapter 3 of the Roadway Design Manual for additional information on turning lanes or storage lengths.

MATERIAL SPECIFICATIONS	
PAVEMENT MARKERS (REFLECTORIZED)	DMS-4200
EPOXY AND ADHESIVES	DMS-6100
BITUMINOUS ADHESIVE FOR PAVEMENT MARKERS	DMS-6130
TRAFFIC PAINT	DMS-8200
HOT APPLIED THERMOPLASTIC	DMS-8220
PERMANENT PREFABRICATED PAVEMENT MARKINGS	DMS-8240

All pavement marking materials shall meet the required Departmental Material Specifications as specified by the plans.

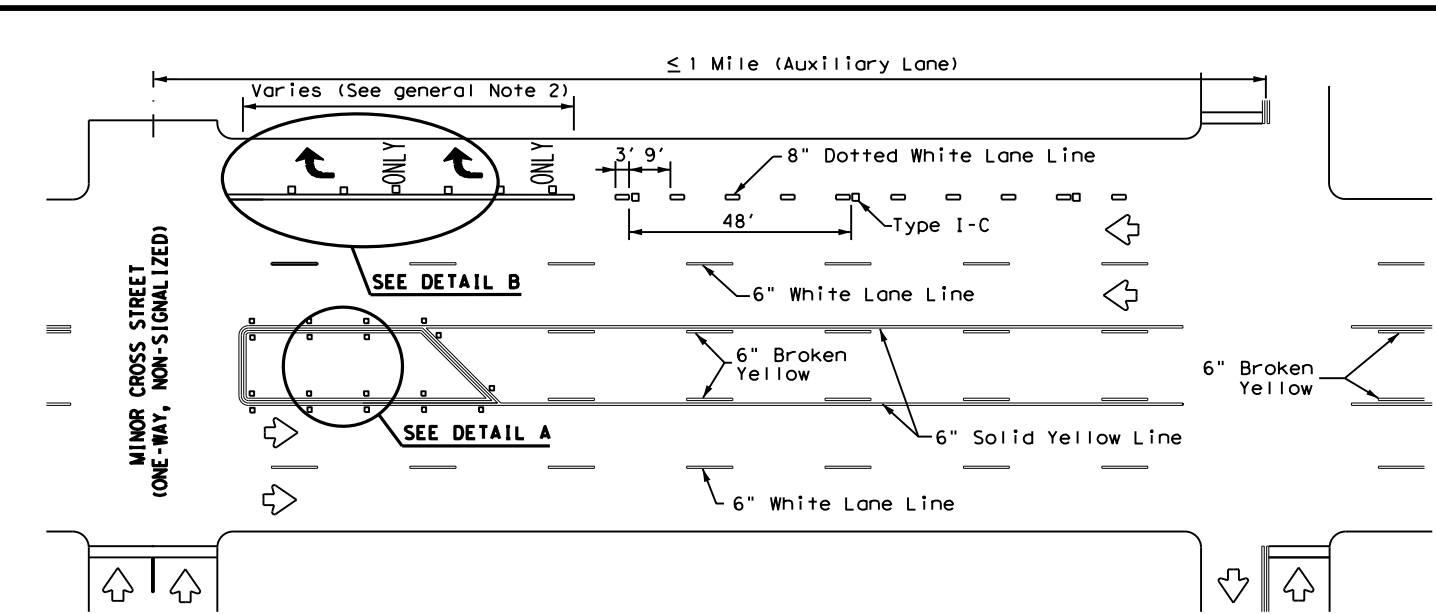

TYPICAL TWLTL AT ONE-WAY STREET AND RIGHT TURN AUXILIARY LANE

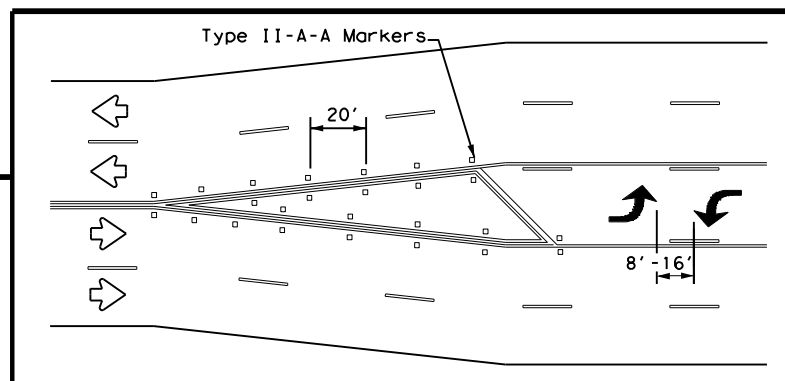

A two-way left-turn (TWLTL) lane-use arrow pavement marking should be used at or just downstream from the beginning of a two-way left-turn lane within a corridor. Repeating the marking after each intersection or dedicated turn bay is not required unless stated elsewhere in the plans.

TYPICAL TRANSITION FOR TWLTL AND DIVIDED HIGHWAY

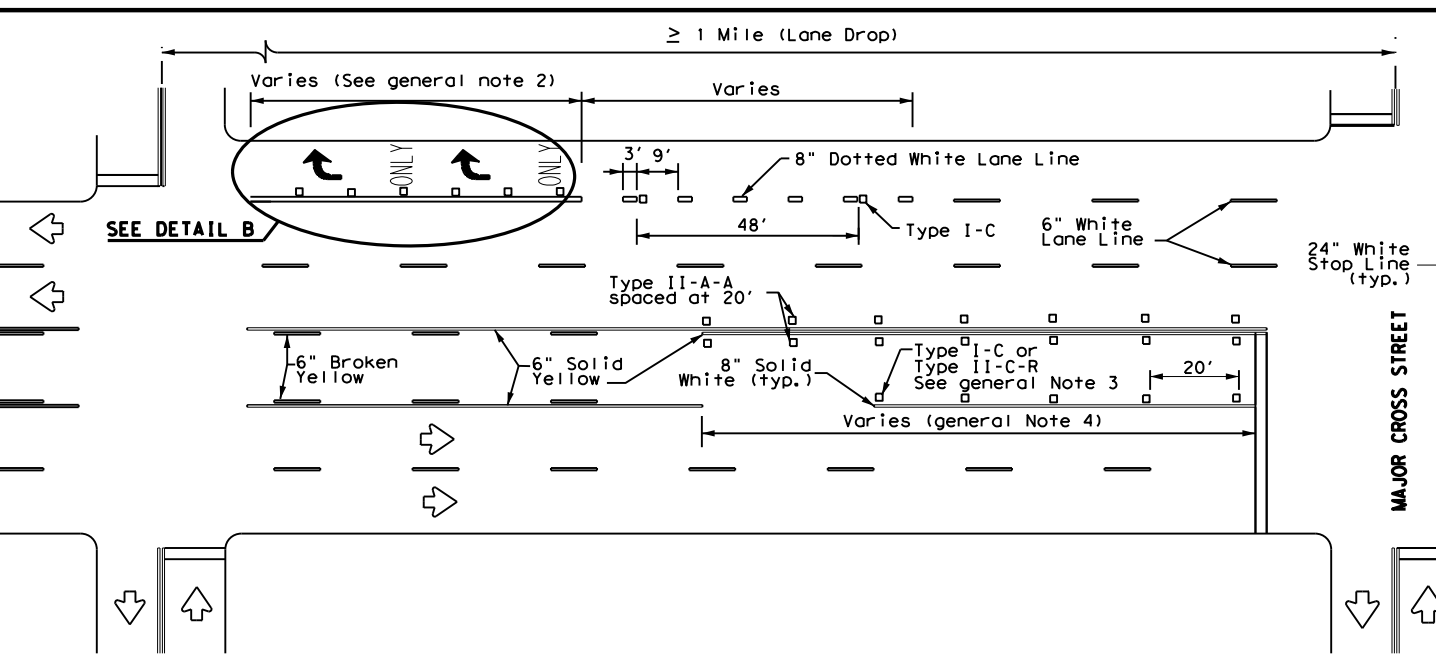

TYPICAL TWLTL AT TWO-WAY CROSS STREET AND RIGHT TURN LANE DROP

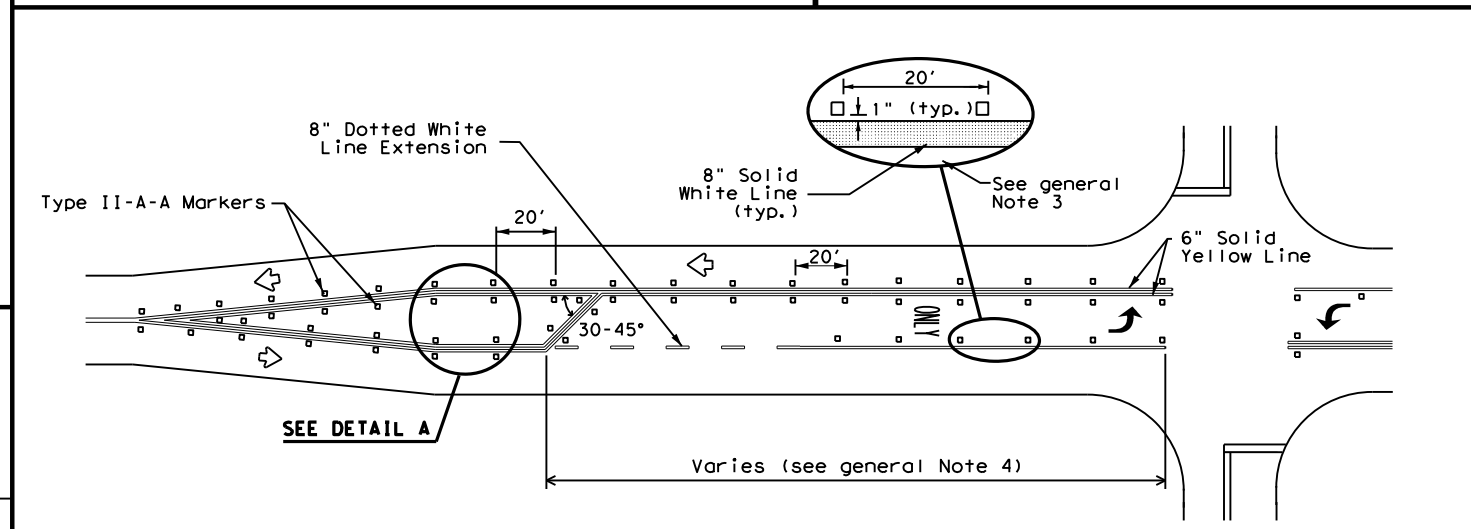

TYPICAL TWO-LANE ROADWAY INTERSECTION WITH LEFT TURN BAYS

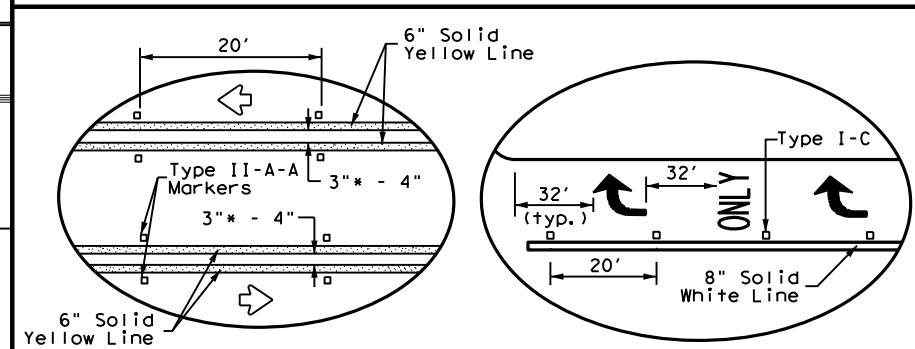

DETAIL A

DETAIL B

* 2" minimum allowed for restripe projects when approved by the Engineer.

Texas Department of Transportation
 Traffic Safety Division Standard

TWO-WAY LEFT TURN LANES, RURAL LEFT TURN BAYS, AND LANE REDUCTION PAVEMENT MARKINGS PM(3) - 22

FILE: pm3-22.dgn	DN:	CK:	DW:	CK:
© TxDOT December 2022	CONT	SECT	JOB	HIGHWAY
REVISIONS	0010	08	060	US 67
4-98 3-03 6-20	DIST	COUNTY	SHEET NO.	
5-00 2-10 12-22	ATL	MORRIS	75	
8-00 2-12				

DISCLAIMER: The use of this standard is governed by the "Texas Engineering Practice Act". No warranty of any kind is made by TxDOT for any purpose whatsoever. TxDOT assumes no responsibility for the conversion of this standard to other formats or for incorrect results or damages resulting from its use.

DATE: 1/11/2024 3:10:04 PM
 FILE: I:\Engdata\Traffic\Lighting\PROJECTS\Lighting\Project May 2024\standards\smgden.dgn

SIGN SUPPORT DESCRIPTIVE CODES

(Descriptive Codes correspond to project estimate and quantities sheets)

SM RD SGN ASSM TY XXXXX(X)XX(X-XXXX)

Post Type

FRP = Fiberglass Reinforced Plastic Pipe (see SMD(FRP))
 TWT = Thin-Walled Tubing (see SMD(TWT))
 10BWG = 10 BWG Tubing (see SMD(SLIP-1) to (SLIP-3))
 S80 = Schedule 80 Pipe (see SMD(SLIP-1) to (SLIP-3))

Number of Posts (1 or 2)

Anchor Type

UA = Universal Anchor - Concreted (see SMD(FRP) and (TWT))
 UB = Universal Anchor - Bolted down (see SMD(FRP) and (TWT))
 WS = Wedge Anchor Steel - (see SMD(TWT))
 WP = Wedge Anchor Plastic (see SMD(TWT))
 SA = Slipbase - Concreted (see SMD(SLIP-1) to (SLIP-3))
 SB = Slipbase - Bolted Down (see SMD(SLIP-1) to (SLIP-3))

Sign Mounting Designation

P = Prefab. "Plain" (see SMD(SLIP-1) to (SLIP-3), (TWT), (FRP))
 T = Prefab. "T" (see SMD(SLIP-1) to (SLIP-3), (TWT))
 U = Prefab. "U" (see SMD(SLIP-1) to (SLIP-3))
 IF REQUIRED
 1EXT or 2EXT = Number of Extensions (see SMD(SLIP-1) to (SLIP-3), (TWT))
 BM = Extruded Wind Beam (see SMD(SLIP-1) to (SLIP-3))
 WC = 1.12 #/ft Wing Channel (see SMD(SLIP-1) to (SLIP-3))
 EXAL = Extruded Aluminum Sign Panels (see SMD(SLIP-3))

REQUIRED CLEARANCE FOR BREAKAWAY SUPPORT

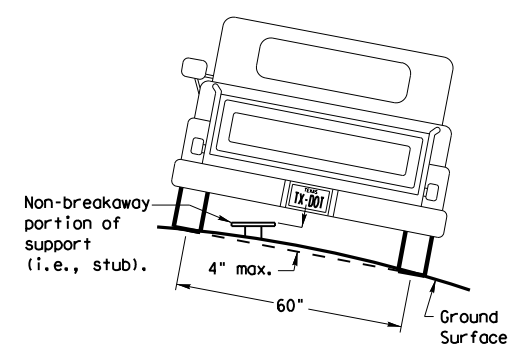

To avoid vehicle undercarriage snagging, any substantial remains of a breakaway support, when it is broken away, should not project more than 4 inches above a 60-inch chord (i.e., typical space between wheel paths).

SIGN LOCATION

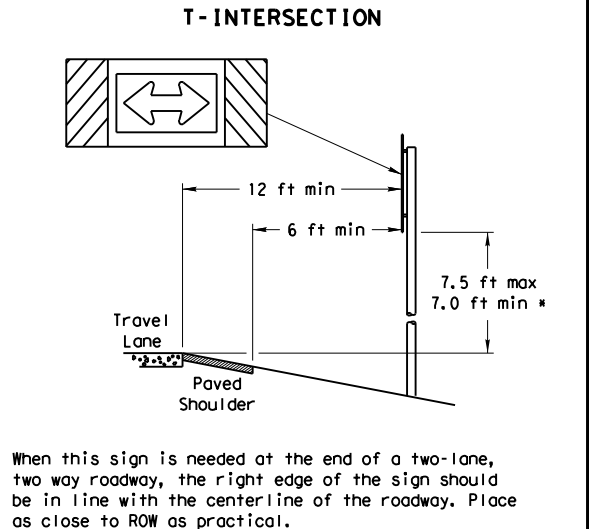
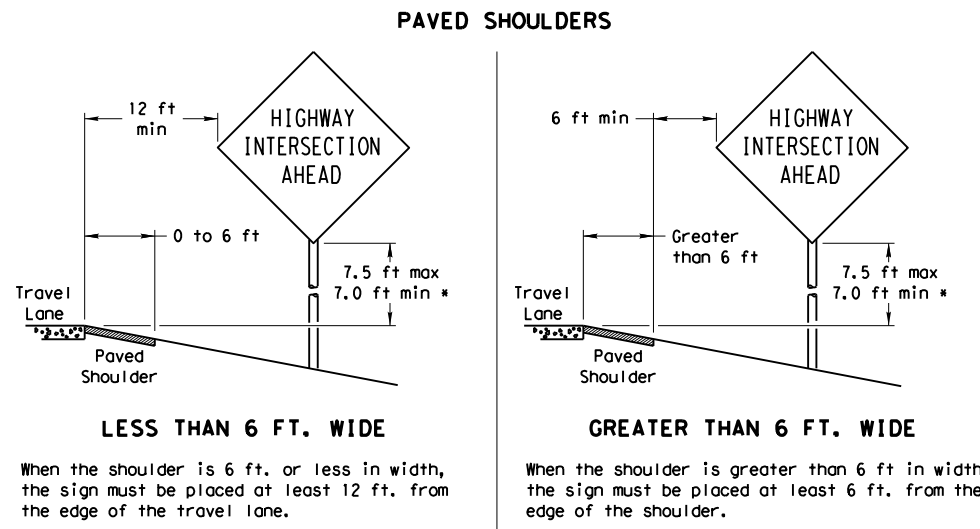

No more than 2 sign posts should be located within a 7 ft. circle.

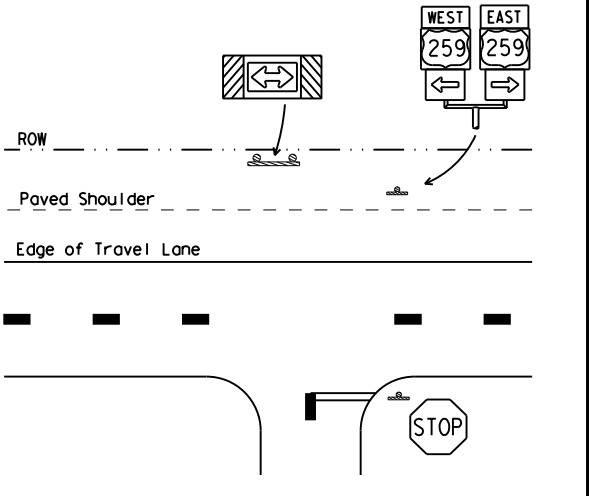
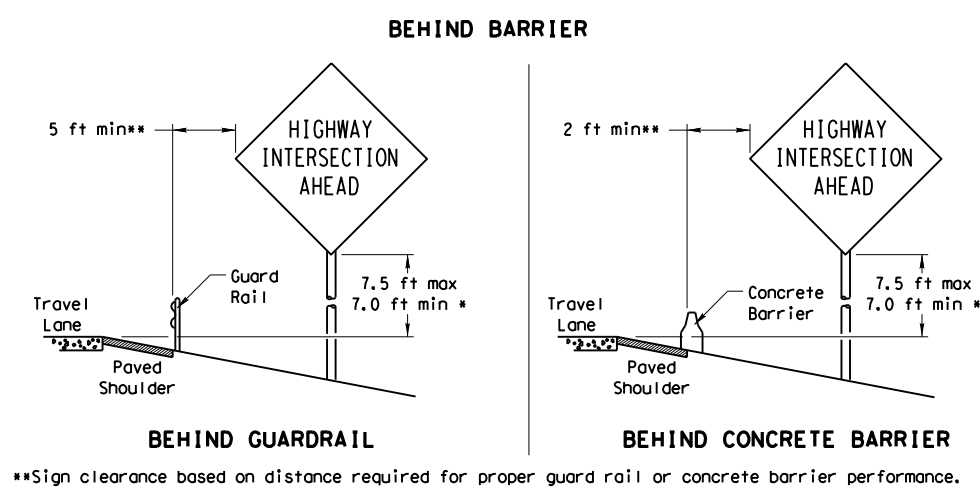
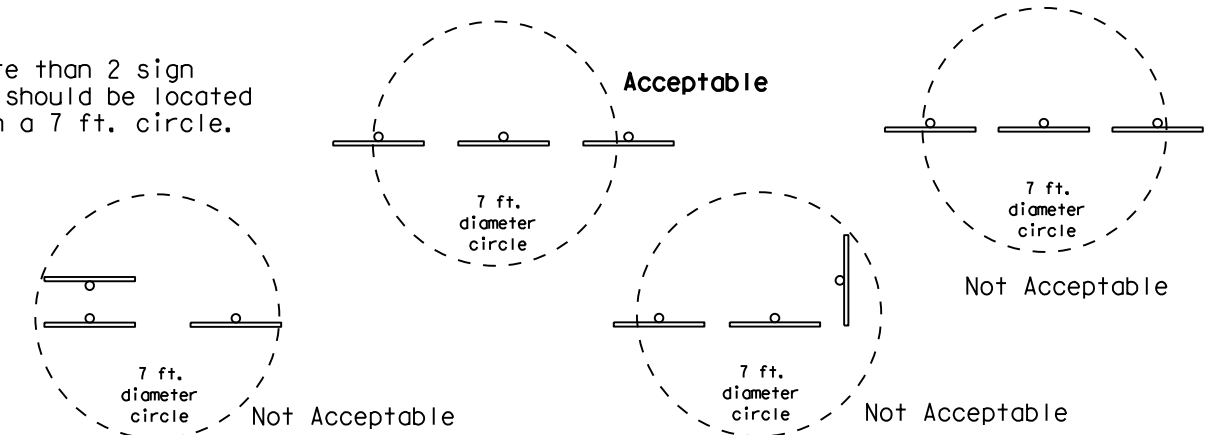

TYPICAL SIGN ATTACHMENT DETAIL

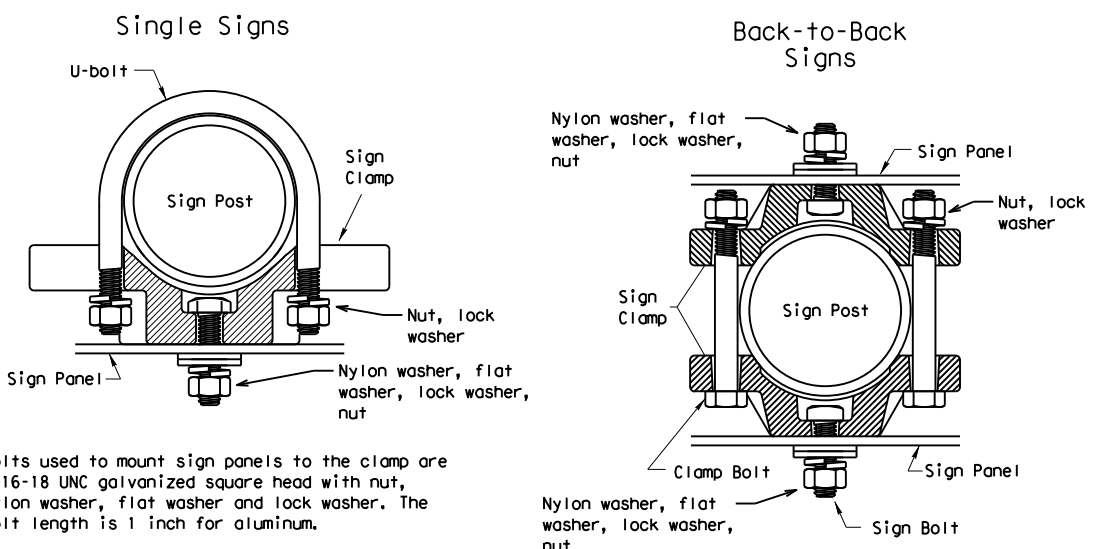

Bolts used to mount sign panels to the clamp are 5/16-18 UNC galvanized square head with nut, nylon washer, flat washer and lock washer. The bolt length is 1 inch for aluminum.

When two sign clamps are used to mount signs back-to-back, use a 5/16-18 UNC galvanized hex head per ASTM A307 with nut and helical-spring lock washer. The approximate bolt lengths for various post sizes and sign clamp types are given in the table at right. The bolt length may need to be adjusted depending upon field conditions.

Sign clamps may be either the specific size clamp or the universal clamp.

Pipe Diameter	Approximate Bolt Length	
	Specific Clamp	Universal Clamp
2" nominal	3"	3 or 3 1/2"
2 1/2" nominal	3 or 3 1/2"	3 1/2 or 4"
3" nominal	3 1/2 or 4"	4 1/2"

SIGNS WITH PLAQUES

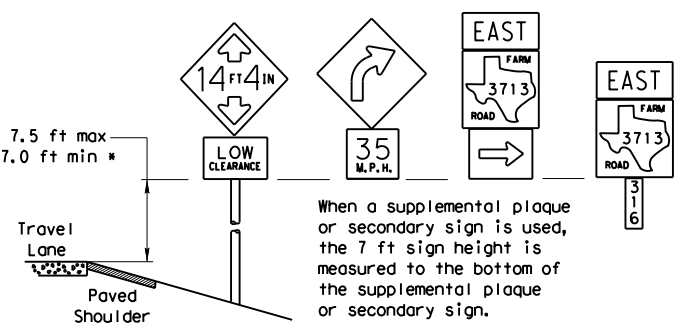

CURB & GUTTER OR RAISED ISLAND

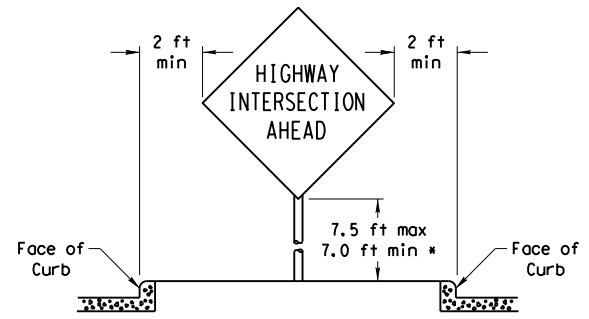

RESTRICTED RIGHT-OF-WAY (When 6 ft min. is not possible.)

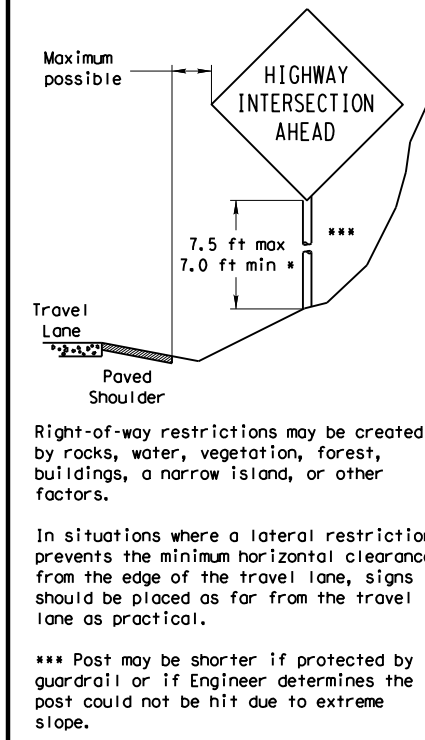

* Signs shall be mounted using the following condition that results in the greatest sign elevation:

- (1) a minimum of 7 to a maximum of 7.5 feet above the edge of the travel lane or
- (2) a minimum of 7 to a maximum of 7.5 feet above the grade at the base of the support when sign is installed on the backslope.

The maximum values may be increased when directed by the Engineer.

See the Traffic Operations Division website for detailed drawings of sign clamps, Triangular Slipbase System components and Wedge Anchor System components.

The website address is:
<http://www.txdot.gov/publications/traffic.htm>

Texas Department of Transportation
 Traffic Operations Division

SIGN MOUNTING DETAILS SMALL ROADSIDE SIGNS GENERAL NOTES & DETAILS SMD(GEN)-08

© TxDOT July 2002		DN: TxDOT	CK: TxDOT	DW: TxDOT	CK: TxDOT
9-08	REVISIONS	CONT	SECT	JOB	HIGHWAY
		0010	08	060	US 67
		DIST	COUNTY		SHEET NO.
		ATL	MORRIS		77

DISCLAIMER: The use of this standard is governed by the "Texas Engineering Practice Act". No warranty of any kind is made by TxDOT for any purpose whatsoever. TxDOT assumes no responsibility for the conversion of this standard to other formats or for incorrect results or damages resulting from its use.

DATE: 1/11/2024 3:11:12 PM
 FILE: T:\engdata\Traffic\VDG\N\192515_Jamie\JOBS\LIGHTING PROJECTS\Lighting Project May 2024\standards\smds2.dgn

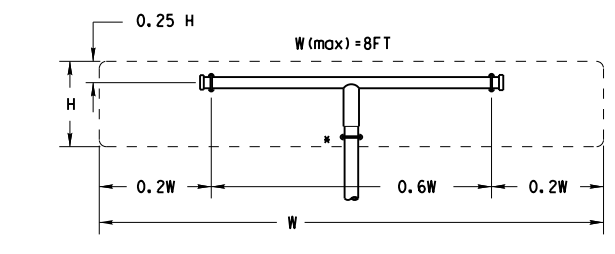
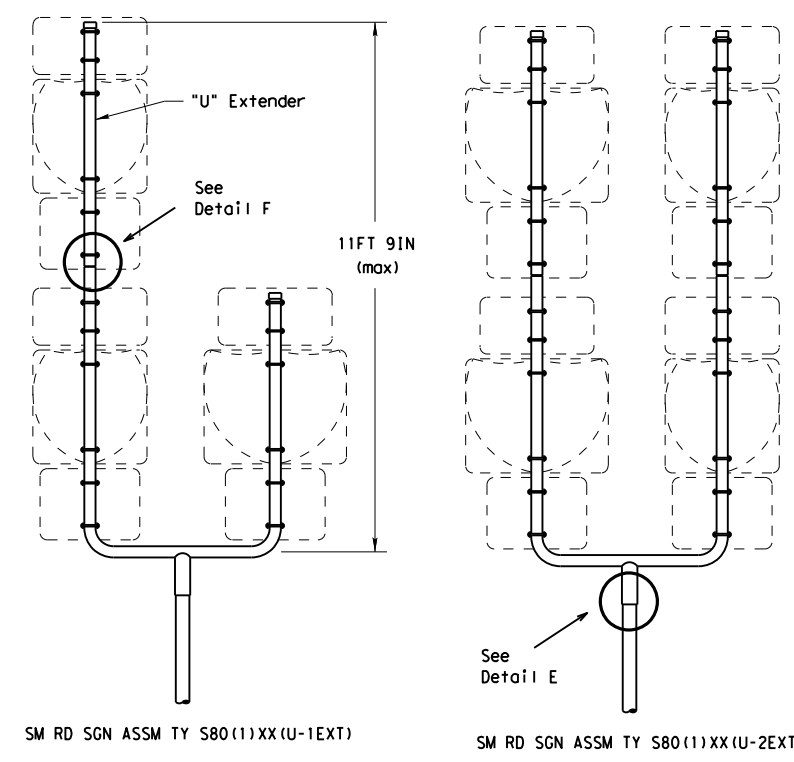
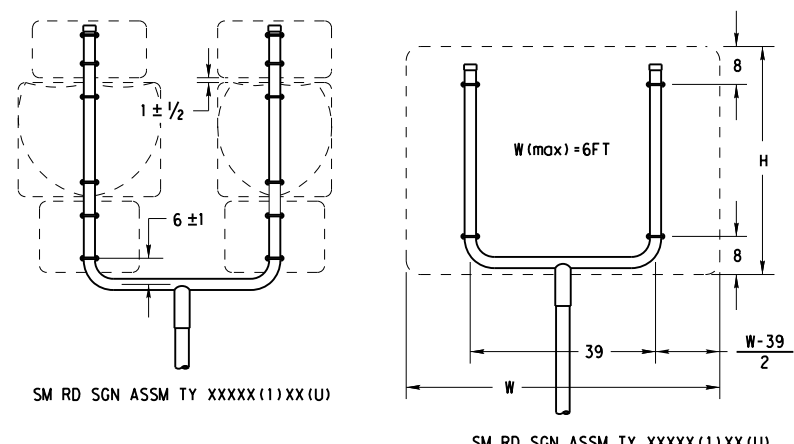
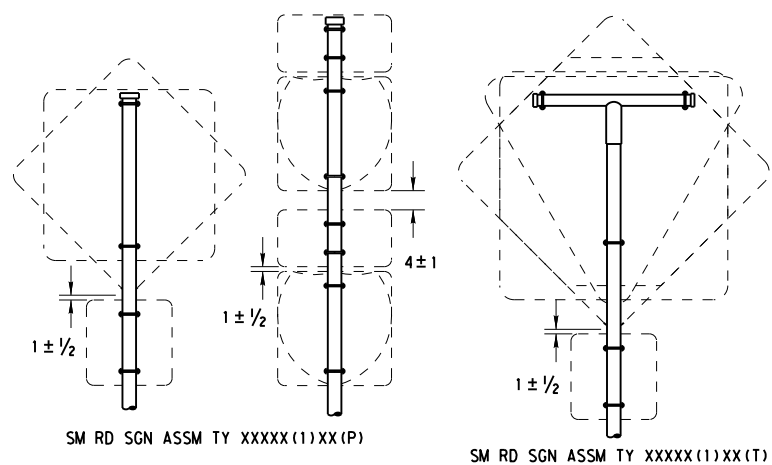

All dimensions are in english unless detailed otherwise.

SM RD SGN ASSM TY XXXX(1)XX(T) (* - See Note 12)

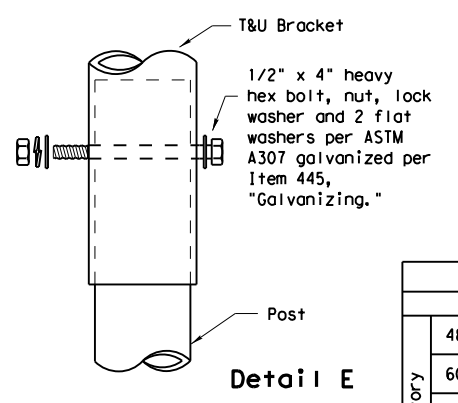
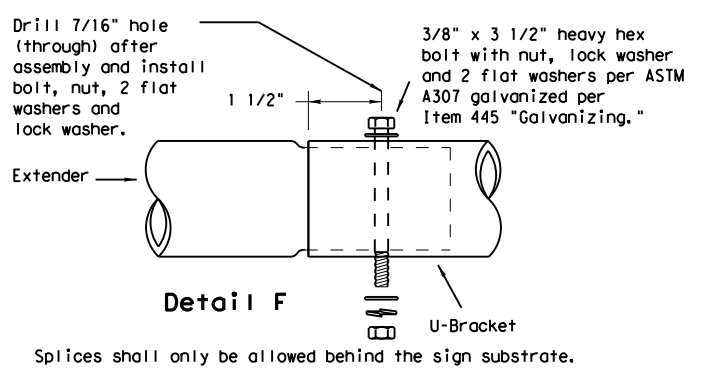
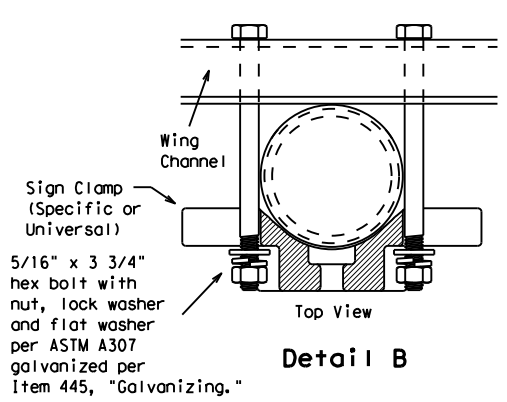
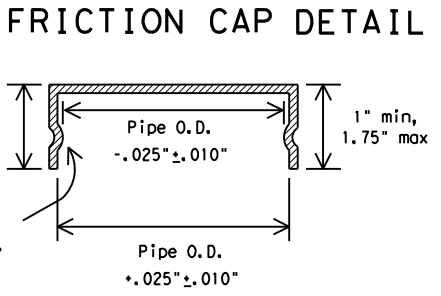
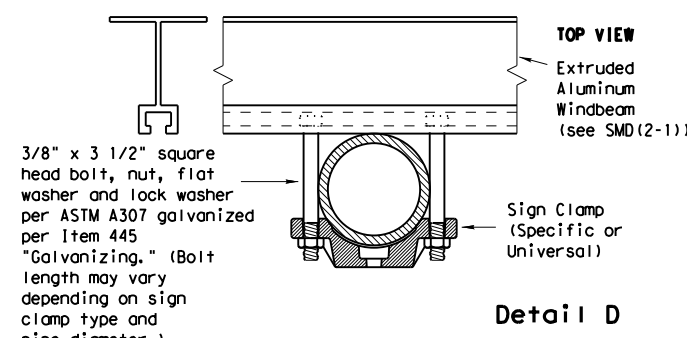
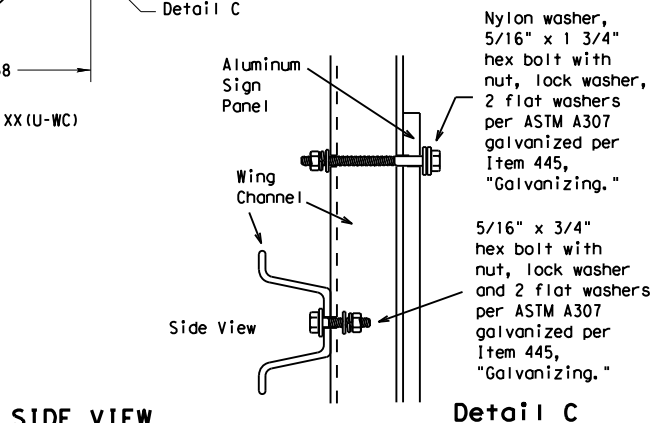
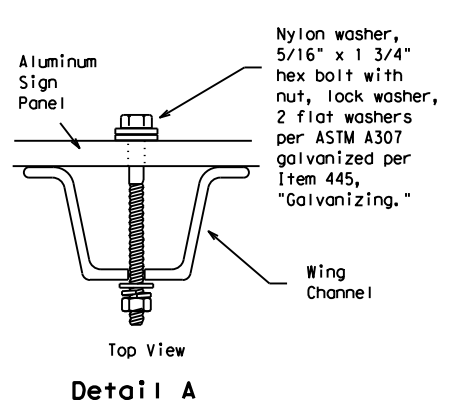
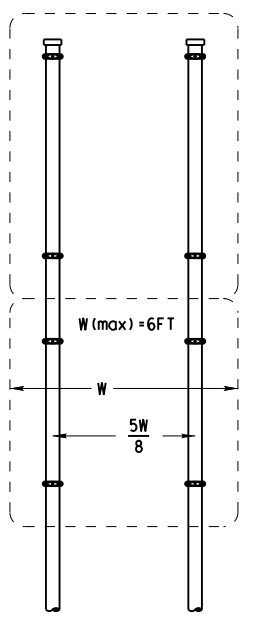
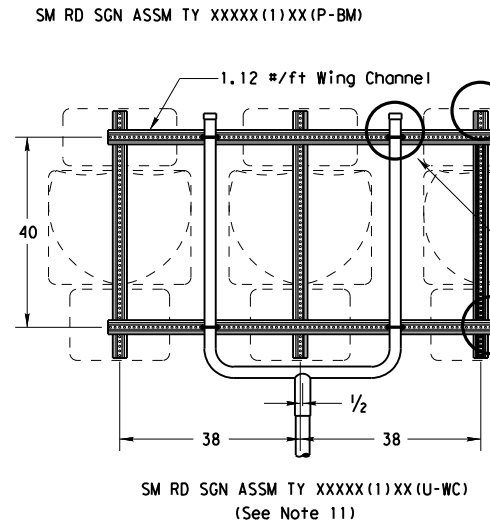
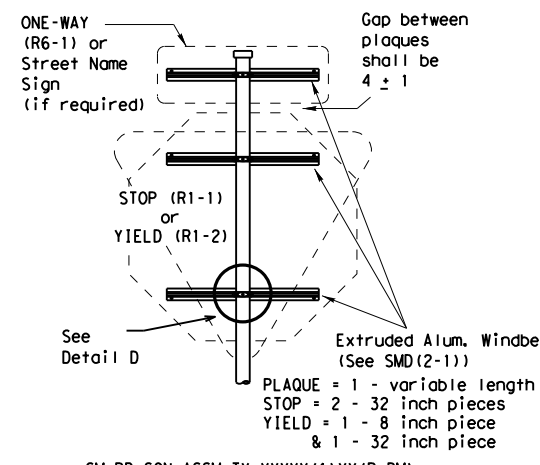

GENERAL NOTES:

1. SIGN SUPPORT # OF POSTS MAX. SIGN AREA

10 BWG	1	16 SF
10 BWG	2	32 SF
Sch 80	1	32 SF
Sch 80	2	64 SF
2. The Engineer may require that a Schedule 80 post be used in place of a 10 BWG where a sign height is abnormally high due to a fill slope.
3. Sign supports shall not be spliced except where shown. Sign support posts shall not be spliced.
4. Aluminum sign blanks shall conform to Departmental Material Specifications DMS-7110 and shall have the following minimum thicknesses: 0.080 for signs less than 7.5 sq. ft., 0.100 for signs 7.5 to 15 sq. ft., and 0.125 for signs greater than 15 sq. ft.
5. Signs that require specific supports due to reasons in addition to windloading are indicated on the "REQUIRED SUPPORT" table on this sheet.
6. For horizontal rectangular signs fabricated from flat aluminum, T-brackets are used for signs 24 inches or less in height. U-brackets are used for signs of greater height.
7. When two triangular slipbase supports are used to support a single sign, they shall not be "rigidly" connected to each other except through the sign panel. This will allow each support to act independently when impacted by an errant vehicle.
8. Wing channel shall meet ASTM A 1011 SS Gr 50 and be galvanized per ASTM A 123.
9. Excess pipe, wing channel, or windbeam shall be cut off so that it does not extend beyond the sign panel (i.e., excess support shall not be visible when the sign is viewed from the front.) Repair galvanized coating at cut support ends per Item 445, "Galvanizing."
10. Additional route markers may be added vertically, provided the total sign area does not exceed the maximum allowable amount per Note 1.
11. Additional sign clamp required on the "T-bracket" post for 24 inch height signs. Place the clamp 3 inches above bottom of sign when possible.
12. Post open ends shall be fitted with Friction Caps.
13. Sign blanks shall be the sizes and shapes shown on the plans.

REQUIRED SUPPORT		
SIGN DESCRIPTION	SUPPORT	
Regulatory	48-inch STOP sign (R1-1)	TY 10BWG(1)XX(T) TY 10BWG(1)XX(P-BM)
	60-inch YIELD sign (R1-2)	TY 10BWG(1)XX(T) TY 10BWG(1)XX(P-BM)
Warning	48x16-inch ONE-WAY sign (R6-1)	TY 10BWG(1)XX(T) TY 10BWG(1)XX(P-BM)
	36x48, 48x36, and 48x48-inch signs	TY 10BWG(1)XX(T)
	48x60-inch signs	TY S80(1)XX(T)
	48x48-inch signs (diamond or square)	TY 10BWG(1)XX(T)
	48x60-inch signs	TY S80(1)XX(T)
48-inch Advance School X-ing sign (S1-1)	TY 10BWG(1)XX(T)	
48-inch School X-ing sign (S2-1)	TY 10BWG(1)XX(T)	
Large Arrow sign (W1-6 & W1-7)	TY 10BWG(1)XX(T)	

Friction caps may be manufactured from hot rolled or cold rolled steel sheets. The minimum sheet metal thickness shall be 24 gauge for all cap sizes. The rim edges shall be reasonably straight and smooth. Caps shall be sized and formed in such a manner as to produce a drive-on friction fit and have no tendency to rock when seated on the pipe. The depth shall be sufficient to give positive protection against entrance of rainwater. They shall be free of sharp creases or indentations and show no evidence of metal fracture. Caps shall have an electrodeposited coating of zinc in accordance with the requirements of ASTM B633 Class FE/ZN 8.



**SIGN MOUNTING DETAILS
 SMALL ROADSIDE SIGNS
 TRIANGULAR SLIPBASE SYSTEM
 SMD(SLIP-2)-08**

© TxDOT July 2002		DN: TXDOT	CK: TXDOT	DW: TXDOT	CK: TXDOT
9-08	REVISIONS	CONT	SECT	JOB	HIGHWAY
		0010	08	060	US 67
		DIST	COUNTY		SHEET NO.
		ATL	MORRIS		79

DISCLAIMER: The use of this standard is governed by the "Texas Engineering Practice Act". No warranty of any kind is made by TxDOT for any purpose whatsoever. TxDOT assumes no responsibility for the conversion of this standard to other formats or for incorrect results or damages resulting from its use.

DATE: 1/11/2024 3:11:37 PM
 FILE: T:\engdata\Traffic\DG\192515_Jamie\JOBS\LIGHTING PROJECTS\Lighting Project May 2024\standards\smds3.dgn

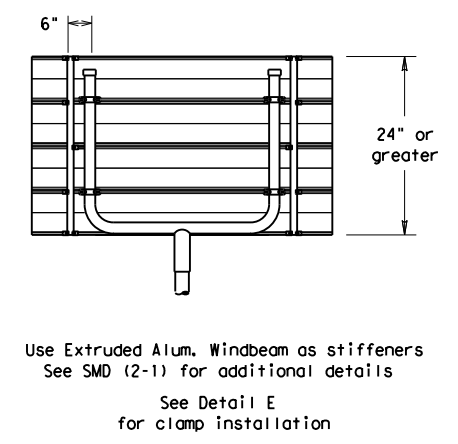
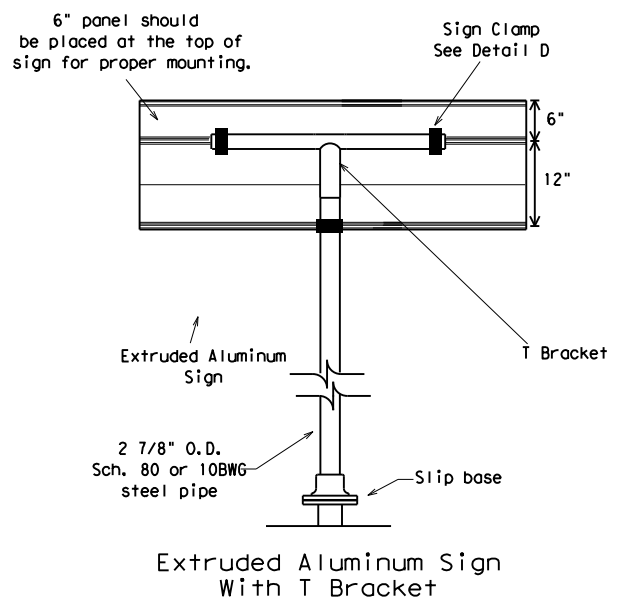
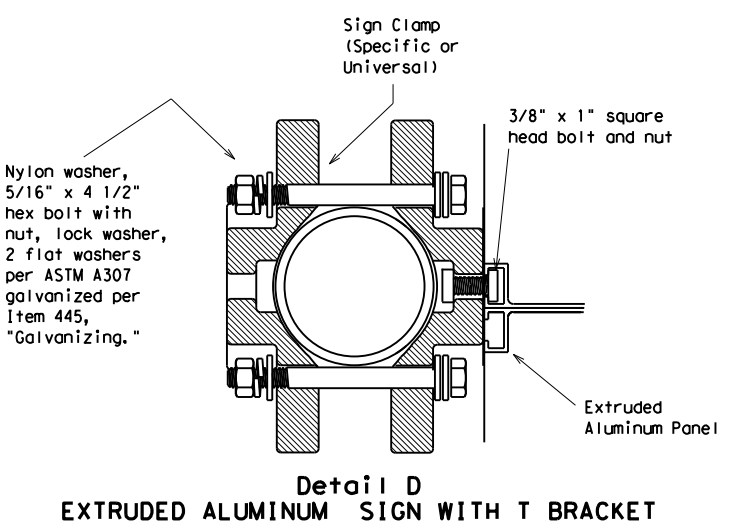
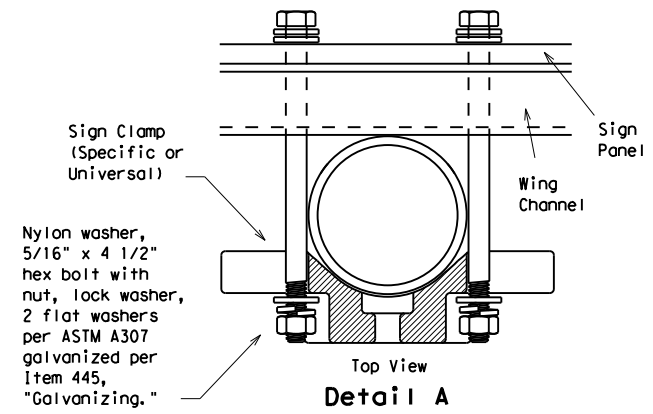
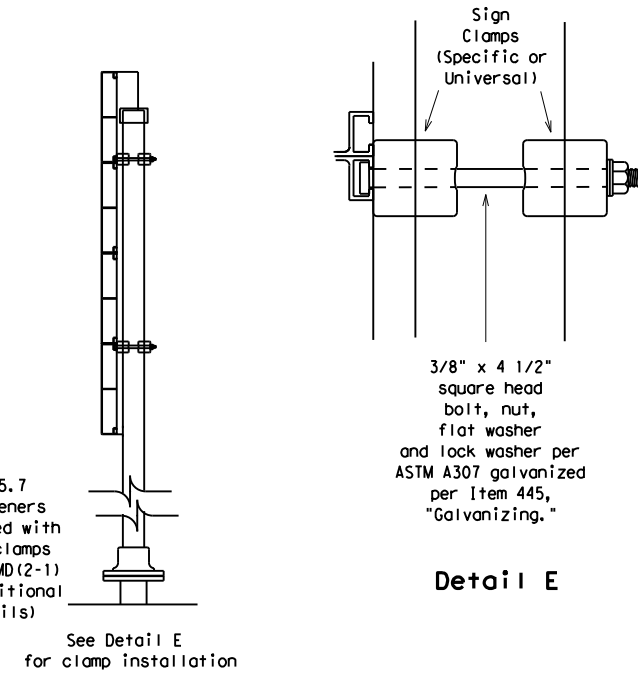
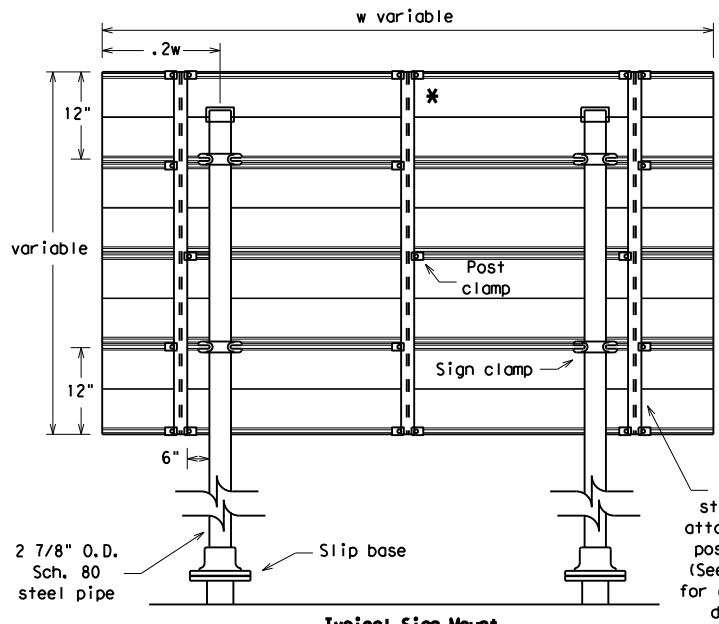
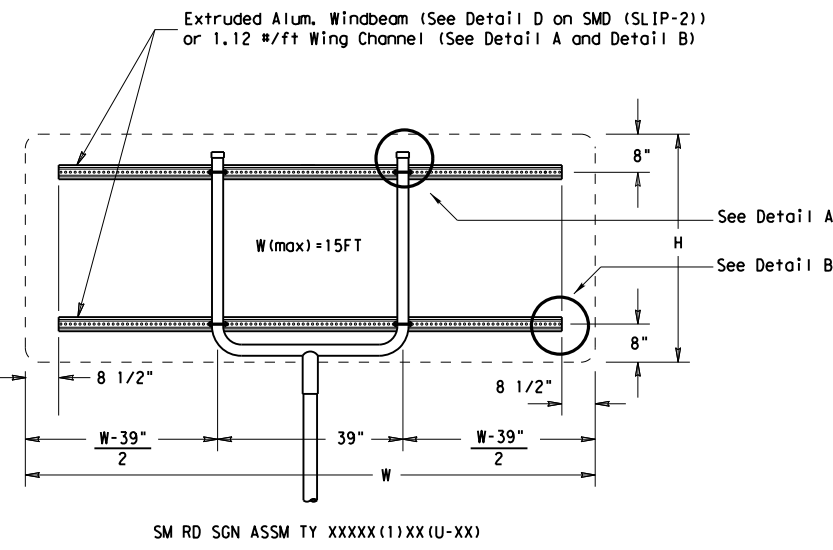
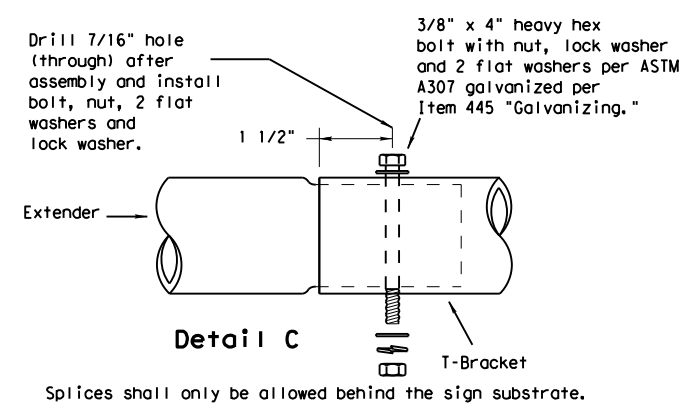
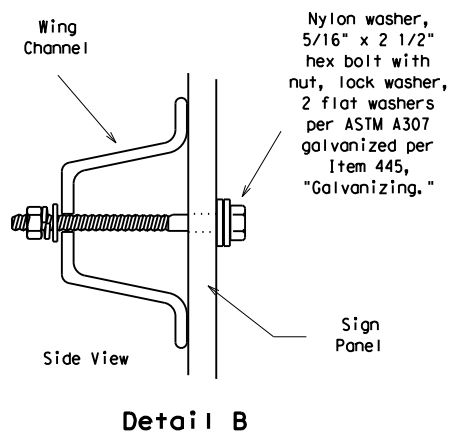
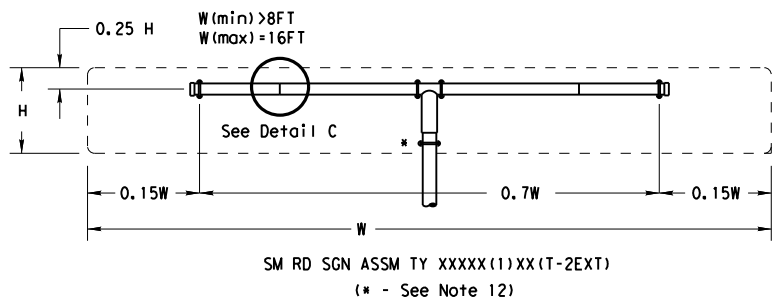

GENERAL NOTES:

- | SIGN SUPPORT | # OF POSTS | MAX. SIGN AREA |
|--------------|------------|----------------|
| 10 BWG | 1 | 16 SF |
| 10 BWG | 2 | 32 SF |
| Sch 80 | 1 | 32 SF |
| Sch 80 | 2 | 64 SF |
- The Engineer may require that a Schedule 80 post be used in place of a 10 BWG where a sign height is abnormally high due to a fill slope.
- Sign supports shall not be spliced except where shown. Sign support posts shall not be spliced.
- Aluminum sign blanks shall conform to Departmental Material Specifications DMS-7110 and shall have the following minimum thicknesses: 0.080 for signs less than 7.5 sq. ft., 0.100 for signs 7.5 to 15 sq. ft., and 0.125 for signs greater than 15 sq. ft.
- Signs that require specific supports due to reasons in addition to windloading are indicated on the "REQUIRED SUPPORT" table on this sheet.
- For horizontal rectangular signs fabricated from flat aluminum, T-brackets are used for signs 24 inches or less in height. U-brackets are used for signs of greater height.
- When two triangular slipbase supports are used to support a single sign, they shall not be "rigidly" connected to each other except through the sign panel. This will allow each support to act independently when impacted by an errant vehicle.
- Wing channel shall meet ASTM A 1011 SS Gr 50 and be galvanized per ASTM A 123.
- Excess pipe, wing channel, or windbeam shall be cut off so that it does not extend beyond the sign panel (i.e., excess support shall not be visible when the sign is viewed from the front.) Repair galvanized coating at cut support ends per Item 445, "Galvanizing."
- Sign blanks shall be the sizes and shapes shown on the plans.
- Additional sign clamp required on the "T-bracket" post for 24 inch high signs. Place the clamp 3 inches above bottom of sign when possible.
- Post open ends shall be fitted with Friction Caps.

REQUIRED SUPPORT		
	SIGN DESCRIPTION	SUPPORT
Regulatory	48-inch STOP sign (R1-1)	TY 10BWG(1)XX(T) TY 10BWG(1)XX(P-BM)
	60-inch YIELD sign (R1-2)	TY 10BWG(1)XX(T) TY 10BWG(1)XX(P-BM)
	48x16-inch ONE-WAY sign (R6-1)	TY 10BWG(1)XX(T) TY 10BWG(1)XX(P-BM)
	36x48, 48x36, and 48x48-inch signs	TY 10BWG(1)XX(T)
	48x60-inch signs	TY S80(1)XX(T)
Warning	48x48-inch signs (diamond or square)	TY 10BWG(1)XX(T)
	48x60-inch signs	TY S80(1)XX(T)
	48-inch Advance School X-ing sign (S1-1)	TY 10BWG(1)XX(T)
	48-inch School X-ing sign (S2-1)	TY 10BWG(1)XX(T)
	Large Arrow sign (W1-6 & W1-7)	TY 10BWG(1)XX(T)



**SIGN MOUNTING DETAILS
 SMALL ROADSIDE SIGNS
 TRIANGULAR SLIPBASE SYSTEM
 SMD(SLIP-3)-08**

© TxDOT July 2002		DN: TxDOT	CK: TxDOT	DW: TxDOT	CK: TxDOT
9-08	REVISIONS	CONT	SECT	JOB	HIGHWAY
		0010	08	060	US 67
		DIST	COUNTY		SHEET NO.
		ATL	MORRIS		80

DATE: 1/11/2024 3:12:04 PM
 FILE: I:\Engdata\Traffic\DG\N\192515_Jamie\JOBS\LIGHTING PROJECTS\Lighting Project May 2024\standards\smdw.t.dgn
 DISCLAIMER: The use of this standard is governed by the "Texas Engineering Practice Act". No warranty of any kind is made by TxDOT for any purpose whatsoever. TxDOT assumes no responsibility for the conversion of this standard to other formats or for incorrect results or damages resulting from its use.

Wedge Anchor Steel System

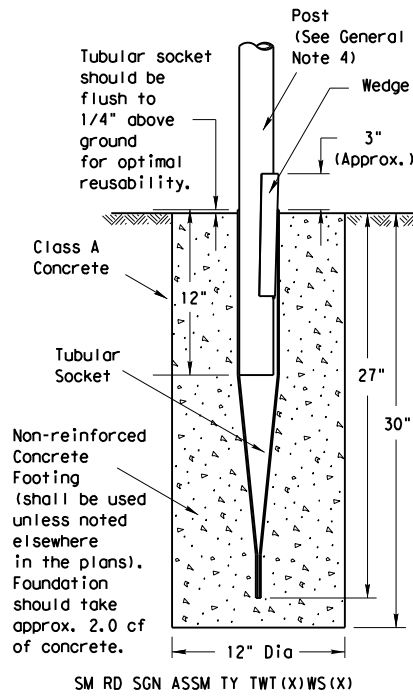

Wedge Anchor High Density Polyethylene (HDPE) System

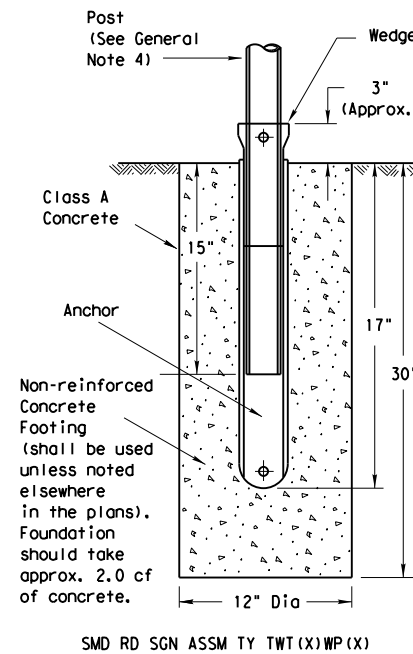

Universal Anchor System with Thin-Walled Tubing Post

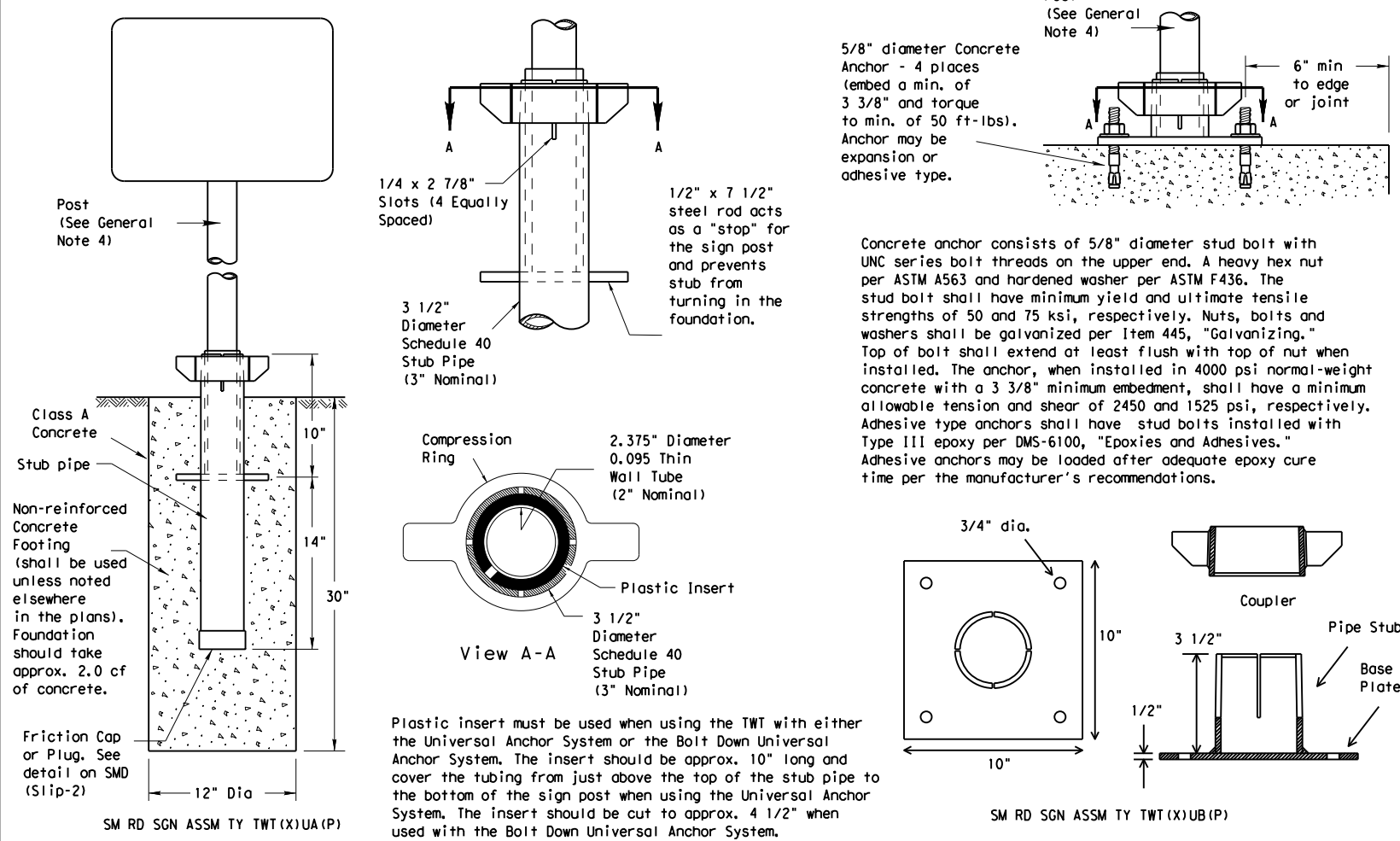

Sign Installation Using a Prefabricated T-Bracket for Thin-Wall Tubing Post

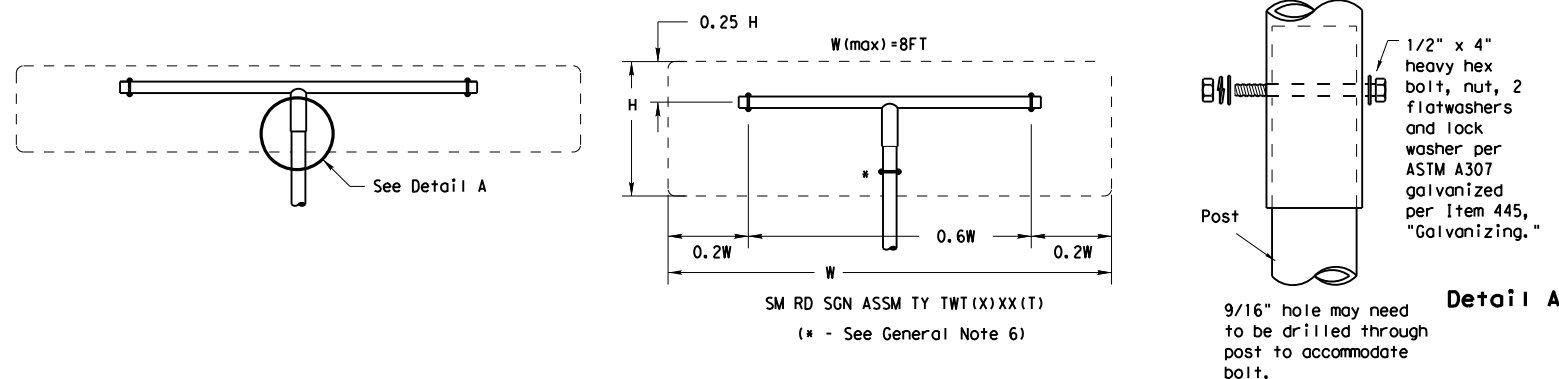

NOTE
 The devices shall be installed per manufacturer's recommendations. Installation procedures shall be provided to the Engineer by Contractor.

GENERAL NOTES:

- The Wedge Anchor System and the Universal Anchor System with thin wall tubing post may be used to support up to 10 square feet of sign area.
- The tubular socket, wedge and prefabricated T-bracket shall be permanently marked to indicate manufacturer. Method, design, and location of marking are subject to the approval of the TxDOT Traffic Standards Engineer.
- Except for posts (13 BWG Tubing), clamps, nuts and bolts, all components shall be prequalified. A list of prequalified vendors may be obtained from the Material Producer List web page. The website address is: http://www.txdot.gov/business/producer_list.htm
- Material used as post with this system shall conform to the following specifications:
 - 13 BWG Tubing (2.375" outside diameter) (TWT)
 - 0.095" nominal wall thickness
 - Seamless or electric-resistance welded steel tubing
 - Steel shall be HSLA Gr 55 per ASTM A1011 or ASTM A1008
 - Other steels may be used if they meet the following:
 - 55,000 PSI minimum yield strength
 - 70,000 PSI minimum tensile strength
 - 18% minimum elongation in 2"
 - Wall thickness (uncoated) shall be within the range of .083" to .099"
 - Outside diameter (uncoated) shall be within the range of 2.369" to 2.381"
 - Galvanization per ASTM 123 or ASTM A653 G210. For precoated steel tubing (ASTM A653), recoat tube outside diameter weld seam by metallizing with zinc wire per ASTM B833.
- Sign blanks shall be the sizes and shapes shown on the plans.
- Additional sign clamp required on the "T-bracket" post for 24" high signs. Place clamp at least 3" above bottom of sign when possible.
- Sign supports shall not be spliced except where shown. Sign support posts shall not be spliced.
- See the Traffic Operations Division website for detailed drawings of sign clamps and Wedge Anchor System components. The website address is: <http://www.txdot.gov/publications/traffic.htm>

WEDGE ANCHOR SYSTEM INSTALLATION PROCEDURE

- Dig foundation hole. Where solid rock is encountered at ground level, the foundation shall be a minimum depth of 18". When solid rock is encountered below ground level, the foundation shall extend in the solid rock a minimum depth of 18" or provide a minimum foundation depth of 30". If solid rock is encountered, the socket/stub may be reduced in length as required to a minimum length of 18". Any material removed from the socket/stub shall be from the bottom and the clearance requirements given on SMD(GEN) must be followed. The inner surfaces of the socket/stub must remain free of concrete or other debris.
- The Engineer may permit batches of concrete less than 2 cubic yards to be mixed with a portable, motor driven concrete mixer. For small placements less than 0.5 cubic yards, hand mixing in a suitable container may be allowed by Engineer. Place concrete into hole until it is approximately flush with the ground. Concrete shall be Class A.
- Insert tubular socket into concrete until top of socket is approximately 1/4" above the concrete footing.
- Plumb the socket. Allow a minimum 4 days for concrete to set, unless otherwise directed by Engineer.
- Attach the sign to the sign post.
- Insert the sign post into socket and align sign face with roadway.
- Drive the wedge into the socket to secure post. This will leave approximately 3 inches of the wedge exposed.

UNIVERSAL ANCHOR SYSTEM INSTALLATION PROCEDURE

- Dig foundation hole. Where solid rock is encountered at ground level, the foundation shall be a minimum depth of 18". When solid rock is encountered below ground level, the foundation shall extend in the solid rock a minimum depth of 18" or provide a minimum foundation depth of 30". If solid rock is encountered, the socket/stub may be reduced in length as required to a minimum length of 18". Any material removed from the socket/stub shall be from the bottom and the clearance requirements given on SMD(GEN) must be followed. The inner surfaces of the socket/stub must remain free of concrete or other debris.
- Insert base post in hole to depths shown and backfill hole with concrete.
- Level and plumb the base post using a torpedo level and allow concrete adequate time to set. The bottom of the slots provided in the stub pipe shall remain above the top of the concrete foundation.
- Attach the sign to the sign post.
- Install plastic insert around bottom of post.
- Insert sign post into base post. Lower until the post comes to rest on steel rod.
- Seat compression ring using a hammer. Typically, the top of compression ring will be approximately level with top of stub post when optimally installed.
- Check sign post by hand to ensure it is unable to turn. If loose, increase the tightening of the compression ring.



SIGN MOUNTING DETAILS SMALL ROADSIDE SIGNS WEDGE & UNIVERSAL ANCHOR WITH THIN WALL TUBING POST SMD(TWT) - 08

© TxDOT July 2002	DN: TxDOT	CK: TxDOT	DW: TxDOT	CK: TxDOT	
9-08	REVISIONS	CONT	SECT	JOB	HIGHWAY
		0010	08	060	US 67
		DIST	COUNTY	SHEET NO.	
		ATL	MORRIS	81	

DATE: 1/11/2024 3:12:31 PM
 FILE: T:\engdata\Traffic\UGM\192515_Jamie\JOBS\LIGHTING PROJECTS\Lighting of off-ramps on I-37\192515-01.dwg
 The use of this standard is governed by the "Texas Engineering Practice Act". No warranty of any kind is made by TxDOT for any purpose whatsoever. TxDOT assumes no responsibility for the conversion of drawings to PDF or for any errors or omissions in the drawings or for any damages resulting from its use.

GENERAL NOTES FOR ALL ELECTRICAL WORK

- The location of all conduits, junction boxes, ground boxes, and electrical services is diagrammatic and may be shifted to accommodate field conditions.
- Provide new and unused materials. Ensure that all materials and installations comply with the applicable articles of the National Electrical Code (NEC), TxDOT standards and specifications, National Electrical Manufacturers Association (NEMA), and are listed by Underwriters Laboratories (UL) or a Nationally Recognized Testing Lab (NRTL). NRTLs such as Canadian Standard Association (CSA), Intertek Testing Services NA Inc., or FM Approvals LLC can be considered equivalent to UL. Where reference is made to NEMA listed devices, International Electrotechnical Commission (IEC) listed devices will not be considered an acceptable equal to a NEMA listed device. Acceptable devices may have both a NEMA and IEC listing. Faulty fabrication or poor workmanship in any material, equipment, or installation is justification for rejection. Replace or reinstall rejected material or equipment at no additional cost to the Department.
- Miscellaneous nuts, bolts and hardware, except for high strength bolts, may be stainless steel when plans specify galvanized, provided the bolt size is 1/2 in. or less in diameter.
- Provide the following test equipment as required by the Engineer to confirm compliance with the contract and the NEC: voltmeter, ammeter, megohm meter (1000 volt DC), ground resistance tester, torque wrenches, and torque screwdrivers. Ensure all equipment has been properly calibrated within the last year. Provide calibration certification to the Engineer upon request. Operate test equipment during inspection as requested by the Engineer.
- Install grounding as shown on the plans and in accordance with the NEC. Ensure all metallic conduits; metal poles; luminaires; and metal enclosures are bonded to the equipment grounding conductor. Provide stranded bare copper or green insulated grounding conductors. Ground rods, connectors, and bonding jumpers are subsidiary to the various bid items.
- When required by the Engineer, notify the Department in writing of materials from the Material Producers List (MPL) intended for use on each project. Prequalified materials are listed on the MPL on TxDOT's website under "Roadway Illumination and Electrical Supplies." No substitutions will be allowed for materials on this list.

CONDUIT

A. MATERIALS

- Provide conduit, junction boxes, fittings, and hardware as per TxDOT Departmental Material Specification (DMS) 11030 "Conduit" and Item 618 "Conduit" of TxDOT's "Standard Specifications For Construction And Maintenance Of Highways, Streets, And Bridges," latest edition. Provide conduits listed under Item 618 on the MPL under "Roadway Illumination and Electrical Supplies." Provide conduit types according to the descriptive code or as shown on the plans. Do not substitute other types of conduits for those shown. Provide liquidtight flexible metal conduit (LFMC) when flexible conduit is called for on galvanized steel rigid metallic conduit (RMC) systems. Provide liquidtight flexible nonmetallic conduit (LFNC) when flexible conduit is called for on polyvinyl chloride (PVC) systems.
- Provide galvanized steel RMC for all exposed conduits, unless otherwise shown on the plans. Properly bond all metal conduits.
- Unless otherwise shown on the plans, provide junction boxes with a minimum size as shown in the following table, which applies to the greatest number of conductors entering the box through one conduit with no more than four conduits per box. When a mixture of conductor sizes is present, count the conductors as if all are of the larger size. For situations not applicable to the table, size junction boxes in accordance with NEC.



AWG	3 CONDUCTORS	5 CONDUCTORS	7 CONDUCTORS
#1	10" x 10" x 4"	12" x 12" x 4"	16" x 16" x 4"
#2	8" x 8" x 4"	10" x 10" x 4"	12" x 12" x 4"
#4	8" x 8" x 4"	10" x 10" x 4"	10" x 10" x 4"
#6	8" x 8" x 4"	8" x 8" x 4"	10" x 10" x 4"
#8	8" x 8" x 4"	8" x 8" x 4"	8" x 8" x 4"

- Junction boxes with an internal volume of less than 100 cu. in. and supported by entering raceways must have threaded entries or hubs identified for the intended purpose and supported by connection of two or more rigid metal conduits. Secure conduit within 3 ft. of the enclosure or within 18 in. of the enclosure if all conduit entries are on the same side. Mechanically secure all junction boxes with an internal volume greater than 100 cu. inches.
- Provide hot dipped galvanized cast iron or sand cast aluminum outlet boxes for junction boxes containing only 10 AWG or 12 AWG conductors. Do not use die cast aluminum boxes. Size outlet boxes according to the NEC.
- Do not use intermediate metal conduit (IMC) or electrical metallic tubing (EMT) unless specifically required by the plan sheets. When EMT is called for, provide junction boxes made from galvanized steel sheeting, listed and approved for outdoor use, unless otherwise noted on the plans. Size all galvanized steel junction boxes in accordance with the NEC. Provide junction boxes for IMC conduit systems that meet the same requirements for junction boxes used with RMC systems.
- Provide PVC junction boxes intended for outdoor use on PVC conduit systems, unless otherwise noted on the plans.

- Provide PVC elbows in PVC conduit systems, unless otherwise shown on the plans. Use only a flat, high tensile strength polyester fiber pull tape for pulling conductors through the PVC conduit system. When galvanized steel RMC elbows are specifically called for in the plans and any portion of the RMC elbow is buried less than 18 in., ground the RMC elbow by means of a grounding bushing on a rigid metal extension. Grounding of the rigid metal elbow is not required if the entire RMC elbow is encased in a minimum of 2 in. of concrete. PVC extensions are allowed on these concrete encased rigid metal elbows. RMC or PVC elbows are subsidiary to various bid items.
- When required, provide High-Density Polyethylene (HDPE) conduit with factory installed internal conductors according to Item 622 "Duct Cable." At the Contractor's request and with approval by the Engineer, substitute HDPE conduit with no conductors for bored schedule 40 or schedule 80 PVC conduit bid under Item 618. Ensure bored HDPE substituted for PVC is schedule 40 and of the same size PVC called for in the plans. Ensure the substituted HDPE meets the requirements of Item 622, except that the conduit is supplied without factory-installed conductors. Make the transition of the HDPE conduit to PVC (or RMC elbow when required) at the bore pit. Provide conduit of the size and schedule as shown on the plans. Do not extend substituted conduit into ground boxes or foundations. Provide PVC or galvanized steel RMC elbows as called for at all ground boxes and foundations.
- Use two-hole straps when supporting 2 in. and larger conduits. On electrical service poles, properly sized stainless steel or hot dipped galvanized one-hole standoff straps are allowed on the service riser conduit.

B. CONSTRUCTION METHODS

- Provide and install expansion joint conduit fittings on all structure-mounted conduits at the structure's expansion joints to allow for movement of the conduit. In addition, provide and install expansion joint fittings on all continuous runs of galvanized steel RMC conduit externally exposed on structures such as bridges at maximum intervals of 150 ft. When requested by the project Engineer, supply manufacturer's specification sheet for expansion joint conduit fittings. Repair or replace expansion joint fittings that do not allow for movement at no additional cost to the Department. Provide the method of determining the amount of expansion to the Engineer upon request. Do not use LFMC or LFNC as a substitute for the required expansion conduit fittings.
- Space all conduit supports at maximum intervals of 5 ft. Install conduit spacers when attaching metal conduit to surface of concrete structures. See "Conduit Mounting Options" on ED(2). Install conduit support within 3 ft. of all enclosures and conduit terminations.
- Do not attach conduit supports directly to pre-stressed concrete beams except as shown specifically in the plans or as approved by the Engineer.
- Unless otherwise shown on the plans, jack or bore conduit placed beneath existing roadways, driveways, sidewalks, or after the base or surfacing operation has begun. Backfill and compact the bore pits below the conduit per Item 476 "Jacking, Boring, or Tunneling Pipe or Box" prior to installing conduit or duct cable to prevent bending of the connections.
- When placing conduit in the sub-grade of new roadways, backfill all trenches with excavated material unless otherwise noted on the plans. When placing conduit in the sub-base of new roadways, backfill all trenches with cement-stabilized base as per requirements of Items 110 "Excavation", 400 "Excavation and Backfill for Structures", 401 "Flowable Backfill", 402 "Trench Excavation Protection", and 403 "Temporary Special Shoring."
- Provide and place warning tape approximately 10 in. above all trenched conduit as per Item 618.
- During construction, temporarily cap or plug open ends of all conduit and raceways immediately after installation to prevent entry of dirt, debris and animals. Temporary caps constructed of durable duct tape are allowed. Tightly fix the tape to the conduit opening. Clean out the conduit and prove it clear in accordance with Item 618 prior to installing any conductors.
- Ensure conduit entry into the top of any enclosure is waterproof by installing conduit sealing hubs or using boxes with threaded bosses. This includes surface mounted safety switches, meter cans, service enclosures, auxiliary enclosures and junction boxes. Grounding bushings on water tight sealing hubs are not required.
- Fit the ends of all PVC conduit terminations with bushings or bell end fittings. Provide and install a grounding type bushing on all metal conduit terminations.
- Install a bonding jumper from each grounding bushing to the nearest ground rod, grounding lug, or equipment grounding conductor. Ensure all bonding jumpers are the same size as the equipment grounding conductor. Bonding of conduit used as a casing under roadways for duct cable is not required, if the duct extends the full length through the casing.
- At all electrical services, install a 6 AWG solid copper grounding electrode conductor.
- Place conduits entering ground boxes so that the conduit openings are between 3 in. and 6 in. from the bottom of the box. See the ground box detail on sheet ED(4).
- Seal ends of all conduits with duct seal, expandable foam, or by other methods approved by the Engineer. Seal conduit immediately after completion of conductor installation and pull tests. Do not use duct tape as a permanent conduit sealant. Do not use silicone caulk as a conduit sealant.
- File smooth the cut ends of all mounting strut and conduit. Before installing, paint the field cut ends of all mounting strut and RMC (threaded or non-threaded) with zinc rich paint (94% or more zinc content) to alleviate overspray. Use zinc rich paint to touch up galvanized material as allowed under Item 445 "Galvanizing." Do not paint non-galvanized material with a zinc rich paint as an alternative for materials required to be galvanized.

			
<h1>ELECTRICAL DETAILS CONDUITS & NOTES</h1>			
<h2>ED(1) - 14</h2>			
FILE:	ed1-14.dgn	DWG:	CK:
© TxDOT	October 2014	CONT	SECT
REVISIONS		0010	08
		JOB	
		US 67	
		DIST	COUNTY
		ATL	MORRIS
		SHEET NO.	
		82	

DISCLAIMER: The use of this standard is governed by the "Texas Engineering Practice Act". No warranty of any kind is made by TxDOT for any purpose whatsoever. TxDOT assumes no responsibility for the conversion of units or for any errors or omissions in this drawing. TxDOT is not responsible for any incorrect results or damages resulting from its use.

DATE: 1/11/2024 3:13:01 PM
 FILE: T:\Engdat\Traffic\Lighting\PROJECTS\Lighting\2024\2024-01-11\2024-01-11-01.dgn

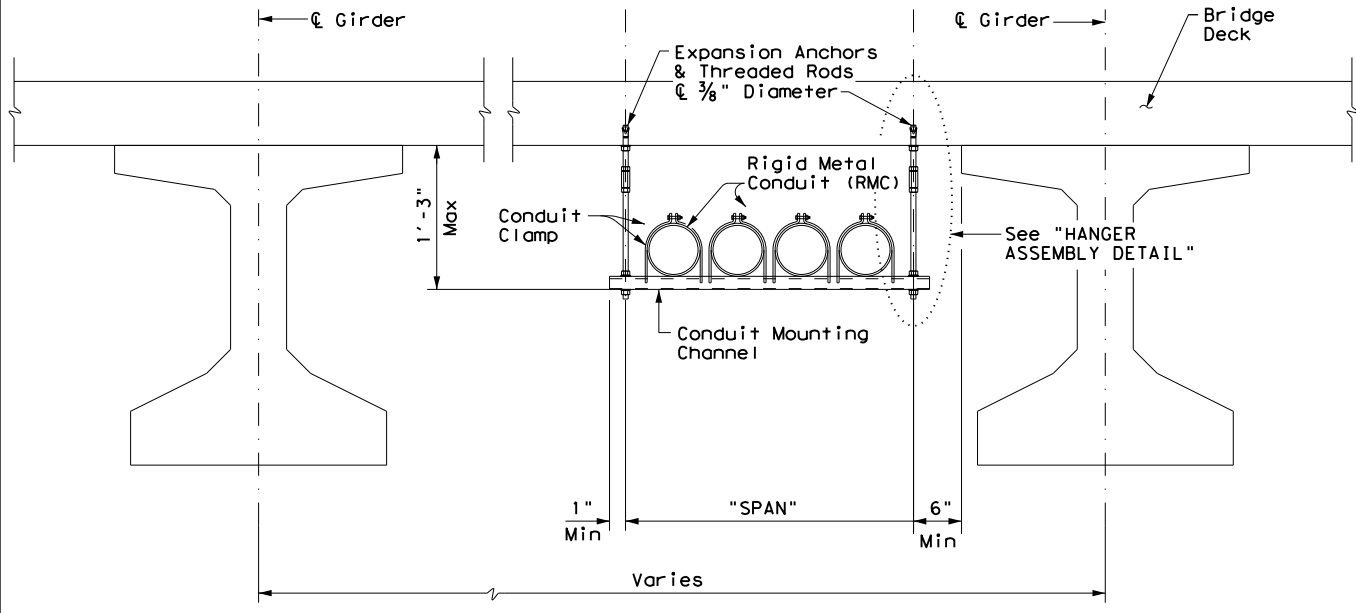

CONDUIT HANGING DETAIL

CONDUIT MOUNTING CHANNEL		
"SPAN"	"W" x "H"	"T"
less than 2'	1 5/8" x 1 3/8"	12 Ga.
2'-0" to 2'-6"	1 5/8" x 1 5/8"	12 Ga.
>2'-6" to 3'-0"	1 5/8" x 2 1/16"	12 Ga.

Channels with round or short slotted hole patterns are allowed, if the load carrying capacity is not reduced by more than 15%.

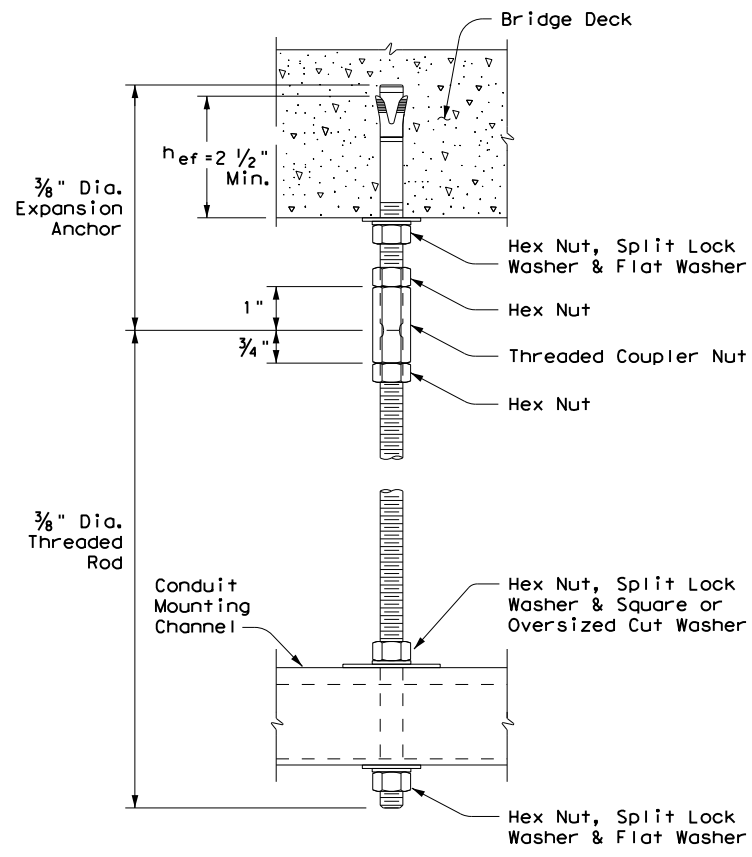
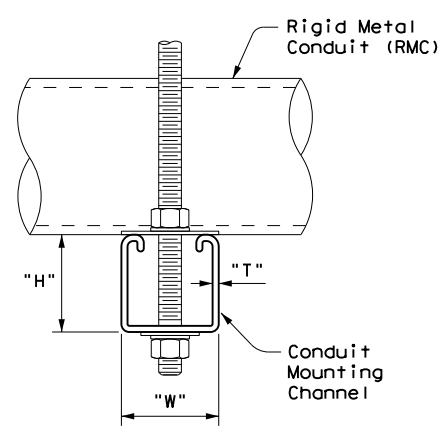

HANGER ASSEMBLY DETAIL

ELECTRIC CONDUIT TO BRIDGE DECK ATTACHMENT

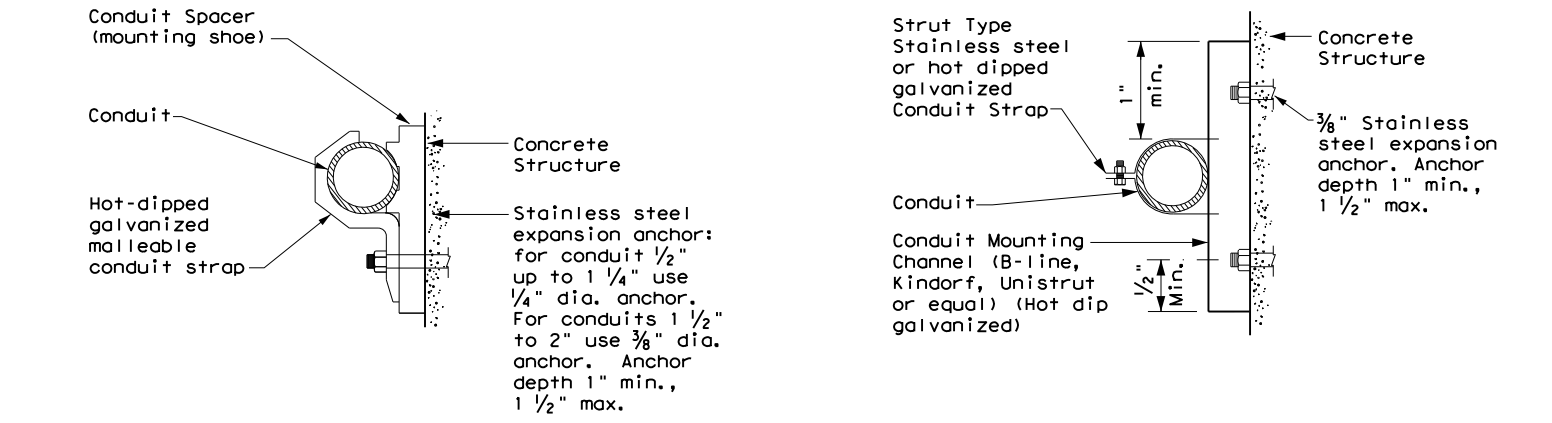

CONDUIT MOUNTING OPTIONS

Attachment to concrete surfaces
 See ED(1)B.2

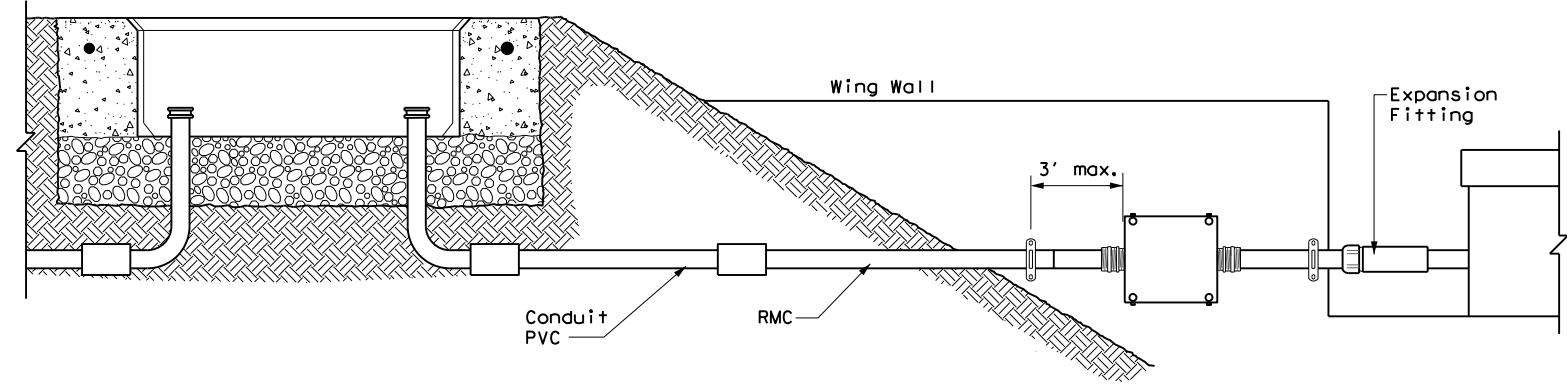

TYPICAL CONDUIT ENTRY TO BRIDGE STRUCTURE DETAIL

EXPANSION ANCHOR NOTES FOR BRIDGE DECK ATTACHMENT

1. Use torque controlled mechanical expansion anchors that are approved for use in cracked concrete by the International Code Council, Evaluation Service (ICC-ES). The chosen anchor product shall have a designated ICC-ES Evaluation Report number, and its approval status shall be maintained on the ICC-ES website under Division 031600 for Concrete Anchors.
2. Unless otherwise approved by the Engineer: do not use adhesive anchors; do not use expansion anchors that are not included in the ICC-ES approval list; and do not use expansion anchors that are only approved for use in uncracked concrete.
3. Use anchors manufactured with stainless steel expansion wedges. Anchors manufactured with carbon steel expansion wedges are not allowed. Anchor bodies can be either zinc-plated carbon steel or stainless steel. For application in marine environment, both the anchor body and expansion wedge shall be stainless steel.
4. Install anchors as shown on the plans and in accordance with the anchor manufacturer's published installation instructions. Arrange a field demonstration test to evaluate the procedures and tools. The test shall be witnessed and approved by the Engineer prior to furnishing anchors on the structure.
5. Prior to hole drilling, use rebar locator to ensure clearing of existing deck strands or reinforcement. Install anchors to ensure a minimum effective embedment depth, (h_{ef}), as shown. Increase (h_{ef}) as needed to ensure sufficient thread length for proper torquing and tightening of anchors.
6. Use anchors of minimum 1600 Lbs tensile capacity (minimum of steel, concrete breakout, and concrete pullout strengths as determined by ACI 318 Appendix D) at the required minimum embedment depth (h_{ef}). No lateral loads shall be introduced after conduit installation.

		Traffic Operations Division Standard	
<h2>ELECTRICAL DETAILS CONDUIT SUPPORTS</h2>			
<h3>ED(2) - 14</h3>			
FILE: ed2-14.dgn	DN: TxDOT	CK: TxDOT	DW: TxDOT
© TxDOT October 2014	CONT: 0010	SECT: 08	JOB: 060
REVISIONS	US: 67	DIST: ATL	COUNTY: MORRIS
			SHEET NO.: 83

ELECTRICAL CONDUCTORS

A. MATERIAL INFORMATION

1. Provide Type XHHW insulated conductors in accordance with Departmental Material Specification (DMS) 11040 "Conductors" and Item 620 "Electrical Conductors." Provide conductors as listed on the Material Producers List (MPL) on the Department web site under "Roadway Illumination and Electrical Supplies" Item 620. Color code insulated conductors in conformance with the NEC. Identify grounded (neutral) conductors with white insulation. Identify grounding conductors (ground wires) with green insulation or bare conductors. Identify ungrounded (hot) conductors with any color insulation except green, white, or gray. Keep color scheme consistent throughout the wiring system. Identify conductors 6 American Wire Gauge (AWG) and smaller by continuous color jacket. Identify electrical conductors 4 AWG and larger by continuous color jacket or by colored tape. When identifying conductors with colored tape, mark at least 6 in. of the conductor's insulation with half laps of tape.
2. Provide a solid copper 6 AWG grounding electrode conductor to bond the electrical service equipment to the concrete encased grounding electrode or the ground rod at the service location. Connect the grounding electrode conductor to the ground rod with a UL listed connector in accordance with DMS 11040. Connect the grounding electrode conductor to the concrete encased grounding electrode as shown in the plans.
3. Where two or more circuits are present in one conduit or enclosure, permanently identify the conductors of each branch circuit by attaching a non-metallic tag around both circuit conductors at each accessible location. Provide tags with two straps, large enough to indicate circuit number, letter, or other identification as shown in the plans. Print circuit identification on the tag with a permanent marker.
4. Use listed compression or screw type pressure connectors, terminal blocks, or split bolt connectors for splicing as specified in DMS 11040. Use hot melt adhesive tape to fill the gap and seal the ends of heat shrink tubing. Provide UL listed gel-filled insulating splice covers. Splicing materials, insulating materials, breakaway disconnects, splice covers, and fuse holders are subsidiary to various bid items.

B. CONSTRUCTION METHODS

1. Use only a flat, high tensile strength polyester fiber pull tape for pulling conductors through the conduit system. After installing conductors in conduit, perform conductor pull test. If a conductor cannot be freely pulled, make any needed alterations or repairs at no additional cost to the department. Perform insulation resistance tests in accordance with Item 620. Coordinate with the Engineer to witness the tests.
2. Leave 2 ft. minimum, 3 ft. maximum length for each conductor up to the splice in ground boxes. Leave 3 ft. minimum, 4 ft. maximum length of conductor in ground boxes when pulled through with no splice. Leave 1 ft. minimum, 1.5 ft. maximum length of conductor at enclosures, weatherheads and pole bases.
3. Make splices only in junction boxes, ground boxes, pole bases, or electrical enclosures and use only listed compression or screw type pressure connectors, terminal blocks, or split bolt connectors. Insulate splices with heavy wall heat shrink tubing or gel-filled insulating splice covers to provide a watertight splice. Overlap conductor insulation with heat shrink tubing a minimum of 2 in. past both sides of the splice. Where heat shrink tubing may not shrink sufficiently to provide a watertight seal around the individual conductors, prior to heating the tubing, increase the diameter of the conductor insulation using hot melt adhesive tape to provide a watertight seal between the individual conductors and the heat shrink tubing. Ensure the tape extends past the heat shrink tubing. Use hot melt adhesive tape to fill the gap and seal the ends of heat shrink tubing. Heat shrink tubing that appears to have been burned, or overheated, is considered defective and must be replaced.
4. Size and install gel-filled insulating splice covers according to manufacturer's specifications when used in place of heat shrink tubing.
5. Wire nuts with factory applied waterproof sealant may be used for 8 AWG or smaller conductors in above ground junction boxes, but not in pole bases or ground boxes. Install wire nuts in an upright position to prevent the accumulation of water.
6. Support conductors in illumination poles with a J-hook at the top of the pole.
7. When terminating conductors, remove the insulation and jacketing material without nicking the individual strands of the conductor. Conductors with nicked individual conductor strands or removed strands will be considered damaged.
8. Replace conductors and cables that are damaged beyond repair or that fail an insulation resistance test at no additional cost to the department.
9. Do not repair damaged conductors with duct tape, electrical tape, or wire nuts. Use only approved splicing methods.
10. Do not terminate more than one conductor under a single connector, unless the connector is rated for multiple conductors. Do not exceed the pressure connector's listing for maximum number and size of conductors allowed.
11. Install breakaway connectors on conductors bid under Item 620 whenever those conductors pass through a breakaway support device. Follow manufacturer's instructions when terminating conductors to breakaway connectors. Properly torque threaded connections. Proper terminations are critical to the safe operation of breakaway devices. Trim waterproofing boots on breakaway connectors to fit snugly around the conductor to ensure waterproof connection. Only one conductor may enter a single opening in a boot. Provide waterproof boots with the correct number of openings. Leave unused openings factory sealed. Use prequalified breakaway connectors as shown on the MPL.

12. Provide and install a separate stranded equipment grounding conductor (EGC) in all conduits that contain circuit wiring of 50 volts or more. Unless shown elsewhere, size the EGC to be the same size as the largest current carrying conductor contained in the conduit. Ensure all EGCs are bonded together at every accessible location. For traffic signal installations, provide a minimum size 8 AWG EGC. The EGC is paid for under Item 620.

C. TEMPORARY WIRING

1. Install temporary conductors and electrical equipment in accordance with the NEC article "Temporary Installations" and Department standard sheets.
2. Provide a ground fault circuit interrupter (GFCI) for power outlets for portable electrical equipment, power tools, ice machines, ice storage bins and refrigerators located outdoors at grade. GFCI may be any one of the following: molded cord and plug set, receptacle, or circuit breaker type.
3. Use listed wire nuts with factory applied sealant for temporary wiring where approved.
4. Enclose conductor splices within a listed enclosure or ground box, or ensure the splices are more than 10 ft. above grade vertically and more than 5 ft. horizontally from any metal structure. Where installing temporary conductors in areas subject to vehicle traffic or mobile construction equipment, ensure the vertical clearance to ground is at least 18 ft. when measured at the lowest point. Ground messenger wires that support power conductors in conformance with the NEC.
5. Protect and when necessary repair any existing electrical conduits uncovered during the construction process in a timely manner and in conformance with the NEC.

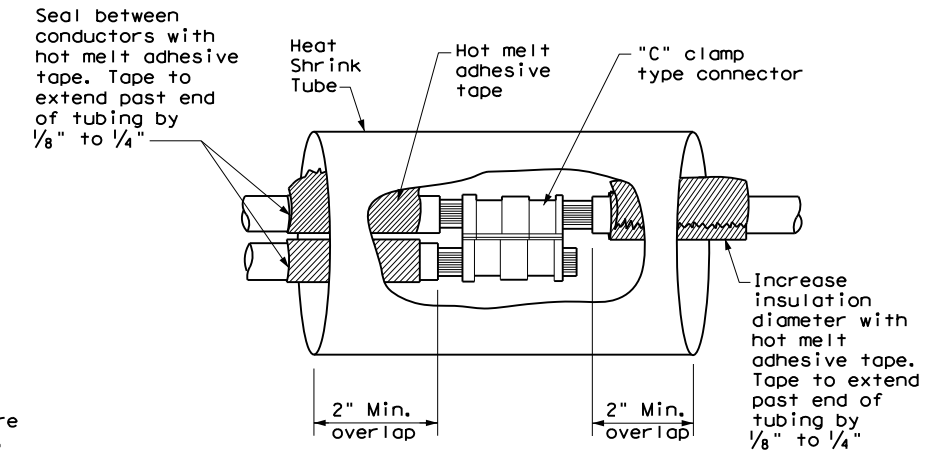

**SPLICE OPTION 1
Compression Type**

GROUND RODS & GROUNDING ELECTRODES

A. MATERIAL INFORMATION

1. Provide and install a grounding electrode at electrical services. Provide ground rods according to DMS 11040 and the plans. Larger diameter or longer length rods may be called for in some specific locations, see the individual plans sheets. Concrete encased grounding electrodes may be called for in specific locations including electrical service, see individual plan sheets.

B. CONSTRUCTION METHODS

1. Furnish auxiliary ground rods for lightning protection and install in soil, concrete, or both, as called for in the plans. For ground rods installed in concrete, ensure the connection of the conductor to the ground rod is readily accessible for inspection or repairs. For ground rods installed in soil, ensure that the upper end is between 2 to 4 in. below finished grade.
2. Do not place ground rods in the same drilled hole as a timber pole.
3. Install ground rods so the imprinted part number is at the upper end of the rod.
4. Remove all non-conductive coatings such as concrete splatter from the rod at the clamp location.
5. Route all conductors as short and straight as possible for connection to lightning protection ground rods. When a bend is required, ensure a minimum radius bend of four inches for these conductors.
6. Unless otherwise called for in the plans, protect grounding electrode conductors with non-metallic conduit. When protecting grounding electrode conductors with metal conduit, provide and install a grounding type bushing and properly sized bonding jumper on each end of the metal conduit.
7. Written authorization is required before installing a ground rod in a horizontal trench for rocky soil or a solid rock bottom.

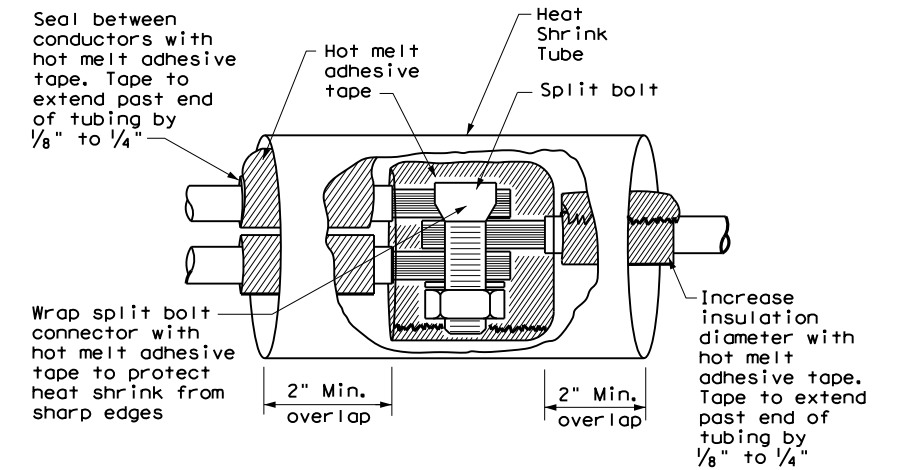

**SPLICE OPTION 2
Split Bolt Type**

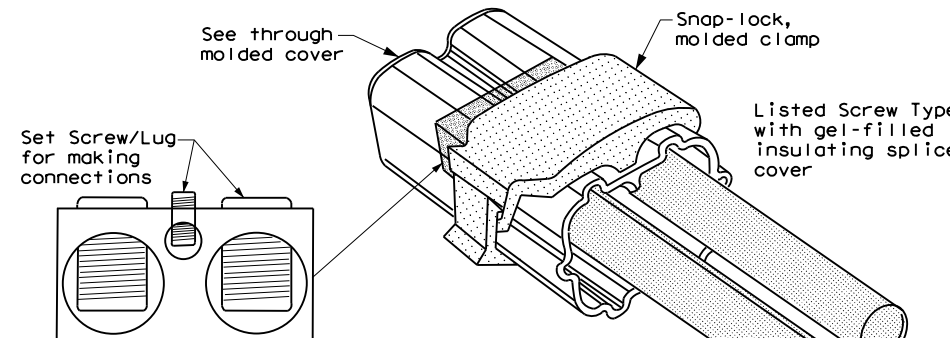

**SPLICE OPTION 3
Listed Screw Type**

		Texas Department of Transportation		Traffic Operations Division Standard	
<h1>ELECTRICAL DETAILS CONDUCTORS</h1>					
<h2>ED(3) - 14</h2>					
FILE:	ed3-14.dgn	DW:	TxDOT	CK:	TxDOT
© TxDOT	October 2014	CONT:	0010	SECT:	08
REVISIONS		JOB:	060		US 67
		DIST:	COUNTY:	SHEET NO.	
		ATL	MORRIS	84	

DATE: 1/11/2024 3:13:37 PM
 FILE: I:\engdata\Traffic\ED(3)-14.dgn
 PROJECT: LIGHTING PROJECTS
 DRAWING: ED(3)-14
 DRAWN BY: JAMIE JOBS
 CHECKED BY: JAMIE JOBS
 DISCLAIMER: The use of this standard is governed by the "Texas Engineering Practice Act". No warranty of any kind is made by TxDOT for any purpose whatsoever. TxDOT assumes no responsibility for the conversion of units or for any errors or omissions in this drawing.

ELECTRICAL SERVICES NOTES

- Provide new materials. Ensure installation and materials comply with the applicable provisions of the National Electrical Code (NEC) and National Electrical Manufacturers Association (NEMA) standards. Ensure material is Underwriters Laboratories (UL) listed. Provide and install electrical service conduits, conductors, disconnects, contactors, circuit breaker panels, and branch circuit breakers as shown on the Electrical Service Data chart in the plans. Faulty fabrication or poor workmanship in material, equipment, or installation is justification for rejection. Where manufacturers provide warranties and guarantees as a customary trade practice, furnish these to the State.
- Provide electrical services in accordance with Electrical Details standard sheets, Departmental Material Specification (DMS) 11080 "Electrical Services," DMS 11081 "Electrical Services-Type A," DMS 11082 "Electrical Services-Type C," DMS 11083 "Electrical Services-Type D," DMS 11084 "Electrical Services-Type T," DMS 11085 "Electrical Services-Pedestal (PS)", and Item 628 "Electrical Services" of the Standard Specifications. Provide electrical service types A, C, and D, as listed on the Material Producers List (MPL) on the Department web site under "Roadway Illumination and Electrical Supplies," Item 628. Provide other service types as detailed on the plans.
- Provide all work, materials, services, and any incidentals needed to install a complete electrical service as specified in the plans.
- Coordinate with the Engineer and the utility provider for metering and compliance with utility requirements. Primary line extensions, connection charges, meter charges, and other charges by the utility company to provide power to the location are paid for in accordance with Item 628. Get approval for the costs associated with these charges prior to engaging the utility company to do the work. Consult with the utility provider to determine costs and requirements, and coordinate the work as approved.
- The enclosure manufacturer will provide Master Lock Type 2 with brass tumblers keyed #2195 for all custom electrical enclosures. Installing Contractor is to provide Master Lock #2195 Type 2 with brass tumblers for "off the shelf" enclosures. Master Lock #2195 keys and locks become property of the State. Unless otherwise approved, do not energize electrical service equipment until locks are installed.
- Enclosures with external disconnects that de-energize all equipment inside the enclosure do not need a dead front trim. Protect incoming line terminations from incidental contact as required by the NEC.
- When galvanized is specified for nuts, screws, bolts or miscellaneous hardware, stainless steel may be used.
- Provide wiring and electrical components rated for 75°C. Provide red, black, and white colored XHHW service entrance conductors of minimum size 6 American Wire Gauge (AWG). Identify size 6 AWG conductors by continuous color jacket. Identify electrical conductors sized 4 AWG and larger by continuous color jacket or by colored tape. Mark at least 6 inches of the conductor's insulation with half laps of colored tape, when identifying conductors. Ensure each service entrance conductor exits through a separately bushed non-metallic opening in the weatherhead. The lengths of the conductors outside the weatherhead are to be 12 inches minimum, 18 inches maximum, or as required by utility.
- All electrical service conduit and conductors attached to the electrical service including the riser or the elbow below ground are subsidiary to the electrical service. For an underground utility feed, all service conduit and conductors after the elbow, including service conduit and conductors for the utility pole riser when furnished by the Contractor, will be paid for separately.
- Provide rigid metal conduit (RMC) for all conduits on service, except for the 1/2 in. PVC conduit containing the electrical service grounding electrode conductor. Size the service entrance conduit as shown in the plans. Ensure conduit for branch circuit entry to enclosure is the same size as that shown on the layout sheets for branch circuit conduit. Extend all rigid metal conduits a minimum of 6 inches underground and then couple to the type and schedule of the conduit shown on the layout for that particular branch circuit. Install a grounding bushing on the RMC where it terminates in the service enclosure.
- Use of liquidtight flexible metal conduit (LFMC) is allowed between the meter and service enclosure when they are mounted 90 to 180 degrees to each other. Size the LFMC the same size as service entrance conduit. LFMC must not exceed 3 feet in length. Strap LFMC within 1 foot of each end. LFMC less than 12 inches in length need not be strapped. Each end of LFMC must have a grounding bushing or be terminated with a grounding fitting. The LFMC must contain a grounded (neutral) conductor. Ensure any bend in LFMC never exceeds 180 degrees. A pull test is required on all installed conductors, with at least six inches of free conductor movement demonstrated to the satisfaction of the Engineer.
- Ensure all mounting hardware and installation details of services conform to utility company specifications.
- For all electrical service enclosures listed under Item 628 on the MPL, the UL 508 enclosure manufacturers will prepare and submit a schematic drawing unique to each service. Before shipment to the job site, place the applicable laminated schematic drawings and the laminated plan sheet showing the electrical service data chart used to build the enclosure in the enclosure's data pocket. The installing contractor will copy and laminate the actual project plan sheets detailing all equipment and branch circuits supplied by that service. The laminated plan sheets are to be placed in the service enclosure's document pocket. Reduce 11 in. x 17 in. plan sheets to 8 1/2 in. x 11 in. before laminating. If the installation differs from the plan sheets, the installing contractor is to redline plan sheets before laminating.
- When providing an "Off The Shelf" Type D or Type T service, provide laminated plan sheets detailing equipment and branch circuits supplied by that service. Reduce 11 in. x 17 in. plan sheets to 8 1/2 in. x 11 in. before laminating. Deliver these drawings before completion of the work to the Engineer, instead of placing in enclosure that has no door pocket.
- Do not install conduit in the back wall of a service enclosure where it would penetrate the equipment mounting panel inside the enclosure. Provide grounding bushings on all metal conduits, and terminate bonding jumpers to grounding bus. Grounding bushings are not required when the end of the metal conduit is fitted with a conduit sealing hub or threaded boss, such as a meter base hub.

SERVICE ASSEMBLY ENCLOSURE

- Provide threaded hub for all conduit entries into the top of enclosure.
- Type galvanized steel (GS) enclosures may be used for Type C panelboards and for Type D and T services that do not use an enclosure mounted photoceII or lighting contactor. Provide GS enclosures in accordance with DMS 11080, 11082, 11083, and 11084.
- Provide aluminum (AL) and stainless steel (SS) enclosures for Types A, C, and D in accordance with DMS 11080, 11081, 11082, 11083, and 11084. Do not paint stainless steel.
- Provide pedestal service (PS) enclosures in accordance with ED(9) and DMS 11080 and 11085. Do not provide GS pedestal services. If GS is shown in the PS descriptive code, provide an AL enclosure.

MAIN DISCONNECT & BRANCH CIRCUIT BREAKERS

- Field drill flange-mounted remote operator handle if needed, to ensure handle is lockable in both the "On" and "Off" positions.
- When the utility company provides a transformer larger than 50 KVA, verify that the available fault current is less than the circuit breaker's ampere interrupting capacity (AIC) rating and provide documentation from the electric utility provider to the Engineer.

PHOTOELECTRIC CONTROL

- Provide photocell as listed on the MPL. Move, adjust, or shield the photocell from stray or ambient night time light to ensure proper operation. Mount photocell facing north when practical. Mount top of pole photocells as shown on Top Mounted Photocell Detail.

* ELECTRICAL SERVICE DATA												
Elec. Service ID	Plan Sheet Number	Electrical Service Description	Service Conduit *xSize	Service Conductors No./Size	Safety Switch Amps	Main Ckt. Bkr. Pole/Amps	Two-Pole Contractor Amps	Panelbd/ Loadcenter Amp Rating	Branch Circuit ID	Branch Ckt. Bkr. Pole/Amps	Branch Circuit Amps	KVA Load
SB 183	289	ELC SRV TY A 240/480 100(SS)AL(E)SF(U)	2"	3/#2	100	2P/100	100	N/A	Lighting NB	2P/40	26	28.1
									Lighting SB	2P/40	25	
									Underpass	1P/20	15	
NB Access	30	ELC SRV TY D 120/240 060(NS)SS(E)TS(O)	1 1/4"	3/#6	N/A	2P/60		100	Sig. Controller	1P/30	23	5.3
							30		Luminares	2P/20	9	
									CCTV	1P/20	3	
2nd & Main	58	ELC SRV TY T 120/240 000(NS)GS(N)SP(O)	1 1/4"	3/#6	N/A	N/A	N/A	70	Flashing Beacon 1	1P/20	4	1.0
									Flashing Beacon 2	1P/20	4	

* Example only, not for construction. All new electrical services must have electrical service data chart specific to that service as shown in the plans.
 ** Verify service conduit size with utility. Size may change due to utility meter requirements. Ensure conduit size meets the National Electrical Code.

EXPLANATION OF ELECTRICAL SERVICE DESCRIPTIVE CODE

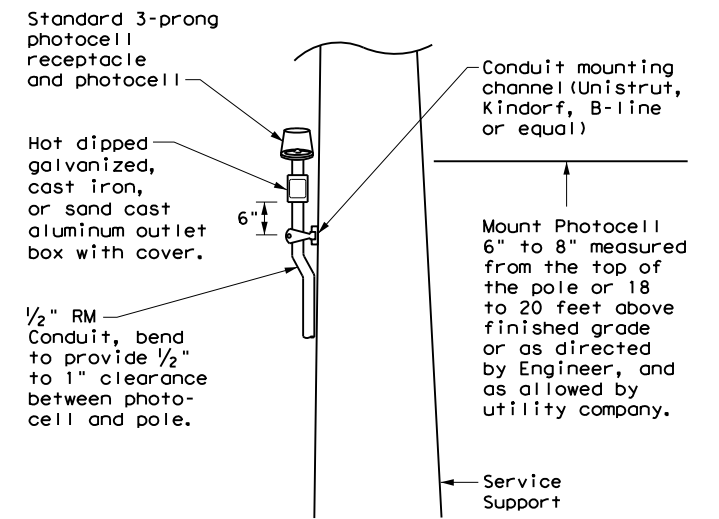
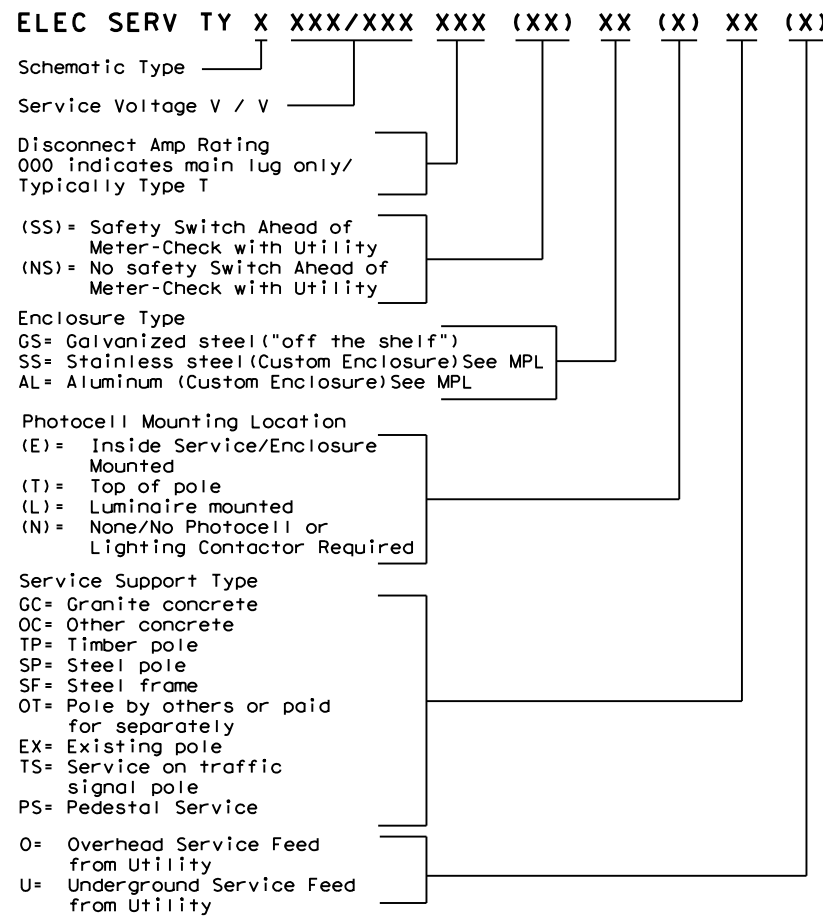

TOP MOUNTED PHOTOCELL

Install conduit strap maximum 3 feet from box. 5 foot maximum spacing between straps supporting conduit.

Texas Department of Transportation Traffic Operations Division Standard

ELECTRICAL DETAILS SERVICE NOTES & DATA

ED(5) - 14

FILE: ed5-14.dgn	DWG: TxDOT	CHK: TxDOT	DWG: TxDOT	CHK: TxDOT
© TxDOT October 2014	CONT	SECT	JOB	HIGHWAY
REVISIONS	0010	08	060	US 67
	DIST	COUNTY	SHEET NO.	
	ATL	MORRIS	86	

DATE: 1/11/2024 3:14:39 PM
 FILE: I:\engdata\Traffic\JGMD\192515 Jamie\JOBS\LIGHTING PROJECTS\Lighting Projects\ED(5)-14.dgn
 The use of this standard is governed by the "Texas Engineering Practice Act". No warranty of any kind is made by TxDOT for any purpose whatsoever. TxDOT assumes no responsibility for the conversion of units or for any errors or omissions in this document.

DISCLAIMER: The use of this standard is governed by the "Texas Engineering Practice Act". No warranty of any kind is made by TxDOT for any purpose whatsoever. TxDOT assumes no responsibility for the conversion of any information from a previous edition of this standard to a later edition.

DATE: 1/11/2024 3:15:22 PM
 FILE: T:\Engdat\Traffic\DGND\192515_Jamie\JOBS\LIGHTING PROJECTS\Lighting of 012024\20240111\ED(6)-14.dgn

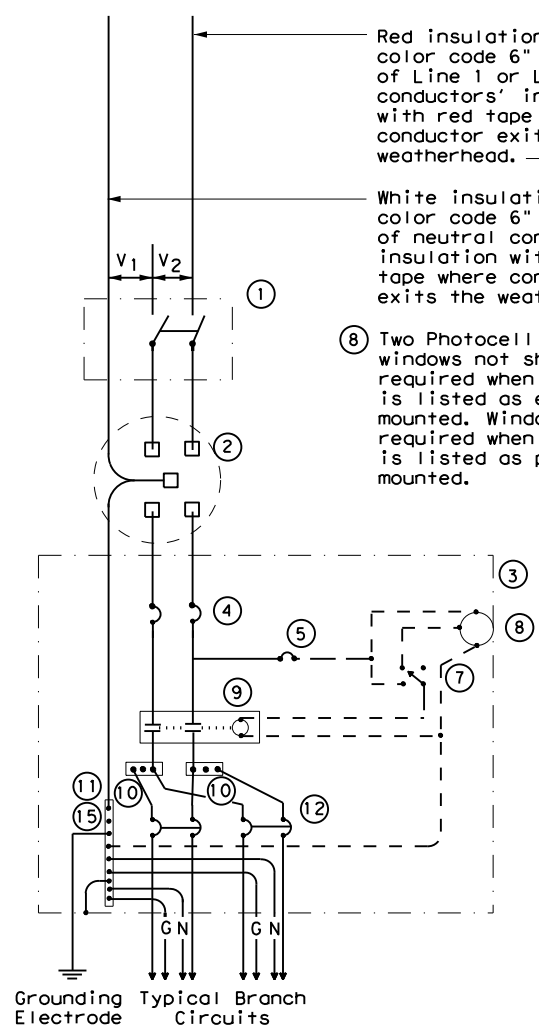

**SCHEMATIC TYPE A
THREE WIRE**

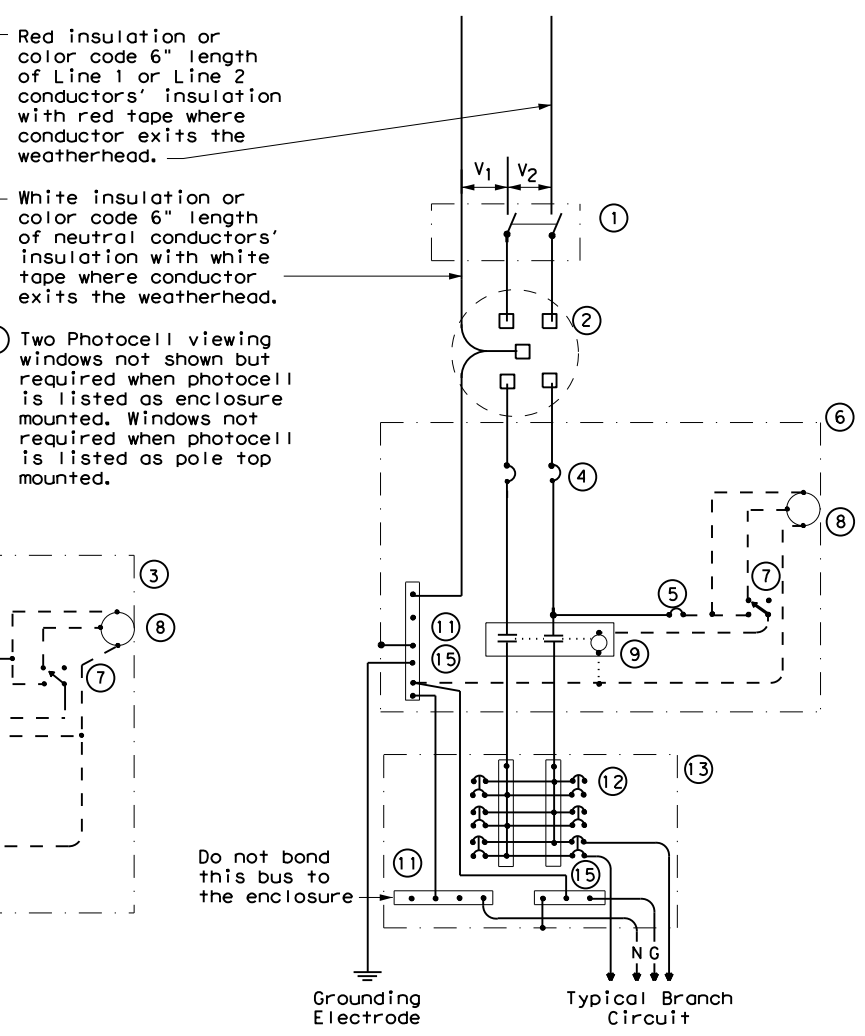

**SCHEMATIC TYPE C
THREE WIRE**

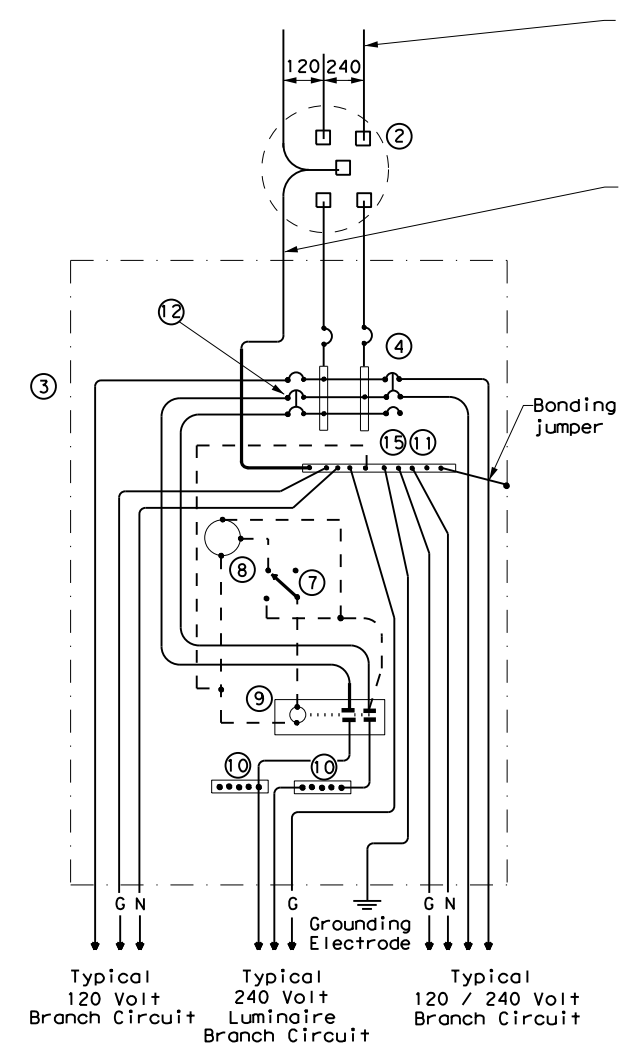

**SCHEMATIC TYPE D - CUSTOM
120/240 VOLTS - THREE WIRE**

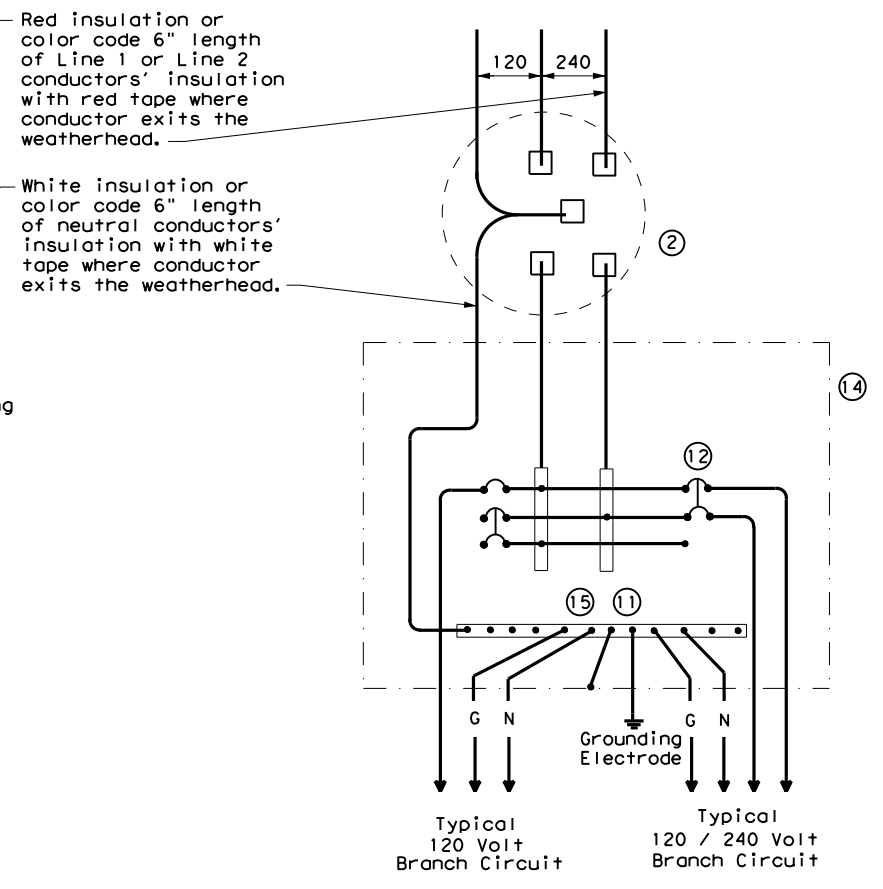

**SCHEMATIC TYPE T
120/240 VOLTS - THREE WIRE**
 Galvanized steel - "Buy Off The Shelf" only. When required install photocell top of the pole or on luminaire only, no lighting contractor will be installed.

WIRING LEGEND	
————	Power Wiring
- - - -	Control Wiring
—N—	Neutral Conductor
—G—	Equipment grounding conductor-always required

SCHEMATIC LEGEND	
1	Safety Switch (when required)
2	Meter (when required-verify with electric utility provider)
3	Service Assembly Enclosure
4	Main Disconnect Breaker (See Electrical Service Data)
5	Circuit Breaker, 15 Amp (Control Circuit)
6	Auxiliary Enclosure
7	Control Station ("H-O-A" Switch)
8	Photo Electric Control (enclosure-mounted shown)
9	Lighting Contactor
10	Power Distribution Terminal Blocks
11	Neutral Bus
12	Branch Circuit Breaker (See Electrical Service Data)
13	Separate Circuit Breaker Panelboard
14	Load Center
15	Ground Bus

				Traffic Operations Division Standard	
ELECTRICAL DETAILS SERVICE ENCLOSURE AND NOTES					
ED(6) - 14					
FILE:	ed6-14.dgn	DN:	TxDOT	CK:	TxDOT
© TxDOT	October 2014	CONT:	0010	SECT:	08
REVISIONS		JOB:	060	HIGHWAY:	US 67
DIST:	ATL	COUNTY:	MORRIS	SHEET NO.:	87

DATE: 1/11/2024 3:15:47 PM
 FILE: T:\engdata\Traffic\DGND\192515_Jamie\JOBS\LIGHTING PROJECTS\Lighting Project\ED(7)-14.dgn
 The use of this standard is governed by the "Texas Engineering Practice Act". No warranty of any kind is made by TxDOT for any purpose whatsoever. TxDOT assumes no responsibility for the conversion of units or for the accuracy of the information contained herein.

SUPPORT TYPE STEEL POLE (SP) AND STEEL FRAME (SF)

1. Provide steel pole and steel frame supports as per TxDOT Departmental Material Specification (DMS) 11080 "Electrical Services." Mount all equipment and conduit on 12 gauge galvanized steel or stainless steel channel strut, 1 1/2 in. or 1 3/8 in. wide by 1 in. up to 3 3/4 in. deep Unistrut, Kindorf, B-line or equal. Bolt or weld all channel and hardware to vertical members as approved. Do not stack channel. File smooth and paint field cut ends of all channel with zinc-rich paint before installing.
2. Provide poles for overhead service with an eyebolt or similar fitting for attachment of the service drop to the pole in conformance with the electric utility provider's specifications.
3. Provide and install galvanized 3/4 in. x 18 in. x 4 in. (dia. x length x hook length) anchor bolts for underground service supports. Provide and install galvanized 3/4 in. x 56 in. x 4 in. anchor bolts for overhead service supports. Ensure anchor bolts have 3 in. of thread, with 3 1/4 in. to 3 1/2 in. of the exposed anchor bolt projecting above finished foundation. Provide and install leveling nuts for all anchor bolts.
4. Bond one of the anchor bolts to the rebar cage with 6 AWG bare stranded copper conductor. Use listed mechanical connectors rated for embedment in concrete. See Inset B.
5. Furnish and install rigid metallic ellis in all steel pole and steel frame foundations for all conduits entering the service from underground.
6. Use class C concrete for foundations. Ensure reinforcing steel is Grade 60 with 3" of unobstructed concrete cover.
7. Drill and tap steel poles and frames for 1/2 in. X 13 UNC tank ground fitting. For steel pole service supports, provide and install tank ground fitting 4 in. to 6 in. below electrical service enclosure. Provide properly sized hole through the bottom of the enclosure for the service grounding electrode conductor. Ensure electrical service grounding electrode conductor is as short and straight as possible from the enclosure to the tank ground fitting. For steel frame service supports, provide and install tank ground fitting on steel frame post. Install service grounding electrode conductor in a non-metallic conduit or tubing from the enclosure to the steel frame post. Connect electrical service grounding electrode conductor to the tank ground fitting. See steel frame and steel pole details and Inset A for more information. Size service entrance conduit and branch circuit conduit as shown in the plans. For underground conduit runs from the electrical service, extend RMC from the service enclosure to an RMC elbow, and then connect the schedule type and size of conduit shown in the plans. Provide and install grounding bushings where RMC terminates in the enclosure. Grounding bushings are not required when RMC is fitted into a sealing hub or threaded boss.
8. If Steel pole or frame is painted, bond each separate painted piece with a bonding jumper attached to a tapped hole.
9. Provide 1/4" - 20 machine screws for bonding. Do not use sheet metal screws. Remove all non-conductive material at contact points. Terminate bonding jumpers with listed devices. Install minimum size 6 AWG stranded copper bonding jumpers. Make up all threaded bonding connections wrench tight.
10. Avoid contact of the service drop and service entrance conductors with the metal pole to prevent abrasion of the insulated conductors.
11. Shop drawings are not required for service support structure unless specifically stated elsewhere or directed by the Engineer.

White insulation or color code 6" of neutral conductor's insulation with white tape where conductor exits weatherhead.

Red insulation or color code 6" length of Line 1 or Line 2 conductor's insulation with red tape where conductor exits the weatherhead. Conductor slack length, 12" min., 18" max.

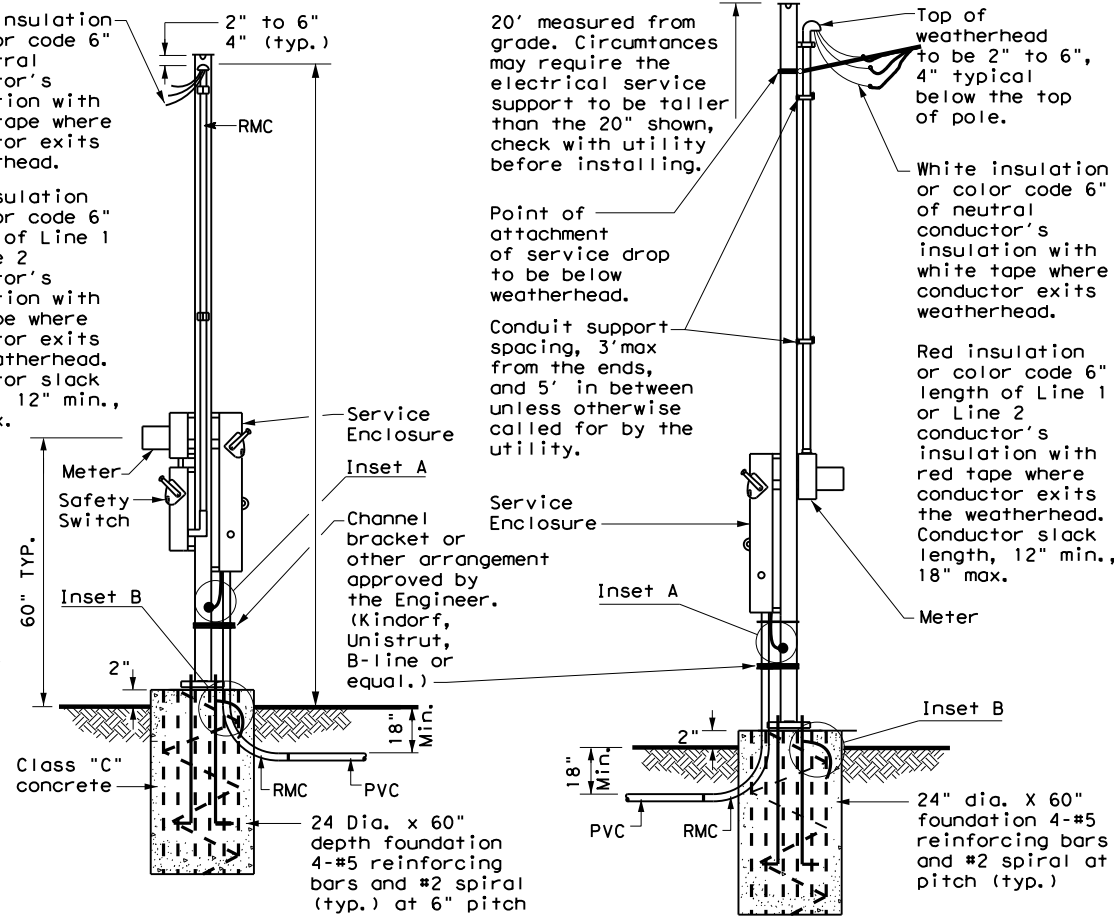

WITH SAFETY SWITCH
WITHOUT SAFETY SWITCH
SERVICE SUPPORT TYPE SP (O) - OVERHEAD SERVICE

Drill, tap, and thread 1/2" X 13 UNC. Install tank ground fitting, connect electrical service grounding electrode conductor. See Note 7.

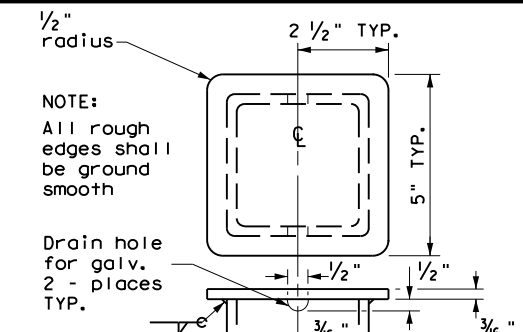
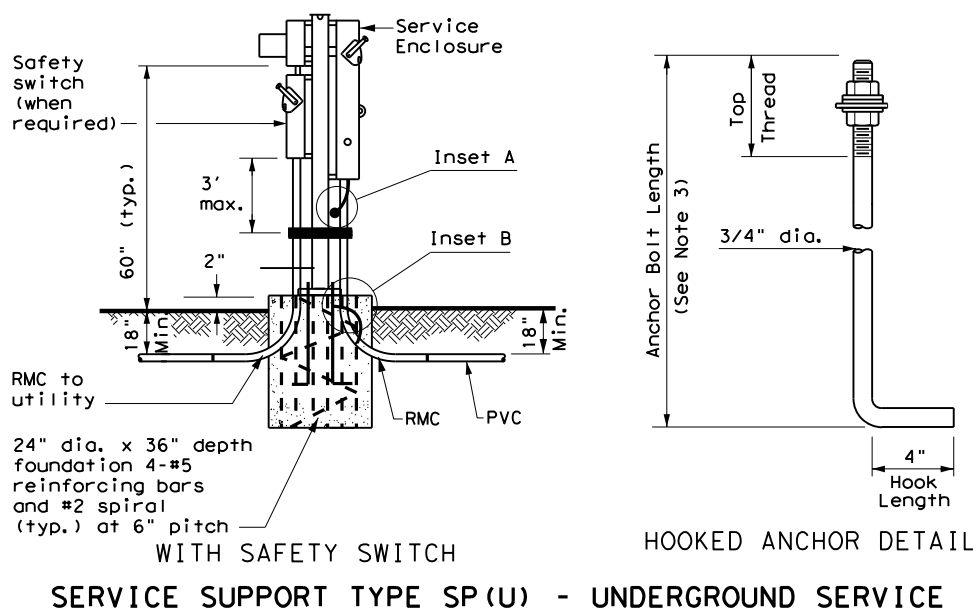
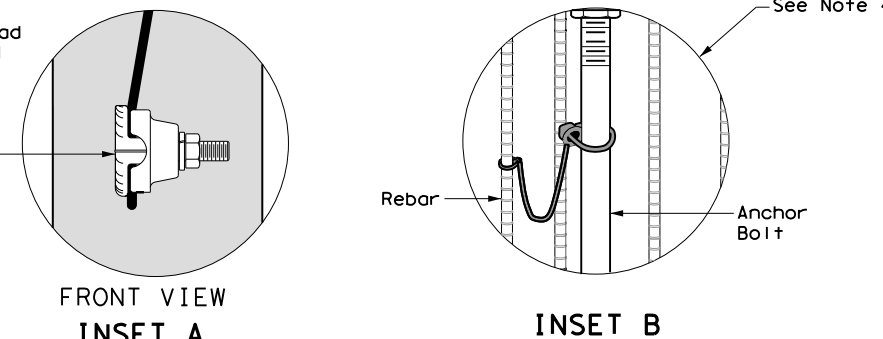

POLE TOP PLATE

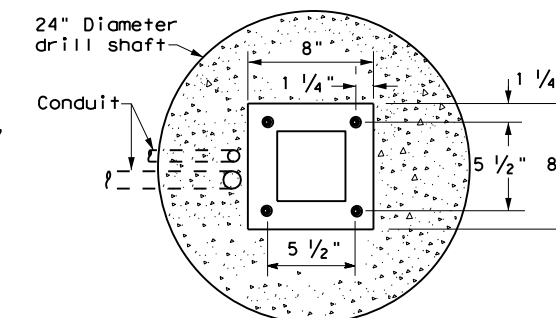

BASE PLATE DETAIL

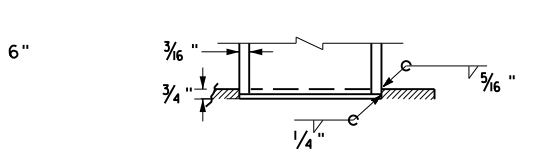

BOTTOM OF POLE

SERVICE SUPPORT TYPE SF & SP

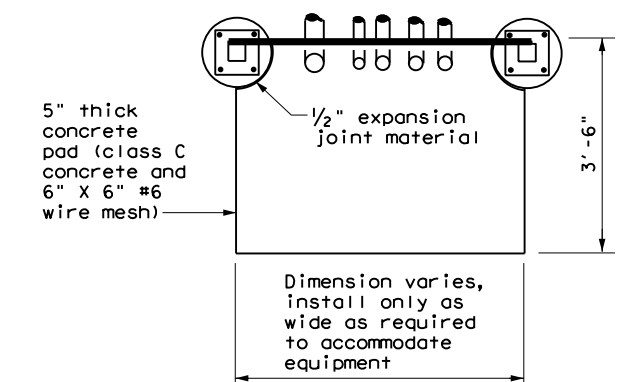

TOP VIEW

SERVICE SUPPORT TYPE SF (O) & SF (U)

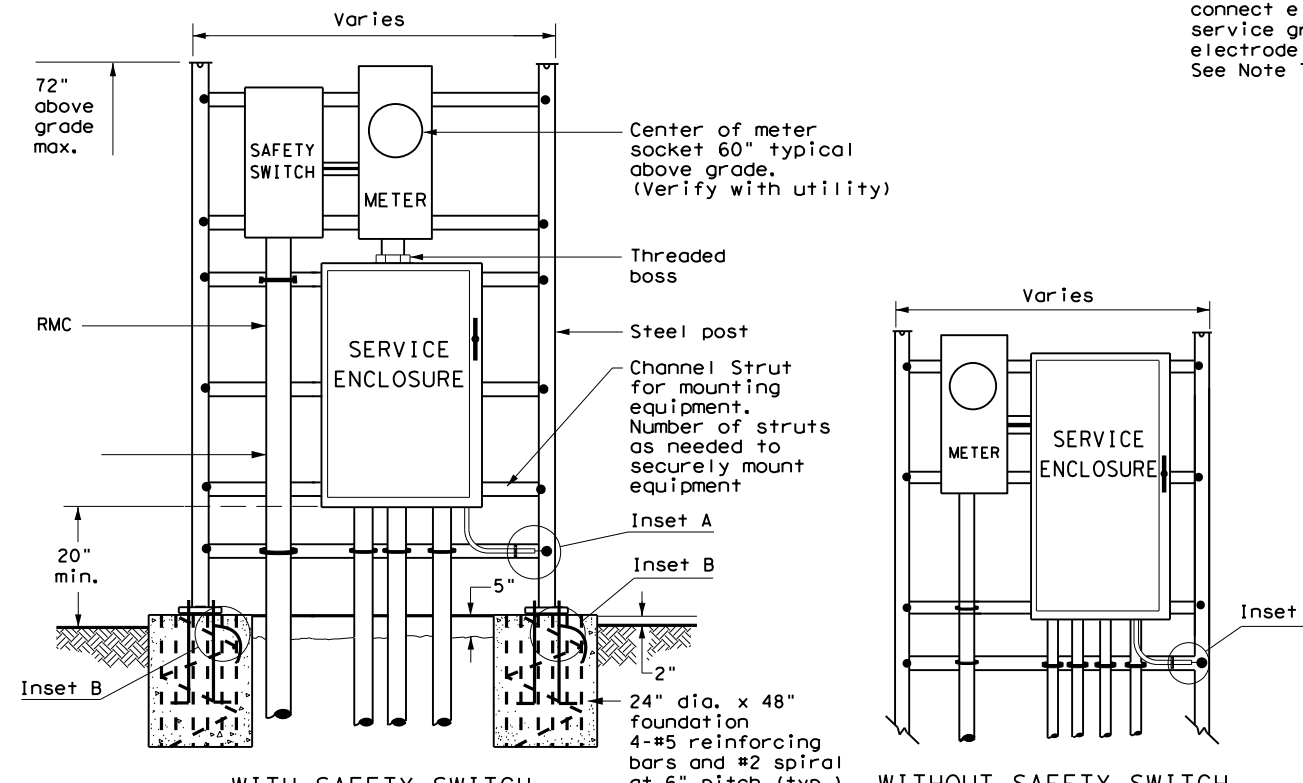

WITH SAFETY SWITCH FRONT VIEW
WITHOUT SAFETY SWITCH
SERVICE SUPPORT TYPE SF (U) - UNDERGROUND SERVICE

		Traffic Operations Division Standard	
ELECTRICAL DETAILS SERVICE SUPPORT TYPES SF & SP ED(7)-14			
FILE: ed7-14.dgn	DW: TxDOT	CK: TxDOT	DW: TxDOT
© TxDOT October 2014	CON: 0010	SECT: 08	JOB: 060
REVISIONS			US 67
	DIST: ATL	COUNTY: MORRIS	SHEET NO. 88

DISCLAIMER: The use of this standard is governed by the "Texas Engineering Practice Act". No warranty of any kind is made by TxDOT for any purpose whatsoever. TxDOT assumes no responsibility for the conversion of units or for any errors or omissions in this drawing. If you have any questions, please contact the project engineer.

DATE: 1/11/2024 3:19:58 PM
 FILE: T:\engdata\Traffic\Lighting\PROJECTS\Lighting\rip-19\rip-19.dgn

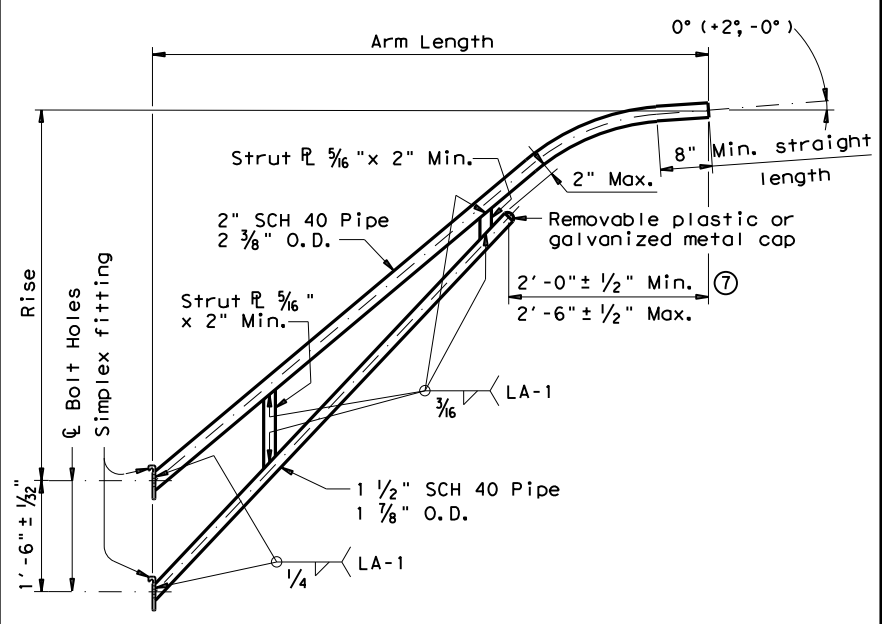

LUMINAIRE ARM

LUMINAIRE ARM DIMENSIONS		
Nominal Arm Length	Arm Length	Rise
4'-0"	3'-6"	2'-6"
6'-0"	5'-6"	5'-6"
8'-0"	7'-6"	5'-6"
10'-0"	9'-6"	5'-6"
12'-0"	11'-6"	5'-6"

ARM ASSEMBLY FABRICATION TOLERANCES TABLE	
DIMENSION	TOLERANCE
Arm Length	±1"
Arm Rise	±1"
Deviation from flat	1/8" in 12"
Spacing between holes	±1/32"

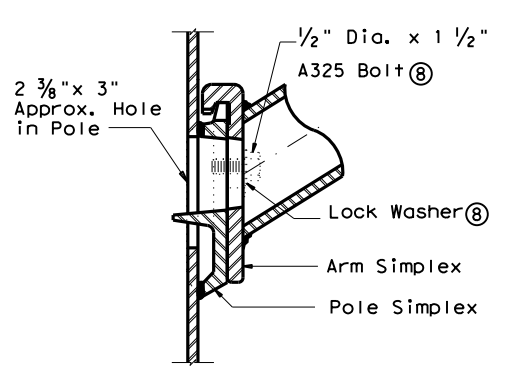

UPPER SIMPLEX FITTING
(Gusset not shown for clarity)

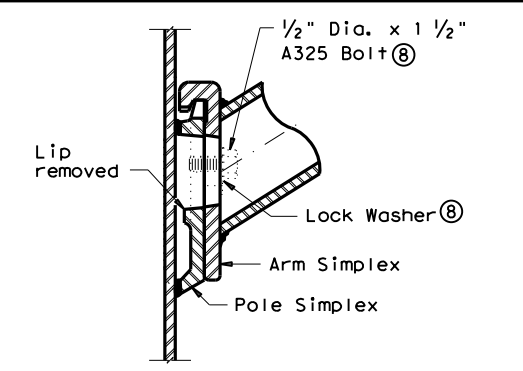

LOWER SIMPLEX FITTING
(Gusset not shown for clarity)

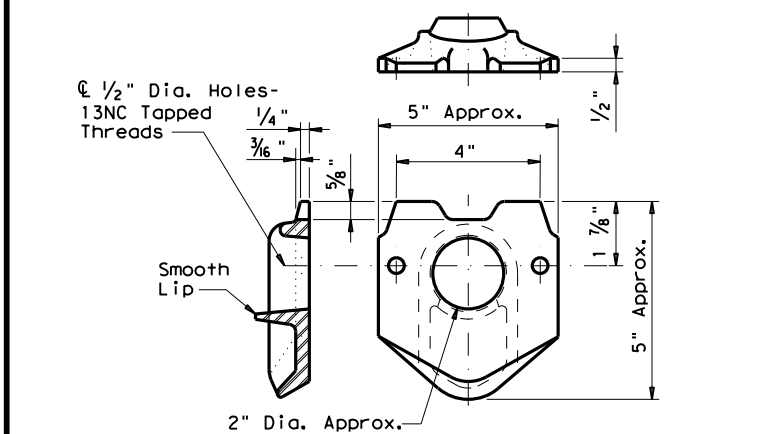

POLE SIMPLEX DETAIL

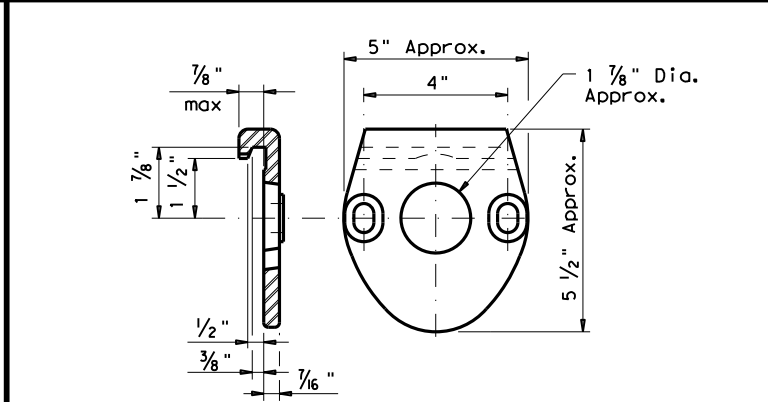

ARM SIMPLEX DETAIL

- NOTES:**
- Any of the materials listed for plates may be used where the drawings do not specify a particular ASTM designation.
 - A576 must be suitable for forging and also meet minimum tensile strength of 65 ksi, minimum yield of 35 ksi, and elongation in 2 inches of 22 percent.
 - A572, A1008 HSLAS-F, and A1011 HSLAS-F materials may have higher yield strengths but shall not have less elongation than the grade indicated.
 - Dimensional limits are given to show acceptable variation in design. All of a Fabricator's production of a particular arm length shall have the same dimensions within specified tolerances.
 - Each pole simplex fitting shall be supplied with 2 bolts and 2 lock washers of the size specified. The bolts and lock washers shall be secured to the pole with the other hardware items called for in the plans.
 - Proposed deviations in arm simplex dimensions or materials must be submitted to the Department for approval.
 - A welded handhole frame is permissible. Maximum of two (2) CJP weld splices is allowed.

MATERIALS	
Pole or Arm Simplex	ASTM A27 Gr 65-35 or Gr 70-36, A148 Gr 80-50, A576 Gr 1021, or A36 (Arm only)
Arm Pipes	ASTM A53 Gr A or B, A500 Gr B, A501, A 1008 HSLAS-F Gr 50, or A1011 HSLAS-F Gr 50
Arm Struts and Gusset Plates	ASTM A36, A572 Gr 50, or A588
Misc.	ASTM designations as noted

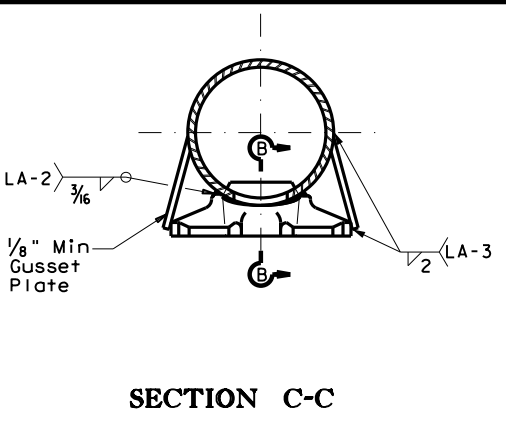
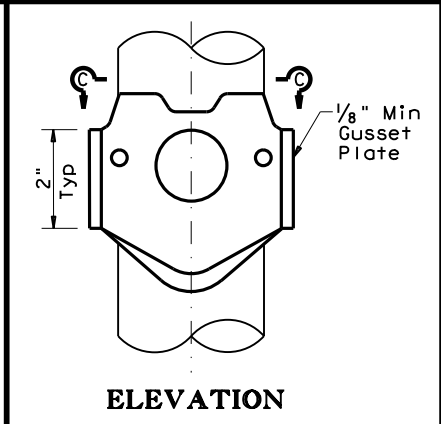
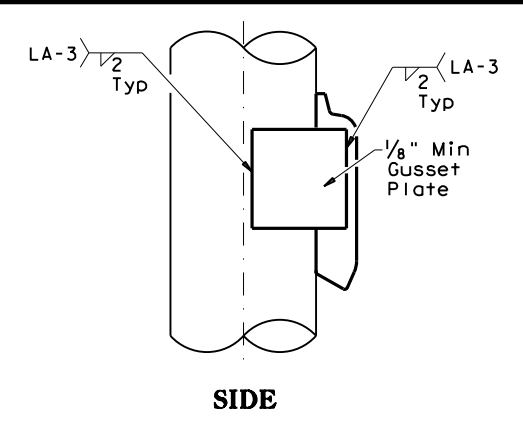

SIMPLEX ATTACHMENT DETAIL

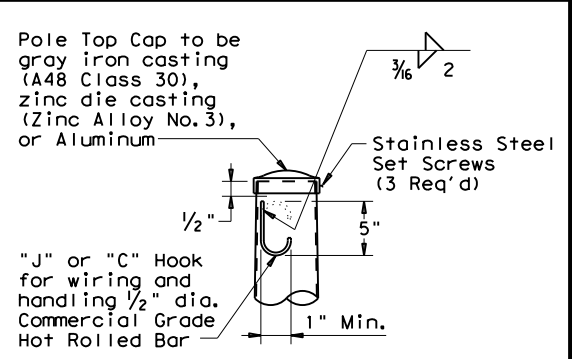

POLE TOP

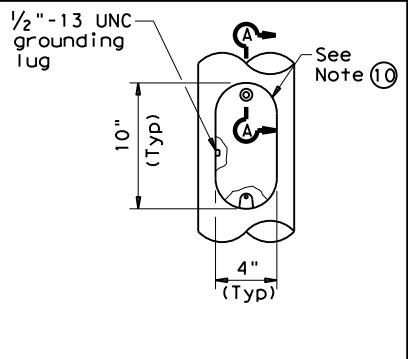

ELEVATION

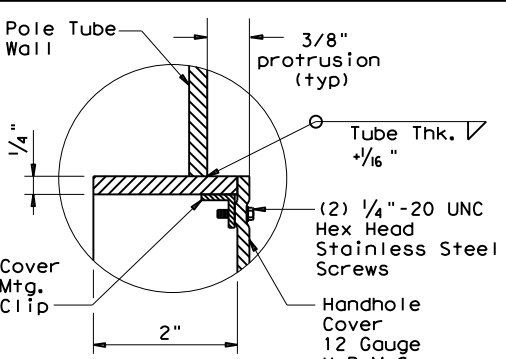

SECTION A-A

HANDHOLE

SHEET 3 OF 4



ROADWAY ILLUMINATION POLES
RIP(3) - 19

FILE: rip-19.dgn	DN:	CK:	DW:	CK:
©TxDOT January 2007	CONT	SECT	JOB	HIGHWAY
REVISIONS	0010	08	060	US 67
7-17	DIST	COUNTY	SHEET NO.	
12-19	ATL	MORRIS	93	

DATE: 1/11/2024 3:20:27 PM
 FILE: I:\eng\dot\Traffic\DG\N\192515_Jamie\JOBS\LIGHTING PROJECTS\Lighting of 01-15-2023\192515-01-15-2023.dwg
 The use of this standard is governed by the "Texas Engineering Practice Act". No warranty of any kind is made by TxDOT for any purpose whatsoever. TxDOT assumes no responsibility for the conversion of units or for the accuracy of the information provided.

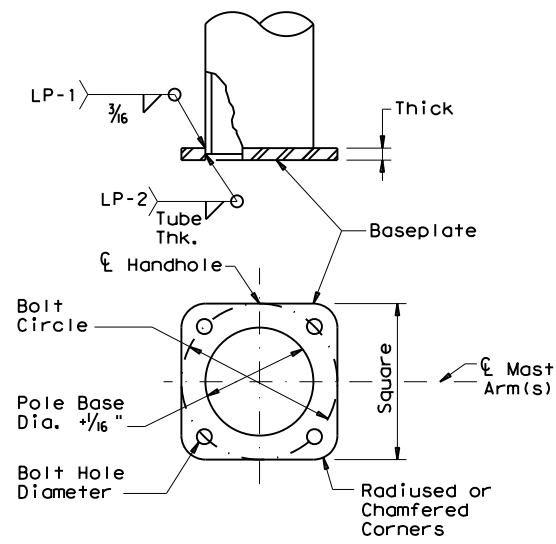

SHOE BASE BASEPLATE

SHOE BASE BASEPLATE TABLE				
MOUNTING HEIGHTS (nominal)	BOLT CIRCLE	SQUARE	THICK	BOLT HOLE DIAMETER
20' - 39'	13"	13"	1 1/4"	1 1/4"
40'	15"	15"	1 1/4"	1 1/2"
50'	15"	15"	1 1/2"	1 1/2"

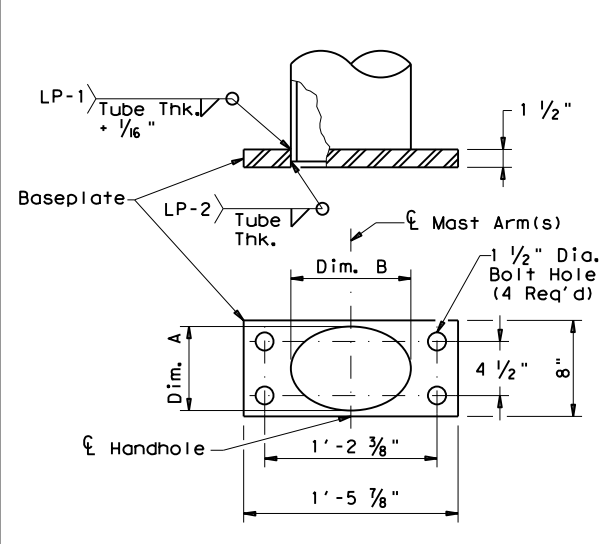

CONCRETE TRAFFIC BARRIER BASE BASEPLATE

CONCRETE TRAFFIC BARRIER BASE BASEPLATE TABLE			
MOUNTING HEIGHTS (nominal)	POLE DIA. (1)	DIM. A	DIM. B
28' - 38'	9"	7" ± 1/4"	10" ± 1/4"
48'	10 1/2"	7" ± 1/4"	13" ± 1/4"

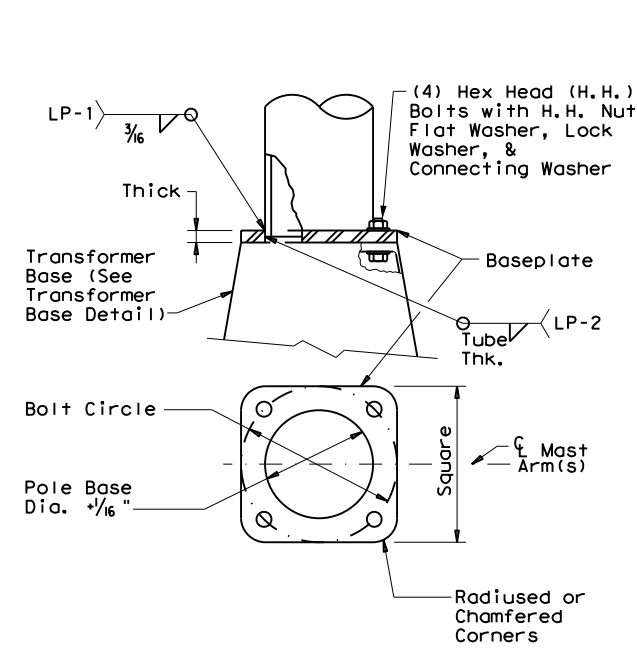

TRANSFORMER BASE BASEPLATE

TRANSFORMER BASE BASEPLATE TABLE						
MOUNTING HEIGHTS (nominal)	BOLT CIRCLE	SQUARE	THICK	CONNECTING BOLT DIA.	BOLT HOLE DIAMETER	TRANSFORMER BASE TYPE
20' - 39'	13"	13"	1 1/4"	1"	1 1/4"	A
40'	15"	15"	1 1/4"	1 1/4"	1 1/2"	B
50'	15"	15"	1 1/2"	1 1/4"	1 1/2"	B

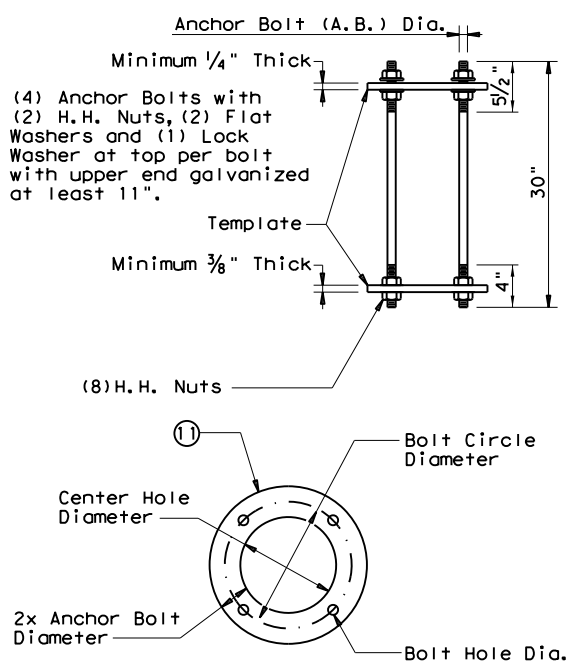

SHOE BASE ANCHOR BOLT ASSEMBLY

SHOE BASE ANCHOR BOLT ASSEMBLY TABLE				
MOUNTING HEIGHTS (nominal)	A.B. Dia.	BOLT CIRCLE DIAMETER	CTR. HOLE DIAMETER	BOLT HOLE DIAMETER
20' - 39'	1"	13"	11"	1 1/16"
40' - 50'	1 1/4"	15"	12 1/2"	1 5/16"

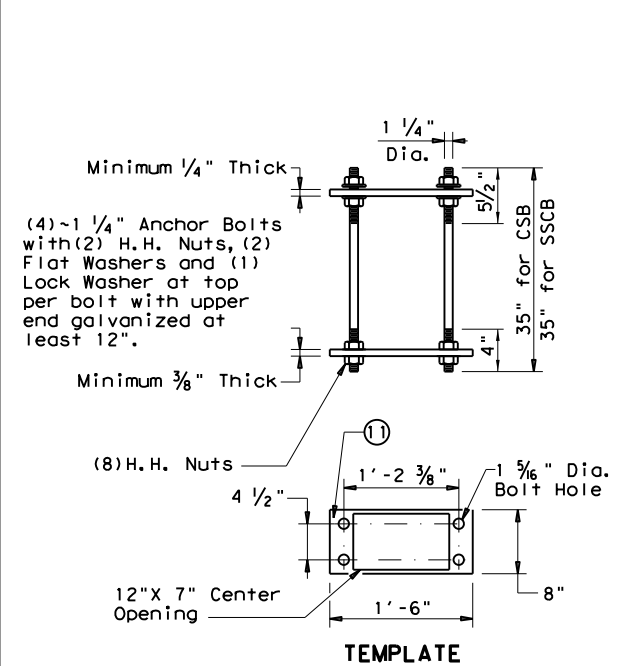

CONCRETE TRAFFIC BARRIER BASE ANCHOR BOLT ASSEMBLY

CONCRETE TRAFFIC BARRIER BASE ANCHOR BOLT ASSEMBLY TABLE				
MOUNTING HEIGHTS (nominal)	A.B. Dia.	BOLT CIRCLE DIAMETER	CTR. HOLE DIAMETER	BOLT HOLE DIAMETER
20' - 39'	1"	14"	12"	1 1/16"
40' - 50'	1 1/4"	17 1/4"	14 3/4"	1 5/16"

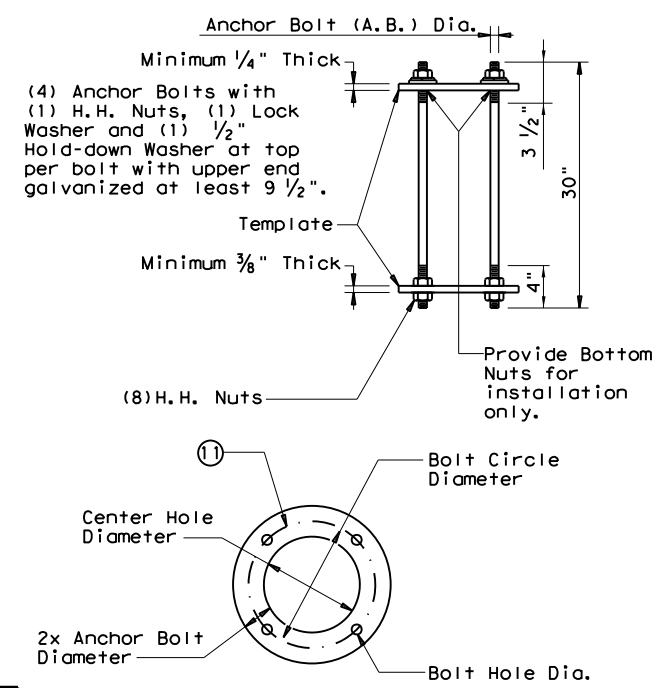

TRANSFORMER BASE ANCHOR BOLT ASSEMBLY

TRANSFORMER BASE TABLE		
TYPE	TOP B.C.	BTM. B.C.
A	13"	14"
B	15"	17 1/4"

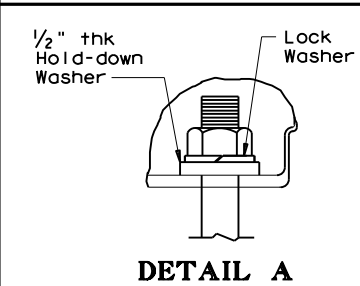

DETAIL A

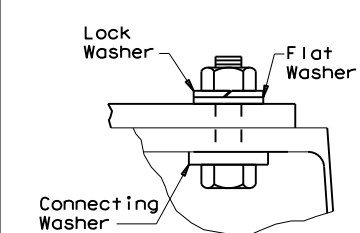

DETAIL B

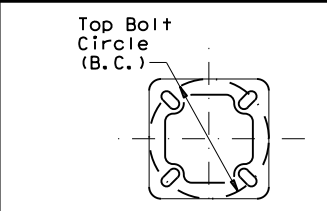

TOP PLAN

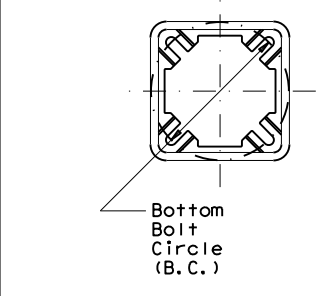

BOTTOM PLAN

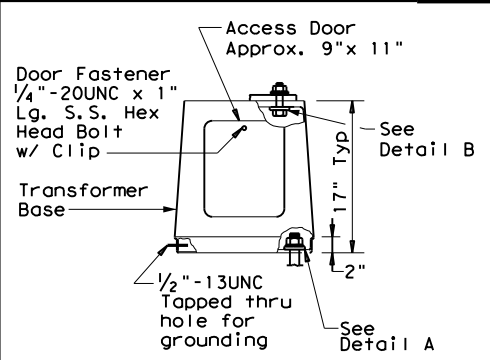

ELEVATION

TRANSFORMER BASE DETAILS

GENERAL NOTES:

- For mounting heights between those shown in the table, use the values in the table for the larger mounting height.
- All breakaway bases shall meet the breakaway requirements of the AASHTO Standard Specifications for Structural Supports for Highway Signs, Luminaires and Traffic Signals, 6th Edition (2013) and Interim Revisions thereto, and shall have been tested by FHWA-approved methods. All bases shall have been structurally tested to resist 150% of the design moment.
- Transformer bases shall be cast from aluminum, ASTM B108 or B26 Alloy 356.0-T6, or other material approved by the Engineer. Four Hex Head (H.H.) bolts with four H.H. nuts, four lock washers, four flat washers, and connecting and hold-down washers as recommended by the manufacturer, galvanized to ASTM A153 Class C or D, or B695 Class 50, shall be provided with each transformer base for connecting the pole. Bolts shall be ASTM A325 or approved equal. Nuts shall be ASTM A563 grade DH galvanized.
- Bases shall be stamped, incised or by other approved permanent means, marked to show fabricator's name or logo, and model number. Such information shall be placed in a readily seen location, inside or outside the base, but shall not be placed on the door.
- Doors for transformer bases shall be made of plastic, fiberglass or other non-metallic material approved by the Engineer and shall be attached with stainless steel screws or bolts. Transformer bases shall be cleaned by grit blast cleaning after heat treatment. Certification by the manufacturer of heat treatment shall be furnished with transformer bases. The certification shall show the metal alloy and temper and that the base meets those requirements, chemical and physical. The certification shall also show the material ASTM specification. Transformer bases shall be cast with a removable tab bar for material testing. Some bars may have been removed by the manufacturer for testing.

NOTES:

- Anchor Bolt Templates do not need to be galvanized.
- Pole diameter before ovalized.

ANCHOR BOLT FABRICATION TOLERANCES TABLE	
DIMENSION	TOLERANCE
Length	± 1/2"
Threaded length	± 1/2"
Galvanized length (if required)	- 1/4"



**ROADWAY ILLUMINATION POLES
RIP(4)-19**

FILE: rip-19.dgn	DW: CK:	DW: CK:
© TxDOT January 2007	CONT SECT	JOB HIGHWAY
REVISIONS	0010 08	060 US 67
7-17	DIST COUNTY	SHEET NO.
12-19	ATL MORRIS	94

DISCLAIMER: The use of this standard is governed by the "Texas Engineering Practice Act." No warranty of any kind is made by TxDOT for any purpose whatsoever. TxDOT assumes no responsibility for the conversion of this standard to other formats or for incorrect results or damages resulting from its use.

I. WORK AT CROSSING LOCATIONS (AT GRADE, HIGHWAY OVERPASS, HIGHWAY UNDERPASS, PEDESTRIAN, OR CLOSED/ABANDONED)

This project is adjacent or parallel work, not within RR ROW:
 DOT No.: 794662S
 Crossing Type: At Grade
 RR Company Operating Track at Crossing: Union Pacific Railroad
 RR Company Owning Track at Crossing: Union Pacific Railroad
 RR MP: 104.47
 RR Subdivision: Mineola
 City: Gladewater
 County: Upshur
 CSJ at this Crossing: 0096-03-078
 Latitude: 32.5453414
 Longitude: -94.9701160

Scope of Work, including any TCP, to be performed by State Contractor:

No work within the railroad right of way and no traffic control devices in railroad right of way. All work will be performed on US 80 main lanes and will have no effect on the adjacent crossing. TxDOT to install illumination poles near the Railroad right of way.

Scope of Work to be performed by Railroad Company:

Perform protective flagging to make sure no issues of fouling track with any equipment and to ensure construction does not block and que traffic at the crossing itself.

II. FLAGGING & INSPECTION

No. of Days of Railroad Flagging Expected: 5
 On this project, night or weekend flagging is:
 Expected
 Not Expected

Flagging services will be provided by:

Railroad Company: 1) Txdot will pay flagging invoices. Flagging Agreement with railroad will be needed or, 2) Permitted crossing. Railroad company to provide flagging.
 Outside Party: Contractor will pay flagging invoices to be reimbursed by TxDOT

Contractor must incorporate flaggers into anticipated construction schedule. The Railroad requires a 30-day notice if their flaggers are to be utilized. If Contractor falls behind schedule due to their own negligence and is not ready for scheduled flaggers, any flagging charges will be paid by Contractor.

Contact Information for Flagging:

UPRR UP.info@railpros.com
 Call Center 877-315-0513, Select #1 for flagging
 UP.request@nrssinc.net
 Call Center 877-984-6777

BNSF BNSFinfo@railprofs.com
 Call Center 877-315-0513, Select #1 for flagging

CPKCR KCS.info@railpros.com
 Call Center 877-315-0513, Select #1 for flagging
 Bottom Line On-Track Safety Services
 bottomline076@aol.com, 903-767-7630

OTHERS:

Contractor must incorporate railroad construction inspection into anticipated construction schedule.

Not Required
 Required. Contact Information for Construction Inspection:

III. CONSTRUCTION WORK TO BE PERFORMED BY THE RAILROAD

Required.
 Not Required
 Railroad Point of Contact: _____

Coordinate with TxDOT for any work to be performed by the Railroad Company. TxDOT must issue a work order for any work done by the Railroad Company prior to the work being performed.

IV. RAILROAD INSURANCE REQUIREMENTS

The Contractor shall confirm the insurance requirements with the Railroad as the insurance limits are subject to change without notice.

Insurance policies and corresponding certificates of insurance must be issued by the contractor on behalf of the Railroad. Separate insurance policies and certificates are required when more than one Railroad Company is operating on the same right of way, or when several Railroad Companies are involved and operate on their own separate right of ways.

No direct compensation will be made to the Contractor for providing the insurance coverages shown below or any deductibles. These costs are incidental to the various bid items.

Escalated Limits	
Type of Insurance	Amount of Coverage (Minimum)
Workers Compensation	\$500,000 / \$500,000 / \$500,000
Commercial General Liability	\$2,000,000 / \$4,000,000
Business Automobile	\$2,000,000

Railroad Protective Liability Limits	
<input type="checkbox"/> Not Required	
<input checked="" type="checkbox"/> Non - Bridge/Typical Maintenance Projects. Includes repairs to overpass/underpass and culvert structures	\$2,000,000 / \$6,000,000
<input type="checkbox"/> Bridge Structure Projects. Includes new construction or replacement of overpass/underpass structures	\$5,000,000 / \$10,000,000
<input type="checkbox"/> Other: _____	

V. CONTRACTOR'S RIGHT OF ENTRY (CROE)

Not Required
 Required: UPRR Maintenance Consent Letter. TxDOT to assist
 Required: TxDOT to assist in obtaining the UPRR CROE
 Required: Contractor to obtain

- BNSF: _____
https://bnsf.railpermitting.com
- CPKCR
https://jllrpg.360works.com/fmi/webd/rpo_web_kcs.fmp12
- Other Railroads: _____

To view previously approved CROE templates agreed upon between the State and Railroad, see: <https://www.txdot.gov/business/resources/railroad-highway-crossing/sample-right-of-entry-agreements.html>

Approved CROE templates are not to be modified by the Contractor.

Contractor shall not operate within Railroad Right of Way without an executed Construction & Maintenance Agreement between the State and the Railroad and an executed CROE between the Contractor and the Railroad if required on project.

VI. RAILROAD COORDINATION MEETING

A Railroad Coordination Meeting is required. See item 5, Article 8.1, of the Standard Specifications for Construction and Maintenance of Highways, Streets and Bridges Manual for more details.

VII. RAILROAD SAFETY ORIENTATION

A. Complete the Railroad's course "Orientation for Contractor's Safety," and maintain registration prior to working on the Railroad's property. This course is required to be completed annually by Contractor and Subcontractor personnel working on site.

UPRR, BNSF, CPKCR will not accept on-track safety training certificates from other Railroads. Refer to each Railroad's specific contractor right of entry for training information.

Know and follow the Contractor's Right of Entry Agreement EXHIBIT D, MINIMUM SAFETY REQUIREMENTS regarding clothing, personal protective equipment, and general safety requirements.

VIII. SUBCONTRACTORS

Contractor shall not subcontract work without written consent of TxDOT. Subcontractors are subject to the same insurance requirements as the Prime Contractor.

IX. EMERGENCY NOTIFICATION

In Case of Railroad Emergency
 Call: Union Pacific Railroad Emergency Line
 Railroad Emergency Line at: 888-877-7267
 Location: DOT 794662S
 RR Milepost: 104.47
 Subdivision: Mineola

RRD Review Only
 Initials: KS
 Date: 1-12-2024

		Rail Division
RAILROAD SCOPE OF WORK PROJECT SPECIFIC DETAILS		
FILE: rr-scope-of-work.pdf	DN: TxDOT	CK: _____
© TxDOT June 2014	CONT	SECT
REVISIONS	0010	08
6/2023	JOB	
	060 US 67	
	DIST	COUNTY
	ATL	MORRIS
		SHEET NO.
		212

PART 1 - GENERAL

1.01 DESCRIPTION

This project includes construction work within the right of way and/or properties of the Railroad and adjacent to its tracks, wire lines and other facilities. These sheets describe the minimum special requirements for coordination with the Railroad when working upon, over or under Railroad Right of Way or when impacting current or future Railroad operations. Coordinate with the Railroad while performing the work outlined herein, and afford the same cooperation with the Railroad as with TxDOT. Complete all submittals and work in accordance with TxDOT Standard Specifications, Railroad Guidelines and AREMA recommendations as modified by these minimum special requirements or as directed in writing by the Railroad Designated Representative.

For purposes of this project, the Railroad Designated Representative is the person or persons designated by the Railroad Manager of Industry and Public Projects to handle specific tasks related to the project.

1.02 REQUEST FOR INFORMATION / CLARIFICATION

Submit Requests for Information ("RFI") involving work within any Railroad Right of Way to the TxDOT Engineer. The TxDOT Engineer will submit the RFI to the Railroad Designated Representative for review and approval for RFI's corresponding to work within Railroad Right of Way. Allow six (6) weeks total time for review and approval, which includes four (4) weeks for review and approval by the Railroad.

1.03 PLANS / SPECIFICATIONS

TxDOT has received written Railroad approval of the plans and specifications for this project. Any revisions or changes in the plans after award of the Contract must have the approval of TxDOT and the Railroad.

PART 2 - UTILITIES AND FIBER OPTIC

Construct all utility installations in accordance with current AREMA recommendations, Railroad, TxDOT and owning utility specifications and requirements. Railroad general guidelines can be found on the Railroad website or by contacting the Railroad Designated Representative.

PART 3 - CONSTRUCTION

3.01 GENERAL

- A. Perform all work in compliance with all applicable Railroad, Federal Railroad Administration (FRA), and TxDOT rules and regulations. Arrange and conduct work in a manner that does not endanger or interfere with the safe operation of the tracks and property of the Railroad and the traffic moving on such tracks, or the wires, signals and other property of the Railroad, its tenants or licensees, at or in the vicinity of the Work. The safe operation of railroad train movements takes precedence over any work to be performed by the Contractor. The Contractor is responsible for train delay cost and lost revenue claims due to any delays or interruption of train operations resulting from Contractor's construction or other activities.
- B. Construction activities within 15 feet of the operational tracks will only be allowed if absolutely necessary and the Railroad's Designated Representative grants approval. Construction activities within 15 feet of the operational track(s) preferably allow the tracks to stay operational. In such cases, coordination and approval by the Railroad Track Manager is required with regard to schedule, flagging, and slow orders. See Sections 3.07 and 3.08 for additional information.
- C. Provide track protection for all work equipment (including rubber tired equipment) operating within 25 feet from nearest rail. When not in use, keep Contractor machinery and materials at least 50 feet from the Railroad's nearest track.
- D. Vehicular crossings of railroad track are allowed only at existing crossings, or haul road crossings developed with Railroad approval.
- E. The Contractor is also advised that new railroad facilities within the project may be built by the Railroad. If applicable, these facilities are delineated in the plans. Be aware of the limits of responsibilities and coordinate efforts with the Railroad and TxDOT.
- F. Railroad requirements do not allow work within 50 feet of track centers when a train passes the work site and all personnel must clear the area within 50 feet of the track centerline and secure all equipment. Additional allowances may be pursued as outlined in 3.02 and 3.03.
- G. All permanent clearances shall be verified before project closing.

3.02 RAILROAD OPERATIONS

- A. Trains and/or equipment are expected on any track, at any time, in either direction. Become familiar with the train schedules in this location and structure bid assuming intermittent track windows in this period, as defined in Paragraph B that follows.
- B. All railroad tracks within and adjacent to the contract site are active, and rail traffic over these facilities shall be maintained throughout the Project. Activities may include both through moves and switching moves to local customers. railroad traffic and operations will occur continuously throughout the day and night on these tracks and shall be maintained at all times as defined herein. Coordinate and schedule the work so that construction activities do not interfere with railroad operations.
- C. Coordinate work windows with TxDOT and the Railroad's Designated Representative. Types of work windows include Conditional Work Windows and Absolute Work Windows, as defined below:
 - 1. Conditional Work Window: A Conditional Work Window is a period of time that railroad operations have priority over construction activities. When construction activities may occur on and/or adjacent to the railroad tracks within 25 feet of the nearest track, a railroad flag person will be required. At the direction of the railroad flag person, upon approach of a train, and when trains are present on the tracks, the tracks must be cleared (i.e., no construction equipment, materials or personnel within 25 feet, or as directed by the Railroad Designated Representative, from the tracks). Conditional Work Windows are available for the Project.
 - 2. Absolute Work Window: An Absolute Work Window is a period of time that construction activities are given priority over railroad operations. During this time frame, the designated railroad track(s) will be inactive for train movements and may be fouled by the Contractor. At the end of an Absolute Work Window, the railroad tracks and/or signals must be completely operational for train operations and all Railroad, Public Utilities Commission (PUC) and FRA requirements, codes and regulations for operational tracks must be satisfied. In the situation where the operating tracks and/or signals have been affected, the Railroad will perform inspections of the work prior to placing that track back into service. Railroad flag persons will be required for construction activities requiring an Absolute Work Window. Absolute Work Windows will not generally be granted. Any request will require a detailed explanation for Railroad review.

3.03 RIGHT OF ENTRY, ADVANCE NOTICE AND WORK STOPPAGES

- A. Do not perform any work within Railroad Right of Way without a valid executed Right of Entry Agreement if required on this project.
- B. Give advance notice to the Railroad as required in the "Contractor's Right of Entry Agreement" before commencing work in connection with construction upon or over Railroad Right of Way and observe the Railroad's rules and regulations with respect thereto.
- C. Perform all work upon Railroad Right of Way in a manner to avoid interference with or endanger the operations of the Railroad. Whenever work may affect the operations or safety of trains, submit the work method to the Railroad Designated Representative for approval. Approval does not relieve the Contractor from liability. Do not commence any work which requires flagging service or inspection service until the flagging protection required by the Railroad is available at the job site. See Section 3.15 for railroad flagging requirements.
- D. Make requests in writing for both Absolute and Conditional Work Windows, at least 30 days in advance of any work. Include in the written request:
 - 1. Exactly what the work entails.
 - 2. The days and hours that work will be performed.
 - 3. The exact location of work, and proximity to the tracks.
 - 4. The type of window requested and the amount of time requested.
 - 5. The designated contact person.

Provide a written confirmation notice to the Railroad at least 48 hours before commencing work in connection with approved work windows when work is within 25 feet of nearest rail. Perform all work in accordance with previously approved work plans.
- E. Make provisions to protect operations and property of the Railroad should a condition arising from, or in connection with the work, require immediate and unusual action. If in the judgment of the Railroad Designated Representative such provisions are insufficient, the Railroad Designated Representative may require or provide such provisions as deemed necessary. In any event, such provisions shall be at the Contractor's expense and without cost to the Railroad or TxDOT. The Railroad or TxDOT shall have the right to order the Contractor to temporarily cease operations in the event of an emergency or, if in the opinion of the Railroad Designated Representative, the Contractor's operations could endanger railroad operations. In the event of such an order, immediately notify TxDOT of the order.

3.04 INSURANCE

Do not begin work upon or over Railroad Right of Way until furnishing the Railroad with the insurance policies, binders, certificates and endorsements required by the "Contractor's Right of Entry Agreement", and until the Railroad Designated Representative has advised TxDOT that such insurance is in accordance with the Agreement.

3.05 RAILROAD SAFETY ORIENTATION

- A. Complete the railroad course "Orientation for Contractor's Safety", and maintain current registration prior to working on railroad property. This course is required to be completed annually by Contractor and Subcontractor personnel working on site.

"UPRR, BNSF, KCS/TEXMEX will not accept on-track safety training certificates from other railroads. Refer to Railroad specific contractor right of entry for training information."
- B. Know and follow the "Contractor's Right of Entry Agreement" EXHIBIT D, MINIMUM SAFETY REQUIREMENTS regarding clothing, personal protective equipment, and general safety requirements.

3.06 COOPERATION

The Railroad will cooperate with Contractor so that work may be conducted in an efficient manner, and will cooperate with Contractor in enabling use of Railroad Right of Way in performing the work.

3.07 MINIMUM CONSTRUCTION CLEARANCES FOR FALSEWORK AND OTHER TEMPORARY STRUCTURES

Abide by the following minimum temporary clearances during the course of construction:
A. 15' - 0" (BNSF) (UPRR) and 14' - 0" (KCS) horizontal from centerline of track
B. 22' (KCS) and 21' - 6" (UPRR & BNSF) vertically above top of rail.

For construction clearance less than listed above, obtain local Railroad Operating Unit review and approval.

3.08 APPROVAL OF REDUCED CLEARANCES

- A. Maintain minimum track clearances during construction as specified in Section 3.07.
- B. Submit any proposed infringement on the specified minimum clearances to the Railroad Designated Representative through TxDOT at least 30 days in advance of the work. Do not proceed with such infringement without written approval by the Railroad Designated Representative.
- C. Do not commence work involving an approved infringement without receiving written assurance from the Railroad Designated Representative that arrangements have been made for any necessary flagging service.

 Texas Department of Transportation				Rail Division	
RAILROAD REQUIREMENTS FOR NON-BRIDGE CONSTRUCTION PROJECTS					
FILE:	DN: TxDOT	CK: TxDOT	DW: TxDOT	CR: TxDOT	
© TxDOT October 2018	CONT	SECT	JOB	HIGHWAY	
REVISIONS March 2020	0010	08	060	US 67	
	DIST	COUNTY	SHEET NO.		
	ATL	MORRIS	96		

DATE: 1/12/2024 2:50:51 PM
FILE: I:\Engdat\Traffic\UGM\192515_Jamie\JOBS\LIGHTING PROJECTS\Lighting Project May 2024\standards\Non Bridge-Projects (2).dgn

DATE: 1/12/2024 2:52:05 PM
 FILE: T:\Engdat\Traffic\JG\192515_Jamie\JOBS\LIGHTING PROJECTS\Lighting Project May 2024\standards\Non Bridge-Projects (2).dgn

3.09 MAINTENANCE OF RAILROAD FACILITIES

- A. Maintain all ditches and drainage structures free of silt or other obstructions resulting from Contractor's operations. Repair eroded areas and any other damage within Railroad Right of Way and repair any other damage to the property of the Railroad, or its tenants.
- B. Perform all such maintenance and repair of damages due to the Contractors's operations at Contractor's expense.
- C. Submit a proposed method of erosion control for review by the Railroad prior to beginning any grading on the project site. Comply with all applicable local, state and federal regulations when developing and implementing such erosion control.

3.10 SITE INSPECTIONS BY RAILROAD'S DESIGNATED REPRESENTATIVE

- A. In addition to the office reviews of construction submittals, site inspections may be performed by the Railroad Designated Representative at significant points during construction, including the following if applicable:
 1. Pre-construction meetings.
 2. Pile driving/drilling of caissons or drilled shafts.
 3. Reinforcement and concrete placement for railroad bridge substructure and/or superstructure.
 4. Erection of precast concrete or steel bridge superstructure.
 5. Placement of waterproofing (prior to placing ballast on bridge deck).
 6. Completion of the bridge structure.
- B. Site inspection is not limited to the milestone events listed above. Site visits to check progress of the work may be performed at any time throughout the construction as deemed necessary by the Railroad.
- C. Provide a detailed construction schedule, including the proposed temporary horizontal and vertical clearances and construction sequence for all work to TxDOT for submittal to the Railroad Designated Representative for review prior to commencement of work. Include the anticipated dates when the above listed events will occur. Update this schedule for the above listed events as necessary and each month at a minimum to allow the Railroad to schedule site inspections.

3.11 RAILROAD REPRESENTATIVES

Railroad representatives, conductors, flag person or watch person will be provided by the Railroad at expense of TxDOT to protect Railroad facilities, property and movements of its trains or engines. In general, the Railroad will furnish such personnel or other protective services as follows:

- A. When any part of any equipment is standing or being operated within 25 feet, measured horizontally, from nearest rail of any track on which trains may operate, or when any object is off the ground and any dimension thereof could extend inside the 25 foot limit, or when any erection or construction activities are in progress within such limits, regardless of elevation above or below track.
- B. For any excavation below elevation of track subgrade if, in the opinion of the Railroad Designated Representative, track or other railroad facilities may be subject to settlement or movement.
- C. During any clearing, grubbing, excavation or grading in proximity to railroad facilities, which, in the opinion of the Railroad Designated Representative, may endanger railroad facilities or operations.
- D. During any Contractor's operations when, in the opinion of the Railroad Designated Representative, railroad facilities, including, but not limited to, tracks, buildings, signals, wire lines, or pipe lines, may be endangered.
- E. Arrange with the Railroad Designated Representative to provide the adequate number of flag persons to accomplish the work.

3.12 COMMUNICATIONS AND SIGNAL LINES

If required, the Railroad will rearrange its communications and signal lines, its grade crossing warning devices, train signals and tracks, and facilities that are in use and maintained by the Railroad's forces in connection with its operation at expense of TxDOT. This work by the Railroad will be done by its own forces and it is not a part of the Work under this Contract.

3.13 TRAFFIC CONTROL

Coordinate any operations that control traffic across or around railroad facilities with the Railroad Designated Representative.

3.14 CONSTRUCTION EXCAVATIONS AND BORING ACTIVITIES UNDER TRACK

- A. Take special precaution and care in connection with excavating and shoring. Excavations for construction of footings, piers, columns, walls or other facilities that require shoring shall comply with requirements of TxDOT, OSHA, AREMA and Railroad "Guidelines for Temporary Shoring".
- B. The project plans indicate whether there are fiber optic lines or other such telecommunications systems that require consideration. Regardless, contact the necessary call center to determine if such cable systems are present:

UPRR 1-800-336-9193
 7:00 AM to 9:00 PM CST Monday-Friday except holidays,
 staffed 24 hrs/day for emergencies
 48 hrs notice required

BNSF 1-800-533-2891
 24 hour number
 5 working days notice required

KCS 1-800-344-8377
 Texas One Call, a 24 hour number
 48 hrs notice required, excluding weekends and holidays

If a telecommunications system is buried anywhere on or near railroad property, coordinate with TxDOT, the Railroad and the Telecommunication Company(ies) to arrange for relocation or protective measures prior to beginning work on or near railroad property. Refer to the project General Notes for additional information.

- C. Projects involving a boring or jack and bore operation under track such as drainage pipes or culverts and utilities require an installation plan reviewed and approved by the Railroad and TxDOT prior to proceeding with such construction. A railroad inspector and contractor assisted monitoring of ground and track movement is required to maintain safe passage of rail traffic. Stop installation and do not allow passage of trains if movements in excess of 1/4 inch vertical or horizontal is detected in the tracks. Immediately repair the damage to the satisfaction of TxDOT and the Railroad before proceeding.

3.15 RAILROAD FLAGGING

Per the Right of Entry Agreement for flagging, notify the Railroad Representative at least 10 working days in advance of Contractor's work and at least 30 working days in advance of any Contractor's work in which any person or equipment will be within 25 feet of nearest rail or as specified in the Contractor Right of Entry (CROE).

3.16 CLEANING OF RIGHT-OF-WAY

When work is complete, remove all tools, implements, and other materials brought into Railroad Right of Way and leave the right of Way in a clean and presentable condition to the satisfaction of TxDOT and the Railroad.

Texas Department of Transportation				Rail Division	
RAILROAD REQUIREMENTS FOR NON-BRIDGE CONSTRUCTION PROJECTS					
FILE:	DN: TxDOT	CK: TxDOT	DW: TxDOT	CR: TxDOT	
©TxDOT October 2018	CONT	SECT	JOB	HIGHWAY	
REVISIONS March 2020	0010	08	060	US 67	
DIST	COUNTY			SHEET NO.	
ATL	MORRIS			97	

DISCLAIMER: The use of this standard is governed by the "Texas Engineering Practice Act". No warranty of any kind is made by TxDOT for any purpose whatsoever. TxDOT assumes no responsibility for the conversion of this standard to other formats or for incorrect results or damages resulting from its use.

DATE: DATE TIME
 FILE: DOCUMENT NAME

I. STORMWATER POLLUTION PREVENTION-CLEAN WATER ACT SECTION 402

TPDES TXR 150000: Stormwater Discharge Permit or Construction General Permit required for projects with 1 or more acres disturbed soil. Projects with any disturbed soil must protect for erosion and sedimentation in accordance with Item 506.

List MS4 Operator(s) that may receive discharges from this project. They may need to be notified prior to construction activities.

1. There are no MS4 Operators in the project area.

2. No Action Required Required Action

Action No.

1. This project is considered a maintenance activity and is exempt from the requirements of TPDES TXR 150000.

Commitment No.

1. Refer to the SWP3 Plan Sheet, BMPs, and Detail. It will address sweeping, chemical storage, sanitary waste, and all other management practices.

II. WORK IN OR NEAR STREAMS, WATERBODIES AND WETLANDS CLEAN WATER ACT SECTIONS 401 AND 404

USACE Permit required for filling, dredging, excavating or other work in any water bodies, rivers, creeks, streams, wetlands or wet areas.

The Contractor must adhere to all of the terms and conditions associated with the following permit(s):

- No Permit Required
- Nationwide Permit 14 - PCN not Required (less than 1/10th acre waters or wetlands affected)
- Nationwide Permit 14 - PCN Required (1/10 to <1/2 acre, 1/3 in tidal waters)
- Individual 404 Permit Required
- Other Nationwide Permit Required: NWP# _____

Required Actions: List waters of the US permit applies to, location in project and check Best Management Practices planned to control erosion, sedimentation and post-project TSS.

- 1.
- 2.
- 3.
- 4.

The elevation of the ordinary high water marks of any areas requiring work to be performed in the waters of the US requiring the use of a nationwide permit can be found on the Bridge Layouts.

Best Management Practices:

Erosion	Sedimentation	Post-Construction TSS
<input type="checkbox"/> Temporary Vegetation	<input type="checkbox"/> Silt Fence	<input type="checkbox"/> Vegetative Filter Strips
<input type="checkbox"/> Blankets/Matting	<input type="checkbox"/> Rock Berm	<input type="checkbox"/> Retention/Irrigation Systems
<input type="checkbox"/> Mulch	<input type="checkbox"/> Triangular Filter Dike	<input type="checkbox"/> Extended Detention Basin
<input type="checkbox"/> Sodding	<input type="checkbox"/> Sand Bag Berm	<input type="checkbox"/> Constructed Wetlands
<input type="checkbox"/> Interceptor Swale	<input type="checkbox"/> Straw Bale Dike	<input type="checkbox"/> Wet Basin
<input type="checkbox"/> Diversion Dike	<input type="checkbox"/> Brush Berms	<input type="checkbox"/> Erosion Control Compost
<input type="checkbox"/> Erosion Control Compost	<input type="checkbox"/> Erosion Control Compost	<input type="checkbox"/> Mulch Filter Berm and Socks
<input type="checkbox"/> Mulch Filter Berm and Socks	<input type="checkbox"/> Mulch Filter Berm and Socks	<input type="checkbox"/> Compost Filter Berm and Socks
<input type="checkbox"/> Compost Filter Berm and Socks	<input type="checkbox"/> Compost Filter Berm and Socks	<input type="checkbox"/> Vegetation Lined Ditches
	<input type="checkbox"/> Stone Outlet Sediment Traps	<input type="checkbox"/> Sand Filter Systems
	<input type="checkbox"/> Sediment Basins	<input type="checkbox"/> Grassy Swales

III. CULTURAL RESOURCES

Refer to TxDOT Standard Specifications in the event historical issues or archeological artifacts are found during construction. Upon discovery of archeological artifacts (bones, burnt rock, flint, pottery, etc.) cease work in the immediate area and contact the Engineer immediately.

No Action Required Required Action

Action No.

- 1.
- 2.
- 3.
- 4.

IV. VEGETATION RESOURCES

Preserve native vegetation to the extent practical. Contractor must adhere to Construction Specification Requirements Specs 162, 164, 192, 193, 506, 730, 751, 752 in order to comply with requirements for invasive species, beneficial landscaping, and tree/brush removal commitments.

No Action Required Required Action

Action No.

- 1.
- 2.
- 3.
- 4.

V. FEDERAL LISTED, PROPOSED THREATENED, ENDANGERED SPECIES, CRITICAL HABITAT, STATE LISTED SPECIES, CANDIDATE SPECIES AND MIGRATORY BIRDS.

No Action Required Required Action

Action No.

- 1.
- 2.
- 3.
- 4.

If any of the listed species are observed, cease work in the immediate area, do not disturb species or habitat and contact the Engineer immediately. The work may not remove active nests from bridges and other structures during nesting season of the birds associated with the nests. If caves or sinkholes are discovered, cease work in the immediate area, and contact the Engineer immediately.

LIST OF ABBREVIATIONS

BMP: Best Management Practice	SPCC: Spill Prevention Control and Countermeasure
CGP: Construction General Permit	SW3P: Storm Water Pollution Prevention Plan
DSHS: Texas Department of State Health Services	PCN: Pre-Construction Notification
FHWA: Federal Highway Administration	PSL: Project Specific Location
MOA: Memorandum of Agreement	TCEQ: Texas Commission on Environmental Quality
MOU: Memorandum of Understanding	TPDES: Texas Pollutant Discharge Elimination System
MS4: Municipal Separate Stormwater Sewer System	TPWD: Texas Parks and Wildlife Department
MBTA: Migratory Bird Treaty Act	TxDOT: Texas Department of Transportation
NOT: Notice of Termination	T&E: Threatened and Endangered Species
NWP: Nationwide Permit	USACE: U.S. Army Corps of Engineers
NOI: Notice of Intent	USFWS: U.S. Fish and Wildlife Service

VI. HAZARDOUS MATERIALS OR CONTAMINATION ISSUES

General (applies to all projects):

Comply with the Hazard Communication Act (the Act) for personnel who will be working with hazardous materials by conducting safety meetings prior to beginning construction and making workers aware of potential hazards in the workplace. Ensure that all workers are provided with personal protective equipment appropriate for any hazardous materials used. Obtain and keep on-site Material Safety Data Sheets (MSDS) for all hazardous products used on the project, which may include, but are not limited to the following categories: Paints, acids, solvents, asphalt products, chemical additives, fuels and concrete curing compounds or additives. Provide protected storage, off bare ground and covered, for products which may be hazardous. Maintain product labelling as required by the Act.

Maintain an adequate supply of on-site spill response materials, as indicated in the MSDS. In the event of a spill, take actions to mitigate the spill as indicated in the MSDS, in accordance with safe work practices, and contact the District Spill Coordinator immediately. The Contractor shall be responsible for the proper containment and cleanup of all product spills.

Contact the Engineer if any of the following are detected:

- * Dead or distressed vegetation (not identified as normal)
- * Trash piles, drums, canister, barrels, etc.
- * Undesirable smells or odors
- * Evidence of leaching or seepage of substances

Does the project involve any bridge class structure rehabilitation or replacements (bridge class structures not including box culverts)?

Yes No

If "No", then no further action is required.

If "Yes", then TxDOT is responsible for completing asbestos assessment/inspection.

Are the results of the asbestos inspection positive (is asbestos present)?

Yes No

If "Yes", then TxDOT must retain a DSHS licensed asbestos consultant to assist with the notification, develop abatement/mitigation procedures, and perform management activities as necessary. The notification form to DSHS must be postmarked at least 15 working days prior to scheduled demolition.

If "No", then TxDOT is still required to notify DSHS 15 working days prior to any scheduled demolition.

In either case, the Contractor is responsible for providing the date(s) for abatement activities and/or demolition with careful coordination between the Engineer and asbestos consultant in order to minimize construction delays and subsequent claims.

Any other evidence indicating possible hazardous materials or contamination discovered on site. Hazardous Materials or Contamination Issues Specific to this Project:

No Action Required Required Action

Action No.

- 1.
- 2.
- 3.

VII. OTHER ENVIRONMENTAL ISSUES

(includes regional issues such as Edwards Aquifer District, etc.)

No Action Required Required Action

Action No.

- 1.
- 2.
- 3.

 Texas Department of Transportation		Design Division Standard		
<h2 style="margin: 0;">ENVIRONMENTAL PERMITS, ISSUES AND COMMITMENTS EPIC</h2>				
FILE: epic.dgn	DN: TxDOT	CK: RG	DW: VP	CK: AR
©TxDOT: February 2015	CONT	SECT	JOB	HIGHWAY
12-12-2011 (DS) REVISIONS	0010	08	060	US 67
05-07-14 ADDED NOTE SECTION IV.	DIST	COUNTY	SHEET NO.	
01-23-2015 SECTION I (CHANGED ITEM 1122 TO ITEM 506, ADDED GRASSY SWALES.	ATL	MORRIS	98	