

STATE OF TEXAS  
DEPARTMENT OF TRANSPORTATION

PLANS OF PROPOSED  
HIGHWAY ROUTINE MAINTENANCE CONTRACT

INDEX OF SHEETS  
SHEET NO. DESCRIPTION

GENERAL

REFER TO SHEET 2 FOR INDEX

TYPE OF WORK:

MBGF AND CABLE BARRIER REPAIR

PROJECT NO.: RMC 643538001

HIGHWAY: IH10, etc

LIMITS OF WORK: VARIOUS LOCATIONS IN JEFFERSON, HARDIN AND TYLER COUNTIES

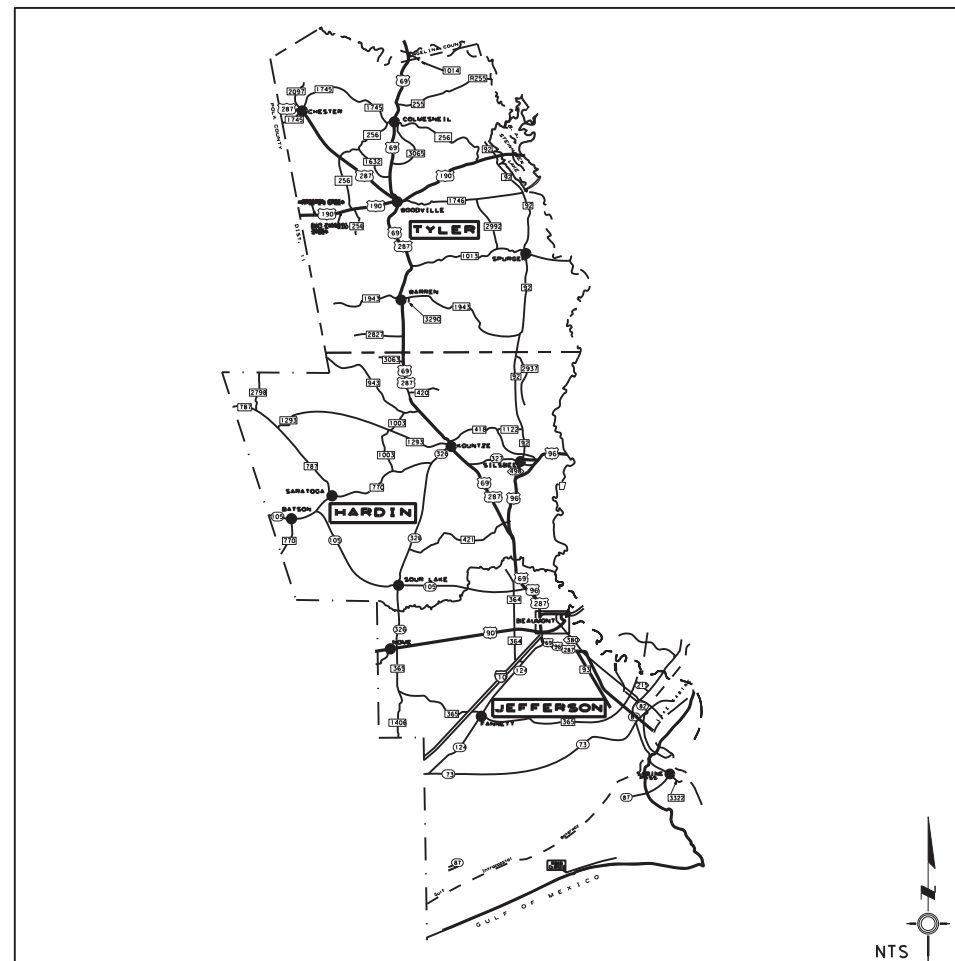

EXCEPTIONS: NONE  
EQUATIONS: NONE  
RAILROADS: NONE

© by Texas Department of Transportation;  
all rights reserved.

SPECIFICATIONS ADOPTED BY THE TEXAS DEPARTMENT OF TRANSPORTATION,  
NOVEMBER 1, 2014, AND SPECIAL SPECIFICATION ITEMS INCLUDED IN THE  
CONTRACT SHALL GOVERN ON THIS PROJECT.

MAINTENANCE PROJECT NO.			SHEET NO.
RMC643538001			1
STATE	STATE DIST. NO.	COUNTY	
TEXAS	BMT	JEFFERSON, etc	
CONT.	SECT.	JOB	HIGHWAY NO.
6435	38	001	IH10, etc

MANAGER NO. 50

MAINT. SECT.: 02, 03, 08 & 09

AREA OF DISTURBED SOIL = 0.0 ACRES

FINAL PLANS	
DATE LET :	_____
DATE WORK BEGAN:	_____
DATE WORK COMPLETED:	_____
CONTRACTOR:	_____
USED _____ OF _____ DAYS ALLOTTED	
PROJECT COST:	_____
PROJECT CONSTRUCTED AND FINAL PLANS PREPARED BY:	_____
	DATE _____

REQUIRED SIGNS SHALL BE IN ACCORDANCE WITH BC (1)-21 THRU BC (12)-21 AND THE "TEXAS MANUAL ON UNIFORM TRAFFIC CONTROL DEVICES".

RECOMMENDED FOR LETTING: 4/20/2023

DocuSigned by:  
*Peter Jungen*  
3800F88D3856401

CHAIRPERSON, DISTRICT SAFETY REVIEW TEAM



SUBMITTED FOR LETTING: 4/19/2023

DocuSigned by:  
*[Signature]*, P.E.  
380C38CA8E4E1

PROJECT ENGINEER

RECOMMENDED FOR LETTING: 4/24/2023

DocuSigned by:  
*[Signature]*, P.E.  
F4E2ECC9AF684D0

DIRECTOR OF MAINTENANCE

APPROVED FOR LETTING: 4/24/2023

DocuSigned by:  
*[Signature]*, P.E.  
578C07495064E0

DISTRICT ENGINEER

**SHEET NUMBER DESCRIPTION**

- 1 TITLE SHEET
- 2 INDEX OF SHEETS
- 3-4 GENERAL LOCATION MAP
- 5-10 GENERAL NOTES
- 11-13 ESTIMATE & QUANTITY
- 14-15 QUANTITY SUMMARY

**TRAFFIC CONTROL PLAN**

- # 16-27 BC (1)-21 THRU BC (12)-21 "Barricade and Construction"
- # 28 TCP(1-1)-18 "TCP - Conventional Road Shoulder Work"
- # 29 TCP(1-2)-18 "TCP - One-Lane Two-Way Traffic Control"
- # 30 TCP(1-4)-18 "TCP - Lane Closures on Multilane Conventional Roads"
- # 31 TCP(1-5)-18 "TCP - Lane Closures for Divided Highways"
- # 32 TCP(2-1)-18 "TCP - Conventional Road Shoulder Work"
- # 33 TCP(2-2)-18 "TCP - One-Lane Two-Way Traffic Control"
- # 34 TCP(2-4)-18 "TCP - Lane Closures on Multilane Conventional Roads"
- # 35 TCP(2-5)-18 "TCP - Lane Closures for Divided Highways"
- # 36 TCP(5-1)-18 "TCP - Shoulder Work for Freeways/Expressways"
- # 37 TCP(6-1)-12 "TCP - Freeway Lane Closures"
- # 38 TCP(6-2)-12 "TCP - Work Area Near Ramp"
- # 39 TCP(6-3)-12 "TCP - Work Area Beyond Ramp"
- # 40 TCP(6-4)-12 "TCP - Work Area at Exit Ramp"
- # 41 TCP(6-5)-12 "Work Area Beyond Exit Ramp"
- # 42 TCP(6-8)-14 "Work in Exit Gore for ADT Greater than 10,000"
- # 43 WZ(RS)-22 "Temporary Rumble Strips "

**ROADWAY DETAILS**

- 44 CCCG-22 "Concrete Curb and Curb and Gutter"

**BARRIER (FLEXIBLE)**

- # 45 GF(31)-19 Metal Beam Guard Fence
- # 46 GF(31)DAT-19 Metal Beam Guard Fence Transition (Downstream Anchor Terminal)
- # 47 GF(31)LS-19 Metal Beam Guard Fence (Long Span)
- # 48-49 GF(31)TRTL3-20 Metal Beam Guard Fence Transition (TL3) (Thrie Beam Transition)
- # 50 GF(31)T101-19 Metal Beam Guard Fence Transition (T101)
- # 51 GF(31)T6-19 Metal Beam Guard Fence Transition (T6)
- # 52 GF(31)MS-19 Metal Beam Guard Fence (Mow Strip)
- # 53 RAIL-ADJ(A)-19 Metal Beam Guard Fence (Rail Height ADJ (A))
- # 54 RAIL-ADJ(B)-19 Metal Beam Guard Fence (Rail Height ADJ (B))
- # 55 BED-14 Bridge End Details (Metal Beam Guard Fence Applications to Rigid Rails)

**GUARDRAIL END TREATMENTS**

- # 56 SGT(10S)31-16 Single Guardrail Terminal (SOFTSTOP) (Steel Post)
- # 57 SGT(11S)31-18 Single Guardrail Terminal (MAX-TENSION) (Steel Post)
- # 58 SGT(12S)31-18 Single Guardrail Terminal (MSKT) (Steel Post)
- # 59 SGT(13S)31-18 Single Guardrail Terminal (SPIG SGET) (Steel Post)
- # 60 SGT(15)31-20 Single Guardrail Terminal (SGET-TL-3) (Steel post)

**END TREATMENT (RETROFIT-SYSTEMS ONLY) TRAFFIC ITEMS**

- # 61 SGT(14W)31-18 Single Guardrail Terminal (MSKT) (Wood Post)(RETROFIT-SYSTEM)

**ATTENUATORS / CRASH CUSHIONS**

**LOW MAINTENANCE (REDIRECTIVE, NON-GATING)**

- # 62 QGELITE(M10)(N)-20 Quadguard (ELITE) (M10) (N) (Narrow)
- # 63 QGELITE(M10)(W)-20 Quadguard (ELITE) (M10) (W) (Wide)
- # 64 REACT(M)-21 React M (NARROW)

**REUSABLE (REDIRECTIVE, NON-GATING)**

- # 65 QG(M)(W)-21 Trinity Highway Quadguard M10 System (Narrow)
- # 66 TAU(M)(N)-19 Lindsay Transportation Solutions Universal Crash Cushion (Narrow)
- # 67 QGRD(M10) (N)-20 Trinity Highway Quadguard M10 System (Narrow)

**SHEET NUMBER DESCRIPTION**

**(28 INCH) SPECIAL APPLICATIONS**

- # 68 MBGF-19 Metal Beam Guard Fence
- # 69 MBGF(TR)-19 Metal Beam Guard Fence Transition (Thrie Beam Transition)
- # 70 MBGF(T101)-19 Metal Beam Guard Fence Transition (T101 Bridge Rail)
- # 71 MBGF(MS)-19 Metal Beam Guard Fence (Mow Strip)
- # 72 BED(28)-19 Bridge End Details (28" Metal Beam Guard Fence Applications to Rigid Rails)
- # 73 CASS (TL4)-14 Trinity Cable Safety System

**TRAFFIC ITEMS**

- # 74 D&OM(1)-20 "Delineators & Object Marker Material Description"
- # 75 D&OM(2)-20 "Delineators & Object Marker Installation"
- # 76-79 D&OM(3)-20 to D&OM(6)-20 "Delineators & Object Marker Placement Details "
- # 80 D&OM(VIA)-20 "Delineators & Object Marker for Vehicle Impact Attenuators "

**ENVIRONMENTAL ISSUES**

- 81 EPIC "ENVIRONMENTAL PERMITS, ISSUES AND COMMITMENTS"

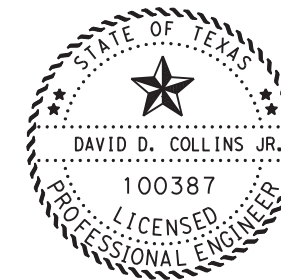

# THE STANDARD SHEETS SPECIFICALLY IDENTIFIED ABOVE HAVE BEEN SELECTED BY ME OR UNDER MY RESPONSIBLE SUPERVISION AS BEING APPLICABLE TO THIS PROJECT.

DocuSigned by: *David D. Collins Jr.*, PE 3/1/2023  
 \_\_\_\_\_, PE \_\_\_\_\_ DATE

**INDEX OF SHEETS**

FED. RD. DIV. NO.		MAINTENANCE PROJECT NO.		SHEET NO.
				2
STATE	DIST.	COUNTY		
TEXAS	BMT	JEFFERSON, etc		
CONT.	SECT.	JOB	HIGHWAY NO.	
6435	38	001	IH10, etc	

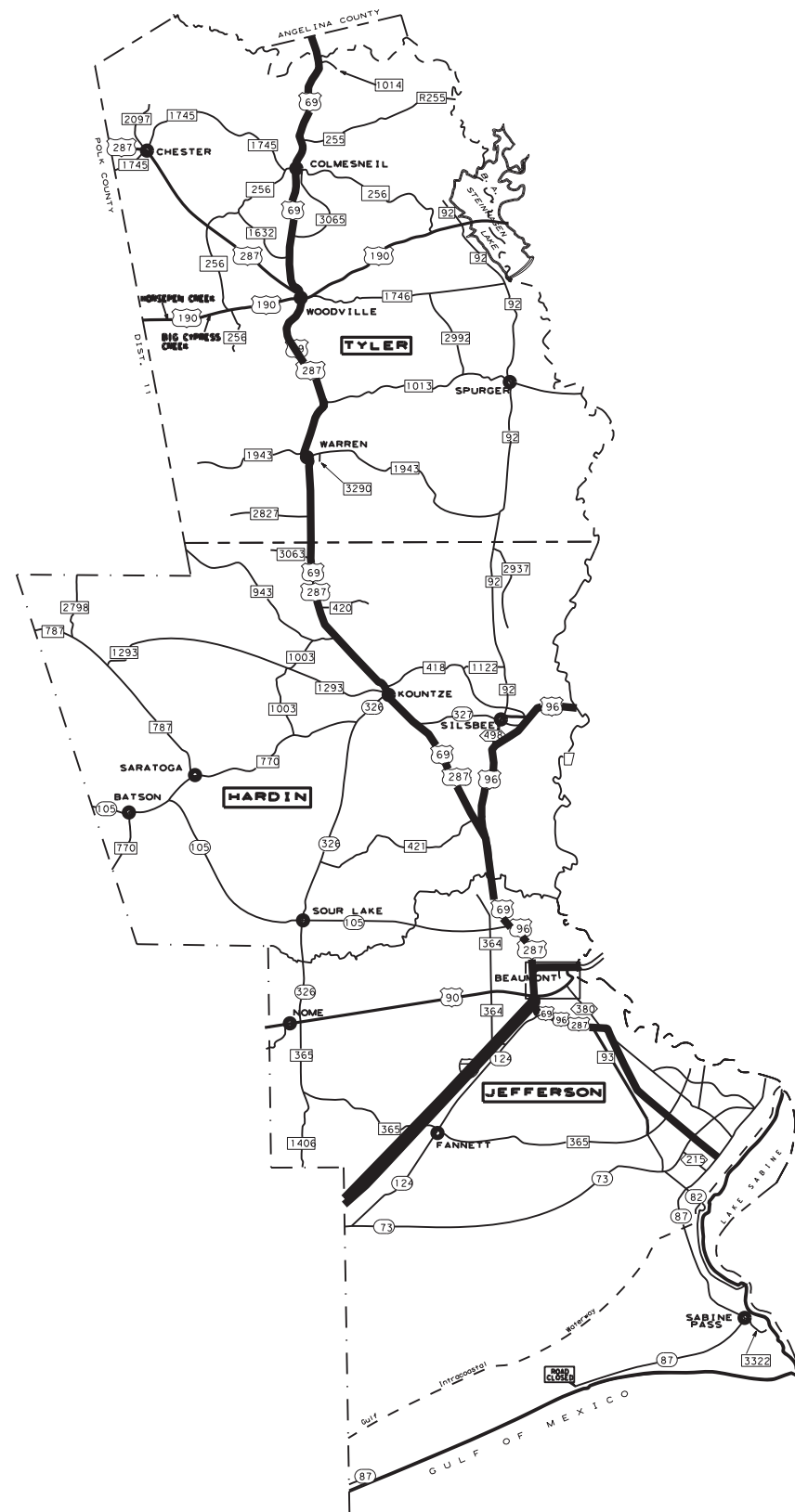
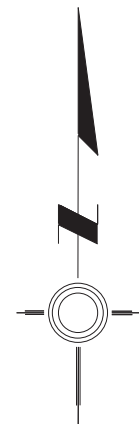

THIS IS AN ON-CALL GUARDRAIL REPAIR PROJECT.  
SPECIFIC WORK SITE LOCATIONS WILL BE  
DETERMINED LATER BY THE ENGINEER.

**NOTES:**

LIMITS SHOWN ON THE PLANS ARE APPROXIMATE.  
ACTUAL REPAIR LOCATIONS WILL BE IDENTIFIED  
BY THE ENGINEER. DO NOT PERFORM REPAIRS  
TO ANY LOCATION UNLESS FIRST APPROVED BY  
THE ENGINEER.

PROJECT COVERS IH10, US69 AND US96.

**CONTACT LIST**

**BEAUMONT MAINTENANCE 02**

BEAUMONT MAINTENANCE SUPERVISOR  
KEVIN EMERSON  
(409) 924-6522

**CONTACT LIST**

**WOODVILLE MAINTENANCE 03**

TYLER MAINTENANCE SUPERVISOR  
JAY CASTLEBERRY  
(409) 283-2451

**CONTACT LIST**

**PORT ARTHUR MAINTENANCE 08**

PORT ARTHUR MAINTENANCE SUPERVISOR  
CARL RAY  
(409) 332-5875

**CONTACT LIST**

**KOUNTZE MAINTENANCE 09**

KOUNTZE MAINTENANCE SUPERVISOR  
STEVEN SINGLETON  
(409) 246-2300

**MBGF  
LOCATION  
MAP**



FHWA		SHEET	
TEXAS		NO.	
DIVISION		3	
STATE	DISTRICT	COUNTY	
TEXAS	BMT	JEFFERSON, etc	
CONTROL	SECTION	JOB	HIGHWAY NO.
6435	38	001	IH10, etc

N.T.S



THIS IS AN ON-CALL CABLE BARRIER REPAIR AND INSTALLATION PROJECT. SPECIFIC WORK SITE LOCATIONS WILL BE DETERMINED LATER BY THE ENGINEER. LOCATIONS ARE APPROXIMATE & ARE SUBJECT TO CHANGE.

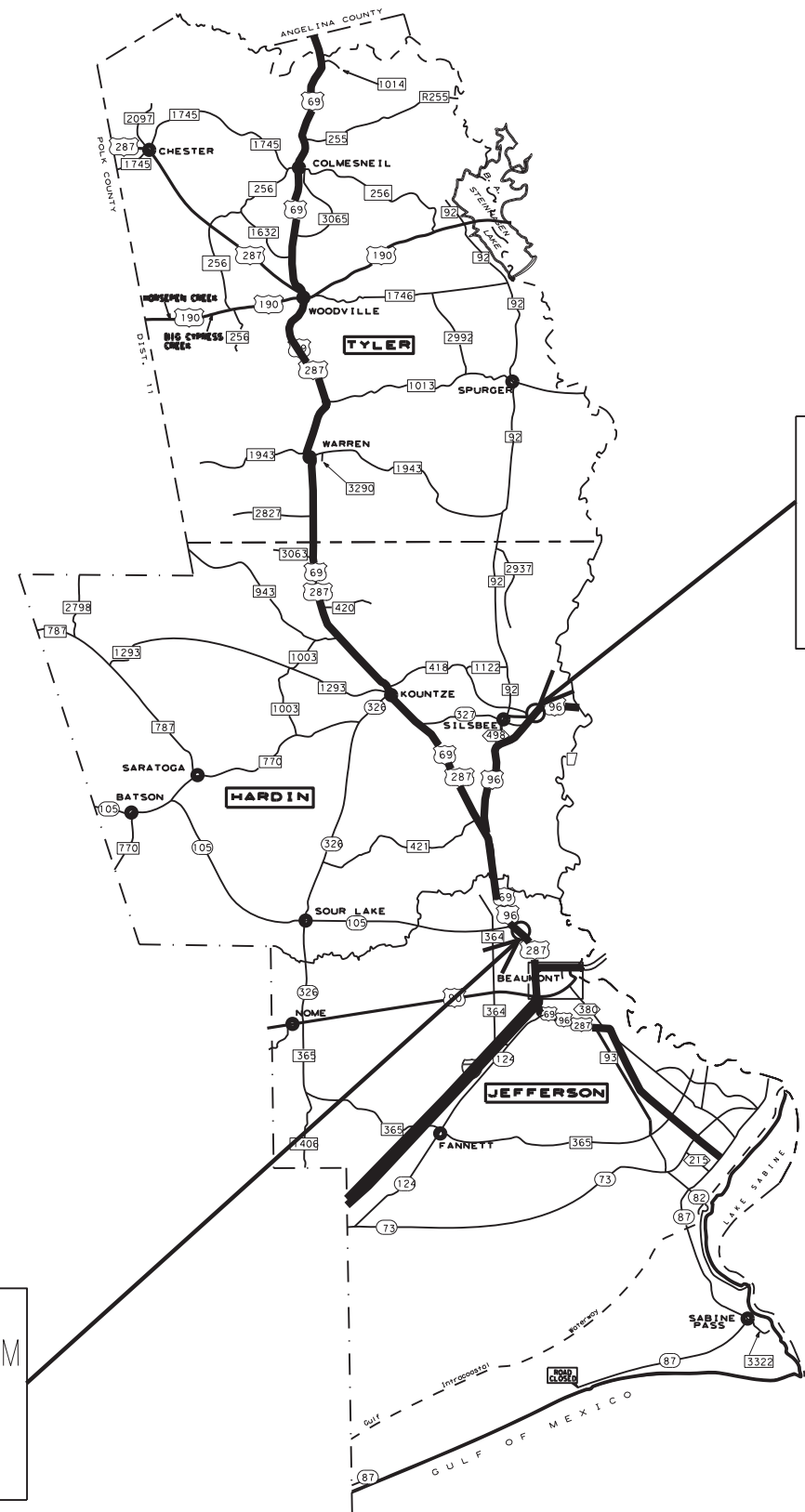

US 96  
 RM 438+0.608 MI TO  
 RM 452+1.197 MI  
 TL-4 SYSTEM  
 REF CSJ: 0065-05-138

US 69  
 RM 522+0.437 MI TO RM  
 522+0.737 MI  
 TL-4 SYSTEM  
 REF CSJ: 0200-11-089

**CABLE BARRIER LOCATION MAP**

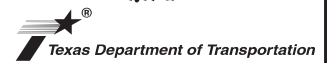

FED. RD. DIV. NO.	MAINTENANCE PROJECT NO.	SHEET NO.
6		4
STATE	DIST.	COUNTY
TEXAS	BMT	JEFFERSON, etc
CONT.	SECT.	JOB HIGHWAY NO.
6435	38	001 IH10, etc

N.T.S

**Project Number: RMC 643538001****Control: 6435-38-001****County: Jefferson, etc.  
Highway: IH10, etc.****General:**

This project includes plans, which are not part of the bid proposal. Plans may be viewed online or downloaded from the website at:

[http://www.txdot.gov/business/contractors\\_consultants/plans\\_online.htm](http://www.txdot.gov/business/contractors_consultants/plans_online.htm)

Plans may be ordered from any of the plan reproduction companies shown on the web at:

[http://www.txdot.gov/business/contractors\\_consultants/repro\\_companies.htm](http://www.txdot.gov/business/contractors_consultants/repro_companies.htm)

Supervision: The Engineer listed below is in charge of the inspection of all work in this Contract. The pre-construction meeting will be scheduled by this office and all requests for payment will be certified by this office.

Contractor questions on this project are to be directed to the following individuals:

Dave Collins, P.E., Beaumont Area Engineer, [Dave.Collins@txdot.gov](mailto:Dave.Collins@txdot.gov)

Taylor Kane, P.E., Beaumont Asst. Area Engineer, [Taylor.Kane@txdot.gov](mailto:Taylor.Kane@txdot.gov)

Questions may be submitted via the Letting Pre-Bid Q&A web page. This webpage can be accessed from the Notice to Contractors dashboard located at the following Address:

<https://tableau.txdot.gov/views/ProjectInformationDashboard/NoticetoContractors>

All Contractor questions will be reviewed by the Engineer. All questions and any corresponding responses that are generated will be posted through the same Letting Pre-Bid Q&A web page.

The Letting Pre-Bid Q&A web page for each project can be accessed by using the dashboard to navigate to the project you are interested in by scrolling or filtering the dashboard using the controls on the left. Hover over the blue hyperlink for the project you want to view the Q&A for and click on the link in the window that pops up.

Before beginning work, the Contractor is required to attend a preconstruction meeting in the office of the Beaumont Area Engineer.

8450 Eastex Frwy  
Beaumont, Texas 77708  
(409)924-6521

The purpose of this Contract is to have a Contractor on-call to repair damaged or upgrade existing metal beam guard fence, median cable barrier, and all related components as directed.

**Project Number: RMC 643538001****Control: 6435-38-001****County: Jefferson, etc.  
Highway: IH10, etc.**

The worksite locations may occur anywhere along IH10, US69 and US96, within Jefferson, Tyler, and Hardin Counties.

Quantities shown on the plans are not to be considered accurate but rather to be used to establish unit prices for bid Items. Some Items listed on the estimate may not be used at all depending on type of damage that occurs at each worksite. Overruns and underruns may occur on any bid Item and will not constitute a "significant change" in the character of work as defined in Article 4.4 of the 2014 Standard Specifications for Construction and Maintenance of Highways, Streets and Bridges. No adjustments will be made as a result of bid Item quantity changes.

Contractor is expected to maintain enough quantities on hand of materials necessary to perform the work. Lack of materials will not be enough of a reason for not completing work orders on time.

In cases where existing landscape shrubs located adjacent to the MBGF and Median Cable Barrier conflict with construction, remove those shrubs necessary to facilitate construction as directed. This work will not be paid for directly, but will be considered subsidiary to pertinent bid Items.

Allow State, city and utility forces to enter this project to accomplish such work as deemed necessary.

Verify material quantities and dimensions before ordering materials.

Place no construction signs in conflict with existing signs. If placement of construction signs for Contract blocks existing signs, make adjustments with confirmation from the Engineer.

Law enforcement will be considered for this Contract under the following conditions as directed:

- Work involving controlled access facilities
- Night work operations that create substantial traffic safety risks for workers or road users
- Major traffic shifts involving high speed (greater than 55 MPH) and high-volume roadways (ADT exceeds 10,000)
- Traffic shifts at intersections where unexpected or sudden queuing is anticipated
- Complex intersections where flaggers may not be able to maintain adequate traffic control

Provide one full-time off-duty uniformed officer, with transportation jurisdiction and full police powers in the county or city in which the project is located, during construction as directed. The

**Project Number: RMC 643538001****Control: 6435-38-001****County: Jefferson, etc.  
Highway: IH10, etc.**

officer must be able to show proof of certification by the Texas Commission on Law Enforcement Officers Standards. Coordinate with local law enforcement and arrange for law enforcement as directed or agreed. Complete the daily tracking form provided by the Department and submit invoices that agree with the tracking form for payment at the end of each month approved services were provided. Peace Officer will be paid by force account, and must be approved.

The vehicle used must be a marked law enforcement vehicle in the city or county where the project is located.

**Item 3: Award and Execution of Contract**

**This Contract includes non-site specific work. Multiple Work Orders will be used to procure work of the type identified in the Contract at locations that have not yet been determined. Time requirements for each non-site specific Work Order will be as defined as noted under Item 8. Once work has begun on a location, continue work until the Work Order is completed.**

Perform work only as directed by a Work Order. Any work performed at locations not covered by a Work Order will not be paid for.

**Item 7: Legal Relations and Responsibilities**

Ingress and egress to the adjacent property will be maintained by the Contractor at all times.

Furnish all materials, labor and incidentals required to provide for traffic across the highway and for temporary ingress and egress to private property at no additional cost to the State. Consider this work to be subsidiary to the pertinent bid Items of the Contract.

No work will be performed within 50' of the nearest track of any railroad crossing.

Work zone enhancements to improve the effectiveness of the Traffic Control Plan that could not be foreseen in the project planning and design stage will be paid for in accordance with Article 9.7, "Payment for Extra Work and Force Account Method". These enhancements will be mutually agreed and based on weekly or more frequent traffic management reviews on the project. The Engineer may choose to use existing bid Items if it does not slow the implementation of enhancement.

**Project Number: RMC 643538001****Control: 6435-38-001****County: Jefferson, etc.  
Highway: IH10, etc.****Item 8: Prosecution and Progress**

**No work will begin on the project before September 1, 2023. Payment for material on hand (MOH) will not be made until after September 1, 2023.**

**"Project" working days will be charged as per Section 8.3.1.5 - Calendar Days. No work will be allowed on Sundays, unless approved.**

**For "Work Order" working days, work will be charged as per Section 8.3.3.2.1, Standard Workweek.**

**A Work Order will consist of a maximum of five site locations.**

Compute and charge working days in accordance with Section 8.3.3.2.1, Standard Workweek Nighttime Work Only with the work hours defined as follows:

- Sunday night at 8:00 p.m. to Monday morning at 6:00 a.m.
- Monday night at 8:00 p.m. to Tuesday morning at 6:00 a.m.
- Tuesday night at 8:00 p.m. to Wednesday morning at 6:00 a.m.
- Wednesday night at 8:00 p.m. to Thursday morning at 6:00 a.m.
- Thursday night at 8:00 p.m. to Friday morning at 6:00 a.m.

Work hour limitations may be modified when approved.

The Engineer or the Department's designated representative will notify the Contractor in writing to begin initial operations. The Engineer will notify the Contractor by email and phone for each Work Order detailing the locations of the work to be performed. Begin work within 72 hours of electronic notification and continue until all work within the respective Work Order is complete.

Within each written Work Order notice, the Contractor will be given the amount of work to be performed, and the date when time charges will begin. A minimum of \$500 of work per Work Order will be scheduled for repair or upgrading before the Contractor is notified to begin work. If the remaining work to be performed to complete the project is less than the minimum Callout amount, the Contractor will still be required to move in and perform the remaining work on the Contract if requested.

The Contractor will mobilize to begin work for each Work Order within 3 days of the submission date of the electronic notification. It will be the Contractor's responsibility to check emails daily for Work Order submissions if phone contact cannot be made. The Contractor will complete all repairs for each Work Order within 7 working days after the 3 day submission period expires. If all work for a Work Order submission is not completed within 10 days, liquidated damages will be incurred thereafter at a rate of \$610 per day until all repairs have been satisfactorily completed. Note that the 10 day completion window consists of 10 working days.

**Project Number: RMC 643538001****Control: 6435-38-001****County: Jefferson, etc.  
Highway: IH10, etc.**

No credit days will be given to this time limit. It will be the responsibility of the Contractor to schedule his work so that all Work Orders can be completed with the 10 working days. If the Engineer determines that the repair is a serious concern for public safety, it will be treated as an emergency repair. The Contractor may be notified and required to make the repairs with less than the \$500 minimum required for normal Work Orders. In such instances, the Contractor will be required to complete repairs within 48 hours of the notification. If emergency repairs are not completed within 48 hours, liquidated damages will be charged in accordance with SP000-1243 for each day the work is not complete. Column protection, Guardrail End Treatment repairs, & Crash Cushion Attenuator repairs are examples of safety concerns with no minimum work limits.

Notify the Engineer by 3:00 p.m. the preceding day before proceeding with planned work activities, including lane closures. For Sunday and Monday night work, notification will need to be received by 3:00 p.m. on the Friday before work can proceed. Work will not be permitted if such notification has not been received. In addition, work performed without authorization will not be eligible for payment. The Engineer will be notified any time that work will not be performed by 8:15 A.M. of that day.

The Contractor will be responsible for making all arrangements for equipment and storage areas. No storage of equipment and materials will be permitted at Maintenance Section yards, District Office, or highway right of way.

The Contractor must maintain a fluent English-speaking person or have an answering system to answer the telephone between the hours of 8:00 am and 5:00 pm Monday through Friday. It is the Contractor's responsibility to keep the Engineer notified of the correct telephone number.

For the duration of this Contract, any idle time including time between notifications will not be paid for directly but will be considered subsidiary to the pertinent bid Items in this Contract.

Ensure enough workers, equipment and materials are available at all worksites to continuously and diligently prosecute the work to conclusion. Insufficient resources resulting in poor performance may be grounds for default.

The Contractor will be expected to provide enough crews to work on multiple Work Orders simultaneously.

Adjoining projects may be in progress during the construction of a portion of this project. Plan and prosecute the sequence of construction and the traffic control plan with adjacent construction projects, if applicable. Manage construction of all phases to minimize disruption to traffic.

**Project Number: RMC 643538001****Control: 6435-38-001****County: Jefferson, etc.  
Highway: IH10, etc.****Item 104: Removing Concrete**

Limits of riprap and mow strip removal will be as directed.

**Item 432: Riprap**

Use Class B concrete to repair concrete mow strips.

Repair mow strips as per details on standard sheets MBGF(MS)-19 or GF(31)MS-19, depending which one is applicable.

Limit of mow strip repair will be determined as per STATE Standard MBGF(MS)-19 or GF(31)MS-19, as directed.

**Item 500: Mobilization**

The work of this Contract is intermittent and not continuous. The Contractor will expect multiple mobilizations (move-ins) for the duration of this Contract.

Mobilization will be paid for each Work Order issued.

**Item 502: Barricades, Signs and Traffic Handling**

Work zone rumble strips will be used on all short duration and short term stationary lane closures. Work zone rumble strips will not be required on access controlled facilities.

Furnish and maintain all barricades and warning signs, including all temporary and portable traffic control devices necessary to complete construction.

Construct and place in accordance with the barricades and construction standards, latest Texas MUTCD, and the traffic control plans, or as directed. THIS WORK WILL NOT BE PAID FOR DIRECTLY, BUT WILL BE CONSIDERED SUBSIDIARY TO PERTINENT BID ITEMS. Lane closures will be required when work is being performed within 10' of the edge of pavement.

All travel lanes will be opened to traffic by the end of the defined workday for that location. Arrange work so that no machinery or equipment will be closer than 30' to the roadway after sunset unless authorized in writing.

**Project Number: RMC 643538001****Control: 6435-38-001****County: Jefferson, etc.**  
**Highway: IH10, etc.**

Plan work sequence in a manner that will cause the minimum interference with traffic during construction operations.

If at any time during the construction, the proposed plan of operation for handling traffic does not provide for safe and comfortable movement, immediately change operations to correct the unsatisfactory condition.

The use of an orange reflectorized safety vest and a white safety hat will be required by persons performing flagging operations and each person will be properly instructed in flagging procedures.

Shadow vehicles with certified Truck Mounted Attenuators (TMA) will be required as per TCP Standard Sheets as directed.

Work will not be permitted on both sides of the roadway at the same time.

**Item 506: Temporary Erosion, Sedimentation, and Environmental Controls**

It is not anticipated that any erosion, sedimentation, or environmental control devices will be needed on this project. If such controls are necessary, the SW3P for this project will consist of the use of any temporary erosion control measures deemed necessary. Payment for the work will be determined in accordance with Article 9.7, "Payment for Extra Work and Force Account Method".

**Item 540: Metal Beam Guard Fence**

Furnish and install new metal beam guard fence in accordance with standards on the plans.

Guard Rail Adjustment work includes vertical adjustment of the rail element to upgrade rail to the standard height. Adjustment may require new holes in existing posts. Drilling new holes WILL be considered subsidiary to Item 540.

Complete all repairs as directed. Use bid Items determined to be the most cost effective to the State.

The length of MBGF at any location may be increased or decreased as directed. Furnish and install block-outs between the rail elements and the timber posts as detailed on the plans. These block-outs will not be paid for directly, but will be considered subsidiary to this Item.

Use domed timber posts for the metal beam guard fence as directed.

**Project Number: RMC 643538001****Control: 6435-38-001****County: Jefferson, etc.**  
**Highway: IH10, etc.**

Construction of all MBGF will proceed in the direction of traffic. At the end of each work day, protect any blunt ends remaining after work hours with a Truck Mounted Attenuator until the guardrail end treatment has been installed. This work will be subsidiary.

GF(31)-19, GF(31)DAT-19, GF(31)LS-19, GF(31)TRTL3-20, GF(31)T101-19, GF(31)T6-19, GF(31)MS-19, SGT(10S)31-16, SGT(11S)31-18, SGT(12S)31-18 & BED-14 standards will be used on upgrades unless otherwise directed.

**Item 542: Removing Metal Beam Guard Fence**

Remove any Terminal Anchor Sections when directed regardless if they have sustained damage or not.

When "Removing Terminal Anchor Section" a section consists of a terminal anchor post and one 25-ft rail element. Completely remove posts and any concrete surrounding the posts.

**Item 544: Guardrail End Treatments**

Damage to any portion of an ET-2000 or ET-Plus SGT system (damage within 50' of the SGT head) will not be repaired but will be replaced in its entirety with a new approved MASH Compliant SGT system.

**Item 545: Crash Cushion Attenuators**

The 6" reinforced concrete foundation, embankment and preparation for the concrete slab are to be considered subsidiary to this Item.

**Item 658: Delineator and Object Marker Assemblies**

Install delineators when directed. This may require installation of delineators on portions of guardrail and bridge rail that is not being repaired to maintain consistency with adjacent sections.

MBGF will receive Type C GF2 delineators installed on 100' maximum spacing.

Type C delineators will be installed using Adhesive 795A manufactured by Davidson Traffic Control Products or an equivalent approved in writing.



**Project Number: RMC 643538001****Control: 6435-38-001****County: Jefferson, etc.  
Highway: IH10, etc.****Item 770: Guard Fence Repair**

Repair standards will match the design of the existing metal beam guard fence regarding guardrail height, 28" or 31" unless otherwise directed. In the scenario of a total demolition of a system including the SGT and all guardrail up to the bridge rail, replace with 31" height components.

Any necessary repairs to old design systems not detailed on the plans will be repaired using the most current design detailed on the plans as directed.  
Furnish all materials for this Item.  
Complete all repairs as directed. Use bid Items determined to be the most cost effective to the State.

Minor amounts of tree trimming and underbrush removal may be needed to perform the work. This work will not be paid for directly but will be considered subsidiary to Item 770.

Any work required to remove and reattach sections of rail and S.G.T.'s adjacent to the damaged rail will be considered subsidiary to this Item.

All bridge rail consisting of "W" rail sections connected to the top rail or concrete rail will be paid for under the bid Item "Repair Rail Element (W-Beam)".

All back-up plates and any other incidentals necessary to repair metal beam guard fence will not be paid for directly but will be considered subsidiary to this Item.

Drilling new postholes and backfilling old post holes to repair metal beam guard fence will not be paid for directly but will be considered subsidiary to this Item.

All required epoxy-grouted work will be considered subsidiary to this Item.

Furnish rail elements that match rail elements being replaced.

If any damaged MBGF consists of existing steel posts, these posts will be replaced with timber posts without concrete foundations except when steel posts are required to cross box culverts, etc. This work will be paid for under Items 770-6010 and 770-6011.

Replace posts to their original heights or as specified and backfill with debris-free soil and tamp in place. Repair damaged metal posts as directed or when directed, replace with wood posts.

When the guard fence does not have a mow strip, compact backfilled soil around timber and steel posts with a mechanical tamping device capable of accomplishing the work.

**Project Number: RMC 643538001****Control: 6435-38-001****County: Jefferson, etc.  
Highway: IH10, etc.**

When the guard fence is located within an asphalt or concrete mow strip, replace material around the post with a two sack grout in accordance with Section 421.2.7 and as shown on standard sheet MBGF(MS)-19 or GF(31)MS-19. This work will not be paid for directly, but will be subsidiary to other bid Items.

Dig holes the diameter and depth shown on the plans with an auger capable of accomplishing the work.

All holes drilled for guardrail connections to any concrete structure (wingwalls, etc.) will be subsidiary to the various bid Items. This includes holes required when raising or upgrading guardrail.

Take possession of all unsalvageable metal beam guard fence rail elements and posts and remove from the project the same day.

When directed, furnish and install wood or composite blocks on existing guardrail that have steel block-outs. This work will be paid for under Item 770-6019.

Either wood or composite blocks for guardrail may be used but only one type will be used per location. Wood and composite blocks will not be mixed within a run of guardrail.

Object Markers placed on the front face of the SGT head will not be paid for directly but will be considered subsidiary to this bid Item.

If a Single Guardrail Terminal is completely demolished, replace the entire unit under Item 770-6027 when directed. The removal of the existing system will not be paid for directly, but will be considered subsidiary to this Item.

Provide Type III SGT's for all SGT's that are installed or replaced on the project.

Payment will not be made for any repair work until the damaged location is completely restored to proper condition.

**Item 771: Repair Cable Barrier System**

Replacement of miscellaneous components such as plastic spacers, delineators, etc. will not be paid for directly but will be considered subsidiary to this bid Item. This work will be performed as directed. This work may be required on adjacent posts that did not require replacement but were affected by the accident that caused the primary damage.

**Payment will not be made for any repair work until the damaged location is completely restored to proper condition, including re-tensioning of the cables when directed.**

**Project Number: RMC 643538001****Control: 6435-38-001****Project Number: RMC 643538001****Control: 6435-38-001****County: Jefferson, etc.  
Highway: IH10, etc.****County: Jefferson, etc.  
Highway: IH10, etc.**

The determination of the repair or replacement of any cable barrier components will be as directed. The extent of repairs will be as directed.

Repairs may be required on various types and versions of cable barrier systems. Contractor will verify proper type and version of system before repairs are made. Standard installation sheets for each anticipated system are included on the plans for reference.

Check and Re-Tension Cable when directed. This Item will include resetting cables into proper position before tensioning. Resetting cables into proper position will be considered subsidiary to this bid Item.

**Item 774: Attenuator Repair**

When damaged **NON-MASH** compliant Crash Cushion Attenuators are encountered they will not be repaired. Contractor will remove and replace with the appropriate sized MASH approved Crash Cushion for the area. This work will be paid for under Items, 774-6014, 774-6016, 774-6041, 774-6042, 774-6125 or 774-6126. The Engineer will choose the appropriate Crash Cushion for the area.

Repairs that are paid for by the cylinder or by the bay will include all necessary components needed for constructing a complete cylinder or bay. The realignment and adjustments of other cylinders or bays will not be paid for directly but will be considered subsidiary.

**Item 6001: Portable Changeable Message Sign**

Portable changeable message signs (PCMS) will be used when directed.

Message on the sign will be as shown on the pertinent Traffic Control Plan or as directed.

Provide screen type "Continuous Line Matrix".

More than one PCMS may be required on this project. Payment for PCMS's will be per day used and for each sign used.

When possible, PCMS units should be located in advance of the last available alternate route before the lane closure. They may also be relocated to improve advance warning in case of unanticipated queuing or congestion.

**Item 6185: Truck Mounted Attenuator (TMA) and Trailer Attenuator (TA)**

In addition to the shadow vehicles with truck mounted attenuator (TMA) that are specified as being required on the traffic control plan for this project, provide additional shadow vehicles with TMA, therefore 1 total shadow vehicle with TMA will be required for this type of work. The Contractor will be responsible for determining if one or more of these operations will be ongoing at the same time to determine the total number of TMAs needed for this project.



# Estimate & Quantity Sheet

CONTROLLING PROJECT ID 6435-38-001

DISTRICT Beaumont

COUNTY Jefferson

HIGHWAY IH0010

CONTROL SECTION JOB				6435-38-001		TOTAL EST.	TOTAL FINAL
PROJECT ID				A00194154			
COUNTY				Jefferson			
HIGHWAY				IH0010			
ALT	BID CODE	DESCRIPTION	UNIT	EST.	FINAL		
	104-6009	REMOVING CONC (RIPRAP)	SY	4.000		4.000	
	429-6011	CONC STR REPR(REMOV AND REPL WINGWALL)	CY	2.000		2.000	
	432-6045	RIPRAP (MOW STRIP)(4 IN)	CY	9.000		9.000	
	451-6004	RETROFIT RAIL (TY T131RC)	LF	115.000		115.000	
	500-6033	MOBILIZATION (CALLOUT)	EA	113.000		113.000	
	500-6034	MOBILIZATION (EMERGENCY)	EA	5.000		5.000	
	540-6001	MTL W-BEAM GD FEN (TIM POST)	LF	8.000		8.000	
	540-6003	MTL THRIE-BEAM GD FEN (TIM POST)	LF	4.000		4.000	
	540-6006	MTL BEAM GD FEN TRANS (THRIE-BEAM)	EA	1.000		1.000	
	540-6007	MTL BEAM GD FEN TRANS (TL2)	EA	2.000		2.000	
	540-6008	MTL BEAM GD FEN TRANS (T101)	EA	1.000		1.000	
	540-6009	MTL BEAM GD FEN TRANS (T6)	EA	1.000		1.000	
	540-6010	MTL W-BEAM GD FEN ADJUSTMENT	LF	1.000		1.000	
	540-6011	MTL THRIE-BEAM GD FEN ADJUSTMENT	LF	1.000		1.000	
	540-6012	TERMINAL ANCHOR SECTION ADJUSTMENT	EA	1.000		1.000	
	540-6013	TRANSITION ADJUSTMENT	EA	2.000		2.000	
	540-6016	DOWNSTREAM ANCHOR TERMINAL SECTION	EA	2.000		2.000	
	540-6017	MTL BM GD FEN (LONG SPAN SYSTEM)	LF	4.000		4.000	
	540-6035	MTL BM GD FEN TRANS (31"-28")	EA	1.000		1.000	
	542-6001	REMOVE METAL BEAM GUARD FENCE	LF	40.000		40.000	
	542-6002	REMOVE TERMINAL ANCHOR SECTION	EA	4.000		4.000	
	544-6002	GUARDRAIL END TREATMENT (MOVE & RESET)	EA	2.000		2.000	
	544-6003	GUARDRAIL END TREATMENT (REMOVE)	EA	2.000		2.000	
	544-6008	GUARDRAIL END TRTMNT(RETRO)(STEEL POST)	EA	1.000		1.000	
	544-6009	GUARDRAIL END TRTMNT(RETRO)(WOOD POST)	EA	1.000		1.000	
	544-6010	GDRL END TRMT(RETRO W/O HEAD)(STL POST)	EA	1.000		1.000	
	544-6011	GDRL END TRMT(RETRO W/O HEAD)(WD POST)	EA	1.000		1.000	
	545-6005	CRASH CUSH ATTEN (REMOVE)	EA	1.000		1.000	
	545-6013	CRASH CUSH ATTEN (INSTL)(R)(N)(TL3)	EA	1.000		1.000	
	545-6025	CRASH CUSHION ATTEN (INSTALL)(REACT)(N)	EA	1.000		1.000	
	658-6015	INSTL DEL ASSM (D-SW)SZ (BRF)GF1	EA	4.000		4.000	
	658-6016	INSTL DEL ASSM (D-SW)SZ (BRF)GF1 (BI)	EA	4.000		4.000	
	658-6028	INSTL DEL ASSM (D-SY)SZ (BRF)GF1	EA	35.000		35.000	
	658-6062	INSTL DEL ASSM (D-SW)SZ 1(BRF)GF2(BI)	EA	9.000		9.000	
	658-6063	INSTL DEL ASSM (D-SW)SZ 1(BRF)GF2(BR)	EA	2.000		2.000	
	770-6001	REPAIR RAIL ELEMENT (W - BEAM)	LF	3,750.000		3,750.000	
	770-6002	REPAIR RAIL ELEMENT (THRIE - BEAM)	LF	1.000		1.000	



CONTROLLING PROJECT ID 6435-38-001

DISTRICT Beaumont  
HIGHWAY IH0010

COUNTY Jefferson

# Estimate & Quantity Sheet

CONTROL SECTION JOB				6435-38-001		TOTAL EST.	TOTAL FINAL
PROJECT ID				A00194154			
COUNTY				Jefferson			
HIGHWAY				IH0010			
ALT	BID CODE	DESCRIPTION	UNIT	EST.	FINAL		
	770-6003	REP RAIL ELMNT(THRIE-BM TRANS TO W -BM)	LF	8.000		8.000	
	770-6004	REPAIR RAIL ELEMENT (CURVED RAIL)	LF	8.000		8.000	
	770-6010	REM / REPL TIMBER/STL POST W/O CONC FND	EA	75.000		75.000	
	770-6011	REM / REPL TIMBER / STL POST W/CONC FND	EA	38.000		38.000	
	770-6015	REM / REPL STEEL POST W / CONC FND	EA	4.000		4.000	
	770-6016	REPAIR STEEL POST WITH BASE PLATE	EA	6.000		6.000	
	770-6017	REALIGN POSTS	EA	750.000		750.000	
	770-6019	REMOVE & REPLACE BLOCKOUT	EA	150.000		150.000	
	770-6021	REPLACE SINGLE GDRAIL TERMINAL RAIL	LF	750.000		750.000	
	770-6022	REPLACE SINGLE GDRAIL TERMINAL POST	EA	132.000		132.000	
	770-6023	REPAIR OF TERMINAL ANCHORS POSTS	EA	4.000		4.000	
	770-6024	REPLACE TERMINAL ANCHOR POSTS	EA	4.000		4.000	
	770-6027	REMOVE GDRAIL END TRT / REPL WITH SGT	EA	12.000		12.000	
	770-6028	REPL SINGLE GDRAIL TERM IMPACT HEAD	EA	23.000		23.000	
	770-6029	REM & RESET SGT IMPACT HEAD	EA	8.000		8.000	
	770-6030	REPLACE SGT CABLE ASSEMBLY	EA	23.000		23.000	
	770-6032	REPLACE SGT STRUT	EA	23.000		23.000	
	770-6033	REPLACE SGT OBJECT MARKER	EA	15.000		15.000	
	770-6052	REPAIR STEEL POST WITH BASE PLATE	EA	1.000		1.000	
	770-6058	REPAIR (SMTC)(N)(BAY)	EA	4.000		4.000	
	771-6002	REPLACE POSTS (TL-4)	EA	578.000		578.000	
	771-6004	CABLE SPLICE / TURNBUCKLE (TL-4)	EA	8.000		8.000	
	771-6006	REPAIR CONCRETE FOUNDATION (TL-4)	EA	2.000		2.000	
	771-6008	REPR OR REPLC CABLE BARR TERM SEC(TL-4)	EA	15.000		15.000	
	771-6010	REPLACE CABLE (TL-4)	LF	150.000		150.000	
	771-6011	CHECK / RE-TENSION CABLE	EA	30.000		30.000	
	771-6014	REPLACE POSTS (TL-4)(FURN)	EA	19.000		19.000	
	774-6010	REPAIR (REACT)	EA	1.000		1.000	
	774-6014	REMOVE AND REPLACE (NARROW QUAD)	EA	1.000		1.000	
	774-6015	REPAIR (NARROW QUAD)	EA	1.000		1.000	
	774-6016	REMOVE AND REPLACE (WIDE QUAD)	EA	1.000		1.000	
	774-6017	REPAIR (WIDE QUAD)	EA	1.000		1.000	
	774-6023	REPAIR REACT (N) (MISC HARDWARE)	EA	1.000		1.000	
	774-6024	REPAIR REACT (N) (REAR SEC "S")	EA	1.000		1.000	
	774-6025	REPAIR REACT (N) (REAR SEC "B")	EA	1.000		1.000	
	774-6026	REPAIR REACT (N) (FRONT SECTION)	EA	1.000		1.000	
	774-6027	REPAIR REACT (N) (CYLINDERS)	EA	1.000		1.000	

DISTRICT	COUNTY	CCSJ	SHEET
Beaumont	Jefferson	6435-38-001	12



CONTROLLING PROJECT ID 6435-38-001

DISTRICT Beaumont

COUNTY Jefferson

HIGHWAY IH0010

# Estimate & Quantity Sheet

CONTROL SECTION JOB				6435-38-001		TOTAL EST.	TOTAL FINAL
PROJECT ID				A00194154			
COUNTY				Jefferson			
HIGHWAY				IH0010			
ALT	BID CODE	DESCRIPTION	UNIT	EST.	FINAL		
	774-6028	REPAIR (QUAD) (N) (BAY)	EA	1.000		1.000	
	774-6029	REPAIR (QUAD) (W) (BAY)	EA	1.000		1.000	
	774-6034	REPAIR REACT (MISC) (HARDWARE)	EA	1.000		1.000	
	774-6035	REPAIR REACT (CYLINDERS)	EA	1.000		1.000	
	774-6039	REPAIR (QUAD - ELITE) NARROW (BAY)	EA	4.000		4.000	
	774-6040	REPAIR (QUAD - ELITE) WIDE (BAY)	EA	1.000		1.000	
	774-6041	REMOVE / REPLACE (QUAD - ELITE) NARROW	EA	1.000		1.000	
	774-6042	REMOVE / REPLACE (QUAD - ELITE) WIDE	EA	1.000		1.000	
	774-6043	REPAIR (QUADGUARD - ELITE) (CYLINDER)	EA	1.000		1.000	
	774-6073	REPAIR (QUAD) (N) (NOSE)	EA	1.000		1.000	
	774-6074	REPAIR (QUAD) (W) (NOSE)	EA	1.000		1.000	
	774-6076	REPAIR QUAD (W) (MISC HARDWARE)	EA	1.000		1.000	
	774-6083	QUAD(N)(BAY)CARTRIDGE(REMOVE & REPLACE)	EA	1.000		1.000	
	774-6084	QUAD(N)(BAY)NOSE ASSMBLY (REMOVE&REPLAC)	EA	1.000		1.000	
	774-6085	QUAD(N)(BAY)DIAPHRAGM(REMOVE & REPLACE)	EA	1.000		1.000	
	774-6086	QUAD(W)(BAY)CARTRIDGE(REMOVE & REPLACE)	EA	1.000		1.000	
	774-6087	QUAD(W)(BAY)NOSE ASSMBLY (REMOVE&REPLAC)	EA	1.000		1.000	
	774-6088	QUAD(W)(BAY)DIAPHRAGM(REMOVE & REPLACE)	EA	1.000		1.000	
	774-6101	QUAD FENDER PANEL	EA	1.000		1.000	
	774-6103	REACT DECAL	EA	1.000		1.000	
	774-6117	REMOVE AND REPLACE (QUADGUARD)(MASH) (N)	EA	1.000		1.000	
	774-6118	REPAIR (QUADGUARD)(MASH)(N)	EA	1.000		1.000	
	774-6119	REPAIR (QUADGUARD)(MASH)(N)(BAY)	EA	1.000		1.000	
	774-6120	REPAIR (QUADGUARD)(MASH)(N)	LF	30.000		30.000	
	774-6122	REPAIR (TAU)(MASH)(N)	EA	1.000		1.000	
	774-6123	REPAIR (TAU)(MASH)(N)(BAY)	EA	4.000		4.000	
	774-6124	REPAIR (TAU)(MASH)(N)	LF	30.000		30.000	
	774-6125	REMOVE AND REPLACE (QUADGUARD)(M10)(W)	EA	1.000		1.000	
	774-6126	REMOVE AND REPLACE (REACT)(M)(NARROW)	EA	1.000		1.000	
	6001-6001	PORTABLE CHANGEABLE MESSAGE SIGN	DAY	4.000		4.000	
	6185-6002	TMA (STATIONARY)	DAY	113.000		113.000	

CATEGORY OF WORK	Roadway	Roadway	Roadway	Roadway	Roadway	Roadway	Roadway	Roadway	Roadway	Roadway
BID CODE	104-6009	429-6011	432-6045	451-6004	500-6033	500-6034	540-6001	540-6003	540-6006	540-6007
DESCRIPTION	REMOVING CONC (RIPRAP)	CONC STR REPR(REMOV AND REPL WINGWALL)	RIPRAP (MOW STRIP)(4 IN)	RETROFIT RAIL (TY T131RC)	MOBILIZATION (CALLOUT)	MOBILIZATION (EMERGENCY)	MTL W-BEAM GD FEN (TIM POST)	MTL THRIE-BEAM GD FEN (TIM POST)	MTL BEAM GD FEN TRANS (THRIE-BEAM)	MTL BEAM GD FEN TRANS (TL2)
UNIT	SY Square Yards	CY Cubic Yard	CY Cubic Yard	LF Linear Feet	EA Each	EA Each	LF Linear Feet	LF Linear Feet	EA Each	EA Each
<b>PROJECT TOTALS</b>	<b>4</b>	<b>2</b>	<b>9</b>	<b>115</b>	<b>113</b>	<b>5</b>	<b>8</b>	<b>4</b>	<b>1</b>	<b>2</b>

CATEGORY OF WORK	Roadway	Roadway	Roadway	Roadway	Roadway	Roadway	Roadway	Roadway	Roadway	Roadway
BID CODE	540-6008	540-6009	540-6010	540-6011	540-6012	540-6013	540-6016	540-6017	540-6035	542-6001
DESCRIPTION	MTL BEAM GD FEN TRANS (T101)	MTL BEAM GD FEN TRANS (T6)	MTL W-BEAM GD FEN ADJUSTMENT	MTL THRIE-BEAM GD FEN ADJUSTMENT	TERMINAL ANCHOR SECTION ADJUSTMENT	TRANSITION ADJUSTMENT	DOWNSTREAM ANCHOR TERMINAL SECTION	MTL BM GD FEN (LONG SPAN SYSTEM)	MTL BM GD FEN TRANS (31"-28")	REMOVE METAL BEAM GUARD FENCE
UNIT	EA Each	EA Each	LF Linear Feet	LF Linear Feet	EA Each	EA Each	EA Each	LF Linear Feet	EA Each	LF Linear Feet
<b>PROJECT TOTALS</b>	<b>1</b>	<b>1</b>	<b>1</b>	<b>1</b>	<b>1</b>	<b>2</b>	<b>2</b>	<b>4</b>	<b>1</b>	<b>40</b>

CATEGORY OF WORK	Roadway	Roadway	Roadway	Roadway	Roadway	Roadway	Roadway	Roadway	Roadway	Roadway
BID CODE	542-6002	544-6002	544-6003	544-6008	544-6009	544-6010	544-6011	545-6005	545-6013	545-6025
DESCRIPTION	REMOVE TERMINAL ANCHOR SECTION	GUARDRAIL END TREATMENT (MOVE & RESET)	GUARDRAIL END TREATMENT (REMOVE)	GUARDRAIL END TRTMNT(RETRO)(STEEL POST)	GUARDRAIL END TRTMNT(RETRO)(WOOD POST)	GDRL END TRMT(RETRO W/O HEAD)(STL POST)	GDRL END TRTMNT(RETRO W/O HEAD)(WD POST)	CRASH CUSH ATTEN (REMOVE)	CRASH CUSH ATTEN (INSTL)(R)(N)(TL3)	CRASH CUSHION ATTEN (INSTALL)(REACT)(N)
UNIT	EA Each	EA Each	EA Each	EA Each	EA Each	EA Each	EA Each	EA Each	EA Each	EA Each
<b>PROJECT TOTALS</b>	<b>4</b>	<b>2</b>	<b>2</b>	<b>1</b>	<b>1</b>	<b>1</b>	<b>1</b>	<b>1</b>	<b>1</b>	<b>1</b>

CATEGORY OF WORK	Roadway	Roadway	Roadway	Roadway	Roadway	Roadway	Roadway	Roadway	Roadway	Roadway
BID CODE	658-6015	658-6016	658-6028	658-6062	658-6063	770-6001	770-6002	770-6003	770-6004	770-6010
DESCRIPTION	INSTL DEL ASSM (D-SW)SZ (BRF)GF1	INSTL DEL ASSM (D-SW)SZ (BRF)GF1 (BI)	INSTL DEL ASSM (D-SY)SZ (BRF)GF1	INSTL DEL ASSM (D-SW)SZ 1(BRF)GF2(BI)	INSTL DEL ASSM (D-SW)SZ 1(BRF)GF2(BR)	REPAIR RAIL ELEMENT (W - BEAM)	REPAIR RAIL ELEMENT (THRIE - BEAM)	REP RAIL ELMNT(THRIE-BM TRANS TO W-BM)	REPAIR RAIL ELEMENT (CURVED RAIL)	REM / REPL TIMBER/STL POST W/O CONC FND
UNIT	EA Each	EA Each	EA Each	EA Each	EA Each	LF Linear Feet	LF Linear Feet	LF Linear Feet	LF Linear Feet	EA Each
<b>PROJECT TOTALS</b>	<b>4</b>	<b>4</b>	<b>4</b>	<b>9</b>	<b>2</b>	<b>3,750</b>	<b>1</b>	<b>8</b>	<b>8</b>	<b>75</b>

CATEGORY OF WORK	Roadway	Roadway	Roadway	Roadway	Roadway	Roadway	Roadway	Roadway	Roadway	Roadway
BID CODE	770-6011	770-6015	770-6016	770-6017	770-6019	770-6021	770-6022	770-6023	770-6024	770-6027
DESCRIPTION	REM / REPL TIMBER / STL POST W/CONC FND	REM / REPL STEEL POST W / CONC FND	REPAIR STEEL POST WITH BASE PLATE	REALIGN POSTS	REMOVE & REPLACE BLOCKOUT	REPLACE SINGLE GDRAIL TERMINAL RAIL	REPLACE SINGLE GDRAIL TERMINAL POST	REPAIR OF TERMINAL ANCHORS POSTS	REPLACE TERMINAL ANCHOR POSTS	REMOVE GDRAIL END TRT / REPL WITH SGT
UNIT	EA Each	EA Each	EA Each	EA Each	EA Each	LF Linear Feet	EA Each	EA Each	EA Each	EA Each
<b>PROJECT TOTALS</b>	<b>38</b>	<b>4</b>	<b>6</b>	<b>94</b>	<b>150</b>	<b>750</b>	<b>132</b>	<b>4</b>	<b>4</b>	<b>12</b>

**SUMMARY SHEET**

SHEET 1 OF 2



FED. RD. DIV. NO.	MAINTENANCE PROJECT NO.	SHEET NO.	
		14	
STATE	DIST.	COUNTY	
TEXAS	BMT	JEFFERSON, etc	
CONT.	SECT.	JOB	HIGHWAY NO.
6435	38	001	IH10, etc

CATEGORY OF WORK	Roadway	Roadway	Roadway	Roadway	Roadway	Roadway	Roadway	Roadway	Roadway	Roadway
BID CODE	770-6028	770-6029	770-6030	770-6032	770-6033	770-6052	770-6058	771-6002	771-6004	771-6006
DESCRIPTION	REPL SINGLE GDRAIL TERM IMPACT HEAD	REM & RESET SGT IMPACT HEAD	REPLACE SGT CABLE ASSEMBLY	REPLACE SGT STRUT	REPLACE SGT OBJECT MARKER	REPAIR STEEL POST WITH BASE PLATE	REPAIR (SMTC)(N)(BAY)	REPLACE POSTS (TL-4)	CABLE SPLICE / TURNBUCKLE (TL-4)	REPAIR CONCRETE FOUNDATION (TL-4)
UNIT	EA Each	EA Each	EA Each	EA Each	EA Each	EA Each	EA Each	EA Each	EA Each	EA Each
<b>PROJECT TOTALS</b>	<b>23</b>	<b>8</b>	<b>23</b>	<b>23</b>	<b>15</b>	<b>1</b>	<b>4</b>	<b>578</b>	<b>8</b>	<b>2</b>

CATEGORY OF WORK	Roadway	Roadway	Roadway	Roadway	Roadway	Roadway	Roadway	Roadway	Roadway	Roadway
BID CODE	771-6008	771-6010	771-6011	771-6014	774-6010	774-6014	774-6015	774-6016	774-6017	774-6023
DESCRIPTION	REPR OR REPLC CABLE BARR TERM SEC(TL-4)	REPLACE CABLE (TL-4)	CHECK / RE-TENSION CABLE	REPLACE POSTS (TL-4)(FURN)	REPAIR (REACT)	REMOVE AND REPLACE (NARROW QUAD)	REPAIR (NARROW QUAD)	REMOVE AND REPLACE (WIDE QUAD)	REPAIR (WIDE QUAD)	REPAIR REACT (N) (MISC HARDWARE)
UNIT	EA Each	LF Linear Feet	EA Each	EA Each	EA Each	EA Each	EA Each	EA Each	EA Each	EA Each
<b>PROJECT TOTALS</b>	<b>15</b>	<b>750</b>	<b>30</b>	<b>19</b>	<b>1</b>	<b>1</b>	<b>1</b>	<b>1</b>	<b>1</b>	<b>1</b>

CATEGORY OF WORK	Roadway	Roadway	Roadway	Roadway	Roadway	Roadway	Roadway	Roadway	Roadway	Roadway
BID CODE	774-6024	774-6025	774-6026	774-6027	774-6028	774-6029	774-6034	774-6035	774-6039	774-6040
DESCRIPTION	REPAIR REACT (N) (REAR SEC "S")	REPAIR REACT (N) (REAR SEC "B")	REPAIR REACT (N) (FRONT SECTION)	REPAIR REACT (N) (CYLINDERS)	REPAIR (QUAD) (N) (BAY)	REPAIR (QUAD) (W) (BAY)	REPAIR REACT (MISC) (HARDWARE)	REPAIR REACT (CYLINDERS)	REPAIR (QUAD - ELITE) NARROW (BAY)	REPAIR (QUAD - ELITE) WIDE (BAY)
UNIT	EA Each	EA Each	EA Each	EA Each	EA Each	EA Each	EA Each	EA Each	EA Each	EA Each
<b>PROJECT TOTALS</b>	<b>1</b>	<b>1</b>	<b>1</b>	<b>1</b>	<b>1</b>	<b>1</b>	<b>1</b>	<b>1</b>	<b>4</b>	<b>1</b>

CATEGORY OF WORK	Roadway	Roadway	Roadway	Roadway	Roadway	Roadway	Roadway	Roadway	Roadway	Roadway
BID CODE	774-6041	774-6042	774-6043	774-6073	774-6074	774-6076	774-6083	774-6084	774-6085	774-6086
DESCRIPTION	REMOVE / REPLACE (QUAD - ELITE) NARROW	REMOVE / REPLACE (QUAD - ELITE) WIDE	REPAIR (QUADGUARD - ELITE) (CYLINDER)	REPAIR (QUAD) (N) (NOSE)	REPAIR (QUAD) (W) (NOSE)	REPAIR QUAD (W) (MISC HARDWARE)	QUAD(N)(BAY)CARTRIDGE(REMOVE & REPLACE)	QUAD(N)(BAY)NOSE ASSMBLY(REMOVE&REPLACE)	QUAD(N)(BAY)DIAPHRAGM(REMOVE & REPLACE)	QUAD(W)(BAY)CARTRIDGE(REMOVE & REPLACE)
UNIT	EA Each	EA Each	EA Each	EA Each	EA Each	EA Each	EA Each	EA Each	EA Each	EA Each
<b>PROJECT TOTALS</b>	<b>1</b>	<b>1</b>	<b>4</b>	<b>1</b>	<b>1</b>	<b>1</b>	<b>1</b>	<b>1</b>	<b>1</b>	<b>1</b>

CATEGORY OF WORK	Roadway	Roadway	Roadway	Roadway	Roadway	Roadway	Roadway	Roadway	Roadway	Roadway
BID CODE	774-6087	774-6088	774-6101	774-6103	774-6117	774-6118	774-6119	774-6120	774-6122	774-6123
DESCRIPTION	QUAD(W)(BAY)NOSE ASSMBLY(REMOVE&REPLACE)	QUAD(W)(BAY)DIAPHRAGM(REMOVE & REPLACE)	QUAD FENDER PANEL	REACT DECAL	REMOVE AND REPLACE (QUADGUARD)(MASH)(N)	REPAIR (QUADGUARD)(MASH)(N)	REPAIR (QUADGUARD)(MASH)(N) (BAY)	REPAIR (QUADGUARD)(MASH)(N)	REPAIR (TAU)(MASH)(N)	REPAIR (TAU)(MASH)(N)(BAY)
UNIT	EA Each	EA Each	EA Each	EA Each	EA Each	EA Each	EA Each	LF Linear Feet	EA Each	EA Each
<b>PROJECT TOTALS</b>	<b>1</b>	<b>1</b>	<b>1</b>	<b>1</b>	<b>1</b>	<b>1</b>	<b>5</b>	<b>30</b>	<b>1</b>	<b>4</b>

CATEGORY OF WORK	Roadway	Roadway	Roadway	Roadway	Roadway
BID CODE	774-6124	774-6125	774-6126	6001-6001	6185-6002
DESCRIPTION	REPAIR (TAU)(MASH)(N)	REMOVE AND REPLACE (QUADGUARD)(M10)(W)	REMOVE AND REPLACE (REACT)(M)(NARROW)	PORTABLE CHANGEABLE MESSAGE SIGN	TMA (STATIONARY)
UNIT	LF Linear Feet	EA Each	EA Each	DAY Day	DAY Day
<b>PROJECT TOTALS</b>	<b>30</b>	<b>1</b>	<b>1</b>	<b>4</b>	<b>113</b>

**SUMMARY SHEET**

SHEET 2 OF 2



FED. RD. DIV. NO.	MAINTENANCE PROJECT NO.	SHEET NO.	
		15	
STATE	DIST.	COUNTY	
TEXAS	BMT	JEFFERSON, etc	
CONT.	SECT.	JOB	HIGHWAY NO.
6435	38	001	IH10, etc

DISCLAIMER: The use of this standard is governed by the "Texas Engineering Practice Act". No warranty of any kind is made by TxDOT for any purpose whatsoever. TxDOT assumes no responsibility for the conversion of this standard to other formats or for incorrect results or damages resulting from its use.

DATE:  
 FILE:

**BARRICADE AND CONSTRUCTION (BC) STANDARD SHEETS GENERAL NOTES:**

1. The Barricade and Construction Standard Sheets (BC sheets) are intended to show typical examples for placement of temporary traffic control devices, construction pavement markings, and typical work zone signs. The information contained in these sheets meet or exceed the requirements shown in the "Texas Manual on Uniform Traffic Control Devices" (TMUTCD).
2. The development and design of the Traffic Control Plan (TCP) is the responsibility of the Engineer.
3. The Contractor may propose changes to the TCP that are signed and sealed by a licensed professional engineer for approval. The Engineer may develop, sign and seal Contractor proposed changes.
4. The Contractor is responsible for installing and maintaining the traffic control devices as shown in the plans. The Contractor may not move or change the approximate location of any device without the approval of the Engineer.
5. Geometric design of lane shifts and detours should, when possible, meet the applicable design criteria contained in manuals such as the American Association of State Highway and Transportation Officials (AASHTO), "A Policy on Geometric Design of Highways and Streets," the TxDOT "Roadway Design Manual" or engineering judgment.
6. When projects abut, the Engineer(s) may omit the END ROAD WORK, TRAFFIC FINES DOUBLE, and other advance warning signs if the signing would be redundant and the work areas appear continuous to the motorists. If the adjacent project is completed first, the Contractor shall erect the necessary warning signs as shown on these sheets, the TCP sheets or as directed by the Engineer. The BEGIN ROAD WORK NEXT X MILES sign shall be revised to show appropriate work zone distance.
7. The Engineer may require duplicate warning signs on the median side of divided highways where median width will permit and traffic volumes justify the signing.
8. All signs shall be constructed in accordance with the details found in the "Standard Highway Sign Designs for Texas," latest edition. Sign details not shown in this manual shall be shown in the plans or the Engineer shall provide a detail to the Contractor before the sign is manufactured.
9. The temporary traffic control devices shown in the illustrations of the BC sheets are examples. As necessary, the Engineer will determine the most appropriate traffic control devices to be used.
10. Where highway construction or maintenance work is being undertaken, other than mobile operations as defined by the Texas Manual on Uniform Traffic Control Devices, CSJ limit signs are required. CSJ limit signs are shown on BC(2). The OBEY WARNING SIGNS STATE LAW sign, STAY ALERT TALK OR TEXT LATER and the WORK ZONE TRAFFIC FINES DOUBLE sign with plaque shall be erected in advance of the CSJ limits. The BEGIN ROAD WORK NEXT X MILES, CONTRACTOR and END ROAD WORK signs shall be erected at or near the CSJ limits. For mobile operations, CSJ limit signs are not required.
11. Traffic control devices should be in place only while work is actually in progress or a definite need exists.
12. The Engineer has the final decision on the location of all traffic control devices.
13. Inactive equipment and work vehicles, including workers' private vehicles must be parked away from travel lanes. They should be as close to the right-of-way line as possible, or located behind a barrier or guardrail, or as approved by the Engineer.

**WORKER SAFETY NOTES:**

1. Workers on foot who are exposed to traffic or to construction equipment within the right-of-way shall wear high-visibility safety apparel meeting the requirements of ISEA "American National Standard for High-Visibility Apparel," or equivalent revisions, and labeled as ANSI 107-2004 standard performance for Class 2 or 3 risk exposure. Class 3 garments should be considered for high traffic volume work areas or night time work.
2. Except in emergency situations, flagger stations shall be illuminated when flagging is used at night.

**COMPLIANT WORKZONE TRAFFIC CONTROL DEVICES**

1. Only pre-qualified products shall be used. The "Compliant Work Zone Traffic Control Devices List" (CWZTCD) describes pre-qualified products and their sources.
2. Work zone traffic control devices shall be compliant with the Manual for Assessing safety Hardware (MASH).

<p><b>THE DOCUMENTS BELOW CAN BE FOUND ON-LINE AT</b>  <a href="http://www.txdot.gov">http://www.txdot.gov</a></p>
COMPLIANT WORK ZONE TRAFFIC CONTROL DEVICES LIST (CWZTCD)
DEPARTMENTAL MATERIAL SPECIFICATIONS (DMS)
MATERIAL PRODUCER LIST (MPL)
ROADWAY DESIGN MANUAL - SEE "MANUALS (ONLINE MANUALS)"
STANDARD HIGHWAY SIGN DESIGNS FOR TEXAS (SHSD)
TEXAS MANUAL ON UNIFORM TRAFFIC CONTROL DEVICES (TMUTCD)
TRAFFIC ENGINEERING STANDARD SHEETS

SHEET 1 OF 12



**BARRICADE AND CONSTRUCTION  
 GENERAL NOTES  
 AND REQUIREMENTS**

**BC (1) - 21**

FILE:	bc-21.dgn	DN:	TxDOT	CK:	TxDOT	DW:	TxDOT	CR:	TxDOT
© TxDOT	November 2002	CONT	SECT	JOB	HIGHWAY				
REVISIONS		6435	38	001	IH10, etc				
4-03	7-13	DIST	COUNTY		SHEET NO.				
9-07	8-14	BMT	JEFFERSON, etc		16				
5-10	5-21								



**TYPICAL LOCATION OF CROSSROAD SIGNS**

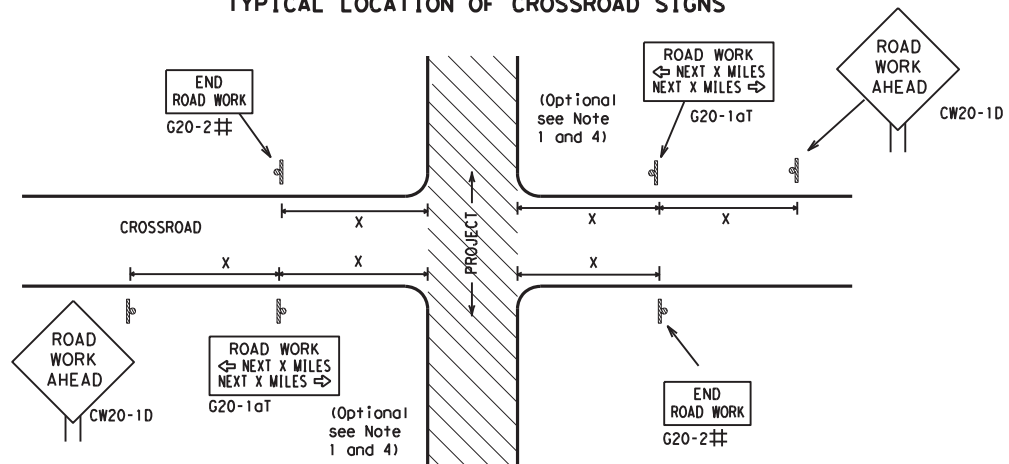

## May be mounted on back of "ROAD WORK AHEAD" (CW20-1D) sign with approval of Engineer. (See note 2 below)

1. The typical minimum signing on a crossroad approach should be a "ROAD WORK AHEAD" (CW20-1D) sign and a (G20-2) "END ROAD WORK" sign, unless noted otherwise in plans.
2. The Engineer may use the reduced size 36" x 36" ROAD WORK AHEAD (CW20-1D) sign mounted back to back with the reduced size 36" x 18" "END ROAD WORK" (G20-2) sign on low volume crossroads (see Note 4 under "Typical Construction Warning Sign Size and Spacing"). See the "Standard Highway Sign Designs for Texas" manual for sign details. The Engineer may omit the advance warning signs on low volume crossroads. The Engineer will determine whether a road is low volume as per TMUTCD Part 5. This information shall be shown in the plans.
3. Based on existing field conditions, the Engineer/Inspector may require additional signs such as FLAGGER AHEAD, LOOSE GRAVEL, or other appropriate signs. When additional signs are required, these signs will be considered part of the minimum requirements. The Engineer/Inspector will determine the proper location and spacing of any sign not shown on the BC sheets, Traffic Control Plan sheets or the Work Zone Standard Sheets.
4. The "ROAD WORK NEXT X MILES" (G20-1aT) sign shall be required at high volume crossroads to advise motorists of the length of construction in either direction from the intersection. The Engineer will determine whether a roadway is considered high volume.
5. Additional traffic control devices may be shown elsewhere in the plans for higher volume crossroads.
6. When work occurs in the intersection area, appropriate traffic control devices, as shown elsewhere in the plans or as determined by the Engineer/Inspector, shall be in place.

**T-INTERSECTION**

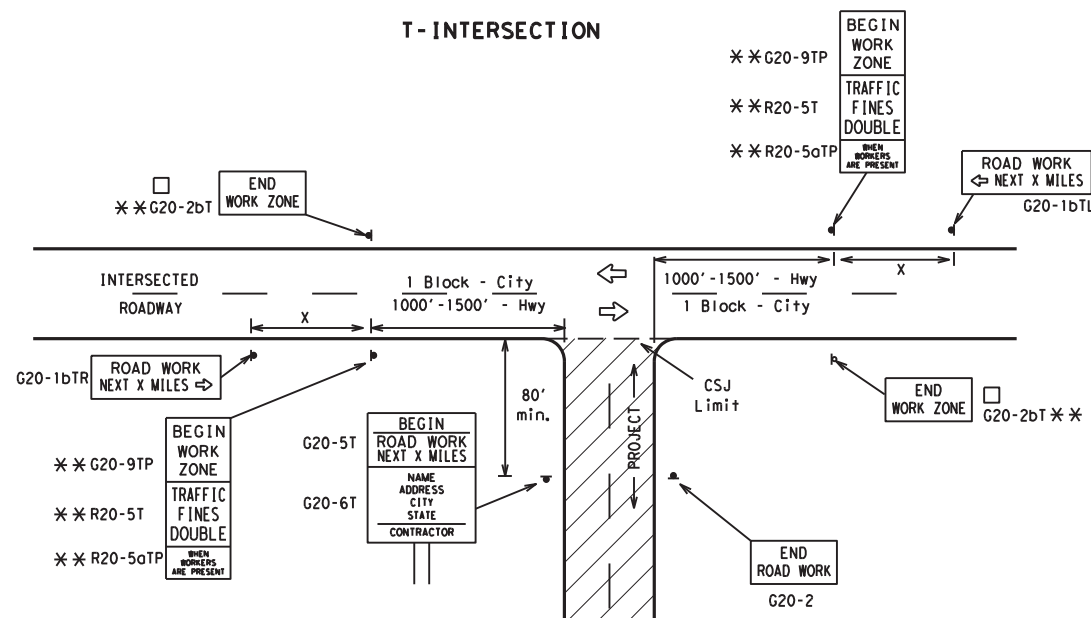

**CSJ LIMITS AT T-INTERSECTION**

1. The Engineer will determine the types and location of any additional traffic control devices, such as a flagger and accompanying signs, or other signs, that should be used when work is being performed at or near an intersection.
2. If construction closes the road at a T-intersection, the Contractor shall place the "CONTRACTOR NAME" (G20-6T) sign behind the Type 3 Barricades for the road closure (see BC(10) also). The "ROAD WORK NEXT X MILES" left arrow (G20-1bTL) and "ROAD WORK NEXT X MILES" right arrow (G20-1bTR) signs shall be replaced by the detour signing called for in the plans.

**TYPICAL CONSTRUCTION WARNING SIGN SIZE AND SPACING<sup>1,5,6</sup>**

Sign Number or Series	SIZE		SPACING	
	Conventional Road	Expressway/Freeway	Posted Speed MPH	Sign Δ Spacing "x" Feet (Apprx.)
CW20 <sup>4</sup>	48" x 48"	48" x 48"	30	120
CW21			35	160
CW22			40	240
CW23			45	320
CW1, CW2, CW7, CW8, CW9, CW11, CW14	36" x 36"	48" x 48"	50	400
CW3, CW4, CW5, CW6, CW8-3, CW10, CW12	48" x 48"	48" x 48"	60	600 <sup>2</sup>
			65	700 <sup>2</sup>
			70	800 <sup>2</sup>
			75	900 <sup>2</sup>
			80	1000 <sup>2</sup>
			*	* <sup>3</sup>

\* For typical sign spacings on divided highways, expressways and freeways, see Part 6 of the "Texas Manual on Uniform Traffic Control Devices" (TMUTCD) typical application diagrams or TCP Standard Sheets.

Δ Minimum distance from work area to first Advance Warning sign nearest the work area and/or distance between each additional sign.

**GENERAL NOTES**

1. Special or larger size signs may be used as necessary.
2. Distance between signs should be increased as required to have 1500 feet advance warning.
3. Distance between signs should be increased as required to have 1/2 mile or more advance warning.
4. 36" x 36" "ROAD WORK AHEAD" (CW20-1D) signs may be used on low volume crossroads at the discretion of the Engineer as per TMUTCD Part 5. See Note 2 under "Typical Location of Crossroad Signs".
5. Only diamond shaped warning sign sizes are indicated.
6. See sign size listing in "TMUTCD", Sign Appendix or the "Standard Highway Sign Designs for Texas" manual for complete list of available sign design sizes.

**WORK AREAS IN MULTIPLE LOCATIONS WITHIN CSJ LIMITS**

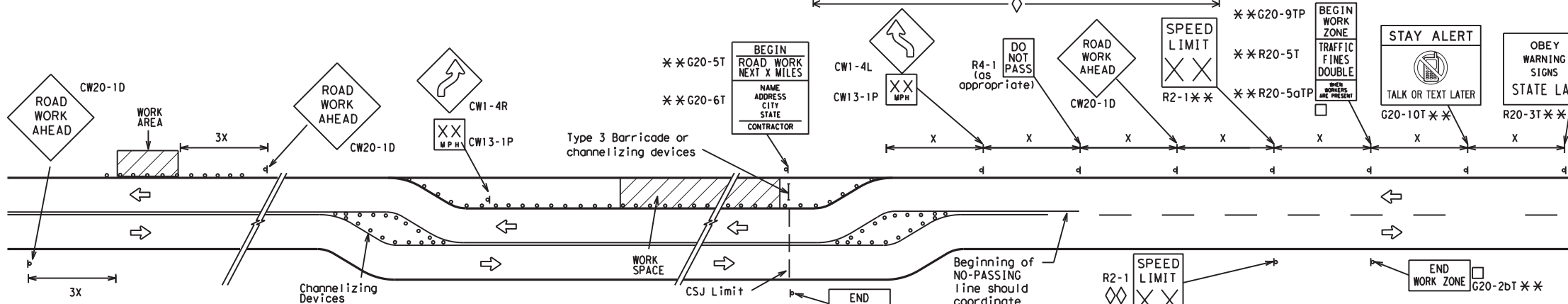

When extended distances occur between minimal work spaces, the Engineer/Inspector should ensure additional "ROAD WORK AHEAD" (CW20-1D) signs are placed in advance of these work areas to remind drivers they are still within the project limits. See the applicable TCP sheets for exact location and spacing of signs and channelizing devices.

**SAMPLE LAYOUT OF SIGNING FOR WORK BEGINNING DOWNSTREAM OF THE CSJ LIMITS**

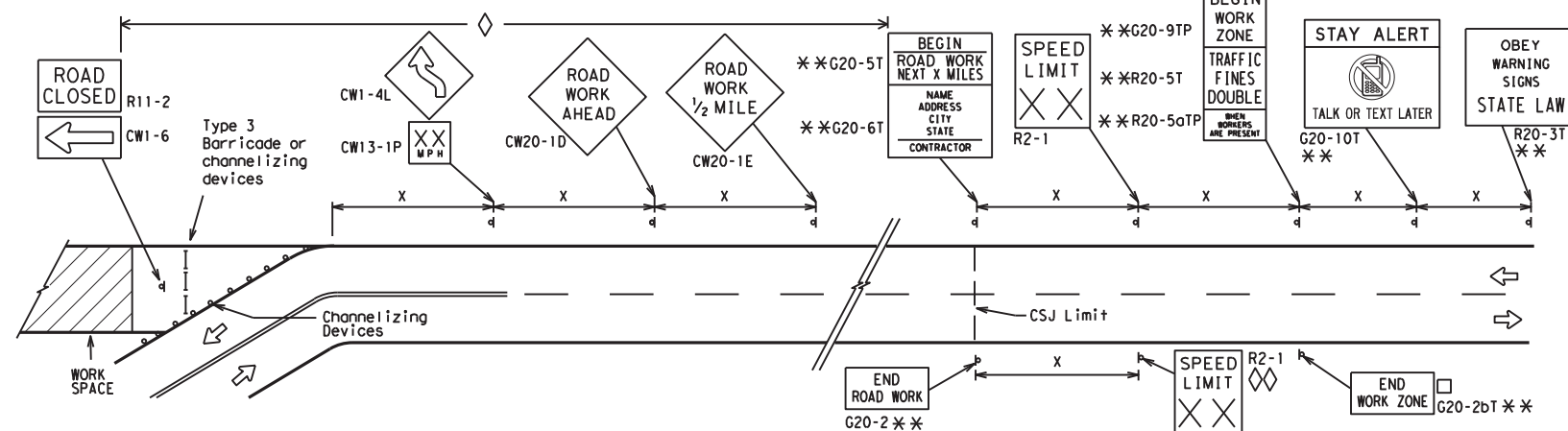

**SAMPLE LAYOUT OF SIGNING FOR WORK BEGINNING AT THE CSJ LIMITS**

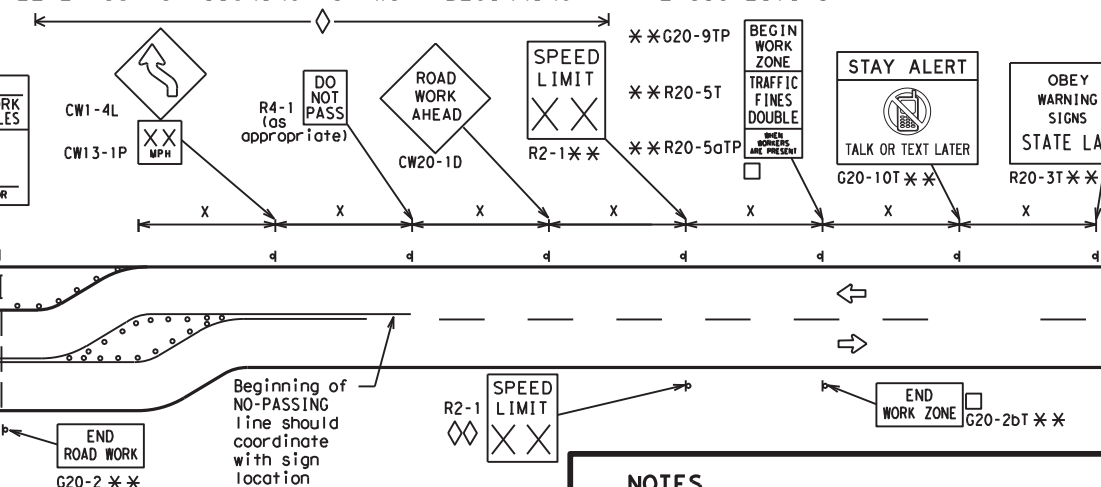

**NOTES**

- The Contractor shall determine the appropriate distance to be placed on the G20-1 series signs and "BEGIN ROAD WORK NEXT X MILES" (G20-1aT) sign for each specific project. This distance shall replace the "x" and shall be rounded to the nearest whole mile with the approval of the Engineer. No decimals shall be used.
- The "BEGIN WORK ZONE" (G20-9TP) and "END WORK ZONE" (G20-2bT) shall be used as shown on the sample layout when advance signs are required outside the CSJ Limits. They inform the motorist of entering or leaving a part of the work zone lying outside the CSJ Limits where traffic fines may double if workers are present.
- CSJ limit signing is required for highway construction and maintenance work, with the exception of mobile operations.
- Area for placement of "ROAD WORK AHEAD" (CW20-1D) sign and other signs or devices as called for on the Traffic Control Plan.
- Contractor will install a regulatory speed limit sign at the end of the work zone.

**LEGEND**

—	Type 3 Barricade
○ ○ ○	Channelizing Devices
■	Sign
X	See Typical Construction Warning Sign Size and Spacing chart or the TMUTCD for sign spacing requirements.

SHEET 2 OF 12



**BARRICADE AND CONSTRUCTION PROJECT LIMIT**

**BC(2)-21**

FILE: bc-21.dgn	DN: TxDOT	CK: TxDOT	DW: TxDOT	CR: TxDOT
© TxDOT November 2002	CONT	SECT	JOB	HIGHWAY
REVISIONS	6435	38	001	IH10, etc
9-07 8-14	DIST	COUNTY	SHEET NO.	
7-13 5-21	BMT	JEFFERSON, etc	17	

DISCLAIMER: The use of this standard is governed by the "Texas Engineering Practice Act". No warranty of any kind is made by TxDOT for any purpose whatsoever. TxDOT assumes no responsibility for the conversion of this standard to other formats or for incorrect results or damages resulting from its use.

DATE: FILE:

# TYPICAL APPLICATION OF WORK ZONE SPEED LIMIT SIGNS

Work zone speed limits shall be regulatory, established in accordance with the "Procedures for Establishing Speed Zones," and approved by the Texas Transportation Commission, or by City Ordinance when within Incorporated City Limits.

Reduced speeds should only be posted in the vicinity of work activity and not throughout the entire project. Regulatory work zone speed signs (R2-1) shall be removed or covered during periods when they are not needed.

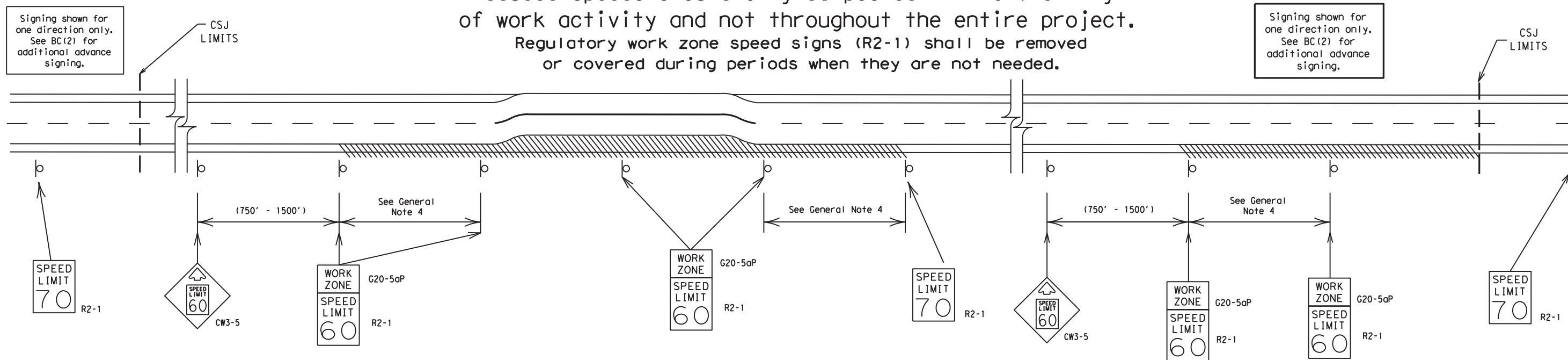

## GUIDANCE FOR USE:

### LONG/INTERMEDIATE TERM WORK ZONE SPEED LIMITS

This type of work zone speed limit should be included on the design of the traffic control plans when restricted geometrics with a lower design speed are present in the work zone and modification of the geometrics to a higher design speed is not feasible.

Long/Intermediate Term Work Zone Speed Limit signs, when approved as described above, should be posted and visible to the motorist when work activity is present. Work activity may also be defined as a change in the roadway that requires a reduced speed for motorists to safely negotiate the work area, including:

- rough road or damaged pavement surface
- substantial alteration of roadway geometrics (diversions)
- construction detours
- grade
- width
- other conditions readily apparent to the driver

As long as any of these conditions exist, the work zone speed limit signs should remain in place.

### SHORT TERM WORK ZONE SPEED LIMITS

This type of work zone speed limit may be included on the design of the traffic control plans when workers or equipment are not behind concrete barrier, when work activity is within 10 feet of the traveled way or actually in the traveled way.

Short Term Work Zone Speed Limit signs should be posted and visible to the motorists only when work activity is present. When work activity is not present, signs shall be removed or covered. (See Removing or Covering on BC(4)).

### GENERAL NOTES

- Regulatory work zone speed limits should be used only for sections of construction projects where speed control is of major importance.
- Regulatory work zone speed limit signs shall be placed on supports at a 7 foot minimum mounting height.
- Speed zone signs are illustrated for one direction of travel and are normally posted for each direction of travel.
- Frequency of work zone speed limit signs should be:
 

40 mph and greater	0.2 to 2 miles
35 mph and less	0.2 to 1 mile
- Regulatory speed limit signs shall have black legend and border on a white reflective background (See "Reflective Sheeting" on BC(4)).
- Fabrication, erection and maintenance of the "ADVANCE SPEED LIMIT" (CW3-5) sign, "WORK ZONE" (G20-5aP) plaque and the "SPEED LIMIT" (R2-1) signs shall not be paid for directly, but shall be considered subsidiary to Item 502.
- Turning signs from view, laying signs over or down will not be allowed, unless as otherwise noted under "REMOVING OR COVERING" on BC(4).
- Techniques that may help reduce traffic speeds include but are not limited to:
  - Law enforcement.
  - Flagger stationed next to sign.
  - Portable changeable message sign (PCMS).
  - Low-power (drone) radar transmitter.
  - Speed monitor trailers or signs.
- Speeds shown on details above are for illustration only. Work Zone Speed Limits should only be posted as approved for each project.
- For more specific guidance concerning the type of work, work zone conditions and factors impacting allowable regulatory construction speed zone reduction see TxDOT form #1204 in the TxDOT e-form system.

DISCLAIMER: The use of this standard is governed by the "Texas Engineering Practice Act". No warranty of any kind is made by TxDOT for any purpose whatsoever. TxDOT assumes no responsibility for the conversion of this standard to other formats or for incorrect results or damages resulting from its use.

DATE:  
FILE:

SHEET 3 OF 12



## BARRICADE AND CONSTRUCTION WORK ZONE SPEED LIMIT

BC (3) - 21

FILE:	bc-21.dgn	DW:	TxDOT	CK:	TxDOT	DW:	TxDOT	CK:	TxDOT
© TxDOT	November 2002	CONT	SECT	JOB	HIGHWAY				
REVISIONS		6435	38	001	I110, etc				
9-07	8-14								
7-13	5-21	DIST	COUNTY		SHEET NO.				
		BMT	JEFFERSON, etc		18				

**TYPICAL MINIMUM CLEARANCES FOR LONG TERM AND INTERMEDIATE TERM SIGNS**

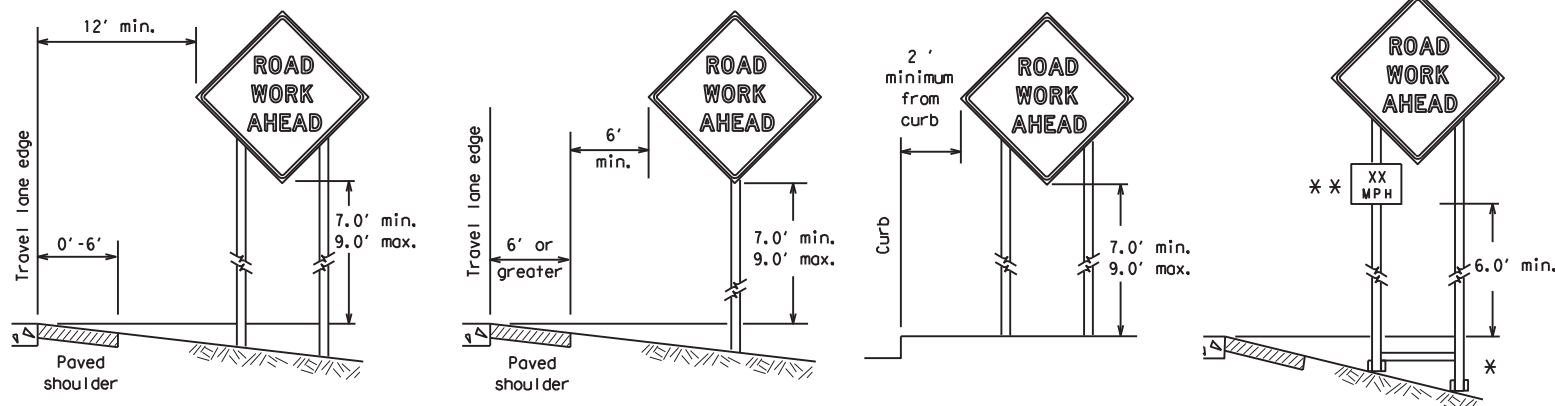

\* When placing skid supports on unlevel ground, the leg post lengths must be adjusted so the sign appears straight and plumb. Objects shall NOT be placed under skids as a means of leveling.

\*\* When plaques are placed on dual-leg supports, they should be attached to the upright nearest the travel lane. Supplemental plaques (advisory or distance) should not cover the surface of the parent sign.

**ATTACHMENT FOR SIGN SUPPORTS**

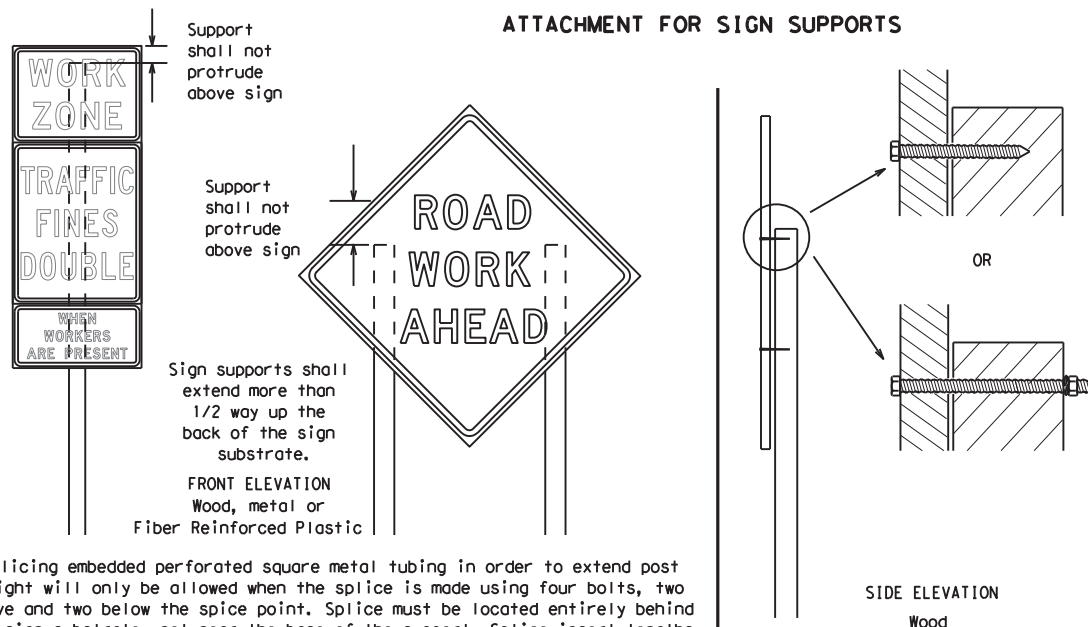

Attachment to wooden supports will be by bolts and nuts or screws. Use TxDOT's or manufacturer's recommended procedures for attaching sign substrates to other types of sign supports

**Nails shall NOT be allowed.**  
Each sign shall be attached directly to the sign support. Multiple signs shall not be joined or spliced by any means. Wood supports shall not be extended or repaired by splicing or other means.

Splicing embedded perforated square metal tubing in order to extend post height will only be allowed when the splice is made using four bolts, two above and two below the splice point. Splice must be located entirely behind the sign substrate, not near the base of the support. Splice insert lengths should be at least 5 times nominal post size, centered on the splice and of at least the same gauge material.

**STOP/SLOW PADDLES**

1. STOP/SLOW paddles are the primary method to control traffic by flaggers. The STOP/SLOW paddle size should be 24" x 24".
2. STOP/SLOW paddles shall be retroreflectORIZED when used at night.
3. STOP/SLOW paddles may be attached to a staff with a minimum length of 6' to the bottom of the sign.
4. Any lights incorporated into the STOP or SLOW paddle faces shall only be as specifically described in Section 6E.03 Hand Signaling Devices in the TMUTCD.

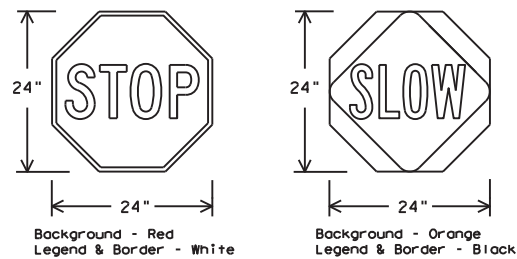

SHEETING REQUIREMENTS (WHEN USED AT NIGHT)		
USAGE	COLOR	SIGN FACE MATERIAL
BACKGROUND	RED	TYPE B OR C SHEETING
BACKGROUND	ORANGE	TYPE B <sub>FL</sub> OR C <sub>FL</sub> SHEETING
LEGEND & BORDER	WHITE	TYPE B OR C SHEETING
LEGEND & BORDER	BLACK	ACRYLIC NON-REFLECTIVE FILM

**CONTRACTOR REQUIREMENTS FOR MAINTAINING PERMANENT SIGNS WITHIN THE PROJECT LIMITS**

1. Permanent signs are used to give notice of traffic laws or regulations, call attention to conditions that are potentially hazardous to traffic operations, show route designations, destinations, directions, distances, services, points of interest, and other geographical, recreational, specific service (LOGO), or cultural information. Drivers proceeding through a work zone need the same, if not better route guidance as normally installed on a roadway without construction.
2. When permanent regulatory or warning signs conflict with work zone conditions, remove or cover the permanent signs until the permanent sign message matches the roadway condition. For details for covering large guide signs see the TS-CD standard.
3. When existing permanent signs are moved and relocated due to construction purposes, they shall be visible to motorists at all times.
4. If existing signs are to be relocated on their original supports, they shall be installed on crashworthy bases as shown on the SMD Standard sheets. The signs shall meet the required mounting heights shown on the BC Sheets or the SMD Standards. This work should be paid for under the appropriate pay item for relocating existing signs.
5. If permanent signs are to be removed and relocated using temporary supports, the Contractor shall use crashworthy supports as shown on the BC standard sheets, TLRs standard sheets or the CWZTCD list. The signs shall meet the required mounting heights shown on the BC, or the SMD standard sheets during construction. This work should be paid for under the appropriate pay item for relocating existing signs.
6. Any sign or traffic control device that is struck or damaged by the Contractor or his/her construction equipment shall be replaced as soon as possible by the Contractor to ensure proper guidance for the motorists. This will be subsidiary to Item 502.

**GENERAL NOTES FOR WORK ZONE SIGNS**

1. Contractor shall install and maintain signs in a straight and plumb condition and/or as directed by the Engineer.
2. Wooden sign posts shall be painted white.
3. Barricades shall NOT be used as sign supports.
4. All signs shall be installed in accordance with the plans or as directed by the Engineer. Signs shall be used to regulate, warn, and guide the traveling public safely through the work zone.
5. The Contractor may furnish either the sign design shown in the plans or in the "Standard Highway Sign Designs for Texas" (SHSD). The Engineer/Inspector may require the Contractor to furnish other work zone signs that are shown in the TMUTCD but may have been omitted from the plans. Any variation in the plans shall be documented by written agreement between the Engineer and the Contractor's Responsible Person. All changes must be documented in writing before being implemented. This can include documenting the changes in the Inspector's TxDOT diary and having both the Inspector and Contractor initial and date the agreed upon changes.
6. The Contractor shall furnish sign supports listed in the "Compliant Work Zone Traffic Control Device List" (CWZTCD) for small roadside signs. Supports for temporary large roadside signs shall meet the requirements detailed on the Temporary Large Roadside Signs (TLRS) standard sheets. The Contractor shall install the sign support in accordance with the manufacturer's recommendations. If there is a question regarding installation procedures, the Contractor shall furnish the Engineer a copy of the manufacturer's installation recommendations so the Engineer can verify the correct procedures are being followed.
7. The Contractor is responsible for installing signs on approved supports and replacing signs with damaged or cracked substrates and/or damaged or marred reflective sheeting as directed by the Engineer/Inspector.
8. Identification markings may be shown only on the back of the sign substrate. The maximum height of letters and/or company logos used for identification shall be 1 inch.
9. The Contractor shall replace damaged wood posts. New or damaged wood sign posts shall not be spliced.

**DURATION OF WORK (as defined by the "Texas Manual on Uniform Traffic Control Devices" Part 6)**

1. The types of sign supports, sign mounting height, the size of signs, and the type of sign substrates can vary based on the type of work being performed. The Engineer is responsible for selecting the appropriate size sign for the type of work being performed. The Contractor is responsible for ensuring the sign support, sign mounting height and substrate meets manufacturer's recommendations in regard to crashworthiness and duration of work requirements.
  - a. Long-term stationary - work that occupies a location more than 3 days.
  - b. Intermediate-term stationary - work that occupies a location more than one daylight period up to 3 days, or nighttime work lasting more than one hour.
  - c. Short-term stationary - daytime work that occupies a location for more than 1 hour in a single daylight period.
  - d. Short, duration - work that occupies a location up to 1 hour.
  - e. Mobile - work that moves continuously or intermittently (stopping for up to approximately 15 minutes.)

**SIGN MOUNTING HEIGHT**

1. The bottom of Long-term/Intermediate-term signs shall be at least 7 feet, but not more than 9 feet, above the paved surface, except as shown for supplemental plaques mounted below other signs.
2. The bottom of Short-term/Short Duration signs shall be a minimum of 1 foot above the pavement surface but no more than 2 feet above the ground.
3. Long-term/Intermediate-term Signs may be used in lieu of Short-term/Short Duration signing.
4. Short-term/Short Duration signs shall be used only during daylight and shall be removed at the end of the workday or raised to appropriate Long-term/Intermediate sign height.
5. Regulatory signs shall be mounted at least 7 feet, but not more than 9 feet, above the paved surface regardless of work duration.

**SIZE OF SIGNS**

1. The Contractor shall furnish the sign sizes shown on BC (2) unless otherwise shown in the plans or as directed by the Engineer.

**SIGN SUBSTRATES**

1. The Contractor shall ensure the sign substrate is installed in accordance with the manufacturer's recommendations for the type of sign support that is being used. The CWZTCD lists each substrate that can be used on the different types and models of sign supports.
2. "Mesh" type materials are NOT an approved sign substrate, regardless of the tightness of the weave.
3. All wooden individual sign panels fabricated from 2 or more pieces shall have one or more plywood cleat, 1/2" thick by 6" wide, fastened to the back of the sign and extending fully across the sign. The cleat shall be attached to the back of the sign using wood screws that do not penetrate the face of the sign panel. The screws shall be placed on both sides of the splice and spaced at 6" centers. The Engineer may approve other methods of splicing the sign face.

**REFLECTIVE SHEETING**

1. All signs shall be retroreflective and constructed of sheeting meeting the color and retro-reflectivity requirements of DMS-8300 for rigid signs or DMS-8310 for roll-up signs. The web address for DMS specifications is shown on BC(1).
2. White sheeting, meeting the requirements of DMS-8300 Type A, shall be used for signs with a white background.
3. Orange sheeting, meeting the requirements of DMS-8300 Type B<sub>FL</sub> or Type C<sub>FL</sub>, shall be used for rigid signs with orange backgrounds.

**SIGN LETTERS**

1. All sign letters and numbers shall be clear, and open rounded type uppercase alphabet letters as approved by the Federal Highway Administration (FHWA) and as published in the "Standard Highway Sign Design for Texas" manual. Signs, letters and numbers shall be of first class workmanship in accordance with Department Standards and Specifications.

**REMOVING OR COVERING**

1. When sign messages may be confusing or do not apply, the signs shall be removed or completely covered.
2. Long-term stationary or intermediate stationary signs installed on square metal tubing may be turned away from traffic 90 degrees when the sign message is not applicable. This technique may not be used for signs installed in the median of divided highways or near any intersections where the sign may be seen from approaching traffic.
3. Signs installed on wooden skids shall not be turned at 90 degree angles to the roadway. These signs should be removed or completely covered when not required.
4. When signs are covered, the material used shall be opaque, such as heavy mil black plastic, or other materials which will cover the entire sign face and maintain their opaque properties under automobile headlights at night, without damaging the sign sheeting.
5. Burlap shall NOT be used to cover signs.
6. Duct tape or other adhesive material shall NOT be affixed to a sign face.
7. Signs and anchor stubs shall be removed and holes backfilled upon completion of work.

**SIGN SUPPORT WEIGHTS**

1. Where sign supports require the use of weights to keep from turning over, the use of sandbags with dry, cohesionless sand should be used.
2. The sandbags will be tied shut to keep the sand from spilling and to maintain a constant weight.
3. Rock, concrete, iron, steel or other solid objects shall not be permitted for use as sign support weights.
4. Sandbags should weigh a minimum of 35 lbs and a maximum of 50 lbs.
5. Sandbags shall be made of a durable material that tears upon vehicular impact. Rubber (such as tire inner tubes) shall NOT be used.
6. Rubber ballasts designed for channelizing devices should not be used for ballast on portable sign supports. Sign supports designed and manufactured with rubber bases may be used when shown on the CWZTCD list.
7. Sandbags shall only be placed along or laid over the base supports of the traffic control device and shall not be suspended above ground level or hung with rope, wire, chains or other fasteners. Sandbags shall be placed along the length of the skids to weigh down the sign support.
8. Sandbags shall NOT be placed under the skid and shall not be used to level sign supports placed on slopes.

**FLAGS ON SIGNS**

1. Flags may be used to draw attention to warning signs. When used, the flag shall be 16 inches square or larger and shall be orange or fluorescent red-orange in color. Flags shall not be allowed to cover any portion of the sign face.

SHEET 4 OF 12



**BARRICADE AND CONSTRUCTION TEMPORARY SIGN NOTES**

**BC (4) - 21**

FILE:	bc-21.dgn	DN:	TxDOT	CR:	TxDOT	OW:	TxDOT	CK:	TxDOT
© TxDOT	November 2002	CONT	SECT	JOB	HIGHWAY				
REVISIONS		6435	38	001	I110, etc				
9-07	8-14	DIST	COUNTY		SHEET NO.				
7-13	5-21	BMT	JEFFERSON, etc		19				

DISCLAIMER: The use of this standard is governed by the "Texas Engineering Practice Act". No warranty of any kind is made by TxDOT for any purpose whatsoever. TxDOT assumes no responsibility for the conversion of this standard to other formats or for incorrect results or damages resulting from its use.

DATE:  
FILE:

DISCLAIMER: The use of this standard is governed by the "Texas Engineering Practice Act". No warranty of any kind is made by TxDOT for any purpose whatsoever. TxDOT assumes no responsibility for the conversion of this standard to other formats or for incorrect results or damages resulting from its use.

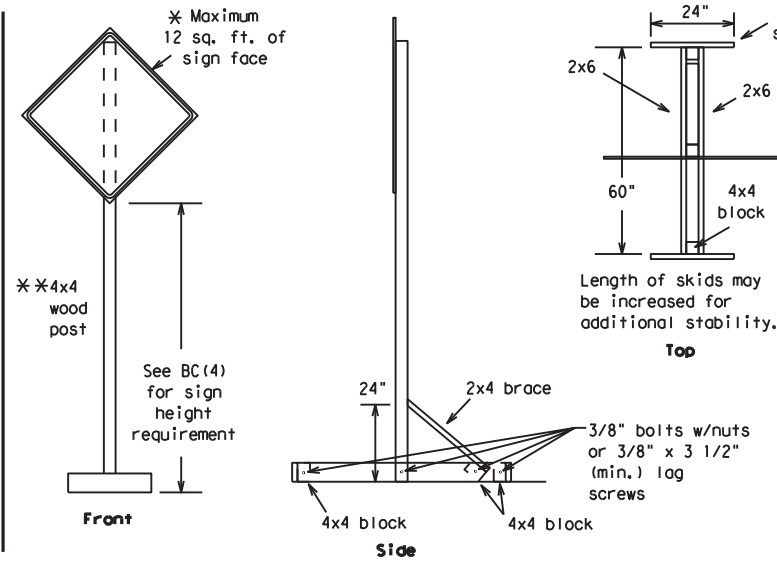
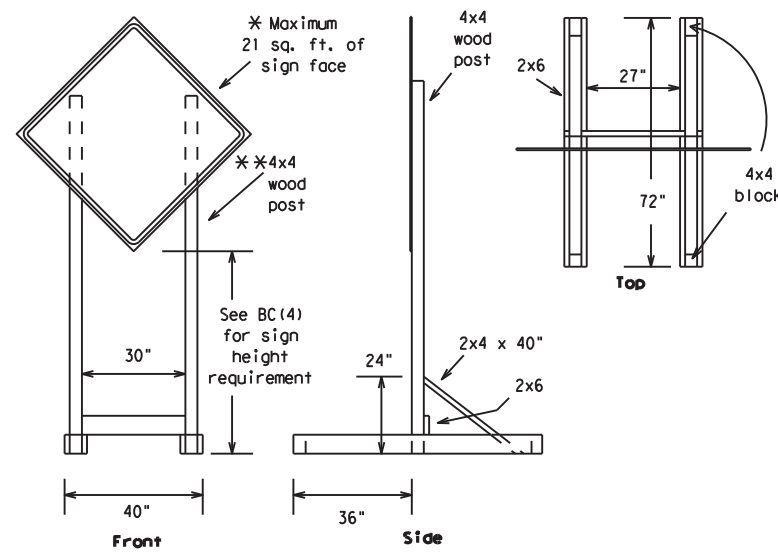

### SKID MOUNTED WOOD SIGN SUPPORTS

\* LONG/INTERMEDIATE TERM STATIONARY - PORTABLE SKID MOUNTED SIGN SUPPORTS

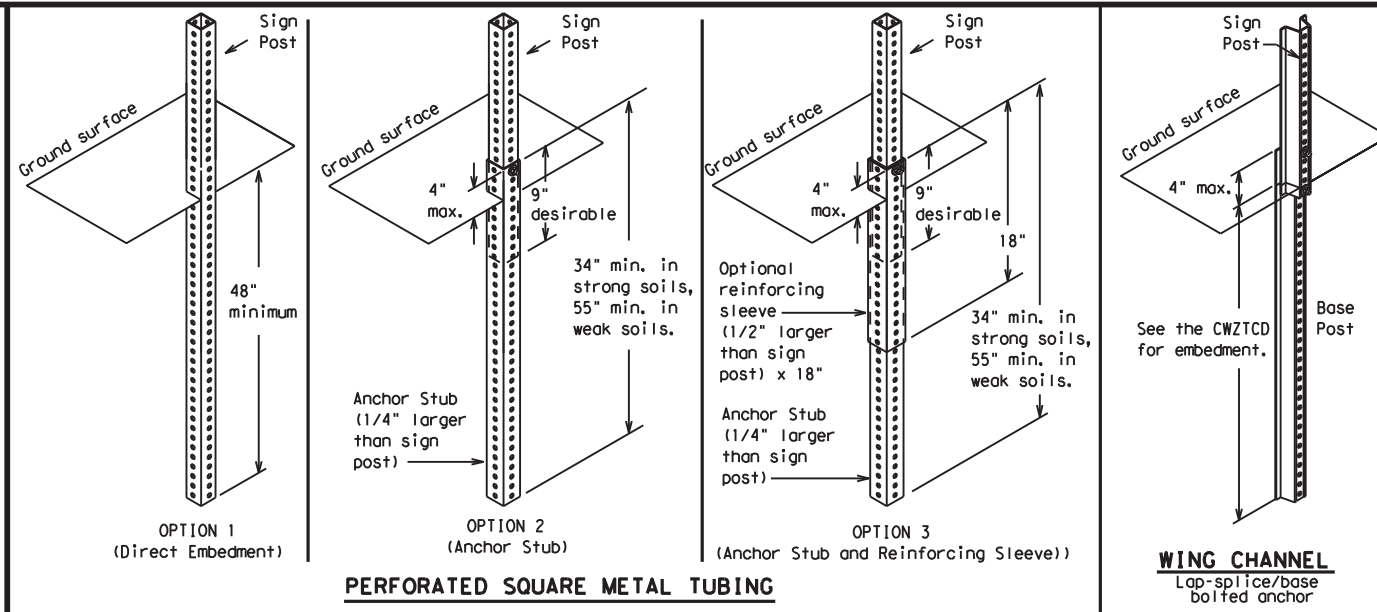

### GROUND MOUNTED SIGN SUPPORTS

Refer to the CWZTCD and the manufacturer's installation procedure for each type sign support.  
 The maximum sign square footage shall adhere to the manufacturer's recommendation.  
 Two post installations can be used for larger signs.

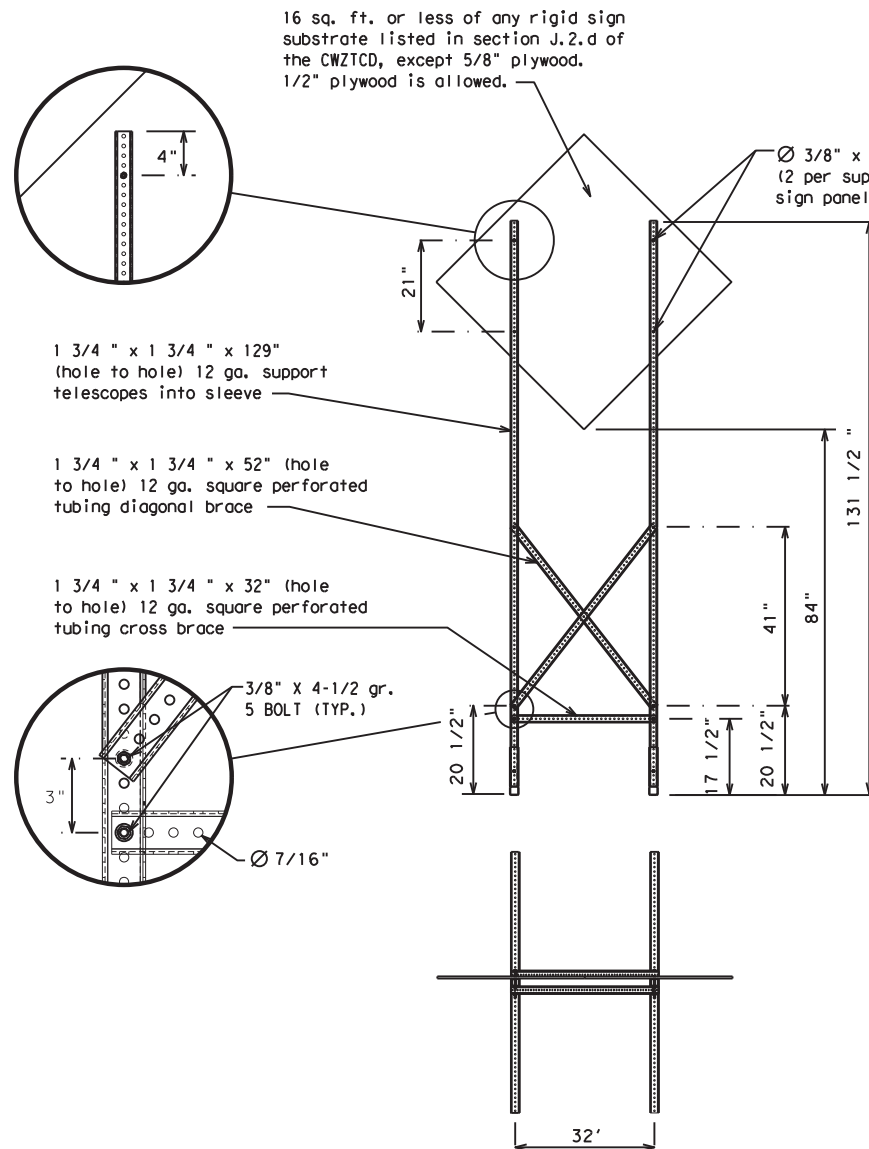
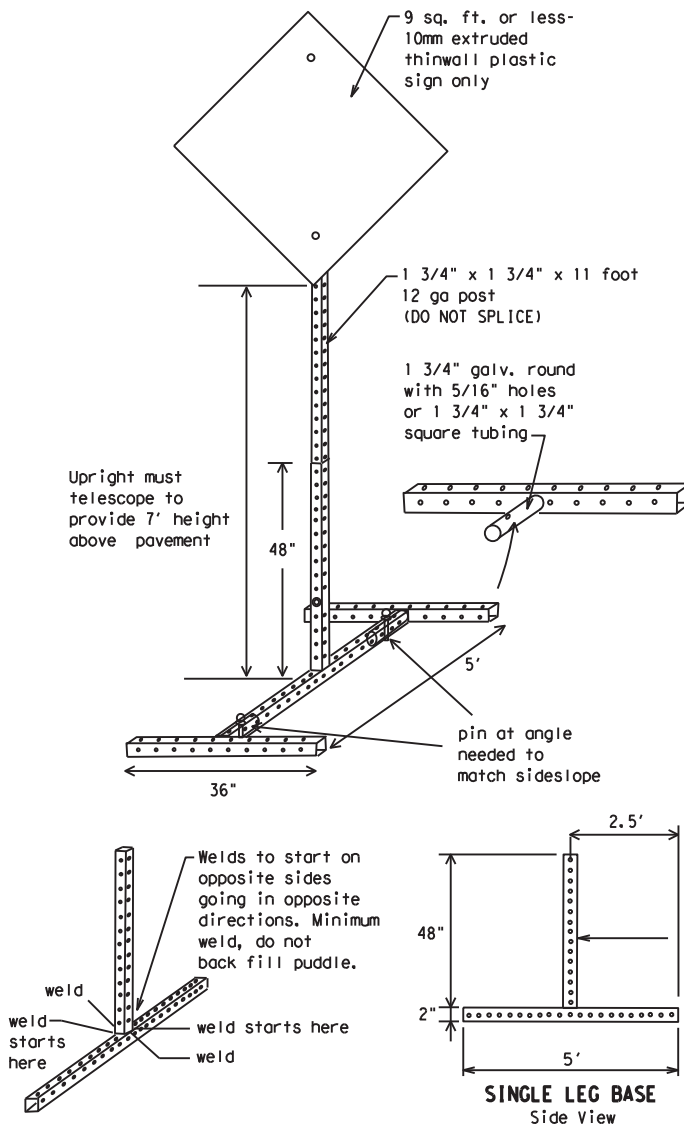

### SKID MOUNTED PERFORATED SQUARE STEEL TUBING SIGN SUPPORTS

\* LONG/INTERMEDIATE TERM STATIONARY - PORTABLE SKID MOUNTED SIGN SUPPORTS

### WEDGE ANCHORS

Both steel and plastic Wedge Anchor Systems as shown on the SMD Standard Sheets may be used as temporary sign supports for signs up to 10 square feet of sign face. They may be set in concrete or in sturdy soils if approved by the Engineer. (See web address for "Traffic Engineering Standard Sheets" on BC(1)).

### OTHER DESIGNS

MORE DETAILS OF APPROVED LONG/INTERMEDIATE AND SHORT TERM SUPPORTS CAN BE FOUND ON THE CWZTCD LIST. SEE BC(1) FOR WEBSITE LOCATION.

### GENERAL NOTES

- Nails may be used in the assembly of wooden sign supports, but 3/8" bolts with nuts or 3/8" x 3 1/2" lag screws must be used on every joint for final connection.
- No more than 2 sign posts shall be placed within a 7 ft. circle, except for specific materials noted on the CWZTCD List.
- When project is completed, all sign supports and foundations shall be removed from the project site. This will be considered subsidiary to Item 502.

- \* See BC(4) for definition of "Work Duration."
- \*\* Wood sign posts MUST be one piece. Splicing will NOT be allowed. Posts shall be painted white.
- See the CWZTCD for the type of sign substrate that can be used for each approved sign support.

SHEET 5 OF 12



## BARRICADE AND CONSTRUCTION TYPICAL SIGN SUPPORT

BC(5) - 21

FILE: bc-21.dgn	DN: TxDOT	CK: TxDOT	DW: TxDOT	CR: TxDOT
© TxDOT November 2002	CONT	SECT	JOB	HIGHWAY
REVISIONS	6435	38	001	IH10, etc
9-07 8-14	DIST	COUNTY	SHEET NO.	
7-13 5-21	BMT	JEFFERSON, etc	20	

DATE:  
FILE:

WHEN NOT IN USE, REMOVE THE PCMS FROM THE RIGHT-OF-WAY OR PLACE THE PCMS BEHIND BARRIER OR GUARDRAIL WITH SIGN PANEL TURNED PARALLEL TO TRAFFIC

# RECOMMENDED PHASES AND FORMATS FOR PCMS MESSAGES DURING ROADWORK ACTIVITIES

(The Engineer may approve other messages not specifically covered here.)

## PORTABLE CHANGEABLE MESSAGE SIGNS

- The Engineer/Inspector shall approve all messages used on portable changeable message signs (PCMS).
- Messages on PCMS should contain no more than 8 words (about four to eight characters per word), not including simple words such as "TO," "FOR," "AT," etc.
- Messages should consist of a single phase, or two phases that alternate. Three-phase messages are not allowed. Each phase of the message should convey a single thought, and must be understood by itself.
- Use the word "EXIT" to refer to an exit ramp on a freeway; i.e., "EXIT CLOSED." Do not use the term "RAMP."
- Always use the route or interstate designation (IH, US, SH, FM) along with the number when referring to a roadway.
- When in use, the bottom of a stationary PCMS message panel should be a minimum 7 feet above the roadway, where possible.
- The message term "WEEKEND" should be used only if the work is to start on Saturday morning and end by Sunday evening at midnight. Actual days and hours of work should be displayed on the PCMS if work is to begin on Friday evening and/or continue into Monday morning.
- The Engineer/Inspector may select one of two options which are available for displaying a two-phase message on a PCMS. Each phase may be displayed for either four seconds each or for three seconds each.
- Do not "flash" messages or words included in a message. The message should be steady burn or continuous while displayed.
- Do not present redundant information on a two-phase message; i.e., keeping two lines of the message the same and changing the third line.
- Do not use the word "Danger" in message.
- Do not display the message "LANES SHIFT LEFT" or "LANES SHIFT RIGHT" on a PCMS. Drivers do not understand the message.
- Do not display messages that scroll horizontally or vertically across the face of the sign.
- The following table lists abbreviated words and two-word phrases that are acceptable for use on a PCMS. Both words in a phrase must be displayed together. Words or phrases not on this list should not be abbreviated, unless shown in the TMUTCD.
- PCMS character height should be at least 18 inches for trailer mounted units. They should be visible from at least 1/2 (.5) mile and the text should be legible from at least 600 feet at night and 800 feet in daylight. Truck mounted units must have a character height of 10 inches and must be legible from at least 400 feet.
- Each line of text should be centered on the message board rather than left or right justified.
- If disabled, the PCMS should default to an illegible display that will not alarm motorists and will only be used to alert workers that the PCMS has malfunctioned. A pattern such as a series of horizontal solid bars is appropriate.

DISCLAIMER: The use of this standard is governed by the "Texas Engineering Practice Act." No warranty of any kind is made by TxDOT for any purpose whatsoever. TxDOT assumes no responsibility for the conversion of this standard to other formats or for incorrect results or damages resulting from its use.

WORD OR PHRASE	ABBREVIATION	WORD OR PHRASE	ABBREVIATION
Access Road	ACCS RD	Major	MAJ
Alternate	ALT	Miles	MI
Avenue	AVE	Miles Per Hour	MPH
Best Route	BEST RTE	Minor	MNR
Boulevard	BLVD	Monday	MON
Bridge	BRDG	Normal	NORM
Cannot	CANT	North	N
Center	CTR	Northbound	(route) N
Construction Ahead	CONST AHD	Parking	PKING
CROSSING	XING	Road	RD
Detour Route	DETOUR RTE	Right Lane	RT LN
Do Not	DONT	Saturday	SAT
East	E	Service Road	SERV RD
Eastbound	(route) E	Shoulder	SHLDR
Emergency	EMER	Slippery	SLIP
Emergency Vehicle	EMER VEH	South	S
Entrance, Enter	ENT	Southbound	(route) S
Express Lane	EXP LN	Speed	SPD
Expressway	EXPWY	Street	ST
XXXX Feet	XXXX FT	Sunday	SUN
Fog Ahead	FOG AHD	Telephone	PHONE
Freeway	FRWY, FWY	Temporary	TEMP
Freeway Blocked	FWY BLKD	Thursday	THURS
Friday	FRI	To Downtown	TO DWNTN
Hazardous Driving	HAZ DRIVING	Traffic	TRAF
Hazardous Material	HAZMAT	Travelers	TRVLR
High-Occupancy Vehicle	HOV	Tuesday	TUES
Highway	HWY	Time Minutes	TIME MIN
Hour(s)	HR, HRS	Upper Level	UPR LEVEL
Information	INFO	Vehicles (s)	VEH, VEHS
It Is	ITS	Warning	WARN
Junction	JCT	Wednesday	WED
Left	LFT	Weight Limit	WT LIMIT
Left Lane	LFT LN	West	W
Lane Closed	LN CLOSED	Westbound	(route) W
Lower Level	LWR LEVEL	Wet Pavement	WET PVMT
Maintenance	MAINT	Will Not	WONT

Roadway designation # IH-number, US-number, SH-number, FM-number

## Phase 1: Condition Lists

### Road/Lane/Ramp Closure List

FREEWAY CLOSED X MILE
ROAD CLOSED AT SH XXX
ROAD CLSD AT FM XXXX
RIGHT X LANES CLOSED
CENTER LANE CLOSED
NIGHT LANE CLOSURES
VARIOUS LANES CLOSED
EXIT CLOSED
MALL DRIVEWAY CLOSED
XXXXXXXX BLVD CLOSED

### Other Condition List

FRONTAGE ROAD CLOSED
SHOULDER CLOSED XXX FT
RIGHT LN CLOSED XXX FT
RIGHT X LANES OPEN
DAYTIME LANE CLOSURES
I-XX SOUTH EXIT CLOSED
EXIT XXX CLOSED X MILE
RIGHT LN TO BE CLOSED
X LANES CLOSED TUE - FRI

\* LANES SHIFT in Phase 1 must be used with STAY IN LANE in Phase 2.

## Phase 2: Possible Component Lists

### Action to Take/Effect on Travel List

MERGE RIGHT
DETOUR NEXT X EXITS
USE EXIT XXX
STAY ON US XXX SOUTH
TRUCKS USE US XXX N
WATCH FOR TRUCKS
EXPECT DELAYS
REDUCE SPEED XXX FT
USE OTHER ROUTES
STAY IN LANE

### Location List

AT FM XXXX
BEFORE RAILROAD CROSSING
NEXT X MILES
PAST US XXX EXIT
XXXXXXXX TO XXXXXX
US XXX TO FM XXXX

### Warning List

SPEED LIMIT XX MPH
MAXIMUM SPEED XX MPH
MINIMUM SPEED XX MPH
ADVISORY SPEED XX MPH
RIGHT LANE EXIT
USE CAUTION
DRIVE SAFELY
DRIVE WITH CARE

### \*\* Advance Notice List

TUE-FRI XX AM-X PM
APR XX-XX X PM-X AM
BEGINS MONDAY
BEGINS MAY XX
MAY X-X XX PM - XX AM
NEXT FRI-SUN
XX AM TO XX PM
NEXT TUE AUG XX
TONIGHT XX PM-XX AM

\*\* See Application Guidelines Note 6.

## APPLICATION GUIDELINES

- Only 1 or 2 phases are to be used on a PCMS.
- The 1st phase (or both) should be selected from the "Road/Lane/Ramp Closure List" and the "Other Condition List".
- A 2nd phase can be selected from the "Action to Take/Effect on Travel, Location, General Warning, or Advance Notice Phase Lists".
- A Location Phase is necessary only if a distance or location is not included in the first phase selected.
- If two PCMS are used in sequence, they must be separated by a minimum of 1000 ft. Each PCMS shall be limited to two phases, and should be understandable by themselves.
- For advance notice, when the current date is within seven days of the actual work date, calendar days should be replaced with days of the week. Advance notification should typically be for no more than one week prior to the work.

## WORDING ALTERNATIVES

- The words RIGHT, LEFT and ALL can be interchanged as appropriate.
- Roadway designations IH, US, SH, FM and LP can be interchanged as appropriate.
- EAST, WEST, NORTH and SOUTH (or abbreviations E, W, N and S) can be interchanged as appropriate.
- Highway names and numbers replaced as appropriate.
- ROAD, HIGHWAY and FREEWAY can be interchanged as needed.
- AHEAD may be used instead of distances if necessary.
- FT and MI, MILE and MILES interchanged as appropriate.
- AT, BEFORE and PAST interchanged as needed.
- Distances or AHEAD can be eliminated from the message if a location phase is used.

PCMS SIGNS WITHIN THE R.O.W. SHALL BE BEHIND GUARDRAIL OR CONCRETE BARRIER OR SHALL HAVE A MINIMUM OF FOUR (4) PLASTIC DRUMS PLACED PERPENDICULAR TO TRAFFIC ON THE UPSTREAM SIDE OF THE PCMS, WHEN EXPOSED TO ONE DIRECTION OF TRAFFIC. WHEN EXPOSED TO TWO WAY TRAFFIC, THE FOUR DRUMS SHOULD BE PLACED WITH ONE DRUM AT EACH OF THE FOUR CORNERS OF THE UNIT.

## FULL MATRIX PCMS SIGNS

- When Full Matrix PCMS signs are used, the character height and legibility/visibility requirements shall be maintained as listed in Note 15 under "PORTABLE CHANGEABLE MESSAGE SIGNS" above.
- When symbol signs, such as the "Flagger Symbol" (CW20-7) are represented graphically on the Full Matrix PCMS sign and, with the approval of the Engineer, it shall maintain the legibility/visibility requirement listed above.
- When symbol signs are represented graphically on the Full Matrix PCMS, they shall only supplement the use of the static sign represented, and shall not substitute for, or replace that sign.
- A full matrix PCMS may be used to simulate a flashing arrow board provided it meets the visibility, flash rate and dimming requirements on BC(7), for the same size arrow.

SHEET 6 OF 12



# BARRICADE AND CONSTRUCTION PORTABLE CHANGEABLE MESSAGE SIGN (PCMS)

BC (6) - 21

FILE: bc-21.dgn	DN: TxDOT	CR: TxDOT	DW: TxDOT	CK: TxDOT
© TxDOT November 2002	CONT	SECT	JOB	HIGHWAY
REVISIONS	6435	38	001	IH10, etc
9-07 8-14	DIST	COUNTY	SHEET NO.	
7-13 5-21	BMT	JEFFERSON, etc	21	

DATE: FILE:

DISCLAIMER: The use of this standard is governed by the "Texas Engineering Practice Act". No warranty of any kind is made by TxDOT for any purpose whatsoever. TxDOT assumes no responsibility for the conversion of this standard to other formats or for incorrect results or damages resulting from its use.

- Barrier Reflectors shall be pre-qualified, and conform to the color and reflectivity requirements of DMS-8600. A list of prequalified Barrier Reflectors can be found at the Material Producer List web address shown on BC(1).
- Color of Barrier Reflectors shall be as specified in the TMUTCD. The cost of the reflectors shall be considered subsidiary to Item 512.

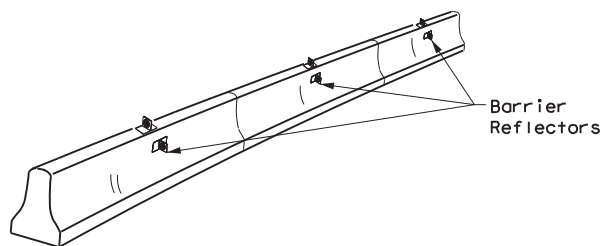

**CONCRETE TRAFFIC BARRIER (CTB)**

- Where traffic is on one side of the CTB, two (2) Barrier Reflectors shall be mounted in approximately the midsection of each section of CTB. An alternate mounting location is uniformly spaced at one end of each CTB. This will allow for attachment of a barrier grapple without damaging the reflector. The Barrier Reflector mounted on the side of the CTB shall be located directly below the reflector mounted on top of the barrier, as shown in the detail above.
- Where CTB separates two-way traffic, three barrier reflectors shall be mounted on each section of CTB. The reflector unit on top shall have two yellow reflective faces (Bi-Directional) while the reflectors on each side of the barrier shall have one yellow reflective face, as shown in the detail above.
- When CTB separates traffic traveling in the same direction, no barrier reflectors will be required on top of the CTB.
- Barrier Reflector units shall be yellow or white in color to match the edgeline being supplemented.
- Maximum spacing of Barrier Reflectors is forty (40) feet.
- Pavement markers or temporary flexible-reflective roadway marker tabs shall NOT be used as CTB delineation.
- Attachment of Barrier Reflectors to CTB shall be per manufacturer's recommendations.
- Missing or damaged Barrier Reflectors shall be replaced as directed by the Engineer.
- Single slope barriers shall be delineated as shown on the above detail.

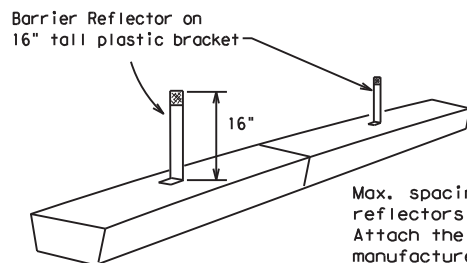

**LOW PROFILE CONCRETE BARRIER (LPCB) USED IN WORK ZONES**

LPCB is approved for use in work zone locations, where the posted speed is 45mph, or less. See Roadway Standard Sheet LPCB.

Max. spacing of barrier reflectors is 20 feet. Attach the delineators as per manufacturer's recommendations.

**LOW PROFILE CONCRETE BARRIER (LPCB)**

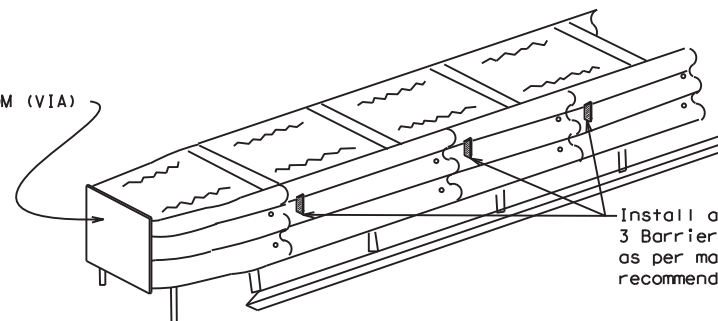

**DELINEATION OF END TREATMENTS**

**END TREATMENTS FOR CTB'S USED IN WORK ZONES**

End treatments used on CTB's in work zones shall meet the appropriate crashworthy standards as defined in the Manual for Assessing Safety Hardware (MASH). Refer to the CWZTCD List for approved end treatments and manufacturers.

**BARRIER REFLECTORS FOR CONCRETE TRAFFIC BARRIER AND ATTENUATORS**

**WARNING LIGHTS**

- Warning lights shall meet the requirements of the TMUTCD.
- Warning lights shall NOT be installed on barricades.
- Type A-Low Intensity Flashing Warning Lights are commonly used with drums. They are intended to warn of or mark a potentially hazardous area. Their use shall be as indicated on this sheet and/or other sheets of the plans by the designation "FL". The Type A Warning Lights shall not be used with signs manufactured with Type B<sub>FL</sub> or C<sub>FL</sub> Sheeting meeting the requirements of Departmental Material Specification DMS-8300.
- Type-C and Type D 360 degree Steady Burn Lights are intended to be used in a series for delineation to supplement other traffic control devices. Their use shall be as indicated on this sheet and/or other sheets of the plans by the designation "SB".
- The Engineer/Inspector or the plans shall specify the location and type of warning lights to be installed on the traffic control devices.
- When required by the Engineer, the Contractor shall furnish a copy of the warning lights certification. The warning light manufacturer will certify the warning lights meet the requirements of the latest ITE Purchase Specifications for Flashing and Steady-Burn Warning Lights.
- When used to delineate curves, Type-C and Type D Steady Burn Lights should only be placed on the outside of the curve, not the inside.
- The location of warning lights and warning reflectors on drums shall be as shown elsewhere in the plans.

**WARNING LIGHTS MOUNTED ON PLASTIC DRUMS**

- Type A flashing warning lights are intended to warn drivers that they are approaching or are in a potentially hazardous area.
- Type A random flashing warning lights are not intended for delineation and shall not be used in a series.
- A series of sequential flashing warning lights placed on channelizing devices to form a merging taper may be used for delineation. If used, the successive flashing of the sequential warning lights should occur from the beginning of the taper to the end of the merging taper in order to identify the desired vehicle path. The rate of flashing for each light shall be 65 flashes per minute, plus or minus 10 flashes.
- Type C and D steady-burn warning lights are intended to be used in a series to delineate the edge of the travel lane on detours, on lane changes, on lane closures, and on other similar conditions.
- Type A, Type C and Type D warning lights shall be installed at locations as detailed on other sheets in the plans.
- Warning lights shall not be installed on a drum that has a sign, chevron or vertical panel.
- The maximum spacing for warning lights on drums should be identical to the channelizing device spacing.

**WARNING REFLECTORS MOUNTED ON PLASTIC DRUMS AS A SUBSTITUTE FOR TYPE C (STEADY BURN) WARNING LIGHTS**

- A warning reflector or approved substitute may be mounted on a plastic drum as a substitute for a Type C, steady burn warning light at the discretion of the Contractor unless otherwise noted in the plans.
- The warning reflector shall be yellow in color and shall be manufactured using a sign substrate approved for use with plastic drums listed on the CWZTCD.
- The warning reflector shall have a minimum retroreflective surface area (one-side) of 30 square inches.
- Round reflectors shall be fully reflectorized, including the area where attached to the drum.
- Square substrates must have a minimum of 30 square inches of reflectorized sheeting. They do not have to be reflectorized where it attaches to the drum.
- The side of the warning reflector facing approaching traffic shall have sheeting meeting the color and retroreflectivity requirements for DMS 8300-Type B or Type C.
- When used near two-way traffic, both sides of the warning reflector shall be reflectorized.
- The warning reflector should be mounted on the side of the handle nearest approaching traffic.
- The maximum spacing for warning reflectors should be identical to the channelizing device spacing requirements.

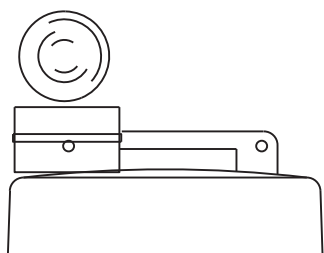

Type C Warning Light or approved substitute mounted on a drum adjacent to the travel way.

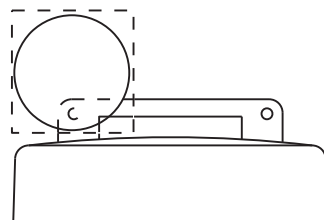

Warning reflector may be round or square. Must have a yellow reflective surface area of at least 30 square inches

Arrow Boards may be located behind channelizing devices in place for a shoulder taper or merging taper, otherwise they shall be delineated with four (4) channelizing devices placed perpendicular to traffic on the upstream side of traffic.

- The Flashing Arrow Board should be used for all lane closures on multi-lane roadways, or slow moving maintenance or construction activities on the travel lanes.
- Flashing Arrow Boards should not be used on two-lane, two-way roadways, detours, diversions or work on shoulders unless the "CAUTION" display (see detail below) is used.
- The Engineer/Inspector shall choose all appropriate signs, barricades and/or other traffic control devices that should be used in conjunction with the Flashing Arrow Board.
- The Flashing Arrow Board should be able to display the following symbols:

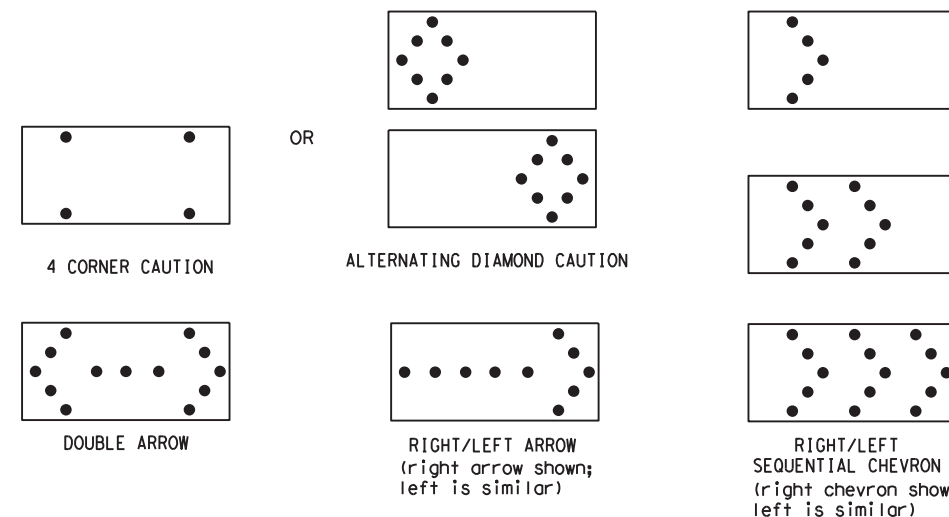

- The "CAUTION" display consists of four corner lamps flashing simultaneously, or the Alternating Diamond Caution mode as shown.
- The straight line caution display is NOT ALLOWED.
- The Flashing Arrow Board shall be capable of minimum 50 percent dimming from rated lamp voltage. The flashing rate of the lamps shall not be less than 25 nor more than 40 flashes per minute.
- Minimum lamp "on time" shall be approximately 50 percent for the flashing arrow and equal intervals of 25 percent for each sequential phase of the flashing chevron.
- The sequential arrow display is NOT ALLOWED.
- The flashing arrow display is the TxDOT standard; however, the sequential chevron display may be used during daylight operations.
- The Flashing Arrow Board shall be mounted on a vehicle, trailer or other suitable support.
- A Flashing Arrow Board SHALL NOT BE USED to laterally shift traffic.
- A full matrix PCMS may be used to simulate a Flashing Arrow Board provided it meets visibility, flash rate and dimming requirements on this sheet for the same size arrow.
- Minimum mounting height of trailer mounted Arrow Boards should be 7 feet from roadway to bottom of panel.

REQUIREMENTS			
TYPE	MINIMUM SIZE	MINIMUM NUMBER OF PANEL LAMPS	MINIMUM VISIBILITY DISTANCE
B	30 x 60	13	3/4 mile
C	48 x 96	15	1 mile

**ATTENTION**  
Flashing Arrow Boards shall be equipped with automatic dimming devices.

WHEN NOT IN USE, REMOVE THE ARROW BOARD FROM THE RIGHT-OF-WAY OR PLACE THE ARROW BOARD BEHIND CONCRETE TRAFFIC BARRIER OR GUARDRAIL.

**FLASHING ARROW BOARDS**

SHEET 7 OF 12

**TRUCK-MOUNTED ATTENUATORS**

- Truck-mounted attenuators (TMA) used on TxDOT facilities must meet the requirements outlined in the Manual for Assessing Safety Hardware (MASH).
- Refer to the CWZTCD for the requirements of Level 2 or Level 3 TMAs.
- Refer to the CWZTCD for a list of approved TMAs.
- TMAs are required on freeways unless otherwise noted in the plans.
- A TMA should be used anytime that it can be positioned 30 to 100 feet in advance of the area of crew exposure without adversely affecting the work performance.
- The only reason a TMA should not be required is when a work area is spread down the roadway and the work crew is an extended distance from the TMA.



**BARRICADE AND CONSTRUCTION ARROW PANEL, REFLECTORS, WARNING LIGHTS & ATTENUATOR**

**BC (7) -21**

FILE:	bc-21.dgn	DN:	TxDOT	CR:	TxDOT	OW:	TxDOT	CK:	TxDOT
© TxDOT	November 2002	CONT	SECT	JOB	HIGHWAY				
REVISIONS		6435	38	001	IH10, etc				
9-07	8-14	DIST	COUNTY	SHEET NO.					
7-13	5-21	BMT	JEFFERSON, etc	22					

DATE:  
FILE:

DISCLAIMER: The use of this standard is governed by the "Texas Engineering Practice Act". No warranty of any kind is made by TxDOT for any purpose whatsoever. TxDOT assumes no responsibility for the conversion of this standard to other formats or for incorrect results or damages resulting from its use.

**GENERAL NOTES**

- For long term stationary work zones on freeways, drums shall be used as the primary channelizing device.
- For intermediate term stationary work zones on freeways, drums should be used as the primary channelizing device but may be replaced in tangent sections by vertical panels, or 42" two-piece cones. In tangent sections, one-piece cones may be used with the approval of the Engineer but only if personnel are present on the project at all times to maintain the cones in proper position and location.
- For short term stationary work zones on freeways, drums are the preferred channelizing device but may be replaced in tapers, transitions and tangent sections by vertical panels, two-piece cones or one-piece cones as approved by the Engineer.
- Drums and all related items shall comply with the requirements of the current version of the "Texas Manual on Uniform Traffic Control Devices" (TMUTCD) and the "Compliant Work Zone Traffic Control Devices List" (CWZTCD).
- Drums, bases, and related materials shall exhibit good workmanship and shall be free from objectionable marks or defects that would adversely affect their appearance or serviceability.
- The Contractor shall have a maximum of 24 hours to replace any plastic drums identified for replacement by the Engineer/Inspector. The replacement device must be an approved device.

**GENERAL DESIGN REQUIREMENTS**

Pre-qualified plastic drums shall meet the following requirements:

- Plastic drums shall be a two-piece design; the "body" of the drum shall be the top portion and the "base" shall be the bottom.
- The body and base shall lock together in such a manner that the body separates from the base when impacted by a vehicle traveling at a speed of 20 MPH or greater but prevents accidental separation due to normal handling and/or air turbulence created by passing vehicles.
- Plastic drums shall be constructed of lightweight flexible, and deformable materials. The Contractor shall NOT use metal drums or single piece plastic drums as channelization devices or sign supports.
- Drums shall present a profile that is a minimum of 18 inches in width at the 36 inch height when viewed from any direction. The height of drum unit (body installed on base) shall be a minimum of 36 inches and a maximum of 42 inches.
- The top of the drum shall have a built-in handle for easy pickup and shall be designed to drain water and not collect debris. The handle shall have a minimum of two widely spaced 9/16 inch diameter holes to allow attachment of a warning light, warning reflector unit or approved compliant sign.
- The exterior of the drum body shall have a minimum of four alternating orange and white retroreflective circumferential stripes not less than 4 inches nor greater than 8 inches in width. Any non-reflectORIZED space between any two adjacent stripes shall not exceed 2 inches in width.
- Bases shall have a maximum width of 36 inches, a maximum height of 4 inches, and a minimum of two footholds of sufficient size to allow base to be held down while separating the drum body from the base.
- Plastic drums shall be constructed of ultra-violet stabilized, orange, high-density polyethylene (HDPE) or other approved material.
- Drum body shall have a maximum unballasted weight of 11 lbs.
- Drum and base shall be marked with manufacturer's name and model number.

**RETROREFLECTIVE SHEETING**

- The stripes used on drums shall be constructed of sheeting meeting the color and retroreflectivity requirements of Departmental Materials Specification DMS-8300, "Sign Face Materials." Type A or Type B reflective sheeting shall be supplied unless otherwise specified in the plans.
- The sheeting shall be suitable for use on and shall adhere to the drum surface such that, upon vehicular impact, the sheeting shall remain adhered in-place and exhibit no delaminating, cracking, or loss of retroreflectivity other than that loss due to abrasion of the sheeting surface.

**BALLAST**

- Unballasted bases shall be large enough to hold up to 50 lbs. of sand. This base, when filled with the ballast material, should weigh between 35 lbs (minimum) and 50 lbs (maximum). The ballast may be sand in one to three sandbags separate from the base, sand in a sand-filled plastic base, or other ballasting devices as approved by the Engineer. Stacking of sandbags will be allowed, however height of sandbags above pavement surface may not exceed 12 inches.
- Bases with built-in ballast shall weigh between 40 lbs. and 50 lbs. Built-in ballast can be constructed of an integral crumb rubber base or a solid rubber base.
- Recycled truck tire sidewalls may be used for ballast on drums approved for this type of ballast on the CWZTCD list.
- The ballast shall not be heavy objects, water, or any material that would become hazardous to motorists, pedestrians, or workers when the drum is struck by a vehicle.
- When used in regions susceptible to freezing, drums shall have drainage holes in the bottoms so that water will not collect and freeze becoming a hazard when struck by a vehicle.
- Ballast shall not be placed on top of drums.
- Adhesives may be used to secure base of drums to pavement.

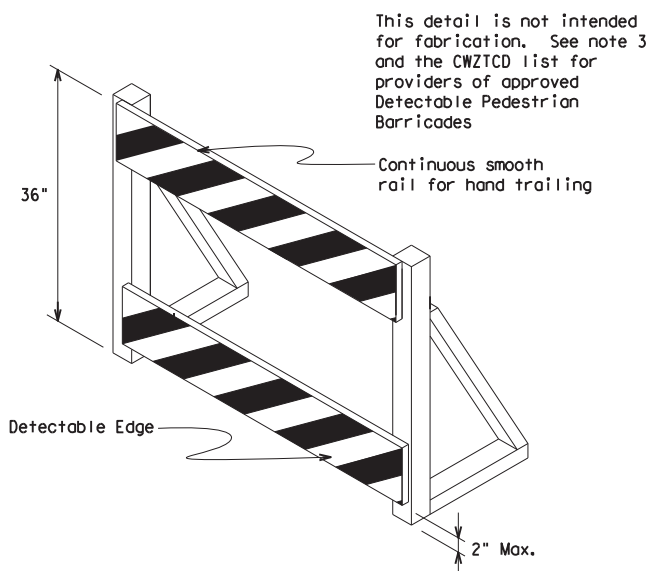
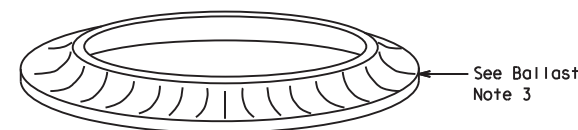
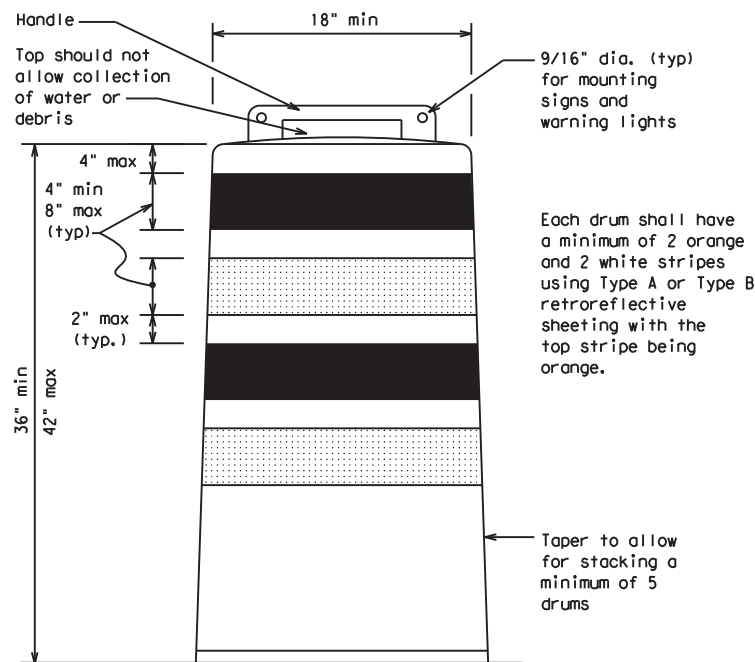

**DETECTABLE PEDESTRIAN BARRICADES**

- When existing pedestrian facilities are disrupted, closed, or relocated in a TTC zone, the temporary facilities shall be detectable and include accessibility features consistent with the features present in the existing pedestrian facility. Refer to WZ(BTS-2) for Pedestrian Control requirements for Sidewalk Diversions, Sidewalk Detours and Crosswalk Closures.
- Where pedestrians with visual disabilities normally use the closed sidewalk, a Detectable Pedestrian Barricade shall be placed across the full width of the closed sidewalk instead of a Type 3 Barricade.
- Detectable pedestrian barricades similar to the one pictured above, longitudinal channelizing devices, some concrete barriers, and wood or chain link fencing with a continuous detectable edging can satisfactorily delineate a pedestrian path.
- Tape, rope, or plastic chain strung between devices are not detectable, do not comply with the design standards in the "Americans with Disabilities Act Accessibility Guidelines (ADAAG)" and should not be used as a control for pedestrian movements.
- Warning lights shall not be attached to detectable pedestrian barricades.
- Detectable pedestrian barricades should use 8" nominal barricade rails as shown on BC(10) provided that the top rail provides a smooth continuous rail suitable for hand trailing with no splinters, burrs, or sharp edges.



18" x 24" Sign  
(Maximum Sign Dimension)  
Chevron CW1-8, Opposing Traffic Lane  
Divider, Driveway sign D70a, Keep Right  
R4 series or other signs as approved  
by Engineer



12" x 24"  
Vertical Panel  
mount with diagonals  
sloping down towards  
travel way

Plywood, Aluminum or Metal sign  
substrates shall NOT be used on  
plastic drums

**SIGNS, CHEVRONS, AND VERTICAL PANELS MOUNTED ON PLASTIC DRUMS**

- Signs used on plastic drums shall be manufactured using substrates listed on the CWZTCD.
- Chevrons and other work zone signs with an orange background shall be manufactured with Type B<sub>FL</sub> or Type C<sub>FL</sub> Orange sheeting meeting the color and retroreflectivity requirements of DMS-8300, "Sign Face Material," unless otherwise specified in the plans.
- Vertical Panels shall be manufactured with orange and white sheeting meeting the requirements of DMS-8300 Type A or Type B. Diagonal stripes on Vertical Panels shall slope down toward the intended traveled lane.
- Other sign messages (text or symbolic) may be used as approved by the Engineer. Sign dimensions shall not exceed 18 inches in width or 24 inches in height, except for the R9 series signs discussed in note 8 below.
- Signs shall be installed using a 1/2 inch bolt (nominal) and nut, two washers, and one locking washer for each connection.
- Mounting bolts and nuts shall be fully engaged and adequately torqued. Bolts should not extend more than 1/2 inch beyond nuts.
- Chevrons may be placed on drums on the outside of curves, on merging tapers or on shifting tapers. When used in these locations, they may be placed on every drum or spaced not more than on every third drum. A minimum of three (3) should be used at each location called for in the plans.
- R9-9, R9-10, R9-11 and R9-11a Sidewalk Closed signs which are 24 inches wide may be mounted on plastic drums, with approval of the Engineer.

SHEET 8 OF 12



**BARRICADE AND CONSTRUCTION CHANNELIZING DEVICES**

**BC (8) - 21**

FILE:	bc-21.dgn	DW:	TxDOT	CK:	TxDOT	DW:	TxDOT	CK:	TxDOT
© TxDOT	November 2002	CONT	6435	SECT	38	JOB	001	HIGHWAY	IH10, etc
REVISIONS		DIST	COUNTY		SHEET NO.				
4-03	8-14	BMT	JEFFERSON, etc		23				
9-07	5-21								
7-13									

DATE:  
FILE:

DISCLAIMER: The use of this standard is governed by the "Texas Engineering Practice Act". No warranty of any kind is made by TxDOT for any purpose whatsoever. TxDOT assumes no responsibility for the conversion of this standard to other formats or for incorrect results or damages resulting from its use.

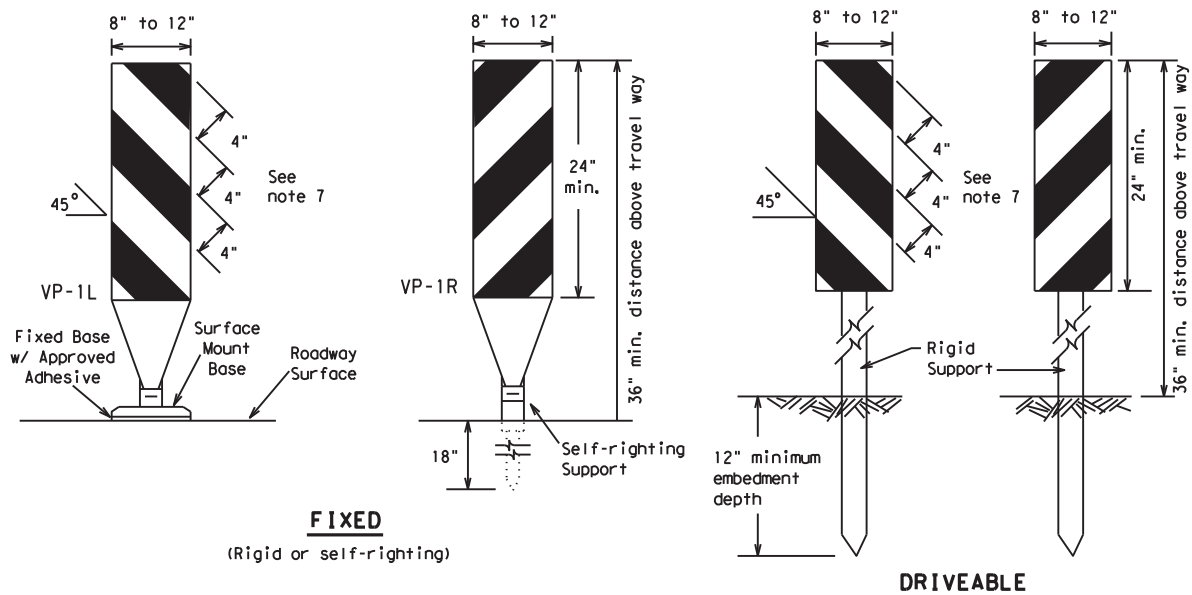

**FIXED**  
(Rigid or self-righting)

**DRIVEABLE**

- Vertical Panels (VP's) are normally used to channelize traffic or divide opposing lanes of traffic.
- VP's may be used in daytime or nighttime situations. They may be used at the edge of shoulder drop-offs and other areas such as lane transitions where positive daytime and nighttime delineation is required. The Engineer/Inspector shall refer to the Roadway Design Manual for additional requirements on the use VP's for drop-offs.
- VP's should be mounted back to back if used at the edge of cuts adjacent to two-way two lane roadways. Stripes are to be reflective orange and reflective white and should always slope downward toward the travel lane.
- VP's used on expressways and freeways or other high speed roadways, may have more than 270 square inches of retroreflective area facing traffic.
- Self-righting supports are available with portable base. See "Compliant Work Zone Traffic Control Devices List" (CWZTCD).
- Sheeting for the VP's shall be retroreflective Type A or Type B conforming to Departmental Material Specification DMS-8300, unless noted otherwise.
- Where the height of reflective material on the vertical panel is 36 inches or greater, a panel stripe of 6 inches shall be used.

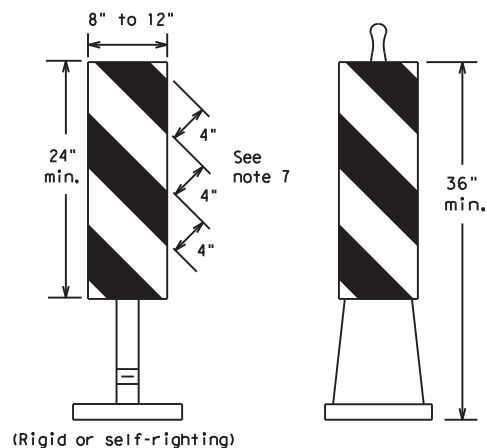

**PORTABLE**

**VERTICAL PANELS (VPs)**

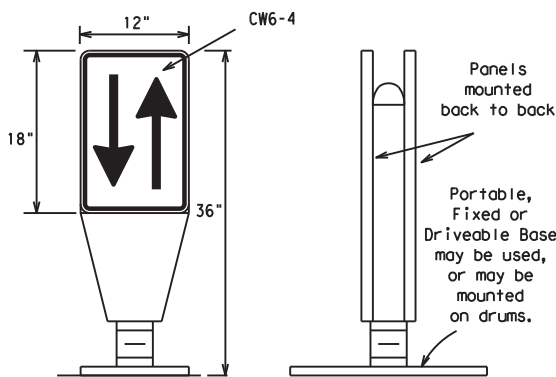

**OPPOSING TRAFFIC LANE DIVIDERS (OTLD)**

- Opposing Traffic Lane Dividers (OTLD) are delineation devices designed to convert a normal one-way roadway section to two-way operation. OTLD's are used on temporary centerlines. The upward and downward arrows on the sign's face indicate the direction of traffic on either side of the divider. The base is secured to the pavement with an adhesive or rubber weight to minimize movement caused by a vehicle impact or wind gust.
- The OTLD may be used in combination with 42" cones or VPs.
- Spacing between the OTLD shall not exceed 500 feet. 42" cones or VPs placed between the OTLD's should not exceed 100 foot spacing.
- The OTLD shall be orange with a black non-reflective legend. Sheeting for the OTLD shall be retroreflective Type B<sub>FL</sub> or Type C<sub>FL</sub> conforming to Departmental Material Specification DMS-8300, unless noted otherwise. The legend shall meet the requirements of DMS-8300.

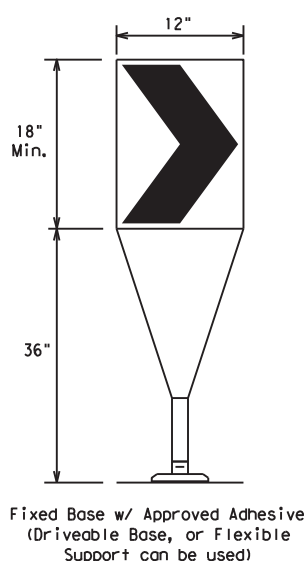

Fixed Base w/ Approved Adhesive (Driveable Base, or Flexible Support can be used)

- The chevron shall be a vertical rectangle with a minimum size of 12 by 18 inches.
- Chevrons are intended to give notice of a sharp change of alignment with the direction of travel and provide additional emphasis and guidance for vehicle operators with regard to changes in horizontal alignment of the roadway.
- Chevrons, when used, shall be erected on the outside of a sharp curve or turn, or on the far side of an intersection. They shall be in line with and at right angles to approaching traffic. Spacing should be such that the motorist always has three in view, until the change in alignment eliminates its need.
- To be effective, the chevron should be visible for at least 500 feet.
- Chevrons shall be orange with a black nonreflective legend. Sheeting for the chevron shall be retroreflective Type B<sub>FL</sub> or Type C<sub>FL</sub> conforming to Departmental Material Specification DMS-8300, unless noted otherwise. The legend shall meet the requirements of DMS-8300.
- For Long Term Stationary use on tapers or transitions on freeways and divided highways, self-righting chevrons may be used to supplement plastic drums but not to replace plastic drums.

**CHEVRONS**

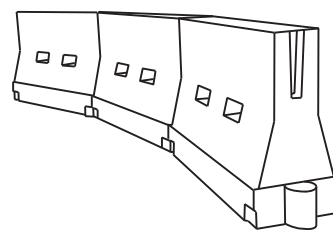

**LONGITUDINAL CHANNELIZING DEVICES (LCD)**

- LCDs are crashworthy, lightweight, deformable devices that are highly visible, have good target value and can be connected together. They are not designed to contain or redirect a vehicle on impact.
- LCDs may be used instead of a line of cones or drums.
- LCDs shall be placed in accordance to application and installation requirements specific to the device, and used only when shown on the CWZTCD list.
- LCDs should not be used to provide positive protection for obstacles, pedestrians or workers.
- LCDs shall be supplemented with retroreflective delineation as required for temporary barriers on BC(7) when placed roughly parallel to the travel lanes.
- LCDs used as barricades placed perpendicular to traffic should have at least one row of reflective sheeting meeting the requirements for barricade rails as shown on BC(10). Place reflective sheeting near the top of the LCD along the full length of the device.

**WATER BALLASTED SYSTEMS USED AS BARRIERS**

- Water ballasted systems used as barriers shall not be used solely to channelize road users, but also to protect the work space per the appropriate Manual for Assessing Safety Hardware (MASH) crashworthiness requirements based on roadway speed and barrier application.
- Water ballasted systems used to channelize vehicular traffic shall be supplemented with retroreflective delineation or channelizing devices to improve daytime/nighttime visibility. They may also be supplemented with pavement markings.
- Water ballasted systems used as barriers shall be placed in accordance to application and installation requirements specific to the device, and used only when shown on the CWZTCD list.
- Water ballasted systems used as barriers should not be used for a merging taper except in low speed (less than 45 MPH) urban areas. When used on a taper in a low speed urban area, the taper shall be delineated and the taper length should be designed to optimize road user operations considering the available geometric conditions.
- When water ballasted systems used as barriers have blunt ends exposed to traffic, they should be attenuated as per manufacturer recommendations or flared to a point outside the clear zone.

If used to channelize pedestrians, longitudinal channelizing devices or water ballasted systems must have a continuous detectable bottom for users of long canes and the top of the unit shall not be less than 32 inches in height.

**HOLLOW OR WATER BALLASTED SYSTEMS USED AS LONGITUDINAL CHANNELIZING DEVICES OR BARRIERS**

**GENERAL NOTES**

- Work Zone channelizing devices illustrated on this sheet may be installed in close proximity to traffic and are suitable for use on high or low speed roadways. The Engineer/Inspector shall ensure that spacing and placement is uniform and in accordance with the "Texas Manual on Uniform Traffic Control Devices" (TMUTCD).
- Channelizing devices shown on this sheet may have a driveable, fixed or portable base. The requirement for self-righting channelizing devices must be specified in the General Notes or other plan sheets.
- Channelizing devices on self-righting supports should be used in work zone areas where channelizing devices are frequently impacted by errant vehicles or vehicle related wind gusts making alignment of the channelizing devices difficult to maintain. Locations of these devices shall be detailed elsewhere in the plans. These devices shall conform to the TMUTCD and the "Compliant Work Zone Traffic Control Devices List" (CWZTCD).
- The Contractor shall maintain devices in a clean condition and replace damaged, nonreflective, faded, or broken devices and bases as required by the Engineer/Inspector. The Contractor shall be required to maintain proper device spacing and alignment.
- Portable bases shall be fabricated from virgin and/or recycled rubber. The portable bases shall weigh a minimum of 30 lbs.
- Pavement surfaces shall be prepared in a manner that ensures proper bonding between the adhesives, the fixed mount bases and the pavement surface. Adhesives shall be prepared and applied according to the manufacturer's recommendations.
- The installation and removal of channelizing devices shall not cause detrimental effects to the final pavement surfaces, including pavement surface discoloration or surface integrity. Driveable bases shall not be permitted on final pavement surfaces. The Engineer/Inspector shall approve all application and removal procedures of fixed bases.

Posted Speed	Formula	Minimum Desirable Taper Lengths **			Suggested Maximum Spacing of Channelizing Devices	
		10' Offset	11' Offset	12' Offset	On a Taper	On a Tangent
30	L = WS <sup>2</sup> / 60	150'	165'	180'	30'	60'
35		205'	225'	245'	35'	70'
40		265'	295'	320'	40'	80'
45	L = WS	450'	495'	540'	45'	90'
50		500'	550'	600'	50'	100'
55		550'	605'	660'	55'	110'
60		600'	660'	720'	60'	120'
65		650'	715'	780'	65'	130'
70		700'	770'	840'	70'	140'
75		750'	825'	900'	75'	150'
80		800'	880'	960'	80'	160'

\*\*Taper lengths have been rounded off.  
L=Length of Taper (FT.) W=Width of Offset (FT.)  
S=Posted Speed (MPH)

**SUGGESTED MAXIMUM SPACING OF CHANNELIZING DEVICES AND MINIMUM DESIRABLE TAPER LENGTHS**

SHEET 9 OF 12



**BARRICADE AND CONSTRUCTION CHANNELIZING DEVICES**

**BC (9) - 21**

FILE: bc-21.dgn	DN: TxDOT	CK: TxDOT	DW: TxDOT	CR: TxDOT
© TxDOT November 2002	CONT	SECT	JOB	HIGHWAY
REVISIONS	6435	38	001	IH10, etc
9-07 8-14	DIST	COUNTY	SHEET NO.	
7-13 5-21	BMT	JEFFERSON, etc	24	

DATE: FILE:



DISCLAIMER: The use of this standard is governed by the "Texas Engineering Practice Act". No warranty of any kind is made by TxDOT for any purpose whatsoever. TxDOT assumes no responsibility for the conversion of this standard to other formats or for incorrect results or damages resulting from its use.

**TYPE 3 BARRICADES**

1. Refer to the Compliant Work Zone Traffic Control Devices List (CWZTCD) for details of the Type 3 Barricades and a list of all materials used in the construction of Type 3 Barricades.
2. Type 3 Barricades shall be used at each end of construction projects closed to all traffic.
3. Barricades extending across a roadway should have stripes that slope downward in the direction toward which traffic must turn in detouring. When both right and left turns are provided, the chevron striping may slope downward in both directions from the center of the barricade. Where no turns are provided at a closed road, striping should slope downward in both directions toward the center of roadway.
4. Striping of rails, for the right side of the roadway, should slope downward to the left. For the left side of the roadway, striping should slope downward to the right.
5. Identification markings may be shown only on the back of the barricade rails. The maximum height of letters and/or company logos used for identification shall be 1".
6. Barricades shall not be placed parallel to traffic unless an adequate clear zone is provided.
7. Warning lights shall NOT be installed on barricades.
8. Where barricades require the use of weights to keep from turning over, the use of sandbags with dry, cohesionless sand is recommended. The sandbags will be tied shut to keep the sand from spilling and to maintain a constant weight. Sand bags shall not be stacked in a manner that covers any portion of a barricade rails reflective sheeting. Rock, concrete, iron, steel or other solid objects will NOT be permitted. Sandbags should weigh a minimum of 35 lbs and a maximum of 50 lbs. Sandbags shall be made of a durable material that tears upon vehicular impact. Rubber (such as tire inner tubes) shall not be used for sandbags. Sandbags shall only be placed along or upon the base supports of the device and shall not be suspended above ground level or hung with rope, wire, chains or other fasteners.
9. Sheeting for barricades shall be retroreflective Type A or Type B conforming to Departmental Material Specification DMS-8300 unless otherwise noted.

Barricades shall NOT be used as a sign support.

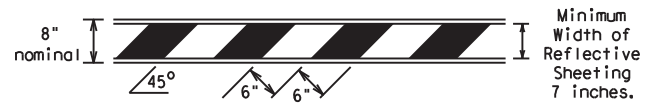

**TYPICAL STRIPING DETAIL FOR BARRICADE RAIL**

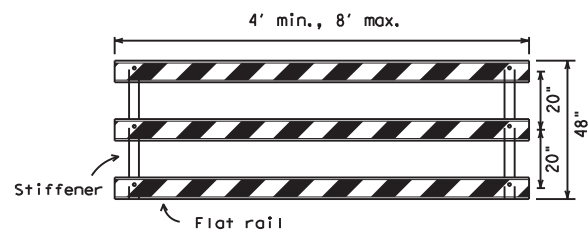

Stiffener may be inside or outside of support, but no more than 2 stiffeners shall be allowed on one barricade.

**TYPICAL PANEL DETAIL FOR SKID OR POST TYPE BARRICADES**

Each roadway of a divided highway shall be barricaded in the same manner.

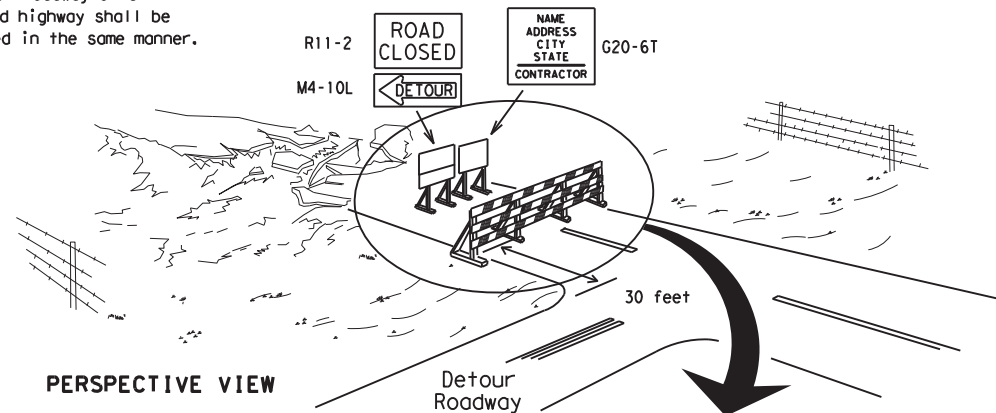

PERSPECTIVE VIEW

The three rails on Type 3 barricades shall be reflectorized orange and reflective white stripes on one side facing one-way traffic and both sides for two-way traffic. Barricade striping should slant downward in the direction of detour.

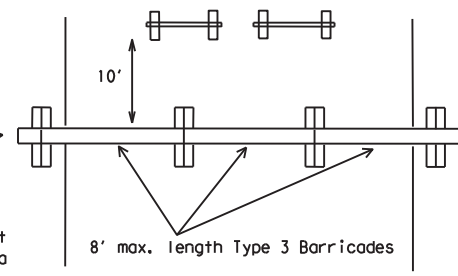

PLAN VIEW

1. Signs should be mounted on independent supports at a 7 foot mounting height in center of roadway. The signs should be a minimum of 10 feet behind Type 3 Barricades.
2. Advance signing shall be as specified elsewhere in the plans.

**TYPE 3 BARRICADE (POST AND SKID) TYPICAL APPLICATION**

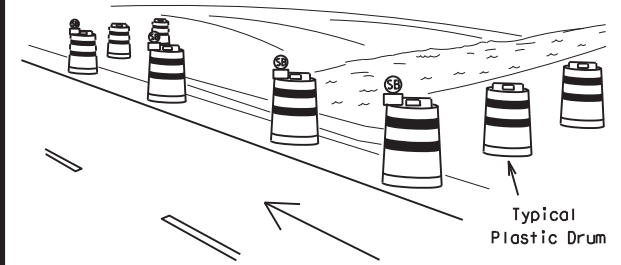

PERSPECTIVE VIEW

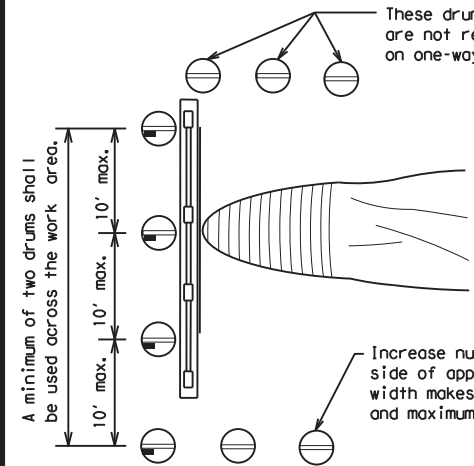

PLAN VIEW

1. Where positive redirection capability is provided, drums may be omitted.
2. Plastic construction fencing may be used with drums for safety as required in the plans.
3. Vertical Panels on flexible support may be substituted for drums when the shoulder width is less than 4 feet.
4. When the shoulder width is greater than 12 feet, steady-burn lights may be omitted if drums are used.
5. Drums must extend the length of the culvert widening.

LEGEND	
	Plastic drum
	Plastic drum with steady burn light or yellow warning reflector
	Steady burn warning light or yellow warning reflector

**CULVERT WIDENING OR OTHER ISOLATED WORK WITHIN THE PROJECT LIMITS**

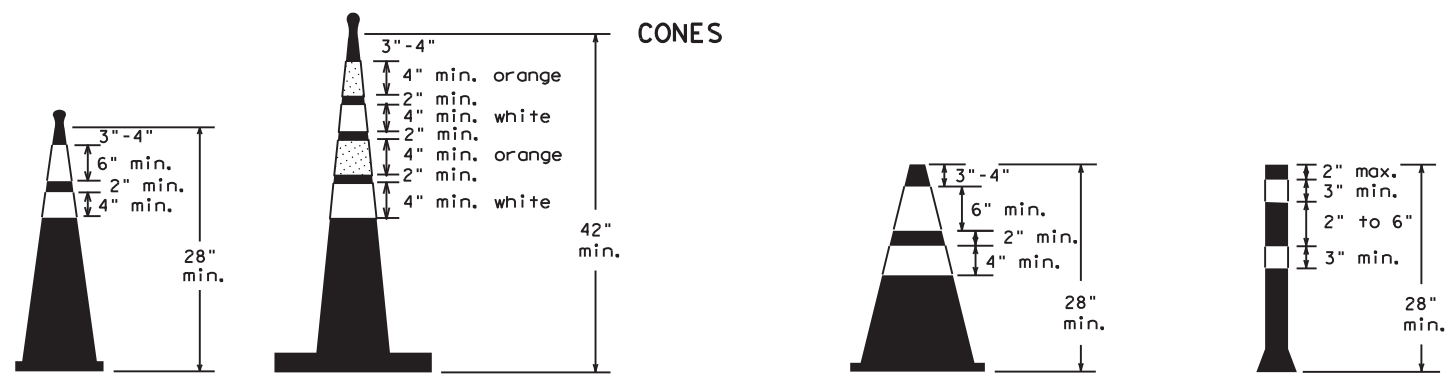

Two-Piece cones

One-Piece cones

Tubular Marker

28" Cones shall have a minimum weight of 9 1/2 lbs.  
42" 2-piece cones shall have a minimum weight of 30 lbs. including base.

1. Traffic cones and tubular markers shall be predominantly orange, and meet the height and weight requirements shown above.
2. One-piece cones have the body and base of the cone molded in one consolidated unit. Two-piece cones have a cone shaped body and a separate rubber base, or ballast, that is added to keep the device upright and in place.
3. Two-piece cones may have a handle or loop extending up to 8" above the minimum height shown, in order to aid in retrieving the device.
4. Cones or tubular markers shall have white or white and orange reflective bands as shown above. The reflective bands shall have a smooth, sealed outer surface and meet the requirements of Departmental Material Specification DMS-8300 Type A or Type B.
5. 28" cones and tubular markers are generally suitable for short duration and short-term stationary work as defined on BC(4). These should not be used for intermediate-term or long-term stationary work unless personnel is on-site to maintain them in their proper upright position.
6. 42" two-piece cones, vertical panels or drums are suitable for all work zone durations.
7. Cones or tubular markers used on each project should be of the same size and shape.

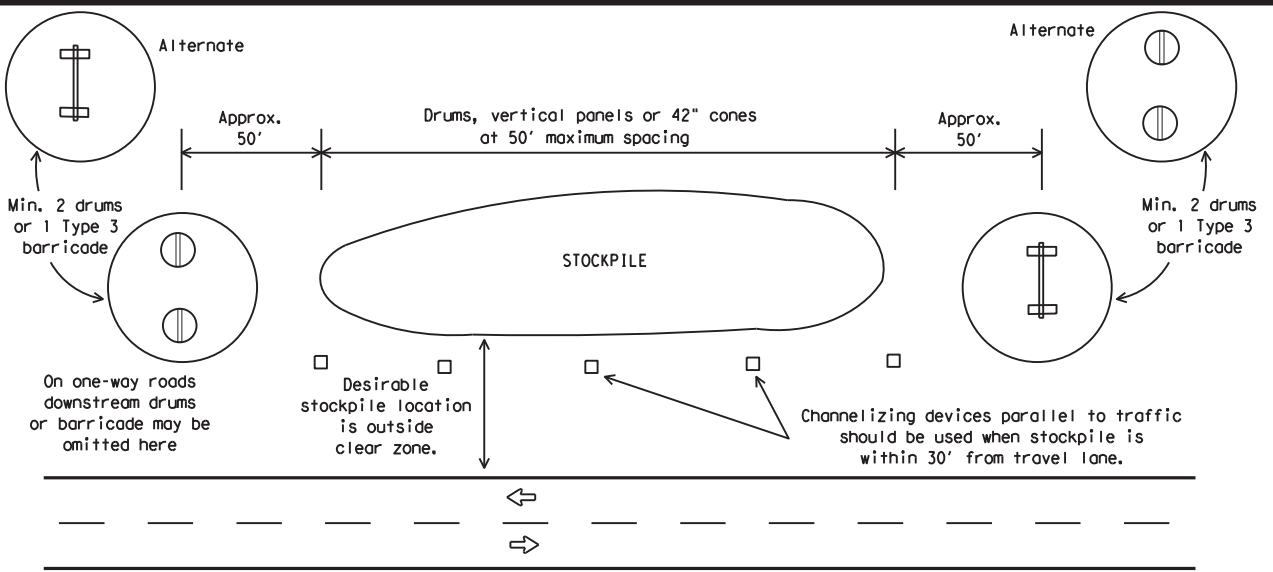

**TRAFFIC CONTROL FOR MATERIAL STOCKPILES**

**BARRICADE AND CONSTRUCTION CHANNELIZING DEVICES**

**BC (10) - 21**

FILE: bc-21.dgn	DN: TxDOT	CR: TxDOT	OW: TxDOT	CK: TxDOT
© TxDOT November 2002	CONT	SECT	JOB	HIGHWAY
REVISIONS	6435	38	001	IH10, etc
9-07 8-14	DIST	COUNTY	SHEET NO.	
7-13 5-21	BMT	JEFFERSON, etc	25	

## WORK ZONE PAVEMENT MARKINGS

### GENERAL

- The Contractor shall be responsible for maintaining work zone and existing pavement markings, in accordance with the standard specifications and special provisions, on all roadways open to traffic within the CSJ limits unless otherwise stated in the plans.
- Color, patterns and dimensions shall be in conformance with the "Texas Manual on Uniform Traffic Control Devices" (TMUTCD).
- Additional supplemental pavement marking details may be found in the plans or specifications.
- Pavement markings shall be installed in accordance with the TMUTCD and as shown on the plans.
- When short term markings are required on the plans, short term markings shall conform with the TMUTCD, the plans and details as shown on the Standard Plan Sheet WZ(STPM).
- When standard pavement markings are not in place and the roadway is opened to traffic, DO NOT PASS signs shall be erected to mark the beginning of the sections where passing is prohibited and PASS WITH CARE signs at the beginning of sections where passing is permitted.
- All work zone pavement markings shall be installed in accordance with Item 662, "Work Zone Pavement Markings."

### RAISED PAVEMENT MARKERS

- Raised pavement markers are to be placed according to the patterns on BC(12).
- All raised pavement markers used for work zone markings shall meet the requirements of Item 672, "RAISED PAVEMENT MARKERS" and Departmental Material Specification DMS-4200 or DMS-4300.

### PREFABRICATED PAVEMENT MARKINGS

- Removable prefabricated pavement markings shall meet the requirements of DMS-8241.
- Non-removable prefabricated pavement markings (foil back) shall meet the requirements of DMS-8240.

### MAINTAINING WORK ZONE PAVEMENT MARKINGS

- The Contractor will be responsible for maintaining work zone pavement markings within the work limits.
- Work zone pavement markings shall be inspected in accordance with the frequency and reporting requirements of work zone traffic control device inspections as required by Form 599.
- The markings should provide a visible reference for a minimum distance of 300 feet during normal daylight hours and 160 feet when illuminated by automobile low-beam headlights at night, unless sight distance is restricted by roadway geometrics.
- Markings failing to meet this criteria within the first 30 days after placement shall be replaced at the expense of the Contractor as per Specification Item 662.

### REMOVAL OF PAVEMENT MARKINGS

- Pavement markings that are no longer applicable, could create confusion or direct a motorist toward or into the closed portion of the roadway shall be removed or obliterated before the roadway is opened to traffic.
- The above shall not apply to detours in place for less than three days, where flaggers and/or sufficient channelizing devices are used in lieu of markings to outline the detour route.
- Pavement markings shall be removed to the fullest extent possible, so as not to leave a discernable marking. This shall be by any method approved by TxDOT Specification Item 677 for "Eliminating Existing Pavement Markings and Markers".
- The removal of pavement markings may require resurfacing or seal coating portions of the roadway as described in Item 677.
- Subject to the approval of the Engineer, any method that proves to be successful on a particular type pavement may be used.
- Blast cleaning may be used but will not be required unless specifically shown in the plans.
- Over-painting of the markings SHALL NOT BE permitted.
- Removal of raised pavement markers shall be as directed by the Engineer.
- Removal of existing pavement markings and markers will be paid for directly in accordance with Item 677, "ELIMINATING EXISTING PAVEMENT MARKINGS AND MARKERS," unless otherwise stated in the plans.
- Black-out marking tape may be used to cover conflicting existing markings for periods less than two weeks when approved by the Engineer.

## Temporary Flexible-Reflective Roadway Marker Tabs

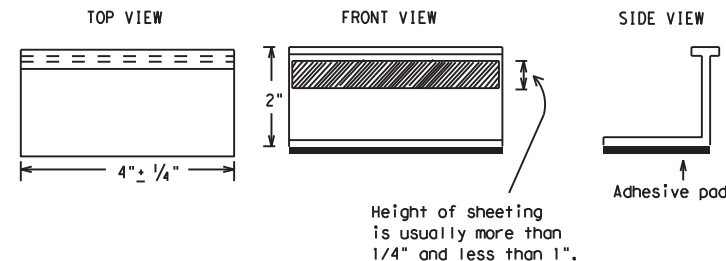

**STAPLES OR NAILS SHALL NOT BE USED TO SECURE  
TEMPORARY FLEXIBLE-REFLECTIVE ROADWAY MARKER  
TABS TO THE PAVEMENT SURFACE**

- Temporary flexible-reflective roadway marker tabs used as guidemarks shall meet the requirements of DMS-8242.
- Tabs detailed on this sheet are to be inspected and accepted by the Engineer or designated representative. Sampling and testing is not normally required, however at the option of the Engineer, either "A" or "B" below may be imposed to assure quality before placement on the roadway.
  - Select five (5) or more tabs at random from each lot or shipment and submit to the Construction Division, Materials and Pavement Section to determine specification compliance.
  - Select five (5) tabs and perform the following test. Affix five (5) tabs at 24 inch intervals on an asphaltic pavement in a straight line. Using a medium size passenger vehicle or pickup, run over the markers with the front and rear tires at a speed of 35 to 40 miles per hour, four (4) times in each direction. No more than one (1) out of the five (5) reflective surfaces shall be lost or displaced as a result of this test.
- Small design variances may be noted between tab manufacturers.
- See Standard Sheet WZ(STPM) for tab placement on new pavements. See Standard Sheet TCP(7-1) for tab placement on seal coat work.

### RAISED PAVEMENT MARKERS USED AS GUIDEMARKS

- Raised pavement markers used as guidemarks shall be from the approved product list, and meet the requirements of DMS-4200.
- All temporary construction raised pavement markers provided on a project shall be of the same manufacturer.
- Adhesive for guidemarks shall be bituminous material hot applied or butyl rubber pad for all surfaces, or thermoplastic for concrete surfaces.

Guidemarks shall be designated as:  
 YELLOW - (two amber reflective surfaces with yellow body).  
 WHITE - (one silver reflective surface with white body).

DEPARTMENTAL MATERIAL SPECIFICATIONS	
PAVEMENT MARKERS (REFLECTORIZED)	DMS-4200
TRAFFIC BUTTONS	DMS-4300
EPOXY AND ADHESIVES	DMS-6100
BITUMINOUS ADHESIVE FOR PAVEMENT MARKERS	DMS-6130
PERMANENT PREFABRICATED PAVEMENT MARKINGS	DMS-8240
TEMPORARY REMOVABLE, PREFABRICATED PAVEMENT MARKINGS	DMS-8241
TEMPORARY FLEXIBLE, REFLECTIVE ROADWAY MARKER TABS	DMS-8242

A list of prequalified reflective raised pavement markers, non-reflective traffic buttons, roadway marker tabs and other pavement markings can be found at the Material Producer List web address shown on BC(1).

SHEET 11 OF 12



## BARRICADE AND CONSTRUCTION PAVEMENT MARKINGS

**BC(11)-21**

FILE: bc-21.dgn	DN: TxDOT	CR: TxDOT	DW: TxDOT	CK: TxDOT
© TxDOT February 1998	CONT	SECT	JOB	HIGHWAY
REVISIONS		6435	38	001
2-98	9-07	5-21		
1-02	7-13			
11-02	8-14			
	DIST	COUNTY	SHEET NO.	
	BMT	JEFFERSON, etc	26	

DISCLAIMER: The use of this standard is governed by the "Texas Engineering Practice Act". No warranty of any kind is made by TxDOT for any purpose whatsoever. TxDOT assumes no responsibility for the conversion of this standard to other formats or for incorrect results or damages resulting from its use.

DATE:  
FILE:

### PAVEMENT MARKING PATTERNS



REFLECTORIZED PAVEMENT MARKINGS - PATTERN A

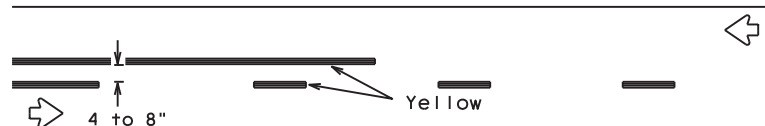

REFLECTORIZED PAVEMENT MARKINGS - PATTERN B

Pattern A is the TXDOT Standard, however Pattern B may be used if approved by the Engineer. Prefabricated markings may be substituted for reflectORIZED pavement markings.

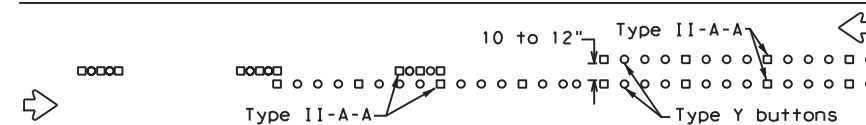

RAISED PAVEMENT MARKERS - PATTERN A

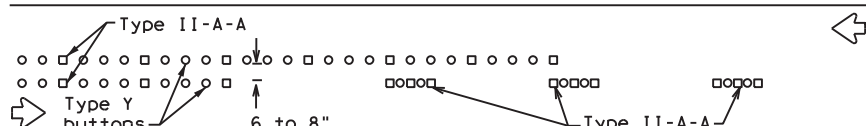

RAISED PAVEMENT MARKERS - PATTERN B

### CENTER LINE & NO-PASSING ZONE BARRIER LINES FOR TWO-LANE, TWO-WAY HIGHWAYS

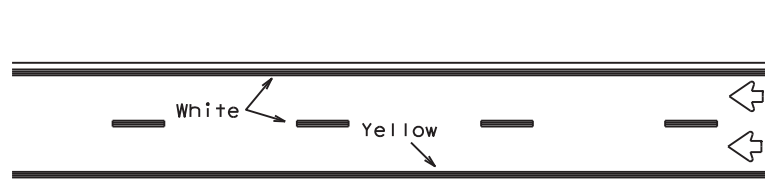

REFLECTORIZED PAVEMENT MARKINGS

Prefabricated markings may be substituted for reflectORIZED pavement markings.

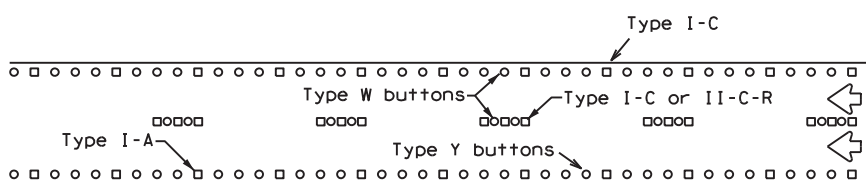

RAISED PAVEMENT MARKERS

### EDGE & LANE LINES FOR DIVIDED HIGHWAY

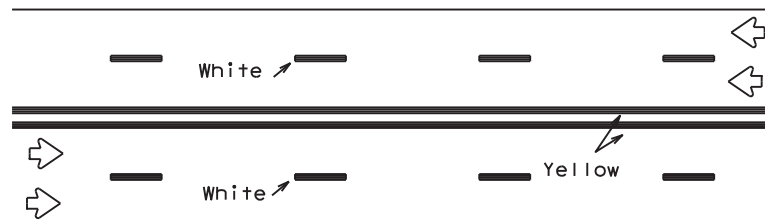

REFLECTORIZED PAVEMENT MARKINGS

Prefabricated markings may be substituted for reflectORIZED pavement markings.

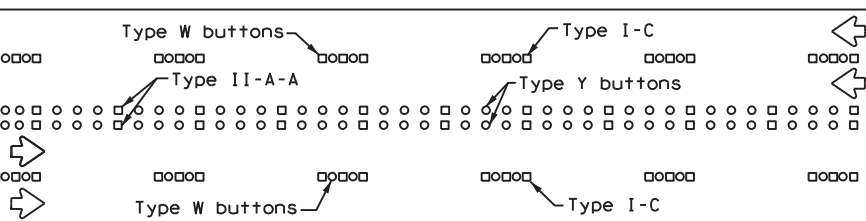

RAISED PAVEMENT MARKERS

### LANE & CENTER LINES FOR MULTILANE UNDIVIDED HIGHWAYS

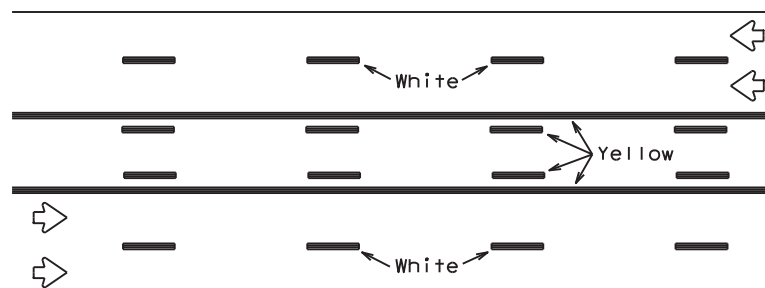

REFLECTORIZED PAVEMENT MARKINGS

Prefabricated markings may be substituted for reflectORIZED pavement markings.

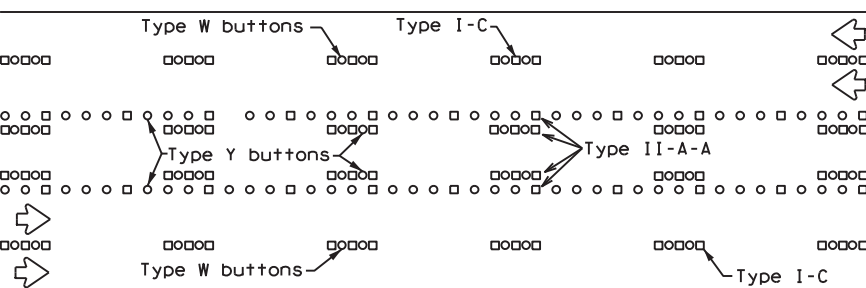

RAISED PAVEMENT MARKERS

### TWO-WAY LEFT TURN LANE

### STANDARD WORK ZONE PAVEMENT MARKINGS DETAILS

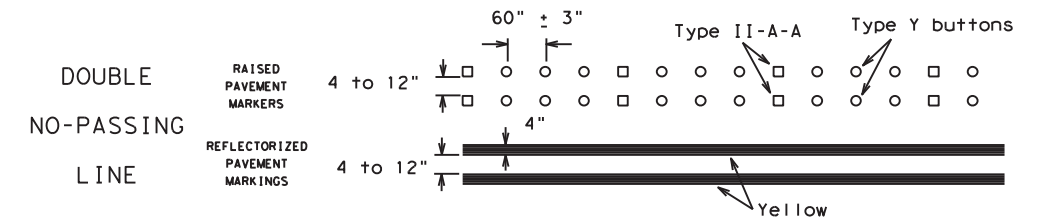

#### SOLID LINES

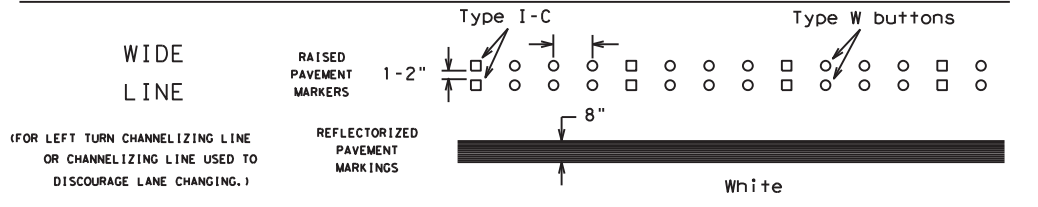
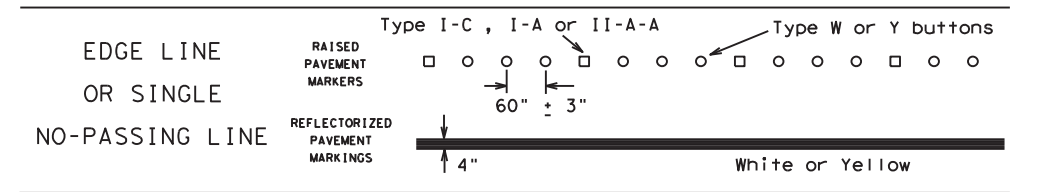

#### BROKEN LINES

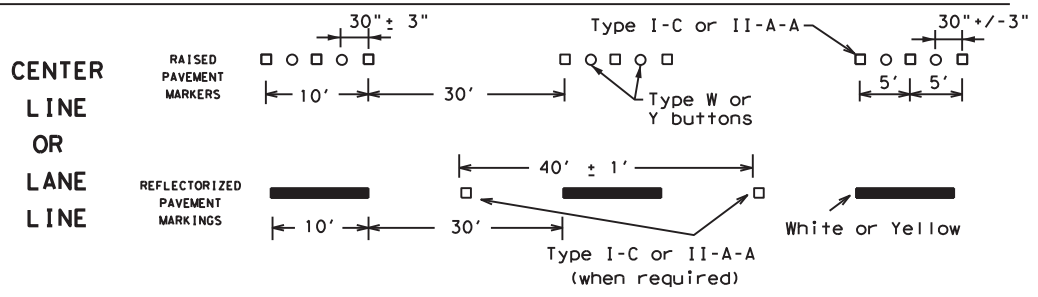

#### AUXILIARY OR LANEDROP LINE

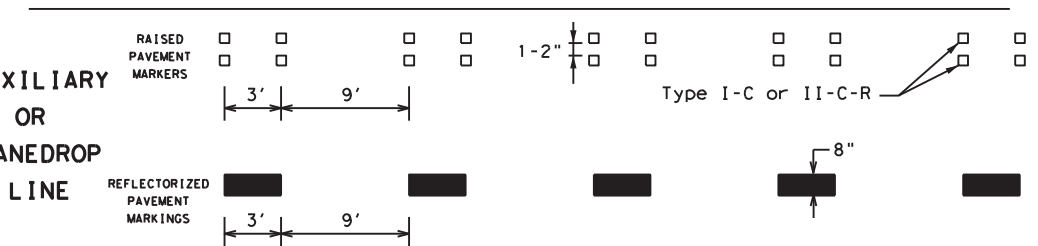

#### REMOVABLE MARKINGS WITH RAISED PAVEMENT MARKERS

If raised pavement markers are used to supplement REMOVABLE markings, the markers shall be applied to the top of the tape at the approximate mid length of tape used for broken lines or at 20 foot spacing for solid lines. This allows an easier removal of raised pavement markers and tape.

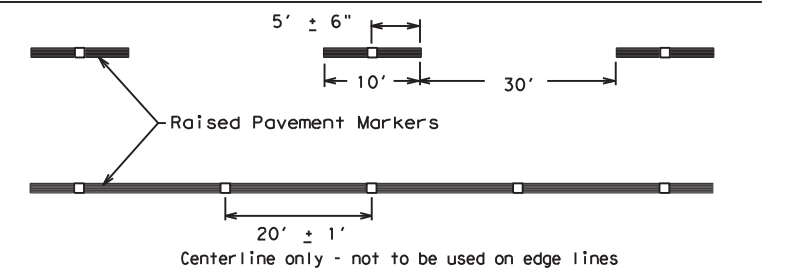

SHEET 12 OF 12



### BARRICADE AND CONSTRUCTION PAVEMENT MARKING PATTERNS

BC(12)-21

Raised pavement markers used as standard pavement markings shall be from the approved products list and meet the requirements of Item 672 "RAISED PAVEMENT MARKERS."

FILE: bc-21.dgn	DN: TxDOT	CK: TxDOT	OW: TxDOT	CR: TxDOT
©TxDOT February 1998	CONT	SECT	JOB	HIGHWAY
REVISIONS	6435	38	001	IH10, etc
1-97 9-07 5-21	DIST	COUNTY	SHEET NO.	
2-98 7-13	BMT	JEFFERSON, etc	27	
11-02 8-14				

DISCLAIMER: The use of this standard is governed by the "Texas Engineering Practice Act". No warranty of any kind is made by TxDOT for any purpose whatsoever. TxDOT assumes no responsibility for the conversion of this standard to other formats or for incorrect results or damages resulting from its use.

DATE: FILE:

DISCLAIMER: The use of this standard is governed by the "Texas Engineering Practice Act". No warranty of any kind is made by TxDOT for any purpose whatsoever. TxDOT assumes no responsibility for the conversion of this standard to other formats or for incorrect results or damages resulting from its use.

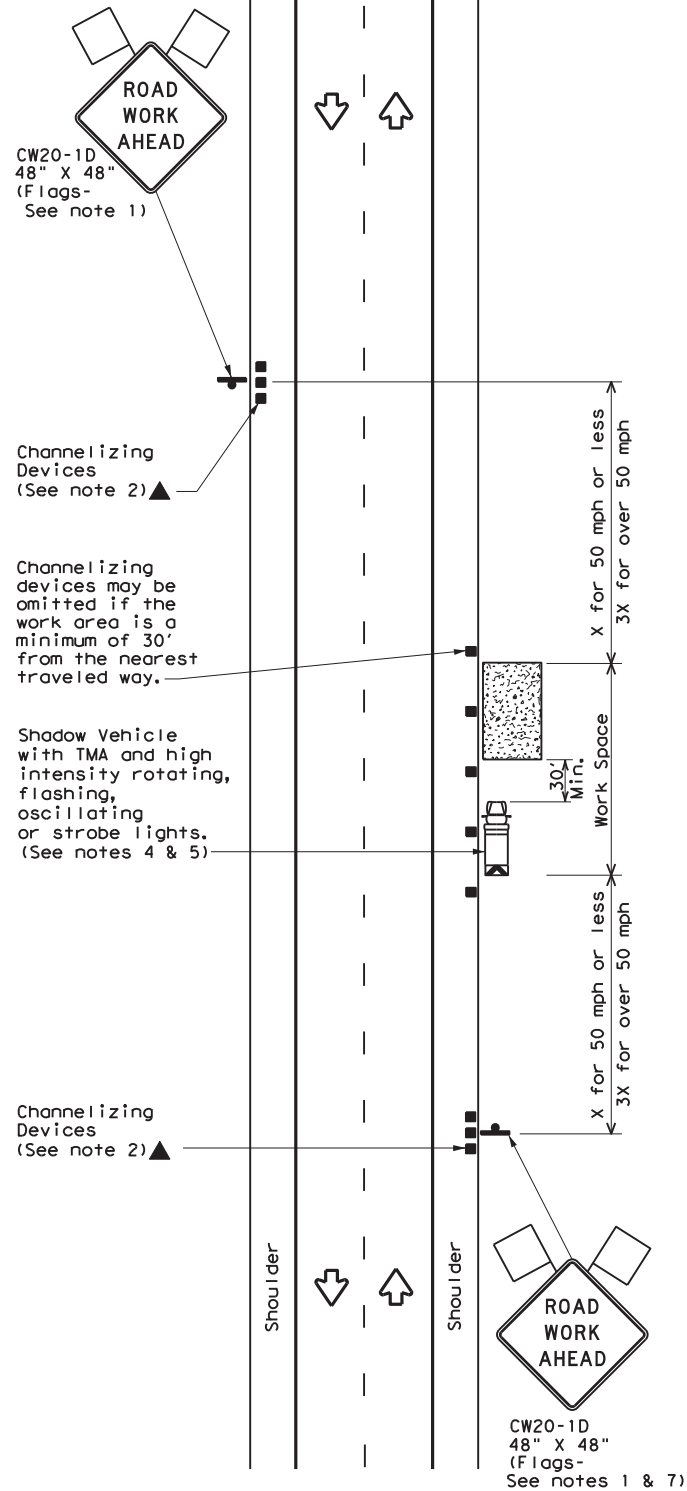

TCP (1-1a)

**WORK SPACE NEAR SHOULDER**  
Conventional Roads

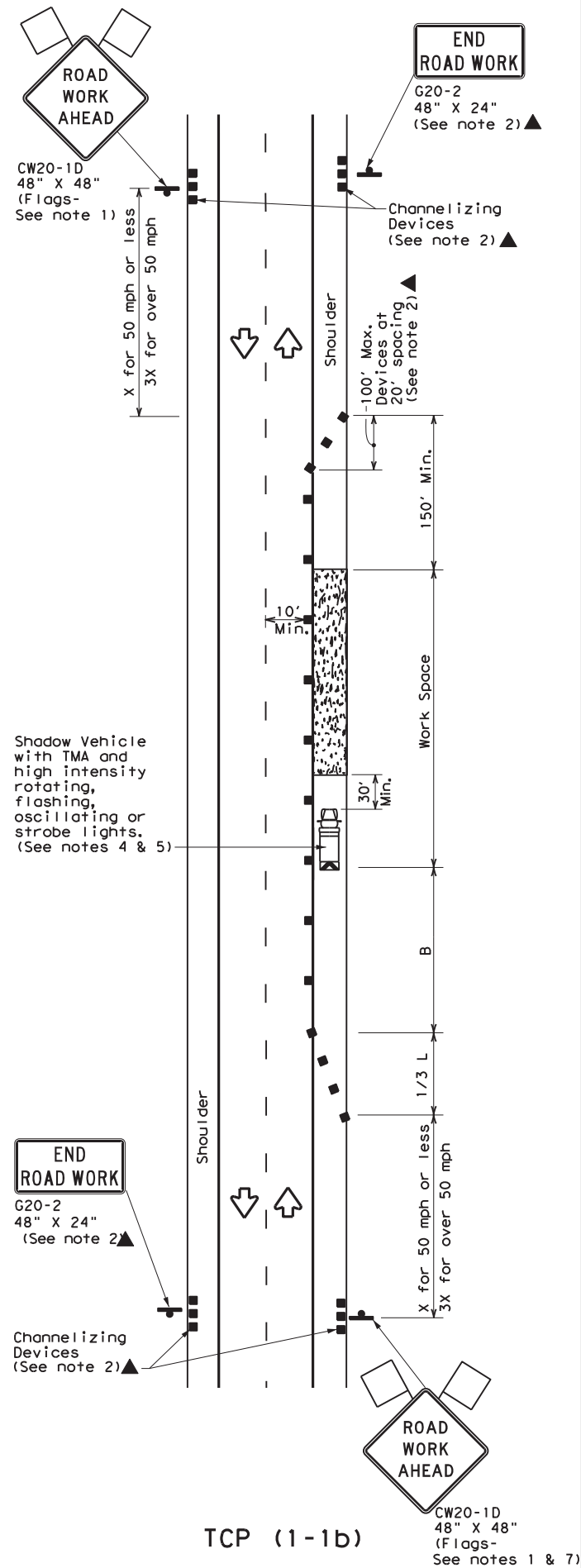

TCP (1-1b)

**WORK SPACE ON SHOULDER**  
Conventional Roads

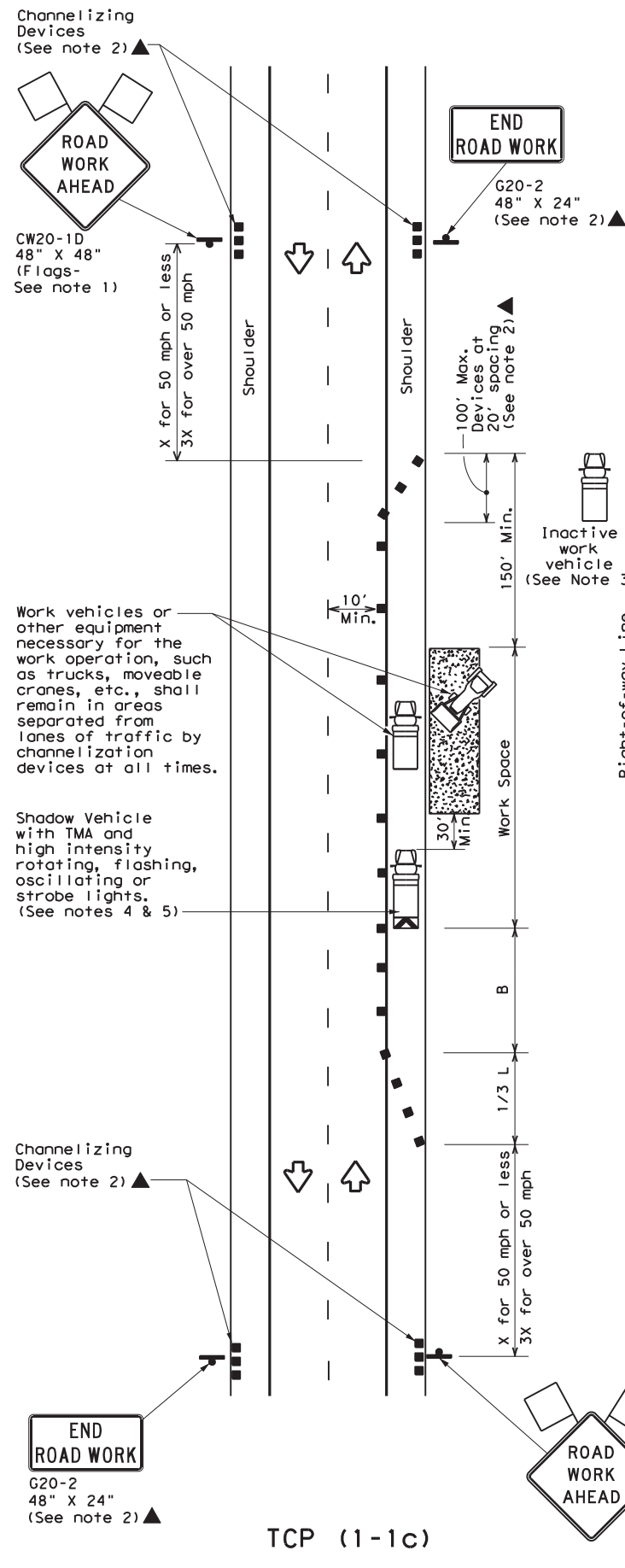

TCP (1-1c)

**WORK VEHICLES ON SHOULDER**  
Conventional Roads

LEGEND			
	Type 3 Barricade		Channelizing Devices
	Heavy Work Vehicle		Truck Mounted Attenuator (TMA)
	Trailer Mounted Flashing Arrow Board		Portable Changeable Message Sign (PCMS)
	Sign		Traffic Flow
	Flag		Flagger

Posted Speed *	Formula	Minimum Desirable Taper Lengths **			Suggested Maximum Spacing of Channelizing Devices		Minimum Sign Spacing "X" Distance	Suggested Longitudinal Buffer Space "B"
		10' Offset	11' Offset	12' Offset	On a Taper	On a Tangent		
30	$L = \frac{WS^2}{60}$	150'	165'	180'	30'	60'	120'	90'
35		205'	225'	245'	35'	70'	160'	120'
40		265'	295'	320'	40'	80'	240'	155'
45	L = WS	450'	495'	540'	45'	90'	320'	195'
50		500'	550'	600'	50'	100'	400'	240'
55		550'	605'	660'	55'	110'	500'	295'
60		600'	660'	720'	60'	120'	600'	350'
65		650'	715'	780'	65'	130'	700'	410'
70		700'	770'	840'	70'	140'	800'	475'
75		750'	825'	900'	75'	150'	900'	540'

\* Conventional Roads Only  
\*\* Taper lengths have been rounded off.  
L=Length of Taper (FT) W=Width of Offset (FT) S=Posted Speed (MPH)

TYPICAL USAGE				
MOBILE	SHORT DURATION	SHORT TERM STATIONARY	INTERMEDIATE TERM STATIONARY	LONG TERM STATIONARY
	✓	✓		

**GENERAL NOTES**

- Flags attached to signs where shown are REQUIRED.
- All traffic control devices illustrated are REQUIRED, except those denoted with the triangle symbol may be omitted when stated elsewhere in the plans, or for routine maintenance work, when approved by the Engineer.
- Inactive work vehicles or other equipment should be parked near the right-of-way line and not parked on the paved shoulder.
- A Shadow Vehicle with a TMA should be used anytime it can be positioned 30 to 100 feet in advance of the area of crew exposure without adversely affecting the performance or quality of the work. If workers are no longer present but road or work conditions require the traffic control to remain in place, Type 3 Barricades or other channelizing devices may be substituted for the Shadow Vehicle and TMA.
- Additional Shadow Vehicles with TMAs may be positioned off the paved surface, next to those shown in order to protect wider work spaces.
- See TCP(5-1) for shoulder work on divided highways, expressways and freeways.
- CW21-5 "SHOULDER WORK" signs may be used in place of CW20-1D "ROAD WORK AHEAD" signs for shoulder work on conventional roadways.



**TRAFFIC CONTROL PLAN**  
**CONVENTIONAL ROAD**  
**SHOULDER WORK**

**TCP(1-1)-18**

FILE: tcp1-1-18.dgn	DN:	CK:	DW:	CK:
© TxDOT December 1985	CONT	SECT	JOB	HIGHWAY
REVISIONS	6435	38	001	IH10, etc
2-94 4-98	DIST	COUNTY	SHEET NO.	
8-95 2-12	BMT	JEFFERSON, etc	28	
1-97 2-18				

DATE:  
FILE:

DISCLAIMER: The use of this standard is governed by the "Texas Engineering Practice Act". No warranty of any kind is made by TxDOT for any purpose whatsoever. TxDOT assumes no responsibility for the conversion of this standard to other formats or for incorrect results or damages resulting from its use.

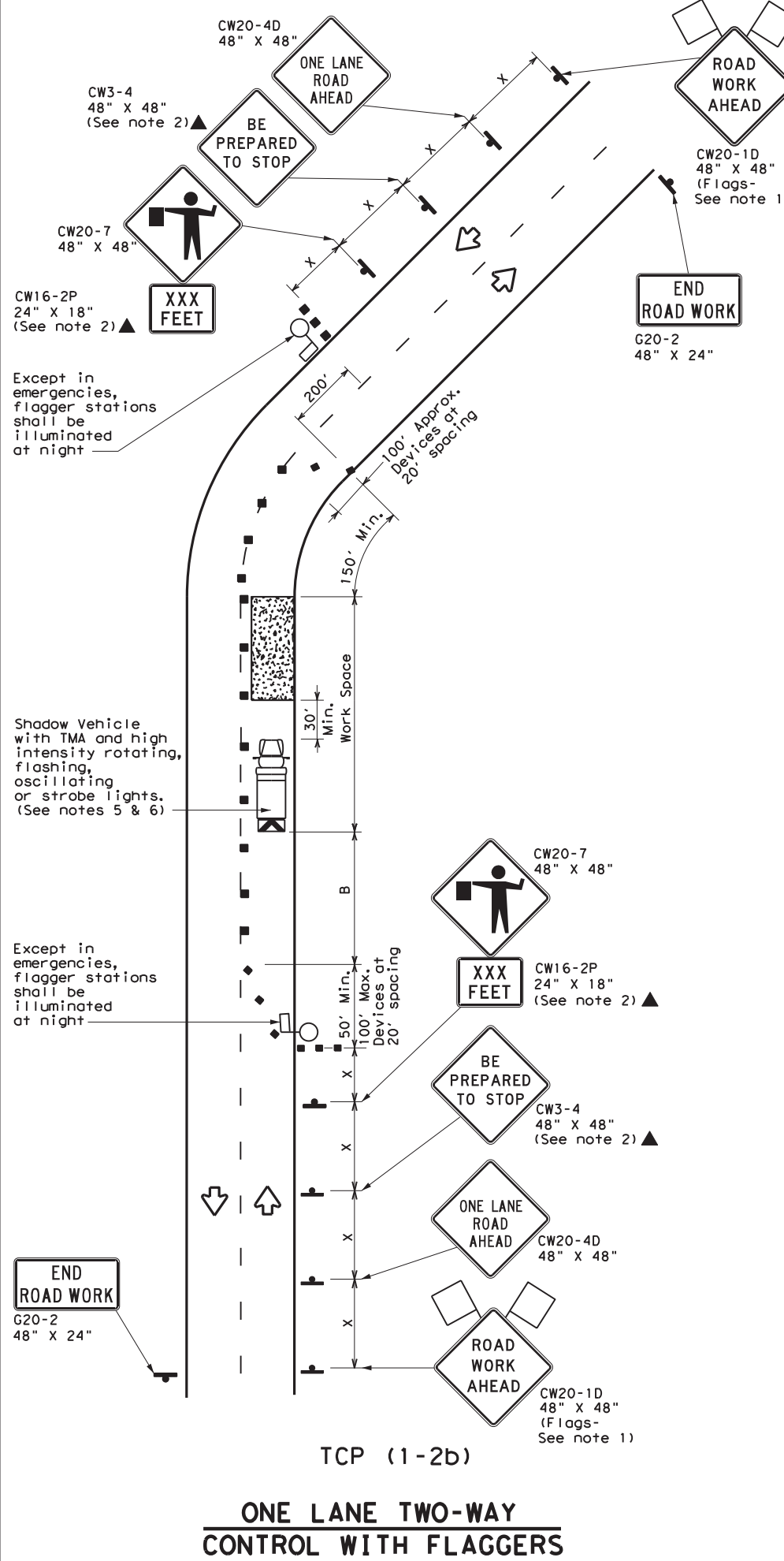
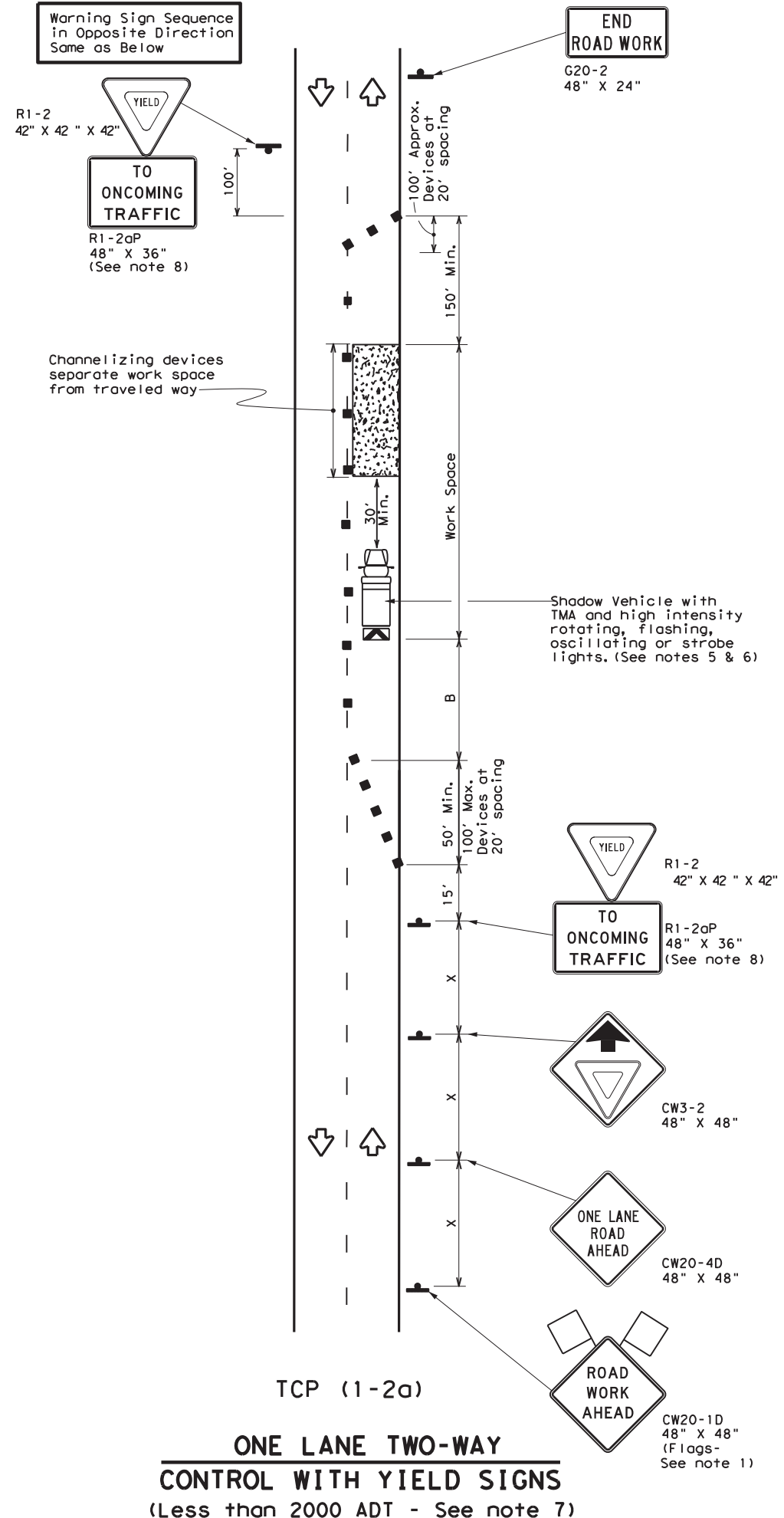

LEGEND			
	Type 3 Barricade		Channelizing Devices
	Heavy Work Vehicle		Truck Mounted Attenuator (TMA)
	Trailer Mounted Flashing Arrow Board		Portable Changeable Message Sign (PCMS)
	Sign		Traffic Flow
	Flag		Flagger

Posted Speed * X	Formula L = WS <sup>2</sup> / 60	Minimum Desirable Taper Lengths **			Suggested Maximum Spacing of Channelizing Devices		Minimum Sign Spacing "X" Distance	Suggested Longitudinal Buffer Space "B"	Stopping Sight Distance
		10' Offset	11' Offset	12' Offset	On a Taper	On a Tangent			
30	L = WS <sup>2</sup> / 60	150'	165'	180'	30'	60'	120'	90'	200'
35		205'	225'	245'	35'	70'	160'	120'	250'
40		265'	295'	320'	40'	80'	240'	155'	305'
45		450'	495'	540'	45'	90'	320'	195'	360'
50	L = WS	500'	550'	600'	50'	100'	400'	240'	425'
55		550'	605'	660'	55'	110'	500'	295'	495'
60		600'	660'	720'	60'	120'	600'	350'	570'
65		650'	715'	780'	65'	130'	700'	410'	645'
70		700'	770'	840'	70'	140'	800'	475'	730'
75		750'	825'	900'	75'	150'	900'	540'	820'

\* Conventional Roads Only  
 \*\* Taper lengths have been rounded off.  
 L=Length of Taper (FT) W=Width of Offset (FT) S=Posted Speed (MPH)

TYPICAL USAGE				
MOBILE	SHORT DURATION	SHORT TERM STATIONARY	INTERMEDIATE TERM STATIONARY	LONG TERM STATIONARY
	✓	✓		

**GENERAL NOTES**

- Flags attached to signs where shown are REQUIRED.
- All traffic control devices illustrated are REQUIRED, except those denoted with the triangle symbol may be omitted when stated elsewhere in the plans, or for routine maintenance work, when approved by the Engineer.
- The CW3-4 "BE PREPARED TO STOP" sign may be installed after the CW20-4D "ONE LANE ROAD AHEAD" sign, but proper sign spacing shall be maintained.
- Sign spacing may be increased or an additional CW20-1D "ROAD WORK AHEAD" sign may be used if advance warning ahead of the flagger or R1-2 "YIELD" sign is less than 150 feet.
- A Shadow Vehicle with a TMA should be used anytime it can be positioned 30 to 100 feet in advance of the area of crew exposure without adversely affecting the performance or quality of the work. If workers are no longer present but road or work conditions require the traffic control to remain in place, Type 3 Barricades or other channelizing devices may be substituted for the Shadow Vehicle and TMA.
- Additional Shadow Vehicles with TMAs may be positioned off the paved surface, next to those shown in order to protect wider work spaces.

**TCP (1-2a)**

- R1-2 "YIELD" sign traffic control may be used on projects with approaches that have adequate sight distance. For projects in urban areas, work spaces should be no longer than one half city block. In rural areas on roadways with less than 2000 ADT, work spaces should be no longer than 400 feet.
- R1-2 "YIELD" sign with R1-2aP "TO ONCOMING TRAFFIC" plaque shall be placed on a support at a 7 foot minimum mounting height.

**TCP (1-2b)**

- Flaggers should use two-way radios or other methods of communication to control traffic.
- Length of work space should be based on the ability of flaggers to communicate.
- If the work space is located near a horizontal or vertical curve, the buffer distances should be increased in order to maintain adequate stopping sight distance to the flagger and a queue of stopped vehicles (see table above).
- Channelizing devices on the center-line may be omitted when a pilot car is leading traffic and approved by the Engineer.
- Flaggers should use 24" STOP/SLOW paddles to control traffic. Flags should be limited to emergency situations.

		<i>Traffic Operations Division Standard</i>	
<b>TRAFFIC CONTROL PLAN</b>			
<b>ONE-LANE TWO-WAY</b>			
<b>TRAFFIC CONTROL</b>			
<b>TCP (1-2) - 18</b>			
FILE: tcp1-2-18.dgn	DN:	CK:	DW: CK:
© TxDOT December 1985	CONT	SECT	JOB
REVISIONS	6435	38	001
4-90 4-98	DIST		COUNTY
2-94 2-12	BMT		JEFFERSON, etc
1-97 2-18			SHEET NO. 29

DATE:  
FILE:

DISCLAIMER: The use of this standard is governed by the "Texas Engineering Practice Act". No warranty of any kind is made by TxDOT for any purpose whatsoever. TxDOT assumes no responsibility for the conversion of this standard to other formats or for incorrect results or damages resulting from its use.

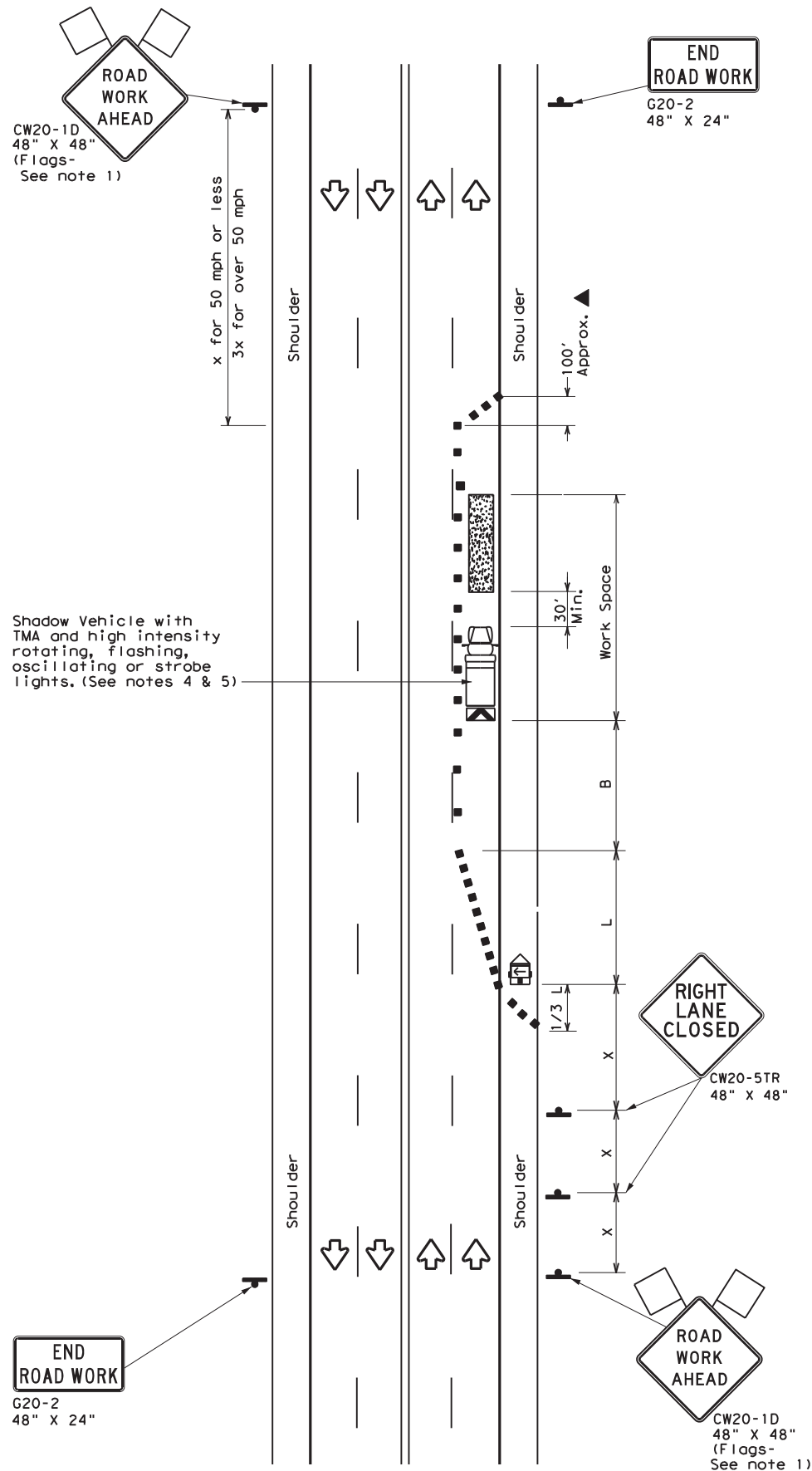

TCP (1-4a)

**ONE LANE CLOSED**

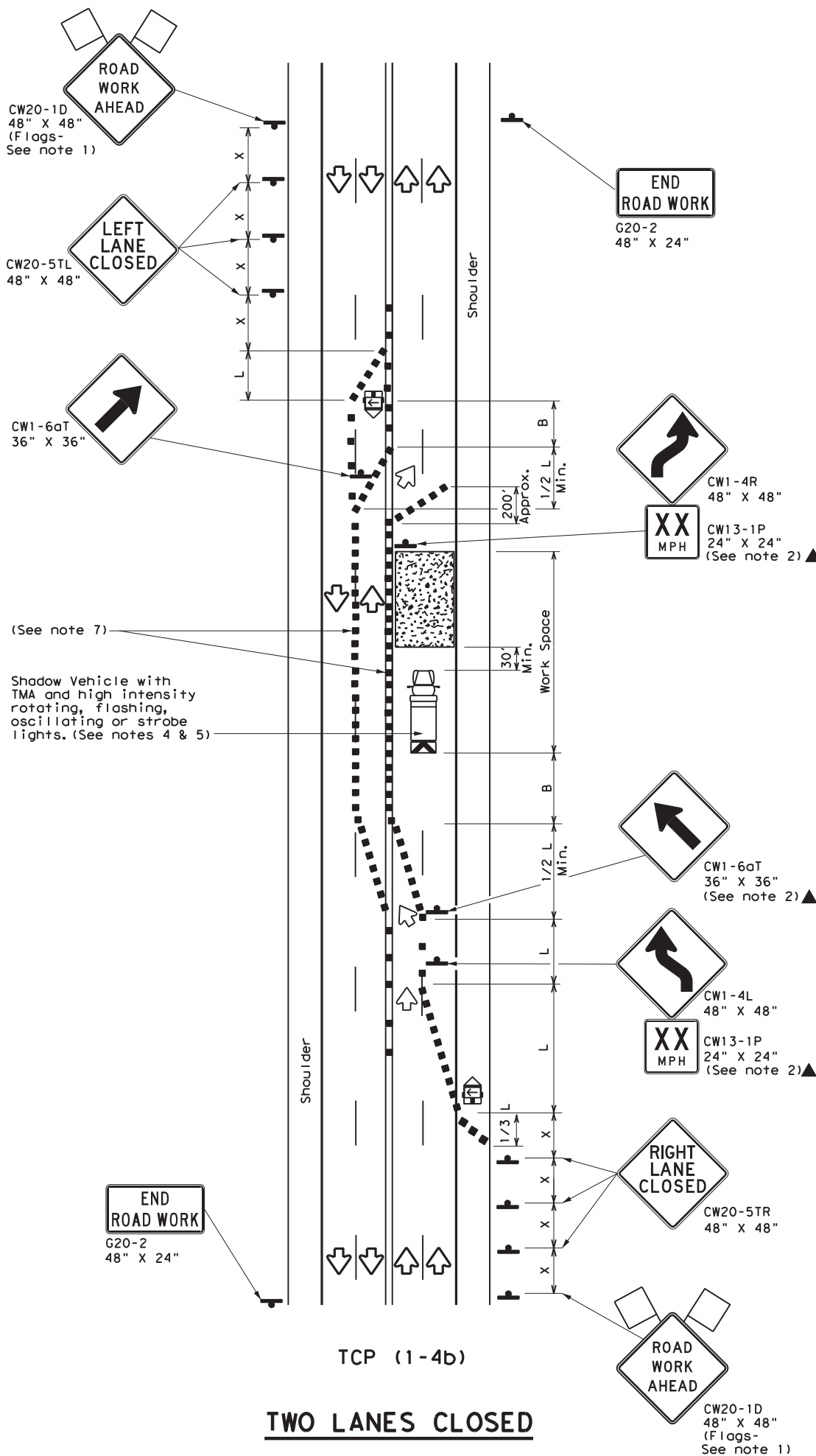

TCP (1-4b)

**TWO LANES CLOSED**

LEGEND			
	Type 3 Barricade		Channelizing Devices
	Heavy Work Vehicle		Truck Mounted Attenuator (TMA)
	Trailer Mounted Flashing Arrow Board		Portable Changeable Message Sign (PCMS)
	Sign		Traffic Flow
	Flag		Flagger

Posted Speed *	Formula	Minimum Desirable Taper Lengths **			Suggested Maximum Spacing of Channelizing Devices		Minimum Sign Spacing "X" Distance	Suggested Longitudinal Buffer Space "B"
		10' Offset	11' Offset	12' Offset	On a Taper	On a Tangent		
30	$L = \frac{WS^2}{60}$	150'	165'	180'	30'	60'	120'	90'
35		205'	225'	245'	35'	70'	160'	120'
40		265'	295'	320'	40'	80'	240'	155'
45	L = WS	450'	495'	540'	45'	90'	320'	195'
50		500'	550'	600'	50'	100'	400'	240'
55		550'	605'	660'	55'	110'	500'	295'
60		600'	660'	720'	60'	120'	600'	350'
65		650'	715'	780'	65'	130'	700'	410'
70		700'	770'	840'	70'	140'	800'	475'
75		750'	825'	900'	75'	150'	900'	540'

\* Conventional Roads Only  
 \*\* Taper lengths have been rounded off.  
 L=Length of Taper (FT) W=Width of Offset (FT) S=Posted Speed (MPH)

TYPICAL USAGE				
MOBILE	SHORT DURATION	SHORT TERM STATIONARY	INTERMEDIATE TERM STATIONARY	LONG TERM STATIONARY
	✓	✓		

**GENERAL NOTES**

- Flags attached to signs where shown are REQUIRED.
- All traffic control devices illustrated are REQUIRED, except those denoted with the triangle symbol may be omitted when stated elsewhere in the plans, or for routine maintenance work, when approved by the Engineer.
- The CW20-1D "ROAD WORK AHEAD" sign may be repeated if the visibility of the work zone is less than 1500 feet.
- A Shadow Vehicle with a TMA should be used anytime it can be positioned 30 to 100 feet in advance of the area of crew exposure without adversely affecting the performance or quality of the work. If workers are no longer present but road or work conditions require the traffic control to remain in place, Type 3 Barricades or other channelizing devices may be substituted for the Shadow Vehicle and TMA.
- Additional Shadow Vehicles with TMAs may be positioned off the paved surface, next to those shown in order to protect wider work spaces.

**TCP (1-4a)**

- If this TCP is used for a left lane closure, CW20-5TL "LEFT LANE CLOSED" signs shall be used and channelizing devices shall be placed on the centerline where needed to protect the work space from opposing traffic with the arrow panel placed in the closed lane near the end of the merging taper.

**TCP (1-4b)**

- Where traffic is directed over a yellow centerline, channelizing devices which separate two-way traffic should be spaced on tapers at 20' or 15' if posted speeds are 35 mph or slower, and for tangent sections, at 1/2S where S is the speed in mph. This tighter device spacing is intended for the areas of conflicting markings, not the entire work zone.



**TRAFFIC CONTROL PLAN  
 LANE CLOSURES ON MULTILANE  
 CONVENTIONAL ROADS**

**TCP (1-4) - 18**

FILE:	tcp1-4-18.dgn	DN:	CK:	DW:	CK:
© TxDOT	December 1985	CONT	SECT	JOB	HIGHWAY
REVISIONS		6435	38	001	IH10, etc
2-94	4-98	DIST	COUNTY	SHEET NO.	
8-95	2-12	BMT	JEFFERSON, etc	30	
1-97	2-18				

DATE:  
 FILE:

DISCLAIMER: The use of this standard is governed by the "Texas Engineering Practice Act". No warranty of any kind is made by TxDOT for any purpose whatsoever. TxDOT assumes no responsibility for the conversion of this standard to other formats or for incorrect results or damages resulting from its use.

DATE:  
FILE:

(See notes 4 & 5)

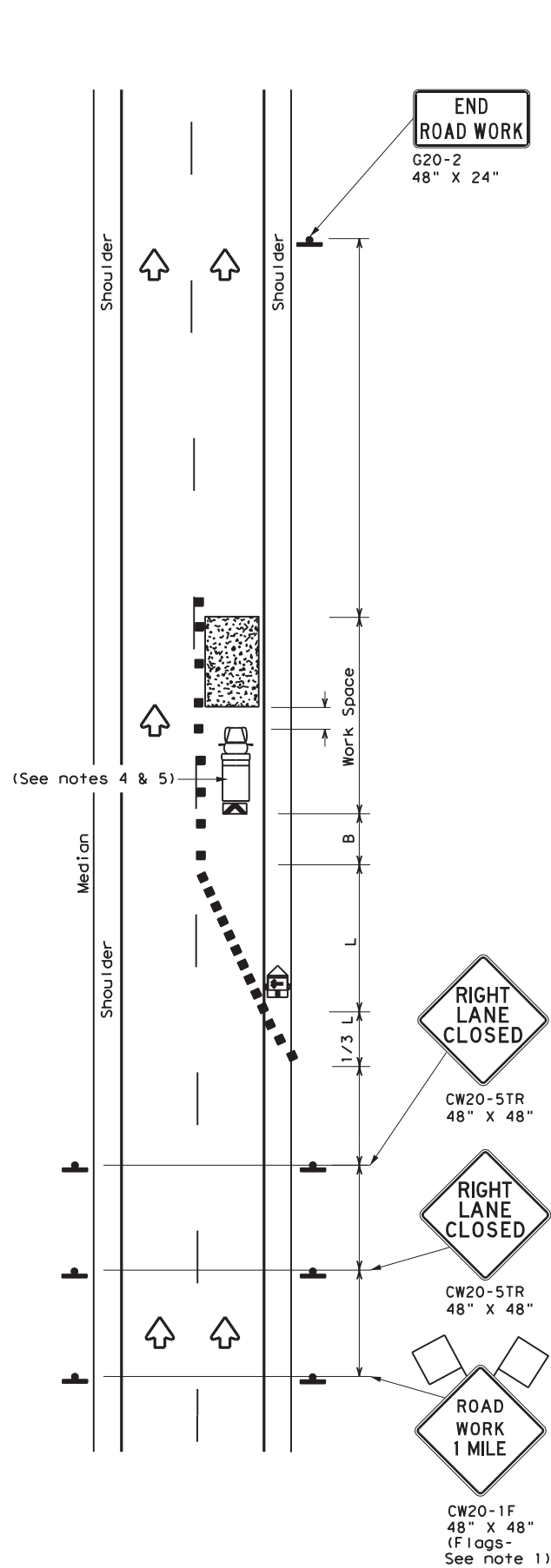

(See notes 4 & 5)

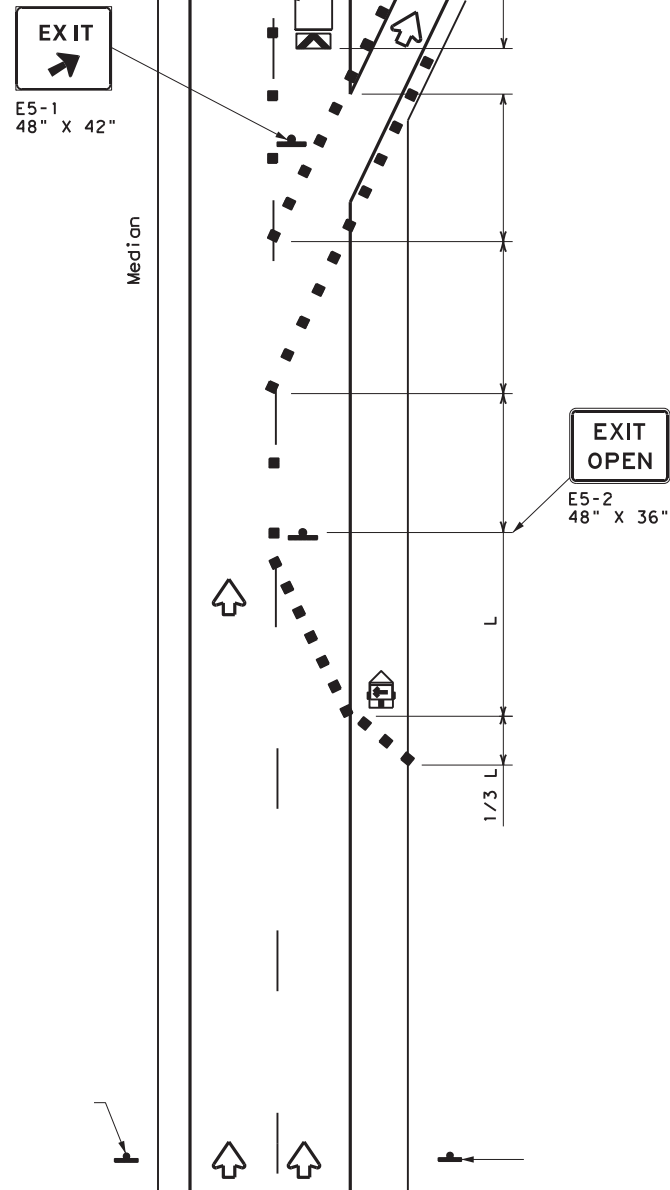

(See notes 4 & 5)

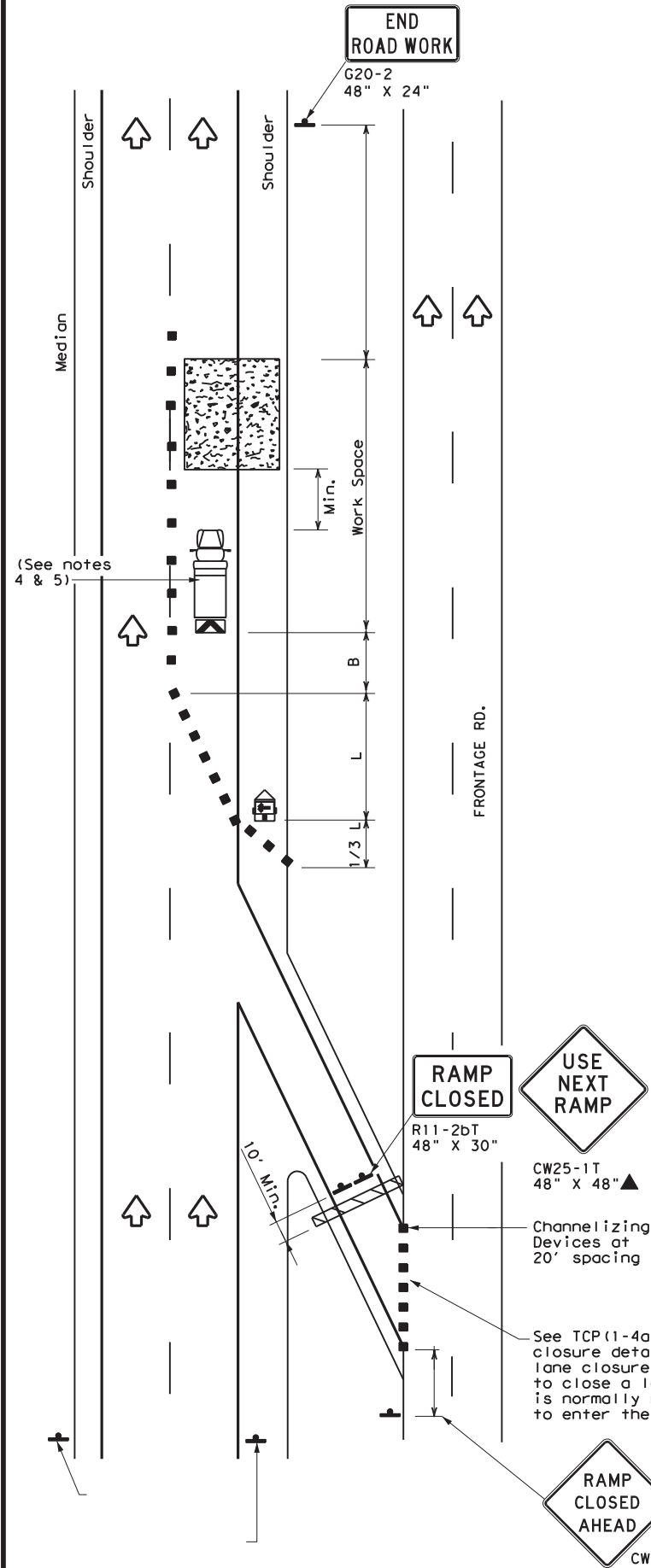

LEGEND			
	Type 3 Barricade		Channelizing Devices
	Heavy Work Vehicle		Truck Mounted Attenuator (TMA)
	Trailer Mounted Flashing Arrow Board		Portable Changeable Message Sign (PCMS)
	Sign		Traffic Flow
	Flag		Flagger

Posted Speed *	Formula	Minimum Desirable Taper Lengths **			Suggested Maximum Spacing of Channelizing Devices		Minimum Sign Spacing "X" Distance	Suggested Longitudinal Buffer Space "B"
		10' Offset	11' Offset	12' Offset	On a Taper	On a Tangent		
30	$L = \frac{WS^2}{60}$	150'	165'	180'	30'	60'	120'	90'
35		205'	225'	245'	35'	70'	160'	120'
40		265'	295'	320'	40'	80'	240'	155'
45	L = WS	450'	495'	540'	45'	90'	320'	195'
50		500'	550'	600'	50'	100'	400'	240'
55		550'	605'	660'	55'	110'	500'	295'
60		600'	660'	720'	60'	120'	600'	350'
65		650'	715'	780'	65'	130'	700'	410'
70		700'	770'	840'	70'	140'	800'	475'
75		750'	825'	900'	75'	150'	900'	540'

\* Conventional Roads Only  
 \*\* Taper lengths have been rounded off.  
 L=Length of Taper (FT) W=Width of Offset (FT) S=Posted Speed (MPH)

TYPICAL USAGE				
MOBILE	SHORT DURATION	SHORT TERM STATIONARY	INTERMEDIATE TERM STATIONARY	LONG TERM STATIONARY
		✓		

- GENERAL NOTES**
- Flags attached to signs where shown, are REQUIRED.
  - All traffic control devices illustrated are REQUIRED, except those denoted with the triangle symbol may be omitted when stated elsewhere in the plans, or for routine maintenance work, when approved by the Engineer.
  - Channelizing devices used to close lanes may be supplemented with the Chevron Alignment Sign placed on every other channelizing device. Chevrons may be attached to plastic drums as per BC Standards.
  - Shadow Vehicle with TMA and high intensity rotating, flashing, oscillating or strobe lights. A Shadow Vehicle with a TMA should be used anytime it can be positioned 30 to 100 feet in advance of the area of crew exposure without adversely affecting the performance or quality of the work. If workers are no longer present but road or work conditions require the traffic control to remain in place, Type 3 Barricades or other channelizing devices may be substituted for the Shadow Vehicle and TMA.
  - Additional Shadow Vehicles with TMAs may be positioned in each closed lane, on the shoulder or off the paved surface, next to those shown in order to protect a wider work space.

Texas Department of Transportation  
 Traffic Operations Division Standard

**TRAFFIC CONTROL PLAN  
LANE CLOSURES FOR  
DIVIDED HIGHWAYS**

**TCP (1-5) - 18**

FILE: tcp1-5-18.dgn	DN:	CK:	DW:	CK:
© TxDOT February 2012	CONT	SECT	JOB	HIGHWAY
2-18	REVISIONS	6435	38	001
	DIST	COUNTY	SHEET NO.	
	BMT	JEFFERSON, etc	31	

DISCLAIMER: The use of this standard is governed by the "Texas Engineering Practice Act". No warranty of any kind is made by TxDOT for any purpose whatsoever. TxDOT assumes no responsibility for the conversion of this standard to other formats or for incorrect results or damages resulting from its use.

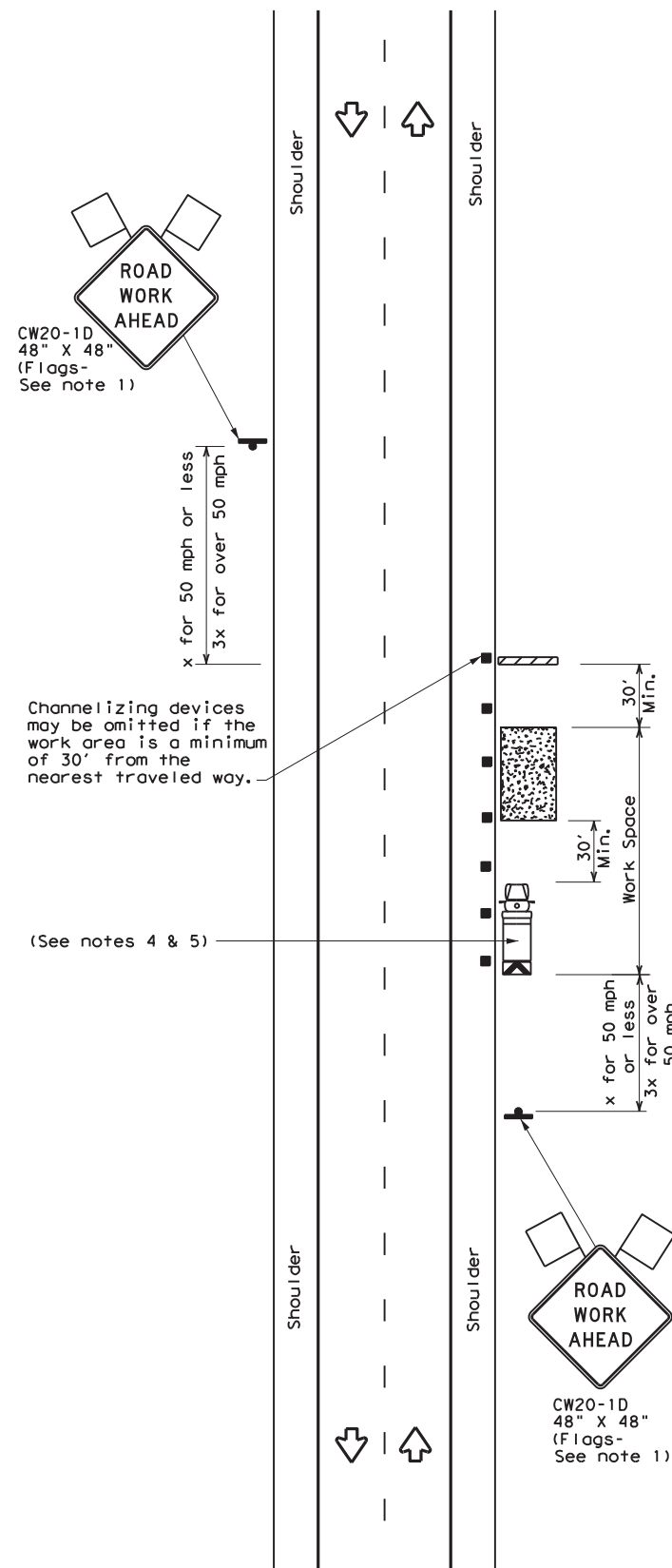

**WORK SPACE NEAR SHOULDER**  
Conventional Roads

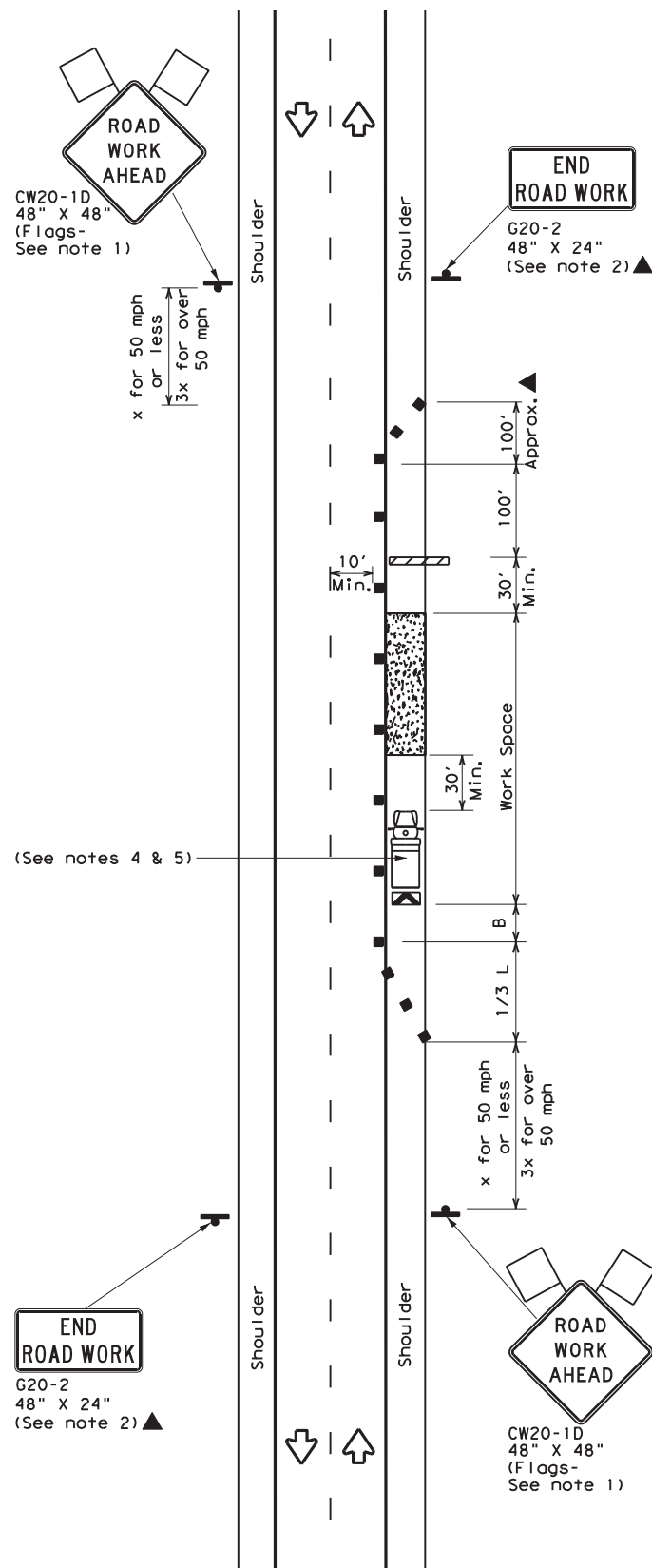

**WORK SPACE ON SHOULDER**  
Conventional Roads

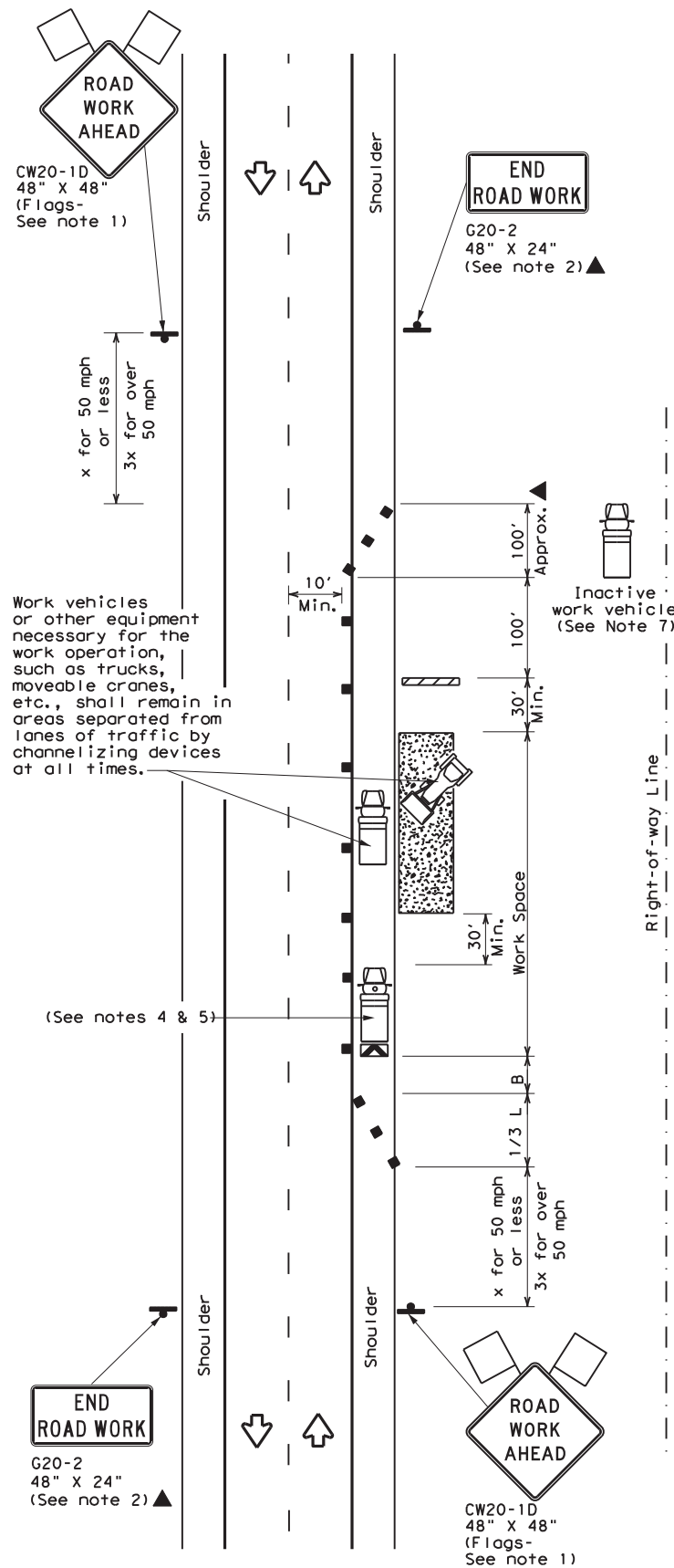

**WORK VEHICLES ON SHOULDER**  
Conventional Roads

LEGEND			
	Type 3 Barricade		Channelizing Devices
	Heavy Work Vehicle		Truck Mounted Attenuator (TMA)
	Trailer Mounted Flashing Arrow Board		Portable Changeable Message Sign (PCMS)
	Sign		Traffic Flow
	Flag		Flagger

Posted Speed *	Formula	Minimum Desirable Taper Lengths **			Suggested Maximum Spacing of Channelizing Devices		Minimum Sign Spacing "X" Distance	Suggested Longitudinal Buffer Space "B"
		10' Offset	11' Offset	12' Offset	On a Taper	On a Tangent		
30	$L = \frac{WS^2}{60}$	150'	165'	180'	30'	60'	120'	90'
35		205'	225'	245'	35'	70'	160'	120'
40		265'	295'	320'	40'	80'	240'	155'
45	L = WS	450'	495'	540'	45'	90'	320'	195'
50		500'	550'	600'	50'	100'	400'	240'
55		550'	605'	660'	55'	110'	500'	295'
60		600'	660'	720'	60'	120'	600'	350'
65		650'	715'	780'	65'	130'	700'	410'
70		700'	770'	840'	70'	140'	800'	475'
75		750'	825'	900'	75'	150'	900'	540'

\* Conventional Roads Only  
 \*\* Taper lengths have been rounded off.  
 L=Length of Taper (FT) W=Width of Offset (FT) S=Posted Speed (MPH)

TYPICAL USAGE				
MOBILE	SHORT DURATION	SHORT TERM STATIONARY	INTERMEDIATE TERM STATIONARY	LONG TERM STATIONARY
	✓	✓	✓	✓

- GENERAL NOTES**
- Flags attached to signs where shown, are REQUIRED.
  - All traffic control devices illustrated are REQUIRED, except those denoted with the triangle symbol may be omitted when stated in the plans, or for routine maintenance work, when approved by the Engineer.
  - Stockpiled material should be placed a minimum of 30 feet from nearest traveled way.
  - Shadow Vehicle with TMA and high intensity rotating, flashing, oscillating or strobe lights. A Shadow Vehicle with a TMA should be used anytime it can be positioned 30 to 100 feet in advance of the area of crew exposure without adversely affecting the performance or quality of the work. If workers are no longer present but road or work conditions require the traffic control to remain in place, Type 3 Barricades or other channelizing devices may be substituted for the Shadow Vehicle and TMA.
  - Additional Shadow Vehicles with TMAs may be positioned off the paved surface, next to those shown in order to protect a wider work space.
  - See TCP(5-1) for shoulder work on divided highways, expressways and freeways.
  - Inactive work vehicles or other equipment should be parked near the right-of-way line and not parked on the paved shoulder.
  - CW21-5 "SHOULDER WORK" signs may be used in place of CW20-1D "ROAD WORK AHEAD" signs for shoulder work on conventional roadways.



**TRAFFIC CONTROL PLAN**  
**CONVENTIONAL ROAD**  
**SHOULDER WORK**

**TCP(2-1)-18**

FILE: tcp2-1-18.dgn	DN:	CK:	DW:	CK:
© TxDOT December 1985	CONT	SECT	JOB	HIGHWAY
REVISIONS	6435	38	001	IH10, etc
2-94 4-98	DIST	COUNTY	SHEET NO.	
8-95 2-12	BMT	JEFFERSON, etc	32	
1-97 2-18				

DATE:  
FILE:



DISCLAIMER: The use of this standard is governed by the "Texas Engineering Practice Act". No warranty of any kind is made by TxDOT for any purpose whatsoever. TxDOT assumes no responsibility for the conversion of this standard to other formats or for incorrect results or damages resulting from its use.

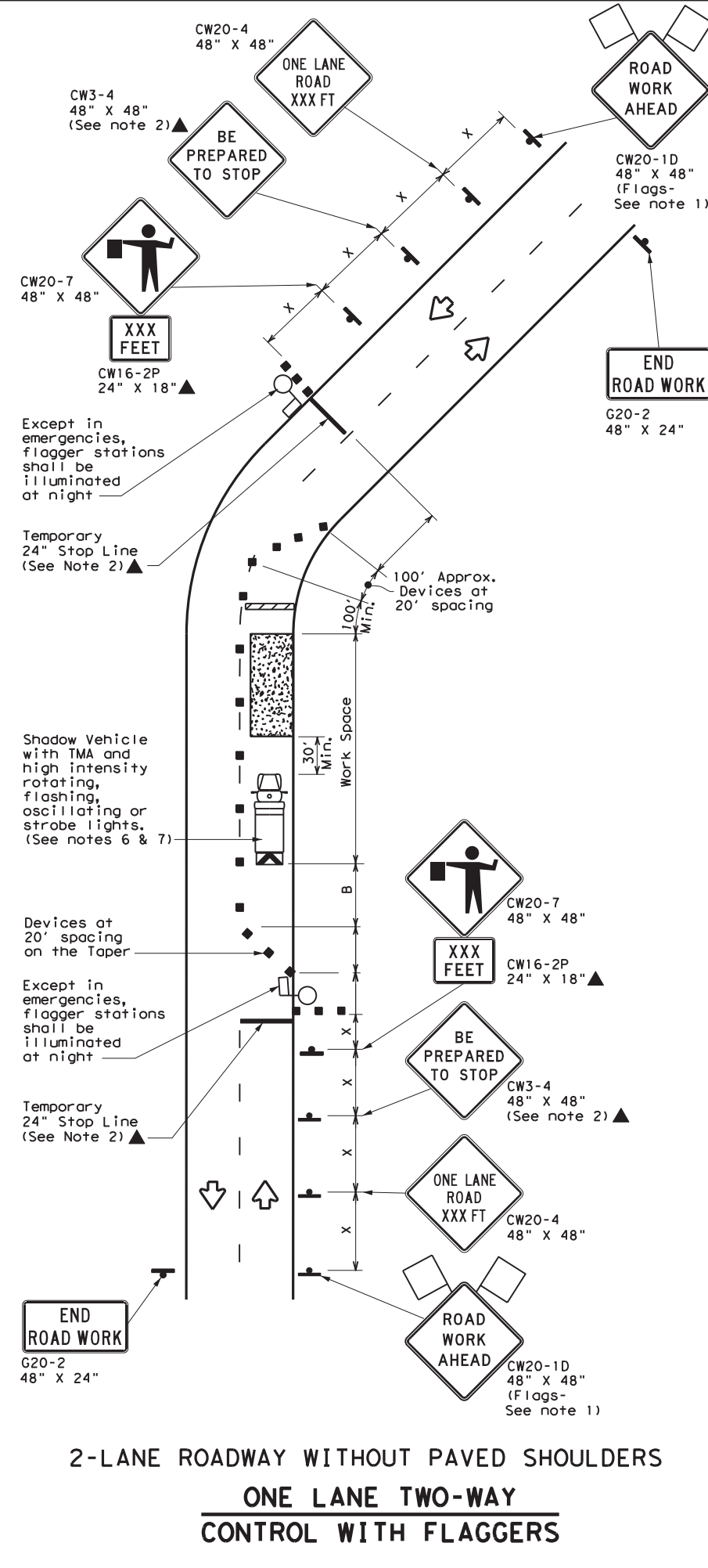
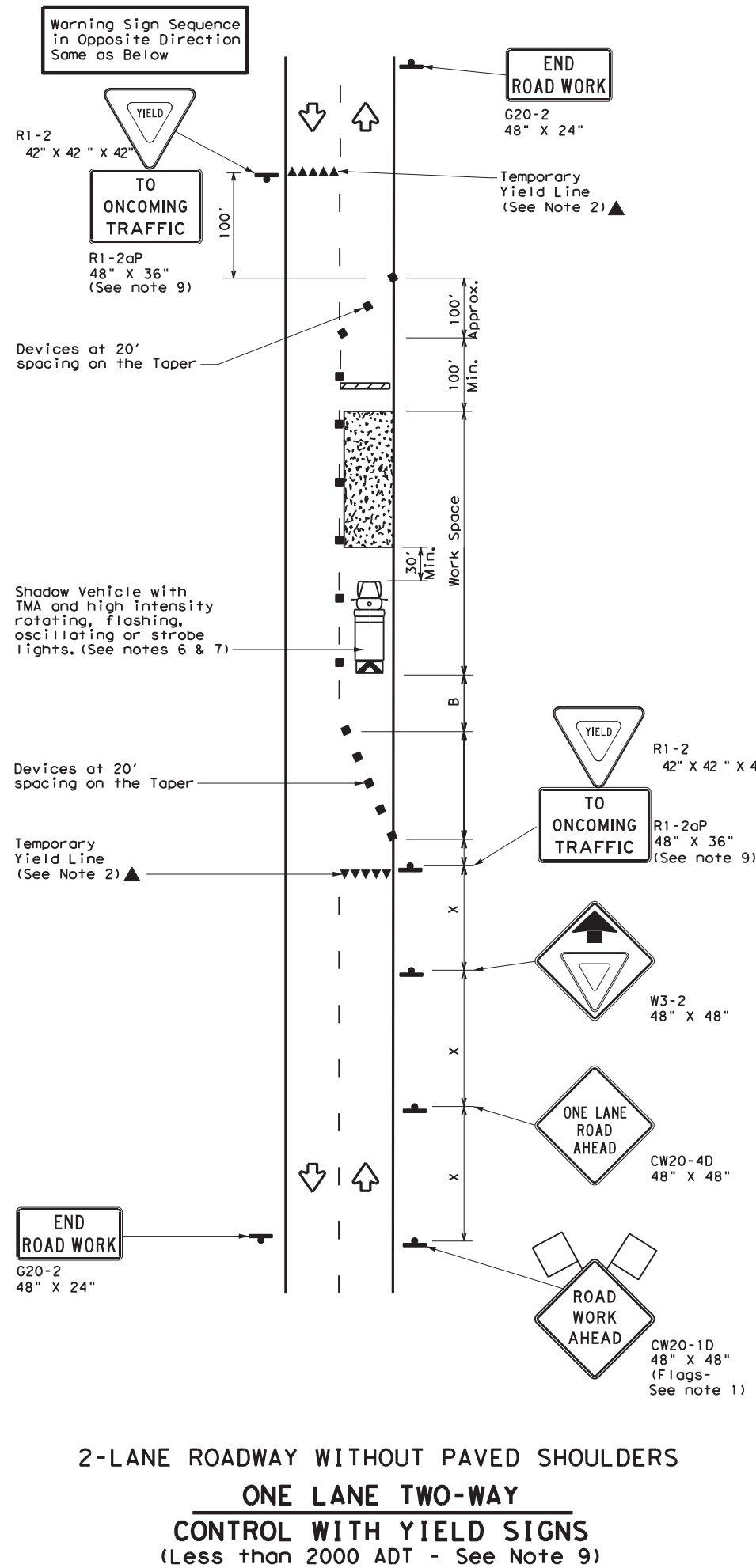

**LEGEND**

	Type 3 Barricade		Channelizing Devices
	Heavy Work Vehicle		Truck Mounted Attenuator (TMA)
	Trailer Mounted Flashing Arrow Board		Portable Changeable Message Sign (PCMS)
	Sign		Traffic Flow
	Flag		Flagger

Posted Speed *	Formula	Minimum Desirable Taper Lengths **			Suggested Maximum Spacing of Channelizing Devices		Minimum Sign Spacing "X" Distance	Suggested Longitudinal Buffer Space "B"	Stopping Sight Distance
		10' Offset	11' Offset	12' Offset	On a Taper	On a Tangent			
30	L = WS <sup>2</sup> /60	150'	165'	180'	30'	60'	120'	90'	200'
35		205'	225'	245'	35'	70'	160'	120'	250'
40		265'	295'	320'	40'	80'	240'	155'	305'
45	L = WS	450'	495'	540'	45'	90'	320'	195'	360'
50		500'	550'	600'	50'	100'	400'	240'	425'
55		550'	605'	660'	55'	110'	500'	295'	495'
60		600'	660'	720'	60'	120'	600'	350'	570'
65		650'	715'	780'	65'	130'	700'	410'	645'
70		700'	770'	840'	70'	140'	800'	475'	730'
75		750'	825'	900'	75'	150'	900'	540'	820'

\* Conventional Roads Only  
 \*\* Taper lengths have been rounded off.  
 L=Length of Taper (FT) W=Width of Offset (FT) S=Posted Speed (MPH)

**TYPICAL USAGE**

MOBILE	SHORT DURATION	SHORT TERM STATIONARY	INTERMEDIATE TERM STATIONARY	LONG TERM STATIONARY
	✓	✓	✓	

- GENERAL NOTES**
- Flags attached to signs where shown, are REQUIRED.
  - All traffic control devices illustrated are REQUIRED, except those denoted with the triangle symbol may be omitted when stated elsewhere in the plans, or for routine maintenance work, when approved by the Engineer.
  - The CW3-4 "BE PREPARED TO STOP" sign may be installed after the CW20-4 "ONE LANE ROAD XXX FT" sign, but proper sign spacing shall be maintained.
  - Flaggers should use two-way radios or other methods of communication to control traffic.
  - Length of work space should be based on the ability of flaggers to communicate.
  - A Shadow Vehicle with a TMA should be used anytime it can be positioned 30 to 100 feet in advance of the area of crew exposure without adversely affecting the performance or quality of the work. If workers are no longer present but road or work conditions require the traffic control to remain in place, Type 3 Barricades or other channelizing devices may be substituted for the Shadow Vehicle and TMA.
  - Additional Shadow Vehicles with TMAs may be positioned off the paved surface, next to those shown in order to protect a wider work space.
- TCP (2-2a)**
- The R1-2 "YIELD" sign traffic control may be used on projects with approaches that have adequate sight distance. For projects in urban areas, work space should be no longer than one half city block. In rural areas, roadways with less than 2000 ADT, work space should be no longer than 400 feet.
  - The R1-2aP "YIELD TO ONCOMING TRAFFIC" sign shall be placed on a support at a 7 foot minimum mounting height.
- TCP (2-2b)**
- Channelizing devices on the center line may be omitted when a pilot car is leading traffic and approved by the Engineer.
  - If the work space is located near a horizontal or vertical curve, the buffer distances should be increased in order to maintain stopping sight distance to the flagger and a queue of stopped vehicles. (See table above).
  - Flaggers should use 24" STOP/SLOW paddles to control traffic. Flags should be limited to emergency situations.

**Texas Department of Transportation**  
Traffic Operations Division Standard

**TRAFFIC CONTROL PLAN**  
**ONE-LANE TWO-WAY**  
**TRAFFIC CONTROL**

**TCP (2-2) - 18**

FILE: tcp2-2-18.dgn	DN:	CK:	DW:	CK:
© TxDOT December 1985	CONT	SECT	JOB	HIGHWAY
REVISIONS	6435	38	001	IH10, etc
8-95 3-03	DIST	COUNTY	SHEET NO.	
1-97 2-12	BMT	JEFFERSON, etc	33	
4-98 2-18				

162

DISCLAIMER: The use of this standard is governed by the "Texas Engineering Practice Act". No warranty of any kind is made by TxDOT for any purpose whatsoever. TxDOT assumes no responsibility for the conversion of this standard to other formats or for incorrect results or damages resulting from its use.

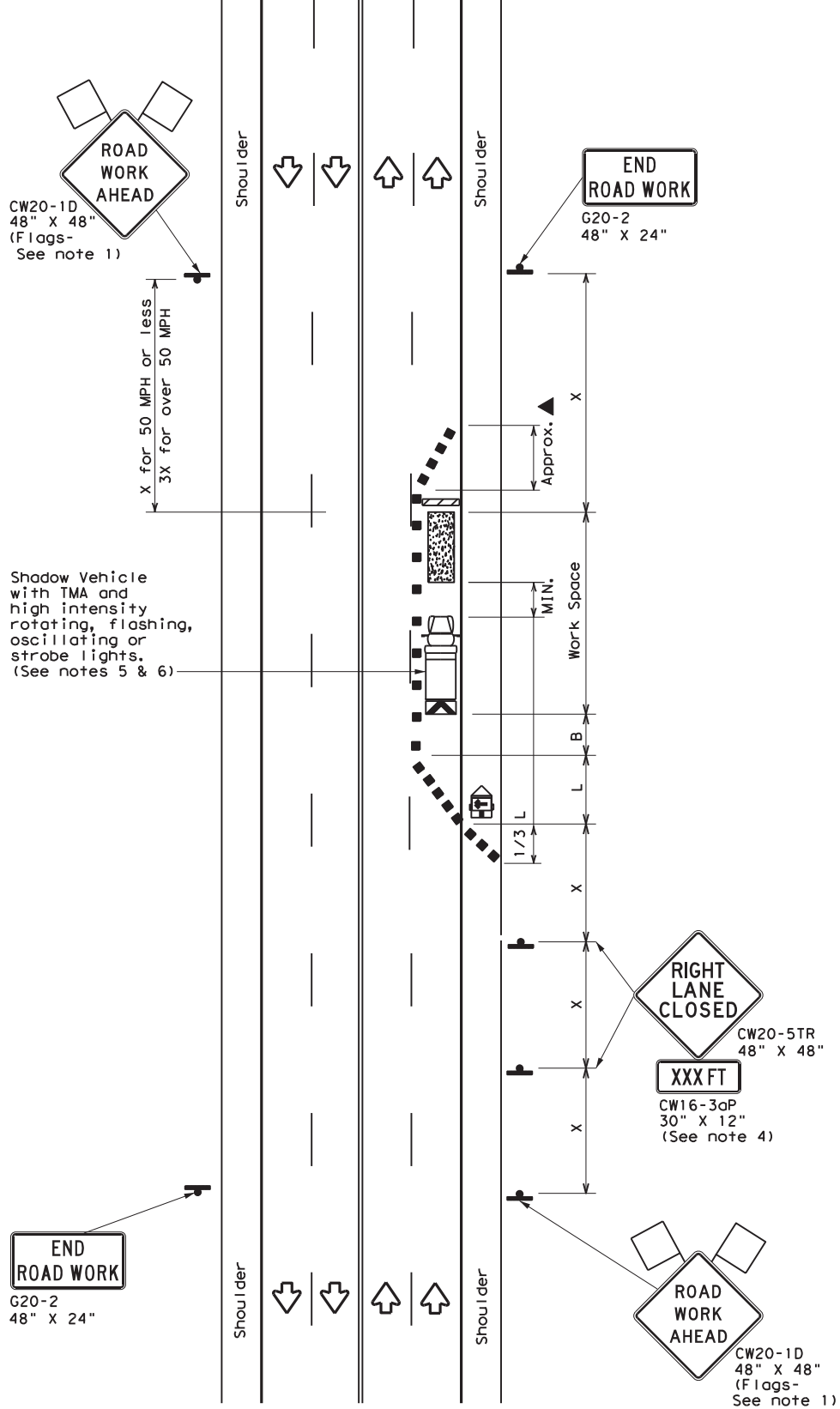

**ONE LANE CLOSED**

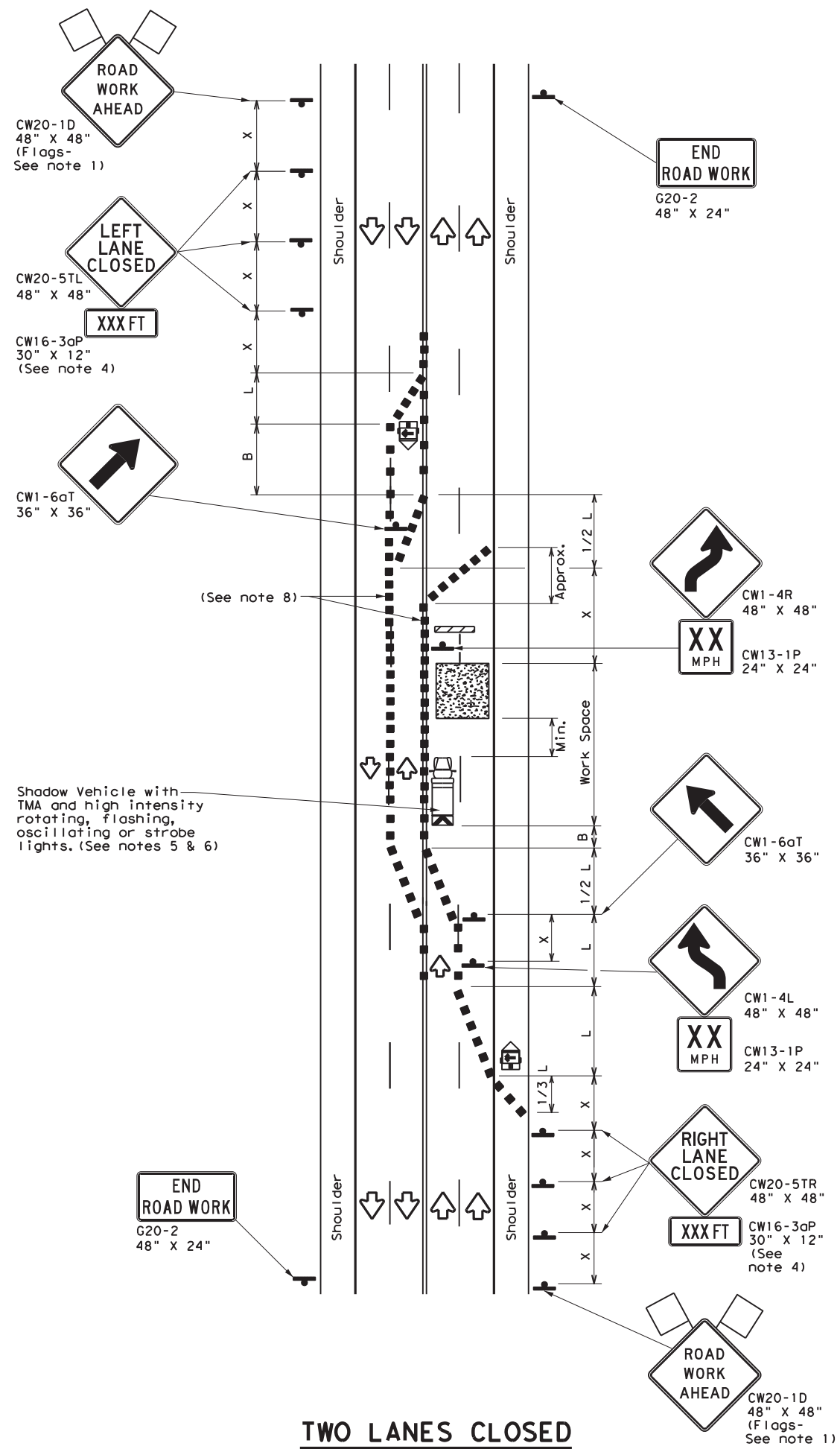

**TWO LANES CLOSED**

**LEGEND**

	Type 3 Barricade		Channelizing Devices
	Heavy Work Vehicle		Truck Mounted Attenuator (TMA)
	Trailer Mounted Flashing Arrow Board		Portable Changeable Message Sign (PCMS)
	Sign		Traffic Flow
	Flag		Flagger

Posted Speed *	Formula	Minimum Desirable Taper Lengths **			Suggested Maximum Spacing of Channelizing Devices		Minimum Sign Spacing "x" Distance	Suggested Longitudinal Buffer Space "B"
		10' Offset	11' Offset	12' Offset	On a Taper	On a Tangent		
30	L = WS <sup>2</sup> / 60	150'	165'	180'	30'	60'	120'	90'
35		205'	225'	245'	35'	70'	160'	120'
40		265'	295'	320'	40'	80'	240'	155'
45	L = WS	450'	495'	540'	45'	90'	320'	195'
50		500'	550'	600'	50'	100'	400'	240'
55		550'	605'	660'	55'	110'	500'	295'
60		600'	660'	720'	60'	120'	600'	350'
65		650'	715'	780'	65'	130'	700'	410'
70		700'	770'	840'	70'	140'	800'	475'
75		750'	825'	900'	75'	150'	900'	540'

\* Conventional Roads Only  
 \*\* Taper lengths have been rounded off.  
 L=Length of Taper (FT) W=Width of Offset (FT) S=Posted Speed (MPH)

**TYPICAL USAGE**

MOBILE	SHORT DURATION	SHORT TERM STATIONARY	INTERMEDIATE TERM STATIONARY	LONG TERM STATIONARY
		✓	✓	

**GENERAL NOTES**

- Flags attached to signs where shown, are REQUIRED.
- All traffic control devices illustrated are REQUIRED, except those denoted with the triangle symbol may be omitted when stated elsewhere in the plans, or for routine maintenance work, when approved by the Engineer.
- The downstream taper is optional. When used, it should be 100 feet minimum length per lane.
- For short term applications, when post mounted signs are not used, the distance legend may be shown on the sign face rather than on a CW16-3aP supplemental plaque.
- A Shadow Vehicle with a TMA should be used anytime it can be positioned 30 to 100 feet in advance of the area of crew exposure without adversely affecting the performance or quality of the work. If workers are no longer present but road or work conditions require the traffic control to remain in place, Type 3 Barricades or other channelizing devices may be substituted for the Shadow Vehicle and TMA.
- Additional Shadow Vehicles with TMAs may be positioned in each closed lane, on the shoulder or off the paved surface, next to those shown in order to protect a wider work space.

**TCP (2-4a)**

- If this TCP is used for a left lane closure, CW20-5TL "LEFT LANE CLOSED" signs shall be used and channelizing devices shall be placed on the centerline to protect the work space from opposing traffic with the arrow board placed in the closed lane near the end of the merging taper.

**TCP (2-4b)**

- For shorter durations where traffic is directed over a yellow centerline, channelizing devices which separate two-way traffic should be spaced on tapers at 20' or 15' if posted speeds are 35 mph or slower, and for tangent sections, at 1/2(S) where S is the speed in mph. This tighter devices spacing is intended for the area of conflicting markings, not the entire work zone.

Texas Department of Transportation  
 Traffic Operations Division Standard

**TRAFFIC CONTROL PLAN  
 LANE CLOSURES ON MULTILANE  
 CONVENTIONAL ROADS**

**TCP (2-4) - 18**

FILE: tcp2-4-18.dgn	DN:	CK:	DW:	CK:
© TxDOT December 1985	CONT	SECT	JOB	HIGHWAY
REVISIONS	6435	38	001	IH10, etc
8-95 3-03	DIST	COUNTY	SHEET NO.	
1-97 2-12	BMT	JEFFERSON, etc	34	
4-98 2-18				

DATE:  
FILE:

DISCLAIMER: The use of this standard is governed by the "Texas Engineering Practice Act". No warranty of any kind is made by TxDOT for any purpose whatsoever. TxDOT assumes no responsibility for the conversion of this standard to other formats or for incorrect results or damages resulting from its use.

DATE:  
FILE:

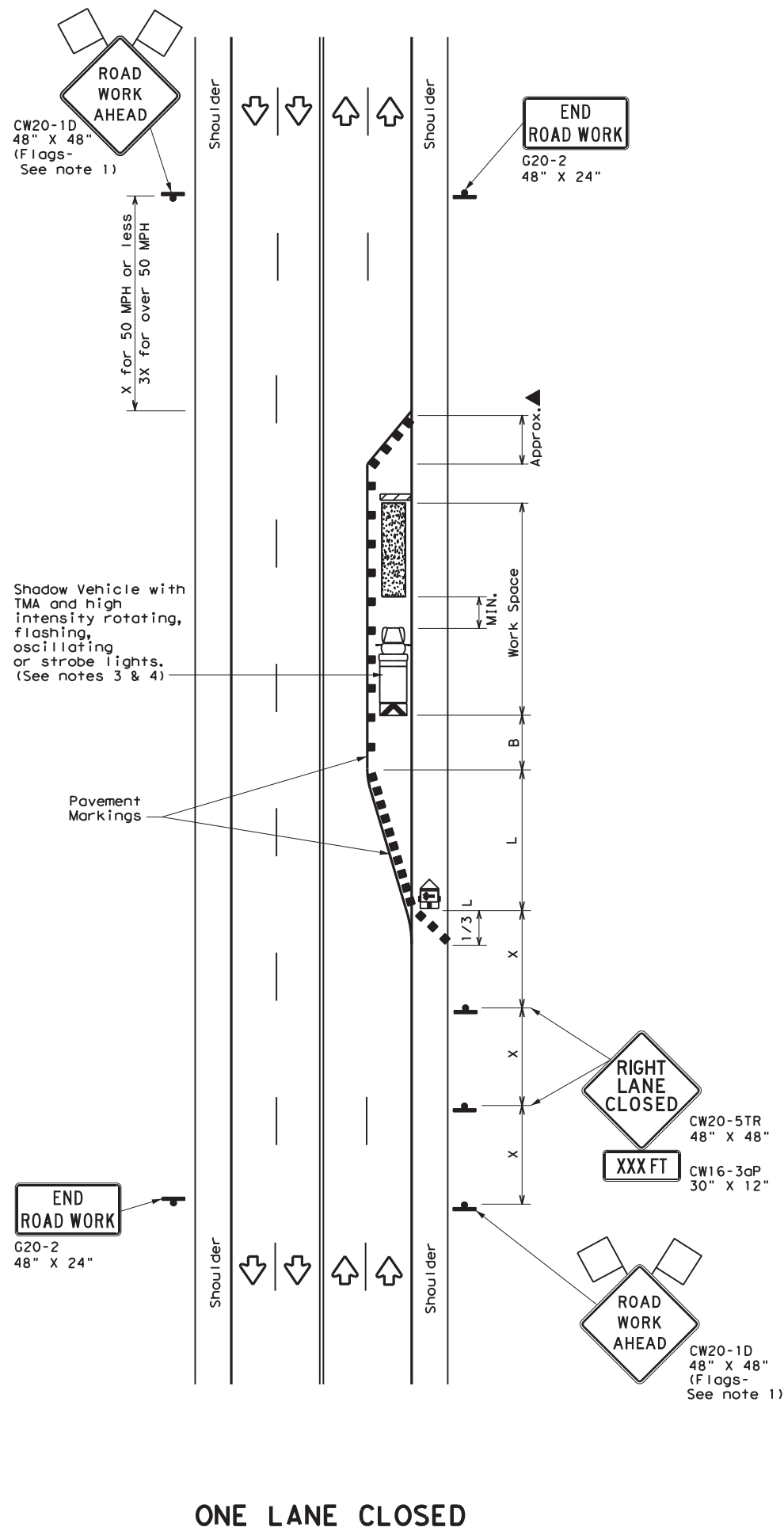

**ONE LANE CLOSED**

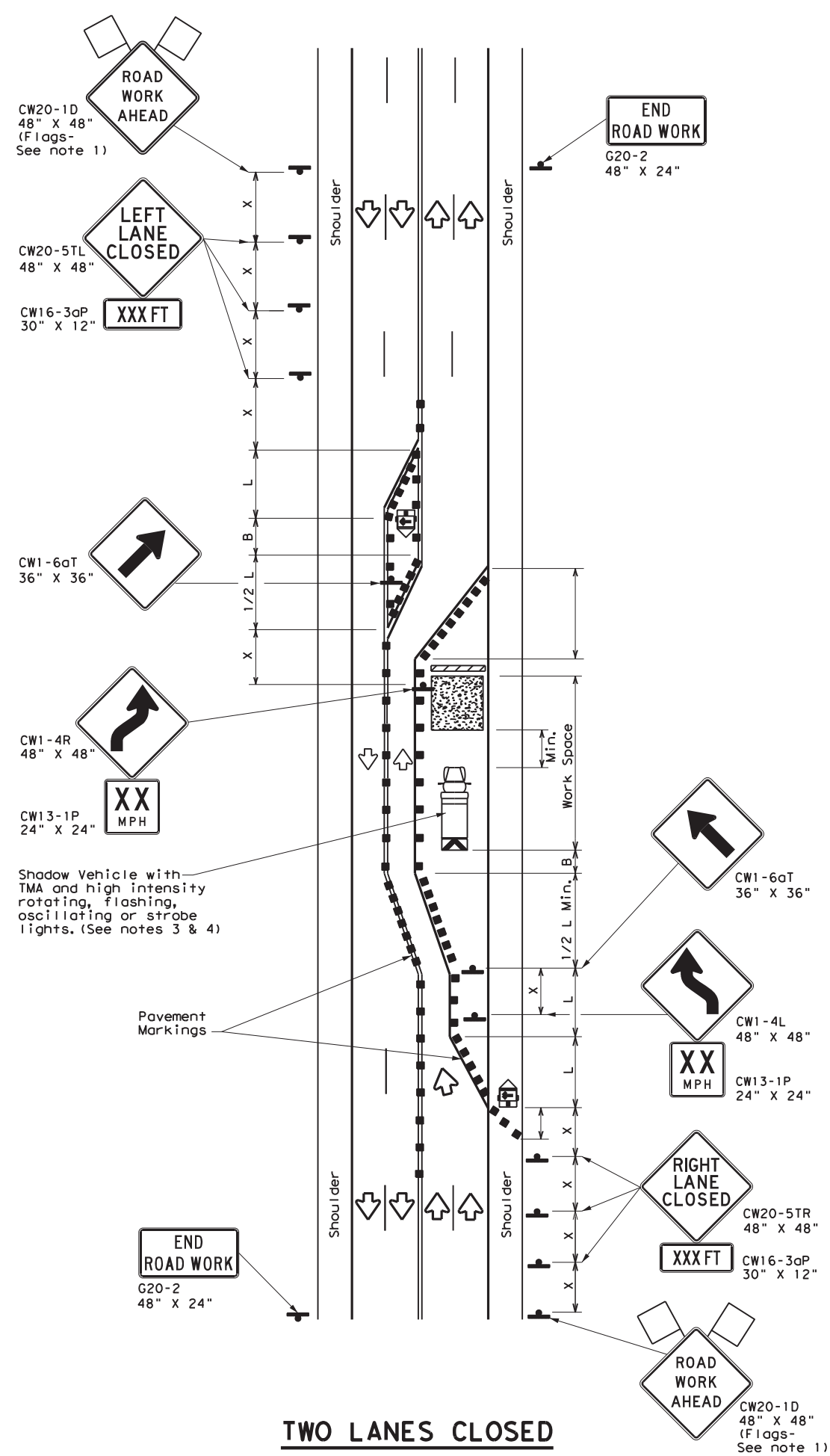

**TWO LANES CLOSED**

LEGEND			
	Type 3 Barricade		Channelizing Devices
	Heavy Work Vehicle		Truck Mounted Attenuator (TMA)
	Trailer Mounted Flashing Arrow Board		Portable Changeable Message Sign (PCMS)
	Sign		Traffic Flow
	Flag		Flagger

Posted Speed *	Formula	Minimum Desirable Taper Lengths **			Suggested Maximum Spacing of Channelizing Devices		Minimum Sign Spacing "X" Distance	Suggested Longitudinal Buffer Space "B"
		10' Offset	11' Offset	12' Offset	On a Taper	On a Tangent		
30	$L = \frac{WS^2}{60}$	150'	165'	180'	30'	60'	120'	90'
35		205'	225'	245'	35'	70'	160'	120'
40		265'	295'	320'	40'	80'	240'	155'
45	L = WS	450'	495'	540'	45'	90'	320'	195'
50		500'	550'	600'	50'	100'	400'	240'
55		550'	605'	660'	55'	110'	500'	295'
60		600'	660'	720'	60'	120'	600'	350'
65		650'	715'	780'	65'	130'	700'	410'
70		700'	770'	840'	70'	140'	800'	475'
75		750'	825'	900'	75'	150'	900'	540'

\* Conventional Roads Only  
 \*\* Taper lengths have been rounded off.  
 L=Length of Taper (FT) W=Width of Offset (FT) S=Posted Speed (MPH)

TYPICAL USAGE				
MOBILE	SHORT DURATION	SHORT TERM STATIONARY	INTERMEDIATE TERM STATIONARY	LONG TERM STATIONARY
			✓	✓

- GENERAL NOTES**
- Flags attached to signs where shown, are REQUIRED.
  - All traffic control devices illustrated are REQUIRED, except those denoted with the triangle symbol may be omitted when stated elsewhere in the plans, or for routine maintenance work, when approved by the Engineer.
  - A Shadow Vehicle with a TMA should be used anytime it can be positioned 30 to 100 feet in advance of the area of crew exposure without adversely affecting the performance or quality of the work. If workers are no longer present but road or work conditions require the traffic control to remain in place, Type 3 Barricades or other channelizing devices may be substituted for the Shadow Vehicle and TMA.
  - Additional Shadow Vehicles with TMAs may be positioned in each closed lane, on the shoulder or off the paved surface, next to those shown in order to protect a wider work space.
  - The downstream taper is optional. When used, it should be 100 feet approximately per lane, with channelizing devices spaced at 20 feet.

**TCP (2-5a)**

- If this TCP is used for a left lane closure, CW20-5TL "LEFT LANE CLOSED" signs shall be used and channelizing devices shall be placed on the centerline to protect the work space from opposing traffic, with the arrow board placed in the closed lane near the end of the merging taper.

**TCP (2-5b)**

- Conflicting pavement markings shall be removed for long-term projects.

**Texas Department of Transportation** Traffic Operations Division Standard

**TRAFFIC CONTROL PLAN**  
**LONG TERM LANE CLOSURES**  
**MULTILANE CONVENTIONAL RDS.**

**TCP (2-5) - 18**

FILE: tcp2-5-18.dgn	DN:	CK:	DW:	CK:
© TxDOT December 1985	CONT	SECT	JOB	HIGHWAY
8-95 2-12 REVISIONS	6435	38	001	IH10, etc
1-97 3-03	DIST	COUNTY	SHEET NO.	
4-98 2-18	BMT	JEFFERSON, etc	35	

1165

DISCLAIMER: The use of this standard is governed by the "Texas Engineering Practice Act". No warranty of any kind is made by TxDOT for any purpose whatsoever. TxDOT assumes no responsibility for the conversion of this standard to other formats or for incorrect results or damages resulting from its use.

DATE:  
FILE:

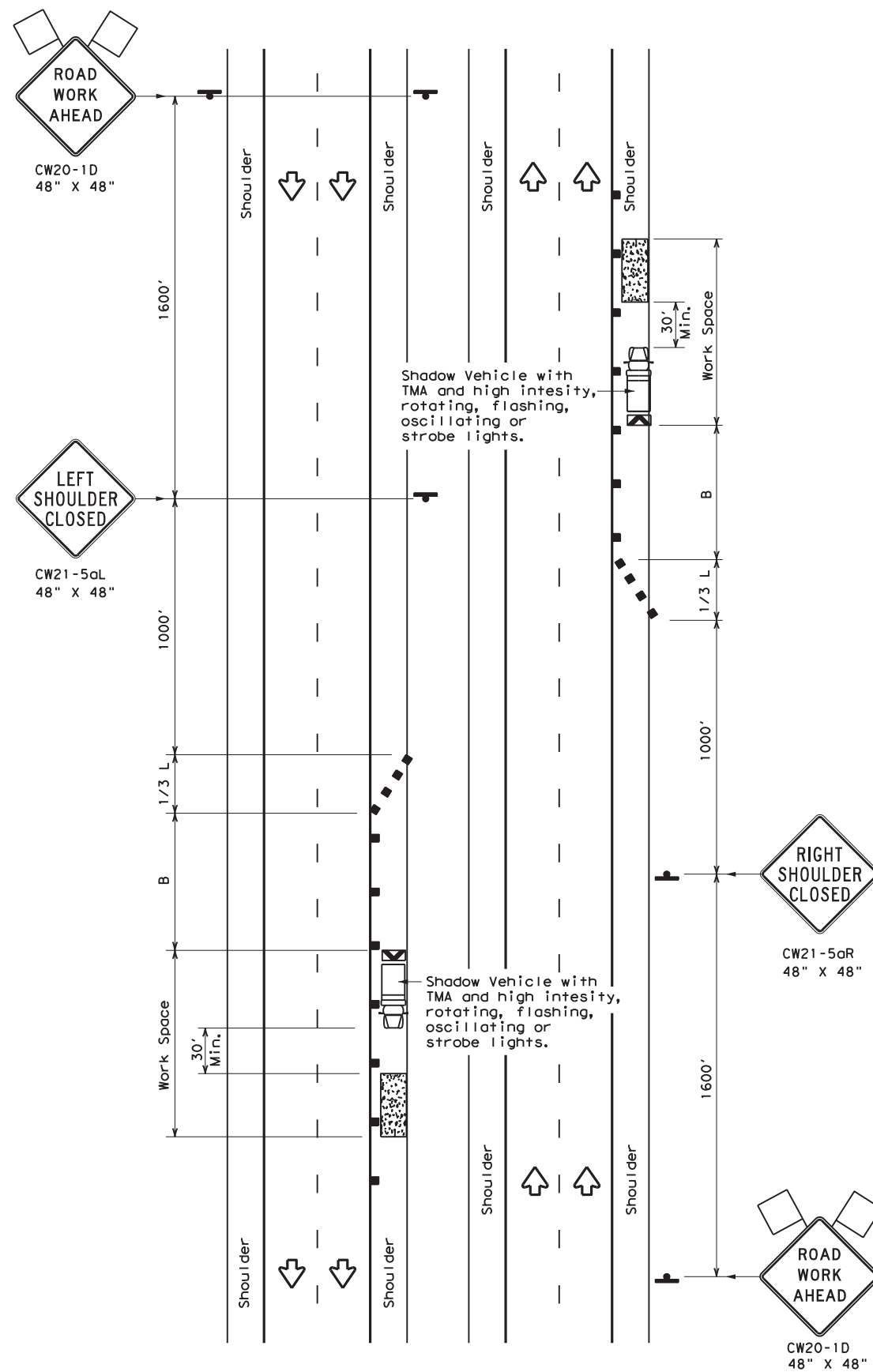

**WORK AREA ON SHOULDER**

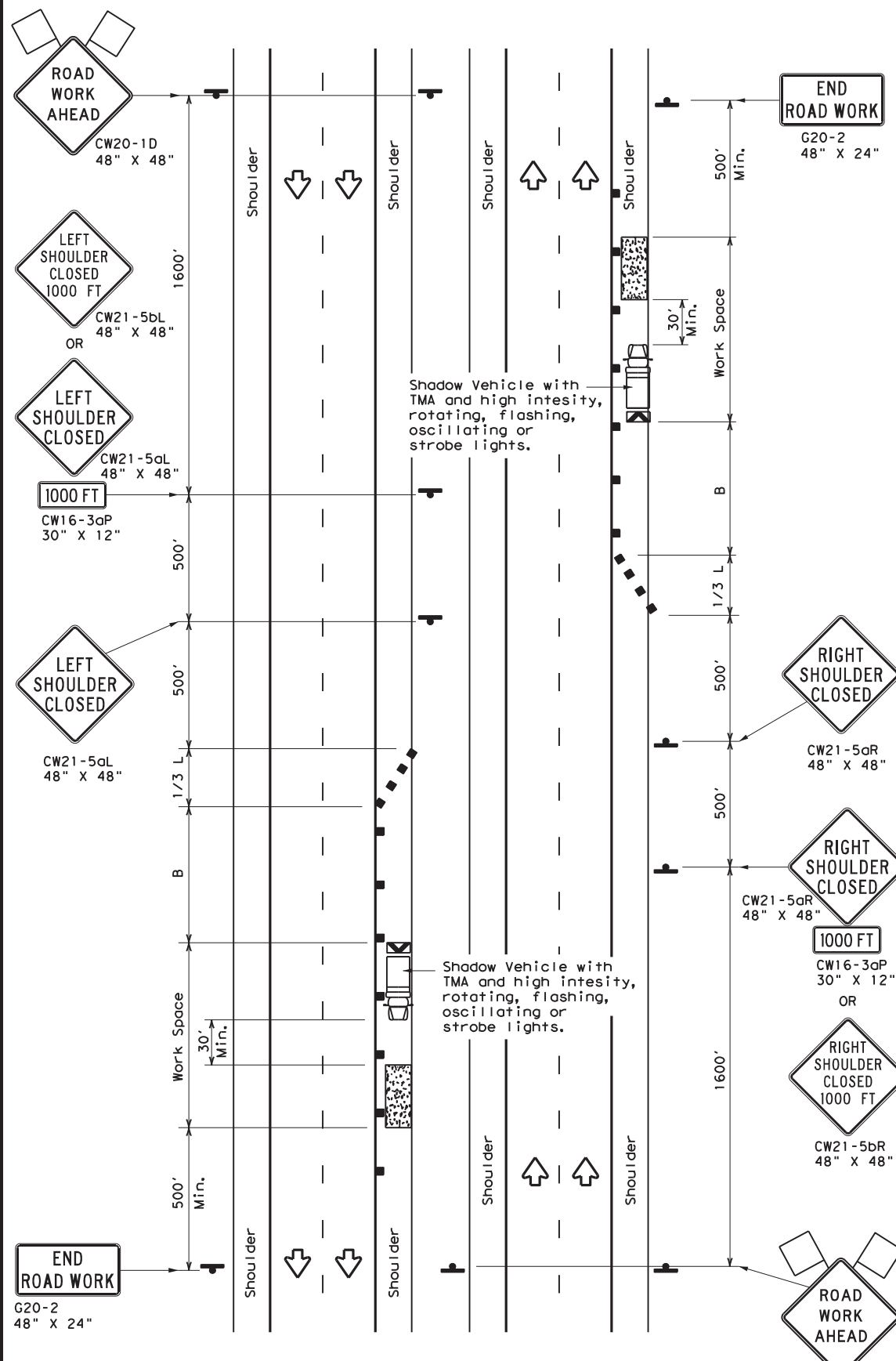

**WORK AREA ON SHOULDER**

LEGEND			
	Type 3 Barricade		Channelizing Devices
	Heavy Work Vehicle		Truck Mounted Attenuator (TMA)
	Trailer Mounted Flashing Arrow Board		Portable Changeable Message Sign (PCMS)
	Sign		Traffic Flow
	Flag		Flagger

Posted Speed *	Formula	Minimum Desirable Taper Lengths **			Suggested Maximum Spacing of Channelizing Devices		Suggested Longitudinal Buffer Space "B"
		10' Offset	11' Offset	12' Offset	On a Taper	On a Tangent	
30	L = WS <sup>2</sup> / 60	150'	165'	180'	30'	60'	90'
35		205'	225'	245'	35'	70'	120'
40		265'	295'	320'	40'	80'	155'
45	L = WS	450'	495'	540'	45'	90'	195'
50		500'	550'	600'	50'	100'	240'
55		550'	605'	660'	55'	110'	295'
60		600'	660'	720'	60'	120'	350'
65		650'	715'	780'	65'	130'	410'
70		700'	770'	840'	70'	140'	475'
75		750'	825'	900'	75'	150'	540'
80		800'	880'	960'	80'	160'	615'

\* Conventional Roads Only  
 \*\* Taper lengths have been rounded off.  
 L=Length of Taper (FT) W=Width of Offset (FT) S=Posted Speed (MPH)

TYPICAL USAGE				
MOBILE	SHORT DURATION	SHORT TERM STATIONARY	INTERMEDIATE TERM STATIONARY	LONG TERM STATIONARY
	TCP (5-1a)	TCP (5-1b)	TCP (5-1b)	

**GENERAL NOTES**

1. A Shadow Vehicle with a TMA should be used anytime it can be positioned 30' to 100' in advance of the area of crew exposure without adversely affecting the performance or quality of the work. Type 3 barricades or drums may be substituted when workers on foot are no longer present when approved by the Engineer.
2. 28" tall or taller one-piece cones will be allowed only for Short Duration or Short Term stationary operations when workers are present to maintain the devices upright and in proper location. Intermediate Term stationary work areas should use Drums, Vertical Panels or 42" tall two-piece cones.



**TRAFFIC CONTROL PLAN  
 SHOULDER WORK FOR  
 FREEWAYS / EXPRESSWAYS**

**TCP (5-1) - 18**

FILE: tcp5-1-18.dgn	DN:	CK:	DW:	CK:
© TxDOT February 2012	CONT	SECT	JOB	HIGHWAY
2-18	REVISIONS	6435	38	001
	DIST	COUNTY	SHEET NO.	
	BMT	JEFFERSON, etc	36	

DISCLAIMER: The use of this standard is governed by the "Texas Engineering Practice Act". No warranty of any kind is made by TxDOT for any purpose whatsoever. TxDOT assumes no responsibility for the conversion of this standard to other formats or for incorrect results or damages resulting from its use.

DATE: FILE:

Shadow Vehicle with TMA and high intensity rotating, flashing, oscillating or strobe lights

See note 1 and 7

See note 1 and 7

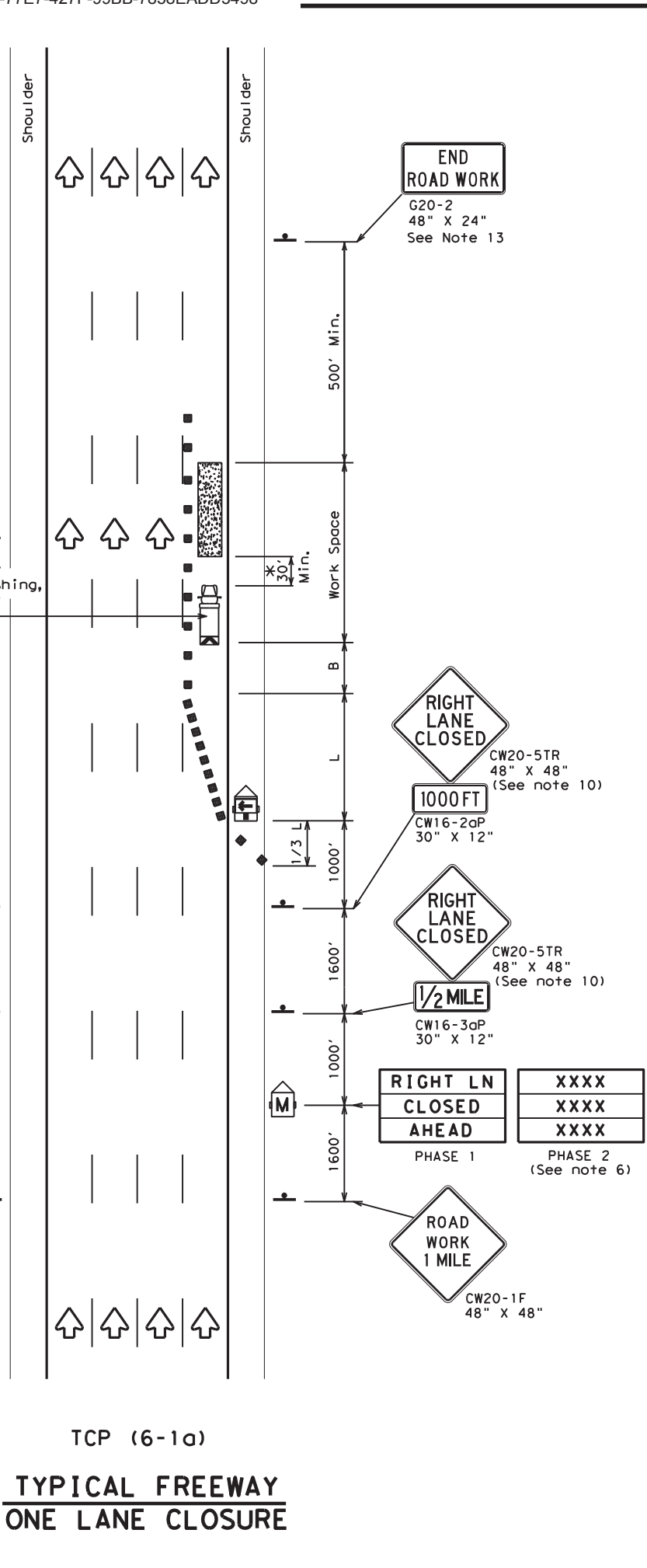

TCP (6-1a)  
**TYPICAL FREEWAY ONE LANE CLOSURE**

Shadow Vehicles with TMA and high intensity rotating, flashing, oscillating or strobe lights

See note 1 and 7

See note 1 and 7

See note 1 and 7

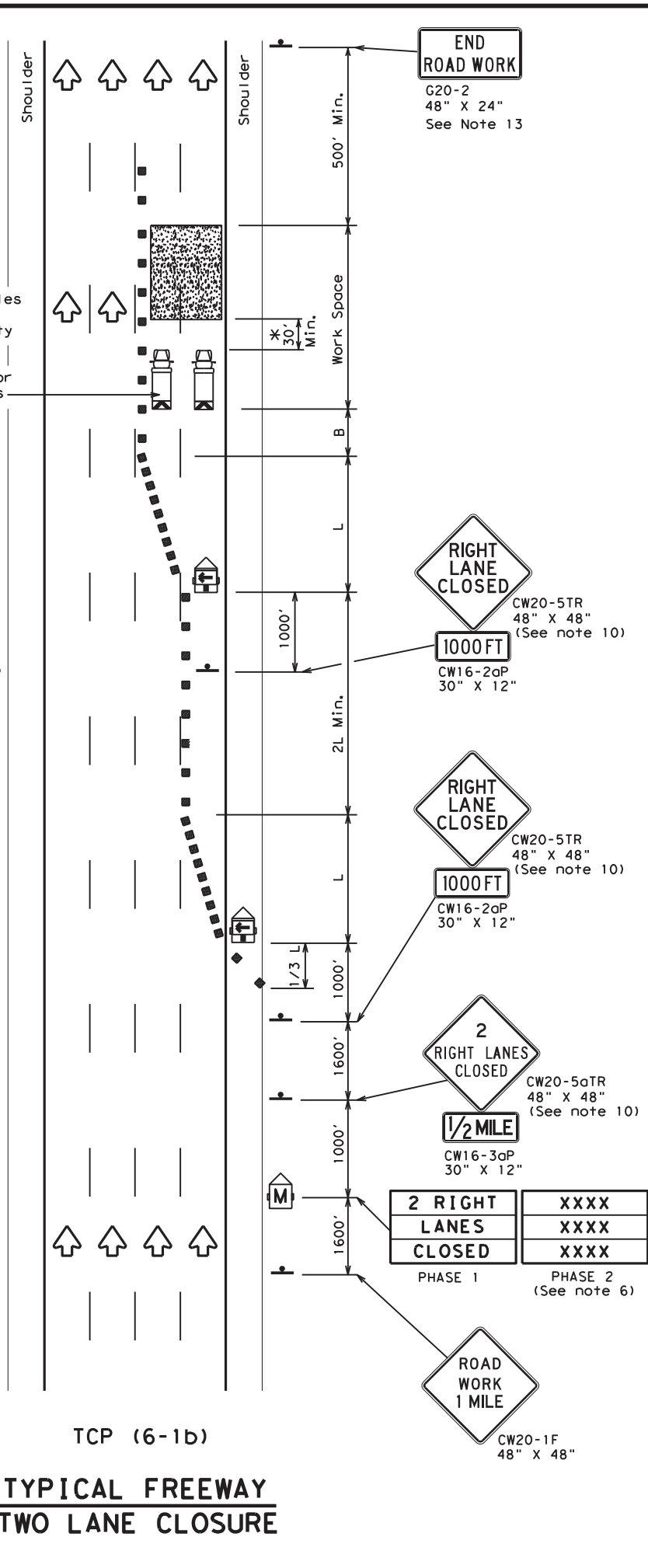

TCP (6-1b)  
**TYPICAL FREEWAY TWO LANE CLOSURE**

LEGEND			
	Type 3 Barricade		Channelizing Devices
	Heavy Work Vehicle		Truck Mounted Attenuator (TMA)
	Trailer Mounted Flashing Arrow Board		Portable Changeable Message Sign (PCMS)
	Sign		Traffic Flow
	Flag		Flagger

Posted Speed	Formula	Minimum Desirable Taper Lengths "L"			Suggested Maximum Spacing of Channelizing Devices		Suggested Longitudinal Buffer Space "B"
		10' Offset	11' Offset	12' Offset	On a Taper	On a Tangent	
45	L = WS	450'	495'	540'	45'	90'	195'
50		500'	550'	600'	50'	100'	240'
55		550'	605'	660'	55'	110'	295'
60		600'	660'	720'	60'	120'	350'
65		650'	715'	780'	65'	130'	410'
70		700'	770'	840'	70'	140'	475'
75		750'	825'	900'	75'	150'	540'
80	800'	880'	960'	80'	160'	615'	

\*\* Taper lengths have been rounded off.  
L=Length of Taper (FT) W=Width of Offset (FT) S=Posted Speed (MPH)

TYPICAL USAGE				
MOBILE	SHORT DURATION	SHORT TERM STATIONARY	INTERMEDIATE TERM STATIONARY	LONG TERM STATIONARY
	✓	✓	✓	

**GENERAL NOTES**

- All traffic control devices illustrated are REQUIRED. Devices denoted with the triangle symbol may be omitted when stated elsewhere in the plans.
- Drums or 42" cones are the typical channelizing devices. For Intermediate Term Stationary work, drums shall be used on tapers with drums or 42" cones used on tangent sections. Other channelizing devices may be used as directed by the Engineer.
- All construction signs and barricades placed during any phase of work shall remain in place until removal is approved by the Engineer.
- The Engineer may direct the Contractor to furnish additional signs and barricades as required to maintain traffic flow, detours and motorist safety during construction.
- Static message boards or changeable message signs stating the date and duration of ramp or freeway lane closures shall be placed a minimum of seven (7) calendar days in advance of the actual closure.
- Phase 2 of the PCMS message should include appropriate information formatted as shown on BC(6), such as "MERGE LEFT," recommended advisory speed, delay information, or other specific warnings.
- Duplicate construction warning signs should be erected on the medians side of freeways where median width will permit and traffic volume justifies the signing.
- The number of closed lanes may be increased provided the spacing of traffic control devices, taper lengths and tangent lengths meet the requirements of the TMUTCD.
- Warning signs for intermediate term stationary work should be mounted at 7' to the bottom of the sign.
- Warning signs shown shall be appropriately altered for left lane closures. When signs are mounted at 1' height for short term stationary or short duration work, sign versions shown in the SHSD for Texas with distances on the sign face rather than mounted on a plaque below the sign may be used.
- When possible, PCMS units should be located in advance of the last available exit ramp prior to the lane closure to allow motorists an alternate route. They may also be relocated to improve advance warning in case of unanticipated queuing or congestion.
- For Intermediate Term Stationary work at night, floodlights should be used to illuminate the work area and equipment crossings. Floodlights shall not produce a disabling glare condition for road users or workers.
- The END ROAD WORK (G20-2) sign may be omitted when it conflicts with G20-2 signs already in place on the project.

\* A shadow vehicle equipped with a Truck Mounted Attenuator is typically required. A shadow vehicle equipped with a TMA shall be used if it can be positioned 30' to 100' in advance of the area of crew exposure without adversely affecting the work performance.



**TRAFFIC CONTROL PLAN  
FREEWAY LANE CLOSURES**

**TCP (6-1) - 12**

FILE:	tcp6-1.dgn	DN:	TxDOT	CK:	TxDOT	DW:	TxDOT	CK:	TxDOT
© TxDOT	February 1998	CONT	SECT	JOB	HIGHWAY				
8-12	REVISIONS	6435	38	001	IH10, etc				
	DIST	COUNTY		SHEET NO.					
	BMT	JEFFERSON, etc		37					

DISCLAIMER: The use of this standard is governed by the "Texas Engineering Practice Act". No warranty of any kind is made by TxDOT for any purpose whatsoever. TxDOT assumes no responsibility for the conversion of this standard to other formats or for incorrect results or damages resulting from its use.

Shadow Vehicle with TMA and high intensity rotating, flashing, oscillating or strobe lights

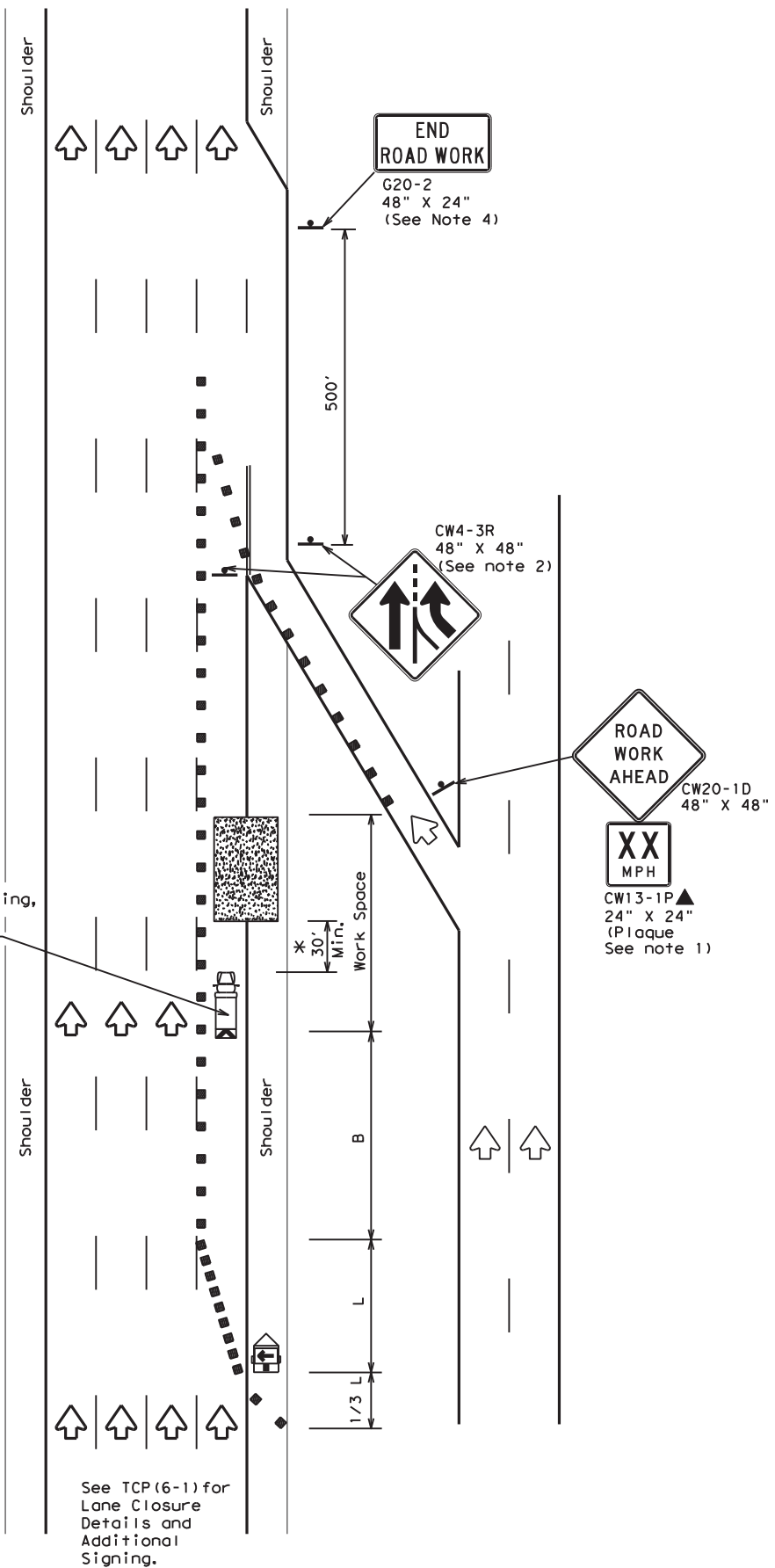

TCP (6-2a)  
**ENTRANCE RAMP OPEN**  
**WORK WITHIN 500' OF RAMP**

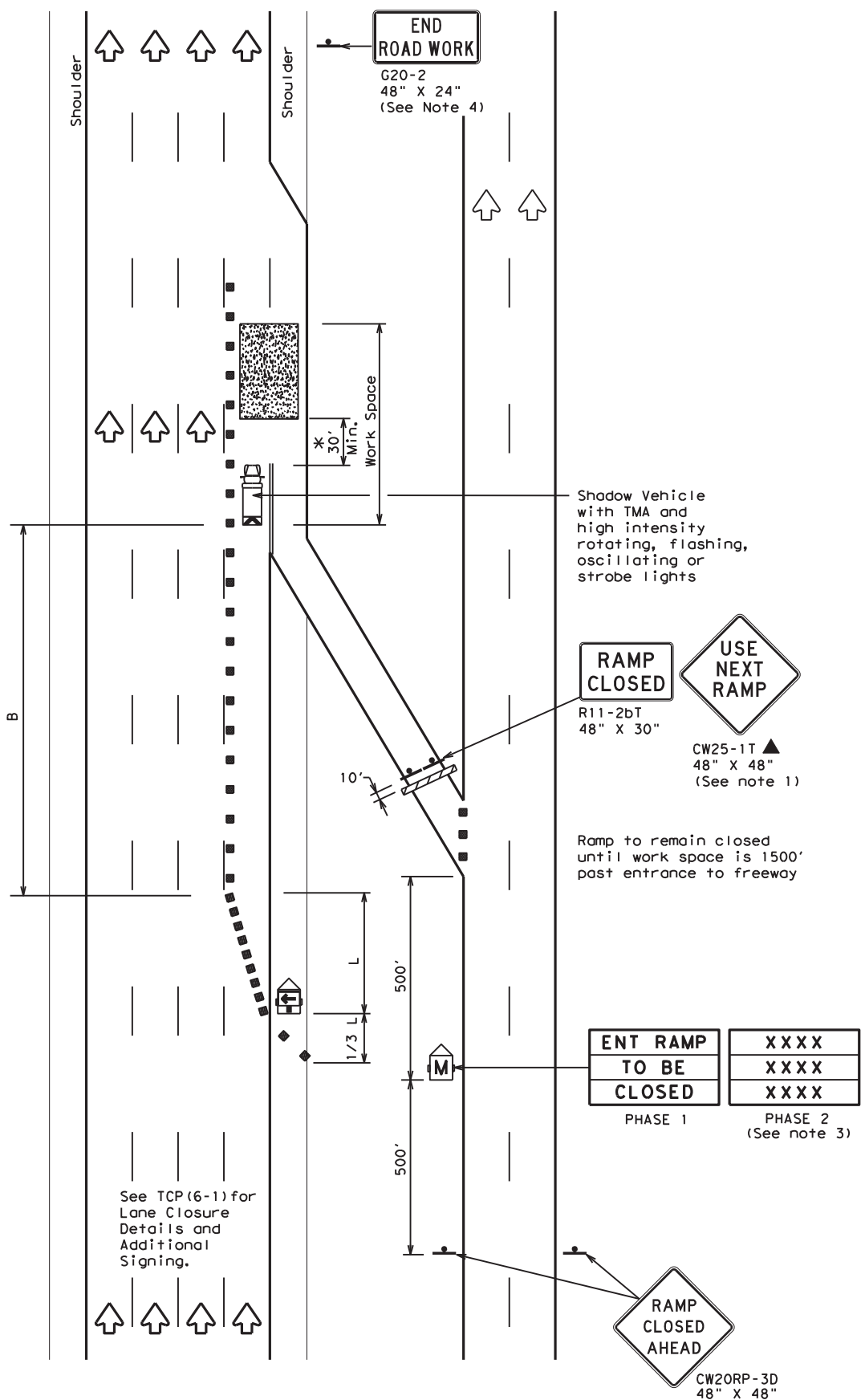

TCP (6-2b)  
**ENTRANCE RAMP CLOSED**

LEGEND			
	Type 3 Barricade		Channelizing Devices
	Heavy Work Vehicle		Truck Mounted Attenuator (TMA)
	Trailer Mounted Flashing Arrow Board		Portable Changeable Message Sign (PCMS)
	Sign		Traffic Flow
	Flag		Flagger

Posted Speed	Formula	Minimum Desirable Taper Lengths "L"			Suggested Maximum Spacing of Channelizing Devices		Suggested Longitudinal Buffer Space "B"
		10' Offset	11' Offset	12' Offset	On a Taper	On a Tangent	
45	L = WS	450'	495'	540'	45'	90'	195'
50		500'	550'	600'	50'	100'	240'
55		550'	605'	660'	55'	110'	295'
60		600'	660'	720'	60'	120'	350'
65		650'	715'	780'	65'	130'	410'
70		700'	770'	840'	70'	140'	475'
75		750'	825'	900'	75'	150'	540'
80		800'	880'	960'	80'	160'	615'

\*\* Taper lengths have been rounded off.  
L=Length of Taper (FT) W=Width of Offset(FT) S=Posted Speed(MPH)

TYPICAL USAGE				
MOBILE	SHORT DURATION	SHORT TERM STATIONARY	INTERMEDIATE TERM STATIONARY	LONG TERM STATIONARY
	✓	✓	✓	

**GENERAL NOTES**

- All traffic control devices illustrated are REQUIRED. Devices denoted with the triangle symbol may be omitted when stated elsewhere in the plans.
- ADDED LANE Symbol (CW4-3) sign may be omitted when sign between ramp and mainline can be seen from both roadways.
- See "Advance Notice List" on BC(6) for recommended date and time formatting options for PCMS Phase 2 message.
- The END ROAD WORK (G20-2) sign may be omitted when it conflicts with G20-2 signs already in place on the project.

\*A shadow vehicle equipped with a Truck Mounted Attenuator is typically required. A shadow vehicle equipped with a TMA shall be used if it can be positioned 30' to 100' in advance of the area of crew exposure without adversely affecting the work performance.

Additional requirements for lane closures and advance signing shall be as shown on TCP (6-1) or as directed by the Engineer.



**TRAFFIC CONTROL PLAN**  
**WORK AREA NEAR RAMP**

**TCP (6-2) - 12**

FILE:	tcp6-2.dgn	DN:	TxDOT	CK:	TxDOT	DW:	TxDOT	CR:	TxDOT
©TxDOT	February 1994	CONT	SECT	JOB	HIGHWAY				
REVISIONS		6435	38	001	IH10, etc				
1-97	8-98			DIST	COUNTY	SHEET NO.			
4-98	8-12	BMT	JEFFERSON, etc			38			

DATE:  
FILE:

DISCLAIMER: The use of this standard is governed by the "Texas Engineering Practice Act". No warranty of any kind is made by TxDOT for any purpose whatsoever. TxDOT assumes no responsibility for the conversion of this standard to other formats or for incorrect results or damages resulting from its use.

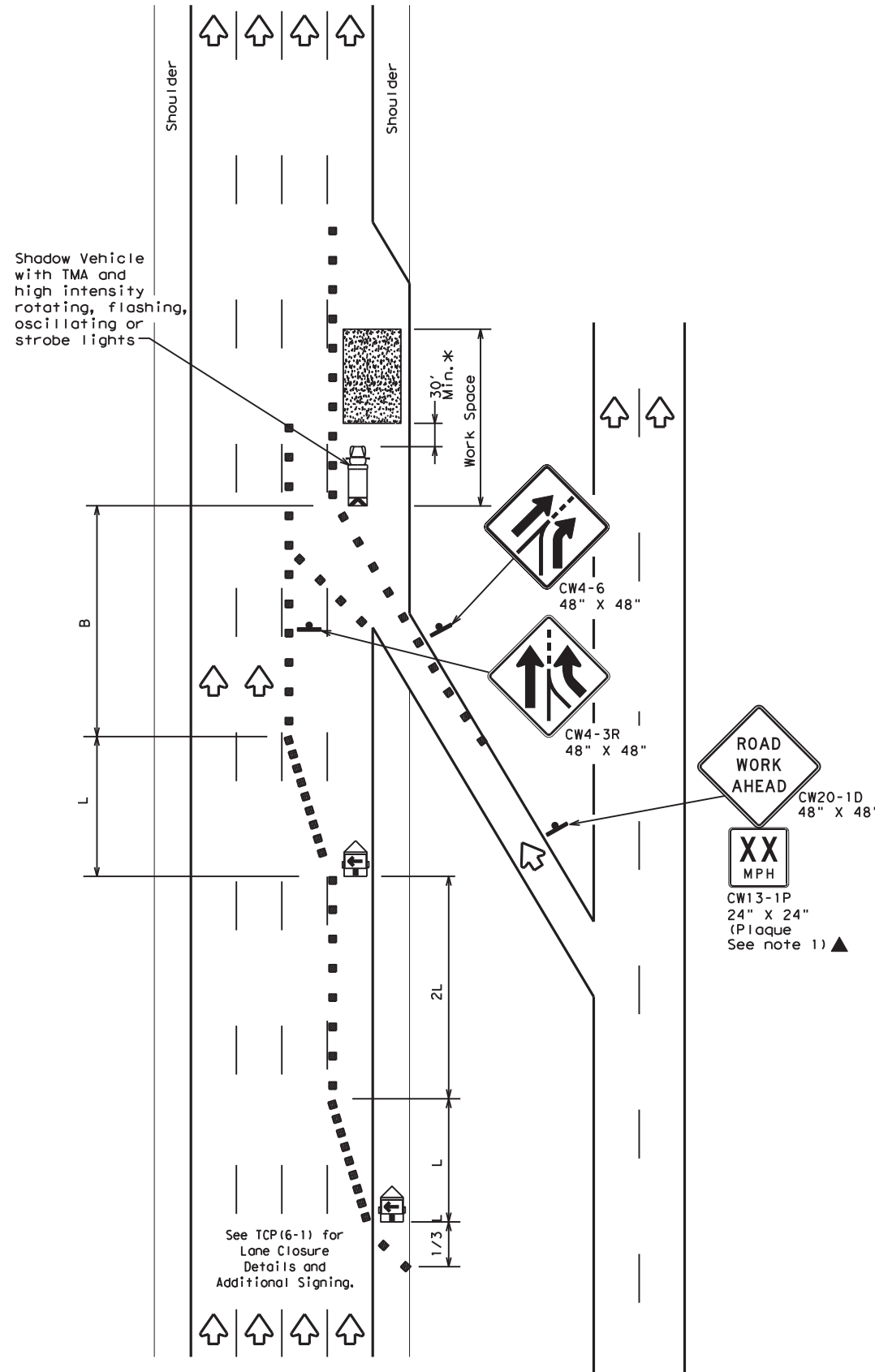

TCP (6-3a)  
ENTRANCE RAMP OPEN

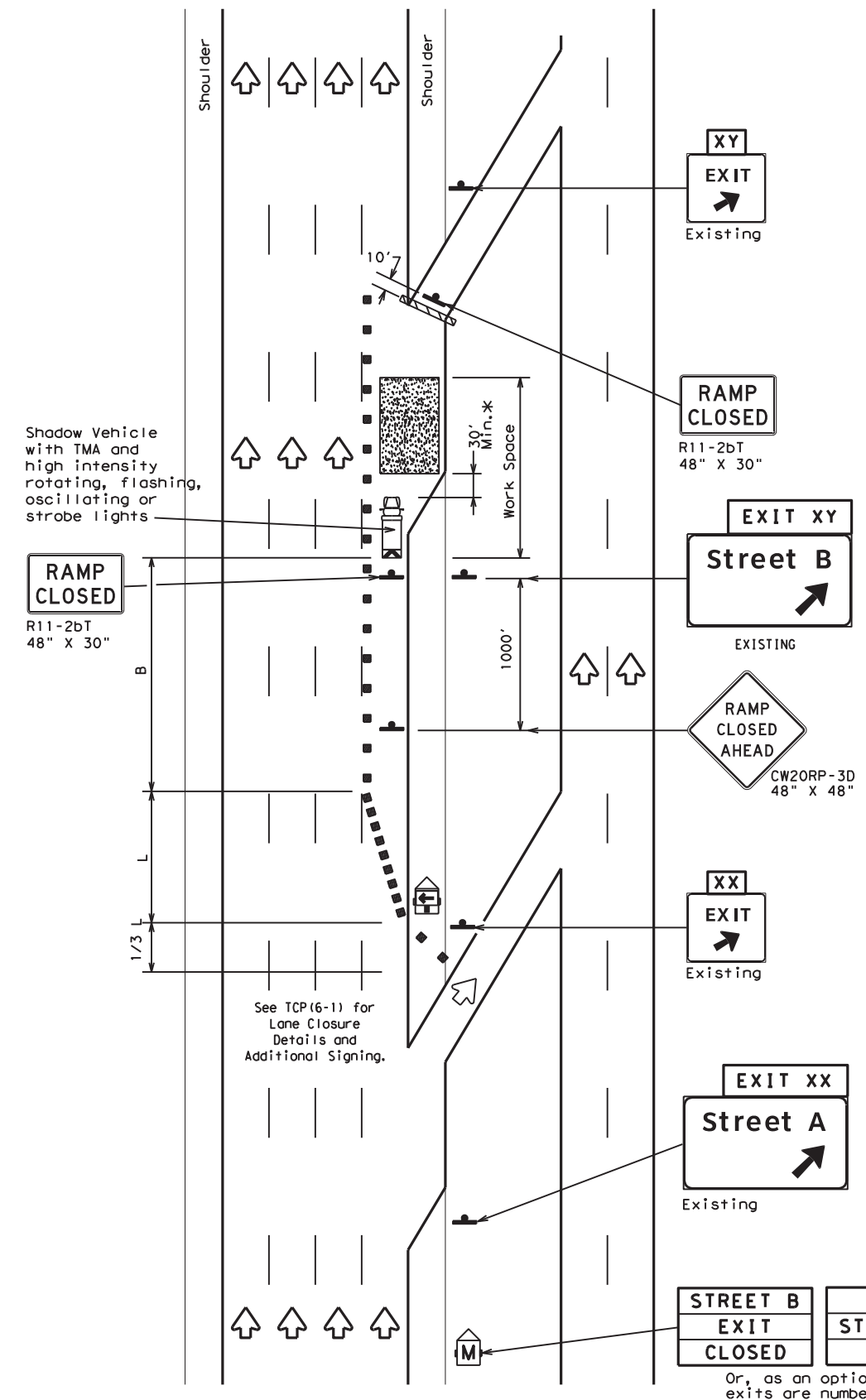

TCP (6-3b)  
EXIT RAMP CLOSED  
TRAFFIC EXITS PRIOR TO CLOSED RAMP

LEGEND			
	Type 3 Barricade		Channelizing Devices
	Heavy Work Vehicle		Truck Mounted Attenuator (TMA)
	Trailer Mounted Flashing Arrow Board		Portable Changeable Message Sign (PCMS)
	Sign		Traffic Flow
	Flag		Flagger

Posted Speed	Formula	Minimum Desirable Taper Lengths "L" **			Suggested Maximum Spacing of Channelizing Devices		Suggested Longitudinal Buffer Space "B"
		10' Offset	11' Offset	12' Offset	On a Taper	On a Tangent	
45	L = WS	450'	495'	540'	45'	90'	195'
50		500'	550'	600'	50'	100'	240'
55		550'	605'	660'	55'	110'	295'
60		600'	660'	720'	60'	120'	350'
65		650'	715'	780'	65'	130'	410'
70		700'	770'	840'	70'	140'	475'
75		750'	825'	900'	75'	150'	540'
80	800'	880'	960'	80'	160'	615'	

\*\* Taper lengths have been rounded off.  
L=Length of Taper (FT) W=Width of Offset (FT) S=Posted Speed (MPH)

TYPICAL USAGE				
MOBILE	SHORT DURATION	SHORT TERM STATIONARY	INTERMEDIATE TERM STATIONARY	LONG TERM STATIONARY
	✓	✓	✓	

- GENERAL NOTES:
- All traffic control devices illustrated are REQUIRED. Devices denoted with the triangle symbol may be omitted when stated elsewhere in the plans.

\*A shadow vehicle equipped with a Truck Mounted Attenuator is typically required. A shadow vehicle equipped with a TMA shall be used if it can be positioned 30' to 100' in advance of the area of crew exposure without adversely affecting the work performance.

Additional requirements for lane closures and advance signing shall be as shown on TCP (6-1) or as directed by the Engineer.

Texas Department of Transportation  
Traffic Operations Division Standard

TRAFFIC CONTROL PLAN  
WORK AREA BEYOND RAMP

TCP (6-3) - 12

FILE: tcp6-3.dgn	DN: TxDOT	CR: TxDOT	DW: TxDOT	CK: TxDOT
©TxDOT February 1994	CONT	SECT	JOB	HIGHWAY
REVISIONS	6435	38	001	IH10, etc
1-97 8-98	DIST	COUNTY	SHEET NO.	
4-98 8-12	BMT	JEFFERSON, etc	39	

DATE:  
FILE:

DISCLAIMER: The use of this standard is governed by the "Texas Engineering Practice Act". No warranty of any kind is made by TxDOT for any purpose whatsoever. TxDOT assumes no responsibility for the conversion of this standard to other formats or for incorrect results or damages resulting from its use.

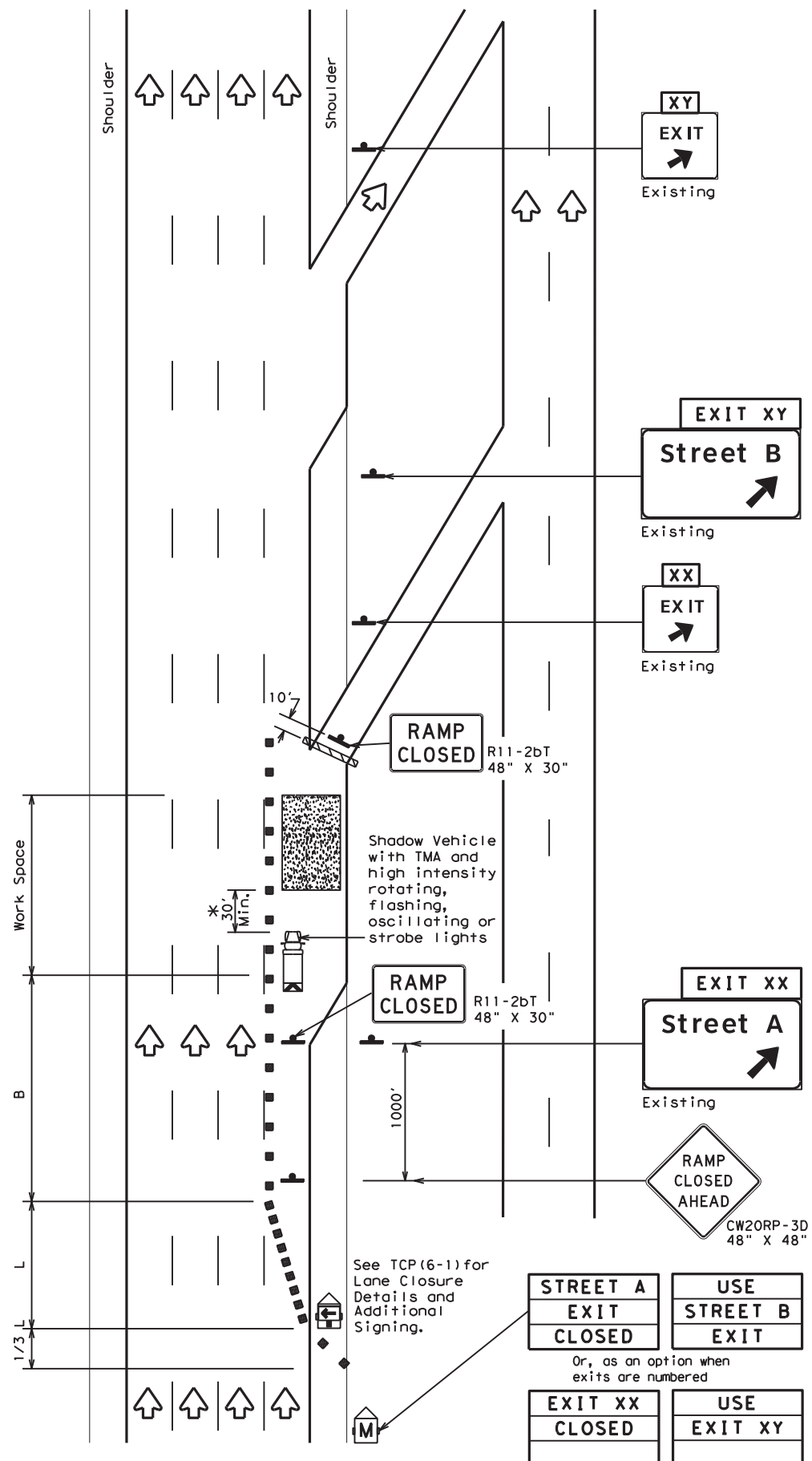

**TCP (6-4a)**  
**EXIT RAMP CLOSED**  
**TRAFFIC EXITS PAST CLOSED RAMP**

STREET A EXIT CLOSED	USE STREET B EXIT
EXIT XX CLOSED	USE EXIT XY

Or, as an option when exits are numbered

Place 1 mile (approx.) in advance of closed ramp.

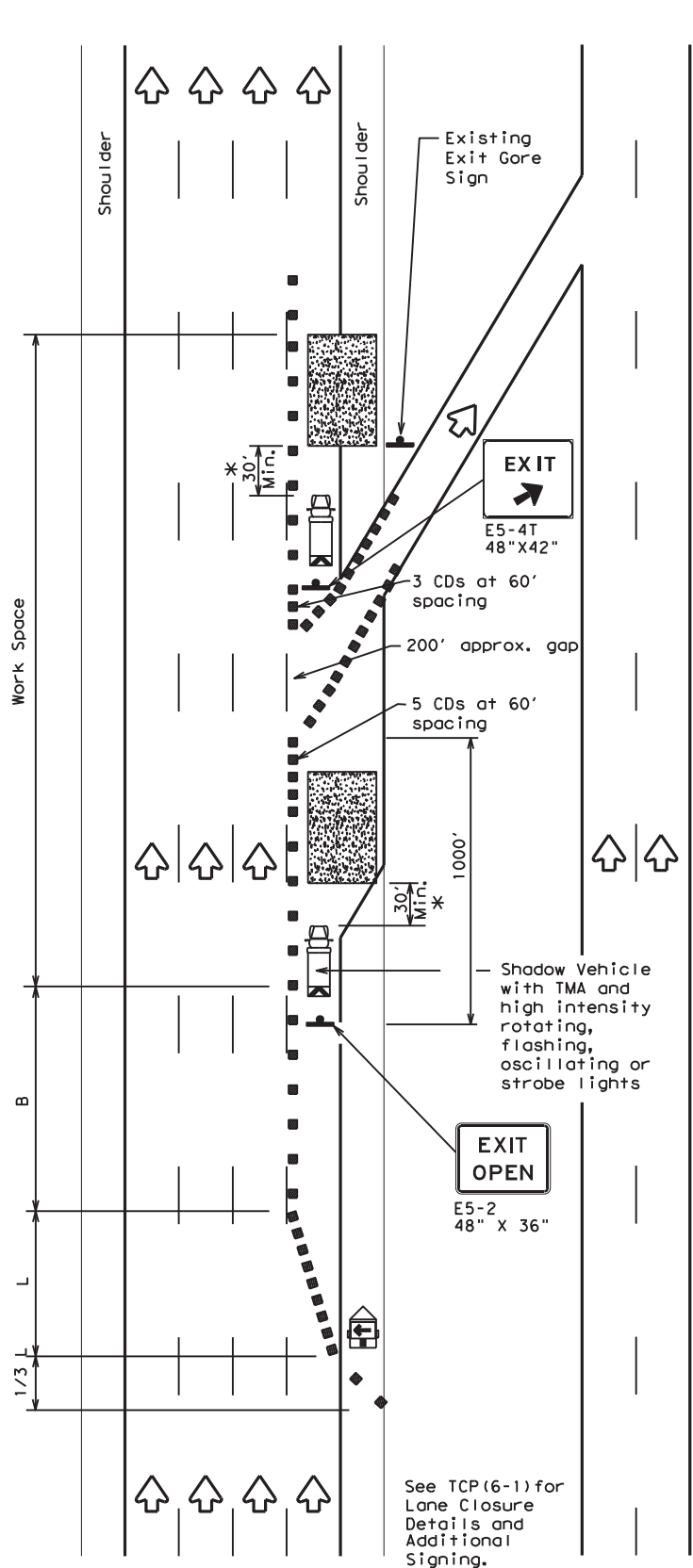

**TCP (6-4b)**  
**EXIT RAMP OPEN**

LEGEND			
	Type 3 Barricade		Channelizing Devices (CDs)
	Heavy Work Vehicle		Truck Mounted Attenuator (TMA)
	Trailer Mounted Flashing Arrow Board		Portable Changeable Message Sign (PCMS)
	Sign		Traffic Flow
	Flag		Flagger

Posted Speed	Formula	Minimum Desirable Taper Lengths "L"			Suggested Maximum Spacing of Channelizing Devices		Suggested Longitudinal Buffer Space "B"
		10' Offset	11' Offset	12' Offset	On a Taper	On a Tangent	
45	L = WS	450'	495'	540'	45'	90'	195'
50		500'	550'	600'	50'	100'	240'
55		550'	605'	660'	55'	110'	295'
60		600'	660'	720'	60'	120'	350'
65		650'	715'	780'	65'	130'	410'
70		700'	770'	840'	70'	140'	475'
75		750'	825'	900'	75'	150'	540'
80		800'	880'	960'	80'	160'	615'

\*\* Taper lengths have been rounded off.  
 L=Length of Taper (FT) W=Width of Offset (FT) S=Posted Speed (MPH)

TYPICAL USAGE				
MOBILE	SHORT DURATION	SHORT TERM STATIONARY	INTERMEDIATE TERM STATIONARY	LONG TERM STATIONARY
	✓	✓	✓	

**GENERAL NOTES**

- All traffic control devices illustrated are REQUIRED. Devices denoted with the triangle symbol may be omitted when stated elsewhere in the plans.
- See BC Standards for sign details.

\*A shadow vehicle equipped with a Truck Mounted Attenuator is typically required. A shadow vehicle equipped with a TMA shall be used if it can be positioned 30' to 100' in advance of the area of crew exposure without adversely affecting the work performance.

Additional requirements for lane closures and advance signing shall be as shown on TCP (6-1) or as directed by the Engineer.



**TRAFFIC CONTROL PLAN**  
**WORK AREA AT EXIT RAMP**

**TCP (6-4) - 12**

FILE: tcp6-4.dgn	DN: TxDOT	CR: TxDOT	DW: TxDOT	CK: TxDOT
©TxDOT February 1994	CONT	SECT	JOB	HIGHWAY
REVISIONS	6435	38	001	IH10, etc
1-97 8-98	DIST	COUNTY	SHEET NO.	
4-98 8-12	BMT	JEFFERSON, etc	40	

DATE:  
FILE:



DISCLAIMER: The use of this standard is governed by the "Texas Engineering Practice Act". No warranty of any kind is made by TxDOT for any purpose whatsoever. TxDOT assumes no responsibility for the conversion of this standard to other formats or for incorrect results or damages resulting from its use.

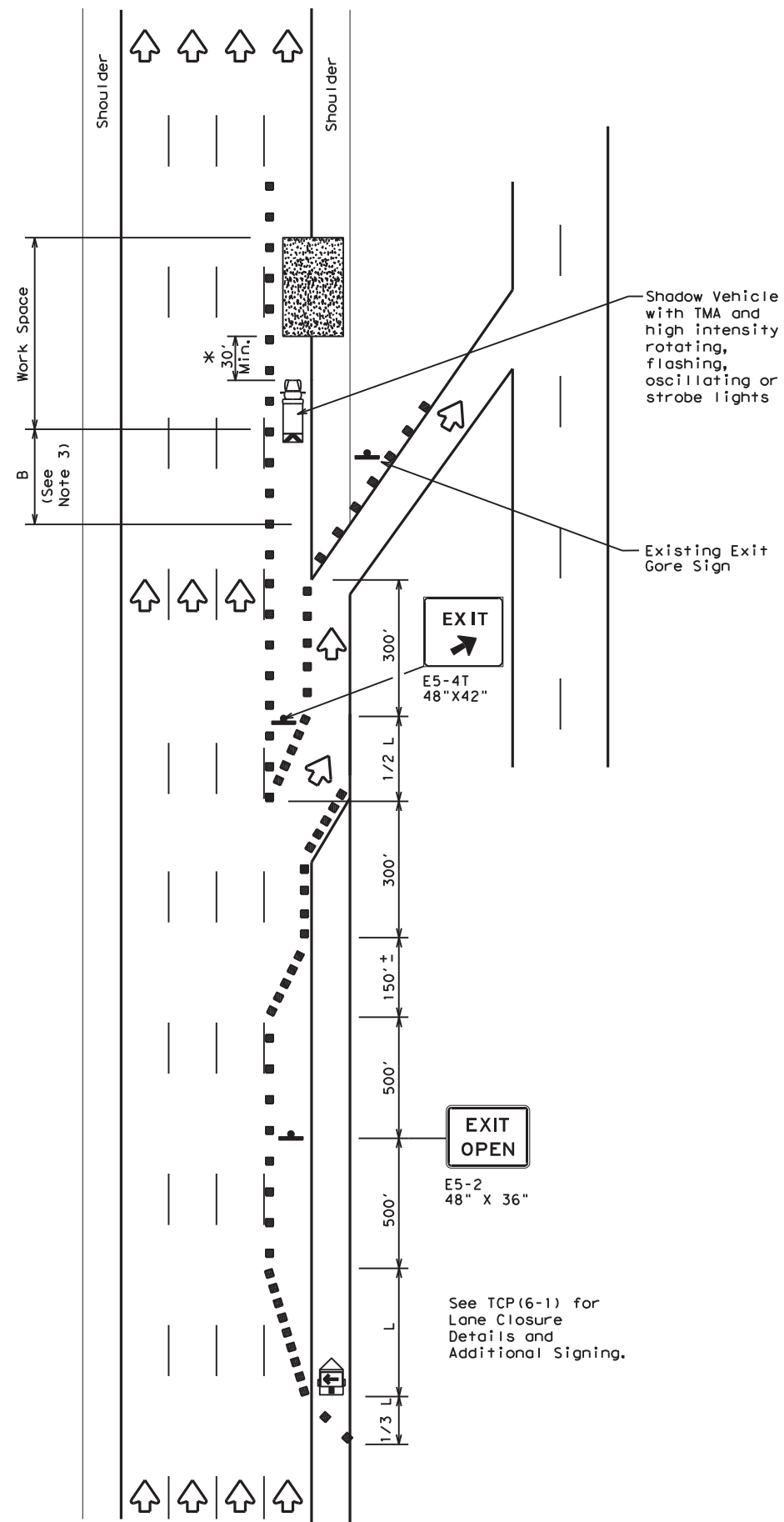

TCP (6-5a)  
**EXIT RAMP OPEN**

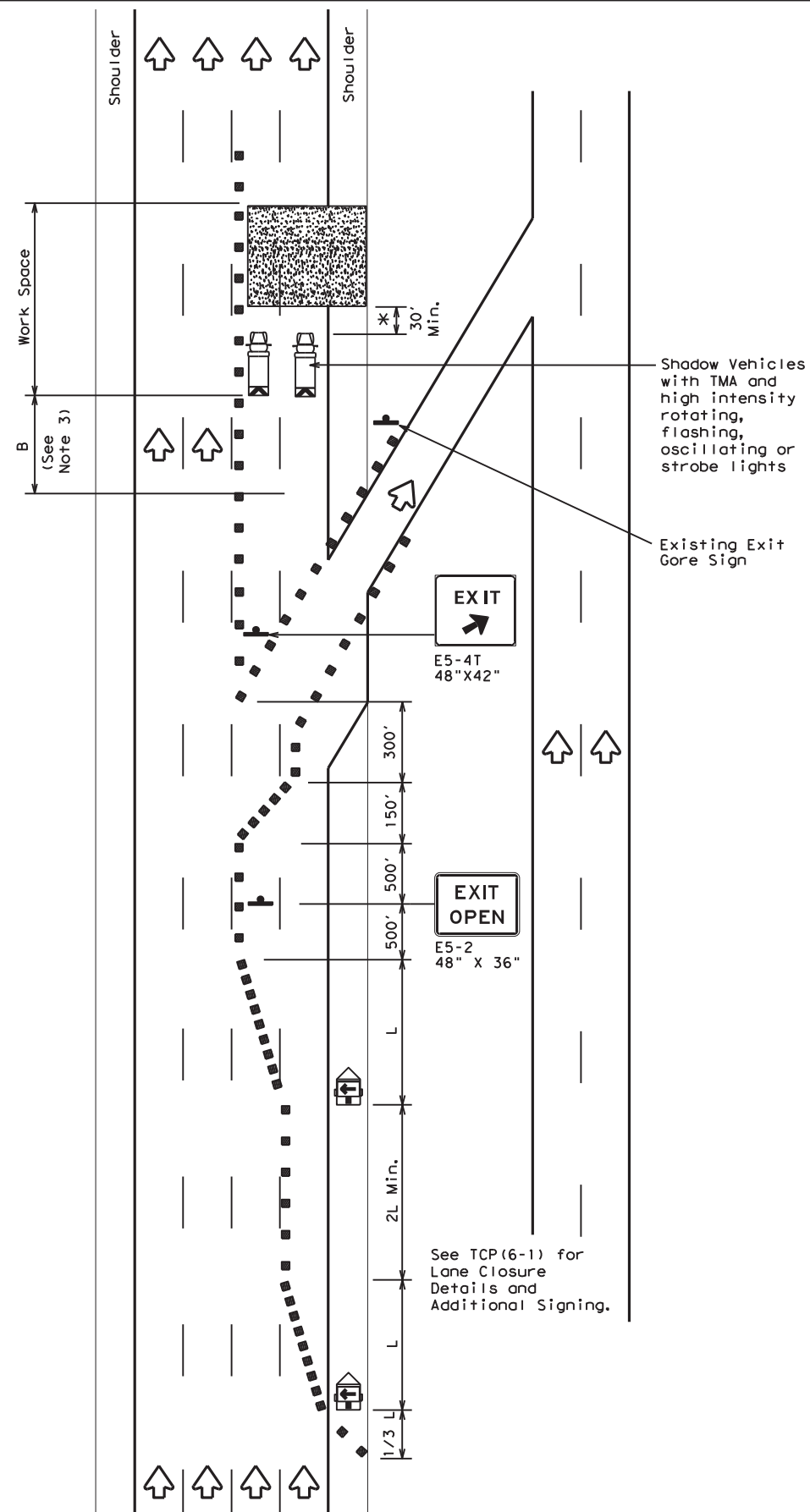

TCP (6-5b)  
**EXIT RAMP OPEN  
TWO LANE CLOSURE WITHIN  
1500' PAST EXIT RAMP**

LEGEND			
	Type 3 Barricade		Channelizing Devices
	Heavy Work Vehicle		Truck Mounted Attenuator (TMA)
	Trailer Mounted Flashing Arrow Board		Portable Changeable Message Sign (PCMS)
	Sign		Traffic Flow
	Flag		Flagger

Posted Speed	Formula	Minimum Desirable Taper Lengths "L" * * *			Suggested Maximum Spacing of Channelizing Devices		Suggested Longitudinal Buffer Space "B"
		10' Offset	11' Offset	12' Offset	On a Taper	On a Tangent	
45	L = WS	450'	495'	540'	45'	90'	195'
50		500'	550'	600'	50'	100'	240'
55		550'	605'	660'	55'	110'	295'
60		600'	660'	720'	60'	120'	350'
65		650'	715'	780'	65'	130'	410'
70		700'	770'	840'	70'	140'	475'
75		750'	825'	900'	75'	150'	540'
80		800'	880'	960'	80'	160'	615'

\* \* \* Taper lengths have been rounded off.  
L=Length of Taper (FT) W=Width of Offset (FT) S=Posted Speed (MPH)

TYPICAL USAGE				
MOBILE	SHORT DURATION	SHORT TERM STATIONARY	INTERMEDIATE TERM STATIONARY	LONG TERM STATIONARY
	✓	✓	✓	

**GENERAL NOTES**

- All traffic control devices illustrated are REQUIRED. Devices denoted with the triangle symbol may be omitted when stated elsewhere in the plans.
- See BC standards for sign details.
- If adequate longitudinal buffer length "B" does not exist between the work space and the exit ramp, consideration should be given to closing the ramp.

\*A shadow vehicle equipped with a Truck Mounted Attenuator is typically required. A shadow vehicle equipped with a TMA shall be used if it can be positioned 30' to 100' in advance of the area of crew exposure without adversely affecting the work performance.

Additional requirements for lane closures and advance signing shall be as shown on TCP (6-1) or as directed by the Engineer.



**TRAFFIC CONTROL PLAN  
WORK AREA BEYOND EXIT RAMP**

**TCP (6-5) - 12**

FILE: tcp6-5.dgn	DN: TxDOT	CK: TxDOT	DW: TxDOT	CR: TxDOT
©TxDOT February 1998	CONT	SECT	JOB	HIGHWAY
REVISIONS	6435	38	001	IH10, etc
1-97 8-98	DIST	COUNTY	SHEET NO.	
4-98 8-12	BMT	JEFFERSON, etc	41	

DATE:  
FILE:

DISCLAIMER: The use of this standard is governed by the "Texas Engineering Practice Act". No warranty of any kind is made by TxDOT for any purpose whatsoever. TxDOT assumes no responsibility for the conversion of this standard to other formats or for incorrect results or damages resulting from its use.

DATE: FILE:

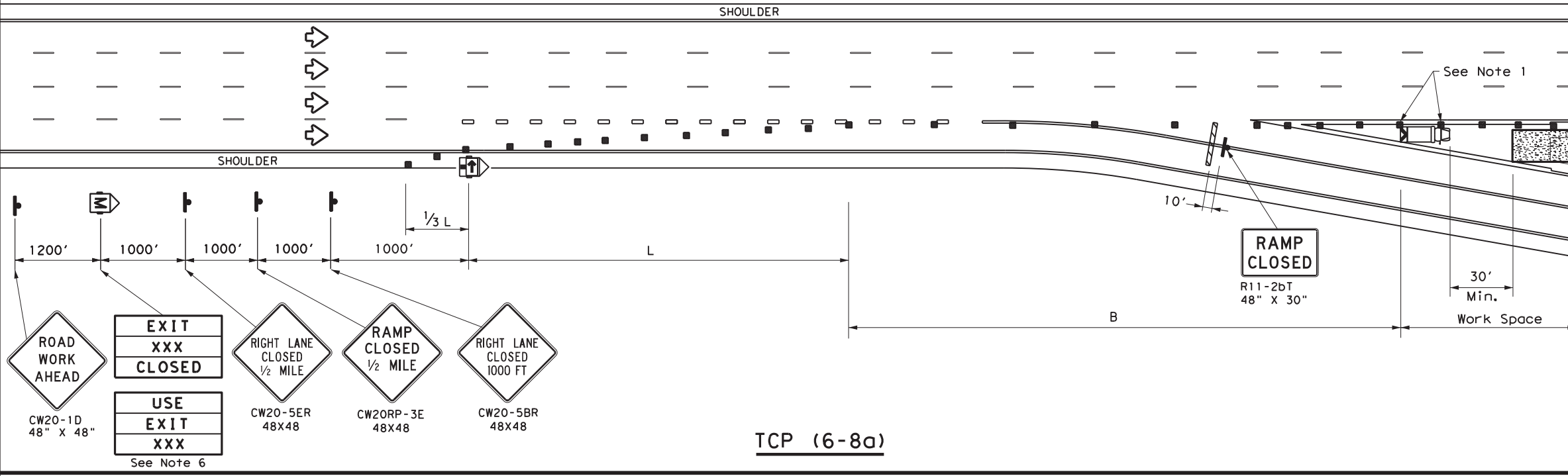

TCP (6-8a)

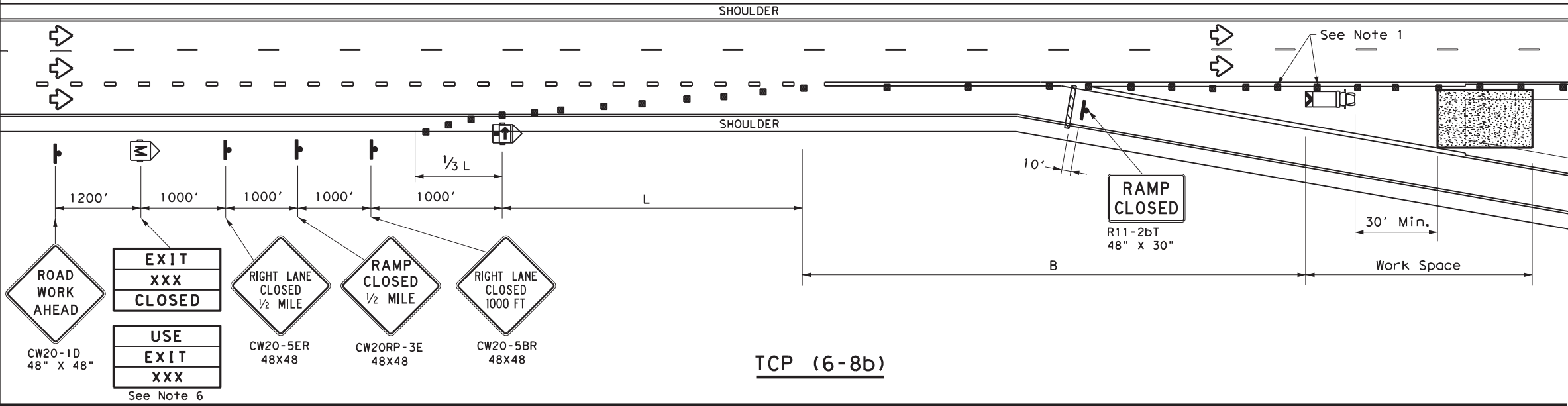

TCP (6-8b)

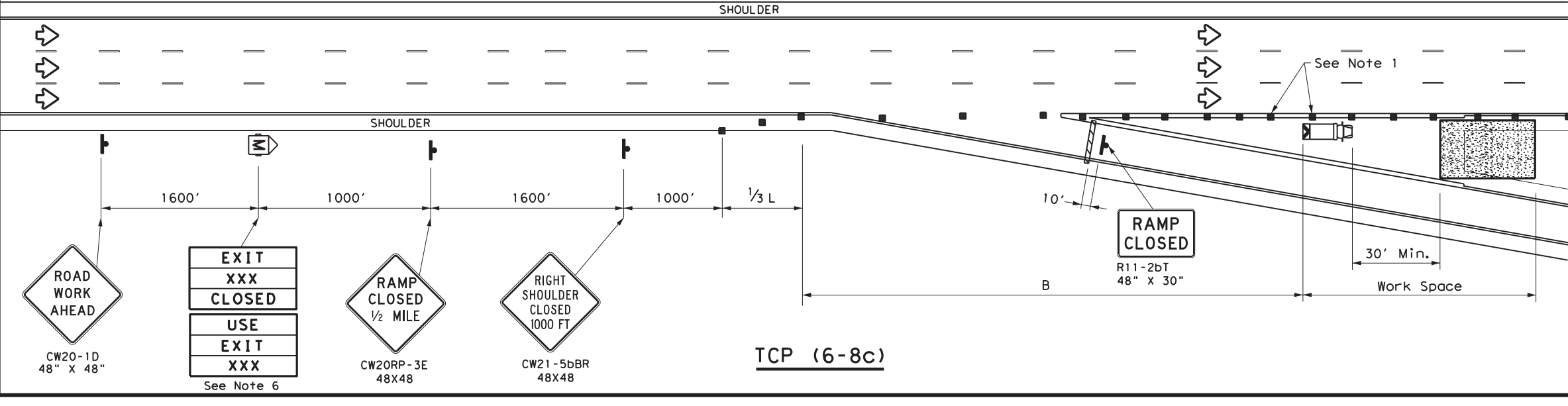

TCP (6-8c)

LEGEND			
	Type 3 Barricade		Channelizing Devices (CDs)
	Heavy Work Vehicle		Truck Mounted Attenuator (TMA)
	Trailer Mounted Flashing Arrow Board		Portable Changeable Message Sign (PCMS)
	Sign		Traffic Flow
	Flag		Flagger

Posted Speed	Formula	Minimum Desirable Taper Lengths "L" **			Suggested Maximum Spacing of Channelizing Devices		Suggested Longitudinal Buffer Space "B"
		10' Offset	11' Offset	12' Offset	On a Taper	On a Tangent	
45	L = WS	450'	495'	540'	45'	90'	195'
50		500'	550'	600'	50'	100'	240'
55		550'	605'	660'	55'	110'	295'
60		600'	660'	720'	60'	120'	350'
65		650'	715'	780'	65'	130'	410'
70		700'	770'	840'	70'	140'	475'
75		750'	825'	900'	75'	150'	540'
80		800'	880'	960'	80'	160'	615'

\*\* Taper lengths have been rounded off.  
 L=Length of Taper (FT) W=Width of Offset (FT)  
 S=Posted Speed (MPH)

TYPICAL USAGE				
MOBILE	SHORT DURATION	SHORT TERM STATIONARY	INTERMEDIATE TERM STATIONARY	LONG TERM STATIONARY
	✓	✓		

- GENERAL NOTES**
- Place channelizing devices in the gore at 20' spacing.
  - See the Standard Highway Sign Design for Texas (SHSD) for sign details.
  - The PCMS may be omitted when a permanent DMS sign is available in an appropriate location to display a similar message as called for on the PCMS.
  - When it is determined that a through lane should be closed in addition to the exit ramp, refer to TCP(6-4) for traffic control details.
  - Truck mounted attenuator is required.
  - The PCMS may be omitted if replaced with a "RAMP CLOSED" AHEAD (CW20RP-3D) Sign.
  - Roadway ADT should be greater than 10,000.

Texas Department of Transportation  
 Traffic Operations Division Standard

**WORK IN EXIT GORE FOR ADT GREATER THAN 10,000**

**TCP (6-8) - 14**

FILE: tcp6-8.dgn	DN: TxDOT	CK: TxDOT	DW: TxDOT	CK: TxDOT
© TxDOT February 2014	CONT	SECT	JOB	HIGHWAY
REVISIONS	6435	38	001	IH10, etc
	DIST	COUNTY	SHEET NO.	
	BMT	JEFFERSON, etc	42	

Warning sign and rumble strip sequence in opposite direction is same as below.

DISCLAIMER: The use of this standard is governed by the "Texas Engineering Practice Act". No warranty of any kind is made by TxDOT for any purpose whatsoever. TxDOT assumes no responsibility for the conversion of this standard to other formats or for incorrect results or damages resulting from its use.

Flagger to Flagger (Length of Work Area)	ADT	# of Rumble Strip Arrays
1/8 Mile	< 4,500	1
	≥ 4,500	2
1/4 Mile	< 3,500	1
	≥ 3,500	2
1/2 Mile	< 2,600	1
	≥ 2,600	2
1 Mile	< 1,600	1
	≥ 1,600	2
> 1 Mile	N/A	2

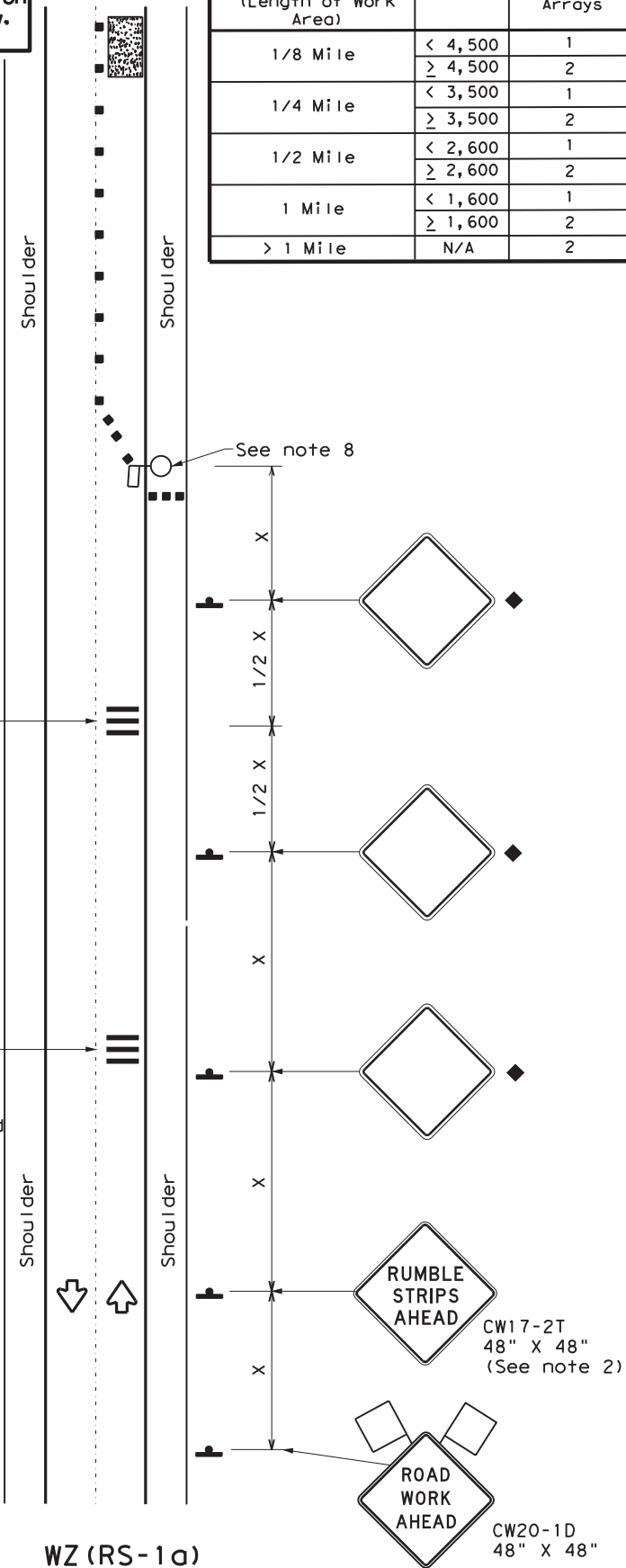

**RUMBLE STRIPS ON ONE-LANE TWO-WAY APPLICATION**

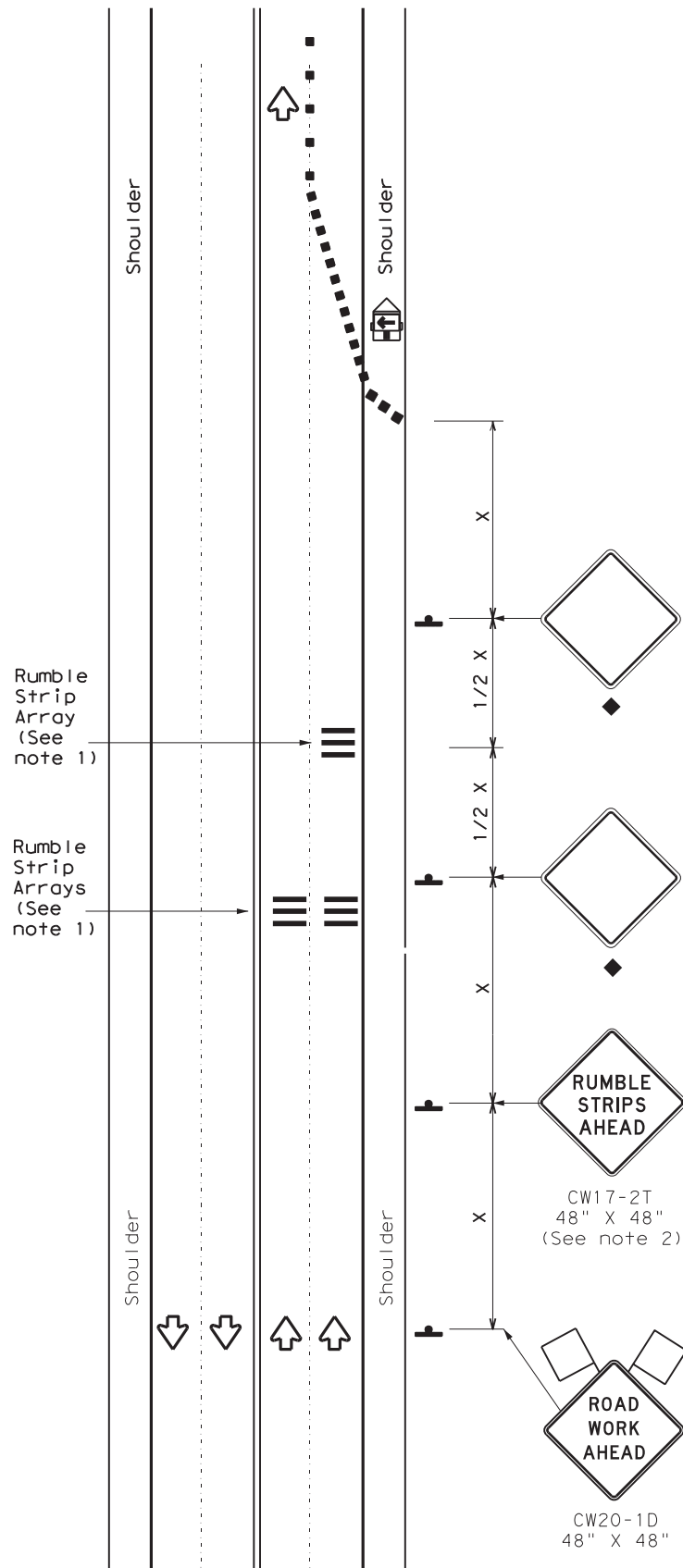

**RUMBLE STRIPS FOR LANE CLOSURE ON CONVENTIONAL ROADWAY**

**GENERAL NOTES**

- Each Rumble Strip Array should consist of three rumble strips spaced center to center at the spacing shown in Table 2, placed transverse across the lane at locations shown.
- The CW17-2T "RUMBLE STRIPS AHEAD" sign should be located after the CW20-1D "ROAD WORK AHEAD" sign and spaced as shown. If traffic is observed to be queuing, or is expected to queue beyond the Rumble Strips, the CW17-2T sign and the first Rumble Strip Array may be located upstream of the CW20-1D sign as necessary to provide needed warning.
- Temporary Rumble Strips will be considered subsidiary to Item 502, and shall be a product listed on the Compliant Work Zone Traffic Control Devices.
- Remove Temporary Rumble Strips before removing the advanced warning signs.
- Temporary Rumble Strips should not be used on horizontal curves, loose gravel, soft or bleeding asphalt, heavily rutted pavements or unpaved surfaces.
- Temporary Rumble Strips shall be installed and maintained as per manufacturer's recommendations.
- This standard sheet shall be used in conjunction with other appropriate TCP standard, TMUTCD typical application or project specific detail for the project.
- The one-lane two-way application may utilize a flagger, an Automated Flagger Assistance Device (AFAD) or a Portable Traffic Signal (PTS).
- Replace defective Temporary Rumble Strips as directed by the Engineer.
- Temporary Rumble Strips may be used on freeways or expressways based on engineering judgment and written direction from the Engineer.

Speed	Approximate distance between strips in an array
≤ 40 MPH	10'
> 40 MPH & ≤ 55 MPH	15'
= 60 MPH	20'
≥ 65 MPH	* 35' +

	Type 3 Barricade		Channelizing Devices
	Heavy Work Vehicle		Truck Mounted Attenuator (TMA)
	Trailer Mounted Flashing Arrow Panel		Portable Changeable Message Sign (PCMS)
	Sign		Traffic Flow
	Flag		Flagger

Posted Speed *	Formula	Minimum Desirable Taper Lengths **			Suggested Maximum Spacing of Channelizing Devices		Minimum Sign Spacing "X" Distance	Suggested Longitudinal Buffer Space "B"
		10' Offset	11' Offset	12' Offset	On a Taper	On a Tangent		
30	L = WS <sup>2</sup> / 60	150'	165'	180'	30'	60'	120'	90'
35		205'	225'	245'	35'	70'	160'	120'
40		265'	295'	320'	40'	80'	240'	155'
45	L = WS	450'	495'	540'	45'	90'	320'	195'
50		500'	550'	600'	50'	100'	400'	240'
55		550'	605'	660'	55'	110'	500'	295'
60		600'	660'	720'	60'	120'	600'	350'
65		650'	715'	780'	65'	130'	700'	410'
70		700'	770'	840'	70'	140'	800'	475'
75		750'	825'	900'	75'	150'	900'	540'

\* Conventional Roads Only  
 \*\* Taper lengths have been rounded off.  
 L=Length of Taper (FT) W=Width of Offset (FT)  
 S=Posted Speed (MPH)

MOBILE	SHORT DURATION	SHORT TERM STATIONARY	INTERMEDIATE TERM STATIONARY	LONG TERM STATIONARY
	✓	✓		

◆ Signs are for illustrative purposes only. Signs required may vary depending on the TCP, TMUTCD Typical Application, or project specific details for the project.  
 \* For posted speeds in excess of 65 MPH, it is recommended that spacing is increased as speed limits increase. Increasing space between rumble strips will improve effectiveness.

Texas Department of Transportation Traffic Safety Division Standard

## TEMPORARY RUMBLE STRIPS

### WZ (RS) - 22

FILE: wzrs22.dgn	DN: TxDOT	CK: TxDOT	DW: TxDOT	CK: TxDOT
© TxDOT November 2012	CONT	SECT	JOB	HIGHWAY
REVISIONS	6435	38	001	IH10, etc
2-14 1-22	DIST	COUNTY	SHEET NO.	
4-16	BMT	JEFFERSON, etc	43	

DATE:  
FILE:

DISCLAIMER: The use of this standard is governed by the "Texas Engineering Practice Act". No warranty of any kind is made by TxDOT for any purpose whatsoever. TxDOT assumes no responsibility for the conversion of this standard to other formats or for incorrect results or damages resulting from its use.

DATE:  
FILE:

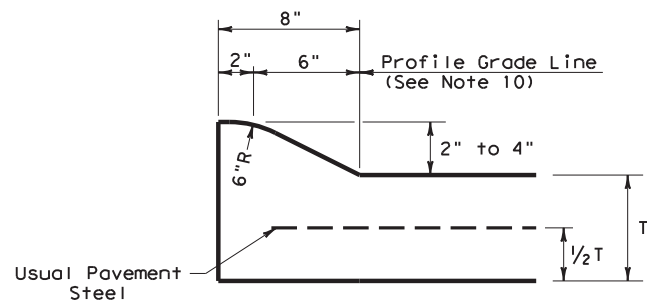

**TYPE I CURB (MONOLITHIC)**  
2" - 4" HEIGHT

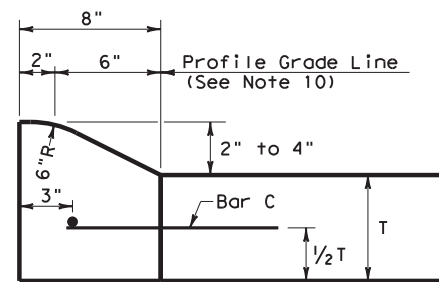

**TYPE I CURB**  
2" - 4" HEIGHT

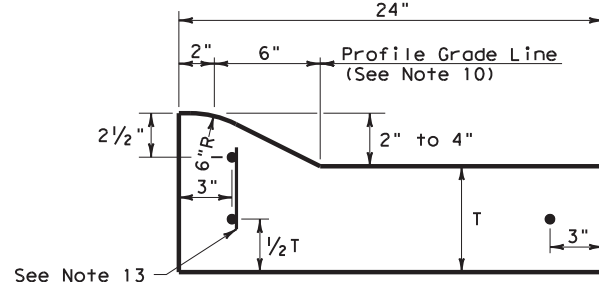

**TYPE I CURB AND GUTTER**  
2" - 4" HEIGHT

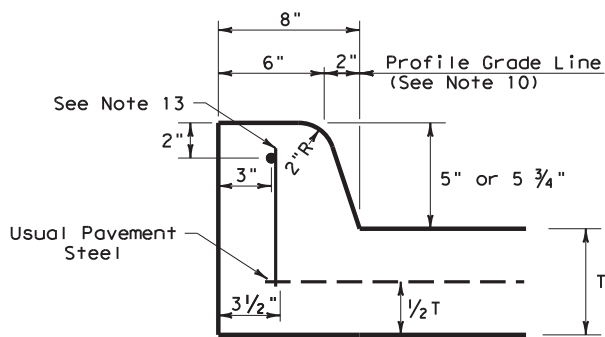

**TYPE II CURB (MONOLITHIC)**  
5" - 5 3/4" HEIGHT

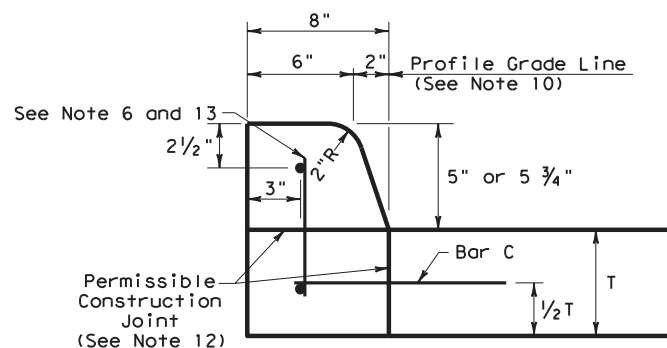

**TYPE II CURB**  
5" - 5 3/4" HEIGHT

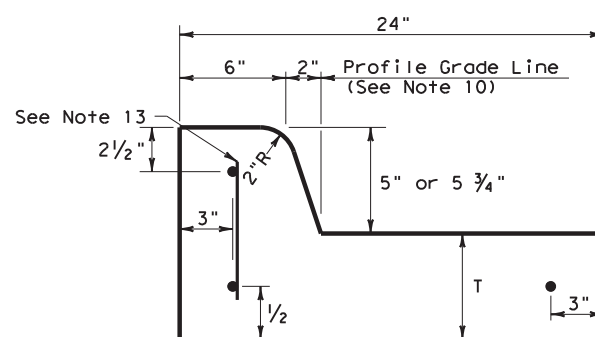

**TYPE II CURB AND GUTTER**  
5" - 5 3/4" HEIGHT

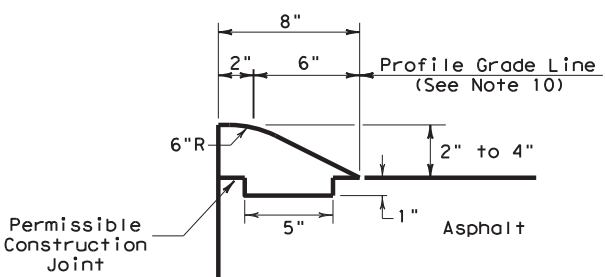

**TYPE III CURB (KEYED)**  
2" - 4" HEIGHT

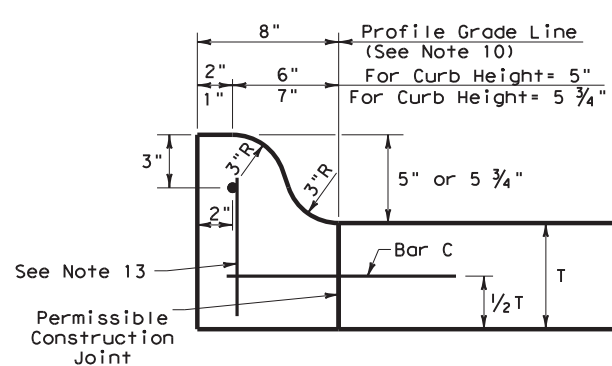

**TYPE IIa CURB**  
5" - 5 3/4" HEIGHT

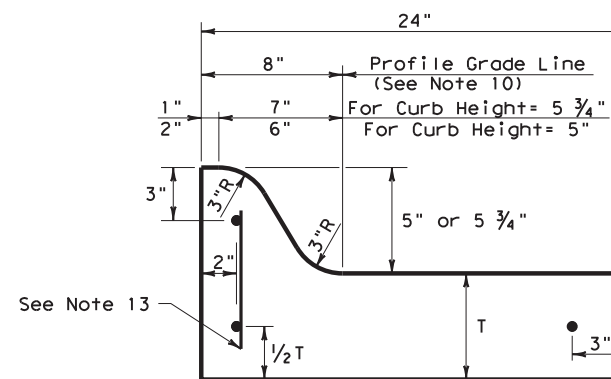

**TYPE IIa CURB AND GUTTER**  
5" - 5 3/4" HEIGHT

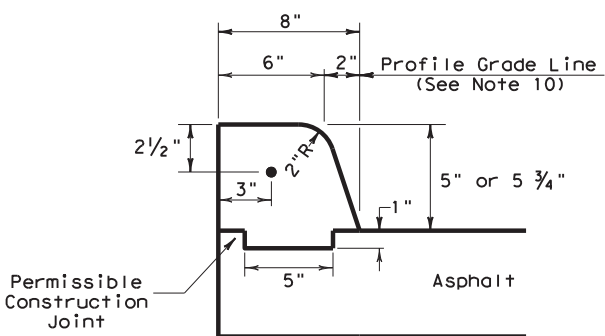

**TYPE IV CURB (KEYED)**  
5" - 5 3/4" HEIGHT

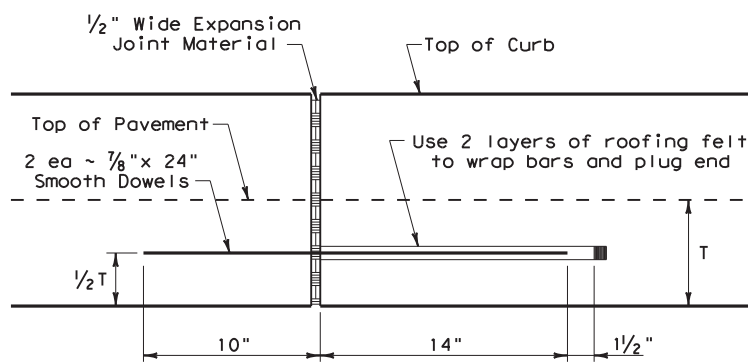

**EXPANSION JOINT DETAIL**

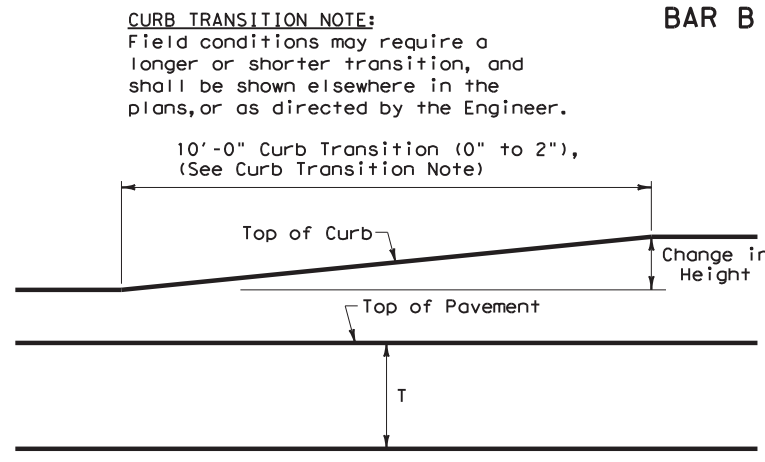

**CURB TRANSITION**

Note: To be paid for as Highest Curb

**GENERAL NOTES**

- All materials and construction shall be in accordance with Item 529, "Concrete Curb, Gutter, and Combined Curb and Gutter."
- Concrete shall be Class A.
- When reinforcing bars are used, they shall be No.4 unless otherwise shown. The use of fiber reinforced concrete in lieu of reinforcing steel is acceptable. Use fibers meeting the requirements of DMS 4550, "Fibers for Concrete," and dose fibers in accordance with Material Producers List (MPL) "Fibers for Class A and B Concrete Applications."
- Round exposed sharp edges with a rounding tool, to a minimum radius of 1/4 inch.
- All existing curbs and driveways to be removed shall be sawed or removed at existing joints.
- Where concrete curb is to be placed on existing concrete pavement, Bar B may be drilled and grouted in place, or may be inserted into fresh concrete.
- Expansion and contraction joints shall be constructed to match pavement joints in all curbs and curb and gutter adjacent to jointed concrete pavement. Where placement of curb or curb and gutter is not adjacent to concrete pavement, expansion joints shall be provided at structures, curb returns at streets, and at locations directed by The Engineer.
- Vertical and horizontal dowel bars and transverse reinforcing bars shall be placed at four feet C-C.
- Dimension 'T' shown is the thickness of concrete pavement. When curb is installed adjacent to flexible pavement dimension 'T' is 8" maximum.
- Usual profile grade line. Refer to typical sections and plan-profile sheets for exact locations.
- One-half inch expansion joint material shall be provided where curb or curb and gutter is adjacent to sidewalk or riprap.
- When horizontal permissible construction joints are used, the longitudinal pavement steel shall be placed in accordance with pavement details shown elsewhere in the plans. Reinforcing steel for curb section shall then conform to that required for concrete curb.
- Bar B placement as needed (typically at four ft. C-C) to support curb reinforcing steel during concrete placement.

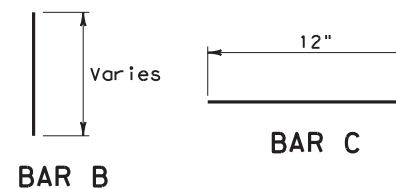

**BAR B**

**BAR C**

		Design Division Standard	
<h2>CONCRETE CURB AND GUTTER</h2>			
<h3>CCCG-22</h3>			
FILE: cccg21.dgn	DN: TxDOT	CK: AN	DW: CS
© TxDOT: JUNE 2022	CONT: 6435	SECT: 38	JOB: 001
REVISIONS	DIST: COUNTY		HIGHWAY: I110, etc
	BMT: JEFFERSON, etc		SHEET NO.: 44

DISCLAIMER: THE USE OF THIS STANDARD IS GOVERNED BY THE "TEXAS ENGINEERING PRACTICE ACT". NO WARRANTY OF ANY KIND IS MADE BY TXDOT FOR ANY PURPOSE WHATSOEVER. TXDOT ASSUMES NO RESPONSIBILITY FOR THE CONVERSION OF THIS STANDARD TO OTHER FORMATS OR FOR INCORRECT RESULTS OR DAMAGES RESULTING FROM ITS USE.

DATE: 2/28/2023  
FILE: T:\BMT\AO\01 - CSJ Project Files\6435-38-00\MBGF 2024\Des\gn\MBGF.dgn

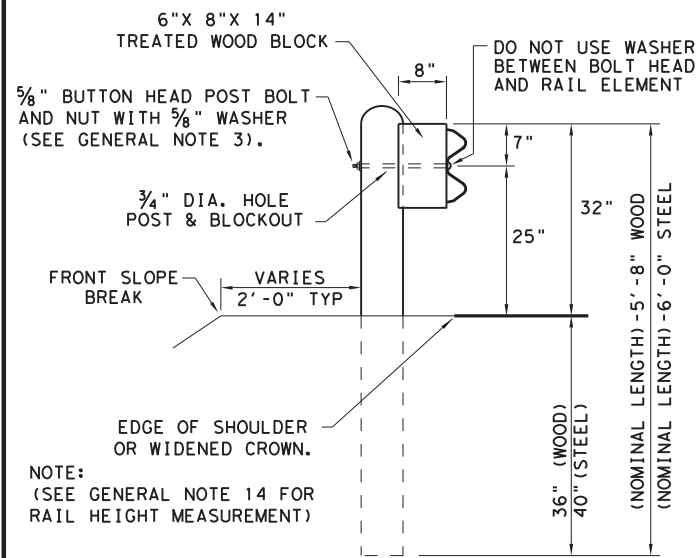

**TYPICAL POST PLACEMENT**

NOTE: (SEE GENERAL NOTE 14 FOR RAIL HEIGHT MEASUREMENT)

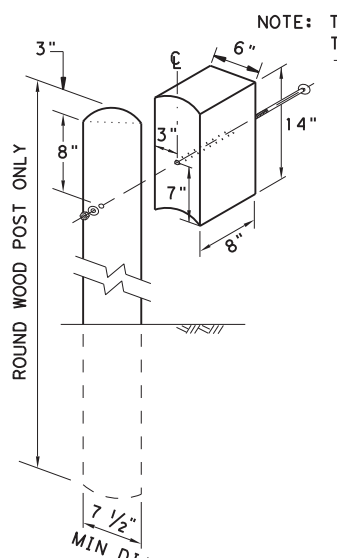

**WOOD BLOCK TO ROUND WOOD POST**

**WOOD BLOCK TO RECTANGULAR WOOD POST**

**ROUTED WOOD BLOCK TO I-BEAM STEEL POST**

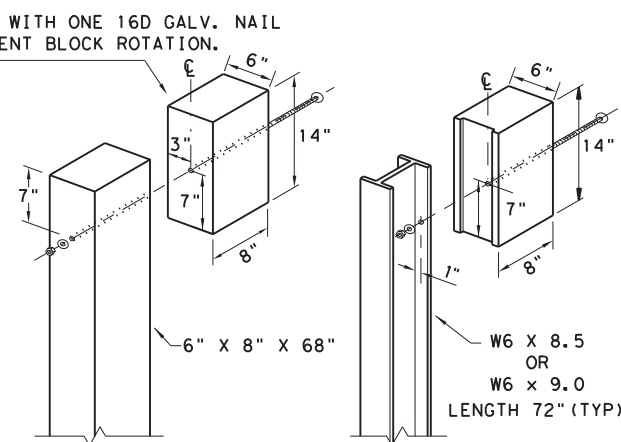

NOTE: \*\* "WOOD" INDICATES DIMENSIONS FOR BOTH ROUND AND RECTANGULAR WOOD POST SYSTEMS.

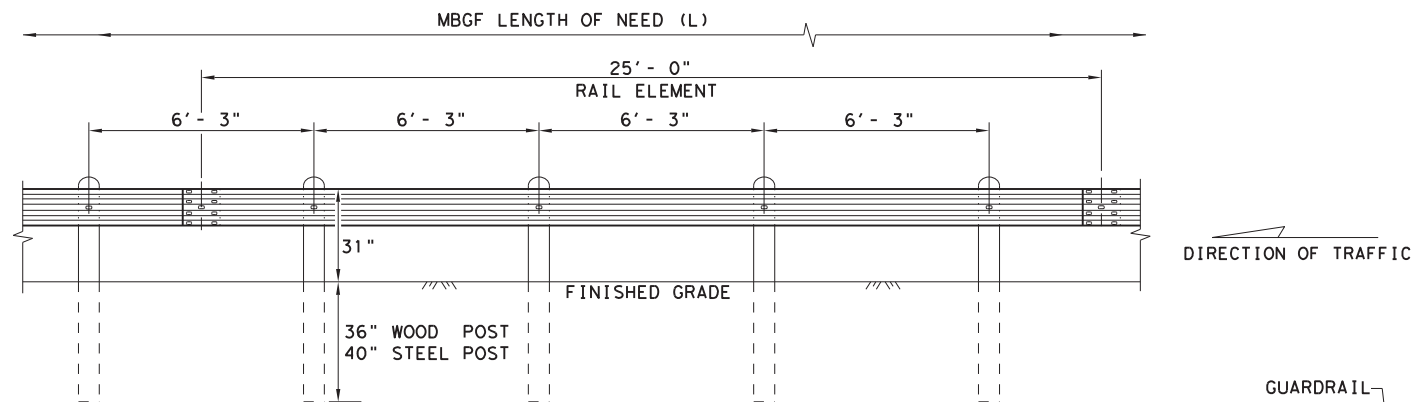

**ELEVATION MID-SPAN RAIL SPLICE**

SHOWING A 25' - 0" SECTION OF W-BEAM RAIL. (SEE GENERAL NOTE 2)

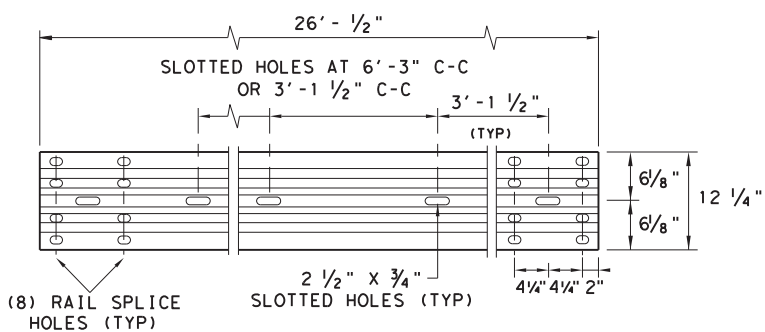

**ELEVATION 25' - 0" (NOM.) W-BEAM SECTION**

NOTES: SEE GENERAL NOTE 2 FOR ALLOWABLE RAIL TYPES. SEE RAIL SPLICE DETAIL FOR REQUIRED HARDWARE.

NOTE: FOUR TYPES OF BUTTON-HEAD GUARD RAIL BOLTS COME WITH A RECESSED NUT.

SPLICE BOLT LENGTH VARIES

FBB01 = 1 1/4"

FBB02 = 2"

POST & BLOCK LENGTH

FBB03 = 10"

FBB04 = 18"

**BUTTON HEAD BOLT**

NOTE: SEE GENERAL NOTE 3 FOR SPLICE & POST BOLT DETAILS.

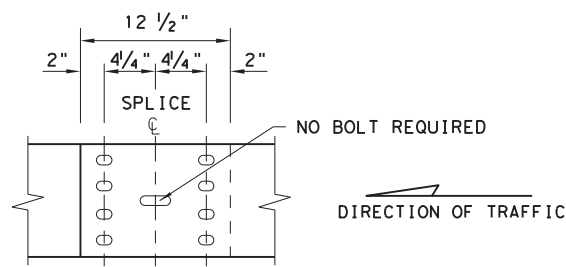

**MID-SPAN RAIL SPLICE DETAIL**

NOTE: GF(31), MID-SPAN RAIL SPLICES ARE REQUIRED WITH 6'-3" POST SPACINGS.

\* POST(S) MAY REQUIRE FIELD MODIFICATION TO ENSURE PROPER GUARDRAIL HEIGHT.

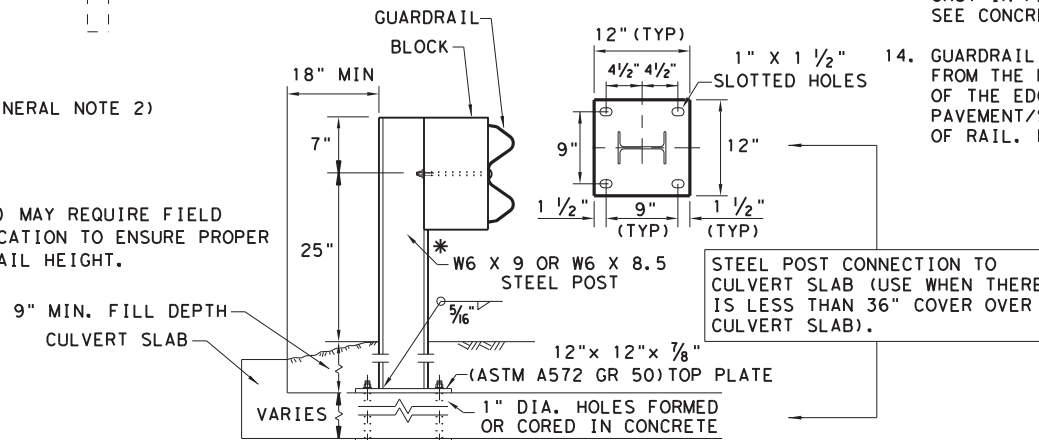

**LOW FILL CULVERT POST**

NOTE: TWO INSTALLATION OPTIONS.

1. **BOLT-THROUGH OPTION:** REQUIRES A 6" MIN. SLAB THICKNESS. 7/8" DIA (ASTM A449) HEAVY HEX BOLTS WITH TWO HARDENED WASHER EACH AND HEAVY HEX NUTS. NOTE: BOLT LENGTH = SLAB PLUS 2 1/4" MIN.

2. **EPOXY ANCHOR OPTION:** THIS OPTION MAY ONLY BE USED IF THE CULVERT SLAB IS 9" MIN. THICK. THREADED ANCHOR RODS MUST BE 7/8" DIA. ASTM A449 OR A193 GRADE B7 WITH HEAVY HEX NUT, AND ONE HARDENED WASHER EACH. EMBED ANCHOR RODS 6" WITH HILTI HIT RE 500 EPOXY ADHESIVE. OTHER TYPE III CLASS C EPOXY ADHESIVES MEETING THE REQUIREMENTS OF DMS-6100, "EPOXIES AND ADHESIVES", MAY BE USED IF IT CAN BE DEMONSTRATED THAT THEY MEET OR EXCEED THE STRENGTH OF HILTI HIT RE 500 WITH THE SAME EMBEDMENT DEPTH AND THREADED ROD DIA. FOLLOW THE MANUFACTURER'S REQUIREMENTS FOR INSTALLING EPOXIED THREADED RODS. EXTEND RODS 1/4" MIN. BEYOND NUT.

NOTE: CULVERTS OF 25 FT. OR LESS, SEE GF(31)LS STANDARD FOR "LONG SPAN" OPTION.

**GENERAL NOTES**

1. THE TYPE OF POST (ROUND WOOD POST, RECTANGULAR WOOD POST, OR STEEL POST) WILL BE AS SHOWN IN THE PLANS. THE EXACT POSITION OF MBGF SHALL BE SHOWN IN THE PLANS OR AS DIRECTED BY THE ENGINEER. STEEL POSTS TO BE GALVANIZED IN ACCORDANCE WITH ITEM 445, "GALVANIZING."
2. RAIL ELEMENTS SHALL MEET THE REQUIREMENTS OF ITEM 540, "METAL BEAM GUARD FENCE" EXCEPT AS MODIFIED IN THE PLANS. THE CONTRACTOR MAY FURNISH RAIL ELEMENTS OF 25' - 0", OR 12' - 6" (NOM.) LENGTHS. RAIL ELEMENTS MAY HAVE SLOTTED HOLES AT 3' - 1 1/2" C-C OR 6' - 3" C-C. A SPECIAL LENGTH OF RAIL MAY BE MANUFACTURED TO ACCOMMODATE THE DOWNSTREAM ANCHOR TERMINAL (DAT) AND THE TRANSITION SECTIONS OF GUARDRAIL.
3. BUTTON HEAD "POST BOLTS & NUTS" SHALL MEET THE REQUIREMENTS OF (ASTM A307), AND SHALL BE OF SUFFICIENT LENGTH TO EXTEND THROUGH THE FULL THICKNESS OF THE NUT AND 5/8" WASHER (FWC160) AND NOT MORE THAN 1" BEYOND IT. TRIM REMAINING BOLT LENGTH TO MEET REQUIRED LENGTH.
4. FITTINGS (BOLTS, NUTS, AND WASHERS) SHALL BE GALVANIZED IN ACCORDANCE WITH ITEM 445, "GALVANIZING." FITTINGS SHALL BE SUBSIDIARY TO THE BID ITEM.
5. CROWN SHALL BE WIDENED TO ACCOMMODATE THE METAL BEAM GUARD FENCE.
6. THE LATERAL APPROACH TO THE GUARD FENCE, SHALL HAVE A MAXIMUM SLOPE OF 1V:10H.
7. IF SHOWN ELSEWHERE IN THE PLANS OR AS DIRECTED BY THE ENGINEER, THE GUARD FENCE MAY BE FLARED AT A RATE OF 25:1 OR FLATTER.
8. UNLESS OTHERWISE SHOWN IN THE PLANS, GUARD FENCE PLACED IN THE VICINITY OF CURBS SHALL BE POSITIONED SO THAT THE FACE OF CURB IS LOCATED DIRECTLY BELOW OR BEHIND THE FACE OF THE RAIL. RAIL PLACED OVER CURBS SHALL BE INSTALLED SO THAT THE POST BOLT IS LOCATED APPROXIMATELY 25 INCHES ABOVE THE GUTTER PAN OR EDGE OF SHOULDER.
9. APPLICATIONS IN SOLID ROCK ARE ONLY ALLOWED WITH STEEL POSTS. IF SOLID ROCK IS ENCOUNTERED WITHIN 0 TO 18" OF THE FINISHED GRADE, DRILL A 24" DIA. HOLE, 24" INTO THE ROCK. IF SOLID ROCK IS ENCOUNTERED BELOW 18", DRILL A 12" DIA. HOLE, 12" INTO THE ROCK OR TO THE STANDARD EMBEDMENT DEPTH, WHICHEVER MAYBE LESS. ANY EXCESS POST LENGTH, AFTER MEETING THESE DEPTHS, MAY BE FIELD CUT TO ENSURE PROPER GUARDRAIL MOUNTING HEIGHT. BACKFILL WITH COARSE AGGREGATE MATERIAL.
10. POSTS SHALL NOT BE SET IN CONCRETE, OF ANY DEPTH.
11. SPECIAL FABRICATION WILL BE REQUIRED AT INSTALLATION LOCATIONS HAVING A CURVATURE OF LESS THAN 150 FT. RADIUS.
12. UNLESS OTHERWISE SHOWN IN THE PLANS, A COMPOSITE MATERIAL BLOCK THAT MEETS THE REQUIREMENTS OF DMS-7210, "COMPOSITE MATERIAL POSTS AND BLOCKS FOR METAL BEAM GUARD FENCE" MAY BE SUBSTITUTED FOR BLOCKS OF SIMILAR DIMENSIONS. THE CONSTRUCTION DIVISION, TXDOT MAINTAINS A MATERIAL PRODUCER LIST (MPL) FOR PRODUCERS OF MATERIALS CONFORMING TO DMS-7210 ONLY PRODUCERS ON THE MPL MAY FURNISH COMPOSITE MATERIAL BLOCKS.
13. FOR THE LOW FILL CULVERT OPTION, POSTS LOCATED PARTIALLY OR WHOLLY BETWEEN PRECAST BOX CULVERT UNITS, THE USE OF A CAST-IN-PLACE CONCRETE CLOSURE BETWEEN BOXES IS REQUIRED. THE LENGTH OF THE CAST-IN-PLACE CONCRETE CLOSURE SHALL ACCOMMODATE THE PLACEMENT OF THE LOW FILL CULVERT OPTION. SEE CONCRETE CLOSURE DETAILS ON BRIDGE STANDARD SCP-MD.
14. GUARDRAIL HEIGHT MEASUREMENT: WHEN THE GUARDRAIL IS LOCATED ABOVE PAVEMENT, MEASURE THE HEIGHT FROM THE PAVEMENT TO THE TOP OF THE W-BEAM RAIL. WHEN THE GUARDRAIL IS LOCATED UP TO 2 FT. OFF OF THE EDGE OF PAVEMENT OR FOR A PAVEMENT OVERLAY, USE A 10-FOOT STRAIGHTEDGE TO EXTEND THE PAVEMENT/SOULDER SLOPE TO THE BACK OF RAIL, MEASURE FROM THE BOTTOM OF STRAIGHTEDGE TO THE TOP OF RAIL. FOR GUARDRAIL LOCATED DOWN A 10:1 SLOPE, MEASURE FROM THE NOMINAL TERRAIN.

NOTE: TRANSITIONS TO BRIDGE RAILS OR TRAFFIC BARRIERS. SEE GF(31)TL3 TR STANDARD FOR HIGH-SPEED TL-3 TRANSITIONS. SEE GF(31)TL2 TR STANDARD FOR LOW-SPEED TL-2 TRANSITIONS.

		Design Division Standard	
<b>METAL BEAM GUARD FENCE</b> <b>TL-3 MASH COMPLIANT</b> <b>GF(31)-19</b>			
FILE: gf3119.dgn	DN: TXDOT	CK: KM	DW: VP
© TXDOT: NOVEMBER 2019	CONT	SECT	JOB
REVISIONS	6435	38	001
	DIST	COUNTY	SHEET NO.
	BMT	JEFFERSON, etc	45

DISCLAIMER: THE USE OF THIS STANDARD IS GOVERNED BY THE "TEXAS ENGINEERING PRACTICE ACT". NO WARRANTY OF ANY KIND IS MADE BY TxDOT FOR ANY PURPOSE WHATSOEVER. TxDOT ASSUMES NO RESPONSIBILITY FOR THE CONVERSION OF THIS STANDARD TO OTHER FORMATS OR FOR INCORRECT RESULTS OR DAMAGES RESULTING FROM ITS USE.

DATE: 2/28/2023  
 FILE: T:\BMT\AO\01 - CSJ Project Files\6435-38-001\MBGF 2024\Design\DGN\gf&mg.dgn

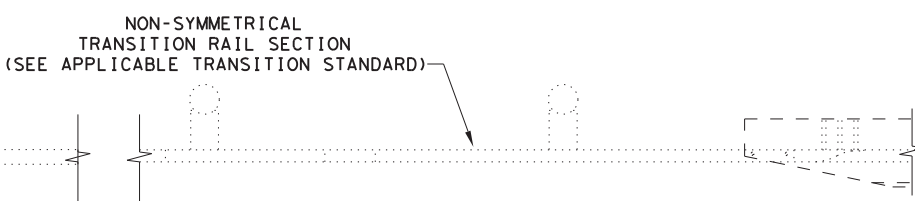
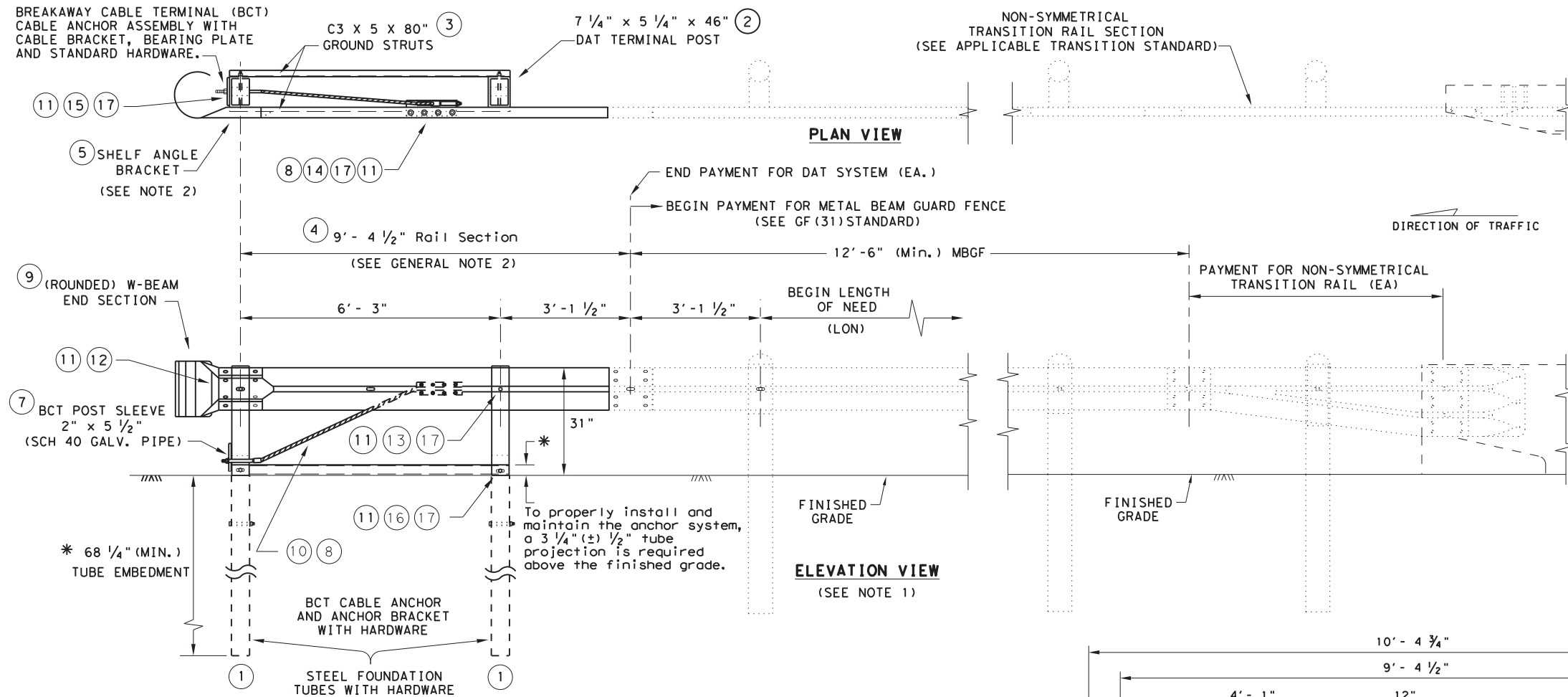

**DOWNSTREAM ANCHOR TERMINAL (DAT)**

NOTE: ONLY FOR DOWNSTREAM USE, WHEN LOCATED OUTSIDE THE HORIZONTAL CLEARANCE AREA OF OPPOSING TRAFFIC.

- GENERAL NOTES**
1. THE DETAIL SHOWN IS THE MINIMUM LENGTH OF NEED (LON) FOR A DOWNSTREAM ANCHOR TERMINAL (DAT) CONNECTED TO A CONCRETE RAIL.
  2. THE RAIL SECTION AT THE END POST IS SUPPORTED BY THE SHELF ANGLE BRACKET. THE RAIL ELEMENT IS NOT ATTACHED TO THE END POST.
  3. THE FOUNDATION TUBES SHALL NOT PROJECT MORE THAN 3 3/4" ABOVE THE FINISHED GRADE.
  4. ALL HARDWARE FOR DAT SHALL BE ASTM A307 UNLESS OTHERWISE SHOWN.
  5. REFER TO GF(31) SHEET FOR TERMINAL CONNECTION DETAILS.

**MOW STRIP INSTALLATION**  
 IF A MOW STRIP IS REQUIRED WITH THE DAT INSTALLATION THE LEAVE-OUT AREA AROUND THE STEEL FOUNDATION TUBES AND THE TWO CHANNEL STRUTS MAY BE OMITTED. THIS WILL REQUIRE A FULL POUR AT THE FOUNDATION TUBES.

#	(DAT) PARTS LIST	QTY
1	STEEL FOUNDATION TUBE	2
2	DAT TERMINAL POST	2
3	CHANNEL STRUT	2
4	TERMINAL RAIL ELEMENT	1
5	SHELF ANGLE BRACKET	1
6	BCT BEARING PLATE	1
7	BCT POST SLEEVE	1
8	GUARDRAIL ANCHOR BRACKET	1
9	(ROUNDED) W-BEAM END SECTION	1
10	BCT CABLE ANCHOR	1
11	RECESSED NUT, GUARDRAIL	20
12	1 1/4" BUTTON HEAD BOLT	4
13	10" BUTTON HEAD BOLT	2
14	5/8" X 2" HEX HEAD BOLT	8
15	5/8" X 8" HEX HEAD BOLT	4
16	5/8" X 10" HEX HEAD BOLT	2
17	5/8" FLAT WASHER	18

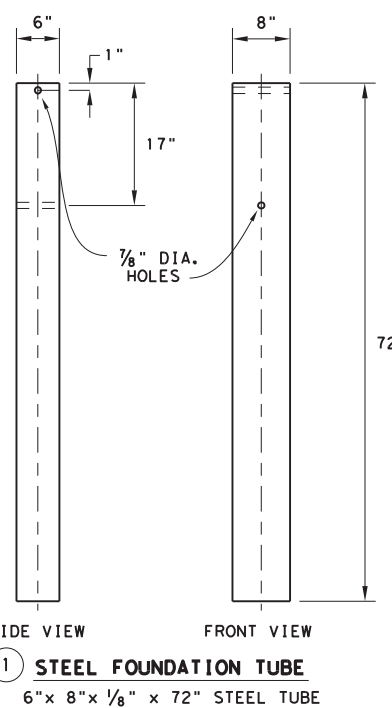
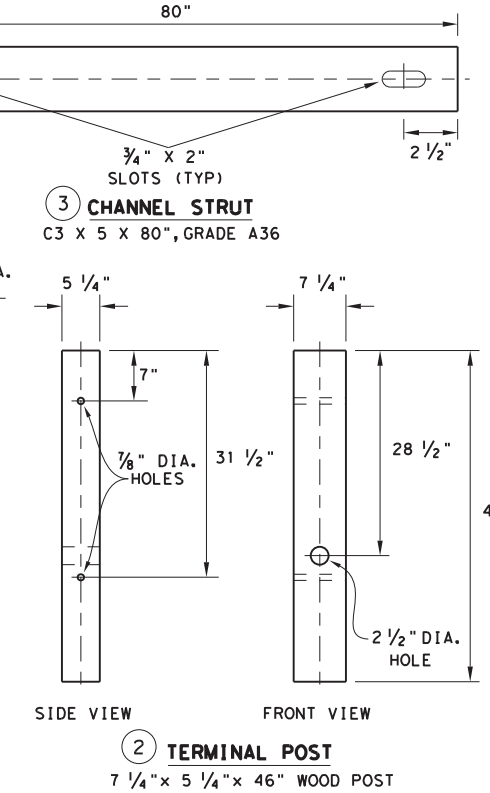
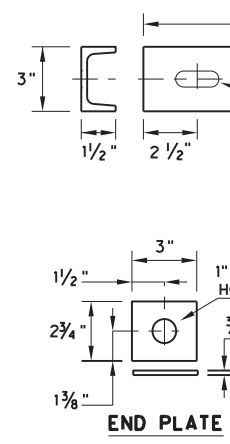
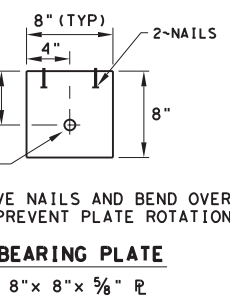
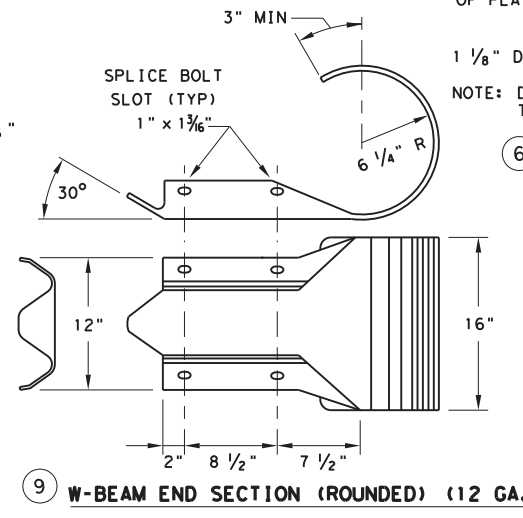
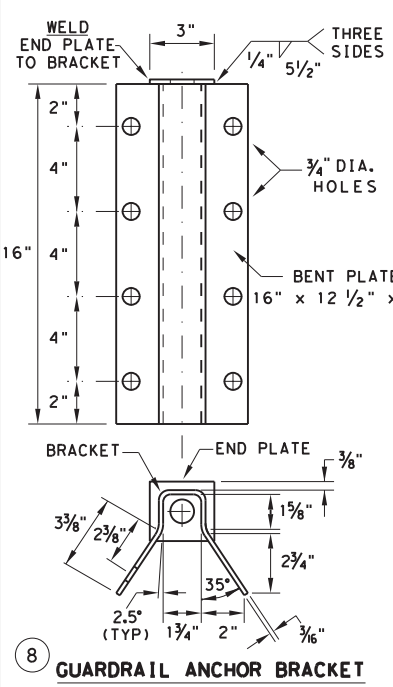
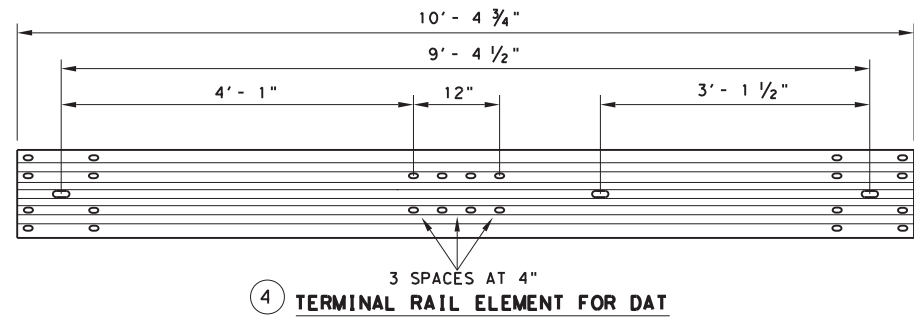

Design Division Standard

**METAL BEAM GUARD FENCE**  
**(DOWNSTREAM ANCHOR TERMINAL)**  
**TL-3 MASH COMPLIANT**  
**GF(31)DAT-19**

FILE: gf31dot19.dgn	DN: TxDOT	CK: KM	DW: VP	CK: CGL/AG
© TxDOT: NOVEMBER 2019 REVISIONS	CONT: 6435	SECT: 38	JOB: 001	HIGHWAY: IH10, etc
	DIST: BMT	COUNTY: JEFFERSON, etc	SHEET NO. 46	

DISCLAIMER: THE USE OF THIS STANDARD IS COVERED BY THE "TEXAS ENGINEERING PRACTICE ACT". NO WARRANTY OF ANY KIND IS MADE BY TXDOT FOR ANY PURPOSE WHATSOEVER. TXDOT ASSUMES NO RESPONSIBILITY FOR THE CONVERSION OF THIS STANDARD TO OTHER FORMATS OR FOR INCORRECT RESULTS OR DAMAGES RESULTING FROM ITS USE.

DATE: 2/28/2023  
 FILE: T:\BMT\AO\01 - CSJ Project Files\6435-38-001\MBGF 2024\Design\GN\gf&mg.dgn

NOTE: TOENAIL WITH ONE 16D GALV. NAIL TO PREVENT BLOCK ROTATION.

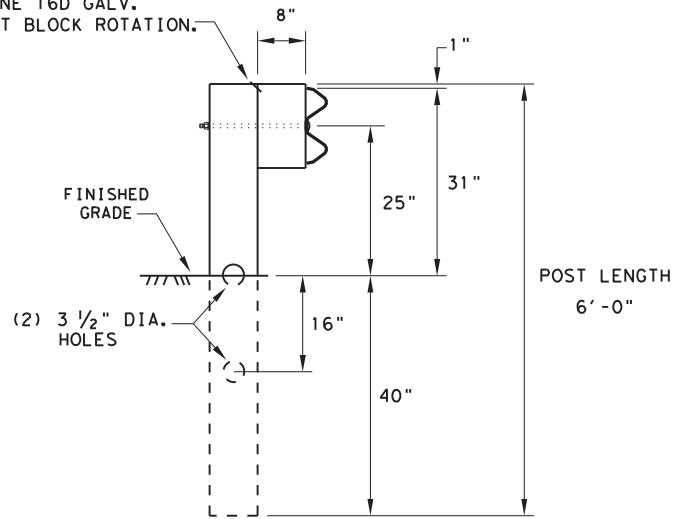

**RECTANGULAR CRT POST  
(6" X 8" X 6' LONG)**

(6) CRT REQUIRED  
SEE ELEVATION DETAIL FOR LOCATIONS

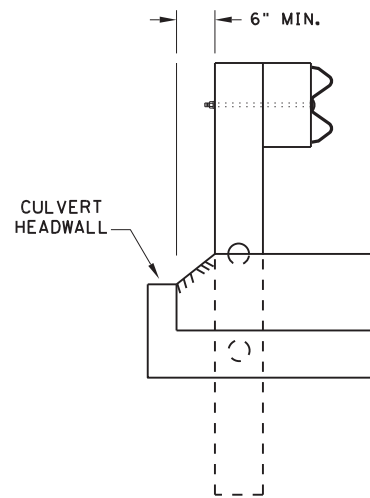

**LATERAL OFFSET BETWEEN THE  
GUARDRAIL AND THE CULVERT HEADWALL**

**GENERAL NOTES**

1. THE TYPE OF LINE POST (ROUND WOOD POST, RECTANGULAR WOOD POST, OR STEEL POST) WILL BE AS SHOWN IN THE PLANS. THE EXACT POSITION OF THE TRANSITIONS SHALL BE AS SHOWN IN THE PLANS OR AS DIRECTED BY THE ENGINEER. STEEL POSTS TO BE GALVANIZED IN ACCORDANCE WITH ITEM 445, "GALVANIZING."
2. RAIL ELEMENT SHALL MEET ALL REQUIREMENTS OF ITEM 540, "METAL BEAM GUARD FENCE" EXCEPT AS MODIFIED ON THE PLANS. THE CONTRACTOR MAY FURNISH RAIL ELEMENTS OF 12' - 6" OR 25' - 0" NOMINAL LENGTHS.
3. RAIL POST HOLES ARE OFFSET 3' - 1 1/2" FROM STANDARD GUARDRAIL TO ACCOMMODATE THE MIDSPAN SPLICING.
4. BUTTON HEAD "POST BOLTS & NUTS" SHALL MEET THE REQUIREMENTS OF (ASTM A307), AND SHALL BE OF SUFFICIENT LENGTH TO EXTEND THROUGH THE FULL THICKNESS OF THE NUT AND 5/8" WASHER (FWC160) AND NO MORE THAN 1" BEYOND IT.
5. FITTINGS (BOLTS, NUTS, AND WASHERS) SHALL BE GALVANIZED IN ACCORDANCE WITH ITEM 445, "GALVANIZING". FITTINGS SHALL BE SUBSIDIARY TO THE BID ITEM.
6. WHERE SOLID ROCK IS ENCOUNTERED, CONTACT THE DESIGN DIVISION FOR ADDITIONAL GUIDANCE. (512) 416-2678
7. POSTS SHALL NOT BE SET IN CONCRETE, OF ANY DEPTH.
8. REFER TO GF (31) STANDARD SHEET FOR ADDITIONAL DETAILS.
9. FLAME CUTTING OF HOLES IN GUARDRAIL SHALL NOT BE PERMITTED. IF YOU ENCOUNTER MIS-ALIGNED BOLT HOLES IN GUARDRAIL CONTACT THE DESIGN DIVISION FOR ADDITIONAL INFORMATION & OPTIONS.

NOTE: SEE GF (31) STANDARD FOR STANDARD LINE POSTS.

DIRECTION OF TRAFFIC

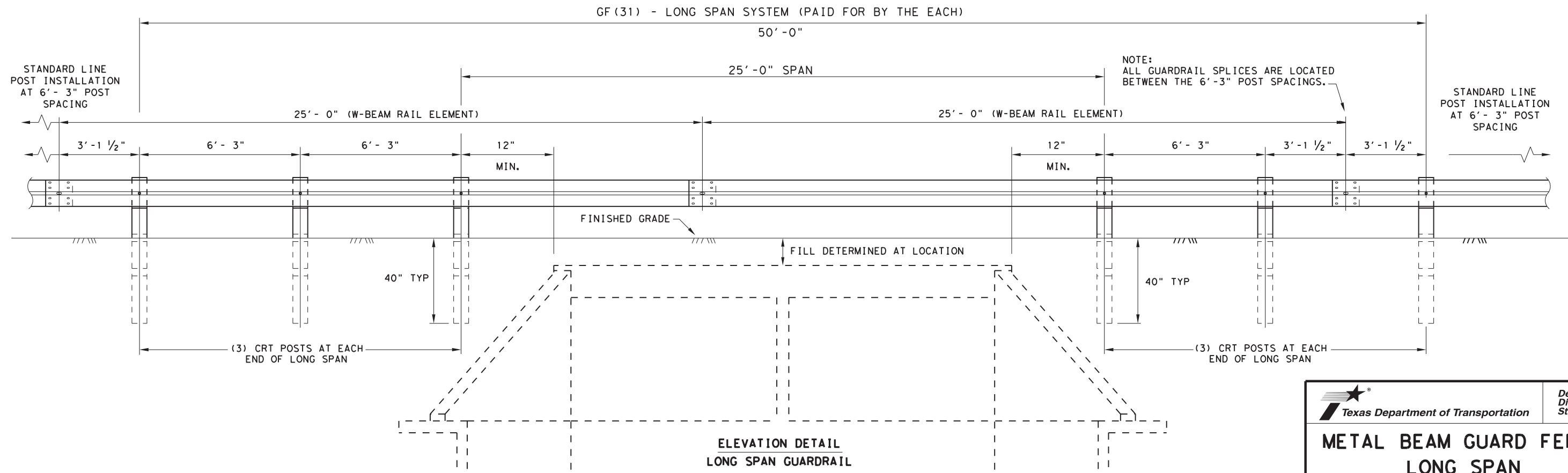

**ELEVATION DETAIL  
LONG SPAN GUARDRAIL**

		Design Division Standard	
<b>METAL BEAM GUARD FENCE LONG SPAN TL-3 MASH COMPLIANT</b>			
<b>GF (31) LS-19</b>			
FILE: gf31ls19.dgn	DN: TxDOT	CK: KM	DW: VP
© TXDOT: NOVEMBER 2019	CONT	SECT	JOB
REVISIONS	6435 38	001	IH10, etc
DIST	COUNTY		SHEET NO.
BMT	JEFFERSON, etc		47

DISCLAIMER: THE USE OF THIS STANDARD IS GOVERNED BY THE "TEXAS ENGINEERING PRACTICE ACT". NO WARRANTY OF ANY KIND IS MADE BY TxDOT FOR ANY PURPOSE WHATSOEVER. TxDOT ASSUMES NO RESPONSIBILITY FOR THE CONVERSION OF THIS STANDARD TO OTHER FORMATS OR FOR INCORRECT RESULTS OR DAMAGES RESULTING FROM ITS USE.

DATE: 2/28/2023  
 FILE: T:\BMT\AO\01 - CSJ Project Files\6435-38-001\MBGF 2024\Design\GN\gf&mg.dgn

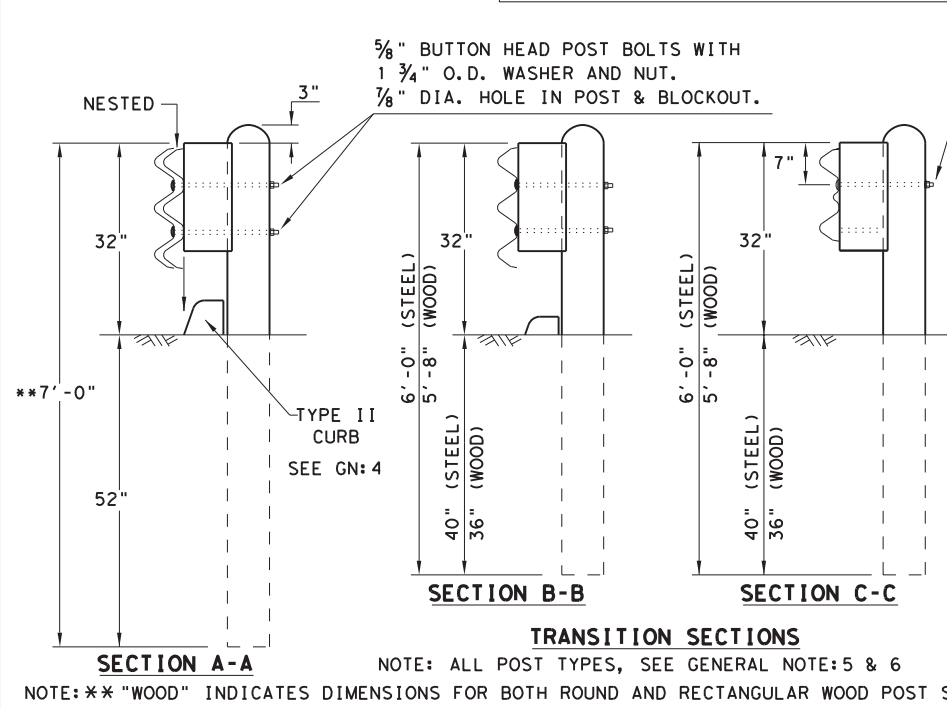
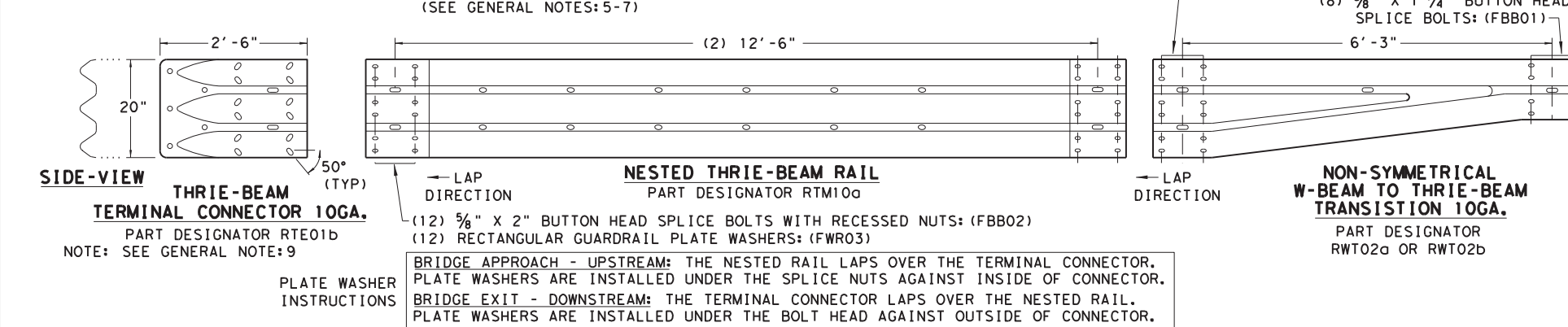
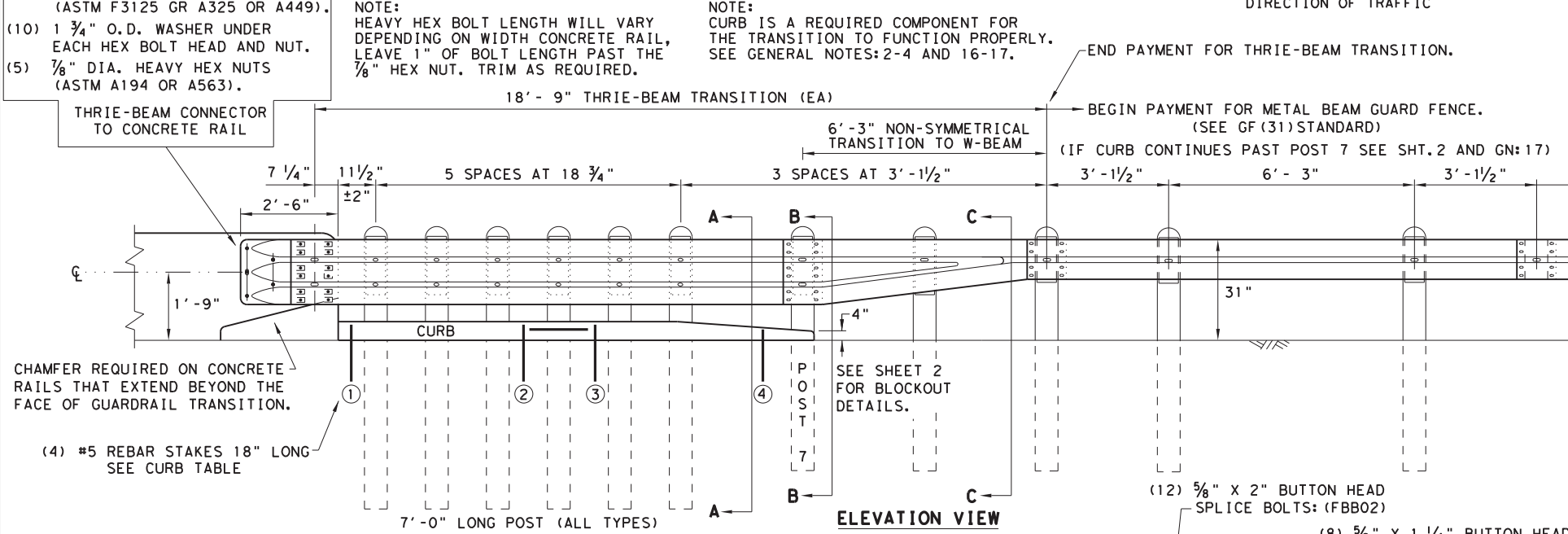
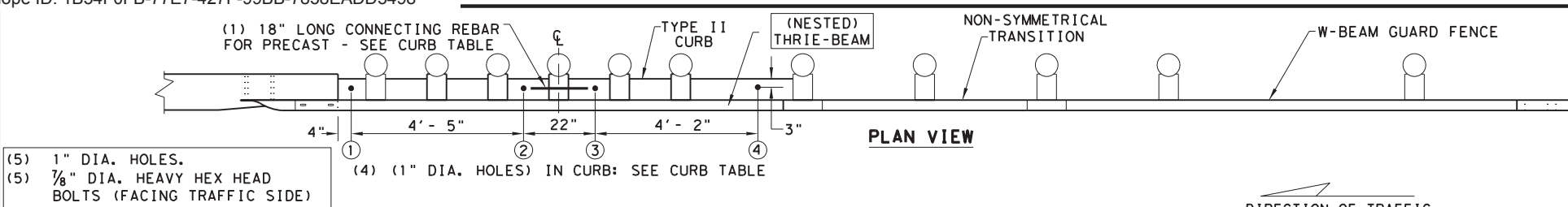

THRIE-BEAM TERMINAL - CURB TABLE	
PRECAST CURB FULL LENGTH EQUALS 12'- 2"	
THE PRECAST CURB MAY BE FORMED INTO TWO SECTIONS.	
CURB (1) LENGTH	5'- 8"
CURB (2) LENGTH	6'- 6"
TAPER CURB (2) TO A HEIGHT OF 4" AT POST 7	
CONNECTING PRECAST CURB SECTIONS (1) & (2):	
FORM OR CORE	1" DIA. HOLE 9" LONG INTO EACH CURB END.
USE	(1) #5 GR.60 REBAR 18" LONG TO CONNECT BOTH CURBS.
SECURING PRECAST OR CAST-IN-PLACE TO FINISHED GRADE *:	
FORM OR CORE	(4) 1" DIA. HOLES, SEE PLAN AND ELEVATION VIEWS FOR HOLE LOCATIONS. DRIVE (4) #5 GR.60 REBAR STAKES 18" LONG INTO THE GROUND AND 1/2" BELOW TOP OF CURB.
	FILL HOLES WITH APPROVED GROUT MIXTURE.

\* NOTES: NOT NEEDED FOR CAST-IN-PLACE. SEE TYPE II CURB DETAIL FOR REBAR AND COVER REQUIREMENTS. PERCUSSION DRILLING IS NOT PERMITTED WITH: TYPE II CURB, BRIDGE RAIL OR CONCRETE TRAFFIC RAIL.

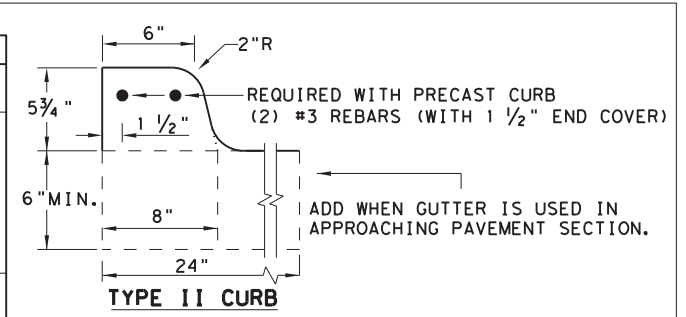

NOTE: OPTIONS FOR TYPE II CURB:  
 1. PRECAST  
 2. CAST-IN-PLACE

**GENERAL NOTES**

- CONTACT THE DESIGN DIVISION FOR DRAINAGE CUT OUT OPTIONS NEEDED WITHIN THE CURB SECTION OF THE THRIE-BEAM TRANSITION. (512) 416-2678
- CONCRETE CURB MAY BE CAST-IN-PLACE OR PRECAST AS SHOWN ON THIS SHEET. WHEN USED IN CONJUNCTION WITH THE THRIE-BEAM TRANSITIONS, CURB SHALL BE TYPE II (5- 3/4" HEIGHT); SEE CURRENT CCG STANDARD SHEET FOR FURTHER DETAILS. IF OTHER CURB HEIGHTS ARE SHOWN IN THE PLANS IN CONJUNCTION WITH THE TRANSITION, THE CURB HEIGHT MAY BE FROM 4" TO 8" WITH A RELATIVELY VERTICAL FACE. CONCRETE CURB SHALL BE CONTINUOUS TO THE SEVENTH POST UNLESS OTHERWISE SHOWN IN THE PLANS. SEE GENERAL NOTE:17 FOR CIRCUMSTANCES WHERE CURB CONTINUES PAST POST 7.
- CONCRETE CURB TYPE II SUBSIDIARY TO "METAL BEAM GUARD FENCE TRANSITION". IF NO ADDITIONAL CURB IS INDICATED BEYOND THE TRANSITION, THEN ANY CURB HEIGHT GREATER THAN 4" WILL BE TAPERED DOWN BEGINNING AT THE LAST 7 FT. POST TO A MAXIMUM HEIGHT OF 4" AT POST 7. IF SHOWN ELSEWHERE IN THE PLANS, ADDITIONAL CURB UNDERNEATH GUARDRAIL WILL BE PAID FOR BY THE LINEAR FOOT.
- UNLESS OTHERWISE SHOWN IN THE PLANS, TRANSITIONS SHALL BE PLACED WITH THE BLOCKOUT FACE IN FRONT OF OR DIRECTLY ABOVE THE CURB FACE. SEE SECTION A-A.
- FOR ROUND WOOD POST SYSTEMS, ALL ROUND WOOD POSTS SHALL BE 7 1/2" DIA. MINIMUM THROUGHOUT THE THRIE-BEAM TRANSITION.
- THE TYPE OF POST (ROUND WOOD POST, RECTANGULAR WOOD POST OR STEEL POST) WILL BE AS SHOWN IN THE PLANS. REFER TO GF (31) STANDARD SHEET.
- THE POST LENGTH SHALL BE MARKED ON ALL 7'- 0" LONG POSTS BY THE MANUFACTURER. THE MARK SHALL BE LOCATED WITHIN THE TOP 1 FT. REGION OF THE POST, AT LEAST 5/8" IN HEIGHT, AND VISIBLE AFTER INSTALLATION. WOODEN POSTS SHALL BE MARKED WITH A BRAND, AND STEEL POSTS WITH A STENCIL BEFORE GALVANIZING.
- POSTS SHALL NOT BE SET IN CONCRETE, OF ANY DEPTH.
- RAIL ELEMENTS SHALL MEET THE REQUIREMENTS OF ITEM 540, "METAL BEAM GUARD FENCE" EXCEPT AS MODIFIED ON THE PLANS. THE THRIE-BEAM TERMINAL CONNECTOR AND THE THRIE-BEAM TRANSITION TO W-BEAM SHALL BE OF THE SAME MATERIAL, BUT SHALL NOT BE LESS THAN 10 GAUGE. CONTRACTOR SHALL VERIFY THAT THE LOCATIONS OF BOLT HOLES MATCH THOSE IN THE THRIE-BEAM TERMINAL CONNECTOR PRIOR TO ORDERING MATERIALS.
- BUTTON HEAD "POST BOLTS & NUTS" SHALL MEET THE REQUIREMENTS OF (ASTM A307), AND SHALL BE OF SUFFICIENT LENGTH TO EXTEND THROUGH THE FULL THICKNESS OF THE NUT AND 5/8" WASHER (FWC16a) AND NOT MORE THAN 1" BEYOND IT. TRIM REMAINING BOLT LENGTH TO MEET REQUIRED LENGTH.
- FITTINGS (BOLTS, NUTS, AND WASHERS) SHALL BE GALVANIZED IN ACCORDANCE WITH ITEM 445, "GALVANIZING". FITTINGS SHALL BE SUBSIDIARY TO THE BID ITEM.
- CROWN SHALL BE WIDENED TO ACCOMMODATE TRANSITIONS.
- WHERE SOLID ROCK IS ENCOUNTERED, CONTACT THE DESIGN DIVISION FOR ADDITIONAL GUIDANCE. (512) 416-2678
- UNLESS OTHERWISE SHOWN IN THE PLANS, A COMPOSITE MATERIAL BLOCK THAT MEETS THE REQUIREMENTS OF DMS-7210, "COMPOSITE MATERIAL POSTS AND BLOCKS FOR METAL BEAM GUARD FENCE" MAY BE SUBSTITUTED FOR BLOCKS OF SIMILAR DIMENSIONS. TxDOT'S MATERIALS AND TESTS DIVISION MAINTAINS A MATERIAL PRODUCER LIST (MPL) FOR PRODUCERS OF MATERIALS CONFORMING TO DMS-7210. ONLY PRODUCERS ON THE MPL CAN FURNISH COMPOSITE MATERIAL BLOCKS.
- REFER TO GF (31) STANDARD SHEET & BRIDGE RAILING DETAILS FOR ADDITIONAL DETAILS.
- THE INSTALLATION OF THE TYPE II CURB IS CRITICAL FOR THE PERFORMANCE OF THE THRIE-BEAM TRANSITION SYSTEM. THE CURB PREVENTS (VEHICLE WHEEL SNAGGING) AT THE CONCRETE RAIL AND IS REQUIRED TO MEET MASH CRASH TEST CRITERIA.
- IF CURB EXTENDS BEYOND POST 7, 25' OF NESTED W-BEAM GUARDRAIL SHALL BE INSTALLED BEYOND THE PAY LIMITS OF THRIE-BEAM TRANSITION SECTION, (SEE SHT.2). PAYMENT FOR THIS 25' SECTION WILL BE BY LINEAR FOOT, PAY ITEM "0540 6XXX MTL W-BEAM GD FEN (NESTED) (TIM POST)" OR "540 6XXX MTL W-BEAM GD FEN (NESTED) (STEEL POST)" AS APPLICABLE FOR POST TYPE. SEE SHT.2 FOR ADDITIONAL INFORMATION.

**HIGH-SPEED TRANSITION**  
SHEET 1 OF 2

		Design Division Standard
<b>METAL BEAM GUARD FENCE THRIE-BEAM TRANSITION TL-3 MASH COMPLIANT</b>		
<b>GF (31) TR TL3-20</b>		
FILE: gf31tr+1320.dgn	DN: TxDOT	CK: KM
© TxDOT: NOVEMBER 2020	CONT SECT	JOB
REVISIONS	6435 38	001 IH10, etc
DIST	COUNTY	SHEET NO.
BMT	JEFFERSON, etc	48



DISCLAIMER: THE USE OF THIS STANDARD IS GOVERNED BY THE "TEXAS ENGINEERING PRACTICE ACT". NO WARRANTY OF ANY KIND IS MADE BY TXDOT FOR ANY PURPOSE WHATSOEVER. TXDOT ASSUMES NO RESPONSIBILITY FOR THE CONVERSION OF THIS STANDARD TO OTHER FORMATS OR FOR INCORRECT RESULTS OR DAMAGES RESULTING FROM ITS USE.

DATE: 2/28/2023  
 FILE: T:\BMT\AO\01 - CSJ Project Files\6435-38-001MBGF 2024\Design\GN\gf&mg.dgn

REQUIRED ALTERNATIVE FOR CONTINUOUS CURB EXTENDING PAST POST 7 (SEE SHT. 1 GENERAL NOTE 17)

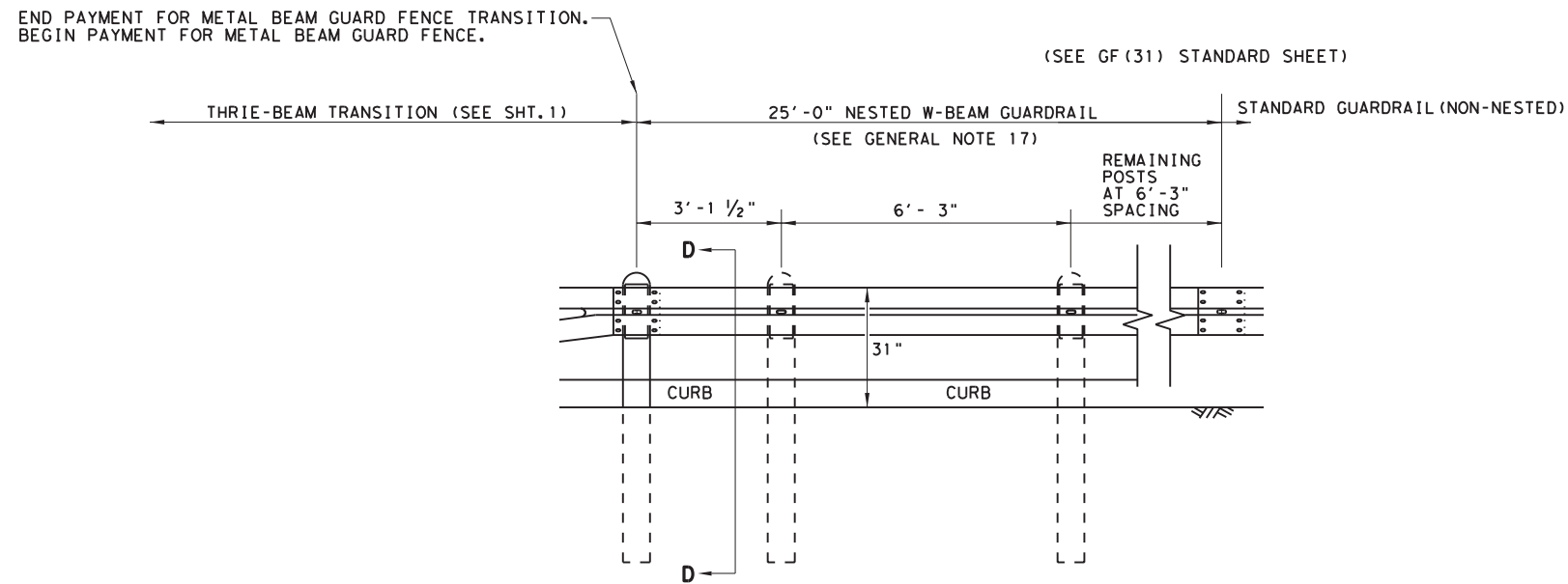

ELEVATION VIEW

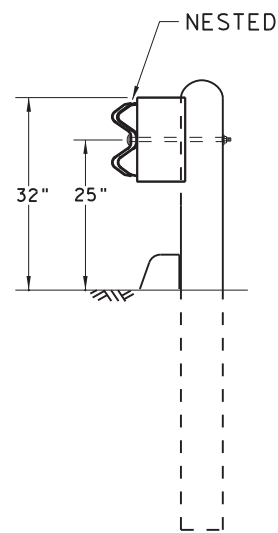

SECTION D-D

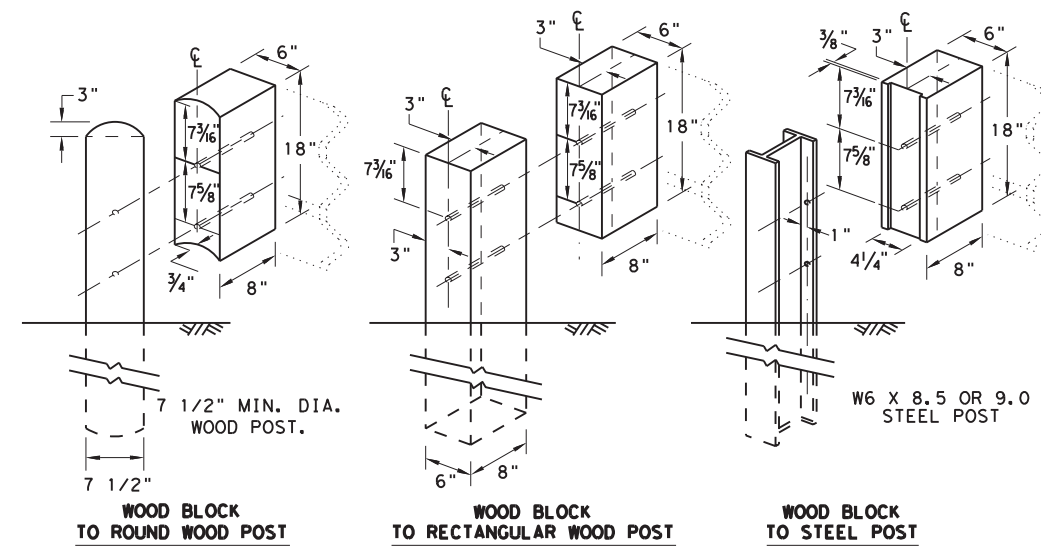

THREE BEAM TRANSITION BLOCKOUT DETAILS

HIGH-SPEED TRANSITION

SHEET 2 OF 2



METAL BEAM GUARD FENCE  
 THREE-BEAM TRANSITION  
 TL-3 MASH COMPLIANT

GF (31) TR TL3-20

FILE: gf31tr+1320.dgn	DN: TXDOT	CK: KM	DW: KM	CK: CGL/AG
©TXDOT: NOVEMBER 2020	CONT	SECT	JOB	HIGHWAY
REVISIONS	6435	38	001	IH10, etc
	DIST	COUNTY	SHEET NO.	
	BMT	JEFFERSON, etc	49	

DISCLAIMER: THE USE OF THIS STANDARD IS GOVERNED BY THE "TEXAS ENGINEERING PRACTICE ACT". NO WARRANTY OF ANY KIND IS MADE BY TXDOT FOR ANY PURPOSE WHATSOEVER. TXDOT ASSUMES NO RESPONSIBILITY FOR THE CONVERSION OF THIS STANDARD TO OTHER FORMATS OR FOR INCORRECT RESULTS OR DAMAGES RESULTING FROM ITS USE.

DATE: 2/28/2023  
 FILE: T:\BMT\AO\01 - CSJ Project Files\6435-38-001MBGF 2024\Design\GN\gf&mg.dgn

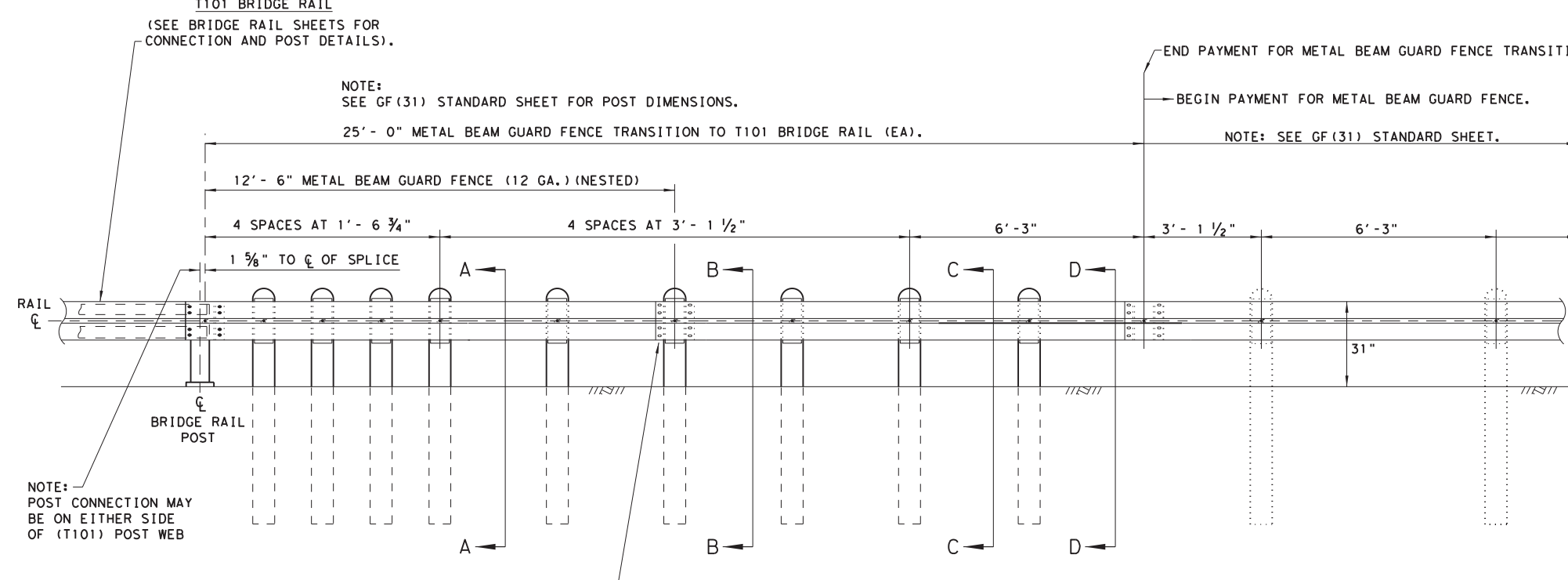
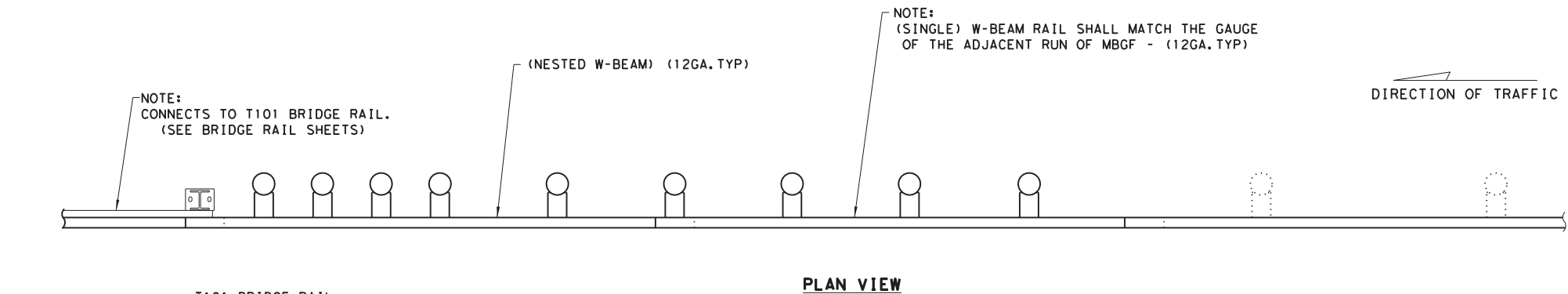

(8) 5/8" DIA. X 2" GUARDRAIL SPLICE BOLTS (FBB02)  
 WITH 5/8" GUARDRAIL NUTS (ASTM A563)  
 (SEE GENERAL NOTE 3)

**GENERAL NOTES**

1. THE TYPE OF POST (ROUND WOOD POST, RECTANGULAR WOOD POST, OR STEEL POST) WILL BE AS SHOWN IN THE PLANS. THE EXACT POSITION OF MBGF SHALL BE SHOWN IN THE PLANS OR AS DIRECTED BY THE ENGINEER. STEEL POSTS TO BE GALVANIZED IN ACCORDANCE WITH ITEM 445, "GALVANIZING."
2. RAIL ELEMENT SHALL MEET THE REQUIREMENTS OF ITEM 540, "METAL BEAM GUARD FENCE" EXCEPT AS MODIFIED IN THE PLANS. THE CONTRACTOR MAY FURNISH RAIL ELEMENTS OF 25'-0", OR 12'-6" (NOM.) LENGTHS. RAIL ELEMENTS MAY HAVE SLOTTED HOLES AT 3'-1 1/2" C-C OR 6'-3" C-C. A SPECIAL LENGTH OF RAIL MAY BE MANUFACTURED TO ACCOMMODATE THE TRANSITION SECTIONS OF GUARDRAIL.
3. BUTTON HEAD "POST" BOLTS (ASTM A307 GR. A) SHALL BE OF SUFFICIENT LENGTH TO EXTEND THROUGH THE FULL THICKNESS OF THE NUT (ASTM A563) AND 5/8" ROUND WASHER (ASTM F436) AND NOT MORE THAN 1" BEYOND IT. BUTTON HEAD "SPLICE" BOLTS (ASTM A307) ARE 5/8" X 1-1/4" WITH 5/8" NUTS (ASTM A563).
4. FITTINGS (BOLTS, NUTS, AND WASHERS) SHALL BE GALVANIZED IN ACCORDANCE WITH ITEM 445, "GALVANIZING." FITTINGS SHALL BE SUBSIDIARY TO THE BID ITEM REQUIRING CONSTRUCTION OF THE TRANSITION.
5. CROWN SHALL BE WIDENED TO ACCOMMODATE THE METAL BEAM GUARD FENCE.
6. WHERE SOLID ROCK IS ENCOUNTERED, CONTACT THE DESIGN DIVISION FOR ADDITIONAL GUIDANCE. (512) 416-2678
7. POSTS SHALL NOT BE SET IN CONCRETE.
8. UNLESS OTHERWISE SHOWN IN THE PLANS, A COMPOSITE MATERIAL BLOCK THAT MEETS THE REQUIREMENTS OF DMS-7210, "COMPOSITE MATERIAL POSTS AND BLOCKS FOR METAL BEAM GUARD FENCE" MAY BE SUBSTITUTED FOR BLOCKS OF SIMILAR DIMENSIONS. THE CONSTRUCTION DIVISION, TXDOT MAINTAINS A MATERIAL PRODUCER LIST (MPL) FOR PRODUCERS OF MATERIALS CONFORMING TO DMS-7210. ONLY PRODUCERS ON THE MPL MAY FURNISH COMPOSITE MATERIAL BLOCKS.
9. REFER TO STANDARD GF(31) AND APPLICABLE BRIDGE RAILING STANDARD FOR ADDITIONAL DETAILS.

\* "WOOD" INDICATES DIMENSIONS FOR BOTH ROUND AND RECTANGULAR WOOD POST SYSTEMS.

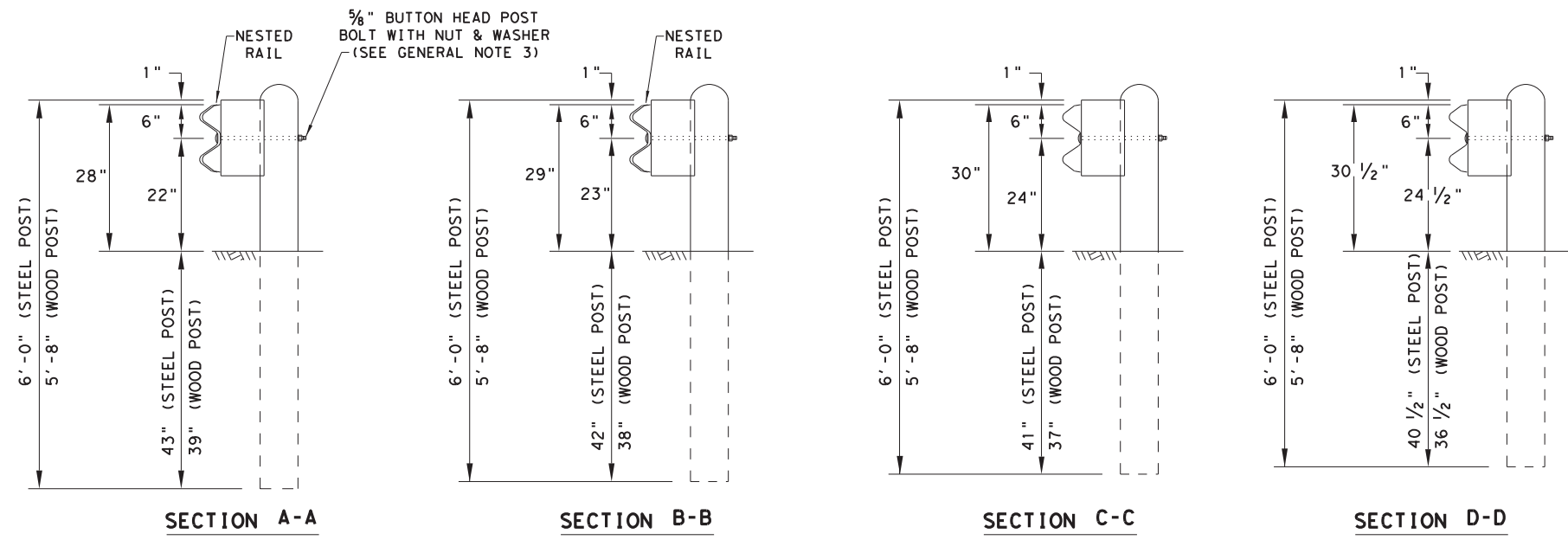

				Design Division Standard
<b>METAL BEAM GUARD FENCE                  TRANSITION                  (T101)                  GF(31)T101-19</b>				
FILE: gf31t10119	DN: TXDOT	CK: KM	DW: VP	CK: CGL/AG
© TXDOT: NOVEMBER 2019	CONT	SECT	JOB	HIGHWAY
REVISIONS	6435	38	001	IH10, etc
	DIST	COUNTY		SHEET NO.
	BMT	JEFFERSON, etc		50

DISCLAIMER: THIS STANDARD IS GOVERNED BY THE "TEXAS ENGINEERING PRACTICE ACT". NO WARRANTY OF ANY KIND IS MADE BY TXDOT FOR ANY PURPOSE WHATSOEVER. TXDOT ASSUMES NO RESPONSIBILITY FOR THE CONVERSION OF THIS STANDARD TO OTHER FORMATS OR FOR INCORRECT RESULTS OR DAMAGES RESULTING FROM ITS USE.

DATE: 2/28/2023  
 FILE: T:\BMT\AO\01 - CSJ Project Files\6435-38-001MBGF 2024\Design\DGN\gf&mg.dgn

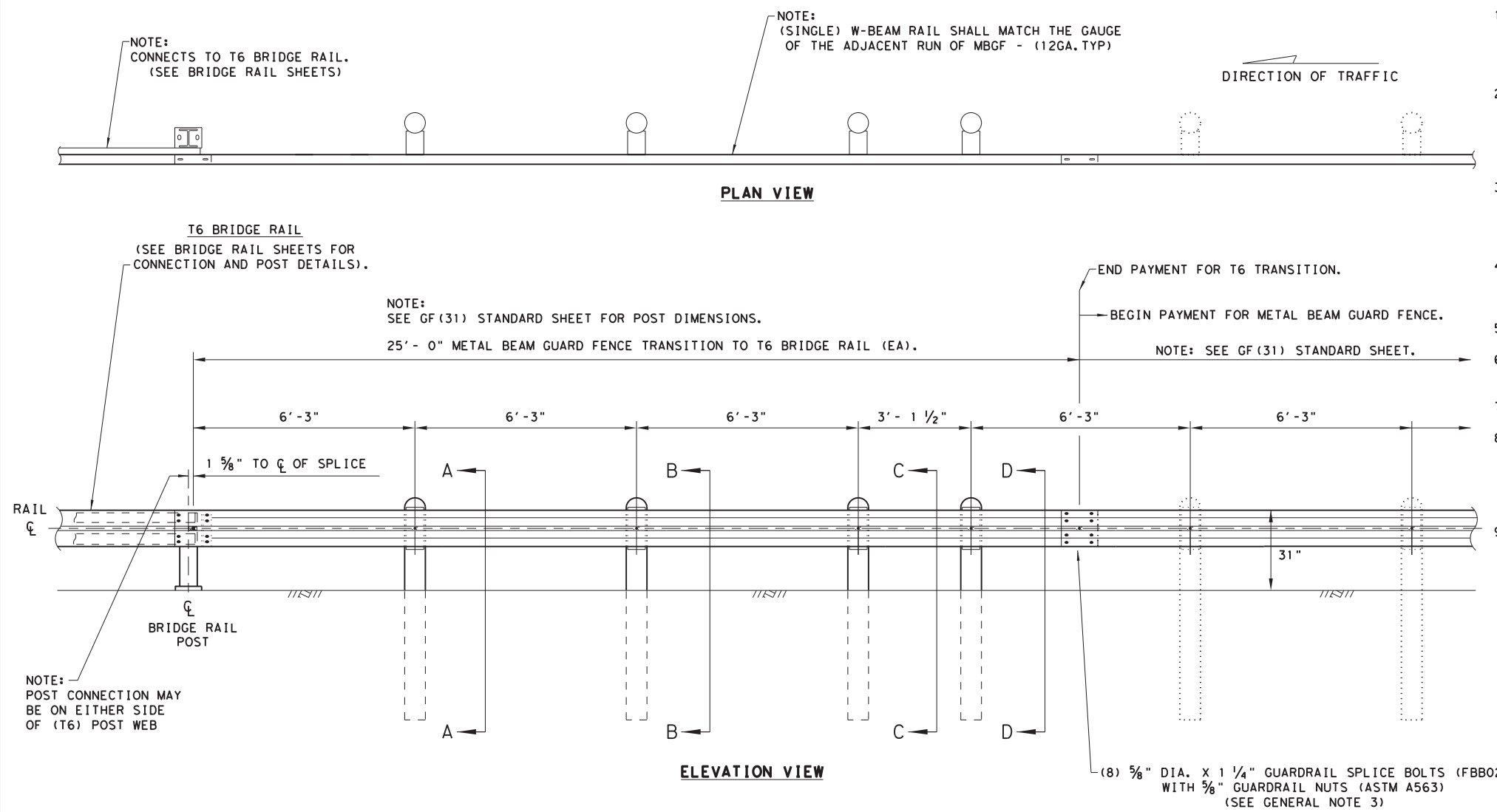

- GENERAL NOTES**
1. THE TYPE OF POST (ROUND WOOD POST, OR STEEL POST) WILL BE AS SHOWN IN THE PLANS. THE EXACT POSITION OF MBGF SHALL BE SHOWN IN THE PLANS OR AS DIRECTED BY THE ENGINEER. STEEL POSTS TO BE GALVANIZED IN ACCORDANCE WITH ITEM 445, "GALVANIZING."
  2. RAIL ELEMENT SHALL MEET THE REQUIREMENTS OF ITEM 540, "METAL BEAM GUARD FENCE" EXCEPT AS MODIFIED IN THE PLANS. THE CONTRACTOR MAY FURNISH RAIL ELEMENTS OF 25'-0", OR 12'-6" (NOM.) LENGTHS. RAIL ELEMENTS MAY HAVE SLOTTED HOLES AT 3'-1 1/2" C-C OR 6'-3" C-C. A SPECIAL LENGTH OF RAIL MAY BE MANUFACTURED TO ACCOMMODATE THE TRANSITION SECTIONS OF GUARDRAIL.
  3. BUTTON HEAD "POST" BOLTS (ASTM A307 GR.A) SHALL BE OF SUFFICIENT LENGTH TO EXTEND THROUGH THE FULL THICKNESS OF THE NUT (ASTM A563) AND 5/8" ROUND WASHER (ASTM F436) AND NOT MORE THAN 1" BEYOND IT. BUTTON HEAD "SPLICE" BOLTS (ASTM A307) ARE 5/8" X 1-1/4" WITH 5/8" NUTS (ASTM A563).
  4. FITTINGS (BOLTS, NUTS, AND WASHERS) SHALL BE GALVANIZED IN ACCORDANCE WITH ITEM 445, "GALVANIZING." FITTINGS SHALL BE SUBSIDIARY TO THE BID ITEM REQUIRING CONSTRUCTION OF THE TRANSITION.
  5. CROWN SHALL BE WIDENED TO ACCOMMODATE THE METAL BEAM GUARD FENCE.
  6. WHERE SOLID ROCK IS ENCOUNTERED. CONTACT THE DESIGN DIVISION FOR ADDITIONAL GUIDANCE. (512) 416-2678
  7. POSTS SHALL NOT BE SET IN CONCRETE.
  8. UNLESS OTHERWISE SHOWN IN THE PLANS, A COMPOSITE MATERIAL BLOCK THAT MEETS THE REQUIREMENTS OF DMS-7210, "COMPOSITE MATERIAL POSTS AND BLOCKS FOR METAL BEAM GUARD FENCE" MAY BE SUBSTITUTED FOR BLOCKS OF SIMILAR DIMENSIONS. THE CONSTRUCTION DIVISION, TXDOT MAINTAINS A MATERIAL PRODUCER LIST (MPL) FOR PRODUCERS OF MATERIALS CONFORMING TO DMS-7210. ONLY PRODUCERS ON THE MPL MAY FURNISH COMPOSITE MATERIAL BLOCKS.
  9. REFER TO STANDARD GF (31) & APPLICABLE BRIDGE RAILING STANDARD FOR ADDITIONAL DETAILS.

\* "WOOD" INDICATES DIMENSIONS FOR BOTH ROUND AND RECTANGULAR WOOD POST SYSTEMS.

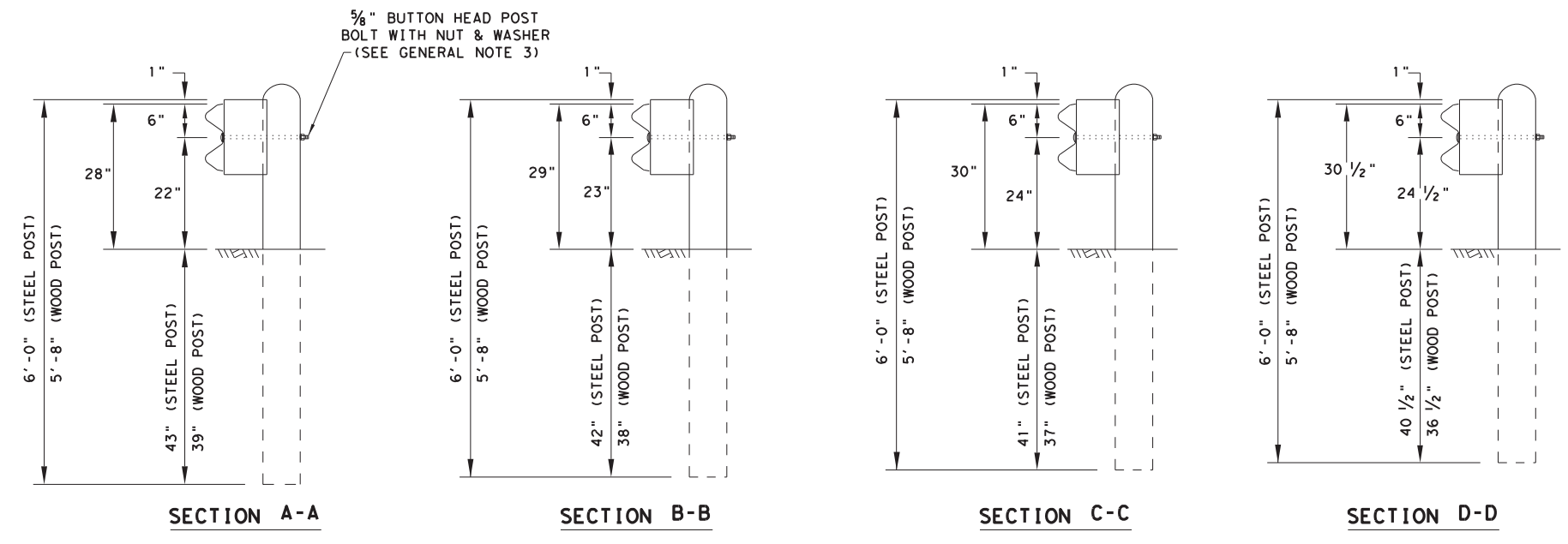

Texas Department of Transportation				Design Division Standard	
<b>METAL BEAM GUARD FENCE TRANSITION (T6)</b>					
<b>GF (31) T6-19</b>					
FILE: gf31t619.dgn	DN: TXDOT	CK: KM	DW: VP	CK: CGL/AG	
© TXDOT: NOVEMBER 2019	CONT	SECT	JOB	HIGHWAY	
REVISIONS	6435	38	001	IH10, etc	
	DIST	COUNTY		SHEET NO.	
	BMT	JEFFERSON, etc		51	

DISCLAIMER: THE USE OF THIS STANDARD IS GOVERNED BY THE "TEXAS ENGINEERING PRACTICE ACT". NO WARRANTY OF ANY KIND IS MADE BY TXDOT FOR ANY PURPOSE WHATSOEVER. TXDOT ASSUMES NO RESPONSIBILITY FOR THE CONVERSION OF THIS STANDARD TO OTHER FORMATS OR FOR INCORRECT RESULTS OR DAMAGES RESULTING FROM ITS USE.

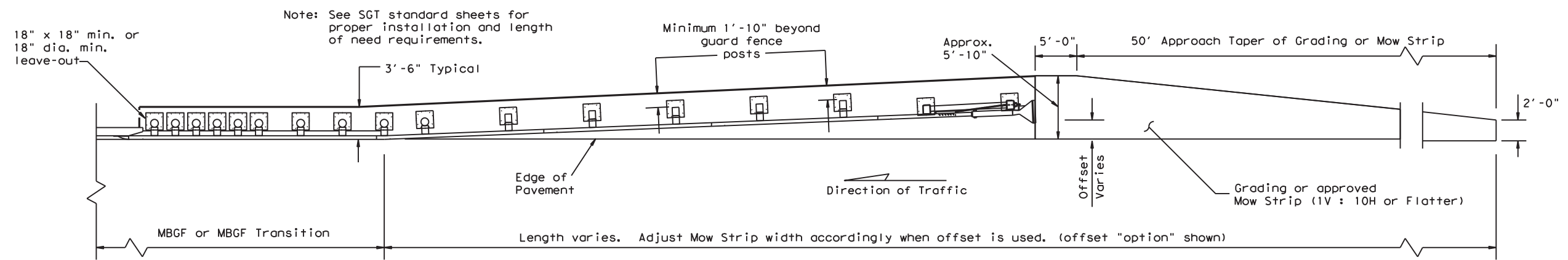

Note: See SGT standard sheets for proper installation and length of need requirements.

**GRADING AND MOW STRIP AT GUARDRAIL END TREATMENTS**

Note: Site Condition(s)  
 Site conditions may exist where grading is required for the proper installation of metal guard fence and end treatments.  
 Approach grading or mow strip may be decreased or eliminated, as directed by the Engineer.

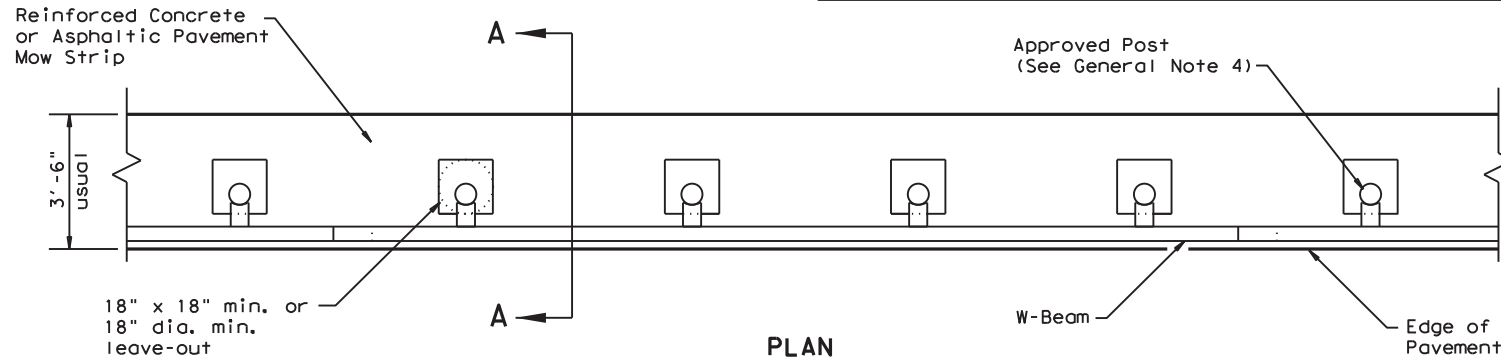

**PLAN**

GF(31) shown with Mow Strip  
 (See GF(31) standard sheet for proper installation)

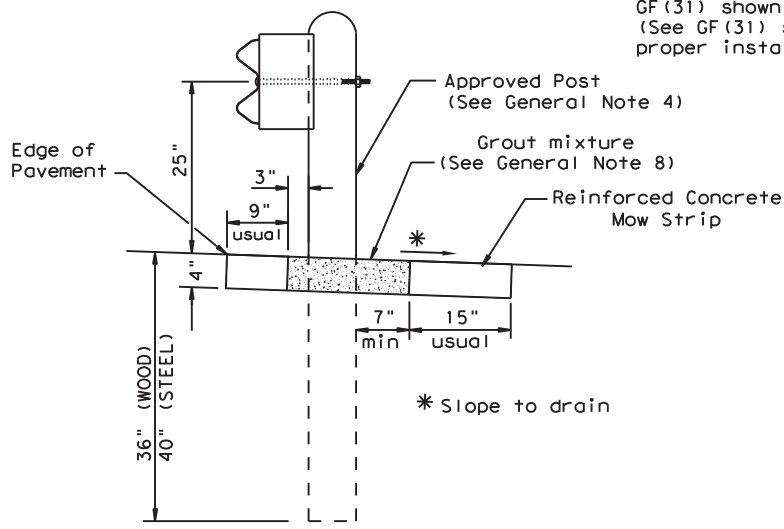

**SECTION A-A**

Typical

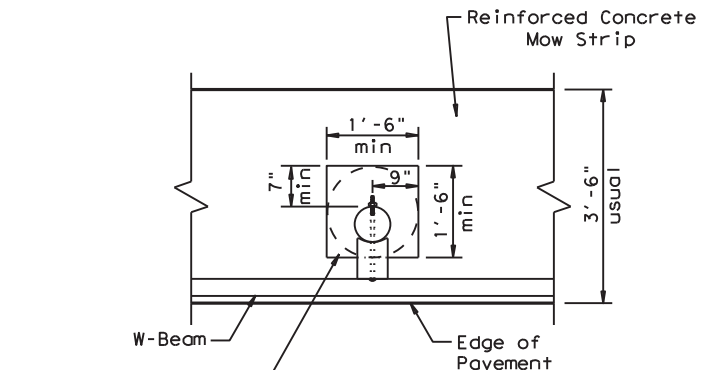

**MOW STRIP DETAIL**

Reinforced Concrete Mow Strip with 18\"/>

- GENERAL NOTES**
1. This mow strip design is for use with metal beam guard fence, guard fence transitions, and guard fence end treatments. See applicable GF(31) MBGF or GF(31) Transition Standard sheet for additional information.
  2. Mow strips shall be reinforced concrete with (wire mesh or synthetic fiber), as shown on the plans and will be paid for under the pertinent bid item. Reinforced concrete shall be placed in accordance with Item 432, "Riprap." The use of the synthetic fiber in lieu of steel reinforcing is acceptable, provided the fiber producer is on the Department Material Producer List (MPL), maintained by TxDOT, Construction Division.
  3. The leave-out behind the post shall be a minimum of 7".
  4. Only steel (W6 x 8.5 or W6 x 9.0), or 7 1/2" Dia. round wood posts are acceptable for use in the mow strip. See GF(31) Standard for additional details.
  5. Other curb placement options may be used. Curbs are not considered part of the mow strip and will be paid for under other pertinent bid item.
  6. Thickness of the mow strip will be 4".
  7. The limits of payment for reinforced concrete will include leave-outs for the posts.
  8. The leave-outs shall be filled with a Grout mixture consisting of: 2719 pounds sand, 188 pounds Type 1 or II cement, and 550 pounds of water per cubic yard, with a 28-day compressive strength of approximately 230 psi or less. Provide grout with a consistency that will flow into and completely fill all voids. Due to auger size, larger leave-out dimensions are acceptable from both an impact performance and maintenance repair standpoint (Suggested Maximum leave-out of 20"). Payment for furnishing and placing the grout mixture will be subsidiary to the pay item of riprap mow strip.

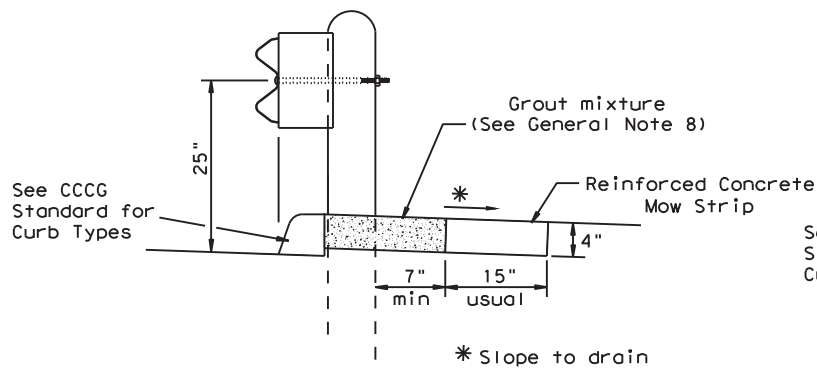

**CURB OPTION (1)**

This option will increase the post embedment throughout the system.

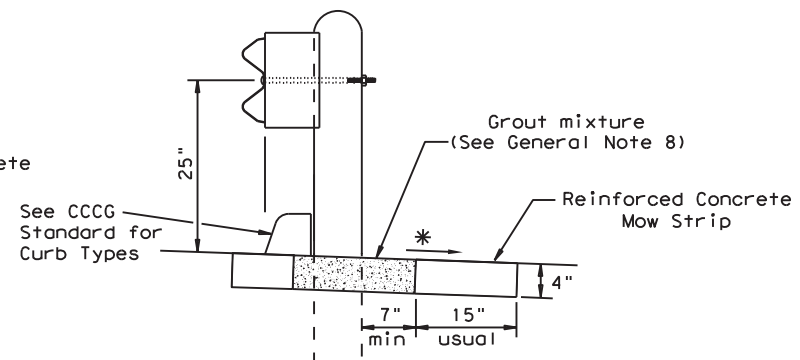

**CURB OPTION (2)**

Curb shown on top of mow strip

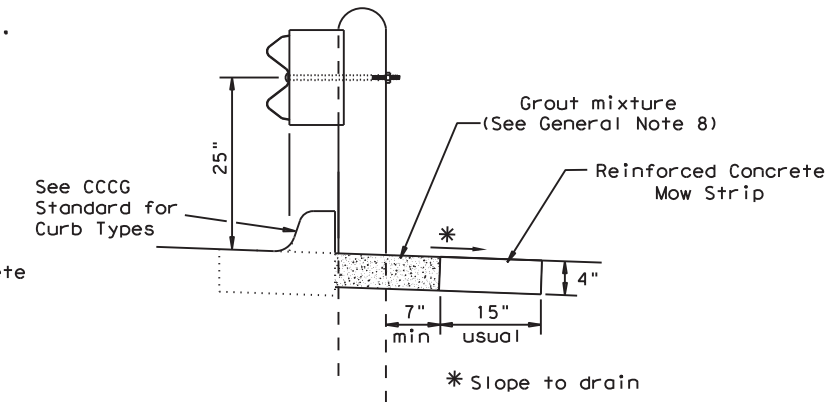

**CURB OPTION (3)**

		Design Division Standard	
<b>METAL BEAM GUARD FENCE (MOW STRIP)</b> <b>TL-3 MASH COMPLIANT</b> <b>GF(31)MS-19</b>			
FILE: gf31ms19.dgn	DN: TxDOT	CK: KM	DW: VP
© TXDOT: NOVEMBER 2019	CONT	SECT	JOB
REVISIONS	<b>6435 38</b>	<b>001</b>	<b>IH10, etc</b>
DIST	COUNTY	SHEET NO.	
<b>BMT</b>	<b>JEFFERSON, etc</b>	<b>52</b>	

DATE:  
FILE:

**GENERAL NOTES**

1. THE TYPE OF POST (ROUND WOOD POST, RECTANGULAR WOOD POST, OR STEEL POST) WILL BE AS SHOWN IN THE PLANS. THE EXACT POSITION OF MBGF SHALL BE AS SHOWN IN THE PLANS OR AS DIRECTED BY THE ENGINEER. STEEL POSTS TO BE GALVANIZED IN ACCORDANCE WITH ITEM 445, "GALVANIZING."
2. RAIL ELEMENT SHALL MEET THE REQUIREMENTS OF ITEM 540, "METAL BEAM GUARD FENCE" EXCEPT AS MODIFIED IN THE PLANS. THE CONTRACTOR MAY FURNISH RAIL ELEMENTS OF 25'-0", OR 12'-6" (NOM.) LENGTHS. RAIL ELEMENTS MAY HAVE SLOTTED HOLES AT 3'-1" C-C OR 6'-3" C-C. A SPECIAL LENGTH OF RAIL MAY BE MANUFACTURED TO ACCOMMODATE THE TRANSITION SECTIONS OF GUARDRAIL.
3. BUTTON HEAD "POST" BOLTS (ASTM A307) SHALL BE OF SUFFICIENT LENGTH TO EXTEND THROUGH THE FULL THICKNESS OF THE NUT (ASTM A563) AND ?" ROUND WASHER (ASTM F436) AND NOT MORE THAN 1" BEYOND IT. BUTTON HEAD "SPLICE" BOLTS (ASTM A307) ARE ?" X 1- ?" WITH ?" NUTS (ASTM A563).
4. FITTINGS (BOLTS, NUTS, AND WASHERS) SHALL BE GALVANIZED IN ACCORDANCE WITH ITEM 445, "GALVANIZING." FITTINGS SHALL BE SUBSIDIARY TO THE BID ITEM REQUIRING CONSTRUCTION OF THE TRANSITION.
5. CROWN SHALL BE WIDENED TO ACCOMMODATE THE METAL BEAM GUARD FENCE.
6. THE LATERAL APPROACH TO THE GUARD FENCE, SHALL HAVE A MAXIMUM SLOPE OF 1V:10H.
7. IF SHOWN ELSEWHERE IN THE PLANS OR AS DIRECTED BY THE ENGINEER, THE GUARD FENCE MAY BE FLARED AT A RATE OF 25:1 OR FLATTER.
8. APPLICATIONS IN SOLID ROCK ARE ONLY ALLOWED WITH STEEL POSTS. SEE GF(31) STANDARD FOR INSTALLATION GUIDANCE.
9. POSTS SHALL NOT BE SET IN CONCRETE.
10. UNLESS OTHERWISE SHOWN IN THE PLANS, A COMPOSITE MATERIAL BLOCK THAT MEETS THE REQUIREMENTS OF DMS-7210, "COMPOSITE MATERIAL POSTS AND BLOCKS FOR METAL BEAM GUARD FENCE" MAY BE SUBSTITUTED FOR BLOCKS OF SIMILAR DIMENSIONS. THE CONSTRUCTION DIVISION, TXDOT MAINTAINS A MATERIAL PRODUCER LIST (MPL) FOR PRODUCERS OF MATERIALS CONFORMING TO DMS-7210. ONLY PRODUCERS ON THE MPL MAY FURNISH COMPOSITE MATERIAL BLOCKS.
11. REFER TO STANDARD GF(31) FOR ADDITIONAL DETAILS.
12. RAIL HEIGHT ADJUSTMENT IS ASSESSED AT TL-3 MASH COMPLIANT FOR STEEL POST HEIGHT TRANSITION TO 28" STEEL POST GUARDRAIL.

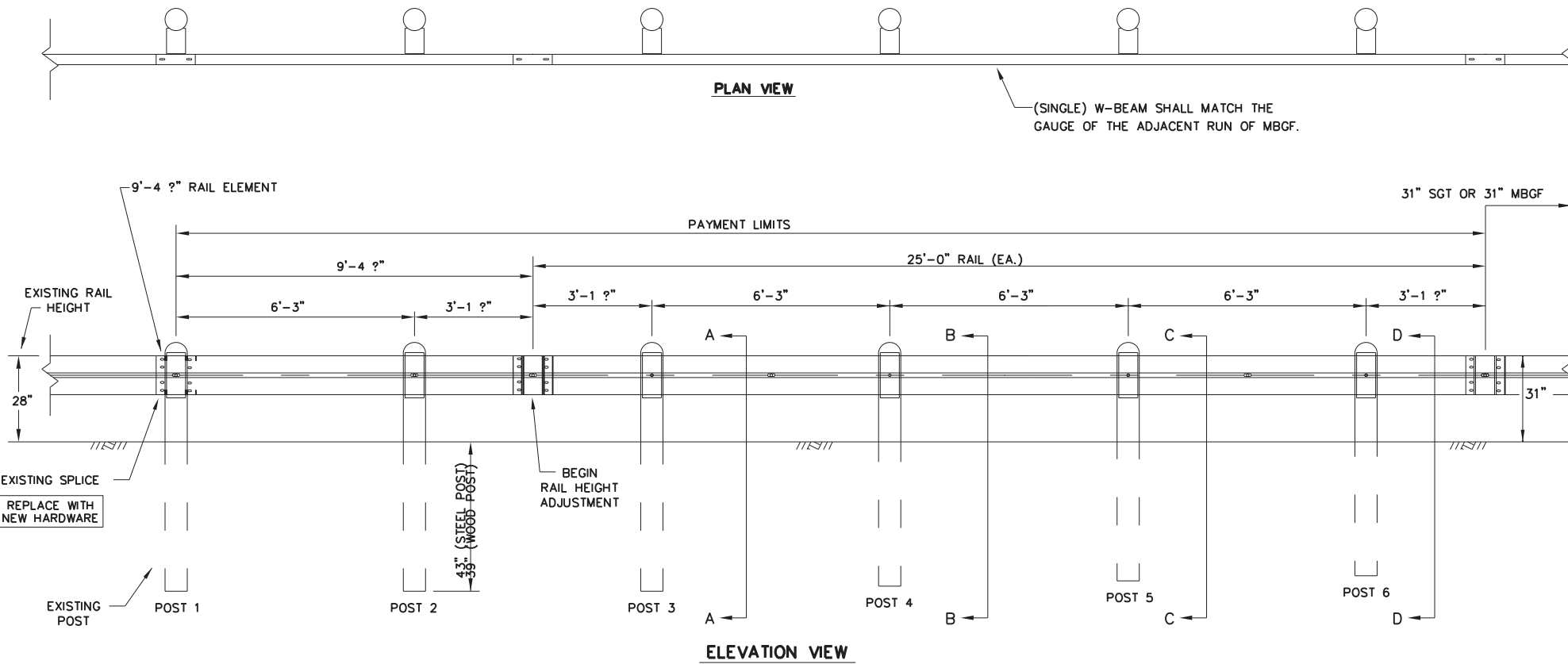

\* "WOOD" INDICATES DIMENSIONS FOR BOTH ROUND AND RECTANGULAR WOOD POST SYSTEMS.

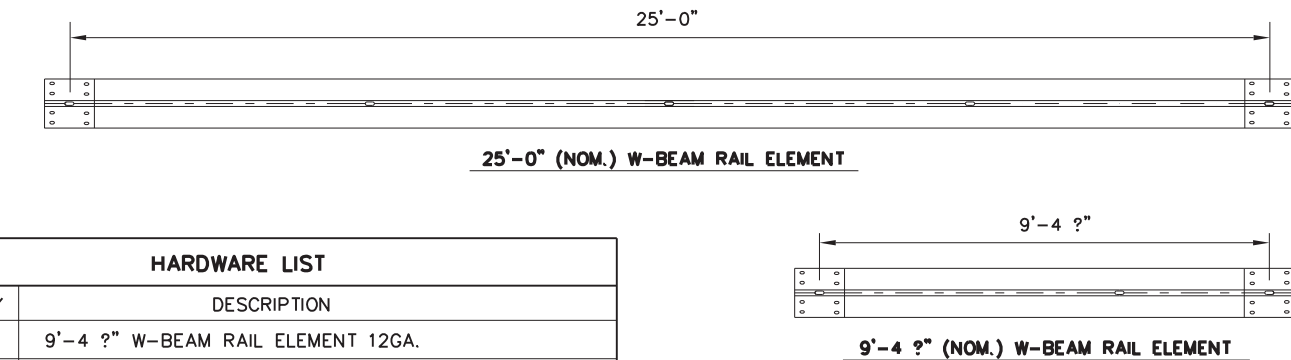
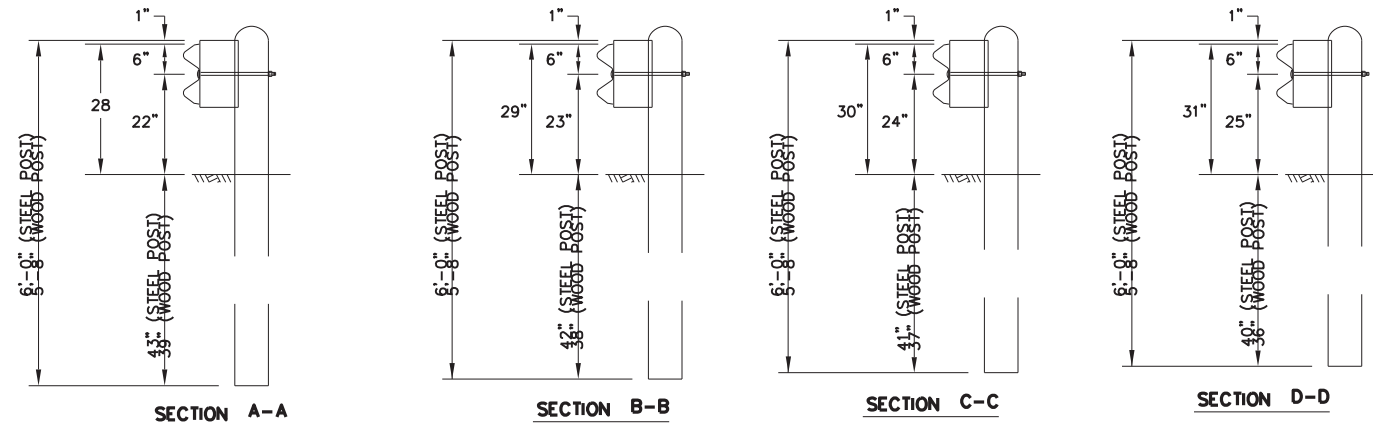

HARDWARE LIST	
QTY	DESCRIPTION
1	9'-4" W-BEAM RAIL ELEMENT 12GA.
1	25'-0" W-BEAM RAIL ELEMENT 12GA. (TYP)
6	7 ?" DIA X 6'-0" DOMED ROUND WOOD POSTS (TYP)
6	6" X 8" X 68" RECTANGULAR WOOD POSTS (TYP)
6	W6 X 8.5 OR W6 X 9 X 72" STEEL POSTS (TYP)
6	6" X 8" X 14" WOOD BLOCKS OR COMPOSITE (TYP)
6	? X 18" GUARDRAIL BOLTS WITH NUTS (FBBO4)
6	? ROUND WASHERS (ASTM F436)(FWC16a)
6	? X 10" GUARDRAIL BOLTS WITH NUTS (FBBO3)
24	? X 1- ?" GUARDRAIL SPLICE BOLTS WITH DOUBLE RECESSED NUTS (ASTM A563) (FBBO1)

POST AND BLOCK-OUT TYPES AVAILABLE

FOR WOOD POST

FOR STEEL POST

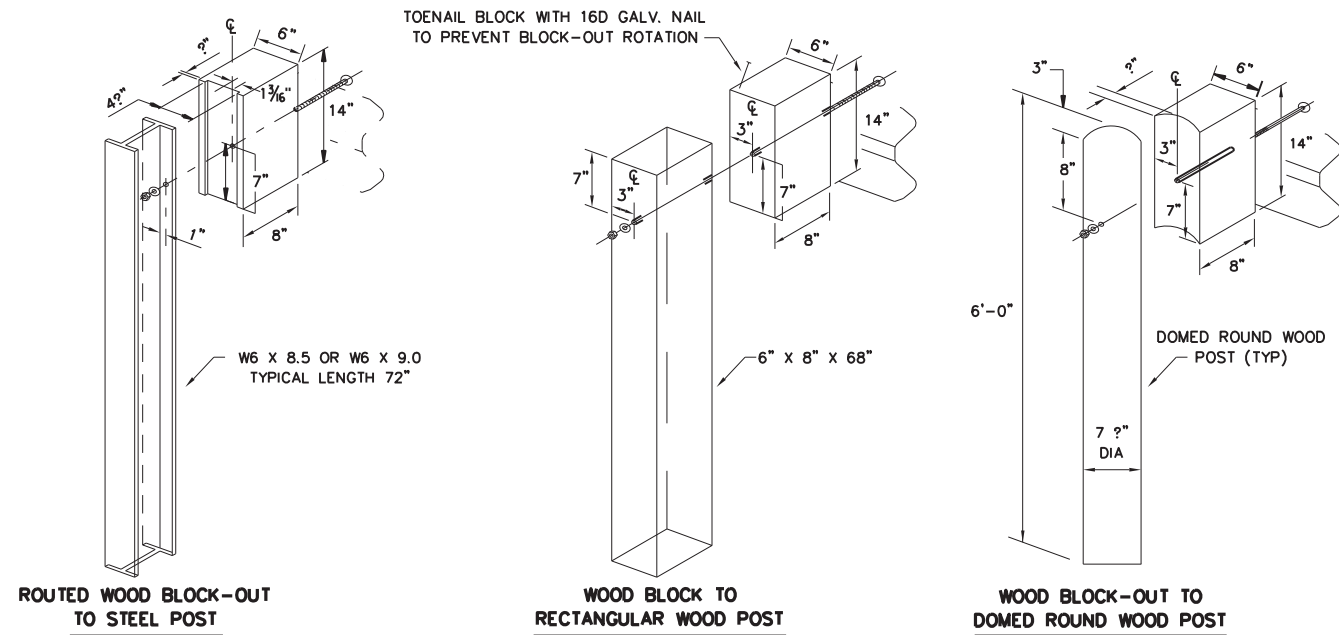

NOTE: HARDWARE SHALL MEET THE FOLLOWING REQUIREMENTS.  
 GUARDRAIL POST BOLTS (ASTM A307 GR.A)  
 GUARDRAIL ROUND WASHERS (ASTM F436)  
 GUARDRAIL DOUBLE RECESSED NUTS (ASTM A563)  
 GUARDRAIL SPLICE BOLTS (ASTM A307 GR.A)  
 GUARDRAIL SPLICE NUTS (ASTM A563)

**Texas Department of Transportation**  
 Design Division Standard

**METAL BEAM GUARD FENCE  
 RAIL HEIGHT ADJUSTMENT  
 (28" TO 31")  
 TL-3 MASH COMPLIANT  
 RAIL-ADJ(A)-19**

FILE: railadj19	DN: TxDOT	CK: KM	DW: VP	CK: CGL/AG
©TxDOT: NOVEMBER 2019	CONT	SECT	JOB	HIGHWAY
REVISIONS	6435	38	001	IH10, etc
DIST	COUNTY		SHEET NO.	
BMT	JEFFERSON, etc		53	

DISCLAIMER: THIS STANDARD IS GOVERNED BY THE "TEXAS ENGINEERING PRACTICE ACT". NO WARRANTY OF ANY KIND IS MADE BY TXDOT FOR ANY PURPOSE WHATSOEVER. TXDOT ASSUMES NO RESPONSIBILITY FOR THE CONVERSION OF THIS STANDARD TO OTHER FORMATS OR FOR INCORRECT RESULTS OR DAMAGES RESULTING FROM ITS USE.

**GENERAL NOTES**

1. THE TYPE OF POST (ROUND WOOD POST, RECTANGULAR WOOD POST, OR STEEL POST) WILL BE AS SHOWN IN THE PLANS. THE EXACT POSITION OF MBGF SHALL BE AS SHOWN IN THE PLANS OR AS DIRECTED BY THE ENGINEER. STEEL POSTS TO BE GALVANIZED IN ACCORDANCE WITH ITEM 445, "GALVANIZING."
2. RAIL ELEMENT SHALL MEET THE REQUIREMENTS OF ITEM 540, "METAL BEAM GUARD FENCE" EXCEPT AS MODIFIED IN THE PLANS. THE CONTRACTOR MAY FURNISH RAIL ELEMENTS OF 25'-0", OR 12'-6" (NOM.) LENGTHS. RAIL ELEMENTS MAY HAVE SLOTTED HOLES AT 3'-1 1/2" C-C OR 6'-3" C-C. A SPECIAL LENGTH OF RAIL MAY BE MANUFACTURED TO ACCOMMODATE THE TRANSITION SECTIONS OF GUARDRAIL.
3. BUTTON HEAD "POST" BOLTS (ASTM A307) SHALL BE OF SUFFICIENT LENGTH TO EXTEND THROUGH THE FULL THICKNESS OF THE NUT (ASTM A563) AND 5/8" ROUND WASHER (ASTM F436) AND NOT MORE THAN 1" BEYOND IT. BUTTON HEAD "SPLICE" BOLTS (ASTM A307) ARE 5/8" X 1-1/4" WITH 5/8" NUTS (ASTM A563).
4. FITTINGS (BOLTS, NUTS, AND WASHERS) SHALL BE GALVANIZED IN ACCORDANCE WITH ITEM 445, "GALVANIZING." FITTINGS SHALL BE SUBSIDIARY TO THE BID ITEM REQUIRING CONSTRUCTION OF THE TRANSITION.
5. CROWN SHALL BE WIDENED TO ACCOMMODATE THE METAL BEAM GUARD FENCE.
6. THE LATERAL APPROACH TO THE GUARD FENCE, SHALL HAVE A MAXIMUM SLOPE OF 1V:10H.
7. IF SHOWN ELSEWHERE IN THE PLANS OR AS DIRECTED BY THE ENGINEER, THE GUARD FENCE MAY BE FLARED AT A RATE OF 25:1 OR FLATTER.
8. APPLICATIONS IN SOLID ROCK ARE ONLY ALLOWED WITH STEEL POSTS. SEE GF(31) STANDARD FOR INSTALLATION GUIDANCE.
9. POSTS SHALL NOT BE SET IN CONCRETE.
10. UNLESS OTHERWISE SHOWN IN THE PLANS, A COMPOSITE MATERIAL BLOCK THAT MEETS THE REQUIREMENTS OF DMS-7210, "COMPOSITE MATERIAL POSTS AND BLOCKS FOR METAL BEAM GUARD FENCE" MAY BE SUBSTITUTED FOR BLOCKS OF SIMILAR DIMENSIONS. THE CONSTRUCTION DIVISION, TXDOT MAINTAINS A MATERIAL PRODUCER LIST (MPL) FOR PRODUCERS OF MATERIALS CONFORMING TO DMS-7210. ONLY PRODUCERS ON THE MPL MAY FURNISH COMPOSITE MATERIAL BLOCKS.
11. REFER TO STANDARD GF(31) FOR ADDITIONAL DETAILS.
12. RAIL HEIGHT ADJUSTMENT IS ASSESSED AT TL-3 MASH COMPLIANT FOR STEEL POST HEIGHT TRANSITION TO 28" STEEL POST GUARDRAIL.

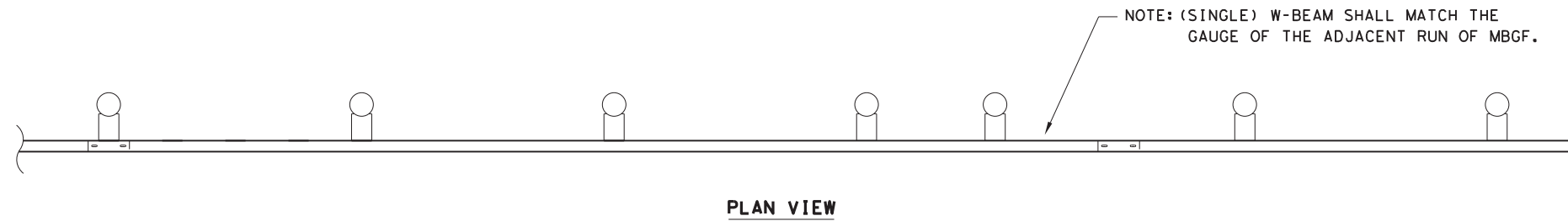

NOTE: (SINGLE) W-BEAM SHALL MATCH THE GAUGE OF THE ADJACENT RUN OF MBGF.

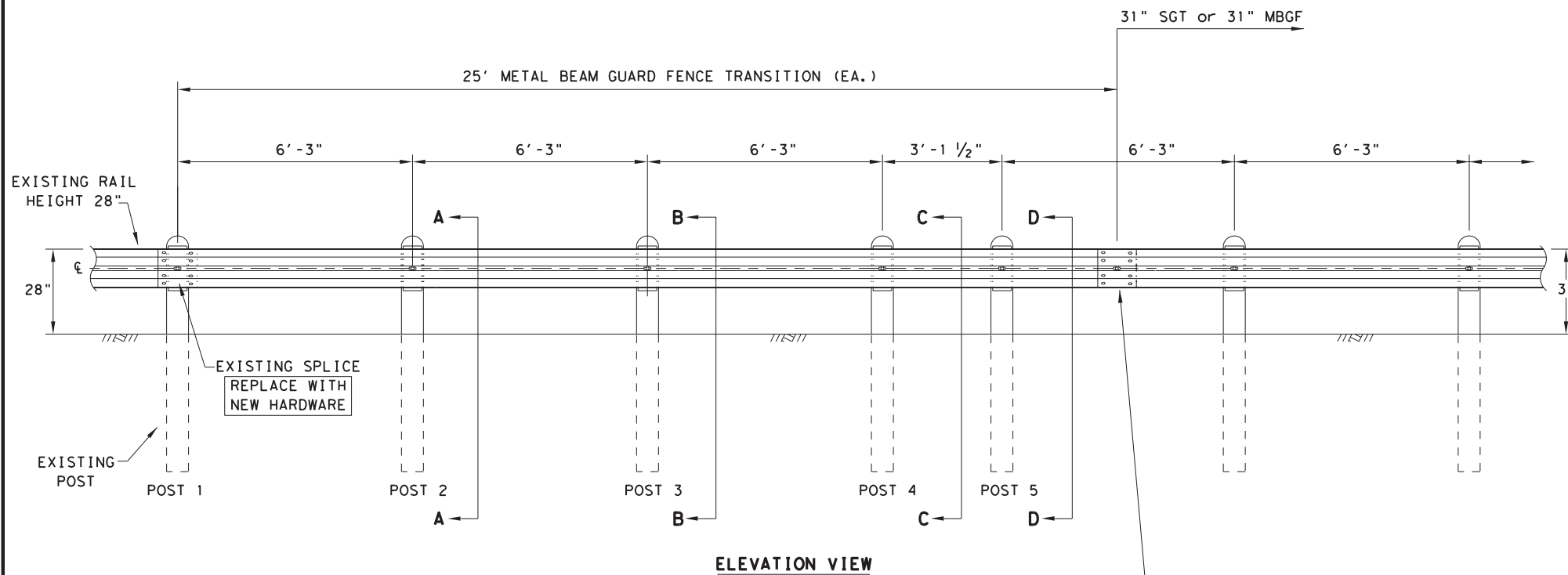

**ELEVATION VIEW**

\* "WOOD" INDICATES DIMENSIONS FOR BOTH ROUND AND RECTANGULAR WOOD POST SYSTEMS.

(8) 5/8" DIA. X 1 1/4" GUARDRAIL SPLICE BOLTS WITH 5/8" NUTS (ASTM A563). (SEE GENERAL NOTE 3).

POST AND BLOCK-OUT TYPES AVAILABLE

FOR WOOD POST

FOR STEEL POST

HARDWARE LIST	
QTY	DESCRIPTION
1	25'-0" W-BEAM RAIL ELEMENT 12GA. (TYP)
5	7 1/2" DIA X 6'-0" DOMED ROUND WOOD POSTS (TYP)
5	6" X 8" X 68" RECTANGULAR WOOD POSTS (TYP)
5	W6 X 8.5 OR W6 X 9 X 72" STEEL POSTS (TYP)
5	6" X 8" X 14" WOOD BLOCKS OR COMPOSITE (TYP)
5	5/8" X 18" GUARDRAIL BOLTS AND NUTS (FBB04)
5	5/8" ROUND WASHERS (ASTM F436) (FWC160)
5	5/8" X 10" GUARDRAIL BOLTS AND NUTS (FBB03)
16	5/8" X 1-1/4" GUARDRAIL SPLICE BOLTS WITH DOUBLE RECESSED NUTS (ASTM A563) (FBB01)

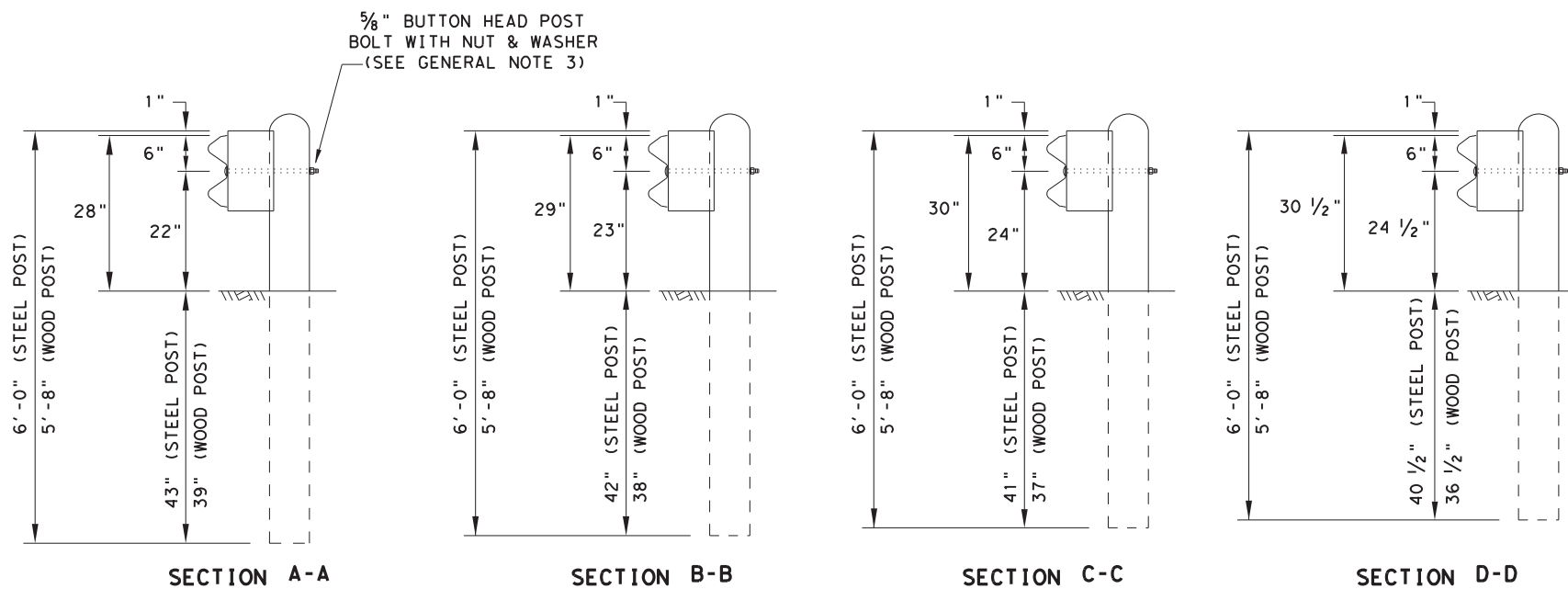

NOTE: HARDWARE SHALL MEET THE FOLLOWING REQUIREMENTS.  
 GUARDRAIL POST BOLTS (ASTM A307 GR. A)  
 GUARDRAIL ROUND WASHERS (ASTM F436)  
 GUARDRAIL DOUBLE RECESSED NUTS (ASTM A563)  
 GUARDRAIL SPLICE BOLTS (ASTM A307 GR. A)  
 GUARDRAIL SPLICE NUTS (ASTM A563)

*Design Division Standard*

## METAL BEAM GUARD FENCE RAIL HEIGHT ADJUSTMENT (28" TO 31") TL-3 MASH COMPLIANT RAIL-ADJ(B)-19

FILE: railadjb19	DN: TXDOT	CK: KM	DW: VP	CK: CGL/AG
© TXDOT: NOVEMBER 2019	CONT	SECT	JOB	HIGHWAY
REVISIONS	6435	38	001	IH10, etc
DIST	COUNTY		SHEET NO.	
BMT	JEFFERSON, etc		54	

DATE:  
FILE:

DISCLAIMER: The use of this standard is governed by the "Texas Engineering Practice Act". No warranty of any kind is made by TxDOT for any purpose whatsoever. TxDOT assumes no responsibility for the conversion of this standard to other formats or for incorrect results or damages resulting from its use.

DATE: 2/28/2023 8:52:12 AM  
 FILE: T:\BMT\AO\01 - CSJ Project Files\6435-38-001\MBGF\_2024\Design\GNG\gf&mg.dgn

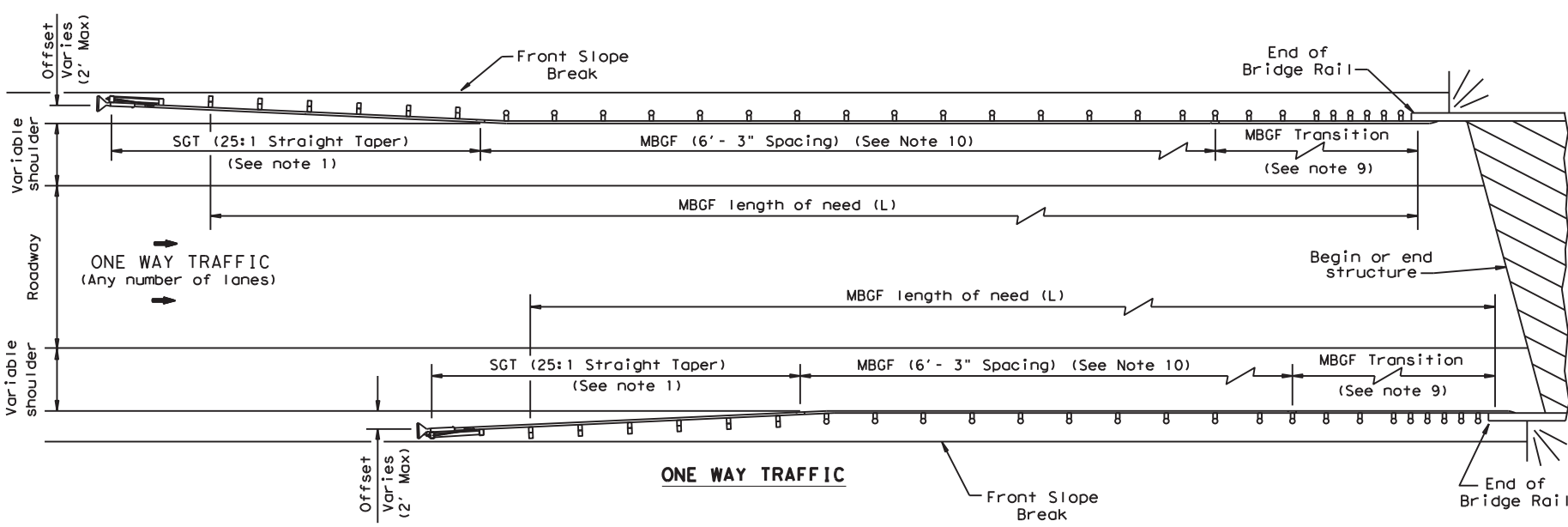
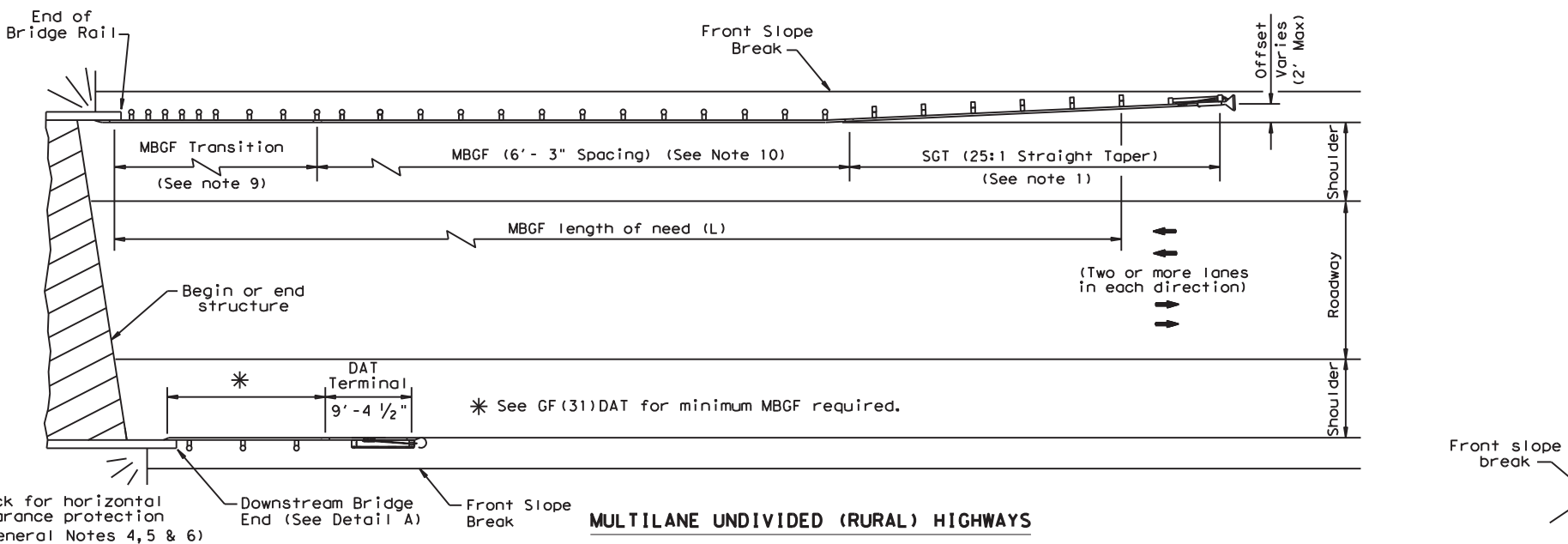
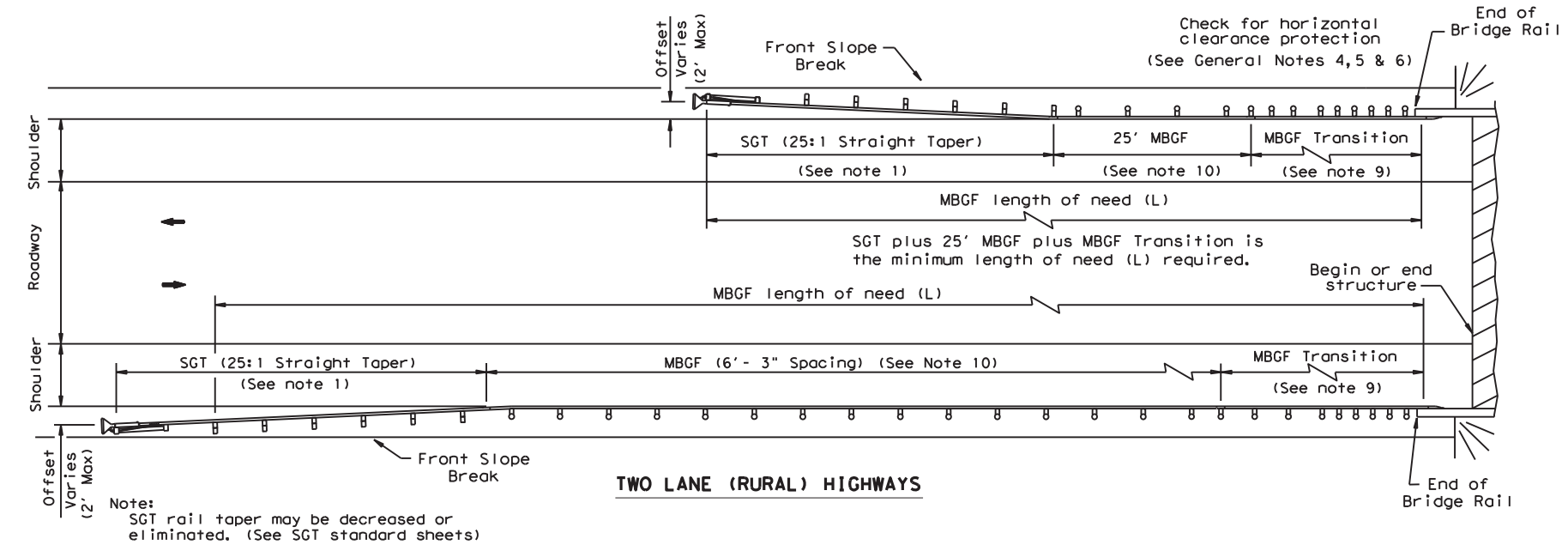

**GENERAL NOTES**

- For more detail: See GF(31), SGT( )31, GF(31)TR, and GF(31)TL2 standard sheets.
- Quantities of metal beam guard fence (MBGF) at individual bridge ends are as shown in the plans.
- Use average daily traffic (ADT) for the current year to determine MBGF length of need in accordance with the Roadway Design Manual unless otherwise specified. Where significant traffic volume growth is anticipated on low volume (0-750 ADT) highways, use length determinations for the higher volume category.
- MBGF may not be required to shield departure end of bridge unless other obstacles within the horizontal clearance limits or opposing traffic indicate a MBGF consideration.
- Downstream anchor terminals (DAT) are only for downstream end anchorage use, outside the horizontal clearance area of opposing traffic.
- Direct connection of MBGF to concrete rails are only for downstream rail connections outside the horizontal clearance area of opposing traffic. (This requires a minimum of three standard line posts plus the DAT terminal, See Detail A)
- The crown shall be widened to accommodate MBGF. Typically the "front slope" break should be 2'-0" from the back of the MBGF post. This applies to new construction on new alignment or where existing roadway cross section is to be widened to increase roadway width. This does not apply to rehabilitation work where existing roadway crown width is to be retained (See Typical Cross Section at MBGF).
- For restrictive bridge widths: The MBGF should be properly transitioned from the existing bridge rail to the adjoining MBGF (See MBGF Transition Standards). Metal beam guard fence at these bridge locations shall be flared at the rate of 25:1 or flatter, and be of the length necessary to locate the terminal end at the 2 ft. "maximum" offset from the shoulder edge in the approach direction.
- Transition length and post spacing will vary depending on the transition type. Transition type will be shown elsewhere in the plans.
- A minimum 25' length of MBGF will be required.

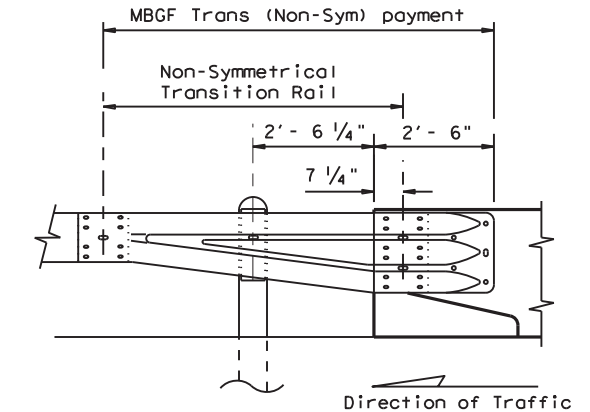
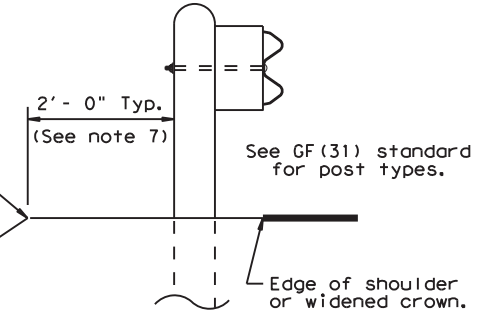

Note: All rail elements shall be lapped in the direction of adjacent traffic.

Texas Department of Transportation		Design Division Standard	
<b>BRIDGE END DETAILS</b> (METAL BEAM GUARD FENCE APPLICATIONS TO RIGID RAILS)			
<b>BED-14</b>			
FILE: bed14.dgn	DN: TxDOT	CK: AM	DW: BD/VP
© TxDOT: December 2011	CONT: 6435	SECT: 38	JOB: 001
REVISIONS	REVISED APRIL 2014	SEE (MEMO 0414)	HIGHWAY: IH10, etc
DIST: BMT	COUNTY: JEFFERSON, etc	SHEET NO. 55	

DISCLAIMER: The use of this standard is governed by the "Texas Engineering Practice Act". No warranty of any kind is made by TxDOT for any purpose whatsoever. TxDOT assumes no responsibility for the conversion of this standard to other formats or for incorrect results or damages resulting from its use.

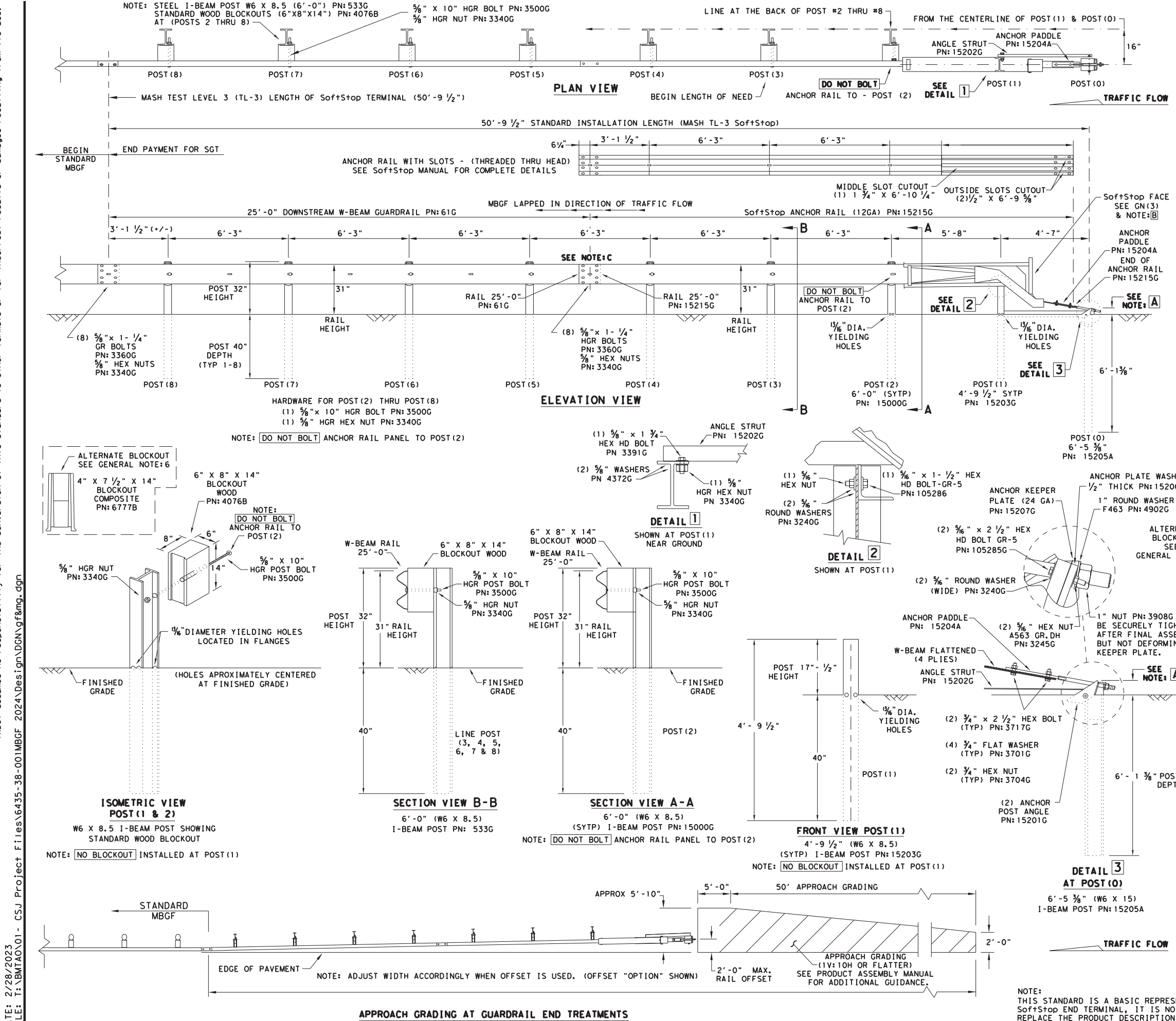

**GENERAL NOTES**

- FOR SPECIFIC INFORMATION REGARDING INSTALLATION AND TECHNICAL GUIDANCE OF THE SYSTEM, CONTACT: TRINITY HIGHWAY AT 1(888)323-6374, 2525 N. STEMMONS FREEWAY, DALLAS, TX 75207
- FOR INSTALLATION, REPAIR AND MAINTENANCE REFER TO THE SoftStop END TERMINAL, PRODUCT DESCRIPTION ASSEMBLY MANUAL. PN: 620237B
- APPLY HIGH INTENSITY REFLECTIVE SHEETING, "OBJECT MARKER" ON THE FRONT FACE OF THE DEVICE PER MANUFACTURER'S RECOMMENDATIONS. OBJECT MARKER SHALL CONFORM TO THE STANDARDS REQUIRED IN TEXAS MUTCD.
- FOR POST (LEAVE-OUT) INSTALLATION AND GUIDANCE SEE TxDOT'S LATEST ROADWAY MOW STRIP STANDARD.
- HARDWARE (BOLTS, NUTS, & WASHERS) SHALL BE GALVANIZED IN ACCORDANCE WITH ITEM 445, "GALVANIZING". FITTINGS SHALL BE SUBSIDIARY TO THE BID ITEM.
- A COMPOSITE MATERIAL BLOCKOUT THAT MEETS THE REQUIREMENTS OF DMS-7210, MAY BE SUBSTITUTED FOR BLOCKOUTS OF SIMILAR DIMENSIONS. SEE CONSTRUCTION DIVISION MATERIAL PRODUCER LIST (MPL) FOR CERTIFIED PRODUCERS.
- IF SOLID ROCK IS ENCOUNTERED SEE THE MANUFACTURER'S INSTALLATION MANUAL AND REFER TO THE LATEST ROADWAY MBGF STANDARD FOR INSTALLATION GUIDANCE.
- POSTS SHALL NOT BE SET IN CONCRETE.
- IT IS ACCEPTABLE TO INSTALL THE SoftStop IMPACT HEAD PARALLEL TO THE GRADE LINE OR WITH AN UPWARD TILT.
- DO NOT ATTACH THE SoftStop SYSTEM DIRECTLY TO A RIGID BARRIER.
- UNDER NO CIRCUMSTANCES SHALL THE GUARDRAIL WITHIN THE SoftStop SYSTEM BE CURVED.
- A FLARE RATE OF UP TO 25:1 MAY BE USED TO PREVENT THE TERMINAL HEAD FROM ENCRoaching ON THE SHOULDER. THE FLARE MAY BE DECREASED OR ELIMINATED FOR SPECIFIC INSTALLATIONS, IF DIRECTED BY THE ENGINEER.

<b>NOTE: A</b>	THE INSTALLATION HEIGHT OF FULLY ASSEMBLED ANCHOR POST WILL VARY FROM 3-3/4" MIN. TO 4" MAX. ABOVE FINISHED GRADE.
<b>NOTE: B</b>	PART PN: 5852B RIGHT-SIDE (HIGH INTENSITY REFLECTIVE SHEETING) PART PN: 5851B LEFT-SIDE (HIGH INTENSITY REFLECTIVE SHEETING)
<b>NOTE: C</b>	W-BEAM SPLICE LOCATED BETWEEN LINE POST (4) AND LINE POST (5) GUARDRAIL PANEL 25'-0" PN: 61G ANCHOR RAIL 25'-0" PN: 15215G LAP GUARDRAIL IN DIRECTION OF TRAFFIC FLOW.

PART	QTY	MAIN SYSTEM COMPONENTS
620237B	1	PRODUCT DESCRIPTION ASSEMBLY MANUAL (LATEST REV.)
15208A	1	SoftStop HEAD (SEE MANUAL FOR RIGHT-LEFT APPROACH)
15215G	1	SoftStop ANCHOR RAIL (12GA) WITH CUTOUT SLOTS
61G	1	SoftStop DOWNSTREAM W-BEAM RAIL (12GA) (25'-0")
15205A	1	POST #0 - ANCHOR POST (6'-5 3/8")
15203G	1	POST #1 - (SYTP) (4'-9 1/2")
15000G	1	POST #2 - (SYTP) (6'-0")
533G	6	POST #3 THRU #8 - I-BEAM (W6 X 8.5) (6'-0")
4076B	7	BLOCKOUT - WOOD (ROUTED) (6" x 8" x 14")
6777B	7	BLOCKOUT - COMPOSITE (4" x 7 1/2" x 14")
15204A	1	ANCHOR PADDLE
15207G	1	ANCHOR KEEPER PLATE (24 GA)
15206G	1	ANCHOR PLATE WASHER (1/2" THICK)
15201G	2	ANCHOR POST ANGLE (10" LONG)
15202G	1	ANGLE STRUT
HARDWARE		
4902G	1	1" ROUND WASHER F436
3908G	1	1" HEAVY HEX NUT A563 GR. DH
3717G	2	3/4" x 2 1/2" HEX BOLT A325
3701G	4	3/4" ROUND WASHER F436
3704G	2	3/4" HEAVY HEX NUT A563 GR. DH
3360G	16	5/8" x 1 1/4" W-BEAM RAIL SPLICE BOLTS HGR
3340G	25	5/8" W-BEAM RAIL SPLICE NUTS HGR
3500G	7	5/8" x 10" HGR POST BOLT A307
3391G	1	5/8" x 1 3/4" HEX HD BOLT A325
4489G	1	5/8" x 9" HEX HD BOLT A325
4372G	4	5/8" WASHER F436
105285G	2	5/8" x 2 1/2" HEX HD BOLT GR-5
105286G	1	5/8" x 1 1/2" HEX HD BOLT GR-5
3240G	6	5/8" ROUND WASHER (WIDE)
3245G	3	5/8" HEX NUT A563 GR. DH
5852B	1	HIGH INTENSITY REFLECTIVE SHEETING - SEE NOTE: B

Texas Department of Transportation  
 Design Division Standard

**TRINITY HIGHWAY  
 SOFTSTOP END TERMINAL  
 MASH - TL-3  
 SGT (10S) 31-16**

FILE: sgt10s3116	DN: TxDOT	CR: KM	DW: VP	CR: MB/VP
© TxDOT: JULY 2016	CONT	SECT	JOB	HIGHWAY
REVISIONS	6435	38	001	IH10, etc
DIST	COUNTY	SHEET NO.		
BMT	JEFFERSON, etc	56		

DATE: 2/28/2023  
 FILE: T:\BMT\AO\01 - CSJ Project Files\6435-38-001\MBGF\_2024\Design\GNV\gfm\g.dgn

NOTE: THIS STANDARD IS A BASIC REPRESENTATION OF THE SoftStop END TERMINAL, IT IS NOT INTENDED TO REPLACE THE PRODUCT DESCRIPTION ASSEMBLY MANUAL.



DISCLAIMER: The use of this standard is governed by the "Texas Engineering Practice Act". No warranty of any kind is made by TxDOT for any purpose whatsoever. TxDOT assumes no responsibility for the conversion of this standard to other formats or for incorrect results or damages resulting from its use.

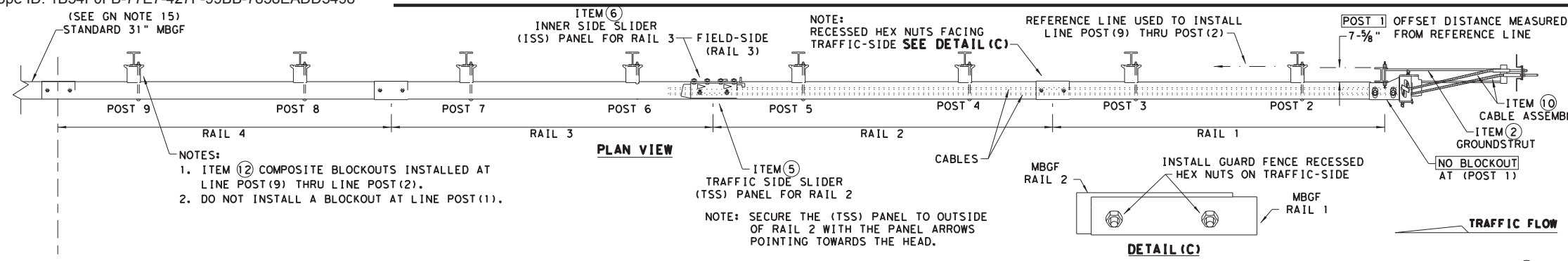

NOTES:  
 1. ITEM ② COMPOSITE BLOCKOUTS INSTALLED AT LINE POST (9) THRU LINE POST (2).  
 2. DO NOT INSTALL A BLOCKOUT AT LINE POST (1).

NOTE: SECURE THE (TSS) PANEL TO OUTSIDE OF RAIL 2 WITH THE PANEL ARROWS POINTING TOWARDS THE HEAD.

- GENERAL NOTES**
- FOR SPECIFIC INFORMATION REGARDING INSTALLATION AND TECHNICAL GUIDANCE OF THE SYSTEM, CONTACT: LINDSAY TRANSPORTATION SOLUTIONS (LTS) - BARRIER SYSTEMS, INC. AT (707) 374-6800
  - FOR INSTALLATION, REPAIR, & MAINTENANCE REFER TO THE MAX-TENSION INSTALLATION INSTRUCTION MANUAL, P/N MANMAX REV D (ECN 3516).
  - APPLY HIGH INTENSITY REFLECTIVE SHEETING, "OBJECT MARKER" ON THE FRONT FACE OF THE DEVICE PER MANUFACTURER'S RECOMMENDATIONS. OBJECT MARKER SHALL CONFORM TO THE STANDARDS REQUIRED IN TEXAS MUTCD.
  - FOR POST (LEAVE-OUT) INSTALLATION AND GUIDANCE SEE TxDOT'S LATEST ROADWAY MOW STRIP STANDARD.
  - ALL STEEL COMPONENTS ARE GALVANIZED PER ASTM A123 OR EQUIVALENT UNLESS OTHERWISE STATED.
  - SYSTEM SHOWN USING STEEL WIDE FLANGE POST WITH COMPOSITE BLOCKOUTS.
  - COMPOSITE MATERIAL BLOCKOUT THAT MEETS THE REQUIREMENTS OF DMS-7210, MAY BE SUBSTITUTED FOR BLOCKOUTS SIMILAR DIMENSIONS. SEE CONSTRUCTION DIVISION MATERIAL PRODUCER LIST (MPL) FOR CERTIFIED PRODUCERS.
  - REFER TO INSTALLATION MANUAL FOR SPECIFIC PANEL LAPPING GUIDANCE.
  - IF SOLID ROCK IS ENCOUNTERED SEE THE MANUFACTURER'S INSTALLATION MANUAL FOR INSTALLATION GUIDANCE.
  - POSTS SHALL NOT BE SET IN CONCRETE.
  - A DRIVING CAP WITH A TIMBER OR PLASTIC INSERT SHALL BE USED WHEN DRIVING POST TO PREVENT DAMAGE TO THE GALVANIZING ON TOP OF THE POST.
  - MAX-TENSION SYSTEM SHALL NEVER BE INSTALLED WITHIN A CURVED SECTION OF GUARDRAIL.
  - IF A DELINEATION MARKER IS REQUIRED, MARKER SHALL BE IN ACCORDANCE WITH TEXAS MUTCD.
  - THE SYSTEM IS SHOWN WITH 12'-6" MBGF PANELS, 25'-0" MBGF PANELS ARE ALSO ALLOWED.
  - A MINIMUM OF 12'-6" OF 12GA. MBGF IS REQUIRED IMMEDIATELY DOWNSTREAM OF THE MAX-TENSION SYSTEM.

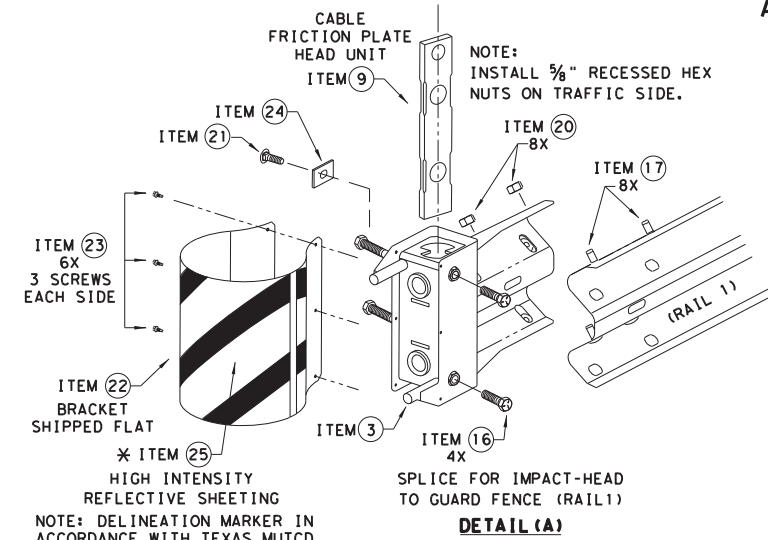
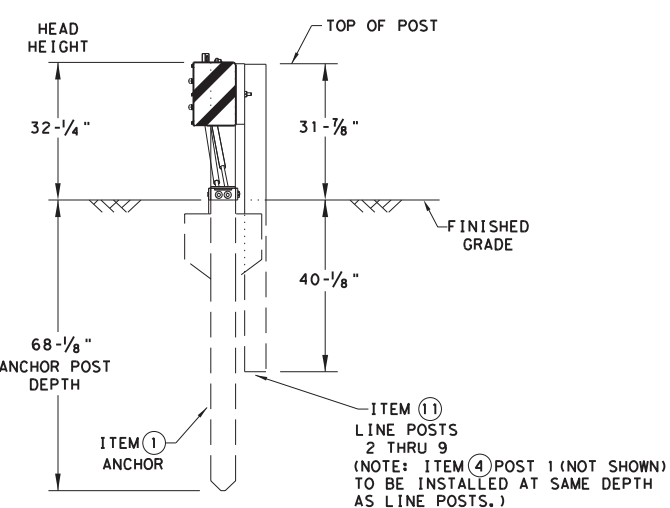
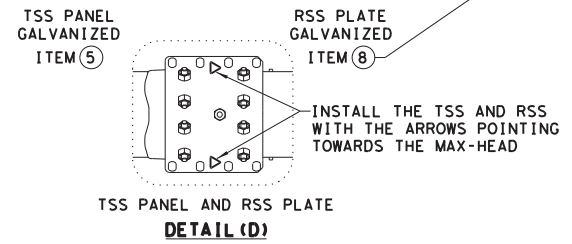
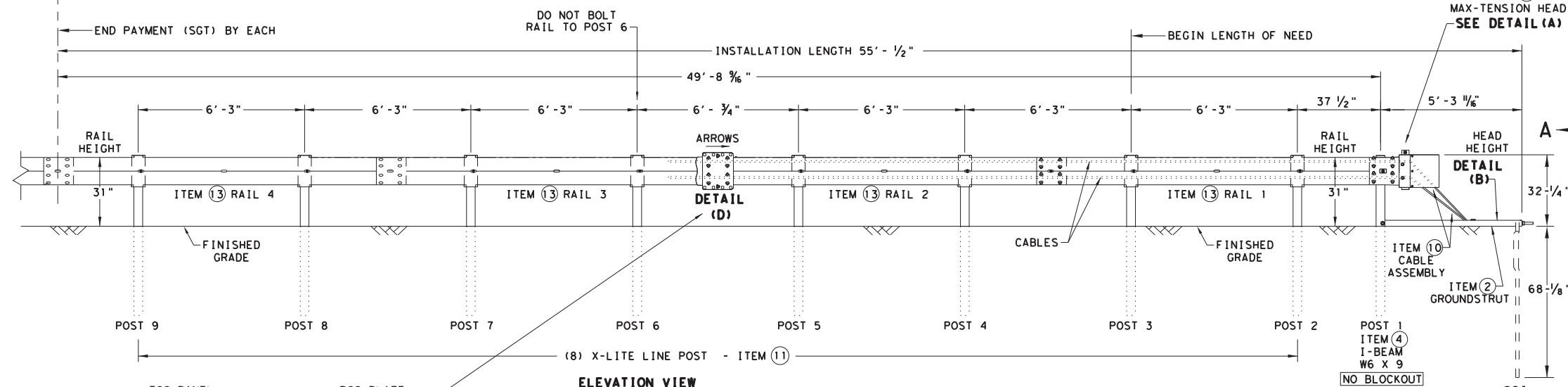

ITEM #	PART NUMBER	DESCRIPTION	QTY
1	BSI-1610060-00	SOIL ANCHOR - GALVANIZED	1
2	BSI-1610061-00	GROUND STRUT - GALVANIZED	1
3	BSI-1610062-00	MAX-TENSION IMPACT HEAD	1
4	BSI-1610063-00	W6x9 I-BEAM POST 6FT. -GALVANIZED	1
5	BSI-1610064-00	TSS PANEL - TRAFFIC SIDE SLIDER	1
6	BSI-1610065-00	ISS PANEL - INNER SIDE SLIDER	1
7	BSI-1610066-00	TOOTH - GEOMET	1
8	BSI-1610067-00	RSS PLATE - REAR SIDE SLIDER	1
9	B061058	CABLE FRICTION PLATE - HEAD UNIT	1
10	BSI-1610069-00	CABLE ASSEMBLY - MASH X-TENSION	2
11	BSI-1012078-00	X-LITE LINE POST - GALVANIZED	8
12	B090534	8" W-BEAM COMPOSITE-BLOCKOUT XT110	8
13	BSI-4004386	12'-6" W-BEAM GUARD FENCE PANELS 12GA.	4
14	BSI-1102027-00	X-LITE SQUARE WASHER	1
15	BSI-2001886	5/8" X 7" THREAD BOLT HH (GR.5)GEOMET	1
16	BSI-2001885	3/4" X 3" ALL-THREAD BOLT HH (GR.5)GEOMET	4
17	4001115	5/8" X 1 1/4" GUARD FENCE BOLTS (GR.2)MGAL	48
18	2001840	5/8" X 10" GUARD FENCE BOLTS MGAL	8
19	2001636	5/8" WASHER F436 STRUCTURAL MGAL	2
20	4001116	5/8" RECESSED GUARD FENCE NUT (GR.2)MGAL	59
21	BSI-2001888	5/8" X 2" ALL THREAD BOLT (GR.5)GEOMET	1
22	BSI-1701063-00	DELINEATION MOUNTING (BRACKET)	1
23	BSI-2001887	1/4" X 3/4" SCREW SD HH 410SS	7
24	4002051	GUARDRAIL WASHER RECT AASHTO FWRO3	1
25	SEE NOTE BELOW	HIGH INTENSITY REFLECTIVE SHEETING	1
26	4002337	8" W-BEAM TIMBER-BLOCKOUT, PDB01B	8
27	BSI-4004431	25' W-BEAM GUARDRAIL PANEL, 8-SPACE, 12GA.	2
28	MANMAX Rev- (D)	MAX-TENSION INSTALLATION INSTRUCTIONS	1

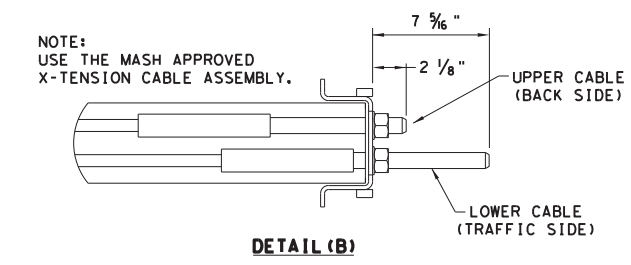

\* TO BE PROVIDED BY DISTRIBUTOR OR CONTRACTOR.  
 \*\* ALTERNATIVE ITEMS NOT SHOWN. ITEM (26) 8" WOOD-BLOCKOUTS ITEM (27) 25' GUARD FENCE PANELS

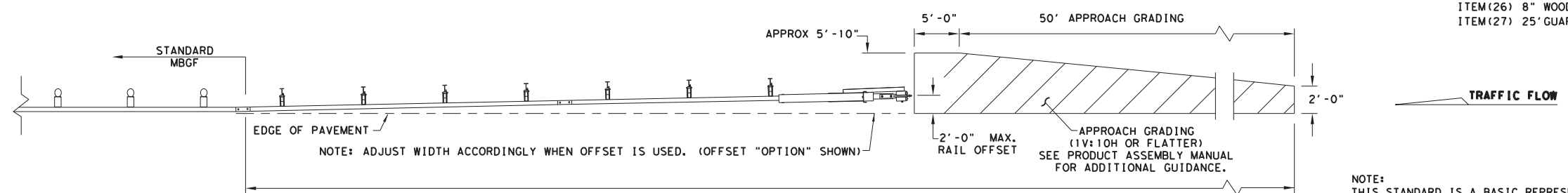

NOTE: TxDOT GENERIC APPROACH GRADING LAYOUT USED FOR ALL TANGENT TYPE END TREATMENTS.

NOTE: THIS STANDARD IS A BASIC REPRESENTATION OF THE MAX-TENSION END TERMINAL, IT IS NOT INTENDED TO REPLACE THE PRODUCT DESCRIPTION ASSEMBLY MANUAL.

**MAX-TENSION END TERMINAL**  
**MASH - TL-3**  
**SGT (11S) 31-18**

FILE: sg11s3118.dgn	DN: TxDOT	CK: KM	DW: TxDOT	CK: CL
© TxDOT: FEBRUARY 2018	CONT	SECT	JOB	HIGHWAY
REVISIONS	6435	38	001	IH10, etc
DIST	COUNTY		SHEET NO.	
BMT	JEFFERSON, etc		57	

DISCLAIMER: THIS STANDARD IS GOVERNED BY THE "TEXAS ENGINEERING PRACTICE ACT". NO WARRANTY OF ANY KIND IS MADE BY TXDOT FOR ANY PURPOSE WHATSOEVER. TXDOT ASSUMES NO RESPONSIBILITY FOR THE CONVERSION OF THIS STANDARD TO OTHER FORMATS OR FOR INCORRECT RESULTS OR DAMAGES RESULTING FROM ITS USE.  
 DATE: 2/28/2023  
 FILE: T:\BMT\AO\01 - CSJ Project Files\6435-38-001\MBGF 2024\Des\gn\DCN\gfm&mg.dgn

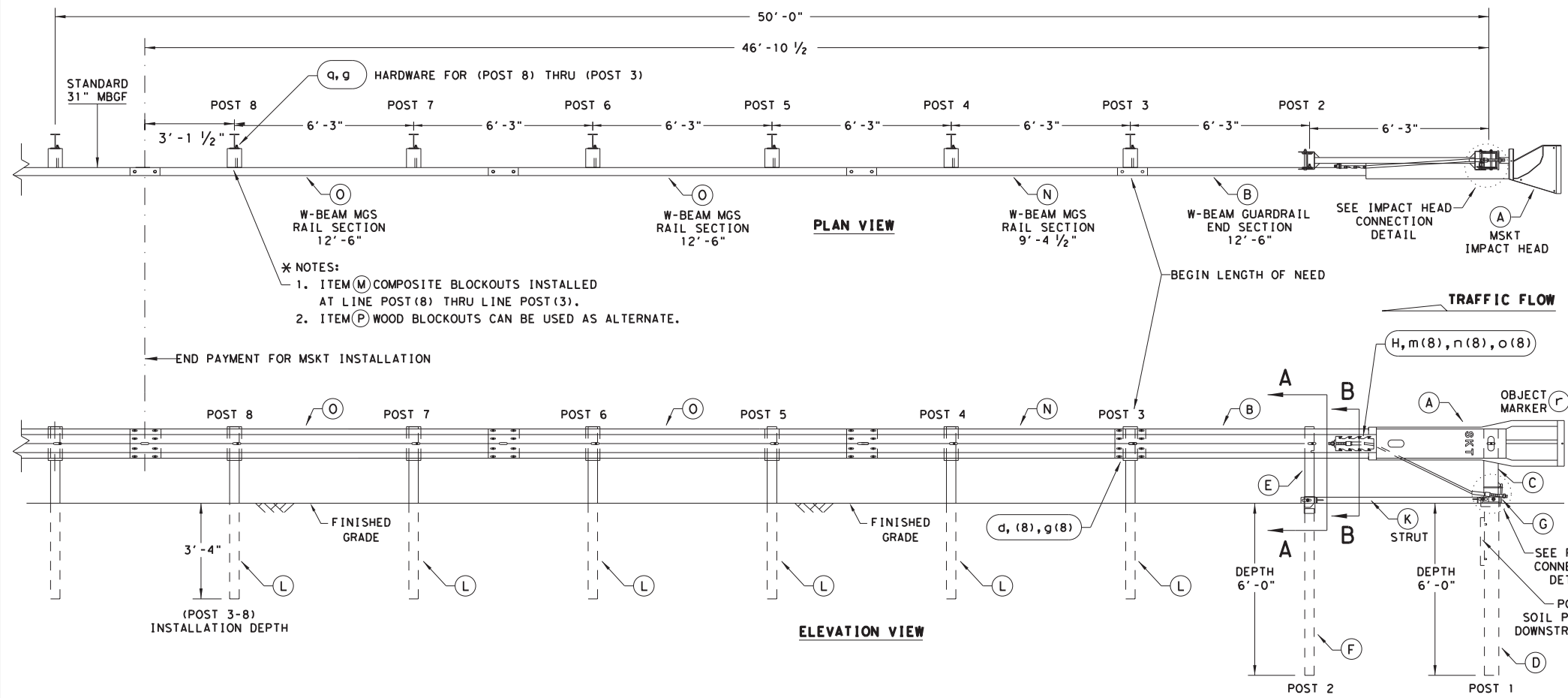

- \* NOTES:**
- ITEM (M) COMPOSITE BLOCKOUTS INSTALLED AT LINE POST (8) THRU LINE POST (3).
  - ITEM (P) WOOD BLOCKOUTS CAN BE USED AS ALTERNATE.

- GENERAL NOTES**
- FOR SPECIFIC INFORMATION REGARDING INSTALLATION AND TECHNICAL GUIDANCE OF THE SYSTEM, CONTACT: ROAD SYSTEMS, INC. (432)263-2435. 3616 OLD HOWARD COUNTY AIRPORT, BIG SPRING, TX 79720
  - FOR INSTALLATION, REPAIR AND MAINTENANCE REFER TO THE: MSKT END TERMINAL, PRODUCT DESCRIPTION ASSEMBLY MANUAL (PUBLICATION-062717).
  - APPLY HIGH INTENSITY REFLECTIVE SHEETING, "OBJECT MARKER" ON THE FRONT FACE OF THE DEVICE PER MANUFACTURER'S RECOMMENDATIONS. OBJECT MARKER SHALL CONFORM TO THE STANDARDS REQUIRED IN TEXAS MUTCD.
  - FOR POST (LEAVE-OUT) INSTALLATION AND GUIDANCE SEE TXDOT'S LATEST ROADWAY MOW STRIP STANDARD.
  - HARDWARE (BOLTS, NUTS, & WASHERS) SHALL BE GALVANIZED IN ACCORDANCE WITH ITEM 445, "GALVANIZING". FITTINGS SHALL BE SUBSIDIARY TO THE BID ITEM.
  - SYSTEM SHOWN USING STEEL WIDE FLANGE POSTS WITH COMPOSITE BLOCKOUTS.
  - A COMPOSITE MATERIAL BLOCKOUTS THAT MEETS THE REQUIREMENTS OF DMS-7210, MAY BE SUBSTITUTED FOR BLOCKOUTS OF SIMILAR DIMENSIONS. SEE CONSTRUCTION DIVISION MATERIAL PRODUCER LIST (MPL) FOR CERTIFIED PRODUCERS.
  - IF SOLID ROCK IS ENCOUNTERED IN THE AREA OF (POST 1) AND / OR (POST 2) CONTACT THE MANUFACTURER, & REFER TO THE LATEST ROADWAY MBGF STANDARD FOR INSTALLATION GUIDANCE.
  - POSTS SHALL NOT BE SET IN CONCRETE.
  - SYSTEM MUST BE ATTACHED TO STANDARD 31" MBGF.
  - UNDER NO CIRCUMSTANCES SHALL THE GUARDRAIL WITHIN THE MSKT SYSTEM BE CURVED.
  - A FLARE RATE OF UP TO 25:1 MAY BE USED TO PREVENT THE TERMINAL HEAD FROM ENCRANCHING ON THE SHOULDER. THE FLARE MAY BE DECREASED OR ELIMINATED FOR SPECIFIC INSTALLATIONS, IF DIRECTED BY THE ENGINEER.
  - THE SYSTEM IS SHOWN WITH TWO 12'-6" MBGF PANELS, ONE 25'-0" MBGF PANEL IS ALSO ALLOWED IN THEIR PLACE.
  - A DRIVING CAP WITH A TIMBER OR PLASTIC INSERT SHALL BE USED WHEN DRIVING POSTS 3-8 TO PREVENT DAMAGE TO THE GALVANIZING ON TOP OF THE POST. SPECIAL DRIVING CAP TO BE USED ON LOWER POSTS 1 & 2 TO PREVENT DAMAGE TO THE WELDED PLATES.

ITEM	QTY	MAIN SYSTEM COMPONENTS	ITEM NUMBERS
A	1	MSKT IMPACT HEAD	MS3000
B	1	W-BEAM GUARDRAIL END SECTION, 12 Go.	SF1303
C	1	POST 1 - TOP (6" X 6" X 1/8" TUBE)	MTPHP1A
D	1	POST 1 - BOTTOM (6' W6X15)	MTPHP1B
E	1	POST 2 - ASSEMBLY TOP	UHP2A
F	1	POST 2 - ASSEMBLY BOTTOM (6' W6X9)	HP2B
G	1	BEARING PLATE	E750
H	1	CABLE ANCHOR BOX	S760
J	1	BCT CABLE ANCHOR ASSEMBLY	E770
K	1	GROUND STRUT	MS785
L	6	W6x9 OR W6x8.5 STEEL POST	P621
M	6	COMPOSITE BLOCKOUTS	CBSP-14
N	1	W-BEAM MGS RAIL SECTION (9'-4 1/2")	G12025
O	2	W-BEAM MGS RAIL SECTION (12'-6")	G1203A
P	6	WOOD BLOCKOUT 6" X 8" X 14"	P675
Q	1	W-BEAM MGS RAIL SECTION (25'-0")	G1209
SMALL HARDWARE			
o	2	5/8" x 1" HEX BOLT (GRD 5)	B5160104A
b	4	5/8" WASHER	W0516
c	2	5/8" HEX NUT	N0516
d	25	5/8" Dia. x 1 1/4" SPLICE BOLT (POST 2)	B580122
e	2	5/8" Dia. x 9" HEX BOLT (GRD A449)	B580904A
f	3	5/8" WASHER	W050
g	33	5/8" Dia. H.G.R NUT	N050
h	1	3/4" Dia. x 8 1/2" HEX BOLT (GRD A449)	B340854A
j	1	3/4" Dia. HEX NUT	N030
k	2	1 ANCHOR CABLE HEX NUT	N100
l	2	1 ANCHOR CABLE WASHER	W100
m	8	1/2" x 1 1/4" A325 BOLT WITH CAPTIVE WASHER	SB12A
n	8	1/2" STRUCTURAL NUTS	N012A
o	8	1 1/8" O.D. x 3/8" I.D. STRUCTURAL WASHERS	W012A
p	1	BEARING PLATE RETAINER TIE	CT-100ST
q	6	5/8" x 10" H.G.R. BOLT	B581002
r	1	OBJECT MARKER 18" X 18"	E3151

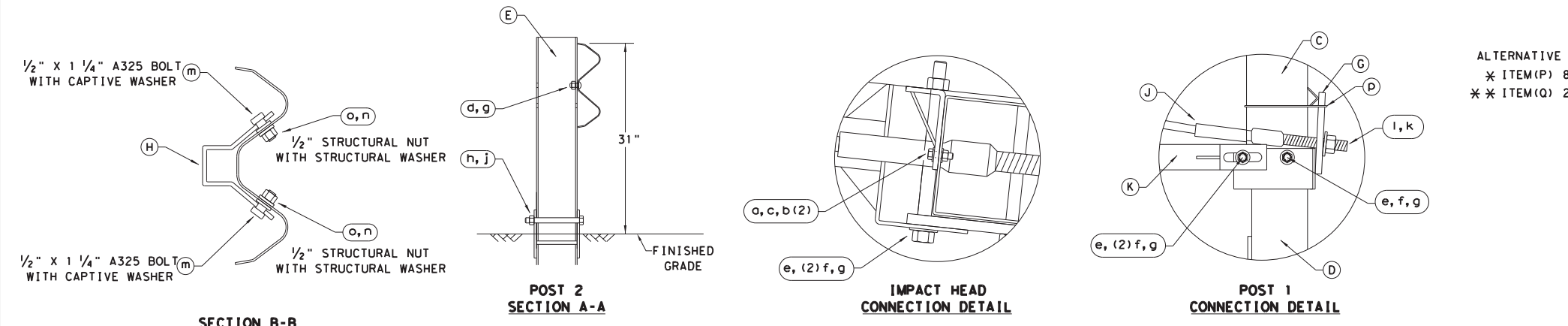

ALTERNATIVE ITEMS NOT SHOWN. \* \*  
 \* ITEM (P) 8" WOOD-BLOCKOUT  
 \* \* ITEM (Q) 25' GUARD FENCE PANEL

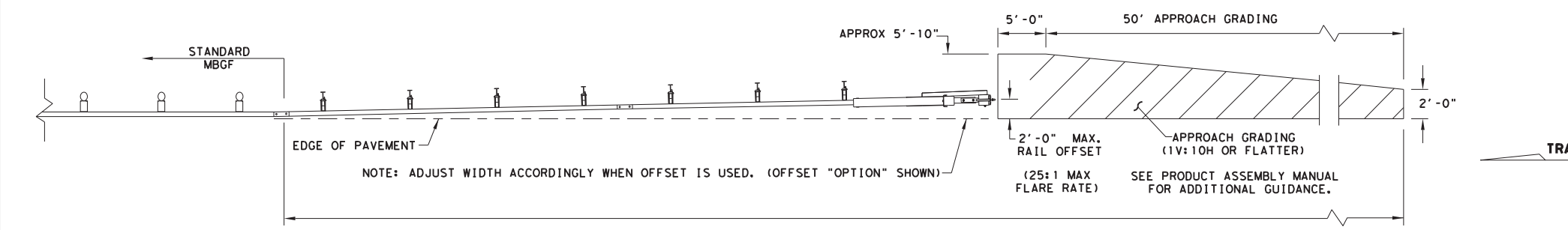

NOTE: TXDOT GENERIC APPROACH GRADING LAYOUT USED FOR ALL TANGENT TYPE END TREATMENTS.

NOTE: THIS STANDARD IS A BASIC REPRESENTATION OF THE MSKT END TERMINAL, IT IS NOT INTENDED TO REPLACE THE PRODUCT DESCRIPTION ASSEMBLY MANUAL.

**Design Division Standard**

## SINGLE GUARDRAIL TERMINAL

### MSKT-MASH-TL-3

### SGT (12S) 31-18

FILE: sgt12s3118.dgn	DN: TXDOT	CK: KM	DW: VP	CK: CL
© TXDOT: APRIL 2018	CONT	SECT	JOB	HIGHWAY
REVISIONS	6435	38	001	IH10, etc
	DIST	COUNTY		SHEET NO.
	BMT	JEFFERSON, etc		58

DISCLAIMER: THE USE OF THIS STANDARD IS GOVERNED BY THE "TEXAS ENGINEERING PRACTICE ACT". NO WARRANTY OF ANY KIND IS MADE BY TXDOT FOR ANY PURPOSE WHATSOEVER. TXDOT ASSUMES NO RESPONSIBILITY FOR THE CONVERSION OF THIS STANDARD TO OTHER FORMATS OR FOR INCORRECT RESULTS OR DAMAGES RESULTING FROM ITS USE.

DATE: 2/28/2023  
FILE: T:\BMT\AO\01 - CSJ Project Files\6435-38-001\MBGF 2024\Design\GNG\gfmq.dgn

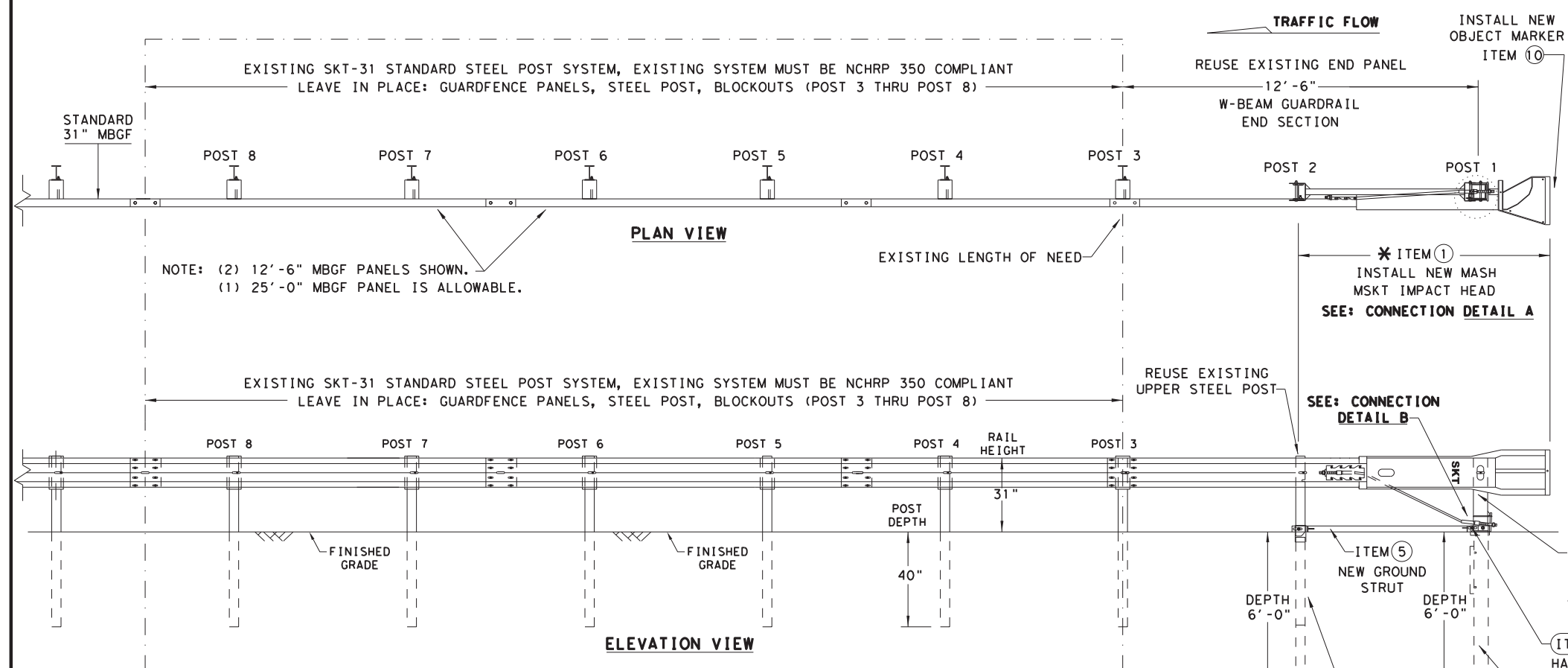

**GENERAL NOTES**

- FOR SPECIFIC INFORMATION REGARDING INSTALLATION AND TECHNICAL GUIDANCE OF THE SYSTEM, CONTACT: ROAD SYSTEMS, INC. (432)263-2435. 3616 OLD HOWARD COUNTY AIRPORT, BIG SPRING, TX 79720
- FOR INSTALLATION, REPAIR AND MAINTENANCE REFER TO: MSKT END TERMINAL, PRODUCT DESCRIPTION ASSEMBLY MANUAL (PUBLICATION-062717).
- APPLY HIGH INTENSITY REFLECTIVE SHEETING, "OBJECT MARKER" ON THE FRONT FACE OF THE DEVICE PER MANUFACTURER'S RECOMMENDATIONS. OBJECT MARKER SHALL CONFORM TO THE STANDARDS REQUIRED IN TEXAS MUTCD.
- FOR POST (LEAVE-OUT) INSTALLATION AND GUIDANCE SEE TXDOT'S LATEST ROADWAY MOW STRIP STANDARD.
- HARDWARE (BOLTS, NUTS, & WASHERS) SHALL BE GALVANIZED IN ACCORDANCE WITH ITEM 445, "GALVANIZING". FITTINGS SHALL BE SUBSIDIARY TO THE BID ITEM.
- IF SOLID ROCK IS ENCOUNTERED IN THE AREA OF (POST 1) AND / OR (POST 2) CONTACT THE MANUFACTURER, AND REFER TO THE LATEST ROADWAY MBGF STANDARD FOR INSTALLATION GUIDANCE.
- POSTS SHALL NOT BE SET IN CONCRETE.
- THE EXISTING SKT 31" STANDARD STEEL POST SYSTEM MUST BE THOROUGHLY INSPECTED, AND DETERMINED TO BE INTACT, AND FREE OF ANY DAMAGE OR DEFECTS BEFORE RETROFITTING. THIS INSPECTION INCLUDES COMPLETING THE MSKT RETROFIT INSPECTION CHECKLIST FOR THE EXISTING SKT 31" STEEL POST NCHRP 350 SYSTEM. ALL EXISTING, AND REUSABLE PARTS MUST BE FREE OF ANY DAMAGE FOR A MASH COMPLIANT RETROFIT.
- UNDER NO CIRCUMSTANCES SHALL THE GUARDRAIL WITHIN THE MSKT SYSTEM BE CURVED.
- A FLARE RATE OF UP TO 25:1 MAY BE USED TO PREVENT THE TERMINAL HEAD FROM ENCRANCHING ON THE SHOULDER. THE FLARE MAY BE DECREASED OR ELIMINATED FOR SPECIFIC INSTALLATIONS, IF DIRECTED BY THE ENGINEER.
- SPECIAL DRIVING CAP TO BE USED WHEN DRIVING (LOWER POSTS 1 & 2) TO PREVENT DAMAGE TO THE WELDED PLATES.

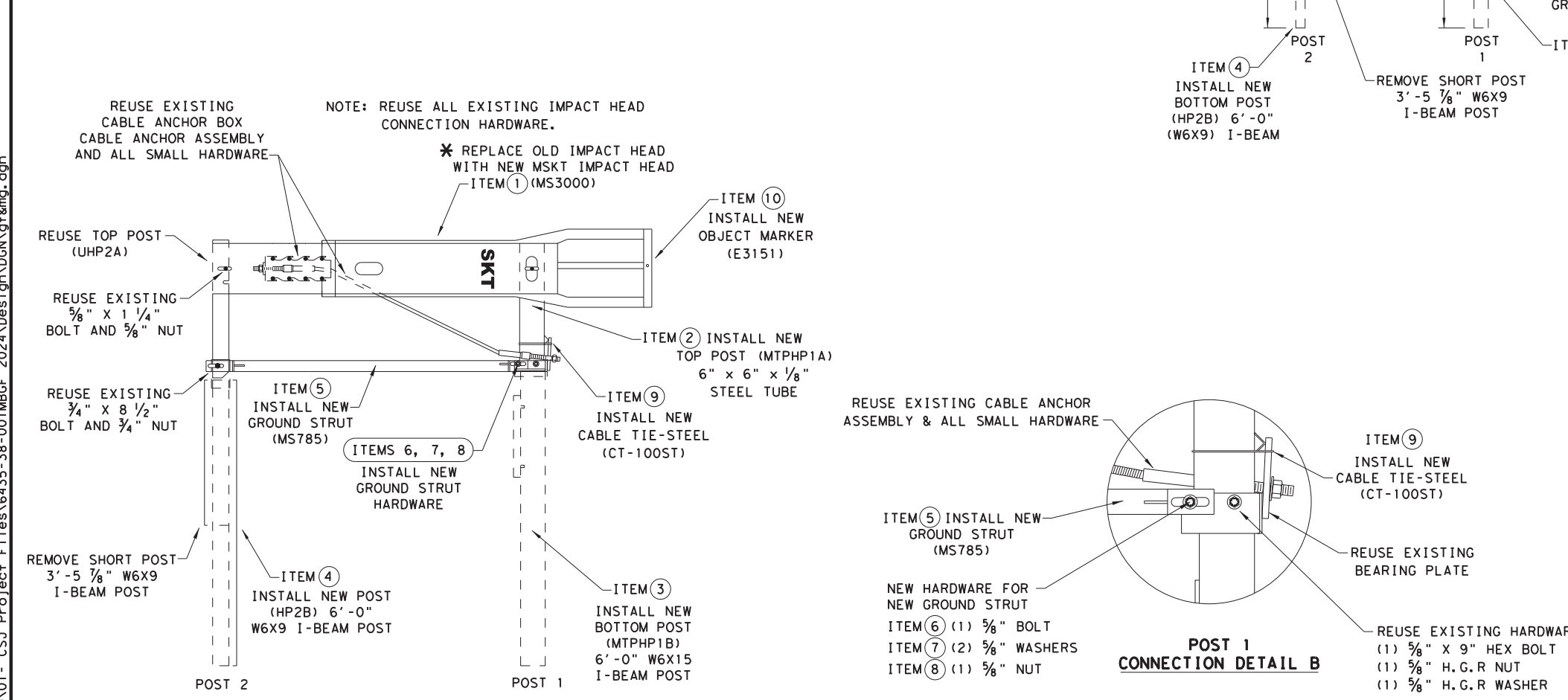

**CONNECTION DETAIL A  
IMPACT HEAD (POST 1 & POST 2)**

**POST 1  
CONNECTION DETAIL B**

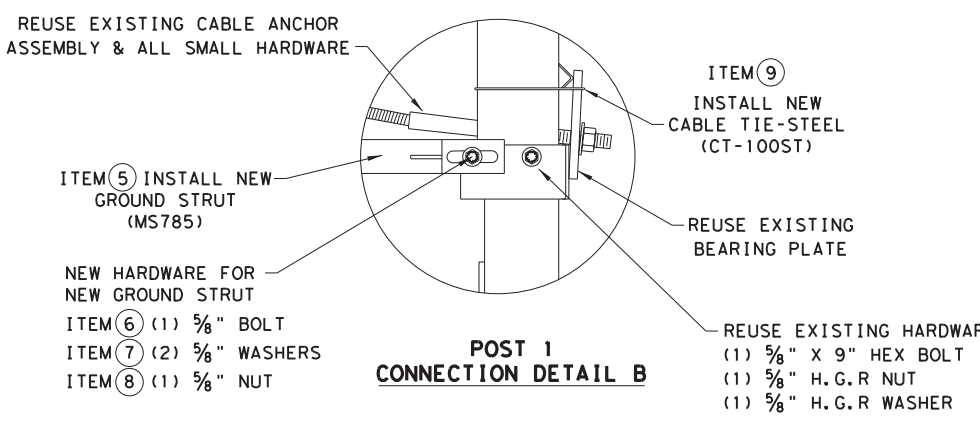

ITEMS	QTY	MAIN SYSTEM COMPONENTS	PART NUMBERS
*	1	MSKT IMPACT HEAD	MS3000
	1	POST 1 - TOP (6" X 6" X 1/8" TUBE)	MTPHP1A
	1	POST 1 - BOTTOM (6' W6X15)	MTPHP1B
	1	POST 2 - ASSEMBLY BOTTOM (6' W6X9)	HP2B
	1	GROUND STRUT	MS785
	1	5/8" X 9" HEX BOLT (GRD A449)	B580904A
	2	5/8" WASHERS	W050
	1	5/8" H.G.R. NUT	N050
	1	CABLE TIE-STEEL	CT-100ST
*	1	OBJECT MARKER 18" X 18"	E3151

**COMPONENTS REQUIRED TO RETROFIT: EXISTING 31" STEEL POST (NCHRP 350 SKT) GUARDRAIL TERMINAL WITH THE NEW 31" (MASH COMPLIANT MSKT IMPACT HEAD).**  
 \* IF THE EXISTING NCHRP 350 (31" STEEL POST SKT) ALREADY HAS THE MSKT IMPACT HEAD THERE IS NO NEED TO REPLACE THE IMPACT HEAD OR OBJECT MARKER AS LONG AS IT IS NOT DAMAGED.

NOTE: THIS STANDARD IS A BASIC REPRESENTATION OF THE EXISTING; SKT END TERMINAL RETROFITTED TO THE MSKT MASH COMPLIANT TERMINAL, IT IS NOT INTENDED TO REPLACE THE PRODUCT DESCRIPTION ASSEMBLY MANUAL.

Design Division Standard

## RETROFIT STANDARD SKT 31" STEEL POST SYSTEM TO MASH MSKT SGT (13S) 31-18

FILE: sgt13s3118.dgn	DN: TxDOT	CK: KM	DW: VP	CK: CL
© TXDOT: APRIL 2018	CONT	SECT	JOB	HIGHWAY
REVISIONS	6435	38	001	IH10, etc
	DIST	COUNTY	SHEET NO.	
	BMT	JEFFERSON, etc	59	

DISCLAIMER: THE USE OF THIS STANDARD IS GOVERNED BY THE "TEXAS ENGINEERING PRACTICE ACT". NO WARRANTY OF ANY KIND IS MADE BY TXDOT FOR ANY PURPOSE WHATSOEVER. TXDOT ASSUMES NO RESPONSIBILITY FOR THE CONVERSION OF THIS STANDARD TO OTHER FORMATS OR FOR INCORRECT RESULTS OR DAMAGES RESULTING FROM ITS USE.

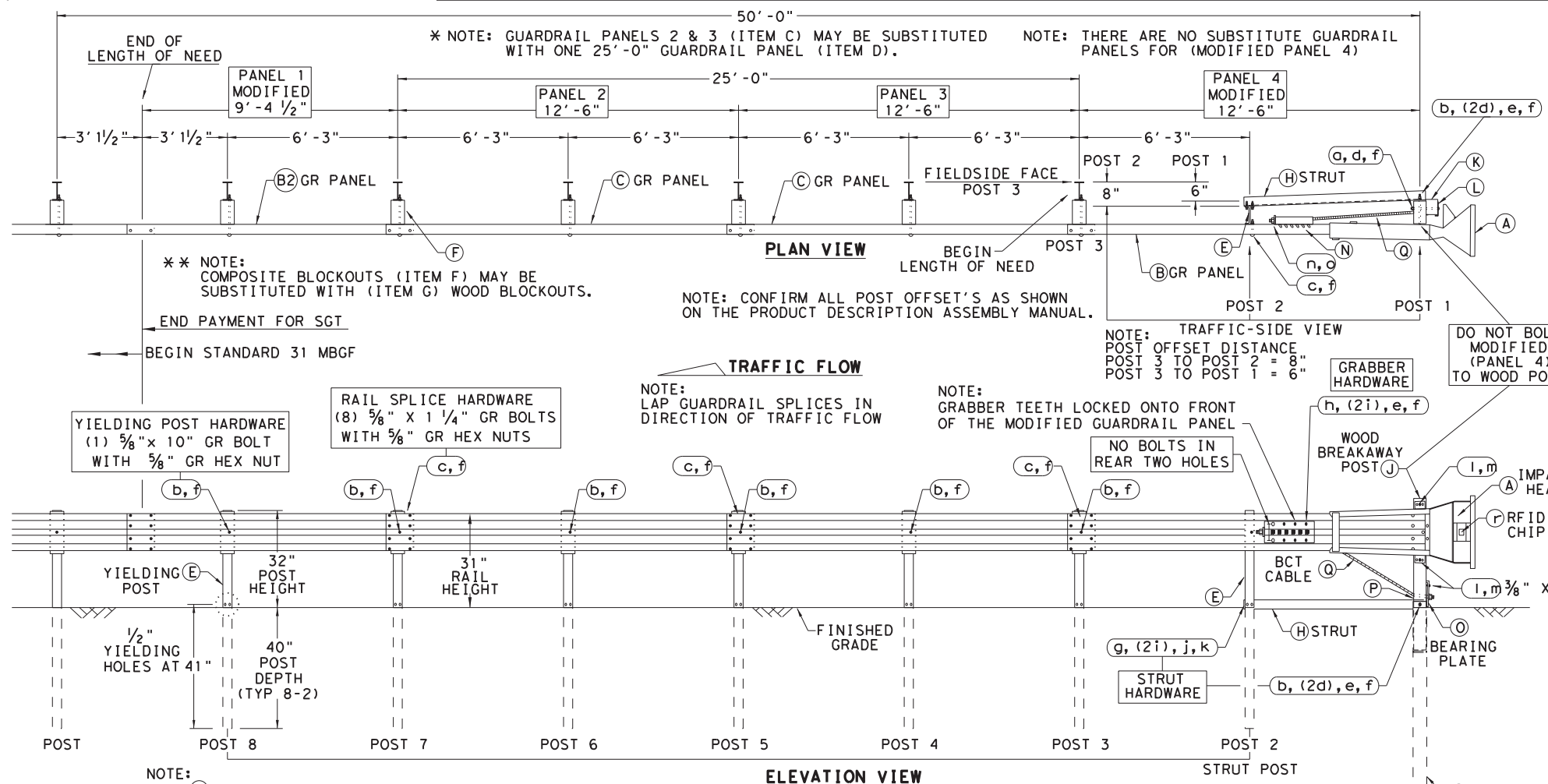

- ### GENERAL NOTES
- FOR SPECIFIC INFORMATION REGARDING INSTALLATION AND TECHNICAL GUIDANCE OF THE SYSTEM, CONTACT: SPIG INDUSTRY, INC. AT 1(267) 644-9510. 14675 INDUSTRIAL PARK RD; BRISTOL, VA 24202
  - FOR INSTALLATION, REPAIR AND MAINTENANCE REFER TO THE MANUFACTURER'S; SGET END TERMINAL, PRODUCT DESCRIPTION ASSEMBLY MANUAL.
  - MANUFACTURER WILL APPLY HIGH INTENSITY REFLECTIVE SHEETING, "OBJECT MARKER" TO THE FACE PLATE OF THE DEVICE PER MANUFACTURER'S RECOMMENDATIONS. THE OBJECT MARKER SHALL CONFORM TO THE STANDARDS REQUIRED IN TEXAS MUTCD.
  - THE NOMINAL HEIGHT OF THE GUARDRAIL BEAM IS 31 INCHES WITH A TOLERANCE OF +/- ONE INCH.
  - FOR POST (LEAVE-OUT) INSTALLATION AND GUIDANCE SEE TXDOT'S LATEST ROADWAY MOW STRIP STANDARD.
  - (POST 2 THROUGH POST 8) ARE MODIFIED STEEL-YIELDING POSTS WITH YIELDING HOLES AT GROUND LEVEL. THERE ARE NO SUBSTITUTE POSTS.
  - POSTS SHALL NOT BE SET IN CONCRETE.
  - IF SOLID ROCK IS ENCOUNTERED FOR ANY OF THE POSTS IN THE SYSTEM, CONTACT THE MANUFACTURER FOR SPECIFIC INSTALLATION GUIDANCE.
  - HARDWARE (BOLTS, NUTS, & WASHERS) SHALL BE GALVANIZED IN ACCORDANCE WITH ITEM 445, "GALVANIZING". FITTINGS SHALL BE SUBSIDIARY TO THE BID ITEM.
  - A COMPOSITE MATERIAL BLOCKOUT THAT MEETS DMS-7210 REQUIREMENTS MAY BE SUBSTITUTED FOR AN APPROVED WOOD BLOCKOUT. SEE CONSTRUCTION DIVISION MATERIAL PRODUCER LIST (MPL) FOR CERTIFIED PRODUCERS.
  - THE ENTIRE SYSTEM MUST BE INSTALLED IN A STRAIGHT LINE WITHOUT ANY CURVE. HOWEVER, THE SYSTEM CAN BE OFFSET BY TWO FEET AS SHOWN ON THE APPROACH GRADING DETAIL TO HELP OFF-SET THE IMPACT HEAD FROM SHOULDER OF THE ROAD.

ITEM	QTY	MAIN SYSTEM COMPONENTS	ITEM #
A	1	SGET IMPACT HEAD	SIH1A
B	1	MODIFIED GUARDRAIL PANEL 12'-6" 12GA	126SPZGP
B2	1	MODIFIED GUARDRAIL PANEL 9'-4 1/2" 12GA	GP94
C	2	STANDARD GUARDRAIL PANEL 12'-6" 12GA	GP126
D	1	STANDARD GUARDRAIL PANEL 25'-0" 12GA	GP25
E	7	MODIFIED YIELDING I-BEAM POST W6x8.5	YP6MOD
F	6	COMPOSITE BLOCKOUT 6" X 8" X 14"	CBO8
G	6	WOOD BLOCKOUT 6" X 8" X 14"	WBO8
H	1	STRUT 3" X 3" X 80" X 1/4" A36 ANGLE	STR80
I	1	FOUNDATION TUBE 6" X 8" X 72" X 3/16"	FNDT6
J	1	WOOD BREAKAWAY POST 5 1/2" X 7 1/2" X 50"	WBRK50
K	1	WOOD STRIKE BLOCK	WSBLK14
L	1	STRIKE PLATE 1/4" A36 BENT PLATE	SPLT8
M	1	REINFORCEMENT PLATE 12 GA. GR55	REPLT17
N	1	GUARDRAIL GRABBER 2 1/2" X 2 1/2" X 16 1/2"	GGR17
O	1	BEARING PLATE 8" X 8 5/8" X 5/8" A36	BPLT8
P	1	PIPE SLEEVE 4 1/4" X 2 3/8" O.D. (2 1/8" I.D.)	PSLV4
Q	1	BCT CABLE 3/4" X 81" LENGTH	CBL81

ITEM	QTY	SMALL HARDWARE	ITEM #
a	1	5/8" X 12" GUARDRAIL BOLT 307A HDG	12GRBLT
b	7	5/8" X 10" GUARDRAIL BOLT 307A HDG	10GRBLT
c	33	5/8" X 1 1/4" GR SPlice BOLTS 307A HDG	1GRBLT
d	3	5/8" FLAT WASHER F436 A325 HDG	58FW436
e	1	5/8" LOCK WASHER HDG	58LW
f	39	5/8" GUARDRAIL HEX NUT HDG	58HN563
g	2	1/2" X 2" STRUT BOLT A325 HDG	2BLT
h	6	1/2" X 1 1/4" PLATE BOLT A325 HDG	125BLT
i	16	1/2" FLAT WASHER F436 A325 HDG	12FWF436
j	8	1/2" LOCK WASHER HDG	12LW
k	8	1/2" HEX NUT A563 HDG	12HN563
l	4	3/8" X 3" HEX LAG SCREW GR5 HDG	38LS
m	4	3/8" FLAT WASHER F436 A325 HDG	38FW844
n	2	1" FLAT WASHER F436 A325 HDG	1FWF436
o	2	1" HEX NUT A563DH HDG	1HN563
p	1	18" TO 24" LONG ZIP TIE RATED 175-200LB	ZPT18
q	1	1 1/2" X 4" SCH-40 PVC PIPE	PSPCR4
r	1	RFID CHIP RATED MIL-STD-810F	RFID810F
s	1	IMPACT HEAD REFLECTIVE SHEETING	RS30M

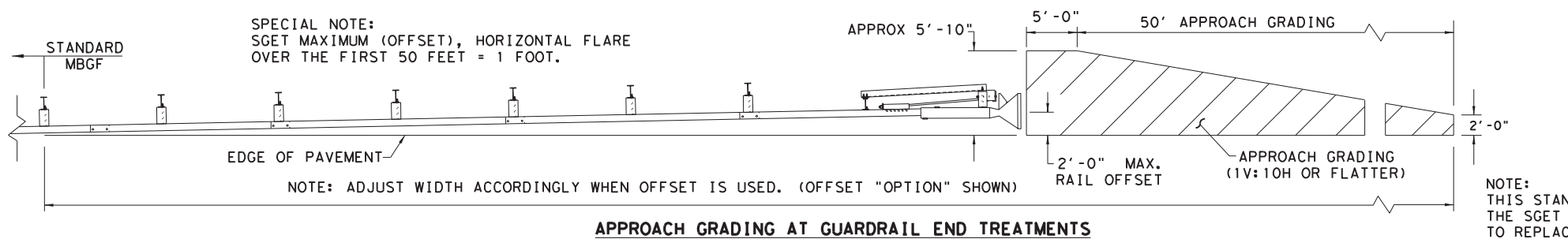
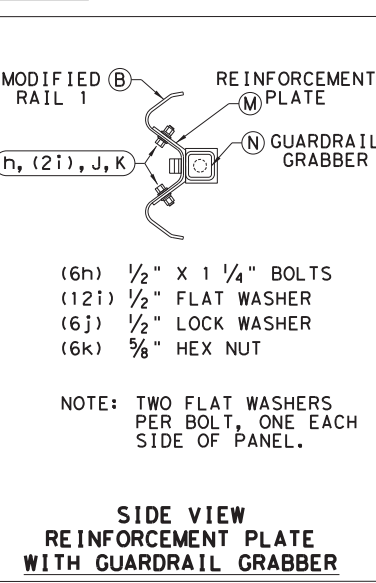
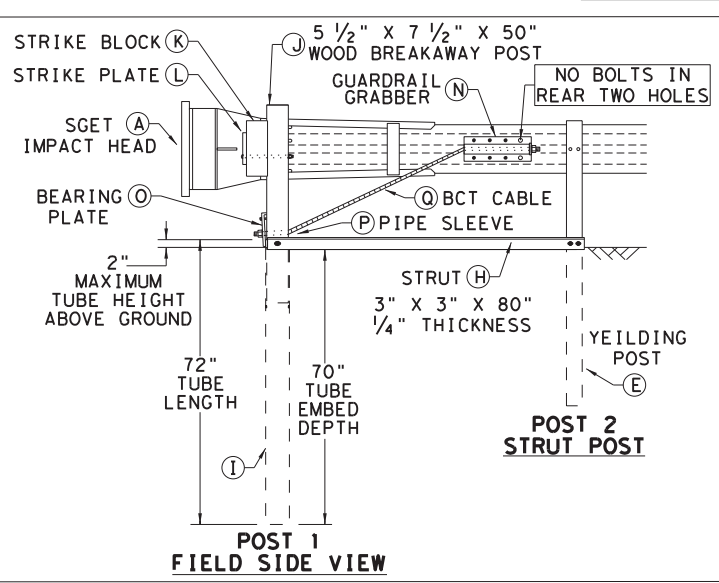
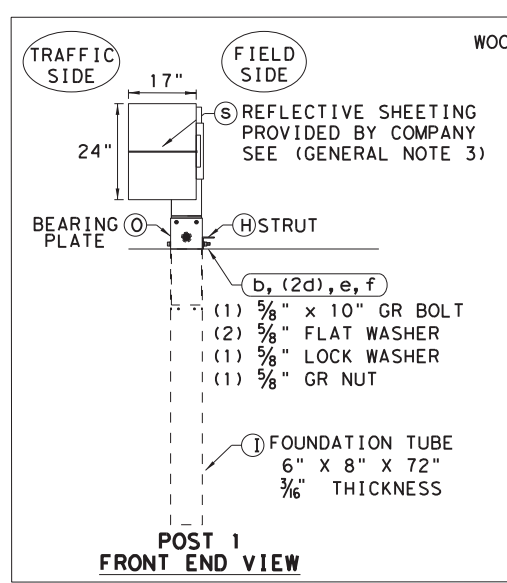
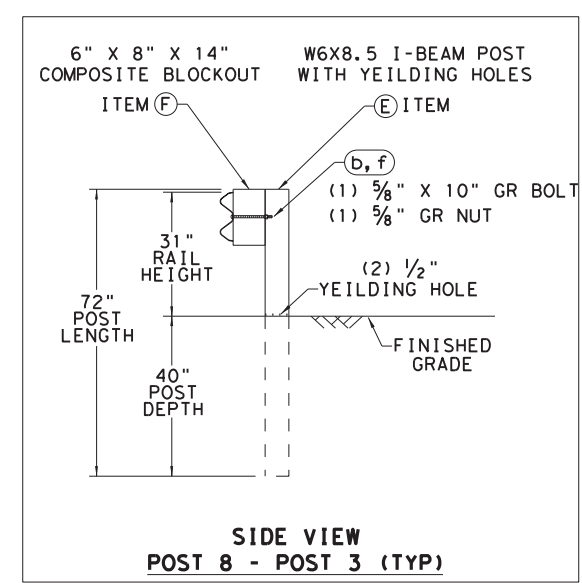

NOTE: THIS STANDARD IS A BASIC REPRESENTATION OF THE SGET TERMINAL SYSTEM AND IS NOT INTENDED TO REPLACE THE MANUFACTURER'S ASSEMBLY MANUAL.

**Texas Department of Transportation**  
Design Division Standard

**SPIG INDUSTRY, LLC**  
**SINGLE GUARDRAIL TERMINAL**  
**SGET - TL-3 - MASH**  
**SGT (15) 31-20**

FILE: sg153120.dgn	DN: TXDOT	CK: KM	DW: VP	CK: VP
© TXDOT: APRIL 2020	CONT: 6435	SECT: 38	JOB: 001	HIGHWAY: IH10, etc
REVISIONS	DIST: BMT	COUNTY: JEFFERSON, etc	SHEET NO. 60	

DATE: FILE:

DISCLAIMER: THE USE OF THIS STANDARD IS GOVERNED BY THE "TEXAS ENGINEERING PRACTICE ACT". NO WARRANTY OF ANY KIND IS MADE BY TXDOT FOR ANY PURPOSE WHATSOEVER. TXDOT ASSUMES NO RESPONSIBILITY FOR THE CONVERSION OF THIS STANDARD TO OTHER FORMATS OR FOR INCORRECT RESULTS OR DAMAGES RESULTING FROM ITS USE.

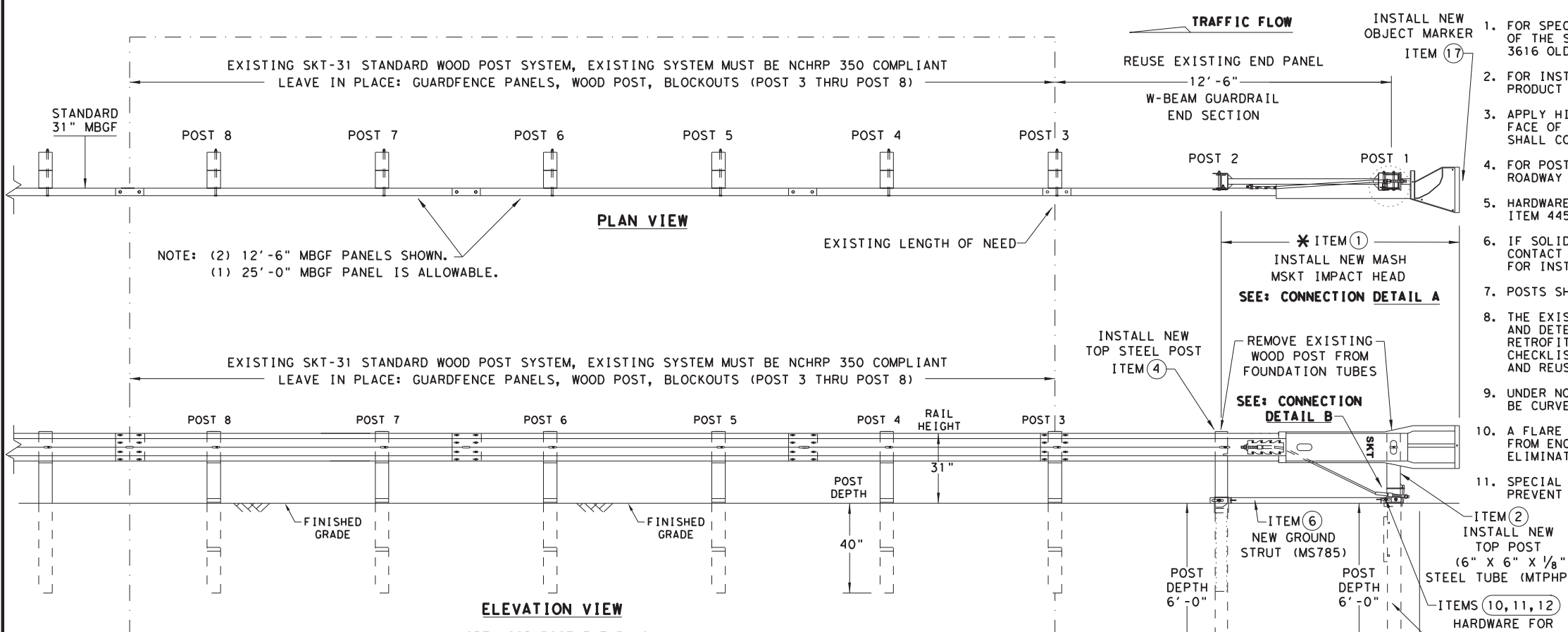

**GENERAL NOTES**

- FOR SPECIFIC INFORMATION REGARDING INSTALLATION AND TECHNICAL GUIDANCE OF THE SYSTEM, CONTACT: ROAD SYSTEMS, INC. (432)263-2435. 3616 OLD HOWARD COUNTY AIRPORT, BIG SPRING, TX 79720
- FOR INSTALLATION, REPAIR AND MAINTENANCE REFER TO: MSKT END TERMINAL, PRODUCT DESCRIPTION ASSEMBLY MANUAL (PUBLICATION-062717).
- APPLY HIGH INTENSITY REFLECTIVE SHEETING, "OBJECT MARKER" ON THE FRONT FACE OF THE DEVICE PER MANUFACTURER'S RECOMMENDATIONS. OBJECT MARKER SHALL CONFORM TO THE STANDARDS REQUIRED IN TEXAS MUTCD.
- FOR POST (LEAVE-OUT) INSTALLATION AND GUIDANCE SEE TXDOT'S LATEST ROADWAY MOW STRIP STANDARD.
- HARDWARE (BOLTS, NUTS, & WASHERS) SHALL BE GALVANIZED IN ACCORDANCE WITH ITEM 445, "GALVANIZING". FITTINGS SHALL BE SUBSIDIARY TO THE BID ITEM.
- IF SOLID ROCK IS ENCOUNTERED IN THE AREA OF (POST 1) AND / OR (POST 2) CONTACT THE MANUFACTURER, AND REFER TO THE LATEST ROADWAY MBGF STANDARD FOR INSTALLATION GUIDANCE.
- POSTS SHALL NOT BE SET IN CONCRETE.
- THE EXISTING SKT 31" STANDARD WOOD POST SYSTEM MUST BE THOROUGHLY INSPECTED, AND DETERMINED TO BE INTACT, AND FREE OF ANY DAMAGE OR DEFECTS BEFORE RETROFITTING. THIS INSPECTION INCLUDES COMPLETING THE MSKT RETROFIT INSPECTION CHECKLIST FOR THE EXISTING SKT 31" WOOD POST NCHRP 350 SYSTEM. ALL EXISTING, AND REUSABLE PARTS MUST BE FREE OF ANY DAMAGE FOR A MASH COMPLIANT RETROFIT.
- UNDER NO CIRCUMSTANCES SHALL THE GUARDRAIL WITHIN THE MSKT SYSTEM BE CURVED.
- A FLARE RATE OF UP TO 25:1 MAY BE USED TO PREVENT THE TERMINAL HEAD FROM ENCRANCHING ON THE SHOULDER. THE FLARE MAY BE DECREASED OR ELIMINATED FOR SPECIFIC INSTALLATIONS, IF DIRECTED BY THE ENGINEER.
- SPECIAL DRIVING CAP TO BE USED WHEN DRIVING (LOWER POSTS 1 & 2) TO PREVENT DAMAGE TO THE WELDED PLATES.

ITEMS	QTY	MAIN SYSTEM COMPONENTS	PART NUMBERS
1	1	MSKT IMPACT HEAD	MS3000
2	1	POST 1 - TOP (6" X 6" X 1/8" TUBE)	MTPHP1A
3	1	POST 1 - BOTTOM (6' W6X15)	MTPHP1B
4	1	POST 2 - ASSEMBLY TOP	UHP2A
5	1	POST 2 - ASSEMBLY BOTTOM (6' W6X9)	HP2B
6	1	GROUND STRUT	MS785
7	2	5/16" X 1" HEX BOLT (GRD 5)	B516014A
8	4	5/16" WASHERS	W0516
9	2	5/8" HEX NUT	N0516
10	2	5/8" X 9" HEX BOLT (GRD A449)	B580904A
11	3	5/8" WASHERS	W050
12	3	5/8" H.G.R NUT	N050
13	1	5/8" X 1 1/4" SPLICE BOLT	B580122
14	1	3/4" X 8 1/2" HEX BOLT (GRD 5)	B340854A
15	1	3/4" HEX NUT	N030
16	1	CABLE TIE-STEEL	CT-100ST
17	1	OBJECT MARKER 18" X 18"	E3151

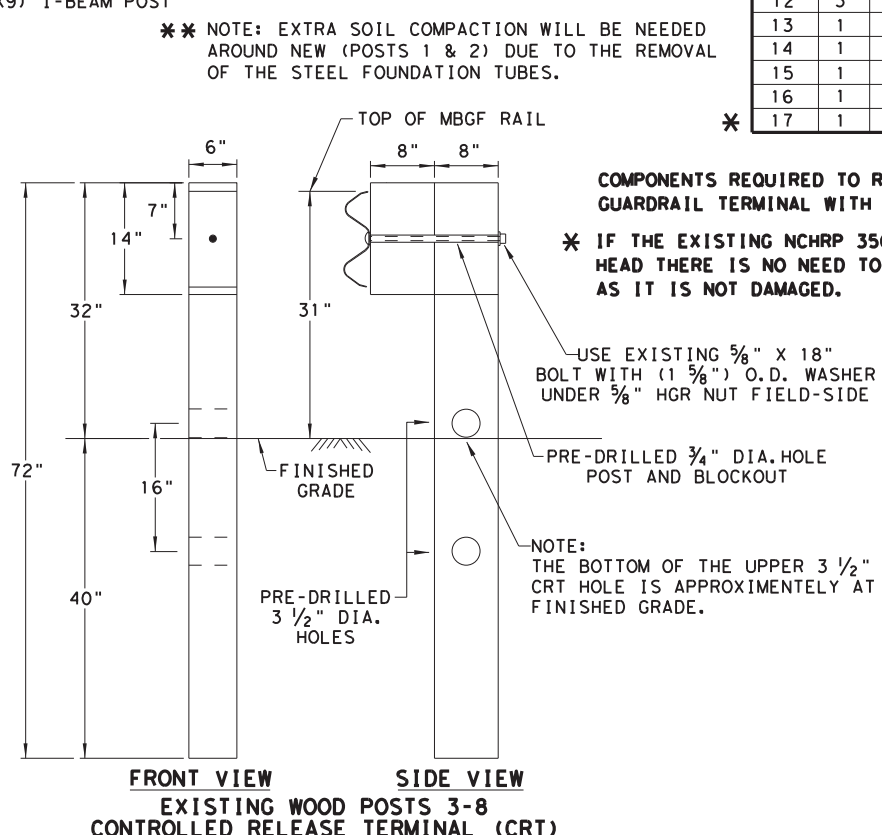
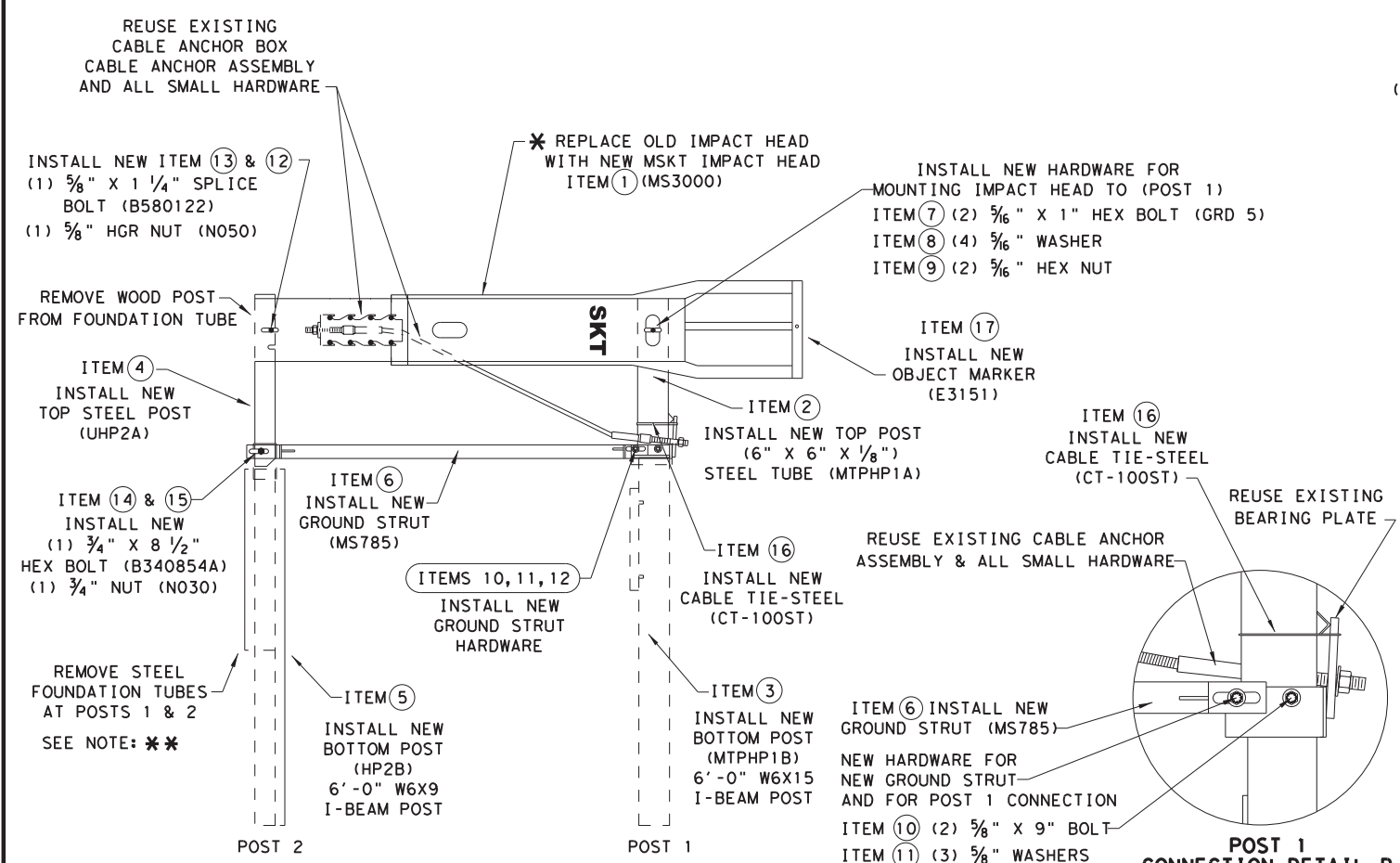

**COMPONENTS REQUIRED TO RETROFIT: EXISTING 31" WOOD POST (NCHRP 350 SKT) GUARDRAIL TERMINAL WITH THE NEW 31" (MASH COMPLIANT MSKT IMPACT HEAD).**  
 \* IF THE EXISTING NCHRP 350 (31" WOOD POST SKT) ALREADY HAS THE MSKT IMPACT HEAD THERE IS NO NEED TO REPLACE THE IMPACT HEAD OR OBJECT MARKER AS LONG AS IT IS NOT DAMAGED.



**RETROFIT STANDARD  
 SKT 31" WOOD POST SYSTEM  
 TO MASH MSKT  
 SGT (14W) 31-18**

FILE: sgt14w3118.dgn	DN: TXDOT	CK: KM	DW: VP	CK: CL
© TXDOT: APRIL 2018	CONT	SECT	JOB	HIGHWAY
REVISIONS	6435	38	001	IH10, etc
DIST	COUNTY		SHEET NO.	
BMT	JEFFERSON, etc		61	

NOTE: THIS STANDARD IS A BASIC REPRESENTATION OF THE EXISTING; SKT END TERMINAL RETROFITTED TO THE MSKT MASH COMPLIANT TERMINAL, IT IS NOT INTENDED TO REPLACE THE PRODUCT DESCRIPTION ASSEMBLY MANUAL.

DATE:  
FILE:

DISCLAIMER: The use of this standard is governed by the "Texas Engineering Practice Act". No warranty of any kind is made by TxDOT for any purpose whatsoever. TxDOT assumes no responsibility for the conversion of this standard to other formats or for incorrect results or damages resulting from its use.

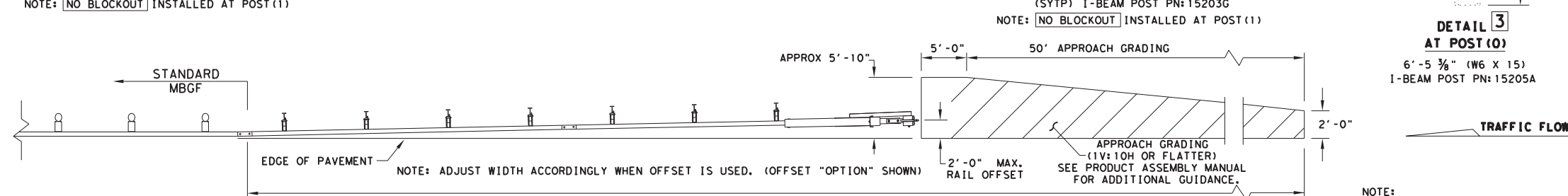
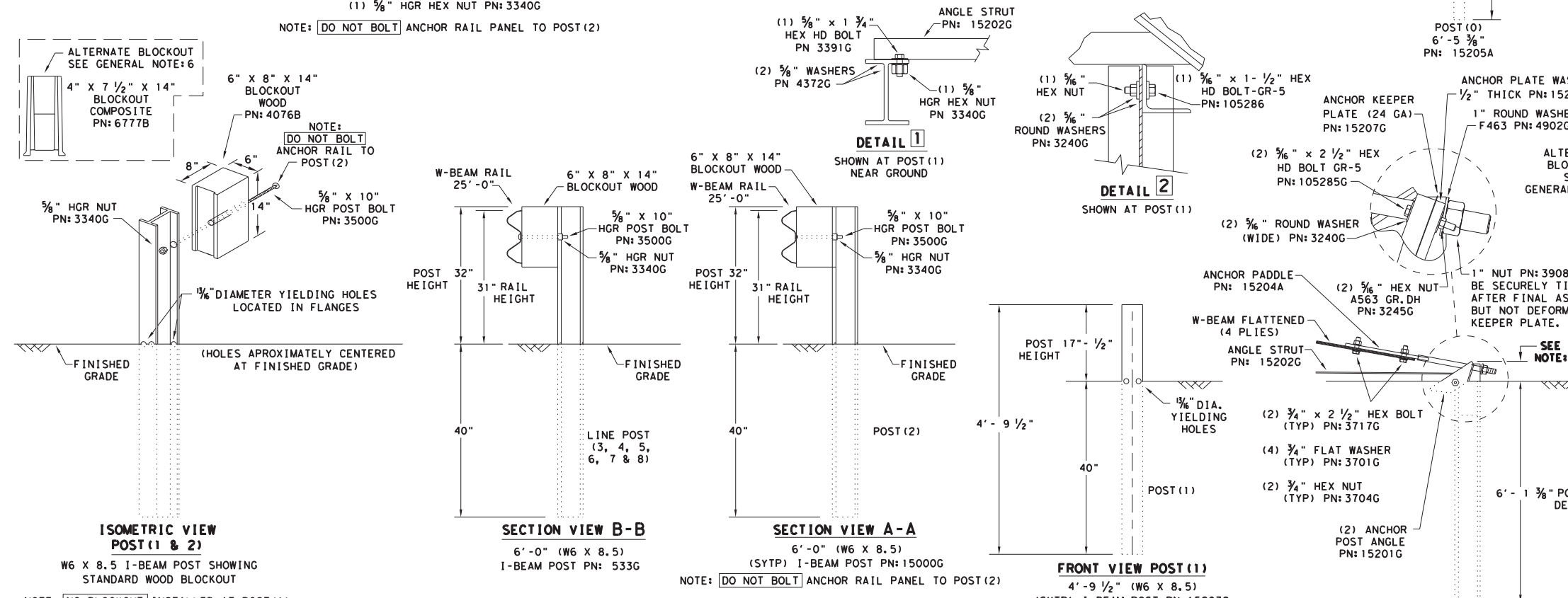
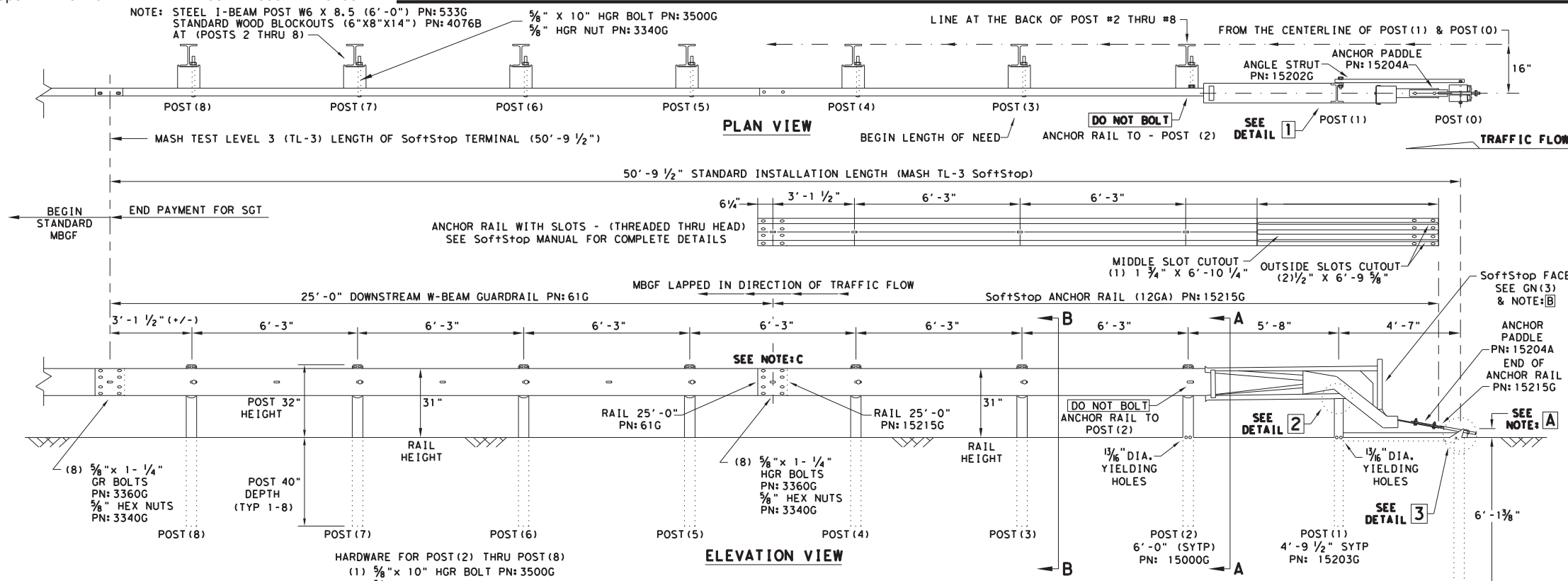

**GENERAL NOTES**

- FOR SPECIFIC INFORMATION REGARDING INSTALLATION AND TECHNICAL GUIDANCE OF THE SYSTEM, CONTACT: TRINITY HIGHWAY AT 1(888)323-6374, 2525 N. STEMMONS FREEWAY, DALLAS, TX 75207
- FOR INSTALLATION, REPAIR AND MAINTENANCE REFER TO THE: SoftStop END TERMINAL, PRODUCT DESCRIPTION ASSEMBLY MANUAL. PN:620237B
- APPLY HIGH INTENSITY REFLECTIVE SHEETING, "OBJECT MARKER" ON THE FRONT FACE OF THE DEVICE PER MANUFACTURER'S RECOMMENDATIONS. OBJECT MARKER SHALL CONFORM TO THE STANDARDS REQUIRED IN TEXAS MUTCD.
- FOR POST (LEAVE-OUT) INSTALLATION AND GUIDANCE SEE TxDOT'S LATEST ROADWAY MOW STRIP STANDARD.
- HARDWARE (BOLTS, NUTS, & WASHERS) SHALL BE GALVANIZED IN ACCORDANCE WITH ITEM 445, "GALVANIZING". FITTINGS SHALL BE SUBSIDIARY TO THE BID ITEM.
- A COMPOSITE MATERIAL BLOCKOUT THAT MEETS THE REQUIREMENTS OF DMS-7210, MAY BE SUBSTITUTED FOR BLOCKOUTS OF SIMILAR DIMENSIONS. SEE CONSTRUCTION DIVISION MATERIAL PRODUCER LIST (MPL) FOR CERTIFIED PRODUCERS.
- IF SOLID ROCK IS ENCOUNTERED SEE THE MANUFACTURER'S INSTALLATION MANUAL AND REFER TO THE LATEST ROADWAY MGBF STANDARD FOR INSTALLATION GUIDANCE.
- POSTS SHALL NOT BE SET IN CONCRETE.
- IT IS ACCEPTABLE TO INSTALL THE SoftStop IMPACT HEAD PARALLEL TO THE GRADE LINE OR WITH AN UPWARD TILT.
- DO NOT ATTACH THE SoftStop SYSTEM DIRECTLY TO A RIGID BARRIER.
- UNDER NO CIRCUMSTANCES SHALL THE GUARDRAIL WITHIN THE SoftStop SYSTEM BE CURVED.
- A FLARE RATE OF UP TO 25:1 MAY BE USED TO PREVENT THE TERMINAL HEAD FROM ENCRoaching ON THE SHOULDER. THE FLARE MAY BE DECREASED OR ELIMINATED FOR SPECIFIC INSTALLATIONS, IF DIRECTED BY THE ENGINEER.

<b>NOTE: A</b>	THE INSTALLATION HEIGHT OF FULLY ASSEMBLED ANCHOR POST WILL VARY FROM 3-3/4" MIN. TO 4" MAX. ABOVE FINISHED GRADE.
<b>NOTE: B</b>	PART PN:5852B RIGHT-SIDE (HIGH INTENSITY REFLECTIVE SHEETING) PART PN:5851B LEFT-SIDE (HIGH INTENSITY REFLECTIVE SHEETING)
<b>NOTE: C</b>	W-BEAM SPLICE LOCATED BETWEEN LINE POST(4) AND LINE POST(5) GUARDRAIL PANEL 25'-0" PN:61G ANCHOR RAIL 25'-0" PN:15215G LAP GUARDRAIL IN DIRECTION OF TRAFFIC FLOW.

PART	QTY	MAIN SYSTEM COMPONENTS
620237B	1	PRODUCT DESCRIPTION ASSEMBLY MANUAL (LATEST REV.)
15208A	1	SoftStop HEAD (SEE MANUAL FOR RIGHT-LEFT APPROACH)
15215G	1	SoftStop ANCHOR RAIL (12GA) WITH CUTOUT SLOTS
61G	1	SoftStop DOWNSTREAM W-BEAM RAIL (12GA) (25' - 0")
15205A	1	POST #0 - ANCHOR POST (6' - 5 3/8")
15203G	1	POST #1 - (SYTP) (4' - 9 1/2")
15000G	1	POST #2 - (SYTP) (6' - 0")
533G	6	POST #3 THRU #8 - I-BEAM (W6 X 8.5) (6' - 0")
4076B	7	BLOCKOUT - WOOD (ROUTED) (6" X 8" X 14")
6777B	7	BLOCKOUT - COMPOSITE (4" X 7 1/2" X 14")
15204A	1	ANCHOR PADDLE
15207G	1	ANCHOR KEEPER PLATE (24 GA)
15206G	1	ANCHOR PLATE WASHER (1/2" THICK)
15201G	2	ANCHOR POST ANGLE (10" LONG)
15202G	1	ANGLE STRUT

HARDWARE		
4902G	1	1" ROUND WASHER F436
3908G	1	1" HEAVY HEX NUT A563 GR.DH
3717G	2	3/4" X 2 1/2" HEX BOLT A325
3701G	4	3/4" ROUND WASHER F436
3704G	2	3/4" HEAVY HEX NUT A563 GR.DH
3360G	16	5/8" X 1 1/4" W-BEAM RAIL SPLICE BOLTS HGR
3340G	25	5/8" W-BEAM RAIL SPLICE NUTS HGR
3500G	7	5/8" X 10" HGR POST BOLT A307
3391G	1	5/8" X 1 3/4" HEX HD BOLT A325
4489G	1	5/8" X 9" HEX HD BOLT A325
4372G	4	5/8" WASHER F436
105285G	2	5/8" X 2 1/2" HEX HD BOLT GR-5
105286G	1	5/8" X 1 1/2" HEX HD BOLT GR-5
3240G	6	5/8" ROUND WASHER (WIDE)
3245G	3	5/8" HEX NUT A563 GR.DH
5852B	1	HIGH INTENSITY REFLECTIVE SHEETING - SEE NOTE: B



**TRINITY HIGHWAY**  
**SOFTSTOP END TERMINAL**  
**MASH - TL-3**  
**SGT (10S) 31-16**

FILE: sgt10s3116	DW: TxDOT	CR: KM	DW: VP	CR: MB/VP
© TxDOT: JULY 2016	CONT	SECT	JOB	HIGHWAY
REVISIONS	6435	38	001	IHTO, etc
	DIST	COUNTY		SHEET NO.
	BMT	JEFFERSON, etc		62

NOTE:  
 THIS STANDARD IS A BASIC REPRESENTATION OF THE SoftStop END TERMINAL. IT IS NOT INTENDED TO REPLACE THE PRODUCT DESCRIPTION ASSEMBLY MANUAL.

DATE:  
FILE:

DISCLAIMER: THIS STANDARD IS GOVERNED BY THE "TEXAS ENGINEERING PRACTICE ACT". NO WARRANTY OF ANY KIND IS MADE BY TXDOT FOR ANY PURPOSE WHATSOEVER. TXDOT ASSUMES NO RESPONSIBILITY FOR THE CONVERSION OF THIS STANDARD TO OTHER FORMATS OR FOR INCORRECT RESULTS OR DAMAGES RESULTING FROM ITS USE.

**QUADGUARD ELITE M10 69" WIDE (8 BAY) SYSTEM**

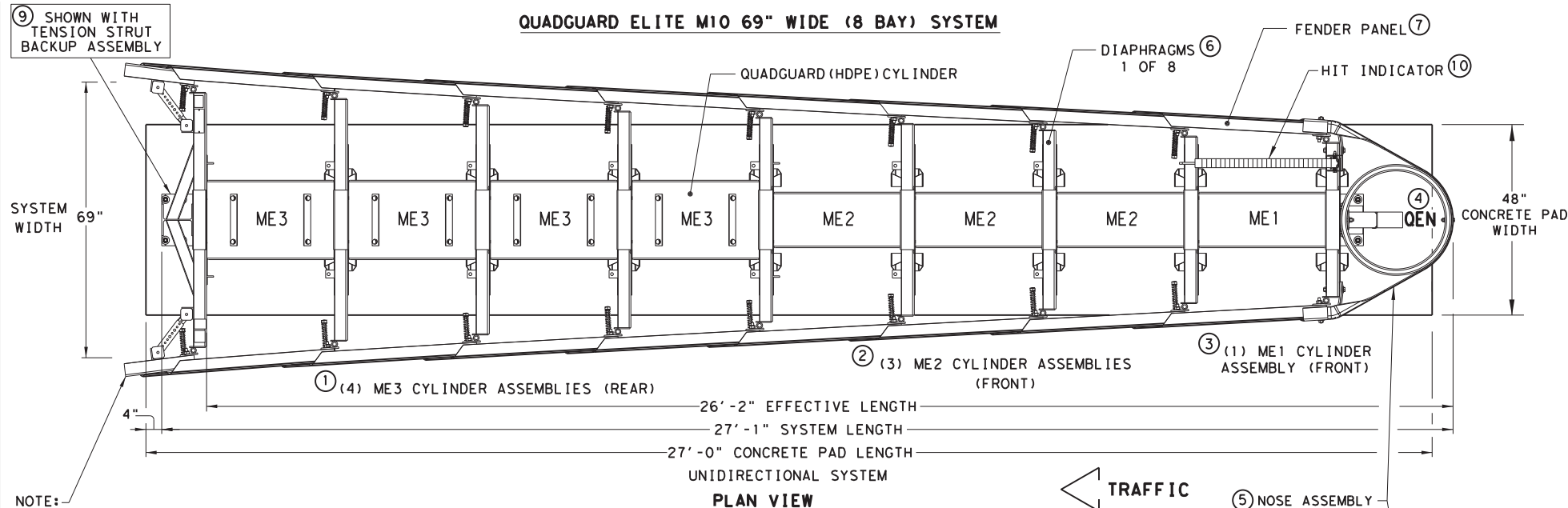

NOTE:  
A TRANSITION MAY BE REQUIRED TO INSTALL THE QUADGUARD ELITE M10 TO THE OBJECT BEING SHIELDED.

KEY	KEY
① ME3 CYLINDER ASSEMBLIES	⑥ DIAPHRAGMS
② ME2 CYLINDER ASSEMBLIES	⑦ FENDER PANELS
③ ME1 CYLINDER ASSEMBLY	⑧ MONORAILS
④ QEN CYLINDER	⑨ TYPE OF BACKUP
⑤ NOSE BELT ASSEMBLY	⑩ HIT INDICATOR

NOTE:  
HIT INDICATOR WILL RAISE UPON IMPACT.

NOTE:  
PROVISION SHALL BE MADE FOR REAR FENDER SIDE PANELS TO SLIDE REARWARD UPON IMPACT, 30" MIN.

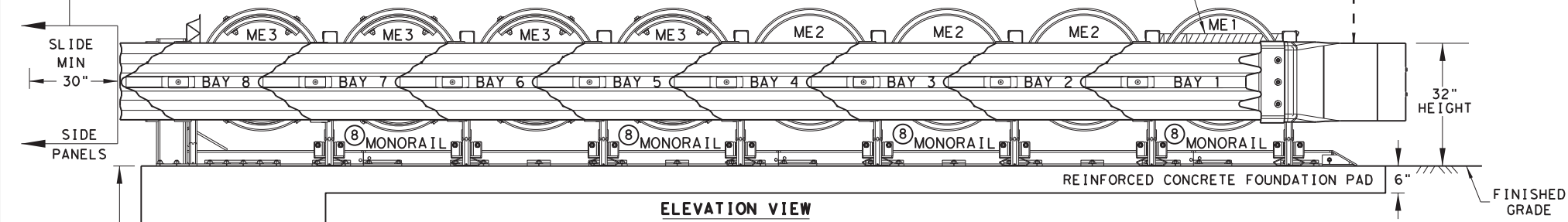

NOTES:  
CONTACT THE MANUFACTURER WITH SITE SPECIFIC DATA (SSD) FOR CONCRETE PAD AND ANCHOR BLOCK INSTALLATION REQUIREMENTS.

A MANUFACTURER'S DRAWING PACKAGE UNIQUE AND SPECIFIC FOR THE QUADGUARD ELITE WIDE M10 FIELD INSTALLATION AND INFORMATION REGARDING THE TYPE OF BACKUP ASSEMBLY REQUIRED FOR THE TRANSITION WILL BE PROVIDED BY THE MANUFACTURER TO THE ENGINEER AND INSTALLER.

6" REINFORCED CONCRETE PAD REQUIRES THE INSTALLATION OF AN ANCHOR BLOCK AS SHOWN ON THE MANUFACTURER'S DRAWING PACKAGE.

8" NON-REINFORCED CONCRETE PAD MAY NOT REQUIRE AN ANCHOR BLOCK, IF THE PAD IS INSTALLED AGAINST AN IMMOVABLE CONCRETE BACKUP.

CONCRETE PAD AND ANCHOR BLOCK COMBINATIONS SHALL BE CONFIRMED WITH THE MANUFACTURER BASED UPON SITE SPECIFIC DATA (SSD).

NOTE:  
THE QUADGUARD ELITE M10 WIDE 8-BAY SYSTEM TESTED TO MASH TEST LEVEL 3.

TL-3 MODEL #	QM10069E	CYLINDER TYPES IN BAYS			
BAYS	8	TYPE-ME3	TYPE-ME2	TYPE-ME1	TYPE-QEN
DIAPHRAGMS	8	4	3	1	1
WIDTH	69"	REAR	FRONT	NOSE	

**ELEVATION VIEW LEFT SIDE**

**BACKUP ASSEMBLY TYPES FOR SYSTEM TRANSITIONS**

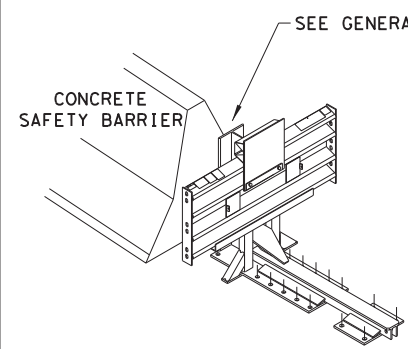

**⑨ TENSION STRUT BACKUP**

NOTES:  
CONTACT THE MANUFACTURER WITH SITE SPECIFIC DATA (SSD) FOR THE CORRECT BACKUP ASSEMBLY AND TRANSITION PANELS OR SIDE PANELS USED FOR STANDARD AND BI-DIRECTIONAL INSTALLATIONS: AT DIVIDED-HIGHWAY MEDIANS OR UNDIVIDED ROADWAYS WHERE THE SYSTEM IS EXPOSED TO IMPACTS FROM ONE OR TWO DIFFERENT DIRECTIONS OF TRAFFIC FLOW.

SYSTEM TRANSITIONS TYPES	
1	QUAD-BEAM TO CONCRETE SAFETY BARRIER
2	QUAD-BEAM TO CONCRETE BRIDGE RAIL
3	QUAD-BEAM TO SINGLE SLOPE OFFSET
4	QUAD-BEAM TO CONCRETE END SHOE
5	QUAD-BEAM TO THRIE-BEAM RAIL
6	QUAD-BEAM TO W-BEAM RAIL

NOTE:  
TRANSITION ASSEMBLIES FOR THE QUADGUARD ELITE M10 TO THRIE-BEAM OR W-BEAM FENCE REQUIRES I-BEAM POSTS:  
ALL POSTS W6X8.5/9 I-BEAMS (78" LONG).

NOTE:  
THIS STANDARD IS A BASIC REPRESENTATION OF THE QUADGUARD ELITE M10 WIDE SYSTEM AND IS NOT INTENDED TO REPLACE THE PRODUCT DESCRIPTION ASSEMBLY MANUAL.

**GENERAL NOTES**

- FOR SPECIFIC INFORMATION REGARDING INSTALLATION AND TECHNICAL GUIDANCE OF THE SYSTEM, CONTACT: TRINITY HIGHWAY - ENERGY ABSORPTION INC. AT 1(888)323-6374.
- SEE THE RECENT QUADGUARD ELITE M10 WIDE PRODUCT DESCRIPTION ASSEMBLY MANUAL FOR IMPACT PERFORMANCE CHARACTERISTICS AND DESIGN LIMITATIONS AND THE DRAWING PACKAGE FOR THE WIDE 69" SYSTEM BEFORE INSTALLING THE QUADGUARD ELITE M10 AT ANY GIVEN LOCATION.
- FOR BI-DIRECTIONAL TRAFFIC: THE LOCATION AND OR WIDTH OF THE QUADGUARD ELITE M10 WIDE 69" IS RESTRICTED. AS BI-DIRECTIONAL TRAFFIC APPROACHES THE REAR OF THE QUADGUARD ELITE M10 WIDE 69", THE QUADGUARD ELITE M10 SHOULD NOT EXTEND FURTHER INTO THE TRAFFIC-SIDE OF THE BARRIER THAN THE OBSTACLE. ANY TRANSITION INSTALLED MUST EITHER BE TANGENT TO BOTH QUADGUARD ELITE M10 AND OBSTACLE OR MUST ANGLE TOWARD FIELD SIDE OF THE BARRIER.
- SYSTEM TRANSITION: APPROPRIATE TRANSITION PANELS OR SIDE PANELS WILL BE REQUIRED FOR PROPER IMPACT PERFORMANCE. THE CORRECT PANEL(S) TO USE WILL DEPEND ON THE DIRECTION OF TRAFFIC FLOW AND WHAT TYPE OF BARRIER OR ROAD FEATURE THE QUADGUARD ELITE M10 SYSTEM IS SHIELDING. SEE THE QUADGUARD ELITE M10 WIDE [69"] PRODUCT DESCRIPTION & ASSEMBLY MANUAL FOR FURTHER DETAILS.
- COMPONENTS FOR THE QUADGUARD ELITE (M10) BACKUP AND REINFORCING DETAILS ARE SHOWN ON THE QUADGUARD ELITE M10 WIDE PRODUCT DESCRIPTION & ASSEMBLY MANUAL.
- CONCRETE PAD SHALL BE 6" MIN. REINFORCED 28MPa [4,000 PSI] (P.C.) OR 8" MIN. NON-REINFORCED 28MPa [4,000 PSI] CONCRETE ROADWAY MEASURING AT LEAST 12'-0" WIDE BY 50'-0" LONG. ANCHOR BLOCK IS NOT REQUIRED WHEN USING 8" CONCRETE PAD INSTALLED AGAINST AN IMMOVABLE STRUCTURE, E.G. CONCRETE WALL.
- IF THE CROSS-SLOPE VARIES MORE THAN 2% OVER THE LENGTH OF THE SYSTEM, THE CONCRETE PAD WILL REQUIRE LEVELING. MAXIMUM PERMISSIBLE CROSS-SLOPE IS 8%.
- THE INSTALLATION AREA SHOULD BE FREE OF CURBS, ELEVATED OBJECTS, OR DEPRESSIONS.
- THE QUADGUARD ELITE M10 SYSTEM SHOULD BE INSTALLED APPROXIMATELY PARALLEL WITH THE BARRIER.
- FOR THE TENSION STRUT BACKUP, THE DISTANCE BETWEEN THE BACK OF BACKUP AND THE BARRIER WALL SHOULD NOT EXCEED 7" IN ANY CASE.
- THE WIDE QUADGUARD ELITE M10 SYSTEM IS ONLY AVAILABLE IN A 69" WIDTH.

**FOUNDATION & ANCHORING REQUIREMENTS FOUNDATION TYPES: A, B, C, & D**

FOUNDATION TYPE:A	REINFORCED CONCRETE PAD OR ROADWAY
FOUNDATION:	6" MINIMUM DEPTH (P.C.C.)
ANCHORAGE:	7" STUDS EMBEDDED 5 1/2" - APPROVED ADHESIVE
FOUNDATION TYPE:B	ASPHALT OVER P.C.C.
FOUNDATION:	3" MIN. (A.C.) OVER 3" MIN. (P.C.C.)
ANCHORAGE:	18" THREADED ROD EMBEDDED 16 1/2" - APPROVED ADHESIVE
FOUNDATION TYPE:C	ASPHALT OVER SUBBASE
FOUNDATION:	6" MIN. (A.C.) OVER 6" MIN. (C.S.)
ANCHORAGE:	18" THREADED ROD EMBEDDED 16 1/2" - APPROVED ADHESIVE
FOUNDATION TYPE:D	ASPHALT ONLY
FOUNDATION:	8" MIN. (A.C.)
ANCHORAGE:	18" THREADED ROD EMBEDDED 16 1/2" - APPROVED ADHESIVE

KEY:  
ASPHALT CONCRETE (A.C.)  
COMPACTED SUBBASE (C.S.)  
PORTLAND CEMENT CONCRETE (P.C.C.)

NOTE: SEE TRINITY'S PRODUCT DESCRIPTION ASSEMBLY MANUAL FOR THE APPROVED ADHESIVE.

IF THE UNIT IS ANCHORED TO ASPHALTIC CONCRETE, IT SHOULD BE RELOCATED TO FRESH, UNDISTURBED ASPHALT AND RE-ANCHORED AFTER EACH IMPACT TO ENSURE ADEQUATE FUTURE PERFORMANCE.

TENSION STRUT BACKUP MAY BE USED IN CONSTRUCTION ZONES ON ASPHALT CONCRETE (A.C.) FOR TEMPORARY USE ONLY.

Design Division Standard

TRINITY HIGHWAY  
 ENERGY ABSORPTION  
 QUADGUARD ELITE M10 WIDE  
 (MASH TL-3)  
 QGELITE (M10) (W) -20

FILE: qgel1tem10w20.dgn	DN: TXDOT	CK: KM	DW: SS	CK: AG
© TXDOT: NOVEMBER 2020	CONT	SECT	JOB	HIGHWAY
REVISIONS	6435	38	001	IH10, etc
DIST	COUNTY		SHEET NO.	
BMT	JEFFERSON, etc		63	

**LOW MAINTENANCE**

DATE:  
FILE:

DISCLAIMER: The use of this standard is governed by the "Texas Engineering Practice Act". No warranty of any kind is made by TxDOT for any purpose whatsoever. TxDOT assumes no responsibility for the conversion of this standard to other formats or for incorrect results or damages resulting from its use.

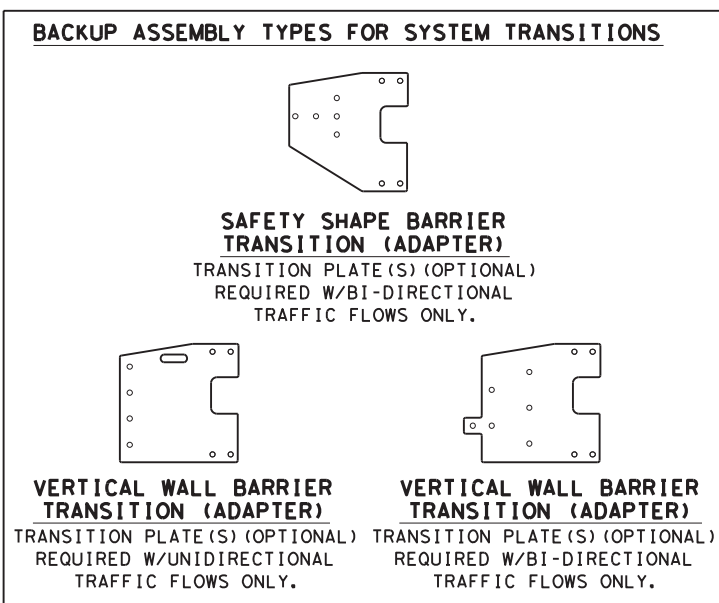
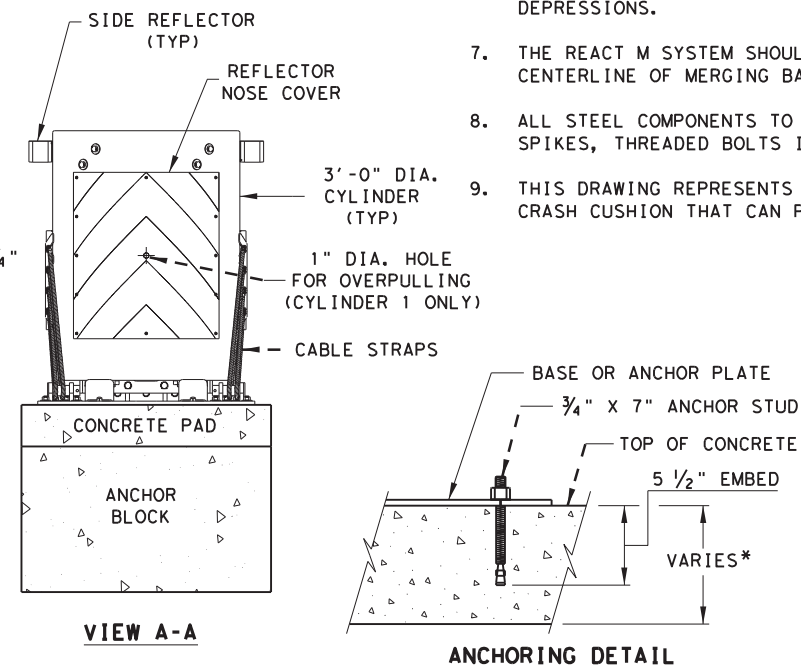
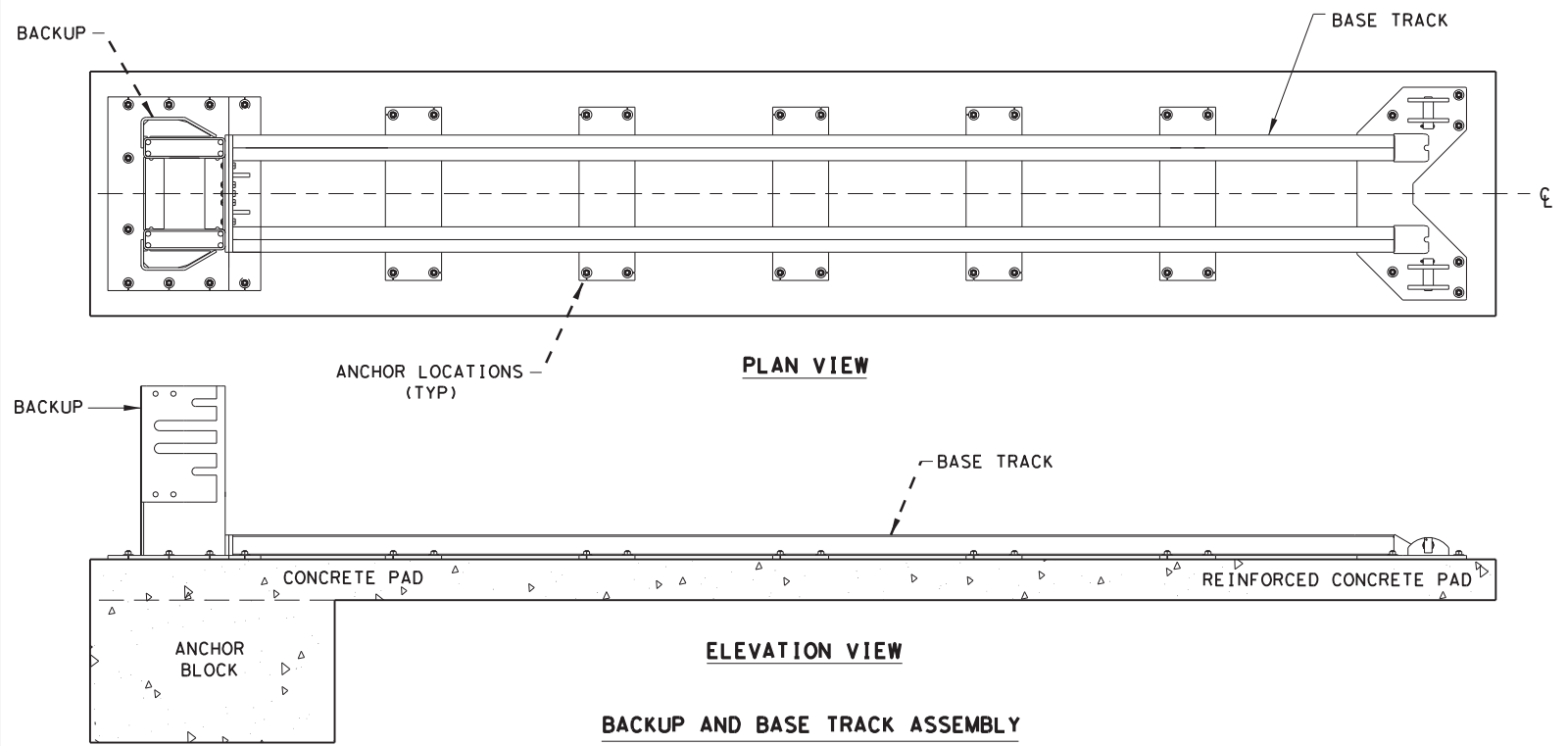
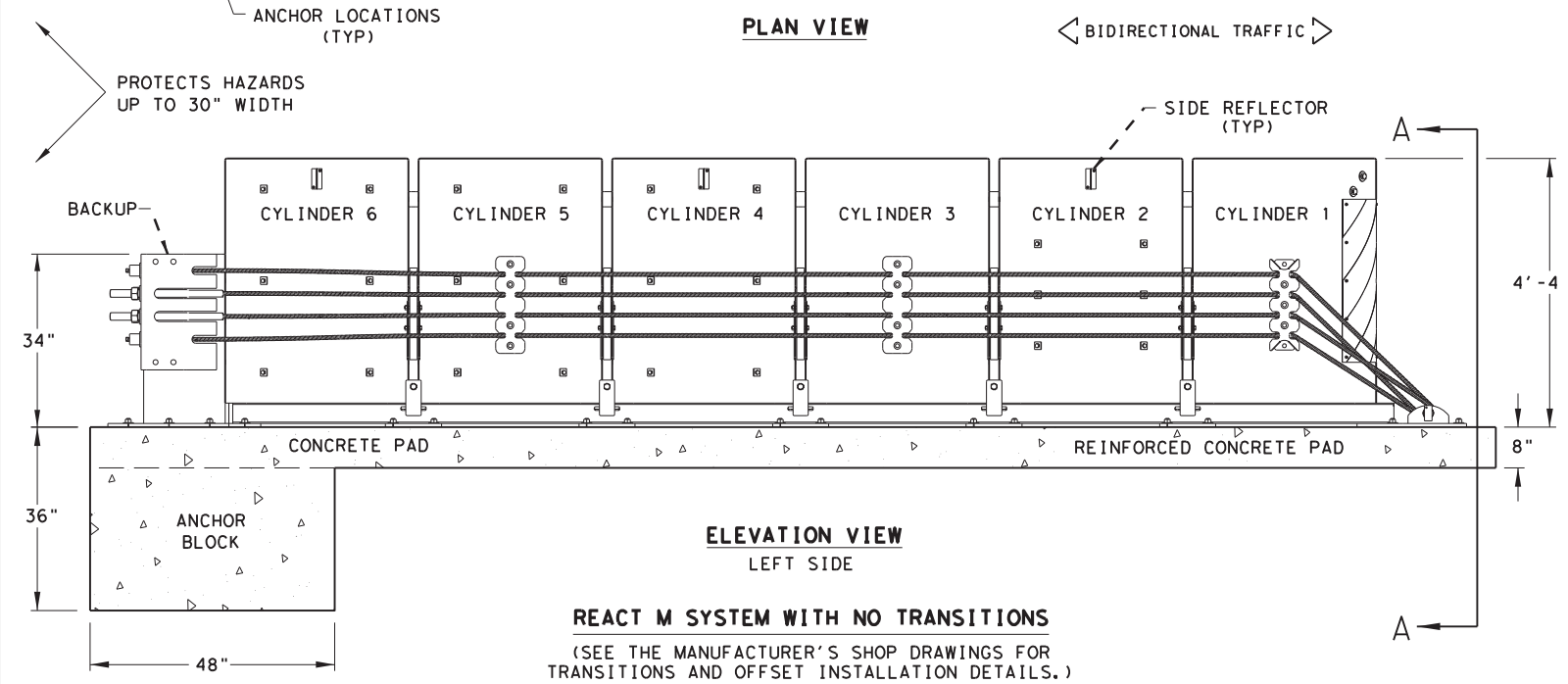
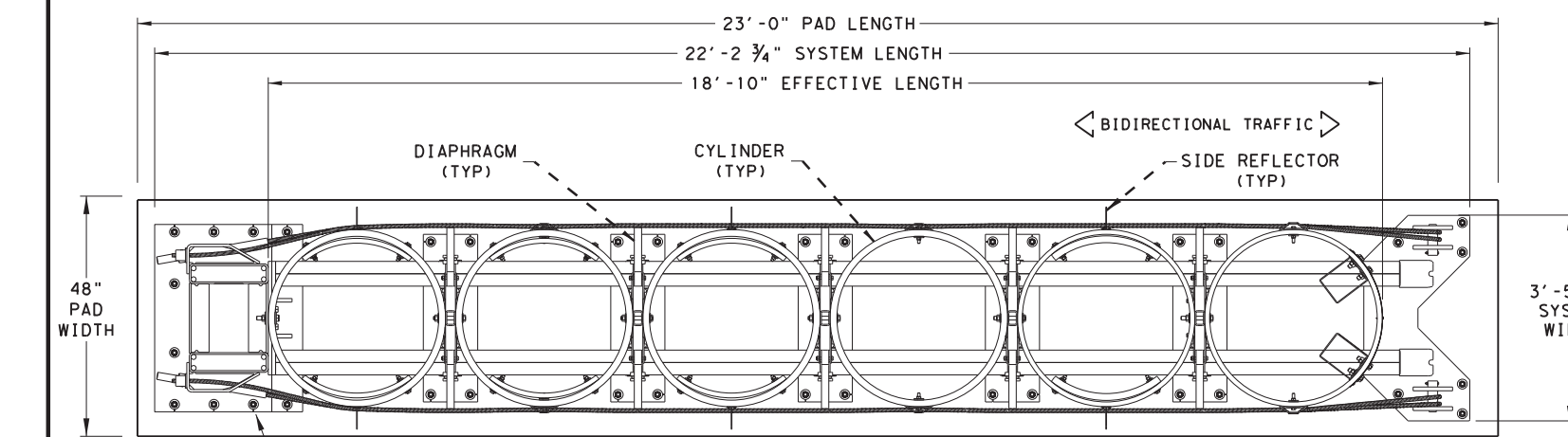

NOTES:  
CONTACT THE MANUFACTURER WITH SITE SPECIFIC DATA (SSD) FOR THE CORRECT BACKUP ASSEMBLY AND TRANSITION PANELS OR SIDE PANELS USED FOR STANDARD AND BI-DIRECTIONAL INSTALLATIONS: AT DIVIDED-HIGHWAY MEDIANS OR UNDIVIDED ROADWAYS WHERE THE SYSTEM IS EXPOSED TO IMPACTS FROM ONE OR TWO DIFFERENT DIRECTIONS OF TRAFFIC FLOW.

**GENERAL NOTES**

- FOR SPECIFIC INFORMATION REGARDING INSTALLATION AND TECHNICAL GUIDANCE OF THE SYSTEM, CONTACT: TRINITY HIGHWAY - ENERGY ABSORPTION AT 1(888)323-6374 OR WEBSITE: [www.trinityhighway.com](http://www.trinityhighway.com).
- THE NOSE OF THE REACT M SHALL BE CLAD WITH A PLASTIC WRAP WITH STANDARD DELINEATION ADHERED TO THE WRAP AND SHALL HAVE A SERIES OF SIDE MARKER REFLECTORS ON BOTH SIDES OF THE UNIT. SEE SITE PLAN VIEWS FOR MARKER AND PLASTIC WRAP COLOR ORIENTATION.
- FOR BI-DIRECTIONAL TRAFFIC, APPROPRIATE TRANSITION DETAILS WILL BE AS SHOWN ON THE MANUFACTURER'S SHOP DRAWINGS.
- DETAILS OF COMPONENTS FOR THE REACT M, BACKUPS AND REINFORCING DETAILS WILL BE SHOWN ON THE MANUFACTURER'S SHOP DRAWINGS FURNISHED TO THE ENGINEER.
- IF THE CROSS-SLOPE VARIES MORE THAN 2% OVER THE LENGTH OF THE SYSTEM, THE CONCRETE PAD WILL REQUIRE LEVELING. MAXIMUM PERMISSIBLE CROSS-SLOPE IS 8%.
- THE INSTALLATION AREA SHOULD BE FREE FROM CURBS, ELEVATED OBJECTS, OR DEPRESSIONS.
- THE REACT M SYSTEM SHOULD BE APPROXIMATELY PARALLEL WITH THE BARRIER OR CENTERLINE OF MERGING BARRIERS.
- ALL STEEL COMPONENTS TO BE HOT DIPPED GALVANIZED EXCEPT STAKES, DRIVE SPIKES, THREADED BOLTS IN BACKUP UNIT, AND WEDGE FITTINGS ON CABLES.
- THIS DRAWING REPRESENTS THE REACT M TL-3 SYSTEM, RE-DIRECTIVE, NON-GATING CRASH CUSHION THAT CAN PROTECT HAZARDS UP TO 30-INCHES IN WIDTH.

TEST NUMBER	TEST LEVEL	OVERALL LENGTH	TRANSITION LENGTH	SYSTEM WIDTH
3-30 To 3-36	TL-3	22'-2 3/4"	-	3'-5 3/4"
3-37A	TL-3	22'-2 3/4"	9'-10 3/4"	3'-5 3/4"
3-38	TL-3	22'-2 3/4"	-	3'-5 3/4"

ANCHOR SYSTEM TYPE
APPROVED ADHESIVE, 7" STUDS, 5.5" EMBEDMENT

FOUNDATION TYPES
MINIMUM 8" REINFORCED PORTLAND CEMENT CONCRETE PAD (REQUIRED REINFORCING STEEL FOR CONCRETE PAD SHALL BE SHOWN ON THE MANUFACTURER'S SHOP DRAWINGS.)
MINIMUM 8" NON-REINFORCED PORTLAND CEMENT CONCRETE ROADWAY MEASURING AT LEAST 12' WIDE BY 50' LONG)
MINIMUM 7" CONCRETE DECK STRUCTURE, OR MINIMUM 6" REINFORCED CONCRETE ROADWAY

NOTE:  
THIS STANDARD IS A BASIC REPRESENTATION OF THE REACT M SYSTEM AND IS NOT INTENDED TO REPLACE THE PRODUCT DESCRIPTION ASSEMBLY MANUAL.

Design Division Standard

## TRINITY HIGHWAY ENERGY ABSORPTION CRASH CUSHION REACT M (NARROW) (MASH TL-3) REACT (M) -21

FILE: reactm21.dgn	DN: TxDOT	CK: KM	DW: SS	CK: CL
© TxDOT: JULY 2021	CONT	SECT	JOB	HIGHWAY
REVISIONS	6435	38	001	IH10, etc
DIST	COUNTY		SHEET NO.	
BMT	JEFFERSON, etc		64	

**LOW MAINTENANCE**

DATE:  
FILE:



DISCLAIMER: The use of this standard is governed by the "Texas Engineering Practice Act". No warranty of any kind is made by TxDOT for any purpose whatsoever. TxDOT assumes no responsibility for the conversion of this standard to other formats or for incorrect results or damages resulting from its use.

**QUADGUARD M WIDE (69") (6 BAY) SYSTEM**

BIDIRECTIONAL TRAFFIC

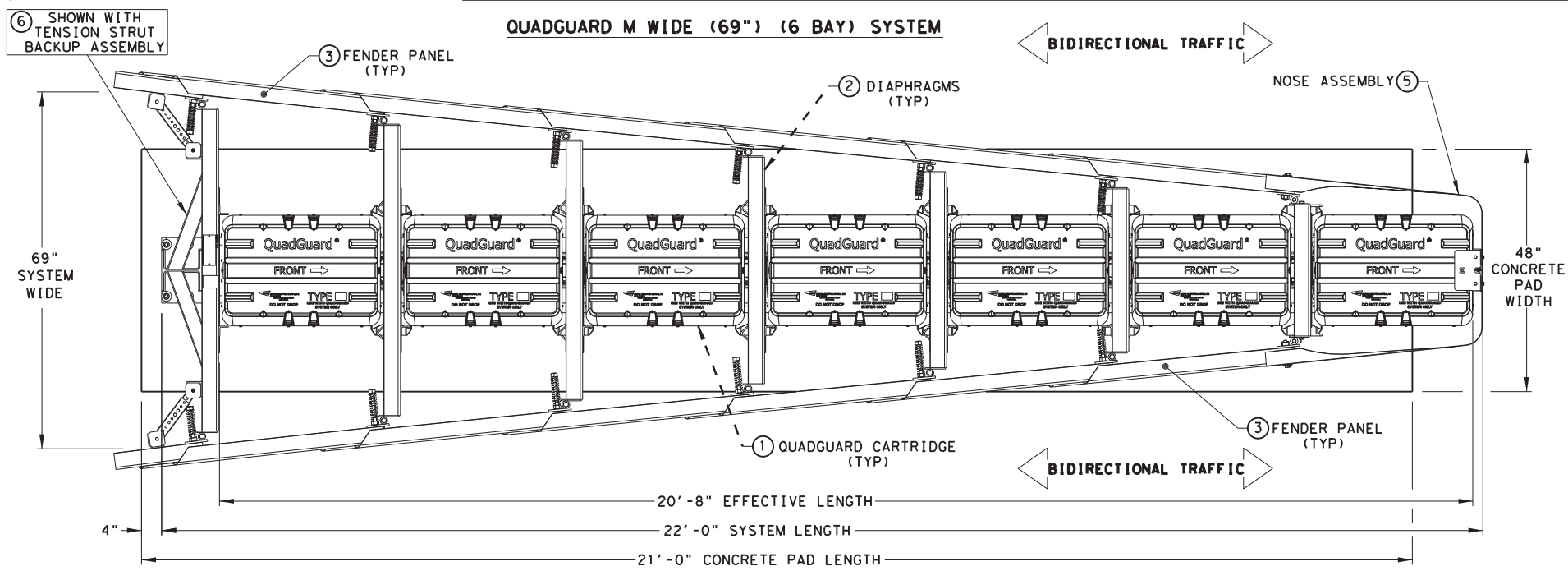

**PLAN VIEW**

KEY	DESCRIPTION	KEY	DESCRIPTION
①	QUADGUARD CARTRIDGE	⑤	NOSE ASSEMBLY
②	DIAPHRAGM	⑥	TYPE OF BACKUP
③	FENDER PANEL	⑦	REINFORCED CONCRETE FOUNDATION PAD
④	MONORAIL		

NOTE: PROVISION SHALL BE MADE FOR REAR FENDER SIDE PANELS TO SLIDE REARWARD UPON IMPACT, 30" MIN.

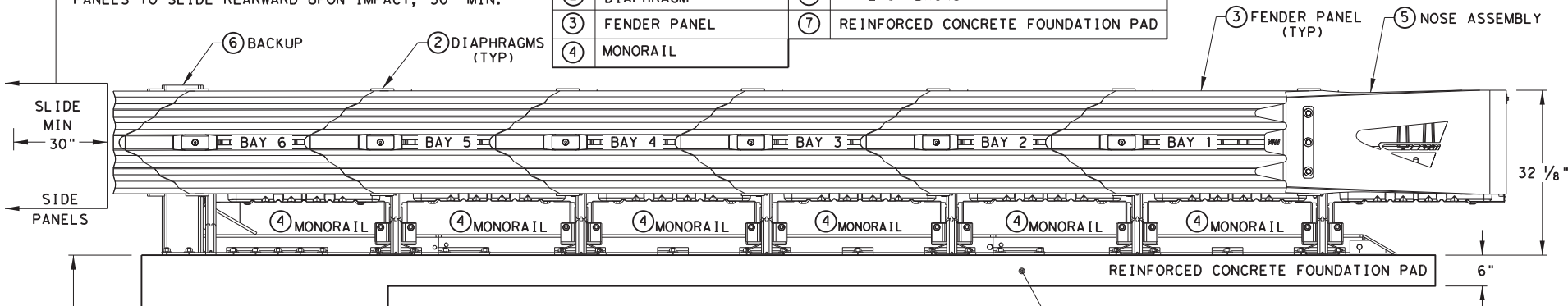

**ELEVATION VIEW  
LEFT SIDE**

**BACKUP ASSEMBLY TYPES FOR SYSTEM TRANSITIONS**

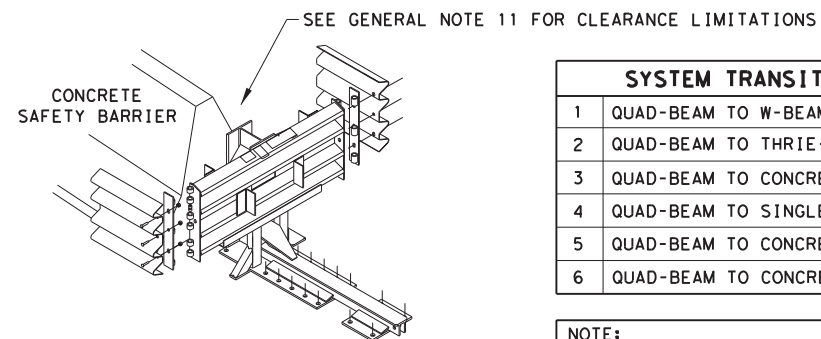

**⑥ TENSION STRUT BACKUP**

SYSTEM TRANSITIONS TYPES	
1	QUAD-BEAM TO W-BEAM RAIL
2	QUAD-BEAM TO THRIE-BEAM RAIL
3	QUAD-BEAM TO CONCRETE SAFETY BARRIER
4	QUAD-BEAM TO SINGLE SLOPE BARRIER
5	QUAD-BEAM TO CONCRETE END SHOE
6	QUAD-BEAM TO CONCRETE BRIDGE RAIL

NOTE: TRANSITION ASSEMBLIES FOR THE QUADGUARD M WIDE TO THRIE-BEAM OR W-BEAM FENCE REQUIRES I-BEAM POSTS: ALL POSTS W6X8.5/9 I-BEAMS (78" LONG).

NOTES: CONTACT THE MANUFACTURER WITH SITE SPECIFIC DATA (SSD) FOR THE CORRECT BACKUP ASSEMBLY AND TRANSITION PANELS OR SIDE PANELS USED FOR STANDARD AND BI-DIRECTIONAL INSTALLATIONS: AT DIVIDED-HIGHWAY MEDIANS OR UNDIVIDED ROADWAYS WHERE THE SYSTEM IS EXPOSED TO IMPACTS FROM ONE OR TWO DIFFERENT DIRECTIONS OF TRAFFIC FLOW.

NOTES: CONTACT THE MANUFACTURER WITH SITE SPECIFIC DATA (SSD) FOR CONCRETE PAD AND ANCHOR BLOCK INSTALLATION REQUIREMENTS.

A MANUFACTURER'S DRAWING PACKAGE UNIQUE AND SPECIFIC FOR THE QUADGUARD M WIDE FIELD INSTALLATION AND INFORMATION REGARDING THE TYPE OF BACKUP ASSEMBLY REQUIRED FOR THE TRANSITION WILL BE PROVIDED BY THE MANUFACTURER TO THE ENGINEER AND INSTALLER.

6" REINFORCED CONCRETE PAD REQUIRES THE INSTALLATION OF AN ANCHOR BLOCK AS SHOWN ON THE MANUFACTURER'S DRAWING PACKAGE.

8" NON-REINFORCED CONCRETE PAD MAY NOT REQUIRE AN ANCHOR BLOCK, IF THE PAD IS INSTALLED AGAINST AN IMMOVABLE CONCRETE BACKUP.

CONCRETE PAD AND ANCHOR BLOCK COMBINATIONS SHALL BE CONFIRMED WITH THE MANUFACTURER BASED UPON SITE SPECIFIC DATA (SSD).

NOTE: THE QUADGUARD M WIDE 6-BAY SYSTEM TESTED TO MASH TL-3.

TL-3 MODEL #	QM10069 (627515)	CARTRIDGE TYPES IN BAYS	
BAYS	6	TYPE I	TYPE II
DIAPHRAGMS	6	4	3
WIDTH	69"	REAR	FRONT

**GENERAL NOTES**

- FOR SPECIFIC INFORMATION REGARDING INSTALLATION AND TECHNICAL GUIDANCE OF THE SYSTEM, CONTACT: TRINITY HIGHWAY - ENERGY ABSORPTION INC. AT 1(888)323-6374 OR WEBSITE [www.trinityhighway.com](http://www.trinityhighway.com).
- SEE THE RECENT QUADGUARD M WIDE PRODUCT DESCRIPTION ASSEMBLY MANUAL FOR IMPACT PERFORMANCE CHARACTERISTICS AND DESIGN LIMITATIONS AND THE DRAWING PACKAGE FOR THE SIX (6) BAY WIDE [69"] SYSTEM BEFORE INSTALLING THE QUADGUARD M WIDE AT ANY GIVEN LOCATION.
- COMPONENTS FOR THE QUADGUARD M WIDE BACKUP AND REINFORCING DETAILS ARE SHOWN ON THE QUADGUARD M WIDE PRODUCT DESCRIPTION & ASSEMBLY MANUAL.
- THE INSTALLATION AREA SHOULD BE FREE OF CURBS, ELEVATED OBJECTS, OR DEPRESSIONS.
- FOR PERMANENT APPLICATIONS, QUADGUARD M WIDE SHOULD BE ASSEMBLED ON AN EXISTING OR FRESHLY PLACED AND CURED CONCRETE BASE 28MPa [4,000 PSI] MINIMUM. QUADGUARD M WIDE SYSTEM MAY ALSO BE ASSEMBLED ON REINFORCED OR NON-REINFORCED CONCRETE ROADWAY (MINIMUM 8" THICK).
- CONCRETE PAD SHALL BE 6" MIN. REINFORCED 28MPa [4,000 PSI] (P.C.) OR 8" MIN. NON-REINFORCED 28MPa [4,000 PSI] CONCRETE ROADWAY MEASURING AT LEAST 12'-0" WIDE BY 50'-0" LONG. ANCHOR BLOCK IS NOT REQUIRED WHEN USING 8" CONCRETE PAD INSTALLED AGAINST AN IMMOVABLE STRUCTURE, E.G. CONCRETE WALL.
- IF THE CROSS-SLOPE VARIES MORE THAN 2% OVER THE LENGTH OF THE SYSTEM, THE CONCRETE PAD WILL REQUIRE LEVELING. MAXIMUM PERMISSIBLE CROSS-SLOPE IS 8%.
- FOR BI-DIRECTIONAL TRAFFIC: THE LOCATION AND OR WIDTH OF THE QUADGUARD M WIDE IS RESTRICTED. AS BI-DIRECTIONAL TRAFFIC APPROACHES THE REAR OF THE QUADGUARD M WIDE, THE QUADGUARD M WIDE SHOULD NOT EXTEND FURTHER INTO THE TRAFFIC-SIDE OF THE BARRIER THAN THE OBSTACLE. ANY TRANSITION INSTALLED MUST EITHER BE TANGENT TO BOTH QUADGUARD M WIDE AND OBSTACLE OR MUST ANGLE TOWARD FIELD SIDE OF THE BARRIER.
- SYSTEM TRANSITION: APPROPRIATE TRANSITION PANELS OR SIDE PANELS WILL BE REQUIRED FOR PROPER IMPACT PERFORMANCE. THE CORRECT PANEL(S) TO USE WILL DEPEND ON THE DIRECTION OF TRAFFIC FLOW AND WHAT TYPE OF BARRIER OR ROAD FEATURE THE QUADGUARD M WIDE SYSTEM IS SHIELDING. SEE THE QUADGUARD M WIDE PRODUCT DESCRIPTION & ASSEMBLY MANUAL FOR FURTHER DETAILS.
- THE QUADGUARD M WIDE SYSTEM SHOULD BE INSTALLED APPROXIMATELY PARALLEL WITH THE BARRIER.
- FOR THE TENSION STRUT BACKUP, THE DISTANCE BETWEEN THE BACK OF BACKUP AND THE BARRIER WALL SHOULD NOT EXCEED 7" IN ANY CASE.
- THE WIDE QUADGUARD M WIDE SYSTEM IS ONLY AVAILABLE IN A 69" WIDTH AND HAS A 6-BAY SYSTEM THAT HAS BEEN TESTED TO MASH TEST LEVEL 3.
- IF THE OUTSIDE WIDTH OF OBSTACLE(S) BEING SHIELDED IS 53" OR GREATER, THE OUTSIDE OF OBSTACLE(S) MUST BE CHAMFERED. SEE THE QUADGUARD M WIDE PRODUCT DESCRIPTION & ASSEMBLY MANUAL FOR FURTHER DETAILS.
- SEE THE "QUADGUARD M WIDE SYSTEM PRODUCT MANUAL" FOR A DESCRIPTION OF ITS IMPACT PERFORMANCE CHARACTERISTICS AND DESIGN LIMITATIONS BEFORE PLACING A SYSTEM AT A GIVEN SITE. INFORMATION AND COPIES OF ABOVE MANUAL ARE AVAILABLE BY CALLING CUSTOMER SERVICE DEPARTMENT AT (888) 323-6374.

**FOUNDATION & ANCHORING REQUIREMENTS  
FOUNDATION TYPES: A & B**

FOUNDATION TYPE: A	REINFORCED CONCRETE PAD OR ROADWAY
FOUNDATION:	6" MINIMUM DEPTH WITH ANCHOR BLOCK (P.C.C.)
ANCHORAGE:	7" STUDS EMBEDDED 5 1/2" - APPROVED ADHESIVE
FOUNDATION TYPE: B	REINFORCED OR NON-REINFORCED CONCRETE PAD OR ROADWAY
FOUNDATION:	8" MINIMUM DEPTH (P.C.C.)
ANCHORAGE:	7" STUDS EMBEDDED 5 1/2" - APPROVED ADHESIVE

KEY:  
COMPACTED SUBBASE (C.S.)  
PORTLAND CEMENT CONCRETE (P.C.C.)

NOTE: SEE TRINITY'S PRODUCT DESCRIPTION ASSEMBLY MANUAL FOR THE APPROVED ADHESIVE.

TENSION STRUT BACKUP MAY NOT BE USED IN ASPHALT CONCRETE (A.C.). SEE TRINITY'S PRODUCT DESCRIPTION ASSEMBLY MANUAL FOR MORE INFORMATION.



**TRINITY HIGHWAY  
ENERGY ABSORPTION  
QUADGUARD M WIDE  
(MASH TL-3)  
QG (M) (W) -21**

FILE:	qgmw21.dgn	DN:	TxDOT	CK:	KM	DW:	SS	CK:	CL
© TxDOT:	JULY 2021	CONT:	6435	SECT:	38	JOB:	001	HIGHWAY:	IH10, etc
REVISIONS:		DIST:		COUNTY:		SHEET NO.:			
		BMT:	JEFFERSON, etc						65

**REUSABLE**

NOTE: THIS STANDARD IS A BASIC REPRESENTATION OF THE QUADGUARD QG M WIDE SYSTEM AND IS NOT INTENDED TO REPLACE THE PRODUCT DESCRIPTION ASSEMBLY MANUAL.

DATE:  
FILE:

DISCLAIMER: THIS STANDARD IS GOVERNED BY THE "TEXAS ENGINEERING PRACTICE ACT". NO WARRANTY OF ANY KIND IS MADE BY TxDOT FOR ANY PURPOSE WHATSOEVER. TxDOT ASSUMES NO RESPONSIBILITY FOR THE CONVERSION OF THIS STANDARD TO OTHER FORMATS OR FOR INCORRECT RESULTS OR DAMAGES RESULTING FROM ITS USE.

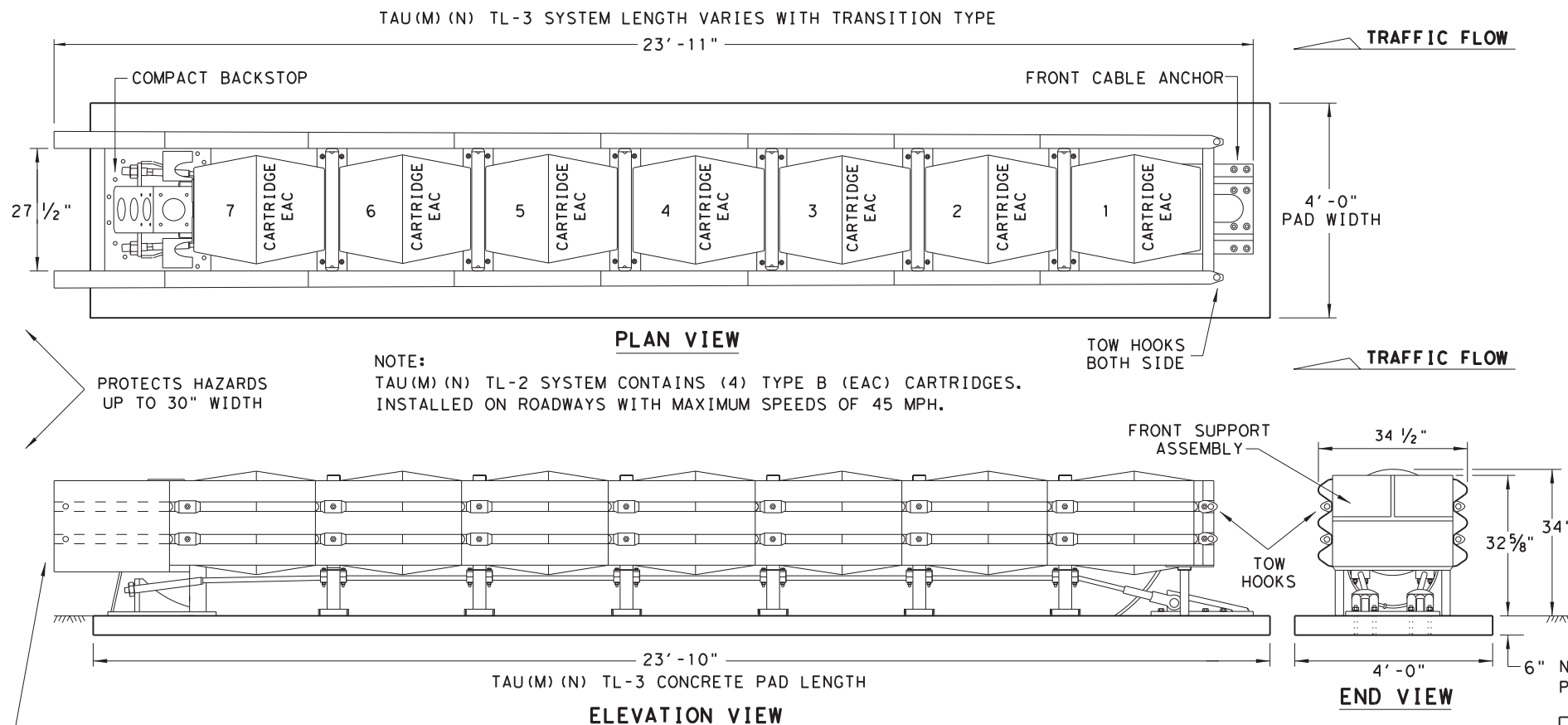

**GENERAL NOTES**

- FOR SPECIFIC INFORMATION REGARDING THE INSTALLATION AND TECHNICAL GUIDANCE OF THE SYSTEM, CONTACT: LINDSAY TRANSPORTATION SOLUTIONS (LTS) - BARRIER SYSTEMS, INC. AT (707) 374-6800. 180 RIVER ROAD, RIO VISTA, CA 94571
- REFER TO THE LATEST (LTS) INSTALLATION INSTRUCTION MANUAL FOR IMPORATANT SAFETY MESSAGES, COMPLETE SYSTEM ASSEMBLY, AND ANCHOR INSTALLATION REQUIREMENTS FOR THE NINE (9) DIFFERENT SITE TRANSITIONS.
- INSTALLATION DETAILS FOR THE COMPACT BACKSTOP, FRONT CABLE ANCHOR AND FOUNDATION OPTIONS ARE SHOWN ON THE INSTALLATION INSTRUCTION MANUAL FURNISHED TO THE ENGINEER.
- CONCRETE SHALL BE CLASS "S" WITH A MINIMUM COMPRESSIVE STRENGTH OF 4,000 P.S.I.
- IF THE CROSS-SLOPES VARIES MORE THAN 2% OVER THE LENGTH OF THE SYSTEM, THE CONCRETE PAD WILL REQUIRE LEVELING. MAXIMUM PERMISSIBLE CROSS-SLOPE IS 8%
- THE INSTALLATION AREA SHOULD BE FREE FROM CURBS, ELEVATED OBJECTS, OR DEPRESSIONS.
- THE TAU(M) (N) SYSTEM SHOULD BE APPROXIMATELY PARALLEL WITH THE BARRIER OR CENTER LINE OF MERGING BARRIERS.
- THIS DRAWING REPRESENTS THE UNIVERSAL TAU(M) (N) TL-3 SYSTEM, A RE-DIRECTIVE NON-GATING CRASH CUSHION THAT CAN PROTECT HAZARDS UP TO 30-INCHES IN WIDTH. ALSO AVAILABLE IN TL-2 CONFIGURATION.

NOTE:  
 TAU(M) (N) TL-2 SYSTEM CONTAINS (4) TYPE B (EAC) CARTRIDGES.  
 INSTALLED ON ROADWAYS WITH MAXIMUM SPEEDS OF 45 MPH.

NOTE:  
 PAD THICKNESS VARIES - SEE FOUNDATION OPTIONS

NOTES:  
 TRANSITIONS AND ATTACHMENTS TO VARIOUS BARRIER SHAPES, RAILINGS AND BI-DIRECTIONAL TRAFFIC FLOWS ARE AVAILABLE. SEE MANUFACTURER'S INSTALLATION INSTRUCTIONS MANUAL FOR ADDITIONAL TRANSITION DETAILS.

NOTE:  
 CONCRETE FOUNDATION PAD LENGTH VARIES WITH TL-3 AND TL-2 SYSTEMS, SEE SYSTEM & FOUNDATION LENGTH TABLE.

BILL OF MATERIALS FOR TAU(M) (N) TL-3 & TL-2 SYSTEMS		QUANTITIES	
PART NUMBER	PART DESCRIPTION	TL-3 SYSTEM	TL-2 SYSTEM
BSI-1708019-00	SLIDING PANEL GALVANIZED TAU(M) (N)	14	8
BSI-1708030-00	END PANEL, THRIE BEAM, GALV, TAU(M) (N)	2	2
BSI-1706001-00	CABLE ASSEMBLY, 7 BAY, TAU(M) (N)	2	-
BSI-1805036-00	CABLE ASSEMBLY, 4 BAY, TAU(M) (N)	-	2
BSI-1708018-00	FRONT CABLE ANCHOR	1	1
BSI-1707034-00	COMPACT BACKSTOP	1	1
B030703	MIDDLE SUPPORT ASSEMBLY	6	3
B030704	FRONT SUPPORT	1	1
B010722	ENERGY ABSORBING CARTRIDGE, TYPE B	7	4
K001005	TAU-II FRONT SUPPORT LEG KIT	1	1
BSI-1709083-KT	TETHER KIT (INCLUDES ALL HARDWARE)	1	1
BSI-1809041-KT	SLIDER KIT (INCLUDES ALL HARDWARE)	7	4
BSI-1808033-KT	CABLE GUIDE KIT (INCLUDES ALL HARDWARE)	6	3
BSI-1809040-KT	TOW HOOK KIT (INCLUDES ALL HARDWARE)	1	1
BSI-1808034-KT	DELINEATION BRACKET KIT (INCLUDES ALL HARDWARE)	1	1
BSI-1808035-KT	END PANEL MOUNT KIT (INCLUDES ALL HARDWARE)	1	1
BSI-1808036-KT	CONCRETE ANCHORING KIT	1	1
SEE NOTE	HIGH REFLECTIVE DECAL	1	1
ECN 3883	INSTALLATION AND INSTRUCTIONS MANUAL	1	1

FOUNDATION OPTIONS
6" REINFORCED CONCRETE
8" UNREINFORCED CONCRETE
ASPHALT OVER CONCRETE WITH MINIMUM 6" EMBEDMENT IN CONCRETE
* 6" ASPHALT OVER 6" COMPACT SUBBASE
* 8" MINIMUM ASPHALT

SYSTEM & FOUNDATION LENGTH TABLE	
SYSTEM LENGTH	FOUNDATION LENGTH
TL-2 = 15'-5"	TL-2 = 15'-4"
TL-3 = 23'-11"	TL-3 = 23'-10"

\* NOTE:  
 REQUIRES AN ASPHALT ANCHORAGE PACKAGE: INCLUDES ADDITIONAL BRACES FOR THE FRONT CABLE ANCHOR AND THE COMPACT BACKSTOP, AND ASPHALT HARDWARE KIT. THE TL-3 ASPHALT CONFIGURATION ALSO REQUIRES NESTED SLIDER PANELS AND SHIMS AT THE LAST TWO BAYS. SEE MANUFACTURER'S INSTALLATION INSTRUCTION MANUAL FOR DETAILS.

\* \* NOTE:  
 ENGINEER OR CONTRACTOR SHALL COORDINATE WITH THE MANUFACTURER FOR THE CORRECT DECAL PER TRAFFIC FLOW, LEFT, RIGHT OR BOTH-SIDES.

NOTE:  
 SEE MANUFACTURER'S INSTALLATION INSTRUCTION MANUAL FOR FOUNDATION SPECIFICATIONS THAT INCLUDE, STONE AGGREGATE MIX, COMPRESSION STRENGTH, STEEL SIZE, ANCHOR SIZE, AND EMBEDMENT DEPTH.

NOTE:  
 DELINEATION BRACKET ATTACHES TO FRONT SUPPORT ASSEMBLY.

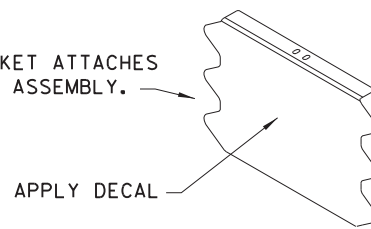

**DELINEATION BRACKET**

NOTE:  
 APPLY A HIGH REFLECTIVE DECAL TO THE DELINEATION BRACKET. DELINEATION DECAL ORIENTATION IS SHOWN ON THE CONSTRUCTION PLAN SET AND SHALL BE IN ACCORDANCE WITH THE TEXAS MUTCD FOR (TRAFFIC CONTROL DEVICES). DECALS ARE AVAILABLE FOR TRAFFIC FLOW ON THE LEFT-SIDE, BOTH -SIDES AND RIGHT-SIDE.

NOTES:  
 UPGRADE KITS ARE AVAILABLE TO RETROFIT EXISTING NCHRP 350 TAU-II SYSTEMS TO MASH COMPLIANT SYSTEMS. SEE MANUFACTURER'S PRODUCT INFORMATION.

THE TAU(M) (N) UNIDIRECTIONAL SYSTEM IS FREE STANDING AND IS NOT REQUIRED TO BE CONNECTED TO THE HAZARD.

TRANSITIONS TO GUARD FENCE, BRIDGE RAILS AND ROADSIDE BARRIERS SHALL BE IN ACCORDANCE WITH TxDOT'S POLICY.

NOTE:  
 THIS STANDARD IS A BASIC REPRESENTATION OF THE UNIVERSAL TAU(M) (N) SYSTEM, IT IS NOT INTENDED TO REPLACE THE INSTALLATION INSTRUCTION MANUAL.

**REUSABLE**

Design Division Standard

LINDSAY TRANSPORTATION SOLUTIONS  
 UNIVERSAL  
 CRASH CUSHION  
 (MASH TL-3 & TL-2)  
 TAU(M) (N) - 19

FILE: tau19.dgn	DW: TxDOT	CK: KM	DW: VP	CK:
© TxDOT: APRIL 2019	CONT	SECT	JOB	HIGHWAY
REVISIONS	<b>6435</b>	<b>38</b>	<b>001</b>	<b>IH10, etc</b>
DIST	COUNTY		SHEET NO.	
BMT	JEFFERSON, etc		<b>66</b>	

DATE:  
 FILE:

DISCLAIMER: THIS STANDARD IS GOVERNED BY THE "TEXAS ENGINEERING PRACTICE ACT". NO WARRANTY OF ANY KIND IS MADE BY TXDOT FOR ANY PURPOSE WHATSOEVER. TXDOT ASSUMES NO RESPONSIBILITY FOR THE CONVERSION OF THIS STANDARD TO OTHER FORMATS OR FOR INCORRECT RESULTS OR DAMAGES RESULTING FROM ITS USE.

NOTE:  
A TRANSITION MAY BE REQUIRED TO INSTALL THE QUADGUARD M10 TO THE OBJECT BEING SHIELDED.

**QUADGUARD M10 24" WIDE 6-BAY SYSTEM**

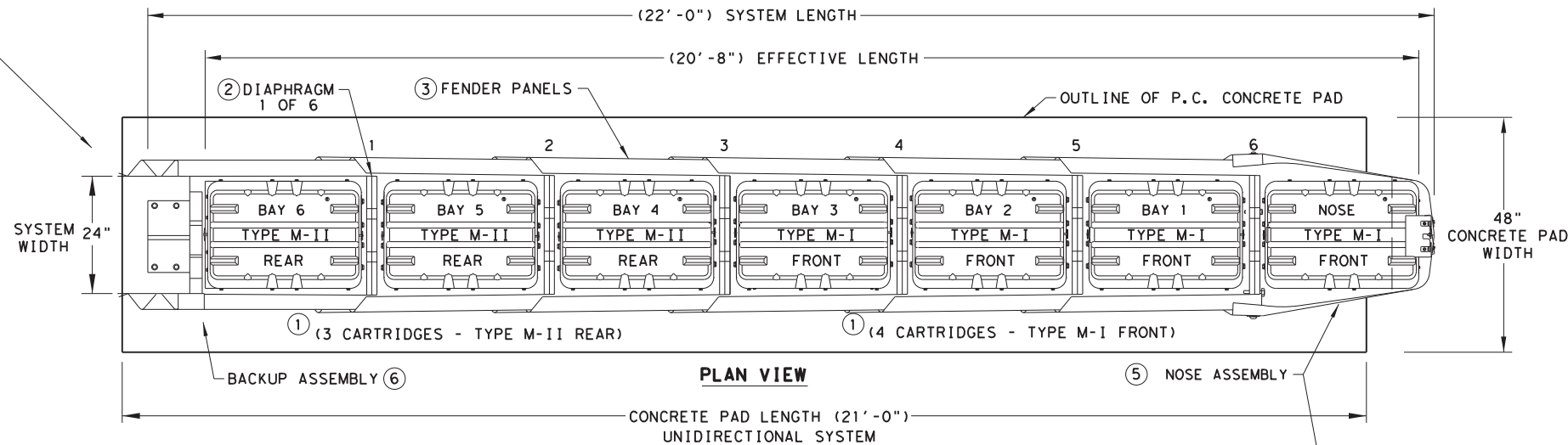

KEY		KEY	
①	QUADGUARD CARTRIDGE	④	MONORAILS
②	DIAPHRAGM	⑤	NOSE ASSEMBLY
③	FENDER PANEL	⑥	BACKUP ASSEMBLY

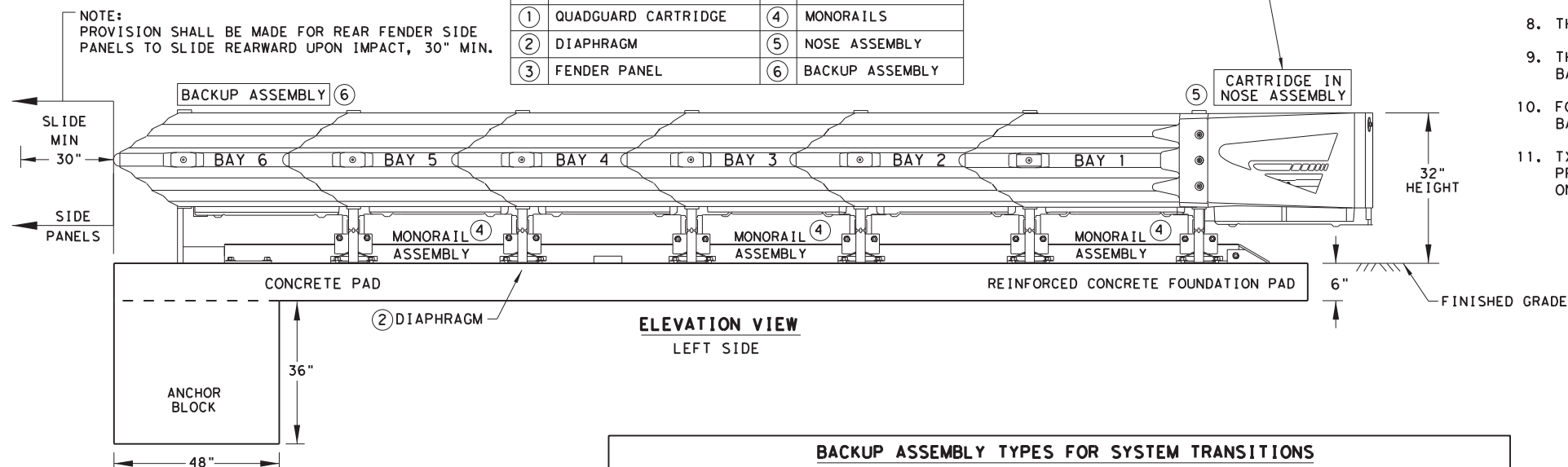

**BACKUP ASSEMBLY TYPES FOR SYSTEM TRANSITIONS**

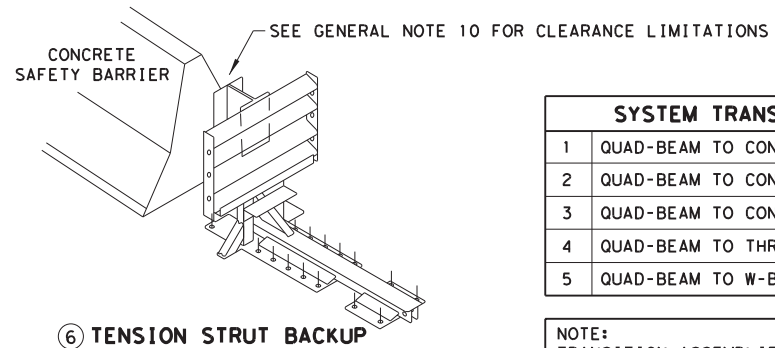

SYSTEM TRANSITIONS TYPES	
1	QUAD-BEAM TO CONCRETE SAFETY BARRIER
2	QUAD-BEAM TO CONCRETE BRIDGE RAIL
3	QUAD-BEAM TO CONCRETE END SHOE
4	QUAD-BEAM TO THRIE-BEAM RAIL
5	QUAD-BEAM TO W-BEAM RAIL

NOTE:  
TRANSITION ASSEMBLIES FOR THE QUADGUARD M10 TO THRIE-BEAM OR W-BEAM FENCE REQUIRES I-BEAM POSTS:  
ALL POSTS W6x8.5/9 I-BEAMS (78" LONG).

NOTES:  
CONTACT THE MANUFACTURER WITH SITE SPECIFIC DATA (SSD) FOR THE CORRECT BACKUP ASSEMBLY AND TRANSITION PANELS OR SIDE PANELS USED FOR STANDARD AND BI-DIRECTIONAL INSTALLATIONS: AT DIVIDED-HIGHWAY MEDIANS OR UNDIVIDED ROADWAYS WHERE THE SYSTEM IS EXPOSED TO IMPACTS FROM ONE OR TWO DIFFERENT DIRECTIONS OF TRAFFIC FLOW.

**GENERAL NOTES**

- FOR SPECIFIC INFORMATION REGARDING INSTALLATION AND TECHNICAL GUIDANCE OF THE SYSTEM, CONTACT: TRINITY HIGHWAY - ENERGY ABSORPTION INC. AT 1 (888) 323-6374.
- SEE THE RECENT QUADGUARD M10 PRODUCT DESCRIPTION ASSEMBLY MANUAL FOR IMPACT PERFORMANCE CHARACTERISTICS AND DESIGN LIMITATIONS AND THE DRAWING PACKAGE FOR THE NARROW 24" SYSTEM BEFORE INSTALLING THE QUADGUARD M10 SYSTEM AT ANY GIVEN LOCATION.
- FOR BI-DIRECTIONAL TRAFFIC: THE PLACEMENT OF THE QUADGUARD M10 IS RESTRICTED. AS BI-DIRECTIONAL TRAFFIC APPROACHES THE REAR OF THE QUADGUARD M10 THE CRASH CUSHION MUST BE PLACED SUCH THAT THE TRAFFIC SIDE OF CRASH CUSHION IS AT LEAST AS FAR FROM ADJACENT TRAVEL LANE LINE AS THE TRAFFIC SIDE OF BARRIER/OBJECT BEING SHIELDED.
- SYSTEM TRANSITION: APPROPRIATE TRANSITION PANELS OR SIDE PANELS WILL BE REQUIRED FOR PROPER IMPACT PERFORMANCE. THE CORRECT PANEL(S) TO USE WILL DEPEND ON THE DIRECTION OF TRAFFIC FLOW AND WHAT TYPE OF BARRIER OR ROAD FEATURE THE QUADGUARD M10 SYSTEM IS SHIELDING. SEE THE QUADGUARD M10 PRODUCT DESCRIPTION & ASSEMBLY MANUAL FOR FURTHER DETAILS.
- COMPONENTS FOR THE QUADGUARD M10 BACKUP AND REINFORCING DETAILS ARE SHOWN ON THE QUADGUARD M10 PRODUCT DESCRIPTION & ASSEMBLY MANUAL.
- CONCRETE PAD SHALL BE 6" MIN. REINFORCED 28MPa [4,000 PSI] (P.C.) OR 8" MIN. NON-REINFORCED 28MPa [4,000 PSI] CONCRETE ROADWAY MEASURING AT LEAST 12'-0" WIDE BY 50'-0" LONG. ANCHOR BLOCK IS NOT REQUIRED WHEN USING 8" CONCRETE PAD INSTALLED AGAINST AN IMMOVABLE STRUCTURE, E.G. CONCRETE WALL.
- IF THE CROSS-SLOPE VARIES MORE THAN 2% OVER THE LENGTH OF THE SYSTEM, THE CONCRETE PAD WILL REQUIRE LEVELING. MAXIMUM PERMISSIBLE CROSS-SLOPE IS 8%.
- THE INSTALLATION AREA SHOULD BE FREE OF CURBS, ELEVATED OBJECTS, OR DEPRESSIONS.
- THE QUADGUARD M10 SYSTEM SHOULD BE INSTALLED APPROXIMATELY PARALLEL WITH THE BARRIER.
- FOR THE TENSION STRUT BACKUP THE DISTANCE BETWEEN THE BACK OF BACKUP AND THE BARRIER WALL SHOULD NOT EXCEED 7" IN ANY CASE.
- TXDOT HAS ONLY APPROVED THE 24" WIDE QUADGUARD M10 SYSTEM. THE QUADGUARD M10 PRODUCT DESCRIPTION AND ASSEMBLY MANUAL INCLUDES SYSTEM WIDTH OF 24". ONLY THE 24" SYSTEM IS ALLOWED TO BE INSTALLED ON TEXAS ROADWAYS.

**FOUNDATION & ANCHORING REQUIREMENTS**  
FOUNDATION TYPES: A, B, C, & D

FOUNDATION TYPE: A	REINFORCED CONCRETE PAD OR ROADWAY
FOUNDATION:	6" MINIMUM DEPTH (P.C.C.)
ANCHORAGE:	7" STUDS EMBEDDED 5 1/2" - APPROVED ADHESIVE
FOUNDATION TYPE: B	ASPHALT OVER P.C.C.
FOUNDATION:	3" MIN. (A.C.) OVER 3" MIN. (P.C.C.)
ANCHORAGE:	18" THREADED ROD EMBEDDED 16 1/2" - APPROVED ADHESIVE
FOUNDATION TYPE: C	ASPHALT OVER SUBBASE
FOUNDATION:	6" MIN. (A.C.) OVER 6" MIN. (C.S.)
ANCHORAGE:	18" THREADED ROD EMBEDDED 16 1/2" - APPROVED ADHESIVE
FOUNDATION TYPE: D	ASPHALT ONLY
FOUNDATION:	8" MIN. (A.C.)
ANCHORAGE:	18" THREADED ROD EMBEDDED 16 1/2" - APPROVED ADHESIVE

KEY:  
ASPHALT CONCRETE (A.C.)  
COMPACTED SUBBASE (C.S.)  
PORTLAND CEMENT CONCRETE (P.C.C.)

NOTE: SEE TRINITY'S PRODUCT DESCRIPTION ASSEMBLY MANUAL FOR THE APPROVED ADHESIVE.

IF THE UNIT IS ANCHORED TO ASPHALTIC CONCRETE, IT SHOULD BE RELOCATED TO FRESH, UNDISTURBED ASPHALT AND RE-ANCHORED AFTER EACH IMPACT TO ENSURE ADEQUATE FUTURE PERFORMANCE.

TENSION STRUT BACKUP MAY BE USED IN CONSTRUCTION ZONES ON ASPHALT CONCRETE (A.C.) FOR TEMPORARY USE ONLY.

NOTES:  
CONTACT THE MANUFACTURER WITH SITE SPECIFIC DATA (SSD) FOR CONCRETE PAD AND ANCHOR BLOCK INSTALLATION REQUIREMENTS.

A MANUFACTURER'S DRAWING PACKAGE UNIQUE AND SPECIFIC FOR THE QUADGUARD M10 (N) INSTALLATION AND DETAILED INFORMATION REGARDING THE TYPE OF BACKUP ASSEMBLY FOR THE REQUIRED TRANSITION WILL BE PROVIDED TO THE ENGINEER AND INSTALLER.

6" REINFORCED CONCRETE PAD REQUIRES THE INSTALLATION OF AN ANCHOR BLOCK AS SHOWN ON THE MANUFACTURER'S DRAWING PACKAGE.

8" NON-REINFORCED CONCRETE PAD MAY NOT REQUIRE AN ANCHOR BLOCK, IF THE PAD IS INSTALLED AGAINST AN IMMOVABLE CONCRETE BACKUP.

CONCRETE PAD AND ANCHOR BLOCK COMBINATIONS SHALL BE CONFIRMED WITH THE MANUFACTURER BASED UPON SITE SPECIFIC DATA (SSD).

NOTE:  
THE QUADGUARD M10 24" WIDE 6-BAY - NARROW SYSTEM HAS BEEN TESTED TO MASH TEST LEVEL 3.

TL-3 MODEL #	QM10024	CARTRIDGE TYPES IN BAYS		
BAYS	6	TYPE-MII	TYPE-MI	TYPE-MI
DIAPHRAGMS	6	3	3	1
WIDTH	24"	REAR	FRONT	NOSE

TL-2 MODEL #	QM7024	CARTRIDGE TYPES IN BAYS		
BAYS	3	TYPE-MII	TYPE-MI	TYPE-MI
DIAPHRAGMS	3	1	2	1
WIDTH	24"	REAR	FRONT	NOSE

NOTE:  
THIS STANDARD IS A BASIC REPRESENTATION OF THE QUADGUARD M10 SYSTEM AND IS NOT INTENDED TO REPLACE THE PRODUCT DESCRIPTION ASSEMBLY MANUAL.

**REUSABLE**

		Design Division Standard	
<b>TRINITY HIGHWAY ENERGY ABSORPTION QUADGUARD M10 (MASH TL-3 &amp; TL-2 NARROW-24" ONLY)</b>			
<b>QUADGUARD (M10) (N) - 20</b>			
FILE: qguardm10n20.dgn	DN: TXDOT	CK: KM	DW: VP
© TXDOT: NOVEMBER 2020	CONT SECT	JOB	HIGHWAY
REVISIONS	6435 38	001	IHT0, etc
DIST	COUNTY	SHEET NO.	
BMT	JEFFERSON, etc	67	

DATE:  
FILE:

DISCLAIMER: The use of this standard is governed by the "Texas Engineering Practice Act". No warranty of any kind is made by TxDOT for any purpose whatsoever. TxDOT assumes no responsibility for the conversion of this standard to other formats or for incorrect results or damages resulting from its use.

DATE: 2/28/2023  
 FILE: T:\BMT\AO\01 - CSJ Project Files\6435-38-001\MBGF\_2024\Design\DCGN\gfmq.dgn

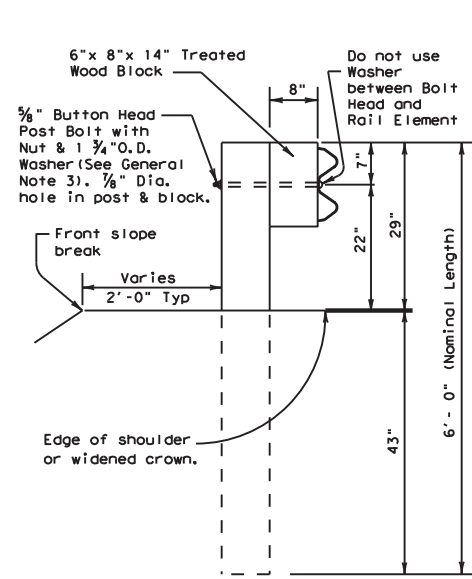

**TYPICAL POST**

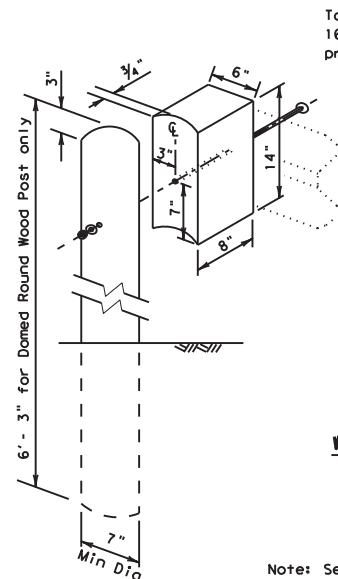

**WOOD BLOCK TO ROUND WOOD POST**

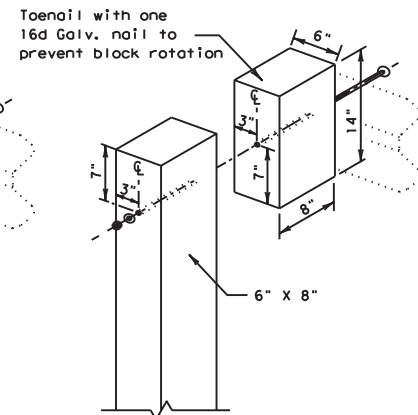

**WOOD BLOCK TO RECTANGULAR WOOD POST**

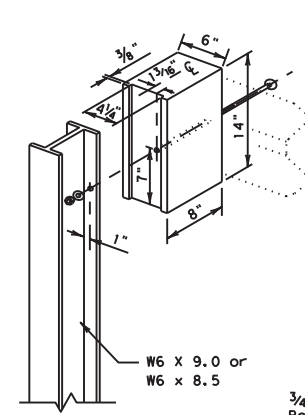

**WOOD BLOCK TO STEEL POST**

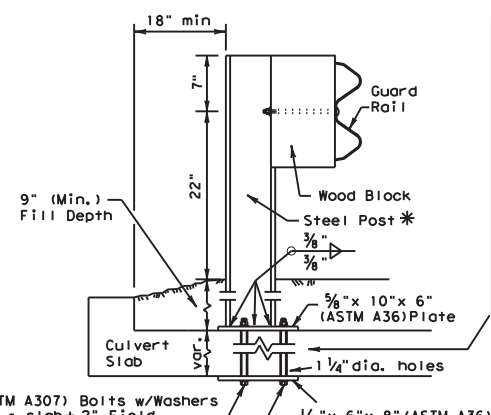

3/4" dia. (ASTM A307) Bolts w/Washers  
 Bolt length = slab + 2" Field  
 clip topside washers if  
 necessary to clear weld.  
 Direction of bolt  
 placement is upward.

**\* LOW FILL CULVERT POST**

**FOR USE ON NON-BRIDGE CLASS CULVERTS ONLY**

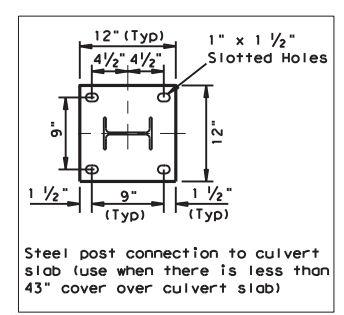

Steel post connection to culvert  
 slab (use when there is less than  
 43" cover over culvert slab)

\* Post(s) may require field  
 modifications to ensure  
 proper guardrail height.

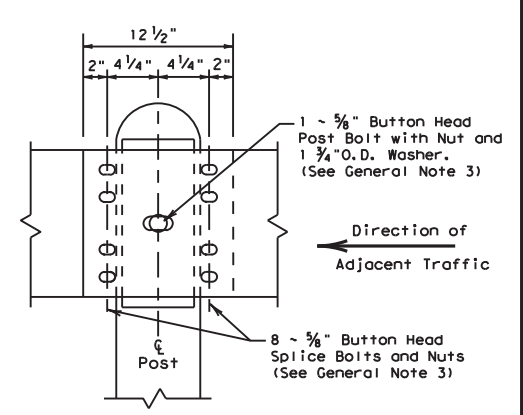

**RAIL SPLICE DETAIL**

**GENERAL NOTES**

- The type of post (round wood post, rectangular wood post, or steel post) will be shown elsewhere in the plans. The exact position of MGBF shall be shown elsewhere in the plans or as directed by the Engineer. Steel posts to be galvanized in accordance with Item 445, "Galvanizing."
- Rail element shall meet the requirements of Item 540, "Metal Beam Guard Fence" except as modified on the plans. The Contractor may furnish rail elements of 12 1/2 or 25 foot nominal lengths.
- Button head "post" bolts (ASTM A307) shall be of sufficient length to extend through the full thickness of the nut (ASTM A563) and Type A (1 3/4" O.D.) washer and not more than 1" beyond it. Button head "splice" bolts (ASTM A307) are 3/8" x 1 1/4" (or 2" long at triple rail splices) with a 3/8" double recessed nut (ASTM A563).
- Fittings (bolts, nuts, and washers) shall be galvanized in accordance with Item 445, "Galvanizing." Fittings shall be subsidiary to the bid item.
- Crown shall be widened to accommodate the Metal Beam Guard Fence.
- The lateral approach to the guard fence, shall have a slope rate of not more than 1V:10H.
- Unless otherwise shown in the plans, guard fence placed in the vicinity of curbs shall be positioned so that the face of curb is located directly below or behind the face of the block. Rail placed over curbs shall be installed so that the post bolt is located approximately 21 inches above the gutter pan or roadway surface.
- If solid rock is encountered within 0 to 18" of the finished grade, drill a 22" dia. hole, 24" into the rock, or drill two 12" dia. front to back overlapping holes, 24" into the rock. If solid rock is encountered below 18", drill a 12" dia. hole, 12" into the rock or to the standard embedment depth, whichever is less. Any excess post length, after meeting these depths, may be field cut to ensure proper guardrail mounting height. Backfill with a cohesionless material.
- Posts shall not be set in concrete, of any depth.
- Special fabrication will be required at installations having a curvature of less than 150 ft. radius.
- The terminal anchor section (TAS) post shall be set in Class A concrete (unless otherwise shown in the plans) in accordance with Item 421, "Hydraulic Cement Concrete." Concrete shall be subsidiary to the bid item requiring construction of the terminal anchor section (TAS). Terminal anchor post to be galvanized in accordance with Item 445, "Galvanizing."
- Unless otherwise shown in the plans, a composite material post and/or block that meets the requirements of DMS-7210, "Composite Material Posts and Blocks for Metal Beam Guard Fence" may be substituted for posts and/or blocks of similar dimensions. The Construction Division, TxDOT maintains a Material Producer List (MPL) for producers of materials conforming to DMS-7210. Only producers on the MPL can furnish composite material posts and/or blocks.

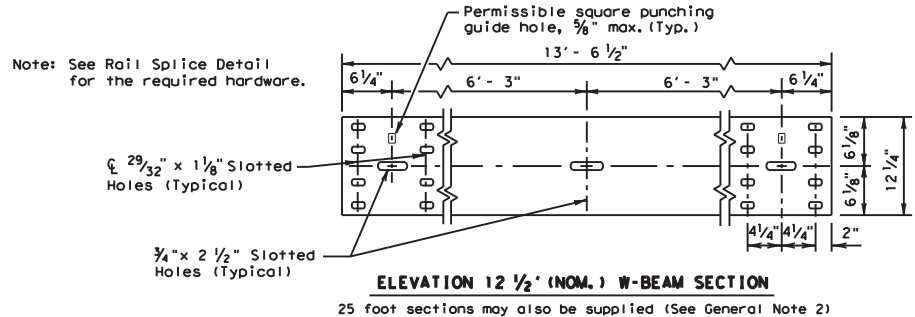

**ELEVATION 12 1/2' (NOM.) W-BEAM SECTION**

25 foot sections may also be supplied (See General Note 2)

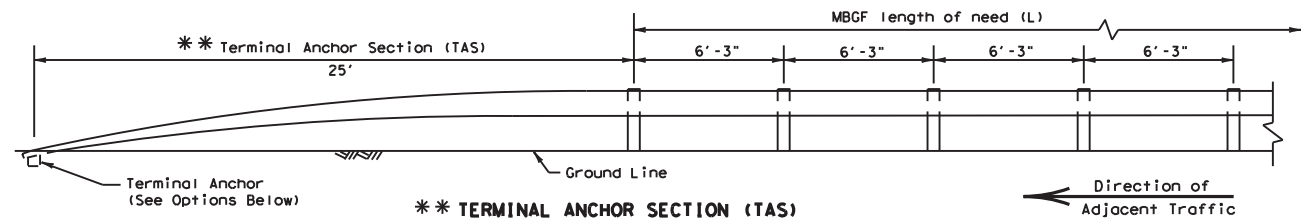

**\*\* TERMINAL ANCHOR SECTION (TAS)**

Terminal anchor sections are only for downstream use, when located outside the horizontal clearance area of opposing traffic.

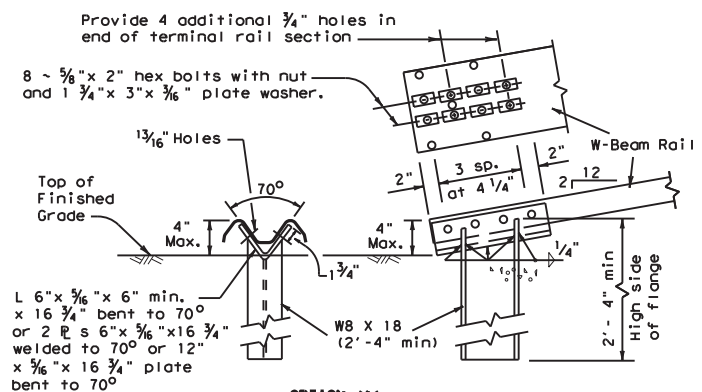

**OPTION (1)**

Note: This anchor post requires four additional 3/4" holes (shop or field) in the rail member with eight 5/8" hex bolts with nut and plate washer.

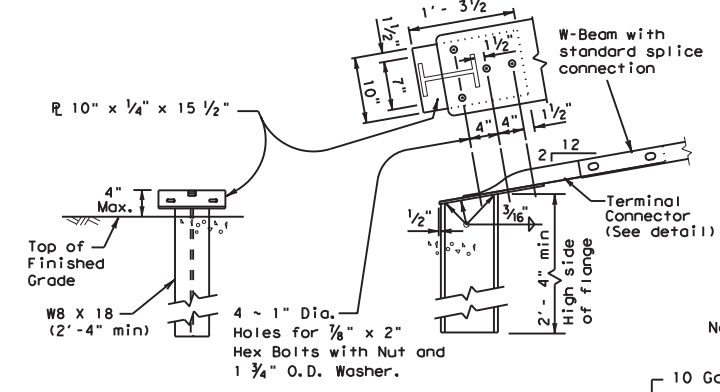

**OPTION (2)**

Note: This anchor post requires the use of the 10 ga. terminal connector with four 5/8" hex bolts with nut and washer.

**TERMINAL ANCHOR POST OPTIONS**

(See General Note 11)

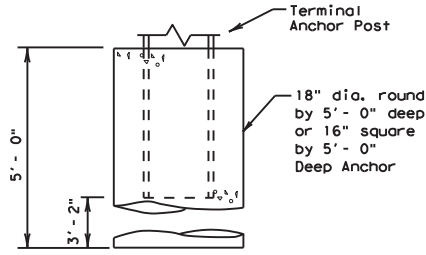

Notes:

Either concrete anchor may be used with either post option above. No construction joint is allowed in the concrete anchor. Terminal rail may be bolted to post and in twist position prior to placing concrete anchor. If concrete anchor is precast, the area should be compacted as directed by the Engineer, when placed in the field.

**TERMINAL CONCRETE ANCHOR OPTIONS**

(See General Note 11)

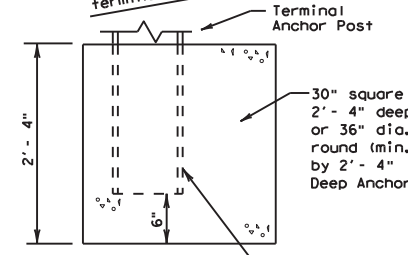

Place face of post approx. on center of anchor

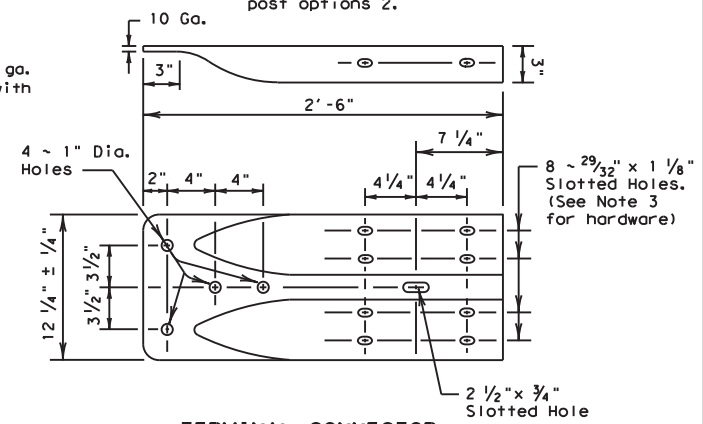

**TERMINAL CONNECTOR**

For connection hardware to concrete rails, see the MGBF transition standards.

**ONLY FOR USE IN MAINTENANCE REPAIRS OR HIGHLY CONSTRAINED SITE CONDITIONS.**



**METAL BEAM GUARD FENCE**

**MBGF-19**

FILE: mbgf19.dgn	DN: TxDOT	CK: KM	DW: BD	CK: VP
© TxDOT NOVEMBER 2019	CONT	SECT	JOB	HIGHWAY
REVISIONS	6435	38	001	IH10, etc
	DIST	COUNTY		SHEET NO.
	BMT	JEFFERSON, etc		68

DISCLAIMER: THE USE OF THIS STANDARD IS COVERED BY THE "TEXAS ENGINEERING PRACTICE ACT". NO WARRANTY OF ANY KIND IS MADE BY TxDOT FOR ANY PURPOSE WHATSOEVER. TxDOT ASSUMES NO RESPONSIBILITY FOR THE CONVERSION OF THIS STANDARD TO OTHER FORMATS OR FOR INCORRECT RESULTS OR DAMAGES RESULTING FROM ITS USE.

DATE: 2/28/2023  
 FILE: T:\BMT\AO\01 - CSJ Project Files\6435-38-001\MBGF 2024\Design\GNG\gfmq.dgn

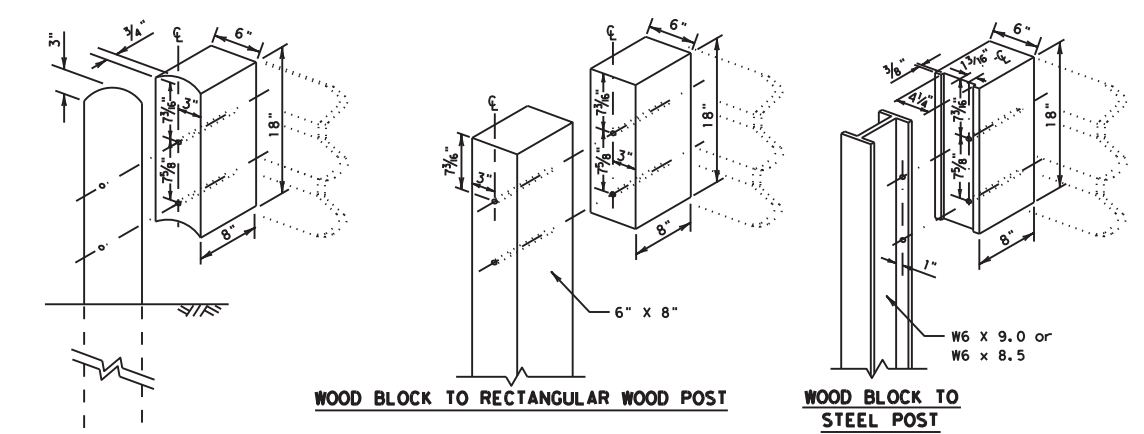
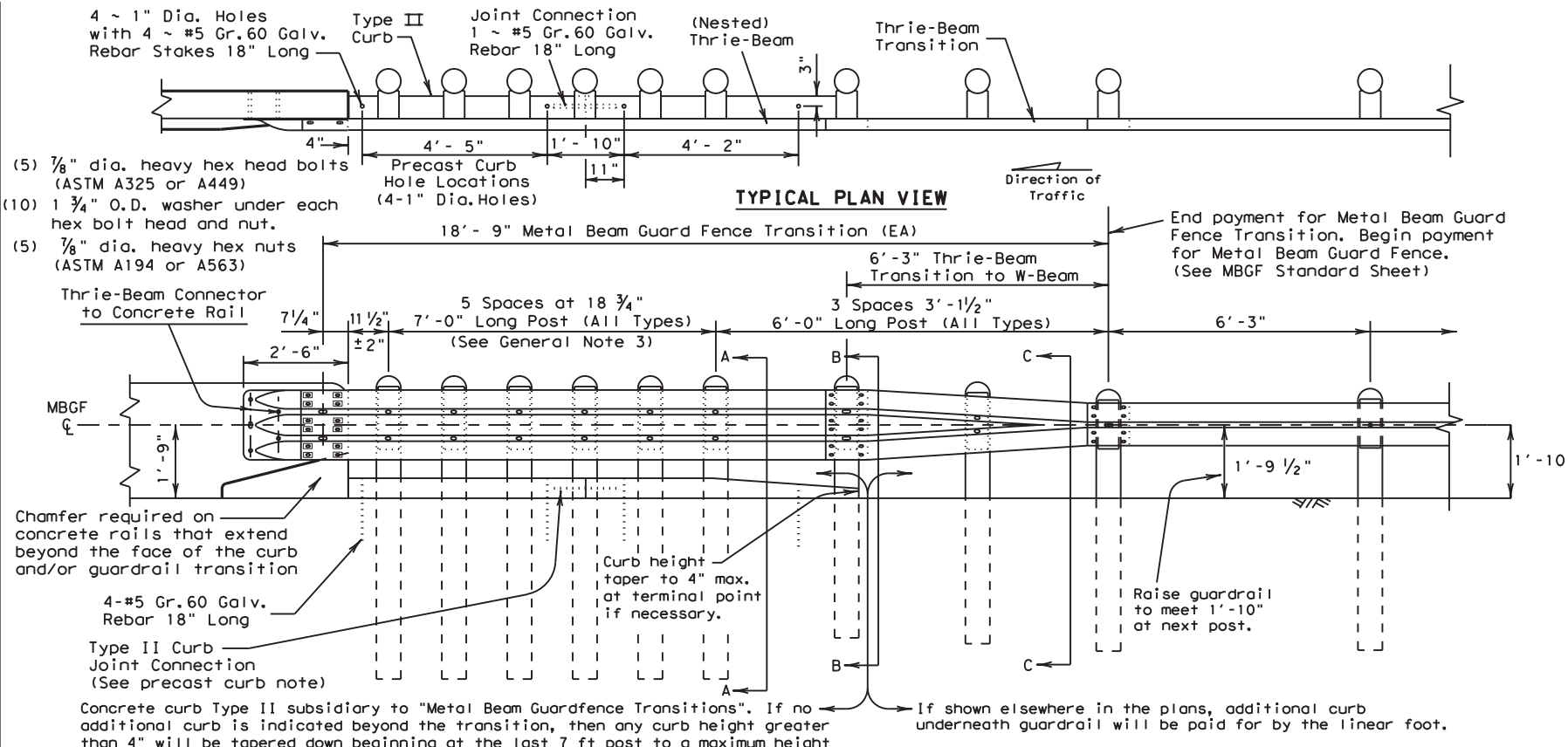

**GENERAL NOTES**

- Concrete curb may be cast-in-place or precast as shown on this sheet. When used in conjunction with thrie-beam guard fence transitions, curb shall be Type II (Typically 5 3/4" height above surface; See CCCC standard sheet) unless otherwise shown in the plans. If other curb heights are shown in the plans in conjunction with the transition, the curb height may be from 4" to 8" with a relatively vertical face. Concrete curb shall be continuous to the seventh post.
- Contact the Design Division for drainage cut options needed within the curb section of the transition.
- The type of post (round wood, rectangular wood or steel) will be shown elsewhere in the plans.
- The post length shall be marked on all 7'-0" long posts by the Manufacturer. The mark shall be located within the top 1 ft. region of the post, at least 3/8" in height, and visible after installation. Wooden posts shall be marked with a brand, and steel posts with a stencil before galvanizing.
- Rail element shall meet the requirements of Item 540, "Metal Beam Guard Fence" except as modified on the plans. The thrie-beam terminal connector and the thrie-beam transition to w-beam shall be of the same material, but shall not be less than 10 gauge.
- Contractor shall verify that the locations of bolt holes match those in the thrie-beam terminal connector prior to ordering materials.
- Unless otherwise shown in the plans, transitions shall be placed with the block face in front of or directly above the curb face.
- Install terminal connector with (12) rectangular guardrail plate washers: (FWR03) and (12) 5/8" x 2" button head splice bolts with recessed nuts.
- Button head "post bolts & nuts" shall meet the requirements of (ASTM A307), and shall be of sufficient length to extend through the full thickness of the nut and 5/8" washer (FWC16a) and not more than 1" beyond it. Trim remaining bolt length to meet required length.
- Fittings (bolts, nuts, and washers) shall be galvanized in accordance with Item 445, "Galvanizing". Fittings shall be subsidiary to the bid item.
- Crown shall be widened to accommodate transitions.
- If solid rock is encountered. See the MBGF standard sheet for the proper installation guidance.
- Posts shall not be set in concrete.
- Unless otherwise shown in the plans, a composite material post and/or block that meets the requirements of DMS-7210, "Composite Material Posts and Blocks for Metal Beam Guard Fence" may be substituted for posts and/or blocks of similar dimensions. The Construction Division, TxDOT, maintains a Material Producer List (MPL) for producers of materials conforming to DMS-7210. Only producers on the MPL can furnish composite material posts and/or blocks.

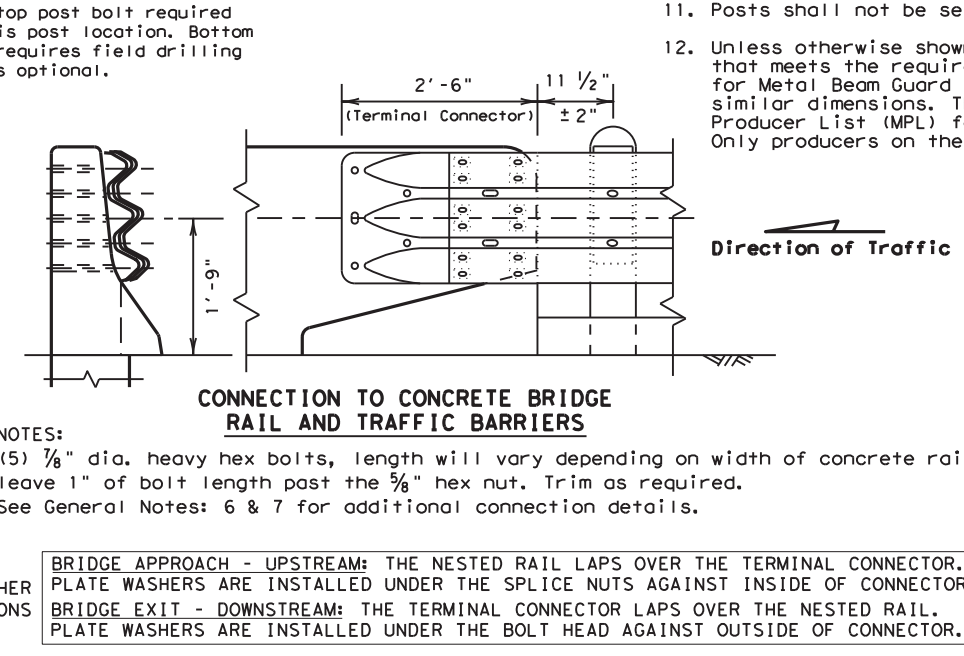
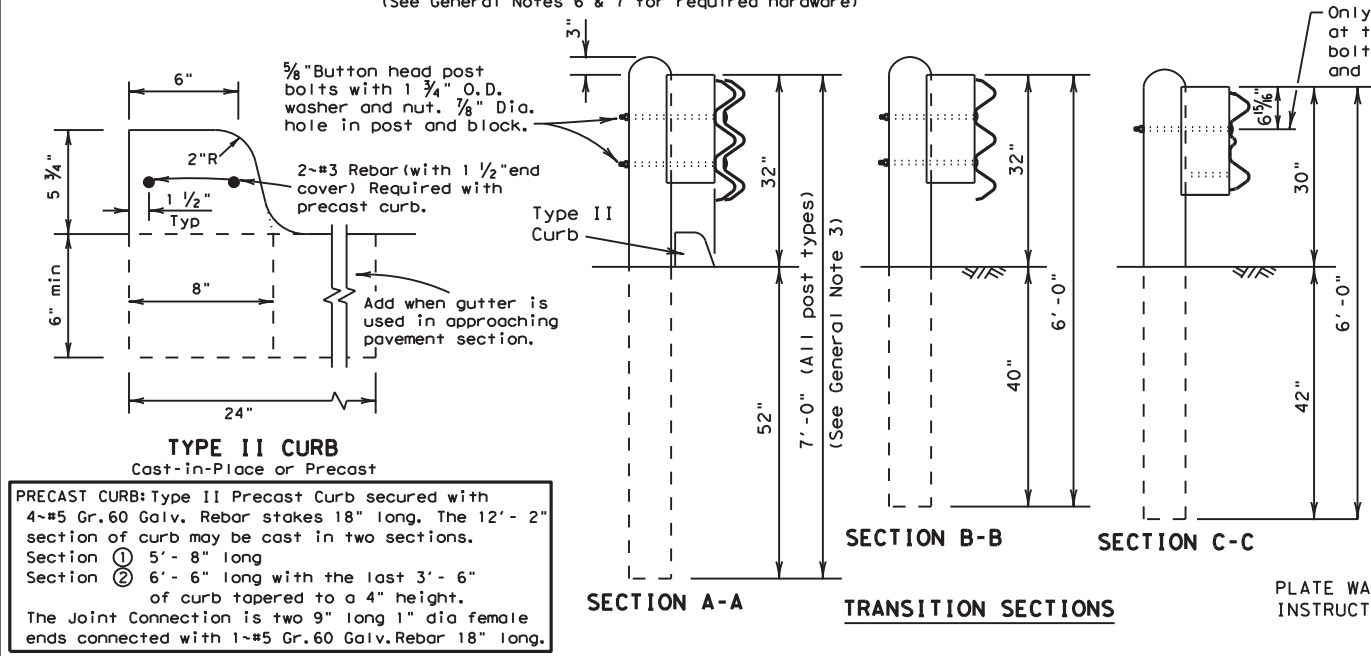
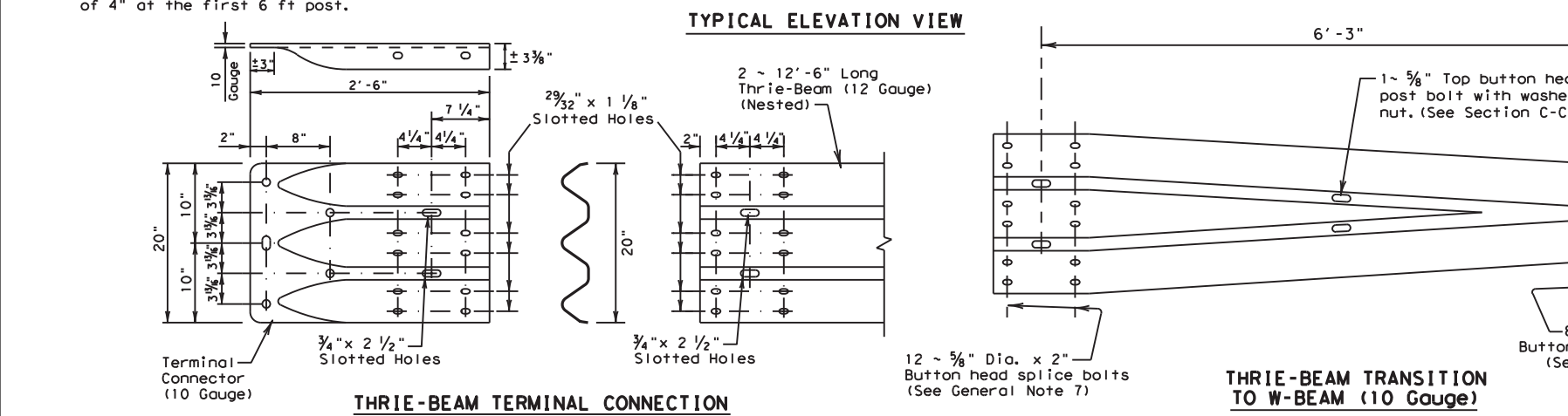

**NOTES:**  
 (5) 7/8" dia. heavy hex bolts, length will vary depending on width of concrete rail, leave 1" of bolt length past the 5/8" hex nut. Trim as required.  
 See General Notes: 6 & 7 for additional connection details.

**BRIDGE APPROACH - UPSTREAM:** THE NESTED RAIL LAPS OVER THE TERMINAL CONNECTOR. PLATE WASHERS ARE INSTALLED UNDER THE SPLICE NUTS AGAINST INSIDE OF CONNECTOR.  
**BRIDGE EXIT - DOWNSTREAM:** THE TERMINAL CONNECTOR LAPS OVER THE NESTED RAIL. PLATE WASHERS ARE INSTALLED UNDER THE BOLT HEAD AGAINST OUTSIDE OF CONNECTOR.

**ONLY FOR USE IN MAINTENANCE REPAIRS.**

**METAL BEAM GUARD FENCE TRANSITION (THRIE-BEAM TRANSITION) MBGF (TR) - 19**

FILE: mbgfr19.dgn	DN: TxDOT	CK: KM	DW: BD	CK: VP
© TxDOT NOVEMBER 2019	CONT	SECT	JOB	HIGHWAY
REVISIONS	6435	38	001	IH10, etc
	DIST	COUNTY		SHEET NO.
BMT	JEFFERSON, etc			69

Design Division Standard

DISCLAIMER: THE USE OF THIS STANDARD IS GOVERNED BY THE "TEXAS ENGINEERING PRACTICE ACT". NO WARRANTY OF ANY KIND IS MADE BY TXDOT FOR ANY PURPOSE WHATSOEVER. TXDOT ASSUMES NO RESPONSIBILITY FOR THE CONVERSION OF THIS STANDARD TO OTHER FORMATS OR FOR INCORRECT RESULTS OR DAMAGES RESULTING FROM ITS USE.

DATE: 2/28/2023  
 FILE: T:\BMTAO\01 - CSJ Project Files\6435-38-001MBGF 2024\Design\Design\MBGF.dgn

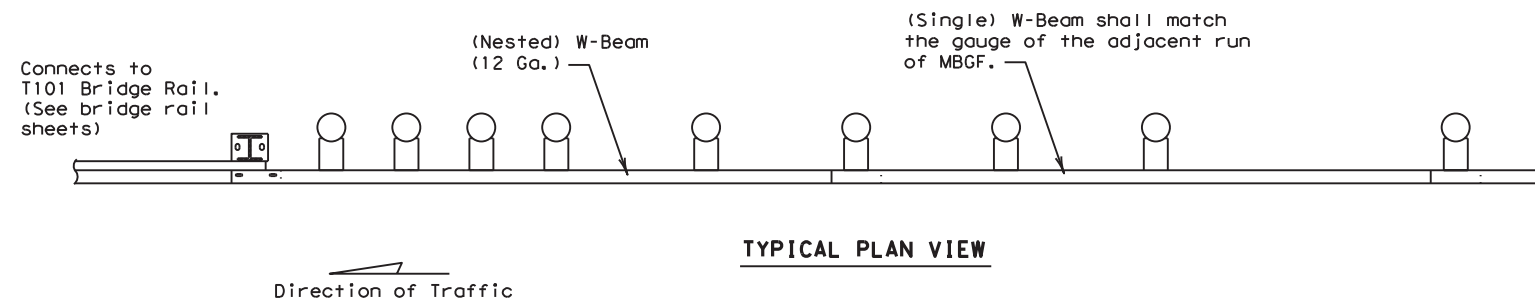

**TYPICAL PLAN VIEW**

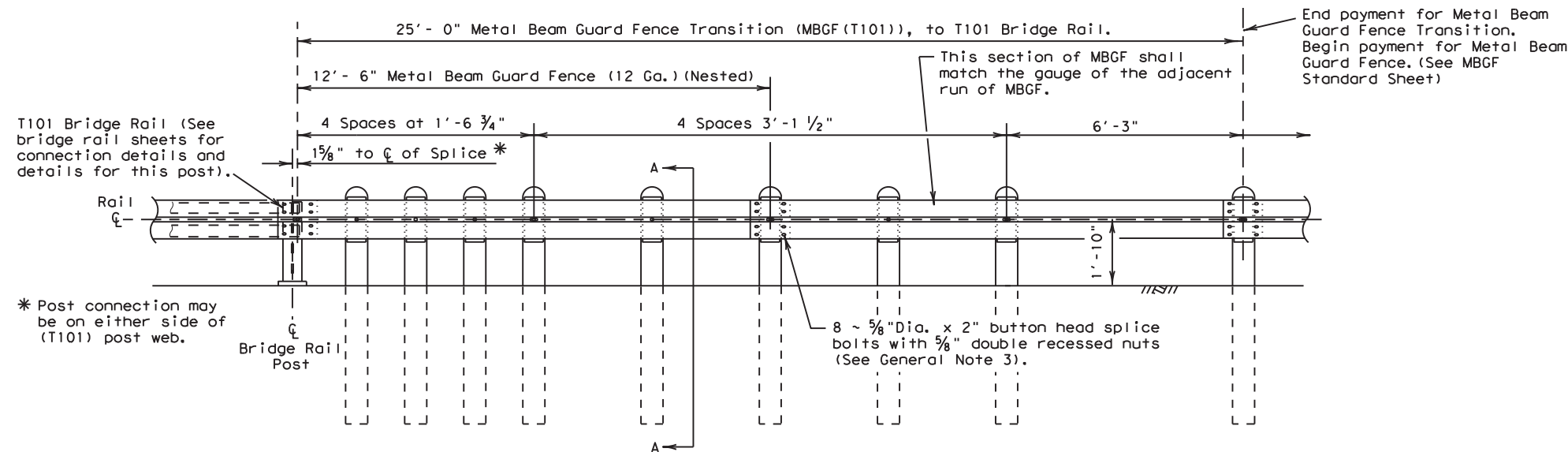

**TYPICAL ELEVATION VIEW**

\* Post connection may be on either side of (T101) post web.

- GENERAL NOTES**
- The type of post (round wood post, rectangular wood post, or steel post) will be shown elsewhere in the plans. The exact position of transitions shall be shown elsewhere in the plans or as directed by the Engineer.
  - Rail element shall meet the requirements of Item 540, "Metal Beam Guard Fence" except as modified on the plans.
  - Button head "post" bolts (ASTM A307) shall be of sufficient length to extend through the full thickness of the nut (ASTM A563) and the Type A 1 3/4" O.D. washer and not more than 1" beyond it. Button head "splice" bolts (ASTM A307) are 5/8" x 2" (at triple rail splices) with a 5/8" double recessed nuts (ASTM A563).
  - Fittings (bolts, nuts, and washers) shall be galvanized in accordance with Item 445, "Galvanizing." Fittings shall be subsidiary to the bid item requiring construction of the transition.
  - Crown will be widened to accommodate transitions.
  - If solid rock is encountered. See the MBGF standard sheet for proper installation guidance.
  - Posts shall not be set in concrete.
  - Unless otherwise shown in the plans, a composite material post and/or block that meets the requirements of DMS-7210, "Composite Material Posts and Blocks for Metal Beam Guard Fence" may be substituted for posts and/or blocks of similar dimensions. The Construction Division, TxDOT, maintains a Material Producer List (MPL) for producers of materials conforming to DMS-7210. Only producers on the MPL can furnish composite material posts and/or blocks.
  - Refer to MBGF Standard Sheet for additional details.

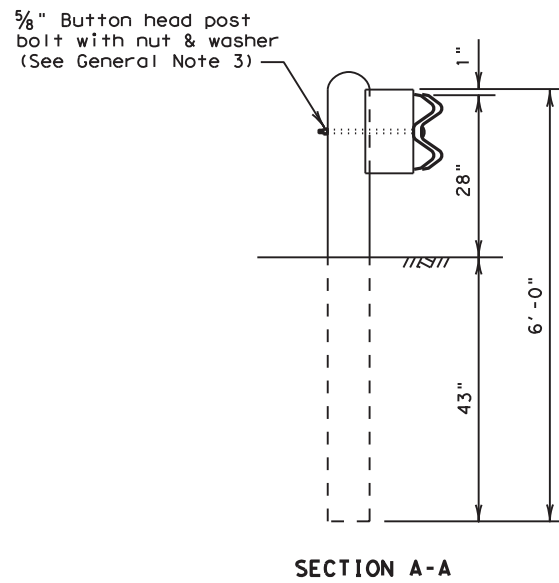

**SECTION A-A**

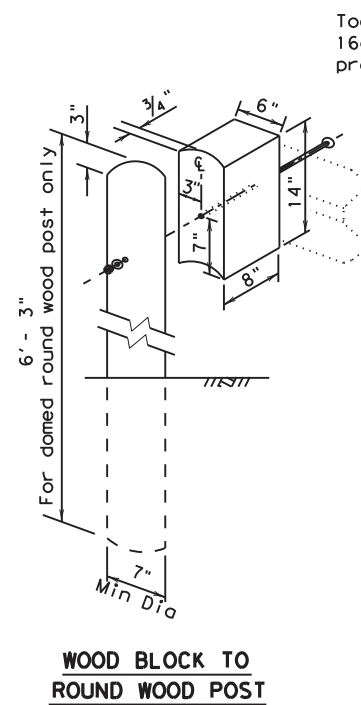

**WOOD BLOCK TO ROUND WOOD POST**

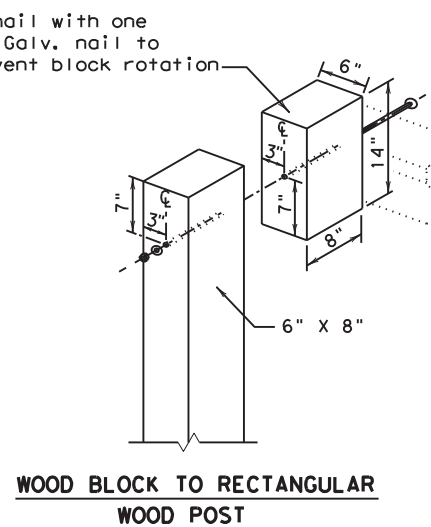

**WOOD BLOCK TO RECTANGULAR WOOD POST**

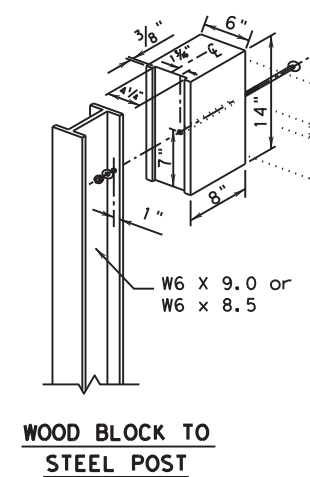

**WOOD BLOCK TO STEEL POST**

**ONLY FOR USE IN MAINTENANCE REPAIRS.**



**METAL BEAM GUARD FENCE TRANSITION (T101) (T101 BRIDGE RAIL) MBGF (T101) - 19**

FILE: mbgft10119.dgn	DN: TXDOT	CK: KM	DW: BD	CK: VP
© TXDOT NOVEMBER 2019	CONT	SECT	JOB	HIGHWAY
REVISIONS	6435	38	001	IH10, etc
DIST	COUNTY		SHEET NO.	
BMT	JEFFERSON, etc		70	

DISCLAIMER: THE USE OF THIS STANDARD IS COVERED BY THE "TEXAS ENGINEERING PRACTICE ACT". NO WARRANTY OF ANY KIND IS MADE BY TXDOT FOR ANY PURPOSE WHATSOEVER. TXDOT ASSUMES NO RESPONSIBILITY FOR THE CONVERSION OF THIS STANDARD TO OTHER FORMATS OR FOR INCORRECT RESULTS OR DAMAGES RESULTING FROM ITS USE.

DATE: 2/28/2023  
 FILE: T:\BMT\AO\01 - CSJ Project Files\6435-38-001\MBGF 2024\Design\DCN\gfmq.dgn

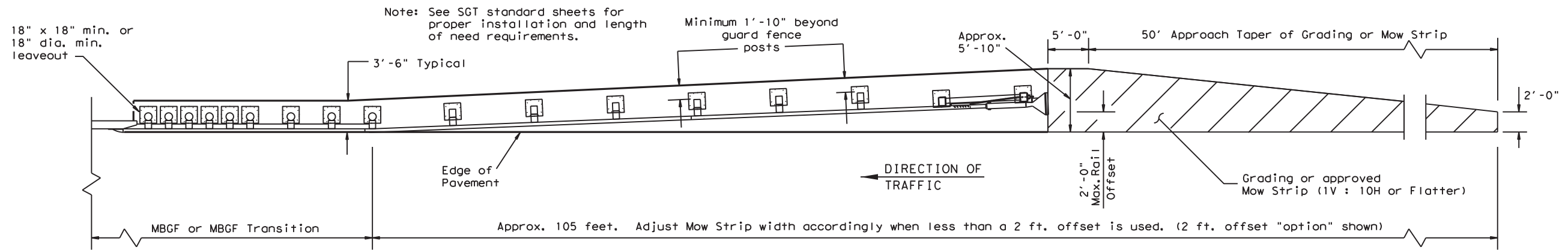

**GRADING AND MOW STRIP AT GUARDRAIL END TREATMENTS**

Note: Site Condition(s)  
 Site conditions may exist where grading is required for the proper installation of metal guard fence and end treatments.  
 Approach grading or mow strip may be decreased or eliminated. As directed by the Engineer.

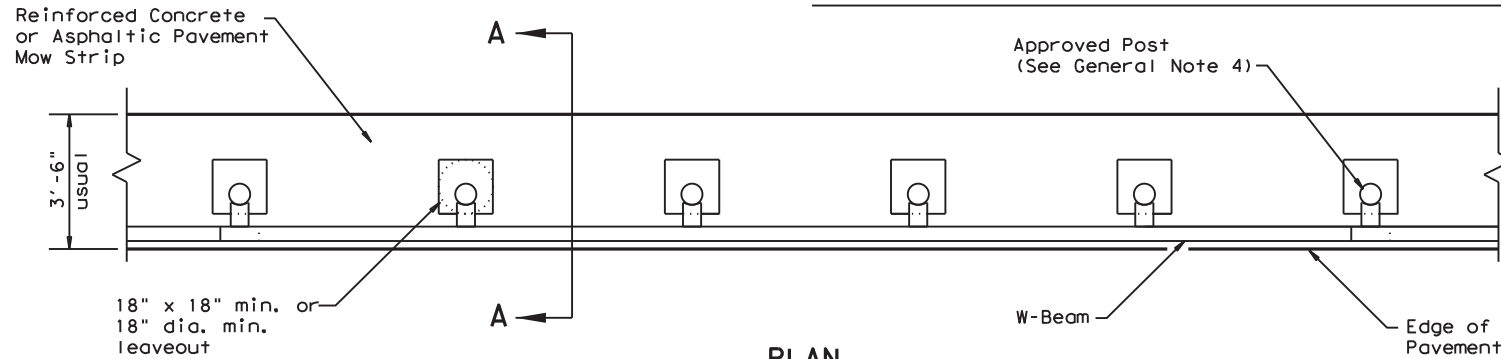

**PLAN**

Regular MBGF shown with Mow Strip

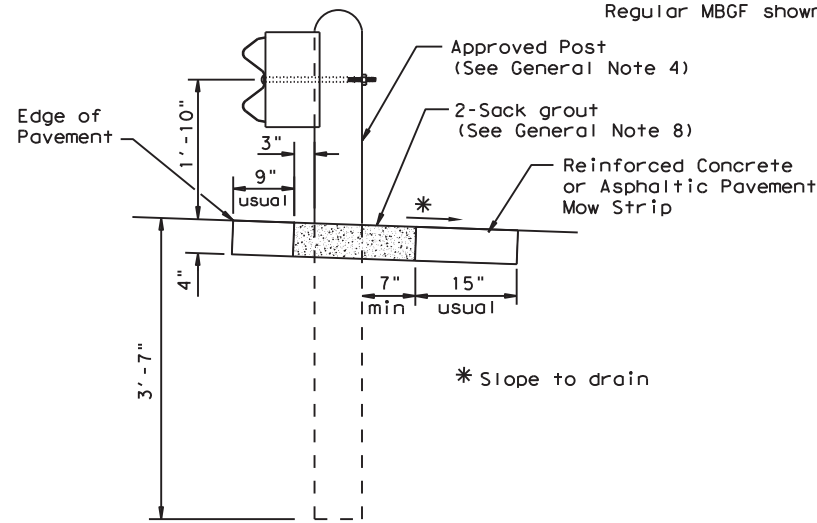

**SECTION A-A**

Typical

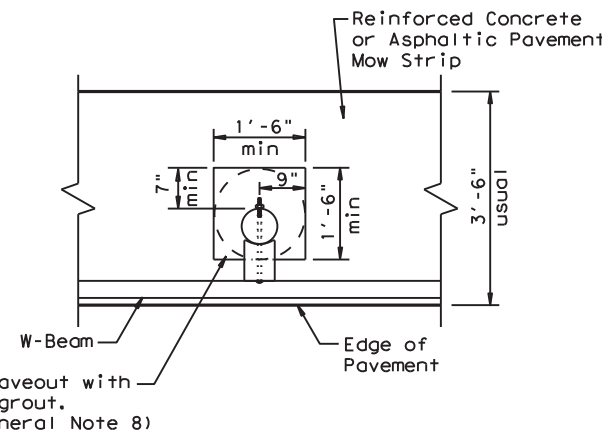

**MOW STRIP DETAIL**

Reinforced Concrete or Asphaltic Pavement Mow Strip with 18" x 18" or 18" dia. minimum leaveout.

**GENERAL NOTES**

1. This mow strip design is for use with metal beam guard fence, guard fence transitions, and guard fence end treatments (See SGT standards for proper SGT installation).
2. Mow strips shall be asphaltic pavement or reinforced concrete (wire mesh or synthetic fiber), as shown on the plans and will be paid for under the pertinent bid item of work. Asphaltic pavement shall meet the requirements of the item, and be placed in accordance with the pertinent bid item as shown on the plans. Reinforced concrete shall be placed in accordance with Item 432, "Riprap." The use of the synthetic fiber in lieu of steel reinforcing is acceptable, provided the fiber producer is on the Department Material Producer List (MPL), maintained by TxDOT, Construction Division.
3. The leaveout behind the post shall be a minimum of 7".
4. The type of approved post will be shown elsewhere in the plans. See the applicable standard sheets for additional details and information.
5. Other curb placement options may be used. Curbs are not considered part of the mow strip and will be paid for under other pertinent bid item.
6. Depth of mow strip will be 4".
7. The limits of payment for asphaltic pavement or reinforced concrete will include leaveouts for posts.
8. The leave-outs shall be filled with no more than a 2-sack grout mixture (1 part cement, 5 parts water, and 14 parts sand by volume) with a 28-day compressive strength of approximately 120 psi or less. Provide grout of a consistency that will flow into and completely fill all voids. Due to auger size, larger leave-out dimensions are acceptable from both an impact performance and maintenance repair standpoint (Suggested maximum leave-out of 20"). Payment for furnishing and placing the grout mixture will be subsidiary to the pay item of rip rap mow strip.

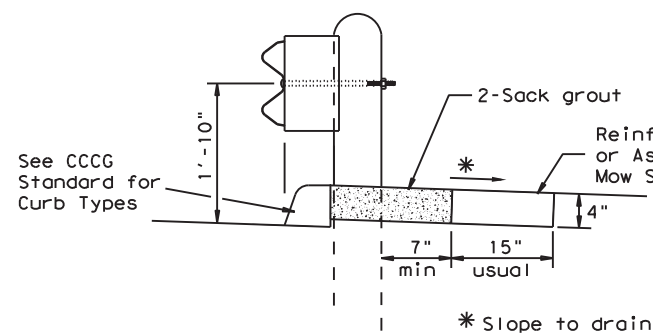

**CURB OPTION (1)**

This option will increase the post embedment through out the system.

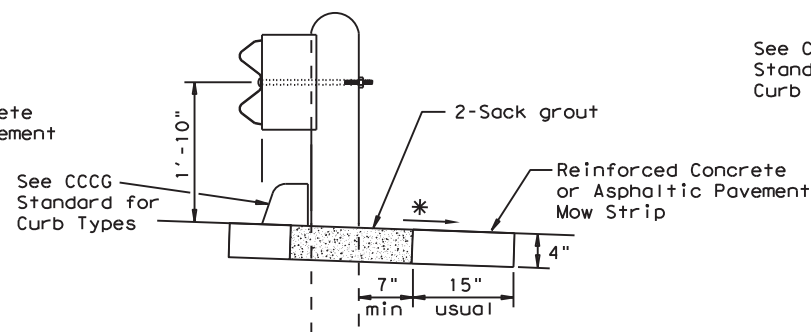

**CURB OPTION (2)**

Curb shown on top of mow strip

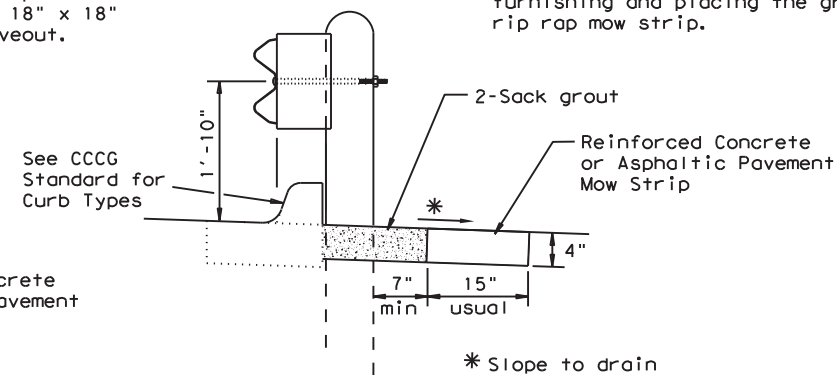

**CURB OPTION (3)**

**ONLY FOR USE IN MAINTENANCE REPAIRS.**



**METAL BEAM GUARD FENCE (MOW STRIP) MBGF (MS) - 19**

FILE: mbgfms19.dgn	DN: TxDOT	CK: KM	DW: TXDOT	CK: CL
© TxDOT NOVEMBER 2019	CONT	SECT	JOB	HIGHWAY
REVISIONS	6435 38		001	IH10, etc
DIST	COUNTY	SHEET NO.		
BMT	JEFFERSON, etc	71		

DISCLAIMER: THE USE OF THIS STANDARD IS COVERED BY THE "TEXAS ENGINEERING PRACTICE ACT". NO WARRANTY OF ANY KIND IS MADE BY TXDOT FOR ANY PURPOSE WHATSOEVER. TXDOT ASSUMES NO RESPONSIBILITY FOR THE CONVERSION OF THIS STANDARD TO OTHER FORMATS OR FOR INCORRECT RESULTS OR DAMAGES RESULTING FROM ITS USE.

DATE: 2/28/2023 8:52:30 AM  
 FILE: T:\BMT\AO\01 - CSJ Project Files\6435-38-001\MBGF 2024\Design\DN\g&f&mg.dgn

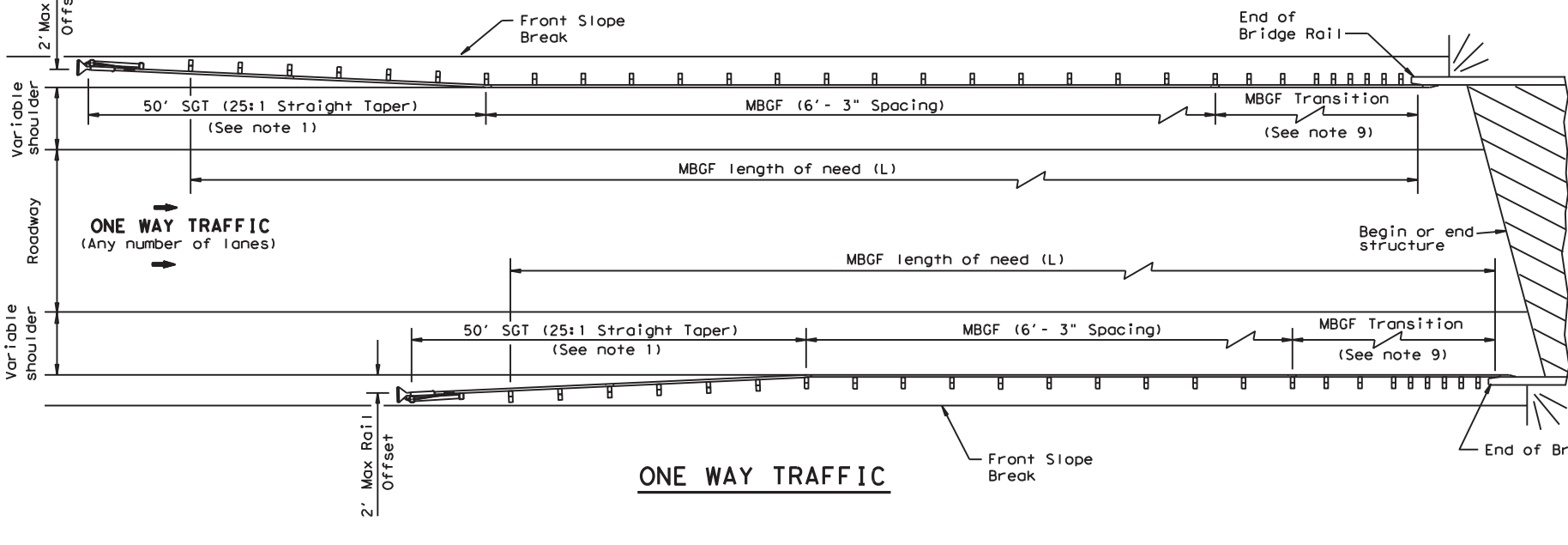
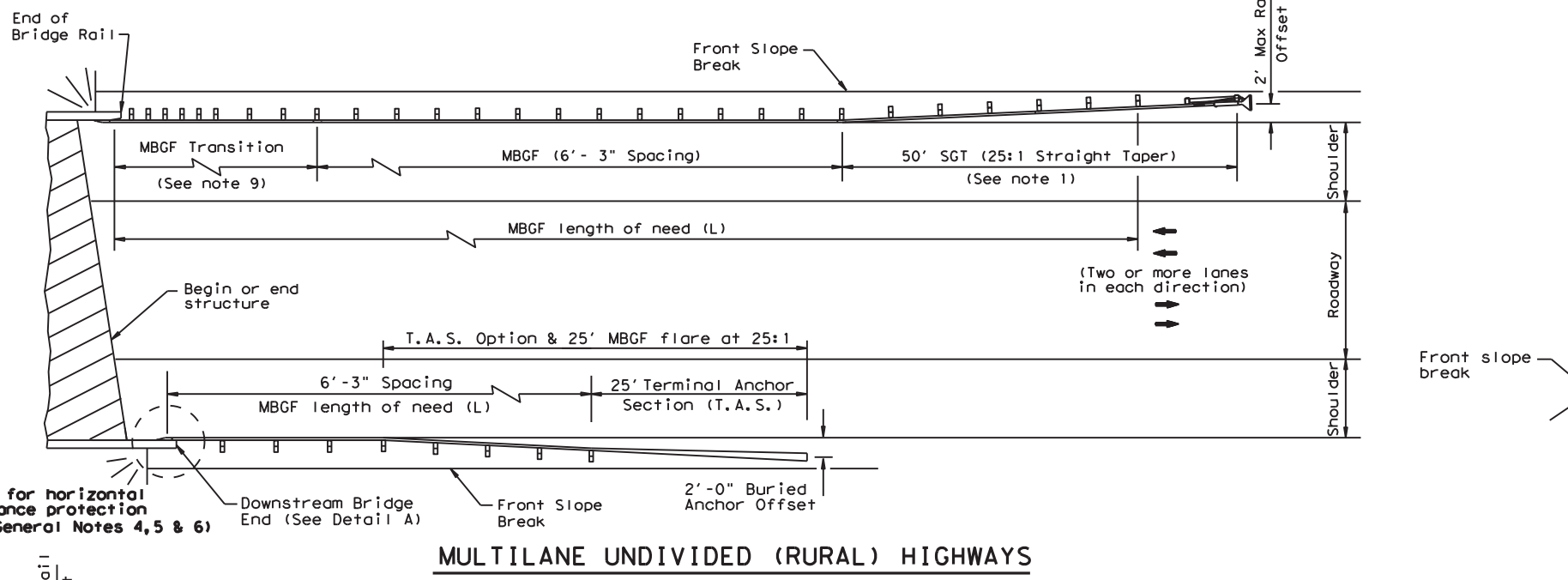
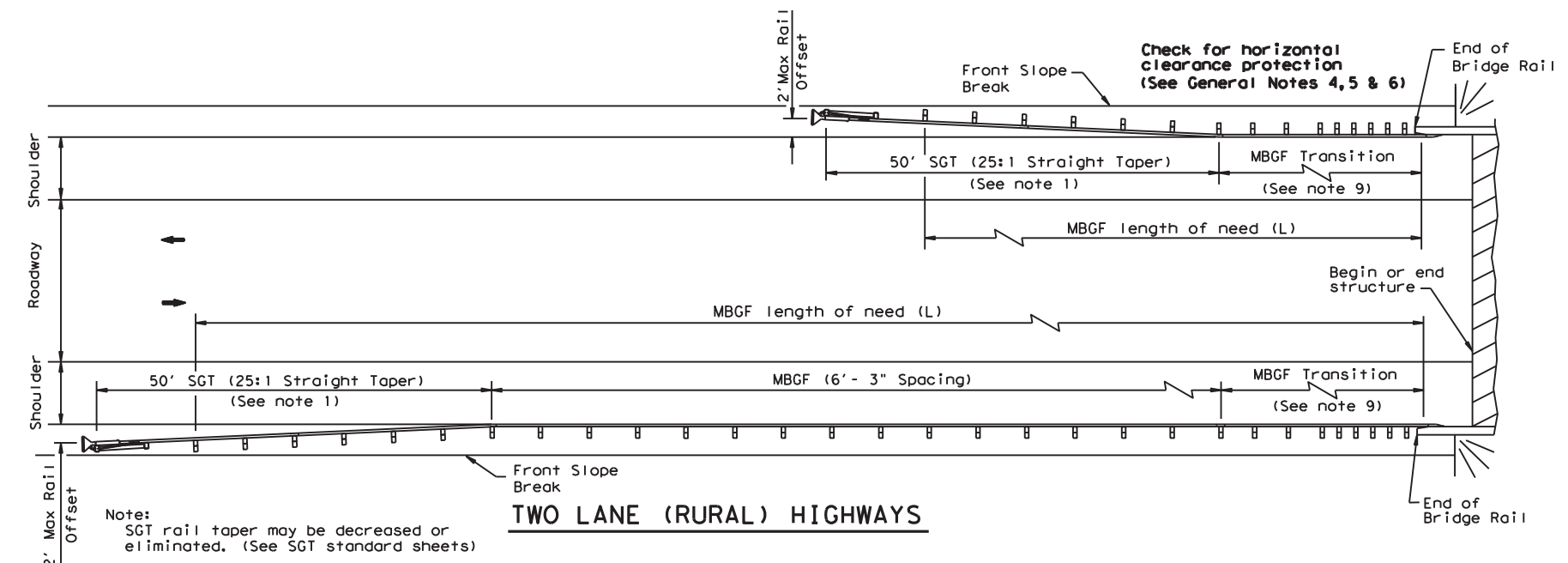

**GENERAL NOTES**

1. For more detail: See MBGF, SGT, and MBGF Transition standard sheets.
2. Quantities of metal beam guard fence (MBGF) at individual bridge ends are shown elsewhere in plans.
3. Use average daily traffic (ADT) for the current year to determine MBGF length of need in accordance with the Roadway Design Manual unless otherwise specified. Where significant traffic volume growth is anticipated on low volume (0-750 ADT) highways, use length determinations for the higher volume category.
4. MBGF may not be required to shield departure end of bridge unless other obstacles within the horizontal clearance limits or opposing traffic indicate a MBGF consideration.
5. Terminal anchor sections (TAS) are only for downstream end anchorage use, outside the horizontal clearance area of opposing traffic.
6. Direct connection of MBGF (at 6'-3" post spacing without transition) to concrete rail are only for downstream rail connections outside the horizontal clearance area of opposing traffic. (See Detail A)
7. The crown shall be widened to accommodate MBGF. Typically the "front slope" break should be 2'-0" from the back of the MBGF post. This applies to new construction on new alignment or where existing roadway cross section is to be widened to increase roadway width. This does not apply to rehabilitation work where existing roadway crown width is to be retained (See Typical Cross Section at MBGF).
8. For restrictive bridge widths: The MBGF should be properly transitioned from the existing bridge rail to the adjoining MBGF (See MBGF Transition Standards). Metal beam guard fence at these bridge location(s) shall be flared at the rate of 25:1 or flatter, and be of the length necessary to locate the terminal end at the 2 ft. "maximum" offset from the shoulder edge.
9. Transition length and post spacing will vary depending on the transition type. Transition type will be shown elsewhere in the plans.

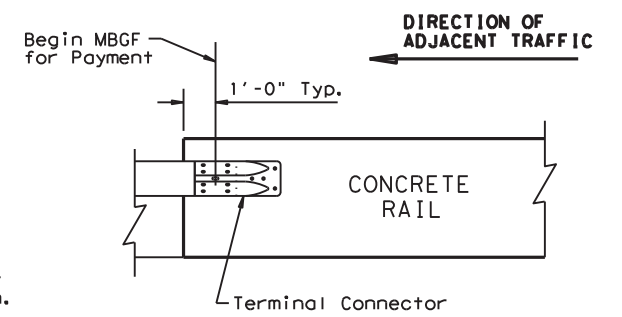
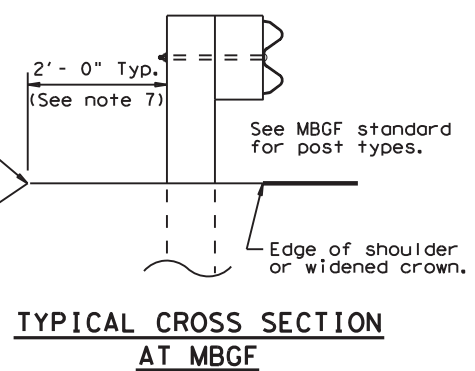

All rail elements shall be lapped in the direction of adjacent traffic.

**ONLY FOR USE IN MAINTENANCE REPAIRS.**

Texas Department of Transportation  
 Design Division Standard

**BRIDGE END DETAILS  
 (28" METAL BEAM GUARD FENCE  
 APPLICATIONS TO RIGID RAILS)  
 BED (28) - 19**

FILE: bed2819.dgn	DN: TXDOT	CK: KM	DW: BD	CK: VP
© TXDOT NOVEMBER 2019	CONT	SECT	JOB	HIGHWAY
REVISIONS	6435 38		001	IH10, etc
	DIST	COUNTY		SHEET NO.
	BMT	JEFFERSON, etc		72



**Preferred Installation:** Locate post #2 away from nearest traffic.  
System has been successfully tested with opposite installation.

**Length-of-Need Cass Cable Terminal (CCT):**  
**Departure Installation:** Length-of-Need: 44'-9" (At Post #8)  
**Approach Installation:** Length-of-Need: 19'-9" (12" Post Post #4)

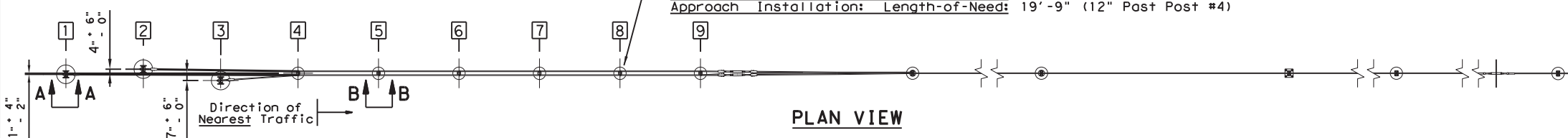

**PLAN VIEW**

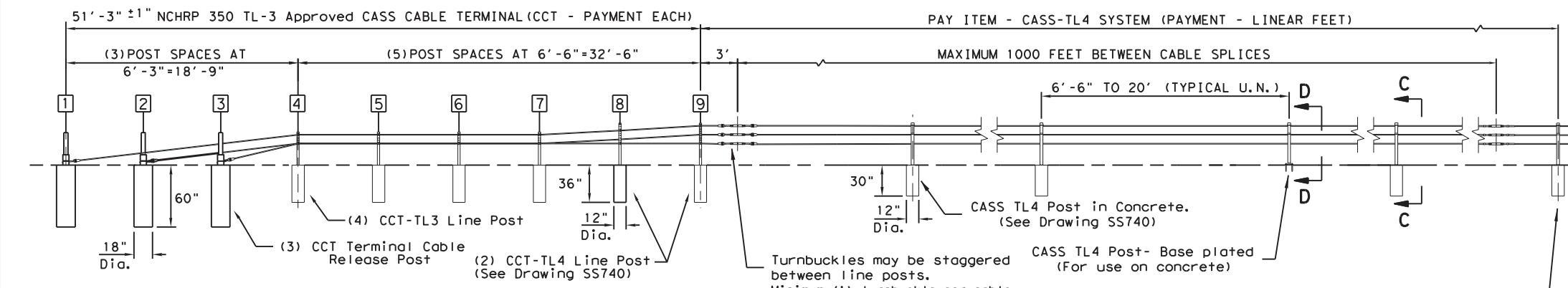

**ELEVATION VIEW (TYPICAL LAY-OUT)**

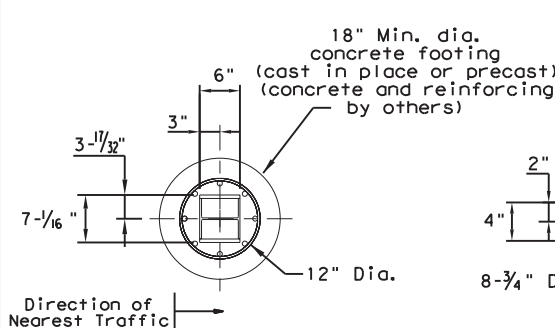
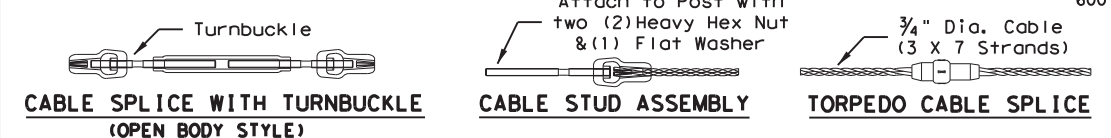

**SECTION E-E**

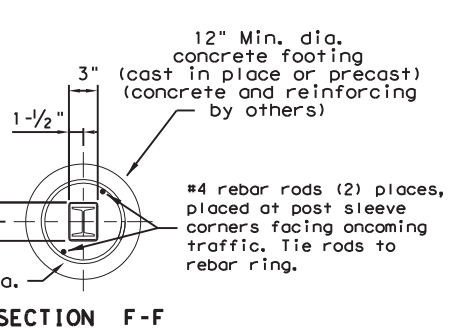

**SECTION F-F**

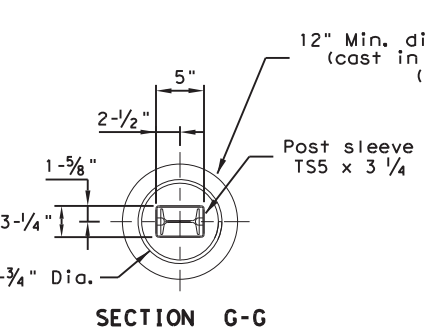

**SECTION G-G**

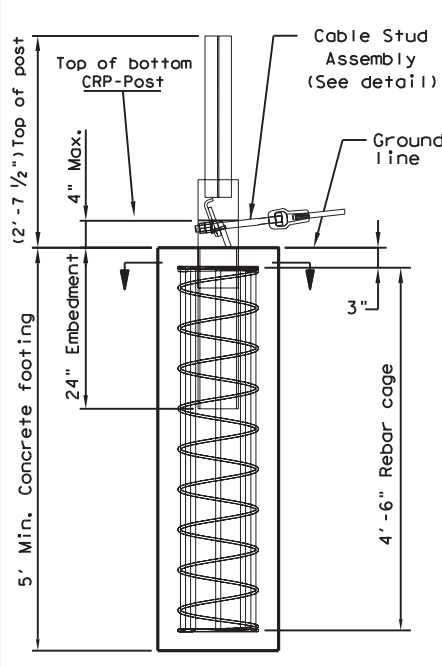

**VIEW A-A (CABLE RELEASE POST 1-3)**

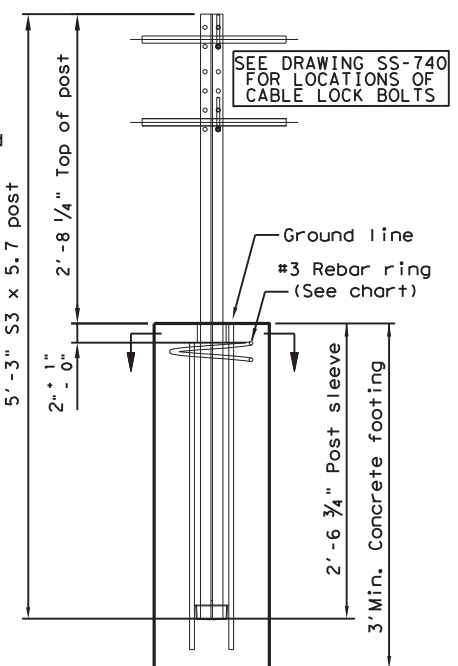

**VIEW B-B (TERMINAL LINE POST 4-7)**

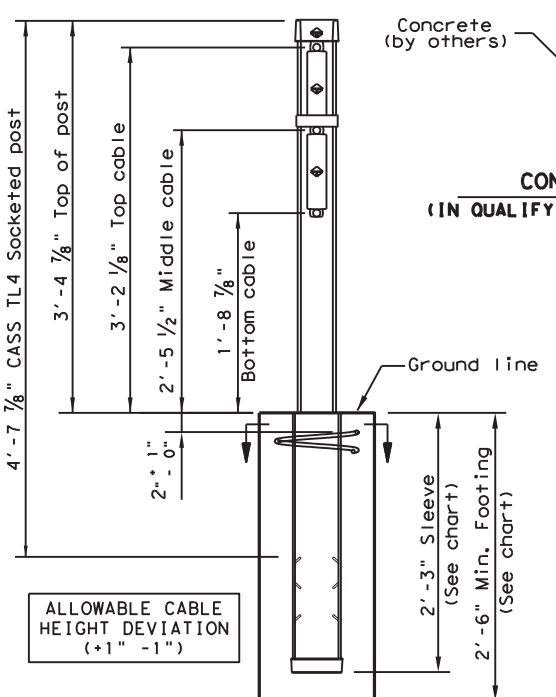

**SECTION C-C (SOCKETED POST)**

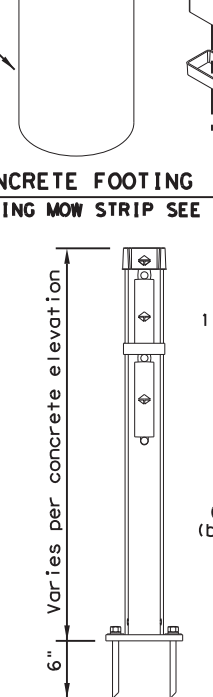

**SECTION D-D (BASE PLATED POST)**

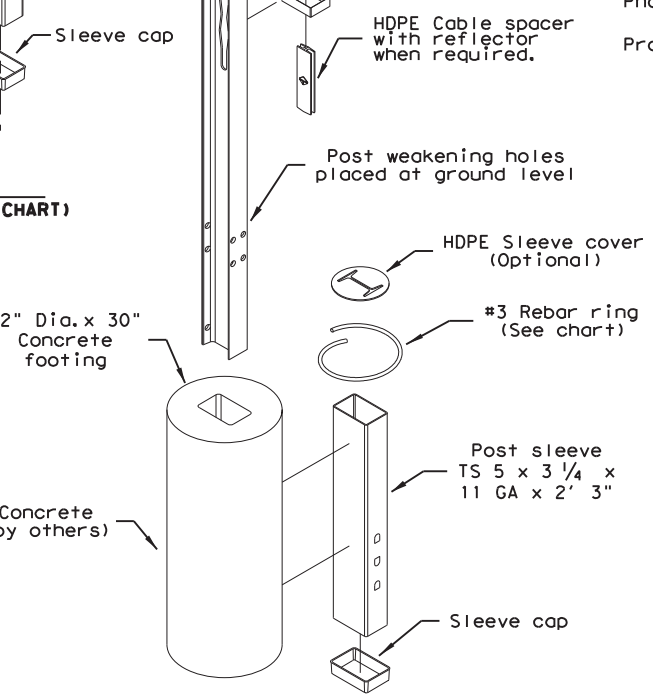

**STANDARD POST & CONCRETE FOOTING (SOCKETED POST)**

- GENERAL NOTES**
- This drawing is a general overview of CASS TL-4 Barrier System. See SS-740 (latest version) for specific details of CASS cable terminal (CCT) and cable safety system (CASS) requirements, proper installation, options and specification.
  - CASS is designed for bi-directional traffic flows and can be installed on either side of the median. Contact Trinity (800-527-6050) or consult the design, installation, or repair manual(s) for additional information.
  - All concrete for CASS footings shall be TxDOT class A. If class A or stronger concrete is utilized for the mowstrip, please see chart below for allowable footing depth and sleeve deviations.
  - All posts shall be socketed unless otherwise specified. All cables shall be pre-stretched unless otherwise specified.
  - For payment see Special Specification "Cable Barrier System".
  - CASS-TL4 shall be installed on shoulders or medians with slopes of 6:1 or flatter without obstructions, depressions, etc. That may significantly affect the stability of an erring vehicle. Grading of site and/or appropriate fill materials may be required. The designer/installer shall "Flatten" or "Round" various topographical inconsistencies that could interfere with the ability of the installer to consistently maintain the design height (in relation to the terrain) of the cables. Please consult manual(s) and/or TxDOT Memo(s) for installations in "Ditch Sections".
  - CASS TL-4 post spacing may be modified to avoid obstacles that conflict with the installation of cass-tl4 line posts or to reduce deflection on radiuses. No post space can exceed the maximum post TxDOT space limit of 20'. Reducing or increasing post spacing affects deflection. CASS TL-4 may be laterally transferred at a rate not to exceed 30:1.
  - Post foundations may be drilled through existing pavement. Please see line post foundation chart for minimum footing requirements in various applications.
  - For aesthetic purposes Trinity recommends all sleeves, driven posts, and lower cable release posts to be installed reasonably plumb (approximately 1/8" per foot).
  - CASS TL-4 shall be installed in well-drained, compacted, NCHRP Report 350 Standard soil. If soil does not meet this classification, if solid rock/concrete is encountered below grade or if soil is susceptible to severe freeze/thaw cycles, please contact Trinity about alternate footing design(s). Trinity suggests the use of "Mow strips" for erosion prevention and ease of maintenance / installation.
  - See the Texas MUTCD for proper "Barrier" Delineation.

MOW STRIP DETAIL*			CONCRETE FOOTING CHART		
MOW STRIP	DEPTH	WIDTH	FOOTING	TUBE SLEEVE	REBAR RING
NONE			30" Min.	27" Min.	YES
HMA	6" Min.	3' Min.	27" Min.	15" Min.	NO
HMA	8" Min.	3' Min.	24" Min.	15" Min.	NO
RC	3" Min.	3' Min.	24" Min.	15" Min.	NO

Chart does not apply to Terminal Posts 1 thru 9.  
\* Mow strip or pavement.  
HMA = Hot Mix Asphalt (Not Recycled Asphalt Pavement).  
RC = Reinforced Concrete (TxDOT Class A Minimum).

Trinity Highway Products, LLC.  
2525 Stemmons Freeway  
Dallas, TX 75207  
Phone: (800) 644-7976  
Product. INFO@TRIN.NET

CABLE TENSION CHART	
FAHRENHEIT DEGREES	PRE-STRETCHED LB / FORCE
-10	7300
0	7000
10	6600
20	6300
30	6000
40	5600
50	5300
60	5000
70	4600
80	4300
90	4000
100	3600
110	3300
120	3000
130	2700
140	2500
150	2300

Allowable deviation from chart in tangent sections: +800, -200 pounds/force. Cable tension readings are typically higher in curved cable sections.

Texas Department of Transportation  
Design Division Standard

**TRINITY CABLE SAFETY SYSTEM (TL-4)**

**CASS (TL4) - 14**

FILE: casst1414.dgn	DN: TxDOT	CK: RM	DW: VP	CK:
©TxDOT: March 2014	CONT: 6435	SECT: 38	JOB: 001	HIGHWAY: IH10, etc
REVISIONS:	DIST: BMT	COUNTY: JEFFERSON, etc	SHEET NO. 73	

DISCLAIMER: The use of this standard is governed by the "Texas Engineering Practice Act". No warranty of any kind is made by TxDOT for any purpose whatsoever. TxDOT assumes no responsibility for the conversion of this standard to other formats or for incorrect results or damages resulting from its use.

DATE: FILE:

DISCLAIMER: The use of this standard is governed by the "Texas Engineering Practice Act". No warranty of any kind is made by TxDOT for any purpose whatsoever. TxDOT assumes no responsibility for the conversion of this standard to other formats or for incorrect results or damages resulting from its use.

DATE: FILE:

### REFLECTOR UNIT SIZES FOR DELINEATORS AND OBJECT MARKERS

### DELINEATORS

### D & OM DESCRIPTIVE CODES

DEVICE	SIZE 1	SIZE 2	SIZE 3	SIZE 4

DEVICE	SINGLE	DOUBLE

<b>INSTL DEL ASSM</b> (D-XX)SZ X (XXXX)XXX (XX) NUMBER OF REFLECTORS S = Single D = Double COLOR OF REFLECTORS W = White Y = Yellow R = Red REFLECTOR UNIT SIZE 1 or 2 TYPE OF POST OR DELINEATOR WC = Wing Channel Post YFLX = Yellow Flexible Post WFLX = White Flexible Post BRF = Barrier Reflector TYPE OF MOUNT GND = Embedded (drivable or set in concrete) CTB = Concrete Barrier Mount GF1 or GF2 = Guard Fence Attachment SRF = Surface Mount
--

SHEETING	Yellow, White or Red Type B or C reflective sheeting
NOTE	1. Size 1 and 4 - Direct applied reflective sheeting for use on flexible post (fix). 2. Size 2 and 3 - For use on wing channel (wc) post only. Use approved metal, plastic or fiberglass backplate with 17/64" mounting holes.

SHEETING	Yellow, White or Red Type B or C Reflective Sheeting			
POST TYPE	WC	YFLX, WFLX	WC	YFLX, WFLX
MOUNT TYPE	GND	GND, SRF	GND	GND, SRF

<b>INSTL OM ASSM</b> (OM-XX) (XXXX)XXX (XX) TYPE OF OBJECT MARKER 1, 2, 3, or 4 NUMBER OF REFLECTORS OR DIRECTION X = 3-Size 2 reflector units (Type 2 only) Y = 1-Size 3 reflector unit (Type 2 only) Z = 3-Size 1 or 1-Size 4 reflector unit(s) (Type 2 only) L = Left Side (Type 3 Object Marker only) R = Right Side (Type 3 Object Marker only) C = Center (Type 3 Object Marker only) TYPE OF POST WC = Wing Channel Post WFLX = White Flexible Post TWT = Thin Walled Tubing TYPE OF MOUNT GND = Embedded (drivable) SRF = Surface Mount WAS = Wedge Anchor Steel WAP = Wedge Anchor Plastic DIRECTION If Required BI = Bi-Directional
--

### OBJECT MARKERS

DEVICE	Type 1 (OM-1)	Type 2 (OM-2)			Type 3 (OM-3)			Type 4 (OM-4)
	OM-1	OM-2X	OM-2Y	OM-2Z	OM-3L	OM-3R	OM-3C	OM-4
SHEETING	Yellow-Type B <sub>FL</sub> or C <sub>FL</sub> Sheeting	Yellow - Type B or C Sheeting			Alternating acrylic black and retroreflective yellow - Type B <sub>FL</sub> or C <sub>FL</sub> Sheeting			Red -Type B <sub>FL</sub> or C <sub>FL</sub> Sheeting
POST TYPE	TWT	WC	WC	WFLX	TWT			TWT
MOUNT TYPE	WAS, WAP	GND	GND	GND, SRF	WAS, WAP			WAS, WAP

<b>DEPARTMENTAL MATERIAL SPECIFICATIONS</b> FLEXIBLE DELINEATOR & OBJECT MARKER POSTS (EMBEDDED & SURFACE MOUNT TYPES) DMS-4400 SIGN FACE MATERIALS DMS-8300 DELINEATORS, OBJECT MARKERS AND BARRIER REFLECTORS DMS-8600
---

### BARRIER REFLECTORS (BRF)

### CHEVRONS

### ONE DIRECTION LARGE ARROW

DEVICE	GF1	GF2	CTB
NOTE	1. Barrier reflectors shall meet the requirements of DMS 8600. 2. Approved Barrier Reflectors are listed on the "Barrier Reflectors" Material Producer List at: www.txdot.gov.		
SHEETING	Yellow, White, Red		
NOTE	1. Reflective sheeting shall have a minimum dimension of 3 inches and minimum surface area of 9 square inches.		

DEVICE	W1-8			
SIZE (W x L)	18" x 24" (Conventional)	24" x 30" (Conventional Oversize)	30" x 36" (Expressway)	36" x 48" (Freeway)
MOUNTING HEIGHT	4'-0" or 7'-0"			
NOTE	1. CHEVRON (W1-8) signs and ONE DIRECTION LARGE ARROW (W1-6) Signs shall be installed per Sign Mounting Details (SMD) Standard Sheets and paid under Item 644 (Small Roadside Sign Assemblies). 2. When there is a need to increase conspicuity, the Texas version of the ONE DIRECTION LARGE ARROW sign (W1-9T) may be used instead of the ONE DIRECTION LARGE ARROW (W1-6).			

DEVICE	W1-6	
SIZE (W x L)	48" x 24" (Conventional)	60" x 30" (Expressway & Freeway)
MOUNTING HEIGHT	7'-0"	

**NOTE:**  
 Delineator and object marker substrates and sign substrates shall be 0.080" Aluminum sign blank to conform to ASTM B-209 Alloy 6061-T6 or approved alternative.

Texas Department of Transportation		Traffic Safety Division Standard	
<b>DELINEATOR &amp; OBJECT MARKER MATERIAL DESCRIPTION</b> <b>D &amp; OM(1)-20</b>			
FILE: dom1-20.dgn	DW: TXDOT	CK: TXDOT	CR: TXDOT
© TXDOT August 2004	CONT	SECT	JOB
REVISIONS	6435	38	001
10-09 3-15	DIST	COUNTY	SHEET NO.
4-10 7-20	BMT	JEFFERSON, etc	74

DISCLAIMER: The use of this standard is governed by the "Texas Engineering Practice Act". No warranty of any kind is made by TxDOT for any purpose whatsoever. TxDOT assumes no responsibility for the conversion of this standard to other formats or for incorrect results or damages resulting from its use.

**POST TYPE AND SUPPORT FOUNDATION DETAILS**

**TYPE OF BARRIER MOUNTS**

**WING CHANNEL (WC)**

**FLEXIBLE POSTS (YFLX, WFLX)**

**WEDGE ANCHOR SYSTEMS**

**GUARD FENCE ATTACHMENT**

**GND**

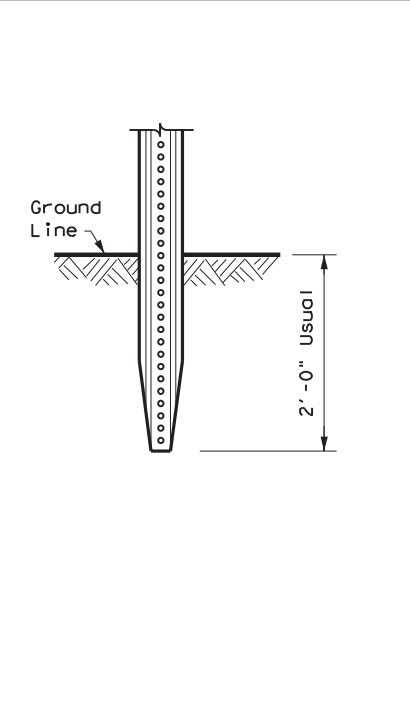

**GND**

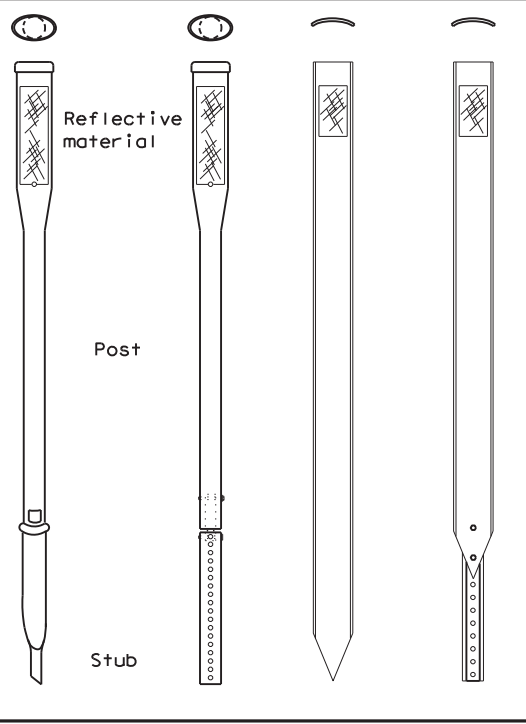

**SRF**

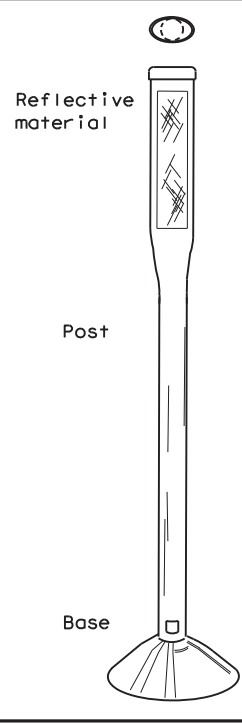

**WAS**

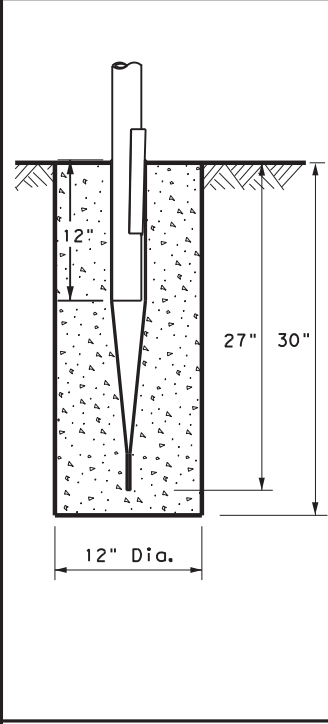

**WAP**

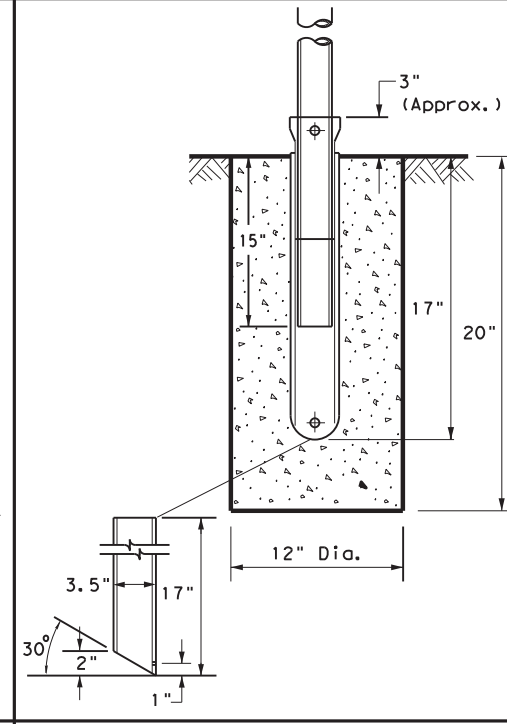

**GF 1**

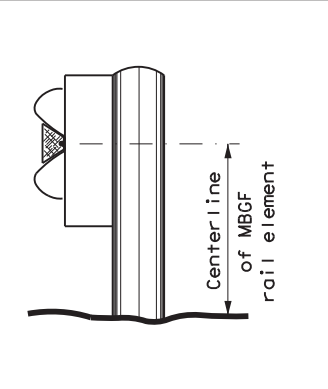

**GF 2**

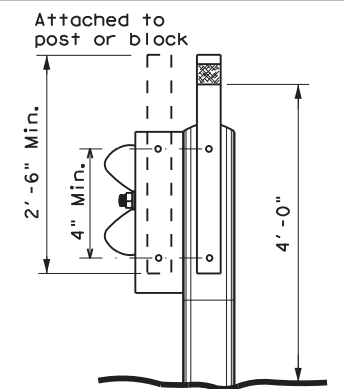

**NOTES**

1. Embedded Wing Channel (WC) post option may be used for Type 2 Object Markers and Delineators only.
2. 1.12 lbs/ft steel per ASTM A 1011 SS Gr. 50, or ASTM A499.

**NOTES**

1. See "Flexible Delineator and Object Marker Posts" Material Producer List for approved devices.
2. Install per manufacturer's recommendations.
3. Post length may vary to meet field conditions.
4. When using yellow delineators with flexible posts to separate opposing direction of travel, such as centerline or median use, the flexible posts shall be yellow.

**NOTE**

1. Install per manufacturer's recommendations.

**CONCRETE TRAFFIC BARRIER (CTB)**

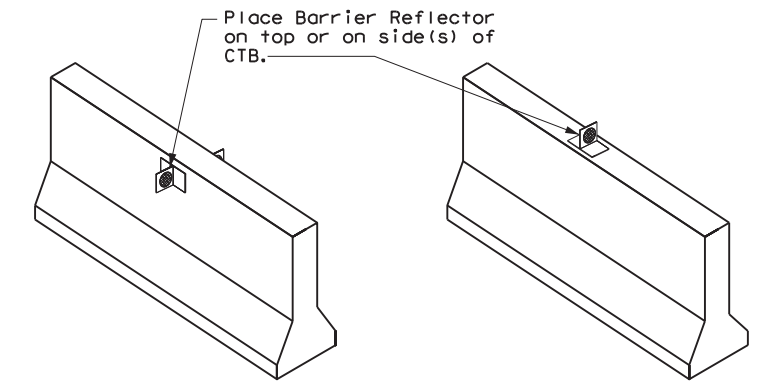

**GENERAL NOTES**

1. Place delineators on a section of roadway at a consistent distance from the edge of pavement.
2. Where a restriction prevents consistent placement from the pavement edge, place the affected object markers in line with the innermost edge of the obstruction.
3. When Type 2 object markers and delineators are more than 8'-0" from the edge of the pavement, it may not be possible to maintain a height of approximately 4'-0". If this is the case, place the object marker or delineator as close to the desired height as possible.
4. Install all delineators, object markers and barrier reflectors in accordance with the manufacturer's recommendation.
5. Barrier reflectors should be installed a minimum of 18 inches above the edge of the pavement surface.
6. Diagonal stripes on Type 3 object markers shall slope down toward the intended travel lane.

**TYPES 1,3, AND 4 OBJECT MARKERS AND CHEVRONS**

**CHEVRONS AND ONE DIRECTION LARGE ARROW SIGN**

**DELINEATORS AND TYPE 2 OBJECT MARKERS**

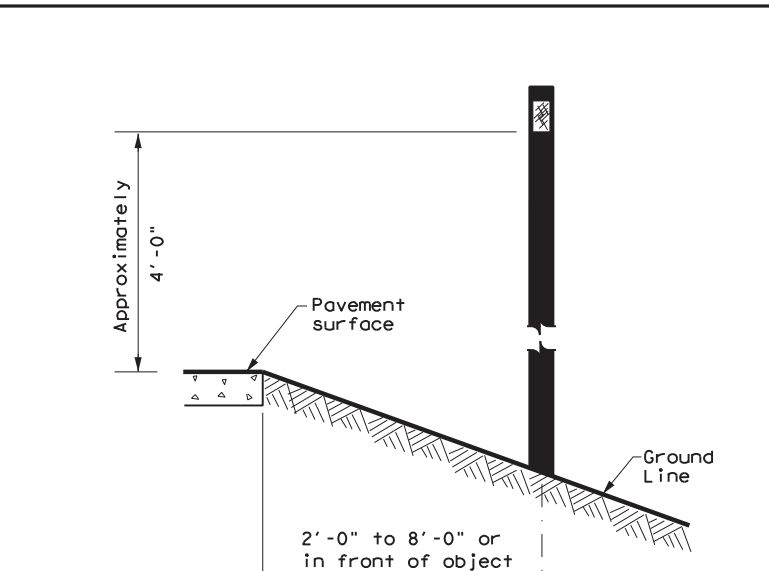
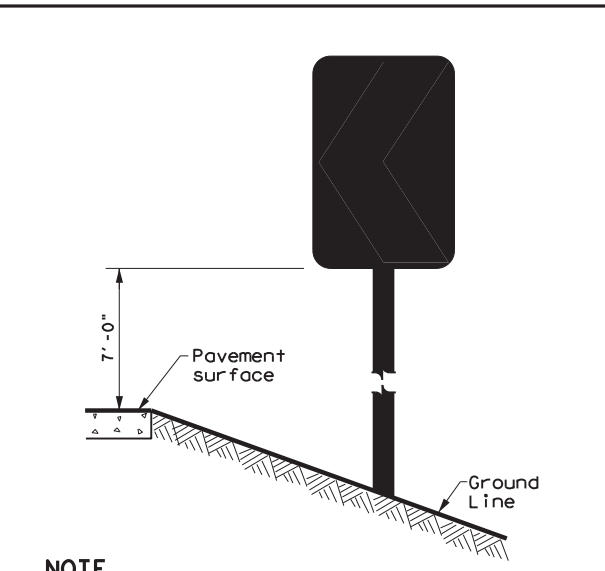
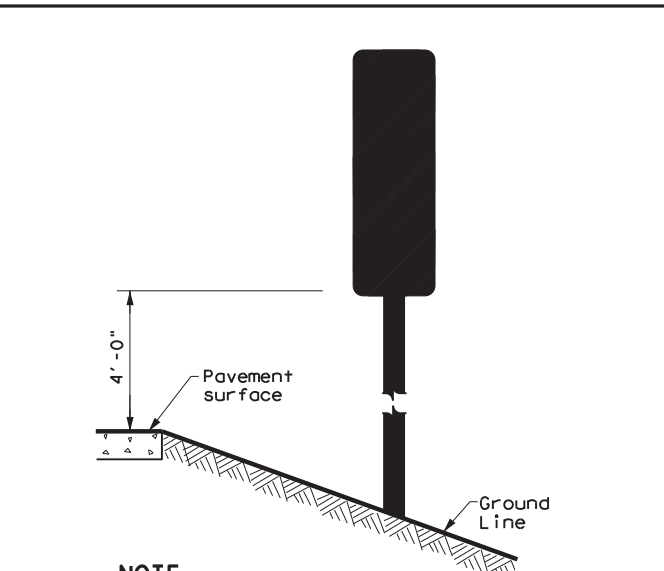

**NOTE**

Mounting at 4 feet to the bottom of the chevron is permitted for chevrons that will not exceed a height of 6'-6" to the top of the chevron (sizes 24" x 30" and smaller)

**NOTE**

Chevrons 30" x 36" and larger shall be mounted at a height of 7' to the bottom of the chevron. Chevron sign and ONE DIRECTION LARGE ARROW sign (W1-9T) shall be installed per SMD standard sheets and paid under item 644.

See general notes 1, 2 and 3.



**DELINEATOR & OBJECT MARKER INSTALLATION**

**D & OM(2)-20**

FILE: dom2-20.dgn	DN: TxDOT	CK: TxDOT	DW: TxDOT	CR: TxDOT
© TxDOT August 2004	CONT	SECT	JOB	HIGHWAY
REVISIONS	6435	38	001	IH10, etc
10-09 3-15	DIST	COUNTY		SHEET NO.
4-10 7-20	BMT	JEFFERSON, etc		75

DATE:  
FILE:

### MINIMUM WARNING DEVICES AT CURVES WITH ADVISORY SPEEDS

Amount by which Advisory Speed is less than Posted Speed	Curve Advisory Speed	
	Turn (30 MPH or less)	Curve (35 MPH or more)
5 MPH & 10 MPH	• RPMs	• RPMs
15 MPH & 20 MPH	• RPMs and One Direction Large Arrow sign	• RPMs and Chevrons; or • RPMs and One Direction Large Arrow sign where geometric conditions or roadside obstacles prevent the installation of chevrons.
25 MPH & more	• RPMs and Chevrons; or • RPMs and One Direction Large Arrow sign where geometric conditions or roadside obstacles prevent the installation of chevrons	• RPMs and Chevrons

### SUGGESTED SPACING FOR DELINEATORS ON HORIZONTAL CURVES

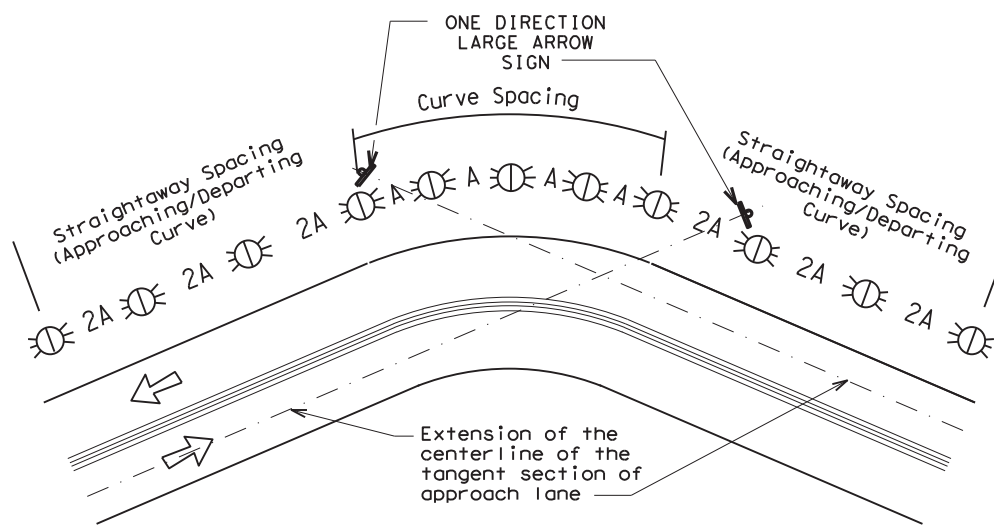

**NOTE**

ONE DIRECTION LARGE ARROW (W1-6) sign should be located at approximately and perpendicular to the extension of the centerline of the tangent section of approach lane.

### SUGGESTED SPACING FOR CHEVRONS ON HORIZONTAL CURVES

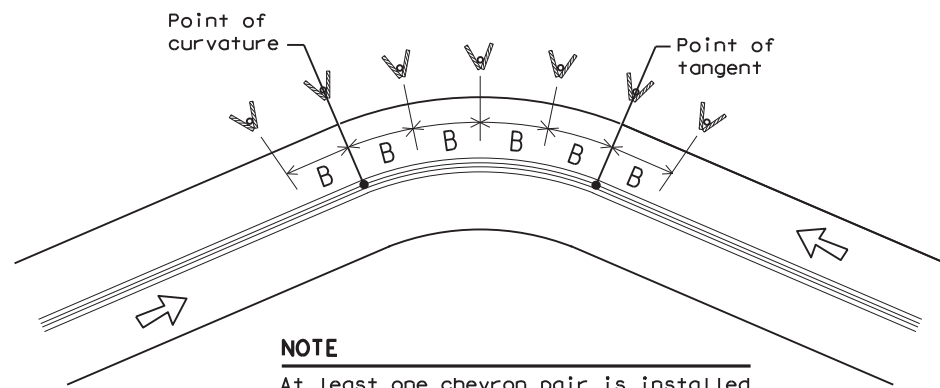

**NOTE**

At least one chevron pair is installed beyond the point of tangent in tangent section.

### DELINEATOR AND CHEVRON SPACING

WHEN DEGREE OF CURVE OR RADIUS IS KNOWN				
Degree of Curve	FEET			
	Radius of Curve	Spacing in Curve	Spacing in Straightaway	Chevron Spacing in Curve
		A	2A	B
1	5730	225	450	—
2	2865	160	320	—
3	1910	130	260	200
4	1433	110	220	160
5	1146	100	200	160
6	955	90	180	160
7	819	85	170	160
8	716	75	150	160
9	637	75	150	120
10	573	70	140	120
11	521	65	130	120
12	478	60	120	120
13	441	60	120	120
14	409	55	110	80
15	382	55	110	80
16	358	55	110	80
19	302	50	100	80
23	249	40	80	80
29	198	35	70	40
38	151	30	60	40
57	101	20	40	40

Curve delineator approach and departure spacing should include 3 delineators spaced at 2A. This spacing should be used during design preparation or when the degree of curve is known.

### DELINEATOR AND CHEVRON SPACING

WHEN DEGREE OF CURVE OR RADIUS IS NOT KNOWN			
Advisory Speed (MPH)	Spacing in Curve	Spacing in Straightaway	Chevron Spacing in Curve
	A	2xA	B
65	130	260	200
60	110	220	160
55	100	200	160
50	85	170	160
45	75	150	120
40	70	140	120
35	60	120	120
30	55	110	80
25	50	100	80
20	40	80	80
15	35	70	40

If the degree of curve is not known, delineator spacing may be determined based on the Advisory Speed of the curve. Use the delineator curve spacing for each Advisory Speed (MPH).

### DELINEATOR AND OBJECT MARKER APPLICATION AND SPACING

CONDITION	REQUIRED TREATMENT	MINIMUM SPACING
Frwy./Exp. Tangent	RPMs	See PM-series and FPM-series standard sheets
Frwy./Exp. Curve	Single delineators on right side	See delineator spacing table
Frwy/Exp. Ramp	Single delineators on at least one side of ramp (should be on outside of curves) (see Detail 3 on D&OM(4))	100 feet on ramp tangents Use delineator spacing table for ramp curves ("straightway spacing" does not apply to ramp curves)
Acceleration/Deceleration Lane	Double delineators (see Detail 3 on D&OM(4))	100 feet (See Detail 3 on D & OM (4))
Truck Escape Ramp	Single red delineators on both sides	50 feet
Bridge Rail (steel or concrete) and Metal Beam Guard Fence	Bi-Directional Delineators when undivided with one lane each direction Single Delineators when multiple lanes each direction	Equal spacing (100' max) but not less than 3 delineators
Concrete Traffic Barrier (CTB) or Steel Traffic Barrier	Barrier reflectors matching the color of the edge line	Equal spacing 100' max
Cable Barrier	Reflectors matching the color of the edge line	Every 5th cable barrier post (up to 100' max)
Guard Rail Terminus/Impact Head	Divided highway - Object marker on approach end Undivided 2-lane highways - Object marker on approach and departure end	Requires reflective sheeting provided by manufacturer per D & OM (VIA) or a Type 3 Object Marker (OM-3) in front of the terminal end See D & OM (5) and D & OM (6)
Bridges with no Approach Rail	Type 3 Object Marker (OM-3) at end of rail and 3 single delineators approaching rail	See D & OM(5)
Reduced Width Approaches to Bridge Rail	Type 2 and Type 3 Object Markers (OM-3) and 3 single delineators approaching bridge	Requires reflective sheeting provided by manufacturer per D & OM (VIA) or a Type 3 Object Marker (OM-3) in front of the terminal end See D & OM (5)
Culverts without MBGF	Type 2 Object Markers	See Detail 2 on D & OM(4)
Crossovers	Double yellow delineators and RPMs	See Detail 1 on D & OM (4)
Pavement Narrowing (lane merge) on Freeways/Expressway	Single delineators adjacent to affected lane for full length of transition	100 feet

**NOTES**

- Unless indicated otherwise, the delineator or barrier reflector color shall conform to the color of the pavement edge line on the side of the road where the delineators or barrier reflectors are placed.
- Barrier reflectors may be used to replace required delineators.
- Single red delineators may be mounted on the back side of delineator posts for wrong way driver applications

**LEGEND**

	Bi-directional Delineator
	Delineator
	Sign



## DELINEATOR & OBJECT MARKER PLACEMENT DETAILS

### D & OM(3)-20

FILE: dom3-20.dgn	DW: TXDOT	CK: TXDOT	DW: TXDOT	CK: TXDOT
© TXDOT August 2004	CONT	SECT	JOB	HIGHWAY
REVISIONS	6435	38	001	IH10, etc
3-15 8-15	DIST	COUNTY	SHEET NO.	
8-15 7-20	BMT	JEFFERSON, etc	76	

DISCLAIMER: The use of this standard is governed by the "Texas Engineering Practice Act". No warranty of any kind is made by TxDOT for any purpose whatsoever. TxDOT assumes no responsibility for the conversion of this standard to other formats or for incorrect results or damages resulting from its use.

DATE: FILE:

DISCLAIMER: The use of this standard is governed by the "Texas Engineering Practice Act". No warranty of any kind is made by TxDOT for any purpose whatsoever. TxDOT assumes no responsibility for the conversion of this standard to other formats or for incorrect results or damages resulting from its use.

**CROSSOVERS**

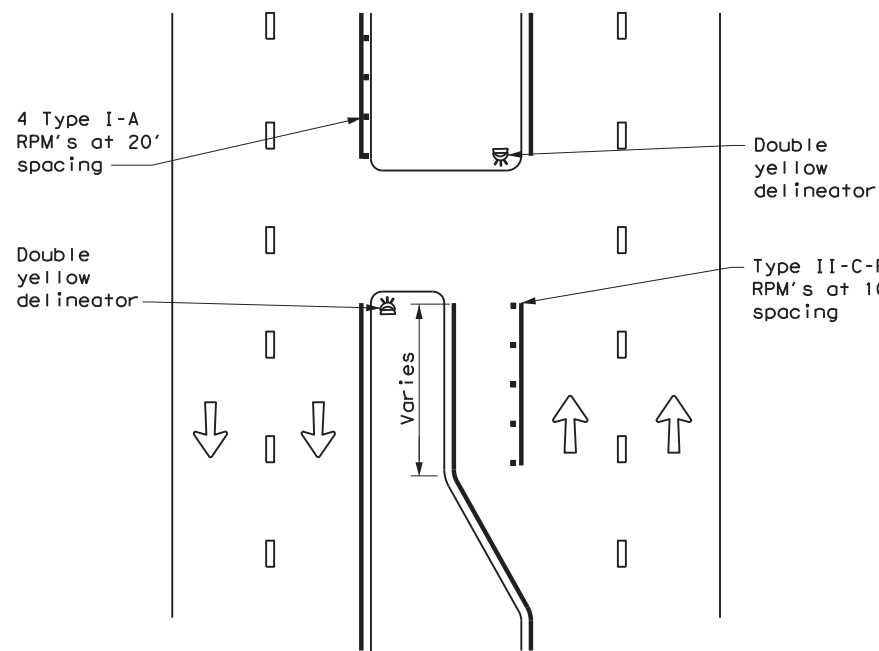

**DETAIL 1**

**FOR CULVERTS WITHOUT MBGF**

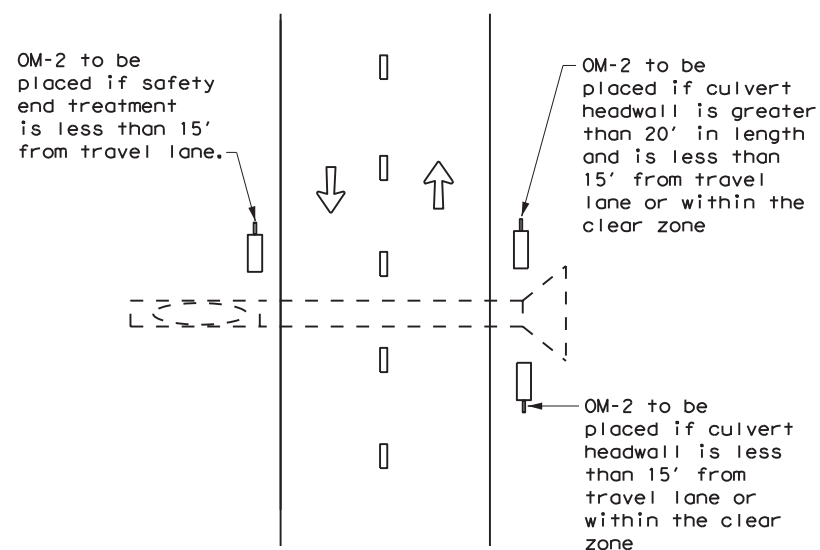

**DETAIL 2**

**FREEWAY DELINEATION FOR RAMPS AND ACCELERATION/DECELERATION LANES**

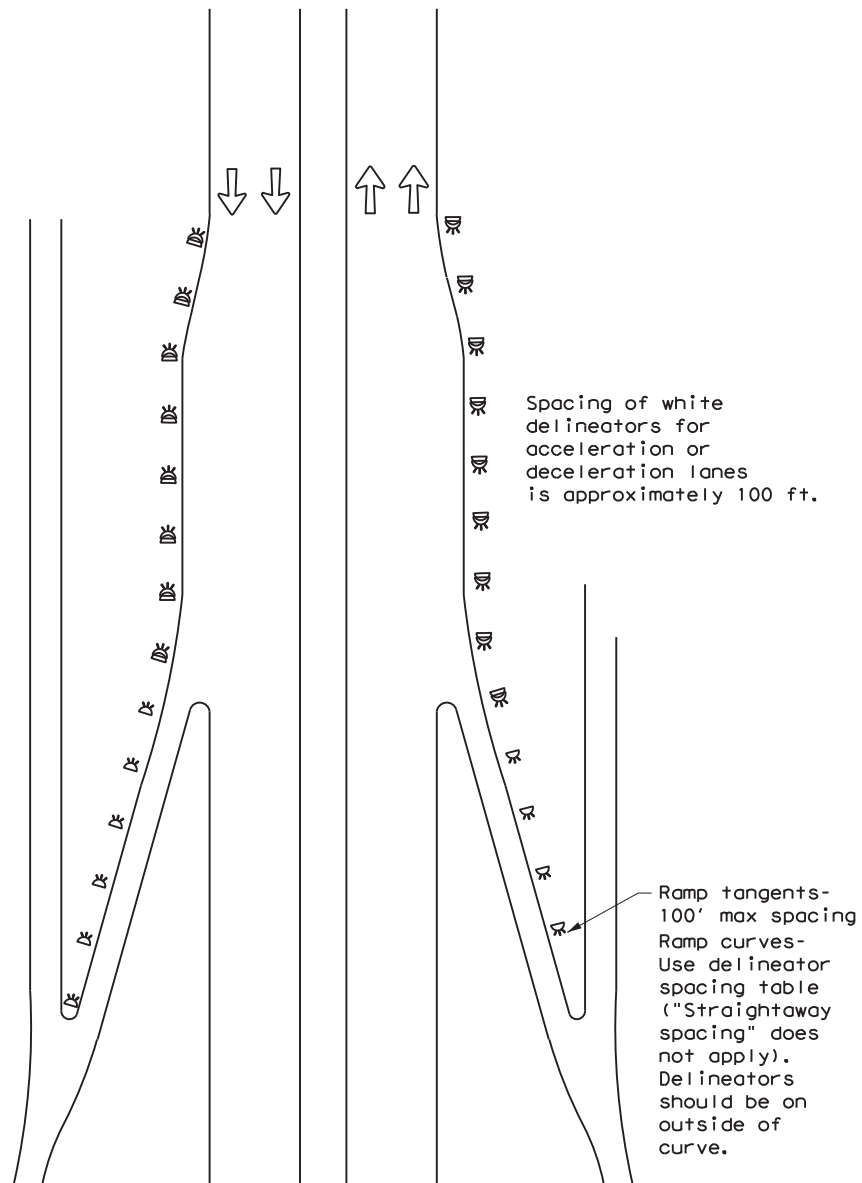

**DETAIL 3**

**TYPICAL APPLICATION OF DEAD END BARRICADE**

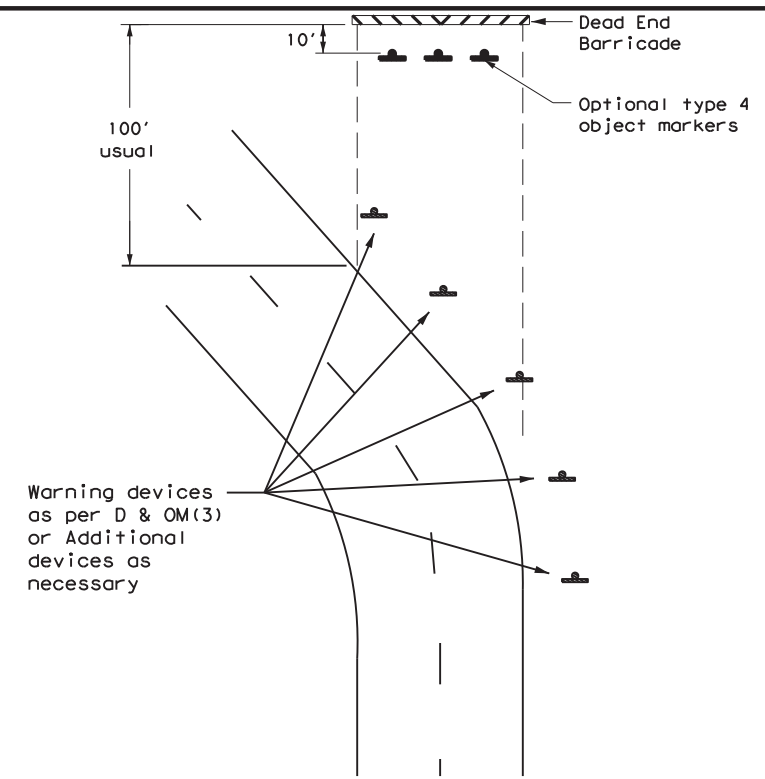

**DETAIL 4**

**TYPICAL DEAD END BARRICADE INSTALLATION**

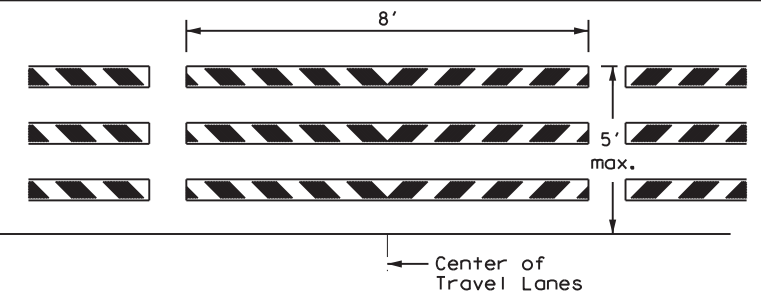

**NOTES**

1. Barricade striping shall be red and white reflective sheeting for all permanent road closures.
2. Barricade striping is red and white sloping toward the center of the roadway.
3. Type 3 Barricade Supports should be anchored to soil or pavement as described in compliant Work Zone Traffic Control Devices List, section D.2.f and D.2.g.

**DETAIL 5**

LEGEND	
	Bidirectional Delineator
	Delineator
	OM-3
	Barricade
	Sign
	OM-2
	Double Delineator



**DELINEATOR & OBJECT MARKER PLACEMENT DETAILS**

**D & OM(4) -20**

FILE: dom4-20.dgn	DN: TXDOT	CK: TXDOT	OW: TXDOT	CR: TXDOT
© TXDOT August 2004	CONT	SECT	JOB	HIGHWAY
REVISIONS	6435	38	001	IH10, etc
3-15	DIST	COUNTY	SHEET NO.	
7-20	BMT	JEFFERSON, etc	77	

DATE:  
FILE:

**TWO-WAY, TWO LANE ROADWAY WITH REDUCED WIDTH APPROACH RAIL**

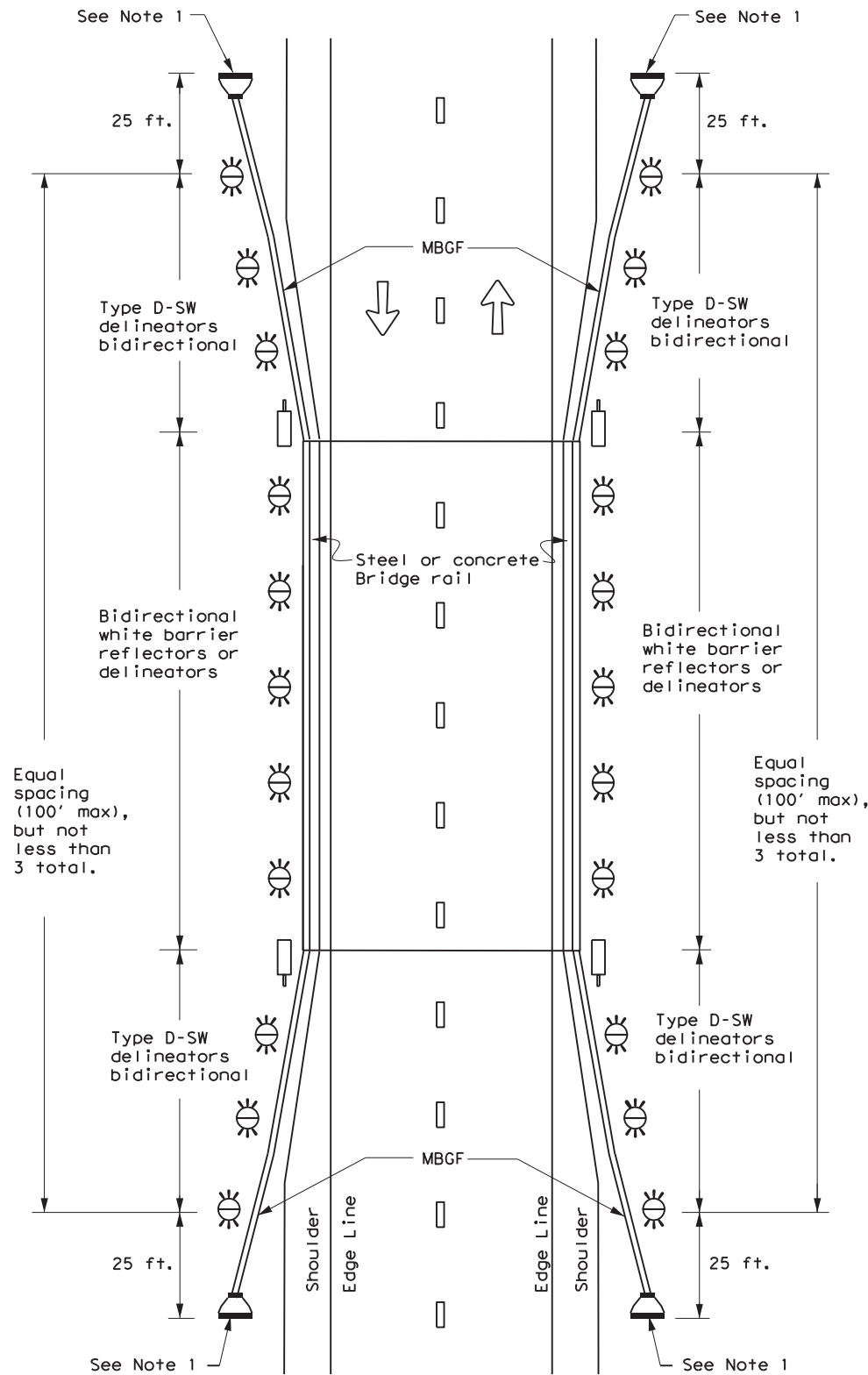

**NOTE:**

1. Terminal ends require reflective sheeting provided by manufacturer per D & OM (VIA) or a Type 3 Object Marker (OM-3) in front of the terminal end.

**TWO-WAY, TWO LANE ROADWAY WITH METAL BEAM GUARD FENCE (MBGF)**

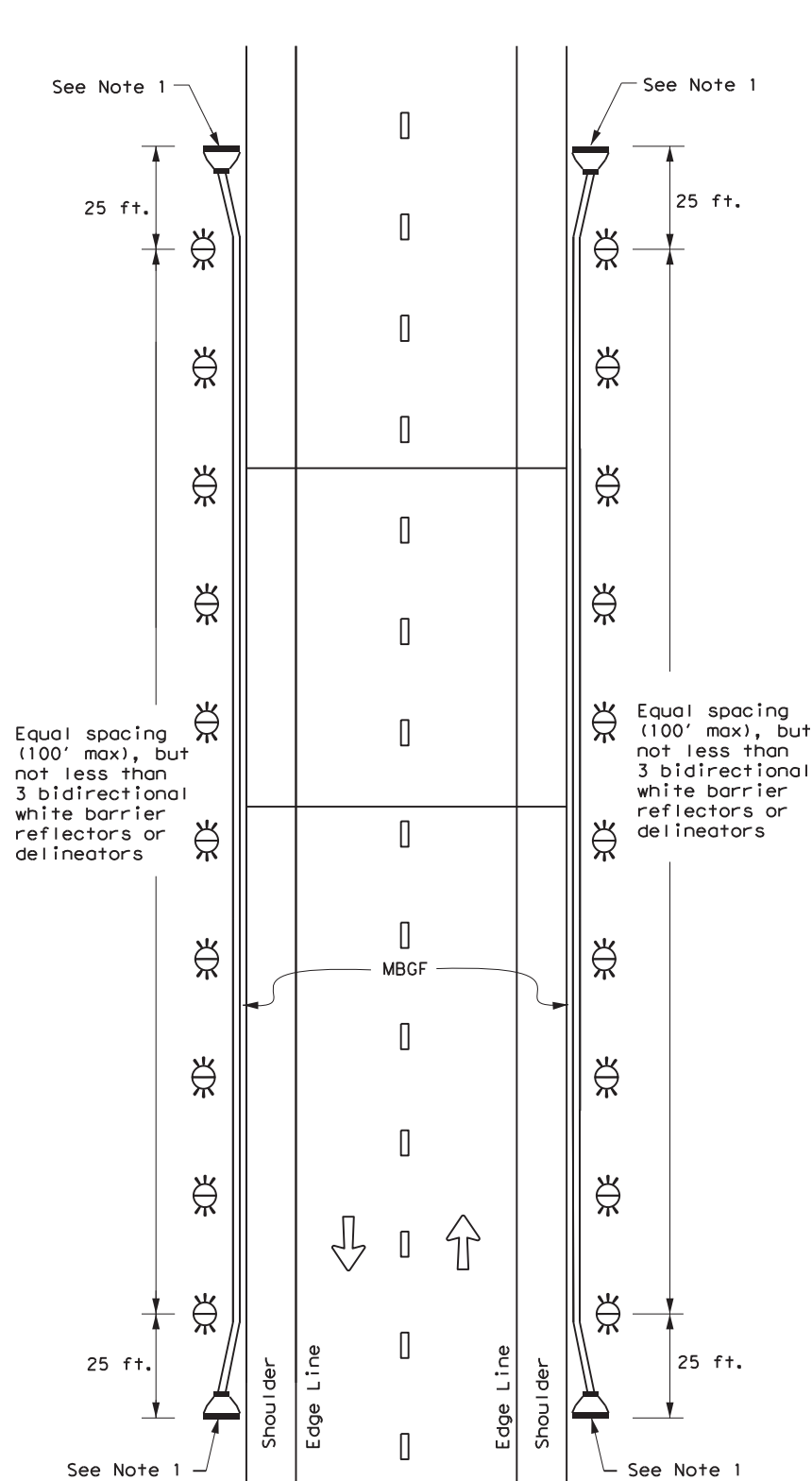

**NOTE:**

1. Terminal ends require reflective sheeting provided by manufacturer per D & OM (VIA) or a Type 3 Object Marker (OM-3) in front of the terminal end.

**TWO-WAY, TWO LANE ROADWAY BRIDGE WITH NO APPROACH RAIL**

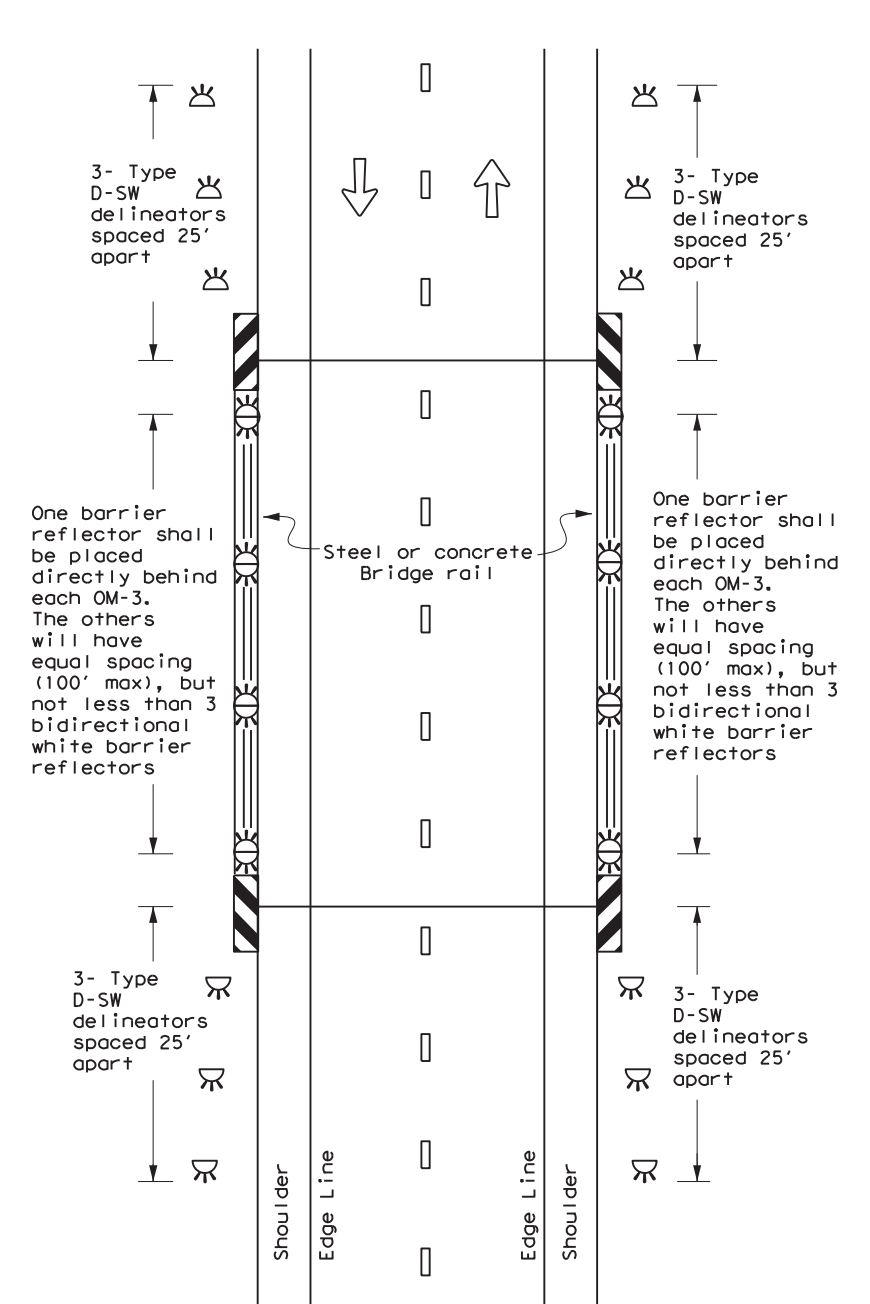

**LEGEND**

	Bidirectional Delineator
	Delineator
	OM-3
	OM-2
	Terminal End
	Traffic Flow



**DELINEATOR & OBJECT MARKER PLACEMENT DETAILS**

**D & OM(5)-20**

FILE: dom5-20.dgn	DN: TxDOT	CK: TxDOT	DW: TxDOT	CR: TxDOT
© TxDOT August 2015	CONT	SECT	JOB	HIGHWAY
REVISIONS	6435	38	001	IH10, etc
7-20	DIST	COUNTY	SHEET NO.	
	BMT	JEFFERSON, etc	78	

DISCLAIMER: The use of this standard is governed by the "Texas Engineering Practice Act". No warranty of any kind is made by TxDOT for any purpose whatsoever. TxDOT assumes no responsibility for the conversion of this standard to other formats or for incorrect results or damages resulting from its use.

DATE: FILE:

DISCLAIMER: The use of this standard is governed by the "Texas Engineering Practice Act". No warranty of any kind is made by TxDOT for any purpose whatsoever. TxDOT assumes no responsibility for the conversion of this standard to other formats or for incorrect results or damages resulting from its use.

**CONTINUOUS CONCRETE OR STEEL BARRIER**

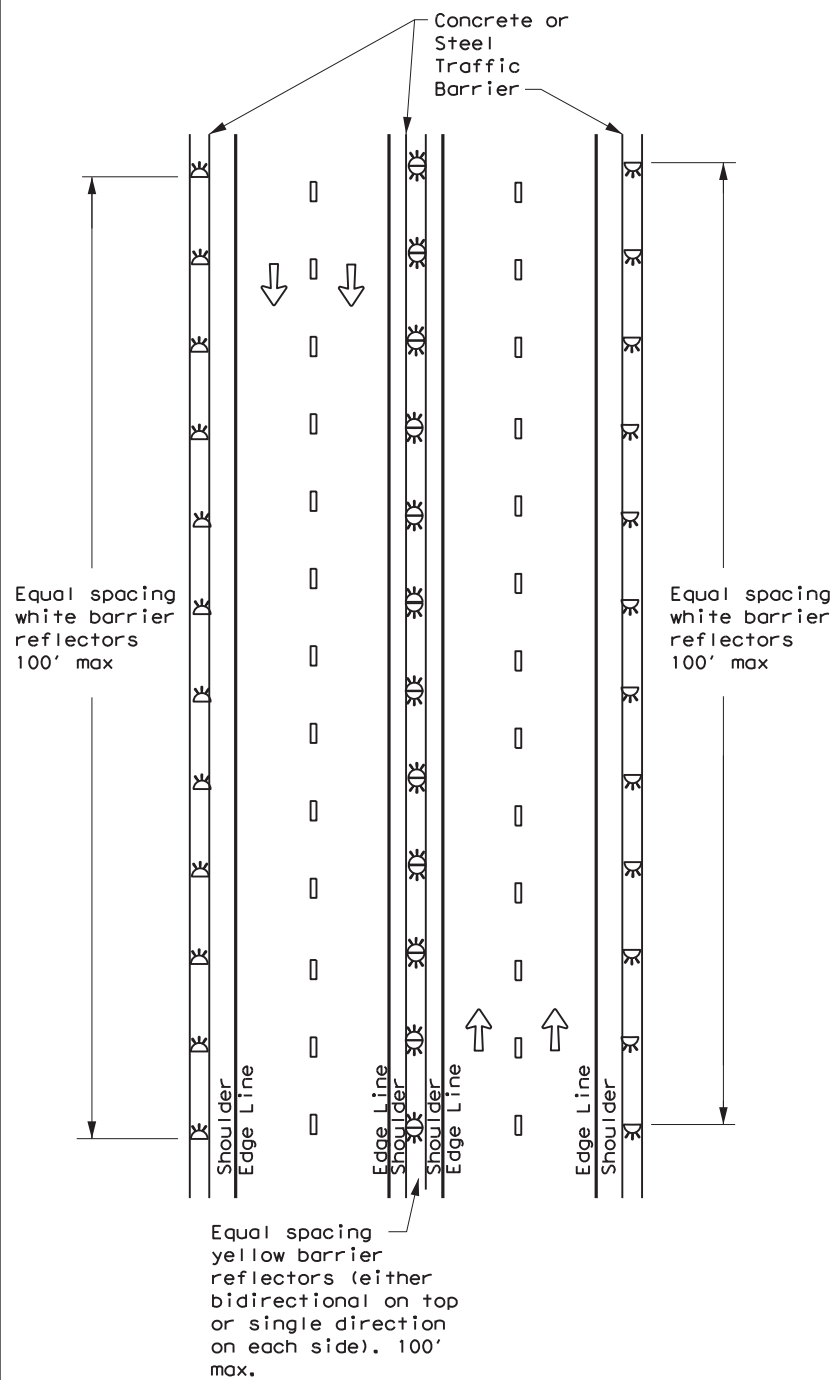

**MULTI-LANE UNDIVIDED, TWO-WAY ROADWAY WITH METAL BEAM GUARD FENCE (MBGF)**

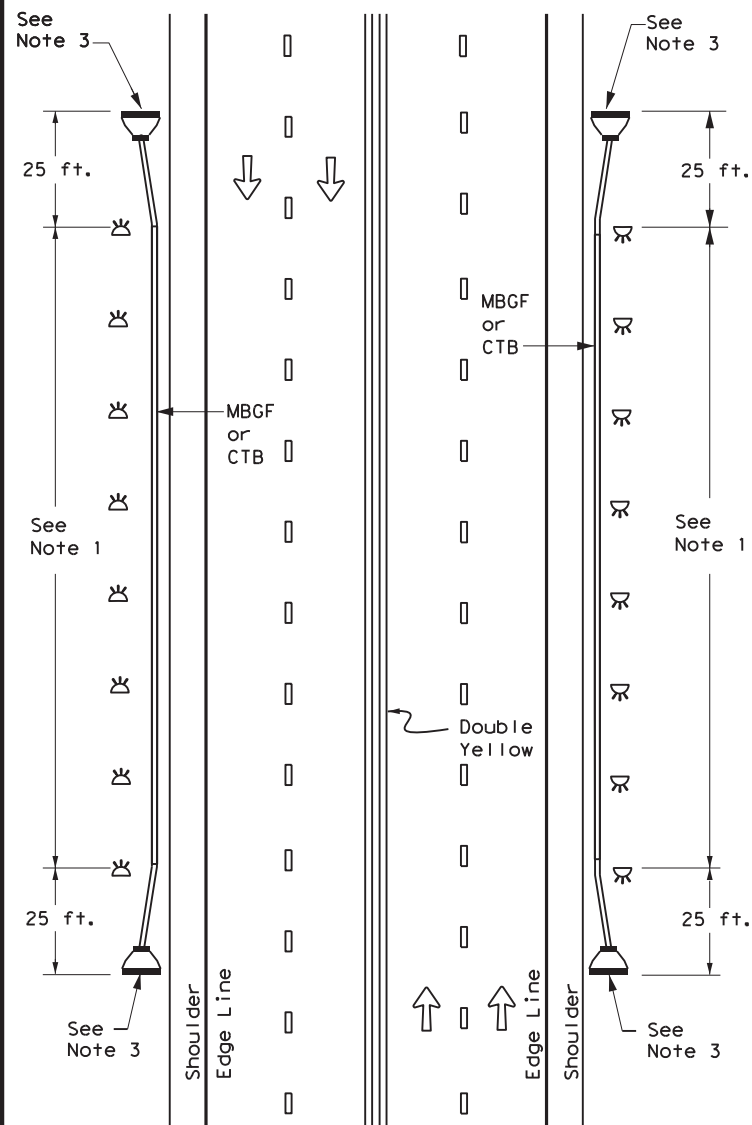

**DIVIDED ROADWAY WITH METAL BEAM GUARD FENCE (MBGF)**

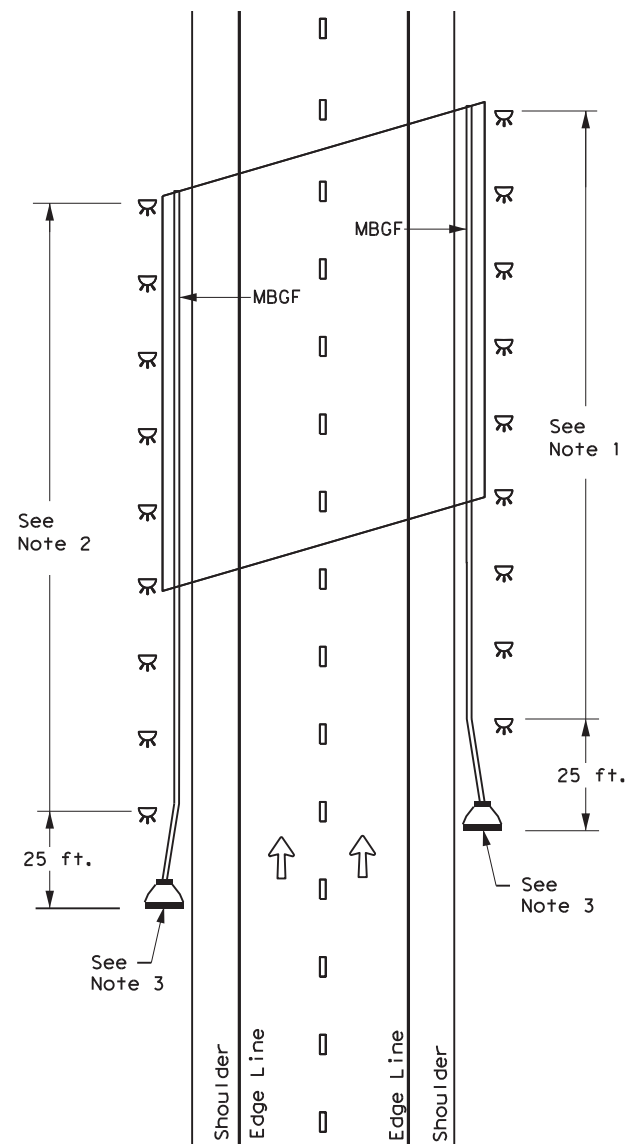

**EMERGENCY CROSSOVER**

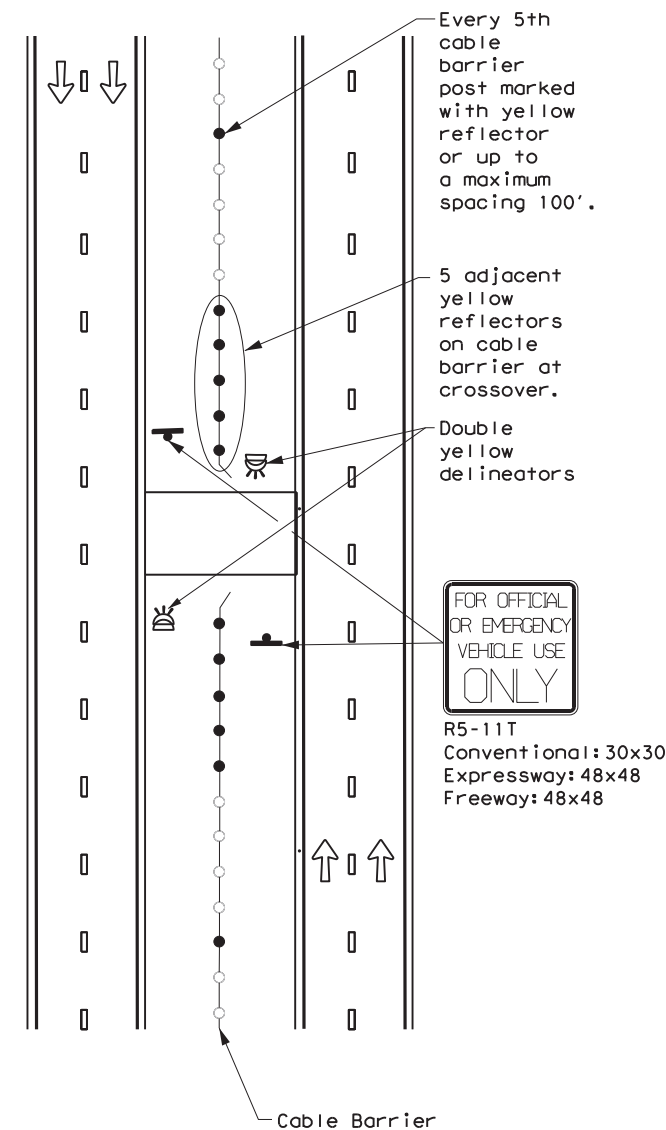

**NOTES**

1. Equal spacing (100' max), but not less than 3 single directional white barrier reflectors or delineators. On Continuous Barrier, equal spacing (100' max.)
2. Equal spacing (100' max), but not less than 3 single directional yellow barrier reflectors or delineators.
3. Terminal ends require reflective sheeting provided by manufacturer per D & OM (VIA) or a Type 3 Object Marker (OM-3) in front of the terminal end.

**LEGEND**

	Bidirectional Delineator
	Delineator
	OM-3
	OM-2
	Terminal End
	Traffic Flow



**DELINEATOR & OBJECT MARKER PLACEMENT DETAILS**

**D & OM(6)-20**

FILE: dom6-20.dgn	DN: TxDOT	CK: TxDOT	DW: TxDOT	CR: TxDOT
© TxDOT August 2015	CONT	SECT	JOB	HIGHWAY
REVISIONS	6435	38	001	IH10, etc
7-20	DIST	COUNTY	SHEET NO.	
	BMT	JEFFERSON, etc	79	

DATE:  
FILE:

DISCLAIMER: The use of this standard is governed by the "Texas Engineering Practice Act". No warranty of any kind is made by TxDOT for any purpose whatsoever. TxDOT assumes no responsibility for the conversion of this standard to other formats or for incorrect results or damages resulting from its use.

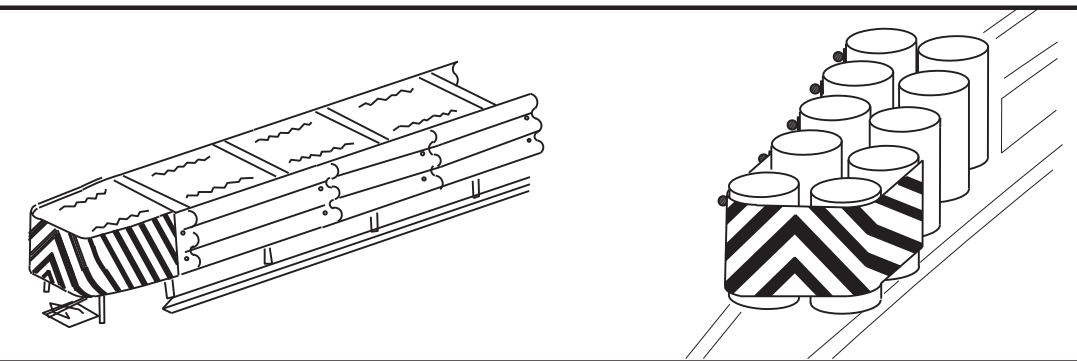
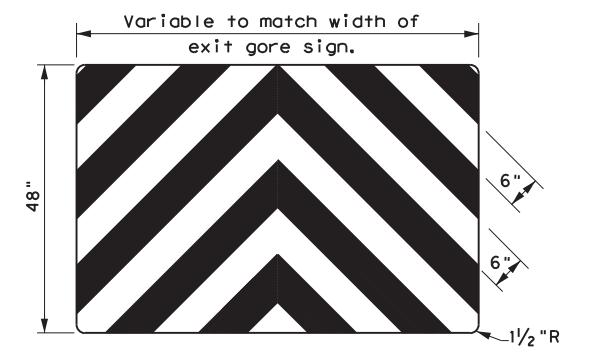
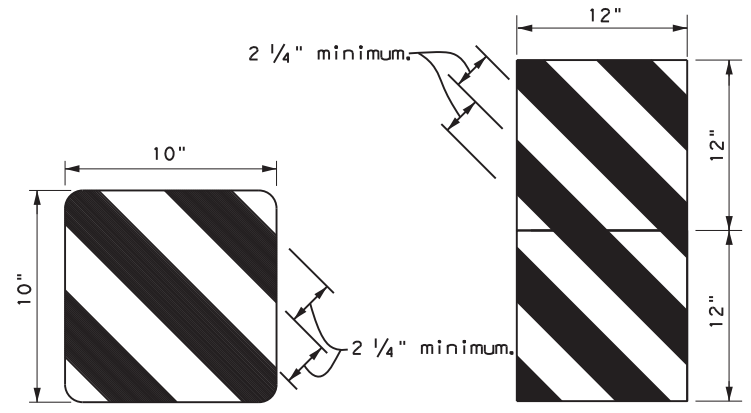
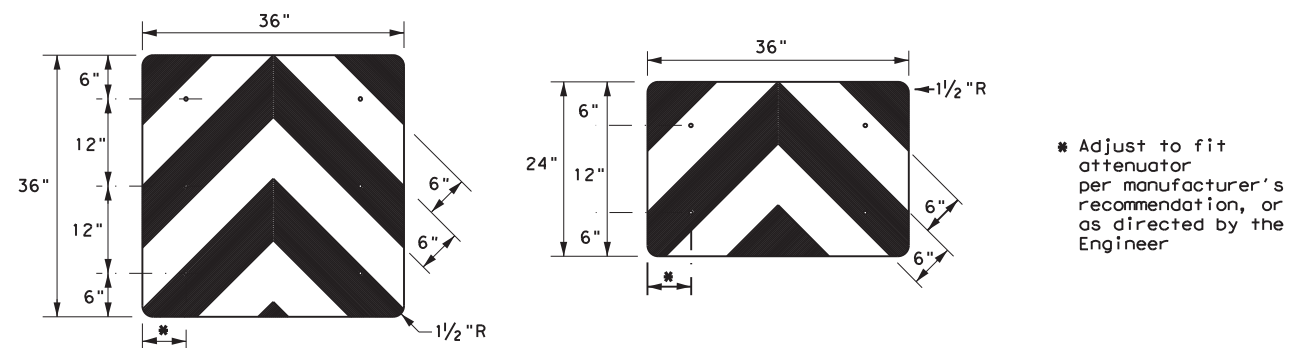
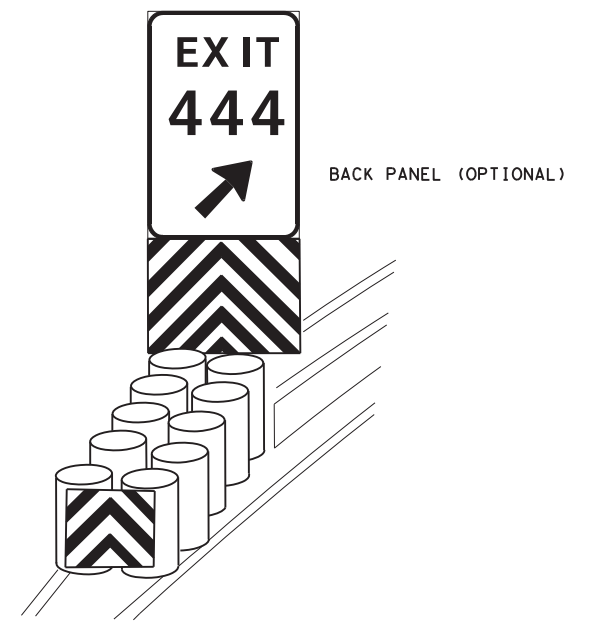
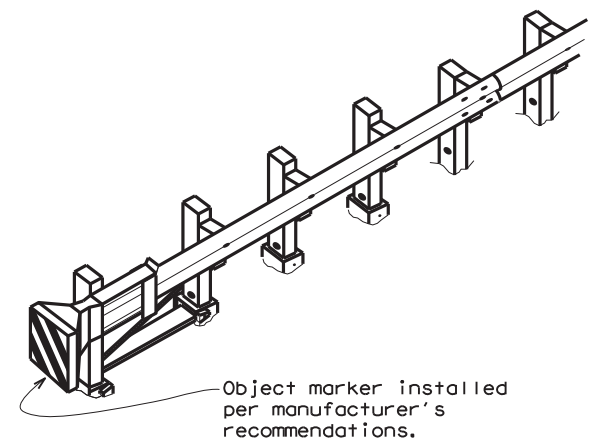
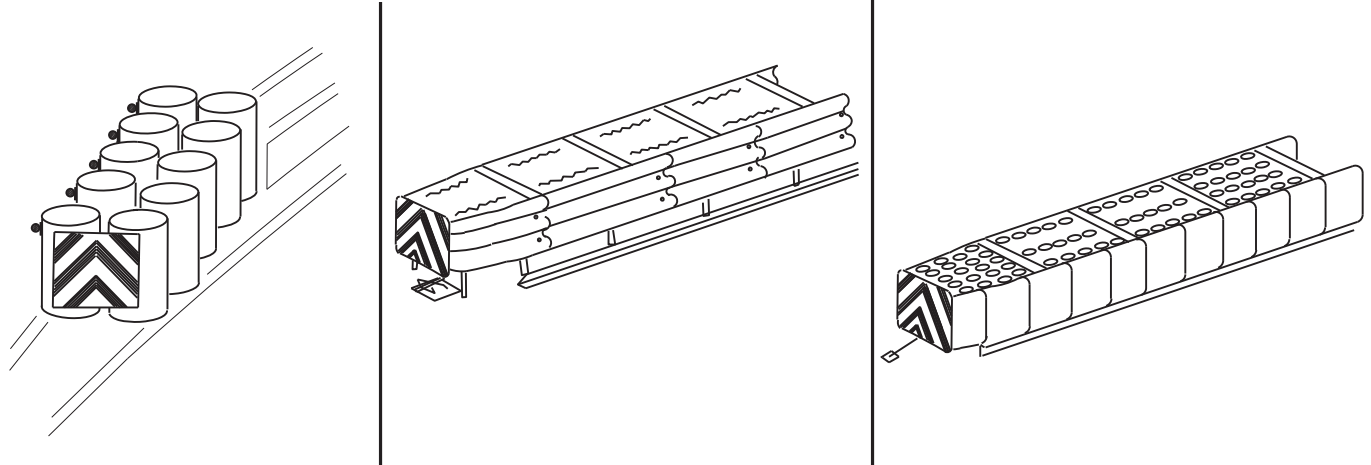

OBJECT MARKERS SMALLER THAN 3 FT<sup>2</sup>

**NOTES**

- Object Markers shall conform to the Texas MUTCD and meet the color and reflectivity requirement of Department Material Specification DMS 8300. Background shall be yellow reflective sheeting (Type B or C) and Chevron shall be black.
- Object Markers may be fabricated from adhesive backed reflective sheeting applied directly to guardrail end treatment, or applied directly to an "end cap" as per the manufacturer's recommendation. Direct applied sheeting shall provide a smooth surface and have no wrinkles, air bubbles, cuts or tears. A radius at the corners is not required for direct applied sheeting.
- Object Marker size may be reduced to fit smaller devices. Width of alternating black and yellow stripes are typically 6". Object Markers smaller than 3ft may have reduced width stripes of a minimum of 2 1/4".
- Pop rivets, screws, or nuts and bolts may be used to attach object markers and reflectors. Holes, slots or other openings may be cut or drilled through object markers to allow cable or other attachments.
- Object Marker at nose of attenuator is subsidiary to the attenuator.
- See D & OM (1-4) for required barrier reflectors.

**NOTES**

- Spacing should be adjusted to attach through centerline of drum, per attenuator manufacturer's recommendation, or as directed by the Engineer.
- Mounting should be flush with top of attenuator. Minimum size 96" x 24".

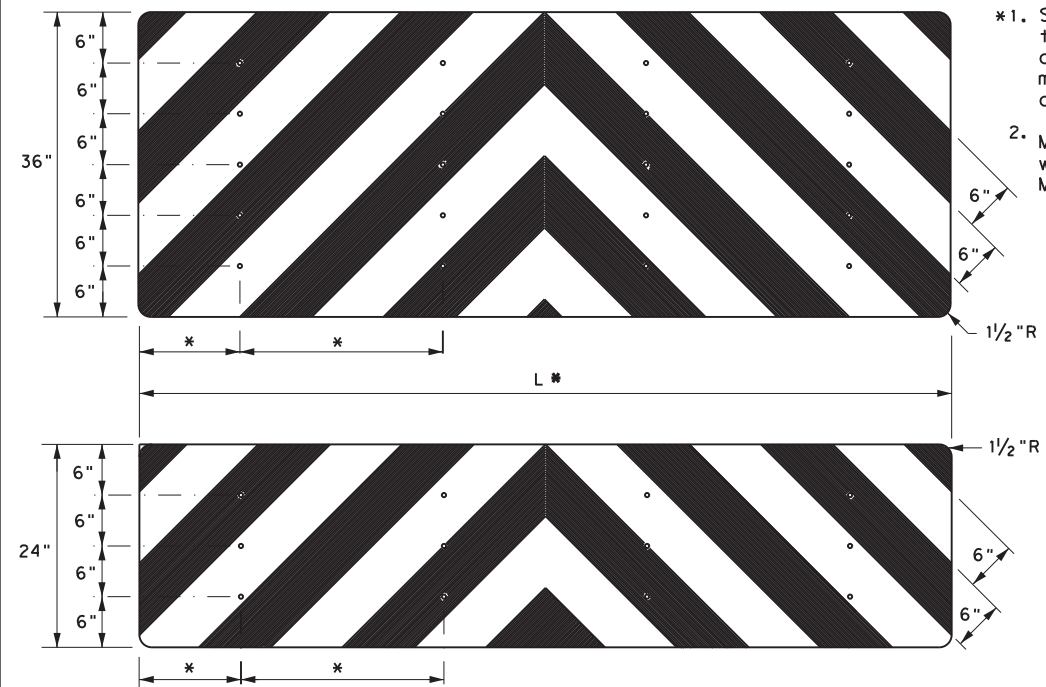

DATE:  
FILE:

		Traffic Safety Division Standard	
<b>DELINEATOR &amp; OBJECT MARKER FOR VEHICLE IMPACT ATTENUATORS</b> <b>D &amp; OM(VIA) -20</b>			
FILE: domvia20.dgn	DN: TXDOT	CK: TXDOT	DW: TXDOT
© TXDOT December 1989	CONT	SECT	JOB
REVISIONS		6435 38	001 IH10, etc
4-92 8-04	DIST	COUNTY	SHEET NO.
8-95 3-15	BMT	JEFFERSON, etc	80
4-98 7-20			
20G			



DISCLAIMER: The use of this standard is governed by the "Texas Engineering Practice Act". No warranty of any kind is made by TxDOT for any purpose whatsoever. TxDOT assumes no responsibility for the conversion of this standard to other formats or for incorrect results or damages resulting from its use.

DATE: FILE:

**I. STORMWATER POLLUTION PREVENTION-CLEAN WATER ACT SECTION 402**

TPDES TXR 150000: Stormwater Discharge Permit or Construction General Permit required for projects with 1 or more acres disturbed soil. Projects with any disturbed soil must protect for erosion and sedimentation in accordance with Item 506.

List MS4 Operator(s) that may receive discharges from this project. They may need to be notified prior to construction activities.

1. TxDOT - Beaumont District

2.  No Action Required  Required Action

Action No.

- Prevent stormwater pollution by controlling erosion and sedimentation in accordance with TPDES Permit TXR 150000
- Comply with the SW3P and revise when necessary to control pollution or required by the Engineer.
- Post Construction Site Notice (CSN) with SW3P information on or near the site, accessible to the public and TCEQ, EPA or other inspectors.
- When Contractor project specific locations (PSL's) increase disturbed soil area to 5 acres or more, submit NOI to TCEQ and the Engineer.

**II. WORK IN OR NEAR STREAMS, WATERBODIES AND WETLANDS CLEAN WATER ACT SECTIONS 401 AND 404**

USACE Permit required for filling, dredging, excavating or other work in any water bodies, rivers, creeks, streams, wetlands or wet areas.

The Contractor must adhere to all of the terms and conditions, including Regional conditions for the State of Texas, associated with the following permit(s):

- No Permit Required
- Nationwide Permit 14 - PCN not Required (less than 1/10th acre waters or wetlands affected)
- Nationwide Permit 14 - PCN Required (1/10 to <1/2 acre, 1/3 in tidal waters)
- Individual 404 Permit Required: Permit # \_\_\_\_\_
- Other Nationwide Permit Required: NWP# \_\_\_\_\_

Required Actions: List waters of the US permit applies to, location in project and check Best Management Practices planned to control erosion, sedimentation and post-project TSS.

- Maintain a neat and clean worksite next to the water and do not allow any debris to fall into the water.
- 
- 
- 

The elevation of the ordinary high water marks of any areas requiring work to be performed in the waters of the US requiring the use of a nationwide permit can be found on the Bridge Layouts.

Best Management Practices:

<b>Erosion</b>	<b>Sedimentation</b>	<b>Post-Construction TSS</b>
<input type="checkbox"/> Temporary Vegetation	<input checked="" type="checkbox"/> Silt Fence	<input checked="" type="checkbox"/> Vegetative Filter Strips
<input type="checkbox"/> Blankets/Matting	<input type="checkbox"/> Rock Berm	<input type="checkbox"/> Retention/Irrigation Systems
<input type="checkbox"/> Mulch	<input type="checkbox"/> Triangular Filter Dike	<input type="checkbox"/> Extended Detention Basin
<input type="checkbox"/> Sodding	<input type="checkbox"/> Sand Bag Berm	<input type="checkbox"/> Constructed Wetlands
<input type="checkbox"/> Interceptor Swale	<input type="checkbox"/> Straw Bale Dike	<input type="checkbox"/> Wet Basin
<input type="checkbox"/> Diversion Dike	<input type="checkbox"/> Brush Berms	<input type="checkbox"/> Erosion Control Compost
<input type="checkbox"/> Erosion Control Compost	<input type="checkbox"/> Erosion Control Compost	<input type="checkbox"/> Mulch Filter Berm and Socks
<input type="checkbox"/> Mulch Filter Berm and Socks	<input type="checkbox"/> Mulch Filter Berm and Socks	<input type="checkbox"/> Compost Filter Berm and Socks
<input type="checkbox"/> Compost Filter Berm and Socks	<input type="checkbox"/> Compost Filter Berm and Socks	<input type="checkbox"/> Vegetation Lined Ditches
	<input type="checkbox"/> Stone Outlet Sediment Traps	<input type="checkbox"/> Sand Filter Systems
	<input type="checkbox"/> Sediment Basins	

**III. CULTURAL RESOURCES**

Refer to TxDOT Standard Specifications in the event historical issues or archeological artifacts are found during construction. Upon discovery of archeological artifacts (bones, burnt rock, flint, pottery, etc.) cease work in the immediate area and contact the Engineer immediately.

No Action Required  Required Action

Action No.

- 
- 
- 
- 

**IV. VEGETATION RESOURCES**

Preserve native vegetation to the extent practical. Contractor must adhere to Construction Specification Requirements Specs 162, 164, 192, 193, 506, 730, 751, 752 in order to comply with requirements for invasive species, beneficial landscaping, and tree/brush removal commitments.

No Action Required  Required Action

Action No.

- 
- 
- 
- 

**V. FEDERAL LISTED, PROPOSED THREATENED, ENDANGERED SPECIES, CRITICAL HABITAT, STATE LISTED SPECIES, CANDIDATE SPECIES AND MIGRATORY BIRDS.**

No Action Required  Required Action

Action No.

- 
- 
- 
- 

If any of the listed species are observed, cease work in the immediate area, do not disturb species or habitat and contact the Engineer immediately. The work may not remove active nests from bridges and other structures during nesting season of the birds associated with the nests. If caves or sinkholes are discovered, cease work in the immediate area, and contact the Engineer immediately.

**LIST OF ABBREVIATIONS**

BMP: Best Management Practice	SPCC: Spill Prevention Control and Countermeasure
CGP: Construction General Permit	SW3P: Storm Water Pollution Prevention Plan
DSHS: Texas Department of State Health Services	PCN: Pre-Construction Notification
FHWA: Federal Highway Administration	PSL: Project Specific Location
MOA: Memorandum of Agreement	TCEQ: Texas Commission on Environmental Quality
MOU: Memorandum of Understanding	TPDES: Texas Pollutant Discharge Elimination System
MS4: Municipal Separate Stormwater Sewer System	TPWD: Texas Parks and Wildlife Department
MBTA: Migratory Bird Treaty Act	TxDOT: Texas Department of Transportation
NOT: Notice of Termination	T&E: Threatened and Endangered Species
NWP: Nationwide Permit	USACE: U.S. Army Corps of Engineers
NOI: Notice of Intent	USFWS: U.S. Fish and Wildlife Service

**VI. HAZARDOUS MATERIALS OR CONTAMINATION ISSUES**

General (applies to all projects):

Comply with the Hazard Communication Act (the Act) for personnel who will be working with hazardous materials by conducting safety meetings prior to beginning construction and making workers aware of potential hazards in the workplace. Ensure that all workers are provided with personal protective equipment appropriate for any hazardous materials used. Obtain and keep on-site Material Safety Data Sheets (MSDS) for all hazardous products used on the project, which may include, but are not limited to the following categories: Paints, acids, solvents, asphalt products, chemical additives, fuels and concrete curing compounds or additives. Provide protected storage, off bare ground and covered, for products which may be hazardous. Maintain product labelling as required by the Act. Maintain an adequate supply of on-site spill response materials, as indicated in the MSDS. In the event of a spill, take actions to mitigate the spill as indicated in the MSDS, in accordance with safe work practices, and contact the District Spill Coordinator immediately. The Contractor shall be responsible for the proper containment and cleanup of all product spills.

Contact the Engineer if any of the following are detected:

- \* Dead or distressed vegetation (not identified as normal)
- \* Trash piles, drums, canister, barrels, etc.
- \* Undesirable smells or odors
- \* Evidence of leaching or seepage of substances

List below any bridge class structure(s), not including box culverts, being replaced, rehabilitated, removed, extended or modified as part of this project, or state "None", if applicable.

If "None", then no further action is required. Otherwise TxDOT is responsible for completing asbestos assessment/inspection and evaluation for presence of lead. Provide results below:

Structure Location	PSN	Element	Lead	Asbestos

If Asbestos is present, then TxDOT must retain a DSHS licensed asbestos consultant to assist with the notification, develop abatement/mitigation procedures, and perform management activities as necessary. The notification form to DSHS must be postmarked at least 15 working days prior to scheduled demolition.

If Asbestos is not present, then TxDOT is still required to notify DSHS 15 working days prior to any scheduled demolition.

In either case, the Contractor is responsible for providing the date(s) for abatement activities and/or demolition with careful coordination between the Engineer and asbestos consultant in order to minimize construction delays and subsequent claims.

Any other evidence indicating possible hazardous materials or contamination discovered on site. Hazardous Materials or Contamination Issues Specific to this Project:

No Action Required  Required Action

Action No.

- 

**VII. OTHER ENVIRONMENTAL ISSUES**

(includes regional issues such as Edwards Aquifer District, etc.)

No Action Required  Required Action

Action No.

- 

			Beaumont District Standard		
<b>ENVIRONMENTAL PERMITS, ISSUES AND COMMITMENTS</b> <b>EPIC</b>					
FILE:	epic.dgn	DN: TxDOT	CK: AM	DW: VP	CK: AR
© TxDOT	January 2012	CONT	SECT	JOB	HIGHWAY
REVISIONS 12-12-2011 (DS) 05-07-14 ADDED CONTRACTOR NOTE TO SECTION IV.		6435	38	001	IH10, etc
		DIST	COUNTY		SHEET NO.
		BMT	JEFFERSON, etc		81