

STATE OF TEXAS DEPARTMENT OF TRANSPORTATION

PLANS OF PROPOSED HIGHWAY ROUTINE MAINTENANCE CONTRACT CALLOUT REFLECTORIZED PAVEMENT MARKINGS AND MARKERS RMC 6379-54-001 VARIOUS ROADWAYS IN JOHNSON COUNTY

REQUIRED SIGNS SHALL BE IN ACCORDANCE WITH BC (11)- 14 THRU BC (12)- 14 AND THE "TEXAS MANUAL ON UNIFORM TRAFFIC CONTROL DEVICES".

STATE PROJECT NO.			
RMC 6379-54-001			
CONT	SECT	JOB	HIGHWAY
6379	54	001	SH 174, ETC
DIST	COUNTY		SHEET NO.
02	JOHNSON		1

FINAL PLANS

LETTING DATE: _____

DATE CONTRACTOR BEGAN WORK: _____

DATE WORK WAS COMPLETED & ACCEPTED: _____

FINAL CONTRACT COST: \$ _____

CONTRACTOR : _____

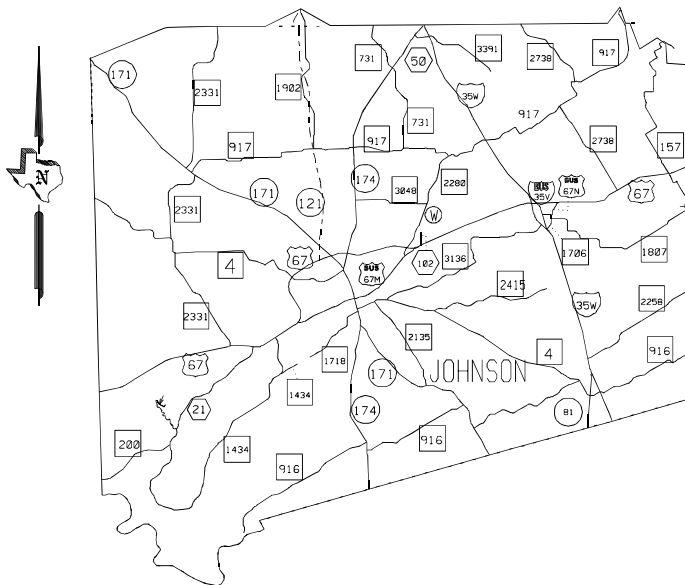

SPECIFICATIONS ADOPTED BY THE TEXAS DEPARTMENT OF TRANSPORTATION, NOVEMBER 1, 2014 AND SPECIFICATION ITEMS LISTED AND DATED AS FOLLOWS, SHALL GOVERN ON THIS PROJECT.

EXCEPTIONS: NONE
EQUATIONS: NONE
RAILROAD CROSSINGS: NONE

©2021 By Texas Department of Transportation
all rights reserved



SUBMITTED FOR LETTING: 4/28/2021

Designed by:
Janet Crawford
AREA ENGINEER

RECOMMENDED FOR LETTING: 4/28/2021

Designed by:
Matthew L. Evans, P.E.
DIRECTOR OF MAINTENANCE

RECOMMENDED FOR LETTING: 4/28/2021

Designed by:
Carl L. Johnson, P.E.
DISTRICT ENGINEER

GENERAL

SHEET NO.	DESCRIPTION
1	TITLE SHEET
2	INDEX SHEET
3A-3I	GENERAL NOTES
4	ESTIMATE AND QUANTITIES
5	PROJECT LIMITS
6	PROJECT LOCATION MAP

STRIPING DETAILS

SHEET NO.	DESCRIPTION
7	PM(1)-20*
8	PM(2)-20*
9	PM(3)-20*
10	PM(4)-20*
11	FPM(1)-12*
12	FPM(2)-12*
13	FPM(3)-12*
14	FPM(4)-12*
15	RCD(1)-16*
16	RCD(2)-16*

TCP STANDARDS

SHEET NO.	DESCRIPTION
17	TCP(1-1)-18*
18	TCP(1-2)-18*
19	TCP(1-3)-18*
20	TCP(1-4)-18*
21	TCP(1-5)-18*
22	TCP(2-2)-18*
23	TCP(2-3)-18*
24	TCP(2-4)-18*
25	TCP(2-6)-18*

TCP STANDARDS (CONT.)

SHEET NO.	DESCRIPTION
26	TCP(3-1)-13*
27	TCP(3-2)-13*
28	TCP(3-3)-14*
29	TCP(6-1)-12*
30	TCP(6-2)-12*
31	TCP(6-3)-12*
32	TCP(6-4)-12*

BC STANDARDS

SHEET NO.	DESCRIPTION
33	BC(1)-14*
34	BC(2)-14*
35	BC(3)-14*
36	BC(4)-14*
37	BC(5)-14*
38	BC(6)-14*
39	BC(7)-14*
40	BC(8)-14*
41	BC(9)-14*
42	BC(10)-14*
43	BC(11)-14*
44	BC(12)-14*

WORK ZONE STANDARDS

SHEET NO.	DESCRIPTION
45	WZ(RS)-16*

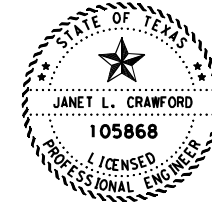

*THE STANDARD SHEETS SPECIFICALLY IDENTIFIED ABOVE HAVE BEEN ISSUED BY ME AND ARE APPLICABLE TO THIS PROJECT.

DocuSigned by:
Janet Crawford, PE
 4/28/2021
 DATE



INDEX SHEET

REVISIONS	FED. RD. DIV. NO.	STATE PROJECT NO.		SHEET NO.
		6	RMC 6379-54-001	
	STATE	DISTRICT	COUNTY	
	TEXAS	02	JOHNSON	
	CONTROL	SECTION	JOB	HIGHWAY NO.
	6379	54	001	SH174, ETC

Project Number: RMC 6379-54-001

Sheet 3A

County: JOHNSON

Control: 6379-54-001

Highway: SH174, ETC.

GENERAL NOTES:

Special Notes:

Contractor questions on this project are to be addressed to the following individual(s):

Area Engineer: **Janet Crawford** Janet.Crawford@txdot.gov
 Asst. Area Engineer: **Peter Ross** Peter.Ross@txdot.gov

Contractor questions will be accepted through email, phone, and in person by the above individuals.

All questions submitted that generate a response will be posted through this site. The site is organized by District, Project Type (Construction or Maintenance), Letting Date, CCSJ/Project Name.

All contractor questions will be reviewed by the Area Engineer or Assistant Area Engineer. Once a response is developed, it will be posted to TxDOT's Public FTP at the following Address:
<https://ftp.dot.state.tx.us/pub/txdot-info/Pre-Letting Responses/>

General:

Plans are required for this project. Plans may be obtained from one of the plan companies listed in the "Special Notice to Contractors", or viewed at Texas Department of Transportation's (TxDOT's) Internet site at <http://www.dot.state.tx.us/business/plansonline/agreement.htm>

Contract Prosecution: Each contract awarded by the Department stands on its own and as such, is separate from other contracts. A Contractor awarded multiple contracts must be capable and sufficiently staffed to concurrently process and/or execute all contracts and work orders at the same time.

Furnish crew(s) and equipment capable of maintaining work in a continuous manner for the completion of the work listed on the work order.

Personnel will be experienced in items of work in the contract, which they will be performing. Safety vests and hard hats will be pre-approved and worn at all times when outside vehicles within the work area. Safety vests shall be Class III.

Project Description - This project consists of **Call Out Reflectorized Pavement Markings** on various sections of highway within Johnson County as shown in the contract and defined in these general notes and specifications. Coordinate all work through the Maintenance Office listed below or their representative:

Project Number: RMC 6379-54-001

Sheet 3B

County: JOHNSON

Control: 6379-54-001

Highway: SH174, ETC.

Johnson
Maintenance Supervisor 2200 FM 2280 Cleburne, TX 76033 817-202-2900

Item 4.4. Changes In The Work. This contract may be extended in accordance with Special Provision 004--001.

Item 5.5. Cooperation of Contractor. Designate superintendent in accordance with second paragraph of Article 5.5. Cooperation of Contractor in the Standard Specifications for Construction and Maintenance of Highways, Streets, and Bridges.

Item 5.12.3. Multiple Work Orders. This contract will have multiple and concurrent work orders. No more than two (2) work orders will be issued to be performed at the same time. Work orders will include the location of the work, quantity of work, the number of working days allowed to complete the work order, and the date when the time charges for the work order will begin.

Item 7.2.4. Public Safety and Convenience. Personal vehicles will not be parked within the right-of-way at any time, including any section closed to the traveling public.

Operations will be curtailed or halted during special events that may result in delays or congestion to the traveling public.

No work that restricts or interferes with traffic shall be allowed from 3:00 pm on the day preceding the Holiday or Event to 9:00 am on the day after the Holiday or Event. The following Holiday/Event lane closure restriction requirements apply to this project:

Holiday Lane Closure Restrictions	
New Year's Eve and New Year's Day (December 31 through January 1)	3 PM December 30 through 9 AM January 2
Easter Holiday Weekend (Friday through Sunday)	3PM Thursday through 9 AM Monday
Memorial Day Weekend (Friday through Monday)	3 PM Thursday through 9 AM Tuesday
Independence Day (July 3 through July 5)	3 PM July 2 through 9 AM July 6
Labor Day Weekend (Friday through Monday)	3 PM Thursday through 9 AM Tuesday
Thanksgiving Holiday (Wednesday through Sunday)	3 PM Tuesday through 9 AM Monday

Project Number: RMC 6379-54-001

Sheet 3C

County: JOHNSON

Control: 6379-54-001

Highway: SH174, ETC.

Christmas Holiday (December 23 through December 26)	3 PM December 22 through 9 AM December 27
---	---

No lane closures within approximately 1 mile proximity (based on potential impact) of major retail traffic generators (i.e. malls) (Thanksgiving Day through January 2). This includes the events listed below:

Johnson County
Antique Alley Held 3 rd Friday, Saturday, Sunday in April & September

The above list of events is not all inclusive and should be added to or adjusted as needed. When deemed necessary, the Engineer will modify the list of major events when new events develop, existing events are rescheduled, or when warranted.

Modifications to Lane Closure / Work Restrictions:

Submit a request in writing for approval by the Engineer a minimum of 10 days in advance of implementing a change to lane closure restrictions.

When deemed necessary, the Engineer will lengthen, shorten, or otherwise modify lane closure restrictions as traffic conditions warrant.

Item 8.1. Prosecution of Work. Notification of work will be executed by work order. Notify section supervisor twenty-four (24) hours in advance of the date and time the Contractor plans to commence work. Upon issuance of initial work order all work orders thereafter shall begin operations within seventy-two (72) hours after verbal and/or written notification.

Item 8.3. Computation of Contract Time for Completion. Workings days will be charged in accordance with section 8.3.1.5. Calendar Day.

Item 8.3.2 Restricted Work Hours. Defines working days for this contract. Perform work according to the schedule below, unless otherwise approved.

Daytime Work	Nighttime Work
9:00 am – 4:00 pm Monday – Friday Saturday (Optional)	8:00 pm – 5:00 am Sunday – Thursday

Project Number: RMC 6379-54-001

Sheet 3D

County: JOHNSON

Control: 6379-54-001

Highway: SH174, ETC.

Provide a 48 hour advance notice for work on Saturday. Work on national holidays and daytime work on Sundays will not be permitted without written authorization.

Working day charges for nighttime work will be charged against the night in which work begins.

Item 8.6. Failure to Complete Work on Time. The response time specified in the contract is an essential element. Liquidated damages will be assessed when the Contractor fails to begin work within the specified response times for any Item(s). The dollar amount specified in this contract will be deducted from any money due or to become due for any Item(s) and will continue to be deducted for each day until work begins. This amount will be assessed not as penalty, but as liquidated damages. Failure to complete a project in the working days specified in the work order, time charges will continue for each working day until work is completed for that work order. The amount assessed for liquidated damages will be based on the total value of the original contract, in accordance with Special Provision 000-658, not the estimated amount on individual work orders.

Item 9.2. Plans Quantity Measurement. This contract is for callout work and work orders, plans quantity measurement requirement are not applicable.

Item 9.6. Payment for Material on Hand (MOH). This contract is callout work. Payment for MOH will only be made for materials by written approval of the Engineer.

Item 500. Mobilization: Paid by each work order issued.

Item 502. Barricades, Signs, and Traffic Handling Provide equipment such as trucks, trailers, autos, etc., with highly visible omni-directional warning flashing lights. These lights will be used within the work zone at all times. Provide forward facing arrow panel on lead vehicles when working in a continuous turn lanes. The Engineer will approve all equipment and vehicles prior to use.

All traffic control is subsidiary to the various bid items in accordance with Section 502.4.1.6, with the exception of Special Specification 6185, Contracts with Callout Work and Work Orders in the Standard Specifications For Construction And Maintenance Of Highways, Streets, And Bridges.

Mount signs on their own stands. Attach two (2) brightly colored safety flags to each sign. Do not hang or lean signs on or against any other sign post or delineator post. Erect signs in such a manner that they will not obstruct the traveling public's view of normal roadway signing or obstruct sight distance at intersections or curves.

Shadow vehicles equipped with Truck-Mounted Attenuators (TMA's) are required as shown on all Traffic Control Plan (TCP) Standards. Striping will be required on the back panel of truck mounted attenuators, and will be 8 inches of red and white stripes placed on an inverted "V" design. Sheeting will conform to departmental material Specification D-9-8300, Type "C".

Project Number: RMC 6379-54-001**Sheet 3E****County:** JOHNSON**Control: 6379-54-001****Highway:** SH174, ETC.

Provide signing and traffic control in compliance with the Texas Manual on Uniform Traffic Control Devices (TMUTCD), latest edition, and the appropriate traffic control method as outlined in the TMUTCD, and elsewhere in the plans.

Portable Changeable Message Signs (PCMS) shown on the Traffic Control Plan sheets (TCP's) as "optional" will be required on this contract.

Lane closures will be required on roadways as indicated in the plans and will be a maximum of two (2) miles from beginning of taper to end of closure. Lane closures will also be required on roadways allowing mobile operations in areas with inadequate field of view as determined by the Engineer.

Provide a Department Approved Truck Mounted Attenuator (TMA) behind all equipment overhanging roadway travel lanes. Trailer all slow moving vehicles (designed to operate 25mph or less) crossing freeway main lanes.

Dedicated personnel must be on duty to maintain barricades.

Equipment and materials will not be left within thirty feet (30') of the travel lane during non-working hours.

If off-duty uniformed officers are to be used during daytime hours, obtain prior approval from the Engineer. Nighttime closures will require off-duty uniformed police officer(s) in marked police vehicle(s) with jurisdiction and full police power in the city or county where the work is being performed. Determine and agree upon the number of officers in advance of the work. Off-duty officers will be paid for through force account. Fill out Form 318 "Daily Report on Law Enforcement" to check against invoice for officers.

Provide Multi-Directional Lighting Device (MDLD) for nighttime work with the following quality requirements:

- Provide a 2000 watt (minimum) SIROCCO lighting balloon, Airstar lighting or equivalent
- It is the intent of the MDLD lighting to supplement the Portable Road Light and Power Unit used to illuminate work areas during night work hours.
- Provide MDLD units which can self-inflate and are capable of illuminating approximately 15,000 sq. ft.
- Provide MDLD units of 1.1 meter horizontal diameter and capable of withstanding 60 mph winds when fully inflated and operating.

Provide MDLD units with two (2) 1,000 watt halogen bulbs recommended by the manufacturer.

Item 666. Reflectorized Pavement Markers. Minimum production rates will be as follows:

General Notes

Sheet E

Project Number: RMC 6379-54-001**Sheet 3F****County:** JOHNSON**Control: 6379-54-001****Highway:** SH174, ETC.

25 – Arrows/Words, or
1250 LF – 12" or 24" White/Yellow Solid
10,000 LF – 4", 6" or 8" White/Yellow

No minimum call out quantity for handwork.

Minimum call-out for long line per work order will be 10,000 linear feet.

Situations may require to be called out for less than the minimum in the maintenance section. If the section has less than the minimum call out, the specified minimum will be paid.

When required, an acrylic sealant will be used as a sealer for all Type I markings.

TxDOT is responsible for center dotting. If Contractor elects to do additional layout work, this will be considered subsidiary to striping operations and additional time will not be granted. Removal of temporary pavement marking tape will be considered subsidiary to the striping operations.

Handwork which requires less than 15 minutes at one (1) location will be treated as a mobile operation, otherwise complete lane closure will be required.

Item 672. Raised Pavement Markers. No minimum call out quantity for this item.

Furnish RPMs free of rust, scale, dirt, oil, grease, moisture, and contaminants that might adversely affect the adhesive bond.

The required production rate is 500 each per day. If elimination is needed, those quantities will not be added to the daily production rate nor will any additional days be added.

Elimination may be required but will not be paid for directly and is considered subsidiary to these items, this includes removal of temporary pavement marking tabs and/or tape.

Bituminous adhesive will not be allowed on concrete pavement.

Item 677. Eliminating Existing Pavement Markings and Markers. Perform elimination in accordance with Item 677.4.4 Mechanical Method.

The amount of long line striping elimination required per normal working day will be 1,000 linear feet.

Item 6001. Portable Changeable Message Sign. Provide electronic portable changeable message sign unit(s) as directed.

General Notes

Sheet F

Project Number: RMC 6379-54-001

Sheet 3G

County: JOHNSON

Control: 6379-54-001

Highway: SH174, ETC.

If more than one (1) crew works on the same day, but in different locations, each crew will use portable changeable message signs and arrow panels.

Each sign will have the following eighteen (18) messages programmed in its permanent memory:

1. Ramp Closed Ahead
2. Use Other Routes
3. Right Lane Closed
4. Left Lane Closed
5. Closed Ahead
6. Two Lane
7. Detour Ahead
8. Thru Traffic
9. Be Prepared To Stop
10. Merging Traffic
11. Expect 15 Minute Delay
12. Max Speed **MPH
13. Merge Right
14. Merge Left
15. No Exit Next ** Miles
16. Various Lanes Closed
17. Two Left Lanes Closed
18. Two right Lanes Closed

Item 6185. Truck Mounted Attenuators (TMA). The total number of truck mounted attenuators (TMA) required when utilizing the traffic control standards are shown in the tables below.

TCP 1 Series	Scenario	Required TMA
(1-1)-18		1
(1-2)-18		1
(1-3)-18	A	1
	B	2
(1-4)-18		1
(1-5)-18		1

Project Number: RMC 6379-54-001

Sheet 3H

County: JOHNSON

Control: 6379-54-001

Highway: SH174, ETC.

TCP 2 Series	Scenario	Required TMA
(2-2)-18	All	1
(2-3)-18	A	1
	B	2
(2-4)-18	All	1
(2-6)-18	All	1

TCP 3 Series	Scenario	Required TMA
(3-1)-13	All	2
(3-2)-13	All	3
(3-3)-14	A	2
	B	2
	C	3
	D	2
(3-4)-13	All	1, unless working inside a left turn lane, then 2.
(3-5)-18	All	1

Project Number: RMC 6379-54-001**Sheet 31****County:** JOHNSON**Control:** 6379-54-001**Highway:** SH174, ETC.

TCP 6 Series	Scenario	Required TMA
(6-1)-12	A	1
	B	2
(6-2)-12	All	1
(6-3)-12	All	1
(6-4)-12	A	1
	B	2

Shadow vehicles equipped for truck mounted attenuators (TMA) for mobile and stationary operations must be available for use at any time as determined by the Engineer.

The Contractor will be responsible for determining if one or more of these operations will be ongoing at the same time to determine the total number of TMA needed for the project for those times per plan requirements. Additional TMAs used that are not specified in the plans in which the Contractor expects compensation will require prior approval from the Engineer

ESTIMATE SUMMARY

								PROJECT RMC 637954001 CONTROL 6379-54-001		A L T	ITEM- CODE			DESCRIPTION	U N I T	TOTAL			
								SH 174, ETC ALL BID ITEMS			ITEM NO.	DESC CODE	SP NO			EST.	FINAL	EST.	FINAL
EST.	FINAL	EST.	FINAL	EST.	FINAL	EST.	FINAL	EST.	FINAL										
										500	6033		MOBILIZATION (CALLOUT)	EA		12.00			
										666	6262	007	REFL PAV MRK TY I (W)12"(SLD)(090MIL)	LF		3,000,000			
										666	6265	007	REFL PAV MRK TY I (W)24"(SLD)(090MIL)	LF		2,000,000			
										666	6267	007	REFL PAV MRK TY I (W)(ARROW)(090MIL)	EA		150,000			
										666	6269	007	REFL PAV MRK TY I (W)(DBL ARROW)(090MIL)	EA		16,000			
										666	6273	007	REFL PAV MRK TY I (W)(WORD)(090MIL)	EA		150,000			
										666	6271	007	REFL PAV MRK TY I (W)(RR XING)(090MIL)	EA		6,000			
										666	6224	007	PAVEMENT SEALER 4"	LF		750,000			
										666	6226	007	PAVEMENT SEALER 8"	LF		750,000			
										666	6254	007	RE PM TY II(W)4"(BRK)(090MIL)(CALLOUT)	LF		50,000,000			
										666	6255	007	RE PM TY II(W)4"(SLD)(090MIL)(CALLOUT)	LF		250,000,000			
										666	6259	007	RE PM TY II(W)8"(SLD)(090MIL)(CALLOUT)	LF		23,500,000			
										666	6275	007	RE PM TY II(Y)4"(BRK)(090MIL)(CALLOUT)	LF		10,000,000			
										666	6276	007	RE PM TY II(Y)4"(SLD)(090MIL)(CALLOUT)	LF		250,000,000			
										666	6277	007	RE PM TY II(Y)8"(SLD)(090MIL)(CALLOUT)	LF		2,500,000			
										672	6007		REFL PAV MRKR TY I-C	EA		450,000			
										672	6009		REFL PAV MRKR TY II-A-A	EA		3,000,000			
										672	6010		REFL PAV MRKR TY II-C_R	EA		3,000,000			
										677	6001		ELIM EXT PAV MRK & MRKS (4")	LF		1,000,000			
										677	6003		ELIM EXT PAV MRK & MRKS (8")	LF		1,000,000			
										6001	6001		PORTABLE CHANGEABLE MESSAGE SIGN	DAY		6,000			
										6065	6001		TRANSVERSE OR IN-LANE RUMBLE STRIPS	LF		1,000,000			
										6185	6005		TMA MOBILE OPERATION	DAY		100,000			

ESTIMATE & QUANTITY SHEET

STATE DIST. NO.	COUNTY	PROJECT NO.	SHEET NO.
2	JOHNSON	RMC 6379-54-001	4

Call Out ReflectORIZED Pavement Markings & Markers

Location	500 6033	666 6262-007	666 6265-007	666 6267-007	666 6269-007	666 6273-007	666 6271-007	666 6254-007	666 6255-007	666 6259-007	666 6275-007	666 6276-007	666 6277-007
	MOBILIZATION (CALLOUT)	REFL PAV MRK TY I (W)12"(SLD) (090MIL)	REFL PAV MRK TY I (W)24"(SLD) (090MIL)	REFL PAV MRK TY I (W)(ARROW) (090MIL)	REFL PAV MRK TY I(W) (DBL ARROW) (090MIL)	REFL PAV MRK TY I (W)(WORD) (090MIL)	REFL PAV MRK TY I (W)(RR XING) (090MIL)	RE PM TY I(W)4"(BRK) (090MIL) (CALLOUT)	RE PM TY I(W)4"(SLD) (090MIL) (CALLOUT)	RE PM TY I (W)8"(SLD) (090MIL) (CALLOUT)	RE PM TY I (Y)4"(BRK) (090MIL) (CALLOUT)	RE PM TY I (Y)4"(SLD) (090MIL) (CALLOUT)	RE PM TY I (Y)8"(SLD) (090MIL) (CALLOUT)
	EA	LF	LF	EA	EA	EA	EA	LF	LF	LF	LF	LF	LF
JOHNSON COUNTY	12	3,000	2,000	150	16	150	6	50,000	250,000	23,500	10,000	250,000	2,500

Location	666 6224-007	666 6226-007	672 6007	672 6009	672 6010	672 6001	677 2003	6001	6065	6185
	PAVEMENT SEALER 4"	PAVEMENT SEALER 8"	REFL PAV MRKR TY I-C	REFL PAV MRKR TY II-A-A	REFL PAV MRKR TY II-C-R	ELIM EXT PAV MRK & MRKS 4"	ELIM EXT PAV MRK & MRKS 8"	PORTABLE CHANGEABLE MESSAGE SIGN	TRANSVERSE OR IN-LANE RUMBLE STRIPS	TMA MOBILE OPERATION
	LF	LF	EA	EA	EA	LF	LF	EA	LF	DAY
JOHNSON COUNTY	750	750	450	3,000	3,000	1,000	1,000	6	1,000	100

 **Texas Department of Transportation**

PROJECT LIMITS

REVISIONS	FED. RD. DIV. NO.	STATE PROJECT NO.		SHEET NO.
	6	RMC 6379-54-001		5
	STATE	DISTRICT	COUNTY	
	TEXAS	02	JOHNSON	
	CONTROL	SECTION	JOB	HIGHWAY NO.
	6379	54	001	SH174, ETC

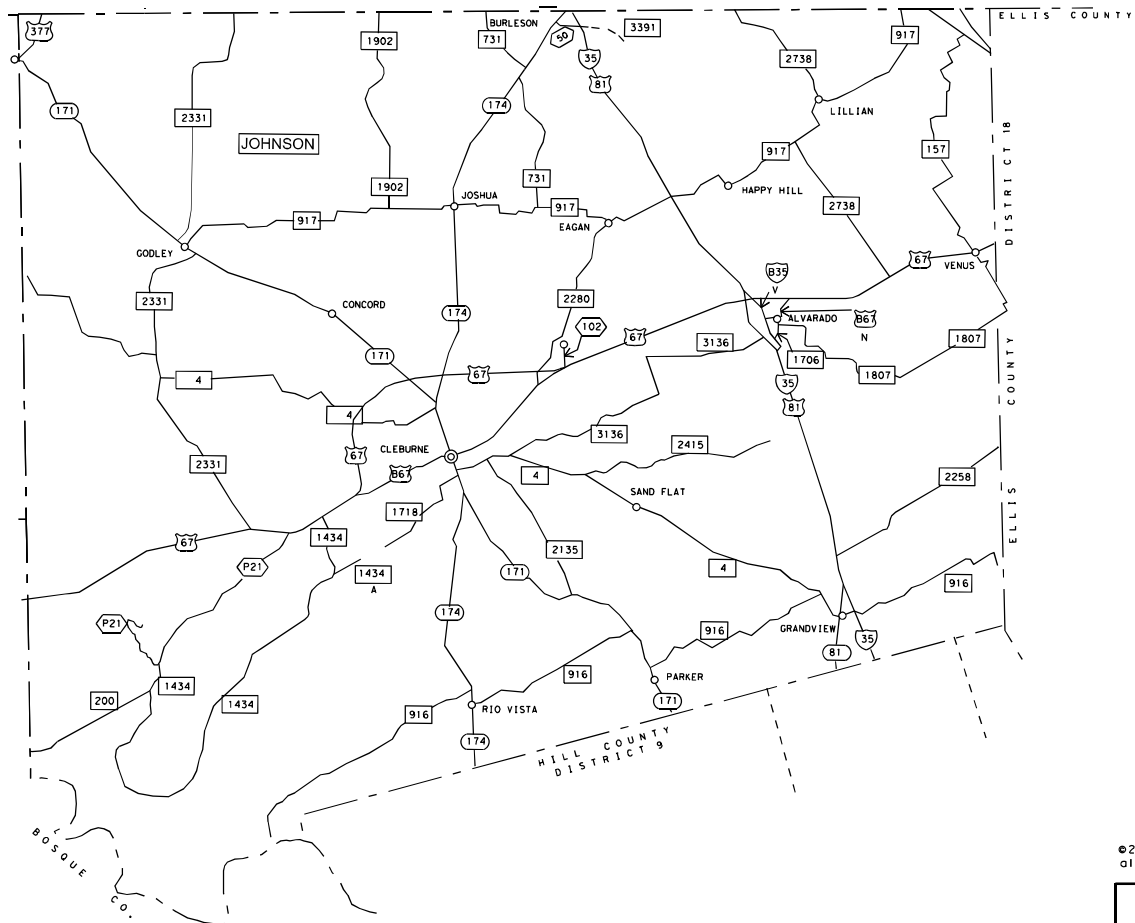

**CALLOUT REFLECTORIZED PAVEMENT MARKINGS AND MARKERS
MAINTENANCE SECTION 01- JOHNSON COUNTY**

©2021 by Texas Department of Transportation;
all rights reserved



PROJECT LOCATION MAP

C.O	FED. RD. DIV. NO.	STATE PROJECT NO.		SHEET NO.
			RMC 637954001	
REVISIONS	STATE	DISTRICT	COUNTY	
	TEXAS	02	JOHNSON	
	CONTROL	SECTION	JOB	HIGHWAY NO.
	6379	54	001	SH174, ETC

DISCLAIMER: This standard is governed by the "Texas Engineering Practice Act". No warranty of any kind is made by TxDOT for any purpose whatsoever. TxDOT assumes no responsibility for the conversion of this standard to other formats or for incorrect results or damages resulting from its use.

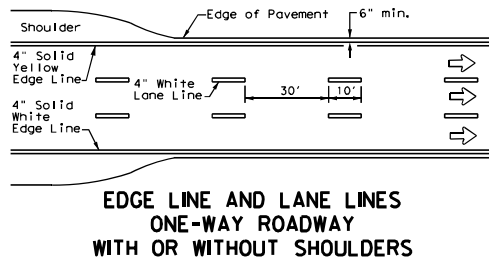

**EDGE LINE AND LANE LINES
ONE-WAY ROADWAY
WITH OR WITHOUT SHOULDERS**

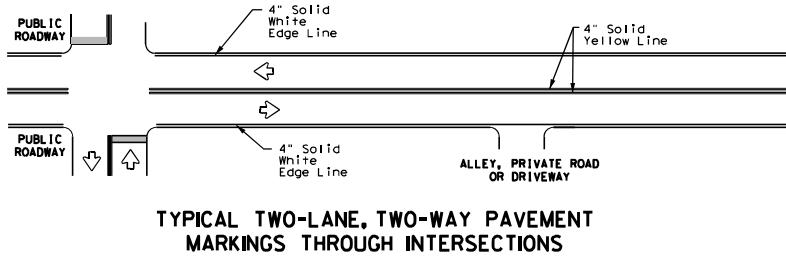

**TYPICAL TWO-LANE, TWO-WAY PAVEMENT
MARKINGS THROUGH INTERSECTIONS**

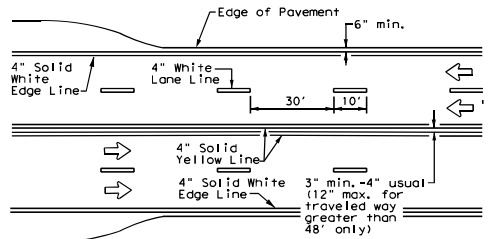

**CENTERLINE AND LANE LINES
FOUR LANE TWO-WAY ROADWAY
WITH OR WITHOUT SHOULDERS**

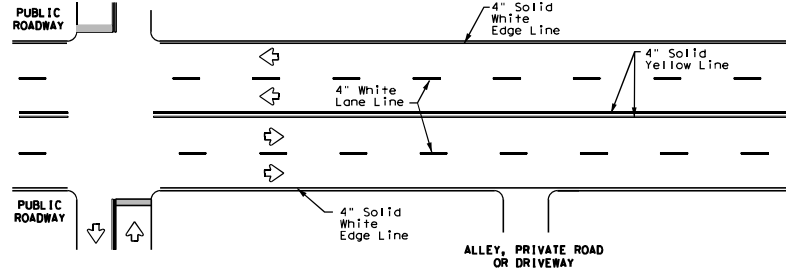

**TYPICAL MULTI-LANE, TWO-WAY PAVEMENT
MARKINGS THROUGH INTERSECTIONS**

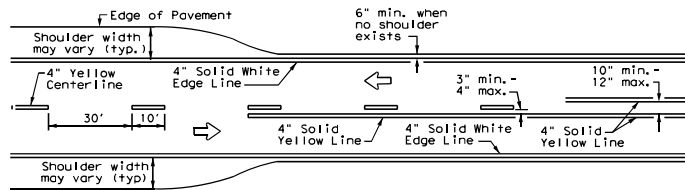

**TWO LANE TWO-WAY ROADWAY
WITH OR WITHOUT SHOULDERS**

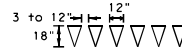

For posted speed on road being marked equal to or less than 40 MPH.

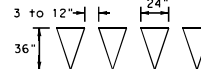

For posted speed on road being marked equal to or greater than 45 MPH.

YIELD LINES

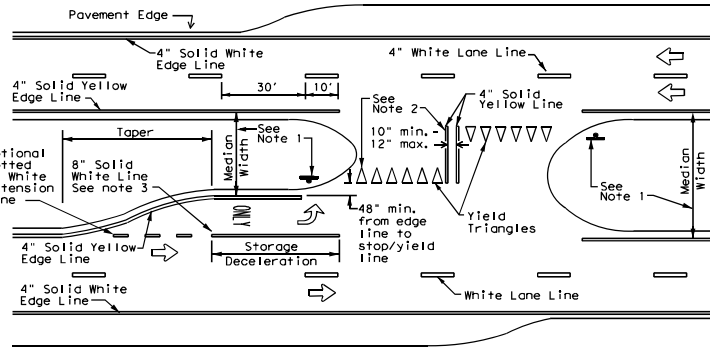

FOUR LANE DIVIDED ROADWAY CROSSOVERS

NOTES

- Where divided highways are separated by median widths at the median opening itself of 30 feet or more, median openings shall be signed as two separate intersections. Each median opening has two width measurements, with one measurement for each approach. The narrow median width will be the controlling width to determine if signs are required. Yield signs are the typical intersection control. Stop signs are optional as determined by the Engineer.
- Install median striping (double yellow centerlines and stop bars/yield triangles) when a 50' or greater median centerline can be placed. Stop bars shall only be used with stop signs. Yield triangles shall only be used with yield signs.
- Length of turn bays, including taper, deceleration, and storage lengths shall be as shown on the plans or as directed by the Engineer.

GENERAL NOTES

- Edgeline striping shall be as shown in the plans or as directed by the Engineer. The edgeline should not be placed less than 6 inches from the edge of pavement. This distance may vary due to pavement ravelling or other conditions. Edgelines are not required in curb and gutter sections of roadways.
- The traveled way includes only that portion of the roadway used for vehicular travel. It does not include the parking lanes, sidewalks, berms and shoulders. The traveled ways shall be measured from the inside of edgeline to the inside of edgeline of a two lane roadway.

MATERIAL SPECIFICATIONS

PAVEMENT MARKERS (REFLECTORIZED)	DMS-4200
EPOXY AND ADHESIVES	DMS-6100
BITUMINOUS ADHESIVE FOR PAVEMENT MARKERS	DMS-6130
TRAFFIC PAINT	DMS-8200
HOT APPLIED THERMOPLASTIC	DMS-8220
PERMANENT PREFABRICATED PAVEMENT MARKINGS	DMS-8240

All pavement marking materials shall meet the required Departmental Material Specifications as specified by the plans.

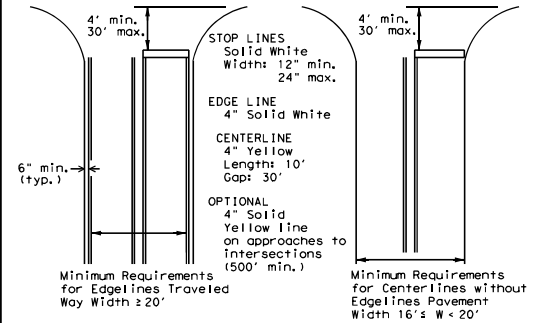

**GUIDE FOR PLACEMENT OF STOP LINES,
EDGE LINE & CENTERLINE**

Based on Traveled Way and Pavement Widths for Undivided Highways



Texas
Traffic
Safety
Division
Standard

**TYPICAL STANDARD
PAVEMENT MARKINGS**

PM(1)-20

FILE:	pm-20.dgn	DATE:	REV:	BY:	CHK:	APP:	DATE:
①	TxDOT	November 1978					
8-95	3-03	REVISIONS	6378	54	001	SH 174, ETC	
5-00	2-12						
2-00	6-20						
			02	JOHNSON		7	

DATE:
FILE:

REFLECTIVE RAISED PAVEMENT MARKERS FOR VEHICLE POSITIONING GUIDANCE

DISCLAIMER: This standard is governed by the "Texas Engineering Practice Act". No warranty of any kind is made by TxDOT for any purpose whatsoever. TxDOT assumes no responsibility for the conversion of this standard to other formats or for incorrect results or damages resulting from its use.

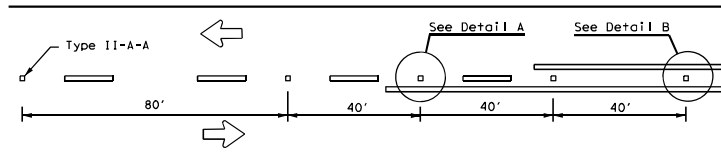

CENTERLINE FOR ALL TWO LANE ROADWAYS

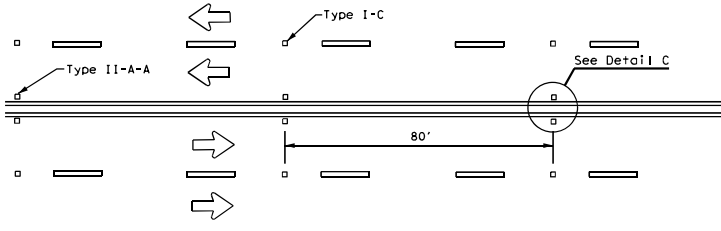

**CENTERLINE & LANE LINES
FOR FOUR LANE TWO-WAY HIGHWAYS**

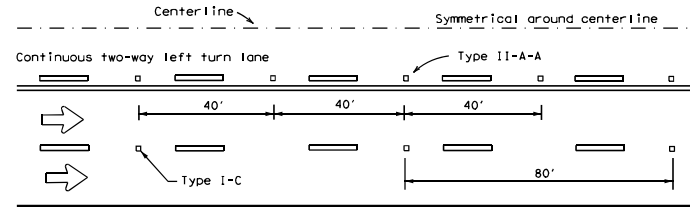
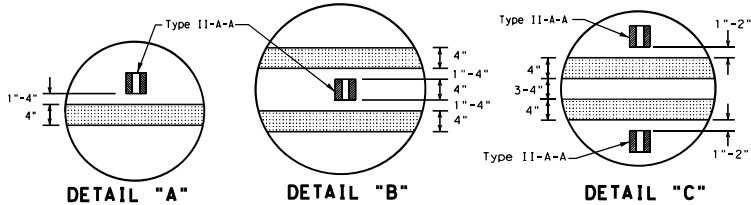

CENTERLINE AND LANE LINES FOR TWO-WAY LEFT TURN LANE

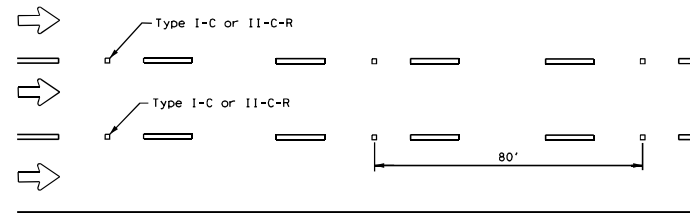

LANE LINES FOR ONE-WAY ROADWAY (NON-FREWAY FACILITIES)

Raised pavement markers Type II-C-R shall have clear face toward normal traffic and red face toward wrong-way traffic.

MATERIAL SPECIFICATIONS	
PAVEMENT MARKERS (REFLECTORIZED)	DMS-4200
EPOXY AND ADHESIVES	DMS-6100
BITUMINOUS ADHESIVE FOR PAVEMENT MARKERS	DMS-6130
TRAFFIC PAINT	DMS-8200
HOT APPLIED THERMOPLASTIC	DMS-8220
PERMANENT PREFABRICATED PAVEMENT MARKINGS	DMS-8240

All pavement marking materials shall meet the required Departmental Material Specifications as specified by the plans.

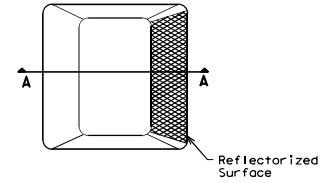

Type I (Top View)

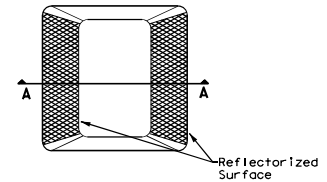

Type II (Top View)

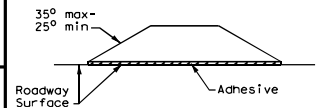

RAISED PAVEMENT MARKERS



POSITION GUIDANCE USING RAISED MARKERS REFLECTORIZED PROFILE MARKINGS PM(2) -20

FILES	pm2-20.dgn	DWG	CRK	DWG	CRK
4-92	2-10	REVISED	6319	54	001
5-00	2-12				
5-00	6-20		02	JOHNSON	8

GENERAL NOTES

- All raised pavement markers placed in broken lines shall be placed in line with and midway between the stripes.
- On concrete pavements the raised pavement markers should be placed to one side of the longitudinal joints.

REFLECTORIZED PROFILE PATTERN DETAIL

USING REFLECTIVE PROFILE PAVEMENT MARKINGS

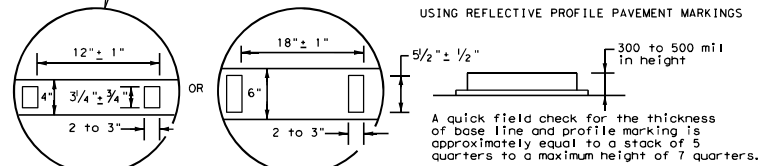

NOTE

Profile markings shall not be placed on roadways with a posted speed limit of 45 MPH or less.

DATE: FILE:

DISCLAIMER: This standard is governed by the "Texas Engineering Practice Act". No warranty of any kind is made by TxDOT for any purpose whatsoever. TxDOT assumes no responsibility for the conversion of this standard to other formats or for incorrect results or damages resulting from its use.

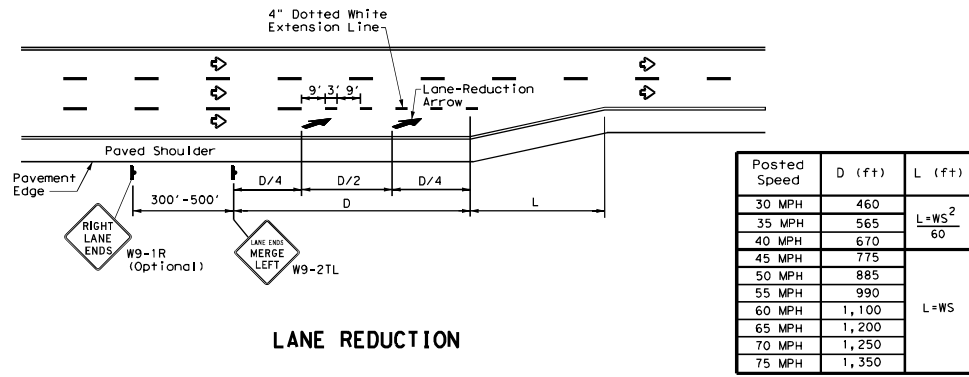

LANE REDUCTION

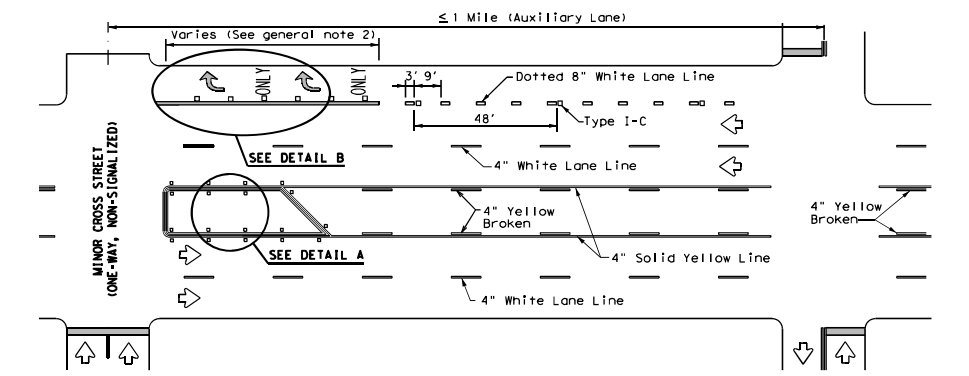

TYPICAL TWLTL AT ONE-WAY STREET AND RIGHT TURN AUXILIARY LANE

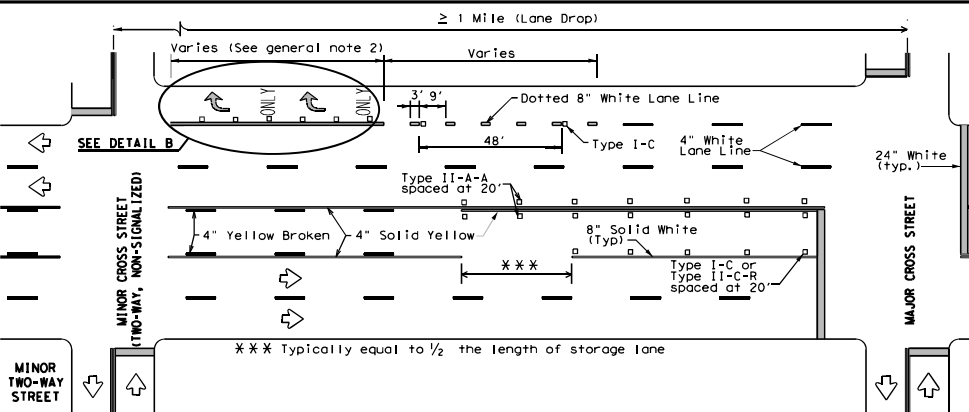

TYPICAL TWLTL AT TWO-WAY CROSS STREET AND RIGHT TURN LANE DROP

NOTES

- Lane reduction pavement markings are used where the number of through lanes is reduced because of narrowing of the roadway or because of a section of on-street parking in what would otherwise be a through lane. For Texas Super 2 Passing Lanes, see T52(PL) standard sheets.
- On divided highways, an additional W9-1R "RIGHT LANE ENDS" sign may be installed in the median aligned with the W9-1R sign on the right side of the highway.
- Lane reduction arrows are required for speeds of 45 mph or greater. An optional third lane reduction arrow may be added based on engineering judgement. If used, the optional third lane reduction arrow should be centered between the first and last lane reduction arrows.
- For lane reductions on Freeways and Expressways, signing shall conform to the TxDOT Freeway Signing Handbook.

GENERAL NOTES

- Lane use word and arrow markings shall be used where through lanes approaching an intersection become mandatory turn lanes. Lane use word and arrow markings should be used in auxiliary lanes of substantial length. Lane use arrow markings or word and arrow markings may be used in other lanes and turn bays for emphasis. Details for words and arrows are as shown in the Standard Highway Sign Designs for Texas.
- When lane-use words and arrow markings are used, two sets of arrows should be used if the length of the bay is greater than 180 feet. When a single lane use arrow or word and arrow marking is used for a short turn lane, it should be located at or near the upstream end of the full-width turn lane.
- Use raised pavement marker Type 1-C with undivided highways, flush medians and two way left turn lanes. Use raised pavement marker Type II-C-R with divided highways and raised medians.
- Length of turn bays, including taper, deceleration, and storage lengths shall be as shown on the plans or as directed by the Engineer.

MATERIAL SPECIFICATIONS

PAVEMENT MARKERS (REFLECTORIZED)	DMS-4200
EPOXY AND ADHESIVES	DMS-6100
BITUMINOUS ADHESIVE FOR PAVEMENT MARKERS	DMS-6130
TRAFFIC PAINT	DMS-8200
HOT APPLIED THERMOPLASTIC	DMS-8220
PERMANENT PREFABRICATED PAVEMENT MARKINGS	DMS-8240

All pavement marking materials shall meet the required Departmental Material Specifications as specified by the plans.

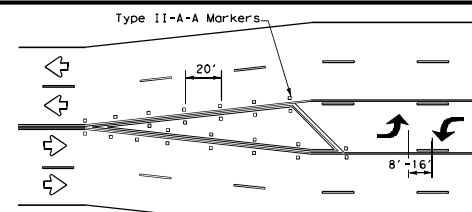

TYPICAL TRANSITION FOR TWLTL AND DIVIDED HIGHWAY

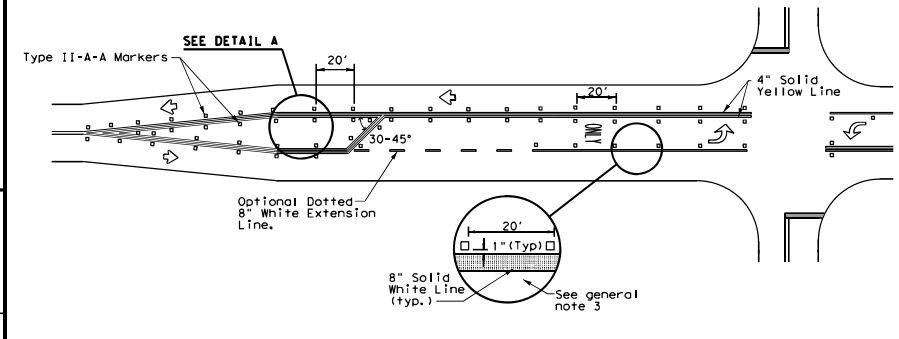

TYPICAL TWO-LANE HIGHWAY INTERSECTION WITH LEFT TURN BAYS

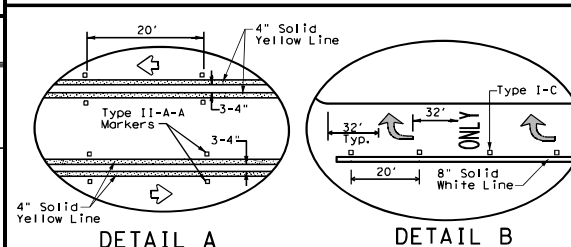

DETAIL A

DETAIL B

Texas Department of Transportation
Traffic Safety Division

TWO-WAY LEFT TURN LANES, RURAL LEFT TURN BAYS, AND LANE REDUCTION PAVEMENT MARKINGS PM(3)-20

FILE:	dm3-20.dgn	DN:	CK:	DN:	CK:
© TxDOT	Apr 11 1998	CON:	SECT:	JOB:	HIGHWAY:
5-00	2-10	6378	54	001	SH 174, ETC
8-00	2-12	DIST:	COUNTY:		
3-03	6-20	02	JOHNSON		SHEET NO. 9

DATE: FILE:

DISCLAIMER: This standard is governed by the "Texas Engineering Practice Act". No warranty of any kind is made by TxDOT for any purpose whatsoever. TxDOT assumes no responsibility for the conversion of this standard to other formats or for incorrect results or damages resulting from its use.

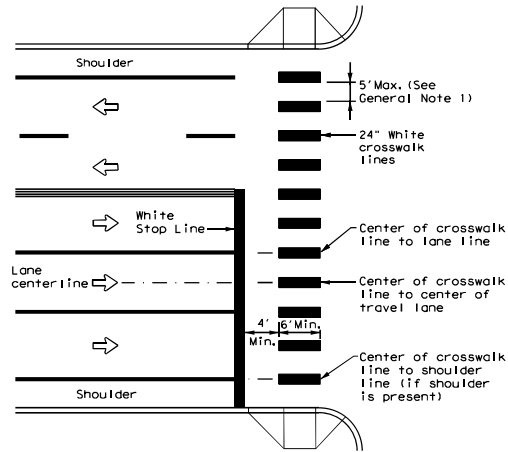

HIGH-VISIBILITY LONGITUDINAL CROSSWALK AT CONTROLLED APPROACH

GENERAL NOTES

1. Longitudinal crosswalk lines should not be placed in the wheel path of vehicles. Center the crosswalk lines on travel lanes, lane lines, and shoulder lines (if present).
2. A minimum 6' clear distance shall be provided to the curb face. If the last crosswalk line falls into this distance it must be omitted.
3. For divided roadways, adjustments in spacing of the crosswalk lines should be made in the median so that the crosswalk lines are maintained in their proper location across the travel portion of the roadway.
4. At skewed crosswalks, the crosswalk lines are to remain parallel to the lane lines.
5. Each crosswalk shall be a minimum of 6' wide.
6. The High-Visibility Longitudinal Crosswalk is the preferred crosswalk pattern on State Highways. Other crosswalk patterns as shown in the "Texas Manual on Uniform Traffic Control Devices" may be used. All crosswalk designs and dimension shall comply with the "Texas Manual on Uniform Traffic Control Devices."
7. Final placement of Stop Bar/Yield Triangles and Crosswalk shall be approved by the Engineer in the field.

MATERIAL SPECIFICATIONS

PAVEMENT MARKERS (REFLECTORIZED)	DMS-4200
EPOXY AND ADHESIVES	DMS-6100
BITUMINOUS ADHESIVE FOR PAVEMENT MARKERS	DMS-6130
TRAFFIC PAINT	DMS-8200
HOT APPLIED THERMOPLASTIC	DMS-8220
PERMANENT PREFABRICATED PAVEMENT MARKINGS	DMS-8240

All pavement marking materials shall meet the required Departmental Material Specifications as specified by the plans.

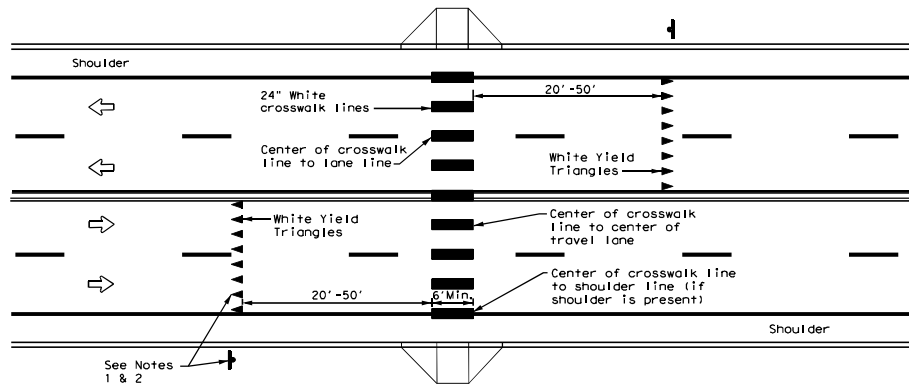

UNSIGNALIZED MID BLOCK HIGH-VISIBILITY LONGITUDINAL CROSSWALK

NOTES

1. Use yield triangles with "Yield Here to Pedestrians" signs at unsignalized mid block crosswalks.
2. Use stop bars with "Stop Here on Red" signs at mid block crosswalks controlled by traffic signals or pedestrian hybrid beacons.

DATE:
FILE:

		Texas Department of Transportation		Traffic Safety Division Standard	
<h2>CROSSWALK PAVEMENT MARKINGS</h2>					
<h3>PM (4) - 20</h3>					
FILE:	pm4-20.dgn	DN:		DK:	
© TxDOT:	June 2020	REV:		JOB:	HIGHWAY
REVISIONS		6378	54	001	SH 174, ETC.
DIST:	02	COUNTY:	JOHNSON	SHEET NO.:	10

DISCLAIMER: The use of this standard is governed by the "Texas Engineering Practices Act". No warranty, of any kind is made by TxDOT for any purpose whatsoever. TxDOT assumes no responsibility for the conversion of this standard to other formats or for incorrect results or damages resulting from its use.

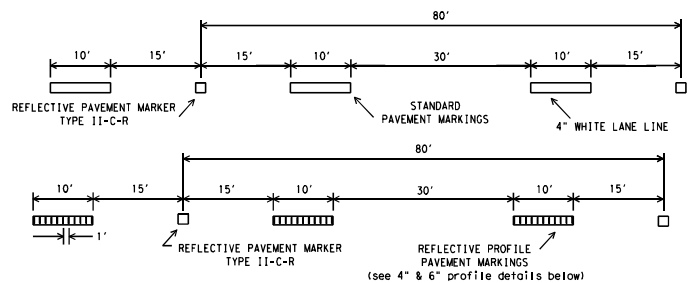

PAVEMENT MARKERS (REFL) TYPE 11-C-R SHALL BE SPACED ON 80' CENTERS WITH THE CLEAR FACE TOWARD NORMAL TRAFFIC AND THE RED FACE TOWARD WRONG WAY TRAFFIC.

TRAFFIC LANE LINES PAVEMENT MARKING DETAILS

EDGE LINES SHOULD TYPICALLY BE 4" WIDE AND THE MATERIALS SHALL BE AS SPECIFIED IN THE PLANS. IF RAISED PROFILE PAVEMENT MARKINGS ARE USED SEE DETAILS BELOW.

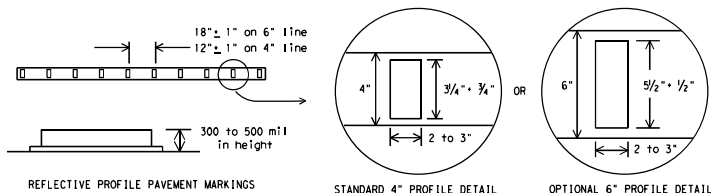

EDGE LINE PAVEMENT MARKINGS

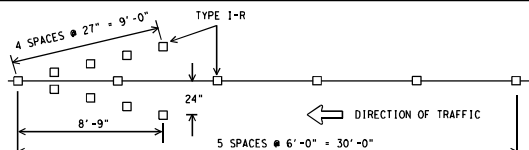

ALL RAISED MARKERS IN THE WRONG WAY ARROW SHALL BE TYPE 1-R REFLECTORIZED PAVEMENT MARKERS WITH THE REFLECTORIZED SURFACE FACING THE WRONG WAY TRAFFIC. TYPE 11-C-R SHALL NOT BE USED. REFLECTORIZED WRONG WAY ARROWS, NOT TO EXCEED TWO, MAY BE PLACED ON EXIT RAMP. LOCATION OF THE ARROWS SHALL BE AS SHOWN IN THE PLANS OR AS DIRECTED BY THE ENGINEER.

WRONG WAY ARROW DETAIL

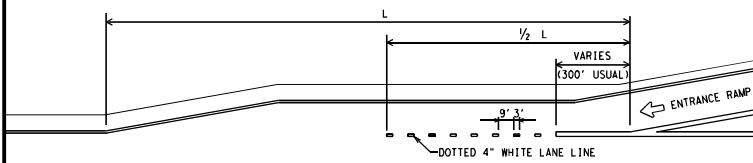

PARALLEL ACCELERATION LANE

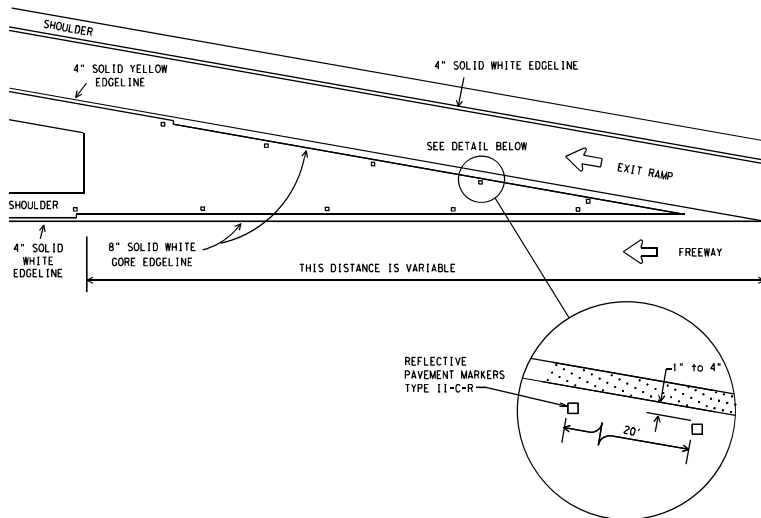

TYPICAL EXIT RAMP GORE MARKING

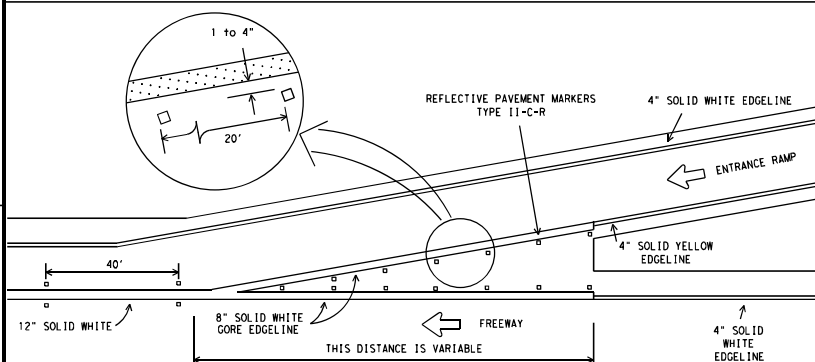

TYPICAL ENTRANCE RAMP GORE MARKING

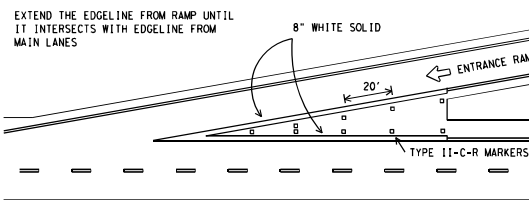

TAPERED ACCELERATION LANE

MATERIAL SPECIFICATIONS	
PAVEMENT MARKERS (REFLECTORIZED)	DMS-4200
EPOXY AND ADHESIVES	DMS-6100
BITUMINOUS ADHESIVE FOR PAVEMENT MARKERS	DMS-6130
TRAFFIC PAINT	DMS-8200
HOT APPLIED THERMOPLASTIC	DMS-8220
PERMANENT PREFABRICATED PAVEMENT MARKINGS	DMS-8240

All pavement marking materials shall meet the required Departmental Material Specifications as specified by the plans.

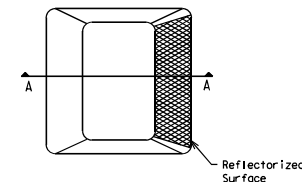

Type I (Top View)

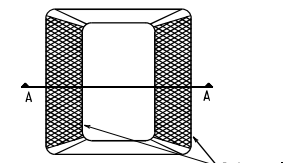

Type II (Top View)

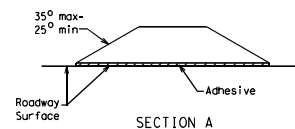

SECTION A

RAISED PAVEMENT MARKERS

Texas Department of Transportation
Traffic Operations Division

TYPICAL STANDARD FREEWAY PAVEMENT MARKINGS WITH RAISED PAVEMENT MARKERS FPM(1)-12

REVISIONS		DATE	BY	CHKD	APP'D	JOB	HIGHWAY
4-92	2-10	6379	54	001		SH 174, ETC	
5-00	2-12						
8-00							
2-08					02	JOHNSON	11

DISCLAIMER: The use of this standard is governed by the "Texas Engineering Practice Act". No warranty of any kind is made by TxDOT for any purpose whatsoever. TxDOT assumes no responsibility for the content or use of this standard or for incorrect results or damages resulting from its use.

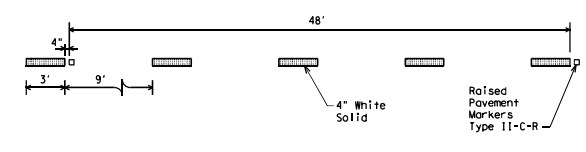
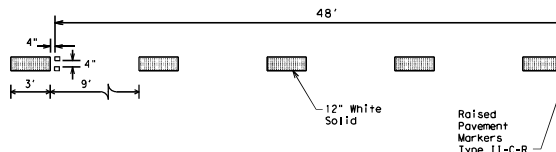
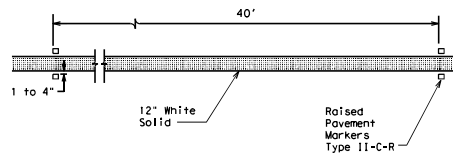
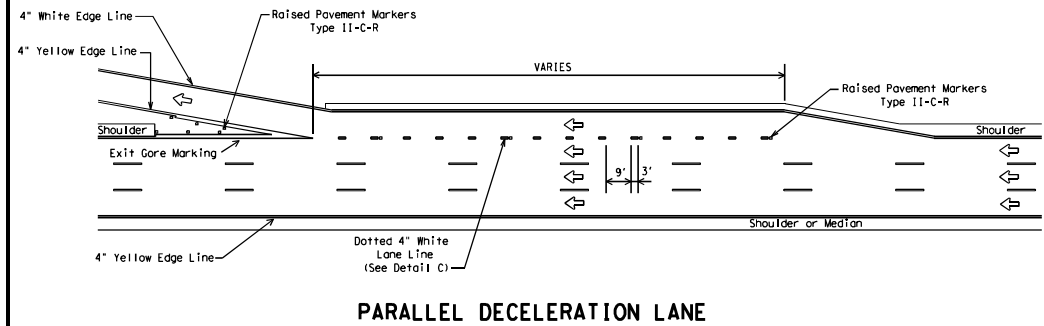
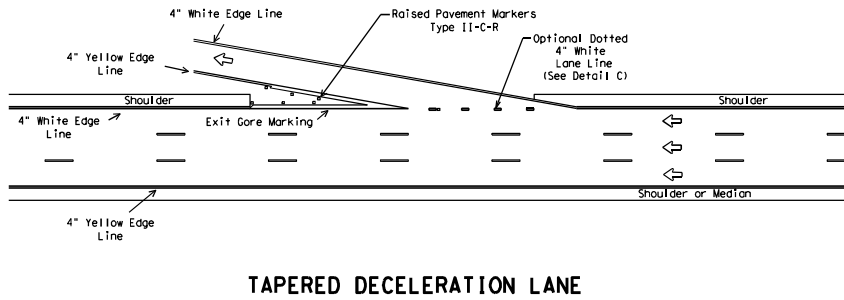
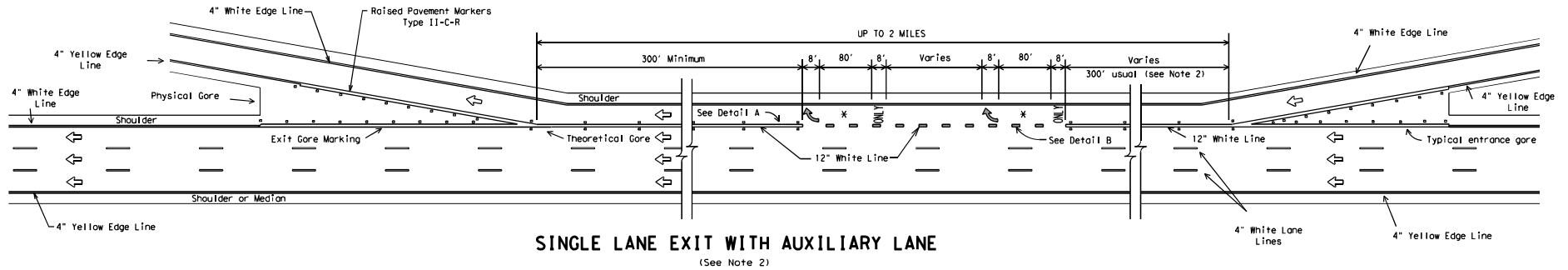

GENERAL NOTES

1. Pavement markings shall be white except as otherwise noted.
2. Length of 12" white line may vary depending on location.
3. Wide (12") Dotted Lane Line (See Detail B) is used to separate a through lane from a lane drop at normal exit ramp and from an auxiliary lane between an entrance and exit ramp.
4. Normal (4") Dotted Lane Line (See Detail C) is used at parallel acceleration and deceleration lanes.

LEGEND	
←	Denotes direction of traffic.
↔	Pavement marking arrows (white)
✱	Arrow markings are optional, however "ONLY" is required if arrow is used

MATERIAL SPECIFICATIONS	
PAVEMENT MARKERS (REFLECTORIZED)	DMS-4200
EPOXY AND ADHESIVES	DMS-6100
BITUMINOUS ADHESIVE FOR PAVEMENT MARKERS	DMS-6130
TRAFFIC PAINT	DMS-8200
HOT APPLIED THERMOPLASTIC	DMS-8220
PERMANENT PREFABRICATED PAVEMENT MARKINGS	DMS-8240

All pavement marking materials shall meet the required Departmental Material Specifications as specified by the plans.

**TYPICAL STANDARD
FREEWAY PAVEMENT MARKINGS
ENTRANCE AND EXIT RAMP**
FPM(2)-12

REVISIONS		DATE	BY	CHKD	DATE	BY	CHKD
4-92	2-10	6379	54	001	SH	174, ETC	
8-95	2-12				COUNTY	SHEET NO.	
5-00				02	JOHNSON	12	
8-00							

DATE:
FILE:

DISCLAIMER: The use of this standard is governed by the Texas Engineering Practice Act. No warranty of any kind is made by the State of Texas or the Department of Transportation for the accuracy, reliability, or completeness of this standard or for the results or damages resulting from its use.

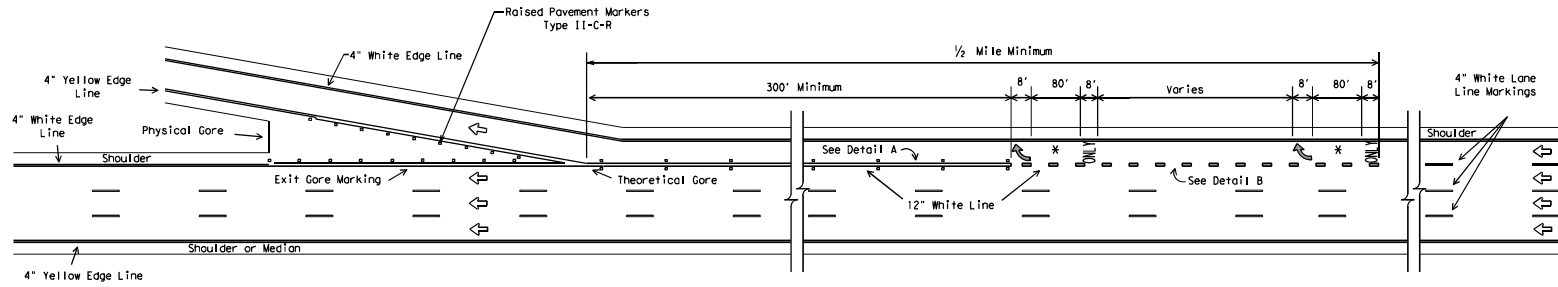

SINGLE LANE EXIT - LANE DROP OR EXIT ONLY

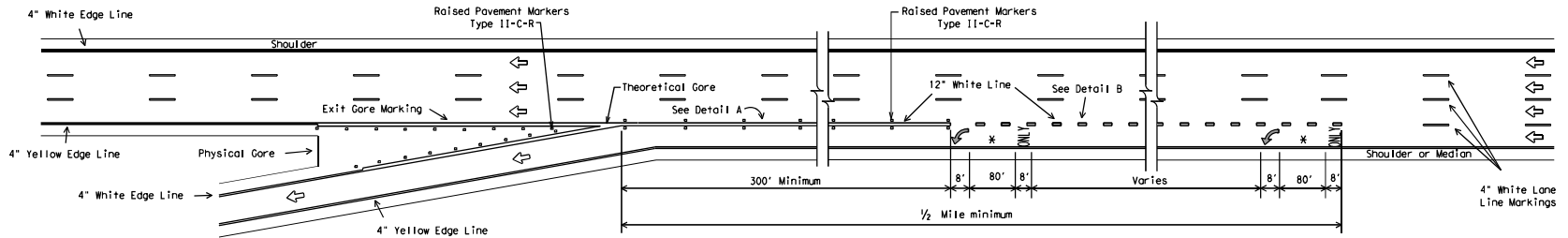

SINGLE LANE EXIT - LANE DROP OR EXIT ONLY (LEFTHAND)

LEGEND	
	Denotes direction of traffic.
	Pavement marking arrows (white)
	Arrow markings are optional, however "ONLY" is required if arrow is used

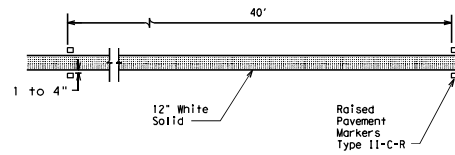

DETAIL A

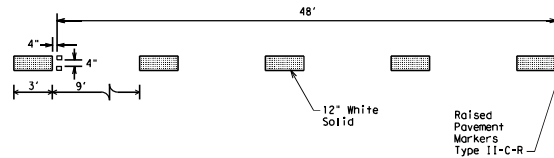

DETAIL B

Wide (12") Dotted Lane Line (See Note 3)

MATERIAL SPECIFICATIONS	
PAVEMENT MARKERS (REFLECTORIZED)	DMS-4200
EPOXY AND ADHESIVES	DMS-6100
BITUMINOUS ADHESIVE FOR PAVEMENT MARKERS	DMS-6130
TRAFFIC PAINT	DMS-8200
HOT APPLIED THERMOPLASTIC	DMS-8220
PERMANENT PREFABRICATED PAVEMENT MARKINGS	DMS-8240

All pavement marking materials shall meet the required Departmental Material Specifications as specified by the plans.

GENERAL NOTES

1. Pavement markings shall be white except as otherwise noted.
2. Length of 12" white line may vary depending on location.
3. Wide (12") Dotted Lane Line (See Detail B) is used to separate a through lane from a lane drop at normal exit ramp and from an auxiliary lane between an entrance and exit ramp.

Texas Department of Transportation
Traffic Operations Division

**TYPICAL STANDARD
FREEWAY PAVEMENT MARKINGS
LANE DROP (EXIT ONLY) EXIT RAMP**

FPM(3)-12

REV	DATE	BY	CHK	APP	DESCRIPTION
5-00	8-00	2-10	2-12		REVISED
6379	54	001	SH 174, ETC		
02		JOHNSON			

23C

DATE:
FILE:

DISCLAIMER: The use of this standard is governed by the "Texas Engineering Practice Act". No warranty of any kind is made by TxDOT for any purpose or purpose other than that for which it was developed. The user assumes all liability for any damage resulting from its use.

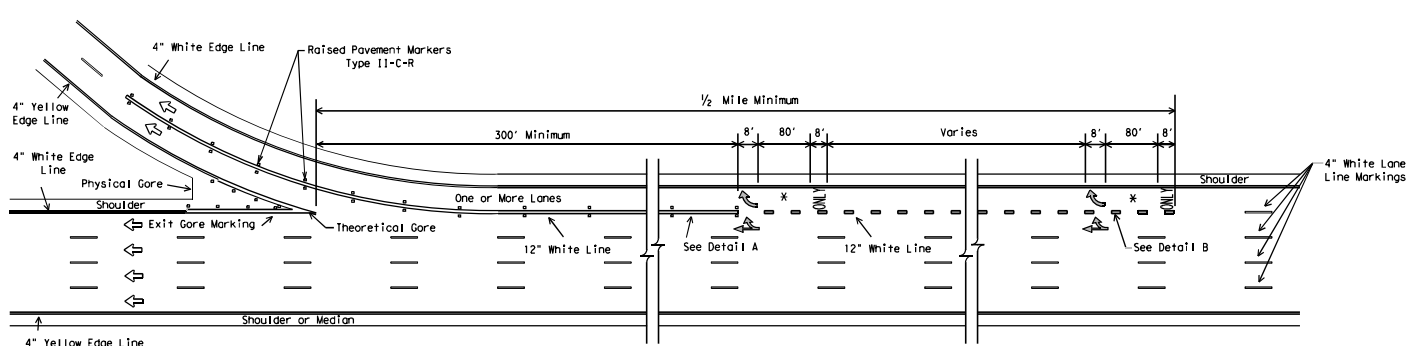

MULTIPLE LANE EXIT - EXIT ONLY WITH OPTION LANE

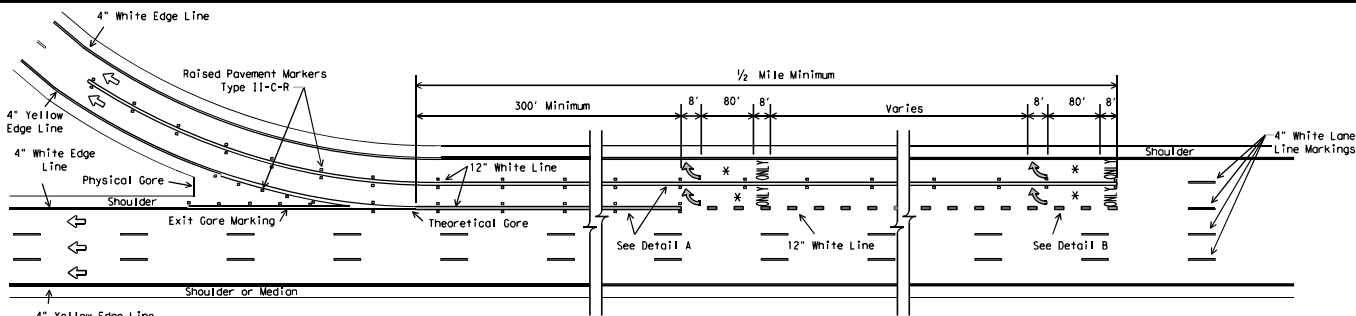

MULTIPLE LANE EXIT ONLY

LEGEND	
	Denotes direction of traffic
	Pavement marking arrow (white)
	Optional Pavement Marking Arrows (white)
	Arrow markings are optional, however "ONLY" is required if arrow is used

GENERAL NOTES

1. Pavement markings shall be white except as otherwise noted.
2. Length of 12" white line may vary depending on location.
3. Wide (12") Dotted Lane Line (See Detail B) is used to separate a through lane from a lane drop at normal exit ramp and from an auxiliary lane between an entrance and exit ramp.

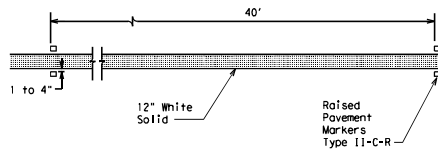

DETAIL A

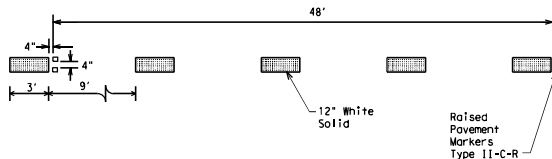

DETAIL B

Wide (12") Dotted Lane Line (See Note 3)

MATERIAL SPECIFICATIONS	
PAVEMENT MARKERS (REFLECTORIZED)	DMS-4200
EPOXY AND ADHESIVES	DMS-6100
BITUMINOUS ADHESIVE FOR PAVEMENT MARKERS	DMS-6130
TRAFFIC PAINT	DMS-8200
HOT APPLIED THERMOPLASTIC	DMS-8220
PERMANENT PREFABRICATED PAVEMENT MARKINGS	DMS-8240

All pavement marking materials shall meet the required Departmental Material Specifications as specified by the plans.

Texas Department of Transportation
Traffic Operations Division

**TYPICAL STANDARD
FREEWAY PAVEMENT MARKINGS
LANE DROP (EXIT ONLY) DETAILS**

FPM(4) - 12

© TxDOT Apr'1 1992		DN T XDOT	CA T XDOT	DN T XDOT	CA T XDOT
REVISIONS					
5-00	CONT	6379	54	001	SH 174, ETC
8-00	SECT				HIGHWAY
2-10	RIST				COUNTY
2-12		02		JOHNSON	SHEET NO.
		230		14	

DATE:
FILE:

DISCLAIMER: The use of this standard is governed by the "Texas Engineering Practice Act". No warranty of any kind is made by the author for the use of this standard to other formats or for incorrect results or damages resulting from its use.

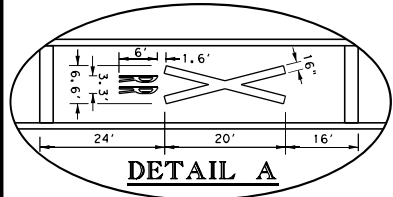
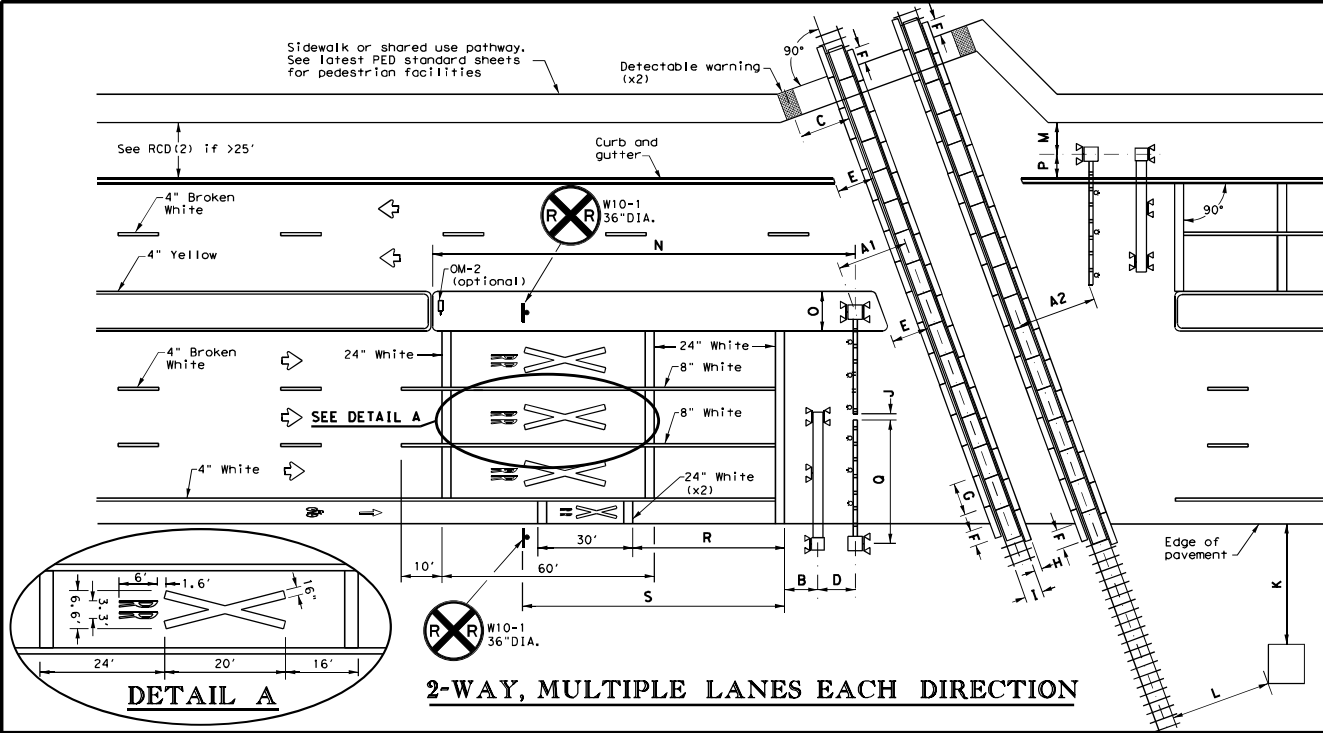

2-WAY, MULTIPLE LANES EACH DIRECTION

NOTES

- A1: Center of RR mast to center of rail: 12' minimum, 15' typical.
- A2: Tip of gate to center of rail: 12' minimum, 15' typical.
- B: Center of mast (cantilever, gate, or mast flasher) of nearest active traffic control device to stop line: 8' (NOTE: Stop line may be moved as needed, but should be at least 8' back from gates, if present).
- C: Center of detectable warning device to nearest rail: 6' minimum
- D: Center of gate mast to center of cantilever mast: 6' typical. NOTE: Cantilever may be located in front or behind gates.
- E: Edge of median or curb to nearest rail: 10' typical. NOTE: Design median edge to be parallel with rail.
- F: Edge of planking panel from edge of pavement or sidewalk: 3' minimum. NOTE: Field panels need not be in line with gauge panels.
- G: Length of panels along rail: 8' typical.
- H: Width of field panel: 2' typical (check with railroad company).
- I: Distance between rails: 4'-8.5'.
- J: Tip of gate to tip of gates: 2' maximum for Quiet Zone SSM or 90% of traveled way covered by gates for all other locations.
- K: Nearest edge of RR cabin from edge of pavement: 30' typical. NOTE: Cabinet not required to be parallel to edge of pavement.
- L: Nearest edge of RR cabin from nearest rail: 25' typical.
- M: Center of RR mast to edge of sidewalk: 6' minimum.
- N: Center of gate mast to leading edge of non-traversable median: 100' minimum to qualify as a Quiet Zone SSM. NOTE: 60' will suffice if there is a street intersection within the 100' and all street intersections within 60' are closed.
- O: Width of median: 8'-6" minimum, 10' typical when using median gates. Center of gate mast minimum 4'-3" from face of curb.
- P: Center of RR mast to face of curb: 4'-3" minimum. Center of RR mast to edge of pavement (with shoulder): 6' minimum. Center of RR mast to edge of pavement (no shoulder): 8'-3" minimum. NOTE: BNSF prefers 5'-3", 7', and 9'-3" minimums, respectively.
- Q: Gate length: 28' or less typical, but railroad company may allow up to 32' under special circumstances.
- R: Stop line to first RR Crossing transverse line (bike lane): 50' typical.
- S: Stop line to GRADE CROSSING ADVANCE WARNING (W10-1) sign and adjacent RR Crossing pavement markings. See Table 1. See RCD(2) for other signs.

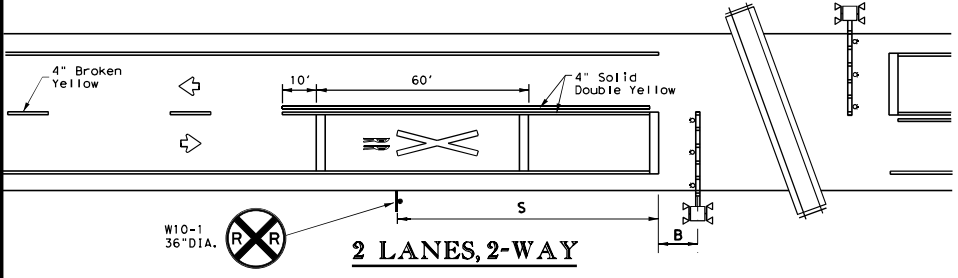

2 LANES, 2-WAY

TABLE 1	
Approach Speed (mph)	Desirable Placement (feet)
20	100
25	100
30	100
35	100
40	125
45	175
50	250
55	325
60	400
65	475
70	550
75	650

LEGEND	
	Sign
	Object Marker
	Traffic Flow
	Cantilever
	Gate Assembly
	Mast Flasher Pair

GENERAL NOTES

1. Medians and curbs must be non-traversable to qualify as a Quiet Zone Supplementary Safety Measure (SSM). Non-traversable curbs in Quiet Zones are 6" tall minimum and used on roadways where speed does not exceed 40 mph.
2. Raised pavement markers may be used to supplement striping. See PM(2) and PM(3) standard sheets.
3. Medians preferred whenever possible to prevent vehicles from driving around gates.
4. Longitudinal edge striping may be continued thru crossing as needed. Illumination may also be considered for nighttime visibility.
5. See SMD standard sheets for sign mounting details.
6. See the Standard Highway Sign Design for Texas (SHSD) manual for sign and pavement marking details.

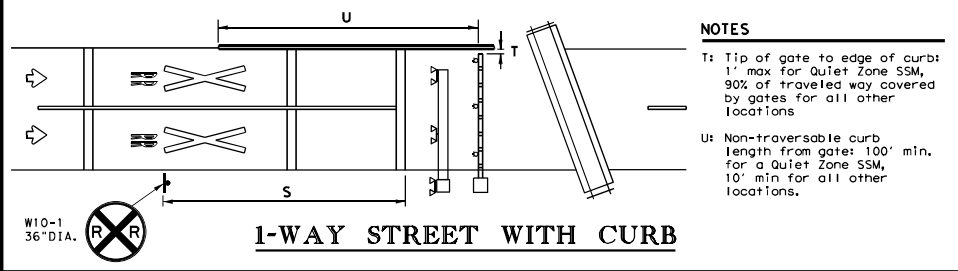

1-WAY STREET WITH CURB

- NOTES**
- T: Tip of gate to edge of curb: 1' max for Quiet Zone SSM, 90% of traveled way covered by gates for all other locations
 - U: Non-traversable curb length from gate: 100' min. for a Quiet Zone SSM, 10' min for all other locations.

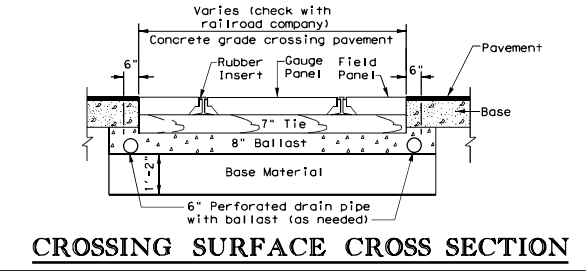

CROSSING SURFACE CROSS SECTION

Texas Department of Transportation
Traffic Operations Division Standard

RAILROAD CROSSING SIGNING, STRIPING, AND DEVICE PLACEMENT

RCD (1) - 16

FILE: rcd1-16.dgn	DW: Tx00T	CX: Tx00T	DW: Tx00T	CX: Tx00T
© Tx00T - FEBRUARY 2016	CONT: 001	JOB: 6379	SH 17A, ETC	MSH004
REVISONS:	DIST: 54	COUNTY: 001	SH 17A, ETC	
	DIST: 02	COUNTY: JOHNSON	SHEET NO. 15	

DISCLAIMER: This standard is governed by the "Texas Engineering Practice Act". No warranty of any kind is made by TxDOT for any purpose whatsoever. TxDOT assumes no responsibility for the conversion of this standard to other formats or for incorrect results or damages resulting from its use.

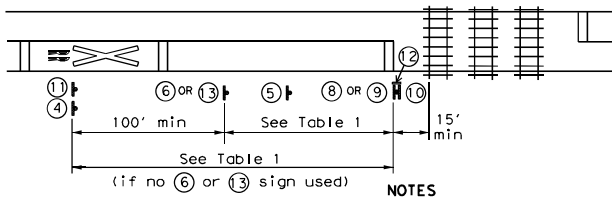

PASSIVE CROSSING

- NOTES**
1. Stop or yield sign may also be installed to the left of the crossbuck sign, rather than below it.
 2. A 2" white retroreflective strip shall be installed on front and back of crossbuck sign post.

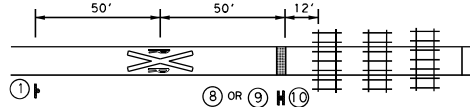

- NOTES**
1. A shared use pathway is considered a separate pathway crossing when more than 25' from traveled way of adjacent roadway.
 2. Detectable warning used at stop bar.
 3. Smaller sign sizes preferred than shown to the right on this sheet.

PATHWAY CROSSING

Approach Speed (mph)	Desirable Placement (feet)
20	100
25	100
30	100
35	100
40	125
45	175
50	250
55	325
60	400
65	475
70	550
75	650

GENERAL NOTES

1. Railroad company to provide active traffic control devices, CROSSBUCK (R15-1), NUMBER OF TRACKS Plaque (R15-2P) (if more than 1 track), and EMERGENCY NOTIFICATION (I-13) signs.
2. LOW GROUND CLEARANCE (W10-5) signs may be relocated further upstream of crossing to provide advance warning of alternate route.
3. GRADE CROSSING AND INTERSECTION ADVANCE WARNING (W10-2) signs may be modified to fit roadway geometry.
4. Table 1 placement distances may vary per Sect. 2C.05 of the T MUTCD.
5. See Table 1 to determine placement of STOP AHEAD (W3-1) and YIELD AHEAD (W3-2) signs unless shown otherwise.
6. DO NOT STOP ON TRACKS (R8-8) signs installed when potential for vehicles stopping on tracks is significant as determined by sealing engineer. Install so sign does not block view of RR mast.
7. See the Standard Highway Sign Design for Texas (SHSD) manual for sign and pavement marking details.

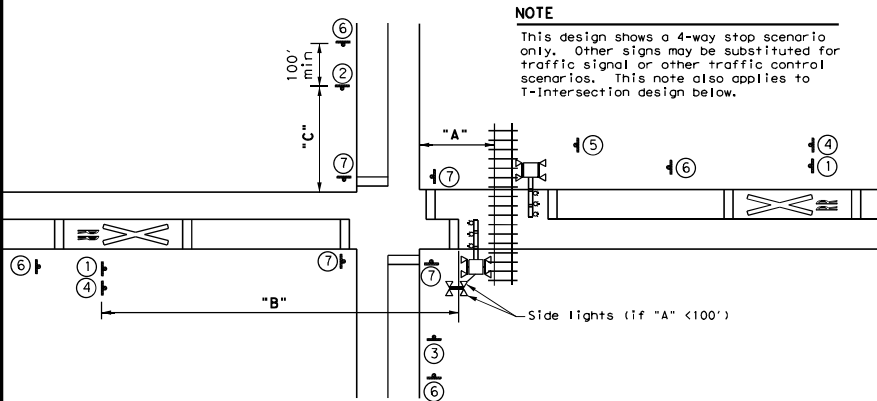

- NOTE**
- This design shows a 4-way stop scenario only. Other signs may be substituted for traffic signal or other traffic control scenarios. This note also applies to T-Intersection design below.

"A" < 100'	"A" ≥ 100'
See Table 1. Place pavement markings and signs on opposite side of intersection from rail if spacing from Table 1 would put markings within intersection.	See Table 1. Place pavement markings and signs between rail and intersection if spacing from Table 1 would put markings within intersection.
"B"	GRADE CROSSING AND INTERSECTION ADVANCE WARNING (W10-2, W10-3, W10-4) signs should only be installed if W10-1 sign is not between intersection and railroad crossing. If needed, see Table 1.
"C"	See Table 1.

GRADE CROSSING NEAR A PARALLEL STREET

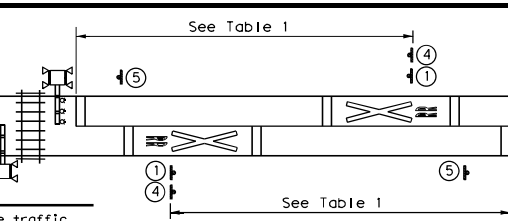
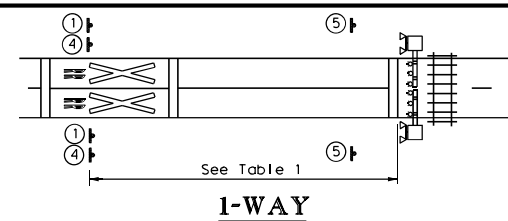
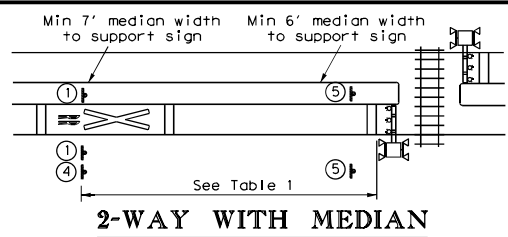
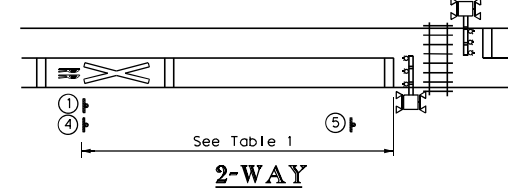

- NOTE**
- Separate active traffic control devices, railroad crossing pavement markings, and adjacent signs required when tracks are more than 100' apart.

2 ADJACENT CROSSINGS

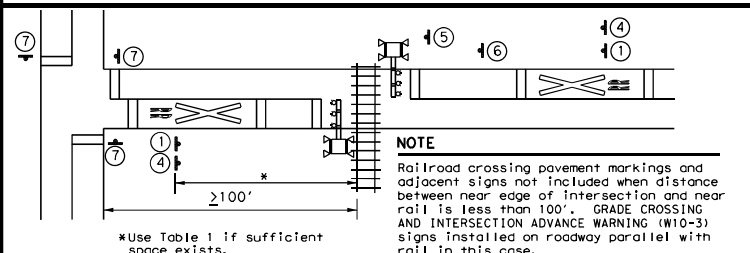

- NOTE**
- Railroad crossing pavement markings and adjacent signs not included when distance between near edge of intersection and near rail is less than 100'. GRADE CROSSING AND INTERSECTION ADVANCE WARNING (W10-3) signs installed on roadway parallel with rail in this case.

T-INTERSECTION

DATE: FILE:

SIGNS

** ① W10-1 36"X36"	** ② W10-2L 36"X36"	** ③ W10-2R 36"X36"	IF NEEDED ④ W10-5P 30"X24" LOW GROUND CLEARANCE
IF NEEDED ⑤ R8-8 24"X30"	IF NEEDED ⑥ W3-1 30"X30"	 R1-1 36"X36" R1-3P 18"X6"	RAIL CROSSING R15-1 48"X9" RAIL CROSSING R15-2P 27"X18" RAIL CROSSING R1-1 36"X36"
RAIL CROSSING R15-2P 27"X18" RAIL CROSSING R1-2 48"X48"X48"	RAIL CROSSING R15-1 48"X9" RAIL CROSSING R15-2P 27"X18"	 W10-1 36"X36" NO GATES OR LIGHTS W10-13P 30"X24"	REPORT EMERGENCY OR PROBLEM 800-555-5555 CROSSING 888-597-13 Sign may be placed perpend. to travel lanes.
IF NEEDED ⑬ W3-2 30"X30"	** Includes a NO TRAIN HORN Plaque (W10-9P) if crossing is in a Quiet Zone. LOW GROUND CLEARANCE Plaque (W10-5P) if needed is mounted below W10-2/W10-3/W10-4 signs.		
	NO TRAIN HORN W10-9P 30"X24"	LOW GROUND CLEARANCE W10-5P 30"X24"	

Texas Department of Transportation

RAILROAD CROSSING DETAILS

SIGNING & STRIPING

RCD (2) - 16

FILE: rcd2+16.dgn	DATE: TXDOT	CHK: TXDOT	DATE: TXDOT	CHK: TXDOT
© TXDOT FEBRUARY 2016	CONT: 54	SECT: 001	JOB: SH 174, ETC	HIGHWAY:
REVISTIONS	DATE: 02	BY: JOHNSON	COUNTY:	SHEET NO. 16

DISCLAIMER: of this standard is governed by the "Texas Engineering Practice Act". No warranty of any kind is made by TxDOT for any purpose whatsoever. TxDOT assumes no responsibility for the conversion of this standard to other formats or for incorrect results or damages resulting from its use.

DATE: FILE:

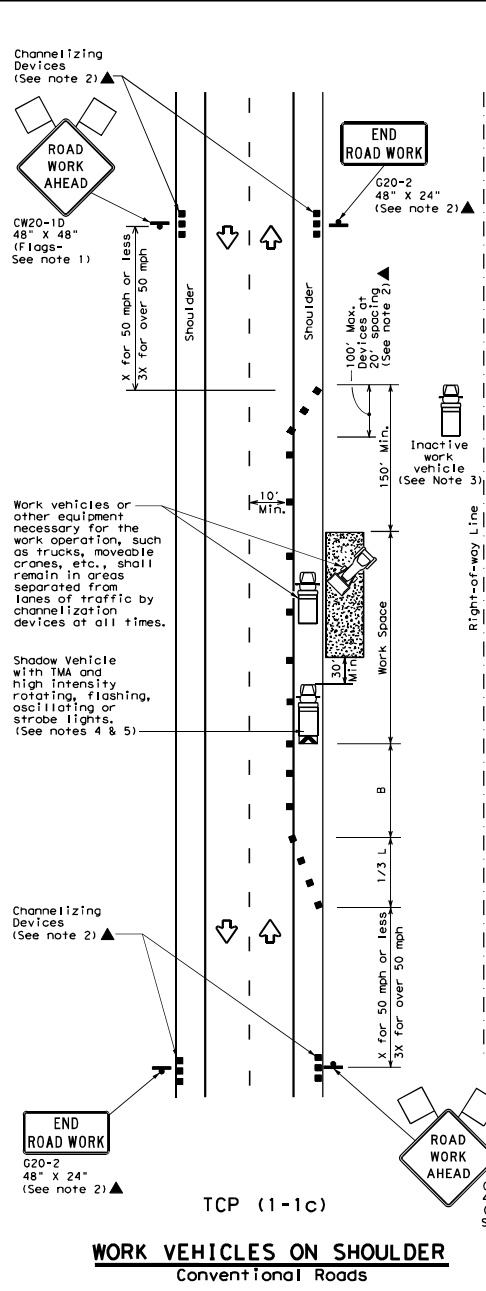
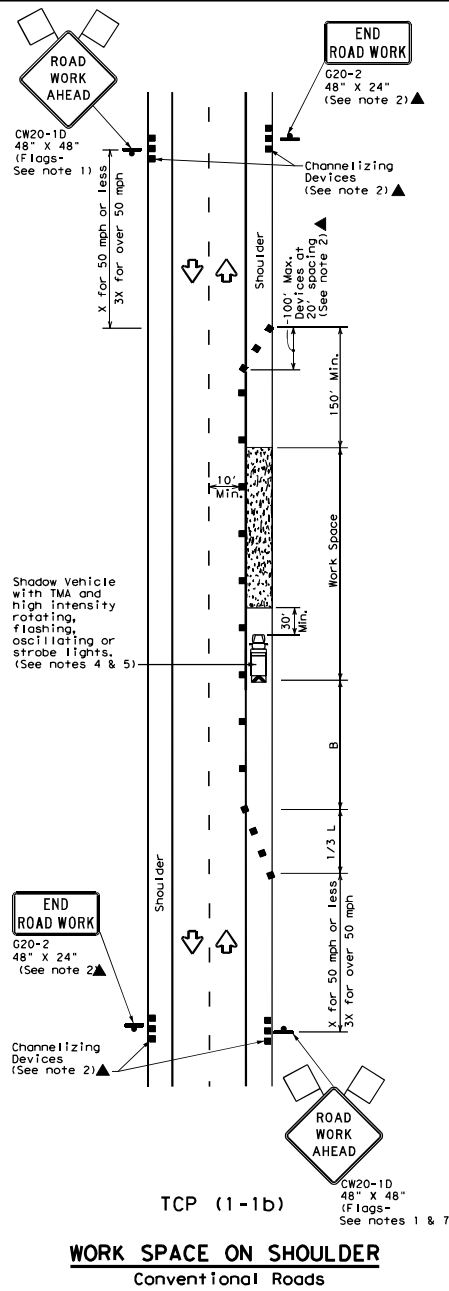
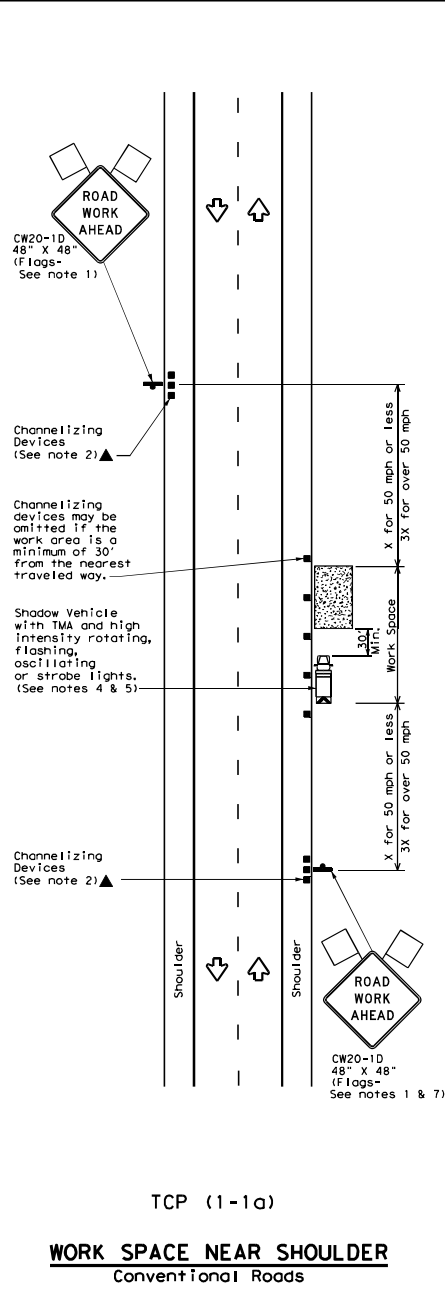

LEGEND			
	Type 3 Barricade		Channelizing Devices
	Heavy Work Vehicle		Truck Mounted Attenuator (TMA)
	Trailer Mounted Flashing Arrow Board		Portable Changeable Message Sign (PCMS)
	Sign		Traffic Flow
	Flag		Flagger

Posted Speed X	Formula	Minimum Desirable Taper Lengths			Suggested Maximum Spacing of Channelizing Devices		Minimum Sign Spacing "X" Distance	Suggested Longitudinal Buffer Space "B"
		10' Offset	11' Offset	12' Offset	On a Taper	On a Tangent		
30	$L = \frac{WS^2}{60}$	150'	165'	180'	30'	60'	120'	90'
35		205'	225'	245'	35'	70'	160'	120'
40		265'	295'	320'	40'	80'	240'	155'
45		450'	495'	540'	45'	90'	320'	195'
50		500'	550'	600'	50'	100'	400'	240'
55		550'	605'	660'	55'	110'	500'	295'
60		600'	660'	720'	60'	120'	600'	350'
65	650'	715'	780'	65'	130'	700'	410'	
70	700'	770'	840'	70'	140'	800'	475'	
75	750'	825'	900'	75'	150'	900'	540'	

* Conventional Roads Only
 ** Taper Lengths have been rounded off.
 L=Length of Taper (FT) W=Width of Offset(FT) S=Posted Speed(MPH)

TYPICAL USAGE				
MOBILE	SHORT DURATION	SHORT TERM STATIONARY	INTERMEDIATE TERM STATIONARY	LONG TERM STATIONARY
	✓	✓		

- GENERAL NOTES**
- Flags attached to signs where shown are REQUIRED.
 - All traffic control devices illustrated are REQUIRED, except those denoted with the triangle symbol may be omitted when stated elsewhere in the plans, or for routine maintenance work, when approved by the Engineer.
 - Inactive work vehicles or other equipment should be parked near the right-of-way line and not parked on the paved shoulder.
 - A Shadow Vehicle with a TMA should be used anytime it can be positioned 30 to 100 feet in advance of the area of crew exposure without adversely affecting the performance or quality of the work. If workers are no longer present but road or work conditions require the traffic control to remain in place, Type 3 Barricades or other channelizing devices may be substituted for the Shadow Vehicle and TMA.
 - Additional Shadow Vehicles with TMAs may be positioned off the paved surface, next to those shown in order to protect wider work spaces.
 - See TCP15-1 for shoulder work on divided highways, expressways and freeways.
 - CW21-5 "SHOULDER WORK" signs may be used in place of CW20-1D "ROAD WORK AHEAD" signs for shoulder work on conventional roadways.

Texas Department of Transportation
 Traffic Operations Division Standard

**TRAFFIC CONTROL PLAN
 CONVENTIONAL ROAD
 SHOULDER WORK**

TCP (1-1) - 18

FILE: tcp1-1-18.dgn	DWG:	CHK:	DWG:	CHK:
© TxDOT December 1985	CONT:	SECT:	JOB:	HIGHWAY:
2-94 4-98 REVISIONS	6379	54	001	SH 174, ETC
8-95 2-12	DIST:	COUNTY:	SHEET NO.:	
1-97 2-18		JOHNSON	17	

DISCLAIMER: This standard is governed by the "Texas Engineering Practice Act". No warranty of any kind is made by TxDOT for any purpose whatsoever. TxDOT assumes no responsibility for the conversion of this standard to other formats or for incorrect results or damages resulting from its use.

DATE: FILE:

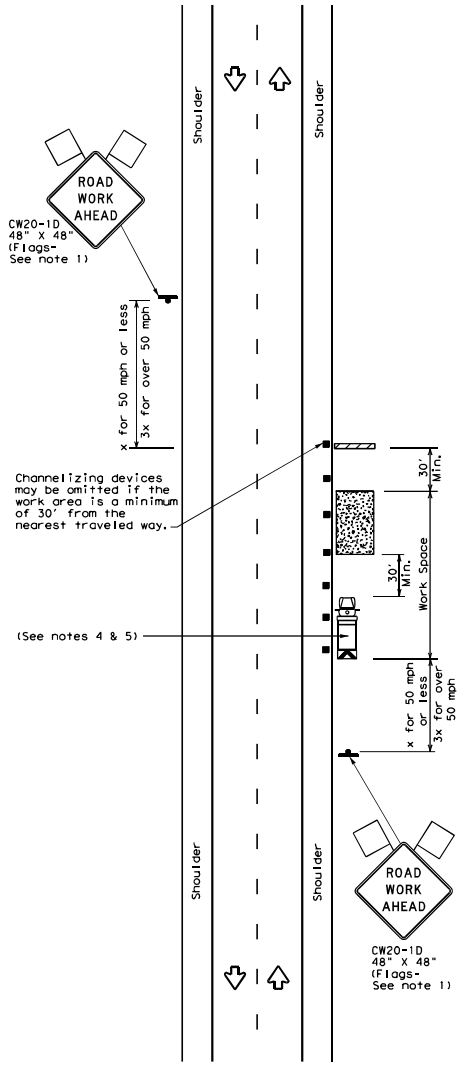

TCP (2-1a)

WORK SPACE NEAR SHOULDER
Conventional Roads

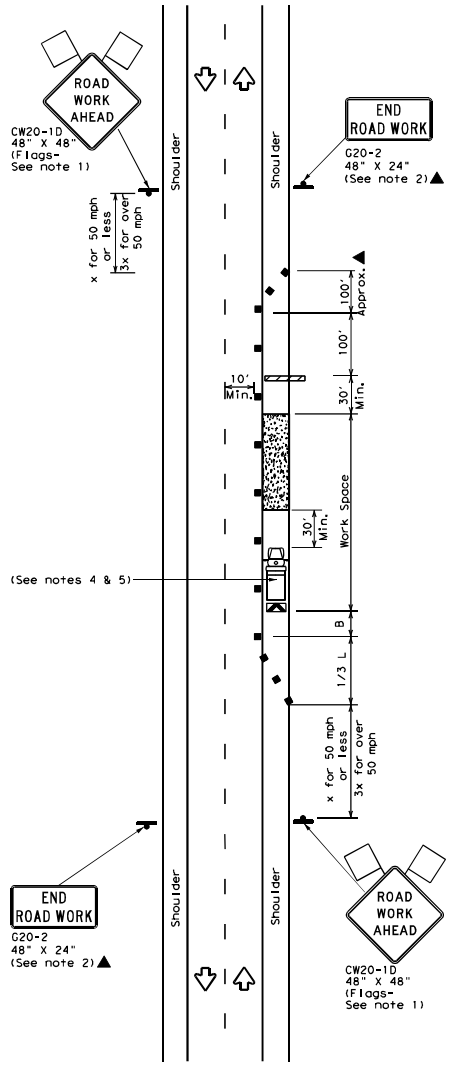

TCP (2-1b)

WORK SPACE ON SHOULDER
Conventional Roads

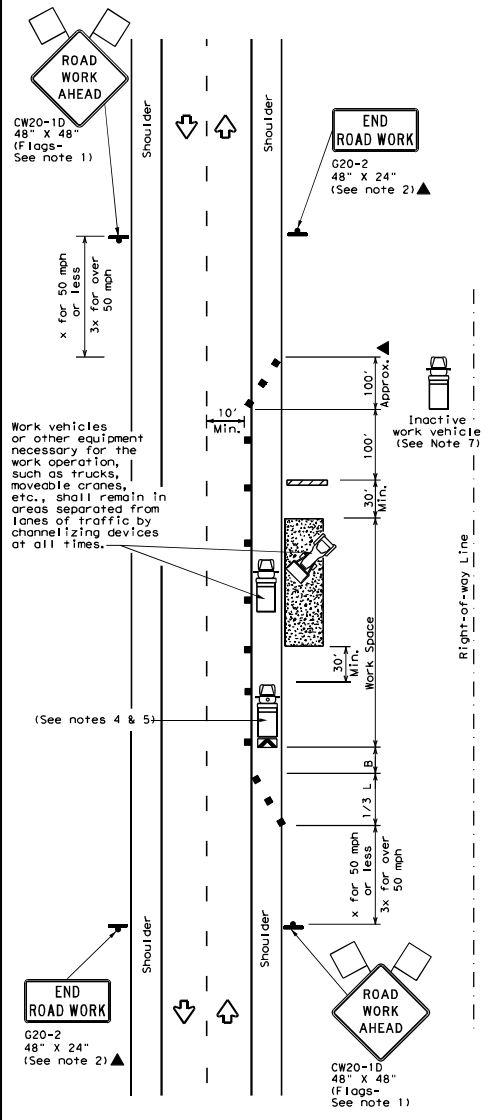

TCP (2-1c)

WORK VEHICLES ON SHOULDER
Conventional Roads

LEGEND			
	Type 3 Barricade		Channelizing Devices
	Heavy Work Vehicle		Truck Mounted Attenuator (TMA)
	Trailer Mounted Flashing Arrow Board		Portable Changeable Message Sign (PCMS)
	Sign		Traffic Flow
	Flag		Flagger

Posted Speed * L = WS/60	Formula	Minimum Desirable Taper Lengths			Suggested Maximum Spacing of Channelizing Devices		Minimum Sign Spacing "x" Distance	Suggested Longitudinal Buffer Space "B"
		10' Offset	11' Offset	12' Offset	On a Taper	On a Tangent		
30	L = WS/60	150'	165'	180'	30'	60'	120'	90'
35		205'	225'	245'	35'	70'	160'	120'
40		265'	295'	320'	40'	80'	240'	155'
45	L = WS	450'	495'	540'	45'	90'	320'	195'
50		500'	550'	600'	50'	100'	400'	240'
55		550'	605'	660'	55'	110'	500'	295'
60	L = WS	600'	660'	720'	60'	120'	600'	350'
65		650'	715'	780'	65'	130'	700'	410'
70		700'	770'	840'	70'	140'	800'	475'
75	L = WS	750'	825'	900'	75'	150'	900'	540'

* Conventional Roads Only
 ** Taper Lengths have been rounded off.
 L=Length of Taper (FT) W=Width of Offset (FT) S=Posted Speed (MPH)

TYPICAL USAGE				
MOBILE	SHORT DURATION	SHORT TERM STATIONARY	INTERMEDIATE TERM STATIONARY	LONG TERM STATIONARY
	✓		✓	✓

- GENERAL NOTES**
- Flags attached to signs where shown, are REQUIRED.
 - All traffic control devices illustrated are REQUIRED, except those denoted with the triangle symbol may be omitted when stated in the plans, or for routine maintenance work, when approved by the Engineer.
 - Stockpiled material should be placed a minimum of 30 feet from nearest traveled way.
 - Shadow Vehicle with TMA and high intensity rotating, flashing, oscillating or strobe lights. A Shadow Vehicle with a TMA should be used anytime it can be positioned 30 to 100 feet in advance of the area of crew exposure without adversely affecting the performance or quality of the work. If workers are no longer present but road or work conditions require the traffic control to remain in place, Type 3 Barricades or other channelizing devices may be substituted for the Shadow Vehicle and TMA.
 - Additional Shadow Vehicles with TMAs may be positioned off the paved surface, next to those shown in order to protect a wider work space.
 - See TCP(5-1) for shoulder work on divided highways, expressways and freeways.
 - Inactive work vehicles or other equipment should be parked near the right-of-way line and not parked on the paved shoulder.
 - CW21-5 "SHOULDER WORK" signs may be used in place of CW20-1D "ROAD WORK AHEAD" signs for shoulder work on conventional roadways.

Texas Department of Transportation
 Traffic Operations Division Standard

TRAFFIC CONTROL PLAN
CONVENTIONAL ROAD
SHOULDER WORK

TCP (2-1) - 18

FILE:	tcp2-1-18.dgn	DATE:	December 1985	BY:	CSK	JOB:	SH 174, ETC
REVISONS:		NO.		DATE			
1-97	2-18	6379	54	001			
8-95	2-12						
2-94	4-98						

DISCLAIMER: The use of this standard is governed by the "Texas Engineering Practice Act". No warranty of any kind is made by TxDOT for any purpose whatsoever. TxDOT assumes no responsibility for the conversion of this standard to other formats or for incorrect results or damages resulting from its use.

DATE: FILE:

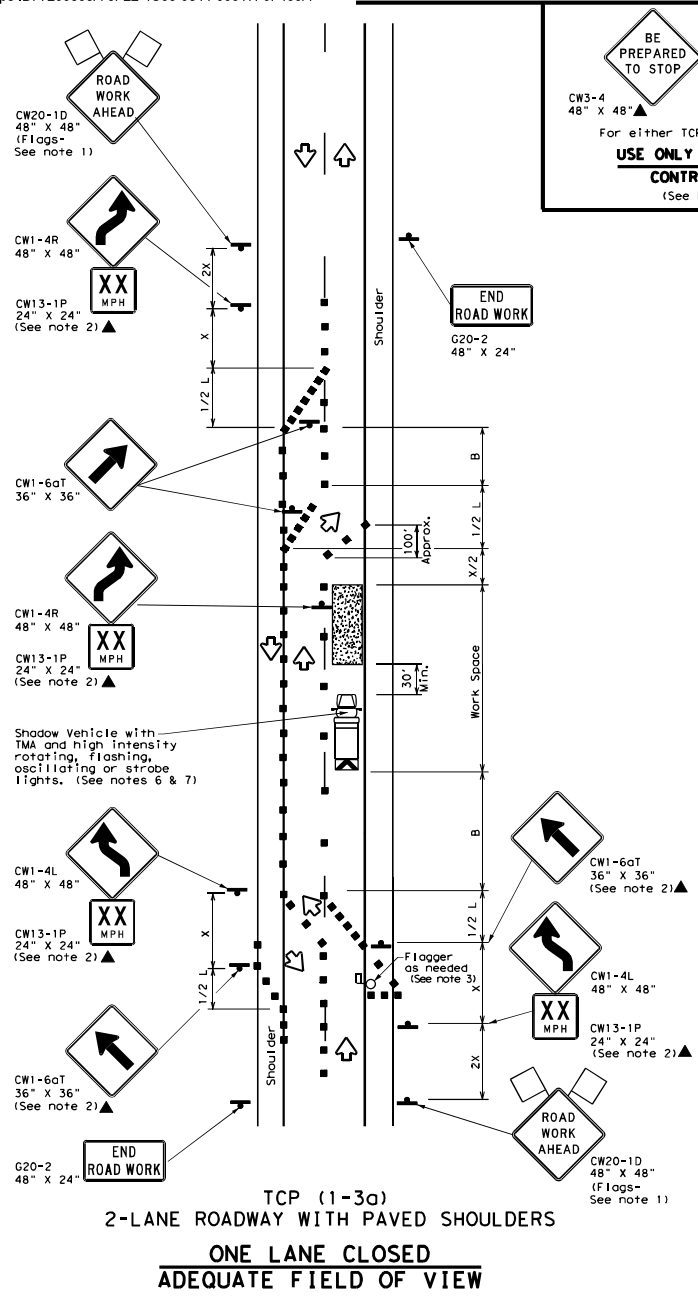

TCP (1-3a)
2-LANE ROADWAY WITH PAVED SHOULDERS
ONE LANE CLOSED
ADEQUATE FIELD OF VIEW

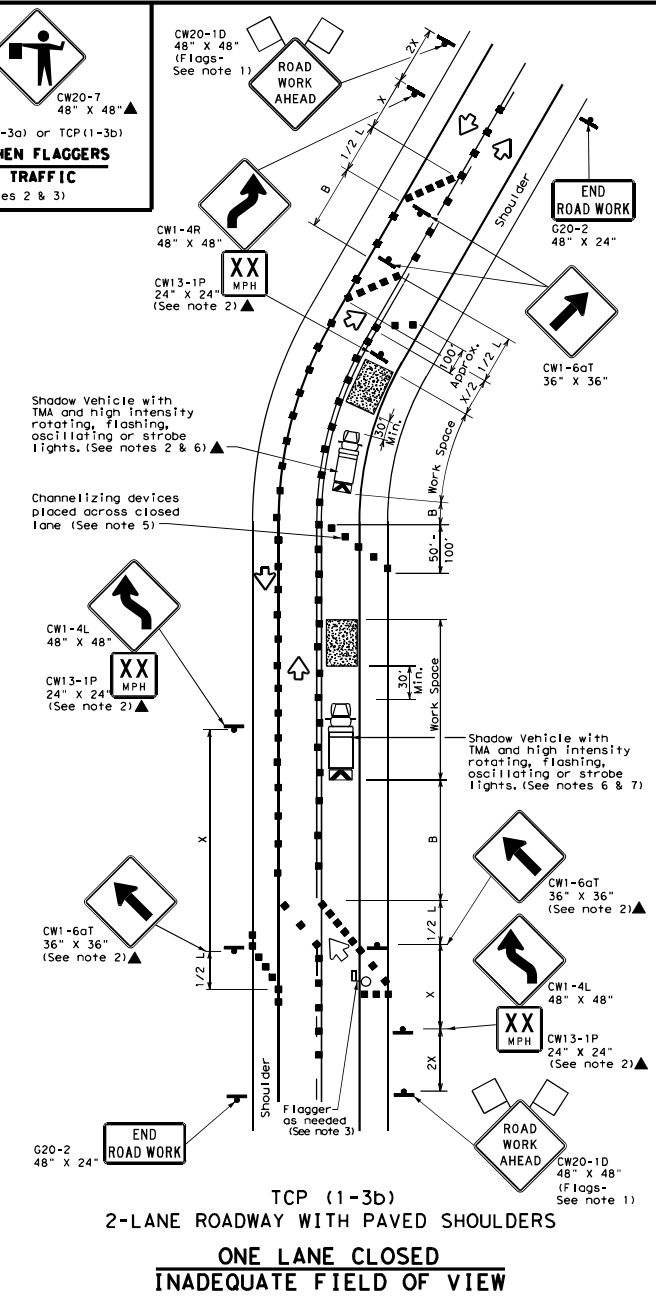

TCP (1-3b)
2-LANE ROADWAY WITH PAVED SHOULDERS
ONE LANE CLOSED
INADEQUATE FIELD OF VIEW

LEGEND			
	Type 3 Barricade		Channelizing Devices
	Heavy Work Vehicle		Truck Mounted Attenuator (TMA)
	Trailer Mounted Flashing Arrow Board		Portable Changeable Message Sign (PCMS)
	Sign		Traffic Flow
	Flag		Flagger

Posted Speed *	Formula	Minimum Desirable Taper Lengths **			Suggested Maximum Spacing of Channelizing Devices		Minimum Sign Spacing * Distance	Suggested Longitudinal Buffer Spacing "B"
		10' Offset	11' Offset	12' Offset	On a Taper	On a Tangent		
30	L = WS ² / 60	150'	165'	180'	30'	60'	120'	90'
35		205'	225'	245'	35'	70'	160'	120'
40		265'	295'	320'	40'	80'	240'	155'
45	L + WS	450'	495'	540'	45'	90'	320'	195'
50		500'	550'	600'	50'	100'	400'	240'
55		550'	605'	660'	55'	110'	500'	295'
60		600'	660'	720'	60'	120'	600'	350'
65		650'	715'	780'	65'	130'	700'	410'
70		700'	770'	840'	70'	140'	800'	475'
75		750'	825'	900'	75'	150'	900'	540'

* Conventional Roads Only
** Taper lengths have been rounded off.
L=Length of Taper (FT) W=Width of Offset (FT) S=Posted Speed (MPH)

TYPICAL USAGE				
MOBILE	SHORT DURATION	SHORT TERM STATIONARY	INTERMEDIATE TERM STATIONARY	LONG TERM STATIONARY
	✓	✓		

- GENERAL NOTES**
- Flags attached to signs where shown are REQUIRED.
 - All traffic control devices illustrated are REQUIRED, except those denoted with the triangle symbol may be omitted when stated elsewhere in the plans, or for routine maintenance work, when approved by the Engineer.
 - Flagger control should NOT be used unless roadway conditions or heavy traffic volume require additional emphasis to safely control traffic. Additional flaggers may be positioned in advance of traffic queues to alert traffic to reduce speed.
 - DO NOT PASS, PASS WITH CARE and construction regulatory speed zone signs may be installed downstream of the ROAD WORK AHEAD signs.
 - When the work zone is made up of several work spaces, channelizing devices should be placed laterally across the closed lane to re-emphasize closure. Laterally placed channelizing devices should be repeated every 500 to 1000 feet in urban areas and every 1/4 to 1/2 mile in rural areas.
 - A Shadow Vehicle with a TMA should be used anytime it can be positioned 30 to 100 feet in advance of the area of crew exposure without adversely affecting the performance or quality of the work. If workers are no longer present but road or work conditions require the traffic control to remain in place, Type 3 Barricades or other channelizing devices may be substituted for the Shadow Vehicle and TMA.
 - Additional Shadow Vehicles with TMAs may be positioned off the paved surface, next to those shown in order to protect wider work spaces.
 - Where traffic is directed over a yellow centerline, channelizing devices which separate two-way traffic should be spaced on tapers at 20', or 15' if posted speed are 35 mph or slower, and for tangent sections, at 1/2S where S is the speed in mph. This tighter device spacing is intended for the area of conflicting markings not the entire work zone.

Texas Department of Transportation
Traffic Operations Division Standard

**TRAFFIC CONTROL PLAN
TRAFFIC SHIFTS ON
TWO LANE ROADS
TCP (1-3) - 18**

FILES: tcp1-3-18.dgn	DATE: December 1985	CHK: []	DRW: []	CHK: []
① TxDOT	REVISED: 2-94 4-98	CONT: 6379	SECT: 54	JOB: 001
	REVISED: 8-95 2-12	DIST: []	COUNTY: []	SH: 174, E.T.C.
	REVISED: 1-97 2-18	DIST: []	COUNTY: []	SHEET NO. []
		02	JOHNSON	19

DISCLAIMER: This standard is governed by the "Texas Engineering Practice Act". No warranty of any kind is made by TxDOT for any purpose whatsoever. TxDOT assumes no responsibility for the conversion of this standard to other formats or for incorrect results or damages resulting from its use.

DATE: FILE:

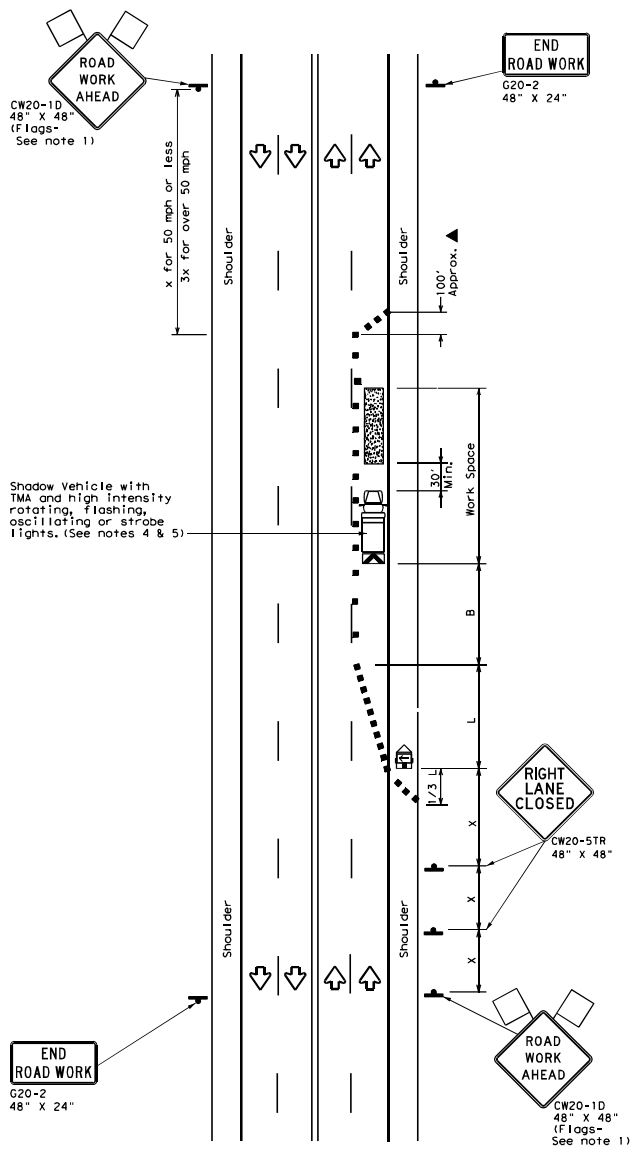

TCP (1-4a)
ONE LANE CLOSED

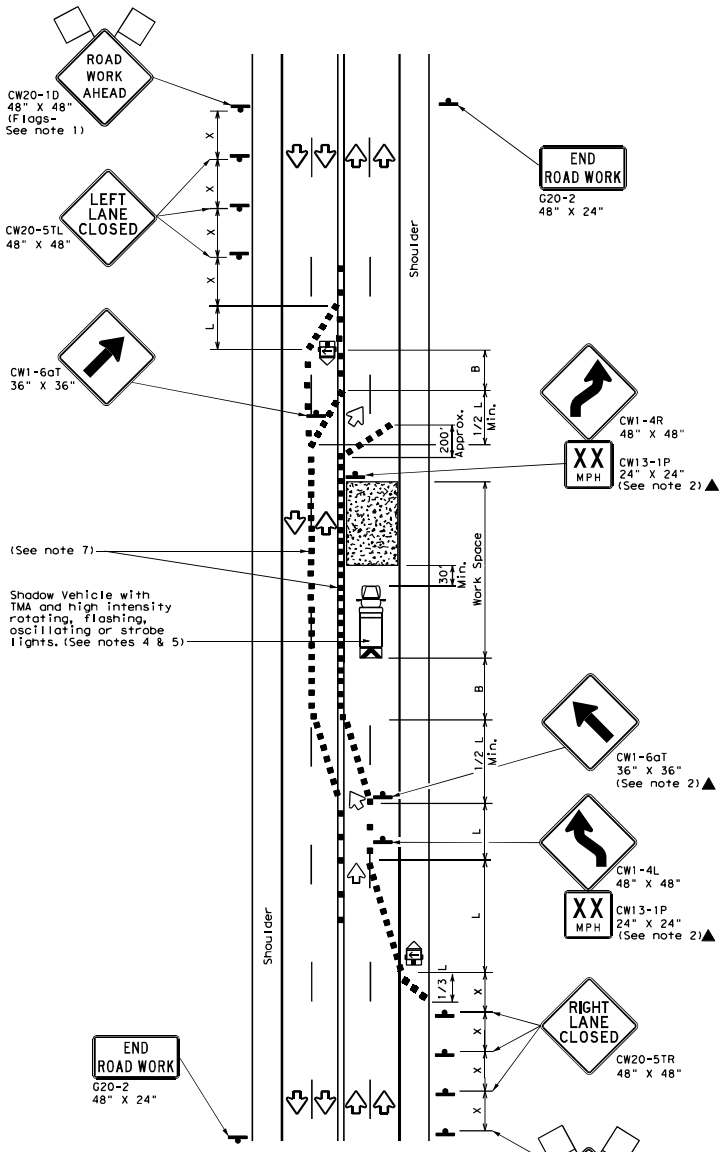

TCP (1-4b)
TWO LANES CLOSED

LEGEND			
	Type 3 Barricade		Channelizing Devices
	Heavy Work Vehicle		Truck Mounted Attenuator (TMA)
	Trailer Mounted Flashing Arrow Board		Portable Changeable Message Sign (PCMS)
	Sign		Traffic Flow
	Flag		Flagger

Posted Speed *	Formula	Minimum Desirable Taper Lengths **			Suggested Maximum Spacing of Channelizing Devices		Minimum Sign Spacing Distance	Suggested Longitudinal Buffer Space B'
		10' Offset	11' Offset	12' Offset	On a Taper	On a Tangent		
30	L = WS ² / 60	150'	165'	180'	30'	60'	120'	90'
35		205'	225'	245'	35'	70'	160'	120'
40		265'	295'	320'	40'	80'	240'	155'
45	L = WS	450'	495'	540'	45'	90'	320'	195'
50		500'	550'	600'	50'	100'	400'	240'
55		550'	605'	660'	55'	110'	500'	295'
60		600'	660'	720'	60'	120'	600'	350'
65		650'	715'	780'	65'	130'	700'	410'
70	700'	770'	840'	70'	140'	800'	475'	
75	750'	825'	900'	75'	150'	900'	540'	

* Conventional Roads Only
 ** Taper lengths have been rounded off.
 L=Length of Taper (FT) W=Width of Offset(FT) S=Posted Speed(MPH)

TYPICAL USAGE				
MOBILE	SHORT DURATION	SHORT TERM STATIONARY	INTERMEDIATE TERM STATIONARY	LONG TERM STATIONARY
	✓	✓		

- GENERAL NOTES**
- Flags attached to signs where shown are REQUIRED.
 - All traffic control devices illustrated are REQUIRED, except those denoted with the triangle symbol may be omitted when stored elsewhere in the plans, or for routine maintenance work, when approved by the Engineer.
 - The CW20-1D "ROAD WORK AHEAD" sign may be repeated if the visibility of the work zone is less than 1500 feet.
 - A Shadow Vehicle with a TMA should be used anytime it can be positioned 30 to 100 feet in advance of the area of crew exposure without adversely affecting the performance or quality of the work. If workers are no longer present but road or work conditions require the traffic control to remain in place, Type 3 Barricades or other channelizing devices may be substituted for the Shadow Vehicle and TMA.
 - Additional Shadow Vehicles with TMAs may be positioned off the paved surface, next to those shown in order to protect wider work spaces.
- TCP (1-4a)**
- If this TCP is used for a left lane closure, CW20-5TL "LEFT LANE CLOSED" signs shall be used and channelizing devices shall be placed on the centerline where needed to protect the work space from opposing traffic with the arrow panel placed in the closed lane near the end of the merging taper.
- TCP (1-4b)**
- Where traffic is directed over a yellow centerline, channelizing devices which separate two-way traffic should be spaced on tapers of 20' or 15' if posted speeds are 35 mph or slower, and for tangent sections, at 1/2S where S is the speed in mph. This tighter device spacing is intended for the areas of conflicting markings, not the entire work zone.

Traffic Operations Division Standard

TRAFFIC CONTROL PLAN LANE CLOSURES ON MULTILANE CONVENTIONAL ROADS

TCP (1-4) - 18

FILE:	tcp1-4-18.dgn	DATE:	01/15/02	BY:	JOHNSON
PROJECT:	December 1985	CONTRACT:	637954	JOB:	001
REVISIONS:	2-94 4-98	DESIGNER:	JOHNSON	SHEET NO.:	174, ETC
	8-99 2-12	DATE:	02	DESIGNER:	JOHNSON
	1-01 2-18				20

DISCLAIMER: The use of this standard is governed by the "Texas Engineering Practice Act". No warranty of any kind is made by TxDOT for the use of this standard or for incorrect results or damages resulting from its use.

DATE:
FILE:

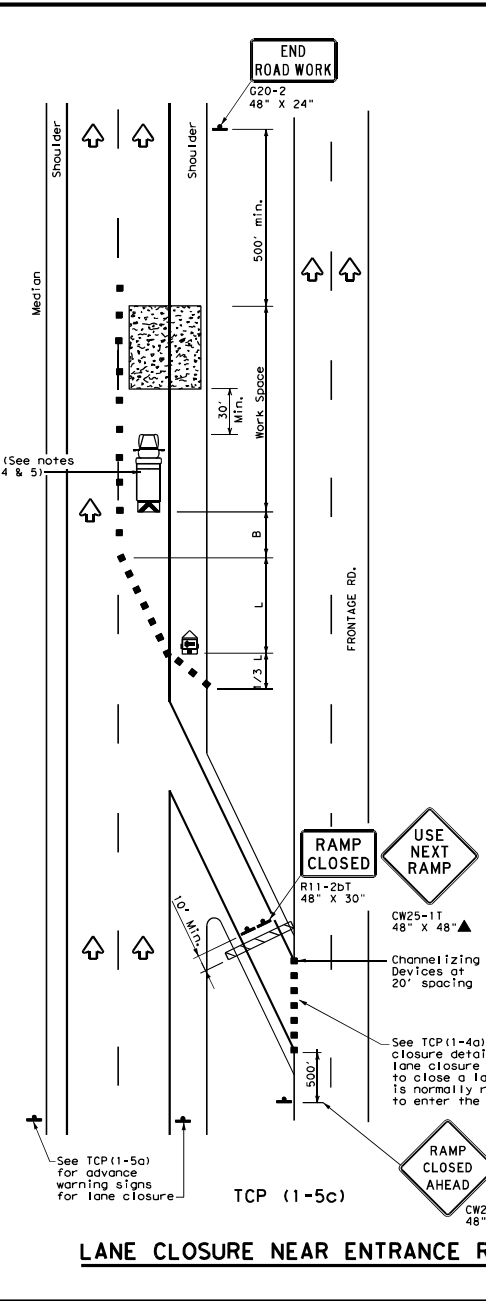
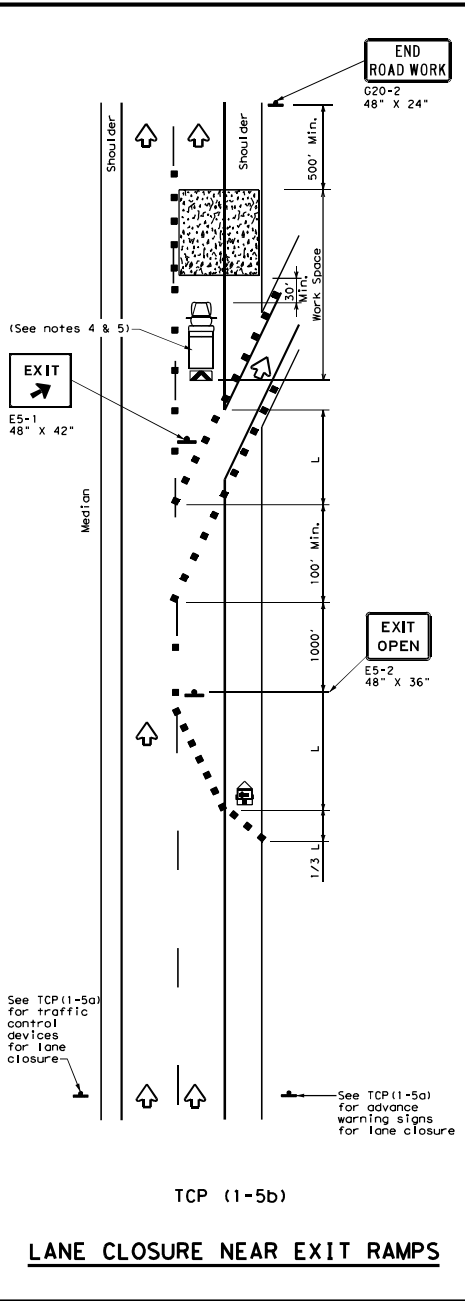
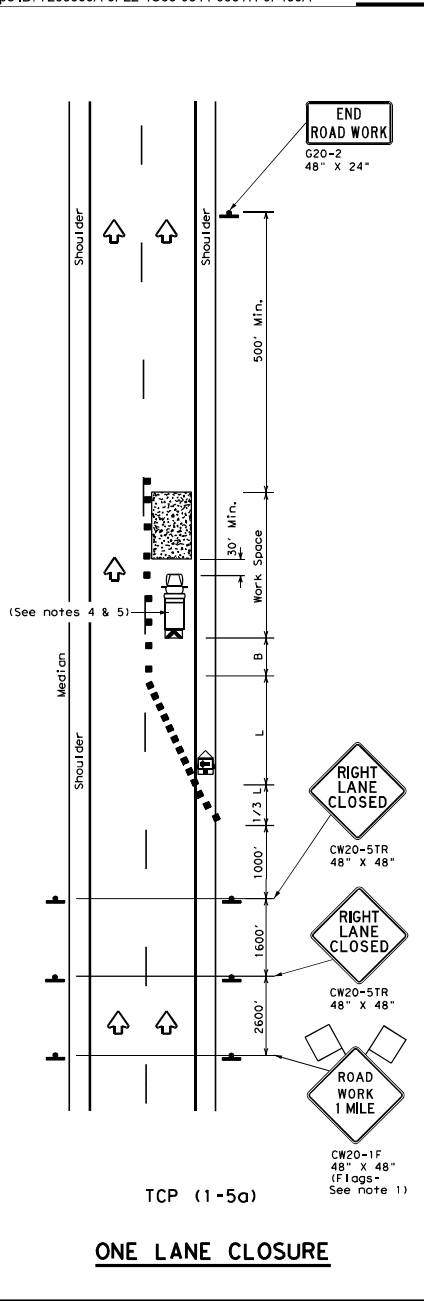

LEGEND			
	Type 3 Barricade		Channelizing Devices
	Heavy Work Vehicle		Truck Mounted Attenuator (TMA)
	Trailer Mounted Flashing Arrow Board		Portable Changeable Message Sign (PCMS)
	Sign		Traffic Flow
	Flag		Flagger

Posted Speed * 30 35 40 45 50 55 60 65 70 75	Formula L = $\frac{W \cdot C^2}{60}$ L = WS	Minimum Desirable Taper Lengths **			Suggested Maximum Spacing of Channelizing Devices		Minimum Sign Spacing Distance	Suggested Longitudinal Buffer Space "B"
		10' Offset	11' Offset	12' Offset	On a Taper	On a Tangent		
30		150'	165'	180'	30'	60'	120'	90'
35		205'	225'	245'	35'	70'	160'	120'
40		265'	295'	320'	40'	80'	240'	155'
45		450'	495'	540'	45'	90'	320'	195'
50		500'	550'	600'	50'	100'	400'	240'
55		550'	605'	660'	55'	110'	500'	295'
60		600'	660'	720'	60'	120'	600'	350'
65		650'	715'	780'	65'	130'	700'	410'
70		700'	770'	840'	70'	140'	800'	475'
75		750'	825'	900'	75'	150'	900'	540'

* Conventional Roads Only
** Taper lengths have been rounded off.
L=Length of Taper (FT) W=Width of Offset (FT) S=Posted Speed (MPH)

TYPICAL USAGE				
MOBILE	SHORT DURATION	SHORT TERM STATIONARY	INTERMEDIATE TERM STATIONARY	LONG TERM STATIONARY
		✓		

- GENERAL NOTES**
- Flags attached to signs where shown, are REQUIRED.
 - All traffic control devices illustrated are REQUIRED, except those denoted with the triangle symbol may be omitted when stated elsewhere in the plans, or for routine maintenance work, when approved by the Engineer.
 - Channelizing devices used to close lanes may be supplemented with the Chevron Alignment Sign placed on every other channelizing device. Chevrons may be attached to plastic drums as per BC Standards.
 - Shadow Vehicle with TMA and high intensity rotating, flashing, oscillating or strobe lights. A Shadow Vehicle with a TMA should be used anytime it can be positioned 30 to 100 feet in advance of the area of crew exposure without adversely affecting the performance or quality of the work. If workers are no longer present but road or work conditions require the traffic control to remain in place, Type 3 Barricades or other channelizing devices may be substituted for the Shadow Vehicle and TMA.
 - Additional Shadow Vehicles with TMAs may be positioned in each closed lane, on the shoulder or off the paved surface, next to those shown in order to protect a wider work space.

Texas Department of Transportation
Traffic Operations Division Standard

**TRAFFIC CONTROL PLAN
LANE CLOSURES FOR
DIVIDED HIGHWAYS**

TCP (1-5) - 18

FILE:	tcp1-5-18.dgn	DATE:	02/11/12	BY:	SH
© 1x2007	February 2012	REV:	001	JOB:	SH 174, ETC
2-18	REVISIONS	6/3/09	5/4	COUNTY:	
		02		JOHNSON	SHEET NO. 21

DISCLAIMER: This standard is governed by the "Texas Engineering Practice Act". No warranty of any kind is made by TxDOT for any purpose whatsoever. TxDOT assumes no responsibility for the conversion of this standard to other formats or for incorrect results or damages resulting from its use.

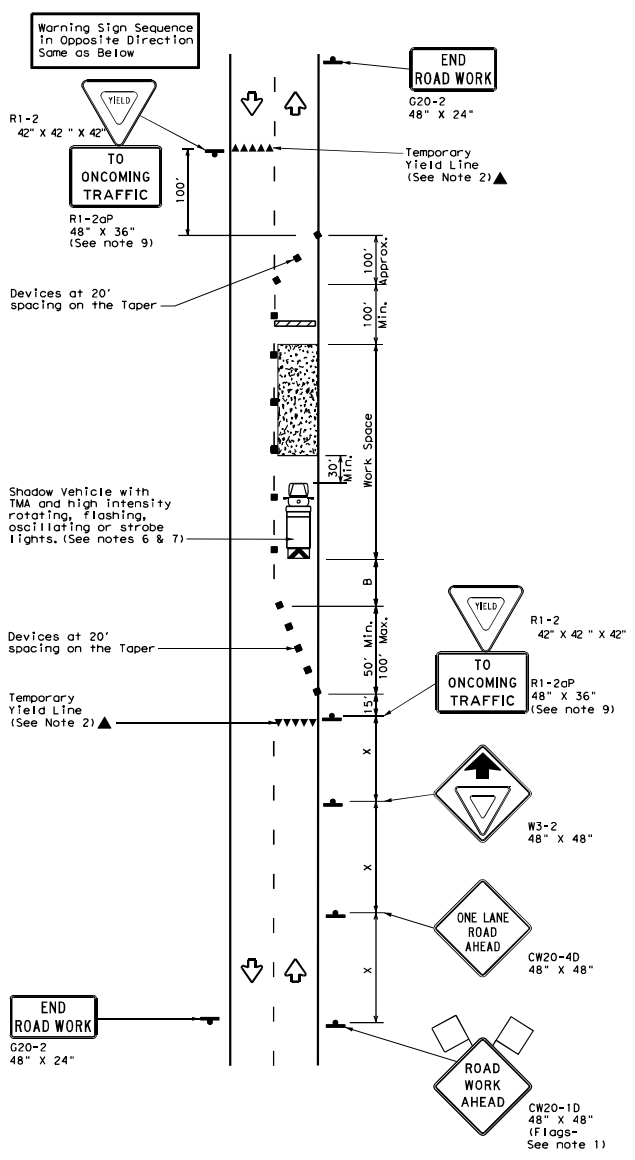

TCP (2-2a)
 2-LANE ROADWAY WITHOUT PAVED SHOULDERS
ONE LANE TWO-WAY
CONTROL WITH YIELD SIGNS
 (Less than 2000 ADT - See Note 9)

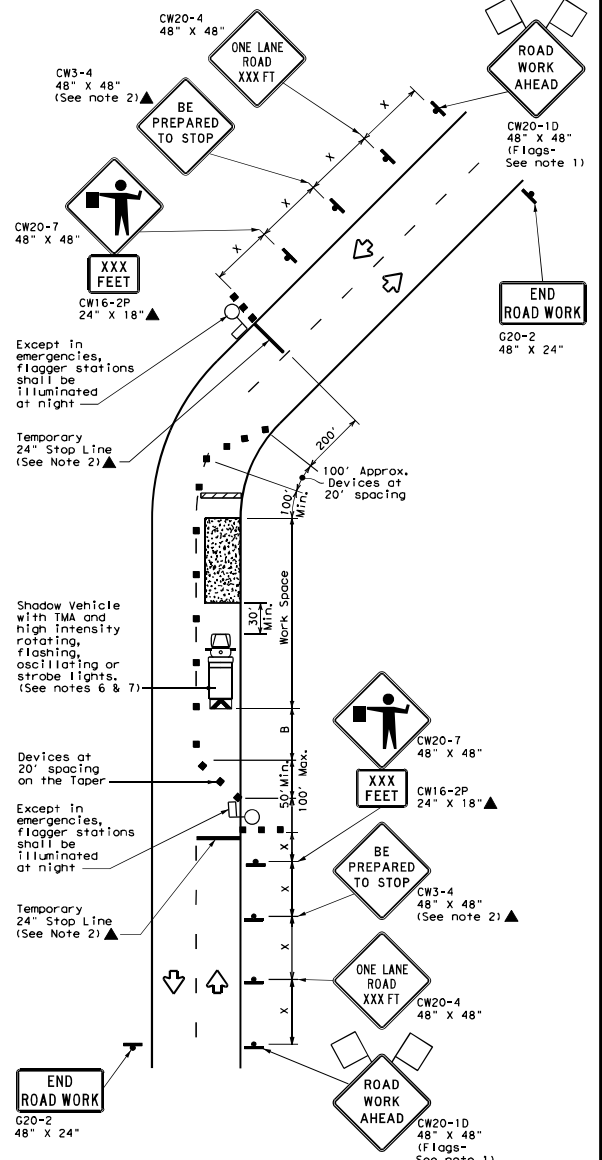

TCP (2-2b)
 2-LANE ROADWAY WITHOUT PAVED SHOULDERS
ONE LANE TWO-WAY
CONTROL WITH FLAGGERS

LEGEND

	Type 3 Barricade		Channelizing Devices
	Heavy Work Vehicle		Truck Mounted Attenuator (TMA)
	Trailer Mounted Flashing Arrow Board		Portable Changeable Message Sign (PCMS)
	Sign		Traffic Flow
	Flag		Flagger

Posted Speed * X	Formula	Minimum Desirable Taper Lengths **			Suggested Maximum Spacing of Channelizing Devices		Minimum Sign Spacing * X Distance	Suggested Longitudinal Buffer Space "B"	Stopping Sight Distance
		10' Offset	11' Offset	12' Offset	On a Taper	On a Tangent			
30	L = WS ² / 60	150'	165'	180'	30'	60'	120'	90'	200'
35		205'	225'	245'	35'	70'	160'	120'	250'
40		265'	295'	320'	40'	80'	240'	155'	305'
45	L = WS	450'	495'	540'	45'	90'	320'	195'	360'
50		500'	550'	600'	50'	100'	400'	240'	425'
55		550'	605'	660'	55'	110'	500'	295'	495'
60		600'	660'	720'	60'	120'	600'	350'	570'
65		650'	715'	780'	65'	130'	700'	410'	645'
70	700'	770'	840'	70'	140'	800'	475'	730'	
75	750'	825'	900'	75'	150'	900'	540'	820'	

* Conventional Roads Only
 ** Taper lengths have been rounded off.
 L-Length of Taper (FT) W-Width of Offset (FT) S-Posted Speed (MPH)

TYPICAL USAGE

MOBILE	SHORT DURATION	SHORT TERM STATIONARY	INTERMEDIATE TERM STATIONARY	LONG TERM STATIONARY
	✓	✓	✓	

GENERAL NOTES

- Flags attached to signs where shown, are REQUIRED.
 - All traffic control devices illustrated are REQUIRED, except those denoted with the triangle symbol may be omitted when stated elsewhere in the plans, or for routine maintenance work, when approved by the Engineer.
 - The CW3-4 "BE PREPARED TO STOP" sign may be installed after the CW20-4 "ONE LANE ROAD XXX FT" sign, but proper sign spacing shall be maintained.
 - Flaggers should use two-way radios or other methods of communication to control traffic.
 - Length of work space should be based on the ability of flaggers to communicate.
 - A Shadow Vehicle with a TMA should be used anytime it can be positioned 30 to 100 feet in advance of the area of crew exposure without adversely affecting the performance or quality of the work. If workers are no longer present but road or work conditions require the traffic control to remain in place, Type 3 Barricades or other channelizing devices may be substituted for the Shadow Vehicle and TMA.
 - Additional Shadow Vehicles with TMAs may be positioned off the paved surface, next to those shown in order to protect a wider work space.
- TCP (2-2a)**
- The R1-2 "YIELD" sign traffic control may be used on projects with approaches that have adequate sight distance. For projects in urban areas, work space should be no longer than one half city block. In rural areas, roadways with less than 2000 ADT, work space should be no longer than 400 feet.
 - The R1-2aP "YIELD TO ONCOMING TRAFFIC" sign shall be placed on a support of a 7 foot minimum mounting height.
- TCP (2-2b)**
- Channelizing devices on the center line may be omitted when a pilot car is leading traffic and approved by the Engineer.
 - If the work space is located near a horizontal or vertical curve, the buffer distances should be increased in order to maintain stopping sight distance to the flagger and a queue of stopped vehicles. (See table above).
 - Flaggers should use 24" STOP/SLOW paddles to control traffic. Flags should be limited to emergency situations.

Texas Department of Transportation Traffic Operations Division Standard

TRAFFIC CONTROL PLAN
ONE-LANE TWO-WAY
TRAFFIC CONTROL

TCP (2-2) - 18

FILE#	tcp2-2-18.dgn	DATE	08/11/98	BY	JKS	CHKD	JKS	DATE	08/11/98
REV#	01	DATE	08/11/98	BY	JKS	CHKD	JKS	DATE	08/11/98
REV#	02	DATE	08/11/98	BY	JKS	CHKD	JKS	DATE	08/11/98
REV#	03	DATE	08/11/98	BY	JKS	CHKD	JKS	DATE	08/11/98
REV#	04	DATE	08/11/98	BY	JKS	CHKD	JKS	DATE	08/11/98

DATE: FILE:

DISCLAIMER: This standard is governed by the "Texas Engineering Practice Act". No warranty of any kind is made by TxDOT for any purpose whatsoever. TxDOT assumes no responsibility for the conversion of this standard to other formats or for incorrect results or damages resulting from its use.

DATE: FILES:

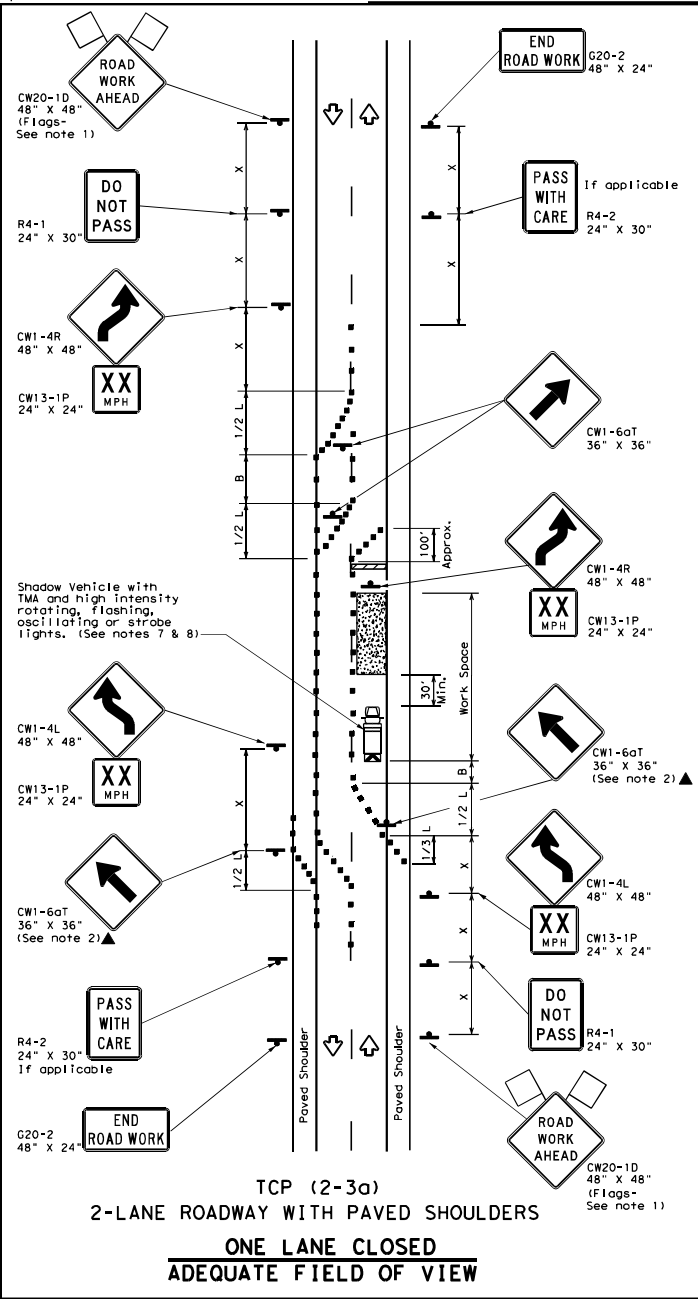

TCP (2-3a)
2-LANE ROADWAY WITH PAVED SHOULDERS
ONE LANE CLOSED
ADEQUATE FIELD OF VIEW

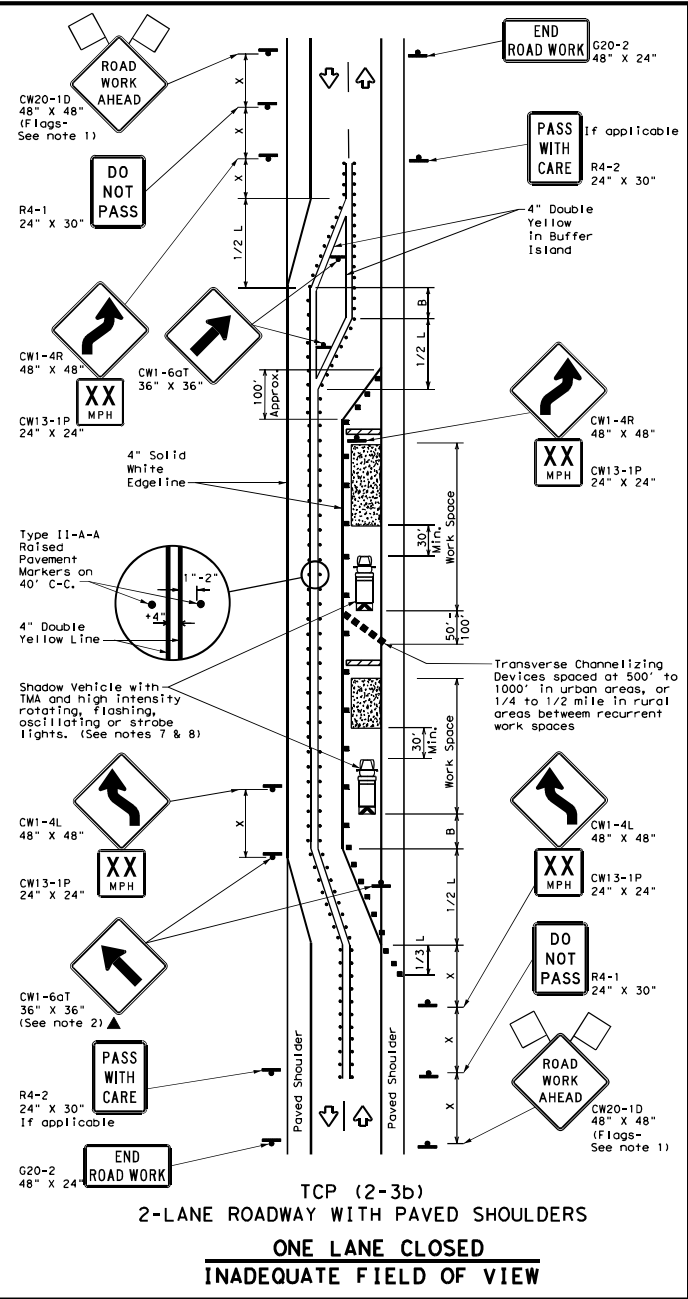

TCP (2-3b)
2-LANE ROADWAY WITH PAVED SHOULDERS
ONE LANE CLOSED
INADEQUATE FIELD OF VIEW

LEGEND			
	Type 3 Barricade		Channelizing Devices
	Heavy Work Vehicle		Truck Mounted Attenuator (TMA)
	Trailer Mounted Flashing Arrow Board		Raised Pavement Markers Ty II-AA
	Sign		Traffic Flow
	Flag		Flagger

Posted Speed *	Formula	Minimum Desirable Taper Lengths **			Suggested Maximum Spacing of Channelizing Devices		Minimum Sign Spacing Distance	Suggested Longitudinal Buffer Space "B"
		10' Offset	11' Offset	12' Offset	On a Taper	On a Tangent		
30	L = W * S / 60	150'	165'	180'	30'	60'	120'	90'
35		205'	225'	245'	35'	70'	160'	120'
40		265'	295'	320'	40'	80'	240'	155'
45	L = W * S	450'	495'	540'	45'	90'	320'	195'
50		500'	550'	600'	50'	100'	400'	240'
55		550'	605'	660'	55'	110'	500'	295'
60		600'	660'	720'	60'	120'	600'	350'
65		650'	715'	780'	65'	130'	700'	410'
70		700'	770'	840'	70'	140'	800'	475'
75		750'	825'	900'	75'	150'	900'	540'

* Conventional Roads Only
 ** Taper lengths have been rounded off.
 L-Length of Taper (FT) W-Width of Offset (FT) S-Posted Speed (MPH)

TYPICAL USAGE				
MOBILE	SHORT DURATION	SHORT TERM STATIONARY	INTERMEDIATE TERM STATIONARY	LONG TERM STATIONARY
				TCP (2-3b) ONLY

- GENERAL NOTES**
- Flags attached to signs where shown, are REQUIRED.
 - All traffic control devices illustrated are REQUIRED, except those denoted with the triangle symbol may be omitted when stated elsewhere in the plans, or for routine maintenance work, when approved by the Engineer.
 - When work space will be in place less than three days existing pavement markings may remain in place. Channelizing devices shall be used to separate traffic.
 - Flagger control should NOT be used unless roadway conditions or heavy traffic volume require additional emphasis to safely control traffic. Flagger should be positioned at end of traffic queue.
 - The R4-1 "DO NOT PASS," R4-2 "PASS WITH CARE" and construction regulatory speed zone signs may be installed within CW20-1D "ROAD WORK AHEAD" signs. Proper spacing of signs shall be maintained.
 - Conflicting pavement marking shall be removed for long term projects.
 - A Shadow Vehicle with a TMA should be used anytime it can be positioned 30 to 100 feet in advance of the area of crew exposure without adversely affecting the performance or quality of the work. If workers are no longer present but road or work conditions require the traffic control to remain in place, Type 3 Barricades or other channelizing devices may be substituted.
 - Additional Shadow Vehicles with TMAs may be positioned off the paved surface, next to those shown in order to protect a wider work space.
- TCP (2-3a)**
- Conflicting pavement markings shall be removed for long-term projects. For shorter durations where traffic is directed over a yellow centerline, channelizing devices which separate two-way traffic should be spaced on tapers at 20' or 15' if posted speeds are 35 mph or slower, and for tangent sections, at 1/2(S) where S is the speed in mph. This tighter device spacing is intended for the area of the conflicting markings, not the entire work zone.



TRAFFIC CONTROL PLAN
TRAFFIC SHIFTS ON
TWO-LANE ROADS

TCP (2-3) - 18

FILE:	DATE:	BY:	CHK:	APP:	CHK:
tcp(2-3)-18.dgn	December 1985				
REVISIONS		6379	54	001	SH 174, ETC
8-95	3-03				
1-97	2-12				
4-98	2-18	02		JOHNSON	23

DISCLAIMER of this standard is governed by the "Texas Engineering Practices Act". No warranty of any kind is made by TxDOT for any purpose whatsoever. TxDOT assumes no responsibility for the conversion of this standard to other formats or for incorrect results or damages resulting from its use.

DATE: FILE:

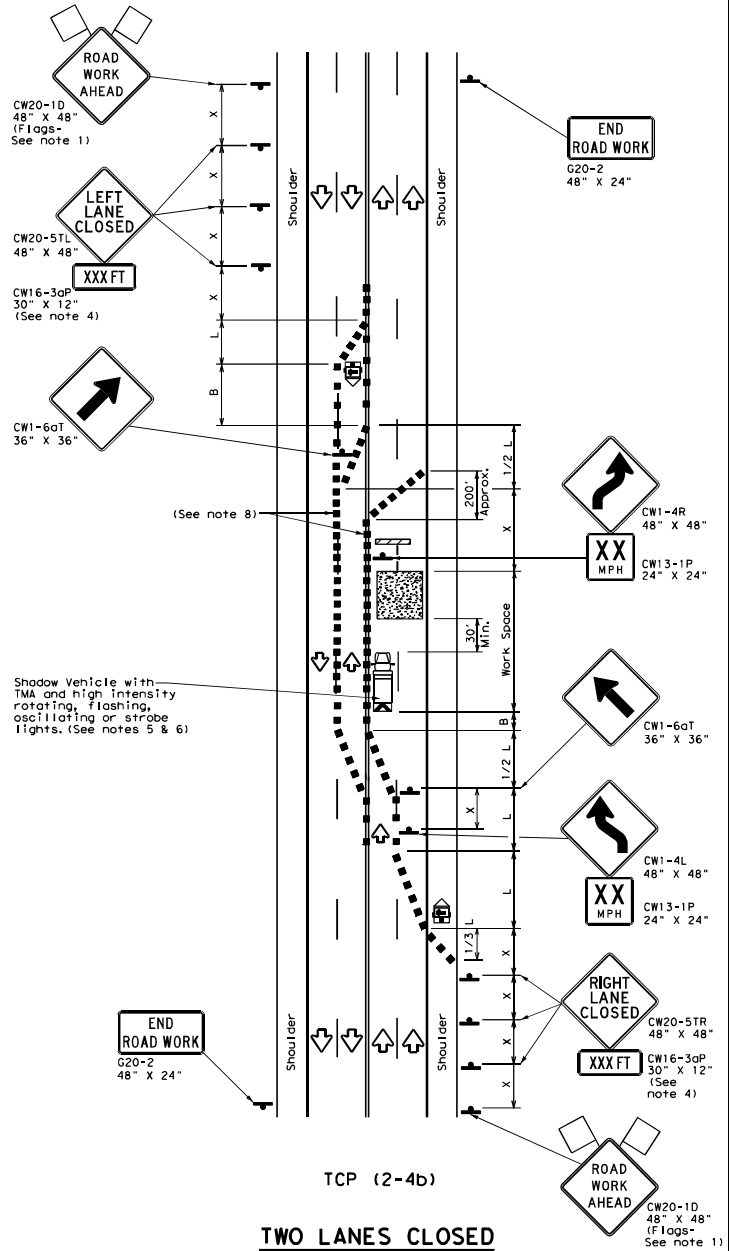
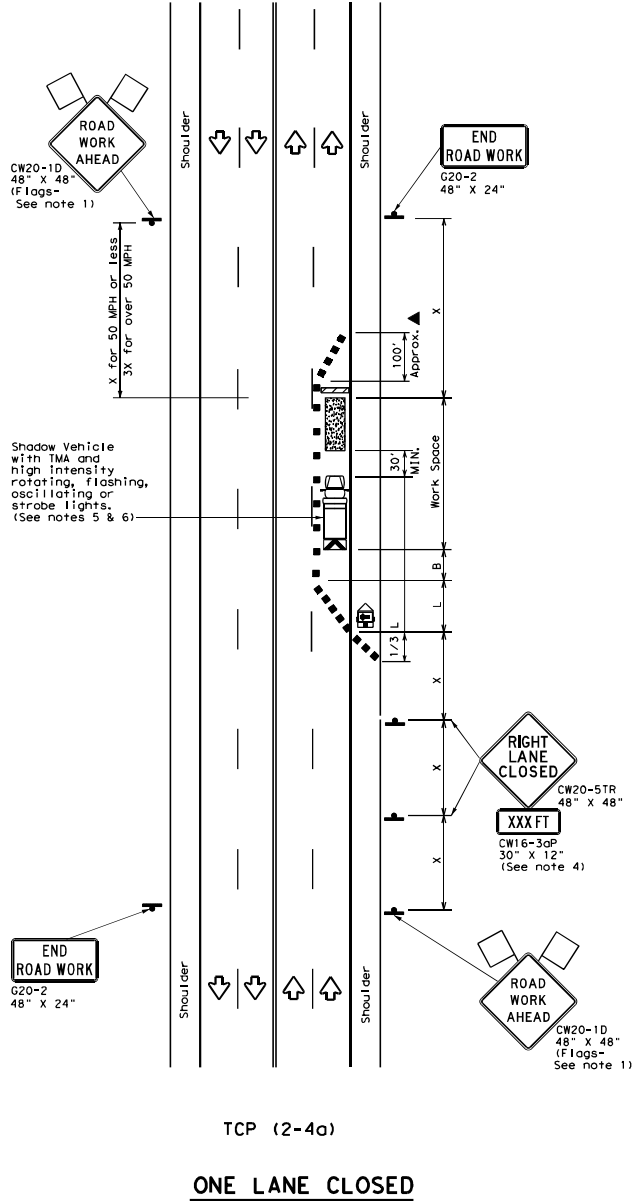

LEGEND			
	Type 3 Barricade		Channelizing Devices
	Heavy Work Vehicle		Truck Mounted Attenuator (TMA)
	Trailer Mounted Flashing Arrow Board		Portable Changeable Message Sign (PCMS)
	Sign		Traffic Flow
	Flag		Flagger

Posted Speed * *	Formula	Minimum Desirable Taper Lengths **			Suggested Maximum Spacing of Channelizing Devices		Minimum Sign Spacing * Distance	Suggested Longitudinal Buffer Space * B
		10' Offset	11' Offset	12' Offset	On a Taper	On a Tangent		
30	$L = \frac{WS^2}{60}$	150'	165'	180'	30'	60'	120'	90'
35		205'	225'	245'	35'	70'	160'	120'
40	L = WS	265'	295'	320'	40'	80'	240'	155'
45		450'	495'	540'	45'	90'	320'	195'
50	L = WS	500'	550'	600'	50'	100'	400'	240'
55		550'	605'	660'	55'	110'	500'	295'
60	L = WS	600'	660'	720'	60'	120'	600'	350'
65		650'	715'	780'	65'	130'	700'	410'
70	L = WS	700'	770'	840'	70'	140'	800'	475'
75		750'	825'	900'	75'	150'	900'	540'

* Conventional Roads Only
** Taper lengths have been rounded off.
L=Length of Taper (FT) W=Width of Offset (FT) S=Posted Speed (MPH)

TYPICAL USAGE				
MOBILE	SHORT DURATION	SHORT TERM STATIONARY	INTERMEDIATE TERM STATIONARY	LONG TERM STATIONARY
		✓	✓	

- GENERAL NOTES**
- Flags attached to signs where shown, are REQUIRED.
 - All traffic control devices illustrated are REQUIRED, except those denoted with the triangle symbol may be omitted when stated elsewhere in the plans, or for routine maintenance work, when approved by the Engineer.
 - The downstream taper is optional. When used, it should be 100 feet minimum length per lane.
 - For short term applications, when post mounted signs are not used, the distance legend may be shown on the sign face rather than on a CW16-3aP supplemental plaque.
 - A Shadow Vehicle with a TMA should be used anytime it can be positioned 30 to 100 feet in advance of the area of crew exposure without adversely affecting the performance or quality of the work. If workers are no longer present but road or work conditions require the traffic control to remain in place, Type 3 Barricades or other channelizing devices may be substituted for the Shadow Vehicle and TMA.
 - Additional Shadow Vehicles with TMAs may be positioned in each closed lane, on the shoulder or off the paved surface, next to those shown in order to protect a wider work space.
- TCP (2-4a)**
- If this TCP is used for a left lane closure, CW20-5TL "LEFT LANE CLOSED" signs shall be used and channelizing devices shall be placed on the centerline to protect the work space from opposing traffic with the arrow board placed in the closed lane near the end of the merging taper.
- TCP (2-4b)**
- For shorter durations where traffic is directed over a yellow centerline, channelizing devices which separate two-way traffic should be spaced on tapers at 20' or 15' if posted speeds are 35 mph or slower, and for tangent sections, at 1/2(S) where S is the speed in mph. This tighter device spacing is intended for the area of conflicting markings, not the entire work zone.

		Traffic Operations Division Standard	
TRAFFIC CONTROL PLAN LANE CLOSURES ON MULTILANE CONVENTIONAL ROADS			
TCP (2-4) - 18			
FILE:	top2-4a18.dgn	DATE:	December 1985
REV:	01	BY:	SH 174, ETC
8-95	3-03	6379	54
1-97	2-12		
4-98	2-18	02	JOHNSON
		SHEET NO. 24	

DISCLAIMER: This standard is governed by the "Texas Engineering Practice Act". No warranty of any kind is made by TxDOT for any purpose whatsoever. TxDOT assumes no responsibility for the conversion of this standard to other formats or for incorrect results or damages resulting from its use.

DATE: FILE:

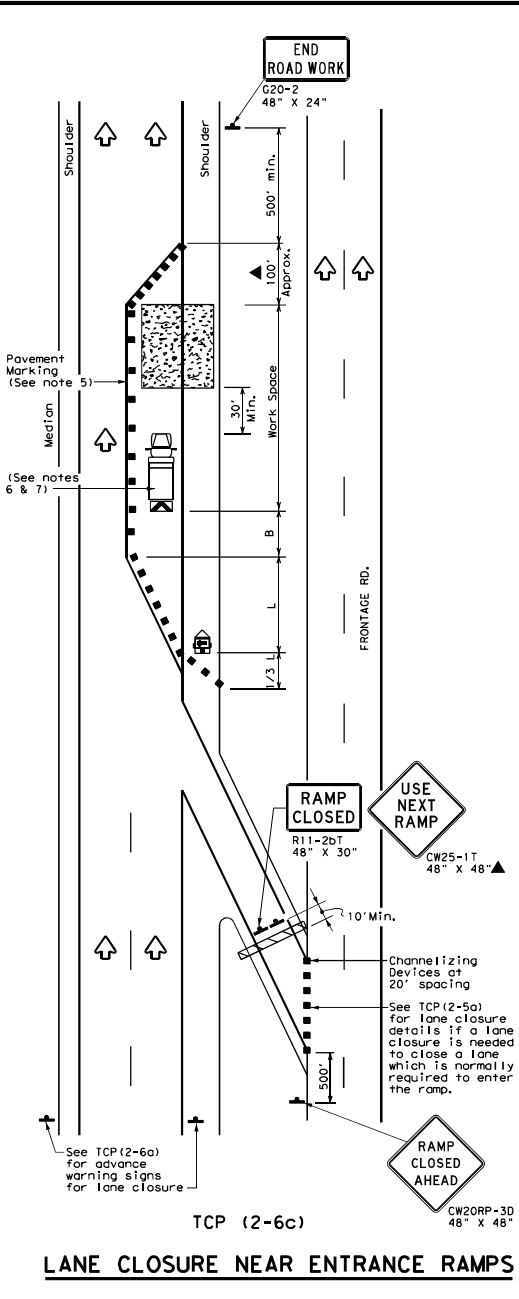
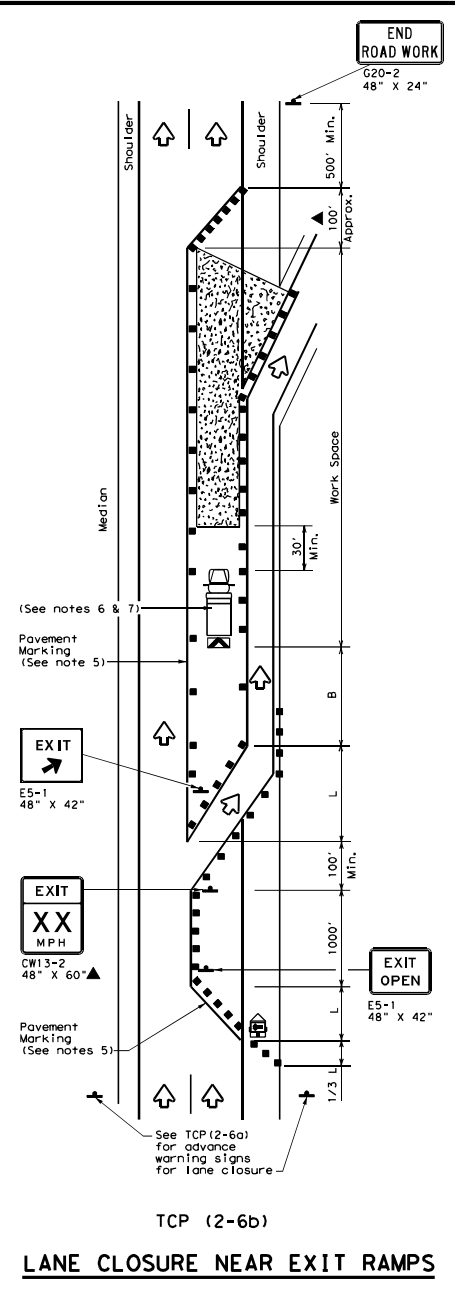
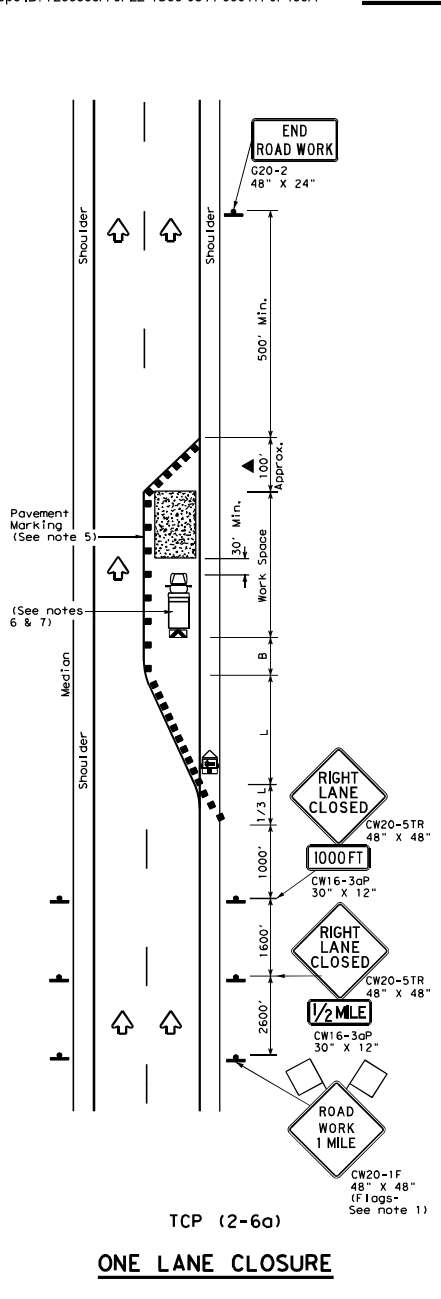

LEGEND

	Type 3 Barricade		Channelizing Devices
	Heavy Work Vehicle		Truck Mounted Attenuator (TMA)
	Trailer Mounted Flashing Arrow Board		Portable Changeable Message Sign (PCMS)
	Sign		Traffic Flow
	Flag		Flagger

Posted Speed *	Formula	Minimum Desirable Taper Lengths * x *			Suggested Maximum Spacing of Channelizing Devices		Minimum Sign Spacing *	Suggested Longitudinal Buffer Space "B"
		10' Offset	11' Offset	12' Offset	On a Taper	On a Tangent		
30	L = WS ² / 60	150'	165'	180'	30'	60'	120'	90'
35		205'	225'	245'	35'	70'	160'	120'
40		265'	295'	320'	40'	80'	240'	155'
45	L = WS	450'	495'	540'	45'	90'	320'	195'
50		500'	550'	600'	50'	100'	400'	240'
55		550'	605'	660'	55'	110'	500'	295'
60		600'	660'	720'	60'	120'	600'	350'
65		650'	715'	780'	65'	130'	700'	410'
70	700'	770'	840'	70'	140'	800'	475'	
75	750'	825'	900'	75'	150'	900'	540'	

* Conventional Roads Only
 ** Taper Lengths have been rounded off.
 L=Length of Taper (FT) W=Width of Offset (FT) S=Posted Speed (MPH)

TYPICAL USAGE

MOBILE	SHORT DURATION	SHORT TERM STATIONARY	INTERMEDIATE TERM STATIONARY	LONG TERM STATIONARY
			✓	✓

- GENERAL NOTES**
- Flags attached to signs where shown, are REQUIRED.
 - All traffic control devices illustrated are REQUIRED, except those denoted with the triangle symbol may be omitted when stated elsewhere in the plans, or for routine maintenance work, when approved by the Engineer.
 - Channelizing devices used to close lanes may be supplemented with the Chevron Alignment Sign placed on every other channelizing device. Chevrons may be attached to plastic drums as per BC Standards.
 - Channelizing devices used along the work space or along tangent sections may be supplemented with vertical panels (VP) placed on every other channelizing device. If night time conditions make it difficult to see at least two VPs, the VPs may be placed on each channelizing device.
 - The placement of pavement markings may be omitted on intermediate-term stationary work zones with the approval of the Engineer.
 - Shadow Vehicle with TMA and high intensity rotating, flashing, oscillating or strobe lights. Shadow Vehicle with TMA and high intensity rotating, flashing, oscillating or strobe lights. A Shadow Vehicle with a TMA should be used anytime it can be positioned 30 to 100 feet in advance of the area of crew exposure without adversely affecting the performance or quality of the work. If workers are no longer present but road or work conditions require the traffic control to remain in place, Type 3 Barricades or other channelizing devices may be substituted for the Shadow Vehicle and TMA.
 - Additional Shadow Vehicles with TMAs may be positioned in each closed lane, on the shoulder or off the paved surface, next to those shown in order to protect a wider work space.

Texas Department of Transportation
 Traffic Operations Division Standard

TRAFFIC CONTROL PLAN
LANE CLOSURES ON
DIVIDED HIGHWAYS
TCP (2-6) - 18

FILES: tcp2-6-18.dgn	DATE: December 1985	DWG: 6378	SECT: 54	JOB: 001	SH: 174	ETC:
2-94 4-98	REVISIONS	01	02	03	04	05
8-95 2-12						
1-97 2-18		02		JOHNSON		25
1166						

DISCLAIMER: of this standard is governed by the "Texas Engineering Practice Act". No warranty of any kind is made by TxDOT for any purpose whatsoever. TxDOT assumes no responsibility for the conversion of this standard to other formats or for incorrect results or damages resulting from its use.

DATE: FILE:

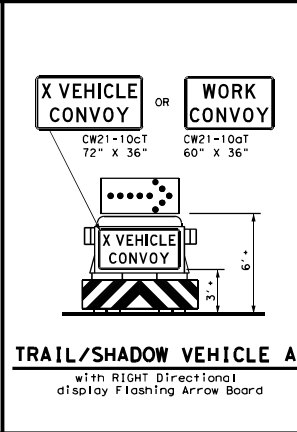
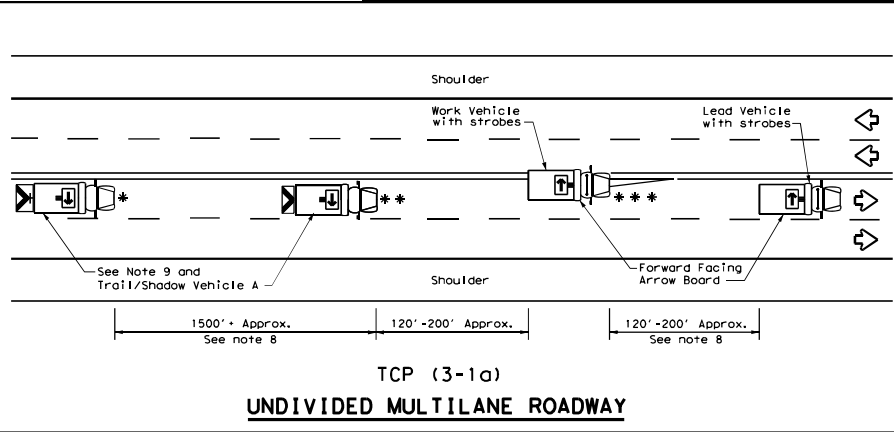

LEGEND		ARROW BOARD DISPLAY	
*	Trail Vehicle	[Symbol]	RIGHT Directional
**	Shadow Vehicle	[Symbol]	LEFT Directional
***	Work Vehicle	[Symbol]	Double Arrow
[Symbol]	Heavy Work Vehicle	[Symbol]	CAUTION (Alternating Diamond or 4 Corner Flash)
[Symbol]	Truck Mounted Attenuator (TMA)	[Symbol]	
[Symbol]	Traffic Flow	[Symbol]	

TYPICAL USAGE			
MOBILE	SHORT DURATION	SHORT TERM STATIONARY	LONG TERM STATIONARY
✓			

GENERAL NOTES

1. TRAIL, SHADOW, and LEAD vehicles shall be equipped with arrow boards as illustrated. When a LEAD vehicle is not used the WORK vehicle must be equipped with an arrow board. The Engineer will determine if the LEAD VEHICLE and/or TRAIL VEHICLE are required based on prevailing roadway conditions, traffic volume, and sight distance restrictions.
2. The use of amber high intensity rotating, flashing, oscillating, or strobe lights on vehicles are required. Blue high intensity rotating, flashing, oscillating or strobe lights when mounted on the driver's side of the vehicle may be operated simultaneously with the amber beacons or strobe lights.
3. The use of truck mounted attenuators (TMA) on the SHADOW VEHICLE and TRAIL VEHICLE are required.
4. Reflective sheeting on the rear of the TMA shall meet or exceed the reflectivity and color requirements of DEPARTMENTAL MATERIAL SPECIFICATION DMS 8300, Type A.
5. Flashing arrow boards shall be Type B or Type C as per the Barricade and Construction (BC) standards. The board shall be controlled from inside the vehicle.
6. Each vehicle shall have two-way radio communication capability.
7. When work convoys must change lanes, the TRAIL VEHICLE should change lanes first to shadow the other convoy vehicles.
8. Vehicle spacing between the TRAIL VEHICLE and the SHADOW VEHICLE will vary depending on sight distance restrictions. Motorists approaching the work convoy should be able to see the TRAIL VEHICLE in time to slow down and/or change lanes as they approach the TRAIL VEHICLE. Vehicle spacing between the WORK VEHICLE and SHADOW VEHICLE and vehicle spacing between WORK VEHICLE and LEAD VEHICLE may vary according to terrain, work activity and other factors.
9. "X VEHICLE CONVOY" (CW21-10cT) or "WORK CONVOY" (CW21-10aT) signs shall be used on TRAIL VEHICLES and SHADOW VEHICLES as shown. As an option 48" x 48" diamond shaped "WORK CONVOY" (CW21-10T) or "X VEHICLE CONVOY" (CW21-10BT) signs may be used where adequate mounting space exists. When used, the X VEHICLE CONVOY sign shall have the number of the convoy vehicles displayed on the sign in the number designation "X" location. The "X VEHICLE CONVOY" sign shall not be used on the SHADOW VEHICLE if a TRAIL VEHICLE is used.
10. On two-lane two-way roadways, the work and protection vehicles should pull over periodically to allow motor vehicle traffic to pass. If motorists are not allowed to pass the work convoy, a "DO NOT PASS" (R4-1) sign should be placed on the back of the rearmost protection vehicle.

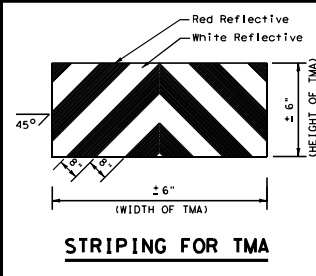
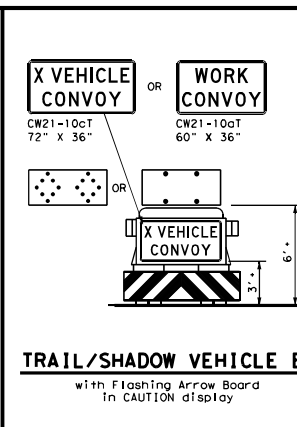
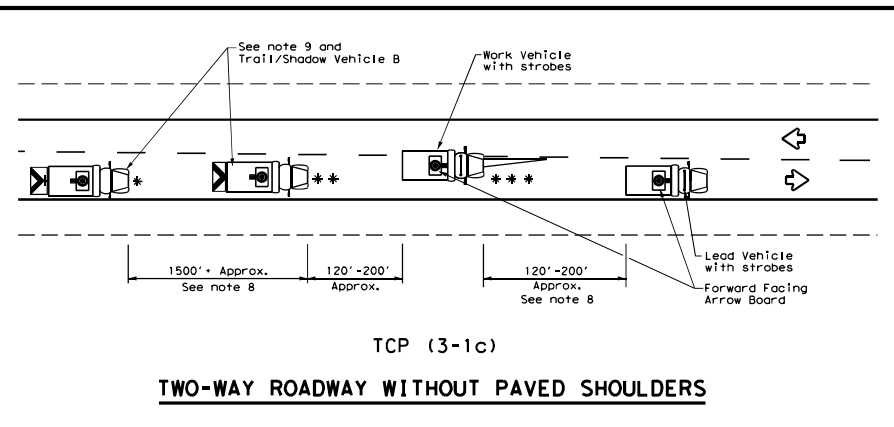
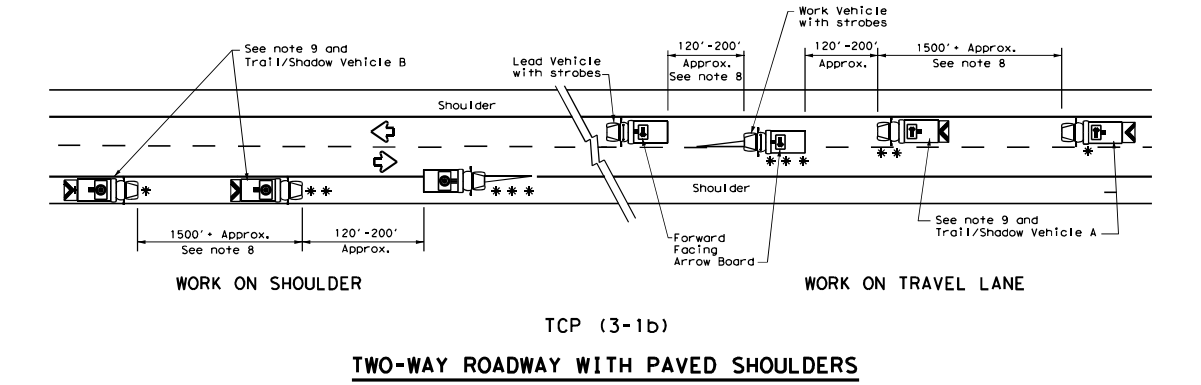

Traffic Operations Division Standard

**TRAFFIC CONTROL PLAN
MOBILE OPERATIONS
UNDIVIDED HIGHWAYS**

TCP(3-1)-13

FILE:	tcp3-1.dgn	DATE:	TxDOT	CHK:	TxDOT	DATE:	TxDOT	CHK:	TxDOT
REVISED:	December 1985	CONTRACT:	6378	SECTION:	54	JOB:	001	SHEET:	174, ETC
REVISIONS:	2-94 4-98	DISTRICT:	02	COUNTY:	JOHNSON	COUNTY:	JOHNSON	SHEET NO.:	26
	8-95 7-13								
	1-97								

DISCLAIMER: This standard is governed by the Texas Engineering Practice Act. No warranty of any kind is made by the use of this standard. The user of this standard is advised to consult with a professional engineer or architect for proper application of this standard to other forms or for incorrect results or damages resulting from its use.

DATE: _____ FILE: _____

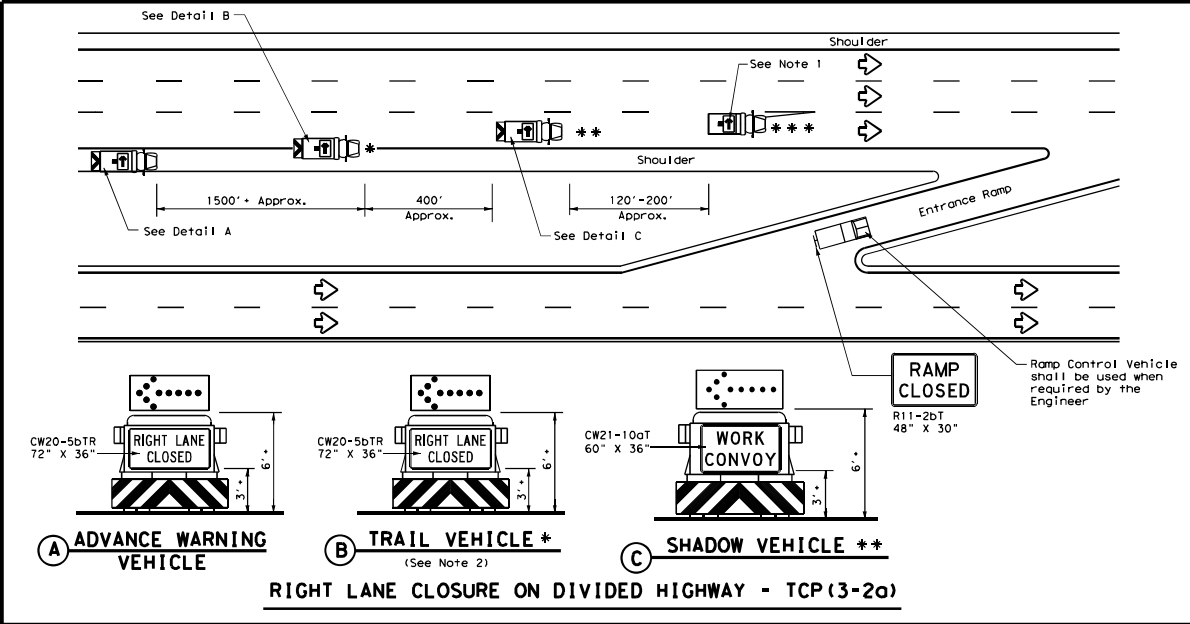

RIGHT LANE CLOSURE ON DIVIDED HIGHWAY - TCP(3-2a)

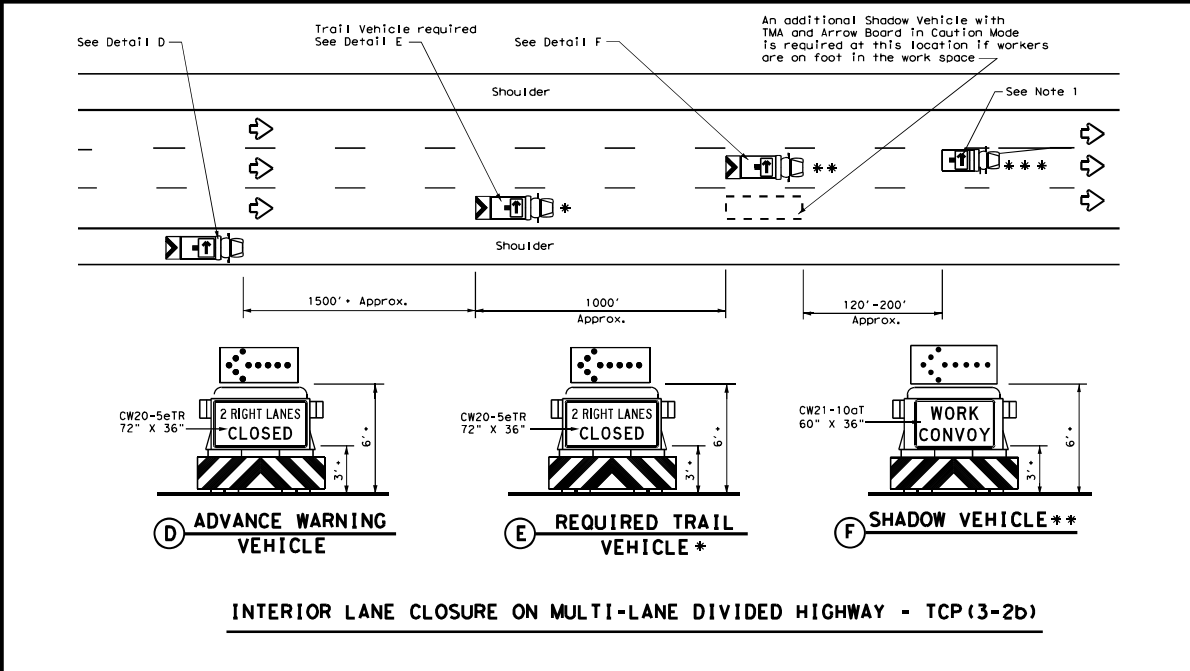

INTERIOR LANE CLOSURE ON MULTI-LANE DIVIDED HIGHWAY - TCP(3-2b)

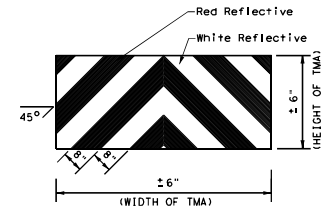

STRIPING FOR TMA

LEGEND		
* Trail Vehicle		ARROW BOARD DISPLAY
** Shadow Vehicle		
*** Work Vehicle		
	RIGHT Directional	
	LEFT Directional	
	Double Arrow	
	CAUTION (Alternating Diamond or 4 Corner Flash)	

TYPICAL USAGE				
MOBILE	SHORT DURATION	SHORT TERM STATIONARY	INTERMEDIATE TERM STATIONARY	LONG TERM STATIONARY
✓				

GENERAL NOTES

- ADVANCE WARNING, TRAIL and SHADOW vehicles shall be equipped with Type B or Type C flashing arrow boards as per the Barricade and Construction (BC) standards. Arrow boards on WORK vehicles will be optional based on the type of work being performed. The arrow boards shall be operated from inside the vehicle.
- For TCP(3-2a) the Engineer will determine if the TRAIL VEHICLE is required based on prevailing roadway conditions, traffic volume, and sight distance restrictions. All other vehicles shown for both TCP(3-2a) and TCP(3-2b) are required.
- The use of amber high intensity rotating, flashing, oscillating, or strobe lights on vehicles are required. Blue high intensity rotating, flashing, oscillating or strobe lights when mounted on the driver's side of the vehicle may be operated simultaneously with the amber beacons or strobe lights.
- The use of truck mounted attenuators (TMA) on the ADVANCE WARNING, SHADOW, and TRAIL vehicles are required.
- Reflective sheeting on the rear of the TMA shall meet or exceed the reflectivity and color requirements of DMS 8300, Type A.
- Each vehicle shall have two-way radio communication capability.
- When work convoys must change lanes, the TRAIL VEHICLE should change lanes first to shadow the other convoy vehicles.
- Vehicle spacing between the TRAIL VEHICLE and the SHADOW VEHICLE will vary depending on sight distance restrictions. Motorists approaching the work convoy should be able to see the TRAIL VEHICLE in time to slow down and/or change lanes as they approach the TRAIL VEHICLE. Vehicle spacing between the WORK VEHICLE and SHADOW VEHICLE may vary according to terrain, work activity and other factors.
- Standard 48" X 48" diamond shaped warning signs with the same message as those shown may be used where adequate mounting space exists.
- The signs shown should be used on the Advance Warning Vehicle. As an option, a portable changeable message sign (PCMS) or a truck mounted changeable message sign (TMCMS) with a minimum character height of 12", and displaying the same legend may be substituted for these signs. An appropriate directional arrow display, simulating the size and legibility of the flashing arrow board, must be used in the second phase of the PCMS/TMCMS message. When this is done, the arrow board will not be required on the Advance Warning Vehicle.
- Standard diamond shape versions of the CW20-5 series signs may be used as an option if the rectangular signs shown are not available.
- The principles on this sheet may be used to close lanes from the left side of the roadway considering the number of lanes, shoulder width, sight distance, and ramp frequency.
- Signs and flashing arrow board modes shall be appropriately altered when implementing left lane closures or interior closures which close the left lanes.
- The Advance Warning Vehicle may straddle the edgeline when shoulder width makes it necessary.

		Traffic Operations Division Standard	
TRAFFIC CONTROL PLAN MOBILE OPERATIONS DIVIDED HIGHWAYS			
TCP(3-2)-13			
FILE: tcp3-2.dgn	DWG: TXDOT	CHK: TXDOT	DWG: TXDOT
CO: TXDOT	DATE: December 1985	CONT: SECT	JOB: HIGHWAY
2-94	4-98	6379	54
8-95	7-13	01ST	001
1-97		02	JOHNSON
			SM 174, ETC
			SHEET NO.
			27

DISCLAIMER: This standard is governed by the "Texas Engineering Practices Act". No warranty of any kind is made by TxDOT for any purpose whatsoever. TxDOT assumes no responsibility for the conversion of this standard to other formats or for incorrect results or damages resulting from its use.

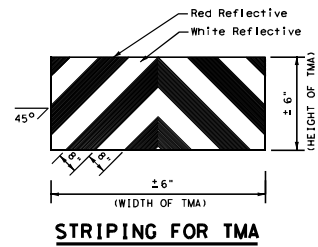
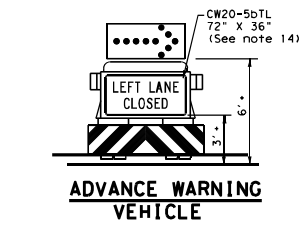
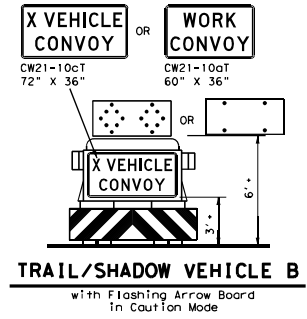
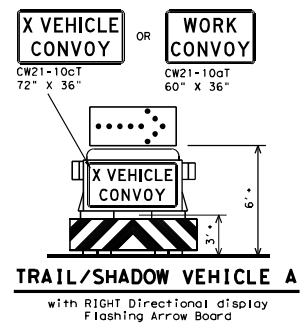
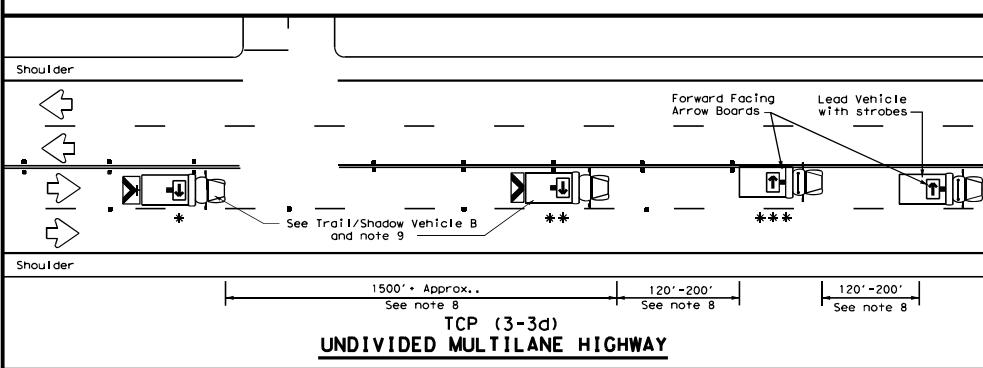
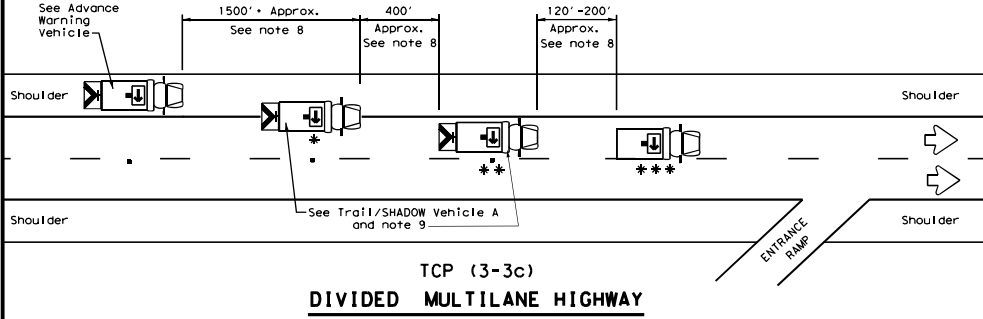
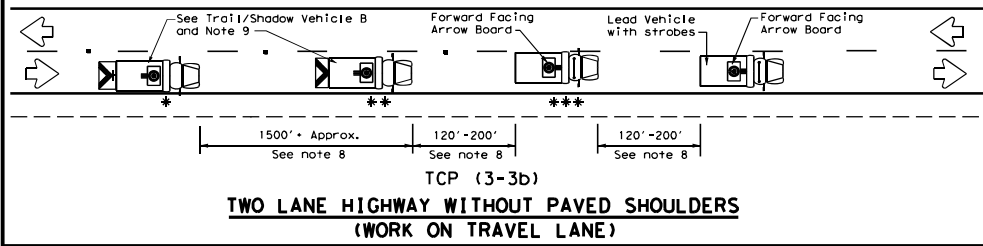
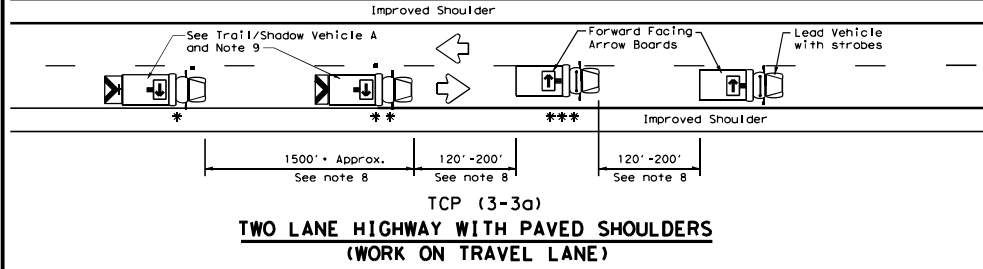

LEGEND			
* Trail Vehicle		ARROW BOARD DISPLAY	
** Shadow Vehicle			
*** Work Vehicle		RIGHT Directional	
Heavy Work Vehicle		LEFT Directional	
Truck Mounted Attenuator (TMA)		Double Arrow	
Traffic Flow		CAUTION (Alternating Diamond or 4 Corner Flash)	

TYPICAL USAGE			
MOBILE	SHORT DURATION	SHORT TERM STATIONARY	LONG TERM STATIONARY
✓			

GENERAL NOTES

1. TRAIL, SHADOW, and LEAD vehicles shall be equipped with arrow boards as illustrated. When a LEAD vehicle is not used on two way roads the WORK vehicle must have an arrow board. For divided roadways, the arrow board on the WORK vehicle is optional based on the type of work being performed. The Engineer will determine if the LEAD vehicle and/or TRAIL vehicle are required based on prevailing roadway conditions, traffic volume, and sight distance restrictions.
2. The use of amber high intensity rotating, flashing, oscillating, or strobe lights on vehicles are required. Blue high intensity rotating, flashing, oscillating, or strobe lights when mounted on the driver's side of the vehicle may be operated simultaneously with the amber beacons or strobe lights.
3. The use of truck mounted attenuators (TMA) on the SHADOW VEHICLE, ADVANCE WARNING and TRAIL VEHICLE are required.
4. Reflective sheeting on the rear of the TMA shall meet or exceed the reflectivity and color requirements of DEPARTMENTAL MATERIAL SPECIFICATION DMS 8300, Type A.
5. Flashing arrow boards shall be Type B or Type C as per the Barricade and Construction (BC) standards. The board shall be controlled from inside the vehicle.
6. Each vehicle shall have two-way radio communication capability.
7. When work convoys must change lanes, the TRAIL VEHICLE should change lanes first to shadow the other convoy vehicles.
8. Vehicle spacing between the TRAIL VEHICLE and the SHADOW VEHICLE will vary depending on sight distance restrictions, motorist's approaching the convoy should be able to see the TRAIL VEHICLE in time to slow down and/or change lanes as they approach the TRAIL VEHICLE. Vehicle spacing between the WORK VEHICLE and SHADOW VEHICLE and vehicle spacing between WORK VEHICLE and LEAD VEHICLE may vary according to terrain, work activity and other factors.
9. X VEHICLE CONVOY (CW21-10cT) or WORK CONVOY (CW21-10aT) signs shall be used on TRAIL VEHICLES and SHADOW VEHICLES as shown. As an option 48" x 48" diamond shaped WORK CONVOY (CW21-10T) or X VEHICLE CONVOY (CW21-10bT) signs may be used where adequate mounting space exists. When used, the X VEHICLE CONVOY sign shall have the number of the convoy vehicles displayed on the sign in the number designation "X" location. The X VEHICLE CONVOY sign shall not be used on the SHADOW VEHICLE if a TRAIL VEHICLE is used.
10. For divided highways with two or three lanes in one direction, the appropriate LEFT LANE CLOSED (CW20-5bTL), RIGHT LANE CLOSED (CW20-5bTR), or CENTER LANE CLOSED (CW20-5aT) sign should be used on the Advance Warning Vehicle. As an option, a portable changeable message sign (PCMS) or truck mounted changeable message sign (TMCMS) with a minimum character height of 12", and displaying the same legend may be substituted for these signs. An appropriate directional arrow display, simulating the size and legibility of the flashing arrow board may be used in the second phase of the PCMS/TMCMS message. When this is done, the arrow board will not be required on the Advance Warning Vehicle.
11. A double arrow shall not be displayed on the arrow board on the Advance Warning Vehicle.
12. For divided highways with three or four lanes in each direction, use TCP(3-2).
13. Standard diamond shape versions of the CW20-5 series signs may be used as an option if the rectangular signs shown are not available.
14. The Advance Warning Vehicle may straddle the edge line when Shoulder width makes it necessary.
15. On two-lane two-way roadways, the work and protection vehicles should pull over periodically to allow motor vehicle traffic to pass. If motorists are not allowed to pass the work convoy, a DO NOT PASS (R4-1) sign should be placed on the back of the rearmost protection vehicle.

TRAFFIC CONTROL PLAN
MOBILE OPERATIONS
RAISED PAVEMENT
MARKER INSTALLATION/
REMOVAL
TCP (3-3) - 14

FILES	tcp3-3.dgn	DATE	TxDOT	BY	TxDOT	DATE	TxDOT
©TxDOT	September 1987	REV	DATE	BY	DESCRIPTION	SHEET NO.	TOTAL SHEETS
		6379	94	001	SM 174, ETC		
		8-99	7-13		COUNTY		
		1-97	7-14	02	JOHNSON		28

177

DISCLAIMERS of this standard is governed by the "Texas Engineering Practices Act". No warranty of any kind is made by TxDOT for any purpose whatsoever. TxDOT assumes no responsibility for the conversion of this standard to other formats or for incorrect results or damages resulting from its use.

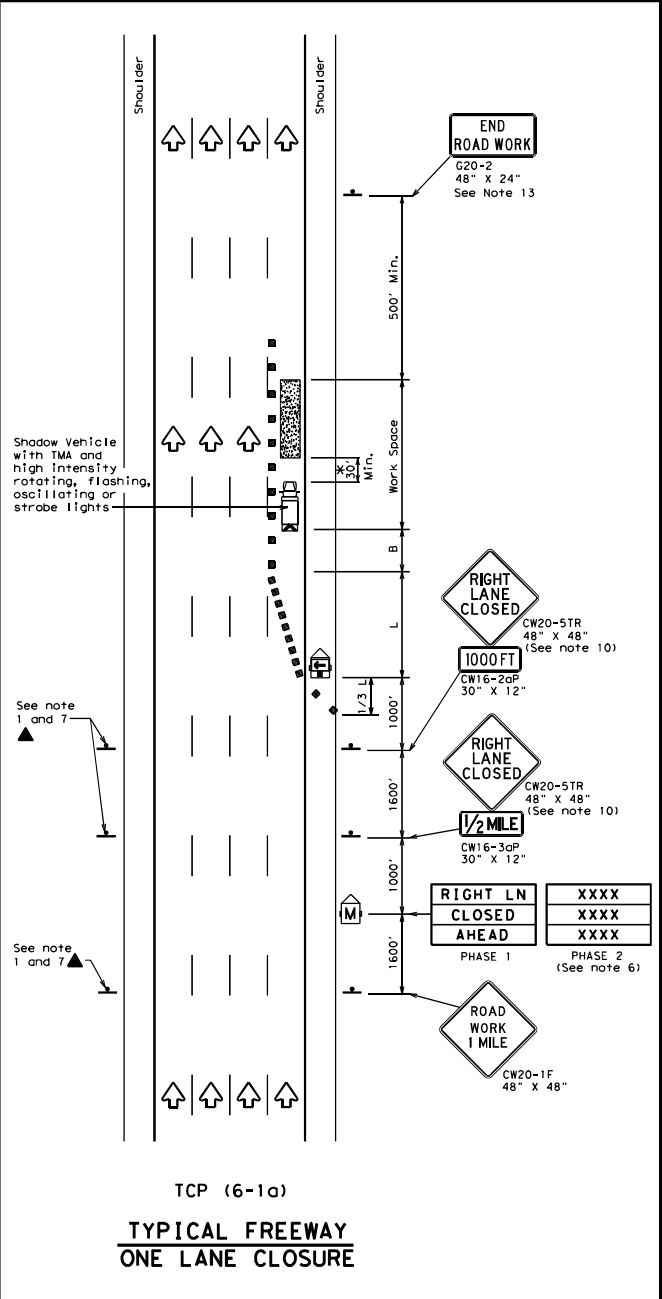

TCP (6-1a)
**TYPICAL FREEWAY
ONE LANE CLOSURE**

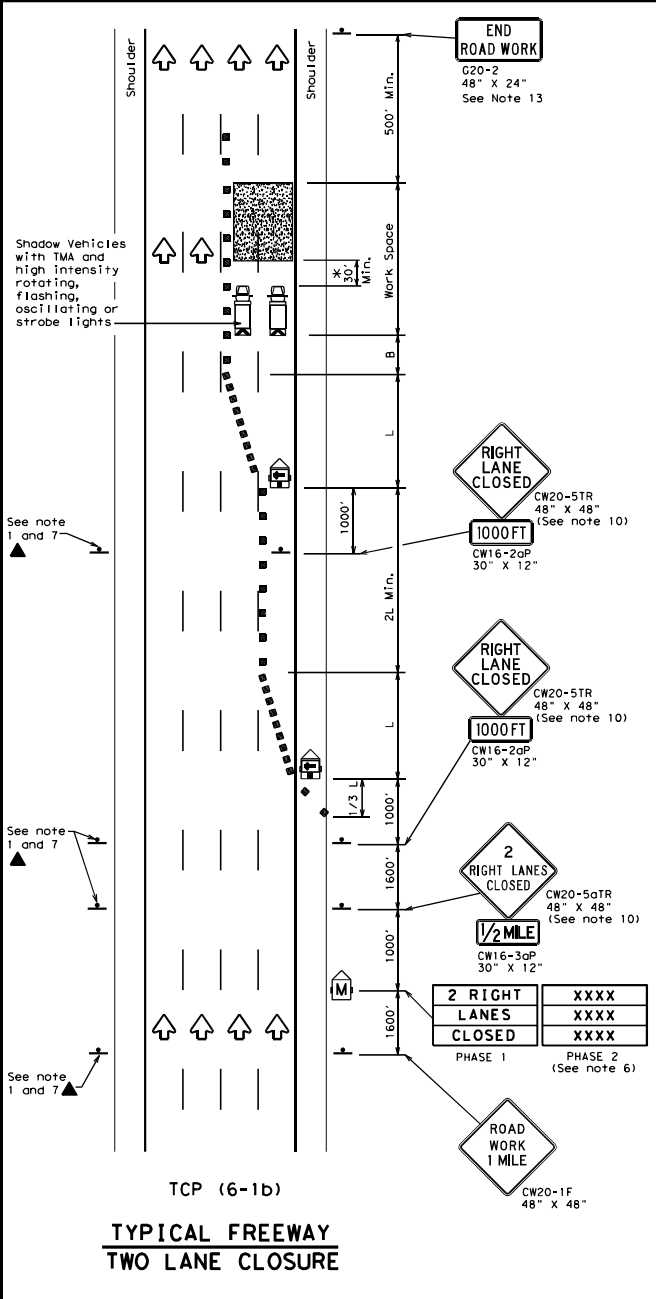

TCP (6-1b)
**TYPICAL FREEWAY
TWO LANE CLOSURE**

LEGEND			
	Type 3 Barricade		Channelizing Devices
	Heavy Work Vehicle		Truck Mounted Attenuator (TMA)
	Trailer Mounted Flashing Arrow Board		Portable Changeable Message Sign (PCMS)
	Sign		Traffic Flow
	Flag		Flagger

Posted Speed	Formula	Minimum Desirable Taper Lengths "L"			Suggested Maximum Spacing of Channelizing Devices		Suggested Longitudinal Buffer Space "B"
		10' Offset	11' Offset	12' Offset	On a Taper	On a Tangent	
45	L = WS	450'	495'	540'	45'	90'	195'
50		500'	550'	600'	50'	100'	240'
55		550'	605'	660'	55'	110'	295'
60		600'	660'	720'	60'	120'	350'
65		650'	715'	780'	65'	130'	410'
70		700'	770'	840'	70'	140'	475'
75		750'	825'	900'	75'	150'	540'
80		800'	880'	960'	80'	160'	615'

**Taper lengths have been rounded off.
L=Length of Taper (FT) W=Width of Offset(FT) S=Posted Speed(MPH)

TYPICAL USAGE				
MOBILE	SHORT DURATION	SHORT TERM STATIONARY	INTERMEDIATE TERM STATIONARY	LONG TERM STATIONARY
	✓	✓	✓	

GENERAL NOTES

- All traffic control devices illustrated are REQUIRED. Devices denoted with the triangle symbol may be omitted when stated elsewhere in the plans.
- Drums or 42" cones are the typical channelizing devices. For intermediate term stationary work, drums shall be used on tapers with drums or 42" cones used on tangent sections. Other channelizing devices may be used as directed by the Engineer.
- All construction signs and barricades placed during any phase of work shall remain in place until removal is approved by the Engineer.
- The Engineer may direct the Contractor to furnish additional signs and barricades as required to maintain traffic flow, detours and motorist safety during construction.
- Static message boards or changeable message signs stating the date and duration of ramp or freeway lane closures shall be placed a minimum of seven (7) calendar days in advance of the actual closure.
- Phase 2 of the PCMS message should include appropriate information formatted as shown on BC(6), such as "MERGE LEFT," recommended advisory speed, delay information, or other specific warnings.
- Duplicate construction warning signs should be erected on the medians side of freeways where median width will permit and traffic volume justifies the signing.
- The number of closed lanes may be increased provided the spacing of traffic control devices, taper lengths and tangent lengths meet the requirements of the MUTCD.
- Warning signs for intermediate term stationary work should be mounted at 7' to the bottom of the sign.
- Warning signs shown shall be appropriately altered for left lane closures. When signs are mounted at 1' height for short term stationary or short duration work, sign versions shown in the SHSD for Texas with distances on the sign face rather than mounted on a plaque below the sign may be used.
- When possible, PCMS units should be located in advance of the last available exit ramp prior to the lane closure to allow motorists an alternate route. They may also be relocated to improve advance warning in case of unanticipated queuing or congestion.
- For intermediate term stationary work at night, floodlights should be used to illuminate the work area and equipment crossings. Floodlights shall not produce a disabling glare condition for road users or workers.
- The END ROAD WORK (G20-2) sign may be omitted when it conflicts with G20-2 signs already in place on the project.

*A shadow vehicle equipped with a Truck Mounted Attenuator is typically required. A shadow vehicle equipped with a TMA should be used if it can be positioned 30' to 100' in advance of the area of crew exposure without adversely affecting the work performance.



**TRAFFIC CONTROL PLAN
FREEWAY LANE CLOSURES**

TCP (6-1) - 12

FILE:	tcp6-1.dgn	DWG:	TxDOT	CHK:	TxDOT	DWG:	TxDOT	CHK:	TxDOT
© TxDOT	February 1998	CONT:	54	SEC:	001	JOB:	SH 174, ETC		
8-12	REVISIONS	DIST:	02	COUNTY:	JOHNSON	SHEET NO.:	29		

DATE:
FILE:

DISCLAIMER: The use of this standard is governed by the "Texas Engineering Practice Act". No warranty of any kind is made by TxDOT for any purpose whatsoever. TxDOT assumes no responsibility for the conversion of this standard to other formats or for incorrect results or damages resulting from its use.

DATE: _____
 FILE: _____

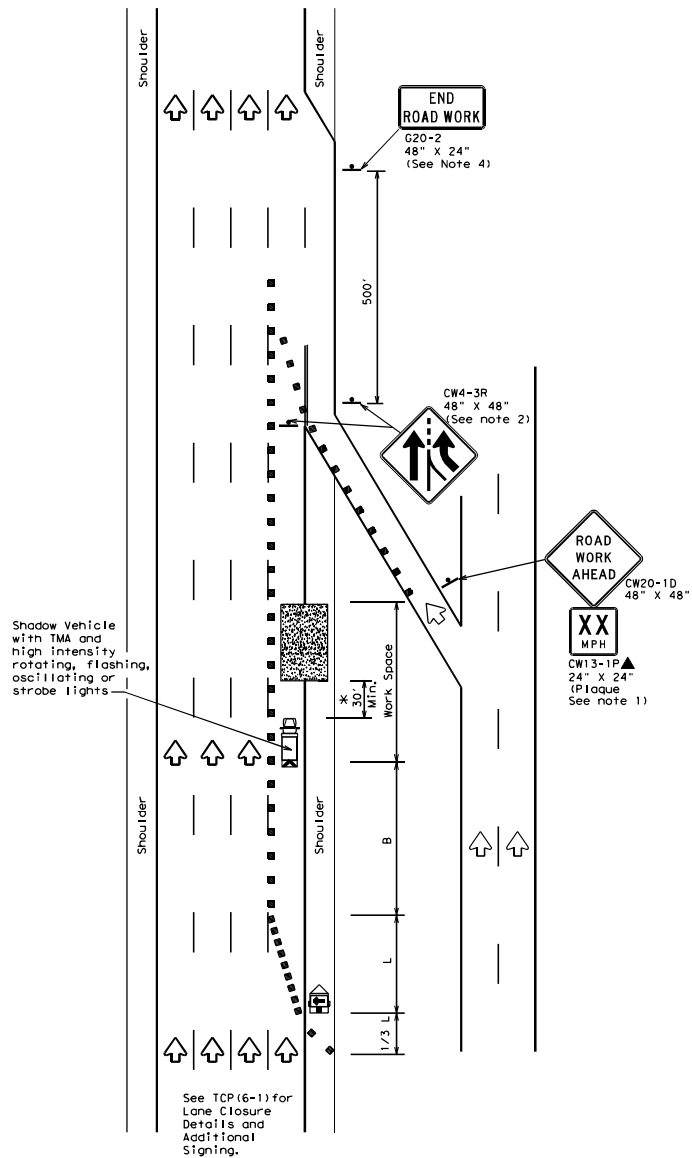

TCP (6-2a)
ENTRANCE RAMP OPEN
WORK WITHIN 500' OF RAMP

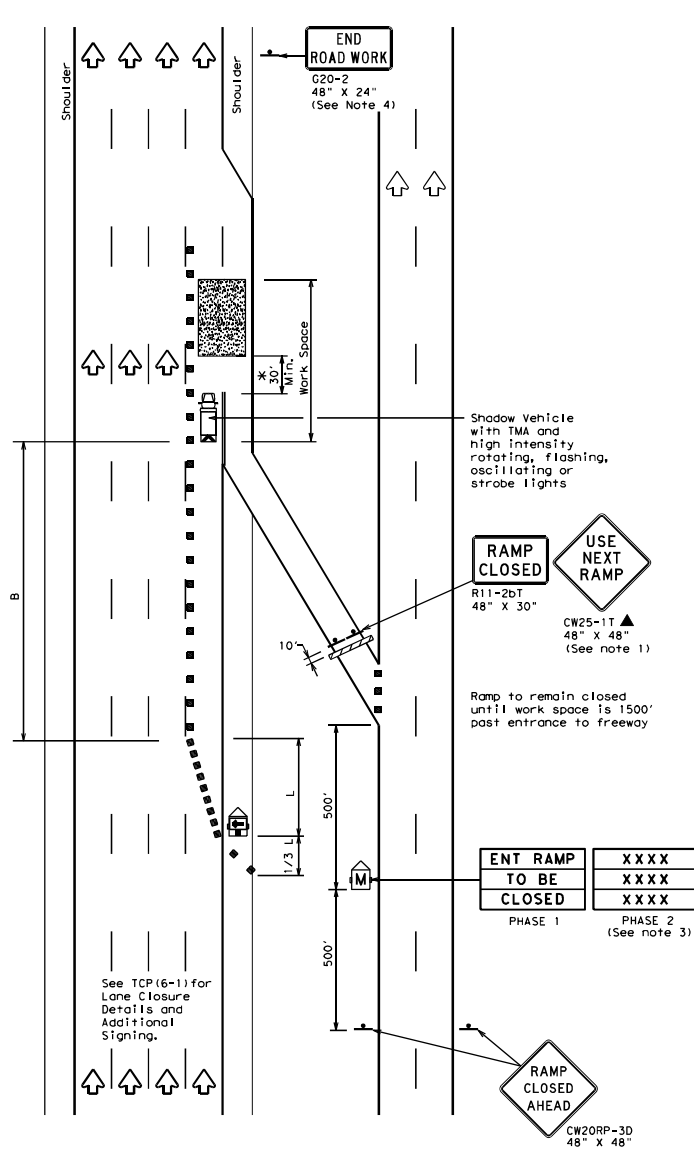

TCP (6-2b)
ENTRANCE RAMP CLOSED

LEGEND			
	Type 3 Barricade		Channelizing Devices
	Heavy Work Vehicle		Truck Mounted Attenuator (TMA)
	Trailer Mounted Flashing Arrow Board		Portable Changeable Message Sign (PCMS)
	Sign		Traffic Flow
	Flag		Flagger

Posted Speed	Formula	Minimum Desirable Taper Lengths "L"			Suggested Maximum Spacing of Channelizing Devices		Suggested Longitudinal Buffer Space "B"
		10' Offset	11' Offset	12' Offset	On a Taper	On a Tangent	
45	L = WS	450'	495'	540'	45'	90'	195'
50		500'	550'	600'	50'	100'	240'
55		550'	605'	660'	55'	110'	295'
60		600'	660'	720'	60'	120'	350'
65		650'	715'	780'	65'	130'	410'
70		700'	770'	840'	70'	140'	475'
75		750'	825'	900'	75'	150'	540'
80		800'	880'	960'	80'	160'	615'

** Taper lengths have been rounded off.
 L=Length of Taper (FT) W=Width of Offset (FT) S=Posted Speed (MPH)

TYPICAL USAGE				
MOBILE	SHORT DURATION	SHORT TERM STATIONARY	INTERMEDIATE TERM STATIONARY	LONG TERM STATIONARY
	✓	✓	✓	

GENERAL NOTES

- All traffic control devices illustrated are REQUIRED. Devices denoted with the triangle symbol may be omitted when stated elsewhere in the plans.
- ADDED LANE Symbol (CW4-3) sign may be omitted when sign between ramp and mainline can be seen from both roadways.
- See "Advance Notice List" on BC(6) for recommended date and time formatting options for PCMS Phase 2 message.
- The END ROAD WORK (G20-2) sign may be omitted when it conflicts with G20-2 signs already in place on the project.

XA shadow vehicle equipped with a Truck Mounted Attenuator is typically required. A shadow vehicle equipped with a TMA shall be used if it can be positioned 30' to 100' in advance of the area of crew exposure without adversely affecting the work performance.

Additional requirements for lane closures and advance signing shall be as shown on TCP (6-1) or as directed by the Engineer.



TRAFFIC CONTROL PLAN
WORK AREA NEAR RAMP

TCP (6-2) - 12

FILE: tcp6-2.dgn	DATE: 1/20/99	CREATED: 1/20/99	DATE: 1/20/99	CREATED: 1/20/99
© TxDOT February 1994	COM: 5379	SECT: 54	JOB: 001	HIGHWAY: SH 174, ETC
REVISIONS:	1-97 8-98	DIST:	COUNTY:	SHEET NO.:
	4-98 8-12	02	JOHNSON	30

DISCLAIMER: The use of this standard is governed by the Texas Engineering Practice Act. No warranty of any kind is made by the Board of Professional Engineers and Surveyors for incorrect results or damages resulting from its use.

DATE: FILE:

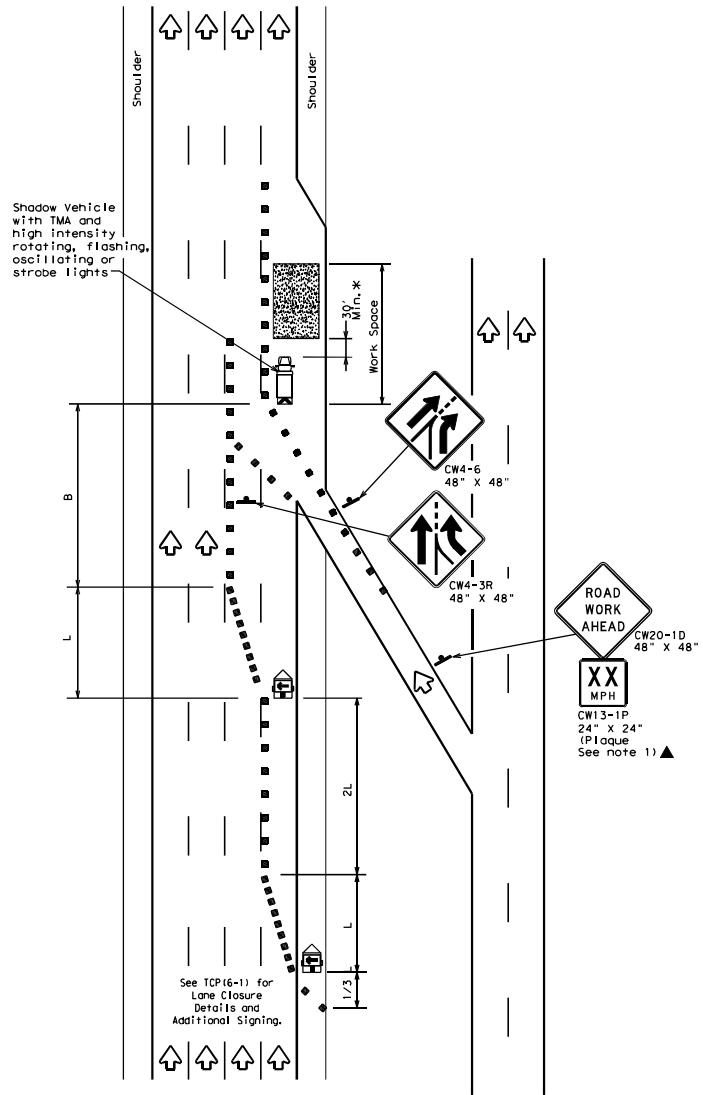

TCP (6-3a)
ENTRANCE RAMP OPEN

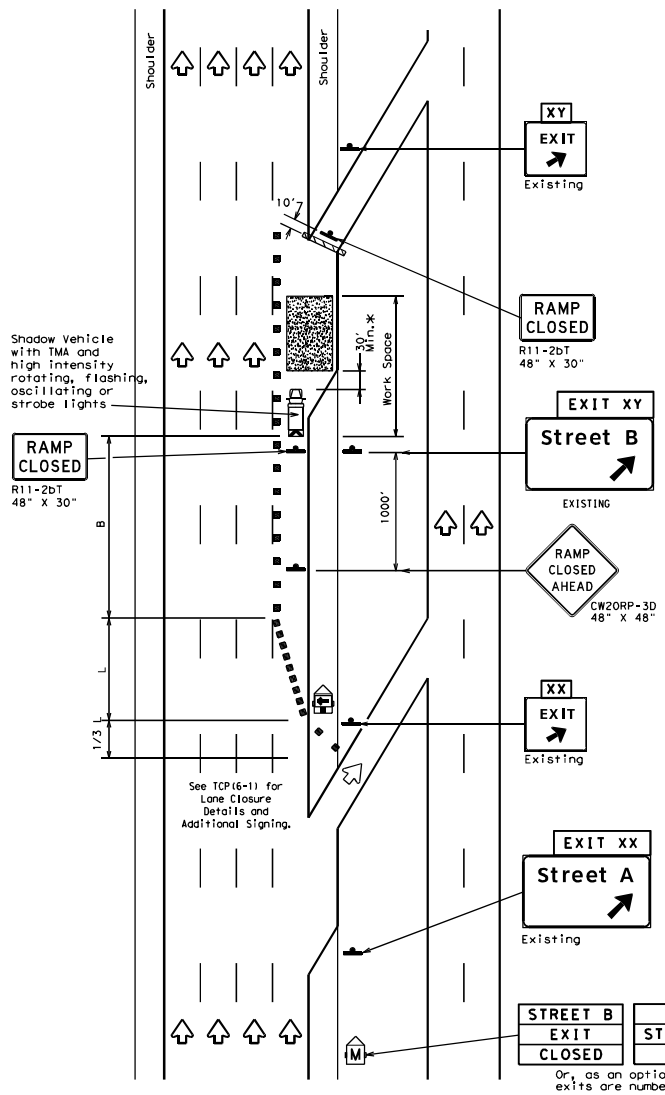

TCP (6-3b)
EXIT RAMP CLOSED
TRAFFIC EXITS PRIOR TO CLOSED RAMP

LEGEND			
	Type 3 Barricade		Channelizing Devices
	Heavy Work Vehicle		Truck Mounted Attenuator (TMA)
	Trailer Mounted Flashing Arrow Board		Portable Changeable Message Sign (PCMS)
	Sign		Traffic Flow
	Flag		Flagger

Posted Speed	Formula	Minimum Desirable Taper Lengths "L" **			Suggested Maximum Spacing of Channelizing Devices		Suggested Longitudinal Buffer Space "B"
		10' Offset	11' Offset	12' Offset	On a Taper	On a Tangent	
45	L = WS	450'	495'	540'	45'	90'	195'
50		500'	550'	600'	50'	100'	240'
55		550'	605'	660'	55'	110'	295'
60		600'	660'	720'	60'	120'	350'
65		650'	715'	780'	65'	130'	410'
70		700'	770'	840'	70'	140'	475'
75		750'	825'	900'	75'	150'	540'
80		800'	880'	960'	80'	160'	615'

** Taper lengths have been rounded off.
L=Length of Taper (FT) W=Width of Offset (FT) S=Posted Speed (MPH)

TYPICAL USAGE				
MOBILE	SHORT DURATION	SHORT TERM STATIONARY	INTERMEDIATE TERM STATIONARY	LONG TERM STATIONARY
	✓	✓	✓	

GENERAL NOTES:
1. All traffic control devices illustrated are REQUIRED. Devices denoted with the triangle symbol may be omitted when stated elsewhere in the plans.

*A shadow vehicle equipped with a Truck Mounted Attenuator is typically required. A shadow vehicle equipped with a TMA shall be used if it can be positioned 30' to 100' in advance of the area of crew exposure without adversely affecting the work performance.

Additional requirements for lane closures and advance signing shall be as shown on TCP (6-1) or as directed by the Engineer.

STREET B EXIT CLOSED	USE STREET A EXIT
EXIT XY CLOSED	USE EXIT XX

Or, as an option when exits are numbered

Place 1 mile (approx.) in advance of Street A exit.



**TRAFFIC CONTROL PLAN
WORK AREA BEYOND RAMP**

TCP (6-3) - 12

FILES: tcp6-3.dgn	DATE: Tx00T	CHK: Tx00T	DATE: Tx00T	CHK: Tx00T
© Tx00T February 1994	COM: 6379	SECT: 54	JOB: 001	HIGHWAY: SH 174, ETC
1-97 8-98	REVISTOR:	01ST:	COUNTY:	SHEET NO.:
4-98 8-12	02	JOHNSON		31

DISCLAIMER: The use of this standard is governed by the "Texas Engineering Practice Act". No warranty of any kind is made by TxDOT for any purpose whatsoever. TxDOT assumes no responsibility for the conversion of this standard to other formats or for incorrect results or damages resulting from its use.

DATE: _____
TITLE: _____

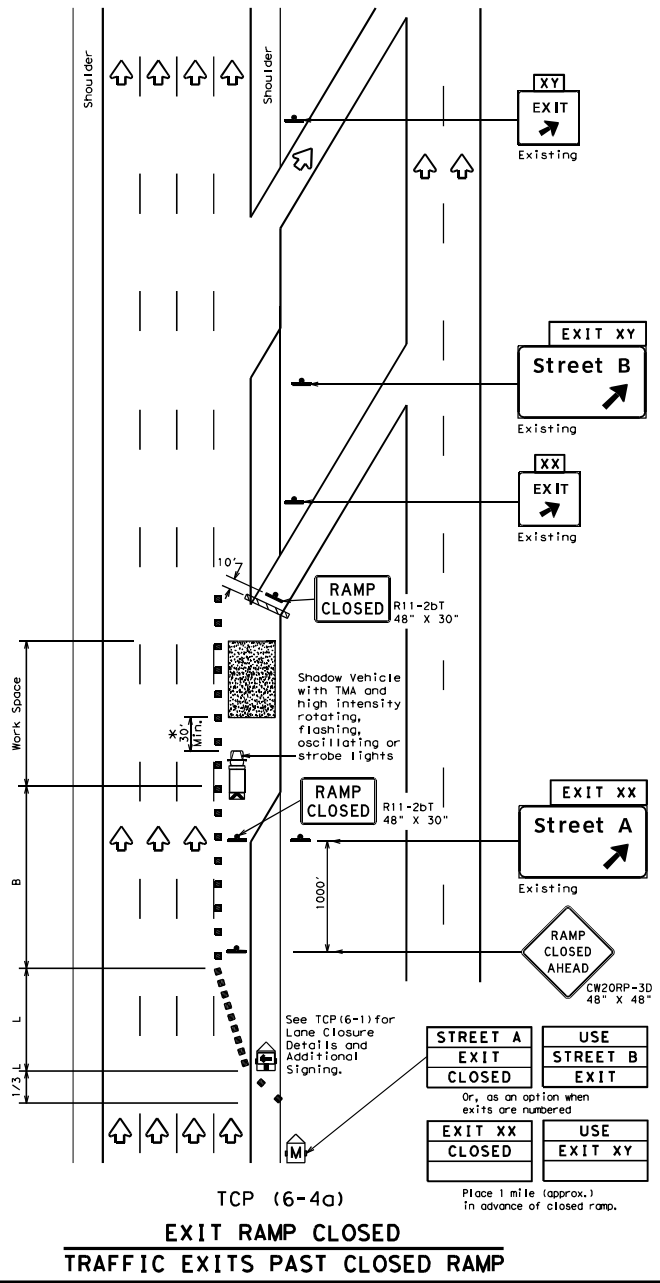

TCP (6-4a)

EXIT RAMP CLOSED
TRAFFIC EXITS PAST CLOSED RAMP

See TCP(6-1) for Lane Closure Details and Additional Signing.

STREET A EXIT CLOSED	USE STREET B EXIT
EXIT XX CLOSED	USE EXIT XY

Or, as an option when exits are numbered

Place 1 mile (approx.) in advance of closed ramp.

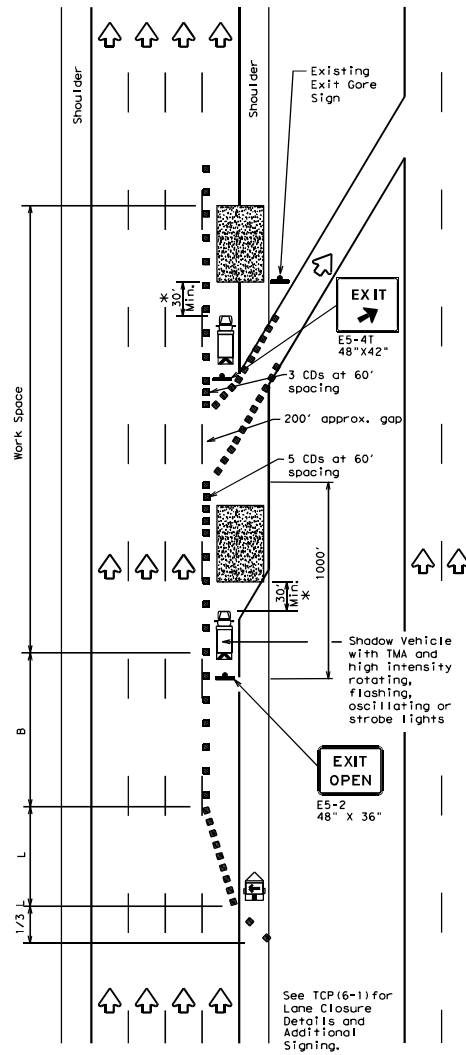

TCP (6-4b)

EXIT RAMP OPEN

LEGEND			
	Type 3 Barricade		Channelizing Devices (CDs)
	Heavy Work Vehicle		Truck Mounted Attenuator (TMA)
	Trailer Mounted Flashing Arrow Board		Portable Changeable Message Sign (PCMS)
	Sign		Traffic Flow
	Flag		Flagger

Posted Speed	Formula	Minimum Desirable Taper Lengths "L"			Suggested Maximum Spacing of Channelizing Devices		Suggested Longitudinal Buffer Space "B"
		10' Offset	11' Offset	12' Offset	On a Taper	On a Tangent	
45	L = WS	450'	495'	540'	45'	90'	195'
50		500'	550'	600'	50'	100'	240'
55		550'	605'	660'	55'	110'	295'
60		600'	660'	720'	60'	120'	350'
65		650'	715'	780'	65'	130'	410'
70		700'	770'	840'	70'	140'	475'
75		750'	825'	900'	75'	150'	540'
80		800'	880'	960'	80'	160'	615'

** Taper lengths have been rounded off.
L=Length of Taper (FT) W=Width of Offset (FT) S=Posted Speed (MPH)

TYPICAL USAGE				
MOBILE	SHORT DURATION	SHORT TERM STATIONARY	INTERMEDIATE TERM STATIONARY	LONG TERM STATIONARY
	✓	✓	✓	

GENERAL NOTES

- All traffic control devices illustrated are REQUIRED. Devices denoted with the triangle symbol may be omitted when stated elsewhere in the plans.
- See BC Standards for sign details.

*A shadow vehicle equipped with a Truck Mounted Attenuator is typically required. A shadow vehicle equipped with a TMA shall be used if it can be positioned 30' to 100' in advance of the area of crew exposure without adversely affecting the work performance.

Additional requirements for lane closures and advance signing shall be as shown on TCP (6-1) or as directed by the Engineer.



TRAFFIC CONTROL PLAN
WORK AREA AT EXIT RAMP

TCP (6-4)-12

FILE# 12266-4.dgn	DATE TxDOT	CHK TxDOT	DATE TxDOT	CHK TxDOT
© TxDOT	REVISED	REVISED	REVISED	REVISED
1-97 8-98	6378	54	001	SH 174, ETC
4-98 8-12	DIST	COUNTY	SHEET NO.	
	02	JOHNSON	32	

BARRICADE AND CONSTRUCTION (BC) STANDARD SHEETS GENERAL NOTES:

- The Barricade and Construction Standard Sheets (BC sheets) are intended to show typical examples for placement of temporary traffic control devices, construction pavement markings, and typical work zone signs. The information contained in these sheets meet or exceed the requirements shown in the "Texas Manual on Uniform Traffic Control Devices" (TMUTCD).
- The development and design of the Traffic Control Plan (TCP) is the responsibility of the Engineer.
- The Contractor may propose changes to the TCP that are signed and sealed by a licensed professional engineer for approval. The Engineer may develop, sign and seal Contractor proposed changes.
- The Contractor is responsible for installing and maintaining the traffic control devices as shown in the plans. The Contractor may not move or change the approximate location of any device without the approval of the Engineer.
- Geometric design of lane shifts and detours should, when possible, meet the applicable design criteria contained in manuals such as the American Association of State Highway and Transportation Officials (AASHTO), "A Policy on Geometric Design of Highways and Streets," the TxDOT "Roadway Design Manual" or engineering judgment.
- When projects abut, the Engineer(s) may omit the END ROAD WORK, TRAFFIC FINES DOUBLE, and other advance warning signs if the signing would be redundant and the work areas appear continuous to the motorists. If the adjacent project is completed first, the Contractor shall erect the necessary warning signs as shown on these sheets, the TCP sheets or as directed by the Engineer. The BEGIN ROAD WORK NEXT X MILES sign shall be revised to show appropriate work zone distance.
- The Engineer may require duplicate warning signs on the median side of divided highways where median width will permit and traffic volumes justify the signing.
- All signs shall be constructed in accordance with the details found in the "Standard Highway Sign Designs for Texas," latest edition. Sign details not shown in this manual shall be shown in the plans or the Engineer shall provide a detail to the Contractor before the sign is manufactured.
- The temporary traffic control devices shown in the illustrations of the BC sheets are examples. As necessary, the Engineer will determine the most appropriate traffic control devices to be used.
- As shown on BC(2), the OBEY WARNING SIGNS STATE LAW sign, STAY ALERT TALK OR TEXT LATER (see Sign Detail G20-10T) and the WORK ZONE TRAFFIC FINES DOUBLE sign with plaque shall be erected in advance of the CSJ limits. However, the TRAFFIC FINES DOUBLE sign will not be required on projects consisting solely of mobile operation work, such as striping or milling edgeline rumble strips. The BEGIN ROAD WORK NEXT X MILES, CONTRACTOR and END ROAD WORK signs shall be erected at or near the CSJ limits.
- Except for devices required by Note 10, traffic control devices should be in place only while work is actually in progress or a definite need exists.
- The Engineer has the final decision on the location of all traffic control devices.
- Inactive equipment and work vehicles, including workers' private vehicles must be parked away from travel lanes. They should be as close to the right-of-way line as possible, or located behind a barrier or guardrail, or as approved by the Engineer.

WORKER SAFETY APPAREL NOTES:

- Workers on foot who are exposed to traffic or to construction equipment within the right-of-way shall wear high-visibility safety apparel meeting the requirements of ISEA "American National Standard for High-Visibility Apparel," or equivalent revisions, and labeled as ANSI 107-2004 standard performance for Class 2 or 3 risk exposure. Class 3 garments should be considered for high traffic volume work areas or night time work.

DISCLAIMER: The use of this standard is governed by the "Texas Engineering Practice Act". No warranty of any kind is made by TxDOT for any purpose whatsoever. TxDOT assumes no responsibility for the conversion of this standard to other formats or for incorrect results or damages resulting from its use.

DATE: FILE:

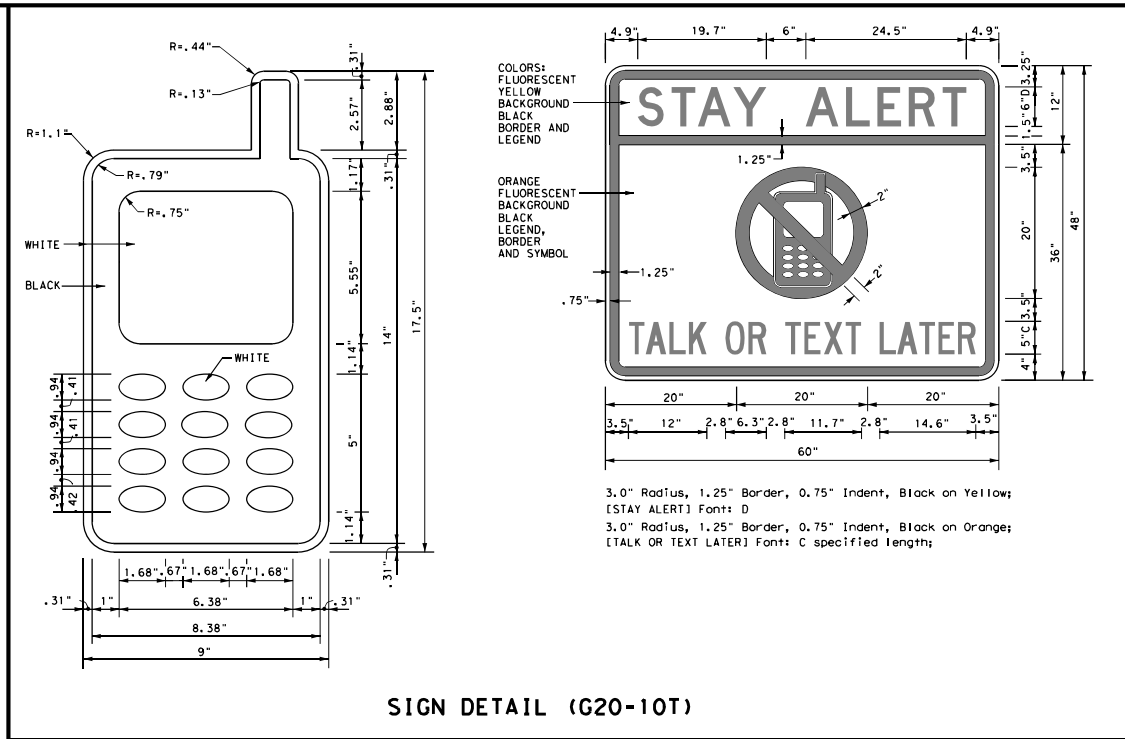

Only pre-qualified products shall be used. The "Compliant Work Zone Traffic Control Devices List" (CWZTCD) describes pre-qualified products and their sources and may be found on-line at the web address given below or by contacting:

Texas Department of Transportation
 Traffic Operations Division - TE
 Phone (512) 416-3118

THE DOCUMENTS BELOW CAN BE FOUND ON-LINE AT
<http://www.txdot.gov>

COMPLIANT WORK ZONE TRAFFIC CONTROL DEVICES LIST (CWZTCD)
DEPARTMENTAL MATERIAL SPECIFICATIONS (DMS)
MATERIAL PRODUCER LIST (MPL)
ROADWAY DESIGN MANUAL - SEE "MANUALS (ONLINE MANUALS)"
STANDARD HIGHWAY SIGN DESIGNS FOR TEXAS (SHSD)
TEXAS MANUAL ON UNIFORM TRAFFIC CONTROL DEVICES (TMUTCD)
TRAFFIC ENGINEERING STANDARD SHEETS

SHEET 1 OF 12

		Traffic Operations Division Standard	
BARRICADE AND CONSTRUCTION GENERAL NOTES AND REQUIREMENTS			
BC (1) - 14			
Files: bc-14.dgn 4-03 5-10 6-14 9-07 REVISIONS: 6379 54 001 0151 02	DATE: November 2002 6379 54 001 0151 02	JOB: SH 174, ETC COMPANY: JOHNSON	SHEET NO.: 33

DISCLAIMER: This standard is governed by the "Texas Engineering Practice Act". No warranty of any kind is made by TxDOT for any purpose whatsoever. TxDOT assumes no responsibility for the conversion of this standard to other formats or for incorrect results or damages resulting from its use.

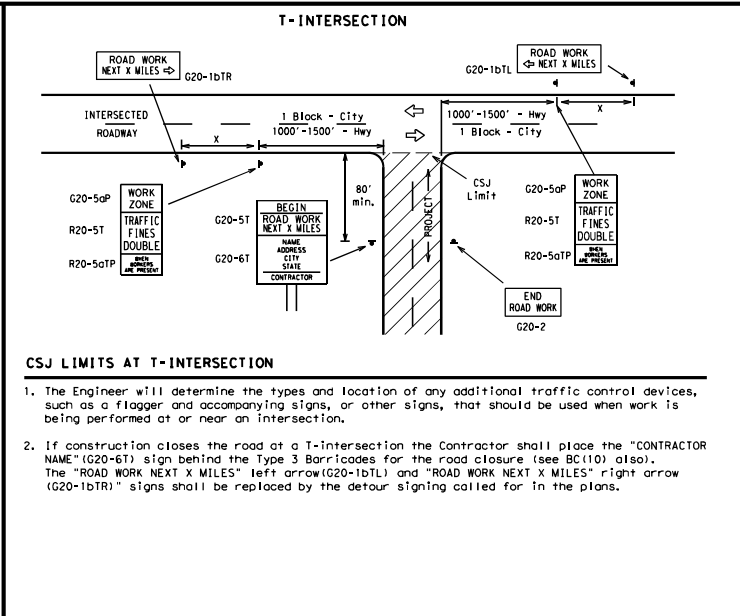
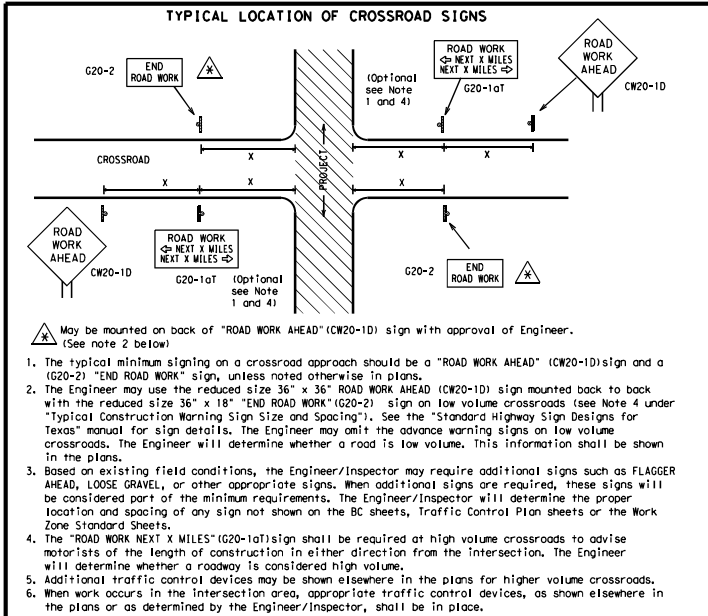

TYPICAL CONSTRUCTION WARNING SIGN SIZE AND SPACING^{15,6}

Sign Number or Series	SIZE		SPACING	
	Conventional Road	Expressway/Freeway	Posted Speed MPH	Sign Spacing "X" Feet (Approx.)
CW20 ⁴	48" x 48"	48" x 48"	30	120
CW21			35	160
CW22			40	240
CW23			45	320
CW1, CW2, CW7, CW8, CW9, CW11, CW14	36" x 36"	48" x 48"	50	400
			55	500 ²
			60	600 ²
			65	700 ²
CW3, CW4, CW5, CW6, CW8-3, CW10, CW12	48" x 48"	48" x 48"	70	800 ²
			75	900 ²
			80	1000 ²
			*	* ³

* For typical sign spacings on divided highways, expressways and freeways, see Part 6 of the "Texas Manual on Uniform Traffic Control Devices" (TMUTCD) typical application diagrams or TCP Standard Sheets.

¹ Minimum distance from work area to first Advance Warning sign nearest the work area and/or distance between each additional sign.

GENERAL NOTES

- Special or larger size signs may be used as necessary.
- Distance between signs should be increased as required to have 1500 feet advance warning.
- Distance between signs should be increased as required to have 1/2 mile or more advance warning.
- 36" x 36" "ROAD WORK AHEAD" (CW20-10) signs may be used on low volume crossroads at the discretion of the Engineer. See Note 2 under "Typical Location of Crossroad Signs".
- Only diamond shaped warning sign sizes are indicated.
- See sign size listing in "TMUTCD", Sign Appendix or the "Standard Highway Sign Designs for Texas" manual for complete list of available sign design sizes.

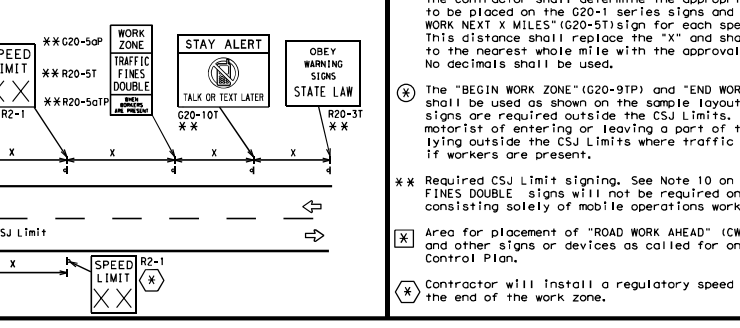
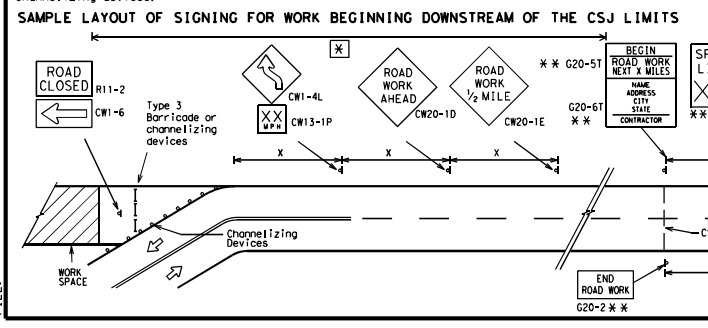
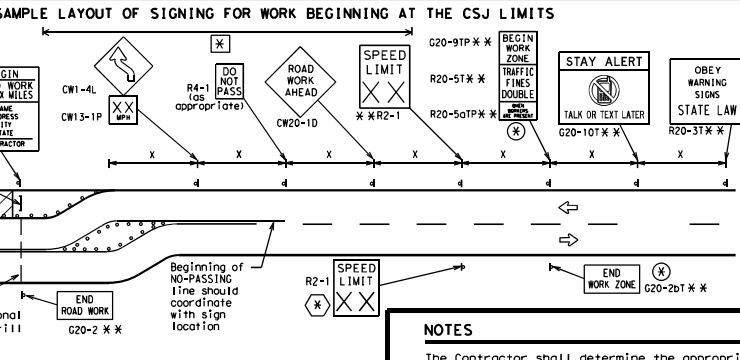
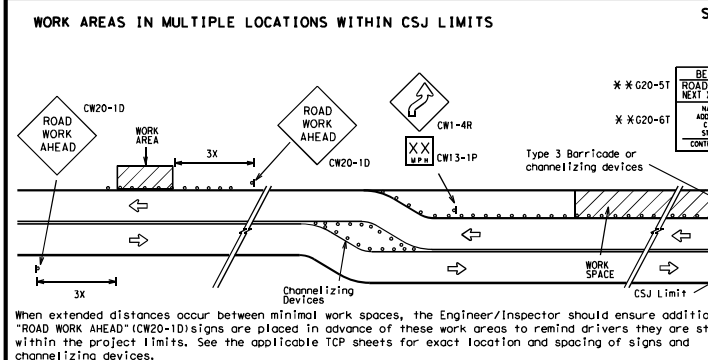

LEGEND

	Type 3 Barricade
	Channelizing Devices
	Sign
X	See Typical Construction Warning Sign Size and Spacing chart or the TMUTCD for sign spacing requirements.

SHEET 2 OF 12

BARRICADE AND CONSTRUCTION PROJECT LIMIT

BC (2) - 14

FILE: dc-14.dgn	DN: TxDOT	CK: TxDOT	DM: TxDOT	CK: TxDOT
© TxDOT November 2002	CONT: 6379	SECT: 54	JOB: 001	HIGHWAY: SH 174, ETC
REVISIONS	DATE: 9-07	BY: 8-14	DIST: 02	COUNTY: JOHNSON
	DATE: 7-13			SHEET NO.: 34

Texas Department of Transportation
Traffic Operations Division Standard

DATE: FILE:

TYPICAL APPLICATION OF WORK ZONE SPEED LIMIT SIGNS

Work zone speed limits shall be regulatory, established in accordance with the "Procedures for Establishing Speed Zones," and approved by the Texas Transportation Commission, or by City Ordinance when within Incorporated City Limits.

Reduced speeds should only be posted in the vicinity of work activity and not throughout the entire project.

Regulatory work zone speed signs (R2-1) shall be removed or covered during periods when they are not needed.

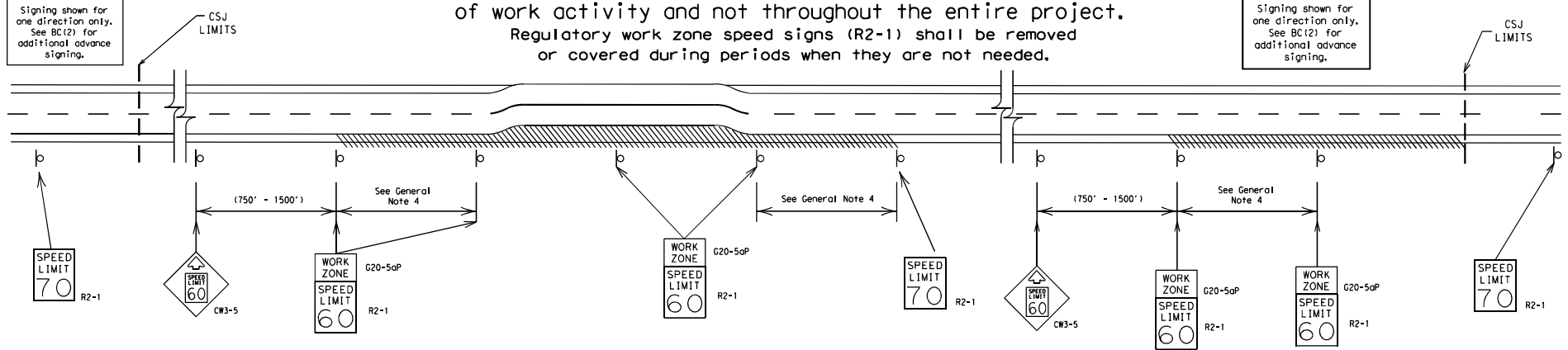

GUIDANCE FOR USE:

LONG/INTERMEDIATE TERM WORK ZONE SPEED LIMITS

This type of work zone speed limit should be included on the design of the traffic control plans when restricted geometrics with a lower design speed are present in the work zone and modification of the geometrics to a higher design speed is not feasible.

Long/Intermediate Term Work Zone Speed Limit signs, when approved as described above, should be posted and visible to the motorist when work activity is present.

Work activity may also be defined as a change in the roadway that requires a reduced speed for motorists to safely negotiate the work area, including:

- a) rough road or damaged pavement surface
- b) substantial alteration of roadway geometrics (diversions)
- c) construction detours
- d) grade
- e) width
- f) other conditions readily apparent to the driver

As long as any of these conditions exist, the work zone speed limit signs should remain in place.

SHORT TERM WORK ZONE SPEED LIMITS

This type of work zone speed limit may be included on the design of the traffic control plans when workers or equipment are not behind concrete barrier, when work activity is within 10 feet of the traveled way or actually in the travelled way.

Short Term Work Zone Speed Limit signs should be posted and visible to the motorists only when work activity is present. When work activity is not present, signs shall be removed or covered. (See Removing or Covering on BC(4)).

GENERAL NOTES

1. Regulatory work zone speed limits should be used only for sections of construction projects where speed control is of major importance.
2. Regulatory work zone speed limit signs shall be placed on supports at a 7 foot minimum mounting height.
3. Speed zone signs are illustrated for one direction of travel and are normally posted for each direction of travel.
4. Frequency of work zone speed limit signs should be:
 - 40 mph and greater 0.2 to 2 miles
 - 35 mph and less 0.2 to 1 mile
5. Regulatory speed limit signs shall have black legend and border on a white reflective background (See "Reflective Sheeting" on BC(4)).
6. Fabrication, erection and maintenance of the "ADVANCE SPEED LIMIT" (CW3-5) sign, "WORK ZONE" (G20-5aP) plaque and the "SPEED LIMIT" (R2-1) signs shall not be paid for directly, but shall be considered subsidiary to Item 502.
7. Turning signs from view, laying signs over or down will not be allowed, unless as otherwise noted under "REMOVING OR COVERING" on BC(4).
8. Techniques that may help reduce traffic speeds include but are not limited to:
 - A. Law enforcement.
 - B. Flagger stationed next to sign.
 - C. Portable changeable message sign (PCMS).
 - D. Low-power (drone) radar transmitter.
 - E. Speed monitor trailers or signs.
9. Speeds shown on details above are for illustration only. Work Zone Speed Limits should only be posted as approved for each project.
10. For more specific guidance concerning the type of work, work zone conditions and factors impacting allowable regulatory construction speed zone reduction see TxDOT form #1204 in the TxDOT e-form system.

SHEET 3 OF 12



BARRICADE AND CONSTRUCTION WORK ZONE SPEED LIMIT

BC (3) - 14

File#:	bc-14.dgn	Drawn by:	TxDOT	Checked by:	TxDOT	Drawn by:	TxDOT	Checked by:	TxDOT
©	TxDOT	November	2002	CONT	SECT	JOB	HIGHWAY		
REVISONS		6379	54	001	SH	174, ETC			
9-07	8-14	DIST	COUNTY	SHEET NO.					
7-13		02	JOHNSON	35					

DISCLAIMER: The use of this standard is governed by the "Texas Engineering Practice Act". No warranty of any kind is made by TxDOT for any purpose whatsoever. TxDOT assumes no responsibility for the conversation of this standard to other formats or for incorrect results or damages resulting from its use.

DATE:
FILE:

TYPICAL MINIMUM CLEARANCES FOR LONG TERM AND INTERMEDIATE TERM SIGNS

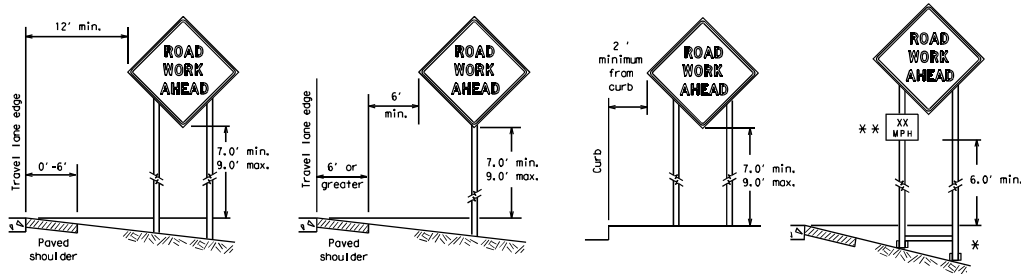

* When placing skid supports on uneven ground, the leg post lengths must be adjusted so the sign appears straight and plumb. Objects shall NOT be placed under skids as a means of leveling.

** When plaques are placed on dual-leg supports, they should be attached to the upright nearest the travel lane. Supplemental plaques (advisory or distance) should not cover the surface of the parent sign.

ATTACHMENT FOR SIGN SUPPORTS

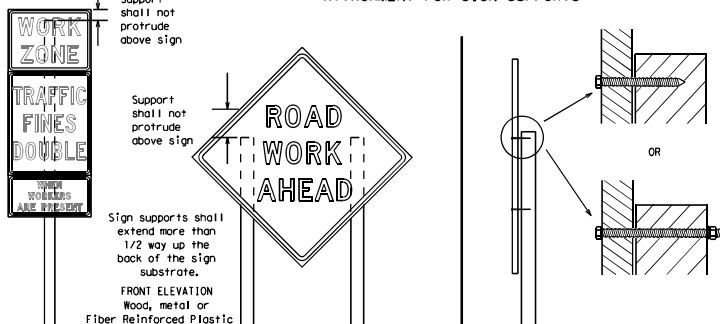

Attachment to wooden supports will be by bolts and nuts or screws. Use TXDOT's or manufacturer's recommended procedures for attaching sign substrates to other types of sign supports

Nails shall NOT be allowed. Each sign shall be attached directly to the sign support. Multiple signs shall not be joined or spliced by any means. Wood supports shall not be extended or repaired by splicing or other means.

DISCLAIMER: The use of this standard is governed by the "Texas Engineering Practice Act". No warranty of any kind is made by TXDOT for any purpose whatsoever. TXDOT assumes no responsibility for the conversion of this standard to other formats or for inaccurate results or damage resulting from its use.

GENERAL NOTES FOR WORK ZONE SIGNS

- Contractor shall install and maintain signs in a straight and plumb condition and/or as directed by the Engineer.
- Wooden sign posts shall be painted white.
- Barricades shall NOT be used as sign supports.
- All signs shall be installed in accordance with the plans or as directed by the Engineer. Signs shall be used to regulate, warn, and guide the traveling public safely through the work zone.
- The Contractor may furnish either the sign design shown in the plans or in the "Standard Highway Sign Designs for Texas" (SHSD). The Engineer/Inspector may require the Contractor to furnish other work zone signs that are shown in the TMUTCD but may have been omitted from the plans. Any variation in the plans shall be documented by written agreement between the Engineer and the Contractor's Responsible Person. All changes must be documented in writing before being implemented. This can include documenting the changes in the Inspector's TXDOT diary and having both the Inspector and Contractor initial and date the agreed upon changes.
- The Contractor shall furnish sign supports listed in the "Compliant Work Zone Traffic Control Device List" (CWZTCD). The Contractor shall install the sign support in accordance with the manufacturer's recommendations. If there is a question regarding installation procedures, the Contractor shall furnish the Engineer a copy of the manufacturer's installation recommendations so the Engineer can verify the correct procedures are being followed.
- The Contractor is responsible for installing signs on approved supports and replacing signs with damaged or cracked substrates and/or damaged or marred reflective sheeting as directed by the Engineer/Inspector.
- Identification markings may be shown only on the back of the sign substrate. The maximum height of letters and/or company logos used for identification shall be 1 inch.
- The Contractor shall replace damaged wood posts. New or damaged wood sign posts shall not be spliced.

DURATION OF WORK (as defined by the "Texas Manual on Uniform Traffic Control Devices" Part 6)

- The types of sign supports, sign mounting height, the size of signs, and the type of sign substrates can vary based on the type of work being performed. The Engineer is responsible for selecting the appropriate size sign for the type of work being performed. The Contractor is responsible for ensuring the sign support, sign mounting height and substrate meets manufacturer's recommendations in regard to crashworthiness and duration of work requirements.
 - Long-term stationary - work that occupies a location more than 3 days.
 - Intermediate-term stationary - work that occupies a location more than one daylight period up to 3 days, or nighttime work lasting more than one hour.
 - Short-term stationary - daytime work that occupies a location for more than 1 hour in a single daylight period.
 - Short, duration - work that occupies a location up to 1 hour.
 - Mobile - work that moves continuously or intermittently (stopping for up to approximately 15 minutes.)

SIGN MOUNTING HEIGHT

- The bottom of Long-term/Intermediate-term signs shall be at least 7 feet, but not more than 9 feet, above the paved surface, except as shown for supplemental plaques mounted below other signs.
- The bottom of Short-term/Short Duration signs shall be a minimum of 1 foot above the pavement surface but no more than 2 feet above the ground.
- Long-term/Intermediate-term Signs may be used in lieu of Short-term/Short Duration signing.
- Short-term/Short Duration signs shall be used only during daylight and shall be removed at the end of the workday or raised to appropriate Long-term/Intermediate sign height.
- Regulatory signs shall be mounted at least 7 feet, but not more than 9 feet, above the paved surface regardless of work duration.

SIZE OF SIGNS

- The Contractor shall furnish the sign sizes shown on BC (2) unless otherwise shown in the plans or as directed by the Engineer.

SIGN SUBSTRATES

- The Contractor shall ensure the sign substrate is installed in accordance with the manufacturer's recommendations for the type of sign support that is being used. The CWZTCD lists each substrate that can be used on the different types and models of sign supports.
- "Mesh" type materials are NOT an approved sign substrate, regardless of the tightness of the weave.
- All wooden individual sign panels fabricated from 2 or more pieces shall have one or more plywood cleat, 1/2" thick by 6" wide, fastened to the back of the sign and extending fully across the sign. The cleat shall be attached to the back of the sign using wood screws that do not penetrate the face of the sign panel. The screws shall be placed on both sides of the splice and spaced at 6" centers. The Engineer may approve other methods of splicing the sign face.

REFLECTIVE SHEETING

- All signs shall be retroreflective and constructed of sheeting meeting the color and retro-reflectivity requirements of DMS-8300 or rigid signs or DMS-8310 for roll-up signs. The web address for DMS specifications is shown on BC(1).
- White sheeting, meeting the requirements of DMS-8300 Type A, shall be used for signs with a white background.
- Orange sheeting, meeting the requirements of DMS-8300 Type B_L or Type C_L, shall be used for rigid signs with orange backgrounds.

SIGN LETTERS

- All sign letters and numbers shall be clear, and open rounded type uppercase alphabet letters as approved by the Federal Highway Administration (FHWA) and as published in the "Standard Highway Sign Design for Texas" manual. Signs, letters and numbers shall be of first class workmanship in accordance with Department Standards and Specifications.

REMOVING OR COVERING

- When sign messages may be confusing or do not apply, the signs shall be removed or completely covered.
- Long-term stationary or intermediate stationary signs installed on square metal tubing may be turned away from traffic 90 degrees when the sign message is not applicable. This technique may not be used for signs installed in the median of divided highways or near any intersections where the sign may be seen from approaching traffic.
- Signs installed on wooden skids shall not be turned at 90 degree angles to the roadway. These signs should be removed or completely covered when not required.
- When signs are covered, the material used shall be opaque, such as heavy mil black plastic, or other materials which will cover the entire sign face and maintain their opaque properties under automobile headlights at night, without damaging the sign sheeting.
- Burlap shall NOT be used to cover signs.
- Duct tape or other adhesive material shall NOT be affixed to a sign face.
- Signs and anchor stubs shall be removed and holes backfilled upon completion of work.

SIGN SUPPORT WEIGHTS

- Where sign supports require the use of weights to keep from turning over, the use of sandbags with dry, cohesionless sand should be used.
- The sandbags will be filled shut to keep the sand from spilling and to maintain a constant weight.
- Rock, concrete, iron, steel or other solid objects shall not be permitted for use as sign support weights.
- Sandbags should weigh a minimum of 35 lbs and a maximum of 50 lbs.
- Sandbags shall be made of durable material that tears upon vehicular impact. Rubber (such as fire inner tubes) shall NOT be used.
- Rubber ballasts designed for channelizing devices should not be used for ballast on portable sign supports. Sign supports designed and manufactured with rubber bases may be used when shown on the CWZTCD list.
- Sandbags shall only be placed along or laid over the base supports of the traffic control device and shall not be suspended above ground level or hung with rope, wire, chains or other fasteners. Sandbags shall be placed along the length of the skids to weigh down the sign support.
- Sandbags shall NOT be placed under the skid and shall not be used to level sign supports placed on slopes.

FLAGS ON SIGNS

- Flags may be used to draw attention to warning signs. When used the flag shall be 16 inches square or larger and shall be orange or fluorescent red-orange in color. Flags shall not be allowed to cover any portion of the sign face.

STOP/SLOW PADDLES

- STOP/SLOW paddles are the primary method to control traffic by flaggers. The STOP/SLOW paddle size should be 24" x 24" as detailed below.
- When used at night, the STOP/SLOW paddle shall be retroreflectORIZED.
- STOP/SLOW paddles may be attached to a staff with a minimum length of 6' to the bottom of the sign.
- Any lights incorporated into the STOP or SLOW paddle faces shall only be as specifically described in Section 6E.03 Hand Signaling Devices in the TMUTCD.

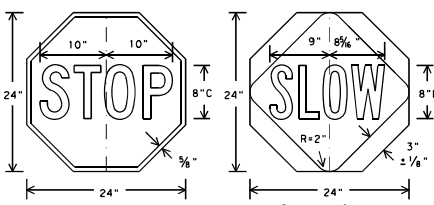

CONTRACTOR REQUIREMENTS FOR MAINTAINING PERMANENT SIGNS WITHIN THE PROJECT LIMITS

- Permanent signs are used to give notice of traffic laws or regulations, call attention to conditions that are potentially hazardous to traffic operations, show route designations, destinations, directions, distances, services, points of interest, and other geographical, recreational, or cultural information. Drivers proceeding through a work zone need the same, if not better route guidance as normally installed on a roadway without construction.
- When permanent regulatory or warning signs conflict with work zone conditions, remove or cover the permanent signs until the permanent sign message matches the roadway condition.
- When existing permanent signs are moved and relocated due to construction purposes, they shall be visible to motorists at all times.
- If existing signs are to be relocated on their original supports, they shall be installed on crashworthy bases as shown on the BC Sheets or the SMD Standards. This work should be paid for under the appropriate pay item for relocating existing signs.
- If permanent signs are to be removed and relocated using temporary supports, the Contractor shall use crashworthy supports as shown on the BC sheets or the CWZTCD. The signs shall meet the required mounting heights shown on the BC Sheets or the SMD Standards during construction. This work should be paid for under the appropriate pay item for relocating existing signs.
- Any sign or traffic control device that is struck or damaged by the Contractor or his/her construction equipment shall be replaced as soon as possible by the Contractor to ensure proper guidance for the motorists. This will be subsidiary to Item 502.



BARRICADE AND CONSTRUCTION TEMPORARY SIGN NOTES

BC (4) - 14

FILE:	bc+14.dgn	REV:	TXDOT	CHK:	TXDOT	DES:	TXDOT	CR:	TXDOT
DATE:	November 2002	QNTY:	321	QNTY:	321	QNTY:	321	QNTY:	321
REV:	8-14	QNTY:	54	QNTY:	54	QNTY:	54	QNTY:	54
REV:	7-13	QNTY:	02	QNTY:	02	QNTY:	02	QNTY:	02
		QNTY:	JOHNSON	QNTY:	JOHNSON	QNTY:	JOHNSON	QNTY:	JOHNSON
		QNTY:	36	QNTY:	36	QNTY:	36	QNTY:	36

DISCLAIMER: This drawing is approved by the Texas Engineering Practices Act. No warranty of any kind is made by TxDOT for any purpose whatsoever. TxDOT assumes no responsibility for the conversion of this standard to other formats or for incorrect results or damages resulting from its use.

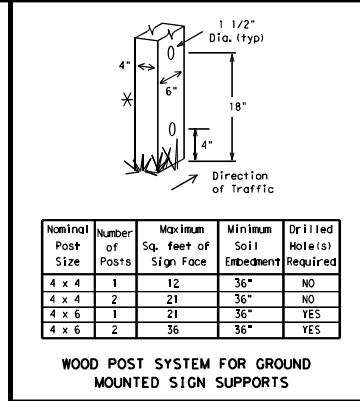
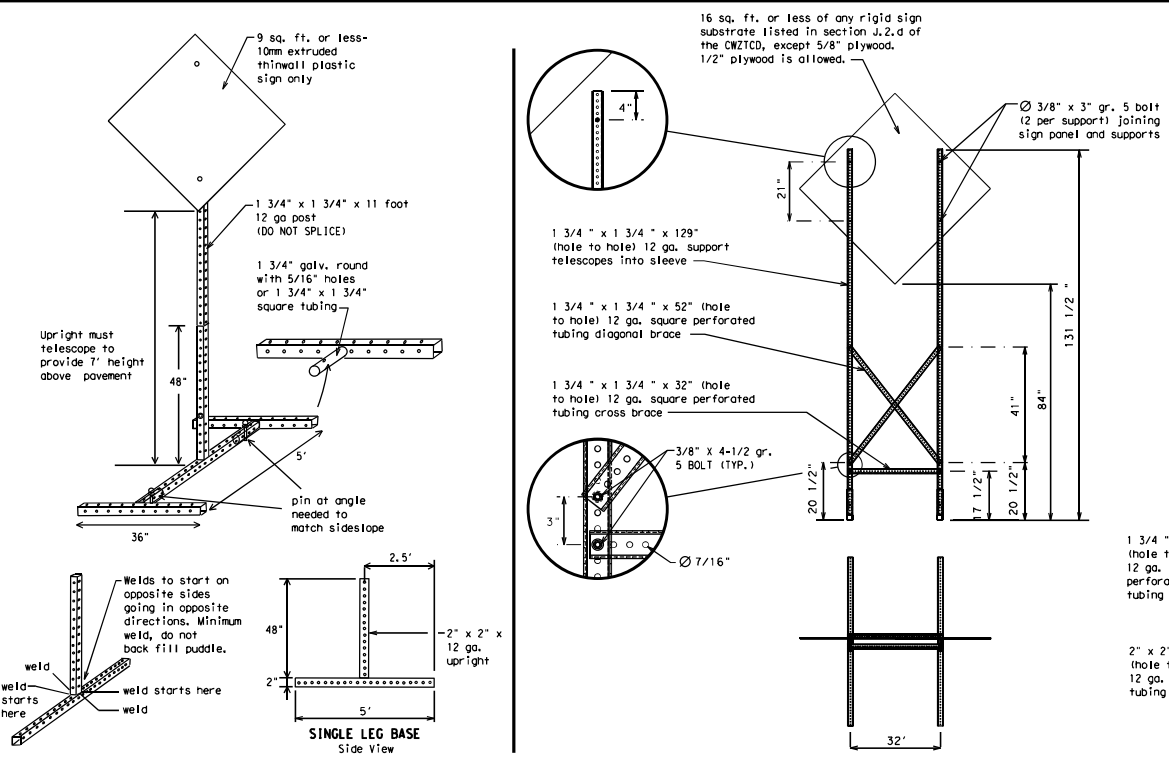
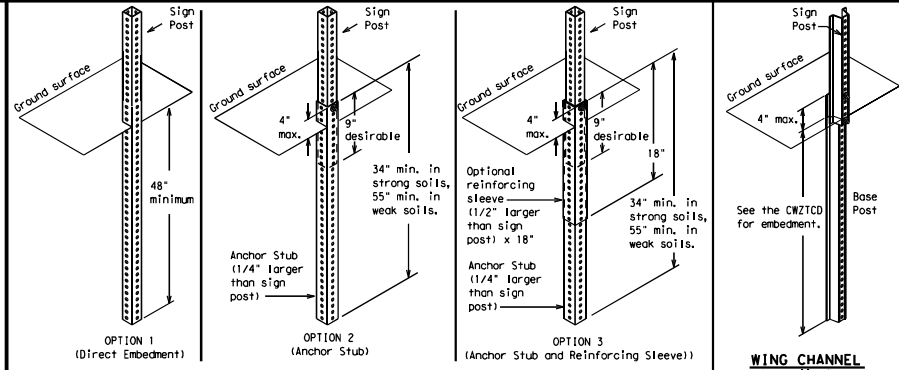
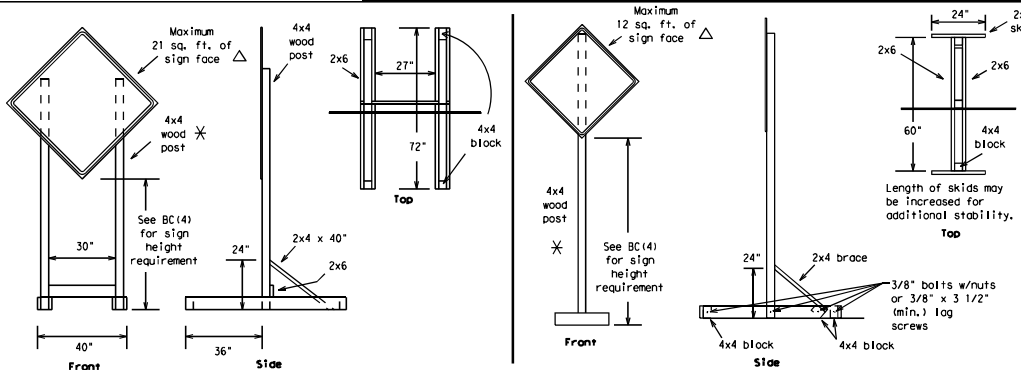

WEDGE ANCHORS
 Both steel and plastic Wedge Anchor Systems as shown on the SMD Standard Sheets may be used as temporary sign supports for signs up to 10 square feet of sign face. They may be set in concrete or in sturdy soils if approved by the Engineer. (See web address for "Traffic Engineering Standard Sheets" on BC(1)).

OTHER DESIGNS
 MORE DETAILS OF APPROVED LONG/INTERMEDIATE AND SHORT TERM SUPPORTS CAN BE FOUND ON THE CWZTCD LIST. SEE BC(1) FOR WEBSITE LOCATION.

GENERAL NOTES

- Nails may be used in the assembly of wooden sign supports, but 3/8" bolts with nuts or 3/8" x 3 1/2" lag screws must be used on every joint for final connection.
- No more than 2 sign posts shall be placed within a 7 ft. circle, except for specific materials noted on the CWZTCD List.
- When project is completed, all sign supports and foundations shall be removed from the project site. This will be considered subsidiary to item 502.

□ See BC(4) for definition of "Work Duration."
 ✖ Wood sign posts MUST be one piece. Splicing will NOT be allowed. Posts shall be painted white.
 Δ See the CWZTCD for the type of sign substrate that can be used for each approved sign support.

SHEET 5 OF 12

 Texas Department of Transportation
 Traffic Operations Division Standard

BARRICADE AND CONSTRUCTION TYPICAL SIGN SUPPORT

BC (5) - 14

FILE: bc-14.dgn	DN: TxDOT	CK: TxDOT	DW: TxDOT	CR: TxDOT
© TxDOT November 2002	CONT	SECT	JOB	HIGHWAY
REVISIONS	6379	54	001	SH 174, ETC
9-07	8-14	DIST	COUNTY	SHEET NO.
7-13		02	JOHNSON	37

DATE:
 FILE:

WHEN NOT IN USE, REMOVE THE PCMS FROM THE RIGHT-OF-WAY OR PLACE THE PCMS BEHIND BARRIER OR GUARDRAIL WITH SIGN PANEL TURNED PARALLEL TO TRAFFIC

RECOMMENDED PHASES AND FORMATS FOR PCMS MESSAGES DURING ROADWORK ACTIVITIES

(The Engineer may approve other messages not specifically covered here.)

PORTABLE CHANGEABLE MESSAGE SIGNS

- The Engineer/Inspector shall approve all messages used on portable changeable message signs (PCMS).
- Messages on PCMS should contain no more than 8 words (about four to eight characters per word), not including simple words such as "TO," "FOR," "AT," etc.
- Messages should consist of a single phase, or two phases that alternate. Three-phase messages are not allowed. Each phase of the message should convey a single thought, and must be understood by itself.
- Use the word "EXIT" to refer to an exit ramp on a freeway; i.e., "EXIT CLOSED." Do not use the term "RAMP."
- Always use the route or interstate designation (IH, US, SH, FM) along with the number when referring to a roadway.
- When in use the bottom of a stationary PCMS message panel should be a minimum 7 feet above the roadway, where possible.
- The message term "WEEKEND" should be used only if the work is to start on Saturday morning and end by Sunday evening at midnight. Actual days and hours of work should be displayed on the PCMS if work is to begin on Friday evening and/or continue into Monday morning.
- The Engineer/Inspector may select one of two options which are available for displaying a two-phase message on a PCMS. Each phase may be displayed for either four seconds each or for three seconds each.
- Do not "flash" messages or words included in a message. The message should be steady burn or continuous while displayed.
- Do not present redundant information on a two-phase message; i.e., keeping two lines of the message the same and changing the third line.
- Do not use the word "Danger" in message.
- Do not display the message "LANES SHIFT LEFT" or "LANES SHIFT RIGHT" on a PCMS. Drivers do not understand the message.
- Do not display messages that scroll horizontally or vertically across the face of the sign.
- The following table lists abbreviated words and two-word phrases that are acceptable for use on a PCMS. Both words in a phrase must be displayed together. Words or phrases not on this list should not be abbreviated, unless shown in the "MUTCD."
- PCMS character height should be at least 18 inches for trailer mounted units. They should be visible from at least 1/2 (.5) mile and the text should be legible from at least 600 feet at night and 800 feet in daylight. Truck mounted units must have a character height of 10 inches and must be legible from at least 400 feet.
- Each line of text should be centered on the message board rather than left or right justified.
- If disabled, the PCMS should default to an illegible display that will not alarm motorists and will only be used to alert workers that the PCMS has malfunctioned. A pattern such as a series of horizontal solid bars is appropriate.

Phase 1: Condition Lists

Road/Lane/Ramp Closure List

FREEWAY CLOSED X MILE	FRONTAGE ROAD CLOSED
ROAD CLOSED AT SH XXX	SHOULDER CLOSED XXX FT
ROAD CLSD AT FM XXXX	RIGHT LN CLOSED XXX FT
RIGHT X LANES CLOSED	RIGHT X LANES OPEN
CENTER LANE CLOSED	DAYTIME LANE CLOSURES
NIGHT LANE CLOSURES	I-XX SOUTH EXIT CLOSED
VARIOUS LANES CLOSED	EXIT XXX CLOSED X MILE
EXIT CLOSED	RIGHT LN TO BE CLOSED
MALL DRIVEWAY CLOSED	X LANES CLOSED TUE - FRI
XXXXXXX BLVD CLOSED	

Other Condition List

ROADWORK XXX FT	ROAD REPAIRS XXXX FT
FLAGGER XXXX FT	LANE NARROWS XXXX FT
RIGHT LN XXXX FT	TWO-WAY TRAFFIC XX MILE
MERGING TRAFFIC XXXX FT	CONST TRAFFIC XXX FT
LOOSE GRAVE XXXX FT	UNEVEN LANES XXXX FT
DETOUR X MILE	ROUGH ROAD XXXX FT
ROADWORK PAST SH XXXX	ROADWORK NEXT FRI-SUN
BUMP XXXX FT	US XXX EXIT X MILES
TRAFFIC SIGNAL XXXX FT	LANES SHIFT *

* LANES SHIFT in Phase 1 must be used with STAY IN LANE in Phase 2.

Phase 2: Possible Component Lists

Action to Take/Effect on Travel List

MERGE RIGHT	FORM X LINES RIGHT
DETOUR NEXT X EXITS	USE XXXXX RD EXIT
USE EXIT XXX	USE EXIT I-XX NORTH
STAY ON US XXX SOUTH	USE I-XX E TO I-XX N
TRUCKS USE US XXX N	WATCH FOR TRUCKS
WATCH FOR TRUCKS	EXPECT DELAYS
EXPECT DELAYS	PREPARE TO STOP
REDUCE SPEED XXX FT	END SHOULDER USE
USE OTHER ROUTES	WATCH FOR WORKERS
STAY IN LANE *	

Location List

AT FM XXXX
BEFORE RAILROAD CROSSING
NEXT X MILES
PAST US XXX EXIT
XXXXXXXX TO XXXXXXXX
US XXX TO FM XXXX

Warning List

SPEED LIMIT XX MPH
MAXIMUM SPEED XX MPH
MINIMUM SPEED XX MPH
ADVISORY SPEED XX MPH
RIGHT LANE EXIT
USE CAUTION
DRIVE SAFELY
DRIVE WITH CARE

** Advance Notice List

TUE-FRI XX AM- X PM
APR XX- XX X PM-X AM
BEGINS MONDAY
BEGINS MAY XX
MAY X-X XX PM - XX AM
NEXT FRI-SUN
XX AM TO XX PM
NEXT TUE AUG XX
TONIGHT XX PM- XX AM

** See Application Guidelines Note 6.

APPLICATION GUIDELINES

- Only 1 or 2 phases are to be used on a PCMS.
- The 1st phase (or both) should be selected from the "Road/Lane/Ramp Closure List" and the "Other Condition List".
- A 2nd phase can be selected from the "Action to Take/Effect on Travel, Location, General Warning, or Advance Notice Phase Lists".
- A Location Phase is necessary only if a distance or location is not included in the first phase selected.
- If two PCMS are used in sequence, they must be separated by a minimum of 1000 ft. Each PCMS shall be limited to two phases, and should be understandable by themselves.
- For advance notice, when the current date is within seven days of the actual work date, calendar days should be replaced with days of the week. Advance notification should typically be for no more than one week prior to the work.

WORDING ALTERNATIVES

- The words RIGHT, LEFT and ALL can be interchanged as appropriate.
- Roadway designations IH, US, SH, FM and LP can be interchanged as appropriate.
- EAST, WEST, NORTH and SOUTH (or abbreviations E, W, N and S) can be interchanged as appropriate.
- Highway names and numbers replaced as appropriate.
- ROAD, HIGHWAY and FREEWAY can be interchanged as needed.
- AHEAD may be used instead of distances if necessary.
- FT and MI, MILE and MILES interchanged as appropriate.
- AT, BEFORE and PAST interchanged as needed.
- Distances or AHEAD can be eliminated from the message if a location phase is used.

SHEET 6 OF 12

PCMS SIGNS WITHIN THE R.O.W. SHALL BE BEHIND GUARDRAIL OR CONCRETE BARRIER OR SHALL HAVE A MINIMUM OF FOUR (4) PLASTIC DRUMS PLACED PERPENDICULAR TO TRAFFIC ON THE UPSTREAM SIDE OF THE PCMS, WHEN EXPOSED TO ONE DIRECTION OF TRAFFIC. WHEN EXPOSED TO TWO WAY TRAFFIC, THE FOUR DRUMS SHOULD BE PLACED WITH ONE DRUM AT EACH OF THE FOUR CORNERS OF THE UNIT.

FULL MATRIX PCMS SIGNS

- When Full Matrix PCMS signs are used, the character height and legibility/visibility requirements shall be maintained as listed in Note 15 under "PORTABLE CHANGEABLE MESSAGE SIGNS" above.
- When symbol signs, such as the "Flagger Symbol" (CW20-7) are represented graphically on the Full Matrix PCMS sign and, with the approval of the Engineer, it shall maintain the legibility/visibility requirement listed above.
- When symbol signs are represented graphically on the Full Matrix PCMS, they shall only supplement the use of the static sign represented, and shall not substitute for, or replace that sign.
- A Full Matrix PCMS may be used to simulate a flashing arrow board provided it meets the visibility, flash rate and dimming requirements on BC(7), for the same size arrow.

DISCLAIMER: The use of this standard is governed by the "Texas Engineering Practice Act". No warranty of any kind is made by TxDOT for any purpose whatsoever. TxDOT assumes no responsibility for the conversion of this standard to other formats or for incorrect results or damages resulting from its use.

DATE: FILE:

WORD OR PHRASE	ABBREVIATION	WORD OR PHRASE	ABBREVIATION
Access Road	ACCS RD	Major	MAJ
Alternate	ALT	Miles	MI
Avenue	AVE	Miles Per Hour	MPH
Best Route	BEST RTE	Minor	MIN
Boulevard	BLVD	Monday	MON
Bridge	BRDG	North	NORTH
Cannot	CANT	North	N
Center	CTR	Northbound (route) N	
Construction Ahead	CONST AHD	Parking	PKING
CROSSING	XING	Road	RD
Detour Route	DETOUR RTE	Right Lane	RT LN
Do Not	DNOT	Saturday	SAT
East	E	Service Road	SERV RD
Eastbound (route) E		Shoulder	SHLDR
Emergency	EMER	Slippery	SLIP
Emergency Vehicle	EMER VEH	South	S
Entrance, Enter	ENT	Southbound (route) S	
Express Lane	EXP LN	Speed	SPD
Expressway	EXPWY	Street	ST
XXXX Feet	XXXX FT	Sunday	SUN
FOC Ahead	FOC AHD	Telephone	PHONE
Freeway	FRWY, FWY	Temporary	TEMP
Freeway Blocked	FWY BLKD	Thursday	THURS
Friday	FRI	To Downtown	TO DOWNTN
Hazardous Driving	HAZ DRIVING	Traffic	TRAF
Hazardous Material	HAZMAT	Travelers	TRVLRS
High-Occupancy	HOV	Tuesday	TUES
Vehicle	VEH	Time Minutes	TIME MIN
Highway	Hwy	Upper Level	UPR LEVEL
Hour (s)	HR, HRS	Vehicles (s)	VEH, VEHs
Information	INFO	Warning	WARN
ITS	ITS	Wednesday	WED
Junction	JCT	Weight Limit	WT LMIT
Left	LFT	West	W
Left Lane	LFT LN	Westbound (route) W	
Lane Closed	LN CLOSED	Wet Pavement	WET PVMT
Lower Level	LRW LEVEL	Will Not	WONT
Maintenance	MAINT		

Roadway designation = IH-number, US-number, SH-number, FM-number

Texas Department of Transportation
Traffic Operations Division Standard

BARRICADE AND CONSTRUCTION PORTABLE CHANGEABLE MESSAGE SIGN (PCMS)

BC (6) - 14

FILE: Dc-14.dgn	DR: TxDOT	CR: TxDOT	EM: TxDOT	CR: TxDOT
NOVEMBER 2002	COUNT: 6379	SECT: 54	JOB: 001	HIGHWAY: SH 174, ETC
REVISTIONS	DIST: 02	COUNTY:	SHEET NO.:	38
9-07 8-14	7-13	JOHNSON		

- Barrier Reflectors shall be pre-qualified, and conform to the color and reflectivity requirements of DMS-8600. A list of prequalified Barrier Reflectors can be found at the Material Producer List web address shown on BC(1).
- Color of Barrier Reflectors shall be as specified in the TMUTCD. The cost of the reflectors shall be considered subsidiary to Item 512.

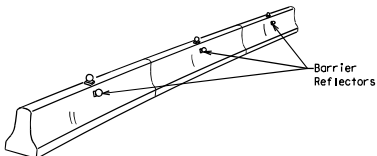

CONCRETE TRAFFIC BARRIER (CTB)

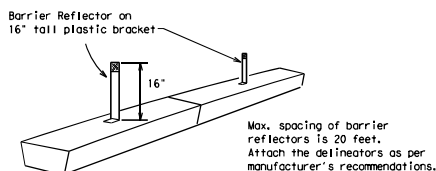

LOW PROFILE CONCRETE BARRIER (LPCB)

- Where traffic is on one side of the CTB, two (2) Barrier Reflectors shall be mounted in approximately the midsection of each section of CTB. An alternate mounting location is uniformly spaced at one end of each CTB. This will allow for attachment of a barrier grapple without damaging the reflector. The Barrier Reflector mounted on the side of the CTB shall be located directly below the reflector mounted on top of the barrier, as shown in the detail above.
- Where CTB separates two-way traffic, three barrier reflectors shall be mounted on each section of CTB. The reflector unit on top shall have two yellow reflective faces (Bi-Directional) while the reflectors on each side of the barrier shall have one yellow reflective face, as shown in the detail above.
- When CTB separates traffic traveling in the same direction, no barrier reflectors will be required on top of the CTB.
- Barrier Reflector units shall be yellow or white in color to match the edgeline being supplemented.
- Maximum spacing of Barrier Reflectors is forty (40) feet.
- Pavement markers or temporary flexible-reflective roadway marker tabs shall NOT be used as CTB delineation.
- Attachment of Barrier Reflectors to CTB shall be per manufacturer's recommendations.
- Missing or damaged Barrier Reflectors shall be replaced as directed by the Engineer.
- Single slope barriers shall be delineated as shown on the above detail.

See D & OM (VIA)

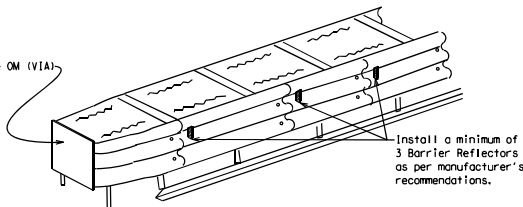

DELINEATION OF END TREATMENTS

END TREATMENTS FOR CTB'S USED IN WORK ZONES

End treatments used on CTB's in work zones shall meet crashworthy standards as defined in the National Cooperative Highway Research Report 350. Refer to the CWZTCD List for approved end treatments and manufacturers.

Arrow Boards may be located behind channelizing devices in place for a shoulder taper or merging taper, otherwise they shall be delineated with four (4) channelizing devices placed perpendicular to traffic on the upstream side of traffic.

- The Flashing Arrow Board should be used for all lane closures on multi-lane roadways, or slow moving maintenance or construction activities on the travel lanes.
- Flashing Arrow Boards should not be used on two-lane, two-way roadways, detours, diversions or work on shoulders unless the "CAUTION" display (see detail below) is used.
- The Engineer/Inspector shall choose all appropriate signs, barricades and/or other traffic control devices that should be used in conjunction with the Flashing Arrow Board.
- The Flashing Arrow Board should be able to display the following symbols:

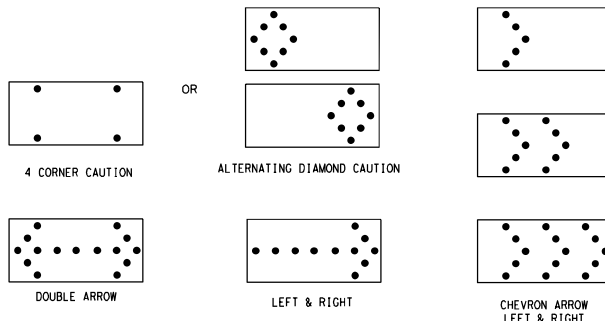

- The "CAUTION" display consists of four corner lamps flashing simultaneously, or the Alternating Diamond Caution mode as shown.
- The straight line caution display is NOT ALLOWED.
- The Flashing Arrow Board shall be capable of minimum 50 percent dimming from rated lamp voltage. The flashing rate of the lamps shall not be less than 25 nor more than 40 flashes per minute.
- Minimum lamp "on time" shall be approximately 50 percent for the flashing arrow and equal intervals of 25 percent for each sequential phase of the flashing chevron.
- The sequential arrow display is NOT ALLOWED.
- The flashing arrow display is the TxDOT standard; however, the sequential Chevron display may be used during daylight operations.
- The Flashing Arrow Board shall be mounted on a vehicle, trailer or other suitable support.
- A Flashing Arrow Board SHALL NOT BE USED to laterally shift traffic.
- A full matrix PCMS may be used to simulate a Flashing Arrow Board provided it meets visibility, flash rate and dimming requirements on this sheet for the same size arrow.
- Minimum mounting height of trailer mounted Arrow Boards should be 7 feet from roadway to bottom of panel.

REQUIREMENTS			
TYPE	MINIMUM SIZE	MINIMUM NUMBER OF PANEL LAMPS	MINIMUM VISIBILITY DISTANCE
B	30 x 60	13	3/4 mile
C	48 x 96	15	1 mile

ATTENTION
Flashing Arrow Boards shall be equipped with automatic dimming devices.

WHEN NOT IN USE, REMOVE THE ARROW BOARD FROM THE RIGHT-OF-WAY OR PLACE THE ARROW BOARD BEHIND CONCRETE TRAFFIC BARRIER OR GUARDRAIL.

FLASHING ARROW BOARDS

SHEET 7 OF 12

DISCLAIMER: The use of this standard is governed by the "Texas Engineering Practice Act". No warranty of any kind is made by TxDOT for any purpose whatsoever. TxDOT assumes no responsibility for the conversion of this standard to other formats or for inaccurate results or damages resulting from its use.

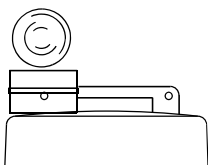

Type C Warning Light or approved substitute mounted on a drum adjacent to the travel way.

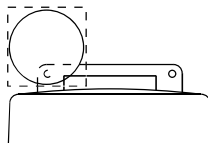

Warning reflector may be round or square. Must have a yellow reflective surface area of at least 30 square inches

WARNING LIGHTS

- Warning lights shall meet the requirements of the TMUTCD.
- Warning lights shall NOT be installed on barricades.
- Type A-Low Intensity Flashing Warning Lights are commonly used with drums. They are intended to warn of or mark a potentially hazardous area. Their use shall be as indicated on this sheet and/or other sheets of the plans by the designation "FL". The Type A Warning Lights shall not be used with signs manufactured with Type B₁ or C₁ Sheeting meeting the requirements of Departmental Material Specification DMS-8300.
- Type-C and Type D 360 degree Steady Burn Lights are intended to be used in a series for delineation to supplement other traffic control devices. Their use shall be as indicated on this sheet and/or other sheets of the plans by the designation "SB".
- The Engineer/Inspector or the plans shall specify the location and type of warning lights to be installed on the traffic control devices.
- When required by the Engineer, the Contractor shall furnish a copy of the warning lights certification. The warning light manufacturer will certify the warning lights meet the requirements of the latest ITE Purchase Specifications for Flashing and Steady-Burn Warning Lights.
- When used to delineate curves, Type-C and Type D Steady Burn Lights should only be placed on the outside of the curve, not the inside.
- The location of warning lights and warning reflectors on drums shall be as shown elsewhere in the plans.

WARNING LIGHTS MOUNTED ON PLASTIC DRUMS

- Type A flashing warning lights are intended to warn drivers that they are approaching or are in a potentially hazardous area.
- Type A random flashing warning lights are not intended for delineation and shall not be used in a series.
- A series of sequential flashing warning lights placed on channelizing devices to form a merging taper may be used for delineation. If used, the successive flashing of the sequential warning lights should occur from the beginning of the taper to the end of the merging taper in order to identify the desired vehicle path. The rate of flashing for each light shall be 65 flashes per minute, plus or minus 10 flashes.
- Type C and D steady-burn warning lights are intended to be used in a series to delineate the edge of the travel lane on detours, on lane changes, on lane closures, and on other similar conditions.
- Type A, Type C and Type D warning lights shall be installed at locations as detailed on other sheets in the plans.
- Warning lights shall not be installed on a drum that has a sign, chevron or vertical panel.
- The maximum spacing for warning lights on drums should be identical to the channelizing device spacing.

WARNING REFLECTORS MOUNTED ON PLASTIC DRUMS AS A SUBSTITUTE FOR TYPE C (STEADY BURN) WARNING LIGHTS

- A warning reflector or approved substitute may be mounted on a plastic drum as a substitute for a Type C, steady burn warning light at the discretion of the Contractor unless otherwise noted in the plans.
- The warning reflector shall be yellow in color and shall be manufactured using a sign substrate approved for use with plastic drums listed on the CWZTCD.
- The warning reflector shall have a minimum retroreflective surface area (one-side) of 30 square inches.
- Round reflectors shall be fully reflectorized, including the area where attached to the drum.
- Square substrates must have a minimum of 30 square inches of reflectorized sheeting. They do not have to be reflectorized where it attaches to the drum.
- The side of the warning reflector facing approaching traffic shall have sheeting meeting the color and retroreflectivity requirements for DMS 8300-Type B or Type C.
- When used near two-way traffic, both sides of the warning reflector shall be reflectorized.
- The warning reflector should be mounted on the side of the handle nearest approaching traffic.
- The maximum spacing for warning reflectors should be identical to the channelizing device spacing requirements.

TRUCK-MOUNTED ATTENUATORS

- Truck-mounted attenuators (TMA) used on TxDOT facilities must meet the requirements outlined in the National Cooperative Highway Research Report No. 350 (NCHRP 350) or the Manual for Assessing Safety Hardware (MASH).
- Refer to the CWZTCD for the requirements of Level 2 or Level 3 TMAs.
- Refer to the CWZTCD for a list of approved TMAs.
- TMAs are required on freeways unless otherwise noted in the plans.
- A TMA should be used anytime that it can be positioned 30 to 100 feet in advance of the area of crew exposure without adversely affecting the work performance.
- The only reason a TMA should not be required is when a work area is spread down the roadway and the work crew is an extended distance from the TMA.



Texas Department of Transportation
Traffic Operations Division Standard

BARRICADE AND CONSTRUCTION ARROW PANEL, REFLECTORS, WARNING LIGHTS & ATTENUATOR

BC (7) - 14

FILE#	bc-14.dgn	DWG	TxDOT	CHK	TxDOT	DWG	TxDOT	CHK	TxDOT
REV#	01	CONV	SECT	JOB	SH	174, ETC			
DATE	9-07	REV#	8-14	DIST	COUNTY	SHEET NO.			
	7-13			02	JOHNSON	39			

DATE: FILE:

GENERAL NOTES

- For long term stationary work zones on freeways, drums shall be used as the primary channelizing device.
- For intermediate term stationary work zones on freeways, drums should be used as the primary channelizing device but may be replaced in tangent sections by vertical panels, or 42" two-piece cones. In tangent sections one-piece cones may be used with the approval of the Engineer but only if personnel are present on the project at all times to maintain the cones in proper position and location.
- For short term stationary work zones on freeways, drums are the preferred channelizing device but may be replaced in tapers, transitions and tangent sections by vertical panels, two-piece cones or one-piece cones as approved by the Engineer.
- Drums and all related items shall comply with the requirements of the current version of the "Texas Manual on Uniform Traffic Control Devices" (TMUTCD) and the "Compliant Work Zone Traffic Control Devices List" (CWZTCD).
- Drums, bases, and related materials shall exhibit good workmanship and shall be free from objectionable marks or defects that would adversely affect their appearance or serviceability.
- The Contractor shall have a maximum of 24 hours to replace any plastic drums identified for replacement by the Engineer/Inspector. The replacement device must be an approved device.

GENERAL DESIGN REQUIREMENTS

Pre-qualified plastic drums shall meet the following requirements:

- Plastic drums shall be a two-piece design; the "body" of the drum shall be the top portion and the "base" shall be the bottom.
- The body and base shall lock together in such a manner that the body separates from the base when impacted by a vehicle traveling at a speed of 20 MPH or greater but prevents accidental separation due to normal handling and/or air turbulence created by passing vehicles.
- Plastic drums shall be constructed of lightweight flexible, and deformable materials. The Contractor shall NOT use metal drums or single piece plastic drums as channelization devices or sign supports.
- Drums shall present a profile that is a minimum of 18 inches in width at the 36 inch height when viewed from any direction. The height of drum unit (body installed on base) shall be a minimum of 36 inches and a maximum of 42 inches.
- The top of the drum shall have a built-in handle for easy pickup and shall be designed to drain water and not collect debris. The handle shall have a minimum of two widely spaced 9/16 inch diameter holes to allow attachment of a warning light, warning reflector unit or approved compliant sign.
- The exterior of the drum body shall have a minimum of four alternating orange and white retroreflective circumferential stripes not less than 4 inches nor greater than 8 inches in width. Any non-reflectorized space between any two adjacent stripes shall not exceed 2 inches in width.
- Bases shall have a maximum width of 36 inches, a maximum height of 4 inches, and a minimum of two footholds of sufficient size to allow base to be held down while separating the drum body from the base.
- Plastic drums shall be constructed of ultra-violet stabilized, orange, high-density polyethylene (HDPE) or other approved material.
- Drum body shall have a maximum unballasted weight of 11 lbs.
- Drum and base shall be marked with manufacturer's name and model number.

RETROREFLECTIVE SHEETING

- The stripes used on drums shall be constructed of sheeting meeting the color and retroreflectivity requirements of Departmental Materials Specification DMS-8300, "Sign Face Materials." Type A reflective sheeting shall be supplied unless otherwise specified in the plans.
- The sheeting shall be suitable for use on and shall adhere to the drum surface such that, upon vehicular impact, the sheeting shall remain adhered in-place and exhibit no delaminating, cracking, or loss of retroreflectivity other than that loss due to abrasion of the sheeting surface.

BALLAST

- Unballasted bases shall be large enough to hold up to 50 lbs. of sand. This base, when filled with the ballast material, should weigh between 35 lbs (minimum) and 50 lbs (maximum). The ballast may be sand in one to three sandbags separate from the base, sand in a sand-filled plastic base, or other ballasting devices as approved by the Engineer. Stacking of sandbags will be allowed, however height of sandbags above pavement surface may not exceed 12 inches.
- Bases with built-in ballast shall weigh between 40 lbs. and 50 lbs. Built-in ballast can be constructed of an integral crumb rubber base or a solid rubber base.
- Recycled truck tire sidewalls may be used for ballast on drums approved for this type of ballast on the CWZTCD list.
- The ballast shall not be heavy objects, water, or any material that would become hazardous to motorists, pedestrians, or workers when the drum is struck by a vehicle.
- When used in regions susceptible to freezing, drums shall have drainage holes in the bottoms so that water will not collect and freeze becoming a hazard when struck by a vehicle.
- Ballast shall not be placed on top of drums.
- Adhesives may be used to secure base of drums to pavement.

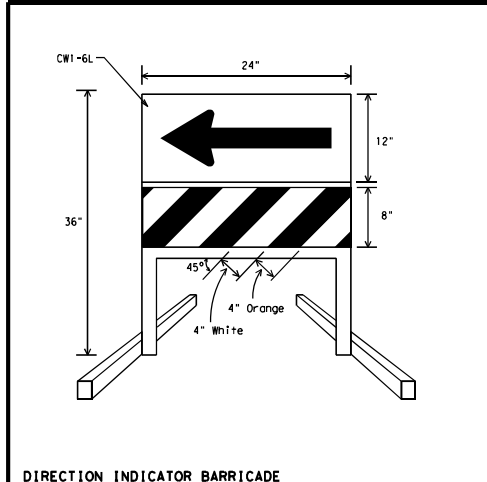
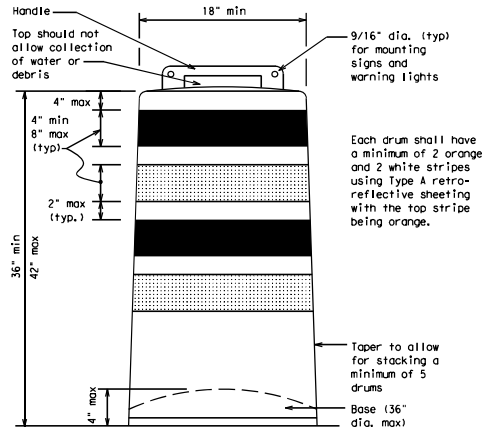

DIRECTION INDICATOR BARRICADES

- The Direction Indicator Barricade may be used in tapers, transitions, and other areas where specific directional guidance to drivers is necessary.
- If used, the Direction Indicator Barricade should be used in series to direct the driver through the transition and into the intended travel lane.
- The Direction Indicator Barricade shall consist of One-Direction Large Arrow (CW1-6L) in the size shown with a black arrow on a background of Type B_{FL} or Type C_{FL} Orange retroreflective sheeting above a roll with Type A retroreflective sheeting in alternating 4" white and orange stripes sloping downward at an angle of 45 degrees in the direction road users are to pass. Sheeting types shall be as per DMS 8300.
- Double arrows on the Direction Indicator Barricade will not be allowed.
- Approved manufacturers are shown on the CWZTCD List. Ballast shall be as approved by the manufacturers instructions.

DETECTABLE PEDESTRIAN BARRICADES

- When existing pedestrian facilities are disrupted, closed, or relocated in a TTC zone, the temporary facilities shall be detectable and include accessibility features consistent with the features present in the existing pedestrian facility.
- Where pedestrians with visual disabilities normally use the closed sidewalk, a device that is detectable by a person with a visual disability traveling with the aid of a long cane shall be placed across the full width of the closed sidewalk.
- Detectable pedestrian barricades similar to the one pictured above, longitudinal channelizing devices, some concrete barriers, and wood or chain link fencing with a continuous detectable edging can satisfactorily delineate a pedestrian path.
- Tape, rope, or plastic chain strung between devices are not detectable, do not comply with the design standards in the "Americans with Disabilities Act Accessibility Guidelines for Buildings and Facilities (ADAAG)" and should not be used as a control for pedestrian movements.
- Warning lights shall not be attached to detectable pedestrian barricades.
- Detectable pedestrian barricades may use 8" nominal barricade rails as shown on BC(10) provided that the top rail provides a smooth continuous rail suitable for hand trailing with no splinters, burrs, or sharp edges.

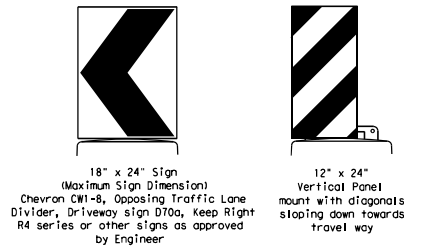

Plywood, Aluminum or Metal sign substrates shall NOT be used on plastic drums

SIGNS, CHEVRONS, AND VERTICAL PANELS MOUNTED ON PLASTIC DRUMS

- Signs used on plastic drums shall be manufactured using substrates listed on the CWZTCD.
- Chevrons and other work zone signs with an orange background shall be manufactured with Type B_{FL} or Type C_{FL} Orange sheeting meeting the color and retroreflectivity requirements of DMS-8300, "Sign Face Material," unless otherwise specified in the plans.
- Vertical Panels shall be manufactured with orange and white sheeting meeting the requirements of DMS-8300 Type A Diagonal stripes on Vertical Panels shall slope down toward the intended traveled lane.
- Other sign messages (text or symbolic) may be used as approved by the Engineer. Sign dimensions shall not exceed 18 inches in width or 24 inches in height, except for the R9 series signs discussed in note 8 below.
- Signs shall be installed using a 1/2 inch bolt (nominal) and nut, two washers, and one locking washer for each connection.
- Mounting bolts and nuts shall be fully engaged and adequately torqued. Bolts should not extend more than 1/2 inch beyond nuts.
- Chevrons may be placed on drums on the outside of curves, on merging tapers or on shifting tapers. When used in these locations they may be placed on every drum or spaced not more than on every third drum. A minimum of three (3) should be used at each location called for in the plans.
- R9-9, R9-10, R9-11 and R9-11a Sidewalk Closed signs which are 24 inches wide may be mounted on plastic drums, with approval of the Engineer.



BARRICADE AND CONSTRUCTION CHANNELIZING DEVICES

BC (8) - 14

FILES:	bc-14.dgn	DW:	TxDOT	CK:	TxDOT	DW:	TxDOT	CK:	TxDOT
REVISED:	November 2002	CHG:	SECT:	JOB:	HIGHWAY:				
4-03	7-13	6379	54	001	SH 174, ETC.				
9-07	8-14	02		JOHNSON	SHEET NO.:	40			

DISCLAIMER: This standard is governed by the "Texas Engineering Practice Act". No warranty of any kind is made by TxDOT for any purpose whatsoever. TxDOT assumes no responsibility for the consequences of this standard to other formats or for incorrect results or damages resulting from its use.

DATE: FILE:

DISCLAIMER: The use of this standard is governed by the "Texas Engineering Practice Act". No warranty of any kind, in whole or in part, is made by the TxDOT for any results or damages resulting from its use.

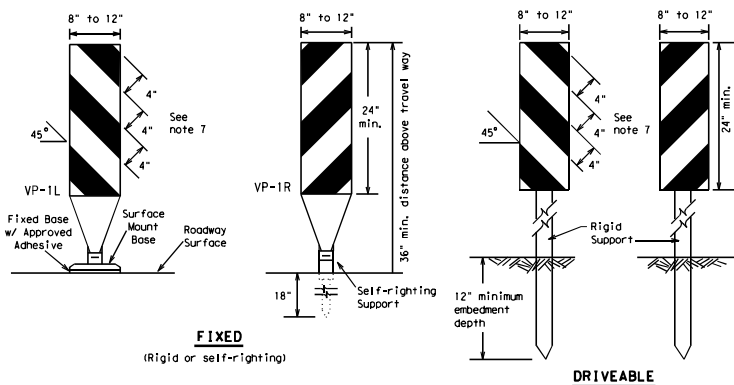

FIXED
(Rigid or self-righting)

DRIVABLE

- Vertical Panels (VP's) are normally used to channelize traffic or divide opposing lanes of traffic.
- VP's may be used in daytime or nighttime situations. They may be used at the edge of shoulder drop-offs and other areas such as lane transitions where positive daytime and nighttime delineation is required. The Engineer/Inspector shall refer to the Roadway Design Manual Appendix B "Treatment of Pavement Drop-offs in Work Zones" for additional guidelines on the use of VP's for drop-offs.
- VP's should be mounted back to back if used at the edge of cuts adjacent to two-way two lane roadways. Stripes are to be reflective orange and reflective white and should always slope downward toward the travel lane.
- VP's used on expressways and freeways or other high speed roadways, may have more than 270 square inches of retroreflective area facing traffic.
- Self-righting supports are available with portable base. See "Compliant Work Zone Traffic Control Devices List" (CWZTCD).
- Sheeting for the VP's shall be retroreflective Type A conforming to Departmental Material Specification DMS-8300, unless noted otherwise.
- Where the height of reflective material on the vertical panel is 36 inches or greater, a panel stripe of 6 inches shall be used.

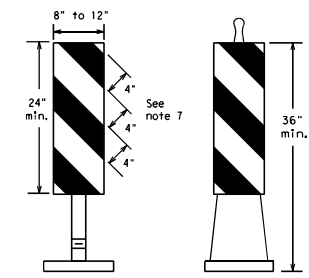

PORTABLE

VERTICAL PANELS (VPs)

- Opposing Traffic Lane Dividers (OTLD) are delineation devices designed to convert a normal one-way roadway section to two-way operation. OTLD's are used on temporary centerlines. The upward and downward arrows on the sign's face indicate the direction of traffic on either side of the divider. The base is secured to the pavement with an adhesive or rubber weight to minimize movement caused by a vehicle impact or wind gust.
- The OTLD may be used in combination with 42" cones or VPs.
- Spacing between the OTLD shall not exceed 500 feet. 42" cones or VPs placed between the OTLD's should not exceed 100 foot spacing.
- The OTLD shall be orange with a black non-reflective legend. Sheeting for the OTLD shall be retroreflective Type B₁ or Type C₁ conforming to Departmental Material Specification DMS-8300, unless noted otherwise. The legend shall meet the requirements of DMS-8300.

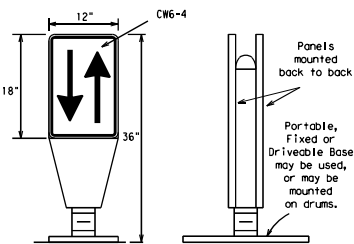

OPPOSING TRAFFIC LANE DIVIDERS (OTLD)

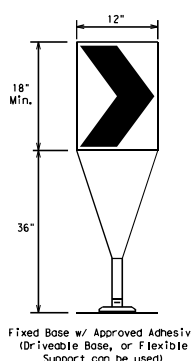

Fixed Base w/ Approved Adhesive (Driveable Base, or Flexible Support can be used)

- The chevron shall be a vertical rectangle with a minimum size of 12 by 18 inches.
- Chevrons are intended to give notice of a sharp change of alignment with the direction of travel and provide additional emphasis and guidance for vehicle operators with regard to changes in horizontal alignment of the roadway.
- Chevrons, when used, shall be erected on the outside of a sharp curve or turn, or on the far side of an intersection. They shall be in line with and at right angles to approaching traffic. Spacing should be such that the motorist always has three in view, until the change in alignment eliminates its need.
- To be effective, the chevron should be visible for at least 500 feet.
- Chevrons shall be orange with a black nonreflective legend. Sheeting for the chevron shall be retroreflective Type B₁ or Type C₁ conforming to Departmental Material Specification DMS-8300, unless noted otherwise. The legend shall meet the requirements of DMS-8300.
- For Long Term Stationary use on tapers or transitions on freeways and divided highways self-righting chevrons may be used to supplement plastic drums but not to replace plastic drums.

CHEVRONS

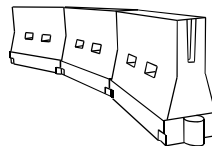

LONGITUDINAL CHANNELIZING DEVICES (LCD)

- LCDs are crashworthy, lightweight, deformable devices that are highly visible, have good target value and can be connected together. They are not designed to contain or redirect a vehicle on impact.
- LCDs may be used instead of a line of cones or drums.
- LCDs shall be placed in accordance to application and installation requirements specific to the device, and used only when shown on the CWZTCD list.
- LCDs should not be used to provide positive protection for obstacles, pedestrians or workers.
- LCDs shall be supplemented with retroreflective delineation as required for temporary barriers on BC(7) when placed roughly parallel to the travel lanes.
- LCDs used as barricades placed perpendicular to traffic should have at least one row of reflective sheeting meeting the requirements for barricade rolls as shown on BC(10) placed near the top of the LCD along the full length of the device.

WATER BALLASTED SYSTEMS USED AS BARRIERS

- Water ballasted systems used as barriers shall not be used solely to channelize road users, but also to protect the work space per the appropriate NCHRP 350 crashworthiness requirements based on roadway speed and barrier application.
- Water ballasted systems used to channelize vehicular traffic shall be supplemented with retroreflective delineation or channelizing devices to improve daytime/nighttime visibility. They may also be supplemented with pavement markings.
- Water ballasted systems used as barriers shall be placed in accordance to application and installation requirements specific to the device, and used only when shown on the CWZTCD list.
- Water ballasted systems used as barriers should not be used for a merging taper except in low speed (less than 45 MPH) urban areas. When used on a taper in a low speed urban area, the taper shall be delineated and the taper length should be designed to optimize road user operations considering the available geometric conditions.
- When water ballasted systems used as barriers have blunt ends exposed to traffic, they should be attenuated as per manufacturer recommendations or flared to a point outside the clear zone.

If used to channelize pedestrians, longitudinal channelizing devices or water ballasted systems must have a continuous detectable bottom for users of long cones and the top of the unit shall not be less than 32 inches in height.

HOLLOW OR WATER BALLASTED SYSTEMS USED AS LONGITUDINAL CHANNELIZING DEVICES OR BARRIERS

GENERAL NOTES

- Work Zone channelizing devices illustrated on this sheet may be installed in close proximity to traffic and are suitable for use on high or low speed roadways. The Engineer/Inspector shall ensure that spacing and placement is uniform and in accordance with the "Texas Manual on Uniform Traffic Control Devices" (TMUTCD).
- Channelizing devices shown on this sheet may have a driveable, fixed or portable base. The requirement for self-righting channelizing devices must be specified in the General Notes or other plan sheets.
- Channelizing devices on self-righting supports should be used in work zone areas where channelizing devices are frequently impacted by errant vehicles or vehicle related wind gusts making alignment of the channelizing devices difficult to maintain. Locations of these devices shall be detailed elsewhere in the plans. These devices shall conform to the TMUTCD and the "Compliant Work Zone Traffic Control Devices List" (CWZTCD).
- The Contractor shall maintain devices in a clean condition and replace damaged, nonreflective, faded, or broken devices and bases as required by the Engineer/Inspector. The Contractor shall be required to maintain proper device spacing and alignment.
- Portable bases shall be fabricated from virgin and/or recycled rubber. The portable bases shall weigh a minimum of 30 lbs.
- Pavement surfaces shall be prepared in a manner that ensures proper bonding between the adhesives, the fixed mount bases and the pavement surface. Adhesives shall be prepared and applied according to the manufacturer's recommendations.
- The installation and removal of channelizing devices shall not cause detrimental effects to the final pavement surfaces, including pavement surface discoloration or surface integrity. Driveable bases shall not be permitted on final pavement surfaces. The Engineer/Inspector shall approve all application and removal procedures of fixed bases.

Posted Speed *	Formula	Minimum Desirable Taper Lengths **			Spacing of Channelizing Devices	
		10' Offset	11' Offset	12' Offset	On a Taper	On a Tangent
30	L = WS / 60	150'	165'	180'	30'	60'
35		205'	225'	245'	35'	70'
40	L = WS	265'	295'	320'	40'	80'
45		450'	495'	540'	45'	90'
50	L = WS	500'	550'	600'	50'	100'
55		550'	605'	660'	55'	110'
60	L = WS	600'	660'	720'	60'	120'
65		650'	715'	780'	65'	130'
70	L = WS	700'	770'	840'	70'	140'
75		750'	825'	900'	75'	150'
80	L = WS	800'	880'	960'	80'	160'
80		800'	880'	960'	80'	160'

**Taper lengths have been rounded off.
L=Length of Taper (FT.) W=Width of Offset (FT.)
S=Posted Speed (MPH)

SUGGESTED MAXIMUM SPACING OF CHANNELIZING DEVICES AND MINIMUM DESIRABLE TAPER LENGTHS

SHEET 9 OF 12



Texas Department of Transportation
Traffic Operations Division Standard

BARRICADE AND CONSTRUCTION CHANNELIZING DEVICES

BC (9) - 14

FILE:	bc-14.dgn	REV:	TxDOT	CHK:	TxDOT	DATE:	TxDOT	CHK:	TxDOT
REV:	1	DATE:	November 2002	CON:	SECT	JOB:	HIGHWAY	REV:	54
REV:	2	DATE:	8-14	CON:	001	COUNTY:	SH 174, ETC	REV:	01
REV:	3	DATE:	7-13	CON:	02	COUNTY:	JOHNSON	REV:	41

DATE: FILE:

DISCLAIMER: The use of this standard is governed by the "Texas Engineering Practice Act". No warranty of any kind is made by the Department of Transportation for the use of this standard or for incorrect results or damages resulting from its use.

TYPE 3 BARRICADES

1. Refer to the Compliant Work Zone Traffic Control Devices List (CWZTD) for details of the Type 3 Barricades and a list of all materials used in the construction of Type 3 Barricades.
2. Type 3 Barricades shall be used at each end of construction projects closed to all traffic.
3. Barricades extending across a roadway should have stripes that slope downward in the direction toward which traffic must turn in detouring. When both right and left turns are provided, the chevron striping may slope downward in both directions from the center of the barricade. Where no turns are provided at a closed road striping should slope downward in both directions toward the center of roadway.
4. Striping of rails, for the right side of the roadway, should slope downward to the left. For the left side of the roadway, striping should slope downward to the right.
5. Identification markings may be shown only on the back of the barricade rails. The maximum height of letters and/or company logos used for identification shall be 1".
6. Barricades shall not be placed parallel to traffic unless an adequate clear zone is provided.
7. Warning lights shall NOT be installed on barricades.
8. Where barricades require the use of weights to keep from turning over, the use of sandbags with dry, cohesionless sand is recommended. The sandbags will be tied shut to keep the sand from spilling and to maintain a constant weight. Sand bags shall not be stacked in a manner that covers any portion of a barricade rails reflective sheeting. Rock, concrete, iron, steel or other solid objects will NOT be permitted. Sandbags should weigh a minimum of 35 lbs and a maximum of 50 lbs. Sandbags shall be made of a durable material that tears upon vehicular impact. Rubber (such as tire inner tubes) shall not be used for sandbags. Sandbags shall only be placed along or upon the base supports of the device and shall not be suspended above ground level or hung with rope, wire, chains or other fasteners.
9. Sheeting for barricades shall be retroreflective Type A conforming to Departmental Material Specification DMS-8300 unless otherwise noted.

Barricades shall NOT be used as a sign support.

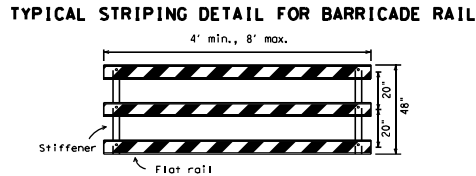
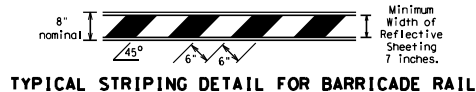

TYPICAL PANEL DETAIL FOR SKID OR POST TYPE BARRICADES

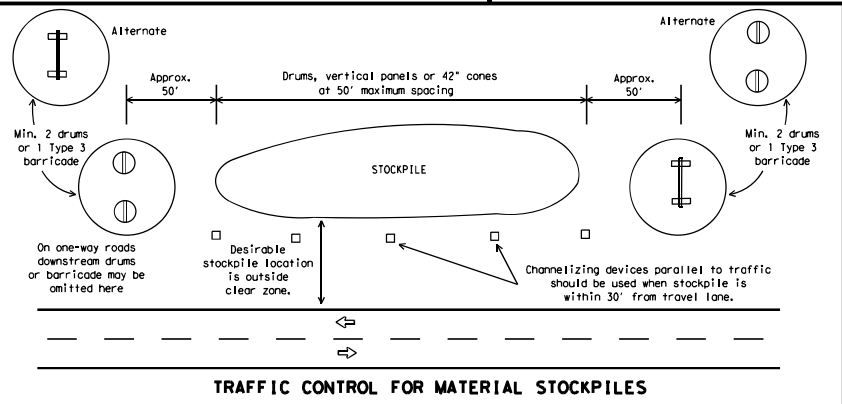

TRAFFIC CONTROL FOR MATERIAL STOCKPILES

Each roadway of a divided highway shall be barricaded in the same manner.

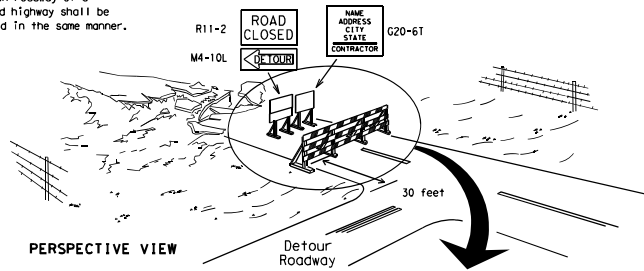

PERSPECTIVE VIEW

The three rolls on Type 3 barricades shall be reflectorized orange and reflective white stripes on one side facing one-way traffic and both sides for two-way traffic. Barricade striping should slant downward in the direction of detour.

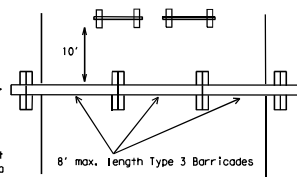

PLAN VIEW

1. Signs should be mounted on independent supports at a 7 foot mounting height in center of roadway. The signs should be a minimum of 10 feet behind Type 3 Barricades.
2. Advance signing shall be as specified elsewhere in the plans.

TYPE 3 BARRICADE (POST AND SKID) TYPICAL APPLICATION

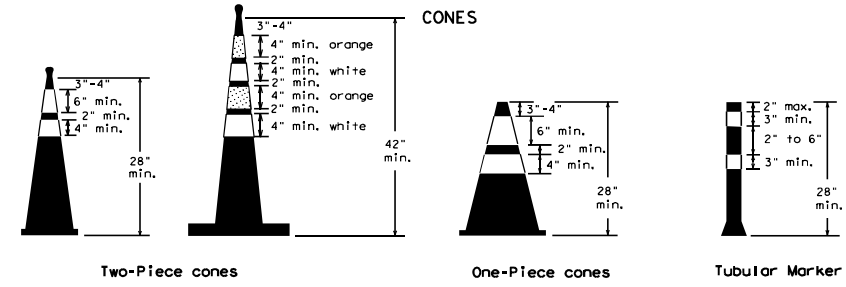

28" Cones shall have a minimum weight of 9 1/2 lbs.
42" 2-piece cones shall have a minimum weight of 30 lbs. including base.

1. Traffic cones and tubular markers shall be predominantly orange, and meet the height and weight requirements shown above.
2. One-piece cones have the body and base of the cone molded in one consolidated unit. Two-piece cones have a cone shaped body and a separate rubber base, or ballast, that is added to keep the device upright and in place.
3. Two-piece cones may have a handle or loop extending up to 8" above the minimum height shown, in order to aid in retrieving the device.
4. Cones or tubular markers used at night shall have white or white and orange reflective bands as shown above. The reflective bands shall have a smooth, sealed outer surface and meet the requirements of Departmental Material Specification DMS-8300 Type 4.
5. 28" cones and tubular markers are generally suitable for short duration and short-term stationary work as defined on BC(14). These should not be used for intermediate-term or long-term stationary work unless personnel is on-site to maintain them in their proper upright position.
6. 42" two-piece cones, vertical panels or drums are suitable for all work zone durations.
7. Cones or tubular markers used on each project should be of the same size and shape.

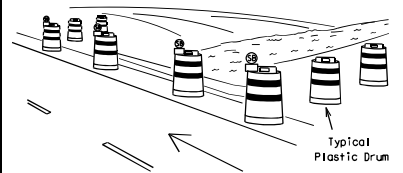

PERSPECTIVE VIEW

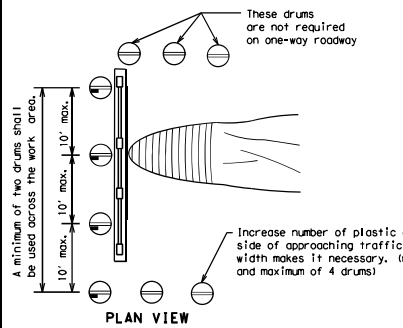

PLAN VIEW

1. Where positive redirection capability is provided, drums may be omitted.
2. Plastic construction fencing may be used with drums for safety as required in the plans.
3. Vertical Panels on flexible support may be substituted for drums when the shoulder width is less than 4 feet.
4. When the shoulder width is greater than 12 feet, steady-burn lights may be omitted if drums are used.
5. Drums must extend the length of the culvert widening.

LEGEND	
	Plastic drum
	Plastic drum with steady burn light or yellow warning reflector
	Steady burn warning light or yellow warning reflector

CULVERT WIDENING OR OTHER ISOLATED WORK WITHIN THE PROJECT LIMITS

THIS DEVICE SHALL NOT BE USED ON PROJECTS LET AFTER MARCH 2014.

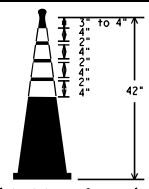

EDGELINE CHANNELIZER

1. This device is intended only for use in place of a vertical panel to channelize traffic by indicating the edge of the travel lane. It is not intended to be used in transitions or tapers.
2. This device shall not be used to separate lanes of traffic (topposing or otherwise) or warn of objects.
3. This device is based on a 42 inch, two-piece cone with an alternate striping pattern: four 4 inch retroreflective bands, with an approximate 2 inch gap between bands. The color of the band should correspond to the color of the edgeline (yellow for left edgeline, white for right edgeline) for which the device is substituted or for which it supplements. The reflectorized bands shall be retroreflective Type A conforming to Departmental Material Specification DMS-8300, unless otherwise noted.
4. The base must weigh a minimum of 30 lbs.

Texas Department of Transportation		Traffic Operations Division Standard	
BARRICADE AND CONSTRUCTION CHANNELIZING DEVICES			
BC (10) - 14			
FILES: DC-14.dgn	DWG: TX001	CHK: TX001	DES: TX001
REV: TX001	NOVEMBER 2002	DATE: 02	BY: SH 174, ETC
9-07	8-14	01	JOHNSON
7-13		02	42

DISCLAIMER: The use of this standard is governed by the "Texas Engineering Practice Act." No warranty of any kind is made by the Texas Department of Transportation for the performance or results or damages resulting from its use. DATE: FILE:

WORK ZONE PAVEMENT MARKINGS

GENERAL

- The Contractor shall be responsible for maintaining work zone and existing pavement markings, in accordance with the standard specifications and special provisions, on all roadways open to traffic within the CSJ limits unless otherwise stated in the plans.
- Color, patterns and dimensions shall be in conformance with the "Texas Manual on Uniform Traffic Control Devices" (TMUTCD).
- Additional supplemental pavement marking details may be found in the plans or specifications.
- Pavement markings shall be installed in accordance with the TMUTCD and as shown on the plans.
- When short term markings are required on the plans, short term markings shall conform with the TMUTCD, the plans and details as shown on the Standard Plan Sheet WZ(STPM).
- When standard pavement markings are not in place and the roadway is opened to traffic, DO NOT PASS signs shall be erected to mark the beginning of the sections where passing is prohibited and PASS WITH CARE signs at the beginning of sections where passing is permitted.
- All work zone pavement markings shall be installed in accordance with Item 662, "Work Zone Pavement Markings."

RAISED PAVEMENT MARKERS

- Raised pavement markers are to be placed according to the patterns on BC(12).
- All raised pavement markers used for work zone markings shall meet the requirements of Item 672, "RAISED PAVEMENT MARKERS" and Departmental Material Specification DMS-4200 or DMS-4300.

PREFABRICATED PAVEMENT MARKINGS

- Removable prefabricated pavement markings shall meet the requirements of DMS-8241.
- Non-removable prefabricated pavement markings (foil back) shall meet the requirements of DMS-8240.

MAINTAINING WORK ZONE PAVEMENT MARKINGS

- The Contractor will be responsible for maintaining work zone pavement markings within the work limits.
- Work zone pavement markings shall be inspected in accordance with the frequency and reporting requirements of work zone traffic control device inspections as required by Form 599.
- The markings should provide a visible reference for a minimum distance of 300 feet during normal daylight hours and 160 feet when illuminated by automobile low-beam headlights at night, unless sight distance is restricted by roadway geometrics.
- Markings failing to meet this criteria within the first 30 days after placement shall be replaced at the expense of the Contractor as per Specification Item 662.

REMOVAL OF PAVEMENT MARKINGS

- Pavement markings that are no longer applicable, could create confusion or direct a motorist toward or into the closed portion of the roadway shall be removed or obliterated before the roadway is opened to traffic.
- The above shall not apply to detours in place for less than three days, where flaggers and/or sufficient channelizing devices are used in lieu of markings to outline the detour route.
- Pavement markings shall be removed to the fullest extent possible, so as not to leave a discernable marking. This shall be by any method approved by TxDOT Specification Item 677 for "Eliminating Existing Pavement Markings and Markers".
- The removal of pavement markings may require resurfacing or seal coating portions of the roadway as described in Item 677.
- Subject to the approval of the Engineer, any method that proves to be successful on a particular type pavement may be used.
- Blast cleaning may be used but will not be required unless specifically shown in the plans.
- Over-painting of the markings SHALL NOT BE permitted.
- Removal of raised pavement markers shall be as directed by the Engineer.
- Removal of existing pavement markings and markers will be paid for directly in accordance with Item 677, "ELIMINATING EXISTING PAVEMENT MARKINGS AND MARKERS," unless otherwise stated in the plans.
- Black-out marking tape may be used to cover conflicting existing markings for periods less than two weeks when approved by the Engineer.

Temporary Flexible-Reflective Roadway Marker Tabs

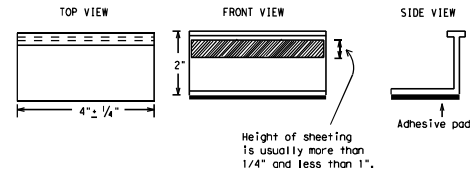

STAPLES OR NAILS SHALL NOT BE USED TO SECURE TEMPORARY FLEXIBLE-REFLECTIVE ROADWAY MARKER TABS TO THE PAVEMENT SURFACE

- Temporary flexible-reflective roadway marker tabs used as guidemarks shall meet the requirements of DMS-8242.
- Tabs detailed on this sheet are to be inspected and accepted by the Engineer or designated representative. Sampling and testing is not normally required, however at the option of the Engineer, either "A" or "B" below may be imposed to assure quality before placement on the roadway.
 - Select five (5) or more tabs at random from each lot or shipment and submit to the Construction Division, Materials and Pavement Section to determine specification compliance.
 - Select five (5) tabs and perform the following test. Affix five (5) tabs at 24 inch intervals on an asphaltic pavement in a straight line. Using a medium size passenger vehicle or pickup, run over the markers with the front and rear tires at a speed of 35 to 40 miles per hour, four (4) times in each direction. No more than one (1) out of the five (5) reflective surfaces shall be lost or displaced as a result of this test.
- Small design variances may be noted between tab manufacturers.
- See Standard Sheet WZ(STPM) for tab placement on new pavements. See Standard Sheet TCP(7-1) for tab placement on seal coat work.

RAISED PAVEMENT MARKERS USED AS GUIDEMARKS

- Raised pavement markers used as guidemarks shall be from the approved product list, and meet the requirements of DMS-4200.
- All temporary construction raised pavement markers provided on a project shall be of the same manufacturer.
- Adhesive for guidemarks shall be bituminous material hot applied or butyl rubber pad for all surfaces, or thermoplastic for concrete surfaces.

Guidemarks shall be designated as:
 YELLOW - (two amber reflective surfaces with yellow body).
 WHITE - (one silver reflective surface with white body).

DEPARTMENTAL MATERIAL SPECIFICATIONS

PAVEMENT MARKERS (REFLECTORIZED)	DMS-4200
TRAFFIC BUTTONS	DMS-4300
EPOXY AND ADHESIVES	DMS-6100
BITUMINOUS ADHESIVE FOR PAVEMENT MARKERS	DMS-6130
PERMANENT PREFABRICATED PAVEMENT MARKINGS	DMS-8240
TEMPORARY REMOVABLE, PREFABRICATED PAVEMENT MARKINGS	DMS-8241
TEMPORARY FLEXIBLE, REFLECTIVE ROADWAY MARKER TABS	DMS-8242

A list of prequalified reflective raised pavement markers, non-reflective traffic buttons, roadway marker tabs and other pavement markings can be found at the Material Producer List web address shown on BC(1).

SHEET 11 OF 12



Texas Department of Transportation
 Traffic Operations Division
 Standard

BARRICADE AND CONSTRUCTION PAVEMENT MARKINGS

BC(11) - 14

FILE:	bc-14.dgn	DN:	TxDOT	CR:	TxDOT	DR:	TxDOT	EN:	TxDOT
© TxDOT	February 1998	CON:	SECT	JOB:	HS08044				
2-98	9-07	6379	54	001	SH 174, ETC				
1-02	7-13	DIST:	COUNTY:	SHEET NO.:					
11-02	8-14	02	JOHNSON	43					

DISCLAIMER: The use of this standard is governed by the "Texas Engineering Practice Act". No warranty of any kind is made by TxDOT for any purpose whatsoever. TxDOT assumes no responsibility for the conversion of this standard to other formats or for incorrect results or damages resulting from its use.

PAVEMENT MARKING PATTERNS

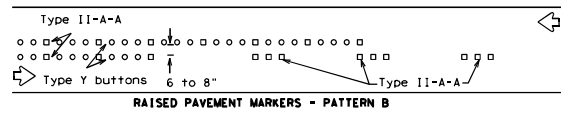
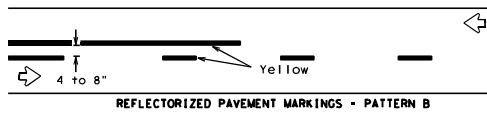
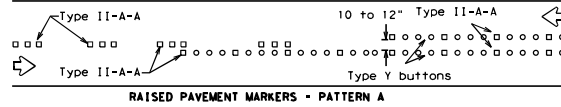
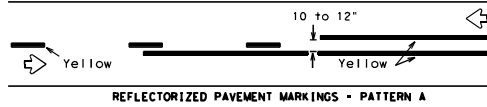

Pattern A is the TxDOT Standard, however Pattern B may be used if approved by the Engineer. Prefabricated markings may be substituted for reflectORIZED pavement markings.

CENTER LINE & NO-PASSING ZONE BARRIER LINES FOR TWO-LANE, TWO-WAY HIGHWAYS

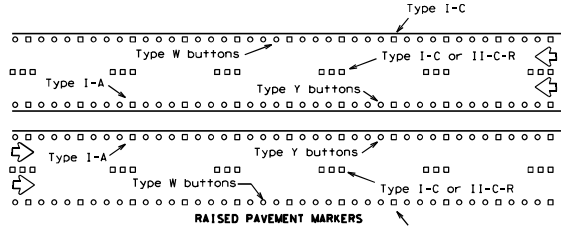
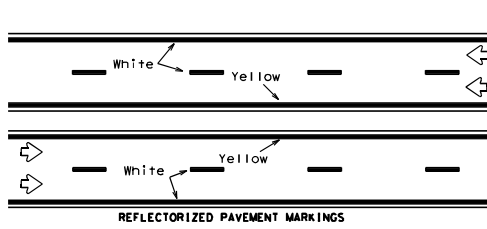

Prefabricated markings may be substituted for reflectORIZED pavement markings.

EDGE & LANE LINES FOR DIVIDED HIGHWAY

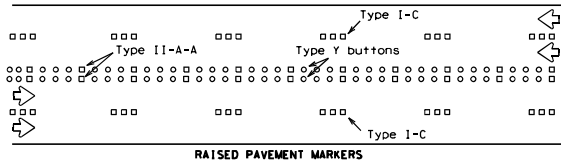
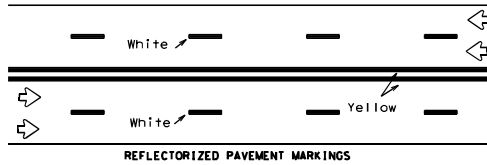

Prefabricated markings may be substituted for reflectORIZED pavement markings.

LANE & CENTER LINES FOR MULTILANE UNDIVIDED HIGHWAYS

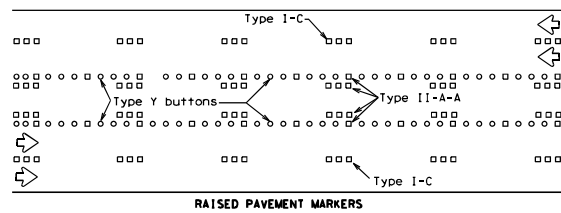
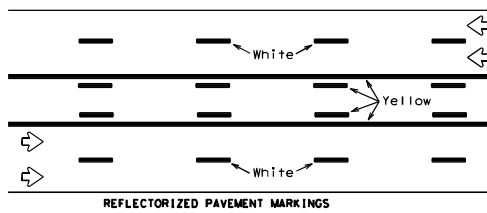

Prefabricated markings may be substituted for reflectORIZED pavement markings.

TWO-WAY LEFT TURN LANE

STANDARD WORK ZONE PAVEMENT MARKINGS DETAILS

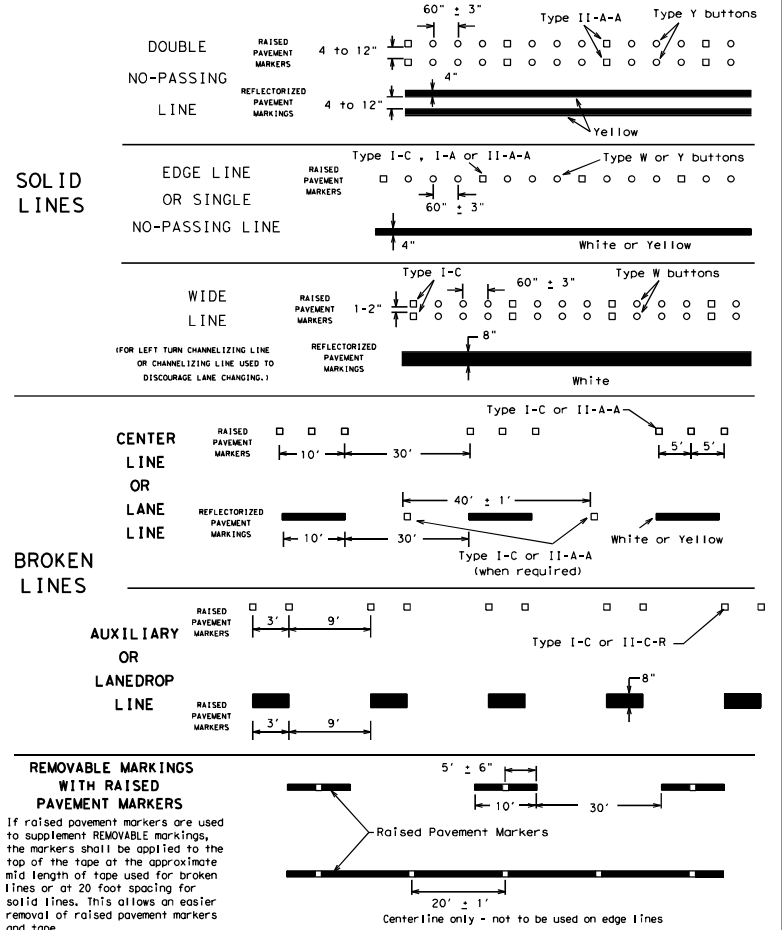

Raised pavement markers used as standard pavement markings shall be from the approved products list and meet the requirements of Item 672 "RAISED PAVEMENT MARKERS."

SHEET 12 OF 12



BARRICADE AND CONSTRUCTION PAVEMENT MARKING PATTERNS

BC(12)-14

FILE: bc-14.dgn	DN: TxDOT	CHK: TxDOT	DR: TxDOT	CR: TxDOT
© TxDOT February 1998	CONT: 6379	SECT: 54	JOB: 001	HIGHWAY: SH 174, ETC
1-97 9-07 REVISIONS	DIST: 02	COUNTY: JOHNSON	SHEET NO.:	44
2-98 7-13				
11-02 8-14				

DATE:
FILE:

DISCLAIMER: This standard is governed by the "Texas Engineering Practice Act". No warranty of any kind is made by TxDOT for any purpose whatsoever. TxDOT assumes no responsibility for the conversion of this standard to other formats or for incorrect results or damages resulting from its use.

DATE: FILE:

Warning sign and rumble strip sequence in opposite direction is same as below

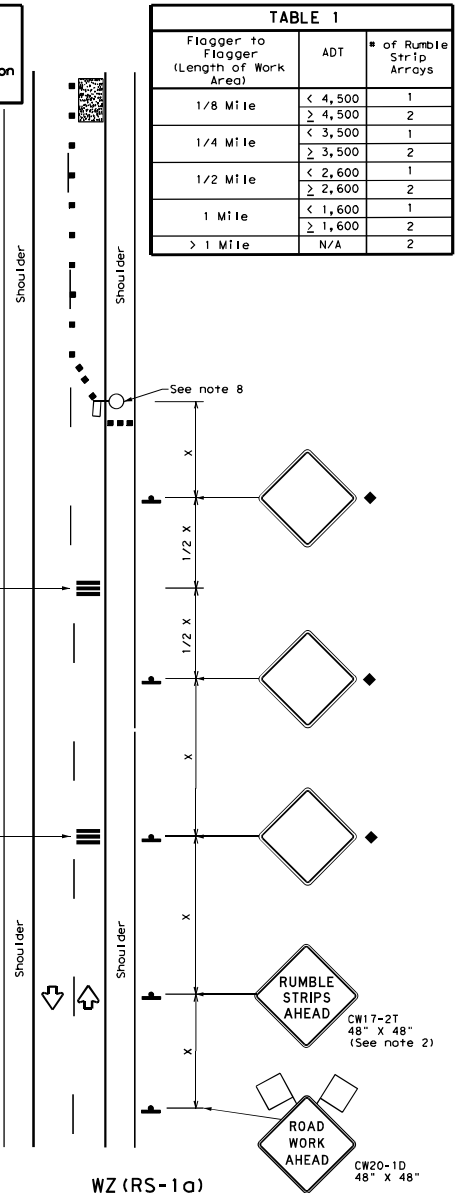

WZ (RS-1a)
75 mph or Less
RUMBLE STRIPS ON ONE-LANE TWO-WAY APPLICATION

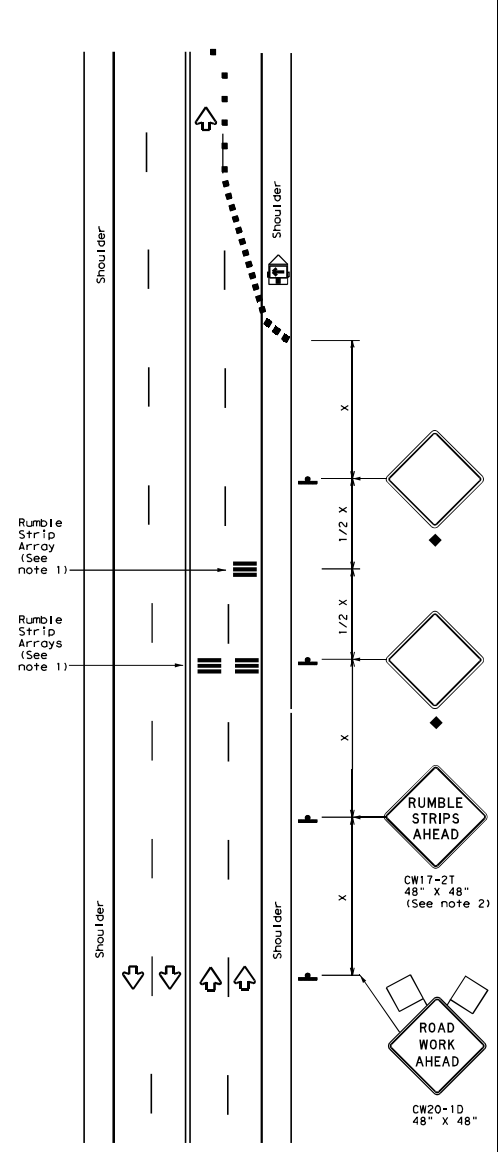

WZ (RS-1b)
75 mph or Less
RUMBLE STRIPS FOR LANE CLOSURE ON CONVENTIONAL ROADWAY

GENERAL NOTES

- Each Rumble Strip Array should consist of three rumble strips spaced center to center at the spacing shown in Table 2, placed transverse across the lane at locations shown.
- The CW17-2T "RUMBLE STRIPS AHEAD" sign should be located after the CW20-1D "ROAD WORK AHEAD" sign and spaced as shown. If traffic is observed to be queuing, or is expected to queue beyond the Rumble Strips, the CW17-2T sign and the first Rumble Strip Array may be located upstream of the CW20-1D sign as necessary to provide needed warning.
- Temporary Rumble Strips will be considered subsidiary to Item 502, and shall be a product listed on the Compliant Work Zone Traffic Control Devices.
- Removal of the Temporary Rumble Strips should be accomplished before removing the advance warning signs.
- Temporary Rumble Strips should not be used on horizontal curves, loose gravel, soft or bleeding asphalt, heavily rutted pavements or unpaved surfaces.
- Temporary Rumble Strips shall be installed and maintained as per manufacturer's recommendations.
- This standard sheet shall be used in conjunction with other appropriate TCP standard, TMUTCD typical application or project specific detail for the project.
- The one-lane two-way application may utilize a flagger, an AFAD or a portable traffic signal.
- Temporary Rumble Strips may be based on engineering judgment.

Speed	Approximate distance between strips in an Array
≤ 40 MPH	10'
> 40 MPH & ≤ 55 MPH	15'
> 55 MPH	20'

	Type 3 Barricade		Channelizing Devices
	Heavy Work Vehicle		Truck Mounted Attenuator (TMA)
	Trailer Mounted Flashing Arrow Panel		Portable Changeable Message Sign (PCMS)
	Flag		Traffic Flag
			Flagger

Posted Speed X	Formula	Minimum Desirable Taper Lengths * X			Suggested Maximum Spacing of Channelizing Devices		Minimum Sign Spacing * X	Suggested Longitudinal Buffer Space * B
		10' Offset	11' Offset	12' Offset	On a Taper	On a Tangent		
30	L = WS ² / 60	150'	165'	180'	30'	60'	120'	90'
35		205'	225'	245'	35'	70'	160'	120'
40	L = WS	265'	295'	320'	40'	80'	240'	155'
45		450'	495'	540'	45'	90'	320'	195'
50	L = WS	500'	550'	600'	50'	100'	400'	240'
55		550'	605'	660'	55'	110'	500'	295'
60	L = WS	600'	660'	720'	60'	120'	600'	350'
65		650'	715'	780'	65'	130'	700'	410'
70	L = WS	700'	770'	840'	70'	140'	800'	475'
75		750'	825'	900'	75'	150'	900'	540'

* Conventional Roads Only
 ** Taper lengths have been rounded off.
 L=Length of Taper (FT) W=Width of Offset (FT)
 S=Posted Speed (MPH)

MOBILE	SHORT DURATION	SHORT TERM STATIONARY	INTERMEDIATE TERM STATIONARY	LONG TERM STATIONARY
	✓	✓		

◆ Signs are for illustrative purposes only. Signs required may vary depending on the TCP, TMUTCD Typical Application, or project specific details for the project.

Traffic Operations Division Standard

TEMPORARY RUMBLE STRIPS

WZ (RS) - 16

FILES: wzs16.dgn	DATE: TxDOT	CHK: TxDOT	DATE: TxDOT	CHK: TxDOT
© TxDOT November 2012	CONT: SECT	JOB: HIGHWAY		
REVISIONS	6379	54	001	SH 174, ETC
2-14	DIST	COUNTY	SHEET NO.	
4-16	02	JOHNSON	45	