

TxDOT  
52800.0000 FT. / in.

3/23/2021  
I:\MACMAIN\1\RMC-Contracts\BaseFiles\pvm\m\in\fy-2022\FALLS\CADD\SHEETS\TITLE-ONTY.dgn

INDEX OF SHEETS	
SHEET No.	DESCRIPTION
1	TITLE SHEET
2	INDEX OF SHEETS

# STATE OF TEXAS

## DEPARTMENT OF TRANSPORTATION

### PLANS OF PROPOSED HIGHWAY ROUTINE MAINTENANCE CONTRACT

#### TYPE OF WORK:

**BASE FAILURE PAVEMENT REPAIR**

PROJECT No. : RMC 637946001  
 HIGHWAY No. : SH 320, ETC  
 LIMITS OF WORK: FALLS COUNTY

MAINTENANCE PROJECT No.				SHEET No.
RMC 637946001				1
DRAFT	STATE	DISTRICT	COUNTY	
DL	TEXAS	WACO	FALLS	
CHECK	CONT	SECT	JOB	HIGHWAY No.
MD	6379	46	001	SH 320, ETC

AREA OF DISTURBED SOIL = 0.000 ACRES

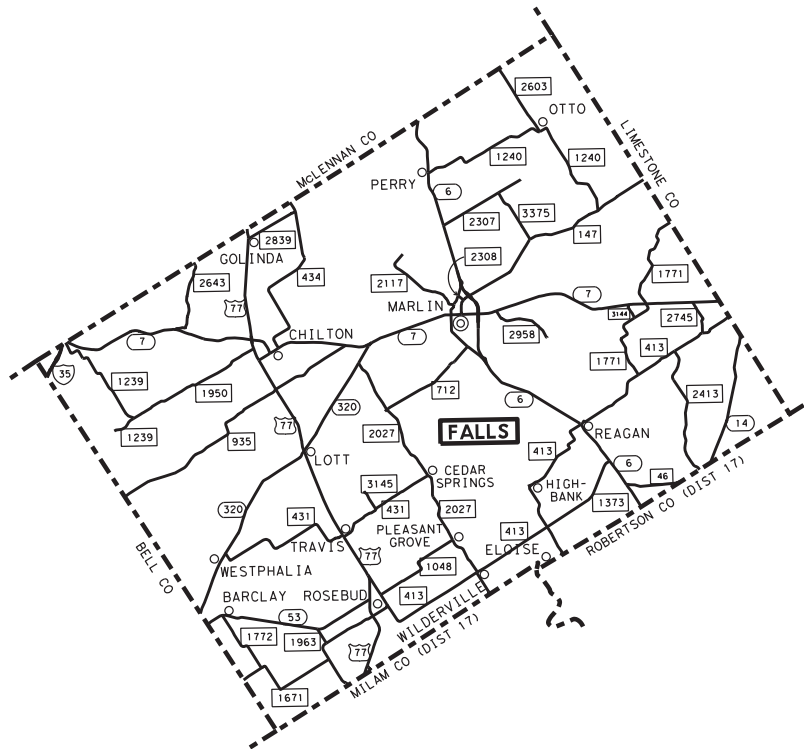

**TEXAS DEPARTMENT OF TRANSPORTATION**  
 RECOMMENDED FOR LETTING:

\_\_\_\_\_  
 AREA ENGINEER  
 RECOMMENDED FOR LETTING: \_\_\_\_\_ 20

*Stanley Swiatek*  
 DIRECTOR OF OPERATIONS  
 SUBMITTED FOR LETTING: \_\_\_\_\_ March 29, 20 21

DocuSigned by:  
**Stanley Swiatek** \_\_\_\_\_ 3/29/2021  
 B69BD796DD564C9...

SPECIFICATIONS ADOPTED BY THE TEXAS DEPARTMENT OF TRANSPORTATION, NOVEMBER 1, 2014 AND PROVISIONAL ITEMS INCLUDED HEREIN, SHALL GOVERN ON THIS CONTRACT.

© 2021 Texas Department of Transportation  
 All Rights Reserved

EXCEPTIONS: NONE  
 EQUATIONS: NONE  
 RAILROAD: NONE

TxDOT  
200.0000 ft / in.

SHEET	DESCRIPTION
<b><u>I. GENERAL</u></b>	
1	TITLE SHEET
2	INDEX OF SHEETS
3	PROJECT LAYOUT
4	TYPICAL SECTIONS
5 - 50	GENERAL NOTES & SPECIFICATION DATA
6	ESTIMATE & QUANTITY SHEET
7 - 8	SUMMARY SHEETS
<b><u>II. TRAFFIC CONTROL PLAN</u></b>	
<b>STANDARDS</b>	
9 - 20	# BC (1) THRU (12) - 14
21 - 26	# TCP (1-1) THRU (1-6) - 18
27 - 32	# TCP (2-1) THRU (2-6) - 18
33 - 36	# TCP (3-1) (3-2) (3-4) - 13 AND (3-3) - 14
37	# TCP (5-1) - 18
38 - 44	# TCP (6-1) THRU (6-5), - 12 AND (6-8), (6-9) - 14
45	# TCP (7-1) - 13
46	# WZ (TD) - 17
47	# WZ (STPM) - 13
48	# WZ (UL) - 13
49	# WZ (RS) - 16

SHEET	DESCRIPTION
<b><u>III. ROADWAY DETAILS</u></b>	
-	NONE
<b><u>IV. RETAINING WALL DETAILS</u></b>	
<b><u>V. DRAINAGE DETAILS</u></b>	
-	NONE
<b><u>VI. UTILITIES</u></b>	
-	NONE
<b><u>VII. BRIDGES</u></b>	
-	NONE

SHEET	DESCRIPTION
<b><u>VIII. TRAFFIC DETAILS</u></b>	
50 - 53	# PM (1) THRU (4) - 20
54 - 58	# FPM (1) THRU (4) - 12 AND (5) - 19
<b><u>IX. ENVIRONMENTAL DETAILS</u></b>	
<b>STANDARDS</b>	
59	# EC (1) - 16
<b>WACO DISTRICT STANDARDS</b>	
60 - 69	# TA - BMP
<b><u>X. MISCELLANEOUS ITEMS</u></b>	
-	NONE



STANDARD SHEETS SPECIFICALLY IDENTIFIED WITH (\*)  
HAVE BEEN SELECTED BY ME OR UNDER MY RESPONSIBLE  
SUPERVISION AS BEING APPLICABLE TO THIS PROJECT.

*Mark T. Davis* P.E.      3-23-2021  
DATE

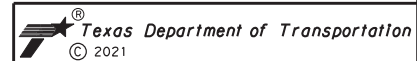

**INDEX OF SHEETS  
FALLS COUNTY**

DESIGN DL	FED RD DIV No.	PROJECT No.		HIGHWAY No.
CHECK MD	6	RMC 637946001		SH 320, ETC
GRAPHICS DL	STATE	DISTRICT	COUNTY	SHEET No.
CHECK MD	TEXAS	WACO	FALLS	<b>2</b>
	CONTROL	SECTION	JOB	
	6379	46	001	

3/23/2021  
T:\MACMINTY\...RMC\_Contracts\Base\G1\ure\_P\mt\m\in\FY-2022\FALLS\CADD\SHEETS\INDEX.dgn

T:\001  
26400.0000 ft / in.

3/23/2021  
T:\MACMAIN\1\RMC\_Contracts\Base\G:\Iure\_P\m\Main\FY-2022\FALLS\CADD\SHEETS\PL-Fal1.s.dgn

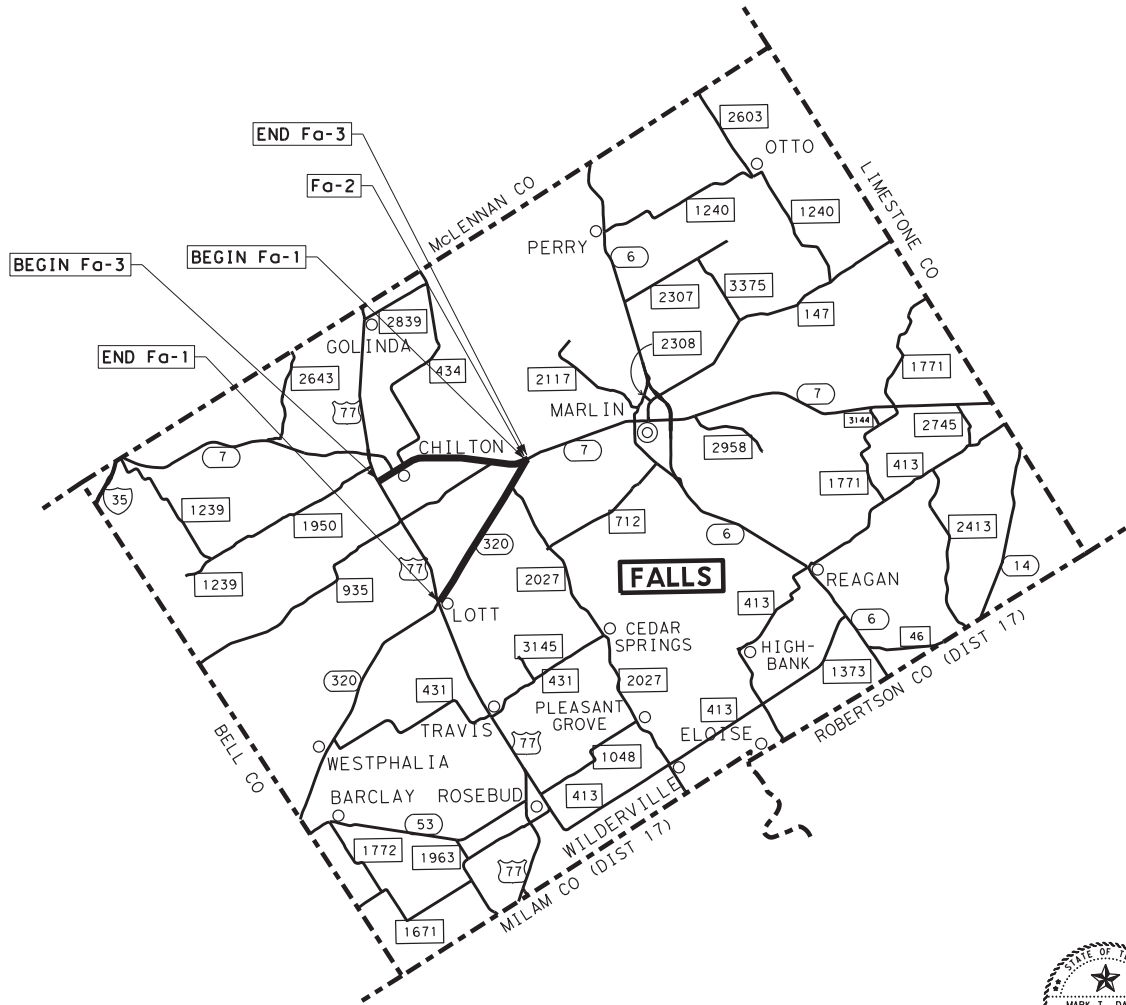

LEGEND

CODE	RDMY	REF_MKR TO	REF_MKR
Fa-1	SH 320	368	374
Fa-2	SH 7		578
Fa-3	SH 7	572	578



The seal appearing on this document was authorized by MARK T. DAVIS, P.E. 135628, on

*Mark T. Davis*, PE 3-23-2021  
Signature of Registrant & Date

Texas Department of Transportation  
© 2021

PROJECT LAYOUT  
FALLS COUNTY

SCALE: 1" = 5 MILES

DESIGN DL	FED RD DIV No.	PROJECT No.	HIGHWAY No.
CHECK MD	6	RMC 637946001	SH 320, ETC
GRAPHICS DL	STATE	DISTRICT	COUNTY
CHECK MD	TEXAS	WACO	FALLS
	CONTROL	SECTION	JOB
	6379	46	001
			SHEET No.
			3

TxDOT  
5.0000 ft / in.

3/23/2021  
T:\MACMAIN\1\1\_RMC\_Contracts\BaseFiles\Falls\PG64\SHSHEETS\TYP01.dgn

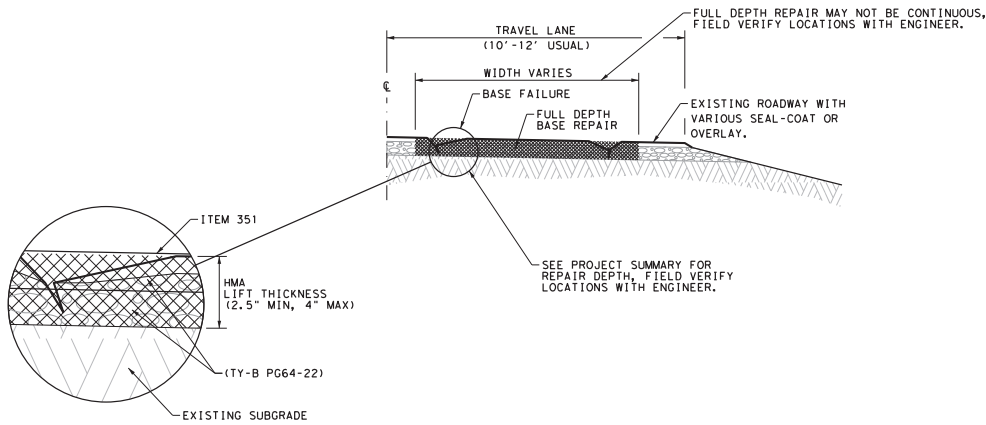

**FLEXIBLE PAVEMENT STRUCTURE REPAIR  
PROPOSED TYPICAL SECTION**

**NOTES:**

1. APPROXIMATE LOCATION AND DEPTH OF PROPOSED PLANING (MILLING), AND OR PAVEMENT REMOVAL IS LOCATED IN THE PROJECT SUMMARY, FIELD VERIFY WITH ENGINEER.
2. INSTALL WK ZN PAV MKR SHT TERM (TAB) AT LOCATIONS WHERE THE SCOPE OF THE WORK ELIMINATES THE EXISTING STRIPING AND/OR AS DIRECTED BY THE ENGINEER.
3. RIDE QUALITY OF THE COMPLETED REPAIR WILL BE TO THE SATISFACTION OF THE ENGINEER.
4. THE REMOVAL OF THE EXISTING PAVEMENT STRUCTURE WILL BE DONE WITH A MILLING MACHINE, RECLAIMER, SAWCUT/EXCAVATOR, OR OTHER EQUIPMENT APPROVED BY THE ENGINEER.



The seal appearing on this document was authorized by MARK T. DAVIS P.E. 135628, on

*Mark T. Davis*, PE 3-23-2021  
Signature of Registrant & Date



**TYPICAL SECTIONS  
FALLS COUNTY**

SCALE: 1" = NTS

DESIGN DL	FED RD DIV No.	PROJECT No.		HIGHWAY No.
CHECK MD	6	RMC 637946001		SH 320, ETC
GRAPHICS DL	STATE	DISTRICT	COUNTY	SHEET No.
CHECK MD	TEXAS	WACO	FALLS	
	CONTROL	SECTION	JOB	4
	6379	46	001	

**PROJECT NUMBER: RMC 637946001****COUNTY: FALLS****HIGHWAY: SH 320, ETC****CONTROL: 6379-46-001****GENERAL**

Contract for base failure repair, on various roadways in Falls County, according to the standard specifications or as modified in the general specifications listed below.

The construction, operation and maintenance of the proposed project will be consistent with the state implementation plan as prepared by the Texas Commission on Environmental Quality.

The disturbed area for this project, as shown on the plans is 0 acres. However, the Total Disturbed Area (TDA) will establish the required authorization for storm water discharges. The TDA of this project will be determined by the sum of the disturbed area in all project locations in the contract, and all disturbed area on all Project-Specific Locations (PSL) located in the project limits and/or within 1 mile of the project limits. The department will obtain an authorization to discharge storm water from the Texas Commission on Environmental Quality (TCEQ) for the construction site as shown on the plans, according to the TDA of the project. The contractor will obtain any required authorization from the TCEQ for the discharge of storm water from any PSL for construction support activities on or off of the project row according to the TDA of the project. When the TDA for the project exceeds 1 acre, provide a copy of the appropriate application of permit (NOI, or Construction Site Notice) to the engineer, for any PSL located in the project limits or within 1 mile of the project limits. Follow the directives and adhere to all requirements set forth in the TCEQ, Texas Pollution Discharge Elimination System, Construction General Permit (TPDES, CGP).

Contractor questions on this project are to be emailed to the Waco District at the following address:

Bill Compton - [Wacoprebid@txdot.gov](mailto:Wacoprebid@txdot.gov), 254-867-2707, 100 S. Loop Dr., Waco, TX  
Carmen Chau - [Wacoprebid@txdot.gov](mailto:Wacoprebid@txdot.gov), 254-867-2794, 100 S. Loop Dr., Waco, TX

All contractor questions will be reviewed by the Engineer. Once a response is developed, it will be posted to TxDOT's Public FTP at the following Address:  
<https://ftp.dot.state.tx.us/pub/txdot-info/Pre-Letting/Responses/>

All questions submitted that generate a response will be posted through this site. The site is organized by District, Project Type (Construction or Maintenance), Letting Date, CCS./Project Name.

GENERAL NOTES

**PROJECT NUMBER: RMC 637946001****SHEET NO.....5****COUNTY: FALLS****HIGHWAY: SH 320, ETC****CONTROL: 6379-46-001**

Office of Record: For this contract, the office of record will be the Texas Department of Transportation office listed below.

Maint. Supervisor	Telephone Number	Maint. Office Location
Chad Blansit	(254) 883-3462	5092 Highway 7
Falls County		Marlin, TX 76661

Quantities as shown in the plans are estimated quantities only. The actual quantities will vary.

Roadway locations and work areas will be as determined by the Engineer. Work locations and quantities will be field verified.

**GENERAL NOTES****ITEM 2: INSTRUCTIONS TO BIDDERS**

This proposed Contract will not include federal funds. Bid tabulations will include stipulations in accordance with 2.11.5.3 "Rubber Additives" and 2.11.5.5 "Home State Bidding Preference".

**ITEM 4: SCOPE OF WORK**

Flexible pavement structure repairs will be limited to areas where all work at the locations can be completed the same work day. The Engineers reserves the right to make changes in the work, including addition, reduction, or elimination of quantities and alterations to complete this contract.

**ITEM 5: CONTROL OF THE WORK**

Underground utilities owned by the Texas Department of Transportation may be present within the Right-Of-Way on this project. For signal, illumination, surveillance, and communications & control maintained by TxDOT, call the TxDOT Traffic Signal Office (254)867-2808 for locates a minimum of 48 hours in advance of excavation. For irrigation systems, call TxDOT Landscape Office (254)867-2726 for locates a minimum of 48 hours in advance of excavation. If city or town owned irrigation facilities are present, call the appropriate department of the local city or town a minimum of 48 hours in advance of excavation. The Contractor is liable for all damages when utilities are damaged due to Contractor's negligence including, but not limited to, repair or replacement at the Contractor's expense.

GENERAL NOTES

PROJECT NUMBER: RMC 637946001

COUNTY: FALLS

HIGHWAY: SH 320, ETC

CONTROL: 6379-46-001

**ITEM 6: CONTROL OF MATERIALS**

This proposed Contract will not include federal funds. Buy Texas stipulations apply in accordance with 6.1.2 "Buy Texas".

References to manufacturer's trade name or catalog numbers are for the purpose of identification only and the contractor will be permitted to furnish like materials of other manufacturers provided they are of equal quality and comply with specifications for this project.

**ITEM 7: LEGAL RELATIONS AND RESPONSIBILITIES**

If utilizing private property for field office sites, equipment storage sites or for any other purpose involved with this project, provide to the Engineer written proof of the property owner's approval of the use of this property. This proof may be in the form of a letter or agreement signed by the property owner or other documents acceptable to the Engineer.

Where existing pavement adjoins new pavement, saw the existing pavement to a neat transverse and/or longitudinal line to permit adequate joining. This will not be paid for directly, but will be considered subsidiary to the various bid items.

Protect all adjoining pavement sections during all phases of construction. Any damages incurred due to Contractor's operation will be repaired and/or replaced at the Contractor's expense.

Personal vehicles of the contractor's employees will not be parked within the right of way at anytime including any section closed to public traffic, unless the vehicle is being utilized for construction procedures. However the contractor's employees may park on the right of way at the sites where the contractor has his office, equipment and materials storage yard.

The contractor is alerted to the possible presence of swallows under the existing bridges or culverts. Because the migratory bird treaty act prohibits harm to swallows, their eggs or their nestlings, the contractor will not begin potentially disturbing activities on or near the bridge until the birds have abandoned any occupied nests (approximately September 1). Active nests may not be removed regardless of the date.

Prior to the swallows returning to the nests (approximately March 1), abandoned nests will be removed from the bridge. The contractor will prevent the establishment of new nests on any portion of the structure. Methods for preventing the establishment of new nests must be approved by the project Engineer. Examples of acceptable nest prevention methods are bird-deterrent netting and bird-repelling sprays and/or gels to be applied to the structure. This work will not be paid for directly, but will be subsidiary to the various bid items.

GENERAL NOTES

PROJECT NUMBER: RMC 637946001

SHEET No.....5A

COUNTY: FALLS

HIGHWAY: SH 320, ETC

CONTROL: 6379-46-001

**ITEM 8: PROSECUTION AND PROGRESS**

This Project will be Calendar Day in accordance with Article 8.3.1.5.

The duration for this contract is 365 calendar days. For specific locations listed on the plan, Contractor will have the liberty to determine the start working date. However, work on these specific locations must be completed by July 31, 2022.

Meet bi-weekly or at intervals as agreed upon with the engineer to notify him or her of planned work for the upcoming 3-week period.

Provide the engineer with a daily work schedule of planned activities including anticipated quantities of materials (CY of each concrete placement, tons of HMAC to be placed, etc.).

This contract will consist of multiple work orders. This contract will commence upon issuance of a Work Order. In accordance with Article 8.1, "Prosecution of Work"; begin work within **seven (7) calendar days** after the written authorization to begin work as shown on the work order. Working day charges will begin when the Contractor begins work but no later than 7 calendar days after the written authorization.

Work on areas inside city limits shall be performed at night unless otherwise approved by the Engineer.

Work in more than one location at a time shall be approved by the Engineer.

The Engineer will notify the Contractor in writing to begin the initial work.

The Contractor will furnish such suitable machinery, equipment and construction forces as may be necessary, in the opinion of the Engineer, for proper prosecution of the work.

The Contractor will use a crew experienced in pavement repair and in the necessary traffic control.

At all times, the Contractor's personnel will be dressed in approved safety attire while outside vehicles and/or while performing work on the highway right of way. This will include but is not limited to hard hats and safety vests.

The Contractor will clean up and remove from all work areas all loose material resulting from the contract operations each day before work is suspended. No loose material will remain at the work site overnight.

The Contractor will be responsible for leaving the project site clean and neat in appearance upon completion and before final acceptance by the Engineer.

GENERAL NOTES

**PROJECT NUMBER: RMC 637946001**

**COUNTY: FALLS**

**HIGHWAY: SH 320. ETC**

**CONTROL: 6379-46-001**

**ITEM 351: FLEXIBLE PAVEMENT STRUCTURE REPAIR**

Provide (4) inches of D-GR HMA TY B PG 64-22 for all repairs. D-GR HMA TY B PG 64-22 will not be measured but will be considered subsidiary to Item 351, "Flexible Pavement Structure Repair".

For this project, a laydown machine will be required during the construction & placement of this item.

Locations and Quantities will vary as directed. The minimum area to be repaired will be five (5) SY.

Excess material removed from repairs will become the property of the contractor.

**ITEM 500: MOBILIZATION**

Material On Hand (MOH) will not be used in calculating partial payments for Mobilization.

Mobilization (Callout) will be paid with each work order.

**ITEM 502: BARRICADES, SIGNS, AND TRAFFIC HANDLING**

Traffic control will not be paid for directly, but shall be considered subsidiary to the various bid items.

Prior to beginning work, the Contractor and Engineer will agree on the allowable length of lane closure.

The Contractor will be responsible for furnishing, erecting, and maintaining all signs and traffic control devices necessary to provide for the safe passage of traffic in and around the work zone. All traffic control devices will conform to the plan sheets and the Texas Manual of Uniform Traffic Control Devices (TMUTCD).

Flaggers will be required at locations where work could endanger the traveling public or as directed by the Engineer/Project Manager.

The Contractor Force Account "Safety Contingency" that has been established for this project is intended to be utilized for work zone enhancements, to improve the effectiveness of the Traffic Control Plan, that could not be foreseen in the project planning and design stage. These enhancements will be mutually agreed upon by the Engineer and the Contractor's Responsible Person based on weekly or more frequent traffic management reviews on the project. The Engineer may choose to use existing bid items if it does not slow the implementation of enhancement.

**GENERAL NOTES**

**PROJECT NUMBER: RMC 637946001**

**SHEET No.5B**

**COUNTY: FALLS**

**HIGHWAY: SH 320. ETC**

**CONTROL: 6379-46-001**

Access will be provided to all business and residences at all times. Where turning radii are limited during phased construction at intersections, provide all weather surfaces such as RAP or base in turning movements to accommodate and to protect the traffic from edge drop-offs. Materials, labor, maintenance and removal for these temporary accesses and radii will not be paid for directly but will be considered subsidiary to the various bid items.

Provide written proposed lane closure information by 1:00 pm on the business day prior to the proposed closures. Do not close lanes when this requirement is not met.

When excavation is required next to a pavement lane carrying traffic and the widening is not completed by the end of the work day, backfill against the edge of the pavement with at least a 3:1 slope using an acceptable material to support vehicular traffic. Carefully remove and dispose of this material when work resumes. Backfilling pavement edges, and the materials required for the work will be subsidiary to this item.

Open the pavement to traffic each night. Remove all material stockpiles, equipment left overnight or any obstruction within thirty (30) feet of a travel way or clearly mark by warning lights and barricades.

Equip all construction equipment involved in roadway work with a permanently mounted warning light with amber lens as approved

Place barricades and signs in locations that do not obstruct the sight distance of drivers entering the highway from driveways or side streets.

As approved by the Engineer, provide uniformed off duty police officers and squad cars during lane or ramp closures, night time work or other situations that indicate a need for additional traffic control to protect the traveling public or the construction workforce. Provide documentation such as payroll, log sheets with signatures and badge number, or invoices from the government entity providing the officers for reimbursement. Complete the weekly tracking form provided by the department and submit invoices that agree with the tracking form for payment at the end of each month approved services were provided. Reimbursement will not be made for coordination fees charged by any party.

The Contractor Responsible Person(s) (CRP) for Work Zone Traffic Controls will inspect and ensure any deficiencies are corrected each and every day throughout the duration of this contract. Any misaligned or damaged traffic control devices will be repaired as soon as practical after deficiency is discovered.

In addition to providing a Contractor's Responsible Person and a phone number for emergency contact, have an employee(s) available to respond on the project for emergencies and for taking corrective measures within One (1) Hour.

**GENERAL NOTES**

**PROJECT NUMBER: RMC 637946001**

**COUNTY: FALLS**

**HIGHWAY: SH 320. ETC**

**CONTROL: 6379-46-001**

**ITEM 666: RETROREFLECTORIZED PAVEMENT MARKINGS**

The Contractor will layout the proposed striping in accordance with TxDOT Traffic Control Plan Standards and latest version Texas Manual on Uniform Traffic Control Devices (TMUTCD). The Engineer will verify proposed striping layout prior to the beginning of striping operations.

The Contractor will locate the beginning and ending points of No Pass Zones.

All stop lines will be twenty-four (24) inches wide.

Pavement Surface Preparation for Markings will not be paid for directly, but will be subsidiary to Item 666, "Retroreflectorized Pavement Markings".

Remove markings at own expense that are not in alignment or sequence, as shown on the standard sheets or as stated in the specifications, or do not meet the specification and/or approval of the Project Manager. Removal will be in accordance with Item 677, "Eliminating Existing Pavement Markings and Markers", except for measurement and payment

**ITEM 672: RAISED PAVEMENT MARKERS**

Before the application of pavement markers, sufficiently clean pavement surfaces to remove all forms of contamination and loose materials, in accordance with Item 678, "Pavement Surface Preparation for Markings". This work will not be paid for directly, but will be subsidiary to Item 672, "Raised Pavement Markers".

Remove at Contractor's expense all markers placed that are not in alignment or sequence, as shown on the standard sheets or as stated in the specifications, or do not meet the specification and/or approval of the Project Manager. Removal will be in accordance with Item 677, "Eliminating Existing Pavement Markings and Markers", except for measurement and payment.

**GENERAL NOTES**

**PROJECT NUMBER: RMC 637946001**

**SHEET No.....5C**

**COUNTY: FALLS**

**HIGHWAY: SH 320. ETC**

**CONTROL: 6379-46-001**

**ITEM 6001: PORTABLE CHANGEABLE MESSAGE SIGN**

This project will require "full matrix" type portable changeable message signs.

Ensure that the Contractor's Responsible Person for traffic control can revise messages within thirty (30) minutes of notification.

Furnish 2 portable changeable message signs. The portable changeable message sign(s) will be used for all lane closures and freeway closures as shown on the traffic control plan standard sheets.

Supply portable changeable message sign(s) in accordance with the Traffic Control Plan standard sheets and Article 6f.55 of the Texas Manual on Uniform Traffic Control Devices for Streets and Highways Part VI.

**GENERAL NOTES**



**PROJECT NUMBER: RMC 637946001**

**COUNTY: FALLS**

**HIGHWAY: SH 320. ETC**

**CONTROL: 6379-46-001**

**ITEM 6185: TRUCK MOUNTED ATTENUATORS**

The total number of truck mounted attenuators (TMA) required when utilizing the traffic control standards are shown in the tables below.

TCP 1 Series	Scenario	Required TMA	
(1-1)-18 / (1-2)-18		1	
(1-3)-18	A   B	1	2
(1-4)-18 / (1-5)-18 / (1-6)-18		1	

TCP 2 Series	Scenario	Required TMA	
(2-1)-18 / (2-2)-18 / (2-4)-18 / (2-5)-18 / (2-6)-18	All	1	
(2-3)-18	A   B	1	2

TCP 3 Series	Scenario	Required TMA	
(3-1)-13	All	2	
(3-2)-13	All	3	
(3-3)-14	A   B   D	2	
	C	3	
(3-4)-13	All	1, unless working inside a twtl, then 2.	

TCP 6 Series	Scenario	Required TMA	
(6-1)-12	A   B	1	2
(6-2)-12 / (6-3)-12	All	1	
(6-4)-12	A   B	1	2
(6-5)-12	A   B	1	2
(6-8)-14 / (6-9)-14	All	1	

Shadow vehicles equipped for truck mounted attenuators (TMA) for stationary operations will be paid for by the day and must be available for use at any time as determined by the Engineer.

Mobile operations will be paid for by the hour, per specifications. For mobile operations, payment will be made only while the TMA is in use.

**GENERAL NOTES**

**PROJECT NUMBER: RMC 637946001**

**SHEET No.5D**

**COUNTY: FALLS**

**HIGHWAY: SH 320. ETC**

**CONTROL: 6379-46-001**

For mobile operations requiring multiple TMA's, judgement may be applied in lower speed, urban / in town traffic environments to reduce the numbers of TMA in use where the added TMA may pose a hazard for traffic entering and exiting driveways, side streets, etc.

The contractor will be responsible for determining if one or more of these operations will be ongoing at the same time to determine the total number of TMA needed for the project for those times per plan requirements. Additional TMAs used that are not specified in the plans in which the contractor expects compensation will require prior approval from the Engineer.

**GENERAL NOTES**



TxDOT  
200.0000 ft / in.

**BASE FAILURE / PAVEMENT REPAIR**

COUNTY	ROADWAY	LIMITS (FROM - TO) OR (LANDMARKS)	NEAREST REFERENCE MARKER		LEGEND CODE	LENGTH (FT)	WIDTH (FT)	AREA (SY)	0351	0500	0662	0662	0666	0666	0666	0666	0666
			6013	6001					6109	6111	6048	6300	6303	6312	6315		
			FLEXIBLE PAVEMENT STRUCTURE REPAIR (4")	MOBILIZATION (CALLOUT)					WK ZN PAV MRK SHT TERM (TAB) TY W	WK ZN PAV MRK SHT TERM (TAB) TY Y-2	REFL PAV MRK TY I (W) 24" (SLD) (100 MIL)	RE PM W/RET REQ TY I (W) 4" (BRK) (100 MIL)	RE PM W/RET REQ TY I (W) 4" (SLD) (100 MIL)	RE PM W/RET REQ TY I (Y) 4" (BRK) (100 MIL)	RE PM W/RET REQ TY I (Y) 4" (SLD) (100 MIL)		
			SY	EA					EA	EA	LF	LF	LF	LF	LF		
Falls	SH 320	SH 7 "Y" to LOTT	368	374	Fa-1	280	24	747	747		28	28		70	280	70	280
						2650	12	3534	3534		265	265		663	2650	663	2650
						235	10	262	262		24	24		59	235	59	235
						190	8	169	169		19	19		48	190	48	190
	SH 7	AT SH 320 "Y"	578		Fa-2	1000	12	1334	1334		100	100		250	1000	250	1000
	SH 7	US 77 WB to SH 320 "Y"	572	578	Fa-3	1000	12	1334	1334		100	100		250	1000	250	1000
		TBD															
<b>PROJECT TOTALS</b>									<b>7380</b>	<b>3</b>	<b>536</b>	<b>536</b>	<b>100</b>	<b>1339</b>	<b>5355</b>	<b>1340</b>	<b>5355</b>

TOTALS SHOWN ARE APPROXIMATE, QUANTITIES AND LOCATIONS ARE FOR ESTIMATION PURPOSES ONLY.  
 WORK AREAS AND LOCATIONS MAY BE ADDED AND REMOVED, AND MUST BE VERIFIED BY ENGINEER PRIOR TO ANY WORK ACTIVITIES.  
 CONSTRUCTION OPERATIONS MAY NOT BE CONTINUOUS, FIELD VERIFY WITH ENGINEER.

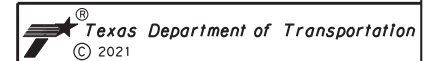

**SUMMARY SHEET  
FALLS COUNTY**

Sheet 1 of 2

DESIGN DL	FED RD DIV No.	PROJECT No.		HIGHWAY No.
CHECK MD	6	RMC 637946001		SH 320, ETC
GRAPHICS DL	STATE	DISTRICT	COUNTY	SHEET No.
CHECK MD	TEXAS	WACO	FALLS	7
	CONTROL	SECTION	JOB	
	6379	46	001	

3/23/2021  
T:\MACMINTY\...RMC\_Contracts\BaseFiles\ure\_Pvm\Maint\FY-2022\FALLS\CADD\SHEETS\SUM01.dgn

**BASE FAILURE / PAVEMENT REPAIR**

COUNTY	ROADWAY	LIMITS (FROM - TO) OR (LANDMARKS)	NEAREST REFERENCE MARKER		LEGEND CODE	LENGTH (FT)	WIDTH (FT)	AREA (SY)	0672	0672	6001	6185	6185
			6007	6009					6001	6002	6003		
			REFL PAY MRKR TY I-C	REFL PAY MRKR TY II-A-A					PORTABLE CHANGEABLE MESSAGE SIGN	TMA (STATIONARY)	TMA (MOBIL OPERATION)		
			FROM	TO				EA	EA	DAY	DAY	HR	
Falls	SH 320	SH 7 "Y" to LOTT	368	374	Fa-1	280	24	747		4			
						2650	12	3534		33			
						235	10	262		3			
						190	8	169		2			
	SH 7	AT SH 320 "Y"	578	Fa-2	1000	12	1334		13				
	SH 7	US 77 WB to SH 320 "Y"	572	578	Fa-3	1000	12	1334		13			
	TBD							200		80	40	100	
<b>PROJECT TOTALS</b>									<b>200</b>	<b>67</b>	<b>80</b>	<b>40</b>	<b>100</b>

TOTALS SHOWN ARE APPROXIMATE, QUANTITIES AND LOCATIONS ARE FOR ESTIMATION PURPOSES ONLY.  
 WORK AREAS AND LOCATIONS MAY BE ADDED AND REMOVED, AND MUST BE VERIFIED BY ENGINEER PRIOR TO ANY WORK ACTIVITIES.  
 CONSTRUCTION OPERATIONS MAY NOT BE CONTINUOUS, FIELD VERIFY WITH ENGINEER.



**SUMMARY SHEET  
FALLS COUNTY**

Sheet 2 of 2

DESIGN DL	FED RD DIV No.	PROJECT No.		HIGHWAY No.
CHECK MD	6	RMC 637946001		SH 320, ETC
GRAPHICS DL	STATE	DISTRICT	COUNTY	SHEET No.
CHECK MD	TEXAS	WACO	FALLS	8
	CONTROL	SECTION	JOB	
	6379	46	001	

DISCLAIMER: This document is prepared by the Texas Engineering Experiment Station, No responsibility is assumed by the State of Texas or the Texas Department of Transportation for any errors or omissions in this document. The user assumes all responsibility for the use of this document for any purpose whatsoever. TxDOT assumes no responsibility for the conversion of this document to other formats or for incorrect results or damages resulting from its use.

DATE: 3/23/2021 9:44:38 AM  
FILE: T:\MACMINTY\TMC\_Contractors\Bosefoglure\_P\mtm\in\FY-2022\FALLS\CADD\SHEETS\STANDARDS\bc-14.dgn

**BARRICADE AND CONSTRUCTION (BC) STANDARD SHEETS GENERAL NOTES:**

- The Barricade and Construction Standard Sheets (BC sheets) are intended to show typical examples for placement of temporary traffic control devices, construction pavement markings, and typical work zone signs. The information contained in these sheets meet or exceed the requirements shown in the "Texas Manual on Uniform Traffic Control Devices" (TMUTCD).
- The development and design of the Traffic Control Plan (TCP) is the responsibility of the Engineer.
- The Contractor may propose changes to the TCP that are signed and sealed by a licensed professional engineer for approval. The Engineer may develop, sign and seal Contractor proposed changes.
- The Contractor is responsible for installing and maintaining the traffic control devices as shown in the plans. The Contractor may not move or change the approximate location of any device without the approval of the Engineer.
- Geometric design of lane shifts and detours should, when possible, meet the applicable design criteria contained in manuals such as the American Association of State Highway and Transportation Officials (AASHTO), "A Policy on Geometric Design of Highways and Streets," the TxDOT "Roadway Design Manual" or engineering judgment.
- When projects abut, the Engineer(s) may omit the END ROAD WORK, TRAFFIC FINES DOUBLE, and other advance warning signs if the signing would be redundant and the work areas appear continuous to the motorists. If the adjacent project is completed first, the Contractor shall erect the necessary warning signs as shown on these sheets, the TCP sheets or as directed by the Engineer. The BEGIN ROAD WORK NEXT X MILES sign shall be revised to show appropriate work zone distance.
- The Engineer may require duplicate warning signs on the median side of divided highways where median width will permit and traffic volumes justify the signing.
- All signs shall be constructed in accordance with the details found in the "Standard Highway Sign Designs for Texas," latest edition. Sign details not shown in this manual shall be shown in the plans or the Engineer shall provide a detail to the Contractor before the sign is manufactured.
- The temporary traffic control devices shown in the illustrations of the BC sheets are examples. As necessary, the Engineer will determine the most appropriate traffic control devices to be used.
- As shown on BC(2), the OBEY WARNING SIGNS STATE LAW sign, STAY ALERT TALK OR TEXT LATER (see Sign Detail G20-10T) and the WORK ZONE TRAFFIC FINES DOUBLE sign with plaque shall be erected in advance of the CSJ limits. However, the TRAFFIC FINES DOUBLE sign will not be required on projects consisting solely of mobile operation work, such as striping or milling edgeline rumble strips. The BEGIN ROAD WORK NEXT X MILES, CONTRACTOR and END ROAD WORK signs shall be erected at or near the CSJ limits.
- Except for devices required by Note 10, traffic control devices should be in place only while work is actually in progress or a definite need exists.
- The Engineer has the final decision on the location of all traffic control devices.
- Inactive equipment and work vehicles, including workers' private vehicles must be parked away from travel lanes. They should be as close to the right-of-way line as possible, or located behind a barrier or guardrail, or as approved by the Engineer.

**WORKER SAFETY APPAREL NOTES:**

- Workers on foot who are exposed to traffic or to construction equipment within the right-of-way shall wear high-visibility safety apparel meeting the requirements of ISEA "American National Standard for High-Visibility Apparel," or equivalent revisions, and labeled as ANSI 107-2004 standard performance for Class 2 or 3 risk exposure. Class 3 garments should be considered for high traffic volume work areas or night time work.

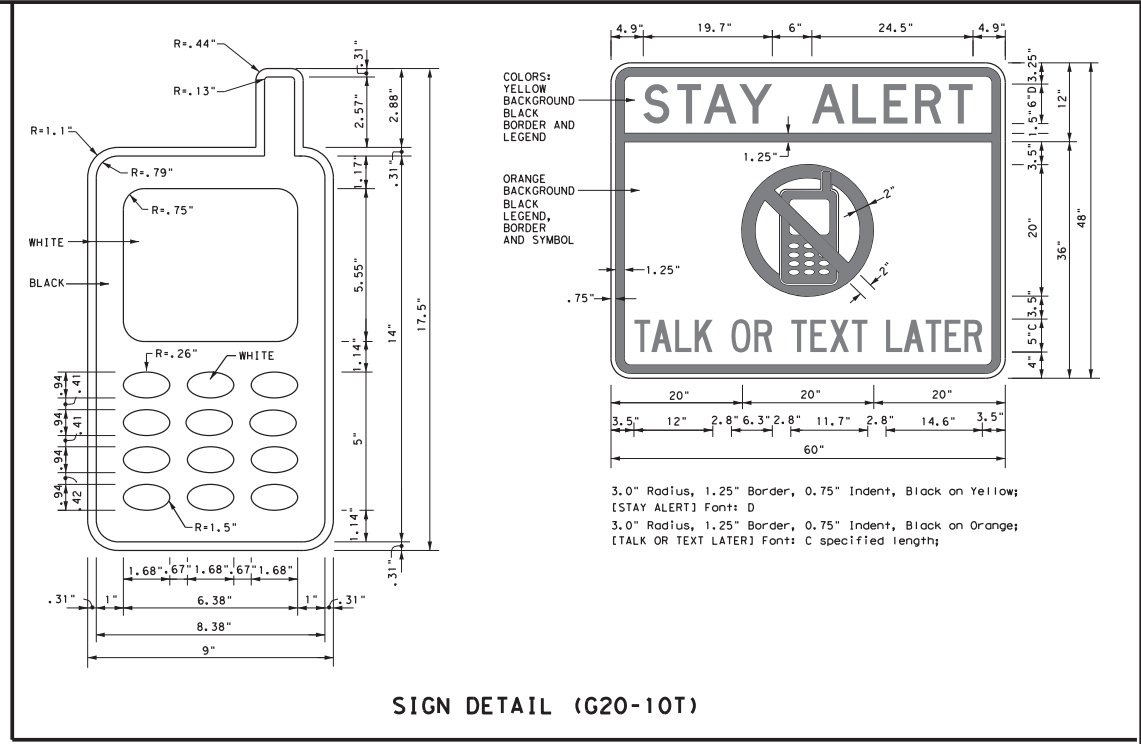

Only pre-qualified products shall be used. The "Compliant Work Zone Traffic Control Devices List" (CWZTCD) describes pre-qualified products and their sources and may be found on-line at the web address given below or by contacting:

Texas Department of Transportation  
 Traffic Operations Division - TE  
 Phone (512) 416-3118

THE DOCUMENTS BELOW CAN BE FOUND ON-LINE AT <http://www.txdot.gov>

COMPLIANT WORK ZONE TRAFFIC CONTROL DEVICES LIST (CWZTCD)
DEPARTMENTAL MATERIAL SPECIFICATIONS (DMS)
MATERIAL PRODUCER LIST (MPL)
ROADWAY DESIGN MANUAL - SEE "MANUALS (ONLINE MANUALS)"
STANDARD HIGHWAY SIGN DESIGNS FOR TEXAS (SHSD)
TEXAS MANUAL ON UNIFORM TRAFFIC CONTROL DEVICES (TMUTCD)
TRAFFIC ENGINEERING STANDARD SHEETS

SHEET 1 OF 12

**Texas Department of Transportation**  
Traffic Operations Division Standard

**BARRICADE AND CONSTRUCTION  
GENERAL NOTES  
AND REQUIREMENTS**

**BC(1) - 14**

FILE: bc-14.dgn	DN: TxDOT	CR: TxDOT	DR: TxDOT	EX: TxDOT
© TxDOT November 2002	CONT SECT	JOB	HIGHWAY	
4-03 REVISIONS	6379 46	001	SH 320, ETC	
5-10 8-14	DIST	COUNTY	SHEET NO.	
9-07 7-13	WACO	FALLS	9	

### TYPICAL LOCATION OF CROSSROAD SIGNS

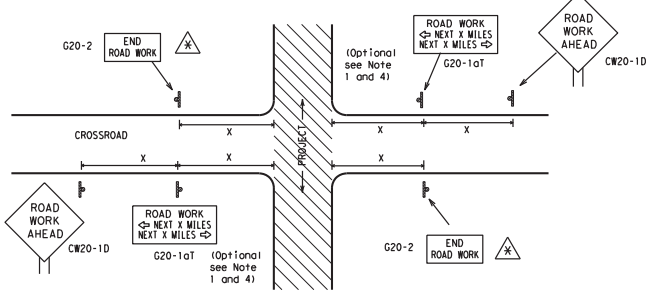

- May be mounted on back of "ROAD WORK AHEAD" (CW20-1D) sign with approval of Engineer. (See note 2 below)
- The typical minimum signing on a crossroad approach should be a "ROAD WORK AHEAD" (CW20-1D) sign and a (G20-2) "END ROAD WORK" sign, unless noted otherwise in plans.
  - The Engineer may use the reduced size 36" x 36" ROAD WORK AHEAD (CW20-1D) sign mounted back to back with the reduced size 36" x 18" "END ROAD WORK" (G20-2) sign on low volume crossroads (see Note 4 under "Typical Construction Warning Sign Size and Spacing"). See the "Standard Highway Sign Designs for Texas" manual for sign details. The Engineer may omit the advance warning signs on low volume crossroads. The Engineer will determine whether a road is low volume. This information shall be shown in the plans.
  - Based on existing field conditions, the Engineer/Inspector may require additional signs such as FLAGGER AHEAD, LOOSE GRAVEL, or other appropriate signs. When additional signs are required, these signs will be considered part of the minimum requirements. The Engineer/Inspector will determine the proper location and spacing of any sign not shown on the BC sheets, Traffic Control Plan sheets or the Work Zone Standard Sheets.
  - The "ROAD WORK NEXT X MILES" (G20-1aT) sign shall be required at high volume crossroads to advise motorists of the length of construction in either direction from the intersection. The Engineer will determine whether a roadway is considered high volume.
  - Additional traffic control devices may be shown elsewhere in the plans for higher volume crossroads.
  - When work occurs in the intersection area, appropriate traffic control devices, as shown elsewhere in the plans or as determined by the Engineer/Inspector, shall be in place.

### T-INTERSECTION

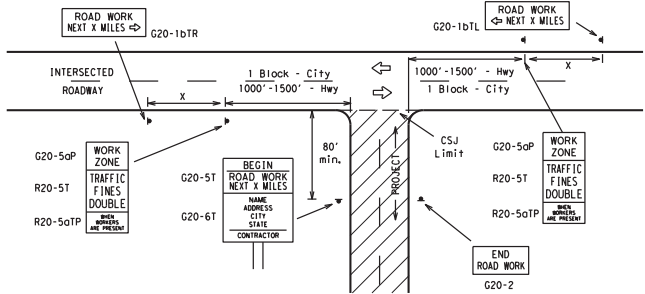

#### CSJ LIMITS AT T-INTERSECTION

- The Engineer will determine the types and location of any additional traffic control devices, such as a flagger and accompanying signs, or other signs, that should be used when work is being performed at or near an intersection.
- If construction closes the road at a T-intersection the Contractor shall place the "CONTRACTOR NAME" (G20-6T) sign behind the Type 3 Barricades for the road closure (see BC(10) also). The "ROAD WORK NEXT X MILES" left arrow (G20-1bTL) and "ROAD WORK NEXT X MILES" right arrow (G20-1bTR) signs shall be replaced by the detour signing called for in the plans.

### TYPICAL CONSTRUCTION WARNING SIGN SIZE AND SPACING

Sign Number or Series	SIZE		SPACING	
	Conventional Road	Expressway/Freeway	Posted Speed MPH	Sign Spacing "X" Feet (Approx.)
CW20 <sup>4</sup>	48" x 48"	48" x 48"	30	120
CW21			35	160
CW22			40	240
CW23			45	320
CW25			50	400
CW1, CW2, CW7, CW8, CW9, CW11, CW14	36" x 36"	48" x 48"	55	500 <sup>2</sup>
			60	600 <sup>2</sup>
			65	700 <sup>2</sup>
			70	800 <sup>2</sup>
			75	900 <sup>2</sup>
CW3, CW4, CW5, CW6, CW8-3, CW10, CW12	48" x 48"	48" x 48"	80	1000 <sup>2</sup>
			*	*
			*	*

\* For typical sign spacings on divided highways, expressways and freeways, see Part 6 of the "Texas Manual on Uniform Traffic Control Devices" (TMUTCD) typical application diagrams or TCP Standard Sheets.

Δ Minimum distance from work area to first Advance Warning sign nearest the work area and/or distance between each additional sign.

#### GENERAL NOTES

- Special or larger size signs may be used as necessary.
- Distance between signs should be increased as required to have 1500 feet advance warning.
- Distance between signs should be increased as required to have 1/2 mile or more advance warning.
- 36" x 36" "ROAD WORK AHEAD" (CW20-1D) signs may be used on low volume crossroads at the discretion of the Engineer. See Note 2 under "Typical Location of Crossroad Signs".
- Only diamond shaped warning sign sizes are indicated.
- See sign size listing in "TMUTCD", Sign Appendix or the "Standard Highway Sign Designs for Texas" manual for complete list of available sign design sizes.

DISCLAIMER: The use of any standard is governed by the "Texas Engineering Practice Act". No warranty of any kind is made by TxDOT for any product. TxDOT assumes no responsibility for the conversion of this standard to other formats or for incorrect results or damages resulting from its use.

### WORK AREAS IN MULTIPLE LOCATIONS WITHIN CSJ LIMITS

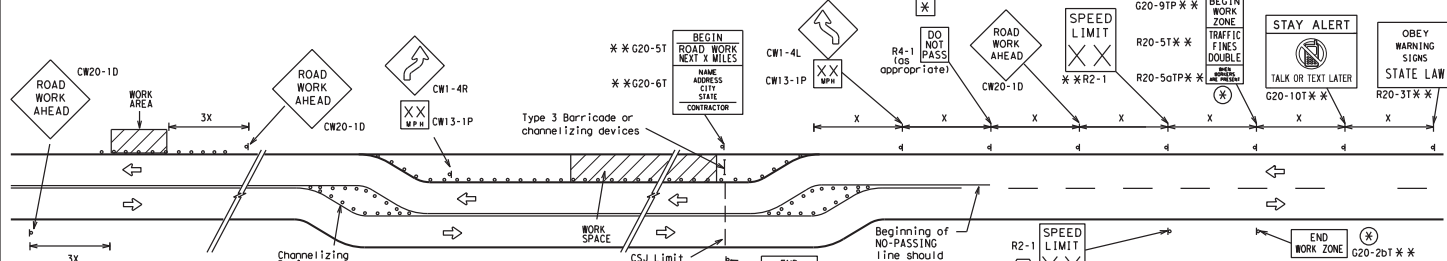

When extended distances occur between minimal work spaces, the Engineer/Inspector should ensure additional "ROAD WORK AHEAD" (CW20-1D) signs are placed in advance of these work areas to remind drivers they are still within the project limits. See the applicable TCP sheets for exact location and spacing of signs and channelizing devices.

### SAMPLE LAYOUT OF SIGNING FOR WORK BEGINNING DOWNSTREAM OF THE CSJ LIMITS

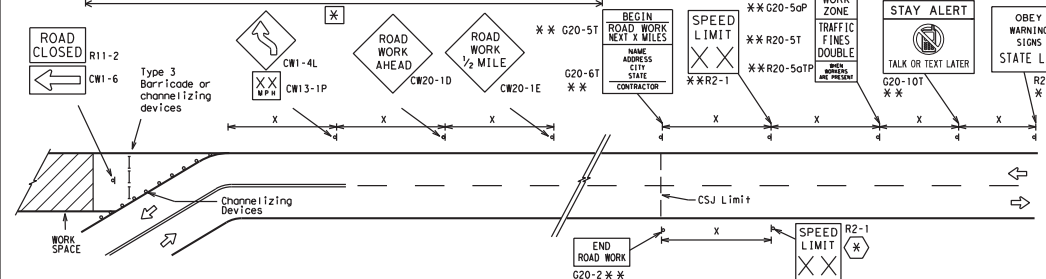

#### NOTES

- The Contractor shall determine the appropriate distance to be placed on the G20-1 series signs and "BEGIN ROAD WORK NEXT X MILES" (G20-5T) sign for each specific project. This distance shall replace the "X" and shall be rounded to the nearest whole mile with the approval of the Engineer. No decimals shall be used.
- (\*) The "BEGIN WORK ZONE" (G20-9TP) and "END WORK ZONE" (G20-2bT) shall be used as shown on the sample layout when advance signs are required outside the CSJ Limits. They inform the motorist of entering or leaving a part of the work zone lying outside the CSJ Limits where traffic fines may double if workers are present.
- \*\* Required CSJ Limit signing. See Note 10 on BC(1). TRAFFIC FINES DOUBLE signs will not be required on projects consisting solely of mobile operations work.
- (X) Area for placement of "ROAD WORK AHEAD" (CW20-1D) sign and other signs or devices as called for on the Traffic Control Plan.
- (\*) Contractor will install a regulatory speed limit sign at the end of the work zone.

LEGEND	
	Type 3 Barricade
	Channelizing Devices
	Sign
	See Typical Construction Warning Sign Size and Spacing chart or the TMUTCD for sign spacing requirements.

SHEET 2 OF 12

Texas Department of Transportation Traffic Operations Division Standard

## BARRICADE AND CONSTRUCTION PROJECT LIMIT

BC(2) - 14

FILE: bc-14.dgn	DW: TxDOT	CK: TxDOT	DN: TxDOT	CK: TxDOT
© TxDOT November 2002	CONT	SECT	JOB	HIGHWAY
REVISIONS	6379	46	001	SH 320, ETC
9-07 8-14	DIST	COUNTY	SHEET NO.	
7-13	WACO	FALLS	10	

DATE: 3/23/2021 9:44:39 AM FILE: T:\WACMAINT\TVC\Contr\c018\Bose\01\Ture\_P\wmtg\m\fy-2022\FALLS\CAD\SHEETS\STANDARDS\bc-14.dgn

## TYPICAL APPLICATION OF WORK ZONE SPEED LIMIT SIGNS

Work zone speed limits shall be regulatory, established in accordance with the "Procedures for Establishing Speed Zones," and approved by the Texas Transportation Commission, or by City Ordinance when within Incorporated City Limits.

Reduced speeds should only be posted in the vicinity of work activity and not throughout the entire project. Regulatory work zone speed signs (R2-1) shall be removed or covered during periods when they are not needed.

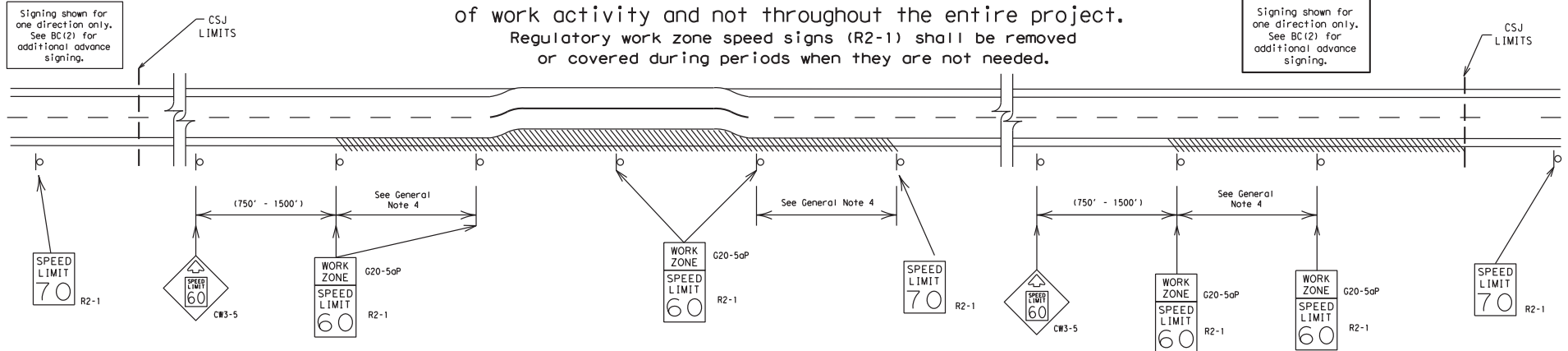

### GUIDANCE FOR USE:

#### LONG/INTERMEDIATE TERM WORK ZONE SPEED LIMITS

This type of work zone speed limit should be included on the design of the traffic control plans when restricted geometrics with a lower design speed are present in the work zone and modification of the geometrics to a higher design speed is not feasible.

Long/Intermediate Term Work Zone Speed Limit signs, when approved as described above, should be posted and visible to the motorist when work activity is present. Work activity may also be defined as a change in the roadway that requires a reduced speed for motorists to safely negotiate the work area, including:

- a) rough road or damaged pavement surface
- b) substantial alteration of roadway geometrics (diversions)
- c) construction detours
- d) grade
- e) width
- f) other conditions readily apparent to the driver

As long as any of these conditions exist, the work zone speed limit signs should remain in place.

#### SHORT TERM WORK ZONE SPEED LIMITS

This type of work zone speed limit may be included on the design of the traffic control plans when workers or equipment are not behind concrete barrier, when work activity is within 10 feet of the traveled way or actually in the travelled way.

Short Term Work Zone Speed Limit signs should be posted and visible to the motorists only when work activity is present. When work activity is not present, signs shall be removed or covered. (See Removing or Covering on BC(4)).

#### GENERAL NOTES

1. Regulatory work zone speed limits should be used only for sections of construction projects where speed control is of major importance.
2. Regulatory work zone speed limit signs shall be placed on supports at a 7 foot minimum mounting height.
3. Speed zone signs are illustrated for one direction of travel and are normally posted for each direction of travel.
4. Frequency of work zone speed limit signs should be:
  - 40 mph and greater      0.2 to 2 miles
  - 35 mph and less         0.2 to 1 mile
5. Regulatory speed limit signs shall have black legend and border on a white reflective background (See "Reflective Sheeting" on BC(4)).
6. Fabrication, erection and maintenance of the "ADVANCE SPEED LIMIT" (CW3-5) sign, "WORK ZONE" (G20-5aP) plaque and the "SPEED LIMIT" (R2-1) signs shall not be paid for directly, but shall be considered subsidiary to Item 502.
7. Turning signs from view, laying signs over or down will not be allowed, unless as otherwise noted under "REMOVING OR COVERING" on BC(4).
8. Techniques that may help reduce traffic speeds include but are not limited to:
  - A. Law enforcement.
  - B. Flagger stationed next to sign.
  - C. Portable changeable message sign (PCMS).
  - D. Low-power (drone) radar transmitter.
  - E. Speed monitor trailers or signs.
9. Speeds shown on details above are for illustration only. Work Zone Speed Limits should only be posted as approved for each project.
10. For more specific guidance concerning the type of work, work zone conditions and factors impacting allowable regulatory construction speed zone reduction see TxDOT form #1204 in the TxDOT e-form system.

DISCLAIMER: The use of this standard is governed by the "Texas Engineering Practice Act". No warranty of any kind is made by the provider of this standard to other formats or for incorrect results or damages resulting from its use.

DATE: 3/23/2021 9:44:40 AM  
 FILE: T:\MACMAINT\1-RMC-Contr\0218\Bosef01\ure-P\mt\m\1\FY-2022\FALLS\CADD\SHEETS\STANDARDS\bc-14.dgn

SHEET 3 OF 12

		Traffic Operations Division Standard	
BARRICADE AND CONSTRUCTION WORK ZONE SPEED LIMIT			
BC (3) - 14			
FILE: dc-14.dgn	DN: TxDOT	CR: TxDOT	DR: TxDOT
© TxDOT November 2002	CONT SECT	JOB	HIGHWAY
REVISIONS	6379 46	001	SH 320, ETC
9-07	8-14	DIST	COUNTY
7-13		WACO	FALLS
			SHEET NO. 11

**TYPICAL MINIMUM CLEARANCES FOR LONG TERM AND INTERMEDIATE TERM SIGNS**

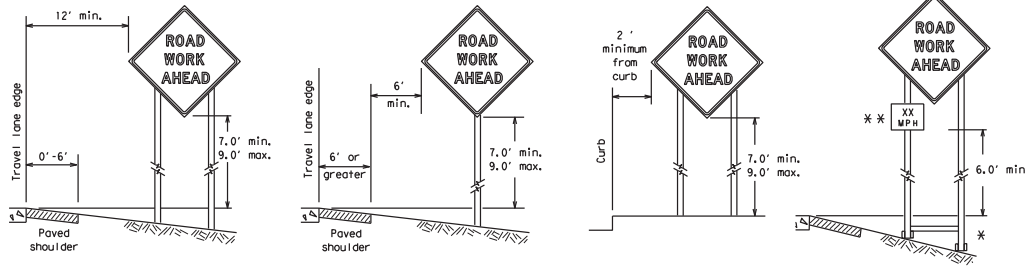

\* When placing skid supports on unlevel ground, the leg post lengths must be adjusted so the sign appears straight and plumb. Objects shall NOT be placed under skids as a means of leveling.

\*\* When plaques are placed on dual-leg supports, they should be attached to the upright nearest the travel lane. Supplemental plaques (advisory or distance) should not cover the surface of the parent sign.

**ATTACHMENT FOR SIGN SUPPORTS**

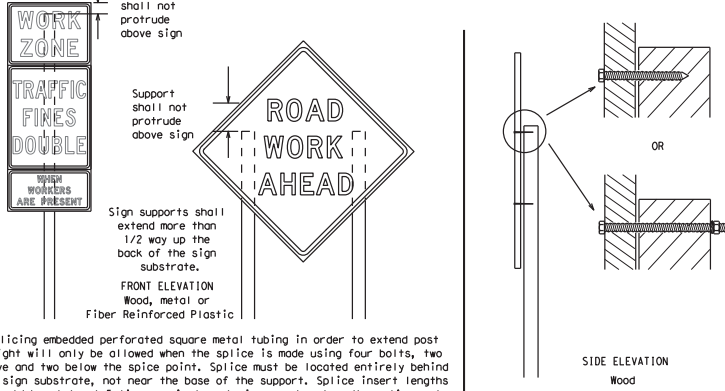

Splicing embedded perforated square metal tubing in order to extend post height will only be allowed when the splice is made using four bolts, two above and two below the splice point. Splice must be located entirely behind the sign substrate, not near the base of the support. Splice insert lengths should be at least 5 times nominal post size, centered on the splice and of at least the same gauge material.

**STOP/SLOW PADDLES**

1. STOP/SLOW paddles are the primary method to control traffic by flaggers. The STOP/SLOW paddle size should be 24" x 24" as detailed below.
2. When used at night, the STOP/SLOW paddle shall be retroreflectORIZED.
3. STOP/SLOW paddles may be attached to a staff with a minimum length of 6" to the bottom of the sign.
4. Any lights incorporated into the STOP or SLOW paddle faces shall only be as specifically described in Section 6E.03 Hand Signaling Devices in the TMUTCD.

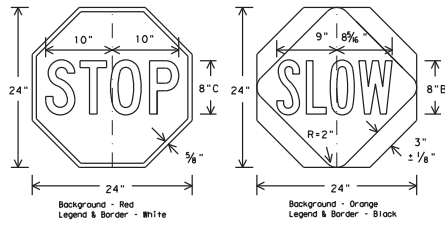

Background - Red Legend & Border - White  
Background - Orange Legend & Border - Black

**CONTRACTOR REQUIREMENTS FOR MAINTAINING PERMANENT SIGNS WITHIN THE PROJECT LIMITS**

1. Permanent signs are used to give notice of traffic laws or regulations, call attention to conditions that are potentially hazardous to traffic operations, show route designations, destinations, directions, distances, services, points of interest, and other geographical, recreational, or cultural information. Drivers proceeding through a work zone need the same, if not better route guidance as normally installed on a roadway without construction.
2. When permanent regulatory or warning signs conflict with work zone conditions, remove or cover the permanent signs until the permanent sign message matches the roadway condition.
3. When existing permanent signs are moved and relocated due to construction purposes, they shall be visible to motorists of all files.
4. If existing signs are to be relocated on their original supports, they shall be installed on crashworthy bases as shown on the SMD Standard sheets. The signs shall meet the required mounting heights shown on the BC Sheets or the SMD Standards. This work should be paid for under the appropriate pay item for relocating existing signs.
5. If permanent signs are to be removed and relocated using temporary supports, the Contractor shall use crashworthy supports as shown on the BC sheets or the CWZCD. The signs shall meet the required mounting heights shown on the BC Sheets or the SMD Standards during construction. This work should be paid for under the appropriate pay item for relocating existing signs.
6. Any sign or traffic control device that is struck or damaged by the Contractor or his/her construction equipment shall be replaced as soon as possible by the Contractor to ensure proper guidance for the motorists. This will be subsidiary to Item 502.

**GENERAL NOTES FOR WORK ZONE SIGNS**

1. Contractor shall install and maintain signs in a straight and plumb condition and/or as directed by the Engineer.
2. Wooden sign posts shall be painted white.
3. Barricades shall NOT be used as sign supports.
4. All signs shall be installed in accordance with the plans or as directed by the Engineer. Signs shall be used to regulate, warn, and guide the traveling public safely through the work zone.
5. The Contractor may furnish either the sign design shown in the plans or in the "Standard Highway Sign Designs for Texas" (SHSD). The Engineer/Inspector may require the Contractor to furnish other work zone signs that are shown in the TMUTCD but may have been omitted from the plans. Any variation in the plans shall be documented by written agreement between the Engineer and the Contractor's Responsible Person. All changes must be documented in writing before being implemented. This can include documenting the changes in the Inspector's TxDOT diary and having both the Inspector and Contractor initial and date the agreed upon changes.
6. The Contractor shall furnish sign supports listed in the "Compliant Work Zone Traffic Control Device List" (CWZTCD). The Contractor shall install the sign support in accordance with the manufacturer's recommendations. If there is a question regarding installation procedures, the Contractor shall furnish the Engineer a copy of the manufacturer's installation recommendations so the Engineer can verify the correct procedures are being followed.
7. The Contractor is responsible for installing signs on approved supports and replacing signs with damaged or cracked substrates and/or damaged or marred reflective sheeting as directed by the Engineer/Inspector.
8. Identification markings may be shown only on the back of the sign substrate. The maximum height of letters and/or company logos used for identification shall be 1 inch.
9. The Contractor shall replace damaged wood posts. New or damaged wood sign posts shall not be spliced.

**DURATION OF WORK (as defined by the "Texas Manual on Uniform Traffic Control Devices" Part 6)**

1. The types of sign supports, sign mounting height, the size of signs, and the type of sign substrates can vary based on the type of work being performed. The Engineer is responsible for selecting the appropriate size sign for the type of work being performed. The Contractor is responsible for ensuring the sign support, sign mounting height and substrate meets manufacturer's recommendations in regard to crashworthy bases and duration of work zone requirements.
  - a. Long-term stationary - work that occupies a location more than 3 days.
  - b. Intermediate-term stationary - work that occupies a location more than one daylight period up to 3 days, or nighttime work lasting more than one hour.
  - c. Short-term stationary - daytime work that occupies a location for more than 1 hour in a single daylight period.
  - d. Short, duration - work that occupies a location up to 1 hour.
  - e. Mobile - work that moves continuously or intermittently (stopping for up to approximately 15 minutes.)

**SIGN MOUNTING HEIGHT**

1. The bottom of Long-term/Intermediate-term signs shall be at least 7 feet, but not more than 9 feet, above the paved surface, except as shown for supplemental plaques mounted below other signs.
2. The bottom of Short-term/Short Duration signs shall be a minimum of 1 foot above the pavement surface but no more than 2 feet above the ground.
3. Long-term/Intermediate-term Signs may be used in lieu of Short-term/Short Duration signing.
4. Short-term/Short Duration signs shall be used only during daylight and shall be removed at the end of the workday or raised to appropriate Long-term/Intermediate sign height.
5. Regulatory signs shall be mounted at least 7 feet, but not more than 9 feet, above the paved surface regardless of work duration.

**SIZE OF SIGNS**

1. The Contractor shall furnish the sign sizes shown on BC (2) unless otherwise shown in the plans or as directed by the Engineer.

**SIGN SUBSTRATES**

1. The Contractor shall ensure the sign substrate is installed in accordance with the manufacturer's recommendations for the type of sign support that is being used. The CWZTCD lists each substrate that can be used on the different types and models of sign supports.
2. "Mesh" type materials are NOT an approved sign substrate, regardless of the tightness of the weave.
3. All wooden individual sign panels fabricated from 2 or more pieces shall have one or more plywood cleat, 1/2" thick by 6" wide, fastened to the back of the sign and extending fully across the sign. The cleat shall be attached to the back of the sign using wood screws that do not penetrate the face of the sign panel. The screws shall be placed on both sides of the splice and spaced at 6" centers. The Engineer may approve other methods of splicing the sign face.

**REFLECTIVE SHEETING**

1. All signs shall be retroreflective and constructed of sheeting meeting the color and retro-reflectivity requirements of DMS-8300 for rigid signs or DMS-8310 for roll-up signs. The web address for DMS specifications is shown on BC(1).
2. White sheeting, meeting the requirements of DMS-8300 Type A, shall be used for signs with a white background.
3. Orange sheeting, meeting the requirements of DMS-8300 Type B<sub>L</sub> or Type C<sub>L</sub>, shall be used for rigid signs with orange backgrounds.

**SIGN LETTERS**

1. All sign letters and numbers shall be clear, and open rounded type uppercase alphabet letters as approved by the Federal Highway Administration (FHWA) and as published in the "Standard Highway Sign Design for Texas" manual. Signs, letters and numbers shall be of first class workmanship in accordance with Department Standards and Specifications.

**REMOVING OR COVERING**

1. When sign messages may be confusing or do not apply, the signs shall be removed or completely covered.
2. Long-term stationary or intermediate stationary signs installed on square metal tubing may be turned away from traffic 90 degrees when the sign message is not applicable. This technique may not be used for signs installed in the median of divided highways or near any intersections where the sign may be seen from approaching traffic.
3. Signs installed on wooden skids shall not be turned at 90 degree angles to the roadway. These signs should be removed or completely covered when not required.
4. When signs are covered, the material used shall be opaque, such as heavy mil black plastic, or other materials which will cover the entire sign face and maintain their opaque properties under automobile headlights at night, without damaging the sign sheeting.
5. Burlap shall NOT be used to cover signs.
6. Duct tape or other adhesive material shall NOT be affixed to a sign face.
7. Signs and anchor studs shall be removed and holes backfilled upon completion of work.

**SIGN SUPPORT WEIGHTS**

1. Where sign supports require the use of weights to keep from turning over, the use of sandbags with dry, cohesionless sand should be used.
2. The sandbags will be tied shut to keep the sand from spilling and to maintain a constant weight.
3. Rock, concrete, iron, steel or other solid objects shall not be permitted for use as sign support weights.
4. Sandbags should weigh a minimum of 35 lbs and a maximum of 50 lbs.
5. Sandbags shall be made of a durable material that tears upon vehicular impact. Rubber (such as tire inner tubes) shall NOT be used.
6. Rubber bollards designed for channelizing devices should not be used for ballast on sign supports. Sign supports designed and manufactured with rubber bases may be used when shown on the CWZTCD list.
7. Sandbags shall only be placed along or laid over the base supports of the traffic control device and shall not be suspended above ground level or hung with rope, wire, chains or other fasteners. Sandbags shall be placed along the length of the skids to weigh down the sign support.
8. Sandbags shall NOT be placed under the skid and shall not be used to level sign supports placed on slopes.

**FLAGS ON SIGNS**

1. Flags may be used to draw attention to warning signs. When used the flag shall be 16 inches square or larger and shall be orange or fluorescent red-orange in color. Flags shall not be allowed to cover any portion of the sign face.

SHEET 4 OF 12

<p><b>BARRICADE AND CONSTRUCTION TEMPORARY SIGN NOTES</b></p> <p><b>BC (4) - 14</b></p>			
FILE:	DC-14.dgn	DN:	TxDOT
REVISED:	November 2002	CON:	6379
REVISIONS:		SECT:	46
		JOB:	001
		SH:	320, ETC
9-07	8-14	DIST:	COUNTY
7-13		WACO:	FALLS
			SHEET NO.
			12

DISCLAIMER: This standard is governed by the "Texas Engineering Practice Act". No warranty of any kind is made by TxDOT for any purpose whatsoever. TxDOT assumes no responsibility for the conversion of this standard to other formats or for incorrect results or damages resulting from its use.

DATE: 3/23/2021 9:44:40 AM  
 FILE: T:\MACMINTY\TMC\Contractors\Bases\01\ure\_Pvm\MatIn\FY-2022\FALLS\CA\ADD\SHEETS\STANDARDS\DC-14.dgn



DISCLAIMER: This standard is governed by the "Texas Engineering Practices Act". No warranty of any kind is made by TxDOT for any purpose whatsoever. TxDOT assumes no responsibility for the conversion of this standard to other formats or for incorrect results or damages resulting from its use.

DATE: 3/23/2021 9:44:41 AM  
 FILE: T:\WACMAINT\T-RMC\Contr\accrs\Bases\01\lure\_Pvm\Main\lure-2022\FALLS\CADD\SHEETS\STANDARDS\bc-14.dgn

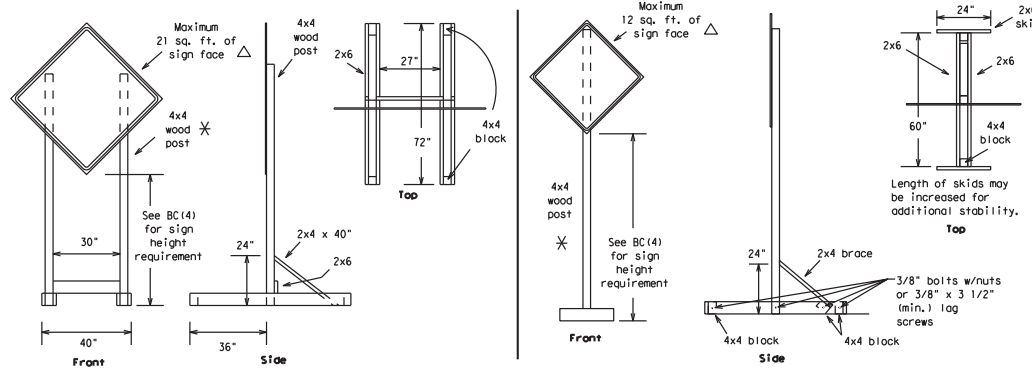

**SKID MOUNTED WOOD SIGN SUPPORTS**

LONG/INTERMEDIATE TERM STATIONARY - PORTABLE SKID MOUNTED SIGN SUPPORTS □

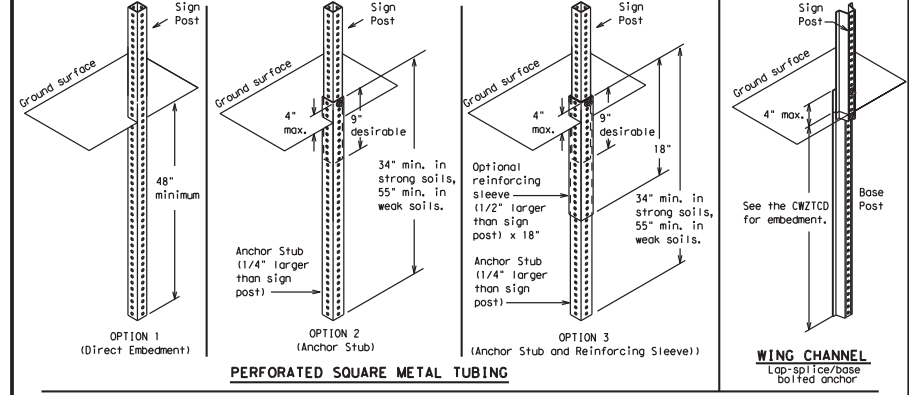

**GROUND MOUNTED SIGN SUPPORTS**

Refer to the CWZTCD and the manufacturer's installation procedure for each type sign support. The maximum sign square footage shall adhere to the manufacturer's recommendation. Two post installations can be used for larger signs.

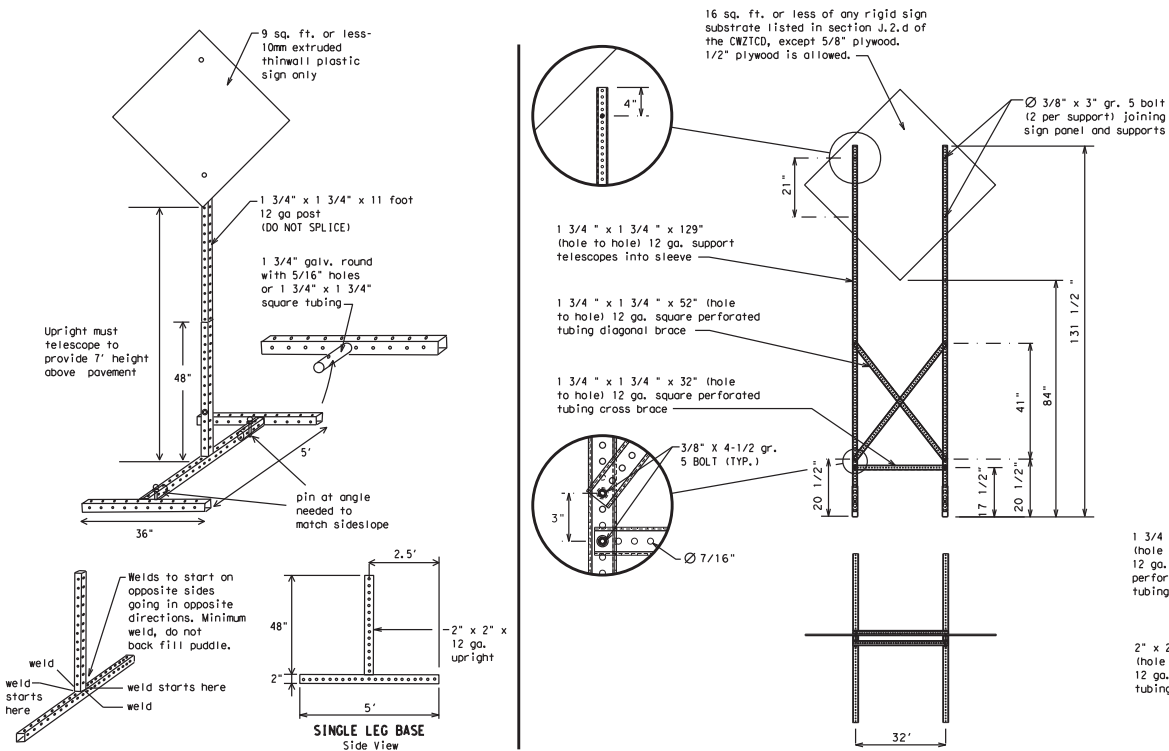

**SKID MOUNTED PERFORATED SQUARE STEEL TUBING SIGN SUPPORTS**

**WOOD POST SYSTEM FOR GROUND MOUNTED SIGN SUPPORTS**

Nominal Post Size	Number of Posts	Maximum Sq. feet of Sign Face	Minimum Soil Embedment	Drilled Holes(s) Required
4 x 4	1	12	36"	NO
4 x 4	2	21	36"	NO
4 x 6	1	21	36"	YES
4 x 6	2	36	36"	YES

**WEDGE ANCHORS**  
 Both steel and plastic Wedge Anchor Systems as shown on the SMD Standard Sheets may be used as temporary sign supports for signs up to 10 square feet of sign face. They may be set in concrete or in sturdy soils if approved by the Engineer. (See web address for "Traffic Engineering Standard Sheets" on BC(1)).

**OTHER DESIGNS**  
 MORE DETAILS OF APPROVED LONG/INTERMEDIATE AND SHORT TERM SUPPORTS CAN BE FOUND ON THE CWZTCD LIST. SEE BC(1) FOR WEBSITE LOCATION.

**GENERAL NOTES**

- Nails may be used in the assembly of wooden sign supports, but 3/8" bolts with nuts or 3/8" x 3 1/2" lag screws must be used on every joint for final connection.
- No more than 2 sign posts shall be placed within a 7 ft. circle, except for specific materials noted on the CWZTCD List.
- When project is completed, all sign supports and foundations shall be removed from the project site. This will be considered subsidiary to Item 502.

□ See BC(4) for definition of "Work Duration."  
 ✕ Wood sign posts MUST be one piece. Splicing will NOT be allowed. Posts shall be painted white.  
 △ See the CWZTCD for the type of sign substrate that can be used for each approved sign support.

SHEET 5 OF 12

**BARRICADE AND CONSTRUCTION TYPICAL SIGN SUPPORT**

**BC(5) - 14**

FILE:	bc-14.dgn	DNV:	TxDOT	CHK:	TxDOT	DRW:	TxDOT	CHK:	TxDOT
©:	TxDOT	REVISIONS:	6379	46	001	SH	320, ETC		
	9-07	8-14	DIST:	7-13	COUNTY:	WACO	FALLS	SHEET NO.:	13

WHEN NOT IN USE, REMOVE THE PCMS FROM THE RIGHT-OF-WAY OR PLACE THE PCMS BEHIND BARRIER OR GUARDRAIL WITH SIGN PANEL TURNED PARALLEL TO TRAFFIC

**PORTABLE CHANGEABLE MESSAGE SIGNS**

- The Engineer/Inspector shall approve all messages used on portable changeable message signs (PCMS).
- Messages on PCMS should contain no more than 8 words (about four to eight characters per word), not including simple words such as "TO," "FOR," "AT," etc.
- Messages should consist of a single phase, or two phases that alternate. Three-phase messages are not allowed. Each phase of the message should convey a single thought, and must be understood by itself.
- Use the word "EXIT" to refer to an exit ramp on a freeway; i.e., "EXIT CLOSED." Do not use the term "RAMP."
- Always use the route or interstate designation (IH, US, SH, FM) along with the number when referring to a roadway.
- When in use the bottom of a stationary PCMS message panel should be a minimum 7 feet above the roadway, where possible.
- The message term "WEEKEND" should be used only if the work is to start on Saturday morning and end by Sunday evening at midnight. Actual days and hours of work should be displayed on the PCMS if work is to begin on Friday evening and/or continue into Monday morning.
- The Engineer/Inspector may select one of two options which are available for displaying a two-phase message on a PCMS. Each phase may be displayed for either four seconds each or for three seconds each. Do not "Flash" messages or words included in a message. The message should be steady burn or continuous while displayed.
- Do not present redundant information on a two-phase message; i.e., keeping two lines of the message the same and changing the third line.
- Do not use the word "Danger" in message.
- Do not display the message "LANES SHIFT LEFT" or "LANES SHIFT RIGHT" on a PCMS. Drivers do not understand the message.
- Do not display messages that scroll horizontally or vertically across the face of the sign.
- The following table lists abbreviated words and two-word phrases that are acceptable for use on a PCMS. Both words in a phrase must be displayed together. Words or phrases not on this list should not be abbreviated, unless shown in the TMIU list.
- PCMS character height should be at least 18 inches for trailer mounted units. They should be visible from at least 1/2 (.5) mile and the text should be legible from at least 600 feet at night and 800 feet in daylight. Truck mounted units must have a character height of 10 inches and must be legible from at least 400 feet.
- Each line of text should be centered on the message board rather than left or right justified.
- If disabled, the PCMS should default to an illegible display that will not alarm motorists and will only be used to alert workers that the PCMS has malfunctioned. A pattern such as a series of horizontal solid bars is appropriate.

**RECOMMENDED PHASES AND FORMATS FOR PCMS MESSAGES DURING ROADWORK ACTIVITIES**

(The Engineer may approve other messages not specifically covered here.)

**Phase 1: Condition Lists**

**Road/Lane/Ramp Closure List**

FREEWAY CLOSED X MILE	FRONTAGE ROAD CLOSED
ROAD CLOSED AT SH XXX	SHOULDER CLOSED XXX FT
ROAD CLSD AT FM XXXX	RIGHT LN CLOSED XXX FT
RIGHT X LANES CLOSED	RIGHT X LANES OPEN
CENTER LANE CLOSED	DAYTIME LANE CLOSURES
NIGHT LANE CLOSURES	I-XX SOUTH EXIT CLOSED
VARIOUS LANES CLOSED	EXIT XXX CLOSED X MILE
EXIT CLOSED	RIGHT LN TO BE CLOSED
MALL DRIVEWAY CLOSED	X LANES CLOSED TUE - FRI
XXXXXXXX BLVD CLOSED	

**Other Condition List**

ROADWORK XXX FT	ROAD REPAIRS XXXX FT
FLAGGER XXXX FT	LANE NARROWS XXXX FT
RIGHT LN CLOSED XXXX FT	TWO-WAY TRAFFIC XX MILE
MERGING TRAFFIC XXXX FT	CONST TRAFFIC XXX FT
LOOSE GRAVEL XXXX FT	UNEVEN LANES XXXX FT
ROADWORK PAST SH XXXX	ROADWORK NEXT FRI-SUN
BUMP XXXX FT	US XXX EXIT X MILES
TRAFFIC SIGNAL XXXX FT	LANES SHIFT *

\* LANES SHIFT in Phase 1 must be used with STAY IN LANE in Phase 2.

**Phase 2: Possible Component Lists**

**Action to Take/Effect on Travel List**

MERGE RIGHT	FORM X LANES RIGHT
DETOUR NEXT X EXITS	USE XXXX RD EXIT
USE EXIT XXX	USE EXIT I-XX NORTH
STAY ON US XXX SOUTH	USE I-XX E TO I-XX N
TRUCKS USE US XXX N	WATCH FOR TRUCKS
WATCH FOR TRUCKS	EXPECT DELAYS
EXPECT DELAYS	PREPARE TO STOP
REDUCE SPEED XXX FT	END SHOULDER USE
USE OTHER ROUTES	WATCH FOR WORKERS
STAY IN LANE *	

**Location List**

AT FM XXXX	BEFORE RAILROAD CROSSING	NEXT X MILES	PAST US XXX EXIT	XXXXXXXX TO XXXXXXX	US XXX TO FM XXXX
------------	--------------------------	--------------	------------------	---------------------	-------------------

**Warning List**

SPEED LIMIT XX MPH	MAXIMUM SPEED XX MPH	MINIMUM SPEED XX MPH	ADVISORY SPEED XX MPH	RIGHT LANE EXIT	USE CAUTION	DRIVE SAFELY	DRIVE WITH CARE
--------------------	----------------------	----------------------	-----------------------	-----------------	-------------	--------------	-----------------

**\*\* Advance Notice List**

TUE-FRI XX AM - X PM	APR XX - XX PM - X AM	BEGINS MONDAY	BEGINS MAY XX	MAY X-X XX PM - XX AM	NEXT FRI-SUN	XX AM TO XX PM	NEXT TUE AUG XX	TONIGHT XX PM - XX AM
----------------------	-----------------------	---------------	---------------	-----------------------	--------------	----------------	-----------------	-----------------------

\*\* See Application Guidelines Note 6.

**APPLICATION GUIDELINES**

- Only 1 or 2 phases are to be used on a PCMS.
- The 1st phase (or both) should be selected from the "Road/Lane/Ramp Closure List" and the "Other Condition List".
- A 2nd phase can be selected from the "Action to Take/Effect on Travel, Location, General Warning, or Advance Notice Phase Lists".
- A Location Phase is necessary only if a distance or location is not included in the first phase selected.
- If two PCMS are used in sequence, they must be separated by a minimum of 1000 ft. Each PCMS shall be limited to two phases, and should be understandable by themselves.
- For advance notice, when the current date is within seven days of the actual work date, calendar days should be replaced with days of the week. Advance notification should typically be for no more than one week prior to the work.

**WORDING ALTERNATIVES**

- The words RIGHT, LEFT and ALL can be interchanged as appropriate.
- Roadway designations IH, US, SH, FM and LP can be interchanged as appropriate.
- EAST, WEST, NORTH and SOUTH (or abbreviations E, W, N and S) can be interchanged as appropriate.
- Highway names and numbers replaced as appropriate.
- ROAD, HIGHWAY and FREEWAY can be interchanged as needed.
- AHEAD may be used instead of distances if necessary.
- FT and MI, MILE and MILES interchanged as appropriate.
- AT, BEFORE and PAST interchanged as needed.
- Distances or AHEAD can be eliminated from the message if a location phase is used.

PCMS SIGNS WITHIN THE R.O.W. SHALL BE BEHIND GUARDRAIL OR CONCRETE BARRIER OR SHALL HAVE A MINIMUM OF FOUR (4) PLASTIC DRUMS PLACED PERPENDICULAR TO TRAFFIC ON THE UPSTREAM SIDE OF THE PCMS, WHEN EXPOSED TO ONE DIRECTION OF TRAFFIC. WHEN EXPOSED TO TWO WAY TRAFFIC, THE FOUR DRUMS SHOULD BE PLACED WITH ONE DRUM AT EACH OF THE FOUR CORNERS OF THE UNIT.

**FULL MATRIX PCMS SIGNS**

- When Full Matrix PCMS signs are used, the character height and legibility/visibility requirements shall be maintained as listed in Note 15 under "PORTABLE CHANGEABLE MESSAGE SIGNS" above.
- When symbol signs, such as the "Flagger Symbol" (CW20-7) are represented graphically on the Full Matrix PCMS sign and, with the approval of the Engineer, it shall maintain the legibility/visibility requirement listed above.
- When symbol signs are represented graphically on the Full Matrix PCMS, they shall only supplement the use of the static sign represented, and shall not substitute for, or replace that sign.
- A full matrix PCMS may be used to simulate a flashing arrow board provided it meets the visibility, flash rate and dimming requirements on BC(7), for the same size arrow.

DISCLAIMER: This standard is governed by the "Texas Engineering Practice Act". No warranty of any kind is made by TxDOT for any purpose whatsoever. TxDOT assumes no responsibility for the conversion of this standard to other formats or for inaccurate results or damages resulting from its use.

DATE: 3/23/2021 9:44:42 AM FILE: T:\MCM\INT\...RMC-Contr\Facets\Bases\G1\ure-P\m\Mat\m\FY-2022\FALLS\CADD\SHEETS\STANDARDS-14.dgn

WORD OR PHRASE	ABBREVIATION	WORD OR PHRASE	ABBREVIATION
Access Road	ACCS RD	Major	MAJ
Alternate	ALT	Miles	MI
Avenue	AVE	Miles Per Hour	MPH
Best Route	BEST RTE	Minor	MNR
Boulevard	BLVD	Monday	MON
Bridge	BRDG	Normal	NORM
Cannot	CANT	North	N
Center	CTR	Northbound (route) N	
Construction Ahead	CONST AHD	Parking	PKING
CROSSING	XING	Road	RD
Detour Route	DETOUR RTE	Right Lane	RT LN
Do Not	DONT	Saturday	SAT
East	E	Service Road	SERV RD
Eastbound (route) E		Shoulder	SHLDR
Emergency	EMER	Slippery	SLIP
Emergency Vehicle	EMER VEH	South	S
Entrance, Enter	ENT	Southbound (route) S	
Express Lane	EXP LN	Speed	SPD
Expressway	EXPWY	Street	ST
XXXX Feet	XXXX FT	Sunday	SUN
Fog Ahead	FOG AHD	Telephone	PHONE
Freeway	FRWY, FWY	Temporary	TEMP
Freeway Blocked	FWY BLKD	Thursday	THURS
Friday	FRI	To Downtown	TO DOWNTN
Hazardous Driving	HAZ DRIVING	Traffic	TRAF
Hazardous Material	HAZMAT	Travelers	TRVLRS
High Occupancy	HOV	Tuesday	TUES
Vehicle Highway	HWY	Time Minutes	TIME MIN
Hour(s)	HR, HRS	Upper Level	UPR LEVEL
Information	INFO	Vehicles (s)	VEH, VEHs
ITS		Warning	WARN
Junction	JCT	Wednesday	WED
Left	LFT	Weight Limit	WT LIMIT
Left Lane	LFT LN	West	W
Lane Closed	LN CLOSED	Westbound (route) W	
Lower Level	LR LEVEL	Wet Pavement	WET PVMT
Maintenance	MAINT	Will Not	WONT

Roadway designation = IH-number, US-number, SH-number, FM-number



**BARRICADE AND CONSTRUCTION PORTABLE CHANGEABLE MESSAGE SIGN (PCMS)**

**BC (6) - 14**

FILE: DC-14.dgn	DNV: TxDOT	CR: TxDOT	DMV: TxDOT	CR: TxDOT
© TxDOT November 2002	CONT: SECT	JOB: 6379	SH: 320, ETC	
REVISIONS	46	DIST: WACO	COUNTY: FALLS	SHEET NO: 14
9-07	8-14			
7-13				

- Barrier Reflectors shall be pre-qualified, and conform to the color and reflectivity requirements of DMS-8600. A list of prequalified Barrier Reflectors can be found at the Material Producer List web address shown on BC(1).
- Color of Barrier Reflectors shall be as specified in the TMUTCD. The cost of the reflectors shall be considered subsidiary to Item 512.

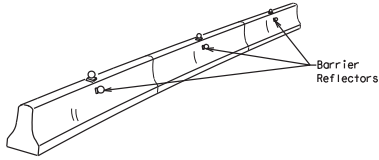

CONCRETE TRAFFIC BARRIER (CTB)

- Where traffic is on one side of the CTB, two (2) Barrier Reflectors shall be mounted in approximately the midsection of each section of CTB. An alternate mounting location is uniformly spaced at one end of each CTB. This will allow for attachment of a barrier grapple without damaging the reflector. The Barrier Reflector mounted on the side of the CTB shall be located directly below the reflector mounted on top of the barrier, as shown in the detail above.
- Where CTB separates two-way traffic, three barrier reflectors shall be mounted on each section of CTB. The reflector unit on top shall have two yellow reflective faces (Bi-Directional) while the reflectors on each side of the barrier shall have one yellow reflective face, as shown in the detail above.
- When CTB separates traffic traveling in the same direction, no barrier reflectors will be required on top of the CTB.
- Barrier Reflector units shall be yellow or white in color to match the edgeline being supplemented.
- Maximum spacing of Barrier Reflectors is forty (40) feet.
- Pavement markers or temporary flexible-reflective roadway marker tabs shall NOT be used as CTB delineation.
- Attachment of Barrier Reflectors to CTB shall be per manufacturer's recommendations.
- Missing or damaged Barrier Reflectors shall be replaced as directed by the Engineer.
- Single slope barriers shall be delineated as shown on the above detail.

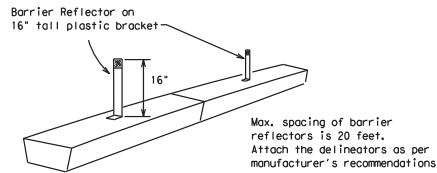

LOW PROFILE CONCRETE BARRIER (LPCB)

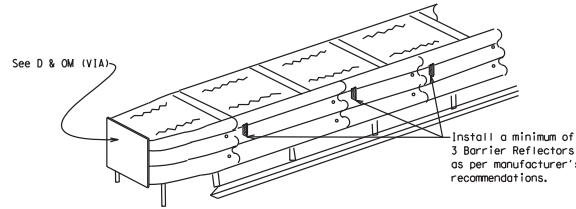

DELINEATION OF END TREATMENTS

END TREATMENTS FOR CTB'S USED IN WORK ZONES

End treatments used on CTB's in work zones shall meet crashworthy standards as defined in the National Cooperative Highway Research Report 350. Refer to the CWZTCD List for approved end treatments and manufacturers.

Arrow Boards may be located behind channelizing devices in place for a shoulder taper or merging taper, otherwise they shall be delineated with four (4) channelizing devices placed perpendicular to traffic on the upstream side of traffic.

- The Flashing Arrow Board should be used for all lane closures on multi-lane roadways, or slow moving maintenance or construction activities on the travel lanes.
- Flashing Arrow Boards should not be used on two-lane, two-way roadways, detours, diversions or work on shoulders unless the "CAUTION" display (see detail below) is used.
- The Engineer/Inspector shall choose all appropriate signs, barricades and/or other traffic control devices that should be used in conjunction with the Flashing Arrow Board.
- The Flashing Arrow Board should be able to display the following symbols:

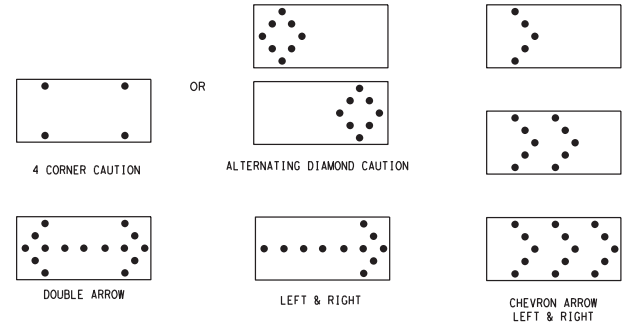

- The "CAUTION" display consists of four corner lamps flashing simultaneously, or the Alternating Diamond Caution mode as shown.
- The straight line caution display is NOT ALLOWED.
- The Flashing Arrow Board shall be capable of minimum 50 percent dimming from rated lamp voltage.
- The flashing rate of the lamps shall not be less than 25 nor more than 40 flashes per minute.
- Minimum lamp "on time" shall be approximately 50 percent for the flashing arrow and equal intervals of 25 percent for each sequential phase of the flashing chevron.
- The sequential arrow display is NOT ALLOWED.
- The flashing arrow display is the TxDOT standard; however, the sequential Chevron display may be used during daylight operations.
- The Flashing Arrow Board shall be mounted on a vehicle, trailer or other suitable support.
- A Flashing Arrow Board SHALL NOT BE USED to laterally shift traffic.
- A full matrix POMS may be used to simulate a Flashing Arrow Board provided it meets visibility, flash rate and dimming requirements on this sheet for the same size arrow.
- Minimum mounting height of trailer mounted Arrow Boards should be 7 feet from roadway to bottom of panel.

BARRIER REFLECTORS FOR CONCRETE TRAFFIC BARRIER AND ATTENUATORS

WARNING LIGHTS

- Warning lights shall meet the requirements of the TMUTCD.
- Warning lights shall NOT be installed on barricades.
- Type A-Low Intensity Flashing Warning Lights are commonly used with drums. They are intended to warn or mark a potentially hazardous area. Their use shall be as indicated on this sheet and/or other sheets of the plans by the designation "FL". The Type A Warning Lights shall not be used with signs manufactured with Type B<sub>1</sub> or C<sub>1</sub> Sheeting meeting the requirements of Departmental Material Specification DMS-8300.
- Type-C and Type D 360 degree Steady Burn Lights are intended to be used in a series for delineation to supplement other traffic control devices. Their use shall be as indicated on this sheet and/or other sheets of the plans by the designation "SB".
- The Engineer/Inspector or the plans shall specify the location and type of warning lights to be installed on the traffic control devices.
- When required by the Engineer, the Contractor shall furnish a copy of the warning lights certification. The warning light manufacturer will certify the warning lights meet the requirements of the latest ITE Purchase Specifications for Flashing and Steady-Burn Warning Lights.
- When used to delineate curves, Type-C and Type D Steady Burn Lights should only be placed on the outside of the curve, not the inside.
- The location of warning lights and warning reflectors on drums shall be as shown elsewhere in the plans.

WARNING LIGHTS MOUNTED ON PLASTIC DRUMS

- Type A flashing warning lights are intended to warn drivers that they are approaching or are in a potentially hazardous area.
- Type A random flashing warning lights are not intended for delineation and shall not be used in a series.
- A series of sequential flashing warning lights placed on channelizing devices to form a merging taper may be used for delineation. If used, the successive flashing of the sequential warning lights should occur from the beginning of the taper to the end of the merging taper in order to identify the desired vehicle path. The rate of flashing for each light shall be 65 flashes per minute, plus or minus 10 flashes.
- Type C and D steady-burn warning lights are intended to be used in a series to delineate the edge of the travel lane on detours, on lane changes, on lane closures, and on other similar conditions.
- Type A, Type C and Type D warning lights shall be installed at locations as detailed on other sheets in the plans.
- Warning lights shall not be installed on a drum that has a sign, chevron or vertical panel.
- The maximum spacing for warning lights on drums should be identical to the channelizing device spacing.

WARNING REFLECTORS MOUNTED ON PLASTIC DRUMS AS A SUBSTITUTE FOR TYPE C (STEADY BURN) WARNING LIGHTS

- A warning reflector or approved substitute may be mounted on a plastic drum as a substitute for a Type C, steady burn warning light at the discretion of the Contractor unless otherwise noted in the plans.
- The warning reflector shall be yellow in color and shall be manufactured using a sign substrate approved for use with plastic drums listed on the CWZTCD.
- The warning reflector shall have a minimum retroreflective surface area (one-side) of 30 square inches.
- Round reflectors shall be fully reflectorized, including the area where attached to the drum.
- Square substrates must have a minimum of 30 square inches of reflectorized sheeting. They do not have to be reflectorized where it attaches to the drum.
- The side of the warning reflector facing approaching traffic shall have sheeting meeting the color and retroreflectivity requirements for DMS 8300-Type B or Type C.
- When used near two-way traffic, both sides of the warning reflector shall be reflectorized.
- The warning reflector should be mounted on the side of the handle nearest approaching traffic.
- The maximum spacing for warning reflectors should be identical to the channelizing device spacing requirements.

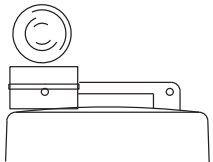

Type C Warning Light or approved substitute mounted on a drum adjacent to the travel way.

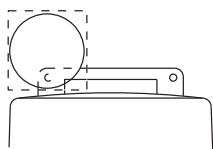

Warning reflector may be round or square. Must have a yellow reflective surface area of at least 30 square inches

REQUIREMENTS			
TYPE	MINIMUM SIZE	MINIMUM NUMBER OF PANEL LAMPS	MINIMUM VISIBILITY DISTANCE
B	30 x 60	13	3/4 mile
C	48 x 96	15	1 mile

**ATTENTION**  
Flashing Arrow Boards shall be equipped with automatic dimming devices.

WHEN NOT IN USE, REMOVE THE ARROW BOARD FROM THE RIGHT-OF-WAY OR PLACE THE ARROW BOARD BEHIND CONCRETE TRAFFIC BARRIER OR GUARDRAIL.

FLASHING ARROW BOARDS

SHEET 7 OF 12

TRUCK-MOUNTED ATTENUATORS

- Truck-mounted attenuators (TMA) used on TxDOT facilities must meet the requirements outlined in the National Cooperative Highway Research Report No. 350 (NCHRP 350) or the Manual for Assessing Safety Hardware (MASH).
- Refer to the CWZTCD for the requirements of Level 2 or Level 3 TMAs.
- Refer to the CWZTCD for a list of approved TMAs.
- TMAs are required on freeways unless otherwise noted in the plans.
- A TMA should be used anytime that it can be positioned 30 to 100 feet in advance of the area of crew exposure without adversely affecting the work performance.
- The only reason a TMA should not be required is when a work area is spread down the roadway and the work crew is an extended distance from the TMA.



Texas Department of Transportation  
Traffic Operations Division Standard

BARRICADE AND CONSTRUCTION ARROW PANEL, REFLECTORS, WARNING LIGHTS & ATTENUATOR

BC(7) - 14

FILE#	bc-14.dgn	DATE	TxDOT	CHK	TxDOT	DATE	TxDOT	CHK	TxDOT
REV#	1	DATE	NOVEMBER 2002	CONT	SECT	JOB	HIGHWAY		
				6379	46	001	SH 320, ETC		
		9-07	8-14	DIST	COUNTY		SHEET NO.		
		7-13		WACO	FALLS		15		

DISCLAIMER: This standard is governed by the "Texas Engineering Practice Act". No warranty of any kind is made by TxDOT for any purpose whatsoever. TxDOT assumes no responsibility for the conversion of this standard to other formats or for incorrect results or damages resulting from its use.

DATE: 3/23/2021 9:44:43 AM FILE: T:\MACMINTY\TMC-Contractors\BoseFol\Ture\_Pvm\MatIn\FY-2022\FALLS\CADD\SHEETS\STANDARDS\bc-14.dgn

DISCLAIMER: The use of this standard is governed by the "Texas Engineering Practice Act". No warranty of any kind is made by TxDOT for any purpose whatsoever. TxDOT assumes no responsibility for the conversion of this standard to other formats or for incorrect results or damages resulting from its use.

DATE: 3/23/2021 9:44:43 AM  
 FILE: T:\MACMAINT\TWC-Contractors\Bases\G1\ure-P\m\m\m\FY-2022\FALLS\CADD\SHEETS\STANDARDS\bc-14.dgn

**GENERAL NOTES**

- For long term stationary work zones on freeways, drums shall be used as the primary channelizing device.
- For intermediate term stationary work zones on freeways, drums should be used as the primary channelizing device but may be replaced in tangent sections by vertical panels, or 42" two-piece cones. In tangent sections one-piece cones may be used with the approval of the Engineer but only if personnel are present on the project at all times to maintain the cones in proper position and location.
- For short term stationary work zones on freeways, drums are the preferred channelizing device but may be replaced in tapers, transitions and tangent sections by vertical panels, two-piece cones or one-piece cones as approved by the Engineer.
- Drums and all related items shall comply with the requirements of the current version of the "Texas Manual on Uniform Traffic Control Devices" (TMUTCD) and the "Compliant Work Zone Traffic Control Devices List" (CWZTCD).
- Drums, bases, and related materials shall exhibit good workmanship and shall be free from objectionable marks or defects that would adversely affect their appearance or serviceability.
- The Contractor shall have a maximum of 24 hours to replace any plastic drums identified for replacement by the Engineer/Inspector. The replacement device must be an approved device.

**GENERAL DESIGN REQUIREMENTS**

Pre-qualified plastic drums shall meet the following requirements:

- Plastic drums shall be a two-piece design; the "body" of the drum shall be the top portion and the "base" shall be the bottom.
- The body and base shall lock together in such a manner that the body separates from the base when impacted by a vehicle traveling at a speed of 20 MPH or greater but prevents accidental separation due to normal handling and/or air turbulence created by passing vehicles.
- Plastic drums shall be constructed of lightweight flexible, and deformable materials. The Contractor shall NOT use metal drums or single piece plastic drums as channelization devices or sign supports.
- Drums shall present a profile that is a minimum of 18 inches in width at the 36 inch height when viewed from any direction. The height of drum unit (body installed on base) shall be a minimum of 36 inches and a maximum of 42 inches.
- The top of the drum shall have a built-in handle for easy pickup and shall be designed to drain water and not collect debris. The handle shall have a minimum of two widely spaced 9/16" inch diameter holes to allow attachment of a warning light, warning reflector unit or approved compliant sign.
- The exterior of the drum body shall have a minimum of four alternating orange and white retroreflective circumferential stripes not less than 4 inches nor greater than 8 inches in width. Any non-reflectorized space between any two adjacent stripes shall not exceed 2 inches in width.
- Bases shall have a maximum width of 36 inches, a maximum height of 4 inches, and a minimum of two footholds of sufficient size to allow base to be held down while separating the drum body from the base.
- Plastic drums shall be constructed of ultra-violet stabilized, orange, high-density polyethylene (HDPE) or other approved material.
- Drum body shall have a maximum unbolstered weight of 11 lbs.
- Drum and base shall be marked with manufacturer's name and model number.

**RETROREFLECTIVE SHEETING**

- The stripes used on drums shall be constructed of sheeting meeting the color and retroreflectivity requirements of Departmental Materials Specification DMS-8300, "Sign Face Materials." Type A reflective sheeting shall be supplied unless otherwise specified in the plans.
- The sheeting shall be suitable for use on and shall adhere to the drum surface such that, upon vehicular impact, the sheeting shall remain adhered in-place and exhibit no delaminating, cracking, or loss of retroreflectivity other than that loss due to abrasion of the sheeting surface.

**BALLAST**

- Unbolstered bases shall be large enough to hold up to 50 lbs. of sand. This base, when filled with the ballast material, should weigh between 35 lbs (minimum) and 50 lbs (maximum). The ballast may be sand in one to three sandbags separate from the base, sand in a sand-filled plastic base, or other ballasting devices as approved by the Engineer. Stacking of sandbags will be allowed, however height of sandbags above pavement surface may not exceed 12 inches.
- Bases with built-in ballast shall weigh between 40 lbs. and 50 lbs. Built-in ballast can be constructed of an integral crumb rubber base or a solid rubber base.
- Recycled truck tire sidewalls may be used for ballast on drums approved for this type of ballast on the CWZTCD list.
- The ballast shall not be heavy objects, water, or any material that would become hazardous to motorists, pedestrians, or workers when the drum is struck by a vehicle.
- When used in regions susceptible to freezing, drums shall have drainage holes in the bottoms so that water will not collect and freeze becoming a hazard when struck by a vehicle.
- Ballast shall not be placed on top of drums.
- Adhesives may be used to secure base of drums to pavement.

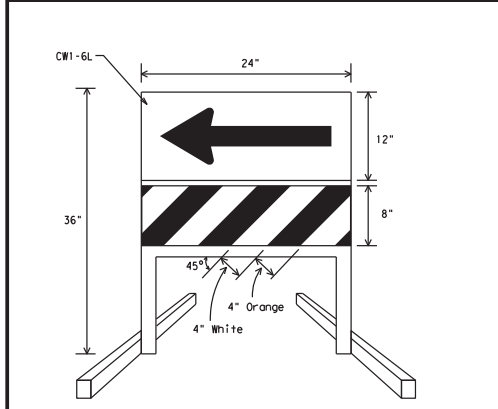
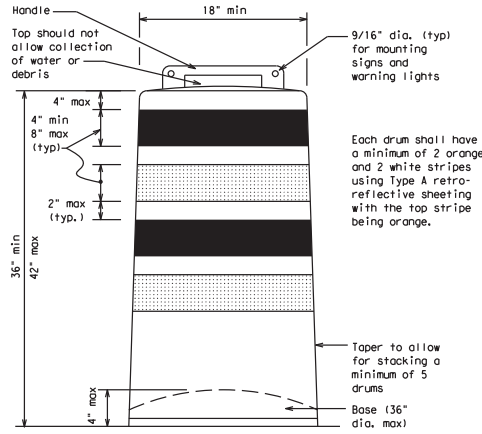

**DIRECTION INDICATOR BARRICADE**

- The Direction Indicator Barricade may be used in tapers, transitions, and other areas where specific directional guidance to drivers is necessary.
- If used, the Direction Indicator Barricade should be used in series to direct the driver through the transition and into the intended travel lane.
- The Direction Indicator Barricade shall consist of One-Direction Large Arrow (CW1-6L) sign in the side shown with a black arrow on a background of Type B<sub>FL</sub> or Type C<sub>FL</sub> Orange retroreflective sheeting above a rail with Type A retroreflective sheeting in alternating 4" white and orange stripes sloping downward at an angle of 45 degrees in the direction road users are to pass. Sheeting types shall be as per DMS 8300.
- Double arrows on the Direction Indicator Barricade will not be allowed.
- Approved manufacturers are shown on the CWZTCD List. Ballast shall be as approved by the manufacturers instructions.

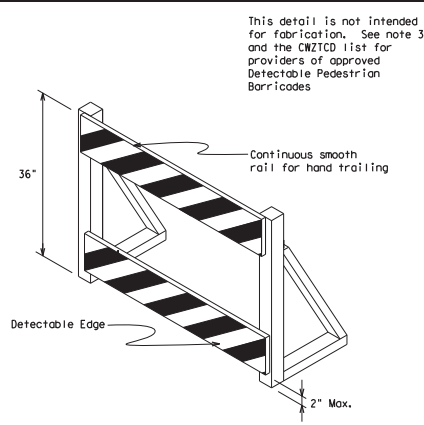

**DETECTABLE PEDESTRIAN BARRICADES**

- When existing pedestrian facilities are disrupted, closed, or relocated in a TTC zone, the temporary facilities shall be detectable and include accessibility features consistent with the features present in the existing pedestrian facility.
- Where pedestrians with visual disabilities normally use the closed sidewalk, a device that is detectable by a person with a visual disability traveling with the aid of a long cane shall be placed across the full width of the closed sidewalk.
- Detectable pedestrian barricades similar to the one pictured above, longitudinal channelizing devices, some concrete barriers, and wood or chain link fencing with a continuous detectable edging can satisfactorily delineate a pedestrian path.
- Tape, rope, or plastic chain strung between devices are not detectable, do not comply with the design standards in the "Americans with Disabilities Act Accessibility Guidelines for Buildings and Facilities (ADAAG)" and should not be used as a control for pedestrian movements.
- Warning lights shall not be attached to detectable pedestrian barricades.
- Detectable pedestrian barricades may use 8" nominal barricade rails as shown on BC(10) provided that the top rail provides a smooth continuous rail suitable for hand trailing with no splinters, burrs, or sharp edges.



18" x 24" Sign  
(Maximum Sign Dimension)  
Chevron CW1-8, Opposing Traffic Lane Divider, Driveway Sign D70a, Keep Right R4 series or other signs as approved by Engineer



12" x 24" Vertical Panel  
mount with diagonals sloping down towards travel way

**Plywood, Aluminum or Metal sign substrates shall NOT be used on plastic drums**

**SIGNS, CHEVRONS, AND VERTICAL PANELS MOUNTED ON PLASTIC DRUMS**

- Signs used on plastic drums shall be manufactured using substrates listed on the CWZTCD.
- Chevrons and other work zone signs with an orange background shall be manufactured with Type B<sub>FL</sub> or Type C<sub>FL</sub> Orange sheeting meeting the color and retroreflectivity requirements of DMS-8300, "Sign Face Material," unless otherwise specified in the plans.
- Vertical Panels shall be manufactured with orange and white sheeting meeting the requirements of DMS-8300 Type A Diagonal stripes on Vertical Panels shall slope down toward the intended traveled lane.
- Other sign messages (text or symbolic) may be used as approved by the Engineer. Sign dimensions shall not exceed 18 inches in width or 24 inches in height, except for the R9 series signs discussed in note 8 below.
- Signs shall be installed using a 1/2 inch bolt (nominal) and nut, two washers, and one locking washer for each connection.
- Mounting bolts and nuts shall be fully engaged and adequately torqued. Bolts should not extend more than 1/2 inch beyond nuts.
- Chevrons may be placed on drums on the outside of curves, on merging tapers or on shifting tapers. When used in these locations they may be placed on every drum or spaced not more than on every third drum. A minimum of three (3) should be used at each location called for in the plans.
- R9-9, R9-10, R9-11 and R9-11a Sidewalk Closed signs which are 24 inches wide may be mounted on plastic drums, with approval of the Engineer.

SHEET 8 OF 12



Traffic Operations Division  
Standard

**BARRICADE AND CONSTRUCTION CHANNELIZING DEVICES**

**BC (8) - 14**

FILE: bc-14.dgn	DN: TxDOT	CR: TxDOT	DR: TxDOT	EX: TxDOT
REVISED: November 2002	CONT: 6379	SECT: 46	JOB: 001	SH: 320, ETC
4-03 7-13	DIST: WACO	COUNTY: FALLS	SHEET NO: 16	
9-07 8-14				

DISCLAIMER: This standard is governed by the "Texas Engineering Practice Act". No warranty of any kind is made by TxDOT for any purpose whatsoever. TxDOT assumes no responsibility for the conversion of this standard to other formats or for incorrect results or damages resulting from its use.

DATE: 3/23/2021 9:44:44 AM  
 FILE: T:\WACMAINT\T-RMC-Contr\accs\BoseF01\ure\_Pvm\Mat\m\FY-2022\FALLS\SCADD\SHEETS\STANDARDS\bc-14.dgn

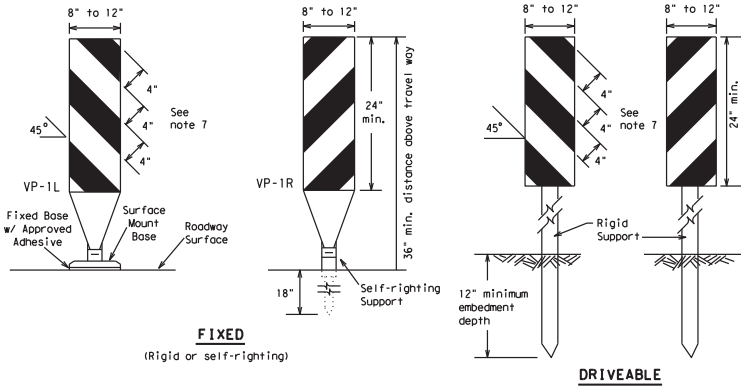

**FIXED**  
(Rigid or self-righting)

**DRIVEABLE**

- Vertical Panels (VP's) are normally used to channelize traffic or divide opposing lanes of traffic.
- VP's may be used in daytime or nighttime situations. They may be used at the edge of shoulder drop-offs and other areas such as lane transitions where positive daytime and nighttime delineation is required. The Engineer/Inspector shall refer to the Roadway Design Manual Appendix B "Treatment of Pavement Drop-offs in Work Zones" for additional guidelines on the use of VP's for drop-offs.
- VP's should be mounted back to back if used at the edge of cuts adjacent to two-way two lane roadways. Stripes are to be reflective orange and reflective white and should always slope downward toward the travel lane.
- VP's used on expressways and freeways or other high speed roadways, may have more than 270 square inches of retroreflective area facing traffic.
- Self-righting supports are available with portable base. See "Compliant Work Zone Traffic Control Devices List" (CWZTCD).
- Sheeting for the VP's shall be retroreflective Type A conforming to Departmental Material Specification DMS-8300, unless noted otherwise.
- Where the height of reflective material on the vertical panel is 36 inches or greater, a panel stripe of 6 inches shall be used.

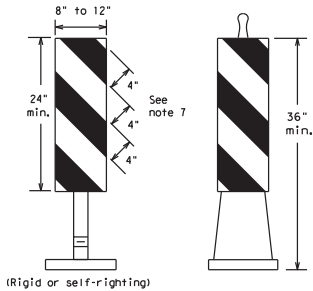

(Rigid or self-righting)

**PORTABLE**

**VERTICAL PANELS (VPs)**

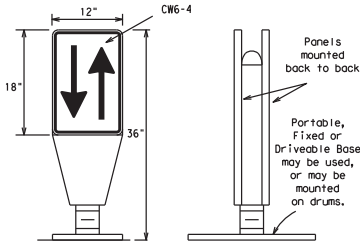

**OPPOSING TRAFFIC LANE DIVIDERS (OTLD)**

- Opposing Traffic Lane Dividers (OTLD) are delineation devices designed to convert a normal one-way roadway section to two-way operation. OTLD's are used on temporary centerlines. The upward and downward arrows on the sign's face indicate the direction of traffic on either side of the divider. The base is secured to the pavement with an adhesive or rubber weight to minimize movement caused by a vehicle impact or wind gust.
- The OTLD may be used in combination with 42" cones or VPS.
- Spacing between the OTLD shall not exceed 500 feet. 42" cones or VPS placed between the OTLD's should not exceed 100 foot spacing.
- The OTLD shall be orange with a black non-reflective legend. Sheeting for the OTLD shall be retroreflective Type B<sub>1</sub> or Type C<sub>1</sub> conforming to Departmental Material Specification DMS-8300, unless noted otherwise. The legend shall meet the requirements of DMS-8300.

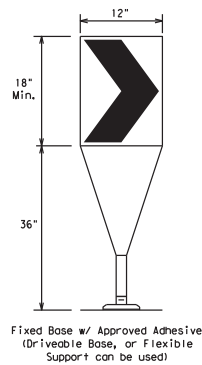

Fixed Base w/ Approved Adhesive (Driveable Base, or Flexible Support can be used)

- The chevron shall be a vertical rectangle with a minimum size of 12 by 18 inches.
- Chevrons are intended to give notice of a sharp change of alignment with the direction of travel and provide additional emphasis and guidance for vehicle operators with regard to changes in horizontal alignment of the roadway.
- Chevrons, when used, shall be erected on the outside of a sharp curve or turn, or on the far side of an intersection. They shall be in line with and at right angles to approaching traffic. Spacing should be such that the motorist always has three in view, until the change in alignment eliminates its need.
- To be effective, the chevron should be visible for at least 500 feet.
- Chevrons shall be orange with a black nonreflective legend. Sheeting for the chevron shall be retroreflective Type B<sub>1</sub> or Type C<sub>1</sub> conforming to Departmental Material Specification DMS-8300, unless noted otherwise. The legend shall meet the requirements of DMS-8300.
- For Long Term Stationary use on tapers or transitions on freeways and divided highways self-righting chevrons may be used to supplement plastic drums but not to replace plastic drums.

**CHEVRONS**

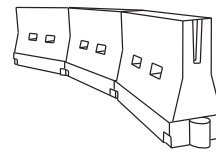

**LONGITUDINAL CHANNELIZING DEVICES (LCD)**

- LCDs are crashworthy, lightweight, deformable devices that are highly visible, have good target value and can be connected together. They are not designed to contain or redirect a vehicle on impact.
- LCDs may be used instead of a line of cones or drums.
- LCDs shall be placed in accordance to application and installation requirements specific to the device, and used only when shown on the CWZTCD list.
- LCDs should not be used to provide positive protection for obstacles, pedestrians or workers.
- LCDs shall be supplemented with retroreflective delineation as required for temporary barriers on BC(7) when placed roughly parallel to the travel lanes.
- LCDs used as barricades placed perpendicular to traffic should have at least one row of reflective sheeting meeting the requirements for barricade rails as shown on BC(10) placed near the top of the LCD along the full length of the device.

**WATER BALLASTED SYSTEMS USED AS BARRIERS**

- Water ballasted systems used as barriers shall not be used solely to channelize road users, but also to protect the work space per the appropriate NCHRP 350 crashworthiness requirements based on roadway speed and barrier application.
- Water ballasted systems used to channelize vehicular traffic shall be supplemented with retroreflective delineation or channelizing devices to improve daytime/nighttime visibility. They may also be supplemented with pavement markings.
- Water ballasted systems used as barriers shall be placed in accordance to application and installation requirements specific to the device, and used only when shown on the CWZTCD list.
- Water ballasted systems used as barriers should not be used for a merging taper except in low speed (less than 45 MPH) urban areas. When used on a taper in a low speed urban area, the taper shall be delineated and the taper length should be designed to optimize road user operations considering the available geometric conditions.
- When water ballasted systems used as barriers have blunt ends exposed to traffic, they should be attenuated as per manufacturer recommendations or flared to a point outside the clear zone.

If used to channelize pedestrians, longitudinal channelizing devices or water ballasted systems must have a continuous detectable bottom for users of long cones and the top of the unit shall not be less than 32 inches in height.

**HOLLOW OR WATER BALLASTED SYSTEMS USED AS LONGITUDINAL CHANNELIZING DEVICES OR BARRIERS**

**GENERAL NOTES**

- Work Zone channelizing devices illustrated on this sheet may be installed in close proximity to traffic and are suitable for use on high or low speed roadways. The Engineer/Inspector shall ensure that spacing and placement is uniform and in accordance with the "Texas Manual on Uniform Traffic Control Devices" (TMUTCD).
- Channelizing devices shown on this sheet may have a driveable, fixed or portable base. The requirement for self-righting channelizing devices must be specified in the General Notes or other plan sheets.
- Channelizing devices on self-righting supports should be used in work zone areas where channelizing devices are frequently impacted by errant vehicles or vehicle related wind gusts making alignment of the channelizing devices difficult to maintain. Locations of these devices shall be detailed elsewhere in the plans. These devices shall conform to the TMUTCD and the "Compliant Work Zone Traffic Control Devices List" (CWZTCD).
- The Contractor shall maintain devices in a clean condition and replace damaged, nonreflective, faded, or broken devices and bases as required by the Engineer/Inspector. The Contractor shall be required to maintain proper device spacing and alignment.
- Portable bases shall be fabricated from virgin and/or recycled rubber. The portable bases shall weigh a minimum of 30 lbs.
- Pavement surfaces shall be prepared in a manner that ensures proper bonding between the adhesives, the fixed mount bases and the pavement surface. Adhesives shall be prepared and applied according to the manufacturer's recommendations.
- The installation and removal of channelizing devices shall not cause detrimental effects to the final pavement surfaces, including pavement surface discoloration or surface integrity. Driveable bases shall not be permitted on final pavement surfaces. The Engineer/Inspector shall approve all application and removal procedures of fixed bases.

Posted Speed %	Formula	Minimum Desirable Taper Lengths **			Suggested Maximum Spacing of Channelizing Devices	
		10' Offset	11' Offset	12' Offset	On a Taper	On a Tangent
30	L = WS / 60	150'	165'	180'	30'	60'
35		205'	225'	245'	35'	70'
40		265'	295'	320'	40'	80'
45	L = WS	450'	495'	540'	45'	90'
50		500'	550'	600'	50'	100'
55		550'	605'	660'	55'	110'
60		600'	660'	720'	60'	120'
65		650'	715'	780'	65'	130'
70		700'	770'	840'	70'	140'
75	750'	825'	900'	75'	150'	
80	800'	880'	960'	80'	160'	

\*\*Taper lengths have been rounded off.  
L=Length of Taper (FT.) W=Width of Offset (FT.)  
S=Posted Speed (MPH)

**SUGGESTED MAXIMUM SPACING OF CHANNELIZING DEVICES AND MINIMUM DESIRABLE TAPER LENGTHS**

SHEET 9 OF 12



**BARRICADE AND CONSTRUCTION CHANNELIZING DEVICES**

**BC (9) - 14**

FILE:	bc-14.dgn	DN:	TxDOT	CK:	TxDOT	DR:	TxDOT	EX:	TxDOT
REVISED:	November 2002	CONT:	SECT	JOB:	HIGHWAY				
9-07	8-14	6379	46	001	SH 320, ETC				
7-13		DIST:	COUNTY	SHEET NO.					
		WACO	FALLS	17					

**TYPE 3 BARRICADES**

1. Refer to the Compliant Work Zone Traffic Control Devices List (CWZTD) for details of the Type 3 Barricades and a list of all materials used in the construction of Type 3 Barricades.
2. Type 3 Barricades shall be used at each end of construction projects closed to all traffic.
3. Barricades extending across a roadway should have stripes that slope downward in the direction toward which traffic must turn in detouring. When both right and left turns are provided, the chevron striping may slope downward in both directions from the center of the barricade. Where no turns are provided at a closed road striping should slope downward in both directions toward the center of roadway.
4. Striping of rails, for the right side of the roadway, should slope downward to the left. For the left side of the roadway, striping should slope downward to the right.
5. Identification markings may be shown only on the back of the barricade rails. The maximum height of letters and/or company logos used for identification shall be 1".
6. Barricades shall not be placed parallel to traffic unless an adequate clear zone is provided.
7. Warning lights shall NOT be installed on barricades.
8. Where barricades require the use of weights to keep from turning over, the use of sandbags with dry, cohesionless sand is recommended. The sandbags will be tied shut to keep the sand from spilling and to maintain a constant weight. Sand bags shall not be stacked in a manner that covers any portion of a barricade rails reflective sheeting. Rock, concrete, iron, steel or other solid objects will NOT be permitted. Sandbags should weigh a minimum of 35 lbs and a maximum of 50 lbs. Sandbags shall be made of a durable material that tears upon vehicular impact. Rubber (such as fire inner tubes) shall not be used for sandbags. Sandbags shall only be placed along or upon the base supports of the device and shall not be suspended above ground level or hung with rope, wire, chains or other fasteners.
9. Sheeting for barricades shall be retroreflective Type A conforming to Departmental Material Specification DMS-8300 unless otherwise noted.

Barricades shall NOT be used as a sign support.



**TYPICAL STRIPING DETAIL FOR BARRICADE RAIL**

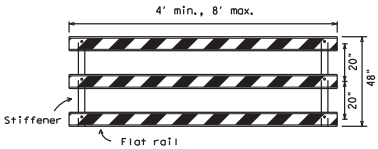

**TYPICAL PANEL DETAIL FOR SKID OR POST TYPE BARRICADES**

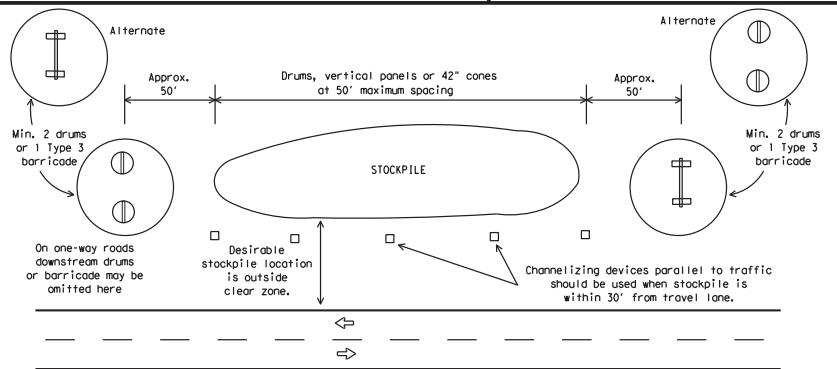

**TRAFFIC CONTROL FOR MATERIAL STOCKPILES**

Each roadway of a divided highway shall be barricaded in the same manner.

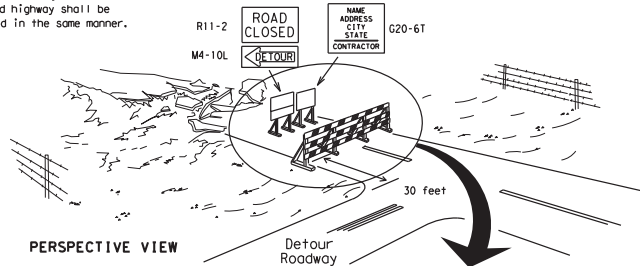

PERSPECTIVE VIEW

The three rails on Type 3 barricades shall be reflectorized orange and reflective white stripes on one side facing one-way traffic and both sides for two-way traffic. Barricade striping should slant downward in the direction of detour.

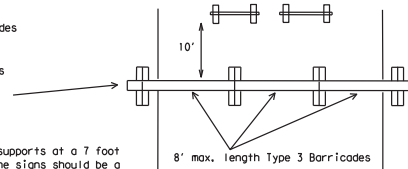

PLAN VIEW

1. Signs should be mounted on independent supports at a 7 foot mounting height in center of roadway. The signs should be a minimum of 10 feet behind Type 3 Barricades.
2. Advance signing shall be as specified elsewhere in the plans.

**TYPE 3 BARRICADE (POST AND SKID) TYPICAL APPLICATION**

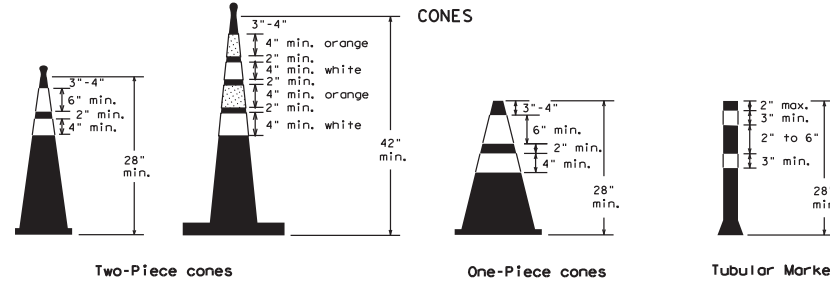

28" Cones shall have a minimum weight of 9 1/2 lbs.  
42" 2-piece cones shall have a minimum weight of 30 lbs. including base.

1. Traffic cones and tubular markers shall be predominantly orange, and meet the height and weight requirements shown above.
2. One-piece cones have the body and base of the cone molded in one consolidated unit. Two-piece cones have a cone shaped body and a separate rubber base, or ballast, that is added to keep the device upright and in place.
3. Two-piece cones may have a handle or loop extending up to 8" above the minimum height shown, in order to aid in retrieving the device.
4. Cones or tubular markers used at night shall have white or white and orange reflective bands as shown above. The reflective bands shall have a smooth, sealed outer surface and meet the requirements of Departmental Material Specification DMS-8300 Type A.
5. 28" cones and tubular markers are generally suitable for short duration and short-term stationary work as defined on BC(14). These should not be used for intermediate-term or long-term stationary work unless personnel is on-site to maintain them in their proper upright position.
6. 42" two-piece cones, vertical panels or drums are suitable for all work zone durations.
7. Cones or tubular markers used on each project should be of the same size and shape.

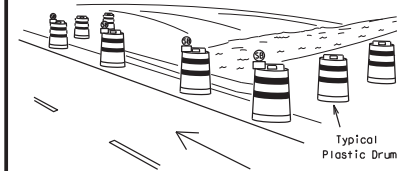

PERSPECTIVE VIEW

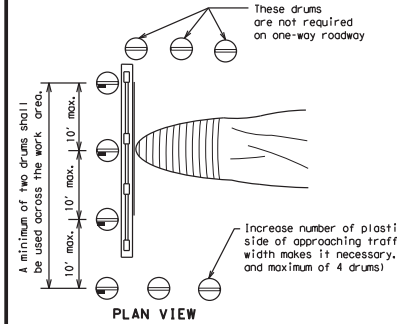

PLAN VIEW

1. Where positive redirection capability is provided, drums may be omitted.
2. Plastic construction fencing may be used with drums for safety as required in the plans.
3. Vertical Panels on flexible support may be substituted for drums when the shoulder width is less than 4 feet.
4. When the shoulder width is greater than 12 feet, steady-burn lights may be omitted if drums are used.
5. Drums must extend the length of the culvert widening.

LEGEND	
	Plastic drum
	Plastic drum with steady burn light or yellow warning reflector
	Steady burn warning light or yellow warning reflector

**CULVERT WIDENING OR OTHER ISOLATED WORK WITHIN THE PROJECT LIMITS**

THIS DEVICE SHALL NOT BE USED ON PROJECTS LET AFTER MARCH 2014.

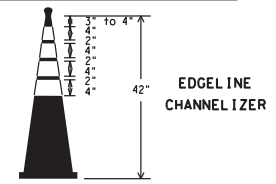

EDGELINE CHANNELIZER

1. This device is intended only for use in place of a vertical panel to channelize traffic by indicating the edge of the travel lane. It is not intended to be used in transitions or tapers.
2. This device shall not be used to separate lanes of traffic (topposing or otherwise) or warn of objects.
3. This device is based on a 42 inch, two-piece cone with an alternate striping pattern: four 4 inch retroreflective bands, with an approximate 2 inch gap between bands. The color of the band should correspond to the color of the edgeline (yellow for left edgeline, white for right edgeline) for which the device is substituted or for which it supplements. The reflectorized bands shall be retroreflective Type A conforming to Departmental Material Specification DMS-8300, unless otherwise noted.
4. The base must weigh a minimum of 30 lbs.

**BARRICADE AND CONSTRUCTION CHANNELIZING DEVICES**

**BC (10) - 14**

FILE: dc-14.dgn	DWG: TXDOT	CHK: TXDOT	APP: TXDOT	CHK: TXDOT
REV: November 2002	CONT: 6379	SECT: 46	JOB: 001	SH: 320, ETC
REV: 9-07	DIST: 8-14	COUNTY: WACO	COUNTY: FALLS	SHEET NO: 18
REV: 7-13				

DISCLAIMER: This standard is governed by the "Texas Engineering Practice Act". No warranty of any kind is made by TxDOT for any purpose whatsoever. TxDOT assumes no responsibility for the conversion of this standard to other formats or for incorrect results or damages resulting from its use.

DATE: 3/23/2021 9:44:45 AM  
FILE: T:\WACMINT\T3\BMC\_Contractors\Base\Fall-2022\FALLS\CAD\STD\STANDARDS\bc-14.dgn

DISCLAIMER: This standard is governed by the "Texas Engineering Practice Act". No warranty of any kind is made by TxDOT for any purpose whatsoever. TxDOT assumes no responsibility for the conversion of this standard to other formats or for incorrect results or damages resulting from its use.

DATE: 3/23/2021 9:44:46 AM  
 FILE: T:\MACMAINT\1\BMC\_Contractors\Bosef01\lure\_Pvm\Main\FY-2022\FALL\SCADD\SHEETS\STANDARDS\bc-14.dgn

## WORK ZONE PAVEMENT MARKINGS

### GENERAL

- The Contractor shall be responsible for maintaining work zone and existing pavement markings, in accordance with the standard specifications and special provisions, on all roadways open to traffic within the CSJ limits unless otherwise stated in the plans.
- Color, patterns and dimensions shall be in conformance with the "Texas Manual on Uniform Traffic Control Devices" (TMUTCD).
- Additional supplemental pavement marking details may be found in the plans or specifications.
- Pavement markings shall be installed in accordance with the TMUTCD and as shown on the plans.
- When short term markings are required on the plans, short term markings shall conform with the TMUTCD, the plans and details as shown on the Standard Plan Sheet WZ(S1PM).
- When standard pavement markings are not in place and the roadway is opened to traffic, DO NOT PASS signs shall be erected to mark the beginning of the sections where passing is prohibited and PASS WITH CARE signs at the beginning of sections where passing is permitted.
- All work zone pavement markings shall be installed in accordance with Item 662, "Work Zone Pavement Markings."

### RAISED PAVEMENT MARKERS

- Raised pavement markers are to be placed according to the patterns on BC(12).
- All raised pavement markers used for work zone markings shall meet the requirements of Item 672, "RAISED PAVEMENT MARKERS" and Departmental Material Specification DMS-4200 or DMS-4300.

### PREFABRICATED PAVEMENT MARKINGS

- Removable prefabricated pavement markings shall meet the requirements of DMS-8241.
- Non-removable prefabricated pavement markings (foil back) shall meet the requirements of DMS-8240.

### MAINTAINING WORK ZONE PAVEMENT MARKINGS

- The Contractor will be responsible for maintaining work zone pavement markings within the work limits.
- Work zone pavement markings shall be inspected in accordance with the frequency and reporting requirements of work zone traffic control device inspections as required by Form 599.
- The markings should provide a visible reference for a minimum distance of 300 feet during normal daylight hours and 160 feet when illuminated by automobile low-beam headlights at night, unless sight distance is restricted by roadway geometrics.
- Markings failing to meet this criteria within the first 30 days after placement shall be replaced at the expense of the Contractor as per Specification Item 662.

### REMOVAL OF PAVEMENT MARKINGS

- Pavement markings that are no longer applicable, could create confusion or direct a motorist toward or into the closed portion of the roadway shall be removed or obliterated before the roadway is opened to traffic.
- The above shall not apply to detours in place for less than three days, where flaggers and/or sufficient channelizing devices are used in lieu of markings to outline the detour route.
- Pavement markings shall be removed to the fullest extent possible, so as not to leave a discernable marking. This shall be by any method approved by TxDOT Specification Item 677 for "Eliminating Existing Pavement Markings and Markers".
- The removal of pavement markings may require resurfacing or seal coating portions of the roadway as described in Item 677.
- Subject to the approval of the Engineer, any method that proves to be successful on a particular type pavement may be used.
- Blast cleaning may be used but will not be required unless specifically shown in the plans.
- Over-painting of the markings SHALL NOT BE permitted.
- Removal of raised pavement markers shall be as directed by the Engineer.
- Removal of existing pavement markings and markers will be paid for directly in accordance with Item 677, "ELIMINATING EXISTING PAVEMENT MARKINGS AND MARKERS," unless otherwise stated in the plans.
- Black-out marking tape may be used to cover conflicting existing markings for periods less than two weeks when approved by the Engineer.

## Temporary Flexible-Reflective Roadway Marker Tabs

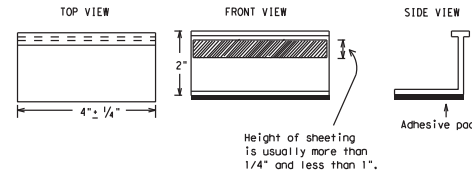

**STAPLES OR NAILS SHALL NOT BE USED TO SECURE TEMPORARY FLEXIBLE-REFLECTIVE ROADWAY MARKER TABS TO THE PAVEMENT SURFACE**

- Temporary flexible-reflective roadway marker tabs used as guidemarks shall meet the requirements of DMS-8242.
- Tabs detailed on this sheet are to be inspected and accepted by the Engineer or designated representative. Sampling and testing is not normally required, however at the option of the Engineer, either "A" or "B" below may be imposed to assure quality before placement on the roadway.
  - Select five (5) or more tabs at random from each lot or shipment and submit to the Construction Division, Materials and Pavement Section to determine specification compliance.
  - Select five (5) tabs and perform the following test. Affix five (5) tabs at 24 inch intervals on an asphaltic pavement in a straight line. Using a medium size passenger vehicle or pickup, run over the markers with the front and rear tires at a speed of 35 to 40 miles per hour, four (4) times in each direction. No more than one (1) out of the five (5) reflective surfaces shall be lost or displaced as a result of this test.
- Small design variances may be noted between tab manufacturers.
- See Standard Sheet WZ(S1PM) for tab placement on new pavements. See Standard Sheet TCP(7-1) for tab placement on seal coat work.

### RAISED PAVEMENT MARKERS USED AS GUIDEMARKS

- Raised pavement markers used as guidemarks shall be from the approved product list, and meet the requirements of DMS-4200.
- All temporary construction raised pavement markers provided on a project shall be of the same manufacturer.
- Adhesive for guidemarks shall be bituminous material hot applied or butyl rubber pad for all surfaces, or thermoplastic for concrete surfaces.

Guidemarks shall be designated as:

- YELLOW - (two amber reflective surfaces with yellow body).
- WHITE - (one silver reflective surface with white body).

DEPARTMENTAL MATERIAL SPECIFICATIONS	
PAVEMENT MARKERS (REFLECTORIZED)	DMS-4200
TRAFFIC BUTTONS	DMS-4300
EPOXY AND ADHESIVES	DMS-6100
BITUMINOUS ADHESIVE FOR PAVEMENT MARKERS	DMS-6130
PERMANENT PREFABRICATED PAVEMENT MARKINGS	DMS-8240
TEMPORARY REMOVABLE, PREFABRICATED PAVEMENT MARKINGS	DMS-8241
TEMPORARY FLEXIBLE, REFLECTIVE ROADWAY MARKER TABS	DMS-8242

A list of prequalified reflective raised pavement markers, non-reflective traffic buttons, roadway marker tabs and other pavement markings can be found at the Material Producer List web address shown on BC(1).

SHEET 11 OF 12



## BARRICADE AND CONSTRUCTION PAVEMENT MARKINGS

**BC(11)-14**

FILE: bc-14.dgn	DN: TxDOT	CR: TxDOT	DN: TxDOT	CR: TxDOT
© TxDOT February 1998	CONT	SECT	JOB	HIGHWAY
2-98 9-07 REVISIONS	6379	46	001	SH 320, ETC
1-02 7-13	DIST	COUNTY	SHEET NO.	
11-02 8-14	WACO	FALLS	19	

105





DISCLAIMER: This standard is governed by the "Texas Engineering Practice Act". No warranty of any kind is made by TxDOT for any purpose whatsoever. TxDOT assumes no responsibility for the conversion of this standard to other formats or for incorrect results or damages resulting from its use.

DATE: 3/23/2021  
 FILE: T:\M\MAINT\...RMC\_Contract\Bases\of\Ture\_Pvm\Main\FY-2022\FALLS\CADD\SHEETS\STANDARDS\tcp1-1-18.dgn

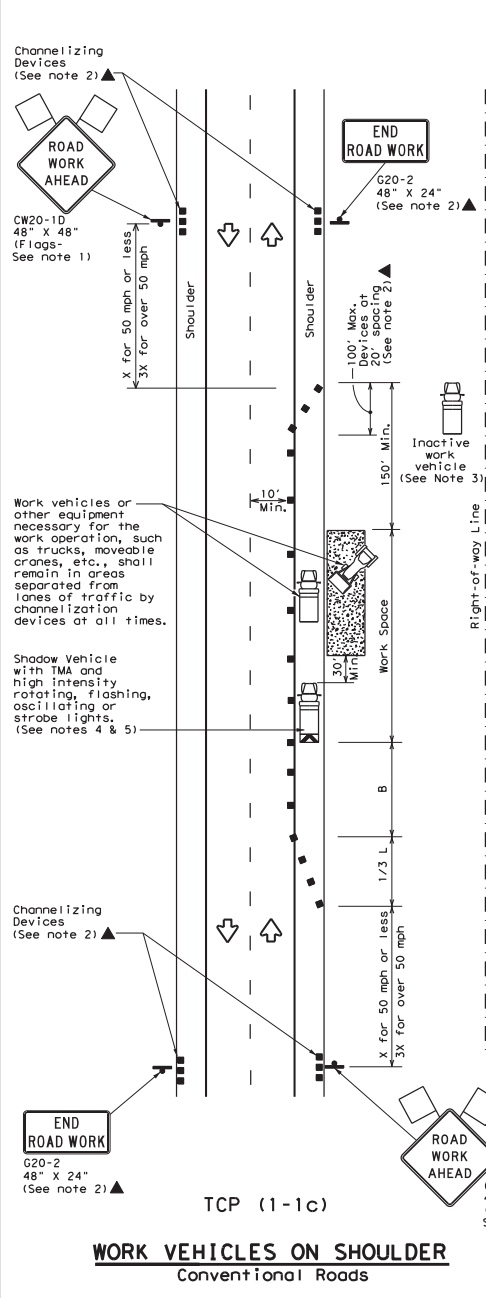
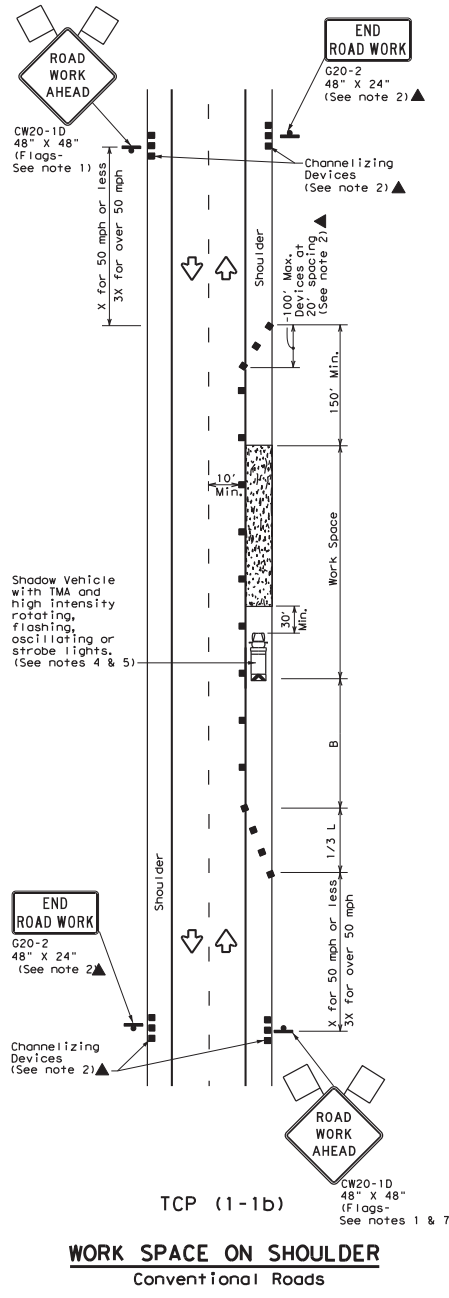
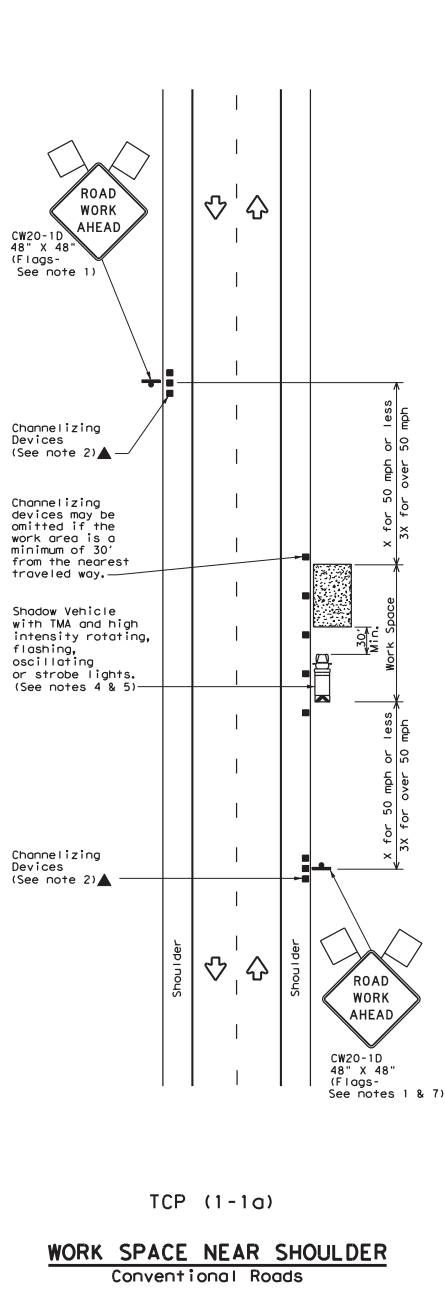

LEGEND			
	Type 3 Barricade		Channelizing Devices
	Heavy Work Vehicle		Truck Mounted Attenuator (TMA)
	Trailer Mounted Flashing Arrow Board		Portable Changeable Message Sign (PCMS)
	Sign		Traffic Flow
	Flag		Flagger

Posted Speed %	Formula	Minimum Desirable Taper Lengths * %			Suggested Maximum Spacing of Channelizing Devices		Minimum Sign Spacing "A"	Suggested Longitudinal Buffer Space "B"
		10' Offset	11' Offset	12' Offset	On a Taper	On a Tangent		
30	$L = \frac{WS^2}{60}$	150'	165'	180'	30'	60'	120'	90'
35		205'	225'	245'	35'	70'	160'	120'
40		265'	295'	320'	40'	80'	240'	155'
45		450'	495'	540'	45'	90'	320'	195'
50	$L = WS$	500'	550'	600'	50'	100'	400'	240'
55		550'	605'	660'	55'	110'	500'	295'
60		600'	660'	720'	60'	120'	600'	350'
65		650'	715'	780'	65'	130'	700'	410'
70		700'	770'	840'	70'	140'	800'	475'
75		750'	825'	900'	75'	150'	900'	540'

\* Conventional Roads Only  
 \*\* Taper lengths have been rounded off.  
 L=Length of Taper (FT) W=Width of Offset (FT) S=Posted Speed (MPH)

TYPICAL USAGE				
MOBILE	SHORT DURATION	SHORT TERM STATIONARY	INTERMEDIATE TERM STATIONARY	LONG TERM STATIONARY
	✓	✓		

- GENERAL NOTES**
- Flags attached to signs where shown are REQUIRED.
  - All traffic control devices illustrated are REQUIRED, except those denoted with the triangle symbol may be omitted when stated elsewhere in the plans, or for routine maintenance work, when approved by the Engineer.
  - Inactive work vehicles or other equipment should be parked near the right-of-way line and not parked on the paved shoulder.
  - A Shadow Vehicle with a TMA should be used anytime it can be positioned 30 to 100 feet in advance of the area of crew exposure without adversely affecting the performance or quality of the work. If workers are no longer present but road or work conditions require the traffic control to remain in place, Type 3 Barricades or other channelizing devices may be substituted for the Shadow Vehicle and TMA.
  - Additional Shadow Vehicles with TMAs may be positioned off the paved surface, next to those shown in order to protect wider work spaces.
  - See TCP(5-1) for shoulder work on divided highways, expressways and freeways.
  - CW21-5 "SHOULDER WORK" signs may be used in place of CW20-1D "ROAD WORK AHEAD" signs for shoulder work on conventional roadways.

**Texas Department of Transportation**  
 Traffic Operations Division

**TRAFFIC CONTROL PLAN**  
**CONVENTIONAL ROAD**  
**SHOULDER WORK**

**TCP (1-1) - 18**

FILE: tcp1-1-18.dgn	DATE: December 1985	CONTRACT NO: 6379	SECTION: 46	JOB NO: 001	SH 320, ETC
REVISIONS:					
2-94 4-98					
8-95 2-12					
1-97 2-18					
		DIST: WACO	COUNTY: FALLS	SHEET NO: 21	





DISCLAIMER: This standard is governed by the "Texas Engineering Practice Act". No warranty of any kind is made by TxDOT for any purpose whatsoever. TxDOT assumes no responsibility for the conversion of this standard to other formats or for incorrect results or damages resulting from its use.

DATE: 3/23/2021  
 FILE: T:\MACMAINT\1-RMC-Contract&Base\01-Lure-Pvm\Main\FY-2022\FALLS\CADD\SHEETS\STANDARDS\tcp1-4-18.dgn

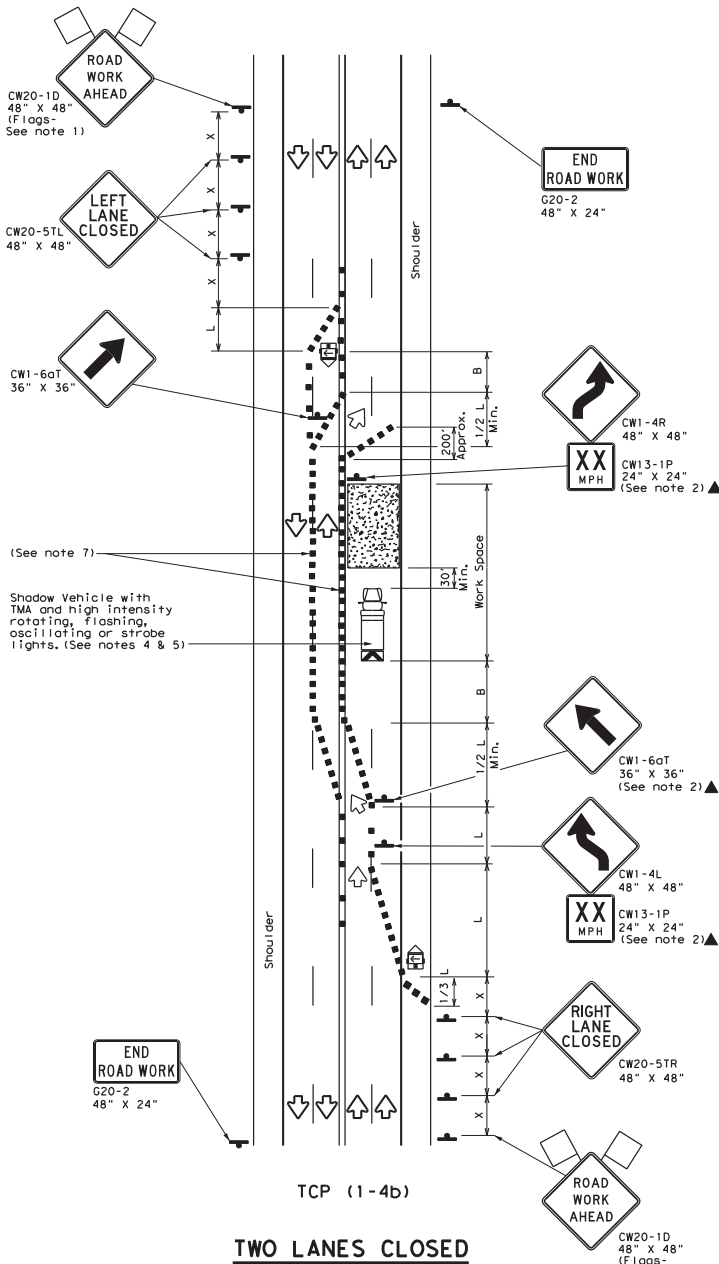
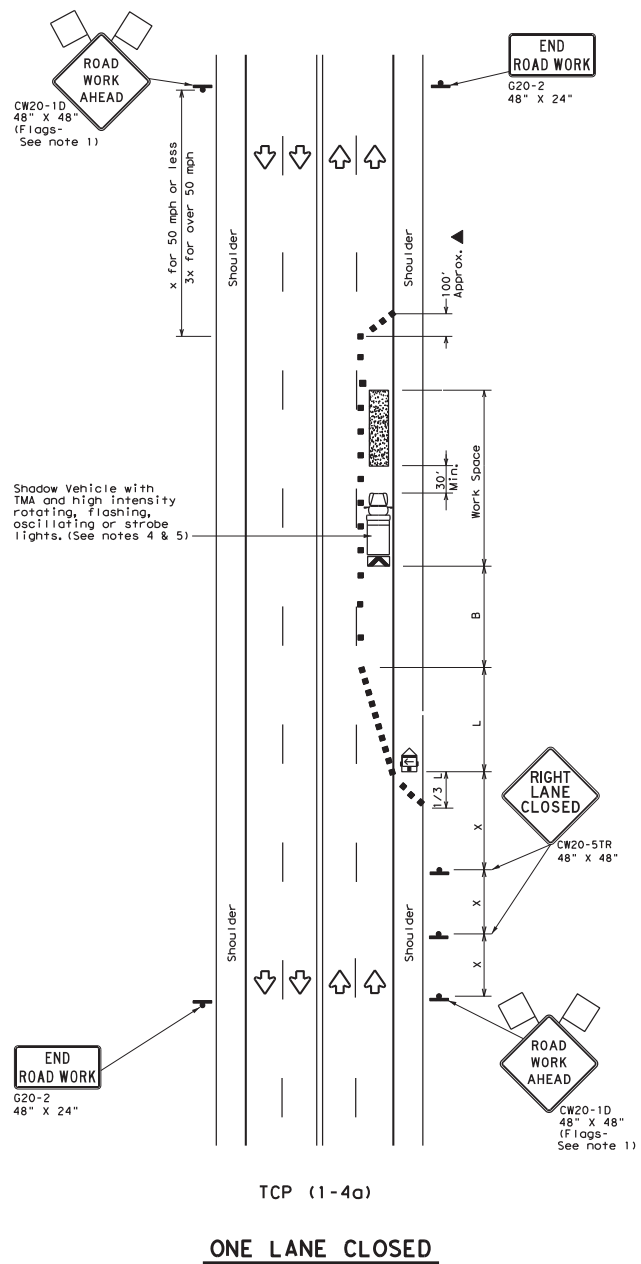

LEGEND			
	Type 3 Barricade		Channelizing Devices
	Heavy Work Vehicle		Truck Mounted Attenuator (TMA)
	Trailer Mounted Flashing Arrow Board		Portable Changeable Message Sign (PCMS)
	Sign		Traffic Flow
	Flag		Flagger

Posted Speed *	Formula	Minimum Desirable Taper Lengths *x			Suggested Maximum Spacing of Channelizing Devices		Minimum Sign Spacing "x"	Suggested Longitudinal Buffer Space "B"
		10' Offset	11' Offset	12' Offset	On a Taper	On a Tangent		
30	L = WS <sup>2</sup> / 60	150'	165'	180'	30'	60'	120'	90'
35		205'	225'	245'	35'	70'	160'	120'
40		265'	295'	320'	40'	80'	240'	155'
45	L = WS	450'	495'	540'	45'	90'	320'	195'
50		500'	550'	600'	50'	100'	400'	240'
55		550'	605'	660'	55'	110'	500'	295'
60		600'	660'	720'	60'	120'	600'	350'
65		650'	715'	780'	65'	130'	700'	410'
70	700'	770'	840'	70'	140'	800'	475'	
75	750'	825'	900'	75'	150'	900'	540'	

\* Conventional Roads Only  
 \*\* Taper lengths have been rounded off.  
 L=Length of Taper(FT) W=Width of Offset(FT) S=Posted Speed(MPH)

TYPICAL USAGE				
MOBILE	SHORT DURATION	SHORT TERM STATIONARY	INTERMEDIATE TERM STATIONARY	LONG TERM STATIONARY
	✓	✓		

- GENERAL NOTES**
- Flags attached to signs where shown are REQUIRED.
  - All traffic control devices illustrated are REQUIRED, except those denoted with the triangle symbol may be omitted when stated elsewhere in the plans, or for routine maintenance work, when approved by the Engineer.
  - The CW20-1D "ROAD WORK AHEAD" sign may be repeated if the visibility of the work zone is less than 1500 feet.
  - A Shadow Vehicle with a TMA should be used anytime it can be positioned 30 to 100 feet in advance of the area of crew exposure without adversely affecting the performance or quality of the work. If workers are no longer present but road or work conditions require the traffic control to remain in place, Type 3 Barricades or other channelizing devices may be substituted for the Shadow Vehicle and TMA.
  - Additional Shadow Vehicles with TMAs may be positioned off the paved surface, next to those shown in order to protect wider work spaces.
- TCP (1-4a)**
- If this TCP is used for a left lane closure, CW20-5TL "LEFT LANE CLOSED" signs shall be used and channelizing devices shall be placed on the centerline where needed to protect the work space from opposing traffic with the arrow panel placed in the closed lane near the end of the merging taper.
- TCP (1-4b)**
- Where traffic is directed over a yellow centerline, channelizing devices which separate two-way traffic should be spaced on tapers at 20' or 15' if posted speeds are 35 mph or slower, and for tangent sections, at 1/2S where S is the speed in mph. This tighter device spacing is intended for the areas of conflicting markings, not the entire work zone.

Traffic Operations Division Standard

## TRAFFIC CONTROL PLAN LANE CLOSURES ON MULTILANE CONVENTIONAL ROADS

### TCP (1-4) - 18

FILE: tcp1-4-18.dgn	DATE: December 1985	CONTRACT: 6379	SECTION: 46	JOB: 001	SH: 320, ETC
© TxDOT	REVISIONS:	DIST: WACO	COUNTY: FALLS	SHEET NO. 24	

DISCLAIMER: This standard is governed by the "Texas Engineering Practice Act". No warranty of any kind is made by TxDOT for any purpose whatsoever. TxDOT assumes no responsibility for the conversion of this standard to other formats or for incorrect results or damages resulting from its use.

DATE: 3/23/2021  
 FILE: T:\WACMAINT\1-RMC\_Contract\8-Base\011ure\_Pvm\Main\FY-2022\FALLS\CADD\SHEETS\STANDARDS\tcp1-5-18.dgn

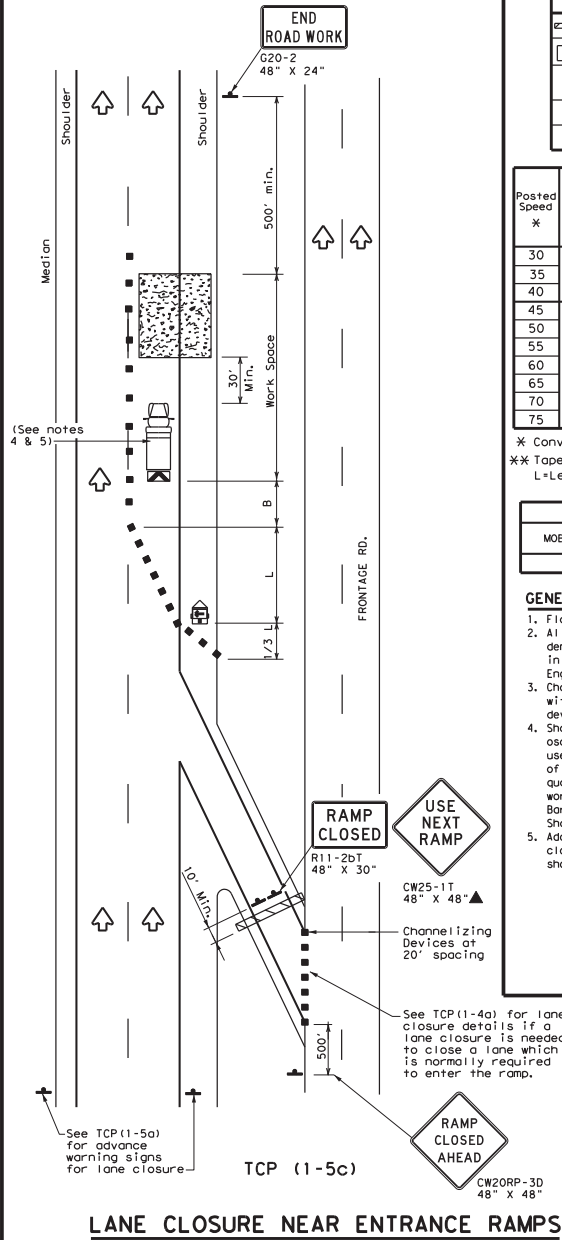
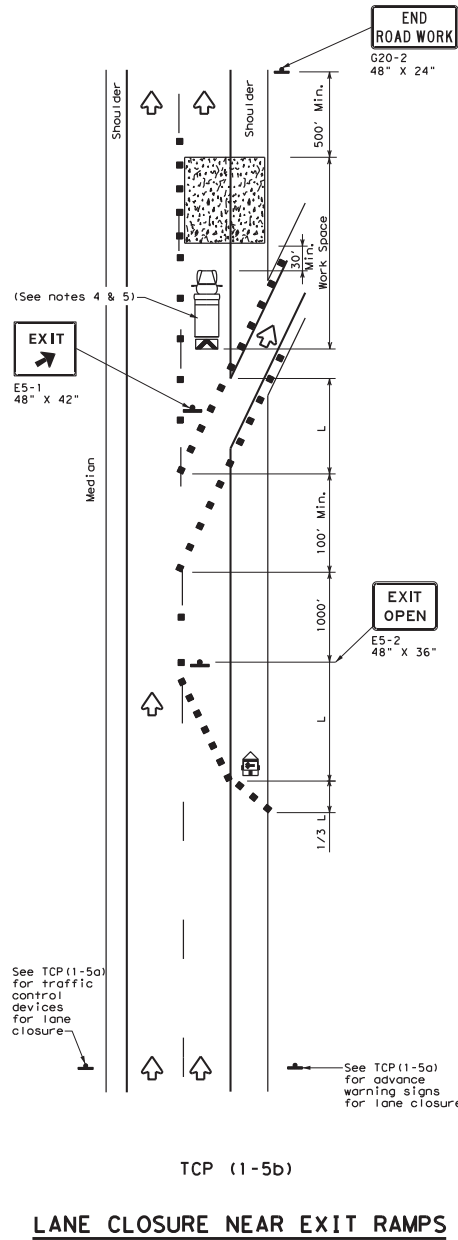
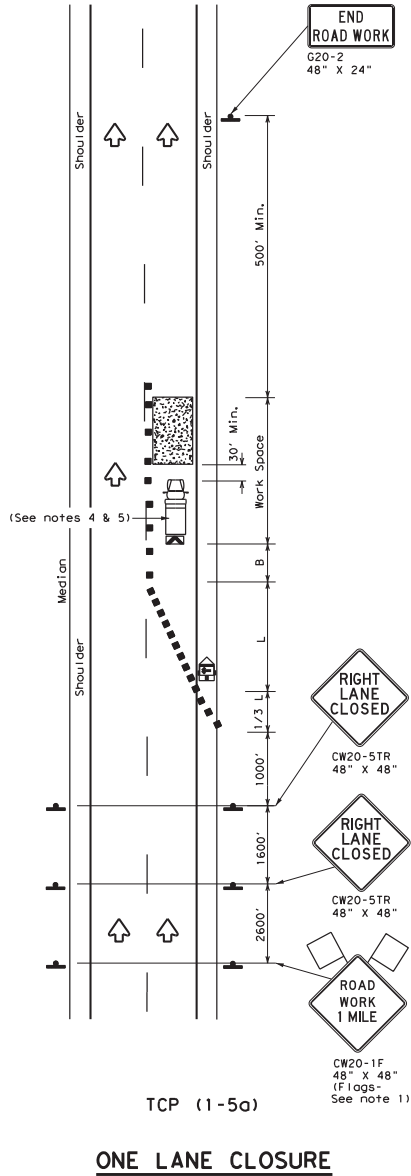

LEGEND			
	Type 3 Barricade		Channelizing Devices
	Heavy Work Vehicle		Truck Mounted Attenuator (TMA)
	Trailer Mounted Flashing Arrow Board		Portable Changeable Message Sign (PCMS)
	Sign		Traffic Flow
	Flag		Flagger

Posted Speed *	Formula	Minimum Desirable Taper Lengths * %			Suggested Maximum Spacing of Channelizing Devices		Minimum Sign Spacing "x" Distance	Suggested Longitudinal Buffer Space "B"
		10' Offset	11' Offset	12' Offset	On a Taper	On a Tangent		
30	L = WS <sup>2</sup> / 60	150'	165'	180'	30'	60'	120'	90'
35		205'	225'	245'	35'	70'	160'	120'
40		265'	295'	320'	40'	80'	240'	155'
45	L = WS	450'	495'	540'	45'	90'	320'	195'
50		500'	550'	600'	50'	100'	400'	240'
55		550'	605'	660'	55'	110'	500'	295'
60		600'	660'	720'	60'	120'	600'	350'
65		650'	715'	780'	65'	130'	700'	410'
70		700'	770'	840'	70'	140'	800'	475'
75		750'	825'	900'	75'	150'	900'	540'

\* Conventional Roads Only  
 \*\* Taper lengths have been rounded off.  
 L=Length of Taper (FT) W=Width of Offset (FT) S=Posted Speed (MPH)

TYPICAL USAGE				
MOBILE	SHORT DURATION	SHORT TERM STATIONARY	INTERMEDIATE TERM STATIONARY	LONG TERM STATIONARY
		✓		

- GENERAL NOTES**
- Flags attached to signs where shown, are REQUIRED.
  - All traffic control devices illustrated are REQUIRED, except those denoted with the triangle symbol may be omitted when stated elsewhere in the plans, or for routine maintenance work, when approved by the Engineer.
  - Channelizing devices used to close lanes may be supplemented with the Chevron Alignment Sign placed on every other channelizing device. Chevrons may be attached to plastic drums as per BC Standards.
  - Shadow Vehicle with TMA and high intensity rotating, flashing, oscillating or strobe lights. A Shadow Vehicle with a TMA should be used anytime it can be positioned 30 to 100 feet in advance of the area of crew exposure without adversely affecting the performance or quality of the work. If workers are no longer present but road or work conditions require the traffic control to remain in place, Type 3 Barricades or other channelizing devices may be substituted for the Shadow Vehicle and TMA.
  - Additional Shadow Vehicles with TMAs may be positioned in each closed lane, on the shoulder or off the paved surface, next to those shown in order to protect a wider work space.

Texas Department of Transportation  
 Traffic Operations Division Standard

**TRAFFIC CONTROL PLAN  
 LANE CLOSURES FOR  
 DIVIDED HIGHWAYS**

**TCP (1-5) - 18**

FILE: tcp1-5-18.dgn	DATE: February 2012	CONTRACT: 6379	SECTION: 46	JOB: 001	HIGHWAY: SH 320, ETC
2-18	REVISIONS	DIST: WACO	COUNTY: FALLS	SHEET NO.: 25	

DISCLAIMER: This standard is governed by the "Texas Engineering Practice Act". No warranty of any kind is made by TxDOT for any purpose whatsoever. TxDOT assumes no responsibility for the conversion of this standard to other formats or for incorrect results or damages resulting from its use.

DATE: 3/23/2021  
 FILE: T:\WACMAINT\1-RMC-Contract\8.8.Base\01\ure\_Pvt\Main\1-19-2022\FALLS\CADD\SHEETS\STANDARDS\tcp1-6-18.dgn

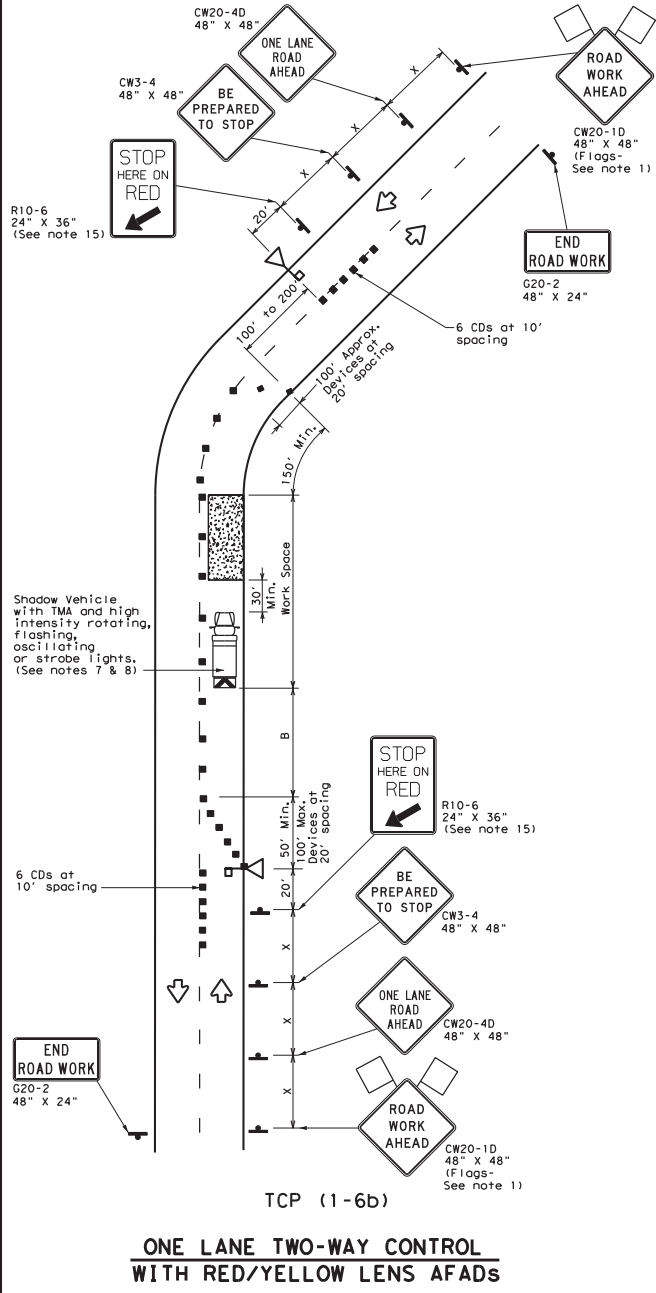
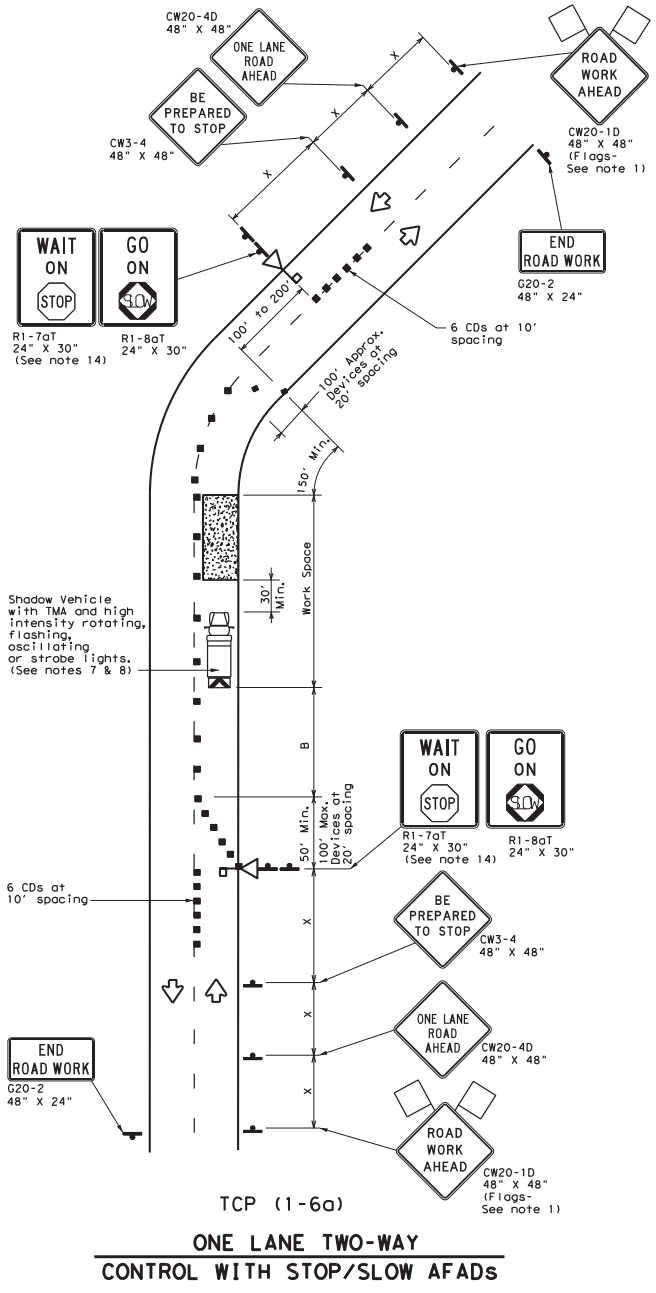

**LEGEND**

	Type 3 Barricade		Channelizing Devices (CDs)
	Heavy Work Vehicle		Truck Mounted Attenuator (TMA)
	Automated Flagger Assistance Device (AFAD)		Portable Changeable Message Sign (PCMS)
	Sign		Traffic Flow
	Flag		Flagger

Posted Speed *	Formula	Minimum Desirable Taper Lengths **			Suggested Maximum Spacing of Channelizing Devices		Minimum Sign Spacing "X" Distance	Suggested Longitudinal Buffer Space "B"	Stopping Sight Distance
		10' Offset	11' Offset	12' Offset	On a Taper	On a Tangent			
30	$L = \frac{W \cdot S^2}{60}$	150'	165'	180'	30'	60'	120'	90'	200'
35		205'	225'	245'	35'	70'	160'	120'	250'
40		265'	295'	320'	40'	80'	240'	155'	305'
45	L + WS	450'	495'	540'	45'	90'	320'	195'	360'
50		500'	550'	600'	50'	100'	400'	240'	425'
55		550'	605'	660'	55'	110'	500'	295'	495'
60		600'	660'	720'	60'	120'	600'	350'	570'
65		650'	715'	780'	65'	130'	700'	410'	645'
70	700'	770'	840'	70'	140'	800'	475'	730'	
75	750'	825'	900'	75'	150'	900'	540'	820'	

\* Conventional Roads Only  
 \*\* Taper lengths have been rounded off.  
 L=Length of Taper (FT) W=Width of Offset (FT) S=Posted Speed (MPH)

**TYPICAL USAGE**

MOBILE	SHORT DURATION	SHORT TERM STATIONARY	INTERMEDIATE TERM STATIONARY	LONG TERM STATIONARY
	✓	✓		

**GENERAL NOTES**

- Flags attached to signs where shown are REQUIRED.
- AFADs shall only be used in situations where there is one lane of approaching traffic in the direction to be controlled.
- Adequate stopping sight distance must be provided to each AFAD location for approaching traffic. (See table above).
- Each AFAD shall be operated by a qualified/certified flagger. Flaggers operating AFADs shall not leave them unattended while they are in use.
- One flagger may operate two AFADs only when the flagger has an unobstructed view of both AFADs and of the approaching traffic in both directions.
- When pilot cars are used, a flagger controlling traffic shall be located on each approach. AFADs shall not be operated by the pilot car operator.
- All AFADs shall be equipped with gate arms with an orange or fluorescent red-orange flag attached to the end of the gate arm. The flag shall be a minimum of 16" square.
- A Shadow Vehicle with a TMA should be used anytime it can be positioned 30 to 100 feet in advance of the area of crew exposure without adversely affecting the performance or quality of the work. If workers are no longer present but road or work conditions require the traffic control to remain in place, Type 3 Barricades or other channelizing devices may be substituted for the Shadow Vehicle and TMA.
- Additional Shadow Vehicles with TMAs may be positioned off the paved surface, next to those shown in order to protect wider work spaces.
- Flaggers should use two-way radios or other methods of communication to control traffic.
- Length of work space should be based on the ability of flaggers to communicate.
- If the work space is located near a horizontal or vertical curve, the buffer distances should be increased in order to maintain stopping sight distance to the AFAD.
- Channelizing devices on the center line may be omitted when a pilot car is leading traffic and approved by the Engineer.
- The R1-7aT "WAIT ON STOP" sign and the R1-8aT "GO ON SLOW" sign shall be installed at the AFAD location on separate supports or they may be fabricated as one 48" x 30" sign. They shall not obscure the face of the STOP/SLOW AFAD.
- The R10-6 "STOP HERE ON RED" arrow sign shall be offset so as not to obscure the lenses of the AFAD.

**Texas Department of Transportation**  
 Traffic Operations Division Standard

**TRAFFIC CONTROL PLAN**  
**AUTOMATED FLAGGER ASSISTANCE DEVICES (AFADs)**  
**TCP (1-6) - 18**

FILE:	tcp1-6-18.dgn	DATE:	02/16/2012	BY:	001	JOB:	SH 320, ETC
REVISIONS:	February 2012	CONT:	46	SECT:	001	COUNTY:	FALLS
2-18		DIST:		WACO:		SHEET NO.:	26

DISCLAIMER: This standard is governed by the "Texas Engineering Practice Act". No warranty of any kind is made by TxDOT for any purpose whatsoever. TxDOT assumes no responsibility for the conversion of this standard to other formats or for incorrect results or damages resulting from its use.

DATE: 3/23/2021  
 FILE: T:\MACMAINT\1-RMC-Contract\8-Base\01-Lure-Pvm\Main\FY-2022\FALLS\CADD\SHEETS\STANDARDS\tcp2-1-18.dgn

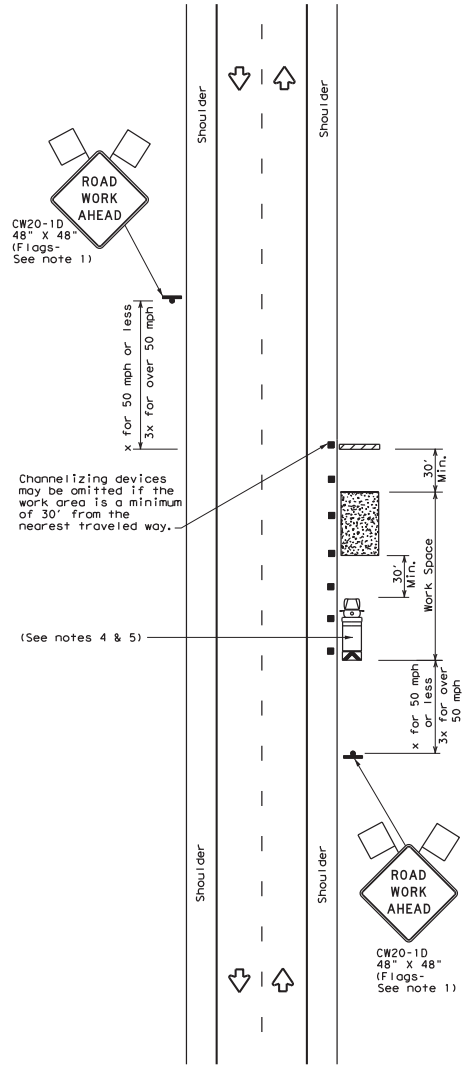

TCP (2-1a)

**WORK SPACE NEAR SHOULDER**  
 Conventional Roads

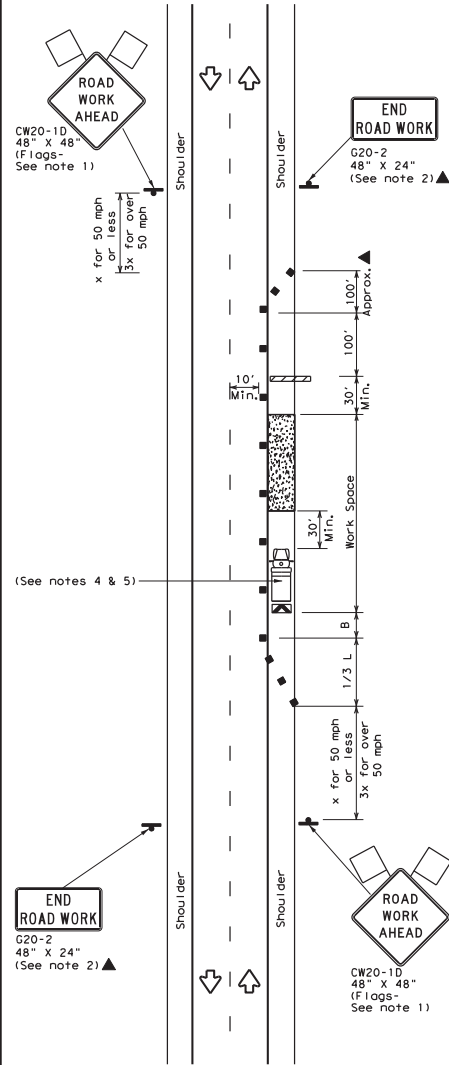

TCP (2-1b)

**WORK SPACE ON SHOULDER**  
 Conventional Roads

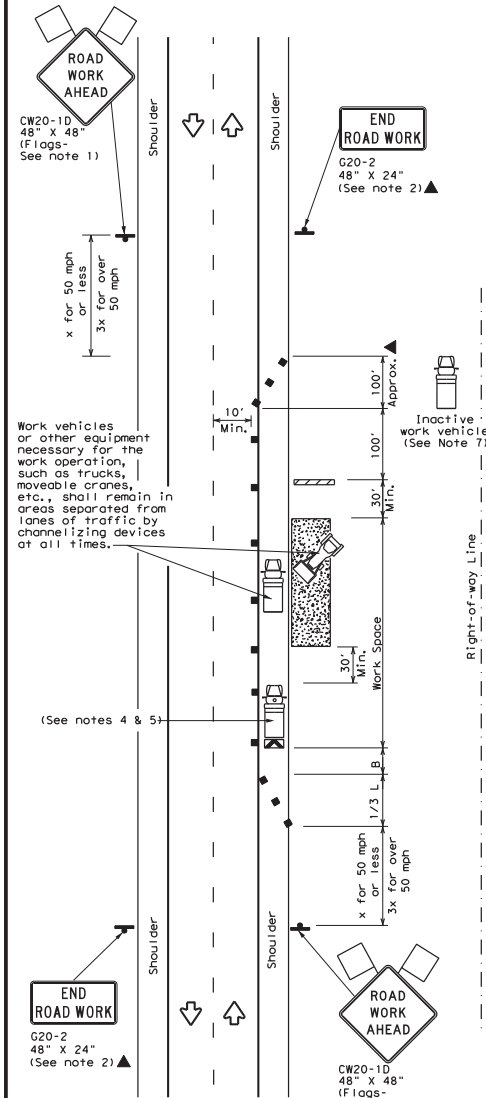

TCP (2-1c)

**WORK VEHICLES ON SHOULDER**  
 Conventional Roads

LEGEND			
	Type 3 Barricade		Channelizing Devices
	Heavy Work Vehicle		Truck Mounted Attenuator (TMA)
	Trailer Mounted Flashing Arrow Board		Portable Changeable Message Sign (PCMS)
	Sign		Traffic Flow
	Flag		Flagger

Posted Speed * *	Formula	Minimum Desirable Taper Lengths * *			Suggested Maximum Spacing of Channelizing Devices		Minimum Sign Spacing * *	Suggested Longitudinal Buffer Space * *
		10' Offset	11' Offset	12' Offset	On a Taper	On a Tangent		
30	$L = \frac{WS^2}{60}$	150'	165'	180'	30'	60'	120'	90'
35		205'	225'	245'	35'	70'	160'	120'
40		265'	295'	320'	40'	80'	240'	155'
45	$L = WS$	450'	495'	540'	45'	90'	320'	195'
50		500'	550'	600'	50'	100'	400'	240'
55		550'	605'	660'	55'	110'	500'	295'
60		600'	660'	720'	60'	120'	600'	350'
65		650'	715'	780'	65'	130'	700'	410'
70	700'	770'	840'	70'	140'	800'	475'	
75	750'	825'	900'	75'	150'	900'	540'	

\* Conventional Roads Only  
 \*\* Taper lengths have been rounded off.  
 L=Length of Taper (FT) W=Width of Offset (FT) S=Posted Speed (MPH)

TYPICAL USAGE				
MOBILE	SHORT DURATION	SHORT TERM STATIONARY	INTERMEDIATE TERM STATIONARY	LONG TERM STATIONARY
	✓		✓	✓

- GENERAL NOTES**
- Flags attached to signs where shown, are REQUIRED.
  - All traffic control devices illustrated are REQUIRED, except those denoted with the triangle symbol may be omitted when stated in the plans, or for routine maintenance work, when approved by the Engineer.
  - Stockpiled material should be placed a minimum of 30 feet from nearest traveled way.
  - Shadow Vehicle with TMA and high intensity rotating, flashing, oscillating or strobe lights. A Shadow Vehicle with a TMA should be used anytime it can be positioned 30 to 100 feet in advance of the area of crew exposure without adversely affecting the performance or quality of the work. If workers are no longer present but road or work conditions require the traffic control to remain in place, Type 3 Barricades or other channelizing devices may be substituted for the Shadow Vehicle and TMA.
  - Additional Shadow Vehicles with TMAs may be positioned off the paved surface, next to those shown in order to protect a wider work space.
  - See TCP(5-1) for shoulder work on divided highways, expressways and freeways.
  - Inactive work vehicles or other equipment should be parked near the right-of-way line and not parked on the paved shoulder.
  - CW21-5 "SHOULDER WORK" signs may be used in place of CW21-1D "ROAD WORK AHEAD" signs for shoulder work on conventional roadways.



**TRAFFIC CONTROL PLAN**  
**CONVENTIONAL ROAD**  
**SHOULDER WORK**

**TCP (2-1) - 18**

FILE: tcp2-1-18.dgn	DATE: December 1985	CONTRACT: 6379	SECTION: 46	JOB: 001	SHEET: SH 320, ETC
2-94 4-98	REVISIONS	8-95 2-12	DIST	COUNTY	SHEET NO.
1-97 2-18		WACO	FALLS		27







DISCLAIMER: This standard is governed by the "Texas Engineering Practice Act". No warranty of any kind is made by TxDOT for any purpose whatsoever. TxDOT assumes no responsibility for the conversion of this standard to other formats or for incorrect results or damages resulting from its use.

DATE: 3/23/2021  
 FILE: T:\MACMAINT\...RMC\_Contract\8\Bosef01\ure\_Pvm\Main\FY--2022\FALLS\CADD\SHEETS\STANDARDS\tcp2-4-18.dgn

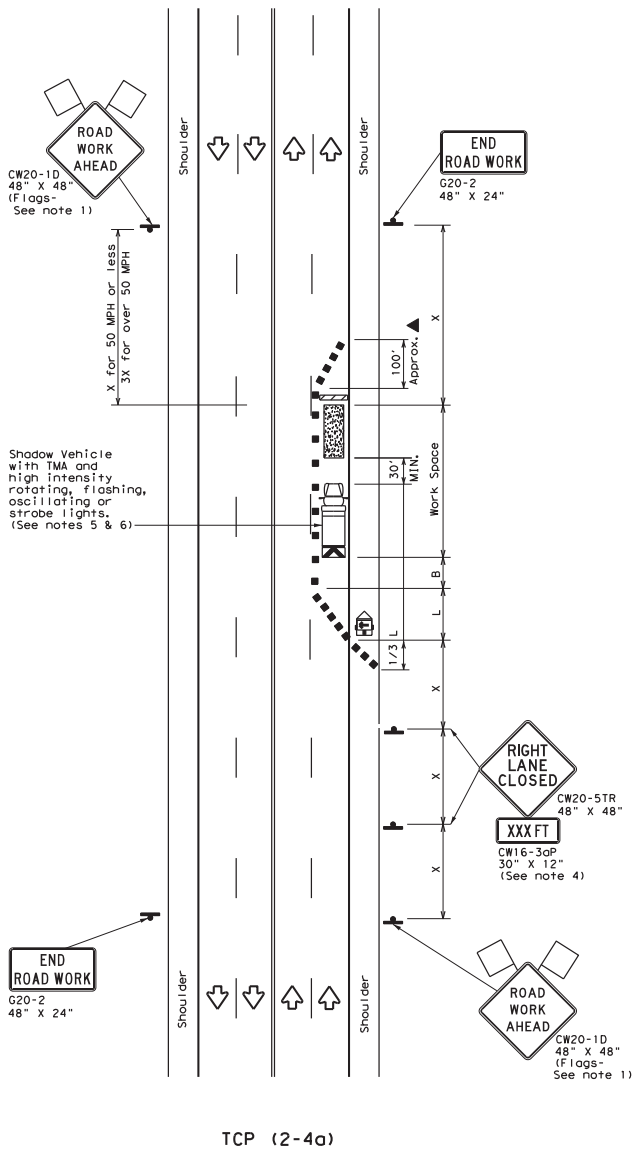

TCP (2-4a)  
**ONE LANE CLOSED**

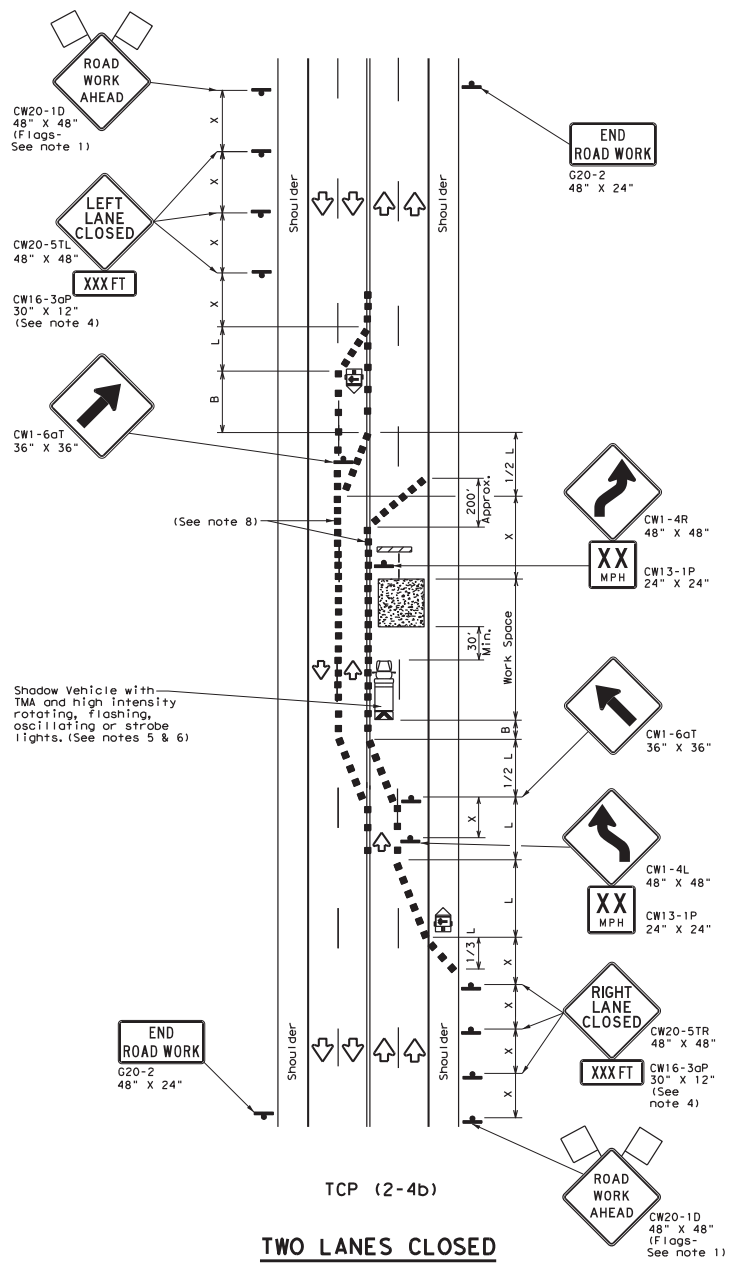

TCP (2-4b)  
**TWO LANES CLOSED**

LEGEND			
	Type 3 Barricade		Channelizing Devices
	Heavy Work Vehicle		Truck Mounted Attenuator (TMA)
	Trailer Mounted Flashing Arrow Board		Portable Changeable Message Sign (PCMS)
	Sign		Traffic Flow
	Flag		Flagger

Posted Speed *	Formula	Minimum Desirable Taper Lengths X*			Suggested Maximum Spacing of Channelizing Devices		Minimum Sign Spacing Distance	Suggested Longitudinal Buffer Space "B"
		10' Offset	11' Offset	12' Offset	On a Taper	On a Tangent		
30	$L = \frac{WS^2}{60}$	150'	165'	180'	30'	60'	120'	90'
35		205'	225'	245'	35'	70'	160'	120'
40		265'	295'	320'	40'	80'	240'	155'
45	L = WS	450'	495'	540'	45'	90'	320'	195'
50		500'	550'	600'	50'	100'	400'	240'
55		550'	605'	660'	55'	110'	500'	295'
60		600'	660'	720'	60'	120'	600'	350'
65		650'	715'	780'	65'	130'	700'	410'
70		700'	770'	840'	70'	140'	800'	475'
75		750'	825'	900'	75'	150'	900'	540'

\* Conventional Roads Only  
 \*\* Taper lengths have been rounded off.  
 L=Length of Taper (FT) W=Width of Offset(FT) S=Posted Speed(MPH)

MOBILE	TYPICAL USAGE			
	SHORT DURATION	SHORT TERM STATIONARY	INTERMEDIATE TERM STATIONARY	LONG TERM STATIONARY
		✓	✓	

- GENERAL NOTES**
- Flags attached to signs where shown, are REQUIRED.
  - All traffic control devices illustrated are REQUIRED, except those denoted with the triangle symbol may be omitted when stated elsewhere in the plans, or for routine maintenance work, when approved by the Engineer.
  - The downstream taper is optional. When used, it should be 100 feet minimum length per lane.
  - For short term applications, when post mounted signs are not used, the distance legend may be shown on the sign face rather than on a CW16-3aP supplemental plaque.
  - A Shadow Vehicle with a TMA should be used anytime it can be positioned 30 to 100 feet in advance of the area of crew exposure without adversely affecting the performance or quality of the work. If workers are no longer present but road or work conditions require the traffic control to remain in place, Type 3 Barricades or other channelizing devices may be substituted for the Shadow Vehicle and TMA.
  - Additional Shadow Vehicles with TMAs may be positioned in each closed lane, on the shoulder or off the paved surface, next to those shown in order to protect a wider work space.
- TCP (2-4a)**
- If this TCP is used for a left lane closure, CW20-5TL "LEFT LANE CLOSED" signs shall be used and channelizing devices shall be placed on the centerline to protect the work space from opposing traffic with the arrow board placed in the closed lane near the end of the merging taper.
- TCP (2-4b)**
- For shorter durations where traffic is directed over a yellow centerline, channelizing devices which separate two-way traffic should be spaced on tapers at 20' or 15' if posted speeds are 35 mph or slower, and for tangent sections, at 1/2(S) where S is the speed in mph. This tighter device spacing is intended for the area of conflicting markings, not the entire work zone.

		Traffic Operations Division Standard	
<b>TRAFFIC CONTROL PLAN LANE CLOSURES ON MULTILANE CONVENTIONAL ROADS</b>			
<b>TCP (2-4) - 18</b>			
FILE: tcp2-4-18.dgn	DATE: December 1985	CONTRACT NO: 6379	SECTION: 46
© TxDOT REVISIONS		JOB NO: 001	SH 320, ETC
8-95 3-01	1-97 2-12	COUNTY: WACO	SHEET NO. 30
4-98 2-18		COUNTY: FALLS	

DISCLAIMER: This standard is governed by the "Texas Engineering Practice Act". No warranty of any kind is made by TxDOT for any purpose whatsoever. TxDOT assumes no responsibility for the conversion of this standard to other formats or for incorrect results or damages resulting from its use.

DATE: 3/23/2021  
 FILE: T:\WACMAINT\1-RMC\_Contract\8-Base\01\ure\_P\mt\m\m\FY-2022\FALLS\CADD\SHEETS\STANDARDS\tcp2-5-18.dgn

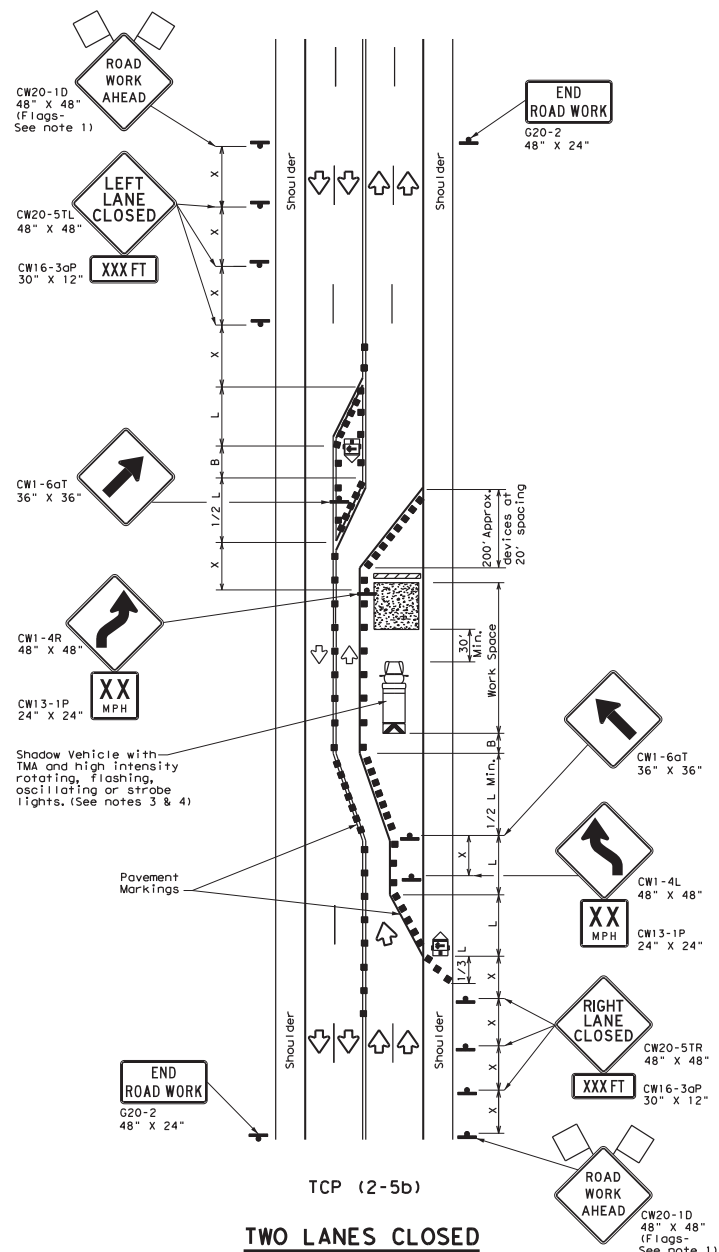
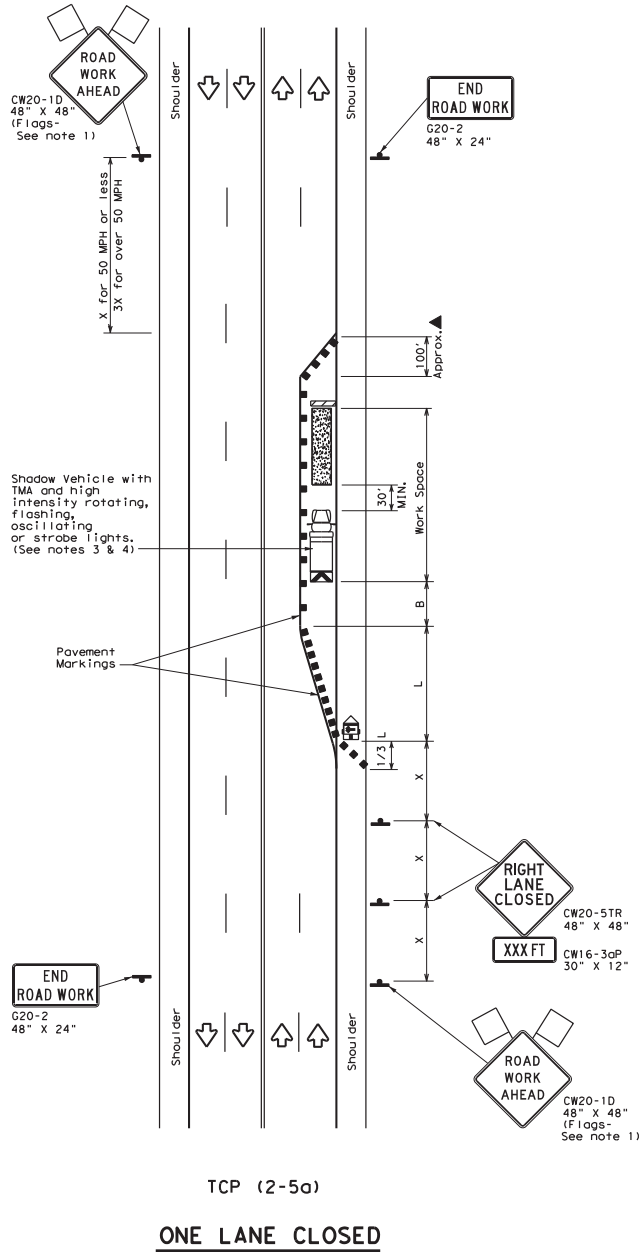

LEGEND			
	Type 3 Barricade		Channelizing Devices
	Heavy Work Vehicle		Truck Mounted Attenuator (TMA)
	Trailer Mounted Flashing Arrow Board		Portable Changeable Message Sign (PCMS)
	Sign		Traffic Flow
	Flag		Flagger

Posted Speed X	Formula	Minimum Desirable Taper Lengths			Suggested Maximum Spacing of Channelizing Devices		Minimum Sign Spacing "X" Distance	Suggested Longitudinal Buffer Space "B"
		10' Offset	11' Offset	12' Offset	On a Taper	On a Tangent		
30	L = WS <sup>2</sup> / 60	150'	165'	180'	30'	60'	120'	90'
35		205'	225'	245'	35'	70'	160'	120'
40	L = WS	265'	295'	320'	40'	80'	240'	155'
45		450'	495'	540'	45'	90'	320'	195'
50	L = WS	500'	550'	600'	50'	100'	400'	240'
55		550'	605'	660'	55'	110'	500'	295'
60	L = WS	600'	660'	720'	60'	120'	600'	350'
65		650'	715'	780'	65'	130'	700'	410'
70	L = WS	700'	770'	840'	70'	140'	800'	475'
75		750'	825'	900'	75'	150'	900'	540'

\* Conventional Roads Only  
 \*\* Taper lengths have been rounded off.  
 L=Length of Taper (FT) W=Width of Offset(FT) S=Posted Speed(MPH)

TYPICAL USAGE				
MOBILE	SHORT DURATION	SHORT TERM STATIONARY	INTERMEDIATE TERM STATIONARY	LONG TERM STATIONARY

- GENERAL NOTES**
- Flags attached to signs where shown, are REQUIRED.
  - All traffic control devices illustrated are REQUIRED, except those denoted with the triangle symbol may be omitted when stated elsewhere in the plans, or for routine maintenance work, when approved by the Engineer.
  - A Shadow Vehicle with a TMA should be used anytime it can be positioned 30 to 100 feet in advance of the area of crew exposure without adversely affecting the performance or quality of the work. If workers are no longer present but road or work conditions require the traffic control to remain in place, Type 3 Barricades or other channelizing devices may be substituted for the Shadow Vehicle and TMA.
  - Additional Shadow Vehicles with TMAs may be positioned in each closed lane, on the shoulder or off the paved surface, next to those shown in order to protect a wider work space.
  - The downstream taper is optional. When used, it should be 100 feet approximately per lane, with channelizing devices spaced at 20 feet.
- TCP (2-5a)**
- If this TCP is used for a left lane closure, CW20-5TL "LEFT LANE CLOSED" signs shall be used and channelizing devices shall be placed on the centerline to protect the work space from opposing traffic, with the arrow board placed in the closed lane near the end of the merging taper.
- TCP (2-5b)**
- Conflicting pavement markings shall be removed for long-term projects.

Traffic Operations Division Standard

## TRAFFIC CONTROL PLAN LONG TERM LANE CLOSURES MULTILANE CONVENTIONAL RDS.

### TCP (2-5) - 18

FILE: tcp2-5-18.dgn	DATE: December 1985	CONTRACT: 6379	SECTION: 46	JOB: 001	SH: 320, ETC
REV: 8-95 2-12	REV: 1-97 3-03	DIST: WACO	COUNTY: FALLS	SHEET NO. 31	

1165

DISCLAIMER: This standard is governed by the "Texas Engineering Practice Act". No warranty of any kind is made by TxDOT for any purpose whatsoever. TxDOT assumes no responsibility for the conversion of this standard to other formats or for incorrect results or damages resulting from its use.

DATE: 3/23/2021  
 FILE: T:\WACMAINT\1-RMC\_Contract\8-Base\01\ure\_Pvm\Main\FY-2022\FALLS\GADD\SHEETS\STANDARDS\tcp2-6-18.dgn

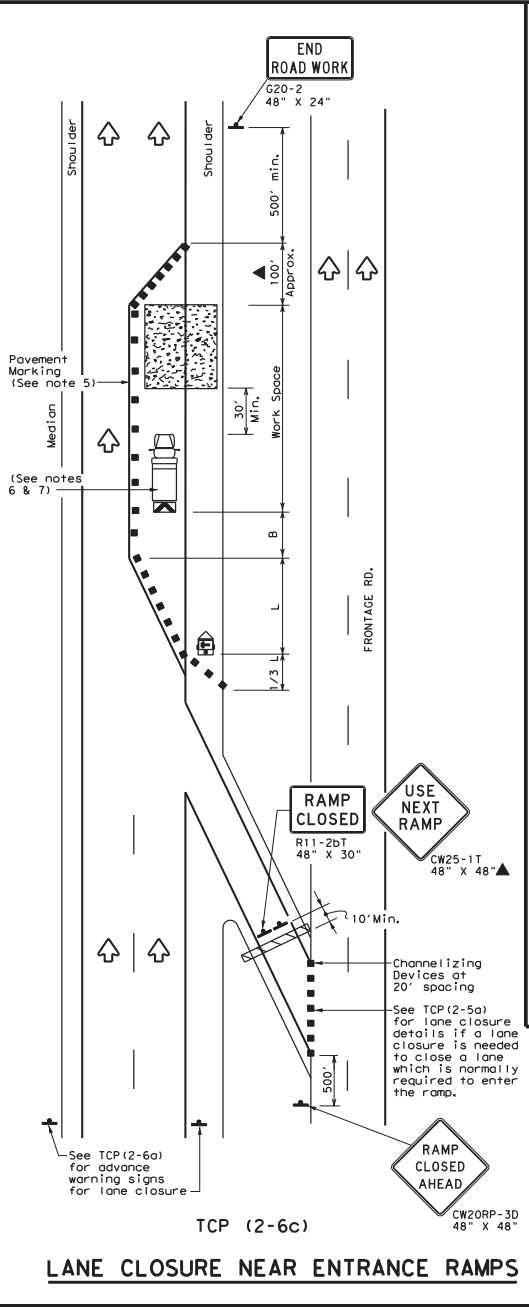
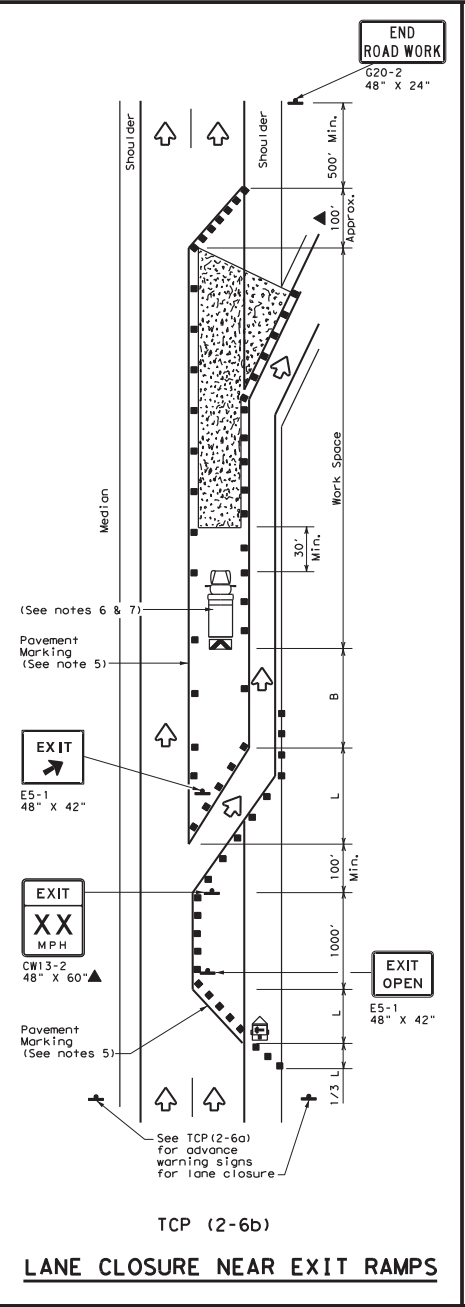
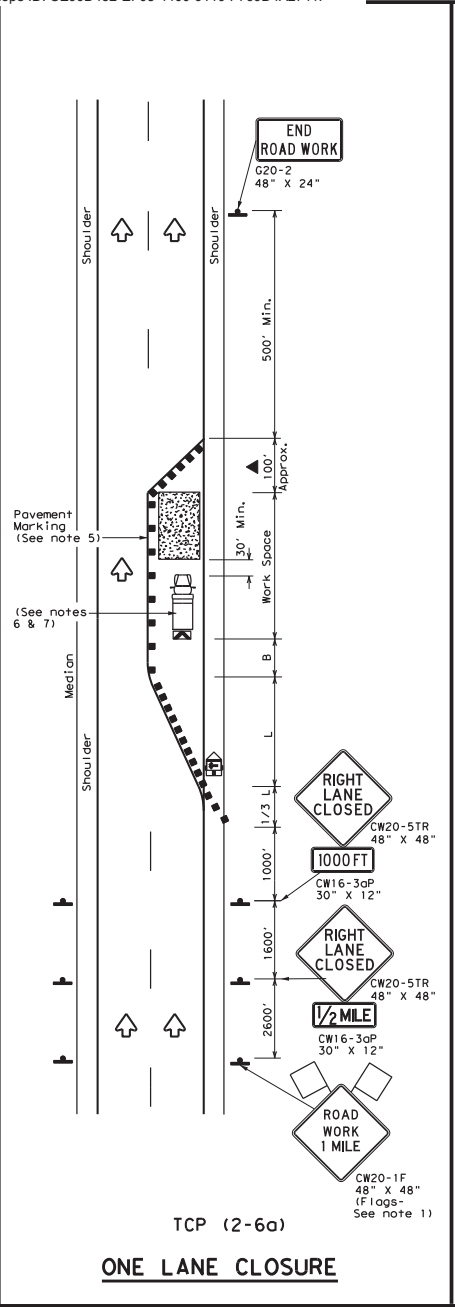

LEGEND	
	Type 3 Barricade
	Channelizing Devices
	Truck Mounted Attenuator (TMA)
	Heavy Work Vehicle
	Trailer Mounted Flashing Arrow Board
	Portable Changeable Message Sign (PCMS)
	Sign
	Flag
	Traffic Flow
	Flagger

Posted Speed * *	Formula	Minimum Desirable Spacing of Taper Lengths **			Suggested Maximum Spacing of Channelizing Devices		Minimum Sign Spacing ** Distance	Suggested Longitudinal Buffer Space "B"
		10' Offset	11' Offset	12' Offset	On a Taper	On a Tangent		
30	L = WS / 60	150'	165'	180'	30'	60'	120'	90'
35		205'	225'	245'	35'	70'	160'	120'
40	L = WS	265'	295'	320'	40'	80'	240'	155'
45		450'	495'	540'	45'	90'	320'	195'
50	L = WS	500'	550'	600'	50'	100'	400'	240'
55		550'	605'	660'	55'	110'	500'	295'
60	L = WS	600'	660'	720'	60'	120'	600'	350'
65		650'	715'	780'	65'	130'	700'	410'
70	L = WS	700'	770'	840'	70'	140'	800'	475'
75		750'	825'	900'	75'	150'	900'	540'

\* Conventional Roads Only  
 \*\* Taper lengths have been rounded off.  
 L=Length of Taper (FT) W=Width of Offset (FT) S=Posted Speed (MPH)

TYPICAL USAGE			
MOBILE	SHORT DURATION	SHORT TERM STATIONARY	LONG TERM STATIONARY

- GENERAL NOTES**
- Flags attached to signs where shown, are REQUIRED.
  - All traffic control devices illustrated are REQUIRED, except those denoted with the triangle symbol may be omitted when stated elsewhere in the plans, or for routine maintenance work, when approved by the Engineer.
  - Channelizing devices used to close lanes may be supplemented with the Chevron Alignment Sign placed on every other channelizing device. Chevrons may be attached to plastic drums as per BC Standards.
  - Channelizing devices used along the work space or along tangent sections may be supplemented with vertical panels (VP) placed on every other channelizing device. If night time conditions make it difficult to see at least two VPs, the VPs may be placed on each channelizing device.
  - The placement of pavement markings may be omitted on intermediate-term stationary work zones with the approval of the Engineer.
  - Shadow Vehicle with TMA and high intensity rotating, flashing, oscillating or strobe lights. Shadow Vehicle with TMA and high intensity rotating, flashing, oscillating or strobe lights. A Shadow Vehicle with a TMA should be used anytime it can be positioned 30 to 100 feet in advance of the area of crew exposure without adversely affecting the performance or quality of the work. If workers are no longer present but road or work conditions require the traffic control to remain in place, Type 3 Barricades or other channelizing devices may be substituted for the Shadow Vehicle and TMA.
  - Additional Shadow Vehicles with TMAs may be positioned in each closed lane, on the shoulder or off the paved surface, next to those shown in order to protect a wider work space.

Texas Department of Transportation  
 Traffic Operations Division Standard

**TRAFFIC CONTROL PLAN  
 LANE CLOSURES ON  
 DIVIDED HIGHWAYS**

**TCP (2-6) - 18**

FILE: tcp2-6-18.dgn	DATE: 08/23/18	BY: [Signature]	CHK: [Signature]	DATE: 08/23/18	CHK: [Signature]
© TxDOT December 1985	6379	46	001	SH 320, ETC	
2-94 4-98	8-95 2-12	1-97 2-18	WACO	FALLS	32
					166



DISCLAIMER: This standard is governed by the "Texas Engineering Practice Act". No warranty of any kind is made by TxDOT for any purpose whatsoever. TxDOT assumes no responsibility for the conversion of this standard to other formats or for incorrect results or damages resulting from its use.

DATE: 3/23/2021 9:45:33 AM  
 FILE: T:\MACMINTY\TMC-Contr\cfrs\Bosef01\ure-P\m\m\m\FY-2022\FALLS\XADD\SHEETS\STANDARDS\tcp3-2-13.dgn

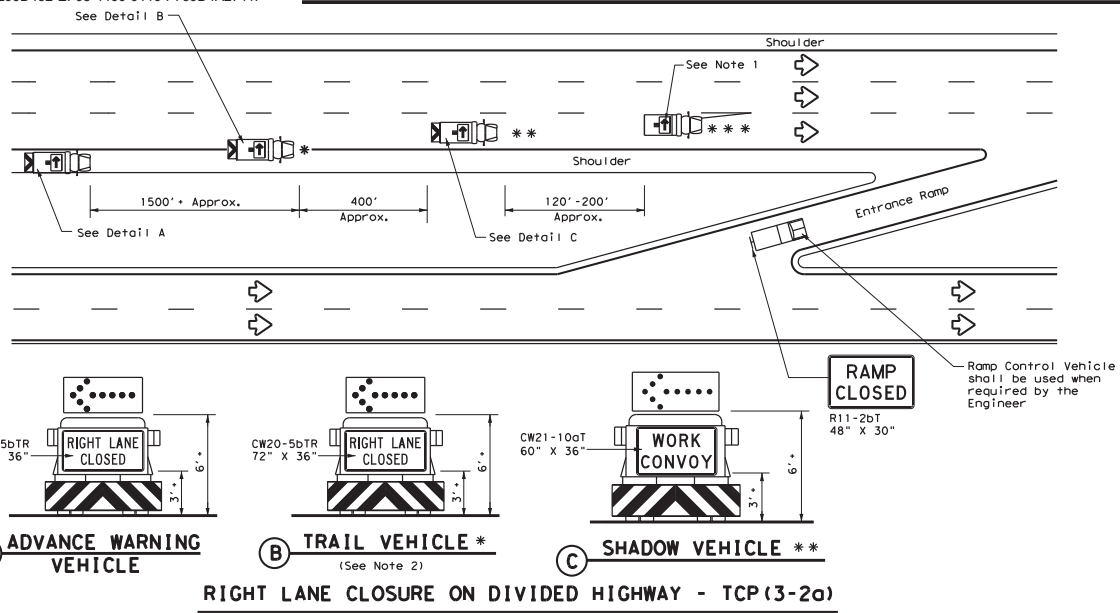

**RIGHT LANE CLOSURE ON DIVIDED HIGHWAY - TCP(3-2a)**

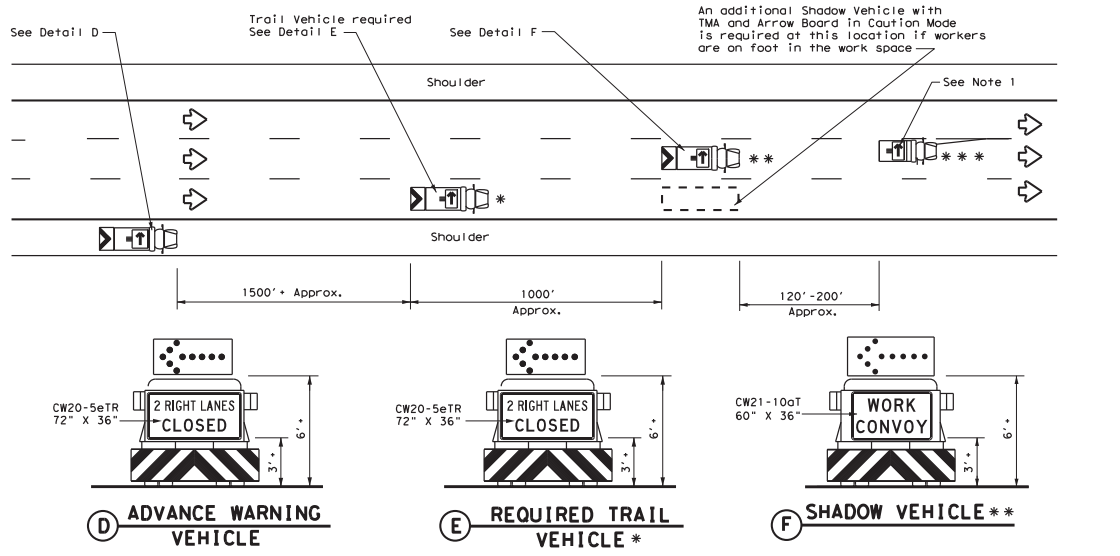

**INTERIOR LANE CLOSURE ON MULTI-LANE DIVIDED HIGHWAY - TCP(3-2b)**

LEGEND		
* Trail Vehicle		ARROW BOARD DISPLAY
** Shadow Vehicle		
*** Work Vehicle		RIGHT Directional
		LEFT Directional
		Double Arrow
		CAUTION (Alternating Diamond or 4 Corner Flash)

TYPICAL USAGE				
MOBILE	SHORT DURATION	SHORT TERM STATIONARY	INTERMEDIATE TERM STATIONARY	LONG TERM STATIONARY
<input checked="" type="checkbox"/>	<input type="checkbox"/>	<input type="checkbox"/>	<input type="checkbox"/>	<input type="checkbox"/>

**GENERAL NOTES**

- ADVANCE WARNING, TRAIL and SHADOW vehicles shall be equipped with Type B or Type C flashing arrow boards as per the Barricade and Construction (BC) standards. Arrow boards on WORK vehicles will be optional based on the type of work being performed. The arrow boards shall be operated from inside the vehicle.
- For TCP(3-2a) the Engineer will determine if the TRAIL VEHICLE is required based on prevailing roadway conditions, traffic volume, and sight distance restrictions. All other vehicles shown for both TCP(3-2a) and TCP(3-2b) are required.
- The use of amber high intensity rotating, flashing, oscillating, or strobe lights on vehicles are required. Blue high intensity rotating, flashing, oscillating or strobe lights when mounted on the driver's side of the vehicle may be operated simultaneously with the amber beacons or strobe lights.
- The use of truck mounted attenuators (TMA) on the ADVANCE WARNING, SHADOW, and TRAIL vehicles are required.
- Reflective sheeting on the rear of the TMA shall meet or exceed the reflectivity and color requirements of DMS 8300, Type A.
- Each vehicle shall have two-way radio communication capability.
- When work convoys must change lanes, the TRAIL VEHICLE should change lanes first to shadow the other convoy vehicles.
- Vehicle spacing between the TRAIL VEHICLE and the SHADOW VEHICLE will vary depending on sight distance restrictions. Motorists approaching the work convoy should be able to see the TRAIL VEHICLE in time to slow down and/or change lanes as they approach the TRAIL VEHICLE. Vehicle spacing between the WORK VEHICLE and SHADOW VEHICLE may vary according to terrain, work activity and other factors.
- Standard 48" X 48" diamond shaped warning signs with the same message as those shown may be used where adequate mounting space exists.
- The signs shown should be used on the Advance Warning Vehicle. As an option, a portable changeable message sign (PCMS) or a truck mounted changeable message sign (TMCMS) with a minimum character height of 12", and displaying the same legend may be substituted for these signs. An appropriate directional arrow display, simulating the size and legibility of the flashing arrow board, must be used in the second phase of the PCMS/TMCMS message. When this is done, the arrow board will not be required on the Advance Warning Vehicle.
- Standard diamond shape versions of the CW20-5 series signs may be used as an option if the rectangular signs shown are not available.
- The principles on this sheet may be used to close lanes from the left side of the roadway considering the number of lanes, shoulder width, sight distance, and ramp frequency.
- Signs and flashing arrow board modes shall be appropriately altered when implementing left lane closures or interior closures which close the left lanes.
- The Advance Warning Vehicle may straddle the edgeline when shoulder width makes it necessary.

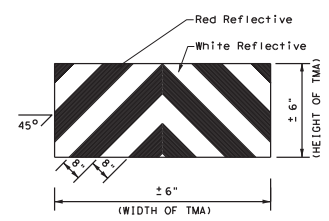

**STRIPING FOR TMA**

		Traffic Operations Division Standard	
<b>TRAFFIC CONTROL PLAN MOBILE OPERATIONS DIVIDED HIGHWAYS</b>			
<b>TCP(3-2)-13</b>			
FILE: tcp3-2.dgn	DN: TxDOT	CR: TxDOT	DR: TxDOT
© TxDOT December 1985	CONT SECT	JOB	HIGHWAY
2-94 4-91 REVISIONS	6379 46	001	SH 320, ETC
8-95 7-13	DIST	COUNTY	SHEET NO.
1-97	WACO	FALLS	34

DISCLAIMER: This standard is governed by the "Texas Engineering Practice Act". No warranty of any kind is made by TxDOT for any purpose whatsoever. TxDOT assumes no responsibility for the conversion of this standard to other formats or for incorrect results or damages resulting from its use.

DATE: 3/23/2021 9:45:36 AM  
 FILE: T:\MCD\INT\TMC\_Contractors\Base\Fig1\ure\_Pvm\Int\TMC\_Standards\Sheet3-3-14.dgn

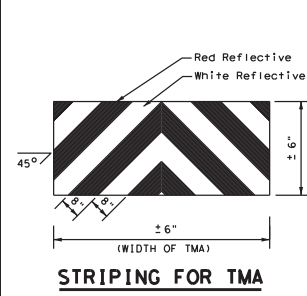
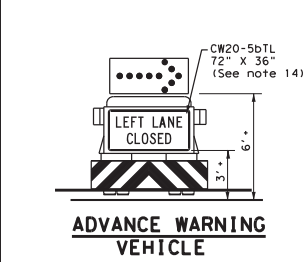
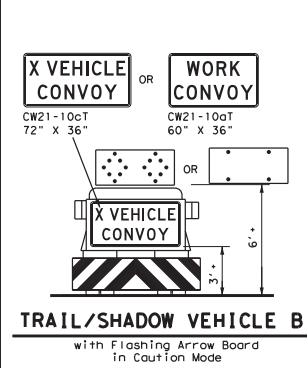
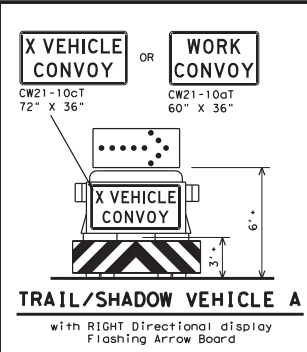
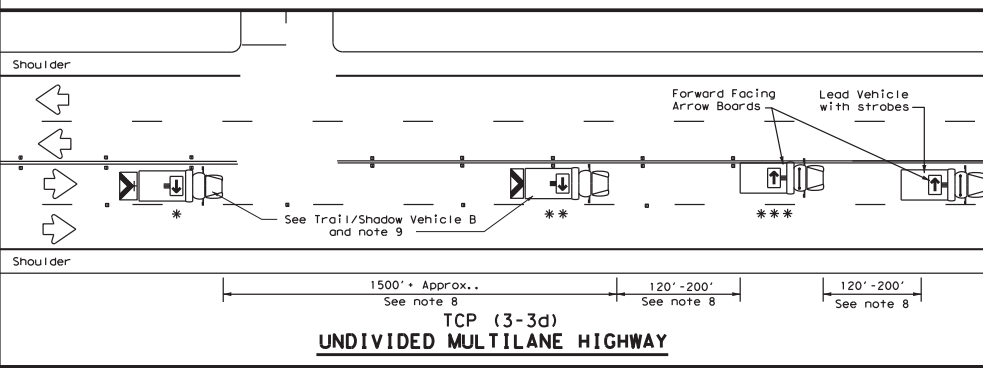
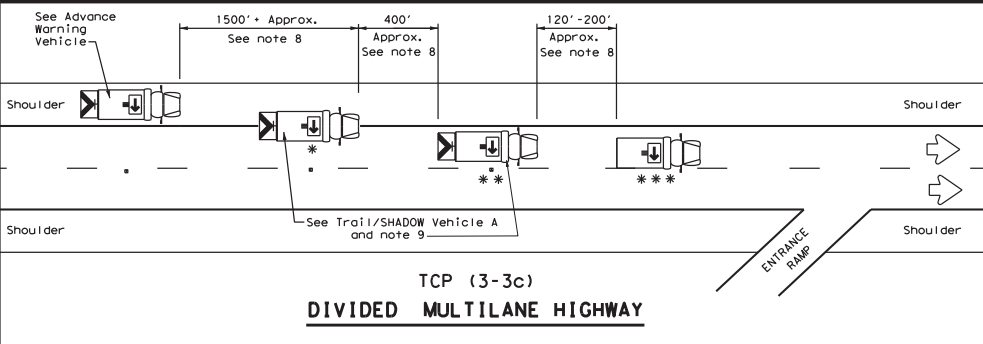
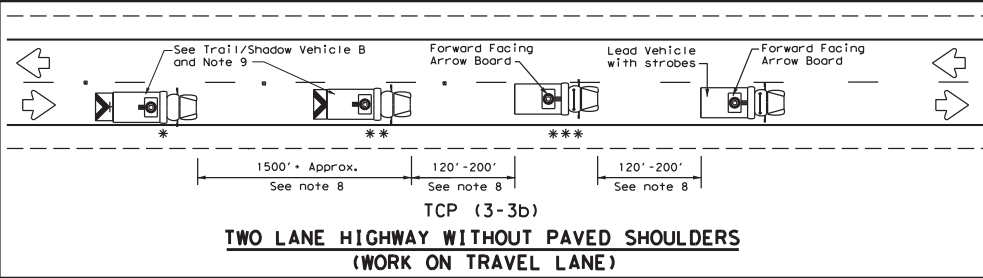
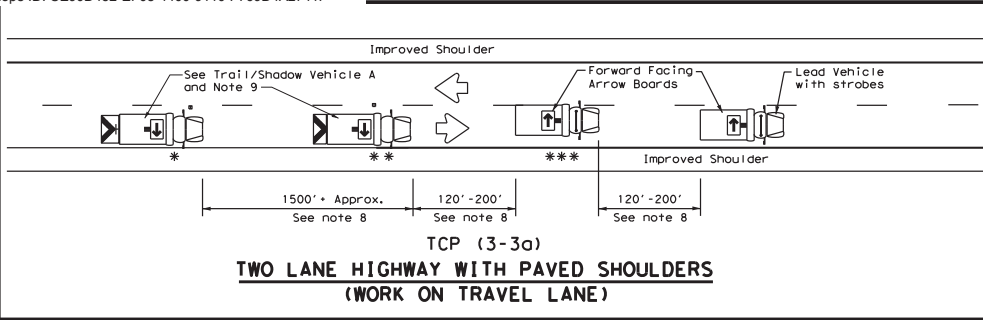

LEGEND		ARROW BOARD DISPLAY	
*	Trail Vehicle		
**	Shadow Vehicle		
***	Work Vehicle		RIGHT Directional
	Heavy Work Vehicle		LEFT Directional
	Truck Mounted Attenuator (TMA)		Double Arrow
	Traffic Flow		CAUTION (Alternating Diamond or 4 Corner Flash)

TYPICAL USAGE				
MOBILE	SHORT DURATION	SHORT TERM STATIONARY	INTERMEDIATE TERM STATIONARY	LONG TERM STATIONARY
✓				

- GENERAL NOTES**
- TRAIL, SHADOW, and LEAD vehicles shall be equipped with arrow boards as illustrated. When a LEAD vehicle is not used on two way roads the WORK vehicle must have an arrow board. For divided roadways, the arrow board on the WORK vehicle is optional based on the type of work being performed. The Engineer will determine if the LEAD vehicle and/or TRAIL vehicle are required based on prevailing roadway conditions, traffic volume, and sight distance restrictions.
  - The use of amber high intensity rotating, flashing, oscillating, or strobe lights on vehicles are required. Blue high intensity rotating, flashing, oscillating, or strobe lights when mounted on the driver's side of the vehicle may be operated simultaneously with the amber beacons or strobe lights.
  - The use of truck mounted attenuators (TMA) on the SHADOW VEHICLE, ADVANCE WARNING and TRAIL VEHICLE are required.
  - Reflective sheeting on the rear of the TMA shall meet or exceed the reflectivity and color requirements of DEPARTMENTAL MATERIAL SPECIFICATION DMS 8300, Type A.
  - Flashing arrow boards shall be Type B or Type C as per the Barricade and Construction (BC) standards. The board shall be controlled from inside the vehicle.
  - Each vehicle shall have two-way radio communication capability.
  - When work convoys must change lanes, the TRAIL VEHICLE should change lanes first to shadow the other convoy vehicles.
  - Vehicle spacing between the TRAIL VEHICLE and the SHADOW VEHICLE will vary depending on sight distance restrictions. Motorists approaching the convoy should be able to see the TRAIL VEHICLE in time to slow down and/or change lanes as they approach the TRAIL VEHICLE. Vehicle spacing between the WORK VEHICLE and SHADOW VEHICLE and vehicle spacing between WORK VEHICLE and LEAD VEHICLE may vary according to terrain, work activity and other factors.
  - X VEHICLE CONVOY (CW21-10cT) or WORK CONVOY (CW21-10aT) signs shall be used on TRAIL VEHICLES and SHADOW VEHICLES as shown. As an option 48" x 48" diamond shaped WORK CONVOY (CW21-10T) or X VEHICLE CONVOY (CW21-10bT) signs may be used where adequate mounting space exists. When used, the X VEHICLE CONVOY sign shall have the number of the convoy vehicles displayed on the sign in the number designation "X" location. The X VEHICLE CONVOY sign shall not be used on the SHADOW VEHICLE if a TRAIL VEHICLE is used.
  - For divided highways with two or three lanes in one direction, the appropriate LEFT LANE CLOSED (CW20-5bTL), RIGHT LANE CLOSED (CW20-5bTR), or CENTER LANE CLOSED (CW20-5bT) sign should be used on the Advance Warning Vehicle. As an option, a portable changeable message sign (PCMS) or truck mounted changeable message sign (TMCMS) with a minimum character height of 12", and displaying the same legend may be substituted for these signs. An appropriate directional arrow display, simulating the size and legibility of the flashing arrow board may be used in the second phase of the PCMS/TMCMS message. When this is done, the arrow board will not be required on the Advance Warning Vehicle.
  - A double arrow shall not be displayed on the arrow board on the Advance Warning Vehicle.
  - For divided highways with three or four lanes in each direction, use TCP(3-2).
  - Standard diamond shape versions of the CW20-5 series signs may be used as an option if the rectangular signs shown are not available.
  - The Advance Warning Vehicle may straddle the edge line when Shoulder width makes it necessary.
  - On two-lane two-way roadways, the work and protection vehicles should pull over periodically to allow motor vehicle traffic to pass. If motorists are not allowed to pass the work convoy, a DO NOT PASS (R4-1) sign should be placed on the back of the rearmost protection vehicle.

**TRAFFIC CONTROL PLAN**  
**MOBILE OPERATIONS**  
**RAISED PAVEMENT**  
**MARKER INSTALLATION/**  
**REMOVAL**  
**TCP (3-3) - 14**

FILE: tcp3-3.dgn	DN: TxDOT	CR: TxDOT	DR: TxDOT	CHK: TxDOT
© TxDOT September 1987	CONT: 6379	SECT: 46	JOB: 001	HIGHWAY: SH 320, ETC
2-94 4-91 REVISIONS	DIST: WACO	COUNTY: FALLS	SHEET NO. 35	
8-95 7-13				
1-97 7-14				

177

DISCLAIMER: This standard is governed by the "Texas Engineering Practice Act". No warranty of any kind is made by TxDOT for any purpose whatsoever. TxDOT assumes no responsibility for the conversion of this standard to other formats or for incorrect results or damages resulting from its use.

DATE: 3/23/2021 9:45:40 AM  
 FILE: T:\MACMINTY\TMC\Contractors\Bosefoglure\_Pvm\Main\FY-2022\FALLS\CADD\SHEETS\STANDARDS\tcp3-4-13.dgn

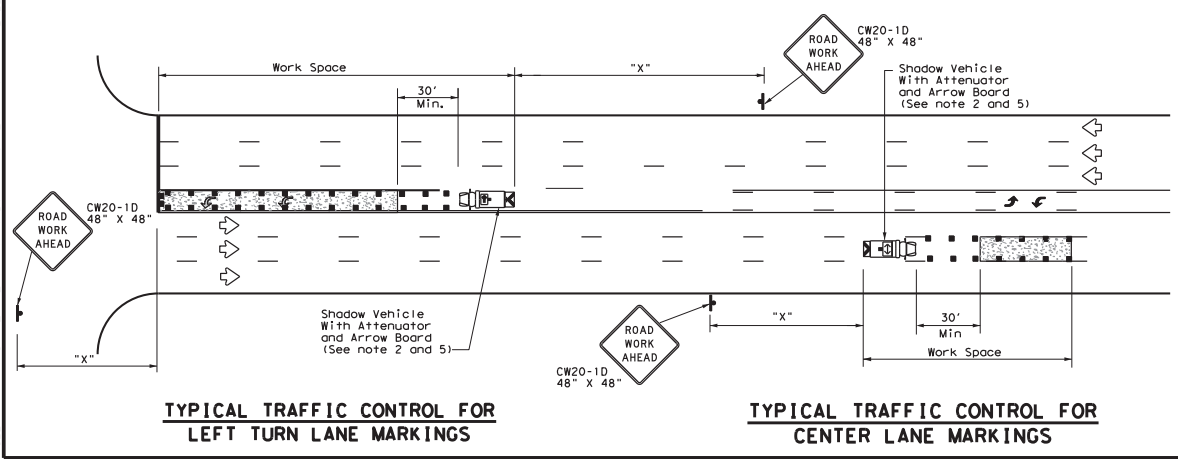
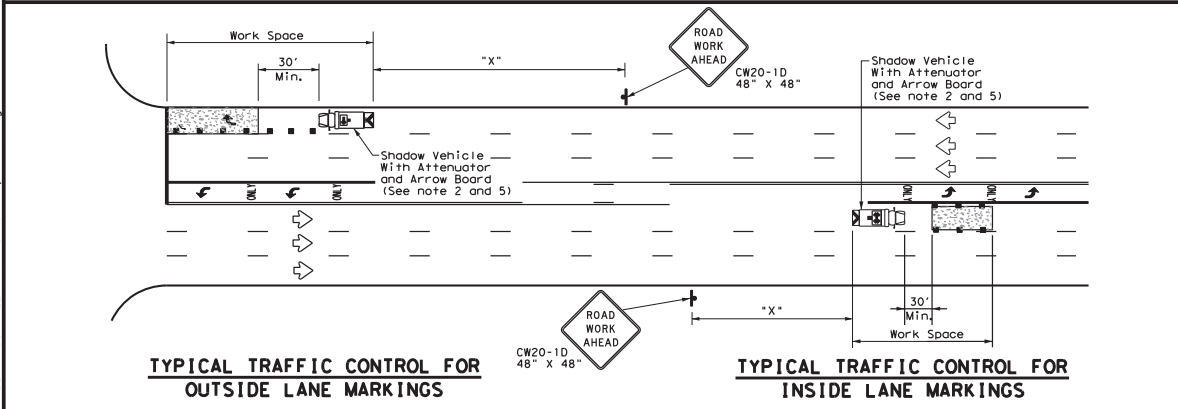
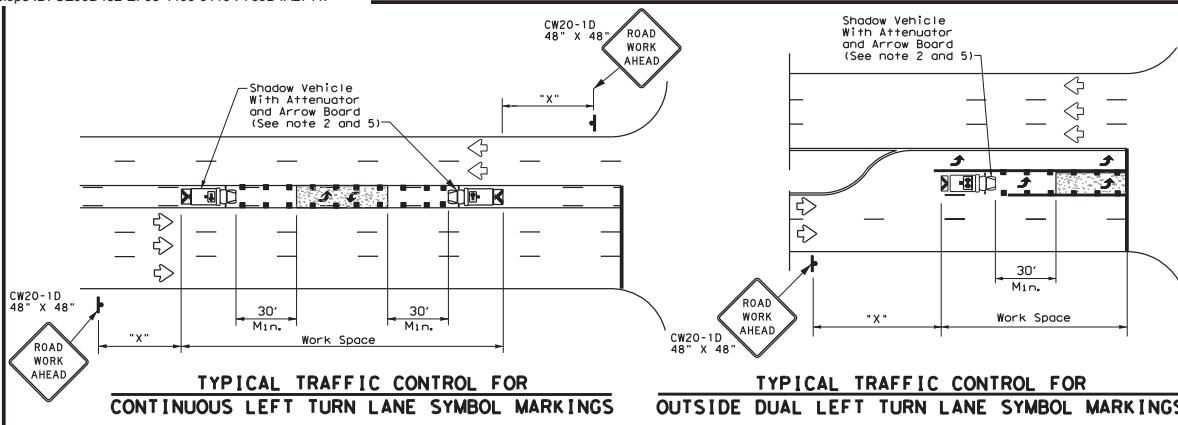

LEGEND	
* Trail Vehicle	ARROW BOARD DISPLAY
** Shadow Vehicle	
*** Work Vehicle	RIGHT Directional
Heavy Work Vehicle	LEFT Directional
Truck Mounted Attenuator (TMA)	Double Arrow
Traffic Flow	Channelizing Devices

Posted Speed * *	Formula	Minimum Desirable Taper Lengths **			Suggested Maximum Spacing of Channelizing Devices		Minimum Sign Spacing *' Distance	Suggested Longitudinal Buffer Space 'B'
		10' Offset	11' Offset	12' Offset	On a Taper	On a Tangent		
30	$L = \frac{WS^2}{60}$	150'	165'	180'	30'	60'	120'	90'
35		205'	225'	245'	35'	70'	160'	120'
40		265'	295'	320'	40'	80'	240'	155'
45	L=WS	450'	495'	540'	45'	90'	320'	195'
50		500'	550'	600'	50'	100'	400'	240'
55		550'	605'	660'	55'	110'	500'	295'
60		600'	660'	720'	60'	120'	600'	350'
65		650'	715'	780'	65'	130'	700'	410'
70		700'	770'	840'	70'	140'	800'	475'
75		750'	825'	900'	75'	150'	900'	540'

\* Conventional Roads Only  
 \*\* Taper lengths have been rounded off.  
 L=Length of Taper (FT) W=Width of Offset (FT) S=Posted Speed (MPH)

TYPICAL USAGE			
MOBILE	SHORT DURATION	SHORT TERM STATIONARY	LONG TERM STATIONARY
✓			

**GENERAL NOTES**

1. This traffic control plan is for use on conventional roads posted at 45 mph or less and is intended for mobile operations that move continuously or intermittently (stopping up to approximately 15 minutes) such as short-line striping and in-lane rumble strips. When activities are anticipated to take longer amounts of time or traffic conditions warrant, a short duration or short-term stationary traffic control plan should be used.
2. A Truck Mounted Attenuator shall be used on Shadow Vehicle. Striping on the back panel of all truck mounted attenuators shall be 8" red and white reflective sheeting placed in an inverted "V" design. Reflective sheeting shall meet or exceed the reflectivity and color requirements of departmental material specification DMS-8300, Type A.
3. All traffic control devices shall be in accordance with the "Texas Manual on Uniform Traffic Control Devices" (TMUTCD), latest edition.
4. The use of yellow rotating beacons or strobe lights on vehicles are required. Blue high intensity rotating, flashing, oscillating or strobe lights when mounted on the drivers side of the vehicle may be operated simultaneously with the amber beacons or strobe lights.
5. Flashing arrow board shall be used on Shadow Vehicle. Flashing arrow board shall be Type B or Type C as per BC Standards. The arrow board operation shall be controlled from inside the truck.

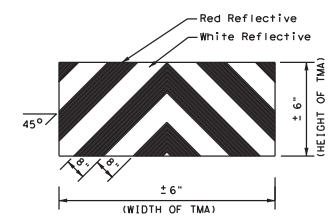

Traffic Operations Division

TRAFFIC CONTROL PLAN  
 MOBILE OPERATIONS FOR  
 ISOLATED WORK AREAS  
 UNDIVIDED HIGHWAYS  
 TCP (3-4) - 13

FILE: tcp3-4.dgn	DN: TxDOT	CR: TxDOT	DR: TxDOT	EX: TxDOT
© TxDOT July, 2013	CONT SECT	JOB	HIGHWAY	
REVISIONS	6379	46	001	SH 320, ETC
DIST	COUNTY		SHEET NO.	
WACO	FALLS		36	



DISCLAIMER: This standard is governed by the "Texas Engineering Practice Act". No warranty of any kind is made by TxDOT for any purpose whatsoever. TxDOT assumes no responsibility for the conversion of this standard to other formats or for incorrect results or damages resulting from its use.

DATE: 3/23/2021  
 FILE: T:\MACMAINT\1-RMC\_Contract\Bases\of\1ure\_P\m\m\m\m\1-18.dgn

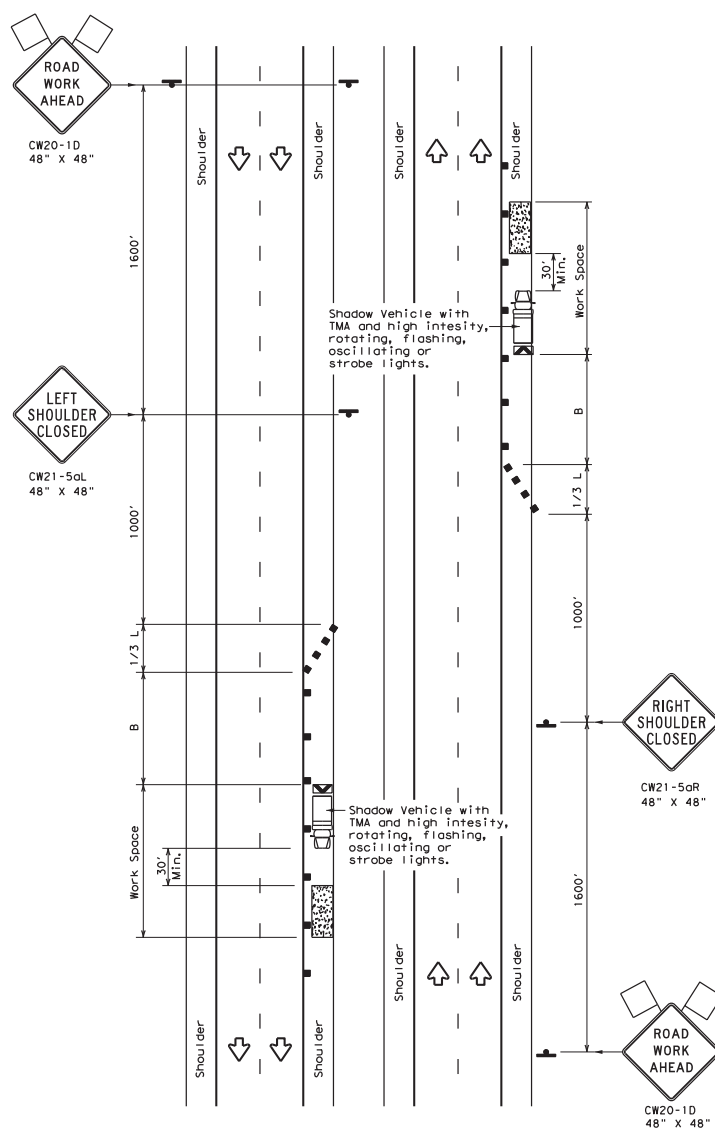

TCP (5-1a)

**WORK AREA ON SHOULDER**

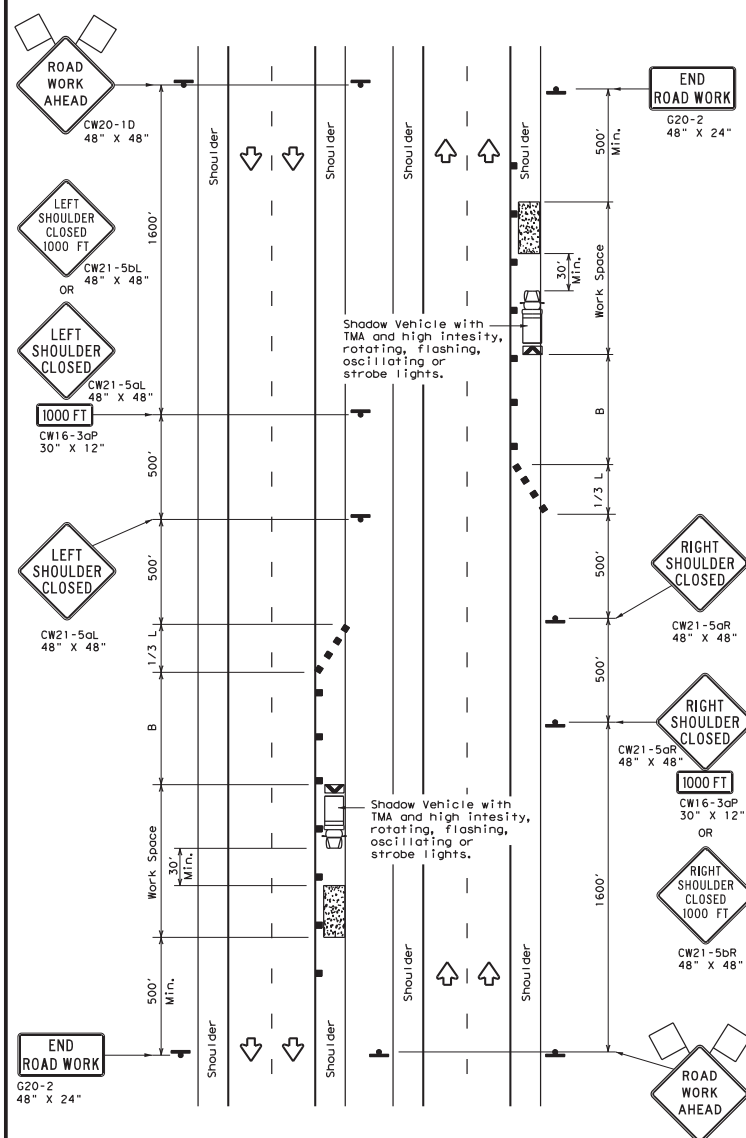

TCP (5-1b)

**WORK AREA ON SHOULDER**

LEGEND			
	Type 3 Barricade		Channelizing Devices
	Heavy Work Vehicle		Truck Mounted Attenuator (TMA)
	Trailer Mounted Flashing Arrow Board		Portable Changeable Message Sign (PCMS)
	Sign		Traffic Flow
	Flag		Flagger

Posted Speed * *	Formula	Minimum Desirable Taper Lengths **			Suggested Maximum Spacing of Channelizing Devices		Suggested Longitudinal Buffer Space "B"
		10' Offset	11' Offset	12' Offset	On a Taper	On a Tangent	
30	L = WS <sup>2</sup> / 60	150'	165'	180'	30'	60'	90'
35		205'	225'	245'	35'	70'	120'
40		265'	295'	320'	40'	80'	155'
45	L = WS	450'	495'	540'	45'	90'	195'
50		500'	550'	600'	50'	100'	240'
55		550'	605'	660'	55'	110'	295'
60	L = WS	600'	660'	720'	60'	120'	350'
65		650'	715'	780'	65'	130'	410'
70		700'	770'	840'	70'	140'	475'
75	L = WS	750'	825'	900'	75'	150'	540'
80		800'	880'	960'	80'	160'	615'

\* Conventional Roads Only  
 \*\* Taper lengths have been rounded off.  
 L=Length of Taper (FT) W=Width of Offset(FT) S=Posted Speed(MPH)

TYPICAL USAGE				
MOBILE	SHORT DURATION	SHORT TERM STATIONARY	INTERMEDIATE TERM STATIONARY	LONG TERM STATIONARY
	TCP (5-1a)	TCP (5-1b)	TCP (5-1b)	

- GENERAL NOTES**
- A Shadow Vehicle with a TMA should be used anytime it can be positioned 30' to 100' in advance of the area of crew exposure without adversely affecting the performance or quality of the work. Type 3 barricades or drums may be substituted when workers on foot are no longer present when approved by the Engineer.
  - 28" tall or taller one-piece cones will be allowed only for Short Duration or Short Term stationary operations when workers are present to maintain the devices upright and in proper location. Intermediate Term stationary work areas should use Drums, Vertical Panels or 42" tall two-piece cones.

Texas Department of Transportation  
 Traffic Operations Division Standard

**TRAFFIC CONTROL PLAN  
 SHOULDER WORK FOR  
 FREEWAYS / EXPRESSWAYS**

**TCP (5-1) - 18**

FILE: tcp5-1-18.dgn	DATE: February 2012	REV: 46	JOB: 001	SH: 320, ETC
2-18	DIST: WACO	COUNTY: FALLS	SHEET NO. 37	

DISCLAIMER: This standard is governed by the "Texas Engineering Practice Act". No warranty of any kind is made by TxDOT for any purpose whatsoever. TxDOT assumes no responsibility for the conversion of this standard to other formats or for incorrect results or damages resulting from its use.

DATE: 3/23/2021 9:45:46 AM  
 FILE: T:\MACMAINT\1\TMC\_Contractors\Bose\01\Ture\_Pvm\Main\FY-2022\FALLS\CAD\STANDARDS\TCP6-1-12.dgn

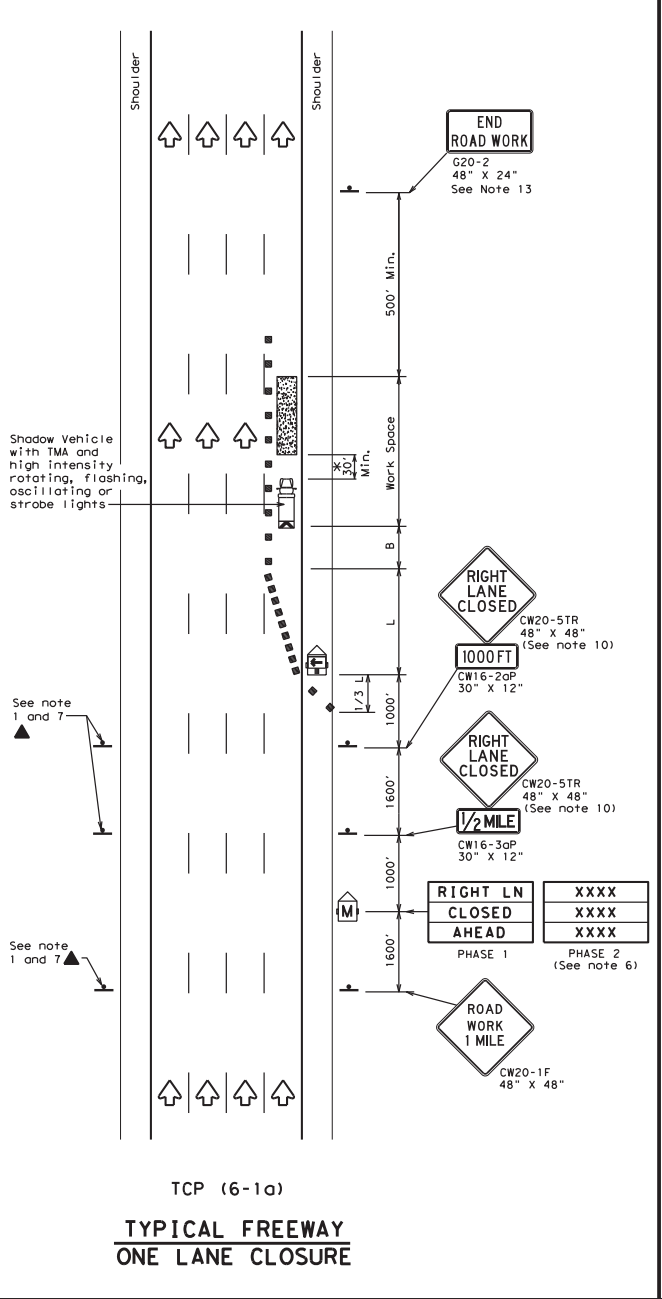

TCP (6-1a)  
**TYPICAL FREEWAY  
 ONE LANE CLOSURE**

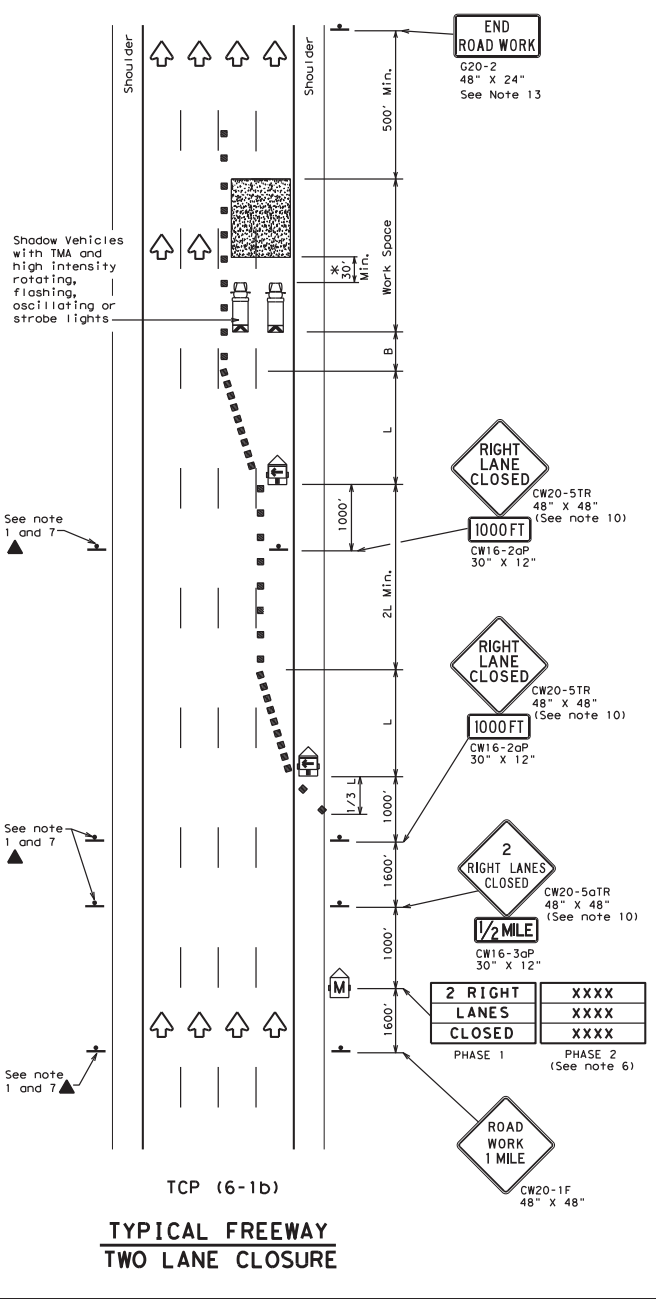

TCP (6-1b)  
**TYPICAL FREEWAY  
 TWO LANE CLOSURE**

LEGEND			
	Type 3 Barricade		Channelizing Devices
	Heavy Work Vehicle		Truck Mounted Attenuator (TMA)
	Trailer Mounted Flashing Arrow Board		Portable Changeable Message Sign (PCMS)
	Sign		Traffic Flow
	Flag		Flagger

Posted Speed	Formula	Minimum Desirable Taper Lengths "L"			Suggested Maximum Spacing of Channelizing Devices		Suggested Longitudinal Buffer Space "B"
		10' Offset	11' Offset	12' Offset	On a Taper	On a Tangent	
45	L = WS	450'	495'	540'	45'	90'	195'
50		500'	550'	600'	50'	100'	240'
55		550'	605'	660'	55'	110'	295'
60		600'	660'	720'	60'	120'	350'
65		650'	715'	780'	65'	130'	410'
70		700'	770'	840'	70'	140'	475'
75		750'	825'	900'	75'	150'	540'
80		800'	880'	960'	80'	160'	615'

\*\*Taper lengths have been rounded off.  
 L=Length of Taper (FT) W=Width of Offset(FT) S=Posted Speed(MPH)

TYPICAL USAGE				
MOBILE	SHORT DURATION	SHORT TERM STATIONARY	INTERMEDIATE TERM STATIONARY	LONG TERM STATIONARY
	✓	✓	✓	

**GENERAL NOTES**

- All traffic control devices illustrated are REQUIRED. Devices denoted with the triangle symbol may be omitted when stated elsewhere in the plans.
- Drums or 42" cones are the typical channelizing devices. For Intermediate Term Stationary work, drums shall be used on tapers with drums or 42" cones used on tangent sections. Other channelizing devices may be used as directed by the Engineer.
- All construction signs and barricades placed during any phase of work shall remain in place until removal is approved by the Engineer.
- The Engineer may direct the Contractor to furnish additional signs and barricades as required to maintain traffic flow, detours and motorist safety during construction.
- Static message boards or changeable message signs stating the date and duration of ramp or freeway lane closures shall be placed a minimum of seven (7) calendar days in advance of the actual closure.
- Phase 2 of the PCMS message should include appropriate information formatted as shown on BC(6), such as "MERGE LEFT," recommended advisory speed, delay information, or other specific warnings.
- Duplicate construction warning signs should be erected on the medians side of freeways where median width will permit and traffic volume justifies the signing.
- The number of closed lanes may be increased provided the spacing of traffic control devices, taper lengths and tangent lengths meet the requirements of the MUTCD.
- Warning signs for intermediate term stationary work should be mounted at 7' to the bottom of the sign.
- Warning signs shown shall be appropriately altered for left lane closures. When signs are mounted at 1' height for short term stationary or short duration work, sign versions shown in the SHSD for Texas with distances on the sign face rather than mounted on a plaque below the sign may be used.
- When possible, PCMS units should be located in advance of the last available exit ramp prior to the lane closure to allow motorists an alternate route. They may also be relocated to improve advance warning in case of unanticipated queuing or congestion.
- For Intermediate Term Stationary work at night, floodlights should be used to illuminate the work area and equipment crossings. Floodlights shall not produce a disabling glare condition for road users or workers.
- The END ROAD WORK (G20-2) sign may be omitted when it conflicts with G20-2 signs already in place on the project.

\*A shadow vehicle equipped with a Truck Mounted Attenuator is typically required. A shadow vehicle equipped with a TMA shall be used if it can be positioned 30' to 100' in advance of the area of crew exposure without adversely affecting the work performance.



**TRAFFIC CONTROL PLAN  
 FREEWAY LANE CLOSURES**

**TCP (6-1) - 12**

FILE:	tcp6-1.dgn	DN:	TxDOT	CR:	TxDOT	DR:	TxDOT	CK:	TxDOT
© TxDOT	February 1998	CONT	SECT	JOB	SH	320, ETC			
8-12	REVISIONS	6379	46	001					
	DIST	WACO		COUNTY	FALLS		SHEET NO. 38		

DISCLAIMER: This standard is governed by the "Texas Engineering Practice Act". No warranty of any kind is made by TxDOT for any purpose whatsoever. TxDOT assumes no responsibility for the conversion of this standard to other formats or for incorrect results or damages resulting from its use.

DATE: 3/23/2021 9:45:49 AM  
 FILE: T:\MACMAINT\1-RMC-Contractors\Base\01\ure\_Pvm\Main\FY-2022\FALLS\CADD\SHEETS\STANDARDS\tcp6-2-12.dgn

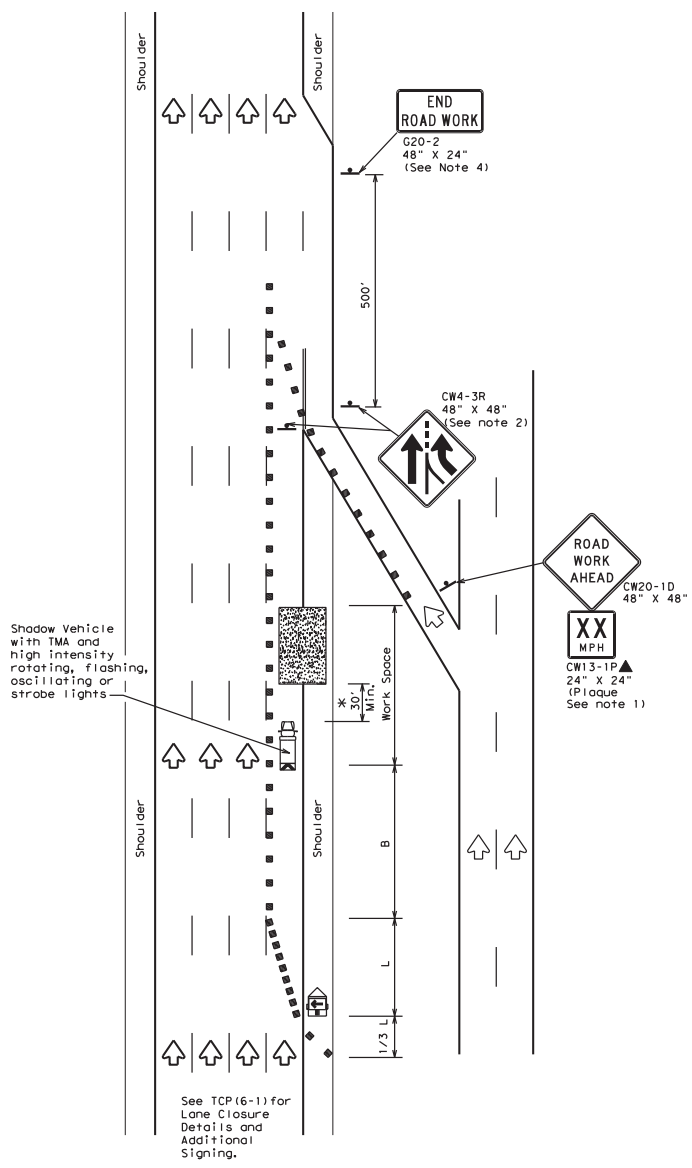

TCP (6-2a)  
**ENTRANCE RAMP OPEN**  
**WORK WITHIN 500' OF RAMP**

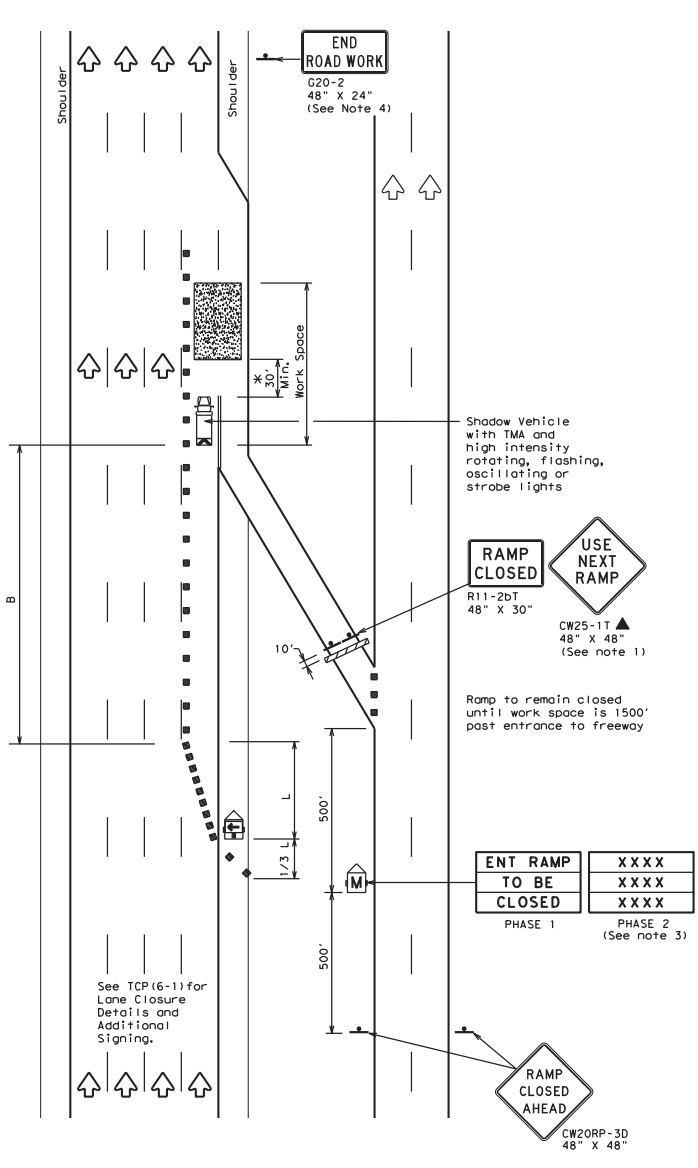

TCP (6-2b)  
**ENTRANCE RAMP CLOSED**

LEGEND			
	Type 3 Barricade		Channelizing Devices
	Heavy Work Vehicle		Truck Mounted Attenuator (TMA)
	Trailer Mounted Flashing Arrow Board		Portable Changeable Message Sign (PCMS)
	Sign		Traffic Flow
	Flag		Flagger

Posted Speed	Formula	Minimum Desirable Taper Lengths "L"		Suggested Maximum Spacing of Channelizing Devices		Suggested Longitudinal Buffer Space "B"	
		10' Offset	12' Offset	On a Taper	On a Tangent		
45	L = WS	450'	495'	540'	45'	90'	195'
50		500'	550'	600'	50'	100'	240'
55		550'	605'	660'	55'	110'	295'
60		600'	660'	720'	60'	120'	350'
65		650'	715'	780'	65'	130'	410'
70		700'	770'	840'	70'	140'	475'
75		750'	825'	900'	75'	150'	540'
80		800'	880'	960'	80'	160'	615'

\*\*Taper lengths have been rounded off.  
 L=Length of Taper (FT) W=Width of Offset (FT) S=Posted Speed (MPH)

TYPICAL USAGE				
MOBILE	SHORT DURATION	SHORT TERM STATIONARY	INTERMEDIATE TERM STATIONARY	LONG TERM STATIONARY
	✓	✓	✓	

**GENERAL NOTES**

- All traffic control devices illustrated are REQUIRED. Devices denoted with the triangle symbol may be omitted when stated elsewhere in the plans.
- ADDED LANE SYMBOL (CW4-3) sign may be omitted when sign between ramp and mainline can be seen from both roadways.
- See "Advance Notice List" on BC(6) for recommended date and time formatting options for PCMS Phase 2 message.
- The END ROAD WORK (G20-2) sign may be omitted when it conflicts with G20-2 signs already in place on the project.

\*A shadow vehicle equipped with a Truck Mounted Attenuator is typically required. A shadow vehicle equipped with a TMA shall be used if it can be positioned 30' to 100' in advance of the area of crew exposure without adversely affecting the work performance.

Additional requirements for lane closures and advance signing shall be as shown on TCP (6-1) or as directed by the Engineer.



**TRAFFIC CONTROL PLAN**  
**WORK AREA NEAR RAMP**

**TCP (6-2) - 12**

FILE: tcp6-2.dgn	DN: TxDOT	CR: TxDOT	DR: TxDOT	CK: TxDOT
REVISIONS	CONT	SECT	JOB	HIGHWAY
1-97 8-98	6379	46	001	SH 320, ETC
4-98 8-12	DIST	COUNTY	WACO	FALLS
				SHEET NO. 39

DISCLAIMER: This standard is governed by the "Texas Engineering Practice Act". No warranty of any kind is made by TxDOT for any purpose whatsoever. TxDOT assumes no responsibility for the conversion of this standard to other formats or for incorrect results or damages resulting from its use.

DATE: 3/23/2021 9:45:52 AM  
 FILE: T:\MACMAINT\RM\Contractors\Bose\011\ure\_P\mt\m\In\FY-2022\FALLS\CADD\SHEETS\STANDARDS\tcp6-3-12.dgn

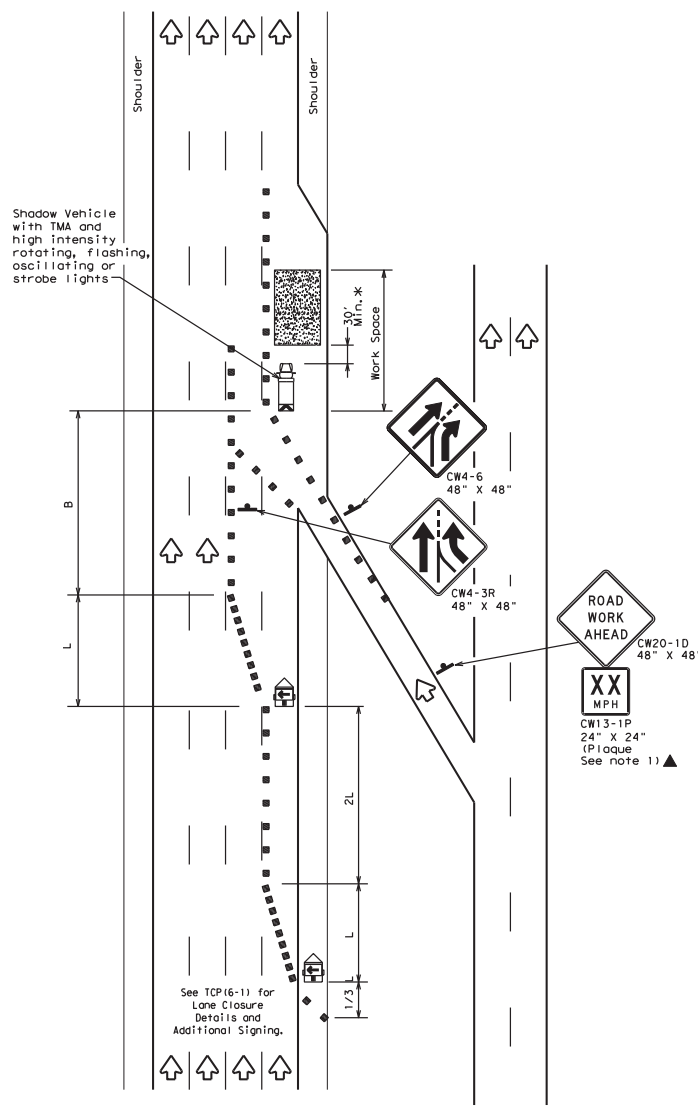

TCP (6-3a)  
**ENTRANCE RAMP OPEN**

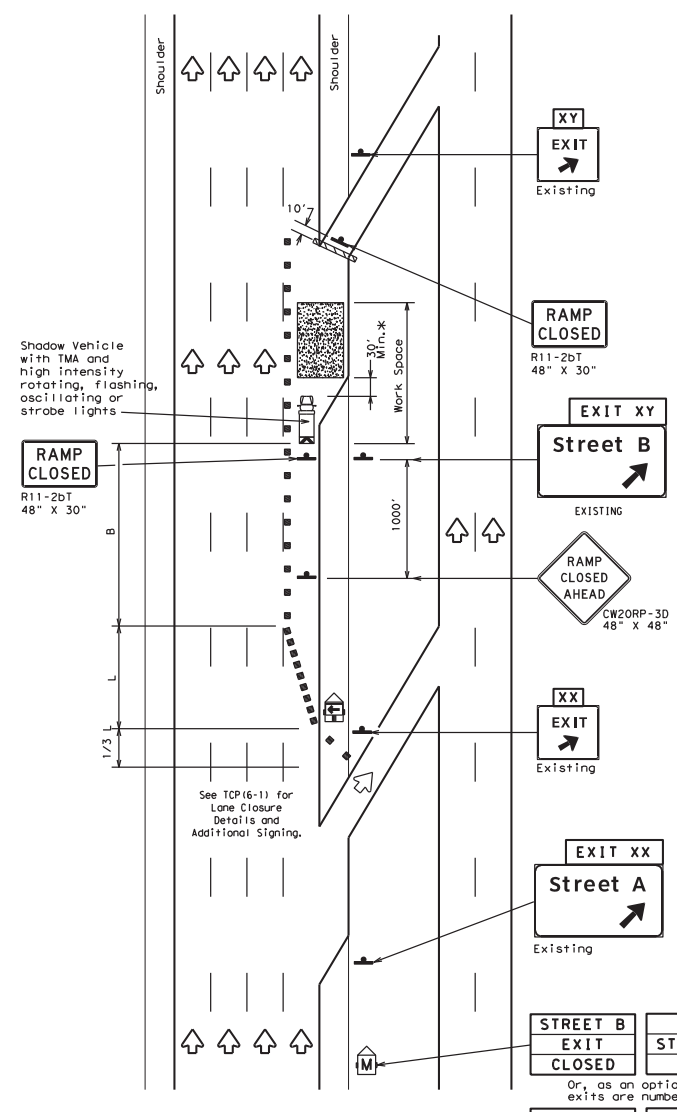

TCP (6-3b)  
**EXIT RAMP CLOSED**  
**TRAFFIC EXITS PRIOR TO CLOSED RAMP**

LEGEND			
	Type 3 Barricade		Channelizing Devices
	Heavy Work Vehicle		Truck Mounted Attenuator (TMA)
	Trailer Mounted Flashing Arrow Board		Portable Changeable Message Sign (PCMS)
	Sign		Traffic Flow
	Flag		Flagger

Posted Speed	Formula	Minimum Desirable Taper Lengths "L"			Suggested Maximum Spacing of Channelizing Devices		Suggested Longitudinal Buffer Space "B"
		10' Offset	11' Offset	12' Offset	On a Taper	On a Tangent	
45	L = WS	450'	495'	540'	45'	90'	195'
50		500'	550'	600'	50'	100'	240'
55		550'	605'	660'	55'	110'	295'
60		600'	660'	720'	60'	120'	350'
65		650'	715'	780'	65'	130'	410'
70		700'	770'	840'	70'	140'	475'
75		750'	825'	900'	75'	150'	540'
80		800'	880'	960'	80'	160'	615'

\*\* Taper lengths have been rounded off.  
 L=Length of Taper (FT) W=Width of Offset (FT) S=Posted Speed (MPH)

MOBILE	TYPICAL USAGE			
	SHORT DURATION	SHORT TERM STATIONARY	INTERMEDIATE TERM STATIONARY	LONG TERM STATIONARY
	✓	✓	✓	

GENERAL NOTES:  
 1. All traffic control devices illustrated are REQUIRED. Devices denoted with the triangle symbol may be omitted when stated elsewhere in the plans.

\*A shadow vehicle equipped with a Truck Mounted Attenuator is typically required. A shadow vehicle equipped with a TMA shall be used if it can be positioned 30' to 100' in advance of the area of crew exposure without adversely affecting the work performance.

Additional requirements for lane closures and advance signing shall be as shown on TCP (6-1) or as directed by the Engineer.

STREET B EXIT CLOSED	USE STREET A EXIT
EXIT XY CLOSED	USE EXIT XX

Or, as an option when exits are numbered

Place 1 mile (approx.) in advance of Street A exit.



**TRAFFIC CONTROL PLAN  
 WORK AREA BEYOND RAMP**

**TCP (6-3) - 12**

FILE: tcp6-3.dgn	DATE: TxDOT February 1994	CONT: 6379	SECT: 46	JOB: 001	SH: 320, ETC
1-97 8-98	4-98 8-12	DIST: WACO	COUNTY: FALLS	SHEET NO.: 40	

DISCLAIMER: This standard is governed by the "Texas Engineering Practice Act". No warranty of any kind is made by TxDOT for any purpose whatsoever. TxDOT assumes no responsibility for the conversion of this standard to other formats or for incorrect results or damages resulting from its use.

DATE: 3/23/2021 9:45:55 AM  
 FILE: T:\MACMAINT\1\RC-Contr\ccts\Bose\01\ure-P\mt\m\m\FY-2022\FALLS\CADD\SHEETS\STANDARDS\tcp6-4-12.dgn

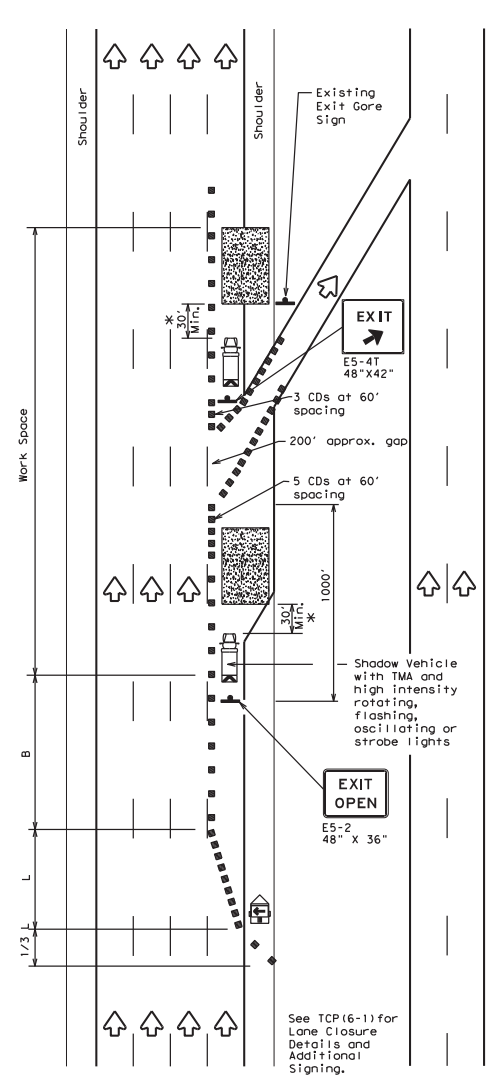
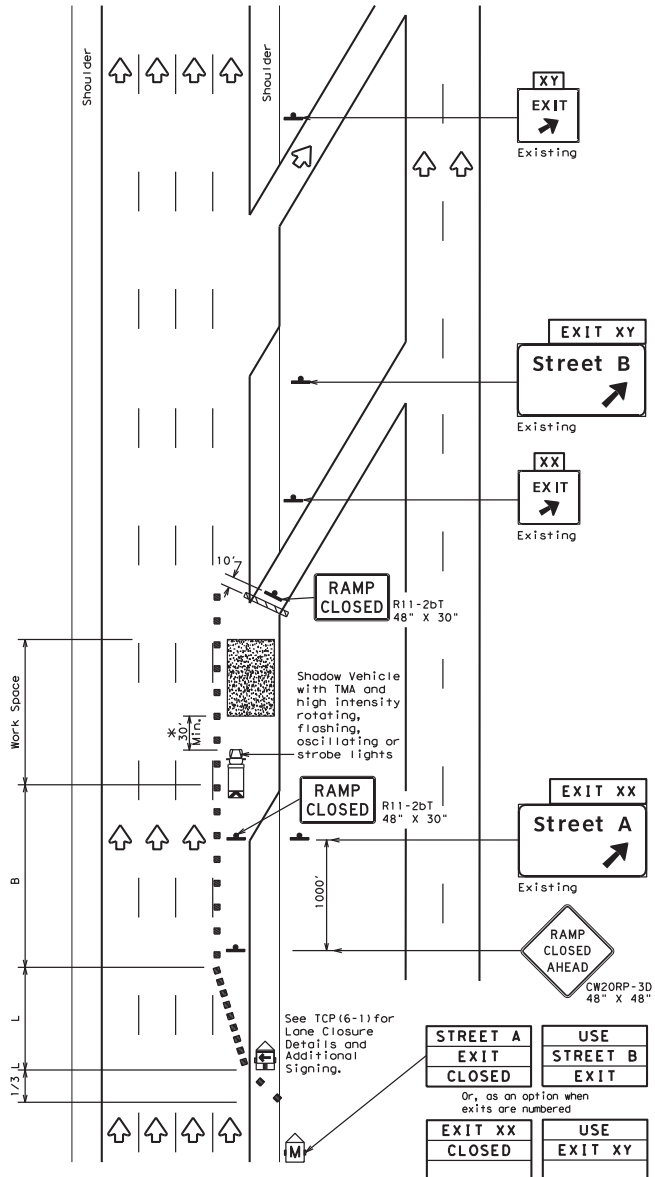

LEGEND			
	Type 3 Barricade		Channelizing Devices (CDs)
	Heavy Work Vehicle		Truck Mounted Attenuator (TMA)
	Trailer Mounted Flashing Arrow Board		Portable Changeable Message Sign (PCMS)
	Sign		Traffic Flow
	Flag		Flagger

Posted Speed	Formula	Minimum Desirable Taper Lengths "L"			Suggested Maximum Spacing of Channelizing Devices		Suggested Longitudinal Buffer Space "B"
		10' Offset	11' Offset	12' Offset	On a Taper	On a Tangent	
45	L = WS	450'	495'	540'	45'	90'	195'
50		500'	550'	600'	50'	100'	240'
55		550'	605'	660'	55'	110'	295'
60		600'	660'	720'	60'	120'	350'
65		650'	715'	780'	65'	130'	410'
70		700'	770'	840'	70'	140'	475'
75		750'	825'	900'	75'	150'	540'
80		800'	880'	960'	80'	160'	615'

\*\*Taper lengths have been rounded off.  
 L=Length of Taper (FT) W=Width of Offset (FT) S=Posted Speed (MPH)

TYPICAL USAGE				
MOBILE	SHORT DURATION	SHORT TERM STATIONARY	INTERMEDIATE TERM STATIONARY	LONG TERM STATIONARY
	✓	✓	✓	

- GENERAL NOTES**
- All traffic control devices illustrated are REQUIRED. Devices denoted with the triangle symbol may be omitted when stated elsewhere in the plans.
  - See BC Standards for sign details.

\*A shadow vehicle equipped with a Truck Mounted Attenuator is typically required. A shadow vehicle equipped with a TMA shall be used if it can be positioned 30' to 100' in advance of the area of crew exposure without adversely affecting the work performance.

Additional requirements for lane closures and advance signing shall be as shown on TCP (6-1) or as directed by the Engineer.



**TRAFFIC CONTROL PLAN**  
**WORK AREA AT EXIT RAMP**

**TCP (6-4) - 12**

FILE: tcp6-4.dgn	DATE: TxDOT	CHK: TxDOT	APP: TxDOT	CHK: TxDOT
© TxDOT February 1994	CONT: 6379	SECT: 46	JOB: 001	HIGHWAY: SH 320, ETC
1-97 8-98 4-98 8-12	DIST: WACO	COUNTY: FALLS	SHEET NO.: 41	

DISCLAIMER: This standard is governed by the "Texas Engineering Practice Act". No warranty of any kind is made by TxDOT for any purpose whatsoever. TxDOT assumes no responsibility for the conversion of this standard to other formats or for incorrect results or damages resulting from its use.

DATE: 3/23/2021 9:45:59 AM  
 FILE: T:\WACMAINT\WAC\_Contract\Bases\01\Ture\_Pvt\Tm\In\FY-2022\FALLS\CADD\SHEETS\STANDARDS\tcp6-5-12.dgn

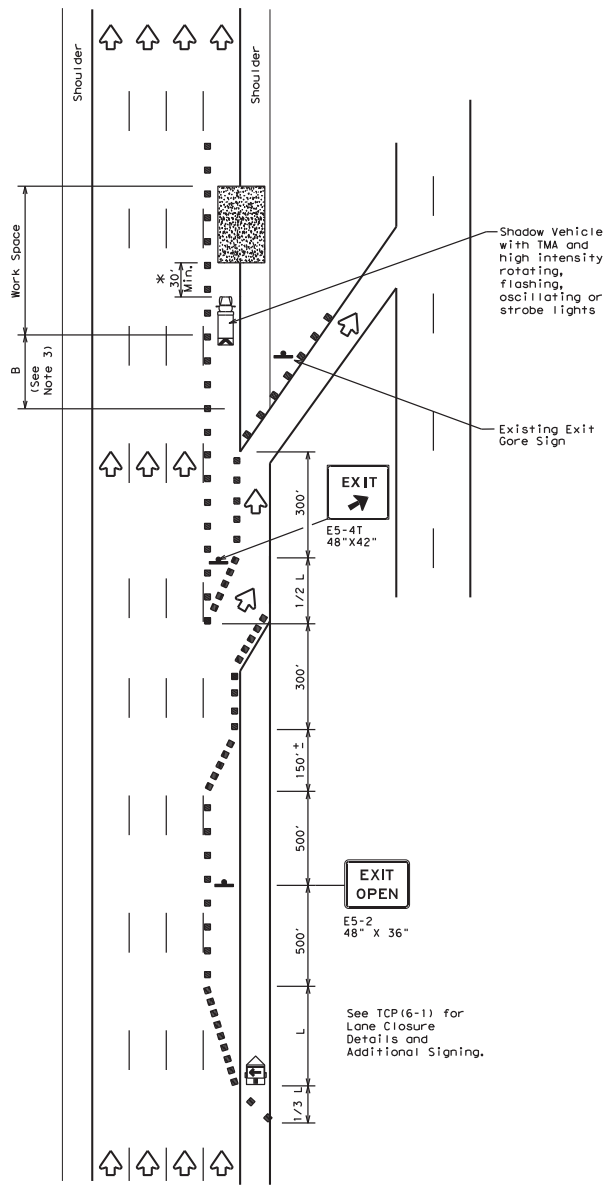

TCP (6-5a)  
**EXIT RAMP OPEN**

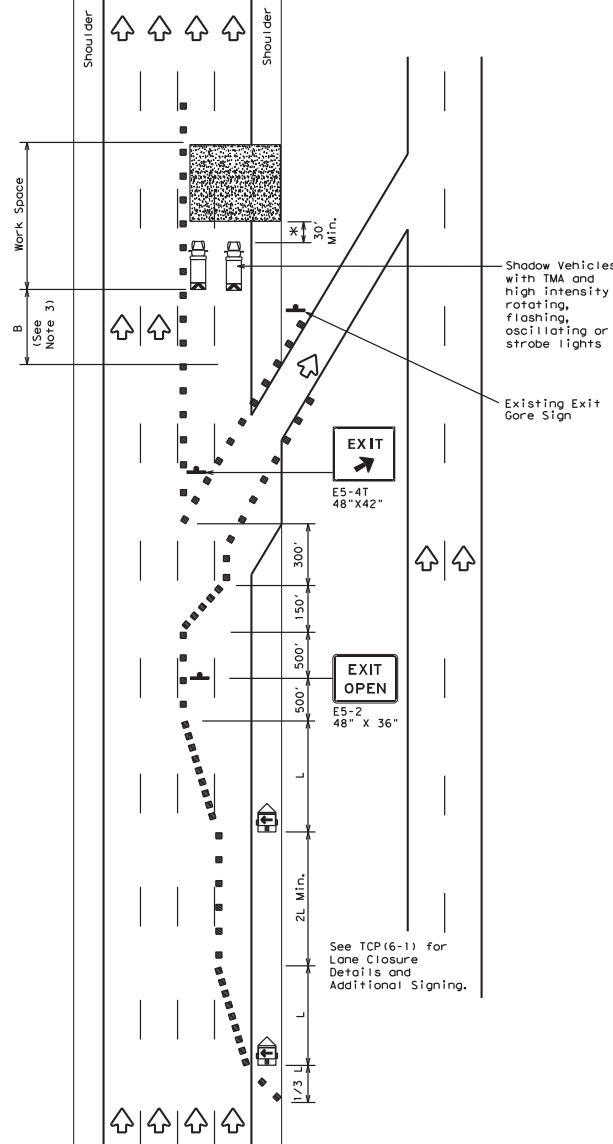

TCP (6-5b)  
**EXIT RAMP OPEN**  
**TWO LANE CLOSURE WITHIN**  
**1500' PAST EXIT RAMP**

LEGEND			
	Type 3 Barricade		Channelizing Devices
	Heavy Work Vehicle		Truck Mounted Attenuator (TMA)
	Trailer Mounted Flashing Arrow Board		Portable Changeable Message Sign (PCMS)
	Sign		Traffic Flow
	Flag		Flagger

Posted Speed	Formula	Minimum Desirable Taper Lengths "L"			Suggested Maximum Spacing of Channelizing Devices		Suggested Longitudinal Buffer Space "B"
		10' Offset	11' Offset	12' Offset	On a Taper	On a Tangent	
45	L = WS	450'	495'	540'	45'	90'	195'
50		500'	550'	600'	50'	100'	240'
55		550'	605'	660'	55'	110'	295'
60		600'	660'	720'	60'	120'	350'
65		650'	715'	780'	65'	130'	410'
70		700'	770'	840'	70'	140'	475'
75		750'	825'	900'	75'	150'	540'
80		800'	880'	960'	80'	160'	615'

\*\* Taper lengths have been rounded off.  
 L=Length of Taper (FT) W=Width of Offset (FT) S=Posted Speed (MPH)

TYPICAL USAGE				
MOBILE	SHORT DURATION	SHORT TERM STATIONARY	INTERMEDIATE TERM STATIONARY	LONG TERM STATIONARY
	✓	✓	✓	

**GENERAL NOTES**

- All traffic control devices illustrated are REQUIRED. Devices denoted with the triangle symbol may be omitted when stated elsewhere in the plans.
- See BC standards for sign details.
- If adequate longitudinal buffer length "B" does not exist between the work space and the exit ramp, consideration should be given to closing the ramp.

\*A shadow vehicle equipped with a Truck Mounted Attenuator is typically required. A shadow vehicle equipped with a TMA shall be used if it can be positioned 30' to 100' in advance of the area of crew exposure without adversely affecting the work performance.

Additional requirements for lane closures and advance signing shall be as shown on TCP (6-1) or as directed by the Engineer.



**TRAFFIC CONTROL PLAN**  
**WORK AREA BEYOND EXIT RAMP**

**TCP (6-5) - 12**

FILE: tcp6-5.dgn	DN: TxDOT	CR: TxDOT	DR: TxDOT	CK: TxDOT
© TxDOT February 1998	CONT	SECT	JOB	HIGHWAY
REVISIONS	6379	46	001	SH 320, ETC
1-97 8-98	DIST	COUNTY	SHEET NO.	
4-98 8-12	WACO	FALLS	42	



DISCLAIMER: This standard is governed by the "Texas Engineering Practice Act". No warranty of any kind is made by TxDOT for any purpose whatsoever. TxDOT assumes no responsibility for the conversion of this standard to other formats or for incorrect results or damages resulting from its use.

DATE: 3/23/2021 9:46:05 AM  
FILE: T:\WACMAINT\WAC\_Contractors\Base\01\ure\_Pvm\Main\FY-2022\FALLS\GADD\SHEETS\STANDARDS\tcp6-9-14.dgn

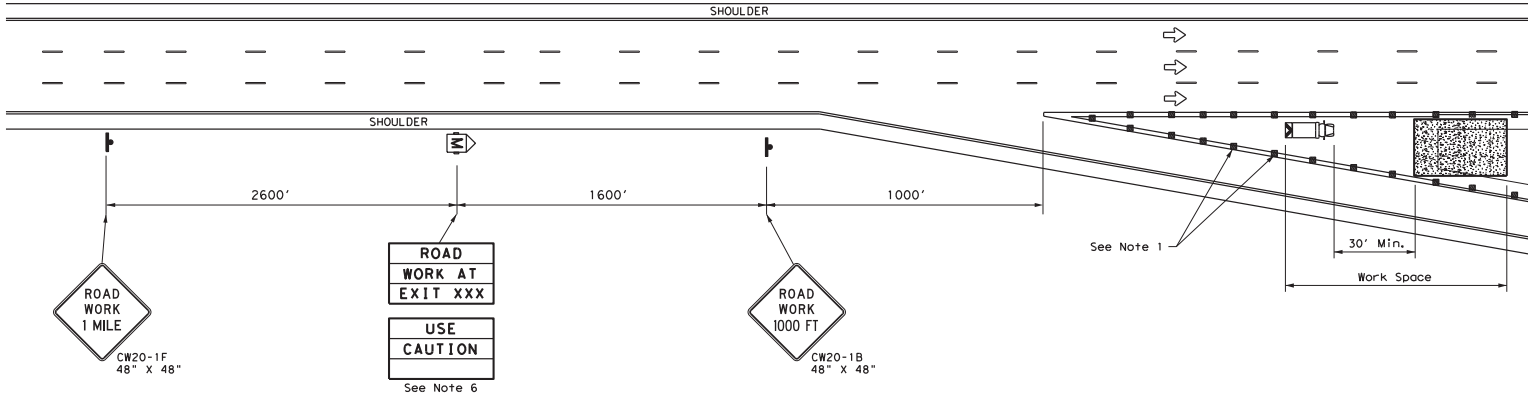

TCP (6-9a)

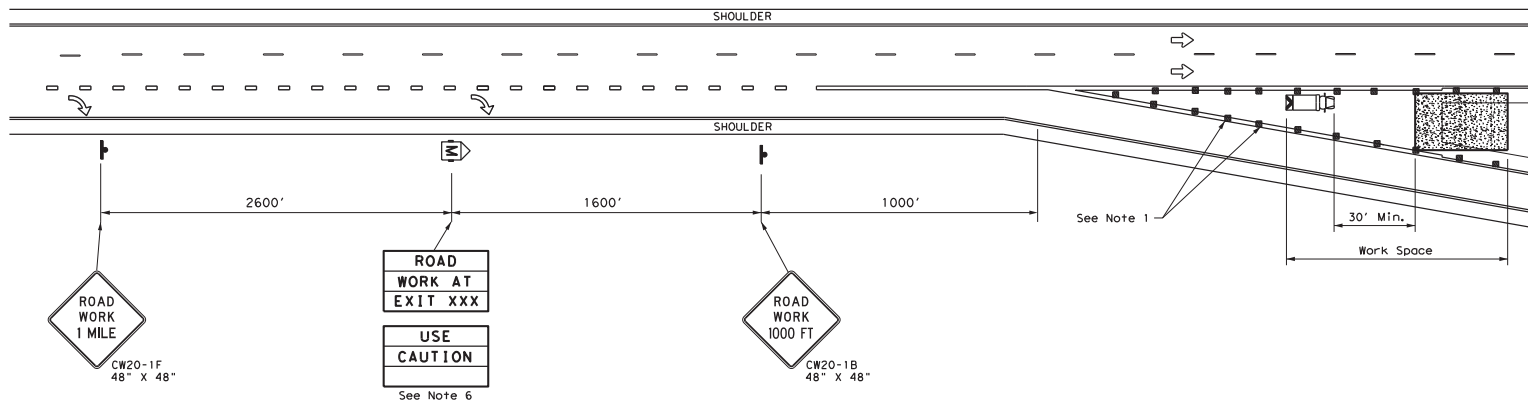

TCP (6-9b)

LEGEND			
	Type 3 Barricade		Channelizing Devices (CDs)
	Heavy Work Vehicle		Truck Mounted Attenuator (TMA)
	Trailer Mounted Flashing Arrow Board		Portable Changeable Message Sign (PCMS)
	Sign		Traffic Flow
	Flag		Flagger

Posted Speed	Formula	Minimum Desirable Taper Lengths "L" *X			Suggested Maximum Spacing of Channelizing Devices		Suggested Longitudinal Buffer Space "B"
		10' Offset	12' Offset	12' Offset	On a Taper	On a Tangent	
45	L = WS	450'	495'	540'	45'	90'	195'
50		500'	550'	600'	50'	100'	240'
55		550'	605'	660'	55'	110'	295'
60		600'	660'	720'	60'	120'	350'
65		650'	715'	780'	65'	130'	410'
70		700'	770'	840'	70'	140'	475'
75		750'	825'	900'	75'	150'	540'
80		800'	880'	960'	80'	160'	615'

\*\* Taper lengths have been rounded off.  
L=Length of Taper (FT) W=Width of Offset (FT)  
S=Posted Speed (MPH)

TYPICAL USAGE				
MOBILE	SHORT DURATION	SHORT TERM STATIONARY	INTERMEDIATE TERM STATIONARY	LONG TERM STATIONARY
	✓	✓		

- GENERAL NOTES**
- Place channelizing devices in the gore at 20' spacing.
  - See the Standard Highway Sign Design for Texas (SHSD) for sign details.
  - The PCMS may be omitted when a permanent DMS sign is available in an appropriate location to display a similar message as called for on the PCMS.
  - When it is determined that a through lane should be closed in addition to the exit ramp, refer to TCP(6-4) and TCP(6-8) for traffic control details.
  - Truck mounted attenuators are required.
  - The PCMS may be omitted if replaced with a "ROAD WORK 1/2 MILE" (CW20-1E).
  - Roadway ADT should be less than 10,000.



**WORK IN EXIT GORE FOR ADT LESS THAN 10,000**

**TCP (6-9) - 14**

FILE: tcp6-9.dgn	DATE: TxDOT	DATE: TxDOT	DATE: TxDOT	DATE: TxDOT
© TxDOT February 2014	CONT SECT	JOB	HIGHWAY	
REVISIONS	6379	46	001	SH 320, ETC
	DIST	COUNTY		SHEET NO.
	WACO	FALLS		44



DISCLAIMER: This standard is governed by the "Texas Engineering Practice Act". No warranty of any kind is made by TxDOT for any purpose whatsoever. TxDOT assumes no responsibility for the conversion of this standard to other formats or for incorrect results or damages resulting from its use.

DATE: 3/23/2021 9:46:07 AM  
FILE: T:\MCM\INT\...RMC\_Contractors\Base\01\ure\_P\m\m\m\m\...STANDARDS\Tcsp7-1-13.dgn

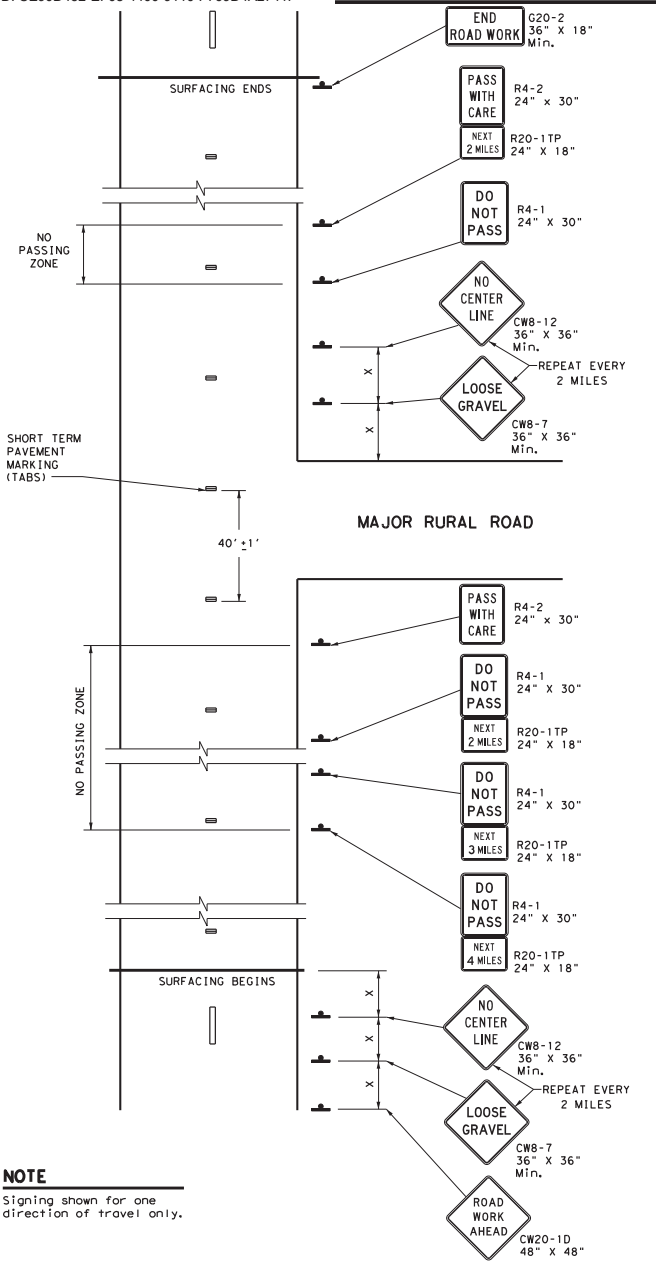

**NOTE**  
Signing shown for one direction of travel only.

**NO PASSING ZONES ON TWO-LANE TWO-WAY ROADS**

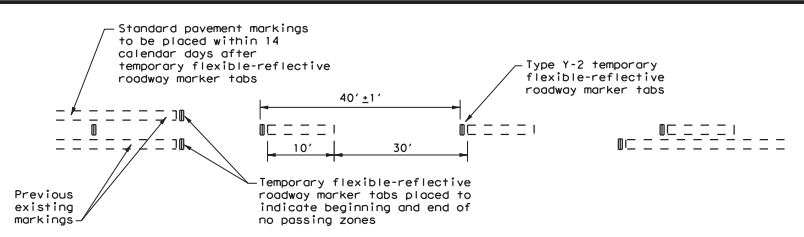

**TABS ON CENTERLINES OF TWO-LANE TWO-WAY ROADS**  
For seal coat, micro-surface or similar operations

**"DO NOT PASS" SIGN (R4-1) and NO-PASSING ZONES**

- A. Prior to the beginning of construction, all currently striped no-passing zones shall be signed with the DO NOT PASS (R4-1) signs and PASS WITH CARE (R4-2) signs placed at the beginning and end of each zone for each direction of travel except as otherwise provided herein. Signs marking these individual no-passing zones need not be covered prior to construction if the signs supplement the existing pavement markings.
- B. At the discretion of the Engineer, in areas of numerous no-passing zones, several zones may be combined as a single zone. If passing is to be prohibited over one or more lengthy sections, a DO NOT PASS sign and a NEXT XX MILES plaque may be used at the beginning of such zones. The DO NOT PASS sign and the NEXT XX MILES plaque should be repeated every mile to the end of the no-passing zone. In areas where there is considerable distance between no-passing zones, the end of the no-passing zone may be signed with a PASS WITH CARE sign and a NEXT XX MILES plaque.
- C. Depending on traffic volumes and length of sections, it may be desirable to prohibit passing throughout the project to prevent damage to windshield and lights. The DO NOT PASS sign and NEXT XX MILES plaque should be used and repeated as often as necessary for this purpose. Where several existing zones are to be combined into one individual no-passing zone, the sign at the beginning of the zone should be covered until the surfacing operation has passed this location so as not to have the DO NOT PASS sign conflict with the existing pavement markings. Also, unless one day operation completes the entire length of such combined zones, appropriate DO NOT PASS and PASS WITH CARE signs should be placed at the beginning and end of the no-passing zones where the surfacing operation has stopped for the day.
- D. R4-1 and R4-2 are to remain in place until standard pavement markings are installed.

**"NO CENTER LINE" SIGN (CW8-12)**

- A. Center line markings are yellow pavement markings that delineate the separation of travel lanes that have opposite directions of travel on a roadway. Divided highways do not typically have center line markings.
- B. At the time construction activity obliterates the existing center line markings (low volume roads may not have an existing centerline), a NO CENTER LINE (CW8-12) sign should be erected at the beginning of the work area, at approximately 2 mile intervals within the work area, beyond major intersections and other locations deemed necessary by the Engineer.
- C. The NO CENTER LINE signs are to remain in place until standard pavement markings are installed.

**"LOOSE GRAVEL" SIGN (CW8-7)**

- A. When construction begins, a LOOSE GRAVEL (CW8-7) sign should be erected at each end of the work area and repeated at intervals of approximately 2 miles in rural areas and closer in urban areas.
- B. The LOOSE GRAVEL signs are to remain in place until the condition no longer exists.

**PAVEMENT MARKINGS**

- A. Temporary markings for surfacing projects shall be Temporary Flexible-reflective Roadway Marker Tabs unless otherwise approved by the Engineer. Tabs are to be installed to provide true alignment for striping crews or as directed by the Engineer. Tabs will be placed at the spacing indicated. Tabs should be applied to the pavement no more than two (2) days before the surfacing is applied. After the surfacing is rolled and swept, the cover over the reflective strip shall be removed.
- B. Tabs shall not be used to simulate edge lines.
- C. Tab placement for overlay/inlay operations shall be as shown on the W2(STPM) standard sheet.

**COORDINATION OF SIGN LOCATIONS**

- A. The location of warning signs at the beginning and end of a work area are to be coordinated with other signing typically shown on the Barricade and Construction Standards for project limits to ensure adequate sign spacing.
- B. Where possible the ROAD WORK AHEAD (CW20-1D), LOOSE GRAVEL (CW8-7), and NO CENTER LINE (CW8-12) signs should be placed in the sequence shown following the OBEY WARNING SIGNS STATE LAW (R20-3T) and the TRAFFIC FINES DOUBLE (R20-5T) sign, and one "X" sign spacing prior to the CONTRACTOR (G20-6T) sign typically located at or near the limits of surfacing. LOOSE GRAVEL and NO CENTER LINE signs will then be repeated as described above.

Posted Speed * *	Minimum Sign Spacing "x" Distance
30	120'
35	160'
40	240'
45	320'
50	400'
55	500'
60	600'
65	700'
70	800'
75	900'

\* Conventional Roads Only

TYPICAL USAGE				
MOBILE	SHORT DURATION	SHORT TERM STATIONARY	INTERMEDIATE TERM STATIONARY	LONG TERM STATIONARY
			✓	✓

**GENERAL NOTES**

1. The traffic control devices detailed on this sheet will be furnished and erected as directed by the Engineer on sections of roadway where tabs must be placed prior to the surfacing operation which will cover or obliterate the existing pavement markings.
2. The devices shown on this sheet are to be used to supplement those required by the BC Standards or others required elsewhere in the plans.
3. Signs shall be erected as detailed on the BC Standards or the Compliant Work Zone Traffic Control Devices List (CWZTCD) on supports approved for Long-Term / Intermediate-Term Work Zone Sign Supports.
4. When surfacing operations take place on divided highways, freeways or expressways, the size of diamond shaped construction warning signs shall be 48" x 48".
5. Signs on divided highways, freeways and expressways will be placed on both right and left sides of the roadway based on roadway conditions as directed by the Engineer.

Texas Department of Transportation  
Traffic Operations Division  
Standard

**TRAFFIC CONTROL DETAILS FOR SURFACING OPERATIONS**

**TCP (7-1) - 13**

FILE: tcp7-1.dgn	DN: TxDOT	CR: TxDOT	DR: TxDOT	EX: TxDOT
© TxDOT March 1991	CONF SECT	JOB	HIGHWAY	
4-92 4-98 REVISIONS	6379 46	001	SH 320, ETC	
1-97 7-13	DIST	COUNTY	SHEET NO.	
	WACO	FALLS	45	

210

DISCLAIMER: of this standard is governed by the "Texas Engineering Practice Act". No warranty of any kind is made by TxDOT for any purpose whatsoever. TxDOT assumes no responsibility for the conversion of this standard to other formats or for incorrect results or damages resulting from its use.

DATE: 3/23/2021  
FILE: T:\MACMAINT\1-RMC-Contractors\Boseff\1-FY-2022\FALLS\KADDS\SHEETS\STANDARDS\WZTD-17.dgn

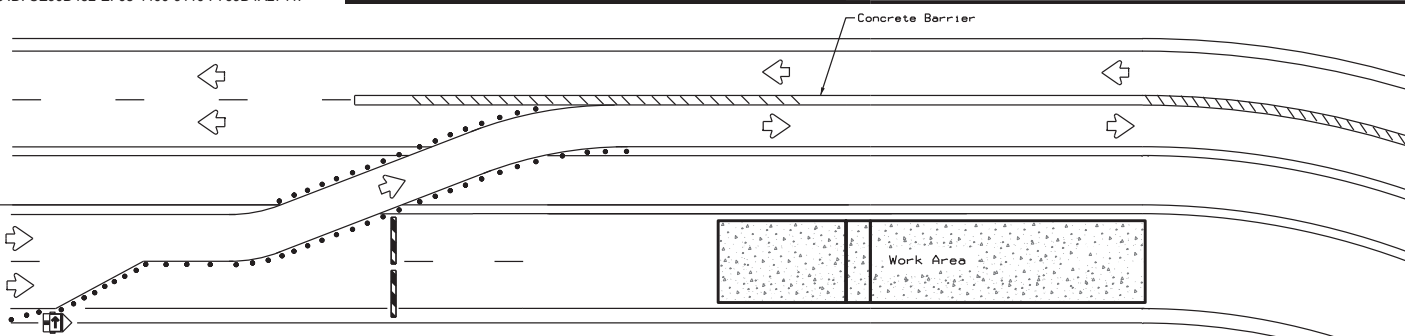

LEGEND	
	Type 3 Barricade
	Channelizing Devices
	Trailer Mounted Flashing Arrow Board
	Sign
	Safety glare screen

DEPARTMENTAL MATERIAL SPECIFICATIONS	
SIGN FACE MATERIALS	DMS-8300
DELINEATORS AND OBJECT MARKERS	DMS-8600
MODULAR GLARE SCREENS FOR HEADLIGHT BARRIER	DMS-8610

Only pre-qualified products shall be used. A copy of the Compliant Work Zone Traffic Control Devices List\* (CWZCD) describes pre-qualified products and their sources and may be found at the following web address:

<http://www.txdot.gov/business/resources/producer-list.html>

**NOTES:**

- Length of Safety Glare screen will be specified elsewhere in the plans.
- The cumulative nominal length of the modular safety glare screen units shall equal the length of the individual sections of temporary concrete traffic barrier on which they are installed so the joint between barrier sections will not be spanned by any one safety glare screen unit.
- Screen Panel/blades will be designed such that reflective sheeting conforming with Departmental Material Specification DMS-8300, Sign Face Materials, Type B or C Yellow, minimum size of 2 inches by 12 inches can be attached to the edge of the panel/blade. The sheeting shall be attached to one glare screen panel/blade per section of concrete barrier not to exceed a spacing of 30 feet. Barrier reflectors are not necessary when panel/blades are installed with reflective sheeting as described.
- Payment for these devices will be under statewide Special Specification "Modular Glare Screens for Headlight Barrier."
- This detail is only intended to show types of locations where Glare Screens would be appropriate. Required signing and other devices shall be as shown elsewhere in the plans.

**BARRIER DELINEATION WITH MODULAR GLARE SCREENS**

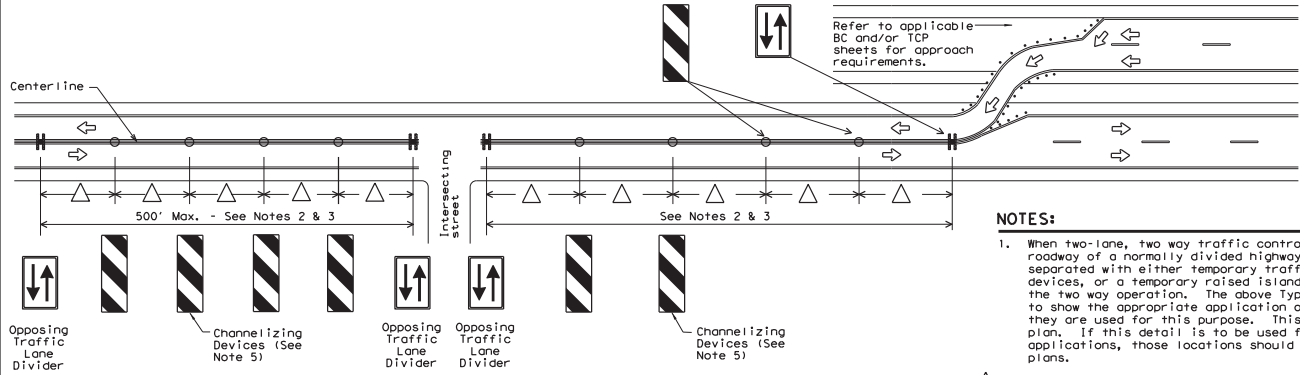

**NOTES:**

- When two-lane, two way traffic control must be maintained on one roadway of a normally divided highway, opposing traffic shall be separated with either temporary traffic barriers, channelizing devices, or a temporary raised island throughout the length of the two way operation. The above Typical Application is intended to show the appropriate application of channelizing devices when they are used for this purpose. This is not a traffic control plan. If this detail is to be used for other types of roads or applications, those locations should be stated elsewhere in the plans.
- Space devices according to the Tangent Spacing shown on the Device Spacing table on BC(9) but not exceeding 100'.
- Every fifth device should be an OTLD except when spaced closer to accommodate an intersection. An OTLD should be the first device on each side of intersecting streets or roads.
- Locations where surface mount bases with adhesives or self-righting devices will be required in order to maintain them in their proper position should be noted elsewhere in the plans.
- Channelizing devices are to be vertical panels, 42" cones or tubular markers that are at least 36" tall. Tubular markers used to separate traffic should have a rubber base weighing at least 30 pounds. Tubular markers that are 42" tall or more shall have four bands of reflective material as detailed for 42" cones on BC(10). Tubular markers less than 42" but at least 36" tall shall have three bands of 3" wide white reflective material spaced 2' apart. Reflective material shall meet DMS-8300, Type A.

**VERTICAL PANELS & OPPOSING TRAFFIC LANE DIVIDERS (OTLD) SEPARATING TWO-WAY TRAFFIC ON NORMALLY DIVIDED HIGHWAYS**

Traffic Operations Division Standard

**TRAFFIC CONTROL PLAN**  
**TYPICAL DETAILS**

**WZ (TD) - 17**

FILE: wzd-17.dgn	DN: TxDOT	CR: TxDOT	DR: TxDOT	CK: TxDOT
© TxDOT February 1998	CONT SECT	JOB	HIGHWAY	
REVISIONS	6379	46	001	SH 320, ETC
4-98	DIST	COUNTY		SHEET NO.
3-03	WACO		FALLS	46
7-13				

DISCLAIMER: This standard is governed by the "Texas Engineering Practice Act". No warranty of any kind is made by TxDOT for any purpose whatsoever. TxDOT assumes no responsibility for the conversion of this standard to other formats or for incorrect results or damages resulting from its use.

DATE: 3/23/2021 9:46:13 AM  
 FILE: \\F:\MCM\INT\TWC\Contractors\Bases\G1\Ture\_Pvm\Mat\m\FY-2022\FALLS\CD\SDS\SHEETS\STANDARDS\wzstpm-13.dgn

### WORK ZONE SHORT TERM PAVEMENT MARKINGS DETAILS

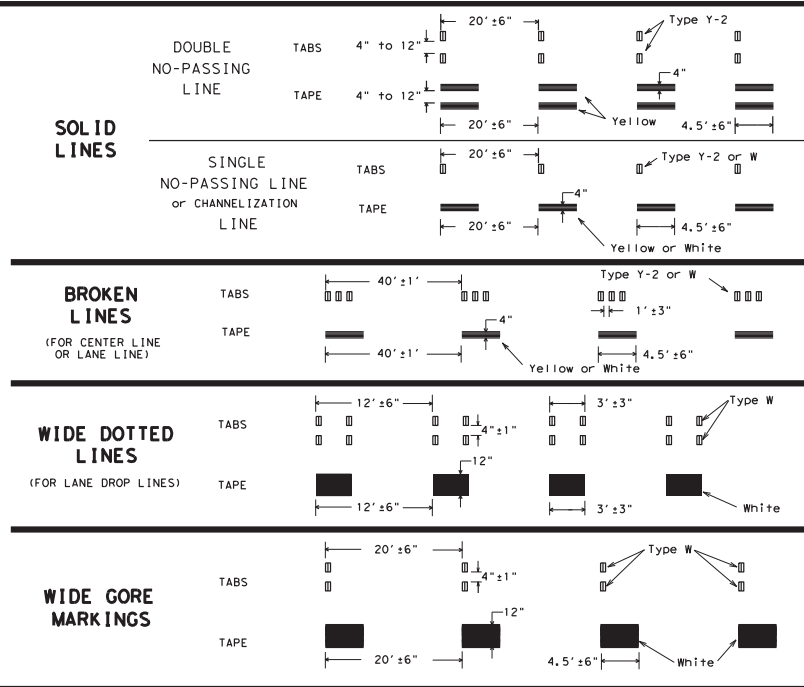

- NOTES:**
- Short term pavement markings may be prefabricated markings (stick down tape) or temporary flexible-reflective roadway marker tabs unless otherwise specified elsewhere in plans.
  - Short term pavement markings shall NOT be used to simulate edge lines.
  - Dimensions indicated on this sheet are typical and approximate. Variations in size and height may occur between markers or devices made by manufacturers, by as much as 1/4 inch, unless otherwise noted.
  - Temporary flexible-reflective roadway marker tabs will require normal maintenance replacement when used on roadways with an ADT per lane of up to 7500 vehicles with no more than 10% truck mix. When roadways exceed these values, additional maintenance replacement of devices should be planned.
  - No segment of roadway open to traffic shall remain without permanent pavement markings for a period greater than 14 calendar days. The Contractor will be responsible for maintaining short term pavement markings until permanent pavement markings are in place. When the Contractor is responsible for placement of permanent pavement markings, no segment of roadway shall remain without permanent pavement markings for a period greater than 14 calendar days unless weather conditions prohibit placement. Permanent pavement markings shall be placed as soon as weather permits.
  - For two lane, two-way roadways, DO NOT PASS signs shall be erected to mark the beginning of sections where passing is prohibited and PASS WITH CARE signs shall be erected to mark the beginning of sections where passing is permitted. Signs shall be in accordance with the "Texas Manual on Uniform Traffic Control Devices" (TMUTCD) and may be used to indicate the limits of no-passing zones for up to 14 calendar days. Permanent pavement markings should then be placed.
  - For low volume two lane, two-way roadways of 4000 ADT or less, no-passing lines may be omitted when approved by the Engineer. DO NOT PASS and PASS WITH CARE signs shall be erected (see note 6).
  - For exit gores where a lane is being dropped place wide gore markings or retroreflective channelizing devices to guide motorist through the exit. If channelizing devices are to be used it should be noted elsewhere in the plans. One piece cones are not allowed for this purpose.

- TEMPORARY FLEXIBLE, REFLECTIVE ROADWAY MARKER TABS (TABS)**
- Temporary flexible-reflective roadway marker tabs detailed on this sheet will be designated Type Y-2 (two amber reflective surfaces with yellow body); Type Y (one amber reflective surface with yellow body); and Type W (one white or silver reflective surface with white body). Additional details may be found on BC(11).
  - Tabs shall meet requirements of Departmental Material Specification DMS-8242.
  - When dry, tabs shall be visible for a minimum distance of 200 feet during normal daylight hours and when illuminated by automobile low-beam head light at night, unless sight distance is restricted by roadway geometrics.
  - No two consecutive tabs nor four tabs per 1000 feet of line shall be missing or fail to meet the visual performance requirements of Note 3.

### WORK ZONE SHORT TERM PAVEMENT MARKINGS PATTERNS

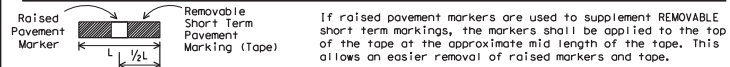
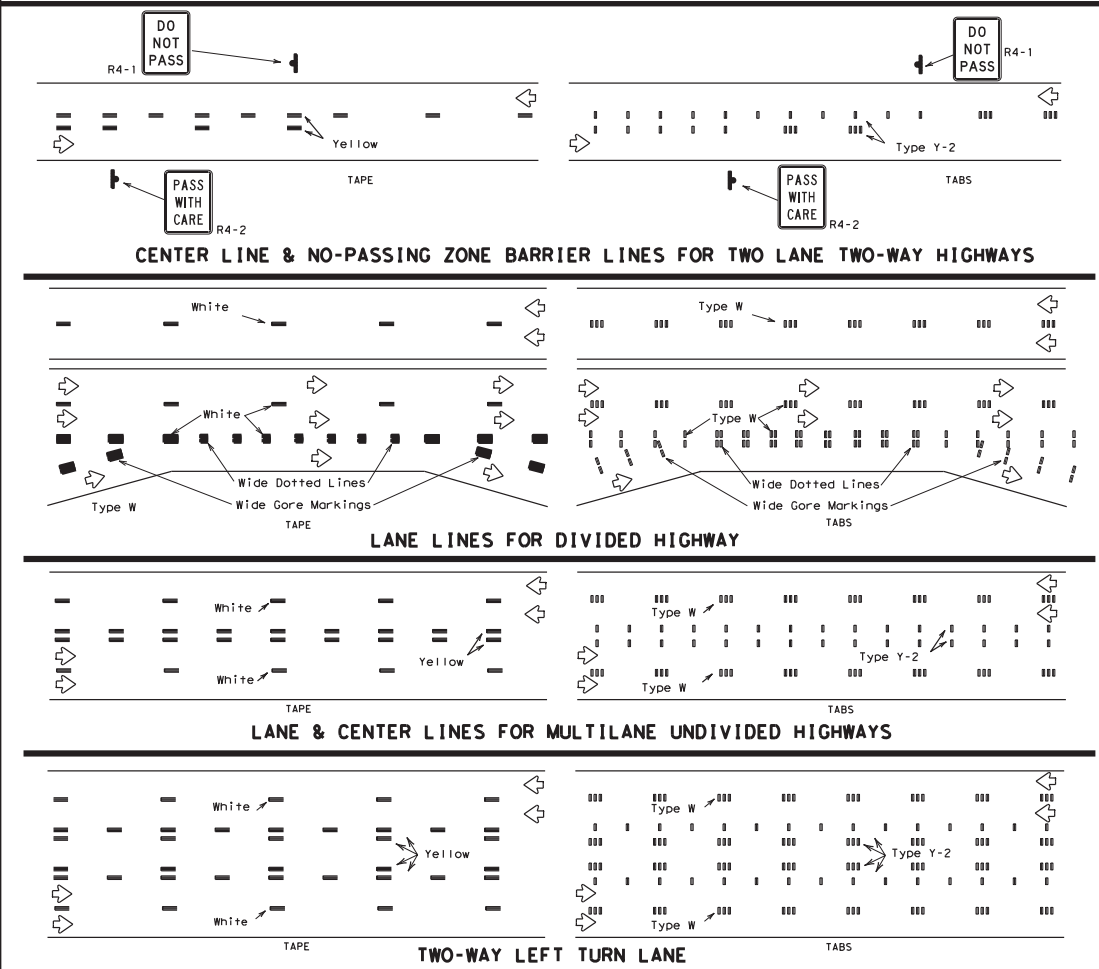

- PREFABRICATED PAVEMENT MARKINGS**
- Temporary Removable Prefabricated Pavement Markings shall meet the requirements of DMS-8241.
  - Non-removable Prefabricated Pavement Markings shall meet the requirements of either DMS-8240 "Permanent Prefabricated Pavement Markings" or DMS-8243 "Temporary Construction-Grade Prefabricated Pavement Markings."
- RAISED PAVEMENT MARKERS**
- All raised pavement markers used for work zone markings shall meet the requirements of Item 672, "RAISED PAVEMENT MARKERS" and DMS-4200.
- DEPARTMENTAL MATERIAL SPECIFICATIONS (DMS) & MATERIAL PRODUCER LISTS (MPL)**
- DMSs referenced above can be found along with embedded links to their respective MPLs at the following website:  
[http://www.txdot.gov/business/contractors\\_consultants/material\\_specifications/default.htm](http://www.txdot.gov/business/contractors_consultants/material_specifications/default.htm)

Texas Department of Transportation  
 Traffic Operations Division Standard

**WORK ZONE SHORT TERM PAVEMENT MARKINGS**

**WZ (STPM) - 13**

FILE:	wzstpm-13.dgn	DN:	TxDOT	CR:	TxDOT	DN:	TxDOT	CR:	TxDOT
© TxDOT	Apr 11 1992	CONT	SECT	JOB	SH	320, ETC			
1-97	REVISIONS	6379	46	001					
3-03		DIST	COUNTY	SHEET NO.					
7-13		WACO	FALLS	47					

DISCLAIMER: This standard is governed by the "Texas Engineering Practice Act". No warranty of any kind is made by TxDOT for any purpose whatsoever. TxDOT assumes no responsibility for the conversion of this standard to other formats or for incorrect results or damages resulting from its use.

DATE: 3/23/2021 9:46:16 AM  
FILE: T:\MACMINTY\TMC\_Contractors\Base\01\ure\_Pvm\Main\FY-2022\FALLS\CADD\SHEETS\STANDARDS\WZUL-13.dgn

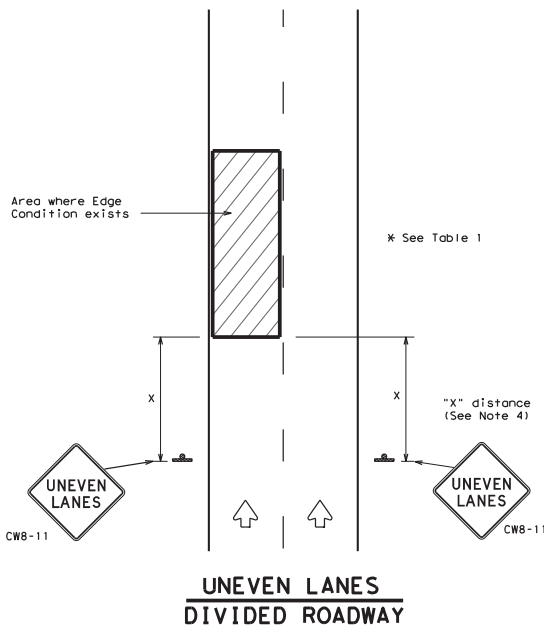
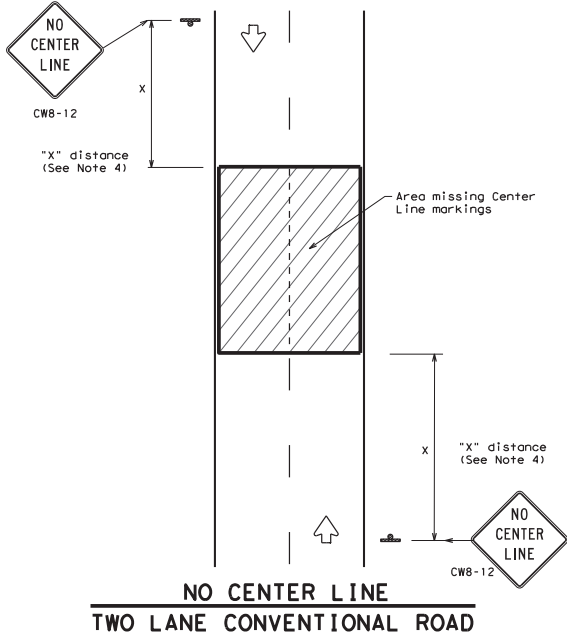
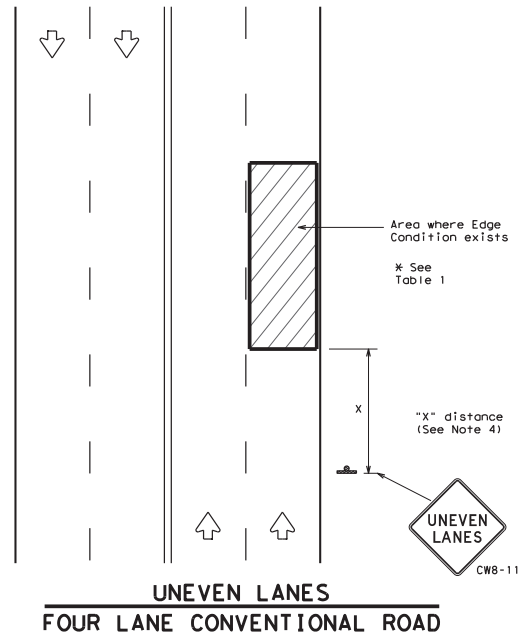
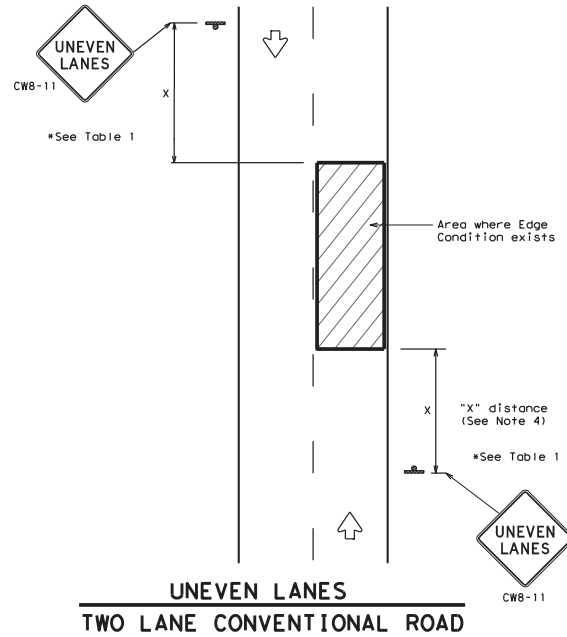

DEPARTMENTAL MATERIAL SPECIFICATIONS			
PERMANENT PREFABRICATED PAVEMENT MARKINGS			DMS-8240
TEMPORARY (REMOVABLE) PREFABRICATED PAVEMENT MARKINGS			DMS-8241
SIGN FACE MATERIALS			DMS-8300
COLOR	USAGE	SHEETING MATERIAL	
ORANGE	BACKGROUND	TYPE B <sub>PL</sub> OR TYPE C <sub>PL</sub> SHEETING	
BLACK	LEGEND & BORDERS	ACRYLIC NON-REFLECTIVE SHEETING	

- GENERAL NOTES**
1. If spalling or holes occur, ROUGH ROAD (CW8-8) signs should be placed in advance of the condition and be repeated every two miles where the condition persists.
  2. UNEVEN LANES (CW8-11) signs shall be installed in advance of the condition and repeated every mile. Signs installed along the uneven lane condition may be supplemented with the NEXT XX MILES (CW7-3aP) plaque or Advisory Speed (CW13-1P) plaque.
  3. NO CENTER LINE (CW8-12) signs and temporary pavement markings as per the WZ(STPM) standard shall be installed if yellow centerlines separating two way traffic are obscured or obliterated. Repeat NO CENTER LINE signs every two miles where the center line markings are not in place. The signs and markings shall remain in place until permanent pavement markings are installed.
  4. Signs shall be spaced at the distances recommended as per BC standards.
  5. Additional signs may be required as directed by the Engineer. Signs shall remain in place until final surface is applied. Signs shall be considered subsidiary to Item 502 "BARRICADES, SIGNS AND TRAFFIC HANDLING."
  6. Signs shall be fabricated and mounted on supports as shown on the BC standards and/or listed on the "Compliant Work Zone Traffic Control Devices" list.
  7. Short term markings shall not be used to simulate edge lines.
  8. All signs shall be constructed in accordance with the details found in the "Standard Highway Sign Designs for Texas," latest edition.

TABLE 1		
Edge Condition	Edge Height (D)	* Warning Devices
①	Less than or equal to: 1/4" (maximum-planing) 1/2" (typical-overlay)	Sign: CW8-11
②	Less than or equal to 3"	Sign: CW8-11
③	Distance "D" may be a maximum of 3" if uneven lanes with edge condition 2 or 3 are open to traffic after work operations cease. Uneven lanes should not be open to traffic when "D" is greater than 3".	

**TRAFFIC CONTROL DURING PLANING, OVERLAY AND LEVELING OPERATIONS ARE SHOWN ELSEWHERE IN THE PLANS.**

MINIMUM WARNING SIGN SIZE		
Conventional roads	36" x 36"	
Freeways/expressways, divided roadways	48" x 48"	

**Texas Department of Transportation**

**TRAFFIC OPERATIONS DIVISION**

**STANDARD**

**SIGNING FOR UNEVEN LANES**

**WZ (UL) - 13**

FILE: WZUL-13.dgn	DN: TxDOT	CR: TxDOT	DR: TxDOT	EX: TxDOT
© TxDOT April 1992	CONT SECT	JOB	HIGHWAY	
REVISIONS	6379	46	001	SH 320, ETC
8-95 2-98 7-13	DIST	COUNTY	SHEET NO.	
1-97 3-03	WACO	FALLS	48	

DISCLAIMER: This standard is governed by the "Texas Engineering Practice Act". No warranty of any kind is made by TxDOT for any purpose whatsoever. TxDOT assumes no responsibility for the conversion of this standard to other formats or for incorrect results or damages resulting from its use.

DATE: 3/23/2021 9:46:19 AM  
 FILE: T:\MACMAINT\T-RMC-Contractors\Base\011ure\_Pvm\Main\FY-2022\FALLS\CADD\SHEETS\STANDARDS\wzrs-16.dgn

Warning sign and rumble strip sequence in opposite direction is same as below

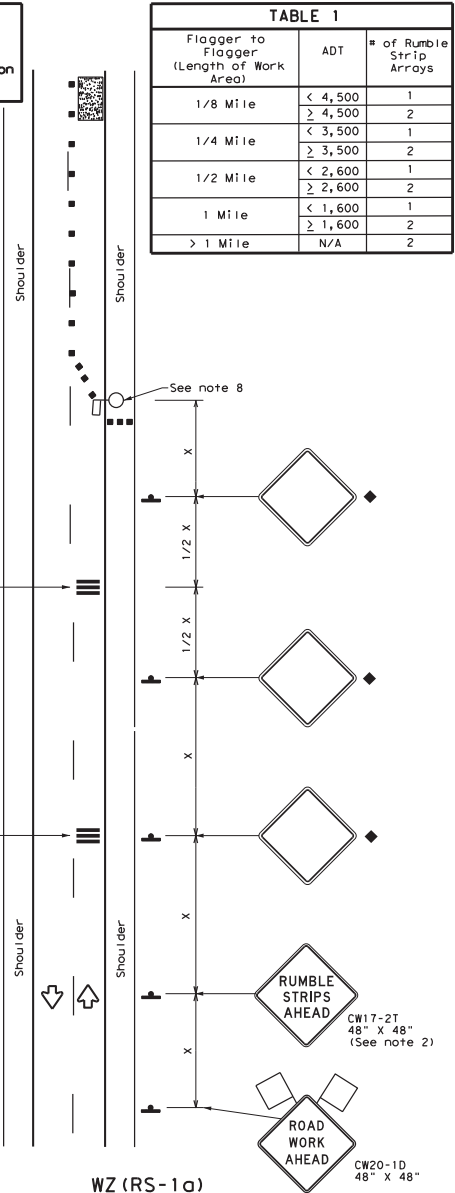

WZ (RS-1a)  
75 mph or Less  
**RUMBLE STRIPS ON ONE-LANE TWO-WAY APPLICATION**

Flagger to Flagger (Length of Work Area)	ADT	# of Rumble Strip Arrays
1/8 Mile	< 4,500	1
	> 4,500	2
1/4 Mile	< 3,500	1
	> 3,500	2
1/2 Mile	< 2,600	1
	> 2,600	2
1 Mile	< 1,600	1
	> 1,600	2
> 1 Mile	N/A	2

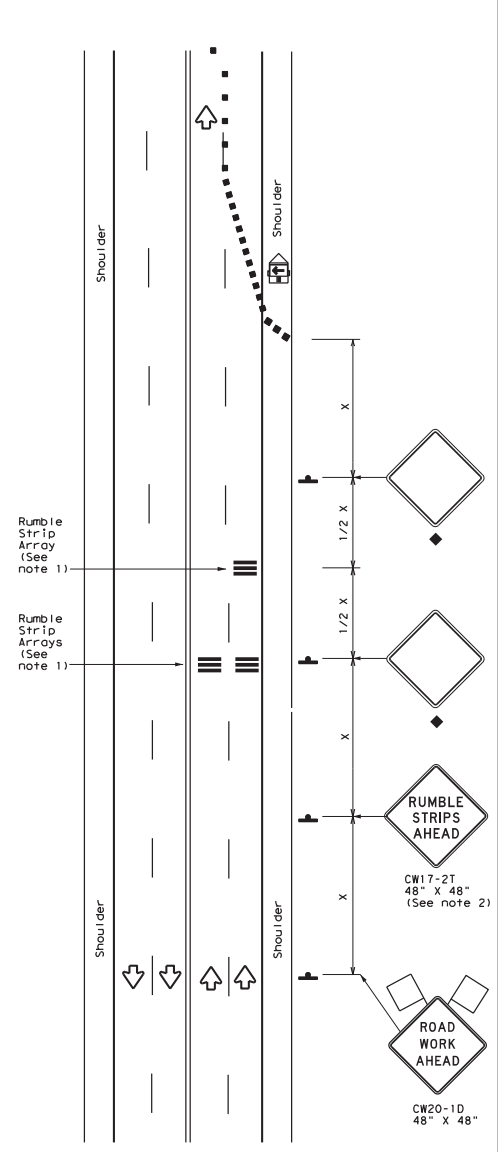

WZ (RS-1b)  
75 mph or Less  
**RUMBLE STRIPS FOR LANE CLOSURE ON CONVENTIONAL ROADWAY**

**GENERAL NOTES**

- Each Rumble Strip Array should consist of three rumble strips spaced center to center of the spacing shown in Table 2, placed transverse across the lane at locations shown.
- The CW17-2T "RUMBLE STRIPS AHEAD" sign should be located after the CW20-1D "ROAD WORK AHEAD" sign and spaced as shown. If traffic is observed to be queuing, or is expected to queue beyond the Rumble Strips, the CW17-2T sign and the first Rumble Strip Array may be located upstream of the CW20-1D sign as necessary to provide needed warning.
- Temporary Rumble Strips will be considered subsidiary to Item 502, and shall be a product listed on the Compliant Work Zone Traffic Control Devices.
- Removal of the Temporary Rumble Strips should be accomplished before removing the advance warning signs.
- Temporary Rumble Strips should not be used on horizontal curves, loose gravel, soft or bleeding asphalt, heavily rutted pavements or unpaved surfaces.
- Temporary Rumble Strips shall be installed and maintained as per manufacturer's recommendations.
- This standard sheet shall be used in conjunction with other appropriate TCP standard, TMUTCD typical application or project specific detail for the project.
- The one-lane two-way application may utilize a flagger, an AFAD or a portable traffic sign.
- Temporary Rumble Strips may be used on freeways or expressways based on engineering judgment.

Speed	Approximate distance between strips in an Array
≤ 40 MPH	10'
> 40 MPH & ≤ 55 MPH	15'
> 55 MPH	20'

	Type 3 Barricade		Channelizing Devices
	Heavy Work Vehicle		Truck Mounted Attenuator (TMA)
	Trailer Mounted Flashing Arrow Panel		Portable Changeable Message Sign (PCMS)
	Sign		Traffic Flag
	Flag		Flagger

Posted Speed *	Formula *	Minimum Desirable Taper Lengths **			Suggested Maximum Spacing of Channelizing Devices		Minimum Sign Spacing "x"	Suggested Longitudinal Buffer Space "b"
		10' Offset	11' Offset	12' Offset	On a Taper	On a Tangent		
30	L = WS <sup>2</sup> / 60	150'	165'	180'	30'	60'	120'	90'
35		205'	225'	245'	35'	70'	160'	120'
40	L = WS	265'	295'	320'	40'	80'	240'	155'
45		450'	495'	540'	45'	90'	320'	195'
50	L = WS	500'	550'	600'	50'	100'	400'	240'
55		550'	605'	660'	55'	110'	500'	295'
60	L = WS	600'	660'	720'	60'	120'	600'	350'
65		650'	715'	780'	65'	130'	700'	410'
70	L = WS	700'	770'	840'	70'	140'	800'	475'
75		750'	825'	900'	75'	150'	900'	540'

\* Conventional Roads Only  
 \*\* Taper lengths have been rounded off.  
 L=Length of Taper (FT) W=Width of Offset (FT)  
 S=Posted Speed (MPH)

MOBILE	SHORT DURATION	SHORT TERM STATIONARY	INTERMEDIATE TERM STATIONARY	LONG TERM STATIONARY
	✓	✓		

◆ Signs are for illustrative purposes only. Signs required may vary depending on the TCP, TMUTCD Typical Application, or project specific details for the project.

Texas Department of Transportation  
 Traffic Operations Division Standard

**TEMPORARY RUMBLE STRIPS**

**WZ (RS) - 16**

FILE: wzrs16.dgn	DATE: TxDOT November 2012	CONT: 6379	SECT: 46	JOB: 001	SH: 320, ETC
REVISIONS		BIST	COUNTY	WACO	FALLS
2-14	4-16				SHEET NO. 49

DISCLAIMER: This standard is governed by the "Texas Engineering Practice Act". No warranty of any kind is made by TxDOT for any purpose whatsoever. TxDOT assumes no responsibility for the conversion of this standard to other formats or for incorrect results or damages resulting from its use.

DATE: 3/23/2021 9:46:27 AM  
 FILE: T:\MACMINTY\TMC\Contr\CFR\8\Bose\01\ure\_Pvm\Main\FY-2022\FALLS\CADD\SHEETS\STANDARDS\pm1-20.dgn

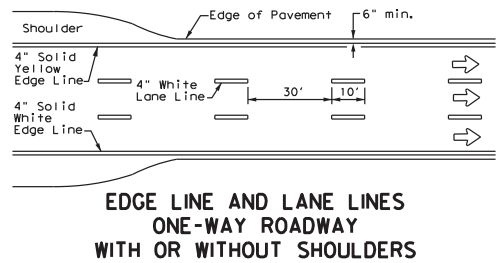

**EDGE LINE AND LANE LINES  
ONE-WAY ROADWAY  
WITH OR WITHOUT SHOULDERS**

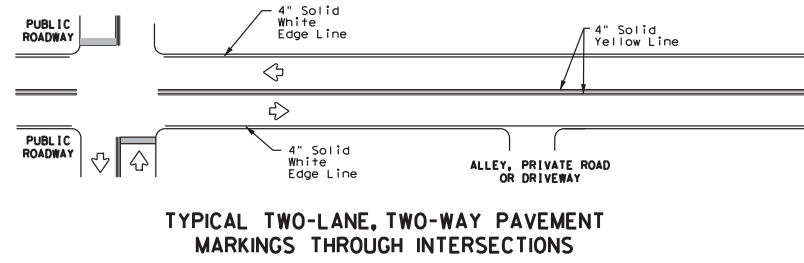

**TYPICAL TWO-LANE, TWO-WAY PAVEMENT  
MARKINGS THROUGH INTERSECTIONS**

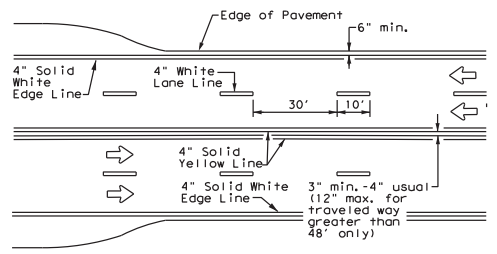

**CENTERLINE AND LANE LINES  
FOUR LANE TWO-WAY ROADWAY  
WITH OR WITHOUT SHOULDERS**

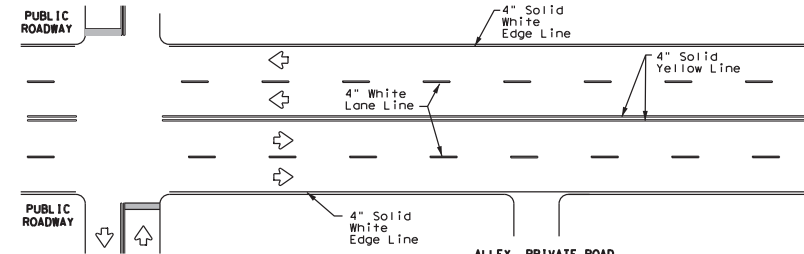

**TYPICAL MULTI-LANE, TWO-WAY PAVEMENT  
MARKINGS THROUGH INTERSECTIONS**

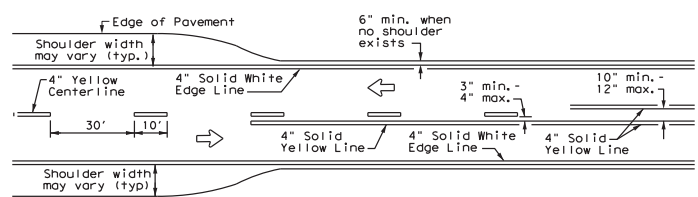

**TWO LANE TWO-WAY ROADWAY  
WITH OR WITHOUT SHOULDERS**

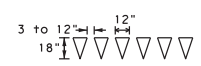

For posted speed on road being marked equal to or less than 40 MPH.

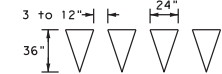

For posted speed on road being marked equal to or greater than 45 MPH.

**YIELD LINES**

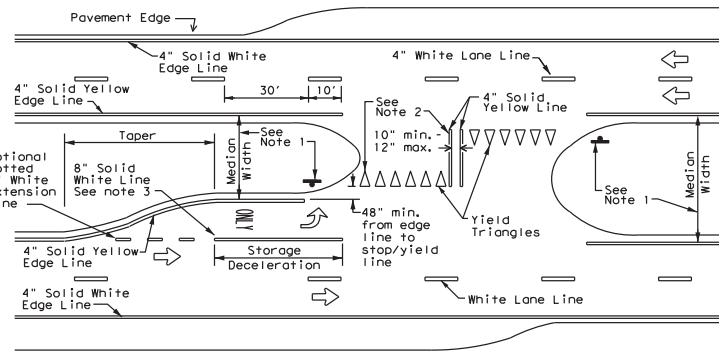

**FOUR LANE DIVIDED ROADWAY CROSSOVERS**

**NOTES**

1. Where divided highways are separated by median widths at the median opening itself of 30 feet or more, median openings shall be signed as two separate intersections. Each median opening has two width measurements, with one measurement for each approach. The narrow median width will be the controlling width to determine if signs are required. Yield signs are the typical intersection control. Stop signs are optional as determined by the Engineer.
2. Install median striping (double yellow centerlines and stop bars/yield triangles) when a 50' or greater median centerline can be placed. Stop bars shall only be used with stop signs. Yield triangles shall only be used with yield signs.
3. Length of turn bays, including taper, deceleration, and storage lengths shall be as shown on the plans or as directed by the Engineer.

**GENERAL NOTES**

1. Edgeline striping shall be as shown in the plans or as directed by the Engineer. The edgeline should not be placed less than 6 inches from the edge of pavement. This distance may vary due to pavement raveling or other conditions. Edgelines are not required in curb and gutter sections of roadways.
2. The traveled way includes only that portion of the roadway used for vehicular travel. It does not include the parking lanes, sidewalks, berms and shoulders. The traveled ways shall be measured from the inside of edgeline to the inside of edgeline of a two lane roadway.

MATERIAL SPECIFICATIONS	
PAVEMENT MARKERS (REFLECTORIZED)	DMS-4200
EPOXY AND ADHESIVES	DMS-6100
BITUMINOUS ADHESIVE FOR PAVEMENT MARKERS	DMS-6130
TRAFFIC PAINT	DMS-8200
HOT APPLIED THERMOPLASTIC	DMS-8220
PERMANENT PREFABRICATED PAVEMENT MARKINGS	DMS-8240

All pavement marking materials shall meet the required Departmental Material Specifications as specified by the plans.

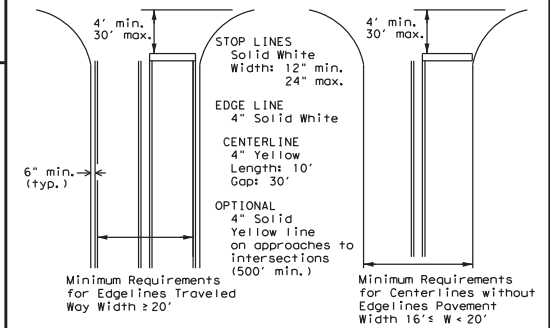

**GUIDE FOR PLACEMENT OF STOP LINES,  
EDGE LINE & CENTERLINE**

Based on Traveled Way and Pavement Widths for Undivided Highways



**TYPICAL STANDARD  
PAVEMENT MARKINGS**

**PM(1) - 20**

FILE: pm1-20.dgn	DATE: 11/14/18	CHK: [ ]	DATE: [ ]	CHK: [ ]
© TxDOT November 1978	CONT SECT: 6379 46	JOB: 001	SH: 320, ETC	HIGHWAY: [ ]
8-95 3-03 REVISIONS	DIST: [ ]	COUNTY: [ ]	SHEET NO.:	[ ]
5-00 2-12	WACO	FALLS	50	
8-00 6-20				

### REFLECTIVE RAISED PAVEMENT MARKERS FOR VEHICLE POSITIONING GUIDANCE

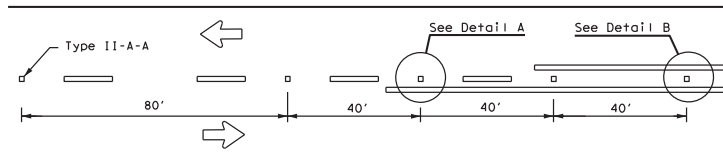

**CENTERLINE FOR ALL TWO LANE ROADWAYS**

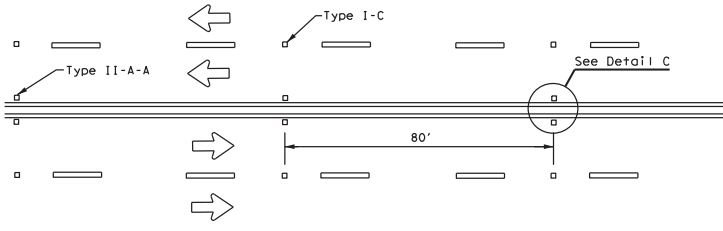

**CENTERLINE & LANE LINES  
FOR FOUR LANE TWO-WAY HIGHWAYS**

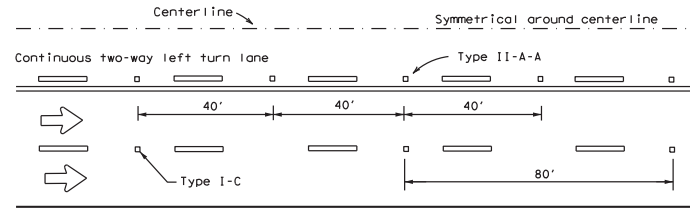
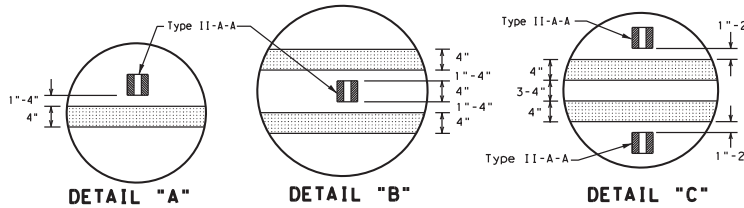

**CENTERLINE AND LANE LINES FOR TWO-WAY LEFT TURN LANE**

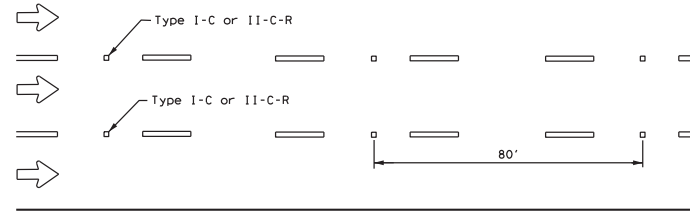

**LANE LINES FOR ONE-WAY ROADWAY (NON-FREWAY FACILITIES)**

Raised pavement markers Type II-C-R shall have clear face toward normal traffic and red face toward wrong-way traffic.

MATERIAL SPECIFICATIONS	
PAVEMENT MARKERS (REFLECTORIZED)	DMS-4200
EPOXY AND ADHESIVES	DMS-6100
BITUMINOUS ADHESIVE FOR PAVEMENT MARKERS	DMS-6130
TRAFFIC PAINT	DMS-8200
HOT APPLIED THERMOPLASTIC	DMS-8220
PERMANENT PREFABRICATED PAVEMENT MARKINGS	DMS-8240

All pavement marking materials shall meet the required Departmental Material Specifications as specified by the plans.

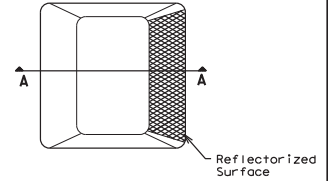

**Type I (Top View)**

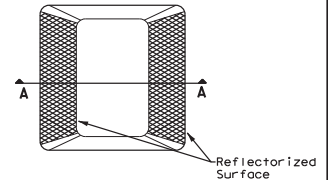

**Type II (Top View)**

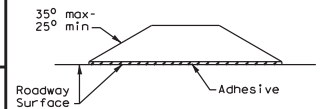

**RAISED PAVEMENT MARKERS**

**GENERAL NOTES**

- All raised pavement markers placed in broken lines shall be placed in line with and midway between the stripes.
- On concrete pavements the raised pavement markers should be placed to one side of the longitudinal joints.



**POSITION GUIDANCE USING  
RAISED MARKERS  
REFLECTORIZED PROFILE  
MARKINGS  
PM(2) - 20**

FILE: pm2-20.dgn	DATE: 08/20/2021	BY: [ ]	CHECKED: [ ]	DATE: [ ]	CHECKED: [ ]
© TXDOT April 1977	CONT: 6379	SECT: 46	JOB: 001	SH: 320, ETC	
4-92 2-10 REVISIONS	BIST: [ ]	COUNTY: [ ]	CITY: [ ]	SHEET NO. [ ]	
5-00 2-12	WACO	FALLS		51	
8-00 6-20					

DISCLAIMER: This standard is governed by the "Texas Engineering Practice Act". No warranty of any kind is made by TxDOT for any purpose whatsoever. TxDOT assumes no responsibility for the conversion of this standard to other formats or for incorrect results or damages resulting from its use.

DATE: 3/23/2021 9:46:31 AM FILE: T:\MACMINTY\TMC\CONTRACTS\Bosef011ure\_Pvm\Main\FY-2022\FALLS\CADD\SHEETS\STANDARDS\pm2-20.dgn

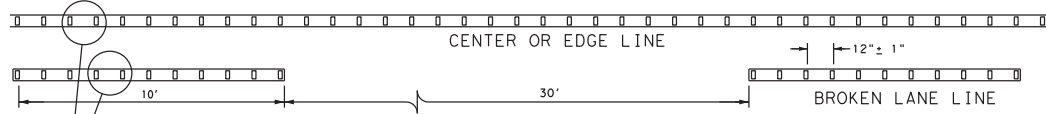

**REFLECTORIZED PROFILE  
PATTERN DETAIL**

USING REFLECTIVE PROFILE PAVEMENT MARKINGS

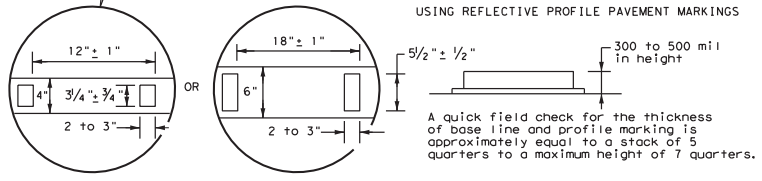

**NOTE**  
Profile markings shall not be placed on roadways with a posted speed limit of 45 MPH or less.

DISCLAIMER: This standard is governed by the "Texas Engineering Practice Act". No warranty of any kind is made by TxDOT for any purpose whatsoever. TxDOT assumes no responsibility for the conversion of this standard to other formats or for incorrect results or damages resulting from its use.

DATE: 3/23/2021 9:46:36 AM  
FILE: T:\MACAINT\T-RMC\Contr\Proc\Bases\G1\ure\_P\m\m\m\FY-2022\FALLS\CADD\SHEETS\STANDARDS\pm3-20.dgn

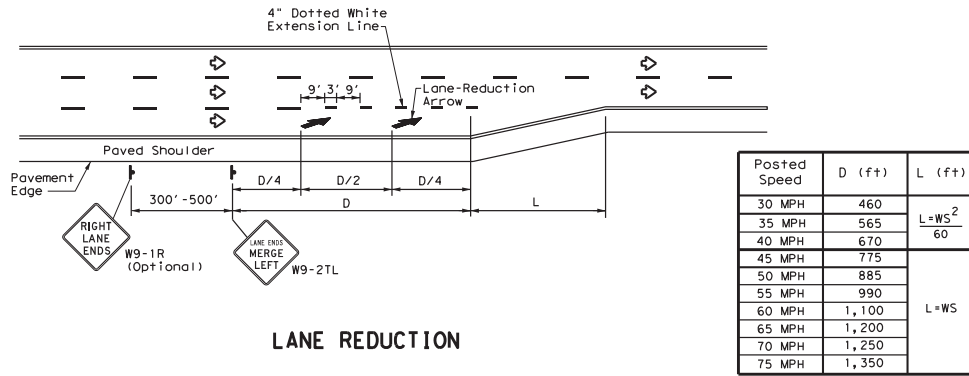

**LANE REDUCTION**

**NOTES**

- Lane reduction pavement markings are used where the number of through lanes is reduced because of narrowing of the roadway or because of a section of on-street parking in what would otherwise be a through lane. For Texas Super 2 Passing Lanes, see TS2(PL) standard sheets.
- On divided highways, an additional W9-1R "RIGHT LANE ENDS" sign may be installed in the median aligned with the W9-1R sign on the right side of the highway.
- Lane reduction arrows are required for speeds of 45 mph or greater. An optional third lane reduction arrow may be added based on engineering judgement. If used, the optional third lane reduction arrow should be centered between the first and last lane reduction arrows.
- For lane reductions on Freeways and Expressways, signing shall conform to the TxDOT Freeway Signing Handbook.

**GENERAL NOTES**

- Lane use word and arrow markings shall be used where through lanes approaching an intersection become mandatory turn lanes. Lane use word and arrow markings should be used in auxiliary lanes of substantial length. Lane use arrow markings or word and arrow markings may be used in other lanes and turn bays for emphasis. Details for words and arrows are as shown in the Standard Highway Sign Designs for Texas.
- When lane-use words and arrow markings are used, two sets of arrows should be used if the length of the bay is greater than 180 feet. When a single lane use arrow or word and arrow marking is used for a short turn lane, it should be located at or near the upstream end of the full-width turn lane.
- Use raised pavement marker Type I-C with undivided highways, flush medians and two way left turn lanes. Use raised pavement marker Type II-C-R with divided highways and raised medians.
- Length of turn bays, including taper, deceleration, and storage lengths shall be as shown on the plans or as directed by the Engineer.

MATERIAL SPECIFICATIONS	
PAVEMENT MARKERS (REFLECTORIZED)	DMS-4200
EPOXY AND ADHESIVES	DMS-6100
BITUMINOUS ADHESIVE FOR PAVEMENT MARKERS	DMS-6130
TRAFFIC PAINT	DMS-8200
HOT APPLIED THERMOPLASTIC	DMS-8220
PERMANENT PREFABRICATED PAVEMENT MARKINGS	DMS-8240

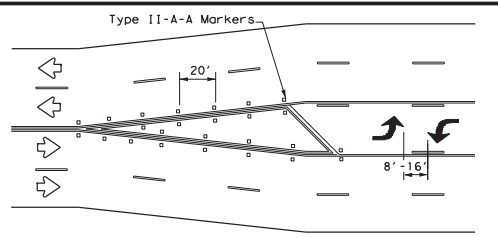

A two-way left-turn (TWLTL) lane-use arrow pavement marking should be used at or just downstream from the beginning of a two-way left-turn lane within a corridor. Repeating the marking after each intersection or dedicated turn bay is not required unless stated elsewhere in the plans.

**TYPICAL TRANSITION FOR TWLTL AND DIVIDED HIGHWAY**

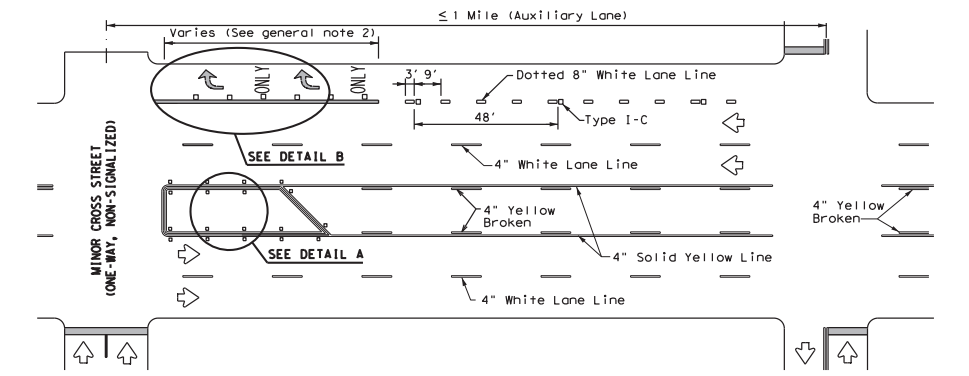

**TYPICAL TWLTL AT ONE-WAY STREET AND RIGHT TURN AUXILIARY LANE**

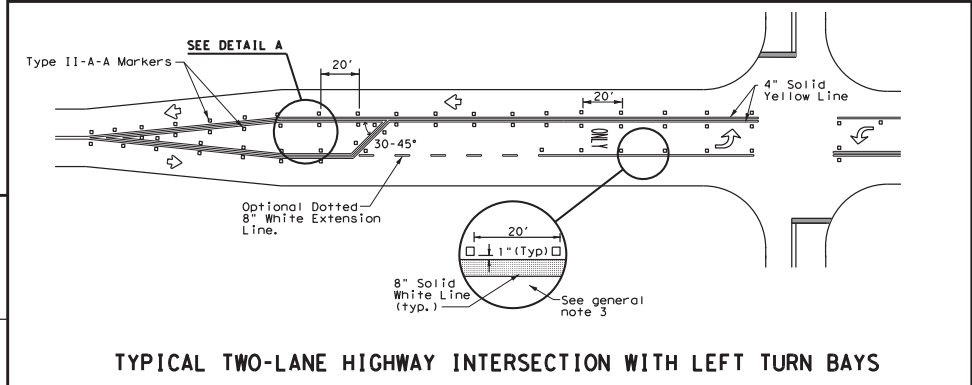

**TYPICAL TWO-LANE HIGHWAY INTERSECTION WITH LEFT TURN BAYS**

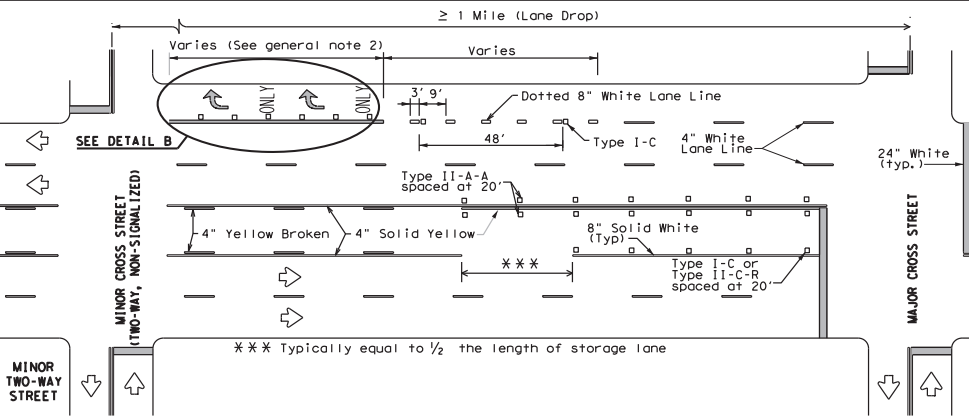

**TYPICAL TWLTL AT TWO-WAY CROSS STREET AND RIGHT TURN LANE DROP**

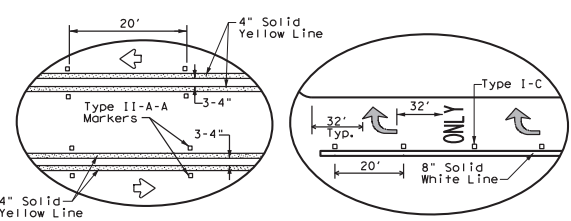

**DETAIL A**

**DETAIL B**

Texas Department of Transportation  
Traffic Safety Division Standard

**TWO-WAY LEFT TURN LANES, RURAL LEFT TURN BAYS, AND LANE REDUCTION PAVEMENT MARKINGS PM(3)-20**

FILE: pm3-20.dgn	DATE: 3/23/2021	BY: [ ]	CHECKED: [ ]	DATE: [ ]
© TxDOT April 1998	CONT: 6379	SECT: 46	JOB: 001	HIGHWAY: SH 320, ETC
REVISIONS:	DATE:	BY:	REASON:	
5-00	2-10			
8-00	2-12			
3-03	6-20			
WACO	COUNTY:	FALLS	SHEET NO.:	52



DISCLAIMER: This standard is governed by the "Texas Engineering Practice Act". No warranty of any kind is made by TxDOT for any purpose whatsoever. TxDOT assumes no responsibility for the conversion of this standard to other formats or for incorrect results or damages resulting from its use.

DATE: 3/23/2021 9:46:43 AM  
FILE: T:\WACMAINT\...RMC\_Contractors\Bosef01\ure\_Pvm\Main\FY-2022\FALLS\CADD\SHEETS\STANDARDS\pmd-20.dgn

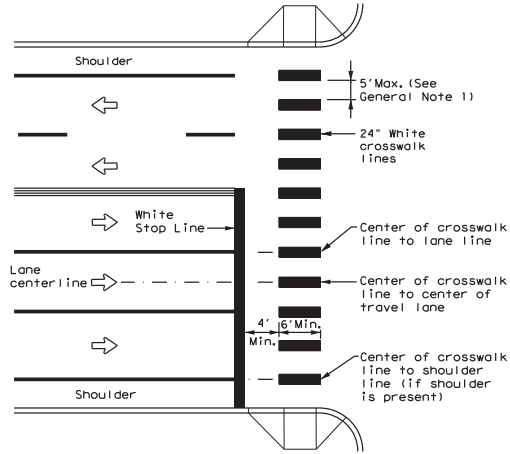

**HIGH-VISIBILITY LONGITUDINAL CROSSWALK AT CONTROLLED APPROACH**

**GENERAL NOTES**

1. Longitudinal crosswalk lines should not be placed in the wheel path of vehicles. Center the crosswalk lines on travel lanes, lane lines, and shoulder lines (if present).
2. A minimum 6" clear distance shall be provided to the curb face. If the last crosswalk line falls into this distance it must be omitted.
3. For divided roadways, adjustments in spacing of the crosswalk lines should be made in the median so that the crosswalk lines are maintained in their proper location across the travel portion of the roadway.
4. At skewed crosswalks, the crosswalk lines are to remain parallel to the lane lines.
5. Each crosswalk shall be a minimum of 6' wide.
6. The High-Visibility Longitudinal Crosswalk is the preferred crosswalk pattern on State Highways. Other crosswalk patterns as shown in the "Texas Manual on Uniform Traffic Control Devices" may be used. All crosswalk designs and dimension shall comply with the "Texas Manual on Uniform Traffic Control Devices."
7. Final placement of Stop Bar/Yield Triangles and Crosswalk shall be approved by the Engineer in the field.

MATERIAL SPECIFICATIONS	
PAVEMENT MARKERS (REFLECTORIZED)	DMS-4200
EPOXY AND ADHESIVES	DMS-6100
BITUMINOUS ADHESIVE FOR PAVEMENT MARKERS	DMS-6130
TRAFFIC PAINT	DMS-8200
HOT APPLIED THERMOPLASTIC	DMS-8220
PERMANENT PREFABRICATED PAVEMENT MARKINGS	DMS-8240

All pavement marking materials shall meet the required Departmental Material Specifications as specified by the plans.

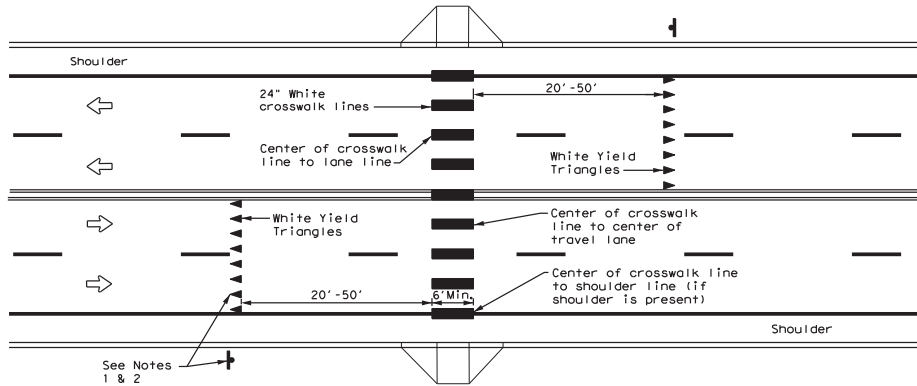

**UNSIGNALIZED MID BLOCK HIGH-VISIBILITY LONGITUDINAL CROSSWALK**

**NOTES**

1. Use yield triangles with "Yield Here to Pedestrians" signs at unsignalized mid block crosswalks.
2. Use stop bars with "Stop Here on Red" signs at mid block crosswalks controlled by traffic signals or pedestrian hybrid beacons.

		Traffic Safety Division Standard	
<b>CROSSWALK PAVEMENT MARKINGS</b>			
<b>PM (4) - 20</b>			
FILE: pm4-20.dgn	DATE: JUN 2020	CR1:	CR2:
REVISIONS	CONT SECT	JOB	HIGHWAY
	6379 46	001	SH 320, ETC
DIST	COUNTY	SHEET NO.	
WACO	FALLS	53	

DISCLAIMER: The use of this standard is governed by the "Texas Engineering Practice Act". No warranty of any kind is made by TxDOT for any purpose whatsoever. TxDOT assumes no responsibility for the conversion of this standard to other formats or for incorrect results or damages resulting from its use.

DATE: 3/23/2021 9:46:46 AM  
 FILE: T:\MCM\INT\VRMC-CONTRACTS\Bose\G01\ure\p\m\m\cadd\sheet\STANDARDS\FPM-12.DGN

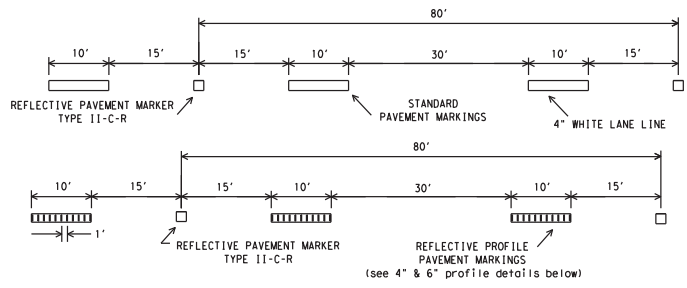

PAVEMENT MARKERS (REFL) TYPE II-C-R SHALL BE SPACED ON 80' CENTERS WITH THE CLEAR FACE TOWARD NORMAL TRAFFIC AND THE RED FACE TOWARD WRONG WAY TRAFFIC.

**TRAFFIC LANE LINES PAVEMENT MARKING DETAILS**

EDGE LINES SHOULD TYPICALLY BE 4" WIDE AND THE MATERIALS SHALL BE AS SPECIFIED IN THE PLANS. IF RAISED PROFILE PAVEMENT MARKINGS ARE USED SEE DETAILS BELOW.

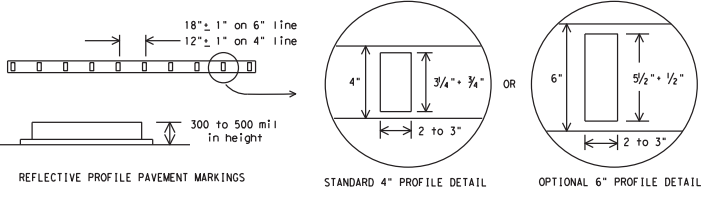

**EDGE LINE PAVEMENT MARKINGS**

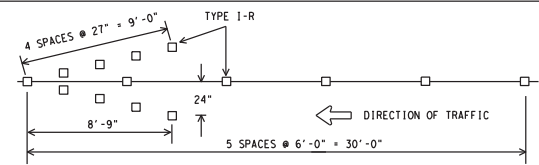

ALL RAISED MARKERS IN THE WRONG WAY ARROW SHALL BE TYPE I-R REFLECTORIZED PAVEMENT MARKERS WITH THE REFLECTORIZED SURFACE FACING THE WRONG WAY TRAFFIC. TYPE II-C-R SHALL NOT BE USED. REFLECTORIZED WRONG WAY ARROWS, NOT TO EXCEED TWO, MAY BE PLACED ON EXIT RAMP. LOCATION OF THE ARROWS SHALL BE AS SHOWN IN THE PLANS OR AS DIRECTED BY THE ENGINEER.

**WRONG WAY ARROW DETAIL**

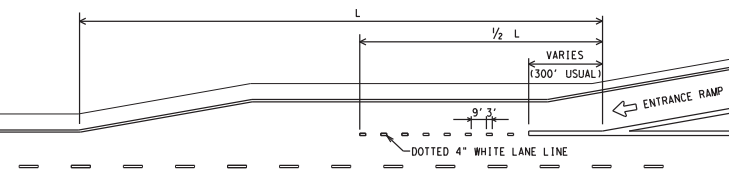

**PARALLEL ACCELERATION LANE**

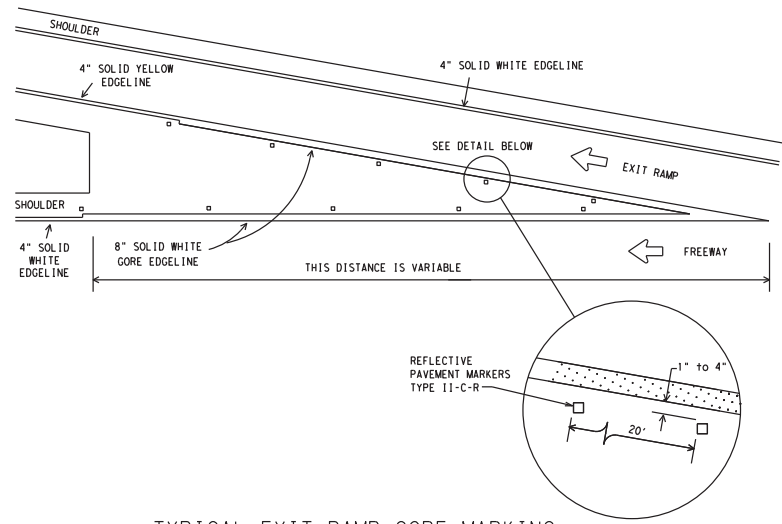

**TYPICAL EXIT RAMP GORE MARKING**

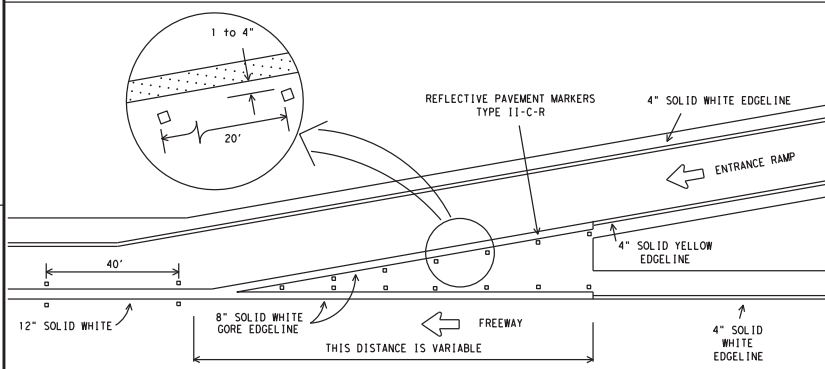

**TYPICAL ENTRANCE RAMP GORE MARKING**

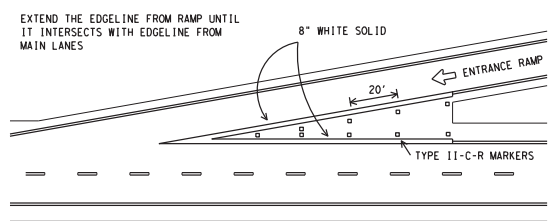

**TAPERED ACCELERATION LANE**

MATERIAL SPECIFICATIONS	
PAVEMENT MARKERS (REFLECTORIZED)	DMS-4200
EPOXY AND ADHESIVES	DMS-6100
BITUMINOUS ADHESIVE FOR PAVEMENT MARKERS	DMS-6130
TRAFFIC PAINT	DMS-8200
HOT APPLIED THERMOPLASTIC	DMS-8220
PERMANENT PREFABRICATED PAVEMENT MARKINGS	DMS-8240

All pavement marking materials shall meet the required Departmental Material Specifications as specified by the plans.

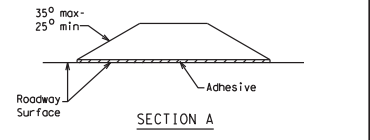
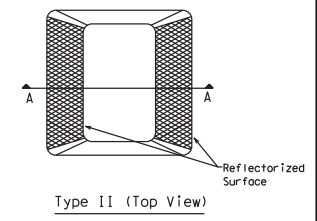
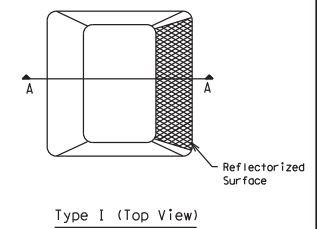

**RAISED PAVEMENT MARKERS**

Texas Department of Transportation  
Traffic Operations Division

**TYPICAL STANDARD FREEWAY PAVEMENT MARKINGS WITH RAISED PAVEMENT MARKERS**  
FPM(1)-12

REVISIONS		CONTRACT NO.	SECTION	JOB NO.	HIGHWAY
4-92	2-10	6379	46	001	SH 320, ETC
5-00	2-12				
8-00		DIST		COUNTY	SHEET NO.
2-08		WACO		FALLS	54

DISCLAIMER: The use of this standard is governed by the "Texas Engineering Practice Act". No warranty of any kind is made by TxDOT for any purpose whatsoever. TxDOT assumes no responsibility for the conversion of this standard to other formats or for incorrect results or damages resulting from its use.

DATE: 3/23/2021 9:46:49 AM  
 FILE: T:\MACMAINT\TRMC\CONTRACTS\Bosef01\urep\m\m\m\fy-2022\FALLS\CADD\SHEETS\STANDARDS\FPM-12.DGN

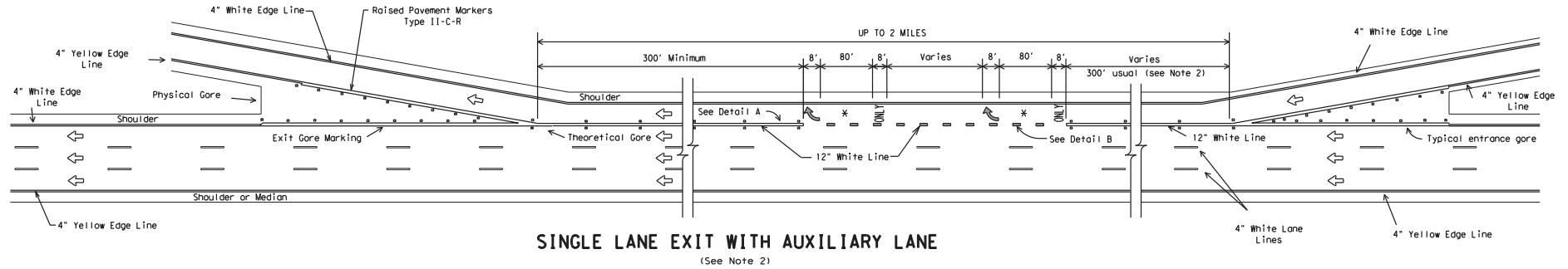

**SINGLE LANE EXIT WITH AUXILIARY LANE**  
(See Note 2)

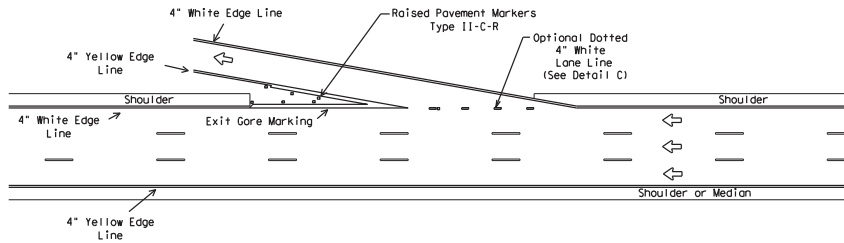

**TAPERED DECELERATION LANE**

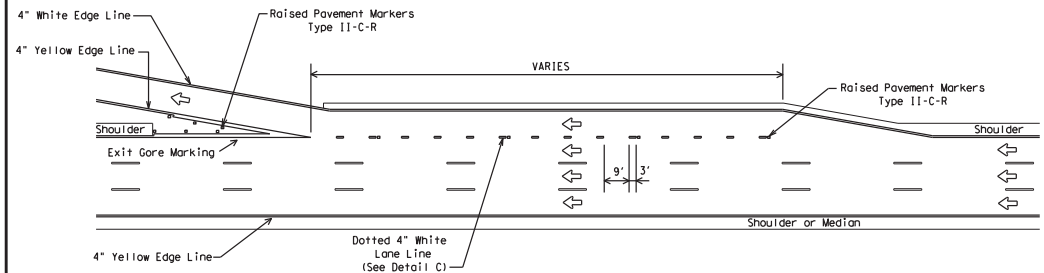

**PARALLEL DECELERATION LANE**

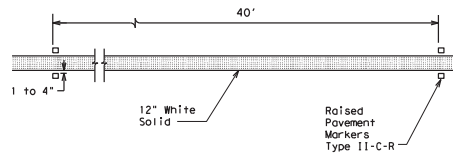

**DETAIL A**

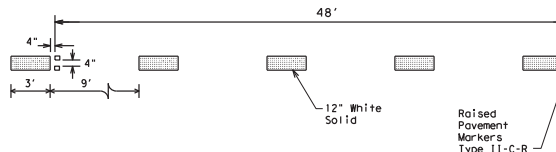

**DETAIL B**  
Wide (12") Dotted Lane Line (See Note 3)

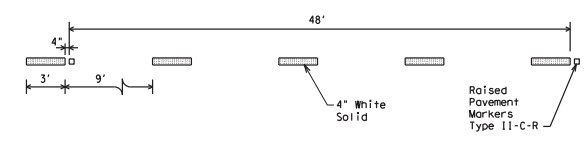

**DETAIL C**  
Normal (4") Dotted Lane Line (See Note 4)

**GENERAL NOTES**

1. Pavement markings shall be white except as otherwise noted.
2. Length of 12" white line may vary depending on location.
3. Wide (12") Dotted Lane Line (See Detail B) is used to separate a through lane from a lane drop at normal exit ramp and from an auxiliary lane between an entrance and exit ramp.
4. Normal (4") Dotted Lane Line (See Detail C) is used at parallel acceleration and deceleration lanes.

**LEGEND**

	Denotes direction of traffic.
	Pavement marking arrows (white)
	Arrow markings are optional, however "ONLY" is required if arrow is used

**MATERIAL SPECIFICATIONS**

PAVEMENT MARKERS (REFLECTORIZED)	DMS-4200
EPOXY AND ADHESIVES	DMS-6100
BITUMINOUS ADHESIVE FOR PAVEMENT MARKERS	DMS-6130
TRAFFIC PAINT	DMS-8200
HOT APPLIED THERMOPLASTIC	DMS-8220
PERMANENT PREFABRICATED PAVEMENT MARKINGS	DMS-8240

All pavement marking materials shall meet the required Departmental Material Specifications as specified by the plans.



**TYPICAL STANDARD  
FREEWAY PAVEMENT MARKINGS  
ENTRANCE AND EXIT RAMP**  
**FPM(2) - 12**

© TxDOT February 1977		DN: TxDOT	CK: TxDOT	DN: TxDOT	CK: TxDOT
REVISIONS		CONT	SECT	JOB	HIGHWAY
4-92	2-10	6379	46	001	SH 320, ETC
8-95	2-12				
5-00		DIST		COUNTY	SHEET NO.
8-00		WACO		FALLS	55

DISCLAIMER: The use of this standard is governed by the "Texas Engineering Practice Act". No warranty of any kind is made by TxDOT for any purpose whatsoever. TxDOT assumes no responsibility for the conversion of this standard to other formats or for incorrect results or damages resulting from its use.

DATE: 3/23/2021 9:46:51 AM  
FILE: T:\MACMINTY\RMIC\Contr\cfrs\Bose\G1\ure\p\mt\m\fy--2022\FALLS\CADD\SHEETS\STANDARDS\FPM3-12.DGN

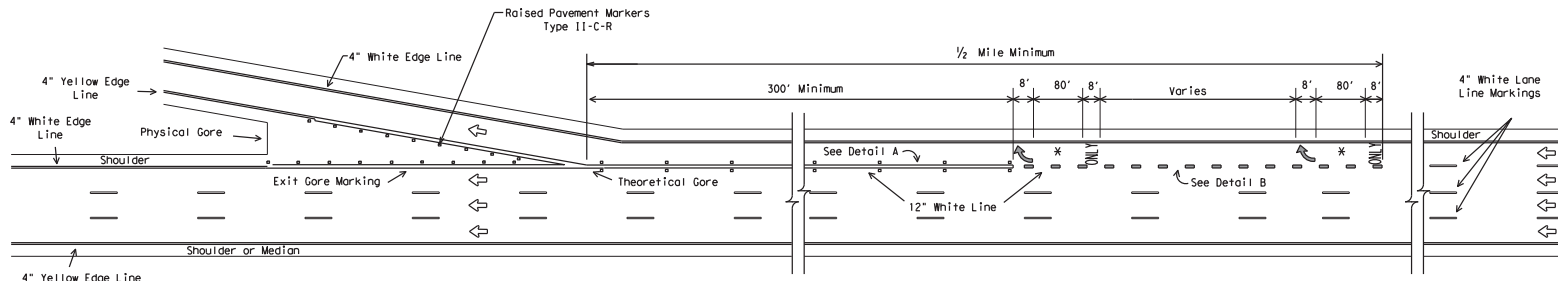

**SINGLE LANE EXIT - LANE DROP OR EXIT ONLY**

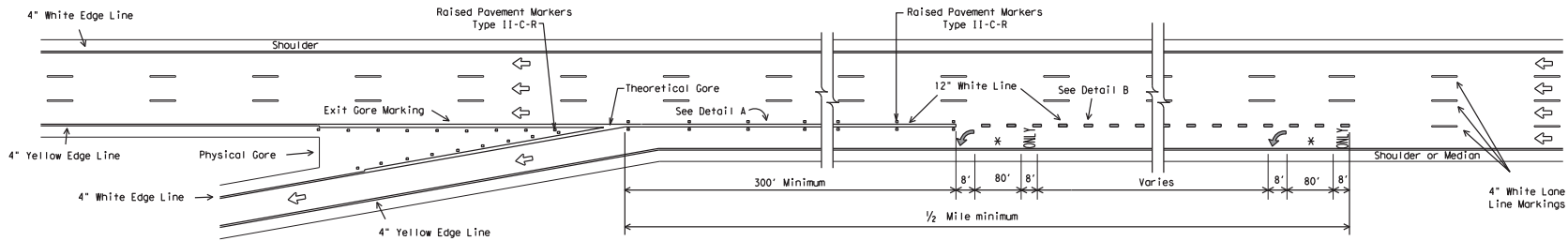

**SINGLE LANE EXIT - LANE DROP OR EXIT ONLY (LEFTHAND)**

LEGEND	
	Denotes direction of traffic.
	Pavement marking arrows (white)
	Arrow markings are optional, however "ONLY" is required if arrow is used

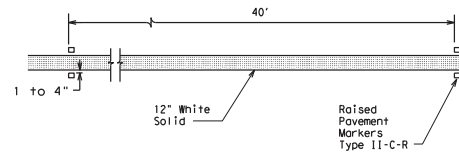

**DETAIL A**

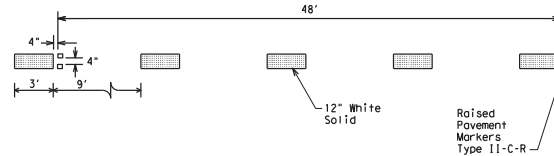

**DETAIL B**

Wide (12") Dotted Lane Line (See Note 3)

MATERIAL SPECIFICATIONS	
PAVEMENT MARKERS (REFLECTORIZED)	DMS-4200
EPOXY AND ADHESIVES	DMS-6100
BITUMINOUS ADHESIVE FOR PAVEMENT MARKERS	DMS-6130
TRAFFIC PAINT	DMS-8200
HOT APPLIED THERMOPLASTIC	DMS-8220
PERMANENT PREFABRICATED PAVEMENT MARKINGS	DMS-8240

All pavement marking materials shall meet the required Departmental Material Specifications as specified by the plans.

**GENERAL NOTES**

1. Pavement markings shall be white except as otherwise noted.
2. Length of 12" white line may vary depending on location.
3. Wide (12") Dotted Lane Line (See Detail B) is used to separate a through lane from a lane drop at normal exit ramp and from an auxiliary lane between an entrance and exit ramp.

Texas Department of Transportation  
Traffic Operations Division

**TYPICAL STANDARD  
FREEWAY PAVEMENT MARKINGS  
LANE DROP (EXIT ONLY) EXIT RAMP**

**FPM(3) - 12**

© TxDOT April 1992		DN: TxDOT	CK: TxDOT	DN: TxDOT	CK: TxDOT
REVISIONS					
5-00	CONT	SECT	JOB	HIGHWAY	
8-00	6379	46	001	SH 320, ETC	
2-10	DIST	COUNTY		SHEET NO.	
2-12	WACO	FALLS		56	

DISCLAIMER: The use of this standard is governed by the "Texas Engineering Practice Act". No warranty of any kind is made by TxDOT for any purpose whatsoever. TxDOT assumes no responsibility for the conversion of this standard to other formats or for incorrect results or damages resulting from its use.

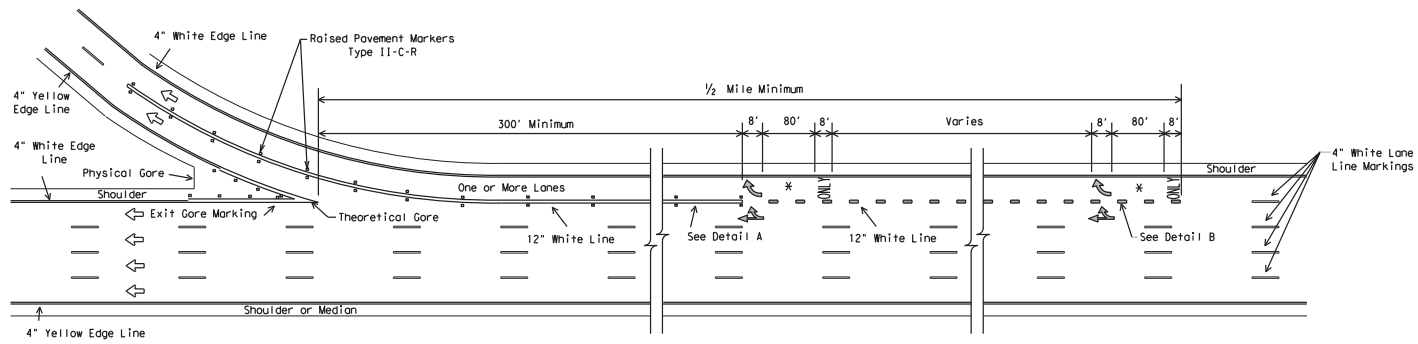

**MULTIPLE LANE EXIT - EXIT ONLY WITH OPTION LANE**

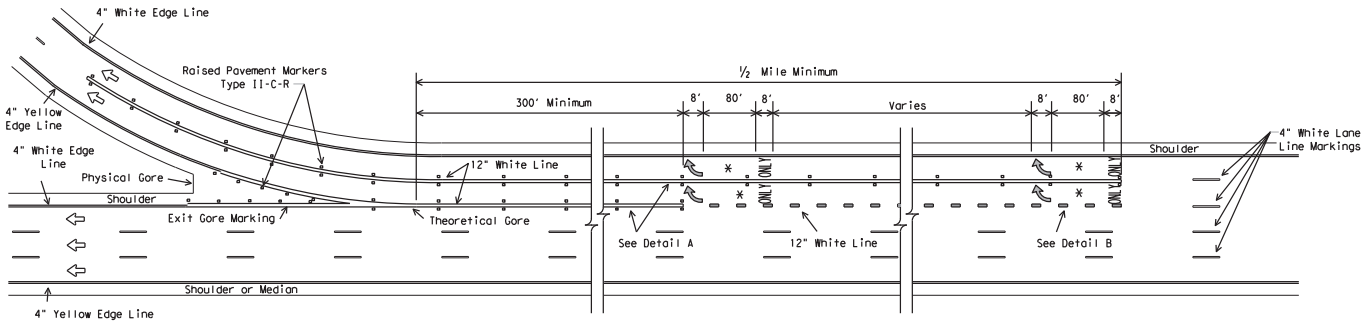

**MULTIPLE LANE EXIT ONLY**

LEGEND	
	Denotes direction of traffic
	Pavement marking arrow (white)
	Optional Pavement Marking Arrows (white)
	Arrow markings are optional, however "ONLY" is required if arrow is used

**GENERAL NOTES**

- Pavement markings shall be white except as otherwise noted.
- Length of 12" white line may vary depending on location.
- Wide (12") Dotted Lane Line (See Detail B) is used to separate a through lane from a lane drop at normal exit ramp and from an auxiliary lane between an entrance and exit ramp.

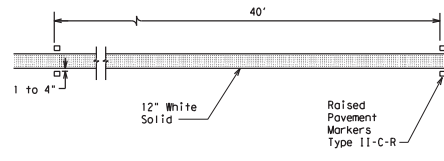

**DETAIL A**

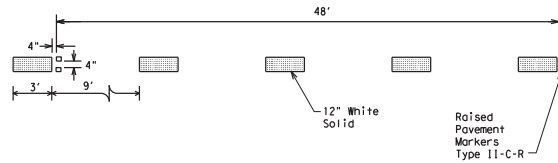

**DETAIL B**

Wide (12") Dotted Lane Line (See Note 3)

MATERIAL SPECIFICATIONS	
PAVEMENT MARKERS (REFLECTORIZED)	DMS-4200
EPOXY AND ADHESIVES	DMS-6100
BITUMINOUS ADHESIVE FOR PAVEMENT MARKERS	DMS-6130
TRAFFIC PAINT	DMS-8200
HOT APPLIED THERMOPLASTIC	DMS-8220
PERMANENT PREFABRICATED PAVEMENT MARKINGS	DMS-8240

All pavement marking materials shall meet the required Departmental Material Specifications as specified by the plans.



**TYPICAL STANDARD  
FREEWAY PAVEMENT MARKINGS  
LANE DROP (EXIT ONLY) DETAILS**

**FPM(4) - 12**

REVISIONS		CONT	SECT	JOB	HIGHWAY
5-00		6379	46	001	SH 320, ETC
8-00					
2-10					
2-12					
		WACO	FALLS		SHEET NO.
					57

**EXIT NUMBER PAVEMENT MARKING NOTES**

1. Minimum 8 foot white markings should be used, unless otherwise noted.
2. Spacing between letters and numbers should be approximately 4 inches.
3. Pavement markings are to be located as specified elsewhere in the plans.
4. All pavement marking materials shall meet the required Departmental Material Specifications or as specified in these plans.
5. Numbers and Letters details can be found in the Standard Highway Design for Texas (SHSD) Chapter 12 at <http://www.txdot.gov>

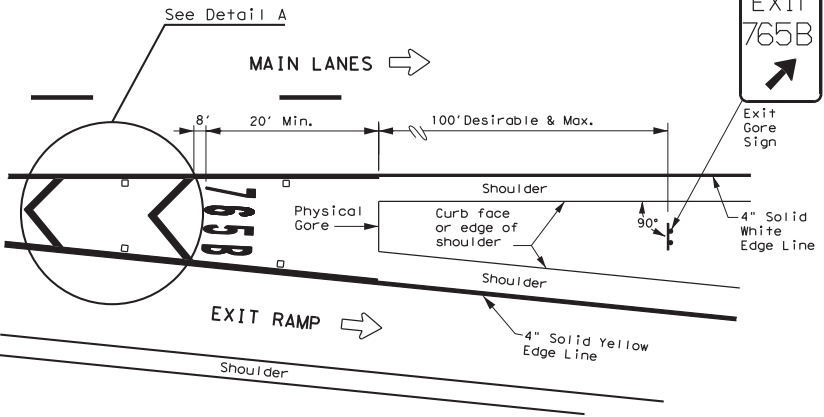

**MARKINGS WITH EXIT NUMBER**

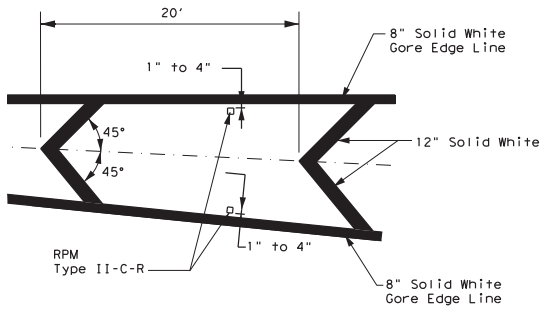

- NOTES**
1. Raised pavement markers shall be centered between chevron or gore lines.
  2. For more information, see ReflectORIZED Raised Pavement Marker Detail.

**DETAIL A**

**MATERIAL SPECIFICATIONS**

PAVEMENT MARKERS (REFLECTORIZED)	DMS-4200
EPOXY AND ADHESIVES	DMS-6100
BITUMINOUS ADHESIVE FOR PAVEMENT MARKERS	DMS-6130
TRAFFIC PAINT	DMS-8200
HOT APPLIED THERMOPLASTIC	DMS-8220
PERMANENT PREFABRICATED PAVEMENT MARKINGS	DMS-8240

All pavement marking materials shall meet the required Departmental Material Specifications as specified by the plans.

**LEGEND**

	Traffic flow
	ReflectORIZED Raised Markers (RPM) Type II-C-R

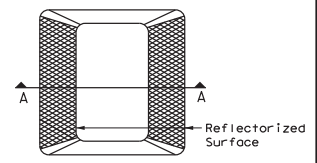

**Type II (Top View)**

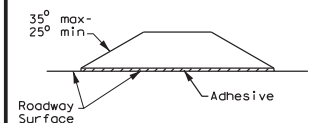

**SECTION A**

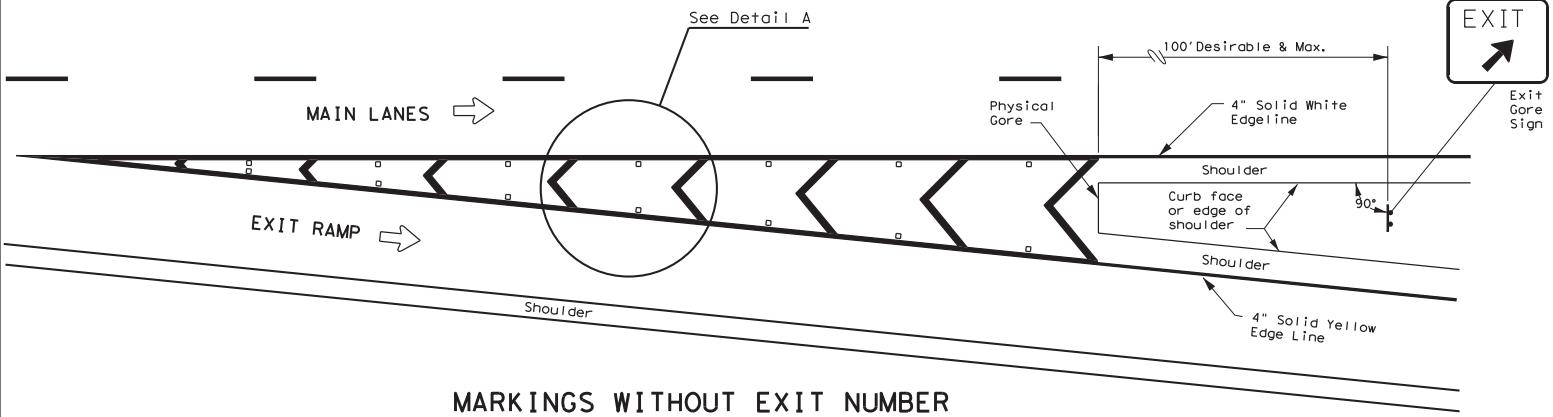

**MARKINGS WITHOUT EXIT NUMBER**

**REFLECTORIZED RAISED PAVEMENT MARKER (RPM)**



**EXIT GORE PAVEMENT MARKINGS**

**FPM(5) - 19**

FILE: fpm(5)-19.dgn	DATE: 09/15/2019	BY: [initials]	CHECKED: [initials]	DATE: [initials]	CHECKED: [initials]
© TXDOT September 2019	CONT: 6379	SECT: 46	JOB: 001	SH: 320	ETC
DIST: WACO		COUNTY: FALLS		SHEET NO. 58	

DISCLAIMER: The use of this standard is governed by the "Texas Engineering Practice Act". No warranty of any kind is made by TxDOT for any purpose whatsoever. TxDOT assumes no responsibility for the conversion or for incorrect results or damages resulting from its use.

DATE: 3/23/2021 9:46:58 AM  
FILE: T:\MACMAINT\1-RMC-Contr\0318\Bosef\01\ure\_Pvm\Main\FY-2022\FALLS\CADD\SHEETS\SRW\SRW5\K0101-1-10.dwg

DISCLAIMER: This standard is governed by the "Texas Engineering Practice Act". No warranty of any kind is made by TxDOT for any purpose whatsoever. TxDOT assumes no responsibility for the conversion of this standard to other formats or for incorrect results or damages resulting from its use.

3/23/2021 9:47:03 AM T:\MACMINT\TMC\_Contracts\Base\01\ure\_P\m\m\int\FY-2022\FALLS\CADD\SHEETS\STANDARDS\ec1-16.dgn

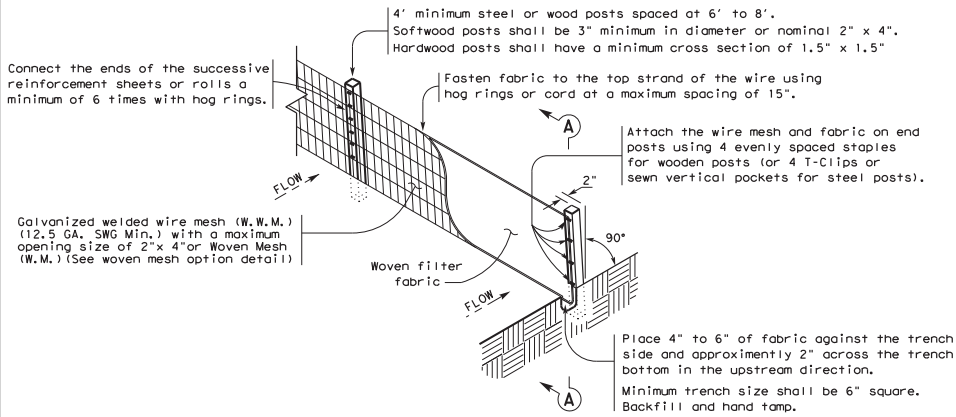

**TEMPORARY SEDIMENT CONTROL FENCE**

SCF

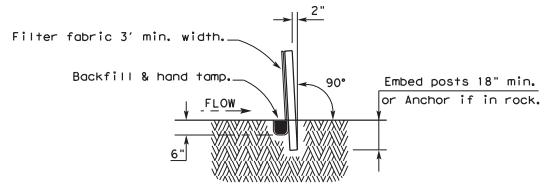
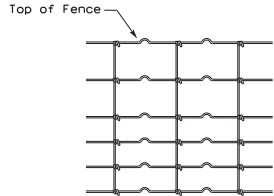

**HINGE JOINT KNOT WOVEN MESH (OPTION) DETAIL**

Galvanized hinge joint knot woven mesh (12.5 GA. SWG Min.) requires a minimum of five horizontal wires spaced at a maximum of 12 inches apart and all vertical wires spaced at a maximum of 12 inches apart.

**SEDIMENT CONTROL FENCE USAGE GUIDELINES**

A sediment control fence may be constructed near the downstream perimeter of a disturbed area along a contour to intercept sediment from overland runoff. A 2 year storm frequency may be used to calculate the flow rate to be filtered.

Sediment control fence should be sized to filter a maximum flow through rate of 100 GPM/FT<sup>2</sup>. Sediment control fence is not recommended to control erosion from a drainage area larger than 2 acres.

**LEGEND**

Sediment Control Fence

SCF

**GENERAL NOTES**

1. Vertical tracking is required on projects where soil distributing activities have occurred unless otherwise approved.
2. Perform vertical tracking on slopes to temporarily stabilize soil.
3. Provide equipment with a track undercarriage capable of producing linear soil impressions measuring a minimum of 12" in length by 2" to 4" in width by 1/2" to 2" in depth.
4. Do not exceed 12" between track impressions.
5. Install continuous linear track impressions where the minimum 12" length impressions are perpendicular to the slope or direction of water flow.

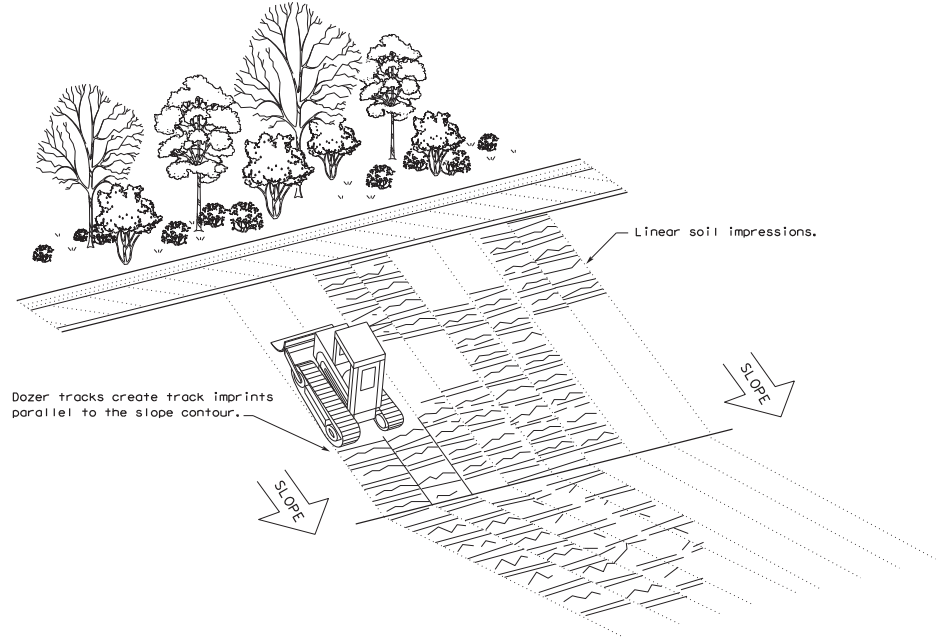

**VERTICAL TRACKING**



**TEMPORARY EROSION, SEDIMENT AND WATER POLLUTION CONTROL MEASURES FENCE & VERTICAL TRACKING EC(1)-16**

FILE: ec116	DN: TxDOT	CR: KM	DN: VP	DN/CR: LS
© TxDOT: JULY 2016	CONT	SECT	JOB	HIGHWAY
REVISIONS	6379	46	001	SH 320, ETC
DIST	COUNTY		SHEET NO.	
WACO	FALLS		59	

## BEST MANAGEMENT PRACTICE (BMP) GENERAL NOTES

1. Prior to TxDOT allowing the Contractor to start construction, the Contractor will provide the required storm water and 404 permit documentation and support activities, including but not limited to the following:
  - Provide a list of all chemicals, construction and waste products that will be generated, stored or brought upon TxDOT ROW. The list includes expected construction debris, sanitary wastes, construction chemicals and petroleum products used or generated by the Contractor and sub-contractors. Along with the list, the Contractor will supply a spill prevention plan and clean up procedures that will include each of these chemical products or generated waste.
  - Provide in the construction schedule the necessary line items that will comply with the schedule and planning requirements of the storm water permit.
  - Post the TxDOT storm water permit and any Contractor permits, per permit requirements.
  - Provide copies of storm water permits for Contractor PSL(s). As new PSL(s) may be obtained for the project, provide copies of new or amended permits to TxDOT. The Contractor will not disturb soil without the proper permits.
  - Provide scale drawings of off ROW PSL's within one mile of the project, for field offices, borrow sources, plant sites or other uses.
  - Provide permit information on any Contractor batch plants or concrete crushing plants to be located at a Contractor PSL(s) within one mile of the project limits or boundaries. Copies of the air and water permits are to be provided to TxDOT before materials will be used on the project. No asphalt or concrete batch plants or concrete crushing plants will be located on TxDOT ROW.
  - Provide a letter indicating a Contractor Responsible Person for environmental compliance (CRP) for the project, and maintain a CRP throughout the project duration.
  - Provide all environmental documentation including certification of compliance and EMS training documents/certificates prior to starting work. The Contractor is to provide daily BMP inspection reports that document all field BMPs needing repair or replacement. The Contractor is to clearly document specific BMPs needing repair and location each work day. The Contractor is encouraged to be proactive in fixing BMPs without TxDOT direction.
  - Provide documentation required for Waters of the US, Note #3 and submittals for Item 496 bridge removal. Bridge removal methods submitted will follow all Waters of the US note requirements. The Contractor is not to start construction within the Ordinary High Water Marks of any stream until receiving approval for stream channel construction methods from TxDOT.
  - Provide a written procedure for managing all chemicals and construction items placed in vertical containment structures. Also, provide methods to be used for the treatment, disposal, collection or release of storm water.
  - Provide an estimated date by letter, for the submittal of marked up bridge drawings, indicating cut locations for any structural steel requiring cutting or torching of steel, coated with lead containing paints.
2. Place and maintain trash cans and portable sanitary facilities at locations where there is active construction. Worker generated trash and construction debris will be kept from being transported by storm water and will be collected daily from the ground and routinely hauled from the work area.
3. Contractor will provide TxDOT copies of all correspondence with MS4s, TCEQ, EPA, DSHS and Corps of Engineers regarding activities on this project.
4. Contractor to conduct storm water inspections and develop SWPPP documents to support Contractor permits obtained for the project including PSL(s).
5. Contractor will maintain written documentation of locations of all portable sanitary facilities. The Contractor is required to document the location and disposition of all spills and cleanups from portable sanitary facilities.
6. Contractor will not store chemicals on TxDOT ROW, unless chemicals are stored following all environmental and safety regulations. Fuels for construction equipment will not be stored on TxDOT ROW.
7. The Contractor will store fuels and bulk chemicals on Contractor PSL(s) using a secondary containment method, such as double lined tanks and/or free standing containment reservoirs made of plastic or steel designed to hold bulk chemicals or drums.
8. The Contractor will not remove sediment controls without the prior approval of TxDOT, except for a sediment control that may back up water and cause safety or traffic problems.

SCALE = NTS SHEET 1 OF 10



**Texas Department of Transportation**  
Waco District Standard

**TYPICAL APPLICATIONS  
FOR  
BEST MANAGEMENT  
PRACTICES**

**TA - BMP**

FILES: BMPLAYOUTS.dgn	DN:	CK:	DN:	CK:
© TxDOT 2009	CONT	SECT	JOB	HIGHWAY
REVISIONS	6379	46	001	SH 320, ETC
DEC 2013	BIST	COUNTY	SHEET NO.	
FEB 2015	WACO	FALLS	60	

3/23/2021 9:47:07 AM T:\MAGMA\INT\...RMC\_Contractors\Base\01\ure\_Pvm\Map\Int\FY--2022\FALLS\CADD\SHEET\STANDARD\ST\TA - BMP - 2015\_Layouts.dgn



## BEST MANAGEMENT PRACTICE (BMP) GENERAL NOTES

9. Any sediment controls removed by the Contractor must be re-installed before the next rainfall event or by the end of day, as approved in advance.
10. Vegetative buffer strips may be used in place of temporary sediment controls such as silt fences and rock filter dams. The amount of disturbed soil area will be limited to 1/3 of an acre or less for a minimum of 50 feet of grassed ditch and 2/3 of an acre of disturbed soil for a minimum of 100 feet of grassed ditch.
11. Construction equipment found to be leaking oil, fuel or coolant will be immediately stopped, the leaking fluid collected and the equipment fixed. Equipment continuing to leak will be removed from the project at no cost to TxDOT. Leaking fluids from equipment will be collected and removed from the project or PSL.
12. Earth berms or mounds typically used to stockpile topsoil and used in place of boundary silt fence will be seeded upon being constructed. Long term use of earth berms or mounds will not be continued without establishing grass on the control.
13. The Contractor will inform TxDOT of new areas where soil will be disturbed to facilitate planning for new sediment controls. Areas of vegetated soil will not be disturbed by the Contractor, unless adequate sediment controls can be installed before the next rainfall event. The Contractor will assist TxDOT in keeping an accurate set of working SWPPP drawings that show the locations of all temporary sediment and erosion controls.
14. The Contractor will maintain an adequate amount of temporary sediment controls on hand at the field office or project staging area for critical SWPPP maintenance, including silt fence (minimum of 200 feet) and rock / fabric for rock filter dams (minimum for 100 feet of Type III dams).  
The requirement for BMP rock quantities on hand is waived for small projects for on and off system bridge installations. The Contractor having a BMP Subcontractor does not eliminate the requirement for the Contractor to have the required silt fence and rock on hand, typically stored at the Contractor PSL.
15. Failure of a sub-contractor to complete storm water work on time will require the Contractor to start storm water sediment control work immediately and complete the work with high priority, or be subject to stop work on the entire project.
16. Earth materials on roads as a result of soil tracking will not be allowed to be transported off ROW in storm water. Soil or rock material found on roadways deposited from Contractor equipment will be removed daily.
17. Unless approved, completed concrete curb inlets will not be blocked by sediment controls. The contractor will frequently sweep the completed or partially completed roadway to keep sediment out of drainage pipes.
18. The Contractor will be responsible for proper dust control and will route construction traffic in a manner that minimizes dust generation.
19. Water for dust control will contain no pollutants, but may be non-potable from upland stock ponds. No quantity of water to be used for construction purposes may be taken from a 404 stream, prior to the proper authorizations or permits being obtained by the Contractor.
20. Contractor is to direct workers and sub-contractors to use portable sanitary facilities provided by the Contractor and not to trespass off ROW.
21. Contractor will provide written verification to TxDOT that earth borrow pits and disposal sources meet environmental and regulatory requirements, prior to use. Excavations will meet all OSHA requirements and the current safety guidelines established for TxDOT Quarries and Pits.
22. Boundary silt fences that are terminated down slope, with one end being at the lowest elevation, will be installed with an L - hook to contain sediment. Boundary silt fences that are installed on flat ground will have L-hooks on both ends.
23. Rock filter dams across ditches will be constructed where the rock filter dam ends are embedded within the ditch side slopes and ditch bottom. The top center elevation of the rock filter dam will be at least 6 inches lower than the elevations on the rock filter dam ends.
24. Silt fence will be constructed in a U or V pattern across ditch lines and up the ditch side slope to keep storm water from flowing around the ends of the silt fence. Small silt fences that do not adequately span the ditch and allows storm water around the end(s) will not be used. Where there is adequate space, large U pattern silt fences are preferred to facilitate sediment collection and sediment removal with equipment.
25. Sediment controls (RFDs or silt fences) will be located along road ditches as marked on the SWPPP drawings. Modifications to the sediment control spacing will be adjusted during the project based on sediment control effectiveness. The installation and maintenance of sediment controls at or near outfalls, where storm water leaves TxDOT ROW, takes persistent over ditch line sediment controls.

SCALE = NTS SHEET 2 OF 10



**Texas Department of Transportation**  
Waco District Standard

**TYPICAL APPLICATIONS  
FOR  
BEST MANAGEMENT  
PRACTICES**

**TA - BMP**

FILES: BMP.LAYOUTS.dgn	DN:	CK:	DN:	CK:
© TxDOT 2009	CONT	SECT	JOB	HIGHWAY
REVISIONS	6379	46	001	SH 320, ETC
DEC 2013	DIST	COUNTY	SHEET NO.	
FEB 2015	WACO	FALLS	61	

3/23/2021 9:47:08 AM T:\MAGMA\INT\...RMC\_Contracts\Base\of\Ture\_P\mnt\mnt\fy-2022\FALLS\CADD\SHEETS\STANDARD\ST-TA-BMP-2015\_Layouts.dgn

## BEST MANAGEMENT PRACTICE (BMP) GENERAL NOTES

26. Storm water draining sheet flow over disturbed soil sloped towards the ROW property line, will be intercepted by a boundary silt fence typically installed with L-shaped ends.
27. For ditch grading and shoulder up work, the Contractor is limited during good weather to remove up to one mile (limited to five acres of disturbed soil) of ditch line sediment controls; on one side of the roadway. Outfall controls cannot be removed during this activity. Ditch line controls must be replaced upon completion of work and before the next rain event.
28. Sediment controls damaged by the Contractor, as defined by permit, must be fixed or replaced immediately upon discovery.
29. Notches in silt fences are not typically allowed. Specific silt fences that back up water onto lanes of traffic may be notched if approved.
30. For silt fence maintenance, the Contractor will leave approximately 4 inches of deposited sediment up stream of silt fences and not over excavate around silt fences or rock filter dams.
31. The Contractor will inform TxDOT of new construction areas and where soil is planned to be disturbed. Sediment controls will be installed at outfalls prior to the Contractor beginning soil disturbing activities up slope from the outfall.
32. Water from concrete saw cutting, concrete grinding and concrete coring activities; or fine materials from concrete chipping and salvage will not be allowed to enter storm drains or enter streams.
33. Storm water containing suspended sediment and turbidity needing to be removed from excavations or low areas will be pumped or gravity drained through vegetated buffer strips (50 foot minimum) or placed in ditches with temporary sediment controls, prior to the water being discharged into a stream.
34. Uncontaminated water from natural groundwater seepage, springs, foundations and drains that does not contain suspended sediment or any pollutants may be discharged without storm water controls.
35. Lime or cement if spilled in ditches or outside the defined limits of application is considered a pollutant and will be excavated and removed the same day, to avoid contaminating streams.
36. If located along the project ROW, RAP stockpiles will be located where there is a minimum 100 feet of vegetative buffer strip before storm water will reach a stream. RAP will not be used as a construction material within the Ordinary High Water Marks of a stream channel of a 404 designated stream.
37. If allowed on the project, concrete truck wash out areas will have adequate volume to allow 12 inch freeboard for rain and will be lined with 6 mils of plastic. No concrete will be stored higher than the 12 inch freeboard. Cleaning of truck chutes and equipment does not constitute concrete truck wash out and this activity may be completed at the concrete placement location. Wash out areas will not be located closer than 50 ft from down slope inlets or stream channels.
38. For outfalls near stock ponds closer than 50 foot from disturbed soil at the ROW line, redundant sediment controls will be provided, typically a combination of rock filter dam and a silt fence constructed in line of the flow.
39. Earth stockpiles will utilize silt fence sediment controls, positioned on the low end of the stockpile drainage area with L-hooks or silt fence installed around the entire stockpile.
40. Sediment controls including rock filter dams and silt fences will not be installed across any 404 streams. Sediment controls at 404 streams will be positioned to limit sediment entering the stream from the banks and around structures/culverts, and will allow free flow of storm water to pass through the ROW without being dammed by any sediment controls. Remove loose materials from stream channels prior to each rain event.
41. Sediment controls for non-404 streams may be constructed across the drainage channel in unlimited locations. It is appropriate to use sediment control details typically used for 404 streams for non-404 streams when flow velocities are high. Remove loose material from stream channels prior to each rain event.
42. Incomplete drainage pipe installation across the roadway does not remove the requirement for having sediment controls around the ends of the pipe. To stay within permit requirements, sediment controls should be installed over and around the terminated end and along each side of the banks as soon as construction on the pipe has been completed. Remove loose material from stream channels prior to each rain event.
43. Safety end / headwall construction temporarily will require the removal of part of the sediment control placed over and around the pipe end. Retain in place as much functioning sediment control as possible. Replace the silt fence over and around the top of the pipe, immediately upon concrete placement and form removal. Do not remove culvert sediment controls that cannot be replaced before the next rain event. Sediment control at the ends of culverts must be in place and available for any rain event until the disturbed soil areas are re-vegetated.

SCALE = NTS SHEET 3 OF 10



### TYPICAL APPLICATIONS FOR BEST MANAGEMENT PRACTICES

**TA-BMP**

FILES: BMLAYOUTS.dgn	DWF:	CK1:	DWF:	CK1:
© TxDOT 2009	CONT:	SECT:	JOB:	HIGHWAY:
REVISIONS	6379	46	001	SH 320, ETC
DEC 2013	DIST:	COUNTY:	SHEET NO.:	
FEB 2015	WACO	FALLS	62	

3/23/2021 9:47:08 AM T:\MAGMA\INT\...RMC\_Contract\Fs\Base\G1\Ture\_P\m\m\int\nt\FY--2022\FALLS\CADD\SHEETS\STANDARD\STA-BMP-2015\_Layouts.dgn

## BEST MANAGEMENT PRACTICE (BMP) GENERAL NOTES

44. Between the Ordinary High Water Marks of a 404 stream channel, the Contractor will disturb only the minimum amount of stream channel that is necessary to complete the work.
45. Rock riprap for erosion control does not replace the requirements to maintain sediment control until vegetation is re-established. Replace sediment controls immediately after installing erosion rock.
46. At the direction of TxDOT, sediment deposited into existing and new culverts will be removed subsidiary to Item 506. Sediment to be removed is either pre-existing material before construction starts or sediment generated as a part of this project.
47. Provide treated 2X4 cross bracing for rectangular inlet silt fence, subsidiary to Item 506.
48. Loose or granular earth materials will not be used to repair silt fence undercuts. Silt fence undercut repairs will be conducted with well compacted soils or the silt fence will be reset in a nearby location.
49. Silt fence steel T posts of approximately 1.25 pounds per foot are allowed at a spacing of 8 feet or less. Silt fence steel T posts between approximately 1.25 pounds per foot and 0.85 pounds per foot are allowed for T post spacing of 5 feet or less.
50. Silt fence to be used to slow the flow of storm water down slopes will be positioned approximately horizontal (on the contour) with L hooks on the ends and limited to approximately 200 feet in length. Multiple sections and levels of silt fence may be required in addition to temporary / permanent erosion control flumes.
51. Soil retention blankets will be installed rolled down the slope with the small dimension side embedded at the top of slope, unless recommended otherwise by the manufacturer. Excess grass, rocks, trash, debris or clods will be removed before seeding and installing soil retention blankets. All installations will be by the manufacturer recommendations. Contractor equipment, including tractor mowers will be kept off areas with soil retention blankets until the grass is established.

3/23/2021 9:47:09 AM T:\MAGM\INT\...RMC\_Contractors\Base\G1\Iure\_P\mnt\mnt\FY-2022\FALLS\CADD\SHEETS\STANDARDS\TA-BMP-2015\_Layouts.dgn

SCALE = NTS SHEET 4 OF 10



**Texas Department of Transportation**  
Waco District Standard

### TYPICAL APPLICATIONS FOR BEST MANAGEMENT PRACTICES

**TA-BMP**

FILES: BMPLAYOUTS.dgn	DN:	CK:	DN:	CK:
© TxDOT 2009	CONT	SECT	JOB	HIGHWAY
REVISIONS	6379	46	001	SH 320, ETC
DEC 2013	BIST	COUNTY	SHEET NO.	
FEB 2015	WACO	FALLS	63	

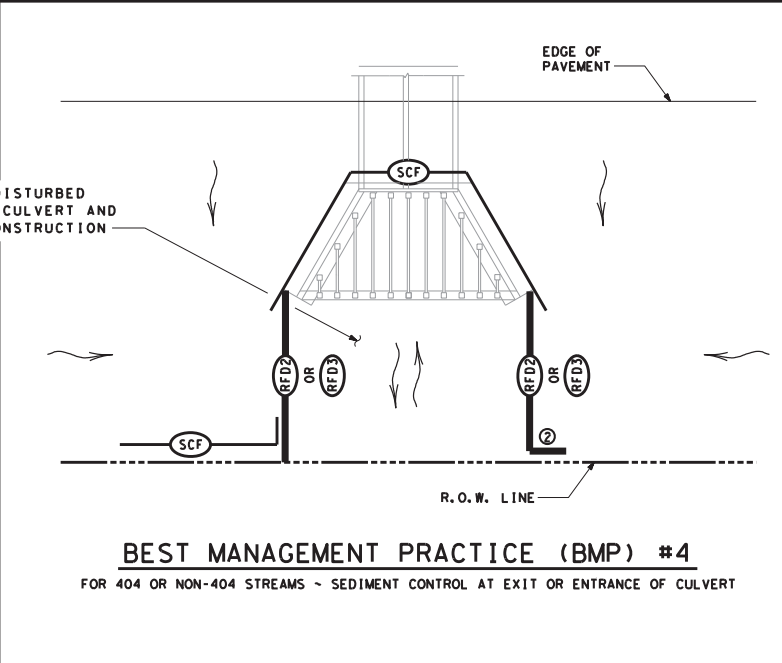
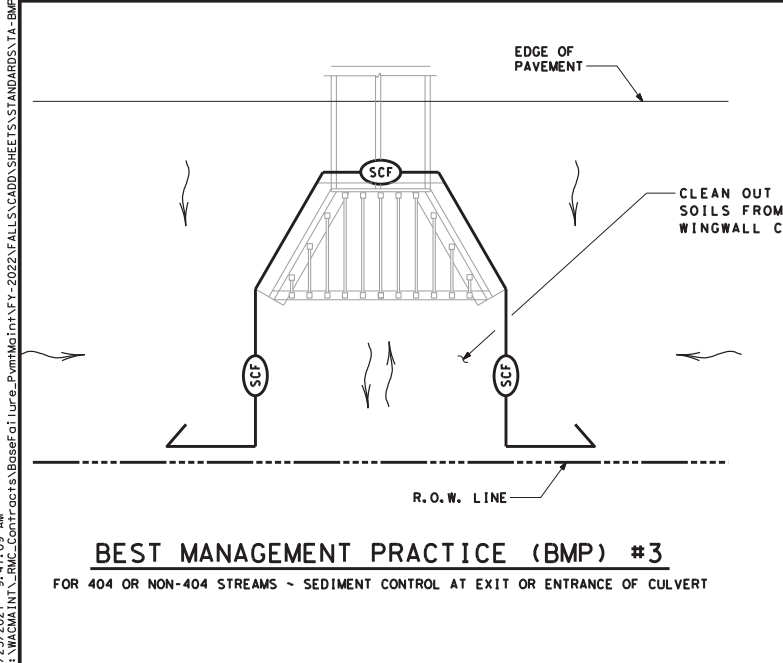
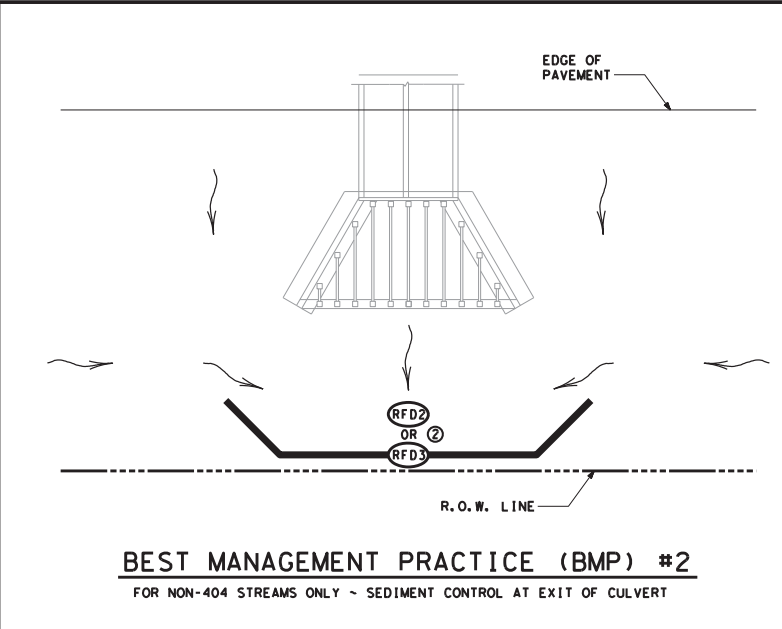
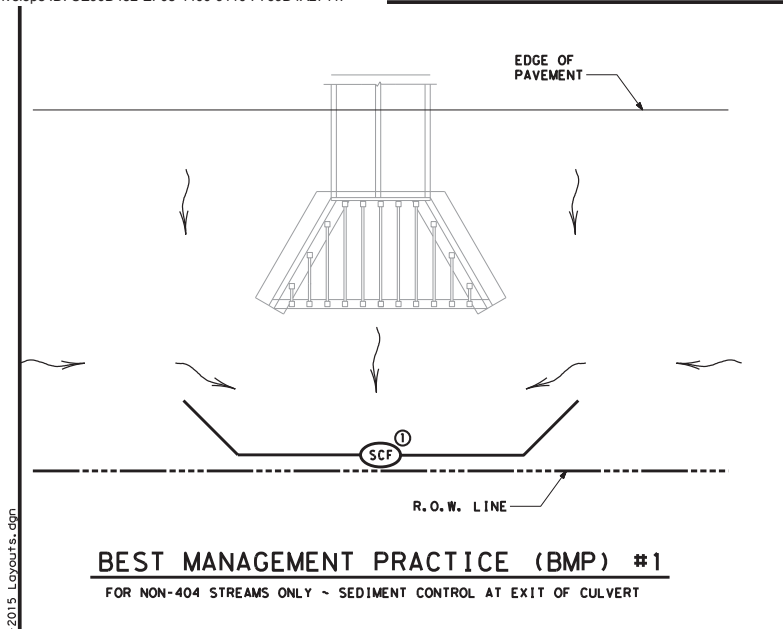

	SEDIMENT CONTROL FENCE
	ROCK FILTER DAM (TY 2)
	ROCK FILTER DAM (TY 3)
	DIRECTION OF FLOW

- NOTES:
- ① EXTEND SILT FENCE SO STORM WATER DOES NOT GO AROUND THE ENDS. USE L-HOOKS ON ENDS AS REQUIRED.
  - ② EXTEND ROCK FILTER DAM SO STORM WATER DOES NOT GO AROUND THE ENDS.

SCALE = NTS SHEET 5 OF 10



**TYPICAL APPLICATIONS FOR BEST MANAGEMENT PRACTICES**

**TA-BMP**

FILES: BMLAYOUTS.dgn	DN: TXDOT	CR: TXDOT	DR: TXDOT	CR: TXDOT
© TXDOT 2009	CONT	SECT	JOB	HIGHWAY
REVISIONS	6379	46	001	SH 320, ETC
DEC 2013	BIST	COUNTY	SHEET NO.	
FEB 2015	WACO	FALLS	64	

3/23/2021 9:47:09 AM  
 T:\MAGMA\INT\...RMC\_Contracts\Base\G1\ure\_P\m\g\int\...2022\FALLS\CADD\SHEETS\STANDARD\STA-BMP-2015 Layouts.dgn

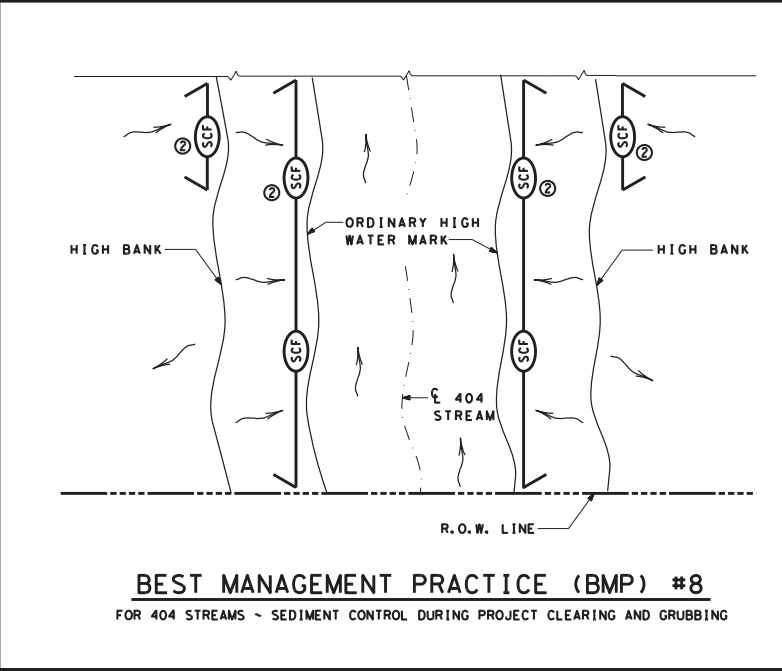
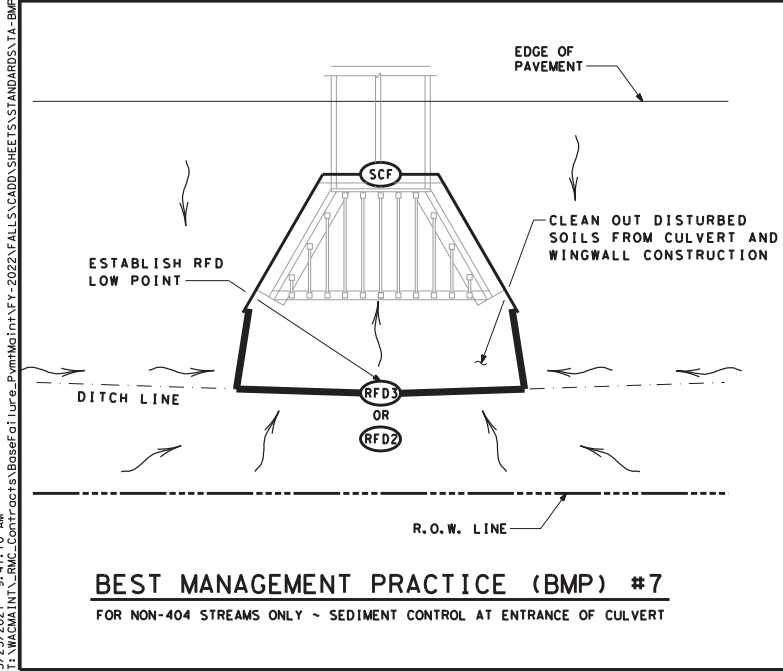
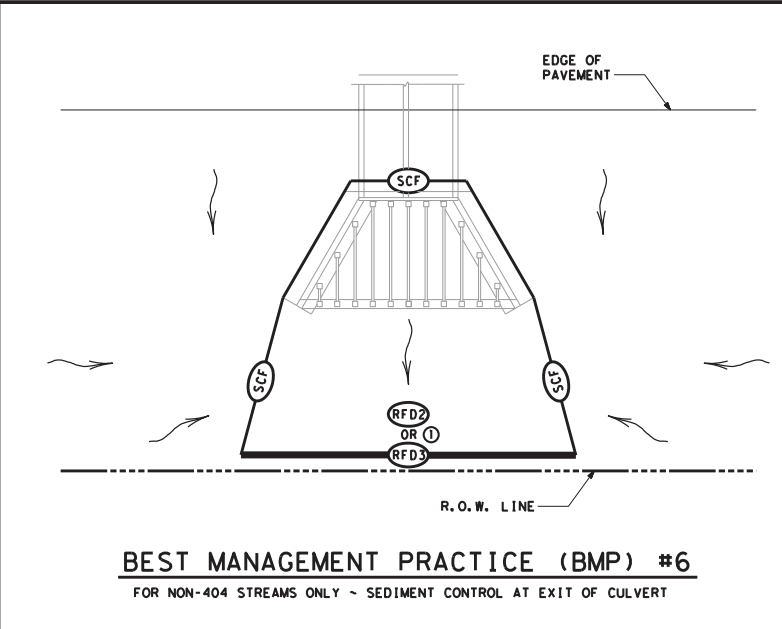
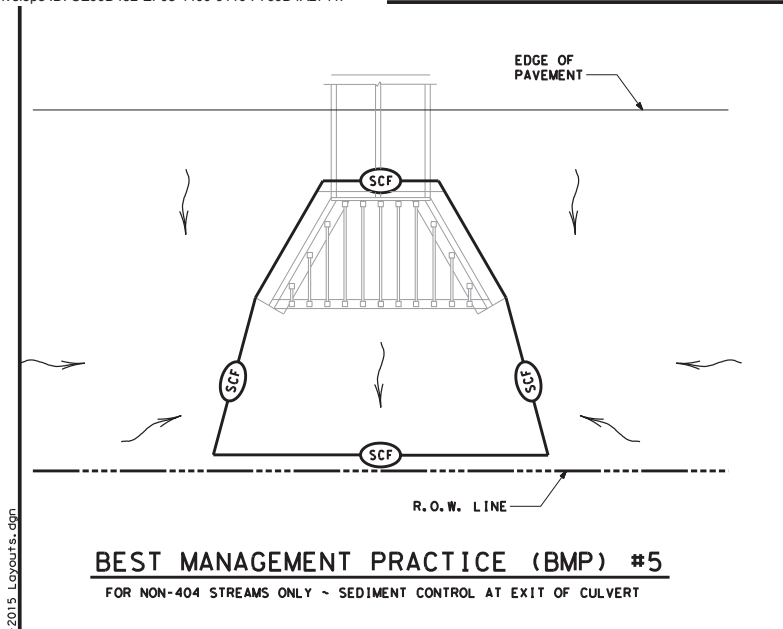

	SEDIMENT CONTROL FENCE
	ROCK FILTER DAM (TY 2)
	ROCK FILTER DAM (TY 3)
	DIRECTION OF FLOW

- NOTES:**
- PROVIDE OVERLAP OF SILT FENCE WITH ROCK FILTER DAM.
  - USE SILT FENCE L-HOOKS ON ENDS TO BLOCK STORM WATER SEDIMENT

SCALE = NTS SHEET 6 OF 10

**Texas Department of Transportation**  
Waco District Standard

**TYPICAL APPLICATIONS FOR BEST MANAGEMENT PRACTICES**

**TA-BMP**

FILES: BMLAYOUTS.dgn	DN: TXDOT	CR: TXDOT	DR: TXDOT	CK: TXDOT
© TXDOT 2009	CONT	SECT	JOB	HIGHWAY
REVISIONS	6379	46	001	SH 320, ETC
DEC 2013	B1ST	COUNTY	WACO	FALLS
FEB 2015				SHEET NO. 65

3/23/2021 9:47:10 AM T:\MAGMINT\...RMC\_Contract\Bases\G1\ure\_P\m\g\m\y-2022\FALLS\CADD\SHEETS\STANDARDS\TA-BMP-2015 Layouts.dgn

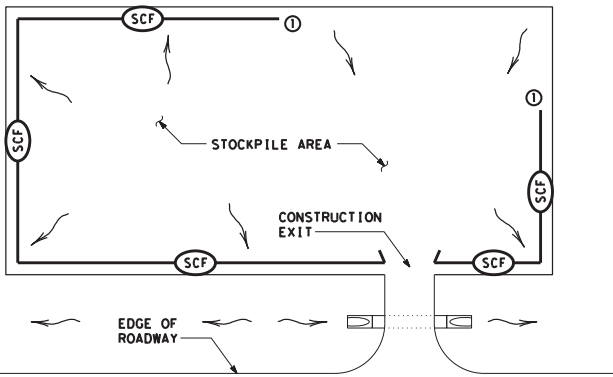

**BEST MANAGEMENT PRACTICE (BMP) #9**  
 STOCKPILE SEDIMENT CONTROL

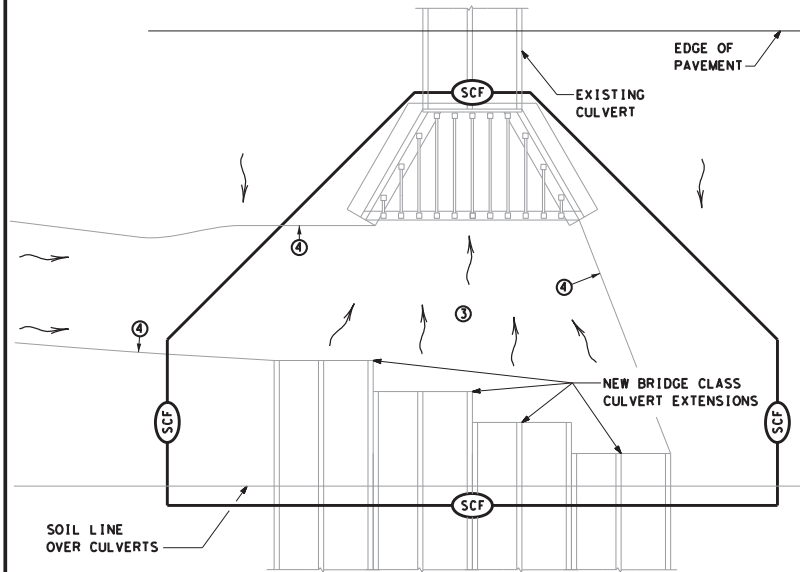

**BEST MANAGEMENT PRACTICE (BMP) #10**  
 FOR 404 OR NON-404 STREAMS ONLY ~  
 SEDIMENT CONTROL AT PHASED CONSTRUCTION OF BRIDGE CLASS CULVERTS

	SEDIMENT CONTROL FENCE
	ROCK FILTER DAM (TY 2)
	ROCK FILTER DAM (TY 3)
	DIRECTION OF FLOW

- NOTES:
- ① START SEDIMENT CONTROL AT LOCATION SO ALL STORM WATER WITH SEDIMENT IS COLLECTED
  - ② ROCK FILTER DAMS OR EARTH/GRASSED EMBANKMENTS CAN BE SUBSTITUTED AS DIRECTED.
  - ③ PROVIDE A SMOOTH TRANSITION FROM THE INVERT ELEVATIONS BETWEEN CULVERTS. REMOVE LOOSE SOIL FROM EXCAVATED AREA BETWEEN CULVERTS.
  - ④ PROVIDE AND INSTALL PNEUMATICALLY PLACED CONCRETE ON THE DITCH BOTTOM AND SIDE SLOPES BETWEEN TEMPORARY TERMINATIONS BETWEEN OLD AND NEW CULVERTS. PNEUMATICALLY PLACED CONCRETE WILL BE PLACED TO THE HEIGHT OF THE LARGEST CULVERT ON THE DITCH SIDE SLOPES; AND TO A LIMIT 10 FEET OUTSIDE THE LOCATION OF BMPS ALONG THE DITCH BOTTOM. CEMENT STABILIZED SAND MAY BE SUBSTITUTED FOR PNEUMATICALLY PLACED CONCRETE, IN AREAS WHERE INSTALLATION WORKS AND AT THE OPTION OF TXDOT.

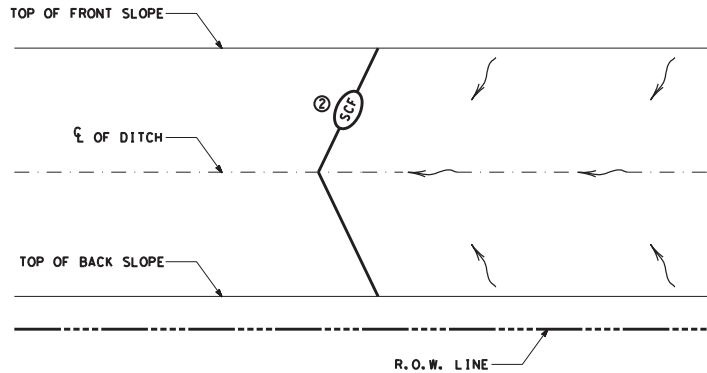

**BEST MANAGEMENT PRACTICE (BMP) #11**  
 BOUNDARY SEDIMENT CONTROL ~ BOTH ENDS OF CONTROL TERMINATED UP SLOPE

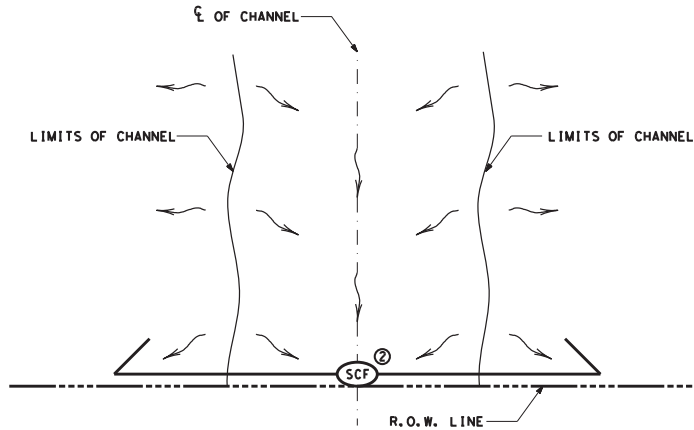

**BEST MANAGEMENT PRACTICE (BMP) #12**  
 BOUNDARY SEDIMENT CONTROL ~ BOTH ENDS OF CONTROL TERMINATED DOWN SLOPE

SCALE = NTS SHEET 7 OF 10



**TYPICAL APPLICATIONS FOR BEST MANAGEMENT PRACTICES**

**TA-BMP**

FILES: BMLAYOUTS.dgn	DN: TXDOT	CR: TXDOT	DR: TXDOT	CK: TXDOT
© TXDOT 2009	CONT	SECT	JOB	HIGHWAY
REVISIONS	6379	46	001	SH 320, ETC
DEC 2013	DIST	COUNTY	WACO	FALLS
FEB 2015				SHEET NO. 66

3/23/2021 9:47:11 AM T:\MAGMA\INT\...RMC\_Contracts\Base\of\Ture\_P\m\m\int\...2022\FALLS\CADD\SHEETS\STANDARDS\TA-BMP-2015\_Layouts.dgn

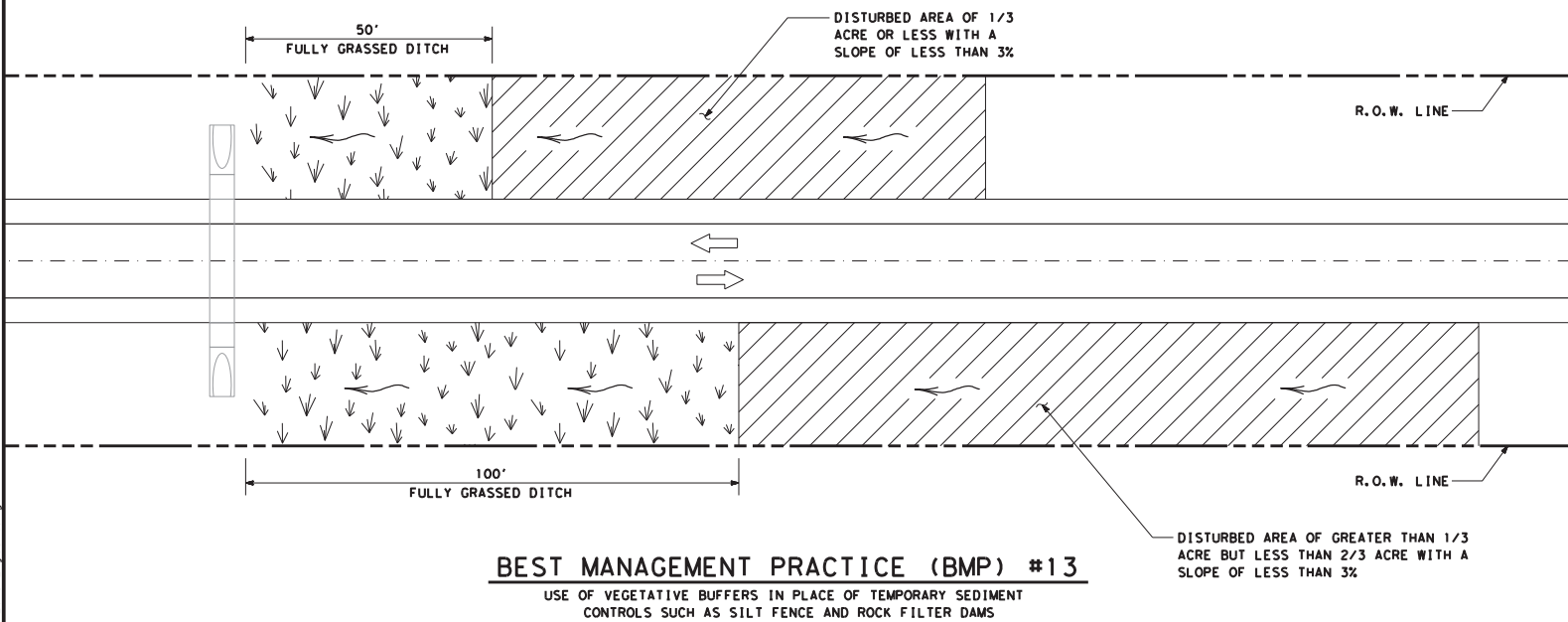

**BEST MANAGEMENT PRACTICE (BMP) #13**

USE OF VEGETATIVE BUFFERS IN PLACE OF TEMPORARY SEDIMENT CONTROLS SUCH AS SILT FENCE AND ROCK FILTER DAMS

	FULLY GRASSED DITCH
	DISTURBED AREA
	DIRECTION OF FLOW
	SEDIMENT CONTROL FENCE

- ① FOR H DIMENSIONS LESS THAN 1.5' SILT FENCE MAY NEED TO BE NOTCHED AS SHOWN IN VIEW A-A. ADD EXTRA POSTS AT NOTCH.
- ② BMP #14 MAY BE USED AT CROSS DRAINAGE STRUCTURES AS DIRECTED.

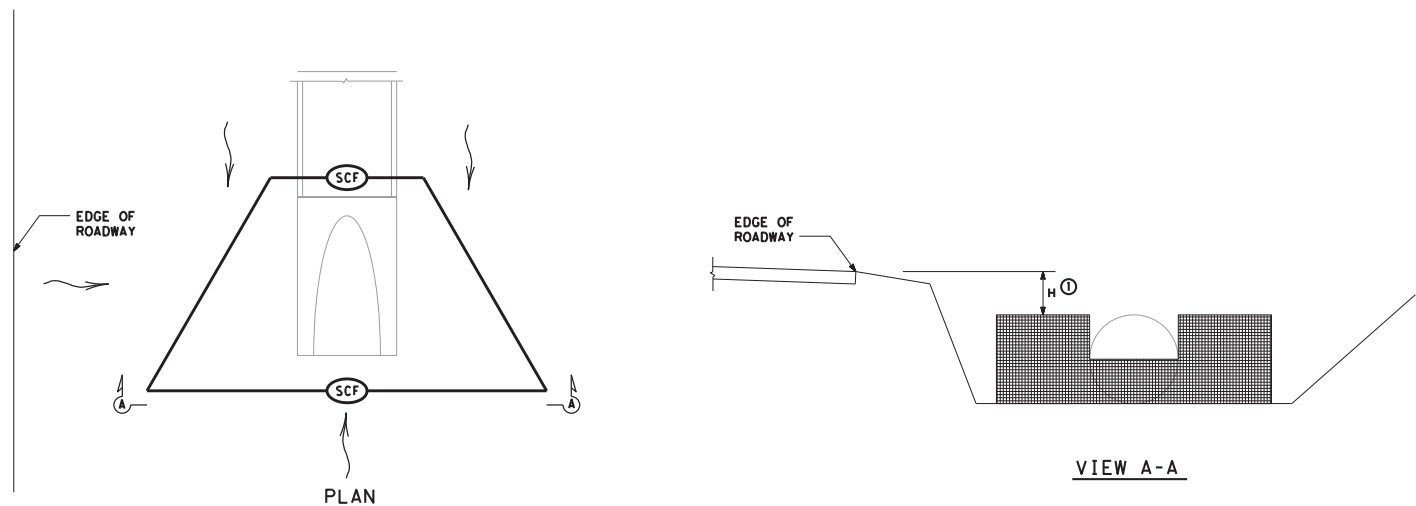

**BEST MANAGEMENT PRACTICE (BMP) #14**

NON-404 STREAMS AND DITCHES ONLY - SEDIMENT CONTROL AT PARALLEL DRAINAGE STRUCTURE ENTRANCE ②

SCALE = NTS SHEET 8 OF 10

**Texas Department of Transportation**  
Waco District Standard

**TYPICAL APPLICATIONS FOR BEST MANAGEMENT PRACTICES**

**TA-BMP**

FILES: BMP\PLAYOUTS.dgn	DN: TXDOT	CR: TXDOT	DR: TXDOT	CK: TXDOT
© TXDOT 2009	CONT	SECT	JOB	HIGHWAY
REVISIONS	6379	46	001	SH 320, ETC
DEC 2013	BIST	COUNTY	SHEET NO.	
FEB 2015	WACO	FALLS	67	

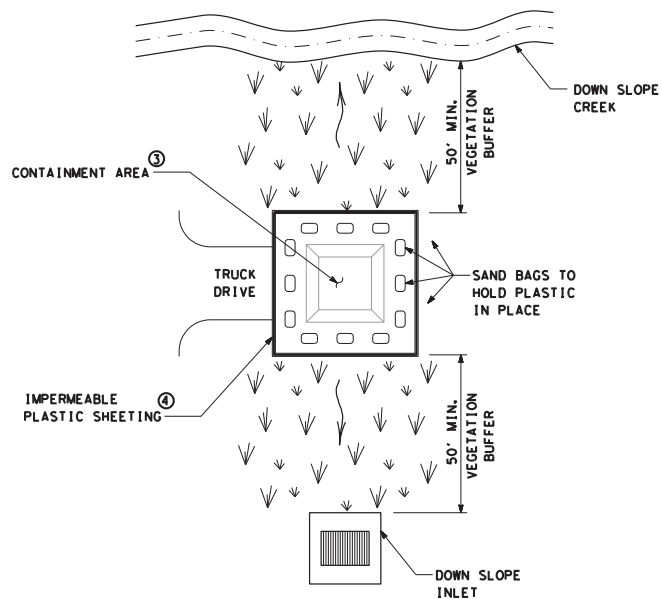

**BEST MANAGEMENT PRACTICE (BMP) #15**  
CONCRETE TRUCK WASHOUT AREA

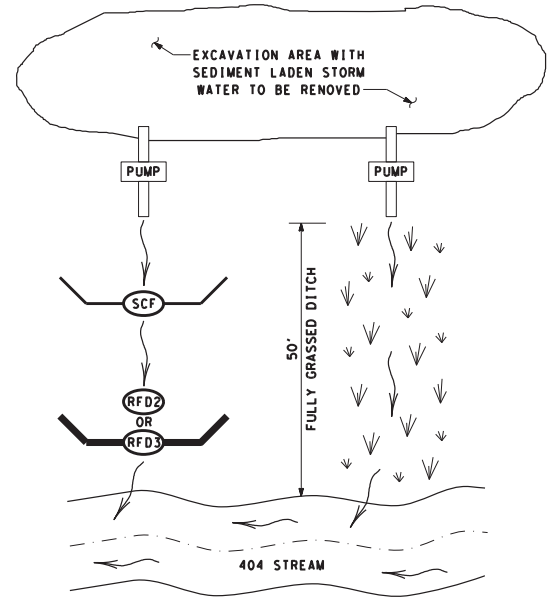

**BEST MANAGEMENT PRACTICE (BMP) #16**  
PUMPED STORM WATER SEDIMENT CONTROLS ①

	FULLY GRASSED DITCH
	DIRECTION OF FLOW
	SEDIMENT CONTROL FENCE
	ROCK FILTER DAM (TY 2)
	ROCK FILTER DAM (TY 3)

- ① PUMPED STORM WATER FROM AN EXCAVATION AREA SHOULD BE DISCHARGED IN A 50' VEGETATIVE BARRIER OR THROUGH TWO TEMPORARY SEDIMENT CONTROLS BEFORE ENTERING A 404 STREAM.
- ② FOR LANDOWNER STOCKPONDS WITHIN 50' OF THE RIGHT OF WAY LINE, PROVIDE REDUNDANT SEDIMENT CONTROLS AT THE CONVEYANCE OF THE POND. MINIMUM OF TWO SEDIMENT CONTROLS.
- ③ WHEN CONTAINMENT AREA REACHES 1' FREEBOARD, DISCONTINUE WASHOUT PLACEMENT AND REMOVE MATERIAL UPON SOLIDIFICATION.
- ④ EACH TIME SOLIDIFIED MATERIAL IS REMOVED REPLACE PLASTIC SHEETING.

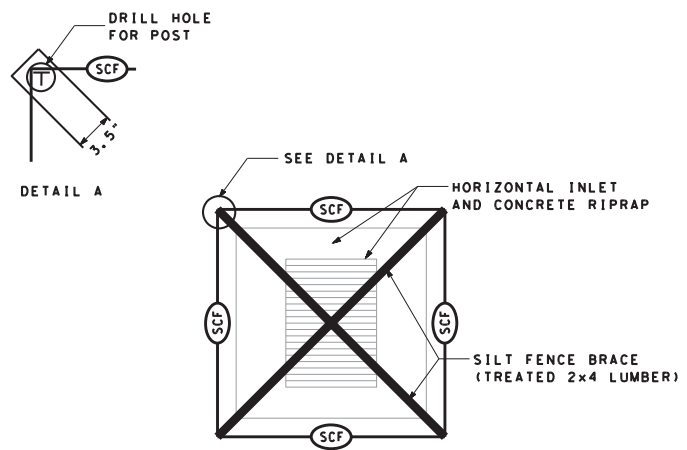

**BEST MANAGEMENT PRACTICE (BMP) #17**  
HORIZONTAL INLET SEDIMENT CONTROL

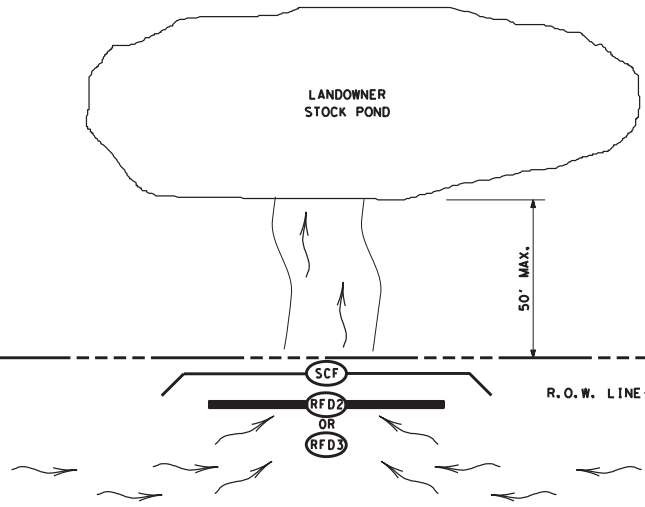

**BEST MANAGEMENT PRACTICE (BMP) #18**  
LANDOWNER STOCKPOND SEDIMENT CONTROL ②

SCALE = NTS SHEET 9 OF 10

**Texas Department of Transportation**  
Waco District Standard

**TYPICAL APPLICATIONS FOR BEST MANAGEMENT PRACTICES**

**TA-BMP**

FILES: BMLAYOUTS.dgn	DN: TXDOT	CR: TXDOT	DR: TXDOT	CR: TXDOT
© TXDOT 2009	CONT	SECT	JOB	HIGHWAY
REVISIONS	6379	46	001	SH 320, ETC
DEC 2013	BIST	COUNTY	WACO	FALLS
FEB 2015				SHEET NO. 68

3/23/2021 9:47:11 AM T:\MAGMINT\...RMC\_Contract\...Base\G1\ure\_P\m\g\int\h\y-2022\FALLS\GADD\SHEETS\STANDARDS\TA-BMP-2015\_Layouts.dgn



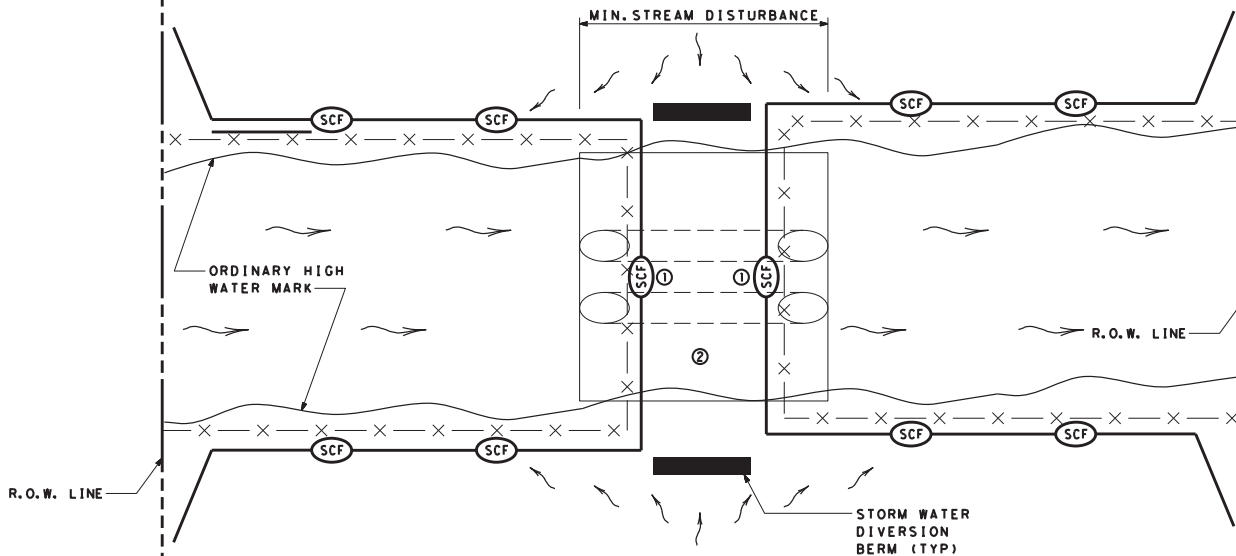

**BEST MANAGEMENT PRACTICE (BMP) #19**  
TYPICAL 404 STREAM CROSSING (SEDIMENT CONTROL AT CROSSING)

	DIRECTION OF FLOW
	SEDIMENT CONTROL FENCE
	ROCK FILTER DAM
	SECURITY FENCING

- ① HAY BALES MAY BE SUBSTITUTED FOR SILT FENCE OVER THE STREAM CROSSING.
- ② CROSSING WILL BE AS PER REQUIREMENTS OF THE WATERS OF THE US GENERAL NOTES.
- ③ INSTALL SILT FENCE SLIGHTLY UP FROM OHW MARK FROM R.O.W. TO R.O.W.
- ④ USE SILT FENCE L-HOOKS ON LEVEL OR DOWN SLOPING ENDS TO BLOCK STORM WATER SEDIMENT
- ⑤ INSTALL LARGE V OR U SHAPED BMP'S FROM ABUTMENT AS SHOWN. IF THERE IS STEEP DITCH CONDITIONS DECREASE SPACING AND CONSIDER RFD'S. ADD ADDITIONAL BMP'S IF GRADE IS STEEP OR IF FLOW IS HIGH.

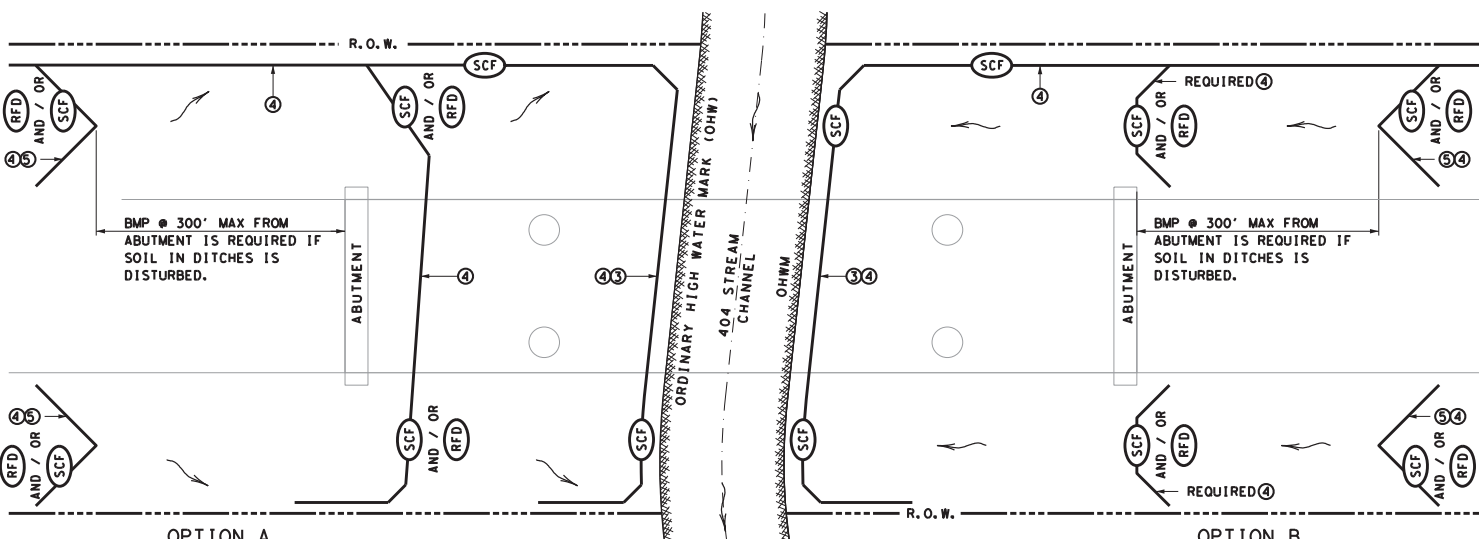

**BEST MANAGEMENT PRACTICE (BMP) #20**  
FOR 404 STREAMS ~ BMP'S AT BRIDGES

SCALE = NTS SHEET 10 OF 10

**Texas Department of Transportation**  
Waco District Standard  
**TYPICAL APPLICATIONS FOR BEST MANAGEMENT PRACTICES**

**TA-BMP**

FILES: BMLAYOUTS.dgn	DN: TXDOT	CR: TXDOT	DN: TXDOT	CR: TXDOT
© TXDOT 2009	CONT: 6379	SECT: 46	JOB: 001	HIGHWAY: SH 320, ETC
REVISIONS	BIST: WACO	COUNTY: FALLS	SHEET NO. 69	

3/23/2021 9:47:12 AM T:\MAGM\INT\...\_RMC\_Contractors\Base\g1\ure\_Pvm\g1\nt\FY-2022\FALLS\CADD\SHEETS\STANDARDS\TA-BMP-2015\_Layouts.dgn