

FINAL PLANS

NAME OF CONTRACTOR: _____
 DATE OF LETTING: _____
 DATE WORK BEGAN: _____
 DATE WORK COMPLETED: _____
 DATE WORK ACCEPTED: _____
 SUMMARY OF CHANGE ORDERS:

STATE OF TEXAS
 DEPARTMENT OF TRANSPORTATION

PLANS OF PROPOSED
 STATE HIGHWAY IMPROVEMENT

STATE PROJECT
 C 95 14 33
 CSJ: 0095-14-033, ETC

IH 20, ETC.
 KAUFMAN, ETC. COUNTY

DESIGN BLS	FED. RD. DIV. NO. 6	STATE PROJECT NO. C 95-14-33		HIGHWAY NO. IH 20, ETC.
GRAPHICS IJ	STATE	DISTRICT	COUNTY	SHEET NO. 1
CHECK BLS	TEXAS	DALLAS	KAUFMAN, ETC.	
CHECK BA	CONTROL 0095	SECTION 14	JOB 033, ETC	

LIMITS: FROM TARRANT-DALLAS COUNTY LINE
 TO KAUFMAN-VAN ZANDT COUNTY LINE

TOTAL LENGTH OF PROJECT = ROADWAY = NA FT. = NA MI.
 BRIDGE = NA FT. = NA MI.
 TOTAL = NA FT. = NA MI.

TYPE OF WORK: FOR THE CONSTRUCTION OF INSTALL GUIDE SIGNS
 CONSISTING OF: SIGN REMOVAL, REPLACEMENT, AND INSTALLATION.

NOTE:

SPECIFICATIONS ADOPTED BY THE TEXAS DEPARTMENT OF TRANSPORTATION, NOVEMBER 1, 2014, AND THE CONTRACT PROVISIONS LISTED AND DATED AS FOLLOWS SHALL GOVERN ON THIS PROJECT: SPECIAL LABOR PROVISIONS FOR STATE PROJECTS (000-008)

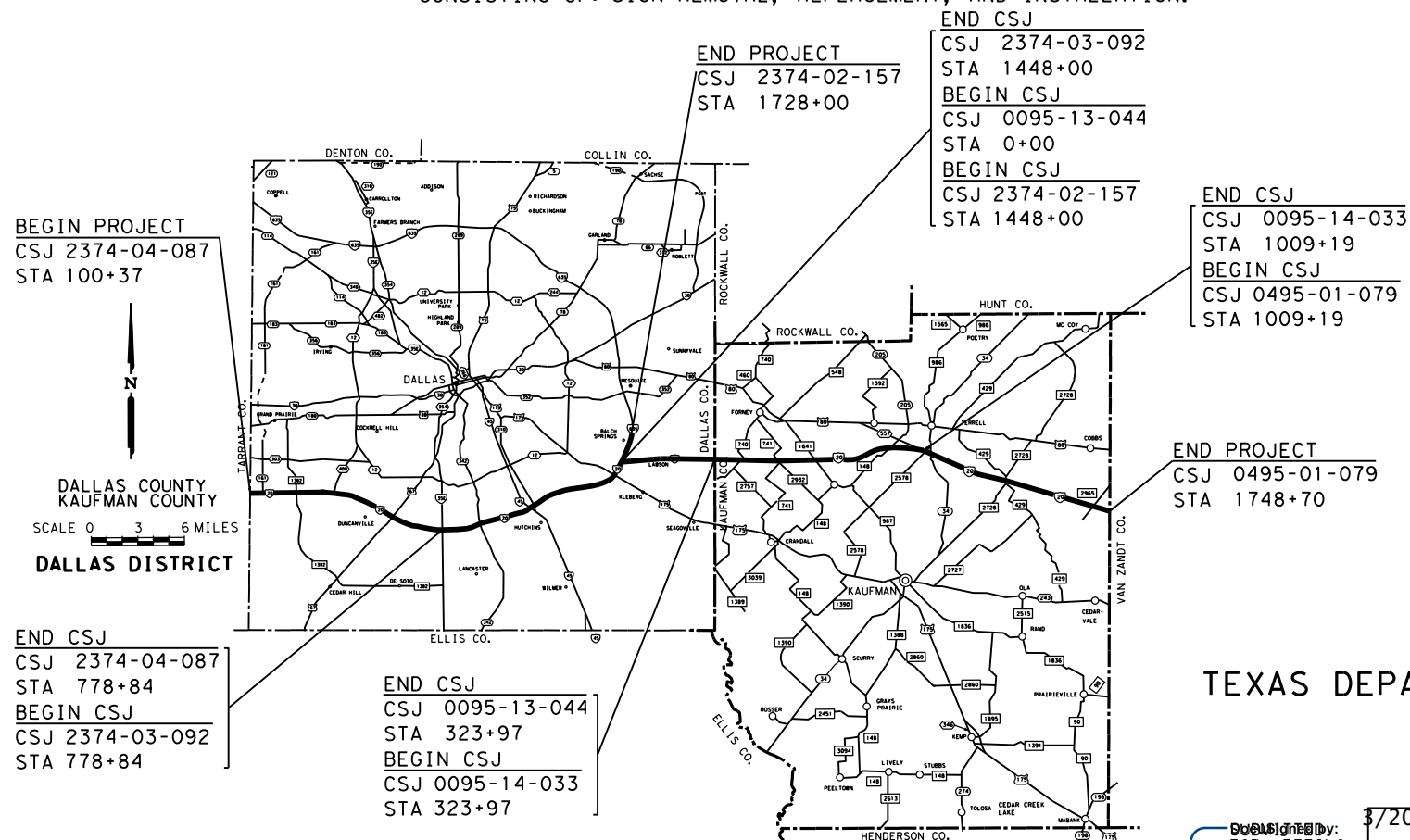

DALLAS COUNTY
 KAUFMAN COUNTY
 SCALE 0 3 6 MILES
 DALLAS DISTRICT

TEXAS DEPARTMENT OF TRANSPORTATION

WORK WAS COMPLETED ACCORDING
 TO THE PLANS AND CONTRACT.
 _____, P.E.
 Signature of Registrant & Date

EQUATIONS: IH 20 STA 1448+00 = IH 20 STA 0+00
 EXCEPTIONS: NONE
 RAILROAD CROSSINGS: NONE

RECOMMENDED FOR LETTING 3/20/2023
 20
 Brandi A. Green, P.E.
 TRAFFIC ENGINEERING SUPERVISOR

RECOMMENDED FOR LETTING 3/21/2023
 20
 Jeffrey Bush, P.E.
 DIRECTOR OF OPERATIONS

RECOMMENDED FOR LETTING 3/20/2023
 20
 Brandi A. Bush, P.E.
 DISTRICT TRANSPORTATION OPERATIONS ENGINEER

APPROVED FOR LETTING 3/21/2023
 20
 Casson Clemens, P.E.
 DISTRICT ENGINEER

INDEX OF SHEETS

\$DATE\$

\$DATE\$

\$FILE\$

SHEET DESCRIPTION

I. GENERAL

1 TITLE SHEET
 2 INDEX OF SHEETS
 3-3C GENERAL NOTES
 4-4A ESTIMATE AND QUANTITY SHEETS
 5-7 PROJECT SUMMARY
 8-42 SUMMARY OF LARGE SIGNS
 43-77 SUMMARY OF SMALL SIGNS

II. TRAFFIC CONTROL PLAN

78-89 * BC (1)-21 THRU BC (12)-21
 90 * TCP (1-5)-18
 91 * TCP (2-6)-18
 92 * TCP (2-8)-18
 93-97 * TCP (6-1)-18 THRU TCP (6-5)-12
 98 * TCP (6-8)-14

III. ROADWAY DETAILS

99 * GF(31)-19
 100 * GF(31)DAT-19
 101 * SGT(12S)31-18

IV. RETAINING WALL DETAILS

NONE

SHEET DESCRIPTION

V. DRAINAGE DETAILS

NONE

VI. UTILITIES

NONE

VII. BRIDGES

102-104 BMCSSSTE(1)-19 THRU BMCSSSTE(3)-19

SHEET DESCRIPTION

VIII. TRAFFIC ITEMS

105-225 SIGNING LAYOUTS
 226-272 GUIDE SIGN DETAILS
 273 OVERHEAD SIGN STRUCTURE DETAILS
 274-278 * TSR (1)-13 THRU TSR (5)-13
 279-281 * D&OM (1)-20 THRU D&OM (3)-20
 282 * D&OM (6)-20
 283 * SMD(GEN)-08
 284 * SMD(SLIP-1)-08 (DAL)
 285 * SMD(SLIP-2)-08
 286 * SMD(SLIP-3)-08
 287-290 * SMD (2-1)-08 THRU SMD (2-4)-08
 291 * SMD (2-6)-01
 292 * SMD (TY G)-08
 293-294 * SMD (8W1)-08 THRU SMD (8W2)-08
 295 * WV & IZ-14
 296 * COSS-Z4&Z4I-10
 297-298 * COSSD
 299 * COSSF-21
 300 * COSS-FD
 301-302 * SB(SWL-1)-14

IX. ENVIRONMENTAL ISSUE

303 ENVIRONMENTAL PERMITS, ISSUES, AND COMMITMENTS(EPIC)
 304 STORM WATER POLLUTION PREVENTION PLAN (SW3P)

X. MISCELLANEOUS ITEMS

NONE



Brenda L Sanchez, P.E. 03/20/23
 Signature of Registrar & Date



INDEX OF SHEETS

SCALE: NTS SHEET 1 OF 1

DESIGN/CK	FED. RD. DIV. NO.	STATE PROJECT NO.		HIGHWAY NO.
BLS	6	(SEE TITLE SHEET)		IH0020
BLS	STATE	DISTRICT	COUNTY	SHEET NO.
CHECK	TEXAS	DALLAS	VARIOUS	2
CHECK	CONTROL	SECTION	JOB	
	0095	14	033, ETC	

CSJ: 0095-14-033, etc.

County: Kaufman, etc.

Highway: IH 20, etc.

General:

The construction, operation and maintenance of the proposed project will be consistent with the state implementation plan as prepared by the Texas Commission on Environmental Quality.

The disturbed area for this project, as shown on the plans is 0.0008 acres per sign structure installed. However, the Total Disturbed Area (TDA) will establish the required authorization for storm water discharges. The TDA of this project will be determined by the sum of the disturbed area in all project locations in the contract, and all disturbed area on all Project-Specific Locations (PSL) located in the project limits and/or within 1 mile of the project limits. The department will obtain an authorization to discharge storm water from the Texas Commission on Environmental Quality (TCEQ) for the construction site as shown on the plans, according to the TDA of the project. The contractor will obtain any required authorization from the TCEQ for the discharge of storm water from any PSL for construction support activities on or off the project row according to the TDA of the project. When the TDA for the project exceeds 1 acre, provide a copy of the appropriate application of permit (NOI, or Construction Site Notice) to the engineer, for any PSL located in the project limits or within 1 mile of the project limits. Follow the directives and adhere to all requirements set forth in the TCEQ, Texas Pollution Discharge Elimination System, Construction General Permit (TPDES, CGP).

Leave all right of way areas undisturbed until actual construction is to be performed in said areas.

Locate all utilities, both underground and above ground, in the project area prior to beginning work so that conflicts are avoided.

Use established industry and utility safety practices to erect poles, luminaries, signs or structures near any overhead or underground utility. Consult with the appropriate utility company prior to beginning such work.

Clean the location of all excess dirt and rubbish upon completion of the work, or as directed. Restore public and private property damaged during the prosecution of the work to an acceptable condition. Leave the work site in a neat and presentable condition throughout the duration of the contract.

Provide the Engineer with a copy of all DBE subcontractor agreements prior to commencing work.

Questions may be submitted via the Letting Pre-Bid Q&A web page. This webpage can be accessed from the Notice to Contractors dashboard located at the following Address: <https://tableau.txdot.gov/views/ProjectInformationDashboard/NoticetoContractors>

Contractor questions on this project are to be emailed to the following individual(s):

Engineer's Email: Christopher.Blain@txdot.gov

Construction Manager's Email: Eric.Herman@txdot.gov

Construction Record-Keeper's Email: Anthony.Block@txdot.gov

CSJ: 0095-14-033, etc.

Sheet: 3

County: Kaufman, etc.

Highway: IH 20, etc.

All contractor questions will be reviewed by the Engineer or Construction Manager. All questions and any corresponding responses that are generated will be posted through the same Letting Pre-Bid Q&A web page.

The Letting Pre-Bid Q&A web page for each project can be accessed by using the dashboard to navigate to the project you are interested in by scrolling or filtering the dashboard using the controls on the left. Hover over the blue hyperlink for the project you want to view the Q&A for and click on the link in the window that pops up.

Fulfillment of the requirements stated above is subsidiary to the various bid items.

Item 5:

Ensure a representative of the Prime Contractor is available on the project at all times when work is being performed by the Prime Contractor or sub-contractor(s) to receive instructions from the Engineer or authorized Department representative.

Underground utilities owned by the Texas Department of Transportation may be present within the Right-Of-Way on this project. For signal, illumination, surveillance, and communications & control maintained by TxDOT, call the TxDOT Traffic Signal Office (214-320-6682) for locates a minimum of 48 hours in advance of excavation. For irrigation systems, call TxDOT Maintenance Landscape Office (214-320-6205) for locates a minimum of 48 hours in advance of excavation. If city or town owned irrigation facilities are present, call the appropriate department of the local city or town a minimum of 48 hours in advance of excavation. The Contractor is liable for all damages when utilities are damaged due to Contractor's negligence including, but not limited to, repair or replacement at the Contractor's expense.

For the project to be deemed complete, permanently stabilize all unpaved disturbed areas of the project with a vegetative cover at a minimum of 70% density for the control of erosion.

Submit all shop drawings, working drawings, or other documents which require review sufficiently in advance of scheduled construction to allow no less than thirty (30) calendar days for review and response.

Place construction stakes/station markings at intervals of not more than 100 feet or as directed by Engineer. Place stakes and markings so as not to interfere with normal construction operations.

Item 7:

Repair or replace any structures and utilities that might have been damaged by negligence or a failure to have utility locates performed.

Holiday restrictions – the engineer may decide that no lane closures or construction operations shall be allowed during the restricted periods listed in the following holiday schedule. TxDOT has the right to lengthen, shorten, or otherwise modify these restricted periods as actual, or expected, traffic conditions may warrant. Working days will not be charged for these restricted periods. No

CSJ: 0095-14-033, etc.

County: Kaufman, etc.

Highway: IH 20, etc.

additional compensation will be allowed for these closures (i.e., overhead, delays, stand-by, barricades or any other associated cost impacts).

- New Year's Eve and Day (noon on December 31 thru 10:00 pm January 1)
- Easter Holiday weekend (noon on Friday thru 10:00 pm Sunday)
- Memorial Day weekend (noon on Friday thru 10:00pm Monday)
- Independence Day (noon on July 3 thru 10:00 pm on July 5)
- Labor Day weekend (noon on Friday thru 10:00 pm Monday)
- Thanksgiving Holiday (noon on Wednesday thru 10:00 pm Sunday)
- Christmas Holiday (noon on December 23 thru 10:00 pm December 26)

No significant traffic generator events identified.

Item 8:

This Project will be a Standard Workweek in accordance with Article 8.3.1.4.

Nighttime work is allowed in accordance with Article 8.3.3.

Meet daily with the Engineer to notify him or her of planned work for the day and to provide 24-hour notice of lane closures for planned work for the next day. Do not close lanes for which this requirement is not met. No work is to be performed without prior coordination with the Engineer.

The Lane Closure Assessment Fee is show on the following table. The fee applies to the Contractor for closures or obstructions that overlap into restricted hour traffic for each hour or portion thereof, per lane, regardless of the length of the lane closure of obstruction.

Roadway	Amount Per Lane Per Hour
IH 20 (Dallas County)	\$4,000
IH 20 (Kaufman County)	\$1,100
IH 635	\$4,500

A 120 day construction delay is included in this contract through Special Provision 008-004. This delay is included for material acquisition.

Item 104 – Removing Concrete:

Sawing of concrete is not paid for directly but is considered subsidiary to this item.

Removal of concrete foundations including steel shall be at full length for small and large sign assemblies, unless otherwise shown on the plans.

Item 416:

CSJ: 0095-14-033, etc.

Sheet: 3A

County: Kaufman, etc.

Highway: IH 20, etc.

Extend drilled shaft foundations for overhead sign structures five feet into rock at locations where rock is encountered at a depth less than the drilled shaft lengths shown in the plans.

Drilled shafts 12" or larger shall be formed from 2" below existing grade to the top of the foundation with sonotube or other approved methods. All portions of drilled shafts extending above grade shall be formed and have a smooth finish. Include cost for this work in the unit bid price for this item.

Base all drilled shaft foundations for overhead sign structures on the lengths shown on the plans or as approved in writing. Make calculations for measurement of foundations in accordance with Article 9.1 of the standard specifications. Measure increase or decreases in the quantities required by change in design as specified and the revised quantities will be the basis for payment.

Use concrete classified as "miscellaneous concrete" for ground mounted sign foundations, with the exception of large roadside signs and overhead sign structures.

Payment will be made only once for drilling the shaft regardless of the extra work caused by obstructions.

Item 421:

Furnish mix designs to the Engineer in a format compatible to the latest version of the Department's Construction Management System (SiteManager). Mix Design templates will be provided by the Engineer.

Provide sulfate resistant concrete for all drilled shafts. At the contractor's option, a sulfate resistant high-performance concrete may be used; however, high performance concrete is not considered sulfate resistant concrete when Class C fly ash and Type I cement is used in the mix design.

Provide all freshly mixed concrete testing equipment as required by subsection 3.3, except as noted here. Curing facilities, maturity meters, and strength-testing equipment will not be required. Air content testing is waived for this project. All testing equipment shall be clean and in like-new condition. Test molds shall be 4" diameter x 8" tall.

Item 500:

Material On Hand (MOH) will not be used in calculating partial payments for Mobilization.

Item 502:

Access will be provided to all business and residences at all times. Materials, labor and maintenance for these temporary accesses will not be paid for directly but will be considered subsidiary to the various bid items.

CSJ: 0095-14-033, etc.

County: Kaufman, etc.

Highway: IH 20, etc.

Place barricades and signs in locations that do not obstruct the sight distance of drivers entering the highway from driveways or side streets.

When moving unlicensed equipment on or across any pavement or public highways, protect the pavement from all damage using an acceptable method.

Limit lane closures along IH 20 & IH 635 to the hours between 9:00 am and 3:30 pm and 9:00 pm to 5:30 am. Work in other areas of the project is not restricted to this time frame.

The Contractor Force Account "Safety Contingency" that has been established for this project is intended to be utilized for work zone enhancements, to improve the effectiveness of the Traffic Control Plan, that could not be foreseen in the project planning and design stage. These enhancements will be mutually agreed upon by the Engineer and the Contractor's Responsible Person based on weekly or more frequent traffic management reviews on the project. The Engineer may choose to use existing bid items if it does not slow the implementation of enhancement.

Item 506

The Storm Water Pollution Prevention Plan (SW3P) consists of using the following items as directed:

- Biodegradable Erosion Control Logs

This work will be paid for under the respective bid item.

This in no way releases the contractor of liability for noncompliance.

Item 540:

Furnish one type of post throughout the project except as specifically noted in the plans.

Item 636:

Leave the advance guide sign and/or the exit direction sign for an interchange in place at all times unless prior written approval is given. Replace signs removed by the Contractor before the end of the workday.

Manufacture all white legends using Clearview font on overhead and large ground-mounted guide signs. This includes destinations, cardinal directions, exit information and exit numbers. Use the font shown on the current standard sheets for all route markers (including interstate shields) and "Exit Only" panel information. Letter, arrow, and number heights shall all conform to the latest edition of the Standard Highway Sign Design Manual.

Provide two (2) sets of shop drawings for signs. The shop drawings shall conform to the details shown on the plans. The shop drawings shall show the details of the panels, wind beams, stiffeners, joint backing plates, splices, fasteners, brackets, and sign support connections. The shop drawings shall show letter types and sizes, interline spacing and message arrangements.

CSJ: 0095-14-033, etc.

Sheet: 3B

County: Kaufman, etc.

Highway: IH 20, etc.

Affix a sign identification decal to the back of all signs and mark out the installation date in accordance with Item 643.

Attach sheeting applied to extruded aluminum panels to each individual extrusion.

All new and or replaced sign panels shall be mounted flush (0°) on all sign structures. Furnish and obtain approval of all shop drawings detailing the method to accomplish this installation. All material and labor required for this special installation is considered subsidiary to Item 636.

Ensure the minimum vertical clearance, as shown in the plans, at the highpoint of the roadway after the installation of all overhead signs. Mount new overhead signs with 46% of the sign height positioned below the centerline of the truss. If new signs are mounted on a truss with existing signs, all signs shall be bottom justified using the 46% of the tallest sign to determine placement.

Place new guide signs on existing overhead sign structures and bridge rail supports. Existing attachment hardware may be reused if position of sign meets the 46% mounting criteria and if the existing hardware is large enough to accommodate the new sign. Sign support brackets may be cut or removed as directed; however, do not extend or lengthen existing brackets. Furnish any additional sign attachment hardware, support brackets, etc. as required. Payment will not be made for the additional brackets but is considered subsidiary to this Item.

All additional hat signs and plaques mounted to the top of signs shall be supported with wind beams 2.5 times the height of the sign and/or plaque.

Items 644, 647, and 650:

Prior to taking elevations to determine lengths for fabrication of signposts and/or sign support towers, obtain verification of all proposed locations.

All sign mounts shall have a clamp base system for all small roadside sign assemblies.

The post lengths shown on the Summary of Large Signs are approximations only. After the "X" dimensions are determined, submit actual post lengths to the Engineer for approval. Post lengths and size shall be approved by the Engineer before fabrication.

Torque the anchor bolts for only the Exit Gore signs to 60 foot-pounds.

Removal of concrete foundations including steel shall be at full length for small and large sign assemblies, unless otherwise shown on the plans.

Item 650:

All towers and trusses will be match marked, by the fabricator, for erection. Use the tower heights shown in the sign summaries and on the plans for bidding purposes only. Prior to fabrication, take finished grade elevations at the tower locations and determine their exact heights for fabrication in accordance with the details shown on the plans.

CSJ: 0095-14-033, etc.

County: Kaufman, etc.

Highway: IH 20, etc.

Item 654:

Sign lights on walkways will be considered as various components of the walkway and will therefore be subsidiary to the removal of the walkways.

Item 658:

Provide a flat mount delineator for guard fence attachment meeting the following requirements. 33 in. in length and be flattened and sealed on each end enabling mounting height to be consistent without the use of a tape measure. Post will be a minimum of 2-3/8 in. outside diameter composed of recycled tire rubber and post-consumer materials. Post will be permanently sealed at the top and be a minimum of 3 in. wide and capable of displaying a 3-in. wide by 12 in. long piece of reflective sheeting.

Item 6185:

The total number of truck mounted attenuators (TMA) required when utilizing the traffic control standards are shown in the tables below.

TCP 1 Series	Scenario	Required TMA
(1-5)-12		1

TCP 2 Series	Scenario	Required TMA
(2-6)-12	All	1

TCP 6 Series	Scenario	Required TMA
(6-1)-12	A	1
	B	2
(6-2)-12	All	1
(6-3)-12	All	1
(6-4)-12	A	1
	B	2
(6-5)-12	A	1
	B	2
(6-8)-14	All	1

Shadow vehicles equipped for truck mounted attenuators (TMA) for stationary operations will be paid for by the each and must be available for use at any time as determined by the Engineer.

CSJ: 0095-14-033, etc.

Sheet: 3C

County: Kaufman, etc.

Highway: IH 20, etc.

Mobile operations will be paid for by the hour, per specifications. For mobile operations, payment will be made only while the TMA is in use.

Therefore, 412 total shadow vehicles with TMA will be required for this type of work. The contractor will be responsible for determining if one or more of these operations will be ongoing at the same time to determine the total number of TMA needed for the project.



Estimate & Quantity Sheet

CONTROLLING PROJECT ID 0095-14-033

DISTRICT Dallas
HIGHWAY IH 20, IH 635

COUNTY Dallas, Kaufman

CONTROL SECTION JOB				0095-13-044		0095-14-033		0495-01-079		2374-02-157		2374-03-092		2374-04-087	
PROJECT ID				A00066934		A00066935		A00066947		A00066983		A00066986		A00066988	
COUNTY				Dallas		Kaufman		Kaufman		Dallas		Dallas		Dallas	
HIGHWAY				IH 20		IH 20		IH 20		IH 635		IH 20		IH 20	
ALT	BID CODE	DESCRIPTION	UNIT	EST.	FINAL	EST.	FINAL	EST.	FINAL	EST.	FINAL	EST.	FINAL	EST.	FINAL
	104-6013	REMOVING CONC (FOUNDATIONS)	SY			0.980								5.250	
	416-6018	DRILL SHAFT (SIGN MTS) (24 IN)	LF			115.000		181.000						16.500	
	416-6022	DRILL SHAFT (SIGN MTS) (48 IN)	LF											16.000	
	432-6045	RIPRAP (MOW STRIP)(4 IN)	CY											13.700	
	500-6001	MOBILIZATION	LS	0.094		0.111		0.148		0.099		0.233		0.315	
	502-6001	BARRICADES, SIGNS AND TRAFFIC HANDLING	MO			20.000									
	506-6040	BIODEG EROSN CONT LOGS (INSTL) (8")	LF			20.000									
	506-6043	BIODEG EROSN CONT LOGS (REMOVE)	LF			20.000									
	540-6002	MTL W-BEAM GD FEN (STEEL POST)	LF											175.000	
	540-6016	DOWNSTREAM ANCHOR TERMINAL SECTION	EA											1.000	
	544-6001	GUARDRAIL END TREATMENT (INSTALL)	EA											1.000	
	636-6001	ALUMINUM SIGNS (TY A)	SF	35.250				40.250				45.250		57.000	
	636-6002	ALUMINUM SIGNS (TY G)	SF			1,235.000		2,476.750				136.750		242.500	
	636-6003	ALUMINUM SIGNS (TY O)	SF											127.250	
	636-6007	REPLACE EXISTING ALUMINUM SIGNS(TY A)	SF	286.250		663.000		609.000		369.250		471.400		439.250	
	636-6008	REPLACE EXISTING ALUMINUM SIGNS(TY G)	SF	830.250		172.750		85.000		748.750		1,022.250		1,716.500	
	636-6009	REPLACE EXISTING ALUMINUM SIGNS(TY O)	SF	3,466.500		826.250		571.000		4,019.500		10,549.000		10,419.250	
	644-6001	IN SM RD SN SUP&AM TY10BWG(1)SA(P)	EA					2.000							
	644-6004	IN SM RD SN SUP&AM TY10BWG(1)SA(T)	EA	1.000						1.000		2.000		1.000	
	644-6005	IN SM RD SN SUP&AM TY10BWG(1)SA(T-2EXT)	EA					1.000							
	644-6036	IN SM RD SN SUP&AM TYS80(1)SA(U-BM)	EA	1.000				1.000				1.000		2.000	
	644-6051	IN SM RD SN SUP&AM TYS80(2)SA(P-EXAL)	EA			11.000		11.000				3.000		1.000	
	644-6064	IN BRIDGE MNT CLEARANCE SGN ASSM(TY N)	EA	8.000						4.000		2.000		16.000	
	644-6076	REMOVE SM RD SN SUP&AM	EA	1.000		11.000		12.000		1.000		6.000		4.000	
	647-6001	INSTALL LRSS (STRUCT STEEL)	LB			5,501.000		8,459.000						704.000	
	647-6003	REMOVE LRSA	EA	1.000		11.000		15.000						1.000	
	650-6038	INS OH SN SUP(35 FT CANT)	EA											1.000	
	650-6204	REMOVE OVERHD SIGN SUP	EA											1.000	
	654-6007	REMOVE SIGN WALKWAY	EA							1.000					
	658-6061	INSTL DEL ASSM (D-SW)SZ 1(BRF)GF2	EA											3.000	
	6185-6002	TMA (STATIONARY)	DAY	49.000		54.000		55.000		47.000		101.000		106.000	
18		LAW ENFORCEMENT: CONTRACTOR FORCE ACCOUNT WORK (PARTICIPATING)	LS			1.000									
		EROSION CONTROL MAINTENANCE: CONTRACTOR FORCE ACCOUNT WORK (PART)	LS			1.000									
		SAFETY CONTINGENCY: CONTRACTOR FORCE ACCOUNT WORK (PARTICIPATING)	LS			1.000									



CONTROLLING PROJECT ID 0095-14-033

DISTRICT Dallas
HIGHWAY IH 20, IH 635

Estimate & Quantity Sheet

COUNTY Dallas, Kaufman

CONTROL SECTION JOB				TOTAL EST.	TOTAL FINAL
PROJECT ID					
COUNTY					
HIGHWAY					
ALT	BID CODE	DESCRIPTION	UNIT		
	104-6013	REMOVING CONC (FOUNDATIONS)	SY	6.230	
	416-6018	DRILL SHAFT (SIGN MTS) (24 IN)	LF	312.500	
	416-6022	DRILL SHAFT (SIGN MTS) (48 IN)	LF	16.000	
	432-6045	RIPRAP (MOW STRIP)(4 IN)	CY	13.700	
	500-6001	MOBILIZATION	LS	1.000	
	502-6001	BARRICADES, SIGNS AND TRAFFIC HANDLING	MO	20.000	
	506-6040	BIODEG EROSN CONT LOGS (INSTL) (8")	LF	20.000	
	506-6043	BIODEG EROSN CONT LOGS (REMOVE)	LF	20.000	
	540-6002	MTL W-BEAM GD FEN (STEEL POST)	LF	175.000	
	540-6016	DOWNSTREAM ANCHOR TERMINAL SECTION	EA	1.000	
	544-6001	GUARDRAIL END TREATMENT (INSTALL)	EA	1.000	
	636-6001	ALUMINUM SIGNS (TY A)	SF	177.750	
	636-6002	ALUMINUM SIGNS (TY G)	SF	4,091.000	
	636-6003	ALUMINUM SIGNS (TY O)	SF	127.250	
	636-6007	REPLACE EXISTING ALUMINUM SIGNS(TY A)	SF	2,838.150	
	636-6008	REPLACE EXISTING ALUMINUM SIGNS(TY G)	SF	4,575.500	
	636-6009	REPLACE EXISTING ALUMINUM SIGNS(TY O)	SF	29,851.500	
	644-6001	IN SM RD SN SUP&AM TY10BWG(1)SA(P)	EA	2.000	
	644-6004	IN SM RD SN SUP&AM TY10BWG(1)SA(T)	EA	5.000	
	644-6005	IN SM RD SN SUP&AM TY10BWG(1)SA(T-2EXT)	EA	1.000	
	644-6036	IN SM RD SN SUP&AM TYS80(1)SA(U-BM)	EA	5.000	
	644-6051	IN SM RD SN SUP&AM TYS80(2)SA(P-EXAL)	EA	26.000	
	644-6064	IN BRIDGE MNT CLEARANCE SGN ASSM(TY N)	EA	30.000	
	644-6076	REMOVE SM RD SN SUP&AM	EA	35.000	
	647-6001	INSTALL LRSS (STRUCT STEEL)	LB	14,664.000	
	647-6003	REMOVE LRSA	EA	28.000	
	650-6038	INS OH SN SUP(35 FT CANT)	EA	1.000	
	650-6204	REMOVE OVERHD SIGN SUP	EA	1.000	
	654-6007	REMOVE SIGN WALKWAY	EA	1.000	
	658-6061	INSTL DEL ASSM (D-SW)SZ 1(BRF)GF2	EA	3.000	
	6185-6002	TMA (STATIONARY)	DAY	412.000	
18		LAW ENFORCEMENT: CONTRACTOR FORCE ACCOUNT WORK (PARTICIPATING)	LS	1.000	
		EROSION CONTROL MAINTENANCE: CONTRACTOR FORCE ACCOUNT WORK (PART)	LS	1.000	
		SAFETY CONTINGENCY: CONTRACTOR FORCE ACCOUNT WORK (PARTICIPATING)	LS	1.000	

SUMMARY OF SIGNING ITEMS																										
	104 6013	416 6018	416 2022	432 6045	540 6002	540 6016	544 6001	636 6001	636 6002	636 6003	636 6007	636 6008	636 6009	644 6001	644 6004	644 6005	644 6036	644 6051	644 6064	644 6076	647 6001	647 6003	650 6038	650 6204	654 6007	658 6061
	REMOVING CONC (FOUNDATIONS)	DRILL SHAFT (SIGN MTS) (24 IN)	DRILL SHAFT (SIGN MTS)(48 IN)	RIPRAP (MOW STRIP)(4 IN)	MTL W-BEAM GD FEN (STEEL POST)	DOWNSTREAM ANCHOR TERMINAL SECTION	GUARDRAIL END TREATMENT (INSTALL)	ALUMINUM SIGNS (TY A)	ALUMINUM SIGNS (TY G)	ALUMINUM SIGNS (TY O)	REPLACE EXISTING ALUMINUM SIGNS(TY A)	REPLACE EXISTING ALUMINUM SIGNS(TY G)	REPLACE EXISTING ALUMINUM SIGNS(TY O)	IN SM RD SN SUP&AM TY10BWG(1)S A(P)	IN SM RD SN SUP&AM TY10BWG(1)S A(T)	IN SM RD SN SUP&AM TY10BWG(1) SA(T-2EXT)	IN SM RD SN SUP&AM TYS80(1)SA(U-BM)	IN SM RD SN SUP&AM TYS80(2)SA(P-EXAL)	IN BRIDGE MNT CLEARANCE SGN ASSM(TY N)	REMOVE SM RD SN SUP&AM	INSTALL LRSS (STRUCT STEEL)	REMOVE LRSA	INS OH SN SUP(35 FT CANT)	REMOVE OVERHD SIGN SUP	REMOVE SIGN WALKWAY	INSTR DEL ASSM (D-SW)SZ 1(BRF)GF2
	SY	LF	LF	CY	LF	EA	EA	SF	SF	SF	SF	SF	SF	EA	EA	EA	EA	EA	EA	EA	LB	EA	EA	EA	EA	EA
CSJ 0095-13-044																										
Sheet 48 of 121											3.00	72.50	133.00							1						
Sheet 49 of 121											48.50	159.75	533.50							3						
Sheet 50 of 121											8.00	151.50	546.75													
Sheet 51 of 121											54.00	161.50	382.00													
Sheet 52 of 121											14.25	37.50	525.25													
Sheet 53 of 121											28.50	37.50	349.50							2						
Sheet 54 of 121											40.00	37.50	347.50													
Sheet 55 of 121								14			27.50	37.50	305.00									1				
Sheet 56 of 121											35.50															
Sheet 57 of 121											8.00		132.00													
Sheet 58 of 121								21.25					212.00													
Sheet 59 of 121											8.00															
Sheet 60 of 121											11.00	115.00														
CSJ 0095-13-044 TOTALS	0.00	0.00	0.00	0.00	0.00	0.00	0	35.25	0.00	0.00	286.25	830.25	3466.50	0	1	0	1	0	8	1	0	1	0	0	0	0

SUMMARY OF SIGNING ITEMS																										
	104 6013	416 6018	416 2022	432 6045	540 6002	540 6016	544 6001	636 6001	636 6002	636 6003	636 6007	636 6008	636 6009	644 6001	644 6004	644 6005	644 6036	644 6051	644 6064	644 6076	647 6001	647 6003	650 6038	650 6204	654 6007	658 6061
	REMOVING CONC (FOUNDATIONS)	DRILL SHAFT (SIGN MTS) (24 IN)	DRILL SHAFT (SIGN MTS)(48 IN)	RIPRAP (MOW STRIP)(4 IN)	MTL W-BEAM GD FEN (STEEL POST)	DOWNSTREAM ANCHOR TERMINAL SECTION	GUARDRAIL END TREATMENT (INSTALL)	ALUMINUM SIGNS (TY A)	ALUMINUM SIGNS (TY G)	ALUMINUM SIGNS (TY O)	REPLACE EXISTING ALUMINUM SIGNS(TY A)	REPLACE EXISTING ALUMINUM SIGNS(TY G)	REPLACE EXISTING ALUMINUM SIGNS(TY O)	IN SM RD SN SUP&AM TY10BWG(1)S A(P)	IN SM RD SN SUP&AM TY10BWG(1)S A(T)	IN SM RD SN SUP&AM TY10BWG(1) SA(T-2EXT)	IN SM RD SN SUP&AM TYS80(1)SA(U-BM)	IN SM RD SN SUP&AM TYS80(2)SA(P-EXAL)	IN BRIDGE MNT CLEARANCE SGN ASSM(TY N)	REMOVE SM RD SN SUP&AM	INSTALL LRSS (STRUCT STEEL)	REMOVE LRSA	INS OH SN SUP(35 FT CANT)	REMOVE OVERHD SIGN SUP	REMOVE SIGN WALKWAY	INSTR DEL ASSM (D-SW)SZ 1(BRF)GF2
	SY	LF	LF	CY	LF	EA	EA	SF	SF	SF	SF	SF	SF	EA	EA	EA	EA	EA	EA	EA	LB	EA	EA	EA	EA	EA
CSJ 0095-14-033																										
Sheet 60 of 121	0.98										16.50															
Sheet 61 of 121											24.25		168.00													
Sheet 62 of 121											77.00															
Sheet 63 of 121		12.0									8.00															
Sheet 64 of 121											21.25							1			1		730		1	
Sheet 65 of 121											8.00															
Sheet 66 of 121											16.25															
Sheet 67 of 121		10.0									129.5															
Sheet 68 of 121											37.5								1				460		1	
Sheet 69 of 121											48.00															
Sheet 70 of 121		12.0									152															
Sheet 71 of 121		10.0									117.5															
Sheet 72 of 121		10.0									80															
Sheet 73 of 121		11.0									129.5															
Sheet 74 of 121		10.0									8.00															
Sheet 75 of 121											129.5															
Sheet 76 of 121		10.0									80															
Sheet 77 of 121											8.00															
Sheet 78 of 121											8.00															
Sheet 79 of 121											8.00															
Sheet 80 of 121		10.0									80															
Sheet 81 of 121											14.25															
Sheet 82 of 121											25.25		51.75													
Sheet 83 of 121											129.5		83.00		121.00											
Sheet 84 of 121		10.0									17.50															
CSJ 0095-14-033 TOTALS	0.98	115.0	0.0	0.0	0.0	0.0	0	0.0	1235.0	0.0	663.00	172.75	826.25	0	0	0	0	11	0	11	5501	11	0	0	0	0



© 2023

PROJECT SUMMARY

SHEET 2 OF 3

DESIGN/CK	FED. RD. DIV. NO.	STATE PROJECT NO.	HIGHWAY NO.
BLS	6	(SEE TITLE SHEET)	IH 20
CHECK	STATE	DISTRICT	COUNTY
BLS	TEXAS	DAL	VARIOUS
CHECK	CONTROL	SECTION	JOB
MA	0095	14	033, ETC
CHECK	BA		

6

SUMMARY OF SIGNING ITEMS	104	416	416	432	540	540	544	636	636	636	636	636	636	636	644	644	644	644	644	644	647	647	650	650	654	658
	6013	6018	2022	6045	6002	6016	6001	6001	6002	6003	6007	6008	6009	6001	6004	6005	6036	6051	6064	6076	6001	6003	6038	6204	6007	6061
	REMOVING CONC (FOUNDATIONS)	DRILL SHAFT (SIGN MTS) (24 IN)	DRILL SHAFT (SIGN MTS)(48 IN)	RIPRAP (MOW STRIP)(4 IN)	MTL W-BEAM GD FEN (STEEL POST)	DOWNSTREAM ANCHOR TERMINAL SECTION	GUARDRAIL END TREATMENT (INSTALL)	ALUMINUM SIGNS (TY A)	ALUMINUM SIGNS (TY G)	ALUMINUM SIGNS (TY O)	REPLACE EXISTING ALUMINUM SIGNS(TY A)	REPLACE EXISTING ALUMINUM SIGNS(TY G)	REPLACE EXISTING ALUMINUM SIGNS(TY O)	IN SM RD SN SUP&AM TY10BWG(1)S A(P)	IN SM RD SN SUP&AM TY10BWG(1)S A(T)	IN SM RD SN SUP&AM TY10BWG(1)SA(T-2EXT)	IN SM RD SN SUP&AM TY80(1)SA(U-BM)	IN SM RD SN SUP&AM TY80(2)SA(P-EXAL)	IN BRIDGE MNT CLEARANCE SGN ASSM(TY N)	REMOVE SM RD SN SUP&AM	INSTALL LRSS (STRUCT STEEL)	REMOVE LRSA	INS OH SN SUP(35 FT CANT)	REMOVE OVERHD SIGN SUP	REMOVE SIGN WALKWAY	INSTR DEL ASSM (D-SW)SZ 1(BRF)GF2
SY	LF	LF	CY	LF	EA	EA	SF	SF	SF	SF	SF	SF	EA	EA	EA	EA	EA	EA	EA	EA	EA	EA	EA	EA	EA	EA
CSJ 0495-01-079																										
Sheet 85 of 121		22.0						242.00			74.25		278.00					1		1	1026	2				
Sheet 86 of 121											8.00															
Sheet 87 of 121		12.0						213.50			47.00		293.00					1		1	679	1				
Sheet 88 of 121											185.25															
Sheet 89 of 121		12.0						213.50			6.25							1		1	692	1				
Sheet 90 of 121								37.50			25.50							1		1						
Sheet 91 of 121											8.00															
Sheet 92 of 121								89.25						1				2		2						
Sheet 93 of 121											8.00	85.00														
Sheet 94 of 121		10.0						111.00			21.25												348	1		
Sheet 95 of 121		18.0						245.00			8.00											893	1			
Sheet 96 of 121											8.25															
Sheet 97 of 121											67.00															
Sheet 98 of 121		18.0						281.00										1		1	997	1				
Sheet 99 of 121		18.0					12.75	245.00			8.00					1			1	1	1001	1				
Sheet 100 of 121		10.0						95.00														341	1			
Sheet 101 of 121																										
Sheet 102 of 121		10.0						145.00			4.00							1		1	371	1				
Sheet 103 of 121		10.0					7.50	145.00			17.75			1				1		1	353	1				
Sheet 104 of 121																										
Sheet 105 of 121		10.0						95.00			8.00												328	1		
Sheet 106 of 121																										
Sheet 107 of 121		10.0						80.00			8.00												421	1		
Sheet 108 of 121		11.0						129.50			4.00											561	1			
Sheet 109 of 121											64.25															
Sheet 110 of 121		10.0					20.00	92.00			8.00						1	1		1			448	1		
Sheet 111 of 121											39.00															
CSJ 0495-01-079 TOTALS	0.0	181.0	0.00	0.00	0.00	0.00	0	40.25	2476.75	0.00	609.00	85.00	571.00	2	0	1	1	11	0	12	8459	15	0	0	0	0

SUMMARY OF SIGNING ITEMS	104	416	416	432	540	540	544	636	636	636	636	636	636	644	644	644	644	644	644	647	647	650	650	654	658	
	6013	6018	2022	6045	6002	6016	6001	6001	6002	6003	6007	6008	6009	6001	6004	6005	6036	6051	6064	6076	6001	6003	6038	6204	6007	6061
	REMOVING CONC (FOUNDATIONS)	DRILL SHAFT (SIGN MTS) (24 IN)	DRILL SHAFT (SIGN MTS)(48 IN)	RIPRAP (MOW STRIP)(4 IN)	MTL W-BEAM GD FEN (STEEL POST)	DOWNSTREAM ANCHOR TERMINAL SECTION	GUARDRAIL END TREATMENT (INSTALL)	ALUMINUM SIGNS (TY A)	ALUMINUM SIGNS (TY G)	ALUMINUM SIGNS (TY O)	REPLACE EXISTING ALUMINUM SIGNS(TY A)	REPLACE EXISTING ALUMINUM SIGNS(TY G)	REPLACE EXISTING ALUMINUM SIGNS(TY O)	IN SM RD SN SUP&AM TY10BWG(1)S A(P)	IN SM RD SN SUP&AM TY10BWG(1)S A(T)	IN SM RD SN SUP&AM TY10BWG(1)SA(T-2EXT)	IN SM RD SN SUP&AM TY80(1)SA(U-BM)	IN SM RD SN SUP&AM TY80(2)SA(P-EXAL)	IN BRIDGE MNT CLEARANCE SGN ASSM(TY N)	REMOVE SM RD SN SUP&AM	INSTALL LRSS (STRUCT STEEL)	REMOVE LRSA	INS OH SN SUP(35 FT CANT)	REMOVE OVERHD SIGN SUP	REMOVE SIGN WALKWAY	INSTR DEL ASSM (D-SW)SZ 1(BRF)GF2
SY	LF	LF	CY	LF	EA	EA	SF	SF	SF	SF	SF	SF	EA	EA	EA	EA	EA	EA	EA	EA	EA	EA	EA	EA	EA	EA
CSJ 2374-02-157																										
Sheet 112 of 121											48.00	177.50	686.25													
Sheet 113 of 121											140.00	1095.00														
Sheet 114 of 121											12.00	75.00	77.25													
Sheet 115 of 121												375.50														
Sheet 116 of 121											4.00	75.00	102.75													
Sheet 117 of 121											67.25	84.75	482.50		1					1						
Sheet 118 of 121											70.50	37.50	117.00													
Sheet 119 of 121											29.50	258.50							2							
Sheet 120 of 121											50.00	79.50	391.00													
Sheet 121 of 121											88.00	79.50	433.75													
CSJ 02374-02-157 TOTALS	0.00	0.00	0.00	0.00	0.00	0	0.00	0.00	0.00	0.00	369.25	748.75	4019.50	0	1	0	0	0	4	1	0	0	0	0	1	0
PROJECT TOTALS	6.23	312.5	16.0	13.7	175.0	1.0	1.0	177.8	4091.0	127.25	2838.15	4575.50	30814.75	2	5	1	5	26	30	35	14664	28	1.0	1	1	6

® Texas Department of Transportation
 ©2023

PROJECT SUMMARY

SHEET 3 OF 3

DESIGN/CK CHECK BLS	FED. RD. DIV. NO. 6	STATE PROJECT NO. (SEE TITLE SHEET)		HIGHWAY NO. IH 20
CHECK MA	STATE TEXAS	DISTRICT DAL	COUNTY VARIOUS	7
CHECK BA	CONTROL 0095	SECTION 14	JOB 033, ETC	

SUMMARY OF LARGE SIGNS

PLAN SHEET NO.	SIGN NO.	SIGN BACK-GROUND COLOR	SIGN TEXT	SIGN DIMENSIONS	STATE SUPPLIED SF	OVERHEAD (TYPE O) SF	GROUND MOUNT (TYPE G) SF	PLAQUES, & OTHER ATTACHMENTS		REPLACE			TYPE OF MOUNT	GALVANIZED STRUCTURAL STEEL				DRILLED SHAFT					
								DIRECT APPLY	* ALUMINUM (TYPE A)	ALUM TY A (TYPE A)	GROUND MOUNT (TYPE G)	OVERHEAD (TYPE O)		SIZE	post 1	post 2	post 3	TOTAL WEIGHT	NON-REINF	REINFORCED			
			IH 20 (CSJ: 2374-04-087)																				
1	2	GREEN YELLOW		8'0" x 2'6" 13'6" x 11'6" 13'6" x 3'0"				40.50															
1	6	WHITE		12'0" x 5'0"																			
1	7	GREEN		10'0" x 2'6" 36" x 36" 21'0" x 10'0"			9.00																
1	8	WHITE GREEN YELLOW		36" x 36" 36" x 36" 10'0" x 2'6" 21'6" x 2'0" 36" x 36" 21'6" x 12'6" 12'0" x 3'0"				9.00	9.00														
2	1	WHITE		12'0" x 5'0"																			
2	2	GREEN		32" x 24" 32" x 24" 26'6" x 9'6"				5.33															
2	6	GREEN		37" x 24" 25'0" x 8'6"				6.17															
3	1	WHITE GREEN YELLOW		36" x 36" 36" x 36" 10'0" x 2'6" 21'6" x 2'0" 36" x 36" 21'6" x 12'6" 12'0" x 3'0"				9.00	9.00														
PAGE TOTALS										36.00	1668.00												

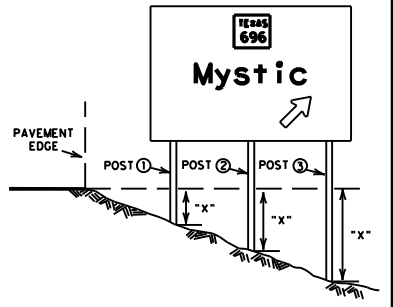

⊖ The "x" dimension is the elevation difference at the post between the ground and the edge of pavement or top of curb. Sign supports shall be located as shown on the plans, except that the Engineer may shift the sign supports, within design guidelines, where necessary to secure a more desirable location or to avoid conflict with utilities. Unless otherwise shown on the plans, the Contractor shall stake and the Engineer will verify all sign support locations.

The post lengths listed here are approximations. The corrected post lengths will be furnished by the Contractor after the stud posts are placed.

Tower heights shall be verified with the Engineer before fabrication.

* This column is for aluminum Type A and not direct apply. Direct apply is subsidiary to the sign.

SIGN TYPE

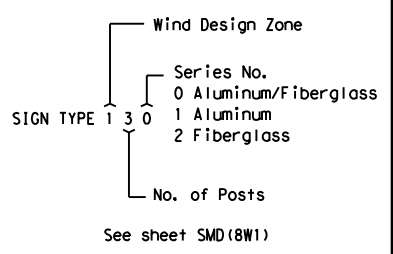

SUMMARY OF LARGE SIGNS

SHEET 1 of 35 SOLS

© TxDOT May 1987	REVISIONS
DN: TxDOT	11-93 1-04
CR: TxDOT	8-95 9-08
DN: TxDOT	5-01
CR: TxDOT	

CONT	SECT	JOB	HIGHWAY
0095	14	033, ETC	IH 20
DIST	COUNTY	SHEET NO.	
DALLAS	DALLAS	8	

DISCLAIMER: The use of this standard is governed by the "Texas Engineering Practice Act". No warranty of any kind is made by TxDOT for any purpose whatsoever. TxDOT assumes no responsibility for the conversion of this standard to other formats or for incorrect results or damages resulting from its use.
 DATE: 11/17/2023 2:27:41 PM
 FILE: T:\DAL\TRAFFIC\2023_PS8E\I\H 20\Plan_Set\I\H 20_Signing\I\H 20_SOL5-1.dgn

SUMMARY OF LARGE SIGNS

PLAN SHEET NO.	SIGN NO.	SIGN BACK-GROUND COLOR	SIGN TEXT IH 20 (CSJ: 2374-04-087)	SIGN DIMENSIONS	STATE SUPPLIED SF	OVERHEAD (TYPE O) SF	GROUND MOUNT (TYPE G) SF	PLAQUES, & OTHER ATTACHMENTS		REPLACE			TYPE OF MOUNT	GALVANIZED STRUCTURAL STEEL				DRILLED SHAFT				
								DIRECT APPLY	* ALUMINUM (TYPE A)	ALUM TY A (TYPE A)	GROUND MOUNT (TYPE G)	OVERHEAD (TYPE O)		SIZE	post ①	post ②	post ③	TOTAL WEIGHT	NON-REINF	REINFORCED 24"φ 30"φ 48"φ		
4	1	GREEN	Lake Ridge Pkwy ^{TEXAS} 161 NORTH 1/4	24" x 24"				4.00														
			President George Bush Turnpike ^{PGBT} NORTH 1/2	24" x 24"					11.25													
			Great Southwest Pkwy 1 3/4	31'6" x 11'6"																		
4	2	GREEN	Belt Line Rd ^{FM} 1382 1/2	37" x 24"				6.17														
			Mt Creek Pkwy 1 1/2	33" x 24"					5.50													
			Clark Rd ^{SPUR} 408 2 1/2	22'0" x 8'6"																		
6	2	WHITE	NO TRUCKS LEFT LANE	12'0" x 5'0"																		
6	6	GREEN	Mt Creek Pkwy 3/4 Clark Rd ^{SPUR} 408 2 3/4 Cedar Ridge Dr 3 1/2	33" x 24" 21'0" x 8'0"				5.50														
6	8	GREEN	Carrier Pkwy 1 3/4																			
			Lake Ridge Pkwy ^{TEXAS} 161 NORTH 1/4	24" x 24"					4.00													
			President George Bush Turnpike ^{PGBT} NORTH 1/2	24" x 24"					4.00													
6	9	GREEN	EXIT 458 Mt Creek Pkwy 1/2 MILE	8'0" x 2'6" 18'6" x 6'0"																		
6	12	GREEN	^{HM} MUST FOLLOW 20 OR ^{SPUR} 408	24" x 24" 36" x 36" 49" x 36" 18'0" x 8'0"				4.00 9.00 12.25														
PAGE TOTALS																					1377.75	
PAGE TOTALS																						

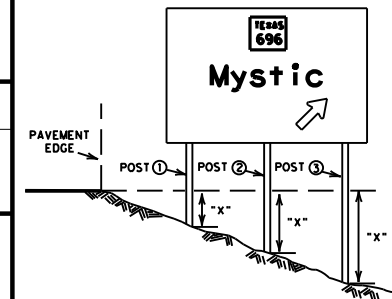

⊙ The "x" dimension is the elevation difference at the post between the ground and the edge of pavement or top of curb.

Sign supports shall be located as shown on the plans, except that the Engineer may shift the sign supports, within design guidelines, where necessary to secure a more desirable location or to avoid conflict with utilities. Unless otherwise shown on the plans, the Contractor shall stake and the Engineer will verify all sign support locations.

The post lengths listed here are approximations, The corrected post lengths will be furnished by the Contractor after the stud posts are placed.

Tower heights shall be verified with the Engineer before fabrication.

* This column is for aluminum Type A and not direct apply. Direct apply is subsidiary to the sign.

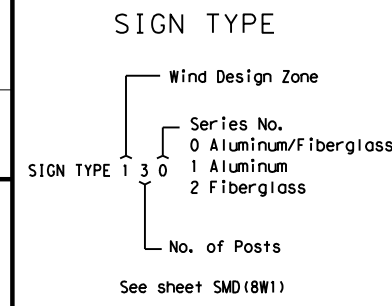

SUMMARY OF LARGE SIGNS

SHEET 2 of 35 SOLS

© TxDOT May 1987

DN. #	TxDOT	REVISIONS
0095	11-93	1-04
	8-95	9-08
	5-01	

CONT	SECT	JOB	HIGHWAY
0095	14	033, ETC	IH 20
DIST	COUNTY	SHEET NO.	
DALLAS	VARIOUS	9	





19

DATE: 2/20/2023 2:12:41 PM
 FILE: I:\DAL\TRAFFIC\2023_PS&E\IH 20\Plan_Set\IH 20_Signing\IH 20_SOLs-1.dgn
 DISCLAIMER: The use of this standard is governed by the "Texas Engineering Practice Act". No warranty of any kind is made by TxDOT for any purpose whatsoever. TxDOT assumes no responsibility for the conversion of this standard to other formats or for incorrect results or damages resulting from its use.

DISCLAIMER: The use of this standard is governed by the "Texas Engineering Practice Act". No warranty of any kind is made by TxDOT for any purpose whatsoever. TxDOT assumes no responsibility for the conversion of this standard to other formats or for incorrect results or damages resulting from its use.

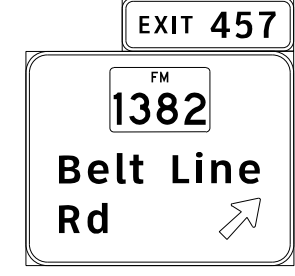
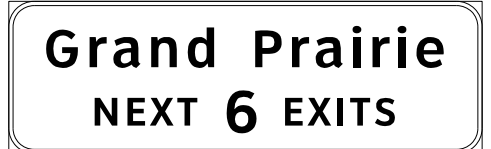
DATE: 2/21/23 PM 2:21:13
 FILE: \\DALTRAFM\FY 2023_PSBE\IH 20\Plan_Set\IH 20_Signing\IH 20_SOLS-1.dgn

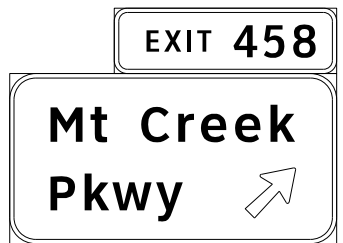
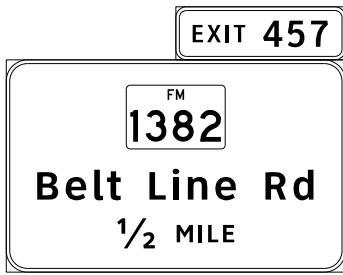
SUMMARY OF LARGE SIGNS

PLAN SHEET NO.	SIGN NO.	SIGN BACK-GROUND COLOR	SIGN TEXT IH 20 (CSJ: 2374-04-087)	SIGN DIMENSIONS	STATE SUPPLIED SF	OVERHEAD (TYPE O) SF	GROUND MOUNT (TYPE G) SF	PLAQUES, & OTHER ATTACHMENTS		REPLACE			TYPE OF MOUNT	GALVANIZED STRUCTURAL STEEL				DRILLED SHAFT						
								DIRECT APPLY	* ALUMINUM (TYPE A)	ALUM TY A (TYPE A)	GROUND MOUNT (TYPE G)	OVERHEAD (TYPE O)		SIZE	post 1	post 2	post 3	TOTAL WEIGHT	NON-REINF	REINFORCED 24"ϕ 30"ϕ 48"ϕ				
7	2	GREEN		8'0" x 2'6" 56" x 36" 12'6" x 10'6"																				
7	3	GREEN		14'0" x 5'0"							70.00													
7	4	GREEN		24'0" x 6'6"			156.00							331	W6X12	14.93	16.18	17.44	704			16.5		
7	5	WHITE		12'0" x 5'0"																				
7	6	GREEN		8'0" x 2'6" 12'6" x 6'6"																				
8	1	GREEN		8'0" x 2'6" 56" x 36" 16'0" x 10'0"			14.00																	
8	3	BROWN		20'6" x 7'6"																				
PAGE TOTALS							156.00																	

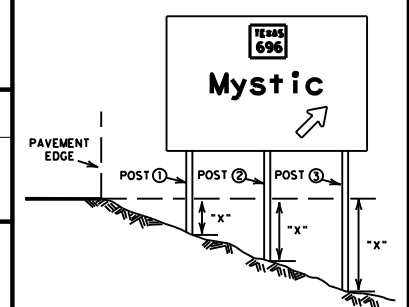

The "x" dimension is the elevation difference of the post between the ground and the edge of pavement or top of curb.
 Sign supports shall be located as shown on the plans, except that the Engineer may shift the sign supports, within design guidelines, where necessary to secure a more desirable location or to avoid conflict with utilities. Unless otherwise shown on the plans, the Contractor shall stake and the Engineer will verify all sign support locations.
 The post lengths listed here are approximations. The corrected post lengths will be furnished by the Contractor after the stud posts are placed.
 Tower heights shall be verified with the Engineer before fabrication.

* This column is for aluminum Type A and not direct apply. Direct apply is subsidiary to the sign.

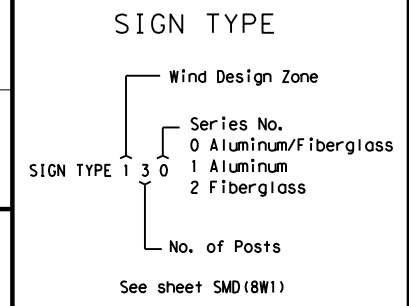

SUMMARY OF LARGE SIGNS

SOLS

SHEET 3 of 35

© TxDOT May 1987

CONT	SECT	JOB	HIGHWAY
0095	14	033, ETC	IH 20
DIST	COUNTY		SHEET NO.
DALLAS	VARIOUS		10

DISCLAIMER: The use of this standard is governed by the "Texas Engineering Practice Act". No warranty of any kind is made by TxDOT for any purpose whatsoever. TxDOT assumes no responsibility for the conversion of this standard to other formats or for incorrect results or damages resulting from its use.

DATE: 11/17/2023 2:27:51 PM
 FILE: T:\DAL\TRAFFIC\2023_PS&E\IH 20\Plan_Set\IH 20_Signing\IH 20_SOL5-1.dgn

SUMMARY OF LARGE SIGNS

PLAN SHEET NO.	SIGN NO.	SIGN BACK-GROUND COLOR	SIGN TEXT IH 20 (CSJ: 2374-04-087)	SIGN DIMENSIONS	STATE SUPPLIED SF	OVERHEAD (TYPE O) SF	GROUND MOUNT (TYPE G) SF	PLAQUES, & OTHER ATTACHMENTS		REPLACE			TYPE OF MOUNT	GALVANIZED STRUCTURAL STEEL				DRILLED SHAFT				
								DIRECT APPLY	* ALUMINUM (TYPE A)	ALUM TY A (TYPE A)	GROUND MOUNT (TYPE G)	OVERHEAD (TYPE O)		SIZE	post 1	post 2	post 3	TOTAL WEIGHT	NON-REINF	REINFORCED 24"φ 30"φ 48"φ		
9	4	GREEN YELLOW		3'0" x 3'0" 8'0" x 2'6" 49" x 36" 22'0" x 10'6" 144" x 36"						9.00												
10	3	GREEN		21'6" x 8'0"																		
11	1	GREEN		37" x 24" 22'6" x 8'0"						9.25												
11	3	GREEN YELLOW		3'0" x 3'0" 8'0" x 2'6" 49" x 36" 12'6" x 8'6" 150" x 36"						9.00												
12	1	GREEN YELLOW		3'0" x 3'0" 8'0" x 2'6" 49" x 36" 12'6" x 8'6" 150" x 36"						9.00												
12	3	GREEN		8'0" x 2'6" 19'6" x 5'6"																		
12	4	GREEN		8'0" x 2'6" 16'0" x 6'6"																		
PAGE TOTALS											27.00	1106.75										

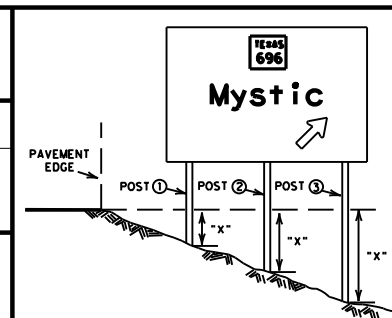

⊖ The "x" dimension is the elevation difference between the ground and the edge of pavement or top of curb.
 Sign supports shall be located as shown on the plans, except that the Engineer may shift the sign supports, within design guidelines, where necessary to secure a more desirable location or to avoid conflict with utilities. Unless otherwise shown on the plans, the Contractor shall stake and the Engineer will verify all sign support locations.
 The post lengths listed here are approximations. The corrected post lengths will be furnished by the Contractor after the stud posts are placed.
 Tower heights shall be verified with the Engineer before fabrication.

* This column is for aluminum Type A and not direct apply. Direct apply is subsidiary to the sign.

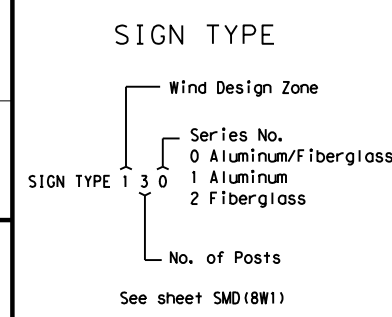

SUMMARY OF LARGE SIGNS
SOLS

SHEET 5 of 35

© TxDOT May 1987

CONTRACT	0095	SECTION	14	JOB	033, ETC	HIGHWAY	IH 20
DISTRICT	DALLAS	COUNTY	VARIOUS	SHEET NO.	12		

REVISIONS

DATE	BY	REVISIONS
11-93	TxDOT	1-04
8-95	TxDOT	9-08
5-01	TxDOT	

SUMMARY OF LARGE SIGNS

PLAN SHEET NO.	SIGN NO.	SIGN BACK-GROUND COLOR	SIGN TEXT IH 20 (CSJ: 2374-04-087)	SIGN DIMENSIONS	STATE SUPPLIED SF	OVERHEAD (TYPE O) SF	GROUND MOUNT (TYPE G) SF	PLAQUES, & OTHER ATTACHMENTS		REPLACE			TYPE OF MOUNT	GALVANIZED STRUCTURAL STEEL				DRILLED SHAFT			
								DIRECT APPLY	* ALUMINUM (TYPE A)	ALUM TY A (TYPE A)	GROUND MOUNT (TYPE G)	OVERHEAD (TYPE O)		SIZE	post ①	post ②	post ③	TOTAL WEIGHT	NON-REINF	REINFORCED 24"φ	30"φ
13	1	WHITE	NO TRUCKS LEFT LANE	12'0" X 5'0"								60.00		INSTALL ON EXISTING	T-MOUNT						
13	5	GREEN	SPUR 408 Mt Creek Pkwy 1 Belt Line Rd 1382 2 1/4 3 1/4	33" X 24" 24'0" X 8'6" 37" X 24"				5.50				204.00		INSTALL ON EXISTING	T-MOUNT						
13	7	GREEN	EXIT 461 Cedar Ridge Dr	8'0" X 2'6" 16'0" X 6'6"								20.00 104.00		INSTALL ON EXISTING	COSS						
13	8	GREEN	Duncanville Rd 1 North Main St Cockrell Hill Rd 2 Camp Wisdom Rd	22'0" X 10'6"								231.00		INSTALL ON EXISTING	T-MOUNT						
13	10	WHITE	NO TRUCKS LEFT LANE	12'0" X 5'0"								60.00		INSTALL ON EXISTING	T-MOUNT						
14	2	GREEN	EXIT 461 Cedar Ridge Dr 1/4 MILE	8'0" X 2'6" 19'6" X 5'6"				20.00 107.25						INSTALL ON PROP COSS #1						16	
14	5	GREEN	EXIT 462 Duncanville Rd North Main St 1/4 MILE	8'0" X 2'6" 18'6" X 8'0"								20.00 148.00		INSTALL ON EXISTING	COSS						
14	7	GREEN	EXIT 462 Duncanville Rd North Main St	8'0" X 2'6" 22'0" X 6'6"								20.00 143.00		INSTALL ON EXISTING	COSS						
PAGE TOTALS								127.25				1010.00		PAGE TOTALS							

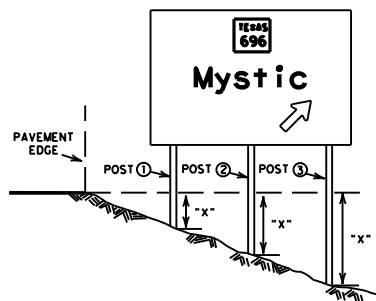

The "x" dimension is the elevation difference at the post between the ground and the edge of pavement or top of curb.
 Sign supports shall be located as shown on the plans, except that the Engineer may shift the sign supports, within design guidelines, where necessary to secure a more desirable location or to avoid conflict with utilities. Unless otherwise shown on the plans, the Contractor shall stake and the Engineer will verify all sign support locations.
 The post lengths listed here are approximations. The corrected post lengths will be furnished by the Contractor after the stud posts are placed.
 Tower heights shall be verified with the Engineer before fabrication.

* This column is for aluminum Type A and not direct apply. Direct apply is subsidiary to the sign.

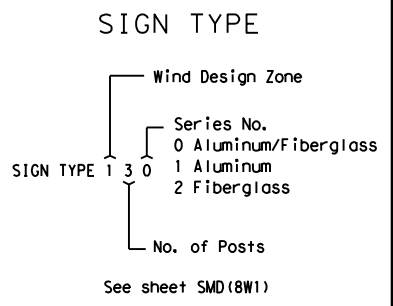

SUMMARY OF LARGE SIGNS

SOLS

SHEET 6 of 35



© TxDOT May 1987

REV.	DATE	BY	REVISIONS
0095	11-93	TxDOT	1-04
	8-95	TxDOT	9-08
	5-01	TxDOT	

CONT	SECT	JOB	HIGHWAY
0095	14	033, ETC	IH 20
DIST	COUNTY		SHEET NO.
DALLAS	VARIOUS		13

DISCLAIMER: The use of this standard is governed by the "Texas Engineering Practice Act". No warranty of any kind is made by TxDOT for any purpose whatsoever. TxDOT assumes no responsibility for the conversion of this standard to other formats or for incorrect results or damages resulting from its use.
 DATE: 11/17/2023 2:27:54 PM
 FILE: T:\DAL\TRAFFIC\2023 PS&E\IH 20\Plan_Set\IH 20\Signing\IH 20_SOLS-1.dgn

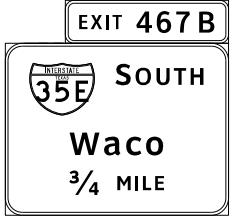
SUMMARY OF LARGE SIGNS

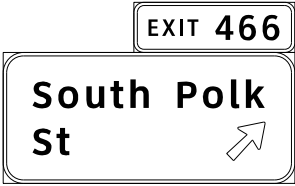
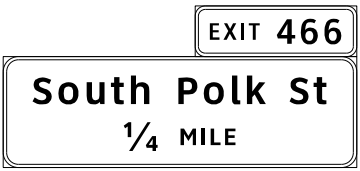
PLAN SHEET NO.	SIGN NO.	SIGN BACK-GROUND COLOR	SIGN TEXT	SIGN DIMENSIONS	STATE SUPPLIED SF	OVERHEAD (TYPE O) SF	GROUND MOUNT (TYPE G) SF	PLAQUES, & OTHER ATTACHMENTS		REPLACE			TYPE OF MOUNT	GALVANIZED STRUCTURAL STEEL				DRILLED SHAFT			
								DIRECT APPLY	* ALUMINUM (TYPE A)	ALUM TY A (TYPE A)	GROUND MOUNT (TYPE G)	OVERHEAD (TYPE O)		SIZE	post 1	post 2	post 3	TOTAL WEIGHT	NON-REINF	REINFORCED	
			IH 20 (CSJ: 2374-04-087)																		
23	8	WHITE		9'0" x 9'0"							81.00										
23	7	GREEN		10'0" x 2'6" 45" x 36" 13'6" x 10'0"				11.25													
23	8	GREEN		10'0" x 2'6" 45" x 36" 13'6" x 10'0"				11.25													
24	1	GREEN		8'0" x 2'6" 14'6" x 6'6"																	
24	2	GREEN		8'0" x 2'6" 17'6" x 5'6"																	
				PAGE TOTALS							81.00	550.5	PAGE TOTALS								

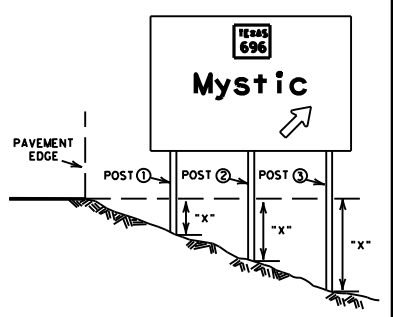

⊖ The "x" dimension is the elevation difference at the post between the ground and the edge of pavement or top of curb.

Sign supports shall be located as shown on the plans, except that the Engineer may shift the sign supports, within design guidelines, where necessary to secure a more desirable location or to avoid conflict with utilities. Unless otherwise shown on the plans, the Contractor shall stake and the Engineer will verify all sign support locations.

The post lengths listed here are approximations. The corrected post lengths will be furnished by the Contractor after the stud posts are placed.

Tower heights shall be verified with the Engineer before fabrication.

* This column is for aluminum Type A and not direct apply. Direct apply is subsidiary to the sign.

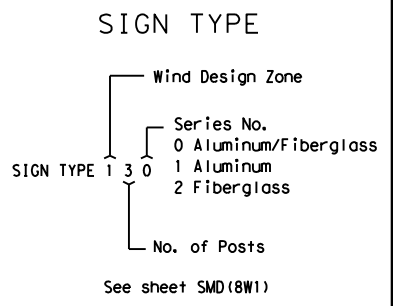

SUMMARY OF LARGE SIGNS

SHEET 10 of 35 SOLS

© TxDOT May 1987

DN. - TxDOT	REVISIONS
CR. - TxDOT	11-93 1-04
DN. - TxDOT	8-95 9-08
CR. - TxDOT	5-01





CONT	SECT	JOB	HIGHWAY
0095	14	033, ETC	IH 20
DIST	COUNTY		SHEET NO.
DALLAS	VARIOUS		17

DATE: 1/17/2023 2:28:03 PM
 FILE: T:\DAL\TRAFFIC\2023 PS&E\IH 20\Plan Set\IH 20 Signing\IH 20 SOLS-1.dgn
 DISCLAIMER: The use of this standard is governed by the "Texas Engineering Practice Act". No warranty of any kind is made by TxDOT for any purpose whatsoever. TxDOT assumes no responsibility for the conversion of this standard to other formats or for incorrect results or damages resulting from its use.

DISCLAIMER: The use of this standard is governed by the "Texas Engineering Practice Act". No warranty of any kind is made by TxDOT for any purpose whatsoever. TxDOT assumes no responsibility for the conversion of this standard to other formats or for incorrect results or damages resulting from its use.

DATE: 1/17/2023 2:28:08 PM
 FILE: T:\DAL\TRAFFIC\2023_PSR\IH 20\Plan_Set\IH 20_Signing\IH 20_SOLS-1.dgn

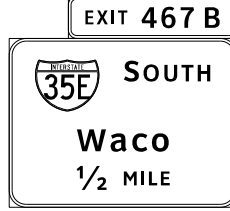
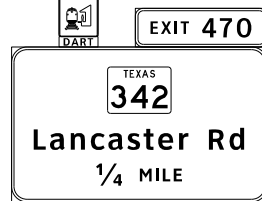
SUMMARY OF LARGE SIGNS

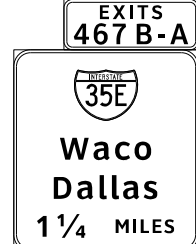
PLAN SHEET NO.	SIGN NO.	SIGN BACK-GROUND COLOR	SIGN TEXT IH 20 (CSJ: 2374-03-092)	SIGN DIMENSIONS	STATE SUPPLIED SF	OVERHEAD (TYPE O) SF	GROUND MOUNT (TYPE G) SF	PLAQUES, & OTHER ATTACHMENTS		REPLACE			TYPE OF MOUNT	GALVANIZED STRUCTURAL STEEL				DRILLED SHAFT								
								DIRECT APPLY	* ALUMINUM (TYPE A)	ALUM TY A (TYPE A)	GROUND MOUNT (TYPE G)	OVERHEAD (TYPE O)		SIZE	post ①	post ②	post ③	TOTAL WEIGHT	NON-REINF	REINFORCED 24"φ 30"φ 48"φ						
26	2	GREEN		10' 0" x 2' 6" 45" x 36" 13' 6" x 8' 6"					11.25			25.00 114.75														
27	1	GREEN		10' 0" x 2' 6" 45" x 36" 13' 6" x 9' 6"					11.25			25.00 128.25														
27	2	GREEN		10' 0" x 2' 6" 45" x 36" 13' 6" x 9' 6"					11.25			25.00 128.25														
27	11	GREEN		2' 6" x 2' 6" 2' 6" x 0' 8" 8' 0" x 2' 6" 49" x 36" 16' 6" x 10' 0"					12.25	6.25 1.67		20.00 165.00														
27	12	GREEN		19' 6" x 5' 6"								107.25														
27	13	GREEN		2' 6" x 2' 6" 2' 6" x 0' 8" 49" x 36" 8' 0" x 2' 6" 13' 0" x 10' 0"					12.25	6.25 1.67		20.00 130.00														
28	1	GREEN		8' 0" x 3' 0" 45" x 36" 11' 0" x 12' 0"					11.25			24.00 132.00														
PAGE TOTALS											15.84	1044.50														

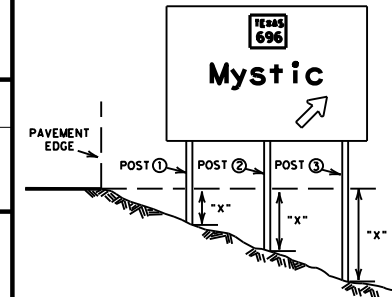

⊙ The "x" dimension is the elevation difference at the post between the ground and the edge of pavement or top of curb.

Sign supports shall be located as shown on the plans, except that the Engineer may shift the sign supports, within design guidelines, where necessary to secure a more desirable location or to avoid conflict with utilities. Unless otherwise shown on the plans, the Contractor shall stake and the Engineer will verify all sign support locations.

The post lengths listed here are approximations. The corrected post lengths will be furnished by the Contractor after the stud posts are placed.

Tower heights shall be verified with the Engineer before fabrication.

* This column is for aluminum Type A and not direct apply. Direct apply is subsidiary to the sign.

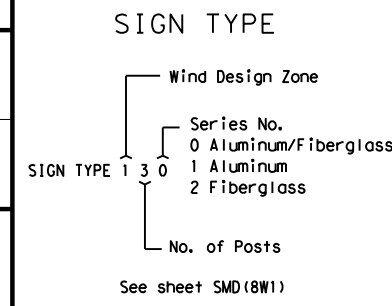

SUMMARY OF LARGE SIGNS			
SHEET 12 of 35		SOLS	
© TxDOT May 1987			
DN: TxDOT	REVISIONS		
CR: TxDOT	11-93	1-04	
DR: TxDOT	8-95	9-08	
CR: TxDOT	5-01		
CONT	SECT	JOB	HIGHWAY
0095	14	033, ETC	IH 20
DIST	COUNTY		SHEET NO.
DALLAS	VARIOUS		19

DISCLAIMER: The use of this standard is governed by the "Texas Engineering Practice Act". No warranty of any kind is made by TxDOT for any purpose whatsoever. TxDOT assumes no responsibility for the conversion of this standard to other formats or for incorrect results or damages resulting from its use.

DATE: 1/17/2023 2:28:11 PM
 FILE: I:\DAL\TRAFM\FY 2023_PS8E\IH 20\Plan_Set\IH 20_Signing\IH 20_SOLs-1.dgn

SUMMARY OF LARGE SIGNS

PLAN SHEET NO.	SIGN NO.	SIGN BACK-GROUND COLOR	SIGN TEXT IH 20 (CSJ: 2374-03-092)	SIGN DIMENSIONS	STATE SUPPLIED SF	OVERHEAD (TYPE O) SF	GROUND MOUNT (TYPE G) SF	PLAQUES, & OTHER ATTACHMENTS		REPLACE			TYPE OF MOUNT	GALVANIZED STRUCTURAL STEEL				DRILLED SHAFT																																
								DIRECT APPLY	* ALUMINUM (TYPE A)	ALUM TY A (TYPE A)	GROUND MOUNT (TYPE G)	OVERHEAD (TYPE O)		SIZE	post 1	post 2	post 3	TOTAL WEIGHT	NON-REINF	REINFORCED 24"φ	30"φ	48"φ																												
29	1	GREEN	1 1/2 South Polk St 2 1/2	45" x 36" 21'6" x 7'6"				11.25																																										
30	4	GREEN	Dept of Public Safety EXIT 468 Driver License Center	13'6" x 7'0" 13'6" x 1'6"						94.50 20.25																																								
30	6	GREEN	EXIT 470 Lancaster Rd	2'6" x 2'6" 2'6" x 0'8" 8'0" x 2'6" 49" x 36" 13'0" x 10'0"				12.25		6.25 1.67	20.00																																							
30	7	GREEN	Bonnie View Rd 1 1/4 JJ Lemmon Rd 2 1/4 2 1/2	36" x 36" 23'0" x 9'0"				9.00			207.00																																							
31	3	WHITE	NO TRUCKS LEFT LANE	12'0" x 5'0"							60.00																																							
31	4	GREEN	EXIT 470 Lancaster Rd 3/4 MILE	2'6" x 2'6" 2'6" x 0'8" 8'0" x 2'6" 49" x 36" 16'6" x 10'0"				12.25		6.25 1.67	20.00																																							
31	5	GREEN	EXIT 472 Bonnie View Rd 3/4 MILE	8'0" x 2'6" 19'6" x 6'0"							20.00 117.00																																							
PAGE TOTALS																																																		

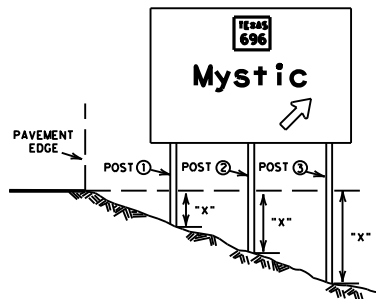

The "x" dimension is the elevation difference at the post between the ground and the edge of pavement or top of curb.
 Sign supports shall be located as shown on the plans, except that the Engineer may shift the sign supports, within design guidelines, where necessary to secure a more desirable location or to avoid conflict with utilities. Unless otherwise shown on the plans, the Contractor shall stake and the Engineer will verify all sign support locations.
 The post lengths listed here are approximations, The corrected post lengths will be furnished by the Contractor after the stud posts are placed.
 Tower heights shall be verified with the Engineer before fabrication.

* This column is for aluminum Type A and not direct apply. Direct apply is subsidiary to the sign.

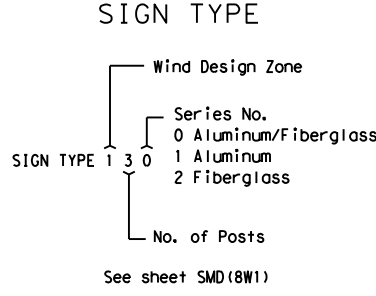

SUMMARY OF LARGE SIGNS SOLS

SHEET 13 of 35				SOLS	
<small>© TxDOT May 1987</small>					
<small>DN. - TxDOT</small>	<small>REVISIONS</small>				
<small>CK. - TxDOT</small>	11-93	1-04			
<small>CK. - TxDOT</small>	8-95	9-08			
<small>CK. - TxDOT</small>	5-01				
<small>CONT</small>	<small>SECT</small>	<small>JOB</small>	<small>HIGHWAY</small>		
0095	14	033, ETC	IH 20		
<small>DIST</small>	<small>COUNTY</small>		<small>SHEET NO.</small>		
DALLAS	VARIOUS		20		

DISCLAIMER: The use of this standard is governed by the "Texas Engineering Practice Act". No warranty of any kind is made by TxDOT for any purpose whatsoever. TxDOT assumes no responsibility for the conversion of this standard to other formats or for incorrect results or damages resulting from its use.

DATE: 2/20/2023 11:50:11 AM
 FILE: T:\DAL\TRAFFIC\2023_PS&E\IH 20\Plan_Set\IH 20\Signing\IH 20_SOLS-1.dgn

SUMMARY OF LARGE SIGNS

PLAN SHEET NO.	SIGN NO.	SIGN BACK-GROUND COLOR	SIGN TEXT	SIGN DIMENSIONS	STATE SUPPLIED SF	OVERHEAD (TYPE O) SF	GROUND MOUNT (TYPE G) SF	PLAQUES, & OTHER ATTACHMENTS		REPLACE			TYPE OF MOUNT	GALVANIZED STRUCTURAL STEEL				DRILLED SHAFT				
								DIRECT APPLY	* ALUMINUM (TYPE A)	ALUM TY A (TYPE A)	GROUND MOUNT (TYPE G)	OVERHEAD (TYPE O)		SIZE	post ①	post ②	post ③	TOTAL WEIGHT	NON-REINF	REINFORCED		
			IH 20 (CSJ:2374-03-092)																			
32	1	GREEN	<div style="border: 1px solid black; padding: 5px;"> <p>Lancaster Rd TEXAS 342 1</p> <hr/> <p>Houston School Rd 2</p> <hr/> <p>University Hills Blvd 2</p> </div>	32" x 24" 23'6" x 9'0"				5.33														
32	2	GREEN	<div style="border: 1px solid black; padding: 5px;"> <p>EXIT 473B-C</p> <p>Dallas Houston 1 3/4 MILES</p> </div>	11'6" x 2'6" 11'6" x 12'0"								28.75 138.00										
32	3	GREEN	<div style="border: 1px solid black; padding: 5px;"> <p>EXIT 472</p> <div style="border: 1px solid black; padding: 5px; width: fit-content; margin: auto;"> <p>Bonnie View Rd ↗</p> </div> </div>	8'0" x 2'6" 16'0" x 6'6"								20.00 104.00										
34	1	GREEN	<div style="border: 1px solid black; padding: 5px;"> <p>EXIT 472</p> <div style="border: 1px solid black; padding: 5px; width: fit-content; margin: auto;"> <p>Bonnie View Rd ↗</p> </div> <p>1/2 MILE</p> </div>	8'0" x 2'6" 19'6" x 5'6"								20.00 107.25										
35	3	GREEN	<div style="border: 1px solid black; padding: 5px;"> <p>Bonnie View Rd ↗ 3/4</p> <p>Lancaster Rd TEXAS 342 2 1/2</p> <hr/> <p>Houston School Rd ↗ 3 1/2</p> <p>University Hills Blvd</p> </div>	32" x 24" 25'0" x 11'0"				5.33														
35	5	GREEN	<div style="border: 1px solid black; padding: 5px;"> <p>EXIT 473C</p> <p>SOUTH</p> <hr/> <p>Houston ↗</p> </div>	10'0" x 2'6" 36" x 36" 15'0" x 8'6"				9.00				25.00 127.50										
35	6	GREEN	<div style="border: 1px solid black; padding: 5px;"> <p>EXIT 473B</p> <p>NORTH</p> <hr/> <p>Dallas ↗</p> <p>1/4 MILE</p> </div>	10'0" x 2'6" 36" x 36" 12'6" x 10'0"				9.00				25.00 125.00										
PAGE TOTALS																						1207.00

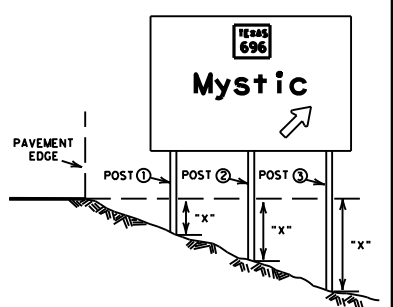

The "x" dimension is the elevation difference at the post between the ground and the edge of pavement or top of curb.
 Sign supports shall be located as shown on the plans, except that the Engineer may shift the sign supports, within design guidelines, where necessary to secure a more desirable location or to avoid conflict with utilities. Unless otherwise shown on the plans, the Contractor shall stake and the Engineer will verify all sign support locations.
 The post lengths listed here are approximations. The corrected post lengths will be furnished by the Contractor after the stud posts are placed.
 Tower heights shall be verified with the Engineer before fabrication.

* This column is for aluminum Type A and not direct apply. Direct apply is subsidiary to the sign.

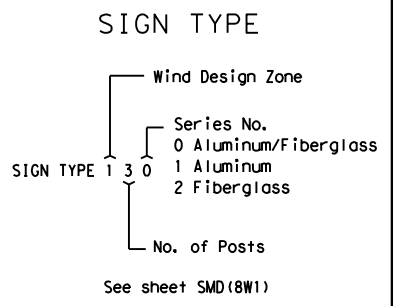

SUMMARY OF LARGE SIGNS

SOLS

SHEET 14 of 35

© TxDOT May 1987

REV.	BY	DATE	REVISIONS
11-93		1-04	
8-95		9-08	
5-01			



CONT	SECT	JOB	HIGHWAY
0095	14	033, ETC	IH 20
DALLAS			VARIOUS
			SHEET NO. 21

19

DISCLAIMER: The use of this standard is governed by the "Texas Engineering Practice Act". No warranty of any kind is made by TxDOT for any purpose whatsoever. TxDOT assumes no responsibility for the conversion of this standard to other formats or for incorrect results or damages resulting from its use.

DATE: 1/17/2023 2:28:21 PM
 FILE: T:\DAL\TRAFFIC\2023_PS8E\IH 20\Plan_Set\IH 20_Signing\IH 20_SOLS-1.dgn

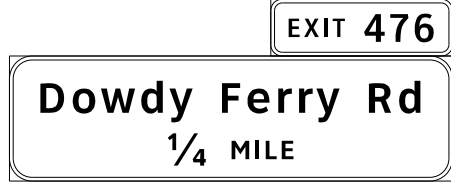
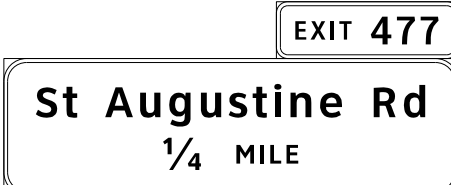
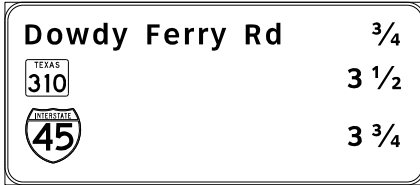
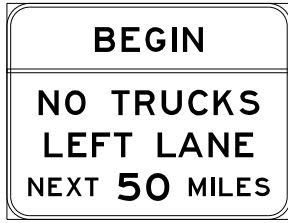
SUMMARY OF LARGE SIGNS

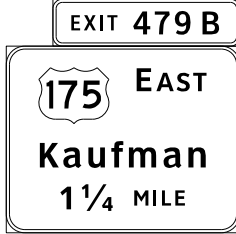
PLAN SHEET NO.	SIGN NO.	SIGN BACK-GROUND COLOR	SIGN TEXT IH 20 (CSJ: 2374-03-092)	SIGN DIMENSIONS	STATE SUPPLIED SF	OVERHEAD (TYPE O) SF	GROUND MOUNT (TYPE G) SF	PLAQUES, & OTHER ATTACHMENTS		REPLACE			TYPE OF MOUNT	GALVANIZED STRUCTURAL STEEL				DRILLED SHAFT						
								DIRECT APPLY	* ALUMINUM (TYPE A)	ALUM TY A (TYPE A)	GROUND MOUNT (TYPE G)	OVERHEAD (TYPE O)		SIZE	post ①	post ②	post ③	TOTAL WEIGHT	NON-REINF	REINFORCED 24"φ 30"φ 48"φ				
42	3	GREEN		8'0" x 2'6" 16'0" x 6'6"																				
43	1	GREEN		8'0" x 2'6" 19'6" x 5'6"																				
43	2	GREEN		8'0" x 2'6" 20'0" x 6'0"																				
44	1	GREEN		28" x 24" 36 x 36" 23'0" x 10'0"				4.67 9.00																
44	5	WHITE		12'6" x 9'6"																				
44	6	GREEN		8'0" x 2'6" 16'6" x 6'6"																				
45	1	GREEN		10'0" x 2'6" 45" x 36" 12'6" x 10'0"				11.25																

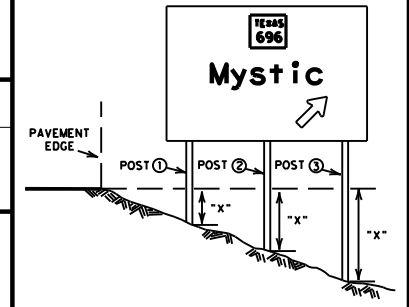

⊖ The "x" dimension is the elevation difference at the post between the ground and the edge of pavement or top of curb.

Sign supports shall be located as shown on the plans, except that the Engineer may shift the sign supports, within design guidelines, where necessary to secure a more desirable location or to avoid conflict with utilities. Unless otherwise shown on the plans, the Contractor shall stake and the Engineer will verify all sign support locations.

The post lengths listed here are approximations, The corrected post lengths will be furnished by the Contractor after the stud posts are placed.

Tower heights shall be verified with the Engineer before fabrication.

* This column is for aluminum Type A and not direct apply. Direct apply is subsidiary to the sign.

SIGN TYPE

- 130 Wind Design Zone
- Series No.
 - 0 Aluminum/Fiberglass
 - 1 Aluminum
 - 2 Fiberglass
- No. of Posts

See sheet SMD(8W1)

SUMMARY OF LARGE SIGNS

SOLS

SHEET 17 of 35

© TxDOT May 1987

REV.	DATE	BY	REVISIONS
0095	11-93		1-04
	8-95		9-08
	5-01		

CONT	SECT	JOB	HIGHWAY
0095	14	033, ETC	IH 20
DIST	COUNTY		SHEET NO.
DALLAS	VARIOUS		24

19

PAGE TOTALS

1017.25

PAGE TOTALS

DISCLAIMER: The use of this standard is governed by the "Texas Engineering Practice Act". No warranty of any kind is made by TxDOT for any purpose whatsoever. TxDOT assumes no responsibility for the conversion of this standard to other formats or for incorrect results or damages resulting from its use.
 DATE: 11/17/2023 2:28:23 PM
 FILE: T:\DAL\TRAFFIC\2023_PS&E\IH 20\Plan_Set\IH 20_Signing\IH 20_SOLs-1.dgn

SUMMARY OF LARGE SIGNS

PLAN SHEET NO.	SIGN NO.	SIGN BACK-GROUND COLOR	SIGN TEXT IH 20 (CSJ: 2374-03-092)	SIGN DIMENSIONS	STATE SUPPLIED SF	OVERHEAD (TYPE O) SF	GROUND MOUNT (TYPE G) SF	PLAQUES, & OTHER ATTACHMENTS		REPLACE			TYPE OF MOUNT	GALVANIZED STRUCTURAL STEEL				DRILLED SHAFT									
								DIRECT APPLY	* ALUMINUM (TYPE A)	ALUM TY A (TYPE A)	GROUND MOUNT (TYPE G)	OVERHEAD (TYPE O)		SIZE	post ①	post ②	post ③	TOTAL WEIGHT	NON-REINF	REINFORCED 24"φ 30"φ 48"φ							
45	2	GREEN	<div style="border: 1px solid black; padding: 5px;"> EXIT 479 A <div style="border: 1px solid black; padding: 2px; display: inline-block;">175 WEST</div> Dallas 1 MILE </div>	10'0" x 2'6" 45" x 36" 12'6" x 10'0"					11.25			25.00															
45	3	GREEN	<div style="border: 1px solid black; padding: 5px;"> EXIT 478 Haymarket Rd 1/2 MILE </div>	8'0" x 2'6" 14'0" x 8'6"								20.00 119.00															
45	4	GREEN	<div style="border: 1px solid black; padding: 5px;"> EXIT 478 Haymarket Rd </div>	8'0" x 2'6" 14'0" x 7'0"								20.00 98.00															
46	1	GREEN	<div style="border: 1px solid black; padding: 5px;"> EXIT 477 St Augustine Rd 3/4 MILE </div>	8'0" x 2'6" 20'0" x 5'6"								20.00 110.00															
46	4	WHITE	<div style="border: 1px solid black; padding: 5px; text-align: center;"> AHEAD NO TRUCKS LEFT LANE </div>	12'0" x 7'0"								84.00															
46	7	WHITE	<div style="border: 1px solid black; padding: 5px; text-align: center;"> END NO TRUCKS LEFT LANE </div>	12'0" x 7'0"								84.00															
46	8	GREEN	<div style="border: 1px solid black; padding: 5px;"> 20 EAST Shreveport </div>	3'0" x 3'0" 36" x 36" 17'6" x 10'6"					9.00		9.00																
PAGE TOTALS												9.00															
PAGE TOTALS																											

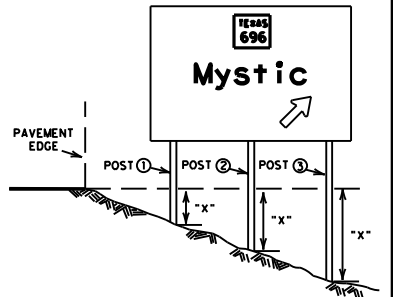

The "x" dimension is the elevation difference at the post between the ground and the edge of pavement or top of curb.
 Sign supports shall be located as shown on the plans, except that the Engineer may shift the sign supports, within design guidelines, where necessary to secure a more desirable location or to avoid conflict with utilities. Unless otherwise shown on the plans, the Contractor shall stake and the Engineer will verify all sign support locations.
 The post lengths listed here are approximations, The corrected post lengths will be furnished by the Contractor after the stud posts are placed.
 Tower heights shall be verified with the Engineer before fabrication.

* This column is for aluminum Type A and not direct apply. Direct apply is subsidiary to the sign.

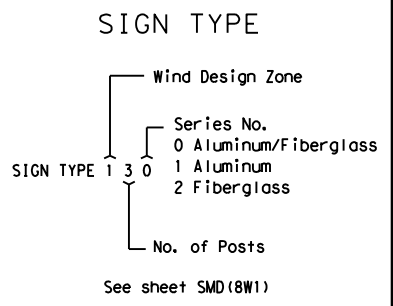

SUMMARY OF LARGE SIGNS

SOLS

SHEET 18 of 35

© TxDOT May 1987			
DN: TxDOT	REVISIONS		
CR: TxDOT	11-93 1-04		
DN: TxDOT	8-95 9-08		
CR: TxDOT	5-01		
CONT	SECT	JOB	HIGHWAY
0095	14	033, ETC	IH 20
DIST	COUNTY		SHEET NO.
DALLAS	VARIOUS		25

SUMMARY OF LARGE SIGNS

PLAN SHEET NO.	SIGN NO.	SIGN BACK-GROUND COLOR	SIGN TEXT IH 20 (CSJ: 2374-03-092)	SIGN DIMENSIONS	STATE SUPPLIED SF	OVERHEAD (TYPE O) SF	GROUND MOUNT (TYPE G) SF	PLAQUES, & OTHER ATTACHMENTS		REPLACE			TYPE OF MOUNT	GALVANIZED STRUCTURAL STEEL				DRILLED SHAFT					
								DIRECT APPLY	* ALUMINUM (TYPE A)	ALUM TY A (TYPE A)	GROUND MOUNT (TYPE G)	OVERHEAD (TYPE O)		SIZE	post ①	post ②	post ③	TOTAL WEIGHT	NON-REINF	REINFORCED 24"φ 30"φ 48"φ			
46	9	GREEN		10'0" x 2'6" 45" x 36" 12'0" x 10'0"				11.25				25.00											
46	10	GREEN		10'0" x 2'6" 45" x 36" 13'6" x 8'0"				11.25				25.00											
47	1	GREEN		28" x 24" 21'6" x 8'0"				4.67				172.00											
47	5	GREEN		10'0" x 2'6" 45" x 36" 13'6" x 8'0"				11.25				25.00											
47	7	GREEN		36" x 36" 17'6" x 10'6"				4.00				183.75											
47	8	GREEN		3'0" x 3'0" 8'0" x 2'6" 45" x 36" 29'6" x 13'0"				11.25	9.00			20.00											
47	9	GREEN		10'0" x 2'6" 45" x 36" 15'6" x 8'6"				11.25				25.00											
				PAGE TOTALS						9.00		1327.00											

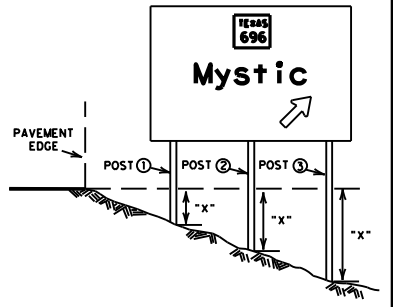

⊖ The "x" dimension is the elevation difference between the ground and the top of post or top of curb.

Sign supports shall be located as shown on the plans, except that the Engineer may shift the sign supports, within design guidelines, where necessary to secure a more desirable location or to avoid conflict with utilities. Unless otherwise shown on the plans, the Contractor shall stake and the Engineer will verify all sign support locations.

The post lengths listed here are approximations. The corrected post lengths will be furnished by the Contractor after the stud posts are placed.

Tower heights shall be verified with the Engineer before fabrication.

* This column is for aluminum Type A and not direct apply. Direct apply is subsidiary to the sign.

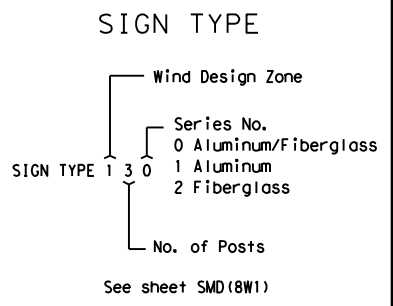

SUMMARY OF LARGE SIGNS

SHEET 19 of 35 SOLS

© TxDOT May 1987





DN: TxDOT	REVISIONS
CR: TxDOT	11-93 1-04
CR: TxDOT	8-95 9-08
CR: TxDOT	5-01

CONT	SECT	JOB	HIGHWAY
0095	14	033, ETC	IH 20
DIST	COUNTY		SHEET NO.
DALLAS	VARIOUS		26

19

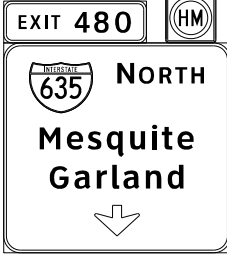
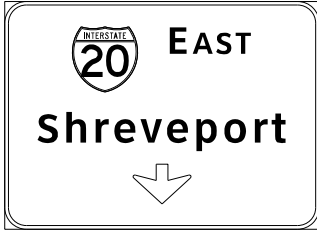
DATE: 1/17/2023 2:28:26 PM
 FILE: T:\DALTRAFM\FY 2023_PS8E\IH 20\Plan_Set\IH 20_Signing\IH 20_SOL5-1.dgn
 DISCLAIMER: The use of this standard is governed by the "Texas Engineering Practice Act". No warranty of any kind is made by TxDOT for any purpose whatsoever. TxDOT assumes no responsibility for the conversion of this standard to other formats or for incorrect results or damages resulting from its use.

SUMMARY OF LARGE SIGNS

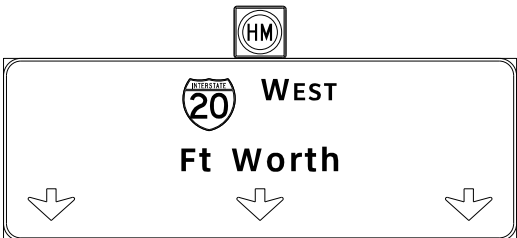
PLAN SHEET NO.	SIGN NO.	SIGN BACK-GROUND COLOR	SIGN TEXT	SIGN DIMENSIONS	STATE SUPPLIED SF	OVERHEAD (TYPE O) SF	GROUND MOUNT (TYPE G) SF	PLAQUES, & OTHER ATTACHMENTS		REPLACE			TYPE OF MOUNT	GALVANIZED STRUCTURAL STEEL				DRILLED SHAFT						
								DIRECT APPLY	* ALUMINUM (TYPE A)	ALUM TY A (TYPE A)	GROUND MOUNT (TYPE G)	OVERHEAD (TYPE O)		SIZE	post 1	post 2	post 3	TOTAL WEIGHT	NON-REINF	REINFORCED				
			IH 20 (CSJ: 2374-03-092)																					
48	10	GREEN		8'0" x 2'6" 3'0" x 3'0" 45" x 36" 13'6" x 12'6"					11.25	9.00					20.00									
48	11	GREEN		36" x 36" 14'6" x 10'6"					9.00															
END IH 20 (CSJ: 2374-03-092)				PAGE TOTALS							9.00					341.00								
BEGIN IH 20 (CSJ: 0095-13-044)				CSJ TOTALS							85.68	114.75	10549.00											
48	12	GREEN		19'0" x 7'0"												133.00								
48	13	GREEN		14'6" x 5'0"							72.50													
49	2	WHITE		45" x 36" 13'6" x 8'6"					11.25															
49	4	WHITE		12'0" x 7'0"												84.00								
49	5	GREEN		3'0" x 3'0" 36" x 36" 29'6" x 10'6"					9.00	9.00						309.75								
CSJ TOTALS										9.00	187.75	526.75												
												PAGE TOTALS												

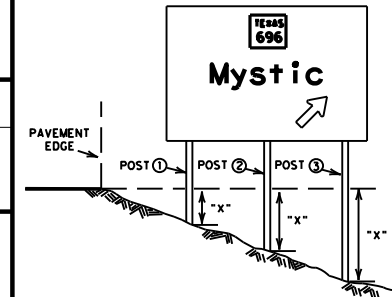

⊙ The "x" dimension is the elevation difference at the post between the ground and the edge of pavement or top of curb.

Sign supports shall be located as shown on the plans, except that the Engineer may shift the sign supports, within design guidelines, where necessary to secure a more desirable location or to avoid conflict with utilities. Unless otherwise shown on the plans, the Contractor shall stake and the Engineer will verify all sign support locations.

The post lengths listed here are approximations. The corrected post lengths will be furnished by the Contractor after the stud posts are placed.

Tower heights shall be verified with the Engineer before fabrication.

* This column is for aluminum Type A and not direct apply. Direct apply is subsidiary to the sign.

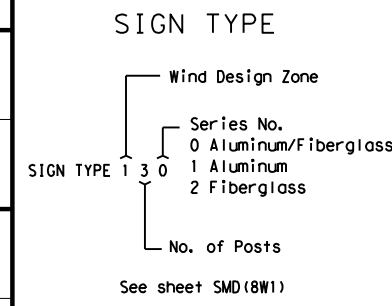

SUMMARY OF LARGE SIGNS

SHEET 21 of 35 SOLS

© TxDOT May 1987

DN.-TxDOT		REVISIONS
CK.-TxDOT	11-93	1-04
DN.-TxDOT	8-95	9-08
CK.-TxDOT	5-01	







CONT	SECT	JOB	HIGHWAY
0095	14	033, ETC	IH 20
DIST	COUNTY		SHEET NO.
DALLAS	VARIOUS		28

19

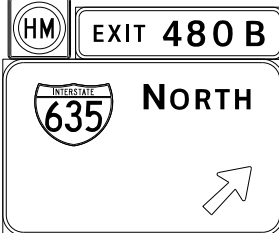
DISCLAIMER: The use of this standard is governed by the "Texas Engineering Practice Act". No warranty of any kind is made by TxDOT for any purpose whatsoever. TxDOT assumes no responsibility for the conversion of this standard to other formats or for incorrect results or damages resulting from its use.

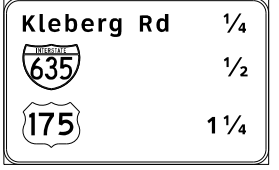
DATE: 2/20/2023 11:54:01 AM
FILE: I:\DAL\TRAFF\2023_PSBE\IH 20\Plan_Set\IH 20_Signing\IH 20 SOLS-1.dgn

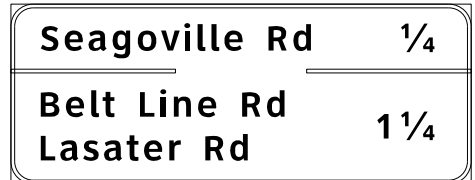
SUMMARY OF LARGE SIGNS

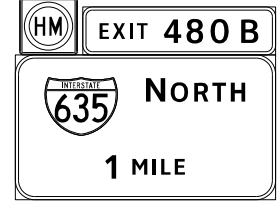
PLAN SHEET NO.	SIGN NO.	SIGN BACK-GROUND COLOR	SIGN TEXT IH 20 (CSJ:0095-13-044)	SIGN DIMENSIONS	STATE SUPPLIED SF	OVERHEAD (TYPE O) SF	GROUND MOUNT (TYPE G) SF	PLAQUES, & OTHER ATTACHMENTS		REPLACE			TYPE OF MOUNT	GALVANIZED STRUCTURAL STEEL				DRILLED SHAFT					
								DIRECT APPLY	* ALUMINUM (TYPE A)	ALUM TY A (TYPE A)	GROUND MOUNT (TYPE G)	OVERHEAD (TYPE O)		SIZE	post ①	post ②	post ③	TOTAL WEIGHT	NON-REINF	REINFORCED 24"φ 30"φ 48"φ			
49	6	GREEN		3'0" x 3'0" 45" x 36" 10'0" x 2'6" 13'6" x 8'6"				11.25	*	9.00													
50	1	GREEN		10'0" x 2'6" 11'0" x 6'6"																			
50	4	GREEN		45" x 36" 45" x 36" 17'0" x 10'6"				11.25 11.25															
50	5	WHITE		12'0" x 9'6"																			
50	6	GREEN		20'6" x 8'0"																			
50	7	GREEN		8'0" x 2'6" 13'6" x 6'6"																			
51	2	GREEN		36" x 36" 10'0" x 2'6" 45" x 36" 13'6" x 7'6"				11.25	*	9.00													
PAGE TOTALS										18.00	114.00	812.75											

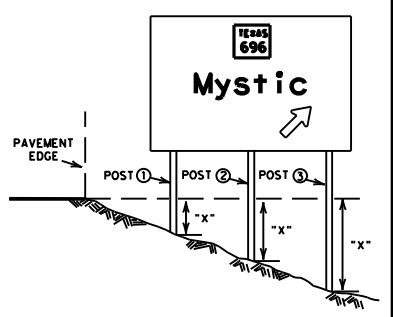

⊙ The "x" dimension is the elevation difference at the post between the ground and the edge of pavement or top of curb.

Sign supports shall be located as shown on the plans, except that the Engineer may shift the sign supports, within design guidelines, where necessary to secure a more desirable location or to avoid conflict with utilities. Unless otherwise shown on the plans, the Contractor shall stake and the Engineer will verify all sign support locations.

The post lengths listed here are approximations, The corrected post lengths will be furnished by the Contractor after the stud posts are placed.

Tower heights shall be verified with the Engineer before fabrication.

* This column is for aluminum Type A and not direct apply. Direct apply is subsidiary to the sign.

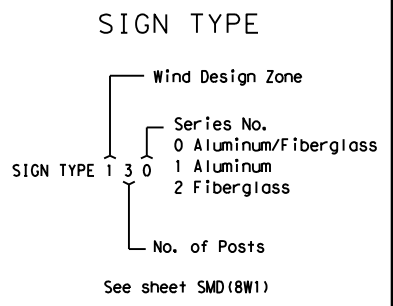

SUMMARY OF LARGE SIGNS

SOLS

SHEET 22 of 35

© TxDOT May 1987

REV.	DATE	BY	REVISIONS
0095	11-93	TxDOT	1-04
0095	8-95	TxDOT	9-08
0095	5-01	TxDOT	

CONT	SECT	JOB	HIGHWAY
0095	14	033, ETC	IH 20
DIST	COUNTY		SHEET NO.
DALLAS	VARIOUS		29

DATE: 11/17/2023 2:28:33 PM
 FILE: T:\DAL\TRAFFIC\2023_PS8E\IH 20\Plan_Set\IH 20_Signing\IH 20_SOL5-1.dgn
 DISCLAIMER: The use of this standard is governed by the "Texas Engineering Practice Act". No warranty of any kind is made by TxDOT for any purpose whatsoever. TxDOT assumes no responsibility for the conversion of this standard to other formats or for incorrect results or damages resulting from its use.

SUMMARY OF LARGE SIGNS

PLAN SHEET NO.	SIGN NO.	SIGN BACK-GROUND COLOR	SIGN TEXT IH 20 (CSJ:0095-13-044)	SIGN DIMENSIONS	STATE SUPPLIED SF	OVERHEAD (TYPE O) SF	GROUND MOUNT (TYPE G) SF	PLAQUES, & OTHER ATTACHMENTS		REPLACE			TYPE OF MOUNT	GALVANIZED STRUCTURAL STEEL			DRILLED SHAFT				
								DIRECT APPLY	* ALUMINUM (TYPE A)	ALUM TY A (TYPE A)	GROUND MOUNT (TYPE G)	OVERHEAD (TYPE O)		SIZE	post 1	post 2	post 3	TOTAL WEIGHT	NON-REINF	REINFORCED 24" ϕ 30" ϕ 48" ϕ	
51	4	GREEN	Seagoville Rd	8'0" x 2'6" 13'6" x 6'6"																	
51	5	WHITE	MUST FOLLOW 635 OR 20	18'0" x 8'0"						144.00											
51	6	GREEN	EXIT 482 Belt Line Rd Lasater Rd 1 MILE	2'6" x 2'6" 8'0" x 2'6" 16'0" x 8'0"							6.25										
52	3	GREEN	Seagoville Rd 1/4 Kleberg Rd 2/4 635 NORTH 1 1/2	45" x 36" 19'6" x 9'0"						11.25											
52	4	GREEN	Belt Line Rd 1/4 Lasater Rd Lawson Rd Lumley Rd 1 1/4	20'0" x 10'6"																	
52	5	GREEN	EXIT 482 Belt Line Rd Lasater Rd	2'6" x 2'6" 8'0" x 2'6" 18'6" x 6'6"							6.25										
53	2	GREEN	EXIT 481 Seagoville Rd 1 MILE	8'0" x 2'6" 17'6" x 5'6"																	

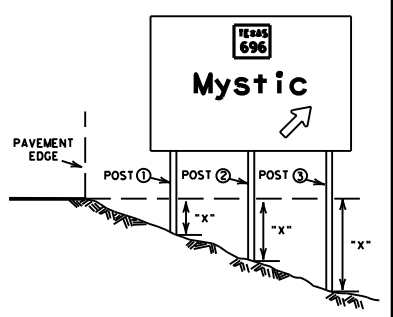

The "x" dimension is the elevation difference at the post between the ground and the edge of pavement or top of curb.

Sign supports shall be located as shown on the plans, except that the Engineer may shift the sign supports, within design guidelines, where necessary to secure a more desirable location or to avoid conflict with utilities. Unless otherwise shown on the plans, the Contractor shall stake and the Engineer will verify all sign support locations.

The post lengths listed here are approximations, The corrected post lengths will be furnished by the Contractor after the stud posts are placed.

Tower heights shall be verified with the Engineer before fabrication.

* This column is for aluminum Type A and not direct apply. Direct apply is subsidiary to the sign.

SIGN TYPE

Wind Design Zone

Series No.
 0 Aluminum/Fiberglass
 1 Aluminum
 2 Fiberglass

No. of Posts
 See sheet SMD(8W1)

SUMMARY OF LARGE SIGNS
SOLS

SHEET 23 of 35

© TxDOT May 1987

DN.-TxDOT	REVISIONS
CK.-TxDOT	11-93 1-04
DN.-TxDOT	8-95 9-08
CK.-TxDOT	5-01

CONT	SECT	JOB	HIGHWAY
0095	14	033, ETC	IH 20
DIST	COUNTY		SHEET NO.
DALLAS	VARIOUS		30

19

PAGE TOTALS 12.50 144.00 897.75

PAGE TOTALS

DISCLAIMER: The use of this standard is governed by the "Texas Engineering Practice Act". No warranty of any kind is made by TxDOT for any purpose whatsoever. TxDOT assumes no responsibility for the conversion of this standard to other formats or for incorrect results or damages resulting from its use.

DATE: 11/7/2023 2:28:36 PM
 FILE: T:\DAL\TRAFF\FY 2023_PS&E\IH 20\Plan_Sets\IH 20_Signing\IH 20_SOL5-1.dgn

DISCLAIMER: The use of this standard is governed by the "Texas Engineering Practice Act". No warranty of any kind is made by TxDOT for any purpose whatsoever. TxDOT assumes no responsibility for the conversion of this standard to other formats or for incorrect results or damages resulting from its use.

DATE: 11/17/2023 2:28:38 PM
FILE: T:\DAL\TRAFFIC\2023 PS&E\IH 20VPlan_Sets\IH 20 Signing\IH 20 SOLS-1.dgn

SUMMARY OF LARGE SIGNS

PLAN SHEET NO.	SIGN NO.	SIGN BACK-GROUND COLOR	SIGN TEXT IH 20 (CSJ:0095-13-044)	SIGN DIMENSIONS	STATE SUPPLIED SF	OVERHEAD (TYPE O) SF	GROUND MOUNT (TYPE G) SF	PLAQUES, & OTHER ATTACHMENTS		REPLACE			TYPE OF MOUNT	GALVANIZED STRUCTURAL STEEL				DRILLED SHAFT															
								DIRECT APPLY	* ALUMINUM (TYPE A)	ALUM TY A (TYPE A)	GROUND MOUNT (TYPE G)	OVERHEAD (TYPE O)		SIZE	post 1	post 2	post 3	TOTAL WEIGHT	NON-REINF	REINFORCED	24"φ	30"φ	48"φ										
53	4	GREEN	 Belt Line Rd ↗	2'6" x 2'6" 8'0" x 2'6" 12'6" x 6'6"						6.25							20.00 81.25																
53	5	GREEN	 Lawson Rd Lumley Rd 3/4 MILE	8'0" x 2'6" 14'0" x 8'0"													20.00 112.00																
54	3	GREEN	Belt Line Rd 1/4 Seagoville Rd 1 1/4 Kleberg Rd 2 1/4	21'6" x 7'0"													150.50																
54	5	WHITE	NO TRUCKS LEFT LANE	12'0" x 5'0"													60.00																
54	7	GREEN	 Lawson Rd Lumley Rd ↗	8'0" x 2'6" 18'0" x 6'6"													20.00 117.00																
55	3	WHITE	NO TRUCKS LEFT LANE	12'0" x 5'0"													60.00																
55	4	GREEN	 Belt Line Rd 1 MILE	2'6" x 2'6" 8'0" x 2'6" 16'0" x 5'6"						6.25							20.00 88.00																
55	6	GREEN	 Lawson Rd Lasater Rd ↗	8'0" x 2'6" 18'0" x 6'6"													20.00 117.00																
				PAGE TOTALS							12.50						885.75																

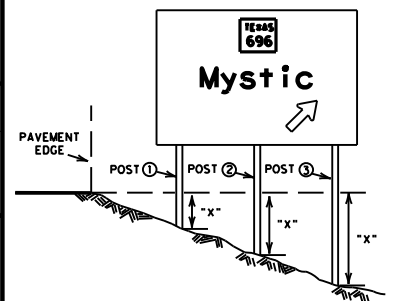

The "x" dimension is the elevation difference at the post between the ground and the edge of pavement or top of curb.

Sign supports shall be located as shown on the plans, except that the Engineer may shift the sign supports, within design guidelines, where necessary to secure a more desirable location or to avoid conflict with utilities. Unless otherwise shown on the plans, the Contractor shall stake and the Engineer will verify all sign support locations.

The post lengths listed here are approximations. The corrected post lengths will be furnished by the Contractor after the stud posts are placed.

Tower heights shall be verified with the Engineer before fabrication.

* This column is for aluminum Type A and not direct apply. Direct apply is subsidiary to the sign.

SIGN TYPE

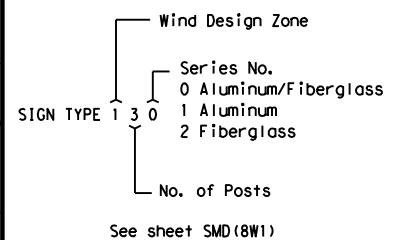

SUMMARY OF LARGE SIGNS

SHEET 24 of 35 SOLS

© TxDOT May 1987			
DN.: TxDOT		REVISIONS	
11-93	1-04		
8-95	9-08		
5-01			
CONT.	SECT.	JOB.	HIGHWAY
0095	14	033, ETC	IH 20
DIST.		COUNTY	SHEET NO.
DALLAS		VARIOUS	31

SUMMARY OF LARGE SIGNS

DISCLAIMER: The use of this standard is governed by the "Texas Engineering Practice Act". No warranty of any kind is made by TxDOT for any purpose whatsoever. TxDOT assumes no responsibility for the conversion of this standard to other formats or for incorrect results or damages resulting from its use.

DATE: 11/17/2023 2:28:41 PM
 FILE: T:\DAL\TRAFFM\FY 2023_PS8E\IH 20\Plan_Set\IH 20_Signing\IH 20_SOL5-1.dgn

PLAN SHEET NO.	SIGN NO.	SIGN BACK-GROUND COLOR	SIGN TEXT IH 20 (CSJ:0095-13-044)	SIGN DIMENSIONS	STATE SUPPLIED SF	OVERHEAD (TYPE O) SF	GROUND MOUNT (TYPE G) SF	PLAQUES, & OTHER ATTACHMENTS		REPLACE			TYPE OF MOUNT	GALVANIZED STRUCTURAL STEEL				DRILLED SHAFT			
								DIRECT APPLY	* ALUMINUM (TYPE A)	ALUM TY A (TYPE A)	GROUND MOUNT (TYPE G)	OVERHEAD (TYPE O)		SIZE	post ①	post ②	post ③	TOTAL WEIGHT	NON-REINF	REINFORCED 24"φ 30"φ 48"φ	
57	1	GREEN	<div style="border: 1px solid black; padding: 5px; width: fit-content;"> <p style="text-align: center;">EXIT 483</p> <p style="text-align: center; font-size: 1.2em;">Lawson Rd Lasater Rd</p> <p style="text-align: center;">1 MILE</p> </div>	8'0" x 2'6" 14'0" x 8'0"																	
58	1	GREEN	<div style="border: 1px solid black; padding: 5px; width: fit-content;"> <p style="text-align: center; font-size: 1.2em;">Lawson Rd Lasater Rd</p> <p style="text-align: center;">1 3/4</p> <hr/> <p style="text-align: center; font-size: 1.2em;">Belt Line Rd</p> <p style="text-align: center;">2 3/4</p> </div>	19'0" x 8'0"																	
58	2	GREEN	<div style="border: 1px solid black; padding: 5px; width: fit-content;"> <p style="text-align: center; font-size: 1.2em;">NO TRUCKS LEFT LANE</p> </div>	12'0" x 5'0"																	
END IH 20 (CSJ:0095-13-044)				PAGE TOTALS						00.00	00.00	344.00									
BEGIN IH 20 (CSJ:0095-14-033)				CSJ TOTALS						52	445.25	3466.5									
61	4	WHITE	<div style="border: 1px solid black; padding: 5px; width: fit-content;"> <p style="text-align: center; font-size: 1.2em;">AHEAD</p> <div style="border: 1px solid black; padding: 5px; width: fit-content;"> <p style="text-align: center; font-size: 1.2em;">NO TRUCKS LEFT LANE</p> </div> </div>	12'0" x 7'0"																	
61	5	WHITE	<div style="border: 1px solid black; padding: 5px; width: fit-content;"> <p style="text-align: center; font-size: 1.2em;">END</p> <div style="border: 1px solid black; padding: 5px; width: fit-content;"> <p style="text-align: center; font-size: 1.2em;">NO TRUCKS LEFT LANE</p> </div> </div>	12'0" x 7'0"																	
PAGE TOTALS																					

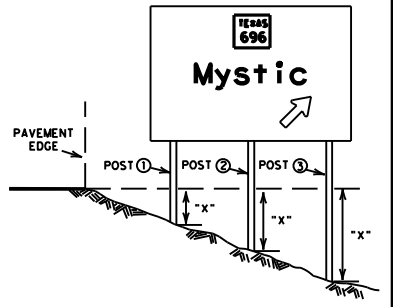

⊙ The "X" dimension is the elevation difference at the post between the ground and the edge of pavement or top of curb.

Sign supports shall be located as shown on the plans, except that the Engineer may shift the sign supports, within design guidelines, where necessary to secure a more desirable location or to avoid conflict with utilities. Unless otherwise shown on the plans, the Contractor shall stake and the Engineer will verify all sign support locations.

The post lengths listed here are approximations. The corrected post lengths will be furnished by the Contractor after the stud posts are placed.

Tower heights shall be verified with the Engineer before fabrication.

* This column is for aluminum Type A and not direct apply. Direct apply is subsidiary to the sign.

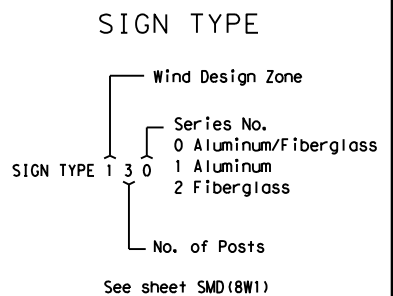

SUMMARY OF LARGE SIGNS

SOLS

SHEET 25 of 35

© TxDOT May 1987

DN: TxDOT	REVISIONS
CR: TxDOT	11-93 1-04
DR: TxDOT	8-95 9-08
CR: TxDOT	5-01

CONT	SECT	JOB	HIGHWAY
0095	14	033, ETC	IH 20
DIST	COUNTY		SHEET NO.
DALLAS	VARIOUS		32

19

DISCLAIMER: The use of this standard is governed by the "Texas Engineering Practice Act". No warranty of any kind is made by TxDOT for any purpose whatsoever. TxDOT assumes no responsibility for the conversion of this standard to other formats or for incorrect results or damages resulting from its use.

DATE: 11/17/2023 2:28:43 PM
 FILE: T:\DAL\TRAFFIC\2023_PS&E\IH 20\Plan_Set\IH 20_Signing\IH 20_SOLS-1.dgn

SUMMARY OF LARGE SIGNS

PLAN SHEET NO.	SIGN NO.	SIGN BACK-GROUND COLOR	SIGN TEXT IH 20 (CSJ:0095-13-044)	SIGN DIMENSIONS	STATE SUPPLIED SF	OVERHEAD (TYPE O) SF	GROUND MOUNT (TYPE G) SF	PLAQUES, & OTHER ATTACHMENTS		REPLACE			TYPE OF MOUNT	GALVANIZED STRUCTURAL STEEL				DRILLED SHAFT				
								DIRECT APPLY	* ALUMINUM (TYPE A)	ALUM TY A (TYPE A)	GROUND MOUNT (TYPE G)	OVERHEAD (TYPE O)		SIZE	post ①	post ②	post ③	TOTAL WEIGHT	NON-REINF	REINFORCED 24"φ 30"φ 48"φ		
67	4	GREEN	EXIT 490	8'0" x 2'6"			20.00						321	W6X9	21.50	22.21	460	10				
			FM 741	47" x 36"			11.75															
			↑	8'0" x 9'0"			72.00															
69	5	GREEN	EXIT 491	8'0" x 2'6"			20.00						321	W6X15	22.55	23.44	726	12				
			FM 2932	63" x 36"			15.75															
			Helms Tr ↑	9'0" x 10'6"			94.50															
70	4	GREEN	EXIT 490	8'0" x 2'6"			20.00						321	W6X9	19.71	18.90	414	10				
			FM 741	39" x 36"			9.75															
			1 MILE	8'0" x 7'6"			60.00															
71	4	GREEN	EXIT 493	8'0" x 2'6"			20.00						321	W6X9	19.83	19.46	421	10				
			FM 1641	50" x 36"			12.50															
			1 MILE	8'0" x 7'6"			60.00															
73	4	GREEN	EXIT 493	8'0" x 2'6"			20.00						321	W6X12	22.10	23.29	626	11				
			FM 1641	50" x 36"			12.50															
			↑	8'0" x 9'0"			72.00															
74	2	GREEN	EXIT 493	8'0" x 2'6"			20.00						321	W6X9	21.08	21.58	451	10				
			FM 1641	50" x 36"			12.50															
			↑	8'0" x 9'0"			72.00															
76	1	GREEN	EXIT 493	8'0" x 2'6"			20.00						321	W6X9	20.48	21.25	442	10				
			FM 1641	50" x 36"			12.50															
			1 MILE	8'0" x 7'6"			60.00															
PAGE TOTALS							630.50										PAGE TOTALS	3540	73			

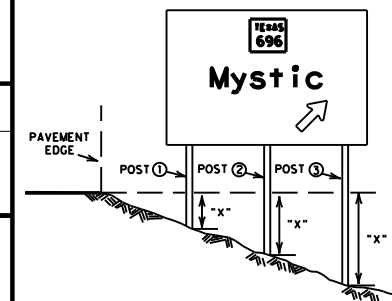

⊙ The "x" dimension is the elevation difference at the post between the ground and the edge of pavement or top of curb.
 Sign supports shall be located as shown on the plans, except that the Engineer may shift the sign supports, within design guidelines, where necessary to secure a more desirable location or to avoid conflict with utilities. Unless otherwise shown on the plans, the Contractor shall stake and the Engineer will verify all sign support locations.
 The post lengths listed here are approximations. The corrected post lengths will be furnished by the Contractor after the stud posts are placed.
 Tower heights shall be verified with the Engineer before fabrication.

* This column is for aluminum Type A and not direct apply. Direct apply is subsidiary to the sign.

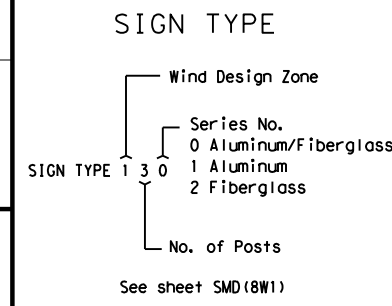

SUMMARY OF LARGE SIGNS
SOLS
 SHEET 26 of 35

© TxDOT May 1987

DN: TxDOT	REVISIONS
CR: TxDOT	11-93 1-04
DN: TxDOT	8-95 9-08
CR: TxDOT	5-01

CONT	SECT	JOB	HIGHWAY
0095	14	033, ETC	IH 20
DIST	COUNTY		SHEET NO.
DALLAS	VARIOUS		33

19

SUMMARY OF LARGE SIGNS

PLAN SHEET NO.	SIGN NO.	SIGN BACK-GROUND COLOR	SIGN TEXT IH 20 (CSJ:0095-14-033)	SIGN DIMENSIONS	STATE SUPPLIED SF	OVERHEAD (TYPE O) SF	GROUND MOUNT (TYPE G) SF	PLAQUES, & OTHER ATTACHMENTS		REPLACE			TYPE OF MOUNT	GALVANIZED STRUCTURAL STEEL				DRILLED SHAFT				
								DIRECT APPLY	* ALUMINUM (TYPE A)	ALUM TY A (TYPE A)	GROUND MOUNT (TYPE G)	OVERHEAD (TYPE O)		SIZE	post ①	post ②	post ③	TOTAL WEIGHT	NON-REINF	REINFORCED 24"φ 30"φ 48"φ		
80	3	GREEN		2'6" x 2'6" 8'0" x 2'6" 41" x 36" 8'0" x 7'6"			20.00 60.00			6.25			321	W6X9	18.87	18.29		401		10		
82	5	GREEN		2'6" x 2'6" 8'0" x 2'6" 41" x 36" 8'0" x 9'0"			20.00 72.00			6.25			321	W6X9	18.77	19.25		409		10		
82	9	GREEN		10'0" x 2'6" 16'0" x 6'0"																		
84	3	GREEN		2'6" x 2'6" 8'0" x 2'6" 41" x 36" 8'0" x 7'6"			20.00 60.00			6.25			321	W6X9	19.33	20.00		421		10		
84	4	GREEN		36" x 36" 17'0" x 10'6"						9.00												178.50
PAGE TOTALS							252.00			18.75	121	178.5	PAGE TOTALS				1231		30			

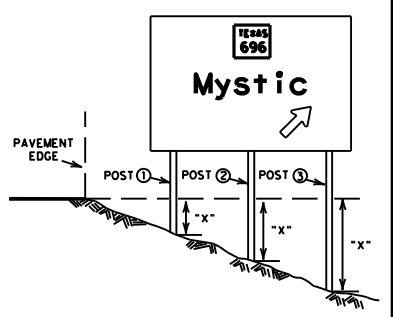

⊙ The "x" dimension is the elevation difference at the post between the ground and the edge of pavement or top of curb.

Sign supports shall be located as shown on the plans, except that the Engineer may shift the sign supports, within design guidelines, where necessary to secure a more desirable location or to avoid conflict with utilities. Unless otherwise shown on the plans, the Contractor shall stake and the Engineer will verify all sign support locations.

The post lengths listed here are approximations. The corrected post lengths will be furnished by the Contractor after the stud posts are placed.

Tower heights shall be verified with the Engineer before fabrication.

* This column is for aluminum Type A and not direct apply. Direct apply is subsidiary to the sign.

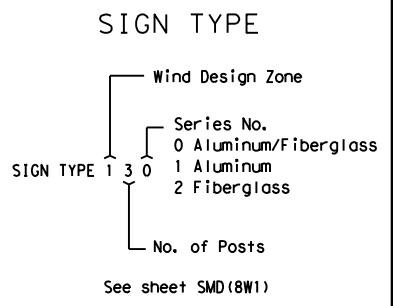

SUMMARY OF LARGE SIGNS
SOLS

SHEET 27 of 35

© TxDOT May 1987

DN. - TxDOT	REVISIONS
CR. - TxDOT	11-93 1-04
DN. - TxDOT	8-95 9-08
CR. - TxDOT	5-01

CONT	SECT	JOB	HIGHWAY
0095	14	033, ETC	IH 20
DIST	COUNTY		SHEET NO.
DALLAS	VARIOUS		34

19

DISCLAIMER: The use of this standard is governed by the "Texas Engineering Practice Act". No warranty of any kind is made by TxDOT for any purpose whatsoever. TxDOT assumes no responsibility for the conversion of this standard to other formats or for incorrect results or damages resulting from its use.
 DATE: 11/17/2023 2:28:46 PM
 FILE: T:\DAL\TRAFFIC\2023_PS&E\IH 20\Plan Set\IH 20_Signing\IH 20_SOLS-1.dgn

SUMMARY OF LARGE SIGNS

PLAN SHEET NO.	SIGN NO.	SIGN BACK-GROUND COLOR	SIGN TEXT	SIGN DIMENSIONS	STATE SUPPLIED SF	OVERHEAD (TYPE O) SF	GROUND MOUNT (TYPE G) SF	PLAQUES, & OTHER ATTACHMENTS		REPLACE			TYPE OF MOUNT	GALVANIZED STRUCTURAL STEEL				DRILLED SHAFT			
								DIRECT APPLY	* ALUMINUM (TYPE A)	ALUM TY A (TYPE A)	GROUND MOUNT (TYPE G)	OVERHEAD (TYPE O)		SIZE	post ①	post ②	post ③	TOTAL WEIGHT	NON-REINF	REINFORCED	
			IH 20 (CSJ:0095-14-033)																		
84	5	GREEN	EXIT 499 A TO 80 WEST Dallas	10'0" x 2'6" 36" x 36" 17'0" x 10'6"				9.00													
84	6	GREEN	EAST 20 Shreveport	36" x 36" 17'6" x 10'6"				9.00													
84	7	GREEN	EXIT 499 B Rose Hill Rd	10'0" x 2'6" 12'0" x 6'6"																	
			END IH 20 (CSJ:0095-14-033)	PAGE TOTALS																	
			BEGIN IH 20 (CSJ:0495-01-079)	CSJ TOTALS			882.5		18.75	121	826.75					4771		103			
85	1	GREEN	Forney Mesquite EXIT 499A	10'6" x 7'0"			84.00					321	W6X9	15.95	16.97		363		10		
85	4	GREEN	EXIT 499 A TO 80 WEST Dallas 1/2 MILE	10'0" x 2'6" 36" x 36" 15'0" x 10'0"				9.00													
85	6	GREEN	EXIT 499 B Rose Hill Rd	10'0" x 2'6" 12'0" x 6'6"																	
			PAGE TOTALS				84.00														
			PAGE TOTALS								278.00										
			PAGE TOTALS														363		10		

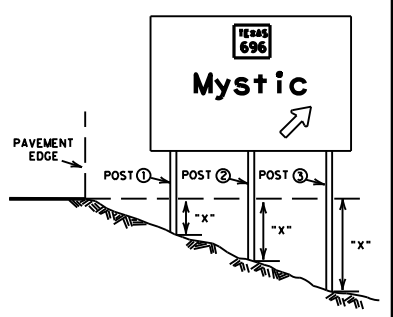

⊖ The "X" dimension is the elevation difference at the post between the ground and the edge of pavement or top of curb.

Sign supports shall be located as shown on the plans, except that the Engineer may shift the sign supports, within design guidelines, where necessary to secure a more desirable location or to avoid conflict with utilities. Unless otherwise shown on the plans, the Contractor shall stake and the Engineer will verify all sign support locations.

The post lengths listed here are approximations, The corrected post lengths will be furnished by the Contractor after the stud posts are placed.

Tower heights shall be verified with the Engineer before fabrication.

* This column is for aluminum Type A and not direct apply. Direct apply is subsidiary to the sign.

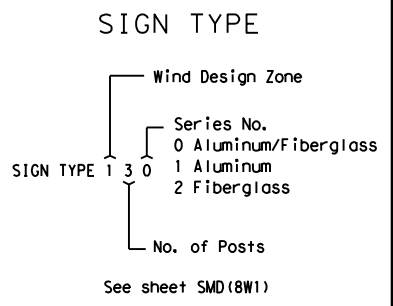

SUMMARY OF LARGE SIGNS

SHEET 28 of 35 SOLS

© TxDOT May 1987

REV.	DATE	BY	REVISIONS
1	11-93		1-04
2	8-95		9-08
3	5-01		

CONT	SECT	JOB	HIGHWAY
0095	14	033, ETC	IH 20
DIST	COUNTY	SHEET NO.	
DALLAS	VARIOUS	35	

DISCLAIMER: The use of this standard is governed by the "Texas Engineering Practice Act". No warranty of any kind is made by TxDOT for any purpose whatsoever. TxDOT assumes no responsibility for the conversion of this standard to other formats or for incorrect results or damages resulting from its use.
 DATE: 11/17/2023 2:28:48 PM
 FILE: T:\DAL\TRAFFIC\2023_PS&E\IH 20\Plan_Set\IH 20_Signing\IH 20_SOLS-1.dgn

SUMMARY OF LARGE SIGNS

PLAN SHEET NO.	SIGN NO.	SIGN BACK-GROUND COLOR	SIGN TEXT IH 20 (CSJ:0495-01-079)	SIGN DIMENSIONS	STATE SUPPLIED SF	OVERHEAD (TYPE O) SF	GROUND MOUNT (TYPE G) SF	PLAQUES, & OTHER ATTACHMENTS		REPLACE			TYPE OF MOUNT	GALVANIZED STRUCTURAL STEEL				DRILLED SHAFT			
								DIRECT APPLY	* ALUMINUM (TYPE A)	ALUM TY A (TYPE A)	GROUND MOUNT (TYPE G)	OVERHEAD (TYPE O)		SIZE	post ①	post ②	post ③	TOTAL WEIGHT	NON-REINF	REINFORCED 24"φ 30"φ 48"φ	
85	9	GREEN		3'0" x 3'0" 36" x 36" 8'0" x 2'6" 11'6" x 12'0"			20.00 138.00	9.00		6.25		321	W6X15	20.75	21.07		663		12		
87	2	GREEN		10'0" x 2'6" 36" x 36" 15'0" x 10'0"				9.00					INSTALL ON EXISTING COSS								
87	3	GREEN		10'0" x 2'6" 15'6" x 6'0"																	
87	5	GREEN		3'0" x 3'0" 36" x 36" 8'0" x 2'6" 12'0" x 13'0"			20.00 156.00	9.00		9.00		321	W6X15	21.83	21.06		679		12		
89	2	GREEN		3'0" x 3'0" 36" x 36" 8'0" x 2'6" 12'0" x 13'0"			20.00 156.00	9.00		6.25		321	W6X15	22.13	21.58		692		12		
93	1	GREEN		8'0" x 2'6" 10'0" x 6'6"									INSTALL ON EXISTING SUPPORTS & FOUNDATIONS								
94	1	GREEN		8'0" x 2'6" 13'6" x 6'0"			20.00 91.00					321	W6X9	16.19	15.00		348		10		
PAGE TOTALS							621.00			21.5	85.00	293.00	PAGE TOTALS				2382		46		

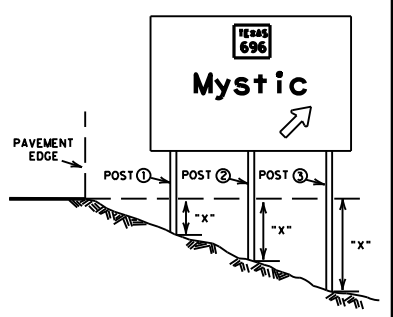

⊙ The "x" dimension is the elevation difference at the post between the ground and the edge of pavement or top of curb.

Sign supports shall be located as shown on the plans, except that the Engineer may shift the sign supports, within design guidelines, where necessary to secure a more desirable location or to avoid conflict with utilities. Unless otherwise shown on the plans, the Contractor shall stake and the Engineer will verify all sign support locations.

The post lengths listed here are approximations. The corrected post lengths will be furnished by the Contractor after the stud posts are placed.

Tower heights shall be verified with the Engineer before fabrication.

* This column is for aluminum Type A and not direct apply. Direct apply is subsidiary to the sign.

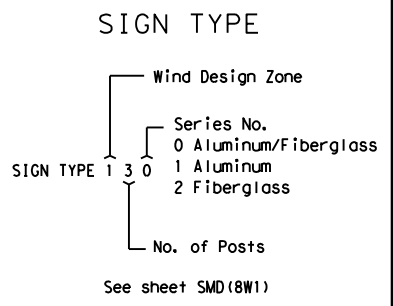

SUMMARY OF LARGE SIGNS
SOLS

SHEET 29 of 35

© TxDOT May 1987

DN. - TxDOT	REVISIONS
CK. - TxDOT	11-93 1-04
DN. - TxDOT	8-95 9-08
CK. - TxDOT	5-01

CONT	SECT	JOB	HIGHWAY
0095	14	033, ETC	IH 20
DIST	COUNTY		SHEET NO.
DALLAS	VARIOUS		36

19

DISCLAIMER: The use of this standard is governed by the "Texas Engineering Practice Act". No warranty of any kind is made by TxDOT for any purpose whatsoever. TxDOT assumes no responsibility for the conversion of this standard to other formats or for incorrect results or damages resulting from its use.
 DATE: 11/17/2023 2:28:51 PM
 FILE: T:\DAL\TRAFFIC\2023_PS&E\IH 20\Plan_Set\IH 20_Signing\IH 20_SOL5-1.dgn

SUMMARY OF LARGE SIGNS

PLAN SHEET NO.	SIGN NO.	SIGN BACK-GROUND COLOR	SIGN TEXT IH 20 (CSJ:0495-01-079)	SIGN DIMENSIONS	STATE SUPPLIED SF	OVERHEAD (TYPE O) SF	GROUND MOUNT (TYPE G) SF	PLAQUES, & OTHER ATTACHMENTS		REPLACE			GALVANIZED STRUCTURAL STEEL				DRILLED SHAFT					
								DIRECT APPLY	* ALUMINUM (TYPE A)	ALUM TY A (TYPE A)	GROUND MOUNT (TYPE G)	OVERHEAD (TYPE O)	TYPE OF MOUNT	SIZE	post ①	post ②	post ③	TOTAL WEIGHT	NON-REINF	REINFORCED 24"φ 30"φ 48"φ		
95	3	GREEN	<div style="text-align: right;">EXIT 506</div> <div style="display: flex; justify-content: space-around;"> <div style="border: 1px solid black; padding: 2px;">FM 429</div> <div style="border: 1px solid black; padding: 2px;">FM 2728</div> </div> <div style="text-align: center;">College Mound Rd 1 MILE</div>	8'0" x 2'6" 49" x 36" 63" x 36" 22'6" x 10'0"			20.00 12.25 15.75 225.00							331	W6X15	18.75	18.46	18.71	893		18	
98	2	GREEN	<div style="text-align: right;">EXIT 506</div> <div style="display: flex; justify-content: space-around;"> <div style="border: 1px solid black; padding: 2px;">FM 429</div> <div style="border: 1px solid black; padding: 2px;">FM 2728</div> </div> <div style="text-align: center;">College Mound Rd</div>	8'0" x 2'6" 49" x 36" 63" x 36" 18'6" x 11'0"			20.00 12.25 15.75 203.50							331	W6X15	20.20	20.95	21.71	997		18	
99	3	GREEN	<div style="text-align: right;">EXIT 506</div> <div style="display: flex; justify-content: space-around;"> <div style="border: 1px solid black; padding: 2px;">FM 429</div> <div style="border: 1px solid black; padding: 2px;">FM 2728</div> </div> <div style="text-align: center;">College Mound Rd 1 MILE</div>	8'0" x 2'6" 49" x 36" 63" x 36" 22'6" x 10'0"			20.00 12.25 15.75 225.00							331	W6X15	20.04	21.00	22.13	1001		18	
100	1	GREEN	<div style="text-align: right;">EXIT 509</div> <div style="border: 1px solid black; padding: 5px; text-align: center;">Hiram Rd 1 MILE</div>	8'0" x 2'6" 12'6" x 6'0"			20.00 75.00							321	W6X9	14.0	16.43		341		10	
102	1	GREEN	<div style="text-align: right;">EXIT 509</div> <div style="border: 1px solid black; padding: 5px; text-align: center;">Hiram Rd</div>	8'0" x 2'6" 12'6" x 7'0"			20.00 87.50							321	W6X9	16.67	17.13		371		10	
103	6	GREEN	<div style="text-align: right;">EXIT 509</div> <div style="border: 1px solid black; padding: 5px; text-align: center;">Hiram Rd</div>	8'0" x 2'6" 12'6" x 7'0"			20.00 87.50							321	W6X9	15.88	15.88		353		10	
105	3	GREEN	<div style="text-align: right;">EXIT 509</div> <div style="border: 1px solid black; padding: 5px; text-align: center;">Hiram Rd 1 MILE</div>	8'0" x 2'6" 12'6" x 6'0"			20.00 75.00							321	W6X9	14.24	14.74		328		10	
PAGE TOTALS							1118.50												PAGE TOTALS	4284	94	

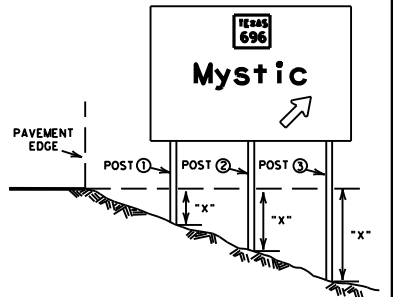

⊙ The "x" dimension is the elevation difference at the post between the ground and the edge of pavement or top of curb.

Sign supports shall be located as shown on the plans, except that the Engineer may shift the sign supports, within design guidelines, where necessary to secure a more desirable location or to avoid conflict with utilities. Unless otherwise shown on the plans, the Contractor shall stake and the Engineer will verify all sign support locations.

The post lengths listed here are approximations. The corrected post lengths will be furnished by the Contractor after the stud posts are placed.

Tower heights shall be verified with the Engineer before fabrication.

* This column is for aluminum Type A and not direct apply. Direct apply is subsidiary to the sign.

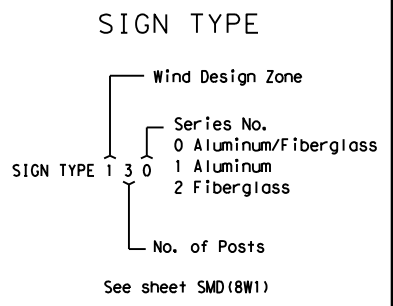

SUMMARY OF LARGE SIGNS

SOLS

SHEET 30 of 35

© TxDOT May 1987

DN: TxDOT	REVISIONS
CR: TxDOT	11-93 1-04
DR: TxDOT	8-95 9-08
CR: TxDOT	5-01

CONT	SECT	JOB	HIGHWAY
0095	14	033, ETC	IH 20
DIST	COUNTY		SHEET NO.
DALLAS	VARIOUS		37

19

DISCLAIMER: The use of this standard is governed by the "Texas Engineering Practice Act". No warranty of any kind is made by TxDOT for any purpose whatsoever. TxDOT assumes no responsibility for the conversion of this standard to other formats or for incorrect results or damages resulting from its use.
 DATE: 11/17/2023 2:29:10 PM
 FILE: T:\DAL\TRAFFIC\2023_PSBE\IH 20\Plan_Set\IH 20_Signing\IH 20_SOLS-1.dgn

DISCLAIMER: The use of this standard is governed by the "Texas Engineering Practice Act". No warranty of any kind is made by TxDOT for any purpose whatsoever. TxDOT assumes no responsibility for the conversion of this standard to other formats or for incorrect results or damages resulting from its use.

DATE: 11/17/2023 2:29:13 PM
 FILE: T:\DAL\TRAFFIC\2023_PS&E\IH 20\Plan_Set\IH 20_Signing\IH 20_SOLS-1.dgn

SUMMARY OF LARGE SIGNS

PLAN SHEET NO.	SIGN NO.	SIGN BACK-GROUND COLOR	SIGN TEXT IH 20 (CSJ:0495-01-079)	SIGN DIMENSIONS	STATE SUPPLIED SF	OVERHEAD (TYPE O) SF	GROUND MOUNT (TYPE G) SF	PLAQUES, & OTHER ATTACHMENTS		REPLACE			GALVANIZED STRUCTURAL STEEL				DRILLED SHAFT					
								DIRECT APPLY	* ALUMINUM (TYPE A)	ALUM TY A (TYPE A)	GROUND MOUNT (TYPE G)	OVERHEAD (TYPE O)	TYPE OF MOUNT	SIZE	post ①	post ②	post ③	TOTAL WEIGHT	NON-REINF	REINFORCED 24"φ 30"φ 48"φ		
107	3	GREEN	EXIT 512 FM 2965 1 MILE	8'0" x 2'6" 64" x 36" 8'0" x 7'6"			20.00 16.00 60.00					321	W6X9	19.42	19.96		421		10			
108	2	GREEN	EXIT 512 FM 2965 ↑	8'0" x 2'6" 64" x 36" 8'0" x 9'0"			20.00 16.00 72.00					321	W6X12	22.38	23.83		561		11			
110	1	GREEN	EXIT 512 FM 2965 ↑	8'0" x 2'6" 64" x 36" 8'0" x 9'0"			20.00 16.00 72.00					321	W6X9	21.04	21.25		448		10			
END IH 20 (CSJ:0495-01-079)				PAGE TOTALS			264.00										1430		31			
CSJ TOTALS									2087.50			21.50	85.00	571.00	PAGE TOTALS			8096		171		

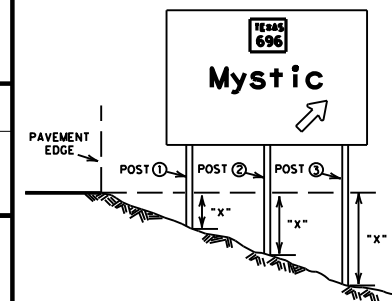

⊙ The "x" dimension is the elevation difference at the post between the ground and the edge of pavement or top of curb.
 Sign supports shall be located as shown on the plans, except that the Engineer may shift the sign supports, within design guidelines, where necessary to secure a more desirable location or to avoid conflict with utilities. Unless otherwise shown on the plans, the Contractor shall stake and the Engineer will verify all sign support locations.
 The post lengths listed here are approximations. The corrected post lengths will be furnished by the Contractor after the stud posts are placed.
 Tower heights shall be verified with the Engineer before fabrication.

* This column is for aluminum Type A and not direct apply. Direct apply is subsidiary to the sign.

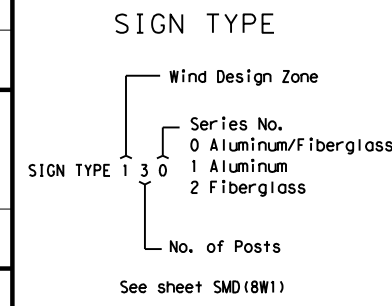

SUMMARY OF LARGE SIGNS
SOLS

SHEET 31 of 35

© TxDOT May 1987

DN: TxDOT	REVISIONS
CR: TxDOT	11-93 1-04
DN: TxDOT	8-95 9-08
CR: TxDOT	5-01







CONT	SECT	JOB	HIGHWAY
0095	14	033, ETC	IH 20
DIST	COUNTY		SHEET NO.
DALLAS	VARIOUS		38

19

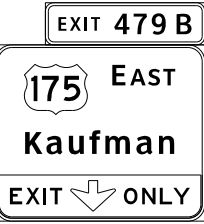
DISCLAIMER: The use of this standard is governed by the "Texas Engineering Practice Act". No warranty of any kind is made by TxDOT for any purpose whatsoever. TxDOT assumes no responsibility for the conversion of this standard to other formats or for incorrect results or damages resulting from its use.

DATE: 11/17/2023 2:29:15 PM
FILE: T:\DAL\TRAFFIC\FY 2023_PS&E\IH 20\Plan_Set\IH 20_Signing\IH 20_SOLs-1.dgn

SUMMARY OF LARGE SIGNS

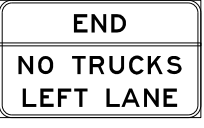
PLAN SHEET NO.	SIGN NO.	SIGN BACK-GROUND COLOR	SIGN TEXT IH 635 (CSJ:2374-02-157)	SIGN DIMENSIONS	STATE SUPPLIED SF	OVERHEAD (TYPE O) SF	GROUND MOUNT (TYPE G) SF	PLAQUES, & OTHER ATTACHMENTS		REPLACE			TYPE OF MOUNT	GALVANIZED STRUCTURAL STEEL				DRILLED SHAFT				
								DIRECT APPLY	* ALUMINUM (TYPE A)	ALUM TY A (TYPE A)	GROUND MOUNT (TYPE G)	OVERHEAD (TYPE O)		SIZE	post ①	post ②	post ③	TOTAL WEIGHT	NON-REINF	REINFORCED		
																	24"φ	30"φ	48"φ			
112	5	GREEN		3'0" X 3'0" 36" X 36" 12'0" X 7'6"				9.00		9.00												
112	6	GREEN YELLOW		10'0" X 2'6" 45" X 36" 150" X 30" 12'6" X 10'6"				11.25 30.00		25.00 131.25												
112	7	YELLOW		11'6" X 6'6"						74.75												
112	8	GREEN		7'6" X 2'6" 36" X 36" 14'6" X 10'6"				9.00		18.75 152.25												
112	11	GREEN		7'6" X 2'6" 11'6" X 6'0"						18.75 69.00												
112	12	GREEN		7'6" X 2'6" 13'6" X 6'6"						18.75 87.75												
112	14	GREEN		60" X 48" 13'0" X 5'0"				20.00		65.00												
113	1	WHITE		12'6" X 9'6"						118.75												
113	2	WHITE		12'0" X 7'0"						84.00												
PAGE TOTALS									9.00	65.00	889.00											
													PAGE TOTALS									

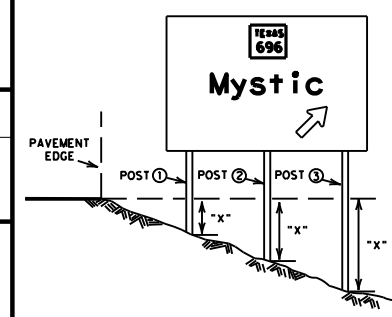

⊙ The "x" dimension is the elevation difference at the post between the ground and the edge of pavement or top of curb.
Sign supports shall be located as shown on the plans, except that the Engineer may shift the sign supports, within design guidelines, where necessary to secure a more desirable location or to avoid conflict with utilities. Unless otherwise shown on the plans, the Contractor shall stake and the Engineer will verify all sign support locations.
The post lengths listed here are approximations. The corrected post lengths will be furnished by the Contractor after the stud posts are placed.
Tower heights shall be verified with the Engineer before fabrication.

* This column is for aluminum Type A and not direct apply. Direct apply is subsidiary to the sign.

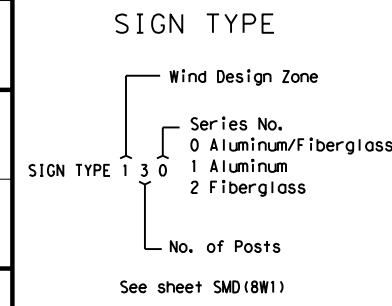

SUMMARY OF LARGE SIGNS

SOLS

SHEET 32 of 35





© TxDOT Mgy. 1987		REVISIONS	
DN.-TxDOT	11-93	1-04	
CR.-TxDOT	8-95	9-08	
DN.-TxDOT	5-01		
CR.-TxDOT			
CONT	SECT	JOB	HIGHWAY
0095	14	033, ETC	IH 20
DIST	COUNTY		SHEET NO.
DALLAS	VARIOUS		39

19

DISCLAIMER: The use of this standard is governed by the "Texas Engineering Practice Act". No warranty of any kind is made by TxDOT for any purpose whatsoever. TxDOT assumes no responsibility for the conversion of this standard to other formats or for incorrect results or damages resulting from its use.

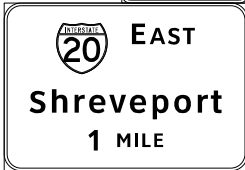
DATE: 11/17/2023 2:29:17 PM
 FILE: T:\DAL\TRAFFIC\2023 PS&E\IH 20VPlan_Set\IH 20 Signing\IH 20 SOLS-1.dgn

SUMMARY OF LARGE SIGNS

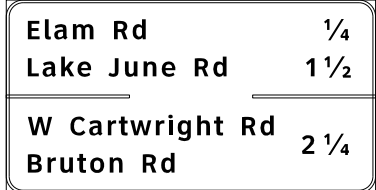
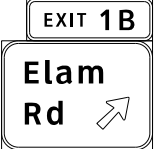
PLAN SHEET NO.	SIGN NO.	SIGN BACK-GROUND COLOR	SIGN TEXT IH 635 (CSJ:2374-02-157)	SIGN DIMENSIONS	STATE SUPPLIED SF	OVERHEAD (TYPE O) SF	GROUND MOUNT (TYPE G) SF	PLAQUES, & OTHER ATTACHMENTS		REPLACE			TYPE OF MOUNT	GALVANIZED STRUCTURAL STEEL				DRILLED SHAFT						
								DIRECT APPLY	* ALUMINUM (TYPE A)	ALUM TY A (TYPE A)	GROUND MOUNT (TYPE G)	OVERHEAD (TYPE O)		SIZE	post ①	post ②	post ③	TOTAL WEIGHT	NON-REINF	REINFORCED 24"ϕ 30"ϕ 48"ϕ				
113	3	GREEN	<div style="border: 1px solid black; padding: 5px; text-align: center;"> EXIT 479 B-A  </div>	12'0" X 2'6" 45" X 36" 12'0" X 12'0"																				
113	4	GREEN	<div style="border: 1px solid black; padding: 5px; text-align: center;"> EXIT 1C  </div>	7'6" X 2'6" 36" X 36" 14'6" X 10'0"																				
113	5	GREEN	<div style="border: 1px solid black; padding: 5px; text-align: center;"> EXIT 1A  </div>	7'6" X 2'6" 13'6" X 6'6"																				
113	6	GREEN	<div style="border: 1px solid black; padding: 5px; text-align: center;">  </div>	36" X 36" 30" X 24" 19'6" X 10'0"																				
113	7	GREEN	<div style="border: 1px solid black; padding: 5px; text-align: center;">  </div>	45" X 36" 14'0" X 10'0"																				
113	8	GREEN	<div style="border: 1px solid black; padding: 5px; text-align: center;">  </div>	23'0" X 11'0"																				
114	4	GREEN	<div style="border: 1px solid black; padding: 5px; text-align: center;"> EXIT 1B  </div>	7'6" X 2'6" 9'0" X 6'6"																				
PAGE TOTALS																								
											140.00	969.50	PAGE TOTALS											

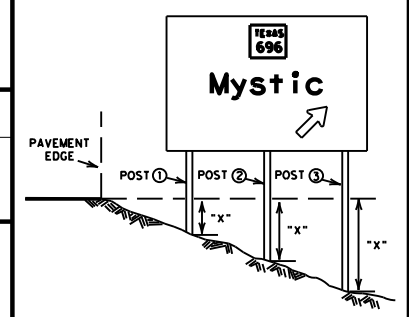

⊖ The "x" dimension is the elevation difference at the post between the ground and the edge of pavement or top of curb.
 Sign supports shall be located as shown on the plans, except that the Engineer may shift the sign supports, within design guidelines, where necessary to secure a more desirable location or to avoid conflict with utilities. Unless otherwise shown on the plans, the Contractor shall stake and the Engineer will verify all sign support locations.
 The post lengths listed here are approximations. The corrected post lengths will be furnished by the Contractor after the stud posts are placed.
 Tower heights shall be verified with the Engineer before fabrication.

* This column is for aluminum Type A and not direct apply. Direct apply is subsidiary to the sign.

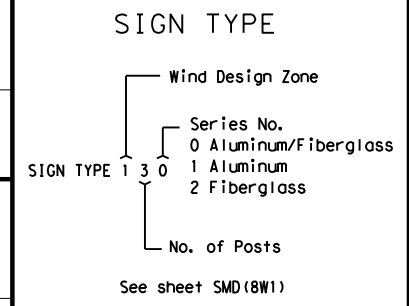

SUMMARY OF LARGE SIGNS

SOLS

SHEET 33 of 35

© TxDOT Mgy. 1987		REVISIONS	
DN.-TxDOT	11-93	1-04	
CK.-TxDOT	8-95	9-08	
DN.-TxDOT	5-01		
CK.-TxDOT			
CONT	SECT	JOB	HIGHWAY
0095	14	033, ETC	IH 20
DIST	COUNTY		SHEET NO.
DALLAS	VARIOUS		40

19

SUMMARY OF LARGE SIGNS

PLAN SHEET NO.	SIGN NO.	SIGN BACK-GROUND COLOR	SIGN TEXT IH 635 (CSJ:2374-02-157)	SIGN DIMENSIONS	STATE SUPPLIED SF	OVERHEAD (TYPE O) SF	GROUND MOUNT (TYPE G) SF	PLAQUES, & OTHER ATTACHMENTS		REPLACE			TYPE OF MOUNT	GALVANIZED STRUCTURAL STEEL				DRILLED SHAFT													
								DIRECT APPLY	* ALUMINUM (TYPE A)	ALUM TY A (TYPE A)	GROUND MOUNT (TYPE G)	OVERHEAD (TYPE O)		SIZE	post 1	post 2	post 3	TOTAL WEIGHT	NON-REINF	REINFORCED											
115	1	GREEN		36" X 36" 20'0" X 9'0"				9.00																							
115	2	GREEN		23'0" X 8'6"																											
116	3	GREEN		6'0" X 2'6" 13'6" X 6'6"																											
117	3	GREEN		20'6" X 7'0"																											
117	7	WHITE		12'0" X 5'0"																											
117	8	WHITE		12'0" X 5'0"																											
117	9	GREEN		6'0" X 2'6" 48" X 36" 17'0" X 12'0"				12.00																							
PAGE TOTALS																															
												960.75	PAGE TOTALS																		

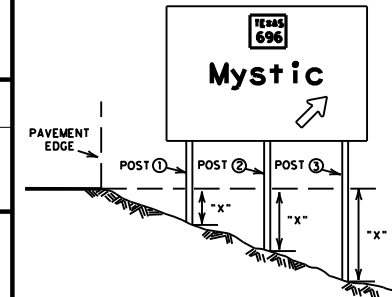

The "x" dimension is the elevation difference at the post between the ground and the edge of pavement or top of curb.

Sign supports shall be located as shown on the plans, except that the Engineer may shift the sign supports, within design guidelines, where necessary to secure a more desirable location or to avoid conflict with utilities. Unless otherwise shown on the plans, the Contractor shall stake and the Engineer will verify all sign support locations.

The post lengths listed here are approximations. The corrected post lengths will be furnished by the Contractor after the stud posts are placed.

Tower heights shall be verified with the Engineer before fabrication.

* This column is for aluminum Type A and not direct apply. Direct apply is subsidiary to the sign.

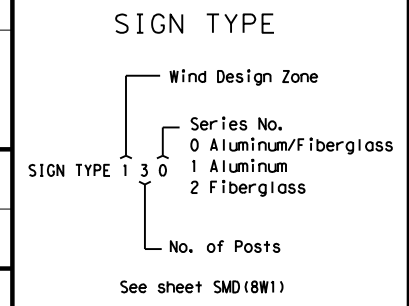

SUMMARY OF LARGE SIGNS

SOLS

SHEET 34 of 35

© TxDOT May, 1987

DN.-TxDOT
CK.-TxDOT
DN.-TxDOT
CK.-TxDOT

11-93	1-04
8-95	9-08
5-01	





CONT	SECT	JOB	HIGHWAY
0095	14	033, ETC	IH 20
DIST	COUNTY		SHEET NO.
DALLAS	VARIOUS		41

19

DATE: 11/17/2023 2:29:20 PM
 FILE: T:\DAL\TRAFFIC\2023_PSBE\IH 20VPlan_Set\IH 20 Signing\IH 20 SOLS-1.dgn
 DISCLAIMER: The use of this standard is governed by the "Texas Engineering Practice Act". No warranty of any kind is made by TxDOT for any purpose whatsoever. TxDOT assumes no responsibility for the conversion of this standard to other formats or for incorrect results or damages resulting from its use.

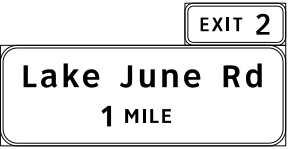
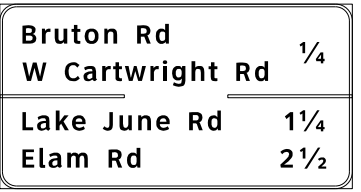
DATE: 11/17/2023 2:29:22 PM
 FILE: T:\DAL\TRAFFM\FY 2023_PSBE\IH 20\Plan_Set\IH 20_Signing\IH 20_SOLS-1.dgn
 DISCLAIMER: The use of this standard is governed by the "Texas Engineering Practice Act". No warranty of any kind is made by TxDOT for any purpose whatsoever. TxDOT assumes no responsibility for the conversion of this standard to other formats or for incorrect results or damages resulting from its use.

SUMMARY OF LARGE SIGNS

PLAN SHEET NO.	SIGN NO.	SIGN BACK-GROUND COLOR	SIGN TEXT IH 635 (CSJ: 2374-02-157)	SIGN DIMENSIONS	STATE SUPPLIED SF	OVERHEAD (TYPE O) SF	GROUND MOUNT (TYPE G) SF	PLAQUES, & OTHER ATTACHMENTS		REPLACE			TYPE OF MOUNT	GALVANIZED STRUCTURAL STEEL				DRILLED SHAFT						
								DIRECT APPLY	* ALUMINUM (TYPE A)	ALUM TY A (TYPE A)	GROUND MOUNT (TYPE G)	OVERHEAD (TYPE O)		SIZE	post 1	post 2	post 3	TOTAL WEIGHT	NON-REINF	REINFORCED 24"φ 30"φ 48"φ				
118	3	GREEN		6'0" X 2'6" 17'0" X 6'0"								15.00 102.00												
119	2	GREEN		23'6" X 11'0"								258.50												
120	2	GREEN		9'6" X 2'6" 36" X 36" 10'6" X 12'6"				9.00				23.75 131.25												
120	4	GREEN		6'0" X 2'6" 48" X 36" 17'0" X 13'0"				12.00				15.00 221.00												
121	6	GREEN		6'0" X 2'6" 20'6" X 8'6"								15.00 174.25												
121	7	GREEN		6'0" X 2'6" 48" X 36" 17'0" X 13'6"				12.00				15.00 229.50												
				PAGE TOTALS								1200.25												
				CSJ TOTALS					9.00	205.00	4019.50													
PROJECT TOTALS						127.25	3126.00		177.80	267.93	1552.5	29832.00												
													PROJECT TOTALS	13571		290.5		16						

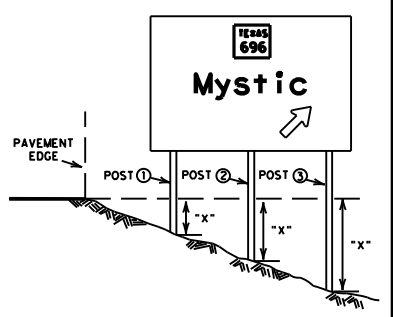

The "x" dimension is the elevation difference at the post between the ground and the edge of pavement or top of curb.
 Sign supports shall be located as shown on the plans, except that the Engineer may shift the sign supports, within design guidelines, where necessary to secure a more desirable location or to avoid conflict with utilities. Unless otherwise shown on the plans, the Contractor shall stake and the Engineer will verify all sign support locations.
 The post lengths listed here are approximations. The corrected post lengths will be furnished by the Contractor after the stud posts are placed.
 Tower heights shall be verified with the Engineer before fabrication.

* This column is for aluminum Type A and not direct apply. Direct apply is subsidiary to the sign.

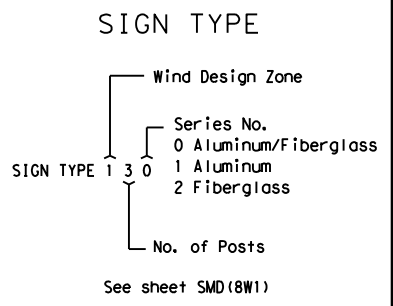













SUMMARY OF LARGE SIGNS

SHEET 35 of 35 SOLS

© TxDOT Mgy. 1987		REVISIONS	
DN: TxDOT	11-93	1-04	
CR: TxDOT	8-95	9-08	
CR: TxDOT	5-01		
CONT	SECT	JOB	HIGHWAY
0095	14	033, ETC	IH 20
DIST	COUNTY		SHEET NO.
DALLAS	VARIOUS		42

SUMMARY OF SMALL SIGNS

DISCLAIMER: The use of this standard is governed by the "Texas Engineering Practice Act". No warranty of any kind is made by TxDOT for any purpose whatsoever. TxDOT assumes no responsibility for the conversion of this standard to other formats or for incorrect results or damages resulting from its use.

PLAN SHEET NO.	SIGN NO.	SIGN NOMENCLATURE	SIGN	DIMENSIONS	FLAT ALUMINUM (TYPE A)	EXAL ALUMINUM (TYPE G)	SM RD SGN ASSM TY XXXXX (X) XX (X-XXXX)				BRIDGE MOUNT CLEARANCE SIGNS (See Note 2)	REPLACE ALUM SIGNS SF		
							POST TYPE	POSTS	ANCHOR TYPE	MOUNTING DESIGNATION		TY = TYPE	TYPE A	TYPE G
							FRP = Fiberglass TWT = Thin-Wall 10BWG = 10 BWG S80 = Sch 80	1 or 2	UA=Universal Conc UB=Universal Bolt SA=Slipbase-Conc SB=Slipbase-Bolt WS=Wedge Steel WP=Wedge Plastic	PREFABRICATED P = "Plain" T = "T" U = "U"				
			IH 20 (CSJ:2374-04-087)											
1	1	I-2dT		72 X 36	X		INSTALL	ON EXISTING MOUNT				18.0		
1	3	D10-3		12 X 48	X		INSTALL	ON EXISTING MOUNT				4.0		
1	4	D10-3		12 X 48	X		INSTALL	ON EXISTING MOUNT				4.0		
1	5	I-2dT		66 X 36	X		INSTALL	ON EXISTING MOUNT				16.5		
1	9	E5-1c		72 X 90	X		INSTALL	ON EXISTING MOUNT				45.0		
1	10	E5-1c		72 X 90	X		INSTALL	ON EXISTING MOUNT				45.0		
2	3	D10-3		12 X 48	X		INSTALL	ON EXISTING MOUNT				4.0		
2	4	D10-3		12 X 48	X		INSTALL	ON EXISTING MOUNT				4.0		
2	5	E5-1c		72 X 90	X		INSTALL	ON EXISTING MOUNT				45.0		
2	7	D1-1		96 X 18	X		10BWG	1 SA	T					
3	2	E5-1c		72 X 90	X		INSTALL	ON EXISTING MOUNT				45.0		
5	1	D3-1G		66 X 12	X		INSTALL ON EXISTING	BRIDGE MOUNT		N		5.5		

ALUMINUM SIGN BLANKS THICKNESS	
Square Feet	Minimum Thickness
Less than 7.5	0.080"
7.5 to 15	0.100"
Greater than 15	0.125"

The Standard Highway Sign Designs for Texas (SHSD) can be found at the following website.
<http://www.txdot.gov/>

- NOTE:**
- Sign supports shall be located as shown on the plans, except that the Engineer may shift the sign supports, within design guidelines, where necessary to secure a more desirable location or to avoid conflict with utilities. Unless otherwise shown on the plans, the Contractor shall stake and the Engineer will verify all sign support locations.
 - For installation of bridge mount clearance signs, see Bridge Mounted Clearance Sign Assembly (BMCS) Standard Sheet.
 - For Sign Support Descriptive Codes, see Sign Mounting Details Small Roadside Signs General Notes & Details SMD(GEN).

SHEET 1 OF 35













SUMMARY OF SMALL SIGNS

SOSS

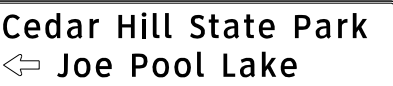
FILE: slums16.dgn	DN: TxDOT	CK: TxDOT	DW: TxDOT	CR: TxDOT
© TxDOT May 1987	CONT	SECT	JOB	HIGHWAY
REVISIONS	0095	14	033, ETC	IH 20
4-16	DIST	COUNTY	SHEET NO.	
8-16	DAL	VARIOUS	43	

SUMMARY OF SMALL SIGNS

DISCLAIMER: The use of this standard is governed by the "Texas Engineering Practice Act". No warranty of any kind is made by TxDOT for any purpose whatsoever. TxDOT assumes no responsibility for the conversion of this standard to other formats or for incorrect results or damages resulting from its use.
 DATE: 3/20/2023 3:23:58 PM
 FILE: T:\DAL\TRAFFIC\2023 PS&E\IH 20 Signing\IH 20 Soss.dgn

PLAN SHEET NO.	SIGN NO.	SIGN NOMENCLATURE	SIGN	DIMENSIONS	FLAT ALUMINUM (TYPE A)	EXAL ALUMINUM (TYPE G)	SM RD SGN ASSM TY XXXXX (X) XX (X-XXXX)				BRIDGE MOUNT CLEARANCE SIGNS (See Note 2)	REPLACE ALUM SIGNS SF		
							POST TYPE	POSTS	ANCHOR TYPE	MOUNTING DESIGNATION		TY = TYPE	TYPE A	TYPE G
							FRP = Fiberglass TWT = Thin-Wall 10BWG = 10 BWG S80 = Sch 80	1 or 2	UA=Universal Conc UB=Universal Bolt SA=Slipbase-Conc SB=Slipbase-Bolt WS=Wedge Steel WP=Wedge Plastic	PREFABRICATED P = "Plain" T = "T" U = "U"				
			IH 20 (CSJ:2374-04-087)											
5	3	D3-1G		66 X 12	X		INSTALL ON EXISTING	BRIDGE MOUNT		N	5.5			
5	5	E5-1c		72 X 90	X		INSTALL ON EXISTING	MOUNT				45.0		
6	1	E5-1c		72 X 90	X		INSTALL ON EXISTING	MOUNT				45.0		
6	3	I-2dT		96 X 24	X		INSTALL ON EXISTING	MOUNT				16.0		
6	4	D1-2		108 X 30	X		S80	1	SA	U	BM			
6	5	D1-2		102 X 24	X		INSTALL ON EXISTING	MOUNT				17.0		
6	7	D1-2		108 X 30	X		S80	1	SA	U	BM			
6	10	D10-3		12 X 48	X		INSTALL ON EXISTING	MOUNT				4.0		
6	11	D10-3		12 X 48	X		INSTALL ON EXISTING	MOUNT				4.0		
7	1	E5-1c		60 X 90	X		INSTALL ON EXISTING	MOUNT				37.5		
7	6	E5-1c		60 X 90	X		INSTALL ON EXISTING	MOUNT				37.5		
8	2	D1-2		168 X 30	X		INSTALL ON EXISTING	MOUNT				35.0		

ALUMINUM SIGN BLANKS THICKNESS	
Square Feet	Minimum Thickness
Less than 7.5	0.080"
7.5 to 15	0.100"
Greater than 15	0.125"

The Standard Highway Sign Designs for Texas (SHSD) can be found at the following website.
<http://www.txdot.gov/>

- NOTE:**
- Sign supports shall be located as shown on the plans, except that the Engineer may shift the sign supports, within design guidelines, where necessary to secure a more desirable location or to avoid conflict with utilities. Unless otherwise shown on the plans, the Contractor shall stake and the Engineer will verify all sign support locations.
 - For installation of bridge mount clearance signs, see Bridge Mounted Clearance Sign Assembly (BMCS) Standard Sheet.
 - For Sign Support Descriptive Codes, see Sign Mounting Details Small Roadside Signs General Notes & Details SMD(GEN).

SHEET 2 OF 35



SUMMARY OF SMALL SIGNS

SOSS

FILE: slums16.dgn	DN: TxDOT	CK: TxDOT	DW: TxDOT	CR: TxDOT
© TxDOT May 1987	CONT	SECT	JOB	HIGHWAY
REVISIONS	0095	14	033, ETC	IH 20
4-16	DIST	COUNTY	SHEET NO.	
8-16	DAL	VARIOUS	44	

SUMMARY OF SMALL SIGNS

PLAN SHEET NO.	SIGN NO.	SIGN NOMENCLATURE	SIGN	DIMENSIONS	FLAT ALUMINUM (TYPE A)	EXAL ALUMINUM (TYPE G)	SM RD SGN ASSM TY XXXXX (X) XX (X-XXXX)				BRIDGE MOUNT CLEARANCE SIGNS (See Note 2)	REPLACE ALUM SIGNS SF		
							POST TYPE	POSTS	ANCHOR TYPE	MOUNTING DESIGNATION		TY = TYPE	TYPE A	TYPE G
			IH 20 (CSJ:2374-04-087)											
8	4	E5-1c		60 X 90	X		INSTALL	ON EXISTING MOUNT					37.5	
8	5	D10-3		12 X 48	X		INSTALL	ON EXISTING MOUNT					4.0	
8	8	D1-2		168 X 30	X		INSTALL	ON EXISTING MOUNT					35.0	
8	10	D10-3		12 X 48	X		INSTALL	ON EXISTING MOUNT					4.0	
10	1	D10-3		12 X 48	X		INSTALL	ON EXISTING MOUNT					4.0	
10	2	D10-3		12 X 48	X		INSTALL	ON EXISTING MOUNT					4.0	
10	4	E5-1c		60 X 90	X		INSTALL	ON EXISTING MOUNT					37.5	
11	2	E5-1c		60 X 90	X		INSTALL	ON EXISTING MOUNT					37.5	
12	2	D10-3		12 X 48	X		INSTALL	ON EXISTING MOUNT					4.0	
12	5	D10-3		12 X 48	X		INSTALL	ON EXISTING MOUNT					4.0	
12	6	E5-1c		60 X 90	X		INSTALL	ON EXISTING MOUNT					37.5	
13	2	D3-1G		66 X 12	X		INSTALL ON EXISTING	BRIDGE MOUNT		N			5.5	

DISCLAIMER: The use of this standard is governed by the "Texas Engineering Practice Act". No warranty of any kind is made by TxDOT for any purpose whatsoever. TxDOT assumes no responsibility for the conversion of this standard to other formats or for incorrect results or damages resulting from its use.

ALUMINUM SIGN BLANKS THICKNESS	
Square Feet	Minimum Thickness
Less than 7.5	0.080"
7.5 to 15	0.100"
Greater than 15	0.125"

The Standard Highway Sign Designs for Texas (SHSD) can be found at the following website.
<http://www.txdot.gov/>

- NOTE:**
- Sign supports shall be located as shown on the plans, except that the Engineer may shift the sign supports, within design guidelines, where necessary to secure a more desirable location or to avoid conflict with utilities. Unless otherwise shown on the plans, the Contractor shall stake and the Engineer will verify all sign support locations.
 - For installation of bridge mount clearance signs, see Bridge Mounted Clearance Sign Assembly (BMCS) Standard Sheet.
 - For Sign Support Descriptive Codes, see Sign Mounting Details Small Roadside Signs General Notes & Details SMD(GEN).

SHEET 3 OF 35



SUMMARY OF SMALL SIGNS

SOSS

FILE: slums16.dgn	DN: TxDOT	CK: TxDOT	DW: TxDOT	CR: TxDOT
© TxDOT May 1987	CONT	SECT	JOB	HIGHWAY
REVISIONS	0095	14	033, ETC	IH 20
4-16	DIST	COUNTY	SHEET NO.	
8-16	DAL	VARIOUS	45	

SUMMARY OF SMALL SIGNS

DISCLAIMER: The use of this standard is governed by the "Texas Engineering Practice Act". No warranty of any kind is made by TxDOT for any purpose whatsoever. TxDOT assumes no responsibility for the conversion of this standard to other formats or for incorrect results or damages resulting from its use.
 DATE: 3/20/2023 3:24:01 PM
 FILE: T:\DAL\TRAFM\FY 2023 PS&E\IH 20\Signing\IH 20_SOSS.dgn

PLAN SHEET NO.	SIGN NO.	SIGN NOMENCLATURE	SIGN	DIMENSIONS	FLAT ALUMINUM (TYPE A)	EXAL ALUMINUM (TYPE G)	SM RD SGN ASSM TY XXXXX (X) XX (X-XXXX)				BRIDGE MOUNT CLEARANCE SIGNS (See Note 2)	REPLACE ALUM SIGNS SF		
							POST TYPE	POSTS	ANCHOR TYPE	MOUNTING DESIGNATION		TY = TYPE	TYPE A	TYPE G
							FRP = Fiberglass TWT = Thin-Wall 10BWG = 10 BWG S80 = Sch 80	1 or 2	UA=Universal Conc UB=Universal Bolt SA=Slipbase-Conc SB=Slipbase-Bolt WS=Wedge Steel WP=Wedge Plastic	PREFABRICATED 1EXT or 2EXT = # of Ext BM = Extruded Wind Beam WC = 1.12 #/ft Wing Channel EXAL= Extruded Alum Sign Panels				
			IH 20 (CSJ:2374-04-087)											
13	3	D1-1	Cedar Ridge Dr	120 X 18	X		INSTALL ON EXISTING MOUNT					15.0		
13	4	D3-1G	Cedar Ridge	66 X 12	X		INSTALL ON EXISTING BRIDGE MOUNT			N		5.5		
13	6	E5-1c		60 X 90	X		INSTALL ON EXISTING MOUNT					37.5		
13	9	I-2aT	Duncanville CITY LIMIT	84 X 24	X		INSTALL ON EXISTING MOUNT					14.0		
14	1	D3-1G	Hill City Dr	60 X 12	X		INSTALL ON EXISTING BRIDGE MOUNT			N		5.0		
14	3	D10-3		12 X 48	X		INSTALL ON EXISTING MOUNT					4.0		
14	4	D10-3		12 X 48	X		INSTALL ON EXISTING MOUNT					4.0		
14	6	D3-1G	Hill City Dr	60 X 12	X		INSTALL ON EXISTING BRIDGE MOUNT			N		5.0		
14	8	E5-1c		60 X 90	X		INSTALL ON EXISTING MOUNT					37.5		
15	1	D3-1G	Duncanville Rd	78 X 12	X		INSTALL ON EXISTING BRIDGE MOUNT			N		6.5		
15	2	D1-1	Duncanville Rd	114 X 18	X		INSTALL ON EXISTING MOUNT					14.25		
15	3	D3-1G	Main St	42 X 12	X		INSTALL ON EXISTING BRIDGE MOUNT			N		3.5		

ALUMINUM SIGN BLANKS THICKNESS	
Square Feet	Minimum Thickness
Less than 7.5	0.080"
7.5 to 15	0.100"
Greater than 15	0.125"

The Standard Highway Sign Designs for Texas (SHSD) can be found at the following website.
<http://www.txdot.gov/>

- NOTE:**
- Sign supports shall be located as shown on the plans, except that the Engineer may shift the sign supports, within design guidelines, where necessary to secure a more desirable location or to avoid conflict with utilities. Unless otherwise shown on the plans, the Contractor shall stake and the Engineer will verify all sign support locations.
 - For installation of bridge mount clearance signs, see Bridge Mounted Clearance Sign Assembly (BMCS) Standard Sheet.
 - For Sign Support Descriptive Codes, see Sign Mounting Details Small Roadside Signs General Notes & Details SMD(GEN).

SHEET 4 OF 35



SUMMARY OF SMALL SIGNS

SOSS

FILE: slums16.dgn	DN: TxDOT	CK: TxDOT	DW: TxDOT	CR: TxDOT
© TxDOT May 1987	CONT	SECT	JOB	HIGHWAY
REVISIONS	0095	14	033, ETC	IH 20
4-16	DIST	COUNTY	SHEET NO.	
8-16	DAL	VARIOUS	46	

SUMMARY OF SMALL SIGNS

DATE: 3/20/2023 3:24:03 PM
 FILE: T:\DAL\TRAFM\FY 2023 PS&E\IH 20\Signing\IH 20_SOSS.dgn
 DISCLAIMER: The use of this standard is governed by the "Texas Engineering Practice Act". No warranty of any kind is made by TxDOT for any purpose whatsoever. TxDOT assumes no responsibility for the conversion of this standard to other formats or for incorrect results or damages resulting from its use.

PLAN SHEET NO.	SIGN NO.	SIGN NOMENCLATURE	SIGN	DIMENSIONS	FLAT ALUMINUM (TYPE A)	EXAL ALUMINUM (TYPE G)	SM RD SGN ASSM TY XXXXX (X) XX (X-XXXX)				BRIDGE MOUNT CLEARANCE SIGNS (See Note 2)	REPLACE ALUM SIGNS SF		
							POST TYPE	POSTS	ANCHOR TYPE	MOUNTING DESIGNATION		TY = TYPE	TYPE A	TYPE G
							FRP = Fiberglass TWT = Thin-Wall 10BWG = 10 BWG S80 = Sch 80	1 or 2	UA=Universal Conc UB=Universal Bolt SA=Slipbase-Conc SB=Slipbase-Bolt WS=Wedge Steel WP=Wedge Plastic	PREFABRICATED P = "Plain" T = "T" U = "U"				
			IH 20 (CSJ:2374-04-087)											
15	5	E5-1c		60 X 90		X		INSTALL	ON EXISTING MOUNT				37.5	
15	6	D1-1		84 X 18		X		INSTALL	ON EXISTING MOUNT				10.5	
15	7	D3-1G		78 X 12		X		INSTALL ON EXISTING	BRIDGE MOUNT	N			6.5	
15	8	D3-1G		42 X 12		X		INSTALL ON EXISTING	BRIDGE MOUNT	N			3.5	
16	1	D3-1G		60 X 12		X		INSTALL ON EXISTING	BRIDGE MOUNT	N			5.0	
16	2	D3-1G		60 X 12		X		INSTALL ON EXISTING	BRIDGE MOUNT	N			5.0	
16	4	D10-3		12 X 48		X		INSTALL	ON EXISTING MOUNT				4.0	
17	1	I-2aT		84 X 24		X		INSTALL	ON EXISTING MOUNT				14.0	
17	3	D1-1		132 X 18		X		INSTALL	ON EXISTING MOUNT				16.5	
18	1	D10-3		12 X 48		X		INSTALL	ON EXISTING MOUNT				4.0	
18	2	D10-3		12 X 48		X		INSTALL	ON EXISTING MOUNT				4.0	

ALUMINUM SIGN BLANKS THICKNESS	
Square Feet	Minimum Thickness
Less than 7.5	0.080"
7.5 to 15	0.100"
Greater than 15	0.125"

The Standard Highway Sign Designs for Texas (SHSD) can be found at the following website.
<http://www.txdot.gov/>

- NOTE:**
- Sign supports shall be located as shown on the plans, except that the Engineer may shift the sign supports, within design guidelines, where necessary to secure a more desirable location or to avoid conflict with utilities. Unless otherwise shown on the plans, the Contractor shall stake and the Engineer will verify all sign support locations.
 - For installation of bridge mount clearance signs, see Bridge Mounted Clearance Sign Assembly (BMCS) Standard Sheet.
 - For Sign Support Descriptive Codes, see Sign Mounting Details Small Roadside Signs General Notes & Details SMD(GEN).

SHEET 5 OF 35











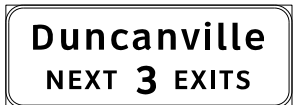
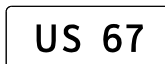

SUMMARY OF SMALL SIGNS

SOSS

FILE: slums16.dgn	DN: TxDOT	CK: TxDOT	DW: TxDOT	CK: TxDOT
© TxDOT May 1987	CONT	SECT	JOB	HIGHWAY
4-16 8-16	REVISIONS	0095 14	033, ETC	IH 20
	DIST	COUNTY	SHEET NO.	
	DAL	VARIOUS	47	

SUMMARY OF SMALL SIGNS

DATE: 3/20/2023 3:24:05 PM
 FILE: T:\DAL\TRAFFIC\2023 PS&E\IH 20\Signing\IH 20_SOSS.dgn
 DISCLAIMER: The use of this standard is governed by the "Texas Engineering Practice Act". No warranty of any kind is made by TxDOT for any purpose whatsoever. TxDOT assumes no responsibility for the conversion of this standard to other formats or for incorrect results or damages resulting from its use.

PLAN SHEET NO.	SIGN NO.	SIGN NOMENCLATURE	SIGN	DIMENSIONS	FLAT ALUMINUM (TYPE A)	EXAL ALUMINUM (TYPE G)	SM RD SGN ASSM TY XXXXX (X) XX (X-XXXX)				BRIDGE MOUNT CLEARANCE SIGNS (See Note 2)	REPLACE ALUM SIGNS SF		
							POST TYPE	POSTS	ANCHOR TYPE	MOUNTING DESIGNATION		TY = TYPE	TYPE A	TYPE G
							FRP = Fiberglass TWT = Thin-Wall 10BWG = 10 BWG S80 = Sch 80	1 or 2	UA=Universal Conc UB=Universal Bolt SA=Slipbase-Conc SB=Slipbase-Bolt WS=Wedge Steel WP=Wedge Plastic	PREFABRICATED 1EXT or 2EXT = # of Ext BM = Extruded Wind Beam WC = 1.12 #/ft Wing Channel EXAL= Extruded Alum Sign Panels		TY N TY S		
			IH 20 (CSJ:2374-04-087)											
18	3	GREEN		150 X 60	X		S80	2	SA	P	EXAL			
18	4	D3-1G		36 X 12	X		INSTALL ON EXISTING		BRIDGE MOUNT			N	3.0	
18	5	E5-1c		72 X 90	X		INSTALL ON EXISTING		MOUNT				45.0	
18	7	E5-1c		72 X 90	X		INSTALL ON EXISTING		MOUNT				45.0	
18	9	D3-1G		36 X 12	X		INSTALL ON EXISTING		BRIDGE MOUNT			N	3.0	
19	1	E5-1c		72 X 90	X		INSTALL ON EXISTING		MOUNT				45.0	
19	4	E5-1c		72 X 90	X		INSTALL ON EXISTING		MOUNT				45.0	
20	1	D10-3		12 X 48	X		INSTALL ON EXISTING		MOUNT				4.0	
20	3	D1-1		96 X 18	X		INSTALL ON EXISTING		MOUNT				12.0	
21	1	D1-1		108 X 18	X		INSTALL ON EXISTING		MOUNT				13.5	
21	5	E5-1c		60 X 90	X		INSTALL ON EXISTING		MOUNT				37.5	

ALUMINUM SIGN BLANKS THICKNESS	
Square Feet	Minimum Thickness
Less than 7.5	0.080"
7.5 to 15	0.100"
Greater than 15	0.125"

The Standard Highway Sign Designs for Texas (SHSD) can be found at the following website.
<http://www.txdot.gov/>

- NOTE:**
- Sign supports shall be located as shown on the plans, except that the Engineer may shift the sign supports, within design guidelines, where necessary to secure a more desirable location or to avoid conflict with utilities. Unless otherwise shown on the plans, the Contractor shall stake and the Engineer will verify all sign support locations.
 - For installation of bridge mount clearance signs, see Bridge Mounted Clearance Sign Assembly (BMCS) Standard Sheet.
 - For Sign Support Descriptive Codes, see Sign Mounting Details Small Roadside Signs General Notes & Details SMD(GEN).

SHEET 6 OF 35



SUMMARY OF SMALL SIGNS

SOSS

FILE: slums16.dgn	DN: TxDOT	CK: TxDOT	DW: TxDOT	CR: TxDOT
© TxDOT May 1987	CONT	SECT	JOB	HIGHWAY
REVISIONS	0095	14	033, ETC	IH 20
4-16	DIST	COUNTY	SHEET NO.	
8-16	DAL	VARIOUS	48	

SUMMARY OF SMALL SIGNS

DISCLAIMER: The use of this standard is governed by the "Texas Engineering Practice Act". No warranty of any kind is made by TxDOT for any purpose whatsoever. TxDOT assumes no responsibility for the conversion of this standard to other formats or for incorrect results or damages resulting from its use.
 DATE: 3/20/2023 3:24:07 PM
 FILE: T:\DAL\TRAFFIC\2023 PS&E\IH 20\Signing\IH 20 SOSS.dgn

PLAN SHEET NO.	SIGN NO.	SIGN NOMENCLATURE	SIGN	DIMENSIONS	FLAT ALUMINUM (TYPE A)	EXAL ALUMINUM (TYPE G)	SM RD SGN ASSM TY XXXXX (X) XX (X-XXXX)				BRIDGE MOUNT CLEARANCE SIGNS (See Note 2)	REPLACE ALUM SIGNS SF		
							POST TYPE	POSTS	ANCHOR TYPE	MOUNTING DESIGNATION		TY = TYPE	TYPE A	TYPE G
							FRP = Fiberglass TWT = Thin-Wall 10BWG = 10 BWG S80 = Sch 80	1 or 2	UA=Universal Conc UB=Universal Bolt SA=Slipbase-Conc SB=Slipbase-Bolt WS=Wedge Steel WP=Wedge Plastic	PREFABRICATED P = "Plain" T = "T" U = "U"				
			IH 20 (CSJ: 2374-04-087)											
22	1	E5-1c		60 X 90		X	INSTALL	ON EXISTING MOUNT				37.5		
22	2	D10-3		12 X 48		X	INSTALL	ON EXISTING MOUNT				4.0		
22	3	D10-3		12 X 48		X	INSTALL	ON EXISTING MOUNT				4.0		
23	1	D3-1G		42 X 12		X	INSTALL	ON EXISTING BRIDGE MOUNT		N		3.5		
23	4	E5-1c		60 X 90		X	INSTALL	ON EXISTING MOUNT				37.5		
23	5	D10-3		12 X 48		X	INSTALL	ON EXISTING MOUNT				4.0		
23	6	D10-3		12 X 48		X	INSTALL	ON EXISTING MOUNT				4.0		
23	3	GREEN		42 X 12		X	INSTALL	ON EXISTING BRIDGE MOUNT		N		3.5		
24	5	E5-1c		72 X 90		X	INSTALL	ON EXISTING MOUNT				45.0		
25	1	E5-1c		72 X 90		X	INSTALL	ON EXISTING MOUNT				45.0		
			END CSJ: 2374-04-087 BEGIN CSJ: 2374-03-092											
25	2	E5-1c		72 X 90		X	INSTALL	ON EXISTING MOUNT				45.0		

ALUMINUM SIGN BLANKS THICKNESS	
Square Feet	Minimum Thickness
Less than 7.5	0.080"
7.5 to 15	0.100"
Greater than 15	0.125"

The Standard Highway Sign Designs for Texas (SHSD) can be found at the following website.
<http://www.txdot.gov/>

- NOTE:**
- Sign supports shall be located as shown on the plans, except that the Engineer may shift the sign supports, within design guidelines, where necessary to secure a more desirable location or to avoid conflict with utilities. Unless otherwise shown on the plans, the Contractor shall stake and the Engineer will verify all sign support locations.
 - For installation of bridge mount clearance signs, see Bridge Mounted Clearance Sign Assembly (BMCS) Standard Sheet.
 - For Sign Support Descriptive Codes, see Sign Mounting Details Small Roadside Signs General Notes & Details SMD(GEN).

SHEET 7 OF 35



SUMMARY OF SMALL SIGNS

SOSS

FILE: slums16.dgn	DN: TxDOT	CK: TxDOT	DW: TxDOT	CR: TxDOT
© TxDOT May 1987	CONT	SECT	JOB	HIGHWAY
REVISIONS	0095	14	033, ETC	IH 20
4-16	DIST	COUNTY	SHEET NO.	
8-16	DAL	VARIOUS	49	

SUMMARY OF SMALL SIGNS

DISCLAIMER: The use of this standard is governed by the "Texas Engineering Practice Act". No warranty of any kind is made by TxDOT for any purpose whatsoever. TxDOT assumes no responsibility for the conversion of this standard to other formats or for incorrect results or damages resulting from its use.

PLAN SHEET NO.	SIGN NO.	SIGN NOMENCLATURE	SIGN	DIMENSIONS	FLAT ALUMINUM (TYPE A)	EXAL ALUMINUM (TYPE G)	SM RD SGN ASSM TY XXXXX (X) XX (X-XXXX)				BRIDGE MOUNT CLEARANCE SIGNS (See Note 2)	REPLACE ALUM SIGNS SF		
							POST TYPE	POSTS	ANCHOR TYPE	MOUNTING DESIGNATION		TY = TYPE	TYPE A	TYPE G
							FRP = Fiberglass TWT = Thin-Wall 10BWG = 10 BWG S80 = Sch 80	1 or 2	UA=Universal Conc UB=Universal Bolt SA=Slipbase-Conc SB=Slipbase-Bolt WS=Wedge Steel WP=Wedge Plastic	PREFABRICATED P = "Plain" T = "T" U = "U"				
			IH 20 (CSJ:2374-03-092)											
25	5	D10-3	MILE 468	12 X 48	X		INSTALL	ON EXISTING MOUNT				4.00		
25	6	D10-3	MILE 468	12 X 48	X		INSTALL	ON EXISTING MOUNT				4.0		
25	7	E5-1c	EXIT 467B 	72 X 90	X		INSTALL	ON EXISTING MOUNT				45.0		
26	3	I-2aT	Dallas CITY LIMIT	48 X 24	X		INSTALL	ON EXISTING MOUNT				8.0		
26	4	GREEN	UNT Dallas EXIT 468	138 X 54	X	S80	2	SA	P	EXAL				
26	5	I-2aT	Lancaster CITY LIMIT	72 X 24	X		INSTALL	ON EXISTING MOUNT				12.0		
26	6	E5-1c	EXIT 468 	60 X 90	X		INSTALL	ON EXISTING MOUNT				37.5		
27	3	D26-2TL	Texas Dept of Public Safety Driver License	84 X 36	X		INSTALL	ON EXISTING MOUNT				21.0		
27	4	D1-1	UNT Dallas	96 X 18	X	10BWG	1	SA	T					
27	5	D1-2 (MOD)	University Hills Blvd	102 X 30	X		INSTALL	ON EXISTING MOUNT				21.25		
27	6	D10-3	MILE 469	12 X 48	X		INSTALL	ON EXISTING MOUNT				4.0		

ALUMINUM SIGN BLANKS THICKNESS	
Square Feet	Minimum Thickness
Less than 7.5	0.080"
7.5 to 15	0.100"
Greater than 15	0.125"

The Standard Highway Sign Designs for Texas (SHSD) can be found at the following website.
<http://www.txdot.gov/>

- NOTE:**
- Sign supports shall be located as shown on the plans, except that the Engineer may shift the sign supports, within design guidelines, where necessary to secure a more desirable location or to avoid conflict with utilities. Unless otherwise shown on the plans, the Contractor shall stake and the Engineer will verify all sign support locations.
 - For installation of bridge mount clearance signs, see Bridge Mounted Clearance Sign Assembly (BMCS) Standard Sheet.
 - For Sign Support Descriptive Codes, see Sign Mounting Details Small Roadside Signs General Notes & Details SMD(GEN).

SHEET 8 OF 35















SUMMARY OF SMALL SIGNS

SOSS

FILE: slms16.dgn	DN: TxDOT	CK: TxDOT	DW: TxDOT	CR: TxDOT
© TxDOT May 1987	CONT	SECT	JOB	HIGHWAY
REVISIONS	0095	14	033, ETC	IH 20
4-16	DIST	COUNTY	SHEET NO.	
8-16	DAL	VARIOUS	50	

SUMMARY OF SMALL SIGNS

DISCLAIMER: The use of this standard is governed by the "Texas Engineering Practice Act". No warranty of any kind is made by TxDOT for any purpose whatsoever. TxDOT assumes no responsibility for the conversion of this standard to other formats or for incorrect results or damages resulting from its use.
 DATE: 3/20/2023 3:24:11 PM
 FILE: T:\DAL\TRAFFIC\2023 PS&E\IH 20\Signing\IH 20_SOSS.dgn

PLAN SHEET NO.	SIGN NO.	SIGN NOMENCLATURE	SIGN	DIMENSIONS	FLAT ALUMINUM (TYPE A)	EXAL ALUMINUM (TYPE G)	SM RD SGN ASSM TY XXXXX (X) XX (X-XXXX)				BRIDGE MOUNT CLEARANCE SIGNS (See Note 2)	REPLACE ALUM SIGNS SF		
							POST TYPE	POSTS	ANCHOR TYPE	MOUNTING DESIGNATION		TY = TYPE	TYPE A	TYPE G
							FRP = Fiberglass TWT = Thin-Wall 10BWG = 10 BWG S80 = Sch 80	1 or 2	UA=Universal Conc UB=Universal Bolt SA=Slipbase-Conc SB=Slipbase-Bolt WS=Wedge Steel WP=Wedge Plastic	PREFABRICATED P = "Plain" T = "T" U = "U"				
			IH 20 (CSJ:2374-03-092)											
27	7	D10-3		12 X 48	X		INSTALL	ON EXISTING MOUNT				4.0		
27	8	E5-1c		60 X 90	X		INSTALL	ON EXISTING MOUNT				37.5		
27	9	D1-2 (MOD)		102 X 30	X		S80	1	SA	U	BM			
27	10	D1-1		96 X 18	X		10BWG	1	SA	T				
27	11	R5-1		48 X 48	X		10BWG	1	SA	T				
28	2	E5-1c		60 X 90	X		INSTALL	ON EXISTING MOUNT				37.5		
29	2	I-2aT		72 X 24	X		INSTALL	ON EXISTING MOUNT				12.0		
29	3	GREEN		138 X 54	X		S80	2	SA	P	EXAL			
29	4	D10-3		12 X 48	X		INSTALL	ON EXISTING MOUNT				4.0		
29	5	D10-3		12 X 48	X		INSTALL	ON EXISTING MOUNT				4.0		
29	6	I-2aT		48 X 24	X		INSTALL	ON EXISTING MOUNT				8.0		
29	7	D1-2		90 X 30	X		INSTALL	ON EXISTING MOUNT				18.75		

ALUMINUM SIGN BLANKS THICKNESS	
Square Feet	Minimum Thickness
Less than 7.5	0.080"
7.5 to 15	0.100"
Greater than 15	0.125"

The Standard Highway Sign Designs for Texas (SHSD) can be found at the following website.
<http://www.txdot.gov/>

- NOTE:**
- Sign supports shall be located as shown on the plans, except that the Engineer may shift the sign supports, within design guidelines, where necessary to secure a more desirable location or to avoid conflict with utilities. Unless otherwise shown on the plans, the Contractor shall stake and the Engineer will verify all sign support locations.
 - For installation of bridge mount clearance signs, see Bridge Mounted Clearance Sign Assembly (BMCS) Standard Sheet.
 - For Sign Support Descriptive Codes, see Sign Mounting Details Small Roadside Signs General Notes & Details SMD(GEN).

SHEET 9 OF 35



SUMMARY OF SMALL SIGNS

SOSS

FILE: slums16.dgn	DN: TxDOT	CK: TxDOT	DW: TxDOT	CR: TxDOT
© TxDOT May 1987	CONT	SECT	JOB	HIGHWAY
REVISIONS	0095	14	033, ETC	IH 20
4-16	DIST	COUNTY	SHEET NO.	
8-16	DAL	VARIOUS	51	

SUMMARY OF SMALL SIGNS

DATE: 3/20/2023 3:24:12 PM
 FILE: T:\DAL\TRAFM\FY 2023 PS&E\IH 20 Signing\IH 20 Soss.dgn
 DISCLAIMER: The use of this standard is governed by the "Texas Engineering Practice Act". No warranty of any kind is made by TxDOT for any purpose whatsoever. TxDOT assumes no responsibility for the conversion of this standard to other formats or for incorrect results or damages resulting from its use.

PLAN SHEET NO.	SIGN NO.	SIGN NOMENCLATURE	SIGN	DIMENSIONS	FLAT ALUMINUM (TYPE A)	EXAL ALUMINUM (TYPE G)	SM RD SGN ASSM TY XXXXX (X) XX (X-XXXX)				BRIDGE MOUNT CLEARANCE SIGNS (See Note 2)	REPLACE ALUM SIGNS SF		
							POST TYPE	POSTS	ANCHOR TYPE	MOUNTING DESIGNATION		TY = TYPE	TYPE A	TYPE G
							FRP = Fiberglass TWT = Thin-Wall 10BWG = 10 BWG S80 = Sch 80	1 or 2	UA=Universal Conc UB=Universal Bolt SA=Slipbase-Conc SB=Slipbase-Bolt WS=Wedge Steel WP=Wedge Plastic	PREFABRICATED 1EXT or 2EXT = # of Ext BM = Extruded Wind Beam WC = 1.12 #/ft Wing Channel EXAL= Extruded Alum Sign Panels		TY N TY S		
			IH 20 (CSJ:2374-03-092)											
29	8	I-12 GREEN M6-1		30 x 38 21 x 15	X				INSTALL ON EXISTING MOUNT			7.92 2.19		
29	9	D25-2TL		48 x 48	X				INSTALL ON EXISTING MOUNT			16.0		
30	1	D25-2TR		48 x 48	X				INSTALL ON EXISTING MOUNT			16.0		
30	2	D1-2		90 x 30	X				INSTALL ON EXISTING MOUNT			18.75		
30	3	I-12 GREEN M6-1		30 x 38 21 x 15	X				INSTALL ON EXISTING MOUNT			7.92 2.19		
30	6	E5-1c		60 x 90	X				INSTALL ON EXISTING MOUNT			37.5		
31	1	D10-3		12 x 48	X				INSTALL ON EXISTING MOUNT			4.0		
31	2	D10-3		12 x 48	X				INSTALL ON EXISTING MOUNT			4.0		
32	4	E5-1c		60 x 90	X				INSTALL ON EXISTING MOUNT			37.5		

ALUMINUM SIGN BLANKS THICKNESS	
Square Feet	Minimum Thickness
Less than 7.5	0.080"
7.5 to 15	0.100"
Greater than 15	0.125"

The Standard Highway Sign Designs for Texas (SHSD) can be found at the following website.
<http://www.txdot.gov/>

- NOTE:**
- Sign supports shall be located as shown on the plans, except that the Engineer may shift the sign supports, within design guidelines, where necessary to secure a more desirable location or to avoid conflict with utilities. Unless otherwise shown on the plans, the Contractor shall stake and the Engineer will verify all sign support locations.
 - For installation of bridge mount clearance signs, see Bridge Mounted Clearance Sign Assembly (BMCS) Standard Sheet.
 - For Sign Support Descriptive Codes, see Sign Mounting Details Small Roadside Signs General Notes & Details SMD(GEN).

SHEET 10 OF 35













SUMMARY OF SMALL SIGNS

SOSS

FILE: slums16.dgn	DN: TxDOT	CK: TxDOT	DW: TxDOT	CR: TxDOT
© TxDOT May 1987	CONT	SECT	JOB	HIGHWAY
REVISIONS	0095	14	033, ETC	IH 20
4-16	DIST	COUNTY	SHEET NO.	
8-16	DAL	VARIOUS	52	

SUMMARY OF SMALL SIGNS

DISCLAIMER: The use of this standard is governed by the "Texas Engineering Practice Act". No warranty of any kind is made by TxDOT for any purpose whatsoever. TxDOT assumes no responsibility for the conversion of this standard to other formats or for incorrect results or damages resulting from its use.
 DATE: 3/20/2023 3:24:15 PM
 FILE: T:\DAL\TRAFFIC\2023 PS&E\IH 20 Signing\IH 20 Soss.dgn

PLAN SHEET NO.	SIGN NO.	SIGN NOMENCLATURE	SIGN	DIMENSIONS	FLAT ALUMINUM (TYPE A)	EXAL ALUMINUM (TYPE G)	SM RD SGN ASSM TY XXXXX (X) XX (X-XXXX)				BRIDGE MOUNT CLEARANCE SIGNS (See Note 2)	REPLACE ALUM SIGNS SF		
							POST TYPE	POSTS	ANCHOR TYPE	MOUNTING DESIGNATION		TY = TYPE	TYPE A	TYPE G
							FRP = Fiberglass TWT = Thin-Wall 10BWG = 10 BWG S80 = Sch 80	1 or 2	UA=Universal Conc UB=Universal Bolt SA=Slipbase-Conc SB=Slipbase-Bolt WS=Wedge Steel WP=Wedge Plastic	PREFABRICATED P = "Plain" T = "T" U = "U"				
			IH 20 (CSJ:2374-03-092)											
33	1	D10-3		12 X 48	X		INSTALL	ON EXISTING MOUNT				4.0		
33	2	D10-3		12 X 48	X		INSTALL	ON EXISTING MOUNT				4.0		
33	3	D3-1G	Bonnie View Rd	78 X 12	X		INSTALL ON EXISTING	BRIDGE MOUNT		N		6.5		
33	4	E5-1c		60 X 90	X		INSTALL	ON EXISTING MOUNT				37.5		
33	5	GREEN	Bonnie View Rd	78 X 12	X		INSTALL ON EXISTING	BRIDGE MOUNT		N		6.5		
35	1	D10-3		12 X 48	X		INSTALL	ON EXISTING MOUNT				4.0		
35	2	D10-3		12 X 48	X		INSTALL	ON EXISTING MOUNT				4.0		
35	4	E5-1c		72 X 90	X		INSTALL	ON EXISTING MOUNT				45.0		
35	8	E5-1c		72 X 90	X		INSTALL	ON EXISTING MOUNT				45.0		
36	1	E5-1c		72 X 90	X		INSTALL	ON EXISTING MOUNT				45.0		
36	3	D1-2		78 X 30	X		INSTALL	ON EXISTING MOUNT				16.25		
36	4	E5-1c		72 X 90	X		INSTALL	ON EXISTING MOUNT				45.0		

ALUMINUM SIGN BLANKS THICKNESS	
Square Feet	Minimum Thickness
Less than 7.5	0.080"
7.5 to 15	0.100"
Greater than 15	0.125"

The Standard Highway Sign Designs for Texas (SHSD) can be found at the following website.
<http://www.txdot.gov/>

- NOTE:**
- Sign supports shall be located as shown on the plans, except that the Engineer may shift the sign supports, within design guidelines, where necessary to secure a more desirable location or to avoid conflict with utilities. Unless otherwise shown on the plans, the Contractor shall stake and the Engineer will verify all sign support locations.
 - For installation of bridge mount clearance signs, see Bridge Mounted Clearance Sign Assembly (BMCS) Standard Sheet.
 - For Sign Support Descriptive Codes, see Sign Mounting Details Small Roadside Signs General Notes & Details SMD(GEN).

SHEET 11 OF 35















SUMMARY OF SMALL SIGNS

SOSS

FILE: slums16.dgn	DN: TxDOT	CK: TxDOT	DW: TxDOT	CR: TxDOT
© TxDOT May 1987	CONT	SECT	JOB	HIGHWAY
REVISIONS	0095	14	033, ETC	IH 20
4-16	DIST	COUNTY	SHEET NO.	
8-16	DAL	VARIOUS	53	

SUMMARY OF SMALL SIGNS

DISCLAIMER: The use of this standard is governed by the "Texas Engineering Practice Act". No warranty of any kind is made by TxDOT for any purpose whatsoever. TxDOT assumes no responsibility for the conversion of this standard to other formats or for incorrect results or damages resulting from its use.
 DATE: 3/20/2023 3:24:17 PM
 FILE: I:\DAL\TRAFM\FY 2023 PS&E\IH 20\Signing\IH 20_SOSS.dgn

PLAN SHEET NO.	SIGN NO.	SIGN NOMENCLATURE	SIGN	DIMENSIONS	FLAT ALUMINUM (TYPE A)	EXAL ALUMINUM (TYPE G)	SM RD SGN ASSM TY XXXXX (X) XX (X-XXXX)				BRIDGE MOUNT CLEARANCE SIGNS (See Note 2)	REPLACE ALUM SIGNS SF		
							POST TYPE	POSTS	ANCHOR TYPE	MOUNTING DESIGNATION		TY = TYPE	TYPE A	TYPE G
							FRP = Fiberglass TWT = Thin-Wall 10BWG = 10 BWG S80 = Sch 80	1 or 2	UA=Universal Conc UB=Universal Bolt SA=Slipbase-Conc SB=Slipbase-Bolt WS=Wedge Steel WP=Wedge Plastic	PREFABRICATED P = "Plain" T = "T" U = "U"				
			IH 20 (CSJ:2374-03-092)											
36	9	E5-1c		72 X 90		X	INSTALL	ON EXISTING MOUNT				45.0		
37	1	I-2aT		48 X 24		X	INSTALL	ON EXISTING MOUNT				8.0		
37	2	E5-1c		60 X 90		X	INSTALL	ON EXISTING MOUNT				37.5		
37	3	I-2aT		66 X 24		X	INSTALL	ON EXISTING MOUNT				11.0		
37	4	D10-3		12 X 48		X	INSTALL	ON EXISTING MOUNT				4.0		
37	5	D10-3		12 X 48		X	INSTALL	ON EXISTING MOUNT				4.0		
39	1	D10-3		12 X 48		X	INSTALL	ON EXISTING MOUNT				4.0		
39	2	D10-3		12 X 48		X	INSTALL	ON EXISTING MOUNT				4.0		
40	1	I-2aT		66 X 24		X	INSTALL	ON EXISTING MOUNT				11.0		
40	2	I-3		54 X 30		X	INSTALL	ON EXISTING MOUNT				11.25		
40	3	I-2aT		48 X 24		X	INSTALL	ON EXISTING MOUNT				8.0		
40	4	I-3		54 X 30		X	INSTALL	ON EXISTING MOUNT				11.25		

ALUMINUM SIGN BLANKS THICKNESS	
Square Feet	Minimum Thickness
Less than 7.5	0.080"
7.5 to 15	0.100"
Greater than 15	0.125"

The Standard Highway Sign Designs for Texas (SHSD) can be found at the following website.
<http://www.txdot.gov/>

- NOTE:**
- Sign supports shall be located as shown on the plans, except that the Engineer may shift the sign supports, within design guidelines, where necessary to secure a more desirable location or to avoid conflict with utilities. Unless otherwise shown on the plans, the Contractor shall stake and the Engineer will verify all sign support locations.
 - For installation of bridge mount clearance signs, see Bridge Mounted Clearance Sign Assembly (BMCS) Standard Sheet.
 - For Sign Support Descriptive Codes, see Sign Mounting Details Small Roadside Signs General Notes & Details SMD(GEN).

SHEET 12 OF 35















SUMMARY OF SMALL SIGNS

SOSS

FILE: slums16.dgn	DN: TxDOT	CK: TxDOT	DW: TxDOT	CR: TxDOT
© TxDOT May 1987	CONT	SECT	JOB	HIGHWAY
REVISIONS	0095	14	033, ETC	IH 20
4-16	DIST	COUNTY	SHEET NO.	
8-16	DAL	VARIOUS	54	

SUMMARY OF SMALL SIGNS

DISCLAIMER: The use of this standard is governed by the "Texas Engineering Practice Act". No warranty of any kind is made by TxDOT for any purpose whatsoever. TxDOT assumes no responsibility for the conversion of this standard to other formats or for incorrect results or damages resulting from its use.
 DATE: 3/20/2023 3:24:18 PM
 FILE: T:\DAL\TRAFFIC\2023 PS&E\IH 20\Signing\IH 20 SOSS.dgn

PLAN SHEET NO.	SIGN NO.	SIGN NOMENCLATURE	SIGN	DIMENSIONS	FLAT ALUMINUM (TYPE A)	EXAL ALUMINUM (TYPE G)	SM RD SGN ASSM TY XXXXX (X) XX (X-XXXX)				BRIDGE MOUNT CLEARANCE SIGNS (See Note 2)	REPLACE ALUM SIGNS SF		
							POST TYPE	POSTS	ANCHOR TYPE	MOUNTING DESIGNATION		TY = TYPE	TYPE A	TYPE G
							FRP = Fiberglass TWT = Thin-Wall 10BWG = 10 BWG S80 = Sch 80	1 or 2	UA=Universal Conc UB=Universal Bolt SA=Slipbase-Conc SB=Slipbase-Bolt WS=Wedge Steel WP=Wedge Plastic	PREFABRICATED 1EXT or 2EXT = # of Ext BM = Extruded Wind Beam WC = 1.12 #/ft Wing Channel EXAL= Extruded Alum Sign Panels		TY N TY S		
			IH 20 (CSJ:2374-03-092)											
40	5	D10-3		12 X 48	X		INSTALL	ON EXISTING MOUNT				4.0		
40	6	D10-3		12 X 48	X		INSTALL	ON EXISTING MOUNT				4.0		
42	3	E5-1c		60 X 90		X	INSTALL	ON EXISTING MOUNT				37.5		
42	5	D10-3		12 X 48	X		INSTALL	ON EXISTING MOUNT				4.0		
42	6	D10-3		12 X 48	X		INSTALL	ON EXISTING MOUNT				4.0		
42	7	E5-1c		60 X 90		X	INSTALL	ON EXISTING MOUNT				37.5		
44	2	D10-3		12 X 48	X		INSTALL	ON EXISTING MOUNT				4.0		
44	3	D10-3		12 X 48	X		INSTALL	ON EXISTING MOUNT				4.0		
44	4	E5-1c		60 X 90		X	INSTALL	ON EXISTING MOUNT				37.5		
46	2	D10-3		12 X 48	X		INSTALL	ON EXISTING MOUNT				4.0		
46	3	D10-3		12 X 48	X		INSTALL	ON EXISTING MOUNT				4.0		
46	5	E5-1c		60 X 90		X	INSTALL	ON EXISTING MOUNT				37.5		

ALUMINUM SIGN BLANKS THICKNESS	
Square Feet	Minimum Thickness
Less than 7.5	0.080"
7.5 to 15	0.100"
Greater than 15	0.125"

The Standard Highway Sign Designs for Texas (SHSD) can be found at the following website.
<http://www.txdot.gov/>

- NOTE:**
- Sign supports shall be located as shown on the plans, except that the Engineer may shift the sign supports, within design guidelines, where necessary to secure a more desirable location or to avoid conflict with utilities. Unless otherwise shown on the plans, the Contractor shall stake and the Engineer will verify all sign support locations.
 - For installation of bridge mount clearance signs, see Bridge Mounted Clearance Sign Assembly (BMCS) Standard Sheet.
 - For Sign Support Descriptive Codes, see Sign Mounting Details Small Roadside Signs General Notes & Details SMD(GEN).

SHEET 13 OF 35







SUMMARY OF SMALL SIGNS

SOSS

FILE: slums16.dgn	DN: TxDOT	CK: TxDOT	DW: TxDOT	CR: TxDOT
© TxDOT May 1987	CONT	SECT	JOB	HIGHWAY
REVISIONS	0095	14	033, ETC	IH 20
4-16	DIST	COUNTY	SHEET NO.	
8-16	DAL	VARIOUS	55	

SUMMARY OF SMALL SIGNS

DATE: 3/20/2023 3:24:20 PM
 FILE: T:\DAL\TRAFM\FY 2023 PS&E\IH 20\Signing\IH 20 S0SS.dgn
 The use of this standard is governed by the "Texas Engineering Practice Act". No warranty of any kind is made by TxDOT for any purpose whatsoever. TxDOT assumes no responsibility for the conversion of this standard to other formats or for incorrect results or damages resulting from its use.

PLAN SHEET NO.	SIGN NO.	SIGN NOMENCLATURE	SIGN	DIMENSIONS	FLAT ALUMINUM (TYPE A)	EXAL ALUMINUM (TYPE G)	SM RD SGN ASSM TY XXXXX (X) XX (X-XXXX)				BRIDGE MOUNT CLEARANCE SIGNS (See Note 2)	REPLACE ALUM SIGNS SF		
							POST TYPE	POSTS	ANCHOR TYPE	MOUNTING DESIGNATION		TY = TYPE	TYPE A	TYPE G
							FRP = Fiberglass TWT = Thin-Wall 10BWG = 10 BWG S80 = Sch 80	1 or 2	UA=Universal Conc UB=Universal Bolt SA=Slipbase-Conc SB=Slipbase-Bolt WS=Wedge Steel WP=Wedge Plastic	PREFABRICATED P = "Plain" T = "T" U = "U"				
			IH 20 (CSJ: 2374-03-092)											
46	6	GREEN	Seagoville SECOND RIGHT	132 X 48	X		S80	2	SA	P	EXAL			
47	2	E5-1c		72 X 90	X		INSTALL	ON EXISTING MOUNT					45.0	
47	3	I-2aT	Dallas CITY LIMIT	48 X 24	X		INSTALL	ON EXISTING MOUNT					8.0	
47	4	E5-1c		72 X 90	X		INSTALL	ON EXISTING MOUNT					45.0	
47	6	E5-1c		72 X 90	X		INSTALL	ON EXISTING MOUNT					45.0	
47	10	I-2aT	Balch Springs CITY LIMIT	96 X 24	X		INSTALL	ON EXISTING MOUNT					16.0	
48	1	E5-1c		72 X 90	X		INSTALL	ON EXISTING MOUNT					45.0	
48	4	D10-3		12 X 48	X		INSTALL	ON EXISTING MOUNT					4.0	
			END OF CSJ: 2374-03-092											
			BEGIN OF CSJ: 0095-13-044											
48	14	D3-1G	IH 635	36 X 12	X		INSTALL ON EXISTING	BRIDGE MOUNT		S		3.0		
49	1	D3-1G	IH 635	36 X 12	X		INSTALL ON EXISTING	BRIDGE MOUNT		S		3.0		

ALUMINUM SIGN BLANKS THICKNESS	
Square Feet	Minimum Thickness
Less than 7.5	0.080"
7.5 to 15	0.100"
Greater than 15	0.125"

The Standard Highway Sign Designs for Texas (SHSD) can be found at the following website.
<http://www.txdot.gov/>

- NOTE:**
- Sign supports shall be located as shown on the plans, except that the Engineer may shift the sign supports, within design guidelines, where necessary to secure a more desirable location or to avoid conflict with utilities. Unless otherwise shown on the plans, the Contractor shall stake and the Engineer will verify all sign support locations.
 - For installation of bridge mount clearance signs, see Bridge Mounted Clearance Sign Assembly (BMCS) Standard Sheet.
 - For Sign Support Descriptive Codes, see Sign Mounting Details Small Roadside Signs General Notes & Details SMD(GEN).

SHEET 14 OF 35



SUMMARY OF SMALL SIGNS

SOSS

FILE: slums16.dgn	DN: TxDOT	CK: TxDOT	DW: TxDOT	CK: TxDOT
© TxDOT May 1987	CONT	SECT	JOB	HIGHWAY
REVISIONS	0095 14	033, ETC	IH 20	
4-16	DIST	COUNTY	SHEET NO.	
8-16	DAL	VARIOUS	56	

SUMMARY OF SMALL SIGNS

DISCLAIMER: The use of this standard is governed by the "Texas Engineering Practice Act". No warranty of any kind is made by TxDOT for any purpose whatsoever. TxDOT assumes no responsibility for the conversion of this standard to other formats or for incorrect results or damages resulting from its use.
 DATE: 3/20/2023 3:24:22 PM
 FILE: T:\DAL\TRAFFIC\2023 PS&E\IH 20\Signing\IH 20_SOSS.dgn

PLAN SHEET NO.	SIGN NO.	SIGN NOMENCLATURE	SIGN	DIMENSIONS	FLAT ALUMINUM (TYPE A)	EXAL ALUMINUM (TYPE G)	SM RD SGN ASSM TY XXXXX (X) XX (X-XXXX)				BRIDGE MOUNT CLEARANCE SIGNS (See Note 2)	REPLACE ALUM SIGNS SF		
							POST TYPE	POSTS	ANCHOR TYPE	MOUNTING DESIGNATION		TY = TYPE	TYPE A	TYPE G
							FRP = Fiberglass TWT = Thin-Wall 10BWG = 10 BWG S80 = Sch 80	1 or 2	UA=Universal Conc UB=Universal Bolt SA=Slipbase-Conc SB=Slipbase-Bolt WS=Wedge Steel WP=Wedge Plastic	PREFABRICATED 1EXT or 2EXT = # of Ext BM = Extruded Wind Beam WC = 1.12 #/ft Wing Channel EXAL= Extruded Alum Sign Panels				
			IH 20 (CSJ:0095-13-044)											
49	3	D3-1G		60 X 12	X		INSTALL ON EXISTING	BRIDGE MOUNT		S	5.0			
49	7	D2-2		84 X 30	X		INSTALL ON EXISTING	MOUNT			17.5			
49	8	E5-1c		72 X 90	X		INSTALL ON EXISTING	MOUNT				45.0		
49	9	D3-1G		60 X 12	X		INSTALL ON EXISTING	BRIDGE MOUNT		S	5.0			
50	2	D10-3		12 X 48	X		INSTALL ON EXISTING	MOUNT			4.0			
50	3	D10-3		12 X 48	X		INSTALL ON EXISTING	MOUNT			4.0			
50	8	E5-1c		60 X 90	X		INSTALL ON EXISTING	MOUNT				37.5		
51	1	D1-2		90 X 30	X		INSTALL ON EXISTING	MOUNT			18.75			
51	3	E5-1c		60 X 90	X		INSTALL ON EXISTING	MOUNT				37.5		
51	7	D1-2		96 X 30	X		INSTALL ON EXISTING	MOUNT			20.00			
52	1	D10-3		12 X 48	X		INSTALL ON EXISTING	MOUNT			4.0			
52	2	D10-3		12 X 48	X		INSTALL ON EXISTING	MOUNT			4.0			

ALUMINUM SIGN BLANKS THICKNESS	
Square Feet	Minimum Thickness
Less than 7.5	0.080"
7.5 to 15	0.100"
Greater than 15	0.125"

The Standard Highway Sign Designs for Texas (SHSD) can be found at the following website.
<http://www.txdot.gov/>

- NOTE:**
- Sign supports shall be located as shown on the plans, except that the Engineer may shift the sign supports, within design guidelines, where necessary to secure a more desirable location or to avoid conflict with utilities. Unless otherwise shown on the plans, the Contractor shall stake and the Engineer will verify all sign support locations.
 - For installation of bridge mount clearance signs, see Bridge Mounted Clearance Sign Assembly (BMCS) Standard Sheet.
 - For Sign Support Descriptive Codes, see Sign Mounting Details Small Roadside Signs General Notes & Details SMD(GEN).

SHEET 15 OF 35















SUMMARY OF SMALL SIGNS

SOSS

FILE: slums16.dgn	DN: TxDOT	CK: TxDOT	DW: TxDOT	CR: TxDOT
© TxDOT May 1987	CONT	SECT	JOB	HIGHWAY
REVISIONS	0095 14	033, ETC	IH 20	
4-16	DIST	COUNTY	SHEET NO.	
8-16	DAL	VARIOUS	57	

SUMMARY OF SMALL SIGNS

DISCLAIMER: The use of this standard is governed by the "Texas Engineering Practice Act". No warranty of any kind is made by TxDOT for any purpose whatsoever. TxDOT assumes no responsibility for the conversion of this standard to other formats or for incorrect results or damages resulting from its use.
 DATE: 3/20/2023 3:24:24 PM
 FILE: T:\DAL\TRAFM\FY 2023 PS&E\IH 20 Signing\IH 20 SOSS.dgn

PLAN SHEET NO.	SIGN NO.	SIGN NOMENCLATURE	SIGN	DIMENSIONS	FLAT ALUMINUM (TYPE A)	EXAL ALUMINUM (TYPE G)	SM RD SGN ASSM TY XXXXX (X) XX (X-XXXX)				BRIDGE MOUNT CLEARANCE SIGNS (See Note 2)	REPLACE ALUM SIGNS SF		
							POST TYPE	POSTS	ANCHOR TYPE	MOUNTING DESIGNATION		TY = TYPE	TYPE A	TYPE G
							FRP = Fiberglass TWT = Thin-Wall 10BWG = 10 BWG S80 = Sch 80	1 or 2	UA=Universal Conc UB=Universal Bolt SA=Slipbase-Conc SB=Slipbase-Bolt WS=Wedge Steel WP=Wedge Plastic	PREFABRICATED 1EXT or 2EXT = # of Ext BM = Extruded Wind Beam WC = 1.12 #/ft Wing Channel EXAL= Extruded Alum Sign Panels				
			IH 20 (CSJ:0095-13-044)											
52	6	E5-1c		60 X 90		X	INSTALL	ON EXISTING MOUNT				37.5		
53	1	D3-1G		66 X 12	X		INSTALL ON EXISTING	BRIDGE MOUNT		N		5.5		
53	3	E5-1c		60 X 90		X	INSTALL	ON EXISTING MOUNT				37.5		
53	6	D1-1		90 X 18		X	INSTALL	ON EXISTING MOUNT				11.25		
53	7	D3-1G		66 X 12	X		INSTALL ON EXISTING	BRIDGE MOUNT		N		5.5		
54	1	D10-3		12 X 48		X	INSTALL	ON EXISTING MOUNT				4.0		
54	2	D10-3		12 X 48		X	INSTALL	ON EXISTING MOUNT				4.0		
54	4	I-2aT		96 X 24		X	INSTALL	ON EXISTING MOUNT				16.0		
54	6	I-2aT		66 X 24		X	INSTALL	ON EXISTING MOUNT				11.0		
54	8	E5-1c		60 X 90		X	INSTALL	ON EXISTING MOUNT				37.5		
55	1	D3-1G		60 X 12	X		INSTALL	ON EXISTING MOUNT		N		5.0		
55	2	D1-1		90 X 18		X	INSTALL ON EXISTING	BRIDGE MOUNT				11.25		

ALUMINUM SIGN BLANKS THICKNESS	
Square Feet	Minimum Thickness
Less than 7.5	0.080"
7.5 to 15	0.100"
Greater than 15	0.125"

The Standard Highway Sign Designs for Texas (SHSD) can be found at the following website.
<http://www.txdot.gov/>

- NOTE:**
- Sign supports shall be located as shown on the plans, except that the Engineer may shift the sign supports, within design guidelines, where necessary to secure a more desirable location or to avoid conflict with utilities. Unless otherwise shown on the plans, the Contractor shall stake and the Engineer will verify all sign support locations.
 - For installation of bridge mount clearance signs, see Bridge Mounted Clearance Sign Assembly (BMCS) Standard Sheet.
 - For Sign Support Descriptive Codes, see Sign Mounting Details Small Roadside Signs General Notes & Details SMD(GEN).

SHEET 16 OF 35



SUMMARY OF SMALL SIGNS

SOSS

FILE: slums16.dgn	DN: TxDOT	CK: TxDOT	DW: TxDOT	CR: TxDOT
© TxDOT May 1987	CONT	SECT	JOB	HIGHWAY
REVISIONS	0095 14	033, ETC	IH 20	
4-16	DIST	COUNTY	SHEET NO.	
8-16	DAL	VARIOUS	58	

SUMMARY OF SMALL SIGNS

DATE: 3/20/2023 3:24:26 PM
 FILE: T:\DAL\TRAFFIC\2023 PS&E\IH 20 Signing\IH 20 Soss.dgn
 DISCLAIMER: The use of this standard is governed by the "Texas Engineering Practice Act". No warranty of any kind is made by TxDOT for any purpose whatsoever. TxDOT assumes no responsibility for the conversion of this standard to other formats or for incorrect results or damages resulting from its use.

PLAN SHEET NO.	SIGN NO.	SIGN NOMENCLATURE	SIGN	DIMENSIONS	FLAT ALUMINUM (TYPE A)	EXAL ALUMINUM (TYPE G)	SM RD SGN ASSM TY XXXXX (X) XX (X-XXXX)				BRIDGE MOUNT CLEARANCE SIGNS (See Note 2)	REPLACE ALUM SIGNS SF		
							POST TYPE	POSTS	ANCHOR TYPE	MOUNTING DESIGNATION		TY = TYPE	TYPE A	TYPE G
							FRP = Fiberglass TWT = Thin-Wall 10BWG = 10 BWG S80 = Sch 80	1 or 2	UA=Universal Conc UB=Universal Bolt SA=Slipbase-Conc SB=Slipbase-Bolt WS=Wedge Steel WP=Wedge Plastic	PREFABRICATED 1EXT or 2EXT = # of Ext BM = Extruded Wind Beam WC = 1.12 #/ft Wing Channel EXAL= Extruded Alum Sign Panels		TY N TY S		
			IH 20 (CSJ:0095-13-044)											
55	5	E5-1c		60 X 90		X	INSTALL	ON EXISTING MOUNT				37.5		
55	7	D1-1		84 X 18	X		10BWG	1	SA	T				
55	8	D3-1G		60 X 12	X		INSTALL ON EXISTING	BRIDGE MOUNT		N		5.0		
56	1	D10-3		12 X 48	X		INSTALL	ON EXISTING MOUNT				4.0		
56	2	D10-3		12 X 48	X		INSTALL	ON EXISTING MOUNT				4.0		
56	3	GREEN		66 X 60	X		INSTALL	ON EXISTING MOUNT				27.5		
57	2	D10-3		12 X 48	X		INSTALL	ON EXISTING MOUNT				4.0		
57	3	D10-3		12 X 48	X		INSTALL	ON EXISTING MOUNT				4.0		
57	4	D2-2		102 X 30	X		S80	1	SA	U	BM			
59	1	D10-3		12 X 48	X		INSTALL	ON EXISTING MOUNT				4.0		
59	2	D10-3		12 X 48	X		INSTALL	ON EXISTING MOUNT				4.0		
60	2	I-2dT		84 X 36	X		INSTALL	ON EXISTING MOUNT				11.0		

ALUMINUM SIGN BLANKS THICKNESS	
Square Feet	Minimum Thickness
Less than 7.5	0.080"
7.5 to 15	0.100"
Greater than 15	0.125"

The Standard Highway Sign Designs for Texas (SHSD) can be found at the following website:
<http://www.txdot.gov/>

- NOTE:**
- Sign supports shall be located as shown on the plans, except that the Engineer may shift the sign supports, within design guidelines, where necessary to secure a more desirable location or to avoid conflict with utilities. Unless otherwise shown on the plans, the Contractor shall stake and the Engineer will verify all sign support locations.
 - For installation of bridge mount clearance signs, see Bridge Mounted Clearance Sign Assembly (BMCS) Standard Sheet.
 - For Sign Support Descriptive Codes, see Sign Mounting Details Small Roadside Signs General Notes & Details SMD(GEN).

SHEET 17 OF 35













SUMMARY OF SMALL SIGNS

SOSS

FILE: slums16.dgn	DN: TxDOT	CK: TxDOT	DW: TxDOT	CR: TxDOT
© TxDOT May 1987	CONT	SECT	JOB	HIGHWAY
REVISIONS	0095 14	033, ETC	IH 20	
4-16	DIST	COUNTY	SHEET NO.	
8-16	DAL	VARIOUS	59	

SUMMARY OF SMALL SIGNS

DISCLAIMER: The use of this standard is governed by the "Texas Engineering Practice Act". No warranty of any kind is made by TxDOT for any purpose whatsoever. TxDOT assumes no responsibility for the conversion of this standard to other formats or for incorrect results or damages resulting from its use.
 DATE: 3/20/2023 3:24:28 PM
 FILE: T:\DAL\TRAFFIC\2023 PS&E\IH 20\Signing\IH 20_SOSS.dgn

PLAN SHEET NO.	SIGN NO.	SIGN NOMENCLATURE	SIGN	DIMENSIONS	FLAT ALUMINUM (TYPE A)	EXAL ALUMINUM (TYPE G)	SM RD SGN ASSM TY XXXXX (X) XX (X-XXXX)				BRIDGE MOUNT CLEARANCE SIGNS (See Note 2)	REPLACE ALUM SIGNS SF		
							POST TYPE	POSTS	ANCHOR TYPE	MOUNTING DESIGNATION		TY = TYPE	TYPE A	TYPE G
							FRP = Fiberglass TWT = Thin-Wall 10BWG = 10 BWG S80 = Sch 80	1 or 2	UA=Universal Conc UB=Universal Bolt SA=Slipbase-Conc SB=Slipbase-Bolt WS=Wedge Steel WP=Wedge Plastic	PREFABRICATED 1EXT or 2EXT = # of Ext BM = Extruded Wind Beam WC = 1.12 #/ft Wing Channel EXAL= Extruded Alum Sign Panels		TY N TY S		
			IH 20 (CSJ:0095-13-044)											
			END OF CSJ: 0095-13-044											
			BEGIN OF CSJ: 0095-14-033											
60	3	I-2aT		66 x 36	X		INSTALL ON EXISTING MOUNT					16.5		
61	1	D2-2		78 x 30	X		INSTALL ON EXISTING MOUNT					16.25		
61	2	D10-3		12 x 48	X		INSTALL ON EXISTING MOUNT					4.0		
61	3	D10-3		12 x 48	X		INSTALL ON EXISTING MOUNT					4.0		
62	1	D1-2		90 x 30	X		INSTALL ON EXISTING MOUNT					18.75		
62	2	D1-1		72 x 18	X		INSTALL ON EXISTING MOUNT					9.0		
62	3	D1-1		66 x 18	X		INSTALL ON EXISTING MOUNT					8.25		
62	5	D1-1		96 x 18	X		INSTALL ON EXISTING MOUNT					12.0		
62	6	D1-1		72 x 18	X		INSTALL ON EXISTING MOUNT					9.0		
62	7	D1-2		96 x 30	X		INSTALL ON EXISTING MOUNT					20.0		

ALUMINUM SIGN BLANKS THICKNESS	
Square Feet	Minimum Thickness
Less than 7.5	0.080"
7.5 to 15	0.100"
Greater than 15	0.125"

The Standard Highway Sign Designs for Texas (SHSD) can be found at the following website:
<http://www.txdot.gov/>

- NOTE:**
- Sign supports shall be located as shown on the plans, except that the Engineer may shift the sign supports, within design guidelines, where necessary to secure a more desirable location or to avoid conflict with utilities. Unless otherwise shown on the plans, the Contractor shall stake and the Engineer will verify all sign support locations.
 - For installation of bridge mount clearance signs, see Bridge Mounted Clearance Sign Assembly (BMCS) Standard Sheet.
 - For Sign Support Descriptive Codes, see Sign Mounting Details Small Roadside Signs General Notes & Details SMD(GEN).

SHEET 18 OF 35















SUMMARY OF SMALL SIGNS

SOSS

FILE: slums16.dgn	DN: TxDOT	CK: TxDOT	DW: TxDOT	CR: TxDOT
© TxDOT May 1987	CONT	SECT	JOB	HIGHWAY
REVISIONS	0095 14	033, ETC	IH 20	
4-16	DIST	COUNTY	SHEET NO.	
8-16	DAL	VARIOUS	60	

SUMMARY OF SMALL SIGNS

DISCLAIMER: The use of this standard is governed by the "Texas Engineering Practice Act". No warranty of any kind is made by TxDOT for any purpose whatsoever. TxDOT assumes no responsibility for the conversion of this standard to other formats or for incorrect results or damages resulting from its use.
 DATE: 3/20/2023 3:24:31 PM
 FILE: T:\DAL\TRAFFIC\2023 PS&E\IH 20\Plan Set\IH 20 Signing\IH 20 SOSS.dgn

PLAN SHEET NO.	SIGN NO.	SIGN NOMENCLATURE	SIGN	DIMENSIONS	FLAT ALUMINUM (TYPE A)	EXAL ALUMINUM (TYPE G)	SM RD SGN ASSM TY XXXXX (X) XX (X-XXXX)				BRIDGE MOUNT CLEARANCE SIGNS (See Note 2)	REPLACE ALUM SIGNS SF		
							POST TYPE	POSTS	ANCHOR TYPE	MOUNTING DESIGNATION		TY = TYPE	TYPE A	TYPE G
							FRP = Fiberglass TWT = Thin-Wall 10BWG = 10 BWG S80 = Sch 80	1 or 2	UA=Universal Conc UB=Universal Bolt SA=Slipbase-Conc SB=Slipbase-Bolt WS=Wedge Steel WP=Wedge Plastic	PREFABRICATED P = "Plain" T = "T" U = "U"		1EXT or 2EXT = # of Ext BM = Extruded Wind Beam WC = 1.12 #/ft Wing Channel EXAL= Extruded Alum Sign Panels	TY N TY S	
			IH 20 (CSJ:0095-14-033)											
63	1	E5-1C		60 X 90	X		S80	2	SA	P	EXAL			
63	2	D10-3		12 X 48	X		INSTALL ON EXISTING MOUNT					4.0		
63	3	D10-3		12 X 48	X		INSTALL ON EXISTING MOUNT					4.0		
64	1	D2-2		102 X 30	X		INSTALL ON EXISTING MOUNT					21.25		
65	1	D10-3		12 X 48	X		INSTALL ON EXISTING MOUNT					4.0		
65	2	D10-3		12 X 48	X		INSTALL ON EXISTING MOUNT					4.0		
66	2	D2-2		78 X 30	X		INSTALL ON EXISTING MOUNT					16.25		
67	1	D10-3		12 X 48	X		INSTALL ON EXISTING MOUNT					4.0		
67	2	D10-3		12 X 48	X		INSTALL ON EXISTING MOUNT					4.0		
67	3	D10-3		66 X 24	X		INSTALL ON EXISTING MOUNT					11.0		
67	5	E5-1c		60 X 90	X		S80	2	SA	P	EXAL			
67	6	D1-1		72 X 18	X		INSTALL ON EXISTING MOUNT					9.0		

ALUMINUM SIGN BLANKS THICKNESS	
Square Feet	Minimum Thickness
Less than 7.5	0.080"
7.5 to 15	0.100"
Greater than 15	0.125"

The Standard Highway Sign Designs for Texas (SHSD) can be found at the following website.
<http://www.txdot.gov/>

- NOTE:**
- Sign supports shall be located as shown on the plans, except that the Engineer may shift the sign supports, within design guidelines, where necessary to secure a more desirable location or to avoid conflict with utilities. Unless otherwise shown on the plans, the Contractor shall stake and the Engineer will verify all sign support locations.
 - For installation of bridge mount clearance signs, see Bridge Mounted Clearance Sign Assembly (BMCS) Standard Sheet.
 - For Sign Support Descriptive Codes, see Sign Mounting Details Small Roadside Signs General Notes & Details SMD(GEN).

SHEET 19 OF 35



SUMMARY OF SMALL SIGNS

SOSS

FILE: slums16.dgn	DN: TxDOT	CK: TxDOT	DW: TxDOT	CR: TxDOT
© TxDOT May 1987	CONT	SECT	JOB	HIGHWAY
REVISIONS	0095 14	033, ETC	IH 20	
4-16	DIST	COUNTY	SHEET NO.	
8-16	DAL	VARIOUS	61	

SUMMARY OF SMALL SIGNS

DISCLAIMER: The use of this standard is governed by the "Texas Engineering Practice Act". No warranty of any kind is made by TxDOT for any purpose whatsoever. TxDOT assumes no responsibility for the conversion of this standard to other formats or for incorrect results or damages resulting from its use.
 DATE: 3/20/2023 3:24:33 PM
 FILE: T:\DAL\TRAFFIC\2023 PS&E\IH 20 Signing\IH 20 Soss.dgn

PLAN SHEET NO.	SIGN NO.	SIGN NOMENCLATURE	SIGN	DIMENSIONS	FLAT ALUMINUM (TYPE A)	EXAL ALUMINUM (TYPE G)	SM RD SGN ASSM TY XXXXX (X) XX (X-XXXX)				BRIDGE MOUNT CLEARANCE SIGNS (See Note 2)	REPLACE ALUM SIGNS SF		
							POST TYPE	POSTS	ANCHOR TYPE	MOUNTING DESIGNATION		TY = TYPE	TYPE A	TYPE G
							FRP = Fiberglass TWT = Thin-Wall 10BWG = 10 BWG S80 = Sch 80	1 or 2	UA=Universal Conc UB=Universal Bolt SA=Slipbase-Conc SB=Slipbase-Bolt WS=Wedge Steel WP=Wedge Plastic	PREFABRICATED P = "Plain" T = "T" U = "U"				
			IH 20 (CSJ:0095-14-033)											
68	1	D1-1		96 X 18	X		INSTALL	ON EXISTING MOUNT				12.0		
68	2	D1-2		90 X 30	X		INSTALL	ON EXISTING MOUNT				18.75		
68	3	D1-1		72 X 18	X		INSTALL	ON EXISTING MOUNT				9.0		
68	4	D2-1		66 X 18	X		INSTALL	ON EXISTING MOUNT				8.25		
68	5	E5-1c		60 X 90	X		S80	2	SA	P	EXAL			
69	1	D10-3		12 X 48	X		INSTALL	ON EXISTING MOUNT				4.0		
69	2	D10-3		12 X 48	X		INSTALL	ON EXISTING MOUNT				4.0		
69	3	D1-2		90 X 30	X		INSTALL	ON EXISTING MOUNT				18.75		
69	4	D1-1		66 X 18	X		INSTALL	ON EXISTING MOUNT				8.25		
69	6	E5-1c		60 X 90	X		S80	2	SA	P	EXAL			
70	1	D1-2		90 X 30	X		INSTALL	ON EXISTING MOUNT				18.75		
70	2	D1-1		66 X 18	X		INSTALL	ON EXISTING MOUNT				8.25		

ALUMINUM SIGN BLANKS THICKNESS	
Square Feet	Minimum Thickness
Less than 7.5	0.080"
7.5 to 15	0.100"
Greater than 15	0.125"

The Standard Highway Sign Designs for Texas (SHSD) can be found at the following website.
<http://www.txdot.gov/>

- NOTE:**
- Sign supports shall be located as shown on the plans, except that the Engineer may shift the sign supports, within design guidelines, where necessary to secure a more desirable location or to avoid conflict with utilities. Unless otherwise shown on the plans, the Contractor shall stake and the Engineer will verify all sign support locations.
 - For installation of bridge mount clearance signs, see Bridge Mounted Clearance Sign Assembly (BMCS) Standard Sheet.
 - For Sign Support Descriptive Codes, see Sign Mounting Details Small Roadside Signs General Notes & Details SMD(GEN).

SHEET 20 OF 35



SUMMARY OF SMALL SIGNS

SOSS

FILE: slums16.dgn	DN: TxDOT	CK: TxDOT	DW: TxDOT	CK: TxDOT
© TxDOT May 1987	CONT	SECT	JOB	HIGHWAY
REVISIONS	0095 14	033, ETC	IH 20	
4-16	DIST	COUNTY	SHEET NO.	
8-16	DAL	VARIOUS	62	

SUMMARY OF SMALL SIGNS

DISCLAIMER: The use of this standard is governed by the "Texas Engineering Practice Act". No warranty of any kind is made by TxDOT for any purpose whatsoever. TxDOT assumes no responsibility for the conversion of this standard to other formats or for incorrect results or damages resulting from its use.
 DATE: 3/20/2023 3:24:35 PM
 FILE: T:\DAL\TRAFFIC\2023 PS&E\IH 20\Signing\IH 20_SOSS.dgn

PLAN SHEET NO.	SIGN NO.	SIGN NOMENCLATURE	SIGN	DIMENSIONS	FLAT ALUMINUM (TYPE A)	EXAL ALUMINUM (TYPE G)	SM RD SGN ASSM TY XXXXX (X) XX (X-XXXX)				BRIDGE MOUNT CLEARANCE SIGNS (See Note 2)	REPLACE ALUM SIGNS SF			
							POST TYPE	POSTS	ANCHOR TYPE	MOUNTING DESIGNATION		TY = TYPE	TYPE A	TYPE G	
							FRP = Fiberglass TWT = Thin-Wall 10BWG = 10 BWG S80 = Sch 80	1 or 2	UA=Universal Conc UB=Universal Bolt SA=Slipbase-Conc SB=Slipbase-Bolt WS=Wedge Steel WP=Wedge Plastic	PREFABRICATED					1EXT or 2EXT = # of Ext BM = Extruded Wind Beam WC = 1.12 #/ft Wing Channel EXAL= Extruded Alum Sign Panels
			IH 20 (CSJ:0095-14-033)												
70	3	D1-1		84 X 18	X		INSTALL	ON EXISTING MOUNT				10.5			
70	5	E5-1c		60 X 90	X		S80	2	SA	P	EXAL				
70	7	D1-1		96 X 18	X		INSTALL	ON EXISTING MOUNT				12.0			
70	8	D1-1		84 X 18	X		INSTALL	ON EXISTING MOUNT				10.5			
70	9	D1-1		96 X 18	X		INSTALL	ON EXISTING MOUNT				12.0			
71	1	D10-3		12 X 48	X		INSTALL	ON EXISTING MOUNT				4.0			
71	2	D10-3		12 X 48	X		INSTALL	ON EXISTING MOUNT				4.0			
71	3	I-2aT		42 X 24	X		INSTALL	ON EXISTING MOUNT				7.0			
71	5	D2-2		102 X 30	X		INSTALL	ON EXISTING MOUNT				21.25			
72	1	D2-2		84 X 30	X		INSTALL	ON EXISTING MOUNT				17.5			
72	2	D10-3		12 X 48	X		INSTALL	ON EXISTING MOUNT				4.0			
72	3	D10-3		12 X 48	X		INSTALL	ON EXISTING MOUNT				4.0			

ALUMINUM SIGN BLANKS THICKNESS	
Square Feet	Minimum Thickness
Less than 7.5	0.080"
7.5 to 15	0.100"
Greater than 15	0.125"

The Standard Highway Sign Designs for Texas (SHSD) can be found at the following website.
<http://www.txdot.gov/>

- NOTE:**
- Sign supports shall be located as shown on the plans, except that the Engineer may shift the sign supports, within design guidelines, where necessary to secure a more desirable location or to avoid conflict with utilities. Unless otherwise shown on the plans, the Contractor shall stake and the Engineer will verify all sign support locations.
 - For installation of bridge mount clearance signs, see Bridge Mounted Clearance Sign Assembly (BMCS) Standard Sheet.
 - For Sign Support Descriptive Codes, see Sign Mounting Details Small Roadside Signs General Notes & Details SMD(GEN).



SUMMARY OF SMALL SIGNS

SOSS

FILE: slums16.dgn	DN: TxDOT	CK: TxDOT	DW: TxDOT	CR: TxDOT
© TxDOT May 1987	CONT	SECT	JOB	HIGHWAY
REVISIONS	0095 14	033, ETC	IH 20	
4-16	DIST	COUNTY	SHEET NO.	
8-16	DAL	VARIOUS	63	

SUMMARY OF SMALL SIGNS

DISCLAIMER: The use of this standard is governed by the "Texas Engineering Practice Act". No warranty of any kind is made by TxDOT for any purpose whatsoever. TxDOT assumes no responsibility for the conversion of this standard to other formats or for incorrect results or damages resulting from its use.

PLAN SHEET NO.	SIGN NO.	SIGN NOMENCLATURE	SIGN	DIMENSIONS	FLAT ALUMINUM (TYPE A)	EXAL ALUMINUM (TYPE G)	SM RD SGN ASSM TY XXXXX (X) XX (X-XXXX)				BRIDGE MOUNT CLEARANCE SIGNS (See Note 2)	REPLACE ALUM SIGNS SF				
							POST TYPE	POSTS	ANCHOR TYPE	MOUNTING DESIGNATION		TY N	TY S	TYPE A	TYPE G	
							FRP = Fiberglass TWT = Thin-Wall 10BWG = 10 BWG S80 = Sch 80	1 or 2	UA=Universal Conc UB=Universal Bolt SA=Slipbase-Conc SB=Slipbase-Bolt WS=Wedge Steel WP=Wedge Plastic	PREFABRICATED						1EXT or 2EXT = # of Ext BM = Extruded Wind Beam WC = 1.12 #/ft Wing Channel EXAL= Extruded Alum Sign Panels
73	1	D1-2		90 x 30	X		INSTALL	ON EXISTING MOUNT					18.75			
73	2	D1-2		72 x 30	X		INSTALL	ON EXISTING MOUNT					15.0			
73	3	D1-1		66 x 18	X		INSTALL	ON EXISTING MOUNT					8.25			
73	5	E5-1c		60 x 90	X		S80	2	SA	P		EXAL				
73	6	D1-2		72 x 30	X		INSTALL	ON EXISTING MOUNT					15.0			
74	1	E5-1c		60 x 90	X		S80	2	SA	P		EXAL				
74	3	D10-3		12 x 48	X		INSTALL	ON EXISTING MOUNT					4.0			
74	4	D10-3		12 x 48	X		INSTALL	ON EXISTING MOUNT					4.0			
75	1	I-2aT		42 x 24	X		INSTALL	ON EXISTING MOUNT					7.0			
75	2	D2-2		102 x 30	X		INSTALL	ON EXISTING MOUNT					21.25			
76	2	D10-3		12 x 48	X		INSTALL	ON EXISTING MOUNT					4.0			
76	3	D10-3		12 x 48	X		INSTALL	ON EXISTING MOUNT					4.0			

ALUMINUM SIGN BLANKS THICKNESS	
Square Feet	Minimum Thickness
Less than 7.5	0.080"
7.5 to 15	0.100"
Greater than 15	0.125"

The Standard Highway Sign Designs for Texas (SHSD) can be found at the following website.
<http://www.txdot.gov/>

- NOTE:**
- Sign supports shall be located as shown on the plans, except that the Engineer may shift the sign supports, within design guidelines, where necessary to secure a more desirable location or to avoid conflict with utilities. Unless otherwise shown on the plans, the Contractor shall stake and the Engineer will verify all sign support locations.
 - For installation of bridge mount clearance signs, see Bridge Mounted Clearance Sign Assembly (BMCS) Standard Sheet.
 - For Sign Support Descriptive Codes, see Sign Mounting Details Small Roadside Signs General Notes & Details SMD(GEN).

SHEET 22 OF 35















SUMMARY OF SMALL SIGNS

SOSS

FILE: slums16.dgn	DN: TxDOT	CK: TxDOT	DW: TxDOT	CR: TxDOT
© TxDOT May 1987	CONT	SECT	JOB	HIGHWAY
REVISIONS	0095 14	033, ETC	IH 20	
4-16	DIST	COUNTY	SHEET NO.	
8-16	DAL	VARIOUS	64	

SUMMARY OF SMALL SIGNS

DISCLAIMER: The use of this standard is governed by the "Texas Engineering Practice Act". No warranty of any kind is made by TxDOT for any purpose whatsoever. TxDOT assumes no responsibility for the conversion of this standard to other formats or for incorrect results or damages resulting from its use.
 DATE: 3/20/2023 3:24:39 PM
 FILE: T:\DAL\TRAFFIC\2023 PS&E\IH 20\Signing\IH 20_SOSS.dgn

PLAN SHEET NO.	SIGN NO.	SIGN NOMENCLATURE	SIGN	DIMENSIONS	FLAT ALUMINUM (TYPE A)	EXAL ALUMINUM (TYPE G)	SM RD SGN ASSM TY XXXXX (X) XX (X-XXXX)				BRIDGE MOUNT CLEARANCE SIGNS (See Note 2)	REPLACE ALUM SIGNS SF		
							POST TYPE	POSTS	ANCHOR TYPE	MOUNTING DESIGNATION		TY = TYPE	TYPE A	TYPE G
							FRP = Fiberglass TWT = Thin-Wall 10BWG = 10 BWG S80 = Sch 80	1 or 2	UA=Universal Conc UB=Universal Bolt SA=Slipbase-Conc SB=Slipbase-Bolt WS=Wedge Steel WP=Wedge Plastic	PREFABRICATED 1EXT or 2EXT = # of Ext BM = Extruded Wind Beam WC = 1.12 #/ft Wing Channel EXAL= Extruded Alum Sign Panels		TY N TY S		
			IH 20 (CSJ:0095-14-033)											
78	1	D10-3		12 X 48	X		INSTALL	ON EXISTING MOUNT				4.0		
78	2	D10-3		12 X 48	X		INSTALL	ON EXISTING MOUNT				4.0		
80	1	D10-3		12 X 48	X		INSTALL	ON EXISTING MOUNT				4.0		
80	2	D10-3		12 X 48	X		INSTALL	ON EXISTING MOUNT				4.0		
81	1	D2-2		78 X 30	X		INSTALL	ON EXISTING MOUNT				16.25		
81	2	I-2aT		54 X 24	X		INSTALL	ON EXISTING MOUNT				9.0		
81	3	GREEN		138 X 54	X		INSTALL	ON EXISTING MOUNT				51.75		
82	1	D10-3		12 X 48	X		INSTALL	ON EXISTING MOUNT				4.0		
82	2	D10-3		12 X 48	X		INSTALL	ON EXISTING MOUNT				4.0		
82	3	D1-2		90 X 30	X		INSTALL	ON EXISTING MOUNT				18.75		
82	4	D1-1		66 X 18	X		INSTALL	ON EXISTING MOUNT				8.25		
82	6	E5-1c		60 X 90	X		S80	2	SA	P	EXAL			

ALUMINUM SIGN BLANKS THICKNESS	
Square Feet	Minimum Thickness
Less than 7.5	0.080"
7.5 to 15	0.100"
Greater than 15	0.125"

The Standard Highway Sign Designs for Texas (SHSD) can be found at the following website.
<http://www.txdot.gov/>

- NOTE:**
- Sign supports shall be located as shown on the plans, except that the Engineer may shift the sign supports, within design guidelines, where necessary to secure a more desirable location or to avoid conflict with utilities. Unless otherwise shown on the plans, the Contractor shall stake and the Engineer will verify all sign support locations.
 - For installation of bridge mount clearance signs, see Bridge Mounted Clearance Sign Assembly (BMCS) Standard Sheet.
 - For Sign Support Descriptive Codes, see Sign Mounting Details Small Roadside Signs General Notes & Details SMD(GEN).

SHEET 23 OF 35



SUMMARY OF SMALL SIGNS

SOSS

FILE: slms16.dgn	DN: TxDOT	CK: TxDOT	DW: TxDOT	CR: TxDOT
© TxDOT May 1987	CONT	SECT	JOB	HIGHWAY
REVISIONS	0095 14	033, ETC	IH 20	
4-16	DIST	COUNTY	SHEET NO.	
8-16	DAL	VARIOUS	65	

SUMMARY OF SMALL SIGNS

DISCLAIMER: The use of this standard is governed by the "Texas Engineering Practice Act". No warranty of any kind is made by TxDOT for any purpose whatsoever. TxDOT assumes no responsibility for the conversion of this standard to other formats or for incorrect results or damages resulting from its use.

PLAN SHEET NO.	SIGN NO.	SIGN NOMENCLATURE	SIGN	DIMENSIONS	FLAT ALUMINUM (TYPE A)	EXAL ALUMINUM (TYPE G)	SM RD SGN ASSM TY XXXXX (X) XX (X-XXXX)				BRIDGE MOUNT CLEARANCE SIGNS (See Note 2)	REPLACE ALUM SIGNS SF		
							POST TYPE	POSTS	ANCHOR TYPE	MOUNTING DESIGNATION		TY = TYPE	TYPE A	TYPE G
			IH 20 (CSJ:0095-14-033)											
82	7	D1-1		78 x 18	X		INSTALL	ON EXISTING MOUNT					9.75	
82	8	D1-2		96 x 30	X		INSTALL	ON EXISTING MOUNT					20.0	
82	10	D1-1		96 x 18	X		INSTALL	ON EXISTING MOUNT					12.0	
83	1	D2-2		84 x 30	X		INSTALL	ON EXISTING MOUNT					17.5	
83	2	E5-1c		60 x 90	X		S80	2	SA	P	EXAL			
84	1	D10-3		12 x 48	X		INSTALL	ON EXISTING MOUNT					4.0	
84	2	D10-3		12 x 48	X		INSTALL	ON EXISTING MOUNT					4.0	
84	8	E5-1c		72 x 90	X		S80	2	SA	P	EXAL			
84	9	E5-1c		72 x 90	X		S80	2	SA	P	EXAL			
			END OF CSJ: 0095-14-033											
			BEGIN OF CSJ: 0495-01-079											
85	2	D1-2		90 x 30	X		INSTALL	ON EXISTING MOUNT					18.75	

ALUMINUM SIGN BLANKS THICKNESS	
Square Feet	Minimum Thickness
Less than 7.5	0.080"
7.5 to 15	0.100"
Greater than 15	0.125"

The Standard Highway Sign Designs for Texas (SHSD) can be found at the following website.
<http://www.txdot.gov/>

- NOTE:**
- Sign supports shall be located as shown on the plans, except that the Engineer may shift the sign supports, within design guidelines, where necessary to secure a more desirable location or to avoid conflict with utilities. Unless otherwise shown on the plans, the Contractor shall stake and the Engineer will verify all sign support locations.
 - For installation of bridge mount clearance signs, see Bridge Mounted Clearance Sign Assembly (BMCS) Standard Sheet.
 - For Sign Support Descriptive Codes, see Sign Mounting Details Small Roadside Signs General Notes & Details SMD(GEN).

SHEET 24 OF 35



SUMMARY OF SMALL SIGNS

SOSS

FILE: slums16.dgn	DN: TxDOT	CK: TxDOT	DW: TxDOT	CK: TxDOT
© TxDOT May 1987	CONT	SECT	JOB	HIGHWAY
REVISIONS	0095 14	033, ETC	IH 20	
4-16	DIST	COUNTY	SHEET NO.	
8-16	DAL	VARIOUS	66	

SUMMARY OF SMALL SIGNS

DISCLAIMER: The use of this standard is governed by the "Texas Engineering Practice Act". No warranty of any kind is made by TxDOT for any purpose whatsoever. TxDOT assumes no responsibility for the conversion of this standard to other formats or for incorrect results or damages resulting from its use.
 DATE: 3/20/2023 3:24:43 PM
 FILE: T:\DAL\TRAFM\FY 2023 PS&E\IH 20\Signing\IH 20 SOSS.dgn

PLAN SHEET NO.	SIGN NO.	SIGN NOMENCLATURE	SIGN	DIMENSIONS	FLAT ALUMINUM (TYPE A)	EXAL ALUMINUM (TYPE G)	SM RD SGN ASSM TY XXXXX (X) XX (X-XXXX)				BRIDGE MOUNT CLEARANCE SIGNS (See Note 2)	REPLACE ALUM SIGNS SF		
							POST TYPE	POSTS	ANCHOR TYPE	MOUNTING DESIGNATION		TY = TYPE	TYPE A	TYPE G
							FRP = Fiberglass TWT = Thin-Wall 10BWG = 10 BWG S80 = Sch 80	1 or 2	UA=Universal Conc UB=Universal Bolt SA=Slipbase-Conc SB=Slipbase-Bolt WS=Wedge Steel WP=Wedge Plastic	PREFABRICATED P = "Plain" T = "T" U = "U"		1EXT or 2EXT = # of Ext BM = Extruded Wind Beam WC = 1.12 #/ft Wing Channel EXAL= Extruded Alum Sign Panels	TY N TY S	
85	3	D1-1		66 X 18	X		INSTALL	ON EXISTING MOUNT				8.25		
85	5	E5-1c		72 X 90	X		S80	2	SA	P	EXAL			
85	7	D1-1		72 X 18			INSTALL	ON EXISTING MOUNT				9.0		
85	8	D1-1		96 X 18			INSTALL	ON EXISTING MOUNT				12.0		
85	9	D1-2		96 X 30	X		INSTALL	ON EXISTING MOUNT				20.0		
86	1	D10-3		12 X 48	X		INSTALL	ON EXISTING MOUNT				4.0		
86	2	D10-3		12 X 48	X		INSTALL	ON EXISTING MOUNT				4.0		
87	1	D2-1		66 X 18	X		INSTALL	ON EXISTING MOUNT				8.25		
87	4	D2-3		102 X 42	X		INSTALL	ON EXISTING MOUNT				29.75		
87	6	E5-1c		60 X 90	X		S80	2	SA	P	EXAL			
88	1	D10-3		12 X 48	X		INSTALL	ON EXISTING MOUNT				4.0		
88	2	D10-3		12 X 48	X		INSTALL	ON EXISTING MOUNT				4.0		

ALUMINUM SIGN BLANKS THICKNESS	
Square Feet	Minimum Thickness
Less than 7.5	0.080"
7.5 to 15	0.100"
Greater than 15	0.125"

The Standard Highway Sign Designs for Texas (SHSD) can be found at the following website.
<http://www.txdot.gov/>

NOTE:

1. Sign supports shall be located as shown on the plans, except that the Engineer may shift the sign supports, within design guidelines, where necessary to secure a more desirable location or to avoid conflict with utilities. Unless otherwise shown on the plans, the Contractor shall stake and the Engineer will verify all sign support locations.
2. For installation of bridge mount clearance signs, see Bridge Mounted Clearance Sign Assembly (BMCS) Standard Sheet.
3. For Sign Support Descriptive Codes, see Sign Mounting Details Small Roadside Signs General Notes & Details SMD(GEN).

SHEET 25 OF 35

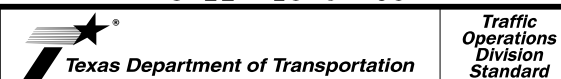

SUMMARY OF SMALL SIGNS

SOSS

FILE: slums16.dgn	DN: TxDOT	CK: TxDOT	DW: TxDOT	CR: TxDOT
© TxDOT May 1987	CONT	SECT	JOB	HIGHWAY
REVISIONS	0095	14	033, ETC	IH 20
4-16	DIST	COUNTY	SHEET NO.	
8-16	DAL	VARIOUS	67	

SUMMARY OF SMALL SIGNS

DATE: 3/20/2023 3:24:45 PM
 FILE: T:\DAL\TRAFFIC\2023 PS&E\IH 20\Signing\IH 20_SOSS.dgn
 DISCLAIMER: The use of this standard is governed by the "Texas Engineering Practice Act". No warranty of any kind is made by TxDOT for any purpose whatsoever. TxDOT assumes no responsibility for the conversion of this standard to other formats or for incorrect results or damages resulting from its use.

PLAN SHEET NO.	SIGN NO.	SIGN NOMENCLATURE	SIGN	DIMENSIONS	FLAT ALUMINUM (TYPE A)	EXAL ALUMINUM (TYPE G)	SM RD SGN ASSM TY XXXXX (X) XX (X-XXXX)				BRIDGE MOUNT CLEARANCE SIGNS (See Note 2)	REPLACE ALUM SIGNS SF		
							POST TYPE	POSTS	ANCHOR TYPE	MOUNTING DESIGNATION		TY = TYPE	TYPE A	TYPE G
							FRP = Fiberglass TWT = Thin-Wall 10BWG = 10 BWG S80 = Sch 80	1 or 2	UA=Universal Conc UB=Universal Bolt SA=Slipbase-Conc SB=Slipbase-Bolt WS=Wedge Steel WP=Wedge Plastic	PREFABRICATED 1EXT or 2EXT = # of Ext BM = Extruded Wind Beam WC = 1.12 #/ft Wing Channel EXAL= Extruded Alum Sign Panels		TY N TY S		
88	3	D1-3		90 x 42	X		INSTALL	ON EXISTING MOUNT				26.25		
88	4	I-5 D9-1dP (GREEN)		24 x 24 24 x 6	X X		INSTALL	ON EXISTING MOUNT				4.0 1.0		
88	5	D1-3		96 x 42	X		INSTALL	ON EXISTING MOUNT				28.0		
88	6	D1-2		72 x 30	X		INSTALL	ON EXISTING MOUNT				15.0		
88	7	D1-2		84 x 30	X		INSTALL	ON EXISTING MOUNT				17.5		
88	8	D1-2		96 x 30	X		INSTALL	ON EXISTING MOUNT				20.0		
88	9	D1-3		96 x 42	X		INSTALL	ON EXISTING MOUNT				28.0		
88	10	D1-2		84 x 30	X		INSTALL	ON EXISTING MOUNT				17.5		
88	11	D1-2		96 x 30	X		INSTALL	ON EXISTING MOUNT				20.0		
89	1	E5-1c		60 x 90	X		S80	2	SA	P	EXAL			
90	1	D10-3		12 x 48	X		INSTALL	ON EXISTING MOUNT				4.0		
90	2	D10-3		12 x 48	X		INSTALL	ON EXISTING MOUNT				4.0		

ALUMINUM SIGN BLANKS THICKNESS	
Square Feet	Minimum Thickness
Less than 7.5	0.080"
7.5 to 15	0.100"
Greater than 15	0.125"

The Standard Highway Sign Designs for Texas (SHSD) can be found at the following website:
<http://www.txdot.gov/>

- NOTE:**
- Sign supports shall be located as shown on the plans, except that the Engineer may shift the sign supports, within design guidelines, where necessary to secure a more desirable location or to avoid conflict with utilities. Unless otherwise shown on the plans, the Contractor shall stake and the Engineer will verify all sign support locations.
 - For installation of bridge mount clearance signs, see Bridge Mounted Clearance Sign Assembly (BMCS) Standard Sheet.
 - For Sign Support Descriptive Codes, see Sign Mounting Details Small Roadside Signs General Notes & Details SMD(GEN).

SHEET 26 OF 35















SUMMARY OF SMALL SIGNS

SOSS

FILE: slums16.dgn	DN: TxDOT	CK: TxDOT	DW: TxDOT	CR: TxDOT
© TxDOT May 1987	CONT	SECT	JOB	HIGHWAY
REVISIONS	0095	14	033, ETC	IH 20
4-16	DIST	COUNTY	SHEET NO.	
8-16	DAL	VARIOUS	68	

SUMMARY OF SMALL SIGNS

DATE: 3/20/2023 3:24:47 PM
 FILE: T:\DAL\TRAFMAY 2023 PS&E\IH 20\Signing\IH 20 S055.dgn
 PS&E\IH 20\Signing\IH 20 S055.dgn
 The use of this standard is governed by the "Texas Engineering Practice Act". No warranty of any kind is made by TxDOT for any purpose whatsoever. TxDOT assumes no responsibility for the conversion of this standard to other formats or for incorrect results or damages resulting from its use.

PLAN SHEET NO.	SIGN NO.	SIGN NOMENCLATURE	SIGN	DIMENSIONS	FLAT ALUMINUM (TYPE A)	EXAL ALUMINUM (TYPE G)	SM RD SGN ASSM TY XXXXX (X) XX (X-XXXX)				BRIDGE MOUNT CLEARANCE SIGNS (See Note 2)	REPLACE ALUM SIGNS SF		
							POST TYPE	POSTS	ANCHOR TYPE	MOUNTING DESIGNATION		TY = TYPE	TYPE A	TYPE G
							FRP = Fiberglass TWT = Thin-Wall 10BWG = 10 BWG S80 = Sch 80	1 or 2	UA=Universal Conc UB=Universal Bolt SA=Slipbase-Conc SB=Slipbase-Bolt WS=Wedge Steel WP=Wedge Plastic	PREFABRICATED P = "Plain" T = "T" U = "U"				
			IH 20 (CSJ:0495-01-079)											
90	3	D2-2		84 X 30	X		INSTALL	ON EXISTING MOUNT				17.5		
90	4	E5-1c		60 X 90	X		S80	2	SA	P	EXAL			
91	1	D10-3		12 X 48	X		INSTALL	ON EXISTING MOUNT				4.0		
91	2	D10-3		12 X 48	X		INSTALL	ON EXISTING MOUNT				4.0		
92	1	GREEN		138 X 54	X		S80	2	SA	P	EXAL			
92	2	R3-8 (MOD)		30 X 36	X		10BWG	1	SA	P				
92	3	E5-1c		60 X 90	X		S80	2	SA	P	EXAL			
93	2	D10-3		12 X 48	X		INSTALL	ON EXISTING MOUNT				4.0		
93	3	D10-3		12 X 48	X		INSTALL	ON EXISTING MOUNT				4.0		
94	2	D2-2		102 X 30	X		INSTALL	ON EXISTING MOUNT				21.25		
95	1	D10-3		12 X 48	X		INSTALL	ON EXISTING MOUNT				4.0		
95	2	D10-3		12 X 48	X		INSTALL	ON EXISTING MOUNT				4.0		

ALUMINUM SIGN BLANKS THICKNESS	
Square Feet	Minimum Thickness
Less than 7.5	0.080"
7.5 to 15	0.100"
Greater than 15	0.125"

The Standard Highway Sign Designs for Texas (SHSD) can be found at the following website.
<http://www.txdot.gov/>

- NOTE:**
- Sign supports shall be located as shown on the plans, except that the Engineer may shift the sign supports, within design guidelines, where necessary to secure a more desirable location or to avoid conflict with utilities. Unless otherwise shown on the plans, the Contractor shall stake and the Engineer will verify all sign support locations.
 - For installation of bridge mount clearance signs, see Bridge Mounted Clearance Sign Assembly (BMCS) Standard Sheet.
 - For Sign Support Descriptive Codes, see Sign Mounting Details Small Roadside Signs General Notes & Details SMD(GEN).

SHEET 27 OF 35















SUMMARY OF SMALL SIGNS

SOSS

FILE: slums16.dgn	DN: TxDOT	CK: TxDOT	DW: TxDOT	CR: TxDOT
© TxDOT May 1987	CONT	SECT	JOB	HIGHWAY
REVISIONS	0095	14	033, ETC	IH 20
4-16	DIST	COUNTY	SHEET NO.	
8-16	DAL	VARIOUS	69	

SUMMARY OF SMALL SIGNS

DISCLAIMER: The use of this standard is governed by the "Texas Engineering Practice Act". No warranty of any kind is made by TxDOT for any purpose whatsoever. TxDOT assumes no responsibility for the conversion of this standard to other formats or for incorrect results or damages resulting from its use.
 DATE: 3/20/2023 3:24:49 PM
 FILE: T:\DAL\TRAFFIC\2023 PS&E\IH 20 Signing\IH 20 Signing\IH 20 SSS.dgn

PLAN SHEET NO.	SIGN NO.	SIGN NOMENCLATURE	SIGN	DIMENSIONS	FLAT ALUMINUM (TYPE A)	EXAL ALUMINUM (TYPE G)	SM RD SGN ASSM TY XXXXX (X) XX (X-XXXX)				BRIDGE MOUNT CLEARANCE SIGNS (See Note 2)	REPLACE ALUM SIGNS SF		
							POST TYPE	POSTS	ANCHOR TYPE	MOUNTING DESIGNATION		TY = TYPE	TYPE A	TYPE G
							FRP = Fiberglass TWT = Thin-Wall 10BWG = 10 BWG S80 = Sch 80	1 or 2	UA=Universal Conc UB=Universal Bolt SA=Slipbase-Conc SB=Slipbase-Bolt WS=Wedge Steel WP=Wedge Plastic	PREFABRICATED 1EXT or 2EXT = # of Ext BM = Extruded Wind Beam WC = 1.12 #/ft Wing Channel EXAL= Extruded Alum Sign Panels		TY N TY S		
96	1	D2-1		66 X 18	X		INSTALL	ON EXISTING MOUNT				8.25		
97	1	D1-2		90 X 30	X		INSTALL	ON EXISTING MOUNT				18.75		
97	2	D10-3		12 X 48	X		INSTALL	ON EXISTING MOUNT				4.0		
97	3	D10-3		12 X 48	X		INSTALL	ON EXISTING MOUNT				4.0		
97	4	D-1		66 X 18	X		INSTALL	ON EXISTING MOUNT				8.25		
97	5	D1-1		96 X 18	X		INSTALL	ON EXISTING MOUNT				12.0		
97	6	D1-2		96 X 30	X		INSTALL	ON EXISTING MOUNT				20.0		
98	1	E5-1c		60 X 90		X	S80	2	SA	P	EXAL			
99	1	D10-3		12 X 48	X		INSTALL	ON EXISTING MOUNT				4.0		
99	2	D10-3		12 X 48	X		INSTALL	ON EXISTING MOUNT				4.0		
99	4	D2-1		102 X 18	X		10BWG	1	SA	T	2EXT			
101	1	D10-3		12 X 48	X		INSTALL	ON EXISTING MOUNT				4.0		

ALUMINUM SIGN BLANKS THICKNESS	
Square Feet	Minimum Thickness
Less than 7.5	0.080"
7.5 to 15	0.100"
Greater than 15	0.125"

The Standard Highway Sign Designs for Texas (SHSD) can be found at the following website:
<http://www.txdot.gov/>

- NOTE:**
- Sign supports shall be located as shown on the plans, except that the Engineer may shift the sign supports, within design guidelines, where necessary to secure a more desirable location or to avoid conflict with utilities. Unless otherwise shown on the plans, the Contractor shall stake and the Engineer will verify all sign support locations.
 - For installation of bridge mount clearance signs, see Bridge Mounted Clearance Sign Assembly (BMCS) Standard Sheet.
 - For Sign Support Descriptive Codes, see Sign Mounting Details Small Roadside Signs General Notes & Details SMD(GEN).

SHEET 28 OF 35



SUMMARY OF SMALL SIGNS

SOSS

FILE: slums16.dgn	DN: TxDOT	CK: TxDOT	DW: TxDOT	CR: TxDOT
© TxDOT May 1987	CONT	SECT	JOB	HIGHWAY
REVISIONS	0095	14	033, ETC	IH 20
4-16	DIST	COUNTY	SHEET NO.	
8-16	DAL	VARIOUS	70	

SUMMARY OF SMALL SIGNS

DISCLAIMER: The use of this standard is governed by the "Texas Engineering Practice Act". No warranty of any kind is made by TxDOT for any purpose whatsoever. TxDOT assumes no responsibility for the conversion of this standard to other formats or for incorrect results or damages resulting from its use.
 DATE: 3/20/2023 3:24:51 PM
 FILE: T:\DAL\TRAFFIC\2023 PS&E\IH 20\Signing\IH 20_SOSS.dgn

PLAN SHEET NO.	SIGN NO.	SIGN NOMENCLATURE	SIGN	DIMENSIONS	FLAT ALUMINUM (TYPE A)	EXAL ALUMINUM (TYPE G)	SM RD SGN ASSM TY XXXXX (X) XX (X-XXXX)				BRIDGE MOUNT CLEARANCE SIGNS (See Note 2)	REPLACE ALUM SIGNS SF		
							POST TYPE	POSTS	ANCHOR TYPE	MOUNTING DESIGNATION		TY = TYPE	TYPE A	TYPE G
							FRP = Fiberglass TWT = Thin-Wall 10BWG = 10 BWG S80 = Sch 80	1 or 2	UA=Universal Conc UB=Universal Bolt SA=Slipbase-Conc SB=Slipbase-Bolt WS=Wedge Steel WP=Wedge Plastic	PREFABRICATED P = "Plain" T = "T" U = "U"		1EXT or 2EXT = # of Ext BM = Extruded Wind Beam WC = 1.12 #/ft Wing Channel EXAL= Extruded Alum Sign Panels	TY N TY S	
			IH 20 (CSJ:0495-01-079)											
101	2	D10-3		12 X 48	X		INSTALL	ON EXISTING MOUNT				4.0		
101	3	D2-2		78 X 30	X		INSTALL	ON EXISTING MOUNT				16.25		
102	2	E5-1c		60 X 90	X		S80	2	SA	P	EXAL			
103	1	D10-3		12 X 48	X		INSTALL	ON EXISTING MOUNT				4.0		
103	2	D10-3		12 X 48	X		INSTALL	ON EXISTING MOUNT				4.0		
103	3	R3-6R		30 X 36	X		10BWG	1	SA	P				
103	4	D1-1		78 X 18	X		INSTALL	ON EXISTING MOUNT				9.75		
103	5	E5-1c		60 X 90	X		S80	2	SA	P	EXAL			
105	1	D10-3		12 X 48	X		INSTALL	ON EXISTING MOUNT				4.0		
105	2	D10-3		12 X 48	X		INSTALL	ON EXISTING MOUNT				4.0		
107	1	D10-3		12 X 48	X		INSTALL	ON EXISTING MOUNT				4.0		
107	2	D10-3		12 X 48	X		INSTALL	ON EXISTING MOUNT				4.0		

ALUMINUM SIGN BLANKS THICKNESS	
Square Feet	Minimum Thickness
Less than 7.5	0.080"
7.5 to 15	0.100"
Greater than 15	0.125"

The Standard Highway Sign Designs for Texas (SHSD) can be found at the following website:
<http://www.txdot.gov/>

- NOTE:**
- Sign supports shall be located as shown on the plans, except that the Engineer may shift the sign supports, within design guidelines, where necessary to secure a more desirable location or to avoid conflict with utilities. Unless otherwise shown on the plans, the Contractor shall stake and the Engineer will verify all sign support locations.
 - For installation of bridge mount clearance signs, see Bridge Mounted Clearance Sign Assembly (BMCS) Standard Sheet.
 - For Sign Support Descriptive Codes, see Sign Mounting Details Small Roadside Signs General Notes & Details SMD(GEN).

SHEET 29 OF 35



SUMMARY OF SMALL SIGNS

SOSS

FILE: slums16.dgn	DN: TxDOT	CK: TxDOT	DW: TxDOT	CR: TxDOT
© TxDOT May 1987	CONT	SECT	JOB	HIGHWAY
REVISIONS	0095	14	033, ETC	IH 20
4-16	DIST	COUNTY	SHEET NO.	
8-16	DAL	VARIOUS	71	

SUMMARY OF SMALL SIGNS

DISCLAIMER: The use of this standard is governed by the "Texas Engineering Practice Act". No warranty of any kind is made by TxDOT for any purpose whatsoever. TxDOT assumes no responsibility for the conversion of this standard to other formats or for incorrect results or damages resulting from its use.
 DATE: 3/20/2023 3:24:53 PM
 FILE: T:\DAL\TRAFFIC\2023 PS&E\IH 20 Signing\IH 20 Soss.dgn

PLAN SHEET NO.	SIGN NO.	SIGN NOMENCLATURE	SIGN	DIMENSIONS	FLAT ALUMINUM (TYPE A)	EXAL ALUMINUM (TYPE G)	SM RD SGN ASSM TY XXXXX (X) XX (X-XXXX)				BRIDGE MOUNT CLEARANCE SIGNS (See Note 2)	REPLACE ALUM SIGNS SF		
							POST TYPE	POSTS	ANCHOR TYPE	MOUNTING DESIGNATION		TY = TYPE	TYPE A	TYPE G
							FRP = Fiberglass TWT = Thin-Wall 10BWG = 10 BWG S80 = Sch 80	1 or 2	UA=Universal Conc UB=Universal Bolt SA=Slipbase-Conc SB=Slipbase-Bolt WS=Wedge Steel WP=Wedge Plastic	PREFABRICATED P = "Plain" T = "T" U = "U"		1EXT or 2EXT = # of Ext BM = Extruded Wind Beam WC = 1.12 #/ft Wing Channel EXAL= Extruded Alum Sign Panels	TY N TY S	
			IH 20 (CSJ:0495-01-079)											
108	1	D10-3		12 X 48	X		INSTALL	ON EXISTING MOUNT				4.0		
108	3	E5-1c		60 X 90	X		S80	2	SA	P	EXAL			
109	1	D1-1		66 X 18	X		INSTALL	ON EXISTING MOUNT				8.25		
109	2	D1-2		96 X 30	X		INSTALL	ON EXISTING MOUNT				20.0		
109	3	E5-1c		60 X 90	X		S80	2	SA	P	EXAL			
109	4	D10-3		12 X 48	X		INSTALL	ON EXISTING MOUNT				4.0		
109	5	D1-2		96 X 30	X		INSTALL	ON EXISTING MOUNT				20.0		
109	6	D1-1		96 X 18	X		INSTALL	ON EXISTING MOUNT				12.0		
110	2	D10-3		12 X 48	X		INSTALL	ON EXISTING MOUNT				4.0		
110	3	D10-3		12 X 48	X		INSTALL	ON EXISTING MOUNT				4.0		
110	4	D2-2		96 X 30	X		S80	1	SA	U	BM			

ALUMINUM SIGN BLANKS THICKNESS	
Square Feet	Minimum Thickness
Less than 7.5	0.080"
7.5 to 15	0.100"
Greater than 15	0.125"

The Standard Highway Sign Designs for Texas (SHSD) can be found at the following website.
<http://www.txdot.gov/>

- NOTE:**
- Sign supports shall be located as shown on the plans, except that the Engineer may shift the sign supports, within design guidelines, where necessary to secure a more desirable location or to avoid conflict with utilities. Unless otherwise shown on the plans, the Contractor shall stake and the Engineer will verify all sign support locations.
 - For installation of bridge mount clearance signs, see Bridge Mounted Clearance Sign Assembly (BMCS) Standard Sheet.
 - For Sign Support Descriptive Codes, see Sign Mounting Details Small Roadside Signs General Notes & Details SMD(GEN).

SHEET 30 OF 35





SUMMARY OF SMALL SIGNS

SOSS

FILE: slums16.dgn	DN: TxDOT	CK: TxDOT	DW: TxDOT	CR: TxDOT
© TxDOT May 1987	CONT	SECT	JOB	HIGHWAY
REVISIONS	0095	14	033, ETC	IH 20
4-16	DIST	COUNTY	SHEET NO.	
8-16	DAL	VARIOUS	72	

SUMMARY OF SMALL SIGNS

DISCLAIMER: The use of this standard is governed by the "Texas Engineering Practice Act". No warranty of any kind is made by TxDOT for any purpose whatsoever. TxDOT assumes no responsibility for the conversion of any kind of this standard to other formats or for incorrect results or damages resulting from its use.
 DATE: 3/20/2023 3:24:55 PM
 FILE: T:\DAL\TRAFM\FY 2023 PS&E\IH 20\Plan Set\IH 20 Signing\IH 20 SOSS.dgn

PLAN SHEET NO.	SIGN NO.	SIGN NOMENCLATURE	SIGN	DIMENSIONS	FLAT ALUMINUM (TYPE A)	EXAL ALUMINUM (TYPE G)	SM RD SGN ASSM TY XXXXX (X) XX (X-XXXX)				BRIDGE MOUNT CLEARANCE SIGNS (See Note 2)	REPLACE ALUM SIGNS SF		
							POST TYPE	POSTS	ANCHOR TYPE	MOUNTING DESIGNATION		TY = TYPE	TYPE A	TYPE G
							FRP = Fiberglass TWT = Thin-Wall 10BWG = 10 BWG S80 = Sch 80	1 or 2	UA=Universal Conc UB=Universal Bolt SA=Slipbase-Conc SB=Slipbase-Bolt WS=Wedge Steel WP=Wedge Plastic	PREFABRICATED 1EXT or 2EXT = # of Ext BM = Extruded Wind Beam WC = 1.12 #/ft Wing Channel EXAL= Extruded Alum Sign Panels		TY N TY S		
111	1	I-2dT	 	84 x 36	X							11.0		
		R19-10dT		24 x 24	X								4.0	
111	2	I-2dT		96 x 36	X								24.0	
			END OF CSJ: 0495-01-079											

ALUMINUM SIGN BLANKS THICKNESS	
Square Feet	Minimum Thickness
Less than 7.5	0.080"
7.5 to 15	0.100"
Greater than 15	0.125"

The Standard Highway Sign Designs for Texas (SHSD) can be found at the following website:
<http://www.txdot.gov/>

- NOTE:**
- Sign supports shall be located as shown on the plans, except that the Engineer may shift the sign supports, within design guidelines, where necessary to secure a more desirable location or to avoid conflict with utilities. Unless otherwise shown on the plans, the Contractor shall stake and the Engineer will verify all sign support locations.
 - For installation of bridge mount clearance signs, see Bridge Mounted Clearance Sign Assembly (BMCS) Standard Sheet.
 - For Sign Support Descriptive Codes, see Sign Mounting Details Small Roadside Signs General Notes & Details SMD(GEN).

SHEET 31 OF 35













SUMMARY OF SMALL SIGNS

SOSS

FILE: slms16.dgn	DN: TxDOT	CK: TxDOT	DW: TxDOT	CR: TxDOT
© TxDOT May 1987	CONT	SECT	JOB	HIGHWAY
REVISIONS	0095	14	033, ETC	IH 20
4-16	DIST	COUNTY	SHEET NO.	
8-16	DAL	VARIOUS	73	

SUMMARY OF SMALL SIGNS

DATE: 3/20/2023 3:24:58 PM
 FILE: T:\DAL\TRAFFIC\2023 PS&E\IH 20\Signing\IH 20 SOSS.dgn
 DISCLAIMER: The use of this standard is governed by the "Texas Engineering Practice Act". No warranty of any kind is made by TxDOT for any purpose whatsoever. TxDOT assumes no responsibility for the conversion of this standard to other formats or for incorrect results or damages resulting from its use.

PLAN SHEET NO.	SIGN NO.	SIGN NOMENCLATURE	SIGN	DIMENSIONS	FLAT ALUMINUM (TYPE A)	EXAL ALUMINUM (TYPE G)	SM RD SGN ASSM TY XXXXX (X) XX (X-XXXX)				BRIDGE MOUNT CLEARANCE SIGNS (See Note 2)	REPLACE ALUM SIGNS SF		
							POST TYPE	POSTS	ANCHOR TYPE	MOUNTING DESIGNATION		TY = TYPE	TYPE A	TYPE G
							FRP = Fiberglass TWT = Thin-Wall 10BWG = 10 BWG S80 = Sch 80	1 or 2	UA=Universal Conc UB=Universal Bolt SA=Slipbase-Conc SB=Slipbase-Bolt WS=Wedge Steel WP=Wedge Plastic	PREFABRICATED 1EXT or 2EXT = # of Ext BM = Extruded Wind Beam WC = 1.12 #/ft Wing Channel EXAL= Extruded Alum Sign Panels		TY N TY S		
112	1	D10-1		12 X 24	X		INSTALL	ON EXISTING MOUNT				2.0		
112	2	D1-2		84 X 30	X		INSTALL	ON EXISTING MOUNT				17.5		
112	3	D1-2		84 X 30	X		INSTALL	ON EXISTING MOUNT				17.5		
112	4	E5-1c		60 X 90	X		INSTALL	ON EXISTING MOUNT					37.5	
112	9	E5-1c		60 X 90	X		INSTALL	ON EXISTING MOUNT					37.5	
112	10	E5-1c		60 X 90	X		INSTALL	ON EXISTING MOUNT					37.5	
112	13	D10-1		12 X 24	X		INSTALL	ON EXISTING MOUNT				2.0		
114	1	D10-1		12 X 24	X		INSTALL	ON EXISTING MOUNT				2.0		
114	2	D23-1T		48 X 24	X		INSTALL	ON EXISTING MOUNT				8.0		
114	3	E5-1c		60 X 90	X		INSTALL	ON EXISTING MOUNT					37.5	

ALUMINUM SIGN BLANKS THICKNESS	
Square Feet	Minimum Thickness
Less than 7.5	0.080"
7.5 to 15	0.100"
Greater than 15	0.125"

The Standard Highway Sign Designs for Texas (SHSD) can be found at the following website.
<http://www.txdot.gov/>

- NOTE:**
- Sign supports shall be located as shown on the plans, except that the Engineer may shift the sign supports, within design guidelines, where necessary to secure a more desirable location or to avoid conflict with utilities. Unless otherwise shown on the plans, the Contractor shall stake and the Engineer will verify all sign support locations.
 - For installation of bridge mount clearance signs, see Bridge Mounted Clearance Sign Assembly (BMCS) Standard Sheet.
 - For Sign Support Descriptive Codes, see Sign Mounting Details Small Roadside Signs General Notes & Details SMD(GEN).

SHEET 32 OF 35



SUMMARY OF SMALL SIGNS

SOSS

FILE: slums16.dgn	DN: TxDOT	CK: TxDOT	DW: TxDOT	CR: TxDOT
© TxDOT May 1987	CONT	SECT	JOB	HIGHWAY
REVISIONS	0095	14	033, ETC	IH 20
4-16	DIST	COUNTY	SHEET NO.	
8-16	DAL	VARIOUS	74	

SUMMARY OF SMALL SIGNS

DATE: 3/20/2023 3:25:00 PM
 FILE: T:\DAL\TRAFFIC\2023 PS&E\IH 20\Signing\IH 20 SOSS.dgn
 PS&E\IH 20\Signing Set\IH 20\Signing Set\IH 20 SOSS.dgn
 The use of this standard is governed by the "Texas Engineering Practice Act". No warranty of any kind is made by TxDOT for any purpose whatsoever. TxDOT assumes no responsibility for the conversion of this standard to other formats or for incorrect results or damages resulting from its use.

PLAN SHEET NO.	SIGN NO.	SIGN NOMENCLATURE	SIGN	DIMENSIONS	FLAT ALUMINUM (TYPE A)	EXAL ALUMINUM (TYPE G)	SM RD SGN ASSM TY XXXXX (X) XX (X-XXXX)				BRIDGE MOUNT CLEARANCE SIGNS (See Note 2)	REPLACE ALUM SIGNS SF		
							POST TYPE	POSTS	ANCHOR TYPE	MOUNTING DESIGNATION		TY = TYPE	TYPE A	TYPE G
							FRP = Fiberglass TWT = Thin-Wall 10BWG = 10 BWG S80 = Sch 80	1 or 2	UA=Universal Conc UB=Universal Bolt SA=Slipbase-Conc SB=Slipbase-Bolt WS=Wedge Steel WP=Wedge Plastic	PREFABRICATED P = "Plain" T = "T" U = "U"				
			IH 635 (CSJ: 2374-02-157)											
114	5	E5-1c		60 X 90	X		INSTALL	ON EXISTING MOUNT				37.5		
114	6	D10-1		12 X 24	X		INSTALL	ON EXISTING MOUNT			2.0			
116	1	D10-1		12 X 24	X		INSTALL	ON EXISTING MOUNT			2.0			
116	2	E5-1c		60 X 90	X		INSTALL	ON EXISTING MOUNT				37.5		
116	4	D10-1		12 X 24	X		INSTALL	ON EXISTING MOUNT			2.0			
116	5	E5-1c		60 X 90	X		INSTALL	ON EXISTING MOUNT				37.5		
117	1	I-2aT		96 X 24	X		INSTALL	ON EXISTING MOUNT				16.0		
117	4	D10-1		12 X 24	X		INSTALL	ON EXISTING MOUNT			2.0			
117	5	GREEN		126" X 54"	X		INSTALL	ON EXISTING MOUNT				47.25		
117	6	I-2aT		66 X 24	X		10BWG	1	SA	T				
117	10	E5-1c		60 X 90	X		INSTALL	ON EXISTING MOUNT				37.5		

ALUMINUM SIGN BLANKS THICKNESS	
Square Feet	Minimum Thickness
Less than 7.5	0.080"
7.5 to 15	0.100"
Greater than 15	0.125"

The Standard Highway Sign Designs for Texas (SHSD) can be found at the following website:
<http://www.txdot.gov/>

- NOTE:**
- Sign supports shall be located as shown on the plans, except that the Engineer may shift the sign supports, within design guidelines, where necessary to secure a more desirable location or to avoid conflict with utilities. Unless otherwise shown on the plans, the Contractor shall stake and the Engineer will verify all sign support locations.
 - For installation of bridge mount clearance signs, see Bridge Mounted Clearance Sign Assembly (BMCS) Standard Sheet.
 - For Sign Support Descriptive Codes, see Sign Mounting Details Small Roadside Signs General Notes & Details SMD(GEN).

SHEET 33 OF 35



SUMMARY OF SMALL SIGNS

SOSS

FILE: slums16.dgn	DN: TxDOT	CK: TxDOT	DW: TxDOT	CK: TxDOT
© TxDOT May 1987	CONT	SECT	JOB	HIGHWAY
REVISIONS	0095	14	033, ETC	IH 20
4-16	DIST	COUNTY	SHEET NO.	
8-16	DAL	VARIOUS	75	

SUMMARY OF SMALL SIGNS

DATE: 3/20/2023 3:25:02 PM
 FILE: T:\DAL\TRAFFIC\2023 PS&E\IH 20 Signing\IH 20 Soss.dgn
 The use of this standard is governed by the "Texas Engineering Practice Act". No warranty of any kind is made by TxDOT for any purpose whatsoever. TxDOT assumes no responsibility for the conversion of this standard to other formats or for incorrect results or damages resulting from its use.

PLAN SHEET NO.	SIGN NO.	SIGN NOMENCLATURE	SIGN	DIMENSIONS	FLAT ALUMINUM (TYPE A)	EXAL ALUMINUM (TYPE G)	SM RD SGN ASSM TY XXXXX (X) XX (X-XXXX)				BRIDGE MOUNT CLEARANCE SIGNS (See Note 2)	REPLACE ALUM SIGNS SF		
							POST TYPE	POSTS	ANCHOR TYPE	MOUNTING DESIGNATION		TY = TYPE	TYPE A	TYPE G
							FRP = Fiberglass TWT = Thin-Wall 10BWG = 10 BWG S80 = Sch 80	1 or 2	UA=Universal Conc UB=Universal Bolt SA=Slipbase-Conc SB=Slipbase-Bolt WS=Wedge Steel WP=Wedge Plastic	PREFABRICATED P = "Plain" T = "T" U = "U"				
			IH 635 (CSJ: 2374-02-157)											
117	11	D10-1	MILE 3	12 X 24	X		INSTALL	ON EXISTING MOUNT				2.0		
118	1	D3-1G	Bruton Rd	72 X 18	X		INSTALL	ON EXISTING MOUNT		N		9.0		
118	2	D1-2	← W Cartwright Rd Bruton Rd →	126 X 30	X		INSTALL	ON EXISTING MOUNT				26.25		
118	4	E5-1c	EXIT 3 ↗	60 X 90	X		INSTALL	ON EXISTING MOUNT				37.5		
118	5	D1-2	← Bruton Rd W Cartwright Rd →	126 X 30	X		INSTALL	ON EXISTING MOUNT				26.25		
118	6	D3-1G	Bruton Rd	72 X 18	X		INSTALL	ON EXISTING MOUNT		N		9.0		
119	1	D3-1G	New Market Rd	102 X 18	X		INSTALL	ON EXISTING MOUNT		N		12.75		
119	3	D10-1	MILE 4	12 X 24	X		INSTALL	ON EXISTING MOUNT				2.0		
119	4	D3-1G	New Market Rd	102 X 18	X		INSTALL	ON EXISTING MOUNT		N		12.75		
119	6	D10-1	MILE 4	12 X 24	X		INSTALL	ON EXISTING MOUNT				2.0		
120	1	D1-2	↑ Mesquite Arena ↑ Convention Ctr	120 X 30	X		INSTALL	ON EXISTING MOUNT				25.0		
120	5	E5-1c	EXIT 4 ↗	60 X 90	X		INSTALL	ON EXISTING MOUNT				37.5		
120	6	D1-3	↑ Military Pkwy WEST ↑ Scyene Rd Military Pkwy EAST →	144 X 42	X		INSTALL	ON EXISTING MOUNT				42.0		

ALUMINUM SIGN BLANKS THICKNESS	
Square Feet	Minimum Thickness
Less than 7.5	0.080"
7.5 to 15	0.100"
Greater than 15	0.125"

The Standard Highway Sign Designs for Texas (SHSD) can be found at the following website.
<http://www.txdot.gov/>

- NOTE:**
- Sign supports shall be located as shown on the plans, except that the Engineer may shift the sign supports, within design guidelines, where necessary to secure a more desirable location or to avoid conflict with utilities. Unless otherwise shown on the plans, the Contractor shall stake and the Engineer will verify all sign support locations.
 - For installation of bridge mount clearance signs, see Bridge Mounted Clearance Sign Assembly (BMCS) Standard Sheet.
 - For Sign Support Descriptive Codes, see Sign Mounting Details Small Roadside Signs General Notes & Details SMD(GEN).

SHEET 34 OF 35



SUMMARY OF SMALL SIGNS

SOSS

FILE: slums16.dgn	DN: TxDOT	CK: TxDOT	DW: TxDOT	CR: TxDOT
© TxDOT May 1987	CONT	SECT	JOB	HIGHWAY
REVISIONS	0095 14	033, ETC	IH 20	
4-16	DIST	COUNTY	SHEET NO.	
8-16	DAL	VARIOUS	76	

SUMMARY OF SMALL SIGNS

DATE: 3/20/2023 3:25:04 PM
 FILE: T:\DAL\TRAFFIC\2023 PS&E\IH 20\Signing\IH 20_SOSS.dgn
 DISCLAIMER: The use of this standard is governed by the "Texas Engineering Practice Act". No warranty of any kind is made by TxDOT for any purpose whatsoever. TxDOT assumes no responsibility for the conversion of this standard to other formats or for incorrect results or damages resulting from its use.

PLAN SHEET NO.	SIGN NO.	SIGN NOMENCLATURE	SIGN	DIMENSIONS	FLAT ALUMINUM (TYPE A)	EXAL ALUMINUM (TYPE G)	SM RD SGN ASSM TY XXXXX (X) XX (X-XXXX)				BRIDGE MOUNT CLEARANCE SIGNS (See Note 2)	REPLACE ALUM SIGNS SF		
							POST TYPE	POSTS	ANCHOR TYPE	MOUNTING DESIGNATION		TY = TYPE	TYPE A	TYPE G
							FRP = Fiberglass TWT = Thin-Wall 10BWG = 10 BWG S80 = Sch 80	1 or 2	UA=Universal Conc UB=Universal Bolt SA=Slipbase-Conc SB=Slipbase-Bolt WS=Wedge Steel WP=Wedge Plastic	PREFABRICATED 1EXT or 2EXT = # of Ext BM = Extruded Wind Beam WC = 1.12 #/ft Wing Channel EXAL= Extruded Alum Sign Panels		TY N TY S		
			IH 635 (CSJ: 2374-02-157)											
120	7	D1-2	Mesquite Arena Convention Ctr	90 X 24	X		INSTALL	ON EXISTING MOUNT				15.0		
120	8	D23-1T	State Rep Victoria Neave District 107 →	60 X 24	X		INSTALL	ON EXISTING MOUNT				10.0		
121	1	D23-1T	← State Rep Victoria Neave District 107	54 X 24	X		INSTALL	ON EXISTING MOUNT				9.0		
121	2	D1-2	← Mesquite Arena Convention Ctr	90 X 24	X		INSTALL	ON EXISTING MOUNT				15.0		
121	3	D1-2	Mesquite Arena Convention Ctr	90 X 24	X		INSTALL	ON EXISTING MOUNT				15.0		
121	4	D1-3	Military Pkwy EAST Military Pkwy WEST → Scyene Rd →	144 X 42	X		INSTALL	ON EXISTING MOUNT				42.0		
121	5	E5-1c	EXIT 4 	60 X 90	X		INSTALL	ON EXISTING MOUNT				37.5		
121	8	D10-1	MILE 5	12 X 24	X		INSTALL	ON EXISTING MOUNT				2.0		
121	9	D1-2	← Military Pkwy WEST ← Scyene Rd	144 X 30	X		INSTALL	ON EXISTING MOUNT				30.0		
121	10	D1-2	← Mesquite Arena Convention Ctr	90 X 24	X		INSTALL	ON EXISTING MOUNT				15.0		
121	12	D10-1	MILE 5	12 X 24	X		INSTALL	ON EXISTING MOUNT				2.0		

ALUMINUM SIGN BLANKS THICKNESS	
Square Feet	Minimum Thickness
Less than 7.5	0.080"
7.5 to 15	0.100"
Greater than 15	0.125"

The Standard Highway Sign Designs for Texas (SHSD) can be found at the following website.
<http://www.txdot.gov/>

- NOTE:**
- Sign supports shall be located as shown on the plans, except that the Engineer may shift the sign supports, within design guidelines, where necessary to secure a more desirable location or to avoid conflict with utilities. Unless otherwise shown on the plans, the Contractor shall stake and the Engineer will verify all sign support locations.
 - For installation of bridge mount clearance signs, see Bridge Mounted Clearance Sign Assembly (BMCS) Standard Sheet.
 - For Sign Support Descriptive Codes, see Sign Mounting Details Small Roadside Signs General Notes & Details SMD(GEN).

SHEET 35 OF 35



SUMMARY OF SMALL SIGNS

SOSS

FILE: slums16.dgn	DN: TxDOT	CK: TxDOT	DW: TxDOT	CR: TxDOT
© TxDOT May 1987	CONT	SECT	JOB	HIGHWAY
REVISIONS	0095	14	033, ETC	IH 20
4-16	DIST	COUNTY	SHEET NO.	
8-16	DAL	VARIOUS	77	

DATE: 3/17/2023 4:30:03 PM
 FILE: T:\DAL\TRAFM\FY 2023 PS&E\I.H. 20\Plan Set\Standards\non-paf_standards.dwg
 The use of this standard is governed by the "Texas Engineering Practice Act". No warranty of any kind is made by TxDOT or any person who discovers. TxDOT assumes no responsibility for the conversion of this standard to any other format or for incorrect results or damages resulting from its use.
 DISCLAIMER:

BARRICADE AND CONSTRUCTION (BC) STANDARD SHEETS GENERAL NOTES:

- The Barricade and Construction Standard Sheets (BC sheets) are intended to show typical examples for placement of temporary traffic control devices, construction pavement markings, and typical work zone signs. The information contained in these sheets meet or exceed the requirements shown in the "Texas Manual on Uniform Traffic Control Devices" (TMUTCD).
- The development and design of the Traffic Control Plan (TCP) is the responsibility of the Engineer.
- The Contractor may propose changes to the TCP that are signed and sealed by a licensed professional engineer for approval. The Engineer may develop, sign and seal Contractor proposed changes.
- The Contractor is responsible for installing and maintaining the traffic control devices as shown in the plans. The Contractor may not move or change the approximate location of any device without the approval of the Engineer.
- Geometric design of lane shifts and detours should, when possible, meet the applicable design criteria contained in manuals such as the American Association of State Highway and Transportation Officials (AASHTO), "A Policy on Geometric Design of Highways and Streets," the TxDOT "Roadway Design Manual" or engineering judgment.
- When projects abut, the Engineer(s) may omit the END ROAD WORK, TRAFFIC FINES DOUBLE, and other advance warning signs if the signing would be redundant and the work areas appear continuous to the motorists. If the adjacent project is completed first, the Contractor shall erect the necessary warning signs as shown on these sheets, the TCP sheets or as directed by the Engineer. The BEGIN ROAD WORK NEXT X MILES sign shall be revised to show appropriate work zone distance.
- The Engineer may require duplicate warning signs on the median side of divided highways where median width will permit and traffic volumes justify the signing.
- All signs shall be constructed in accordance with the details found in the "Standard Highway Sign Designs for Texas," latest edition. Sign details not shown in this manual shall be shown in the plans or the Engineer shall provide a detail to the Contractor before the sign is manufactured.
- The temporary traffic control devices shown in the illustrations of the BC sheets are examples. As necessary, the Engineer will determine the most appropriate traffic control devices to be used.
- Where highway construction or maintenance work is being undertaken, other than mobile operations as defined by the Texas Manual on Uniform Traffic Control Devices, CSJ limit signs are required. CSJ limit signs are shown on BC(2). The OBEY WARNING SIGNS STATE LAW sign, STAY ALERT TALK OR TEXT LATER and the WORK ZONE TRAFFIC FINES DOUBLE sign with plaque shall be erected in advance of the CSJ limits. The BEGIN ROAD WORK NEXT X MILES, CONTRACTOR and END ROAD WORK signs shall be erected at or near the CSJ limits. For mobile operations, CSJ limit signs are not required.
- Traffic control devices should be in place only while work is actually in progress or a definite need exists.
- The Engineer has the final decision on the location of all traffic control devices.
- Inactive equipment and work vehicles, including workers' private vehicles must be parked away from travel lanes. They should be as close to the right-of-way line as possible, or located behind a barrier or guardrail, or as approved by the Engineer.

WORKER SAFETY NOTES:

- Workers on foot who are exposed to traffic or to construction equipment within the right-of-way shall wear high-visibility safety apparel meeting the requirements of ISEA "American National Standard for High-Visibility Apparel," or equivalent revisions, and labeled as ANSI 107-2004 standard performance for Class 2 or 3 risk exposure. Class 3 garments should be considered for high traffic volume work areas or night time work.
- Except in emergency situations, flagger stations shall be illuminated when flagging is used at night.

COMPLIANT WORKZONE TRAFFIC CONTROL DEVICES

- Only pre-qualified products shall be used. The "Compliant Work Zone Traffic Control Devices List" (CWZTCD) describes pre-qualified products and their sources.
- Work zone traffic control devices shall be compliant with the Manual for Assessing safety Hardware (MASH).

THE DOCUMENTS BELOW CAN BE FOUND ON-LINE AT http://www.txdot.gov
COMPLIANT WORK ZONE TRAFFIC CONTROL DEVICES LIST (CWZTCD)
DEPARTMENTAL MATERIAL SPECIFICATIONS (DMS)
MATERIAL PRODUCER LIST (MPL)
ROADWAY DESIGN MANUAL - SEE "MANUALS (ONLINE MANUALS)"
STANDARD HIGHWAY SIGN DESIGNS FOR TEXAS (SHSD)
TEXAS MANUAL ON UNIFORM TRAFFIC CONTROL DEVICES (TMUTCD)
TRAFFIC ENGINEERING STANDARD SHEETS

SHEET 1 OF 12

 Texas Department of Transportation		Traffic Safety Division Standard	
BARRICADE AND CONSTRUCTION GENERAL NOTES AND REQUIREMENTS			
BC (1) - 21			
FILE:	bc-21.dgn	DN:	TxDOT
© TxDOT	November 2002	CK:	TxDOT
		DW:	TxDOT
		CK:	TxDOT
REVISIONS	CONT	SECT	JOB
4-03 7-13	0095	14	033, ETC
9-07 8-14			IH 20, ETC
5-10 5-21	DIST	COUNTY	SHEET NO.
	DAL	KAUFMAN, ETC	78

DATE: 3/17/2023 4:30:04 PM
 FILE: T:\DAL\TRAFFIC\2023 PS&E\1H 20\Plan Set\Standards\non-paf_standards.dwg
 The use of this standard is governed by the "Texas Engineering Practice Act". No warranty of any kind is made by TxDOT for any purpose whatsoever. TxDOT assumes no responsibility for incorrect results or damages resulting from its use.

TYPICAL LOCATION OF CROSSROAD SIGNS

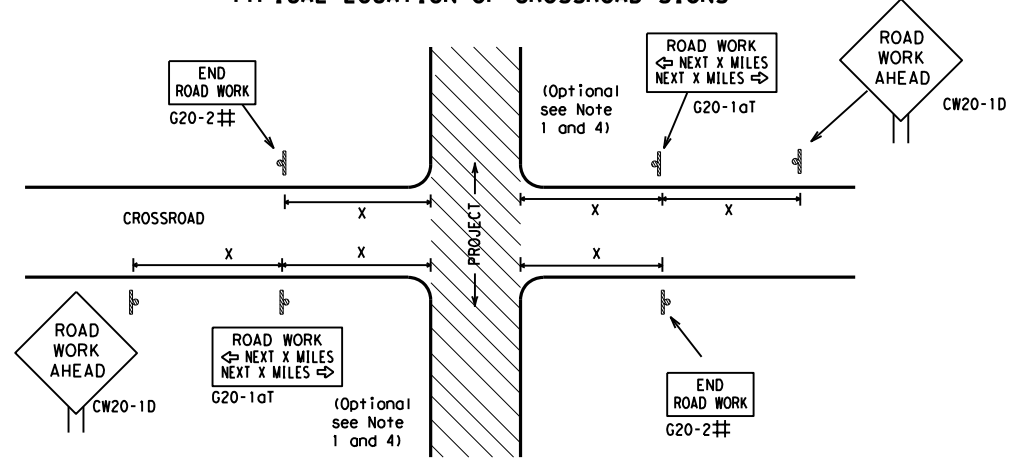

May be mounted on back of "ROAD WORK AHEAD" (CW20-1D) sign with approval of Engineer. (See note 2 below)

1. The typical minimum signing on a crossroad approach should be a "ROAD WORK AHEAD" (CW20-1D) sign and a (G20-2) "END ROAD WORK" sign, unless noted otherwise in plans.
2. The Engineer may use the reduced size 36" x 36" ROAD WORK AHEAD (CW20-1D) sign mounted back to back with the reduced size 36" x 18" "END ROAD WORK" (G20-2) sign on low volume crossroads (see Note 4 under "Typical Construction Warning Sign Size and Spacing"). See the "Standard Highway Sign Designs for Texas" manual for sign details. The Engineer may omit the advance warning signs on low volume crossroads. The Engineer will determine whether a road is low volume as per TMUTCD Part 5. This information shall be shown in the plans.
3. Based on existing field conditions, the Engineer/Inspector may require additional signs such as FLAGGER AHEAD, LOOSE GRAVEL, or other appropriate signs. When additional signs are required, these signs will be considered part of the minimum requirements. The Engineer/Inspector will determine the proper location and spacing of any sign not shown on the BC sheets, Traffic Control Plan sheets or the Work Zone Standard Sheets.
4. The "ROAD WORK NEXT X MILES" (G20-1aT) sign shall be required at high volume crossroads to advise motorists of the length of construction in either direction from the intersection. The Engineer will determine whether a roadway is considered high volume.
5. Additional traffic control devices may be shown elsewhere in the plans for higher volume crossroads.
6. When work occurs in the intersection area, appropriate traffic control devices, as shown elsewhere in the plans or as determined by the Engineer/Inspector, shall be in place.

T-INTERSECTION

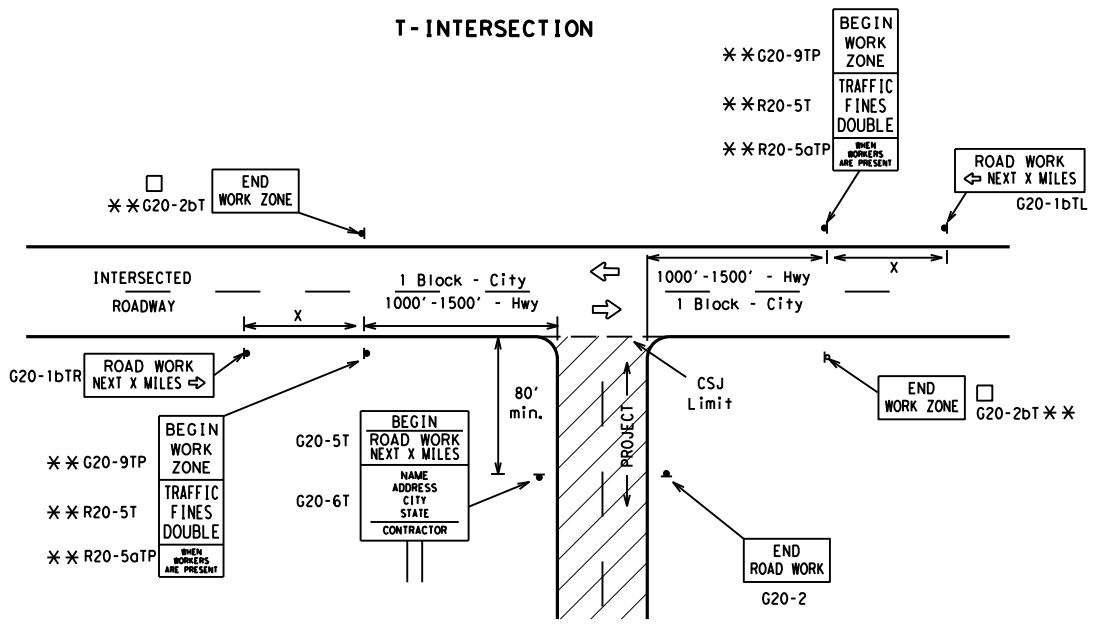

CSJ LIMITS AT T-INTERSECTION

1. The Engineer will determine the types and location of any additional traffic control devices, such as a flagger and accompanying signs, or other signs, that should be used when work is being performed at or near an intersection.
2. If construction closes the road at a T-intersection, the Contractor shall place the "CONTRACTOR NAME" (G20-6T) sign behind the Type 3 Barricades for the road closure (see BC(10) also). The "ROAD WORK NEXT X MILES" left arrow (G20-1bTL) and "ROAD WORK NEXT X MILES" right arrow (G20-1bTR) signs shall be replaced by the detour signing called for in the plans.

TYPICAL CONSTRUCTION WARNING SIGN SIZE AND SPACING^{1,5,6}

Sign Number or Series	SIZE		SPACING	
	Conventional Road	Expressway/Freeway	Posted Speed MPH	Sign Δ Spacing "x" Feet (Apprx.)
CW20 ⁴	48" x 48"	48" x 48"	30	120
CW21			35	160
CW22			40	240
CW23			45	320
CW25			50	400
CW1, CW2, CW7, CW8, CW9, CW11, CW14	36" x 36"	48" x 48"	55	500 ²
CW3, CW4, CW5, CW6, CW8-3, CW10, CW12	48" x 48"	48" x 48"	60	600 ²
			65	700 ²
			70	800 ²
			75	900 ²
			80	1000 ²
			*	* ³

* For typical sign spacings on divided highways, expressways and freeways, see Part 6 of the "Texas Manual on Uniform Traffic Control Devices" (TMUTCD) typical application diagrams or TCP Standard Sheets.

Δ Minimum distance from work area to first Advance Warning sign nearest the work area and/or distance between each additional sign.

GENERAL NOTES

1. Special or larger size signs may be used as necessary.
2. Distance between signs should be increased as required to have 1500 feet advance warning.
3. Distance between signs should be increased as required to have 1/2 mile or more advance warning.
4. 36" x 36" "ROAD WORK AHEAD" (CW20-1D) signs may be used on low volume crossroads at the discretion of the Engineer as per TMUTCD Part 5. See Note 2 under "Typical Location of Crossroad Signs".
5. Only diamond shaped warning sign sizes are indicated.
6. See sign size listing in "TMUTCD", Sign Appendix or the "Standard Highway Sign Designs for Texas" manual for complete list of available sign design sizes.

WORK AREAS IN MULTIPLE LOCATIONS WITHIN CSJ LIMITS

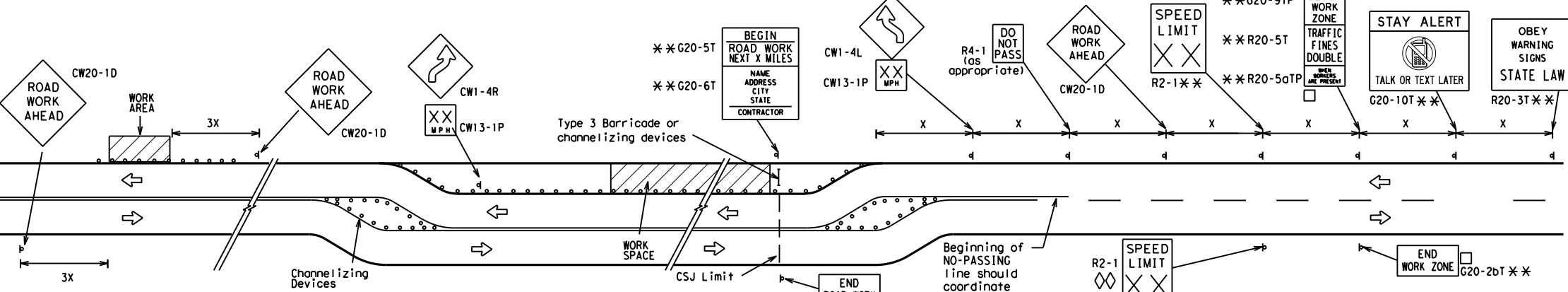

When extended distances occur between minimal work spaces, the Engineer/Inspector should ensure additional "ROAD WORK AHEAD" (CW20-1D) signs are placed in advance of these work areas to remind drivers they are still within the project limits. See the applicable TCP sheets for exact location and spacing of signs and channelizing devices.

SAMPLE LAYOUT OF SIGNING FOR WORK BEGINNING DOWNSTREAM OF THE CSJ LIMITS

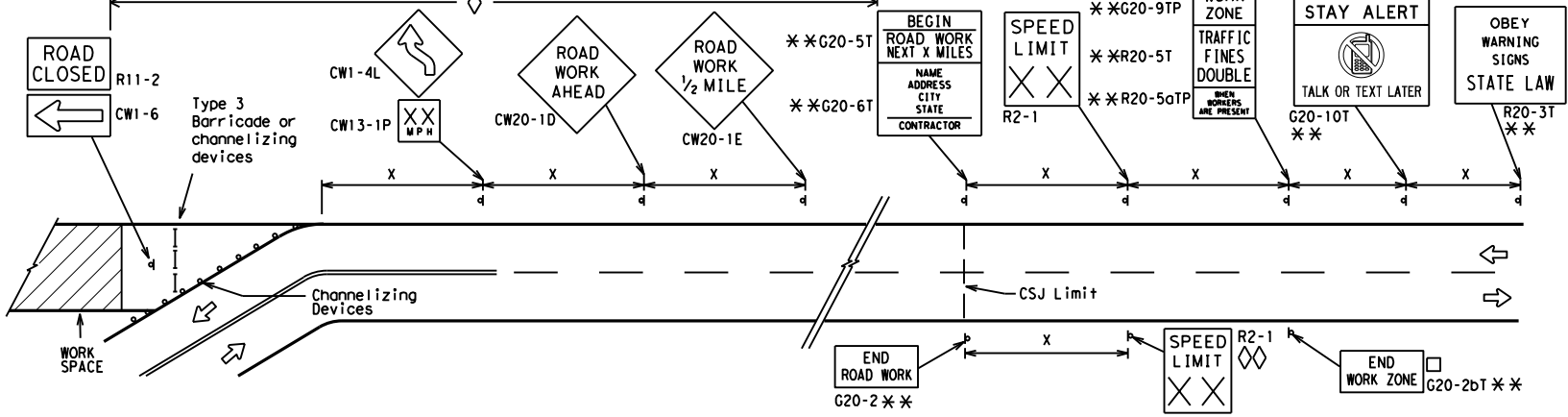

SAMPLE LAYOUT OF SIGNING FOR WORK BEGINNING AT THE CSJ LIMITS

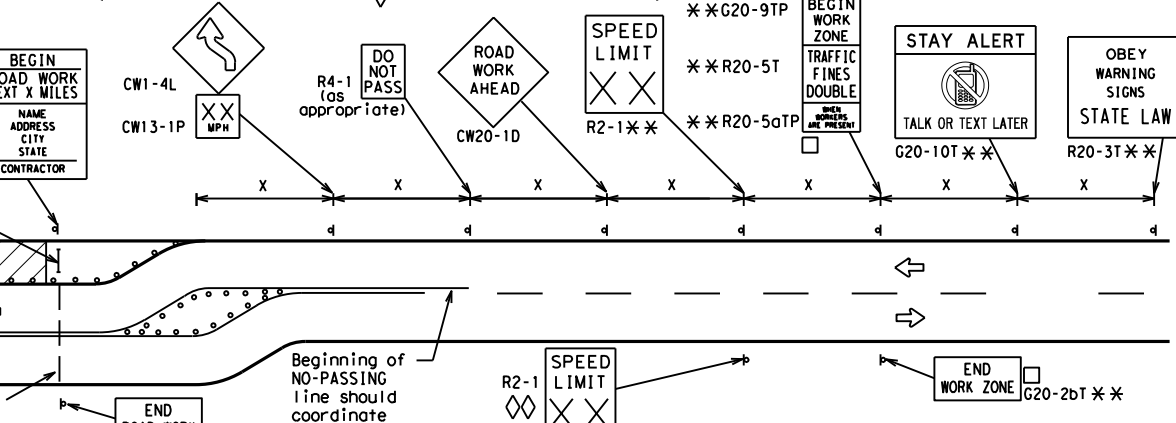

NOTES

- The Contractor shall determine the appropriate distance to be placed on the G20-1 series signs and "BEGIN ROAD WORK NEXT X MILES" (G20-5T) sign for each specific project. This distance shall replace the "x" and shall be rounded to the nearest whole mile with the approval of the Engineer. No decimals shall be used.
- The "BEGIN WORK ZONE" (G20-9TP) and "END WORK ZONE" (G20-2bT) shall be used as shown on the sample layout when advance signs are required outside the CSJ Limits. They inform the motorist of entering or leaving a part of the work zone lying outside the CSJ Limits where traffic fines may double if workers are present.
 - ** CSJ limit signing is required for highway construction and maintenance work, with the exception of mobile operations.
 - ◇ Area for placement of "ROAD WORK AHEAD" (CW20-1D) sign and other signs or devices as called for on the Traffic Control Plan.
 - ◇◇ Contractor will install a regulatory speed limit sign at the end of the work zone.

LEGEND

—	Type 3 Barricade
○ ○ ○	Channelizing Devices
■	Sign
X	See Typical Construction Warning Sign Size and Spacing chart or the TMUTCD for sign spacing requirements.

SHEET 2 OF 12



BARRICADE AND CONSTRUCTION PROJECT LIMIT

BC (2) - 21

FILE: bc-21.dgn	DN: TxDOT	CK: TxDOT	DW: TxDOT	CK: TxDOT
© TxDOT November 2002	CONT	SECT	JOB	HIGHWAY
REVISIONS	0095 14		033, ETC	IH 20, ETC
9-07 8-14	DIST	COUNTY		SHEET NO.
7-13 5-21	DAL	KAUFMAN, ETC		79

TYPICAL APPLICATION OF WORK ZONE SPEED LIMIT SIGNS

Work zone speed limits shall be regulatory, established in accordance with the "Procedures for Establishing Speed Zones," and approved by the Texas Transportation Commission, or by City Ordinance when within Incorporated City Limits.

Reduced speeds should only be posted in the vicinity of work activity and not throughout the entire project. Regulatory work zone speed signs (R2-1) shall be removed or covered during periods when they are not needed.



GUIDANCE FOR USE:

LONG/INTERMEDIATE TERM WORK ZONE SPEED LIMITS

This type of work zone speed limit should be included on the design of the traffic control plans when restricted geometrics with a lower design speed are present in the work zone and modification of the geometrics to a higher design speed is not feasible.

Long/Intermediate Term Work Zone Speed Limit signs, when approved as described above, should be posted and visible to the motorist when work activity is present. Work activity may also be defined as a change in the roadway that requires a reduced speed for motorists to safely negotiate the work area, including:

- rough road or damaged pavement surface
- substantial alteration of roadway geometrics (diversions)
- construction detours
- grade
- width
- other conditions readily apparent to the driver

As long as any of these conditions exist, the work zone speed limit signs should remain in place.

SHORT TERM WORK ZONE SPEED LIMITS

This type of work zone speed limit may be included on the design of the traffic control plans when workers or equipment are not behind concrete barrier, when work activity is within 10 feet of the traveled way or actually in the traveled way.

Short Term Work Zone Speed Limit signs should be posted and visible to the motorists only when work activity is present. When work activity is not present, signs shall be removed or covered. (See Removing or Covering on BC(4)).

GENERAL NOTES

- Regulatory work zone speed limits should be used only for sections of construction projects where speed control is of major importance.
- Regulatory work zone speed limit signs shall be placed on supports at a 7 foot minimum mounting height.
- Speed zone signs are illustrated for one direction of travel and are normally posted for each direction of travel.
- Frequency of work zone speed limit signs should be:

40 mph and greater	0.2 to 2 miles
35 mph and less	0.2 to 1 mile
- Regulatory speed limit signs shall have black legend and border on a white reflective background (See "Reflective Sheeting" on BC(4)).
- Fabrication, erection and maintenance of the "ADVANCE SPEED LIMIT" (CW3-5) sign, "WORK ZONE" (G20-5aP) plaque and the "SPEED LIMIT" (R2-1) signs shall not be paid for directly, but shall be considered subsidiary to Item 502.
- Turning signs from view, laying signs over or down will not be allowed, unless as otherwise noted under "REMOVING OR COVERING" on BC(4).
- Techniques that may help reduce traffic speeds include but are not limited to:
 - Law enforcement.
 - Flagger stationed next to sign.
 - Portable changeable message sign (PCMS).
 - Low-power (drone) radar transmitter.
 - Speed monitor trailers or signs.
- Speeds shown on details above are for illustration only. Work Zone Speed Limits should only be posted as approved for each project.
- For more specific guidance concerning the type of work, work zone conditions and factors impacting allowable regulatory construction speed zone reduction see TxDOT form #1204 in the TxDOT e-form system.

DISCLAIMER: The use of this standard is governed by the "Texas Engineering Practice Act". No warranty of any kind is made by TxDOT for any purpose whatsoever. TxDOT assumes no responsibility for incorrect results or damages resulting from its use.

DATE: 3/17/2023 4:30:06 PM
 FILE: T:\DAL\TRAFFIC\2023 PS&E\I\H 20\Plan Set\Standards\non-paf_standards.dwg

SHEET 3 OF 12

		Traffic Safety Division Standard	
<h2>BARRICADE AND CONSTRUCTION WORK ZONE SPEED LIMIT</h2>			
<h3>BC (3) - 21</h3>			
FILE:	bc-21.dgn	DW:	TxDOT
© TxDOT	November 2002	CONT:	SECT:
REVISIONS		0095	14
9-07	8-14	033, ETC	
7-13	5-21	IH 20, ETC	
DIST:	COUNTY:	SHEET NO.	
DAL	KAUFMAN, ETC	80	

DISCLAIMER: The use of this standard is governed by the "Texas Engineering Practice Act". No warranty of any kind is made by TxDOT for any purpose whatsoever. TxDOT assumes no responsibility for the conversion of this standard to other formats or for incorrect results or damages resulting from its use.

DATE: 3/17/2023 4:30:07 PM
 FILE: T:\DAL\TRAFFIC\FY 2023 PS&E\I.H. 20\Plan Set\Standards\non-paf standard.dwg - 089 BC(1) TO (12) - 21.dgn

TYPICAL MINIMUM CLEARANCES FOR LONG TERM AND INTERMEDIATE TERM SIGNS

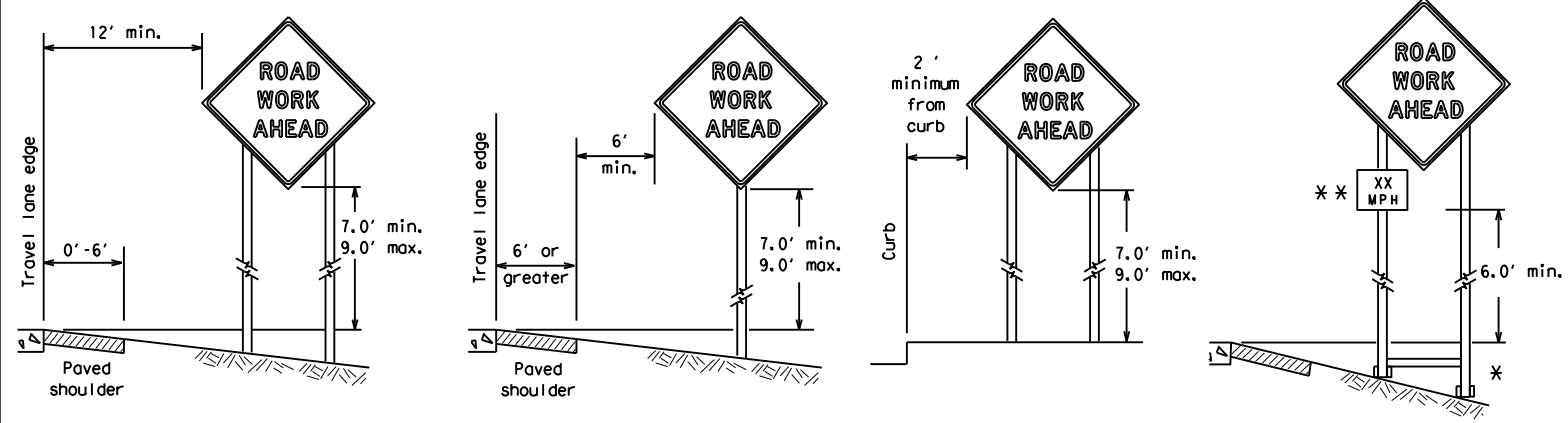

* When placing skid supports on unlevel ground, the leg post lengths must be adjusted so the sign appears straight and plumb. Objects shall NOT be placed under skids as a means of leveling.

** When plaques are placed on dual-leg supports, they should be attached to the upright nearest the travel lane. Supplemental plaques (advisory or distance) should not cover the surface of the parent sign.

ATTACHMENT FOR SIGN SUPPORTS

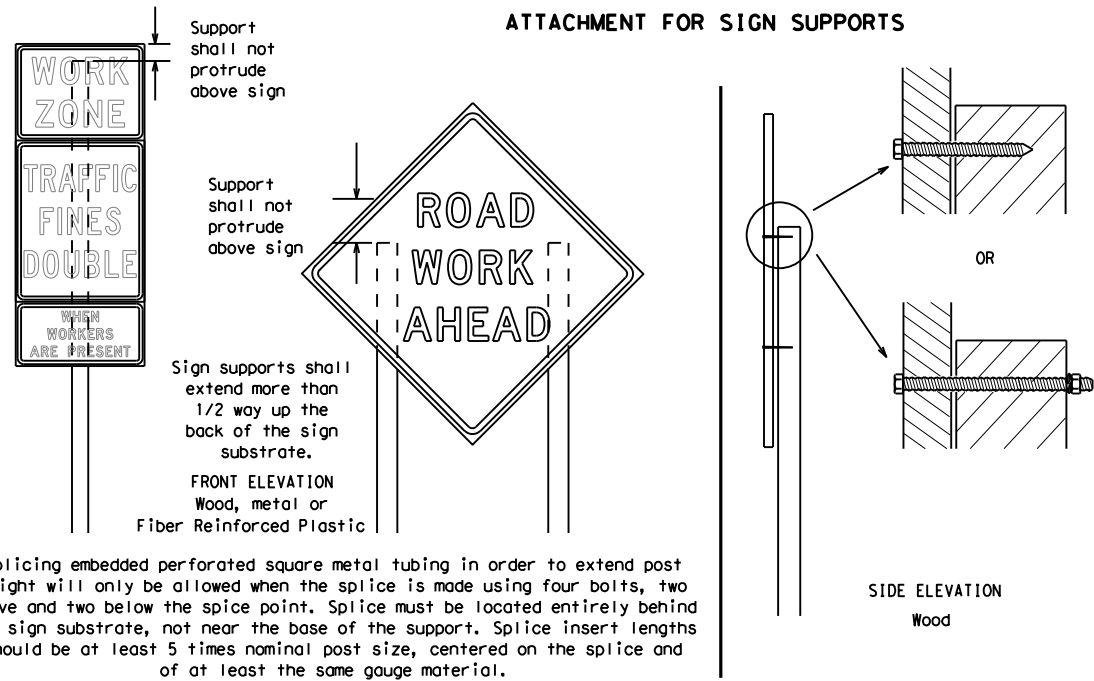

Splicing embedded perforated square metal tubing in order to extend post height will only be allowed when the splice is made using four bolts, two above and two below the splice point. Splice must be located entirely behind the sign substrate, not near the base of the support. Splice insert lengths should be at least 5 times nominal post size, centered on the splice and of at least the same gauge material.

GENERAL NOTES FOR WORK ZONE SIGNS

- Contractor shall install and maintain signs in a straight and plumb condition and/or as directed by the Engineer.
- Wooden sign posts shall be painted white.
- Barricades shall NOT be used as sign supports.
- All signs shall be installed in accordance with the plans or as directed by the Engineer. Signs shall be used to regulate, warn, and guide the traveling public safely through the work zone.
- The Contractor may furnish either the sign design shown in the plans or in the "Standard Highway Sign Designs for Texas" (SHSD). The Engineer/Inspector may require the Contractor to furnish other work zone signs that are shown in the TMUTCD but may have been omitted from the plans. Any variation in the plans shall be documented by written agreement between the Engineer and the Contractor's Responsible Person. All changes must be documented in writing before being implemented. This can include documenting the changes in the Inspector's TxDOT diary and having both the Inspector and Contractor initial and date the agreed upon changes.
- The Contractor shall furnish sign supports listed in the "Compliant Work Zone Traffic Control Device List" (CWZTCD) for small roadside signs. Supports for temporary large roadside signs shall meet the requirements detailed on the Temporary Large Roadside Signs (TLRS) standard sheets. The Contractor shall install the sign support in accordance with the manufacturer's recommendations. If there is a question regarding installation procedures, the Contractor shall furnish the Engineer a copy of the manufacturer's installation recommendations so the Engineer can verify the correct procedures are being followed.
- The Contractor is responsible for installing signs on approved supports and replacing signs with damaged or cracked substrates and/or damaged or marred reflective sheeting as directed by the Engineer/Inspector.
- Identification markings may be shown only on the back of the sign substrate. The maximum height of letters and/or company logos used for identification shall be 1 inch.
- The Contractor shall replace damaged wood posts. New or damaged wood sign posts shall not be spliced.

DURATION OF WORK (as defined by the "Texas Manual on Uniform Traffic Control Devices" Part 6)

- The types of sign supports, sign mounting height, the size of signs, and the type of sign substrates can vary based on the type of work being performed. The Engineer is responsible for selecting the appropriate size sign for the type of work being performed. The Contractor is responsible for ensuring the sign support, sign mounting height and substrate meets manufacturer's recommendations in regard to crashworthiness and duration of work requirements.
 - Long-term stationary - work that occupies a location more than 3 days.
 - Intermediate-term stationary - work that occupies a location more than one daylight period up to 3 days, or nighttime work lasting more than one hour.
 - Short-term stationary - daytime work that occupies a location for more than 1 hour in a single daylight period.
 - Short, duration - work that occupies a location up to 1 hour.
 - Mobile - work that moves continuously or intermittently (stopping for up to approximately 15 minutes.)

SIGN MOUNTING HEIGHT

- The bottom of Long-term/Intermediate-term signs shall be at least 7 feet, but not more than 9 feet, above the paved surface, except as shown for supplemental plaques mounted below other signs.
- The bottom of Short-term/Short Duration signs shall be a minimum of 1 foot above the pavement surface but no more than 2 feet above the ground.
- Long-term/Intermediate-term Signs may be used in lieu of Short-term/Short Duration signing.
- Short-term/Short Duration signs shall be used only during daylight and shall be removed at the end of the workday or raised to appropriate Long-term/Intermediate sign height.
- Regulatory signs shall be mounted at least 7 feet, but not more than 9 feet, above the paved surface regardless of work duration.

SIZE OF SIGNS

- The Contractor shall furnish the sign sizes shown on BC (2) unless otherwise shown in the plans or as directed by the Engineer.

SIGN SUBSTRATES

- The Contractor shall ensure the sign substrate is installed in accordance with the manufacturer's recommendations for the type of sign support that is being used. The CWZTCD lists each substrate that can be used on the different types and models of sign supports.
- "Mesh" type materials are NOT an approved sign substrate, regardless of the tightness of the weave.
- All wooden individual sign panels fabricated from 2 or more pieces shall have one or more plywood cleat, 1/2" thick by 6" wide, fastened to the back of the sign and extending fully across the sign. The cleat shall be attached to the back of the sign using wood screws that do not penetrate the face of the sign panel. The screws shall be placed on both sides of the splice and spaced at 6" centers. The Engineer may approve other methods of splicing the sign face.

REFLECTIVE SHEETING

- All signs shall be retroreflective and constructed of sheeting meeting the color and retro-reflectivity requirements of DMS-8300 for rigid signs or DMS-8310 for roll-up signs. The web address for DMS specifications is shown on BC(1).
- White sheeting, meeting the requirements of DMS-8300 Type A, shall be used for signs with a white background.
- Orange sheeting, meeting the requirements of DMS-8300 Type B_{FL} or Type C_{FL}, shall be used for rigid signs with orange backgrounds.

SIGN LETTERS

- All sign letters and numbers shall be clear, and open rounded type uppercase alphabet letters as approved by the Federal Highway Administration (FHWA) and as published in the "Standard Highway Sign Design for Texas" manual. Signs, letters and numbers shall be of first class workmanship in accordance with Department Standards and Specifications.

REMOVING OR COVERING

- When sign messages may be confusing or do not apply, the signs shall be removed or completely covered.
- Long-term stationary or intermediate stationary signs installed on square metal tubing may be turned away from traffic 90 degrees when the sign message is not applicable. This technique may not be used for signs installed in the median of divided highways or near any intersections where the sign may be seen from approaching traffic.
- Signs installed on wooden skids shall not be turned at 90 degree angles to the roadway. These signs should be removed or completely covered when not required.
- When signs are covered, the material used shall be opaque, such as heavy mil black plastic, or other materials which will cover the entire sign face and maintain their opaque properties under automobile headlights at night, without damaging the sign sheeting.
- Burlap shall NOT be used to cover signs.
- Duct tape or other adhesive material shall NOT be affixed to a sign face.
- Signs and anchor stubs shall be removed and holes backfilled upon completion of work.

SIGN SUPPORT WEIGHTS

- Where sign supports require the use of weights to keep from turning over, the use of sandbags with dry, cohesionless sand should be used.
- The sandbags will be tied shut to keep the sand from spilling and to maintain a constant weight.
- Rock, concrete, iron, steel or other solid objects shall not be permitted for use as sign support weights.
- Sandbags should weigh a minimum of 35 lbs and a maximum of 50 lbs.
- Sandbags shall be made of a durable material that tears upon vehicular impact. Rubber (such as tire inner tubes) shall NOT be used.
- Rubber ballasts designed for channelizing devices should not be used for ballast on portable sign supports. Sign supports designed and manufactured with rubber bases may be used when shown on the CWZTCD list.
- Sandbags shall only be placed along or laid over the base supports of the traffic control device and shall not be suspended above ground level or hung with rope, wire, chains or other fasteners. Sandbags shall be placed along the length of the skids to weigh down the sign support.
- Sandbags shall NOT be placed under the skid and shall not be used to level sign supports placed on slopes.

FLAGS ON SIGNS

- Flags may be used to draw attention to warning signs. When used, the flag shall be 16 inches square or larger and shall be orange or fluorescent red-orange in color. Flags shall not be allowed to cover any portion of the sign face.

STOP/SLOW PADDLES

- STOP/SLOW paddles are the primary method to control traffic by flaggers. The STOP/SLOW paddle size should be 24" x 24".
- STOP/SLOW paddles shall be retroreflective when used at night.
- STOP/SLOW paddles may be attached to a staff with a minimum length of 6' to the bottom of the sign.
- Any lights incorporated into the STOP or SLOW paddle faces shall only be as specifically described in Section 6E.03 Hand Signaling Devices in the TMUTCD.

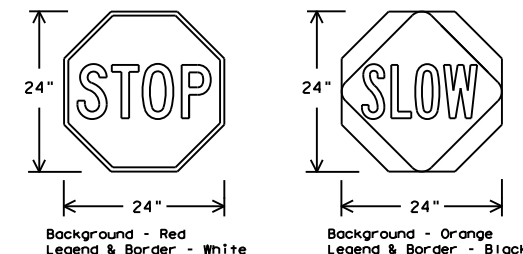

SHEETING REQUIREMENTS (WHEN USED AT NIGHT)		
USAGE	COLOR	SIGN FACE MATERIAL
BACKGROUND	RED	TYPE B OR C SHEETING
BACKGROUND	ORANGE	TYPE B _{FL} OR C _{FL} SHEETING
LEGEND & BORDER	WHITE	TYPE B OR C SHEETING
LEGEND & BORDER	BLACK	ACRYLIC NON-REFLECTIVE FILM

CONTRACTOR REQUIREMENTS FOR MAINTAINING PERMANENT SIGNS WITHIN THE PROJECT LIMITS

- Permanent signs are used to give notice of traffic laws or regulations, call attention to conditions that are potentially hazardous to traffic operations, show route designations, destinations, directions, distances, services, points of interest, and other geographical, recreational, specific service (LOGO), or cultural information. Drivers proceeding through a work zone need the same, if not better route guidance as normally installed on a roadway without construction.
- When permanent regulatory or warning signs conflict with work zone conditions, remove or cover the permanent signs until the permanent sign message matches the roadway condition. For details for covering large guide signs see the TS-CD standard.
- When existing permanent signs are moved and relocated due to construction purposes, they shall be visible to motorists at all times.
- If existing signs are to be relocated on their original supports, they shall be installed on crashworthy bases as shown on the SMD Standard sheets. The signs shall meet the required mounting heights shown on the BC Sheets or the SMD Standards. This work should be paid for under the appropriate pay item for relocating existing signs.
- If permanent signs are to be removed and relocated using temporary supports, the Contractor shall use crashworthy supports as shown on the BC standard sheets, TLRS standard sheets or the CWZTCD list. The signs shall meet the required mounting heights shown on the BC, or the SMD standard sheets during construction. This work should be paid for under the appropriate pay item for relocating existing signs.
- Any sign or traffic control device that is struck or damaged by the Contractor or his/her construction equipment shall be replaced as soon as possible by the Contractor to ensure proper guidance for the motorists. This will be subsidiary to Item 502.



BARRICADE AND CONSTRUCTION TEMPORARY SIGN NOTES

BC (4) - 21

FILE:	bc-21.dgn	DN:	TxDOT	CR:	TxDOT	OW:	TxDOT	CK:	TxDOT
© TxDOT	November 2002	CONT	SECT	JOB	HIGHWAY				
REVISIONS		0095	14	033, ETC		IH 20, ETC			
9-07	8-14	DIST	COUNTY		SHEET NO.				
7-13	5-21	DAL	KAUFMAN, ETC		81				

DATE: 3/17/2023 4:30:09 PM
 FILE: T:\DAL\TRAFFIC\2023 PS&E\I.H. 20\Plan Set\standards\non-paf_standards.dwg
 The use of this standard is governed by the "Texas Engineering Practice Act". No warranty of any kind is made by TxDOT for any purpose whatsoever. TxDOT assumes no responsibility for the conversion of this standard to other formats or for incorrect results or damages resulting from its use.

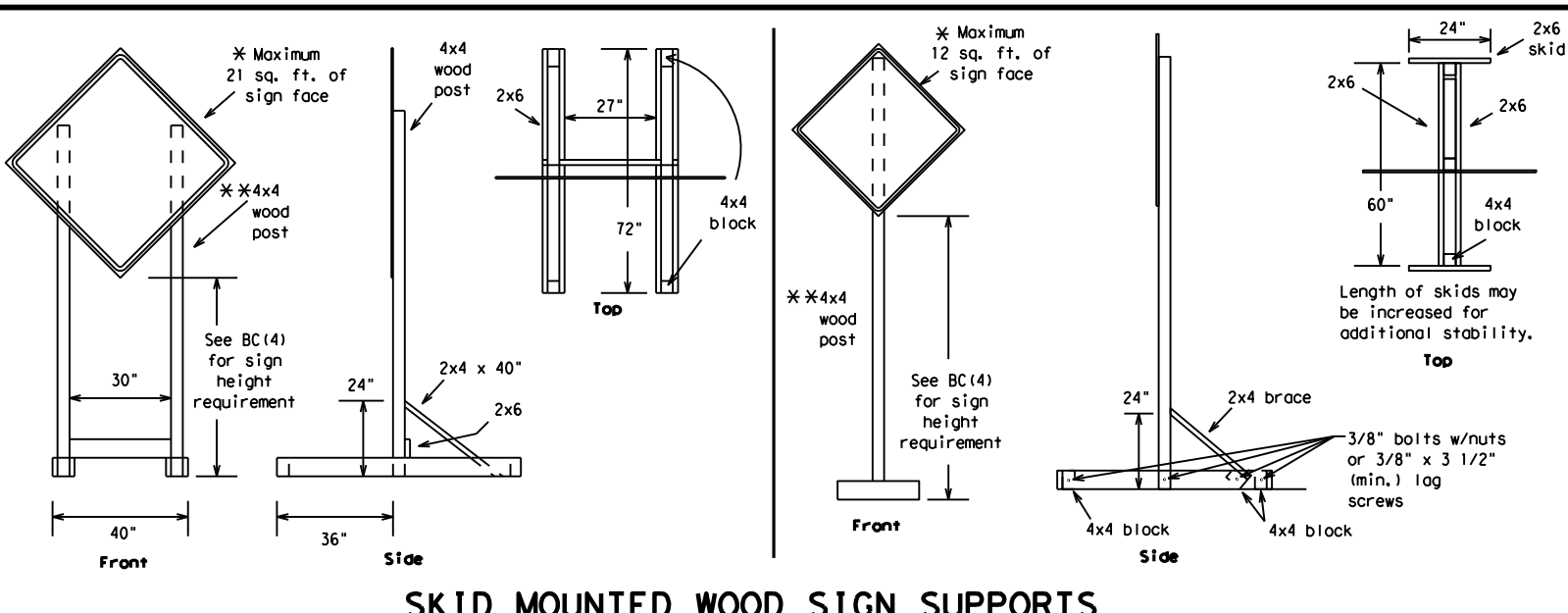

SKID MOUNTED WOOD SIGN SUPPORTS

* LONG/INTERMEDIATE TERM STATIONARY - PORTABLE SKID MOUNTED SIGN SUPPORTS

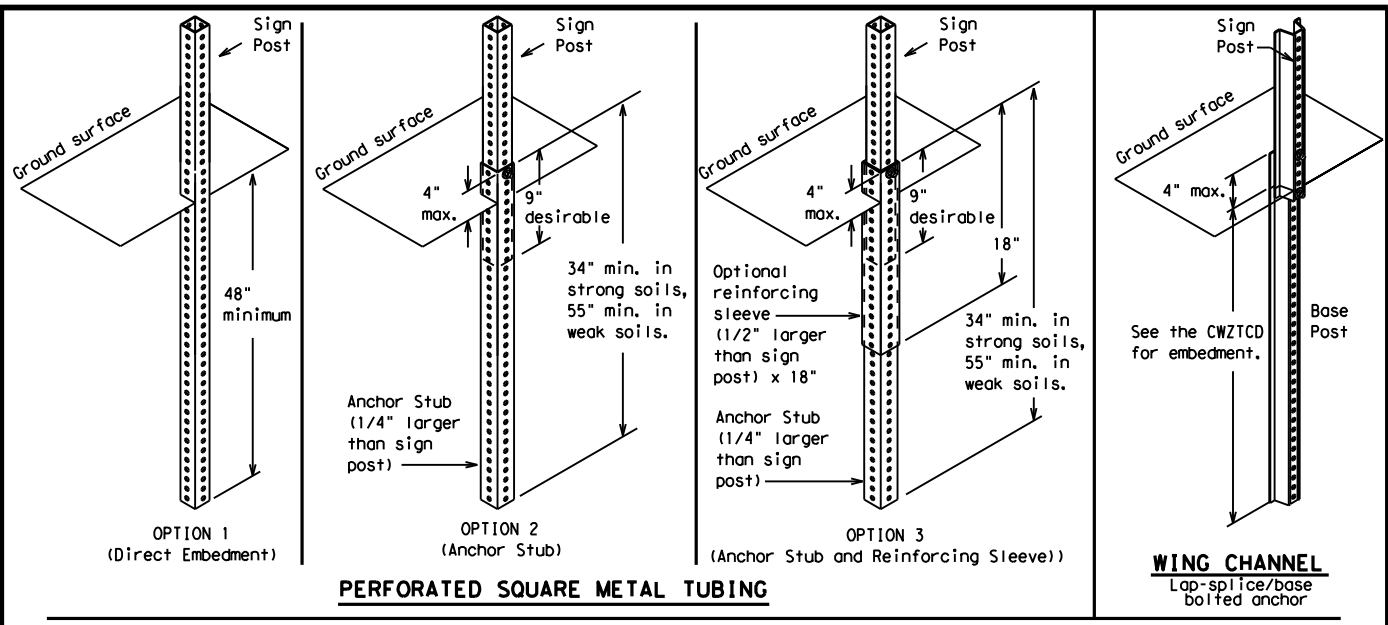

GROUND MOUNTED SIGN SUPPORTS

Refer to the CWZTCD and the manufacturer's installation procedure for each type sign support. The maximum sign square footage shall adhere to the manufacturer's recommendation. Two post installations can be used for larger signs.

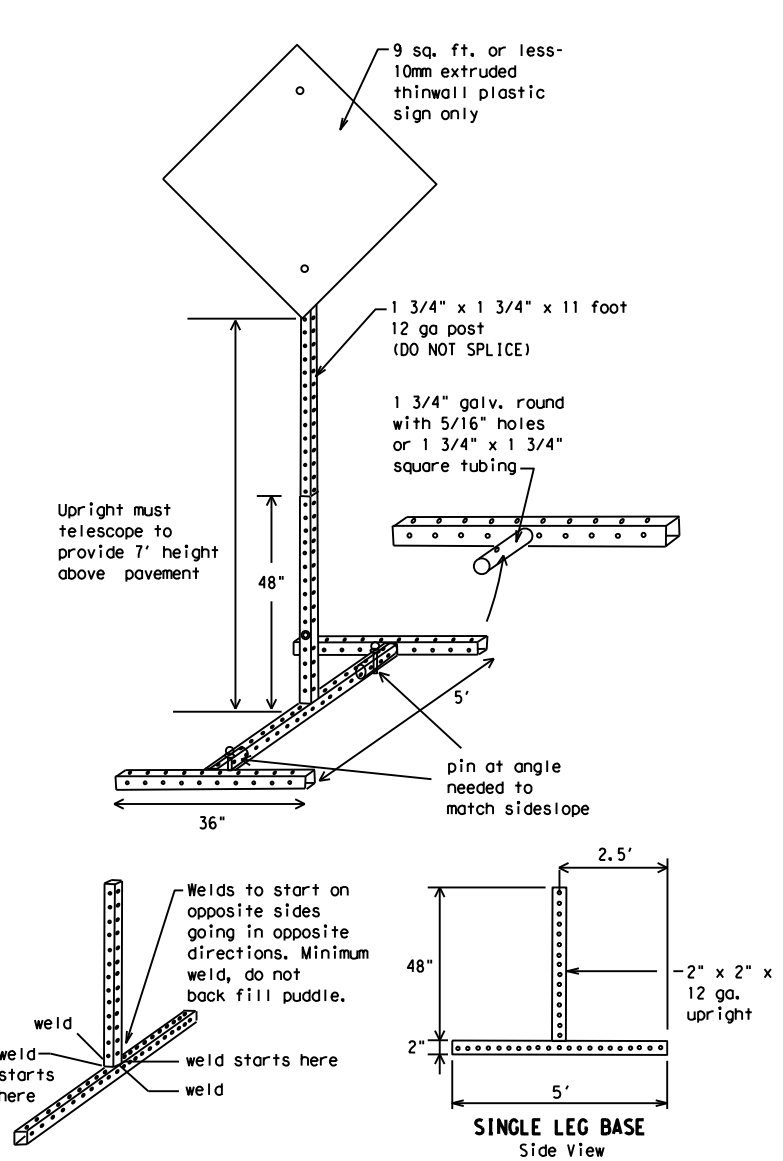

SKID MOUNTED PERFORATED SQUARE STEEL TUBING SIGN SUPPORTS

* LONG/INTERMEDIATE TERM STATIONARY - PORTABLE SKID MOUNTED SIGN SUPPORTS

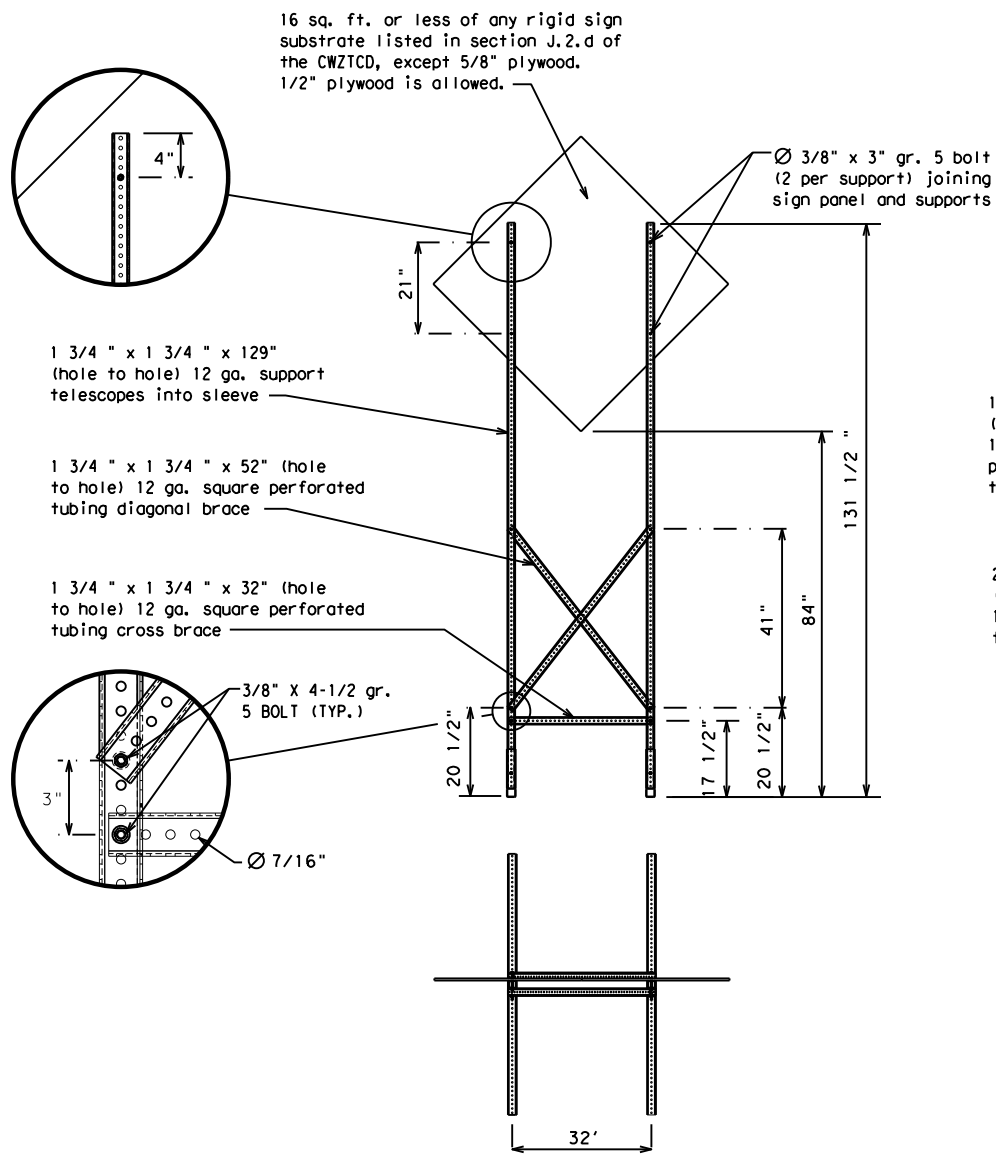

WEDGE ANCHORS

Both steel and plastic Wedge Anchor Systems as shown on the SMD Standard Sheets may be used as temporary sign supports for signs up to 10 square feet of sign face. They may be set in concrete or in sturdy soils if approved by the Engineer. (See web address for "Traffic Engineering Standard Sheets" on BC(1)).

OTHER DESIGNS

MORE DETAILS OF APPROVED LONG/INTERMEDIATE AND SHORT TERM SUPPORTS CAN BE FOUND ON THE CWZTCD LIST. SEE BC(1) FOR WEBSITE LOCATION.

GENERAL NOTES

- Nails may be used in the assembly of wooden sign supports, but 3/8" bolts with nuts or 3/8" x 3 1/2" lag screws must be used on every joint for final connection.
- No more than 2 sign posts shall be placed within a 7 ft. circle, except for specific materials noted on the CWZTCD List.
- When project is completed, all sign supports and foundations shall be removed from the project site. This will be considered subsidiary to Item 502.

- * See BC(4) for definition of "Work Duration."
- ** Wood sign posts MUST be one piece. Splicing will NOT be allowed. Posts shall be painted white.
- ☐ See the CWZTCD for the type of sign substrate that can be used for each approved sign support.

SHEET 5 OF 12



BARRICADE AND CONSTRUCTION TYPICAL SIGN SUPPORT

BC(5) - 21

FILE:	bc-21.dgn	DN:	TxDOT	CK:	TxDOT	DW:	TxDOT	CR:	TxDOT
© TxDOT	November 2002	CONT	SECT	JOB	HIGHWAY				
REVISIONS	0095	14	033, ETC	IH	20, ETC				
9-07	8-14	DIST	COUNTY	SHEET NO.					
7-13	5-21	DAL	KAUFMAN, ETC	82					

WHEN NOT IN USE, REMOVE THE PCMS FROM THE RIGHT-OF-WAY OR PLACE THE PCMS BEHIND BARRIER OR GUARDRAIL WITH SIGN PANEL TURNED PARALLEL TO TRAFFIC

RECOMMENDED PHASES AND FORMATS FOR PCMS MESSAGES DURING ROADWORK ACTIVITIES

(The Engineer may approve other messages not specifically covered here.)

PORTABLE CHANGEABLE MESSAGE SIGNS

- The Engineer/Inspector shall approve all messages used on portable changeable message signs (PCMS).
- Messages on PCMS should contain no more than 8 words (about four to eight characters per word), not including simple words such as "TO," "FOR," "AT," etc.
- Messages should consist of a single phase, or two phases that alternate. Three-phase messages are not allowed. Each phase of the message should convey a single thought, and must be understood by itself.
- Use the word "EXIT" to refer to an exit ramp on a freeway; i.e., "EXIT CLOSED." Do not use the term "RAMP."
- Always use the route or interstate designation (IH, US, SH, FM) along with the number when referring to a roadway.
- When in use, the bottom of a stationary PCMS message panel should be a minimum 7 feet above the roadway, where possible.
- The message term "WEEKEND" should be used only if the work is to start on Saturday morning and end by Sunday evening at midnight. Actual days and hours of work should be displayed on the PCMS if work is to begin on Friday evening and/or continue into Monday morning.
- The Engineer/Inspector may select one of two options which are available for displaying a two-phase message on a PCMS. Each phase may be displayed for either four seconds each or for three seconds each.
- Do not "flash" messages or words included in a message. The message should be steady burn or continuous while displayed.
- Do not present redundant information on a two-phase message; i.e., keeping two lines of the message the same and changing the third line.
- Do not use the word "Danger" in message.
- Do not display the message "LANES SHIFT LEFT" or "LANES SHIFT RIGHT" on a PCMS. Drivers do not understand the message.
- Do not display messages that scroll horizontally or vertically across the face of the sign.
- The following table lists abbreviated words and two-word phrases that are acceptable for use on a PCMS. Both words in a phrase must be displayed together. Words or phrases not on this list should not be abbreviated, unless shown in the TMUTCD.
- PCMS character height should be at least 18 inches for trailer mounted units. They should be visible from at least 1/2 (.5) mile and the text should be legible from at least 600 feet at night and 800 feet in daylight. Truck mounted units must have a character height of 10 inches and must be legible from at least 400 feet.
- Each line of text should be centered on the message board rather than left or right justified.
- If disabled, the PCMS should default to an illegible display that will not alarm motorists and will only be used to alert workers that the PCMS has malfunctioned. A pattern such as a series of horizontal solid bars is appropriate.

DISCLAIMER: The use of this standard is governed by the "Texas Engineering Practice Act." No warranty of any kind is made by TxDOT for any purpose whatsoever. TxDOT assumes no responsibility for the conversion of this standard to other formats or for incorrect results or damages resulting from its use.

WORD OR PHRASE	ABBREVIATION	WORD OR PHRASE	ABBREVIATION
Access Road	ACCS RD	Major	MAJ
Alternate	ALT	Miles	MI
Avenue	AVE	Miles Per Hour	MPH
Best Route	BEST RTE	Minor	MNR
Boulevard	BLVD	Monday	MON
Bridge	BRDG	Normal	NORM
Cannot	CANT	North	N
Center	CTR	Northbound	(route) N
Construction Ahead	CONST AHD	Parking	PKING
CROSSING	XING	Road	RD
Detour Route	DETOUR RTE	Right Lane	RT LN
Do Not	DONT	Saturday	SAT
East	E	Service Road	SERV RD
Eastbound	(route) E	Shoulder	SHLDR
Emergency	EMER	Slippery	SLIP
Emergency Vehicle	EMER VEH	South	S
Entrance, Enter	ENT	Southbound	(route) S
Express Lane	EXP LN	Speed	SPD
Expressway	EXPWY	Street	ST
XXXX Feet	XXXX FT	Sunday	SUN
Fog Ahead	FOG AHD	Telephone	PHONE
Freeway	FRWY, FWY	Temporary	TEMP
Freeway Blocked	FWY BLKD	Thursday	THURS
Friday	FRI	To Downtown	TO DWNTN
Hazardous Driving	HAZ DRIVING	Traffic	TRAF
Hazardous Material	HAZMAT	Travelers	TRVLR
High-Occupancy Vehicle	HOV	Tuesday	TUES
Highway	Hwy	Time Minutes	TIME MIN
Hour(s)	HR, HRS	Upper Level	UPR LEVEL
Information	INFO	Vehicles (s)	VEH, VEHS
It Is	ITS	Warning	WARN
Junction	JCT	Wednesday	WED
Left	LFT	Weight Limit	WT LIMIT
Left Lane	LFT LN	West	W
Lane Closed	LN CLOSED	Westbound	(route) W
Lower Level	LWR LEVEL	Wet Pavement	WET PVMT
Maintenance	MAINT	Will Not	WONT

Roadway designation # IH-number, US-number, SH-number, FM-number

Phase 1: Condition Lists

Road/Lane/Ramp Closure List

FREEWAY CLOSED X MILE
ROAD CLOSED AT SH XXX
ROAD CLSD AT FM XXXX
RIGHT X LANES CLOSED
CENTER LANE CLOSED
NIGHT LANE CLOSURES
VARIOUS LANES CLOSED
EXIT CLOSED
MALL DRIVEWAY CLOSED
XXXXXXXX BLVD CLOSED

Other Condition List

FRONTAGE ROAD CLOSED
SHOULDER CLOSED XXX FT
RIGHT LN CLOSED XXX FT
RIGHT X LANES OPEN
DAYTIME LANE CLOSURES
I-XX SOUTH EXIT CLOSED
EXIT XXX CLOSED X MILE
RIGHT LN TO BE CLOSED
X LANES CLOSED TUE - FRI

ROADWORK XXX FT
FLAGGER XXXX FT
RIGHT LN NARROWS XXXX FT
MERGING TRAFFIC XXXX FT
LOOSE GRAVEL XXXX FT
DETOUR X MILE
ROADWORK PAST SH XXXX
BUMP XXXX FT
TRAFFIC SIGNAL XXXX FT

ROAD REPAIRS XXXX FT
LANE NARROWS XXXX FT
TWO-WAY TRAFFIC XX MILE
CONST TRAFFIC XXX FT
UNEVEN LANES XXXX FT
ROUGH ROAD XXXX FT
ROADWORK NEXT FRI-SUN
US XXX EXIT X MILES
LANES SHIFT *

* LANES SHIFT in Phase 1 must be used with STAY IN LANE in Phase 2.

Phase 2: Possible Component Lists

Action to Take/Effect on Travel List

MERGE RIGHT
DETOUR NEXT X EXITS
USE EXIT XXX
STAY ON US XXX SOUTH
TRUCKS USE US XXX N
WATCH FOR TRUCKS
EXPECT DELAYS
REDUCE SPEED XXX FT
USE OTHER ROUTES
STAY IN LANE *

FORM X LINES RIGHT
USE XXXXX RD EXIT
USE EXIT I-XX NORTH
USE I-XX E TO I-XX N
WATCH FOR TRUCKS
EXPECT DELAYS
PREPARE TO STOP
END SHOULDER USE
WATCH FOR WORKERS

Location List

AT FM XXXX
BEFORE RAILROAD CROSSING
NEXT X MILES
PAST US XXX EXIT
XXXXXXXX TO XXXXXX
US XXX TO FM XXXX

Warning List

SPEED LIMIT XX MPH
MAXIMUM SPEED XX MPH
MINIMUM SPEED XX MPH
ADVISORY SPEED XX MPH
RIGHT LANE EXIT
USE CAUTION
DRIVE SAFELY
DRIVE WITH CARE

** Advance Notice List

TUE-FRI XX AM-X PM
APR XX-XX X PM-X AM
BEGINS MONDAY
BEGINS MAY XX
MAY X-X XX PM - XX AM
NEXT FRI-SUN
XX AM TO XX PM
NEXT TUE AUG XX
TONIGHT XX PM-XX AM

** See Application Guidelines Note 6.

APPLICATION GUIDELINES

- Only 1 or 2 phases are to be used on a PCMS.
- The 1st phase (or both) should be selected from the "Road/Lane/Ramp Closure List" and the "Other Condition List".
- A 2nd phase can be selected from the "Action to Take/Effect on Travel, Location, General Warning, or Advance Notice Phase Lists".
- A Location Phase is necessary only if a distance or location is not included in the first phase selected.
- If two PCMS are used in sequence, they must be separated by a minimum of 1000 ft. Each PCMS shall be limited to two phases, and should be understandable by themselves.
- For advance notice, when the current date is within seven days of the actual work date, calendar days should be replaced with days of the week. Advance notification should typically be for no more than one week prior to the work.

WORDING ALTERNATIVES

- The words RIGHT, LEFT and ALL can be interchanged as appropriate.
- Roadway designations IH, US, SH, FM and LP can be interchanged as appropriate.
- EAST, WEST, NORTH and SOUTH (or abbreviations E, W, N and S) can be interchanged as appropriate.
- Highway names and numbers replaced as appropriate.
- ROAD, HIGHWAY and FREEWAY can be interchanged as needed.
- AHEAD may be used instead of distances if necessary.
- FT and MI, MILE and MILES interchanged as appropriate.
- AT, BEFORE and PAST interchanged as needed.
- Distances or AHEAD can be eliminated from the message if a location phase is used.

PCMS SIGNS WITHIN THE R.O.W. SHALL BE BEHIND GUARDRAIL OR CONCRETE BARRIER OR SHALL HAVE A MINIMUM OF FOUR (4) PLASTIC DRUMS PLACED PERPENDICULAR TO TRAFFIC ON THE UPSTREAM SIDE OF THE PCMS, WHEN EXPOSED TO ONE DIRECTION OF TRAFFIC. WHEN EXPOSED TO TWO WAY TRAFFIC, THE FOUR DRUMS SHOULD BE PLACED WITH ONE DRUM AT EACH OF THE FOUR CORNERS OF THE UNIT.

FULL MATRIX PCMS SIGNS

- When Full Matrix PCMS signs are used, the character height and legibility/visibility requirements shall be maintained as listed in Note 15 under "PORTABLE CHANGEABLE MESSAGE SIGNS" above.
- When symbol signs, such as the "Flagger Symbol" (CW20-7) are represented graphically on the Full Matrix PCMS sign and, with the approval of the Engineer, it shall maintain the legibility/visibility requirement listed above.
- When symbol signs are represented graphically on the Full Matrix PCMS, they shall only supplement the use of the static sign represented, and shall not substitute for, or replace that sign.
- A full matrix PCMS may be used to simulate a flashing arrow board provided it meets the visibility, flash rate and dimming requirements on BC(7), for the same size arrow.

SHEET 6 OF 12



BARRICADE AND CONSTRUCTION PORTABLE CHANGEABLE MESSAGE SIGN (PCMS)

BC (6) - 21

FILE: bc-21.dgn	DN: TxDOT	CK: TxDOT	DW: TxDOT	CR: TxDOT
© TxDOT November 2002	CONT	SECT	JOB	HIGHWAY
REVISIONS	0095 14	033, ETC	IH 20, ETC	
9-07 8-14	DIST	COUNTY	SHEET NO.	
7-13 5-21	DAL	KAUFMAN, ETC	83	

DATE: 3/17/2023 4:30:10 PM
FILE: T:\DAL\TRAFFIC\2023 PS&E\I.H. 20\Plan Set\standards\non-paf_standards\078 - 089 BC(1) TO (12) - 21.dgn

DISCLAIMER: The use of this standard is governed by the "Texas Engineering Practice Act". No warranty of any kind is made by TxDOT for any purpose whatsoever. TxDOT assumes no responsibility for the conversion of this standard to other formats or for incorrect results or damages resulting from its use.

DATE: 3/17/2023 4:30:11 PM
 FILE: T:\DAL\TRAFFIC\2023 PS&E\I.H. 20\Plan Set\Standards\non-pdf standard.dwg - 089 BC(1) TO (12) - 21.dgn

- Barrier Reflectors shall be pre-qualified, and conform to the color and reflectivity requirements of DMS-8600. A list of prequalified Barrier Reflectors can be found at the Material Producer List web address shown on BC(1).
- Color of Barrier Reflectors shall be as specified in the TMUTCD. The cost of the reflectors shall be considered subsidiary to Item 512.

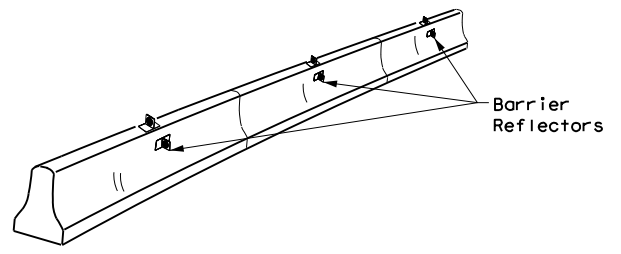

CONCRETE TRAFFIC BARRIER (CTB)

- Where traffic is on one side of the CTB, two (2) Barrier Reflectors shall be mounted in approximately the midsection of each section of CTB. An alternate mounting location is uniformly spaced at one end of each CTB. This will allow for attachment of a barrier grapple without damaging the reflector. The Barrier Reflector mounted on the side of the CTB shall be located directly below the reflector mounted on top of the barrier, as shown in the detail above.
- Where CTB separates two-way traffic, three barrier reflectors shall be mounted on each section of CTB. The reflector unit on top shall have two yellow reflective faces (Bi-Directional) while the reflectors on each side of the barrier shall have one yellow reflective face, as shown in the detail above.
- When CTB separates traffic traveling in the same direction, no barrier reflectors will be required on top of the CTB.
- Barrier Reflector units shall be yellow or white in color to match the edgeline being supplemented.
- Maximum spacing of Barrier Reflectors is forty (40) feet.
- Pavement markers or temporary flexible-reflective roadway marker tabs shall NOT be used as CTB delineation.
- Attachment of Barrier Reflectors to CTB shall be per manufacturer's recommendations.
- Missing or damaged Barrier Reflectors shall be replaced as directed by the Engineer.
- Single slope barriers shall be delineated as shown on the above detail.

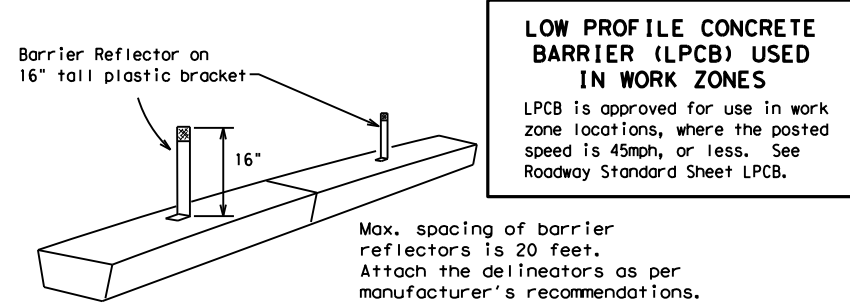

LOW PROFILE CONCRETE BARRIER (LPCB) USED IN WORK ZONES
 LPCB is approved for use in work zone locations, where the posted speed is 45mph, or less. See Roadway Standard Sheet LPCB.

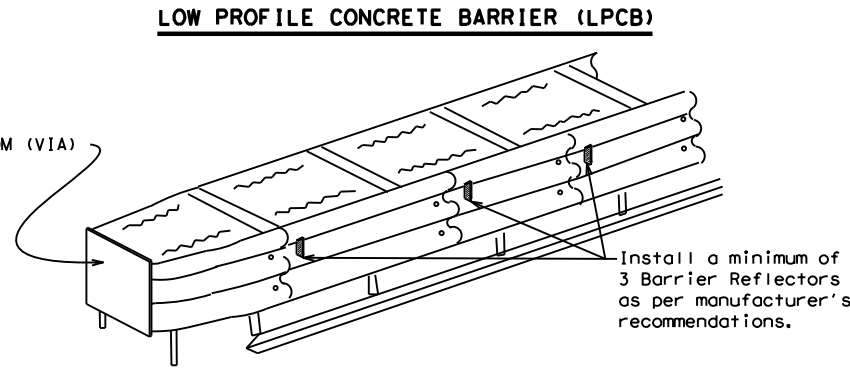

DELINEATION OF END TREATMENTS
END TREATMENTS FOR CTB'S USED IN WORK ZONES
 End treatments used on CTB's in work zones shall meet the appropriate crashworthy standards as defined in the Manual for Assessing Safety Hardware (MASH). Refer to the CWZTCD List for approved end treatments and manufacturers.

BARRIER REFLECTORS FOR CONCRETE TRAFFIC BARRIER AND ATTENUATORS

WARNING LIGHTS

- Warning lights shall meet the requirements of the TMUTCD.
- Warning lights shall NOT be installed on barricades.
- Type A-Low Intensity Flashing Warning Lights are commonly used with drums. They are intended to warn of or mark a potentially hazardous area. Their use shall be as indicated on this sheet and/or other sheets of the plans by the designation "FL". The Type A Warning Lights shall not be used with signs manufactured with Type B_{FL} or C_{FL} Sheeting meeting the requirements of Departmental Material Specification DMS-8300.
- Type-C and Type D 360 degree Steady Burn Lights are intended to be used in a series for delineation to supplement other traffic control devices. Their use shall be as indicated on this sheet and/or other sheets of the plans by the designation "SB".
- The Engineer/Inspector or the plans shall specify the location and type of warning lights to be installed on the traffic control devices.
- When required by the Engineer, the Contractor shall furnish a copy of the warning lights certification. The warning light manufacturer will certify the warning lights meet the requirements of the latest ITE Purchase Specifications for Flashing and Steady-Burn Warning Lights.
- When used to delineate curves, Type-C and Type D Steady Burn Lights should only be placed on the outside of the curve, not the inside.
- The location of warning lights and warning reflectors on drums shall be as shown elsewhere in the plans.

WARNING LIGHTS MOUNTED ON PLASTIC DRUMS

- Type A flashing warning lights are intended to warn drivers that they are approaching or are in a potentially hazardous area.
- Type A random flashing warning lights are not intended for delineation and shall not be used in a series.
- A series of sequential flashing warning lights placed on channelizing devices to form a merging taper may be used for delineation. If used, the successive flashing of the sequential warning lights should occur from the beginning of the taper to the end of the merging taper in order to identify the desired vehicle path. The rate of flashing for each light shall be 65 flashes per minute, plus or minus 10 flashes.
- Type C and D steady-burn warning lights are intended to be used in a series to delineate the edge of the travel lane on detours, on lane changes, on lane closures, and on other similar conditions.
- Type A, Type C and Type D warning lights shall be installed at locations as detailed on other sheets in the plans.
- Warning lights shall not be installed on a drum that has a sign, chevron or vertical panel.
- The maximum spacing for warning lights on drums should be identical to the channelizing device spacing.

WARNING REFLECTORS MOUNTED ON PLASTIC DRUMS AS A SUBSTITUTE FOR TYPE C (STEADY BURN) WARNING LIGHTS

- A warning reflector or approved substitute may be mounted on a plastic drum as a substitute for a Type C, steady burn warning light at the discretion of the Contractor unless otherwise noted in the plans.
- The warning reflector shall be yellow in color and shall be manufactured using a sign substrate approved for use with plastic drums listed on the CWZTCD.
- The warning reflector shall have a minimum retroreflective surface area (one-side) of 30 square inches.
- Round reflectors shall be fully reflectorized, including the area where attached to the drum.
- Square substrates must have a minimum of 30 square inches of reflectorized sheeting. They do not have to be reflectorized where it attaches to the drum.
- The side of the warning reflector facing approaching traffic shall have sheeting meeting the color and retroreflectivity requirements for DMS 8300-Type B or Type C.
- When used near two-way traffic, both sides of the warning reflector shall be reflectorized.
- The warning reflector should be mounted on the side of the handle nearest approaching traffic.
- The maximum spacing for warning reflectors should be identical to the channelizing device spacing requirements.

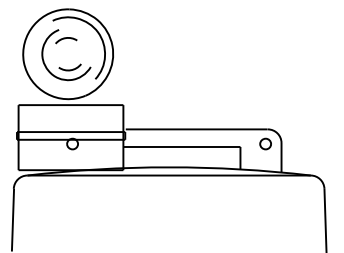

Type C Warning Light or approved substitute mounted on a drum adjacent to the travel way.

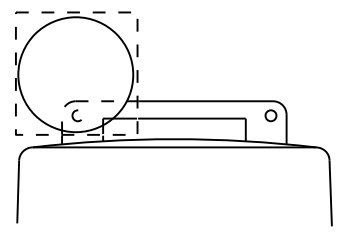

Warning reflector may be round or square. Must have a yellow reflective surface area of at least 30 square inches

Arrow Boards may be located behind channelizing devices in place for a shoulder taper or merging taper, otherwise they shall be delineated with four (4) channelizing devices placed perpendicular to traffic on the upstream side of traffic.

- The Flashing Arrow Board should be used for all lane closures on multi-lane roadways, or slow moving maintenance or construction activities on the travel lanes.
- Flashing Arrow Boards should not be used on two-lane, two-way roadways, detours, diversions or work on shoulders unless the "CAUTION" display (see detail below) is used.
- The Engineer/Inspector shall choose all appropriate signs, barricades and/or other traffic control devices that should be used in conjunction with the Flashing Arrow Board.
- The Flashing Arrow Board should be able to display the following symbols:

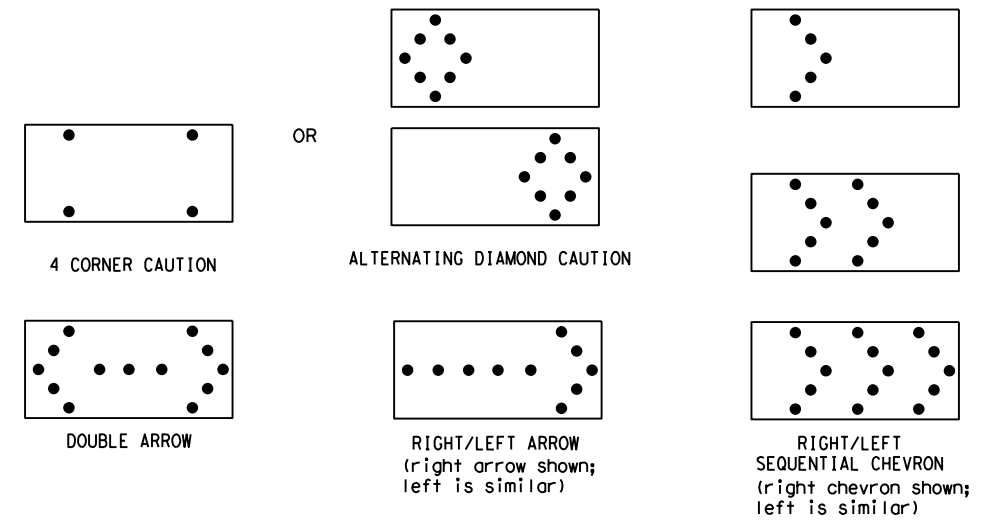

- The "CAUTION" display consists of four corner lamps flashing simultaneously, or the Alternating Diamond Caution mode as shown.
- The straight line caution display is NOT ALLOWED.
- The Flashing Arrow Board shall be capable of minimum 50 percent dimming from rated lamp voltage. The flashing rate of the lamps shall not be less than 25 nor more than 40 flashes per minute.
- Minimum lamp "on time" shall be approximately 50 percent for the flashing arrow and equal intervals of 25 percent for each sequential phase of the flashing chevron.
- The sequential arrow display is NOT ALLOWED.
- The flashing arrow display is the TxDOT standard; however, the sequential chevron display may be used during daylight operations.
- The Flashing Arrow Board shall be mounted on a vehicle, trailer or other suitable support.
- A Flashing Arrow Board SHALL NOT BE USED to laterally shift traffic.
- A full matrix PCMS may be used to simulate a Flashing Arrow Board provided it meets visibility, flash rate and dimming requirements on this sheet for the same size arrow.
- Minimum mounting height of trailer mounted Arrow Boards should be 7 feet from roadway to bottom of panel.

REQUIREMENTS			
TYPE	MINIMUM SIZE	MINIMUM NUMBER OF PANEL LAMPS	MINIMUM VISIBILITY DISTANCE
B	30 x 60	13	3/4 mile
C	48 x 96	15	1 mile

ATTENTION
 Flashing Arrow Boards shall be equipped with automatic dimming devices.

WHEN NOT IN USE, REMOVE THE ARROW BOARD FROM THE RIGHT-OF-WAY OR PLACE THE ARROW BOARD BEHIND CONCRETE TRAFFIC BARRIER OR GUARDRAIL.

FLASHING ARROW BOARDS

SHEET 7 OF 12

TRUCK-MOUNTED ATTENUATORS

- Truck-mounted attenuators (TMA) used on TxDOT facilities must meet the requirements outlined in the Manual for Assessing Safety Hardware (MASH).
- Refer to the CWZTCD for the requirements of Level 2 or Level 3 TMAs.
- Refer to the CWZTCD for a list of approved TMAs.
- TMAs are required on freeways unless otherwise noted in the plans.
- A TMA should be used anytime that it can be positioned 30 to 100 feet in advance of the area of crew exposure without adversely affecting the work performance.
- The only reason a TMA should not be required is when a work area is spread down the roadway and the work crew is an extended distance from the TMA.



BARRICADE AND CONSTRUCTION ARROW PANEL, REFLECTORS, WARNING LIGHTS & ATTENUATOR

BC (7) - 21

FILE:	bc-21.dgn	DN:	TxDOT	CR:	TxDOT	OW:	TxDOT	CK:	TxDOT
© TxDOT	November 2002	CONT	SECT	JOB	HIGHWAY				
REVISIONS		0095	14	033, ETC		IH 20, ETC			
9-07	8-14	DIST	COUNTY		SHEET NO.				
7-13	5-21	DAL	KAUFMAN, ETC		84				

DATE: 3/17/2023 4:30:13 PM
 FILE: T:\DAL\TRAFFIC\2023 PS&E\I\H 20\Plan Set\Standards\non-paf standard\ds\078 - 089 BC(1) TO (12) - 21.dgn
 DISCLAIMER: The use of this standard is governed by the "Texas Engineering Practice Act". No warranty of any kind is made by TxDOT for any purpose whatsoever. TxDOT assumes no responsibility for the conversion of this standard to other formats or for incorrect results or damages resulting from its use.

GENERAL NOTES

- For long term stationary work zones on freeways, drums shall be used as the primary channelizing device.
- For intermediate term stationary work zones on freeways, drums should be used as the primary channelizing device but may be replaced in tangent sections by vertical panels, or 42" two-piece cones. In tangent sections, one-piece cones may be used with the approval of the Engineer but only if personnel are present on the project at all times to maintain the cones in proper position and location.
- For short term stationary work zones on freeways, drums are the preferred channelizing device but may be replaced in tapers, transitions and tangent sections by vertical panels, two-piece cones or one-piece cones as approved by the Engineer.
- Drums and all related items shall comply with the requirements of the current version of the "Texas Manual on Uniform Traffic Control Devices" (TMUTCD) and the "Compliant Work Zone Traffic Control Devices List" (CWZTCD).
- Drums, bases, and related materials shall exhibit good workmanship and shall be free from objectionable marks or defects that would adversely affect their appearance or serviceability.
- The Contractor shall have a maximum of 24 hours to replace any plastic drums identified for replacement by the Engineer/Inspector. The replacement device must be an approved device.

GENERAL DESIGN REQUIREMENTS

- Pre-qualified plastic drums shall meet the following requirements:
- Plastic drums shall be a two-piece design; the "body" of the drum shall be the top portion and the "base" shall be the bottom.
 - The body and base shall lock together in such a manner that the body separates from the base when impacted by a vehicle traveling at a speed of 20 MPH or greater but prevents accidental separation due to normal handling and/or air turbulence created by passing vehicles.
 - Plastic drums shall be constructed of lightweight flexible, and deformable materials. The Contractor shall NOT use metal drums or single piece plastic drums as channelization devices or sign supports.
 - Drums shall present a profile that is a minimum of 18 inches in width at the 36 inch height when viewed from any direction. The height of drum unit (body installed on base) shall be a minimum of 36 inches and a maximum of 42 inches.
 - The top of the drum shall have a built-in handle for easy pickup and shall be designed to drain water and not collect debris. The handle shall have a minimum of two widely spaced 9/16 inch diameter holes to allow attachment of a warning light, warning reflector unit or approved compliant sign.
 - The exterior of the drum body shall have a minimum of four alternating orange and white retroreflective circumferential stripes not less than 4 inches nor greater than 8 inches in width. Any non-reflectorized space between any two adjacent stripes shall not exceed 2 inches in width.
 - Bases shall have a maximum width of 36 inches, a maximum height of 4 inches, and a minimum of two footholds of sufficient size to allow base to be held down while separating the drum body from the base.
 - Plastic drums shall be constructed of ultra-violet stabilized, orange, high-density polyethylene (HDPE) or other approved material.
 - Drum body shall have a maximum unballasted weight of 11 lbs.
 - Drum and base shall be marked with manufacturer's name and model number.

RETROREFLECTIVE SHEETING

- The stripes used on drums shall be constructed of sheeting meeting the color and retroreflectivity requirements of Departmental Materials Specification DMS-8300, "Sign Face Materials." Type A or Type B reflective sheeting shall be supplied unless otherwise specified in the plans.
- The sheeting shall be suitable for use on and shall adhere to the drum surface such that, upon vehicular impact, the sheeting shall remain adhered in-place and exhibit no delaminating, cracking, or loss of retroreflectivity other than that loss due to abrasion of the sheeting surface.

BALLAST

- Unballasted bases shall be large enough to hold up to 50 lbs. of sand. This base, when filled with the ballast material, should weigh between 35 lbs (minimum) and 50 lbs (maximum). The ballast may be sand in one to three sandbags separate from the base, sand in a sand-filled plastic base, or other ballasting devices as approved by the Engineer. Stacking of sandbags will be allowed, however height of sandbags above pavement surface may not exceed 12 inches.
- Bases with built-in ballast shall weigh between 40 lbs. and 50 lbs. Built-in ballast can be constructed of an integral crumb rubber base or a solid rubber base.
- Recycled truck tire sidewalls may be used for ballast on drums approved for this type of ballast on the CWZTCD list.
- The ballast shall not be heavy objects, water, or any material that would become hazardous to motorists, pedestrians, or workers when the drum is struck by a vehicle.
- When used in regions susceptible to freezing, drums shall have drainage holes in the bottoms so that water will not collect and freeze becoming a hazard when struck by a vehicle.
- Ballast shall not be placed on top of drums.
- Adhesives may be used to secure base of drums to pavement.

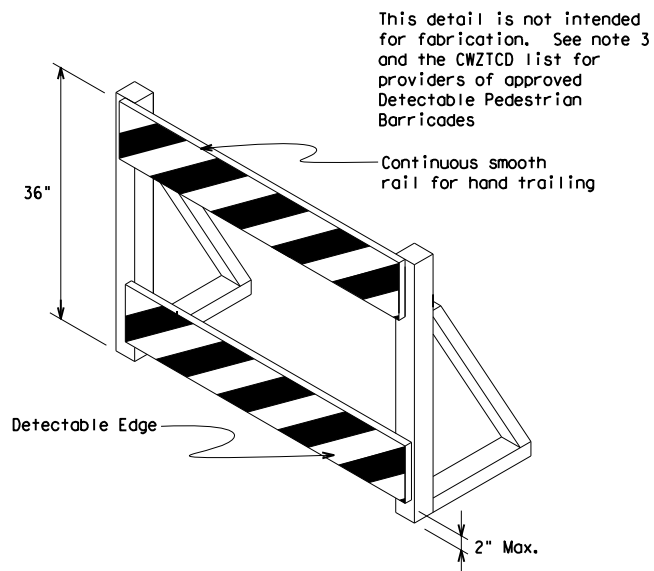
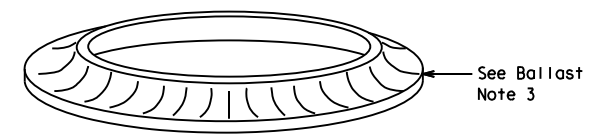
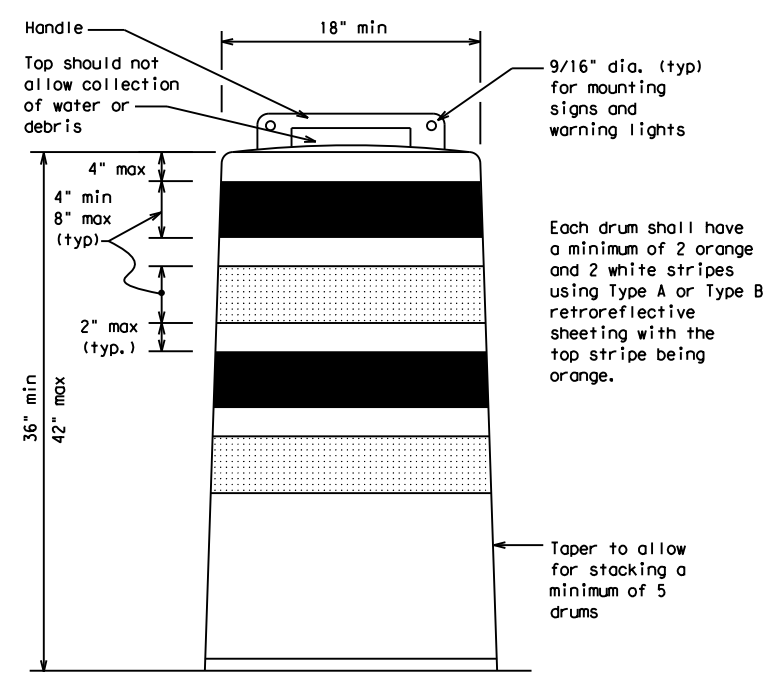

DETECTABLE PEDESTRIAN BARRICADES

- When existing pedestrian facilities are disrupted, closed, or relocated in a TTC zone, the temporary facilities shall be detectable and include accessibility features consistent with the features present in the existing pedestrian facility. Refer to WZ(BTS-2) for Pedestrian Control requirements for Sidewalk Diversions, Sidewalk Detours and Crosswalk Closures.
- Where pedestrians with visual disabilities normally use the closed sidewalk, a Detectable Pedestrian Barricade shall be placed across the full width of the closed sidewalk instead of a Type 3 Barricade.
- Detectable pedestrian barricades similar to the one pictured above, longitudinal channelizing devices, some concrete barriers, and wood or chain link fencing with a continuous detectable edging can satisfactorily delineate a pedestrian path.
- Tape, rope, or plastic chain strung between devices are not detectable, do not comply with the design standards in the "Americans with Disabilities Act Accessibility Guidelines (ADAAG)" and should not be used as a control for pedestrian movements.
- Warning lights shall not be attached to detectable pedestrian barricades.
- Detectable pedestrian barricades should use 8" nominal barricade rails as shown on BC(10) provided that the top rail provides a smooth continuous rail suitable for hand trailing with no splinters, burrs, or sharp edges.

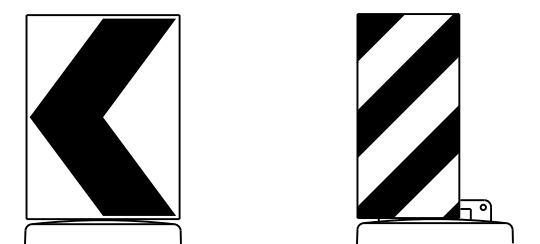

18" x 24" Sign (Maximum Sign Dimension)
Chevron CW1-8, Opposing Traffic Lane Divider, Driveway sign D70a, Keep Right R4 series or other signs as approved by Engineer

12" x 24" Vertical Panel
mount with diagonals sloping down towards travel way

Plywood, Aluminum or Metal sign substrates shall NOT be used on plastic drums

SIGNS, CHEVRONS, AND VERTICAL PANELS MOUNTED ON PLASTIC DRUMS

- Signs used on plastic drums shall be manufactured using substrates listed on the CWZTCD.
- Chevrons and other work zone signs with an orange background shall be manufactured with Type B_{FL} or Type C_{FL} Orange sheeting meeting the color and retroreflectivity requirements of DMS-8300, "Sign Face Material," unless otherwise specified in the plans.
- Vertical Panels shall be manufactured with orange and white sheeting meeting the requirements of DMS-8300 Type A or Type B. Diagonal stripes on Vertical Panels shall slope down toward the intended traveled lane.
- Other sign messages (text or symbolic) may be used as approved by the Engineer. Sign dimensions shall not exceed 18 inches in width or 24 inches in height, except for the R9 series signs discussed in note 8 below.
- Signs shall be installed using a 1/2 inch bolt (nominal) and nut, two washers, and one locking washer for each connection.
- Mounting bolts and nuts shall be fully engaged and adequately torqued. Bolts should not extend more than 1/2 inch beyond nuts.
- Chevrons may be placed on drums on the outside of curves, on merging tapers or on shifting tapers. When used in these locations, they may be placed on every drum or spaced not more than on every third drum. A minimum of three (3) should be used at each location called for in the plans.
- R9-9, R9-10, R9-11 and R9-11a Sidewalk Closed signs which are 24 inches wide may be mounted on plastic drums, with approval of the Engineer.

SHEET 8 OF 12



BARRICADE AND CONSTRUCTION CHANNELIZING DEVICES

BC (8) - 21

FILE:	bc-21.dgn	DN:	TxDOT	CR:	TxDOT	OW:	TxDOT	CK:	TxDOT
© TxDOT	November 2002	CONT	SECT	JOB	HIGHWAY				
REVISIONS		0095	14	033, ETC		IH 20, ETC			
4-03	8-14	DIST	COUNTY	SHEET NO.					
9-07	5-21	DAL	KAUFMAN, ETC	85					
7-13									

DISCLAIMER: The use of this standard is governed by the "Texas Engineering Practice Act". No warranty of any kind is made by TxDOT for any purpose whatsoever. TxDOT assumes no responsibility for the conversion of this standard to other formats or for incorrect results or damages resulting from its use.

DATE: 3/17/2023 4:30:14 PM
 FILE: T:\DAL\TRAFFIC\2023 PS&E\H.20\Plan_Sets\standards\non-pdf_standards\078 - 089 BC(1) TO (12) - 21.dgn

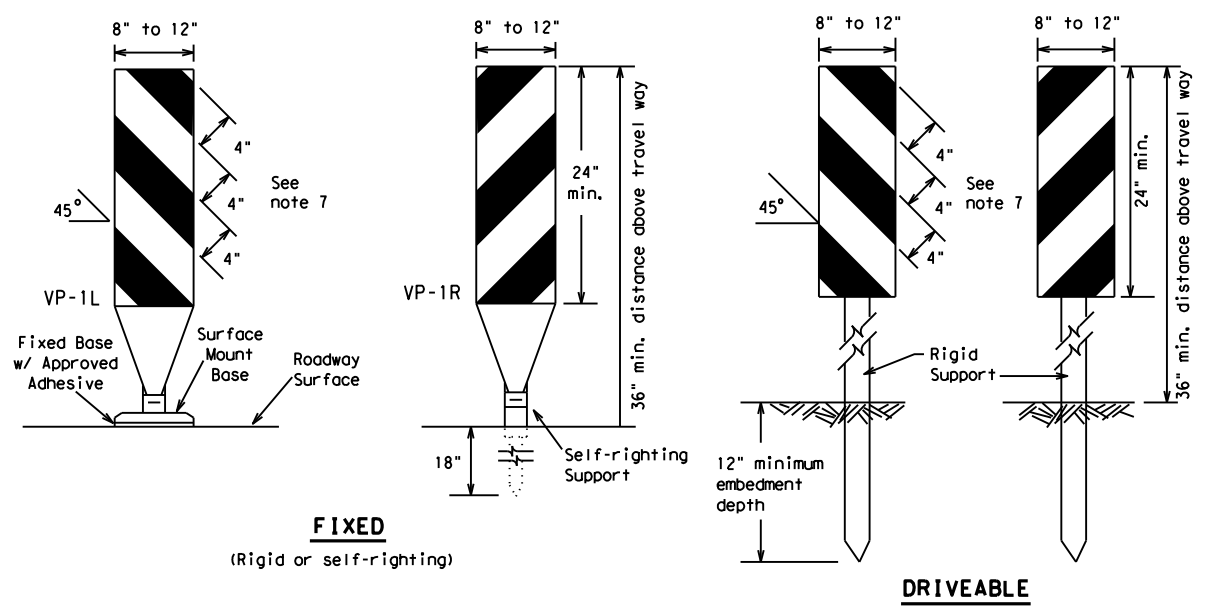

FIXED
(Rigid or self-righting)

DRIVEABLE

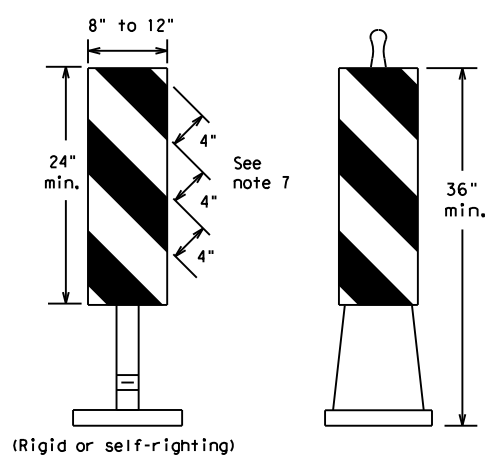

PORTABLE

VERTICAL PANELS (VPs)

- Vertical Panels (VP's) are normally used to channelize traffic or divide opposing lanes of traffic.
- VP's may be used in daytime or nighttime situations. They may be used at the edge of shoulder drop-offs and other areas such as lane transitions where positive daytime and nighttime delineation is required. The Engineer/Inspector shall refer to the Roadway Design Manual for additional requirements on the use VP's for drop-offs.
- VP's should be mounted back to back if used at the edge of cuts adjacent to two-way two lane roadways. Stripes are to be reflective orange and reflective white and should always slope downward toward the travel lane.
- VP's used on expressways and freeways or other high speed roadways, may have more than 270 square inches of retroreflective area facing traffic.
- Self-righting supports are available with portable base. See "Compliant Work Zone Traffic Control Devices List" (CWZTCD).
- Sheeting for the VP's shall be retroreflective Type A or Type B conforming to Departmental Material Specification DMS-8300, unless noted otherwise.
- Where the height of reflective material on the vertical panel is 36 inches or greater, a panel stripe of 6 inches shall be used.

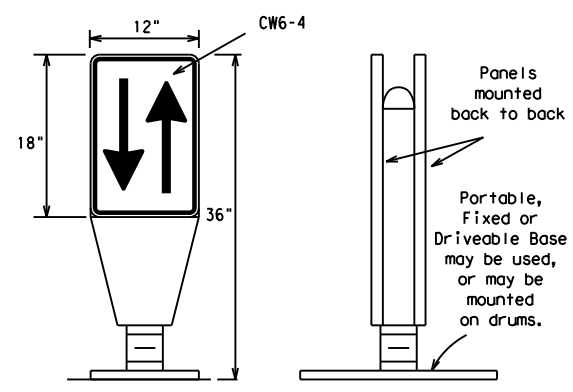

OPPOSING TRAFFIC LANE DIVIDERS (OTLD)

- Opposing Traffic Lane Dividers (OTLD) are delineation devices designed to convert a normal one-way roadway section to two-way operation. OTLD's are used on temporary centerlines. The upward and downward arrows on the sign's face indicate the direction of traffic on either side of the divider. The base is secured to the pavement with an adhesive or rubber weight to minimize movement caused by a vehicle impact or wind gust.
- The OTLD may be used in combination with 42" cones or VPs.
- Spacing between the OTLD shall not exceed 500 feet. 42" cones or VPs placed between the OTLD's should not exceed 100 foot spacing.
- The OTLD shall be orange with a black non-reflective legend. Sheeting for the OTLD shall be retroreflective Type B_{FL} or Type C_{FL} conforming to Departmental Material Specification DMS-8300, unless noted otherwise. The legend shall meet the requirements of DMS-8300.

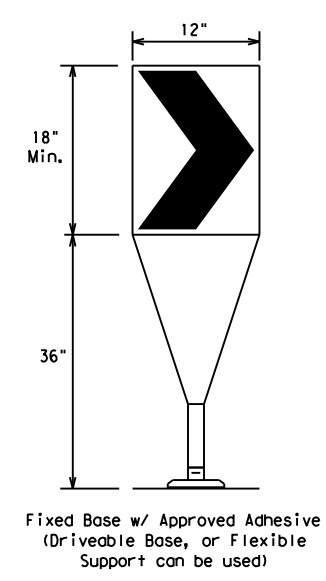

Fixed Base w/ Approved Adhesive (Driveable Base, or Flexible Support can be used)

- The chevron shall be a vertical rectangle with a minimum size of 12 by 18 inches.
- Chevrons are intended to give notice of a sharp change of alignment with the direction of travel and provide additional emphasis and guidance for vehicle operators with regard to changes in horizontal alignment of the roadway.
- Chevrons, when used, shall be erected on the outside of a sharp curve or turn, or on the far side of an intersection. They shall be in line with and at right angles to approaching traffic. Spacing should be such that the motorist always has three in view, until the change in alignment eliminates its need.
- To be effective, the chevron should be visible for at least 500 feet.
- Chevrons shall be orange with a black nonreflective legend. Sheeting for the chevron shall be retroreflective Type B_{FL} or Type C_{FL} conforming to Departmental Material Specification DMS-8300, unless noted otherwise. The legend shall meet the requirements of DMS-8300.
- For Long Term Stationary use on tapers or transitions on freeways and divided highways, self-righting chevrons may be used to supplement plastic drums but not to replace plastic drums.

CHEVRONS

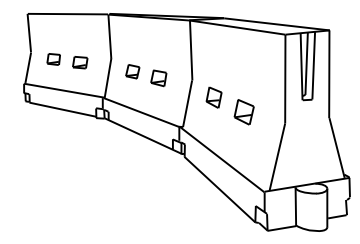

LONGITUDINAL CHANNELIZING DEVICES (LCD)

- LCDs are crashworthy, lightweight, deformable devices that are highly visible, have good target value and can be connected together. They are not designed to contain or redirect a vehicle on impact.
- LCDs may be used instead of a line of cones or drums.
- LCDs shall be placed in accordance to application and installation requirements specific to the device, and used only when shown on the CWZTCD list.
- LCDs should not be used to provide positive protection for obstacles, pedestrians or workers.
- LCDs shall be supplemented with retroreflective delineation as required for temporary barriers on BC(7) when placed roughly parallel to the travel lanes.
- LCDs used as barricades placed perpendicular to traffic should have at least one row of reflective sheeting meeting the requirements for barricade rails as shown on BC(10). Place reflective sheeting near the top of the LCD along the full length of the device.

WATER BALLASTED SYSTEMS USED AS BARRIERS

- Water ballasted systems used as barriers shall not be used solely to channelize road users, but also to protect the work space per the appropriate Manual for Assessing Safety Hardware (MASH) crashworthiness requirements based on roadway speed and barrier application.
- Water ballasted systems used to channelize vehicular traffic shall be supplemented with retroreflective delineation or channelizing devices to improve daytime/nighttime visibility. They may also be supplemented with pavement markings.
- Water ballasted systems used as barriers shall be placed in accordance to application and installation requirements specific to the device, and used only when shown on the CWZTCD list.
- Water ballasted systems used as barriers should not be used for a merging taper except in low speed (less than 45 MPH) urban areas. When used on a taper in a low speed urban area, the taper shall be delineated and the taper length should be designed to optimize road user operations considering the available geometric conditions.
- When water ballasted systems used as barriers have blunt ends exposed to traffic, they should be attenuated as per manufacturer recommendations or flared to a point outside the clear zone.

If used to channelize pedestrians, longitudinal channelizing devices or water ballasted systems must have a continuous detectable bottom for users of long canes and the top of the unit shall not be less than 32 inches in height.

HOLLOW OR WATER BALLASTED SYSTEMS USED AS LONGITUDINAL CHANNELIZING DEVICES OR BARRIERS

GENERAL NOTES

- Work Zone channelizing devices illustrated on this sheet may be installed in close proximity to traffic and are suitable for use on high or low speed roadways. The Engineer/Inspector shall ensure that spacing and placement is uniform and in accordance with the "Texas Manual on Uniform Traffic Control Devices" (TMUTCD).
- Channelizing devices shown on this sheet may have a driveable, fixed or portable base. The requirement for self-righting channelizing devices must be specified in the General Notes or other plan sheets.
- Channelizing devices on self-righting supports should be used in work zone areas where channelizing devices are frequently impacted by errant vehicles or vehicle related wind gusts making alignment of the channelizing devices difficult to maintain. Locations of these devices shall be detailed elsewhere in the plans. These devices shall conform to the TMUTCD and the "Compliant Work Zone Traffic Control Devices List" (CWZTCD).
- The Contractor shall maintain devices in a clean condition and replace damaged, nonreflective, faded, or broken devices and bases as required by the Engineer/Inspector. The Contractor shall be required to maintain proper device spacing and alignment.
- Portable bases shall be fabricated from virgin and/or recycled rubber. The portable bases shall weigh a minimum of 30 lbs.
- Pavement surfaces shall be prepared in a manner that ensures proper bonding between the adhesives, the fixed mount bases and the pavement surface. Adhesives shall be prepared and applied according to the manufacturer's recommendations.
- The installation and removal of channelizing devices shall not cause detrimental effects to the final pavement surfaces, including pavement surface discoloration or surface integrity. Driveable bases shall not be permitted on final pavement surfaces. The Engineer/Inspector shall approve all application and removal procedures of fixed bases.

Posted Speed	Formula	Minimum Desirable Taper Lengths * *			Suggested Maximum Spacing of Channelizing Devices	
		10' Offset	11' Offset	12' Offset	On a Taper	On a Tangent
30	L = WS ² / 60	150'	165'	180'	30'	60'
35		205'	225'	245'	35'	70'
40		265'	295'	320'	40'	80'
45	L = WS	450'	495'	540'	45'	90'
50		500'	550'	600'	50'	100'
55		550'	605'	660'	55'	110'
60		600'	660'	720'	60'	120'
65		650'	715'	780'	65'	130'
70		700'	770'	840'	70'	140'
75		750'	825'	900'	75'	150'
80		800'	880'	960'	80'	160'

* * * Taper lengths have been rounded off.
 L=Length of Taper (FT.) W=Width of Offset (FT.)
 S=Posted Speed (MPH)

SUGGESTED MAXIMUM SPACING OF CHANNELIZING DEVICES AND MINIMUM DESIRABLE TAPER LENGTHS

SHEET 9 OF 12



BARRICADE AND CONSTRUCTION CHANNELIZING DEVICES

BC (9) - 21

FILE: bc-21.dgn	DN: TxDOT	CK: TxDOT	OW: TxDOT	CR: TxDOT
© TxDOT November 2002	CONT	SECT	JOB	HIGHWAY
REVISIONS	0095	14	033, ETC	IH 20, ETC
9-07 8-14	DIST	COUNTY	SHEET NO.	
7-13 5-21	DAL	KAUFMAN, ETC	86	

DATE: 3/17/2023 4:30:16 PM
 FILE: T:\DAL\TRAFFIC\2023 PS&E\I\H 20\Plan Set\Standards\non-paf standard.ds\078 - 089 BC(1) TO (12) - 21.dgn
 DISCLAIMER: The use of this standard is governed by the "Texas Engineering Practice Act". No warranty of any kind is made by TxDOT for any purpose whatsoever. TxDOT assumes no responsibility for the conversion of this standard to other formats or for incorrect results or damages resulting from its use.

TYPE 3 BARRICADES

1. Refer to the Compliant Work Zone Traffic Control Devices List (CWZTCD) for details of the Type 3 Barricades and a list of all materials used in the construction of Type 3 Barricades.
2. Type 3 Barricades shall be used at each end of construction projects closed to all traffic.
3. Barricades extending across a roadway should have stripes that slope downward in the direction toward which traffic must turn in detouring. When both right and left turns are provided, the chevron striping may slope downward in both directions from the center of the barricade. Where no turns are provided at a closed road, striping should slope downward in both directions toward the center of roadway.
4. Striping of rails, for the right side of the roadway, should slope downward to the left. For the left side of the roadway, striping should slope downward to the right.
5. Identification markings may be shown only on the back of the barricade rails. The maximum height of letters and/or company logos used for identification shall be 1".
6. Barricades shall not be placed parallel to traffic unless an adequate clear zone is provided.
7. Warning lights shall NOT be installed on barricades.
8. Where barricades require the use of weights to keep from turning over, the use of sandbags with dry, cohesionless sand is recommended. The sandbags will be tied shut to keep the sand from spilling and to maintain a constant weight. Sand bags shall not be stacked in a manner that covers any portion of a barricade rails reflective sheeting. Rock, concrete, iron, steel or other solid objects will NOT be permitted. Sandbags should weigh a minimum of 35 lbs and a maximum of 50 lbs. Sandbags shall be made of a durable material that tears upon vehicular impact. Rubber (such as tire inner tubes) shall not be used for sandbags. Sandbags shall only be placed along or upon the base supports of the device and shall not be suspended above ground level or hung with rope, wire, chains or other fasteners.
9. Sheeting for barricades shall be retroreflective Type A or Type B conforming to Departmental Material Specification DMS-8300 unless otherwise noted.

Barricades shall NOT be used as a sign support.



TYPICAL STRIPING DETAIL FOR BARRICADE RAIL



Stiffener may be inside or outside of support, but no more than 2 stiffeners shall be allowed on one barricade.

TYPICAL PANEL DETAIL FOR SKID OR POST TYPE BARRICADES

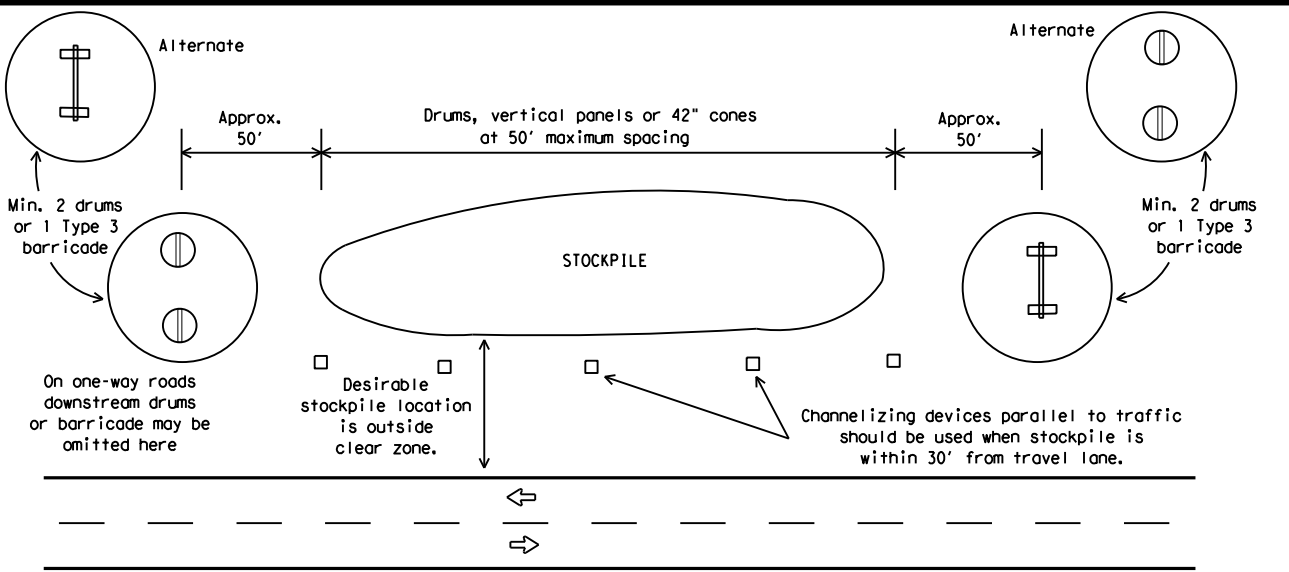

TRAFFIC CONTROL FOR MATERIAL STOCKPILES

Each roadway of a divided highway shall be barricaded in the same manner.

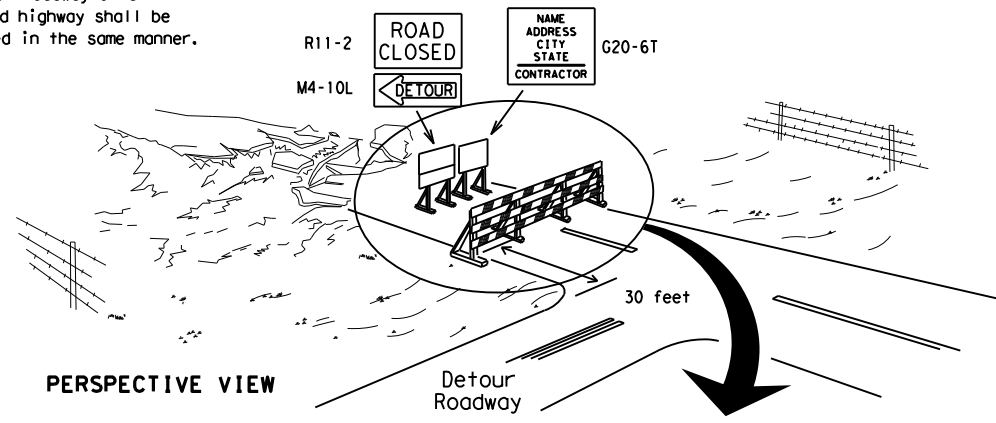

PERSPECTIVE VIEW

The three rails on Type 3 barricades shall be reflectorized orange and reflective white stripes on one side facing one-way traffic and both sides for two-way traffic. Barricade striping should slant downward in the direction of detour.

1. Signs should be mounted on independent supports at a 7 foot mounting height in center of roadway. The signs should be a minimum of 10 feet behind Type 3 Barricades.
2. Advance signing shall be as specified elsewhere in the plans.

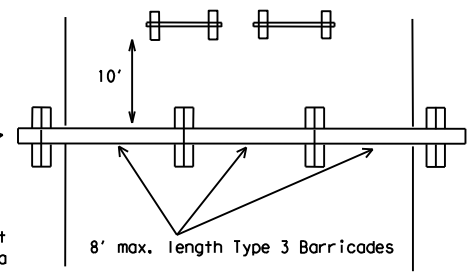

PLAN VIEW

TYPE 3 BARRICADE (POST AND SKID) TYPICAL APPLICATION

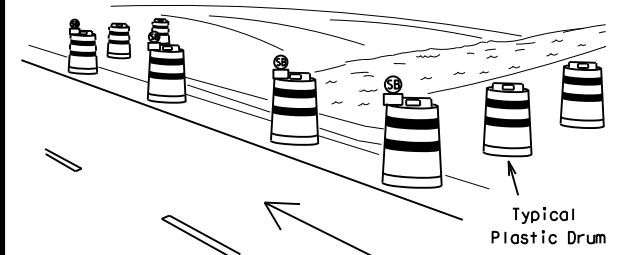

PERSPECTIVE VIEW

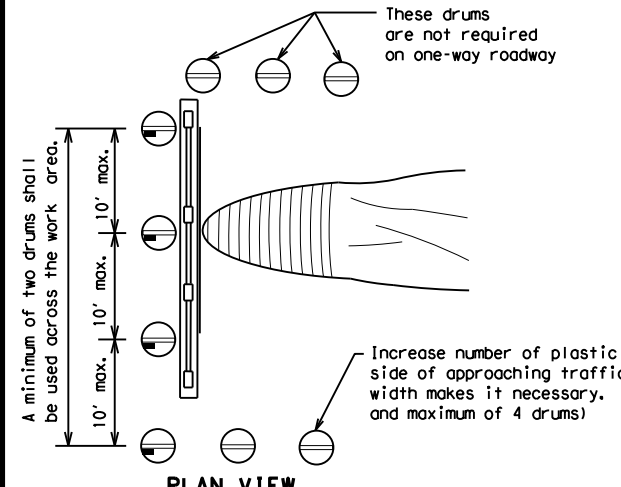

PLAN VIEW

CULVERT WIDENING OR OTHER ISOLATED WORK WITHIN THE PROJECT LIMITS

1. Where positive redirection capability is provided, drums may be omitted.
2. Plastic construction fencing may be used with drums for safety as required in the plans.
3. Vertical Panels on flexible support may be substituted for drums when the shoulder width is less than 4 feet.
4. When the shoulder width is greater than 12 feet, steady-burn lights may be omitted if drums are used.
5. Drums must extend the length of the culvert widening.

LEGEND	
	Plastic drum
	Plastic drum with steady burn light or yellow warning reflector
	Steady burn warning light or yellow warning reflector

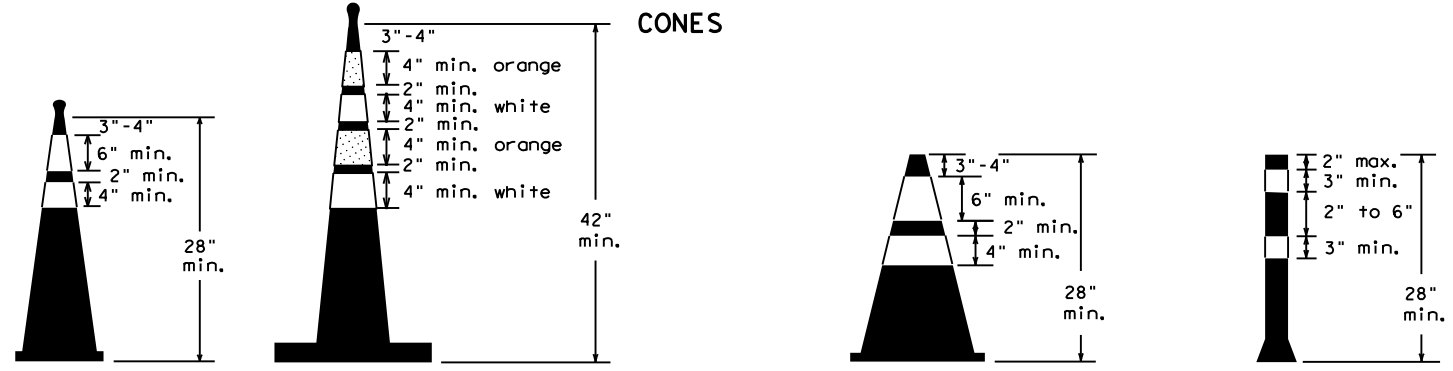

Two-Piece cones

One-Piece cones

Tubular Marker

28" Cones shall have a minimum weight of 9 1/2 lbs.
 42" 2-piece cones shall have a minimum weight of 30 lbs. including base.

1. Traffic cones and tubular markers shall be predominantly orange, and meet the height and weight requirements shown above.
2. One-piece cones have the body and base of the cone molded in one consolidated unit. Two-piece cones have a cone shaped body and a separate rubber base, or ballast, that is added to keep the device upright and in place.
3. Two-piece cones may have a handle or loop extending up to 8" above the minimum height shown, in order to aid in retrieving the device.
4. Cones or tubular markers shall have white or white and orange reflective bands as shown above. The reflective bands shall have a smooth, sealed outer surface and meet the requirements of Departmental Material Specification DMS-8300 Type A or Type B.
5. 28" cones and tubular markers are generally suitable for short duration and short-term stationary work as defined on BC(4). These should not be used for intermediate-term or long-term stationary work unless personnel is on-site to maintain them in their proper upright position.
6. 42" two-piece cones, vertical panels or drums are suitable for all work zone durations.
7. Cones or tubular markers used on each project should be of the same size and shape.



BARRICADE AND CONSTRUCTION CHANNELIZING DEVICES

BC (10) - 21

FILE: bc-21.dgn	DN: TxDOT	CK: TxDOT	OW: TxDOT	CR: TxDOT
© TxDOT November 2002	CONT	SECT	JOB	HIGHWAY
REVISIONS	0095 14	033, ETC	IH 20, ETC	
9-07 8-14	DIST	COUNTY	SHEET NO.	
7-13 5-21	DAL	KAUFMAN, ETC	87	

WORK ZONE PAVEMENT MARKINGS

GENERAL

- The Contractor shall be responsible for maintaining work zone and existing pavement markings, in accordance with the standard specifications and special provisions, on all roadways open to traffic within the CSJ limits unless otherwise stated in the plans.
- Color, patterns and dimensions shall be in conformance with the "Texas Manual on Uniform Traffic Control Devices" (TMUTCD).
- Additional supplemental pavement marking details may be found in the plans or specifications.
- Pavement markings shall be installed in accordance with the TMUTCD and as shown on the plans.
- When short term markings are required on the plans, short term markings shall conform with the TMUTCD, the plans and details as shown on the Standard Plan Sheet WZ(STPM).
- When standard pavement markings are not in place and the roadway is opened to traffic, DO NOT PASS signs shall be erected to mark the beginning of the sections where passing is prohibited and PASS WITH CARE signs at the beginning of sections where passing is permitted.
- All work zone pavement markings shall be installed in accordance with Item 662, "Work Zone Pavement Markings."

RAISED PAVEMENT MARKERS

- Raised pavement markers are to be placed according to the patterns on BC(12).
- All raised pavement markers used for work zone markings shall meet the requirements of Item 672, "RAISED PAVEMENT MARKERS" and Departmental Material Specification DMS-4200 or DMS-4300.

PREFABRICATED PAVEMENT MARKINGS

- Removable prefabricated pavement markings shall meet the requirements of DMS-8241.
- Non-removable prefabricated pavement markings (foil back) shall meet the requirements of DMS-8240.

MAINTAINING WORK ZONE PAVEMENT MARKINGS

- The Contractor will be responsible for maintaining work zone pavement markings within the work limits.
- Work zone pavement markings shall be inspected in accordance with the frequency and reporting requirements of work zone traffic control device inspections as required by Form 599.
- The markings should provide a visible reference for a minimum distance of 300 feet during normal daylight hours and 160 feet when illuminated by automobile low-beam headlights at night, unless sight distance is restricted by roadway geometrics.
- Markings failing to meet this criteria within the first 30 days after placement shall be replaced at the expense of the Contractor as per Specification Item 662.

REMOVAL OF PAVEMENT MARKINGS

- Pavement markings that are no longer applicable, could create confusion or direct a motorist toward or into the closed portion of the roadway shall be removed or obliterated before the roadway is opened to traffic.
- The above shall not apply to detours in place for less than three days, where flaggers and/or sufficient channelizing devices are used in lieu of markings to outline the detour route.
- Pavement markings shall be removed to the fullest extent possible, so as not to leave a discernable marking. This shall be by any method approved by TxDOT Specification Item 677 for "Eliminating Existing Pavement Markings and Markers".
- The removal of pavement markings may require resurfacing or seal coating portions of the roadway as described in Item 677.
- Subject to the approval of the Engineer, any method that proves to be successful on a particular type pavement may be used.
- Blast cleaning may be used but will not be required unless specifically shown in the plans.
- Over-painting of the markings SHALL NOT BE permitted.
- Removal of raised pavement markers shall be as directed by the Engineer.
- Removal of existing pavement markings and markers will be paid for directly in accordance with Item 677, "ELIMINATING EXISTING PAVEMENT MARKINGS AND MARKERS," unless otherwise stated in the plans.
- Black-out marking tape may be used to cover conflicting existing markings for periods less than two weeks when approved by the Engineer.

Temporary Flexible-Reflective Roadway Marker Tabs

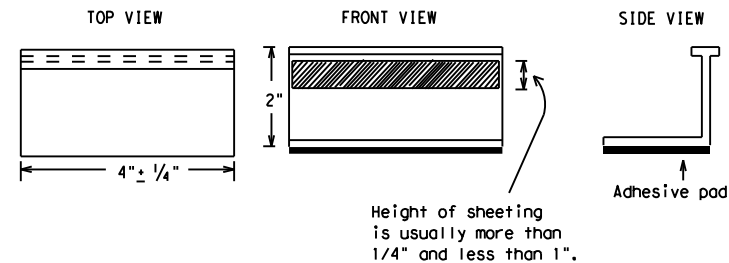

**STAPLES OR NAILS SHALL NOT BE USED TO SECURE
TEMPORARY FLEXIBLE-REFLECTIVE ROADWAY MARKER
TABS TO THE PAVEMENT SURFACE**

- Temporary flexible-reflective roadway marker tabs used as guidemarks shall meet the requirements of DMS-8242.
- Tabs detailed on this sheet are to be inspected and accepted by the Engineer or designated representative. Sampling and testing is not normally required, however at the option of the Engineer, either "A" or "B" below may be imposed to assure quality before placement on the roadway.
 - Select five (5) or more tabs at random from each lot or shipment and submit to the Construction Division, Materials and Pavement Section to determine specification compliance.
 - Select five (5) tabs and perform the following test. Affix five (5) tabs at 24 inch intervals on an asphaltic pavement in a straight line. Using a medium size passenger vehicle or pickup, run over the markers with the front and rear tires at a speed of 35 to 40 miles per hour, four (4) times in each direction. No more than one (1) out of the five (5) reflective surfaces shall be lost or displaced as a result of this test.
- Small design variances may be noted between tab manufacturers.
- See Standard Sheet WZ(STPM) for tab placement on new pavements. See Standard Sheet TCP(7-1) for tab placement on seal coat work.

RAISED PAVEMENT MARKERS USED AS GUIDEMARKS

- Raised pavement markers used as guidemarks shall be from the approved product list, and meet the requirements of DMS-4200.
- All temporary construction raised pavement markers provided on a project shall be of the same manufacturer.
- Adhesive for guidemarks shall be bituminous material hot applied or butyl rubber pad for all surfaces, or thermoplastic for concrete surfaces.

Guidemarks shall be designated as:
 YELLOW - (two amber reflective surfaces with yellow body).
 WHITE - (one silver reflective surface with white body).

DEPARTMENTAL MATERIAL SPECIFICATIONS	
PAVEMENT MARKERS (REFLECTORIZED)	DMS-4200
TRAFFIC BUTTONS	DMS-4300
EPOXY AND ADHESIVES	DMS-6100
BITUMINOUS ADHESIVE FOR PAVEMENT MARKERS	DMS-6130
PERMANENT PREFABRICATED PAVEMENT MARKINGS	DMS-8240
TEMPORARY REMOVABLE, PREFABRICATED PAVEMENT MARKINGS	DMS-8241
TEMPORARY FLEXIBLE, REFLECTIVE ROADWAY MARKER TABS	DMS-8242

A list of prequalified reflective raised pavement markers, non-reflective traffic buttons, roadway marker tabs and other pavement markings can be found at the Material Producer List web address shown on BC(1).

SHEET 11 OF 12



BARRICADE AND CONSTRUCTION PAVEMENT MARKINGS

BC(11)-21

FILE: bc-21.dgn	DN: TxDOT	CK: TxDOT	DW: TxDOT	CR: TxDOT
© TxDOT February 1998	CONT	SECT	JOB	HIGHWAY
REVISIONS		0095	14	033, ETC
2-98	9-07	5-21		IH 20, ETC
1-02	7-13			
11-02	8-14			
	DIST	COUNTY	SHEET NO.	
	DAL	KAUFMAN, ETC	88	

DISCLAIMER: The use of this standard is governed by the "Texas Engineering Practice Act". No warranty of any kind is made by TxDOT for any purpose whatsoever. TxDOT assumes no responsibility for the conversion of this standard to other formats or for incorrect results or damages resulting from its use.
 DATE: 3/17/2023 4:30:17 PM
 FILE: T:\DAL\TRAFM\FY_2023_PS&E\I\H_20\Plan_Set\Standards\non-paf_standards\078 - 089 BC(1) TO (12) - 21.dgn

PAVEMENT MARKING PATTERNS



REFLECTORIZED PAVEMENT MARKINGS - PATTERN A



REFLECTORIZED PAVEMENT MARKINGS - PATTERN B

Pattern A is the TXDOT Standard, however Pattern B may be used if approved by the Engineer. Prefabricated markings may be substituted for reflectORIZED pavement markings.



RAISED PAVEMENT MARKERS - PATTERN A



RAISED PAVEMENT MARKERS - PATTERN B

CENTER LINE & NO-PASSING ZONE BARRIER LINES FOR TWO-LANE, TWO-WAY HIGHWAYS



REFLECTORIZED PAVEMENT MARKINGS

Prefabricated markings may be substituted for reflectORIZED pavement markings.



RAISED PAVEMENT MARKERS

EDGE & LANE LINES FOR DIVIDED HIGHWAY



REFLECTORIZED PAVEMENT MARKINGS

Prefabricated markings may be substituted for reflectORIZED pavement markings.

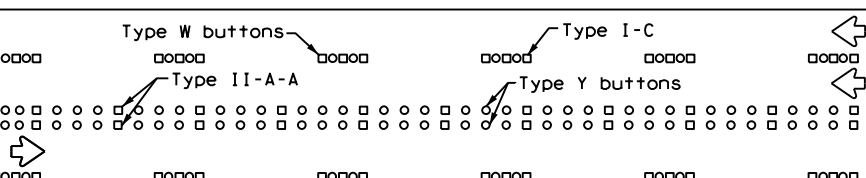

RAISED PAVEMENT MARKERS

LANE & CENTER LINES FOR MULTILANE UNDIVIDED HIGHWAYS

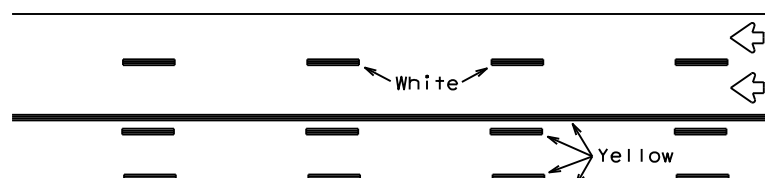

REFLECTORIZED PAVEMENT MARKINGS

Prefabricated markings may be substituted for reflectORIZED pavement markings.

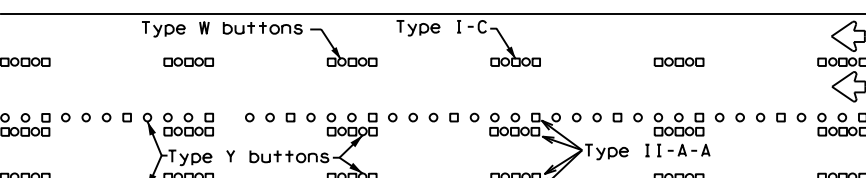

RAISED PAVEMENT MARKERS

TWO-WAY LEFT TURN LANE

STANDARD WORK ZONE PAVEMENT MARKINGS DETAILS



SOLID LINES

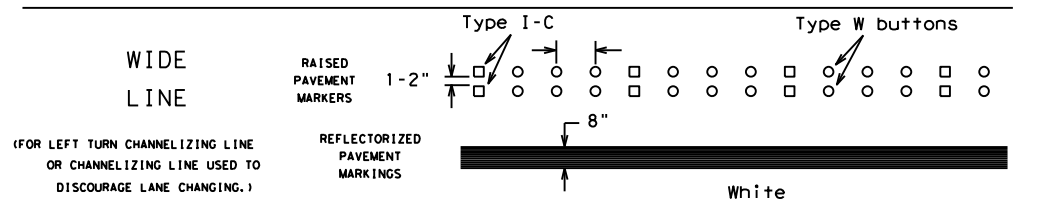
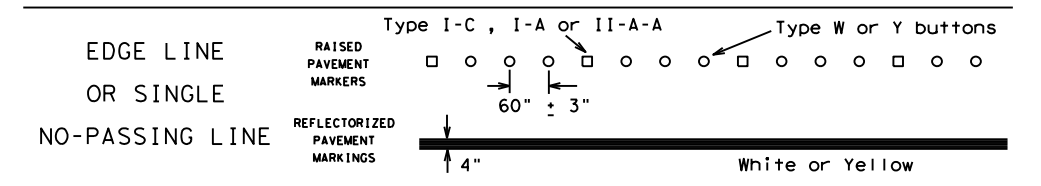

(FOR LEFT TURN CHANNELIZING LINE OR CHANNELIZING LINE USED TO DISCOURAGE LANE CHANGING.)

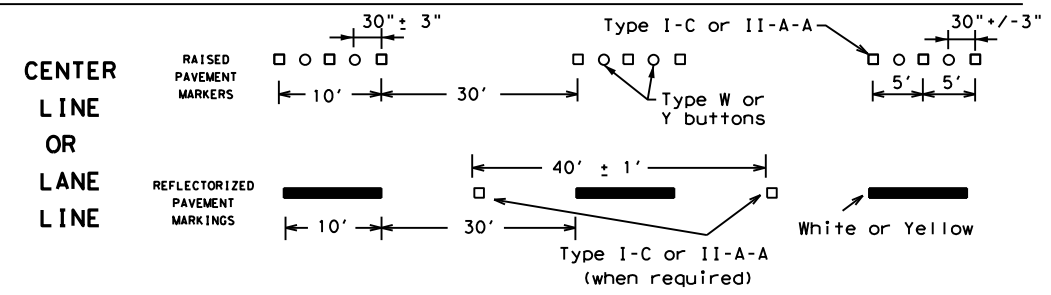

BROKEN LINES

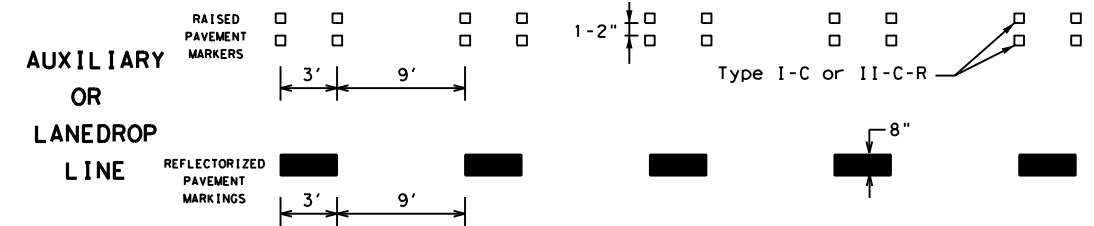

REMOVABLE MARKINGS WITH RAISED PAVEMENT MARKERS

If raised pavement markers are used to supplement REMOVABLE markings, the markers shall be applied to the top of the tape at the approximate mid length of tape used for broken lines or at 20 foot spacing for solid lines. This allows an easier removal of raised pavement markers and tape.



SHEET 12 OF 12



BARRICADE AND CONSTRUCTION PAVEMENT MARKING PATTERNS

BC(12)-21

Raised pavement markers used as standard pavement markings shall be from the approved products list and meet the requirements of Item 672 "RAISED PAVEMENT MARKERS."

FILE: bc-21.dgn	DN: TxDOT	CK: TxDOT	OW: TxDOT	CR: TxDOT
©TxDOT February 1998	CONT	SECT	JOB	HIGHWAY
REVISIONS	0095	14	033, ETC	IH 20, ETC
1-97 9-07 5-21	DIST	COUNTY	SHEET NO.	
2-98 7-13	DAL	KAUFMAN, ETC	89	
11-02 8-14				

DISCLAIMER: The use of this standard is governed by the "Texas Engineering Practice Act". No warranty of any kind is made by TXDOT for any purpose whatsoever. TXDOT assumes no responsibility for the conversion of this standard to other formats or for incorrect results or damages resulting from its use.

DATE: 3/17/2023 4:30:19 PM
FILE: I:\DAL\TRAFFIC\2023 PS&E\I.H. 20\Plan Set\Standards\non-paf_standards\078 - 089 BC(12) TO (12) - 21.dgn

DISCLAIMER: The use of this standard is governed by the "Texas Engineering Practice Act". No warranty of any kind is made by TxDOT for any purpose whatsoever. TxDOT assumes no responsibility for the conversion of units or for the use of this standard in any other format or for incorrect results or damages resulting from its use.

DATE: 3/1/2023 4:31:52 PM
 FILE: T:\DAL\TRAFFIC PLAN\20\N\Plan_Set\Standards\non-paf_standards\050\Traffic_Control\TCP (1-5).dgn

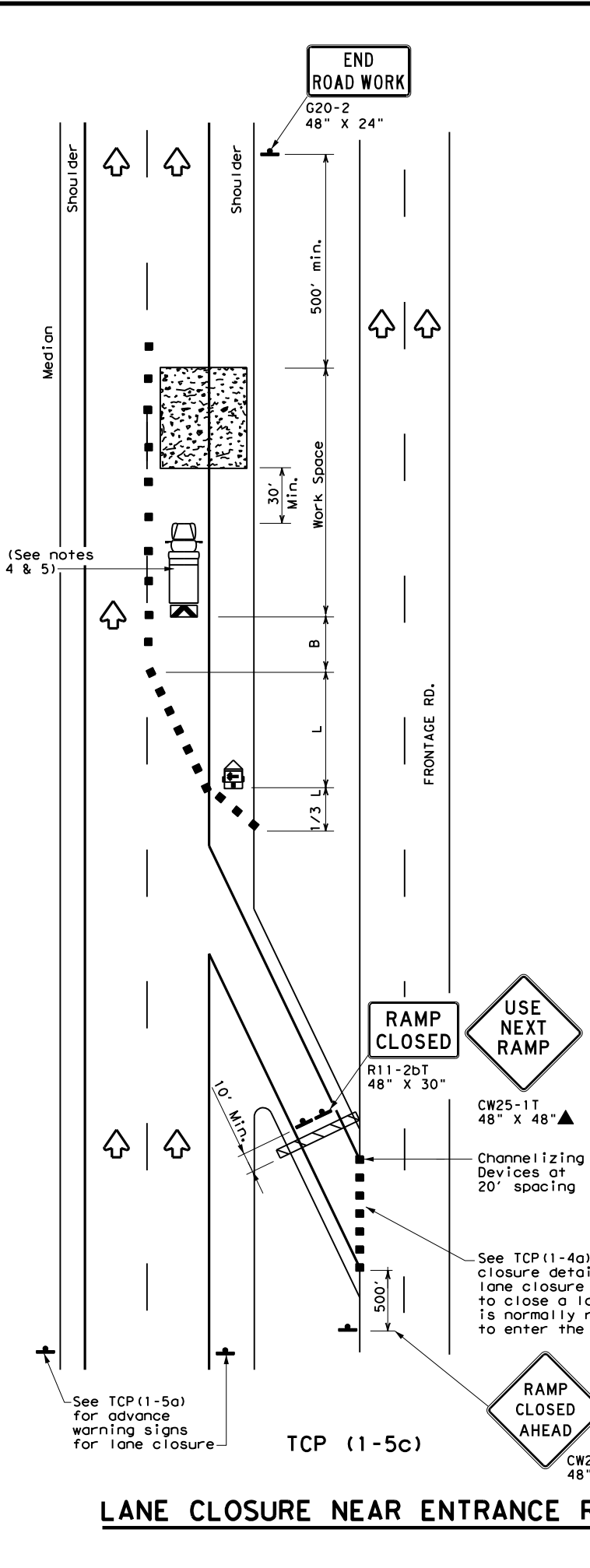
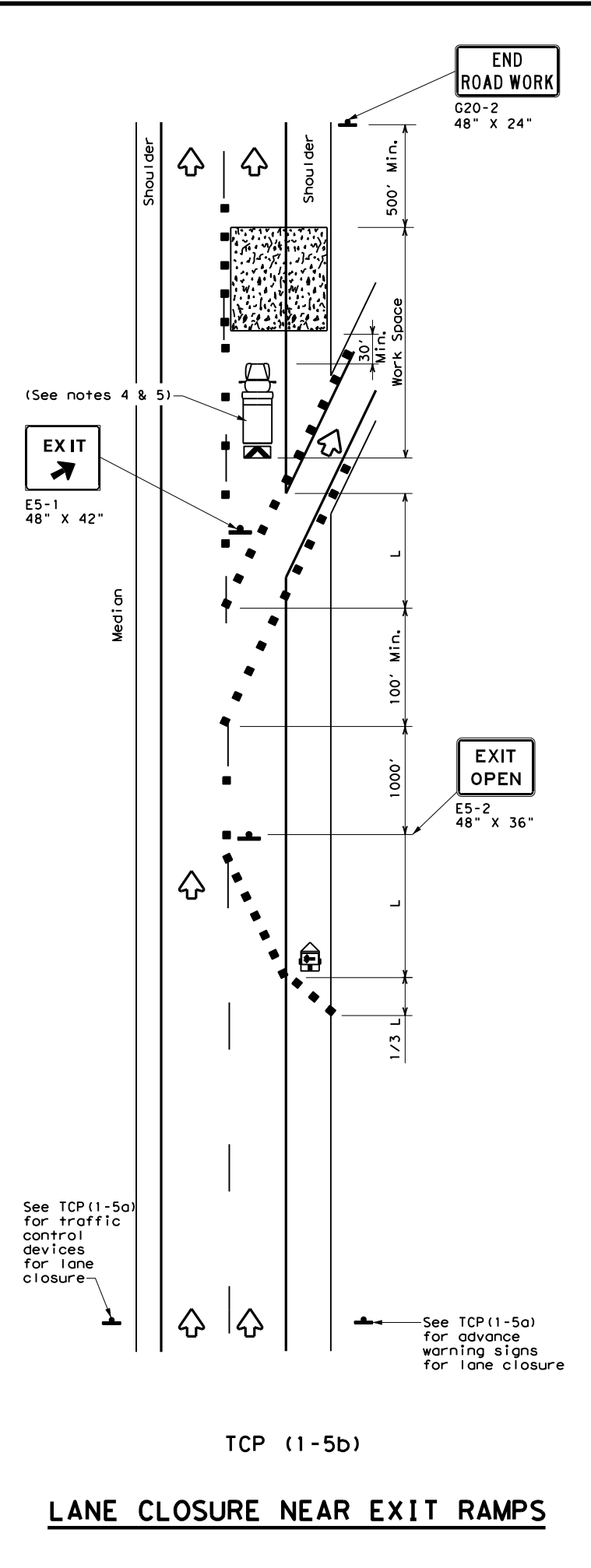
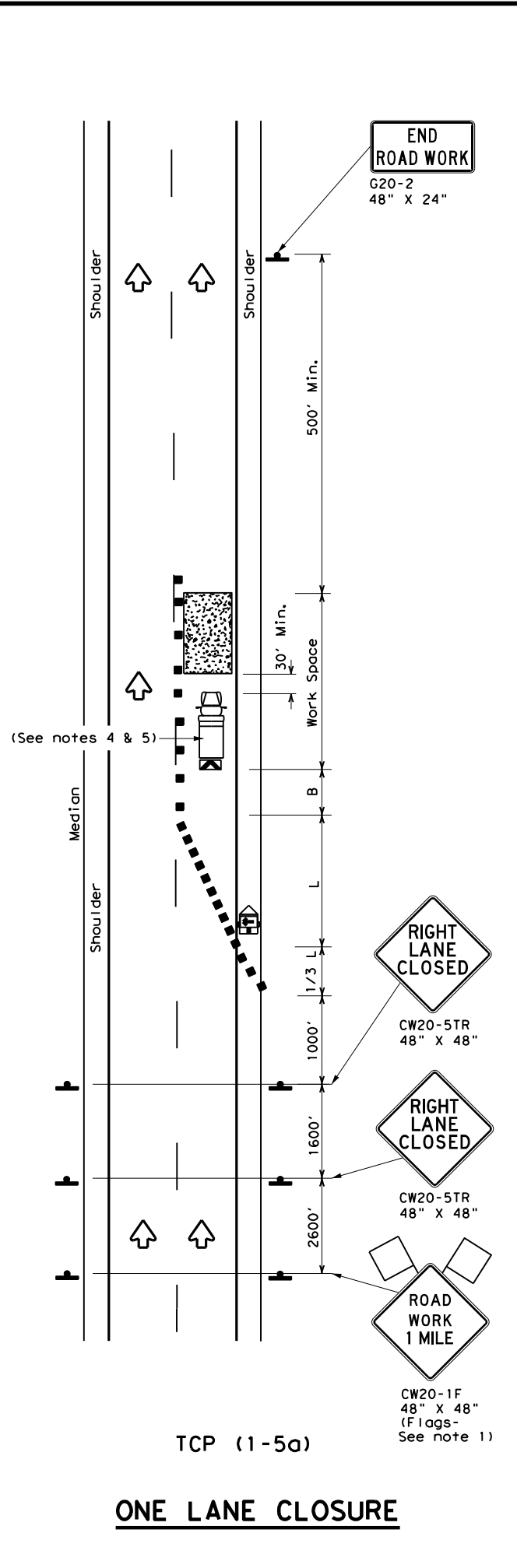

LEGEND			
	Type 3 Barricade		Channelizing Devices
	Heavy Work Vehicle		Truck Mounted Attenuator (TMA)
	Trailer Mounted Flashing Arrow Board		Portable Changeable Message Sign (PCMS)
	Sign		Traffic Flow
	Flag		Flagger

Posted Speed *	Formula	Minimum Desirable Taper Lengths **			Suggested Maximum Spacing of Channelizing Devices		Minimum Sign Spacing "X" Distance	Suggested Longitudinal Buffer Space "B"
		10' Offset	11' Offset	12' Offset	On a Taper	On a Tangent		
30	$L = \frac{WS^2}{60}$	150'	165'	180'	30'	60'	120'	90'
35		205'	225'	245'	35'	70'	160'	120'
40		265'	295'	320'	40'	80'	240'	155'
45	L = WS	450'	495'	540'	45'	90'	320'	195'
50		500'	550'	600'	50'	100'	400'	240'
55		550'	605'	660'	55'	110'	500'	295'
60		600'	660'	720'	60'	120'	600'	350'
65		650'	715'	780'	65'	130'	700'	410'
70		700'	770'	840'	70'	140'	800'	475'
75		750'	825'	900'	75'	150'	900'	540'

* Conventional Roads Only
 ** Taper lengths have been rounded off.
 L=Length of Taper (FT) W=Width of Offset (FT) S=Posted Speed (MPH)

TYPICAL USAGE				
MOBILE	SHORT DURATION	SHORT TERM STATIONARY	INTERMEDIATE TERM STATIONARY	LONG TERM STATIONARY
		✓		

- GENERAL NOTES**
- Flags attached to signs where shown, are REQUIRED.
 - All traffic control devices illustrated are REQUIRED, except those denoted with the triangle symbol may be omitted when stated elsewhere in the plans, or for routine maintenance work, when approved by the Engineer.
 - Channelizing devices used to close lanes may be supplemented with the Chevron Alignment Sign placed on every other channelizing device. Chevrons may be attached to plastic drums as per BC Standards.
 - Shadow Vehicle with TMA and high intensity rotating, flashing, oscillating or strobe lights. A Shadow Vehicle with a TMA should be used anytime it can be positioned 30 to 100 feet in advance of the area of crew exposure without adversely affecting the performance or quality of the work. If workers are no longer present but road or work conditions require the traffic control to remain in place, Type 3 Barricades or other channelizing devices may be substituted for the Shadow Vehicle and TMA.
 - Additional Shadow Vehicles with TMAs may be positioned in each closed lane, on the shoulder or off the paved surface, next to those shown in order to protect a wider work space.

Texas Department of Transportation
 Traffic Operations Division Standard

**TRAFFIC CONTROL PLAN
 LANE CLOSURES FOR
 DIVIDED HIGHWAYS**

TCP (1-5) - 18

FILE: tcp1-5-18.dgn	DN:	CK:	DW:	CK:
© TxDOT February 2012	CONT	SECT	JOB	HIGHWAY
2-18	REVISIONS	0095 14	033, ETC	IH 20, ETC
	DIST	COUNTY	SHEET NO.	
	DAL	KAUFMAN, ETC	90	

DATE: 3/1/2023 4:31:52 PM
 FILE: T:\DAL\TRAFFIC\2023 PS&E\I\H 20\Plan Set\Standards\non-paf_standards.dwg
 The use of this standard is governed by the "Texas Engineering Practice Act". No warranty of any kind is made by TxDOT for any purpose whatsoever. TxDOT assumes no responsibility for the conversion of this standard to other formats or for incorrect results or damages resulting from its use.

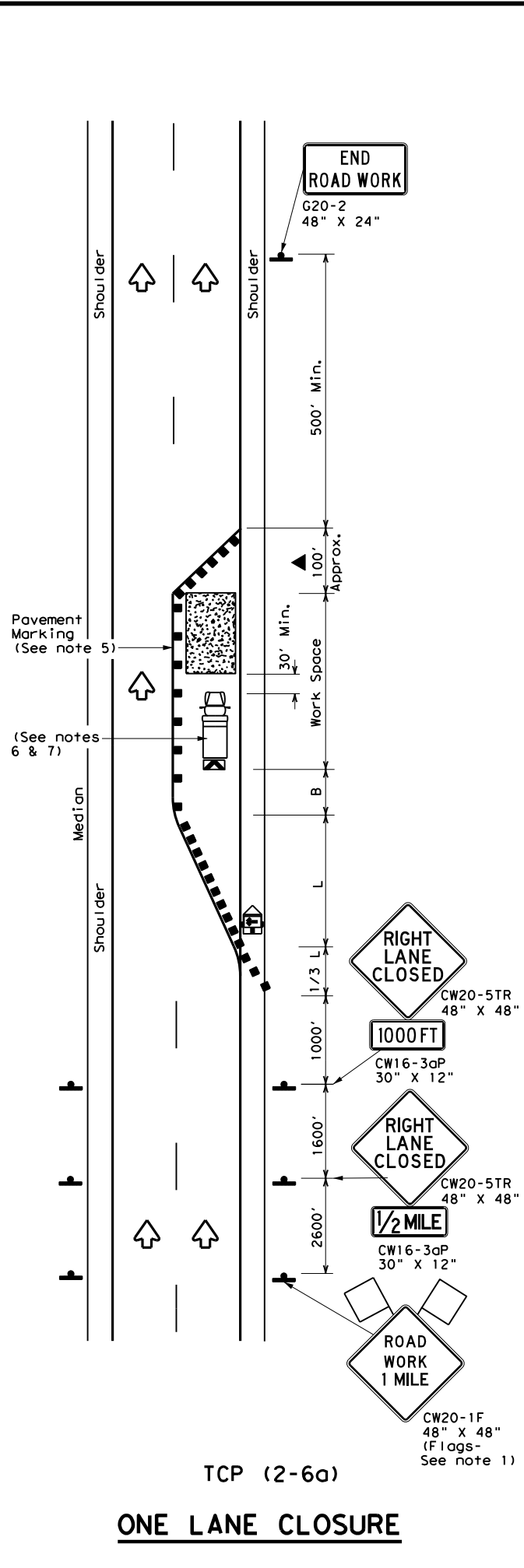

TCP (2-6a)
ONE LANE CLOSURE

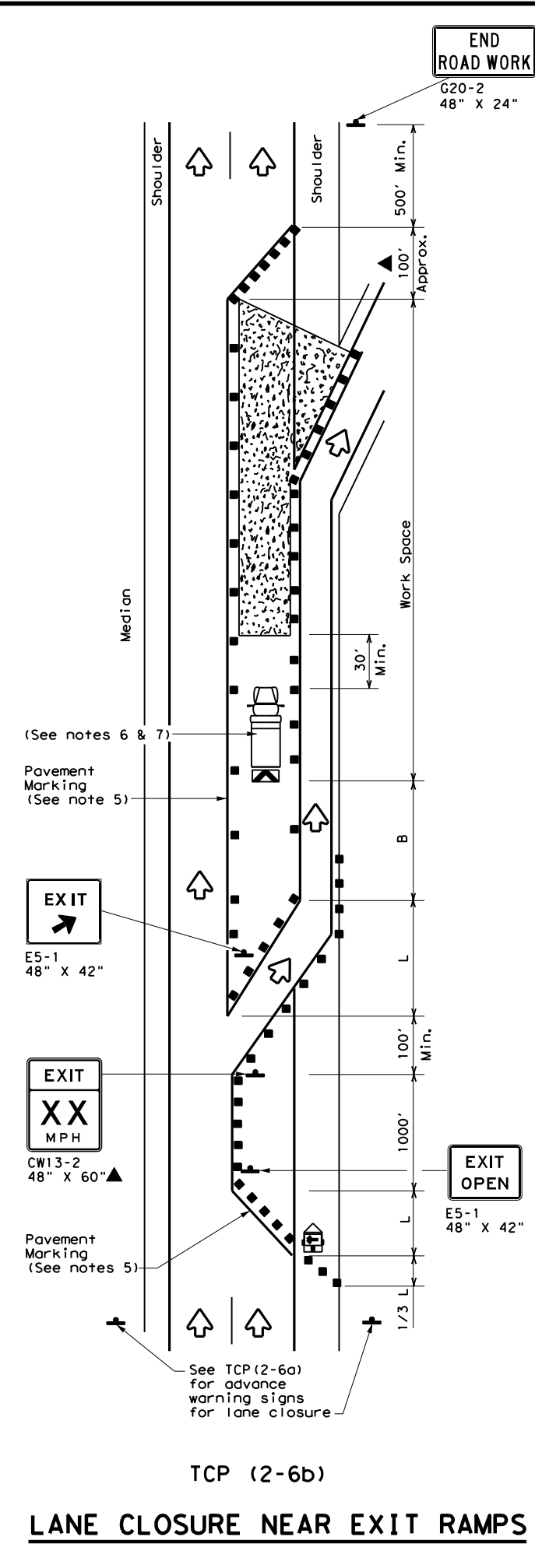

TCP (2-6b)
LANE CLOSURE NEAR EXIT RAMP

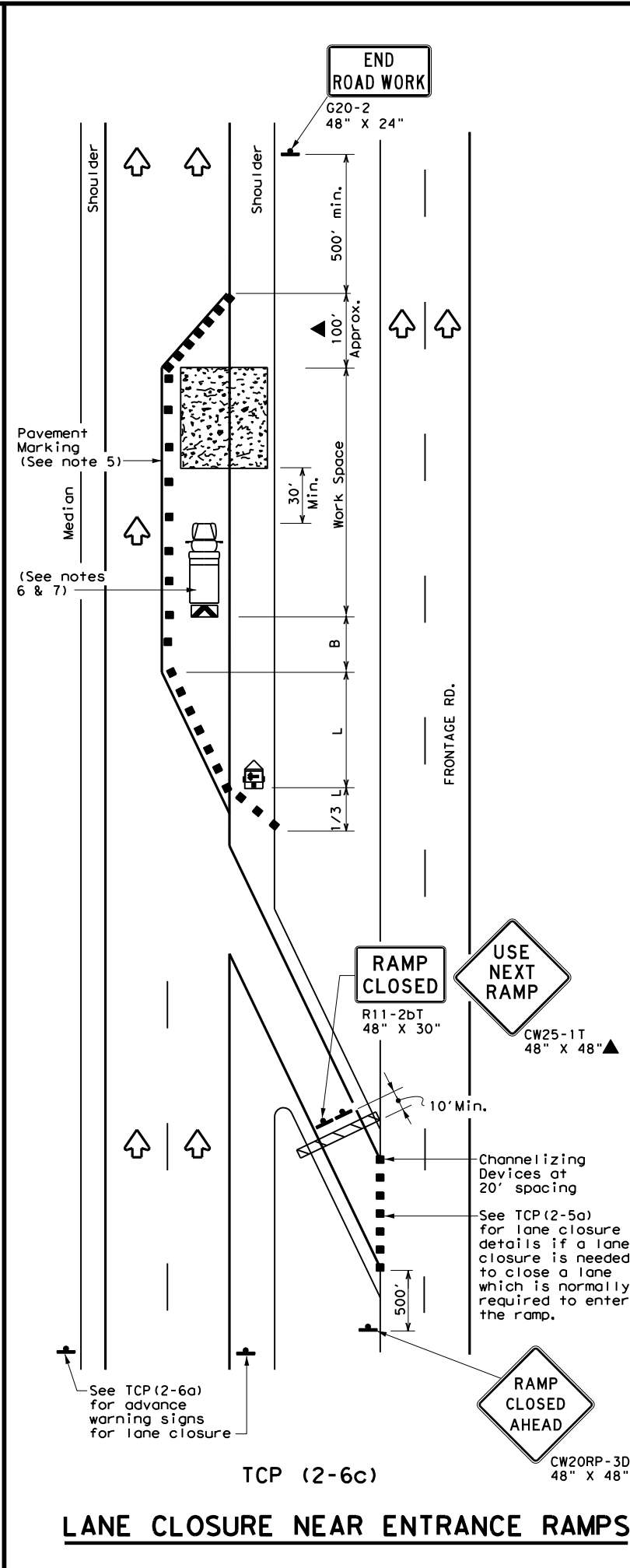

TCP (2-6c)
LANE CLOSURE NEAR ENTRANCE RAMP

LEGEND			
	Type 3 Barricade		Channelizing Devices
	Heavy Work Vehicle		Truck Mounted Attenuator (TMA)
	Trailer Mounted Flashing Arrow Board		Portable Changeable Message Sign (PCMS)
	Sign		Traffic Flow
	Flag		Flagger

Posted Speed *	Formula	Minimum Desirable Taper Lengths **			Suggested Maximum Spacing of Channelizing Devices		Minimum Sign Spacing "X" Distance	Suggested Longitudinal Buffer Space "B"
		10' Offset	11' Offset	12' Offset	On a Taper	On a Tangent		
30	$L = \frac{WS^2}{60}$	150'	165'	180'	30'	60'	120'	90'
35		205'	225'	245'	35'	70'	160'	120'
40		265'	295'	320'	40'	80'	240'	155'
45	L = WS	450'	495'	540'	45'	90'	320'	195'
50		500'	550'	600'	50'	100'	400'	240'
55		550'	605'	660'	55'	110'	500'	295'
60		600'	660'	720'	60'	120'	600'	350'
65		650'	715'	780'	65'	130'	700'	410'
70		700'	770'	840'	70'	140'	800'	475'
75		750'	825'	900'	75'	150'	900'	540'

* Conventional Roads Only
 ** Taper lengths have been rounded off.
 L=Length of Taper (FT) W=Width of Offset (FT) S=Posted Speed (MPH)

TYPICAL USAGE				
MOBILE	SHORT DURATION	SHORT TERM STATIONARY	INTERMEDIATE TERM STATIONARY	LONG TERM STATIONARY
			✓	✓

- GENERAL NOTES**
- Flags attached to signs where shown, are REQUIRED.
 - All traffic control devices illustrated are REQUIRED, except those denoted with the triangle symbol may be omitted when stated elsewhere in the plans, or for routine maintenance work, when approved by the Engineer.
 - Channelizing devices used to close lanes may be supplemented with the Chevron Alignment Sign placed on every other channelizing device. Chevrons may be attached to plastic drums as per BC Standards.
 - Channelizing devices used along the work space or along tangent sections may be supplemented with vertical panels (VP) placed on every other channelizing device. If night time conditions make it difficult to see at least two VPs, the VPs may be placed on each channelizing device.
 - The placement of pavement markings may be omitted on intermediate-term stationary work zones with the approval of the Engineer.
 - Shadow Vehicle with TMA and high intensity rotating, flashing, oscillating or strobe lights. A Shadow Vehicle with a TMA should be used anytime it can be positioned 30 to 100 feet in advance of the area of crew exposure without adversely affecting the performance or quality of the work. If workers are no longer present but road or work conditions require the traffic control to remain in place, Type 3 Barricades or other channelizing devices may be substituted for the Shadow Vehicle and TMA.
 - Additional Shadow Vehicles with TMAs may be positioned in each closed lane, on the shoulder or off the paved surface, next to those shown in order to protect a wider work space.

Texas Department of Transportation
 Traffic Operations Division Standard

TRAFFIC CONTROL PLAN
LANE CLOSURES ON
DIVIDED HIGHWAYS
TCP (2-6) - 18

FILE: tcp2-6-18.dgn	DW: _____	CK: _____	CK: _____
© TxDOT December 1985	CONT: _____	SECT: _____	HIGHWAY: _____
REVISIONS	0095 14	JOB: 033, ETC	IH 20, ETC
2-94 4-98		DIST: _____	COUNTY: _____
8-95 2-12		DAL: KAUFMAN, ETC	SHEET NO. 91
1-97 2-18			

DATE: 3/1/2023 4:31:53 PM
 FILE: T:\DAL\TRAFFIC\2023 PS&E\1H 20\Plan Set\Standards\non-paf_standards\02 Traffic Signage.dwg
 The use of this standard is governed by the "Texas Engineering Practice Act". No warranty of any kind is made by TxDOT for any purpose whatsoever. TxDOT assumes no responsibility for the conversion of this standard to other formats or for incorrect results or damages resulting from its use.

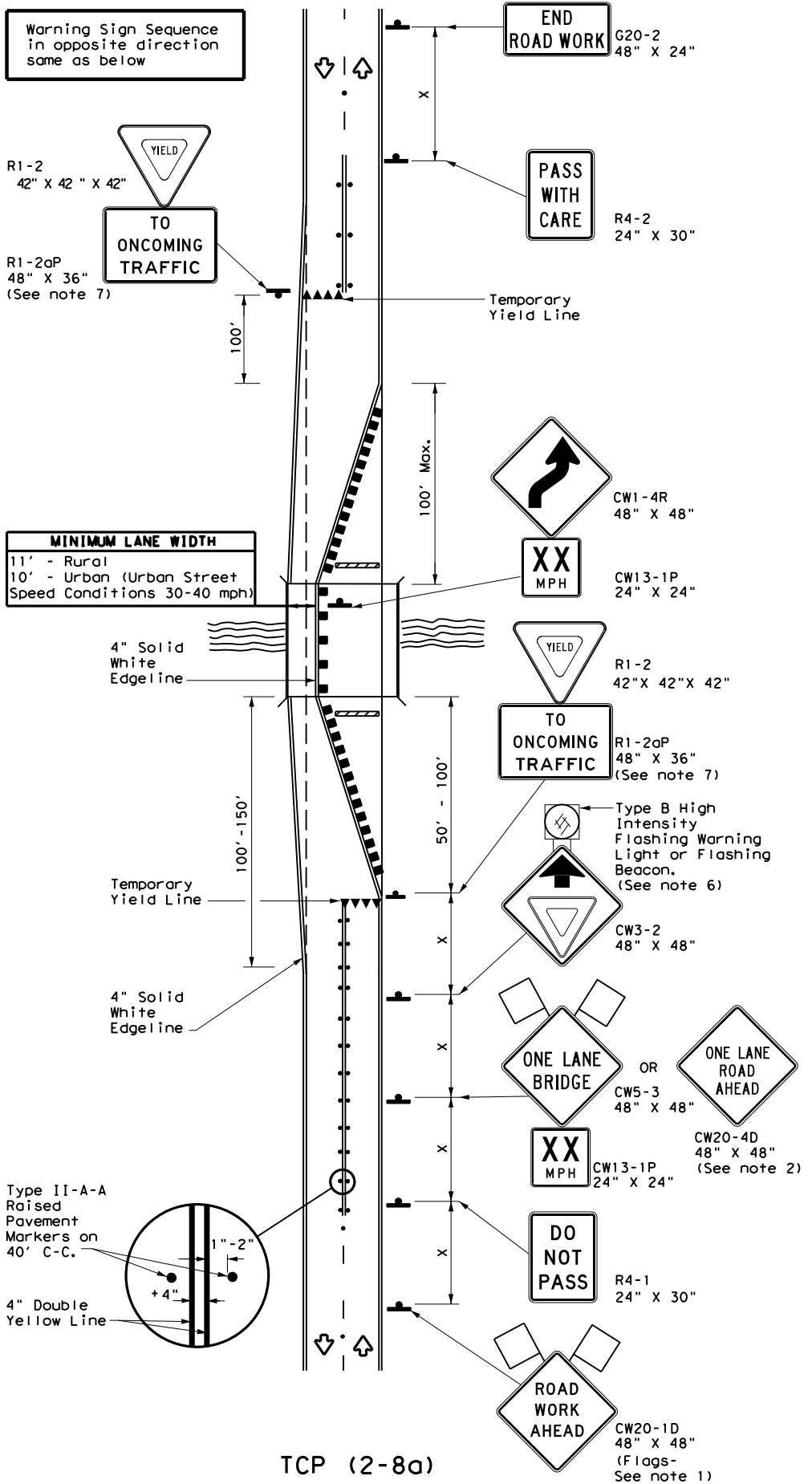

TCP (2-8a)
ONE LANE TWO-WAY
TRAFFIC CONTROL WITH YIELD SIGNS
 (Less Than 2000 ADT-See Note 5)

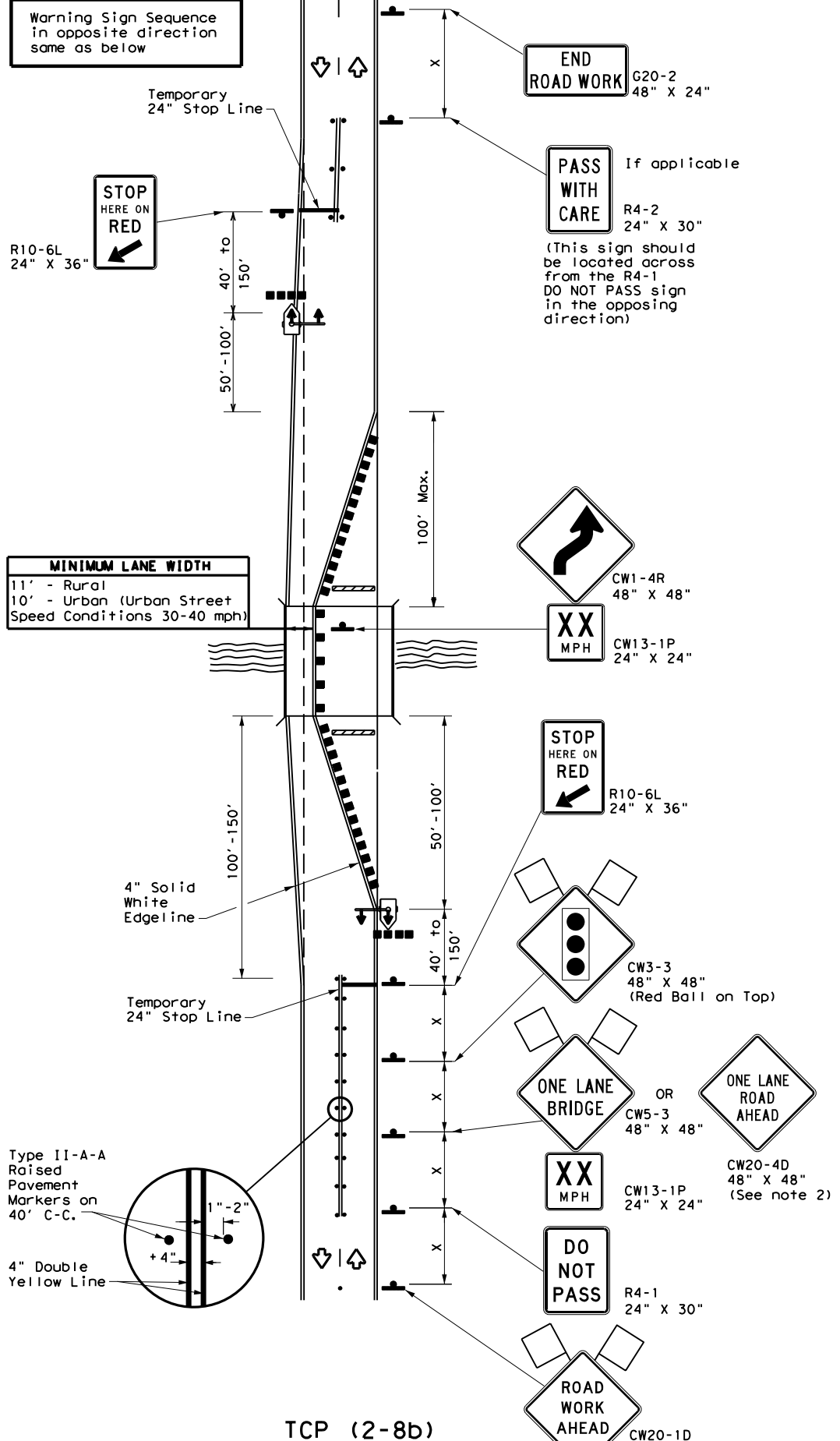

TCP (2-8b)
ONE LANE TWO-WAY
TRAFFIC CONTROL WITH TRAFFIC SIGNAL

LEGEND			
	Type 3 Barricade		Channelizing Devices
	Sign		Traffic Flow
	Flag		Flagger
	Raised Pavement Markers Ty II-AA		Temporary or Portable Traffic Signal

Posted Speed *	Formula	Minimum Desirable Taper Lengths **			Suggested Maximum Spacing of Channelizing Devices		Minimum Sign Spacing "X" Distance	Suggested Longitudinal Buffer Space "B"	Stopping Sight Distance
		10' Offset	11' Offset	12' Offset	On a Taper	On a Tangent			
30	L = WS ² / 60	150'	165'	180'	30'	60'	120'	90'	200'
35		205'	225'	245'	35'	70'	160'	120'	250'
40		265'	295'	320'	40'	80'	240'	155'	305'
45	L = WS	450'	495'	540'	45'	90'	320'	195'	360'
50		500'	550'	600'	50'	100'	400'	240'	425'
55		550'	605'	660'	55'	110'	500'	295'	495'
60	L = WS	600'	660'	720'	60'	120'	600'	350'	570'
65		650'	715'	780'	65'	130'	700'	410'	645'
70		700'	770'	840'	70'	140'	800'	475'	730'
75	L = WS	750'	825'	900'	75'	150'	900'	540'	820'

* Conventional Roads Only
 ** Taper lengths have been rounded off.
 L=Length of Taper (FT) W=Width of Offset (FT) S=Posted Speed (MPH)

TYPICAL USAGE				
MOBILE	SHORT DURATION	SHORT TERM STATIONARY	INTERMEDIATE TERM STATIONARY	LONG TERM STATIONARY
			✓	✓

- GENERAL NOTES**
- Flags attached to signs where shown are REQUIRED.
 - When this TCP is used at a location which does not involve a bridge, a 48" x 48" CW20-4D "ONE LANE ROAD AHEAD" signs should be used in lieu of the CW5-3 "ONE LANE BRIDGE" signs. The CW13-1P Advisory Speed Plaque is required with either warning sign.
 - Raised pavement markers shall be placed 40 feet c-c on centerline between DO NOT PASS signs and stop or yield lines.
 - For intermediate term situations, when it is not feasible to remove and restore pavement markings, the channelization must be made dominant by using a very close spacing. This is especially important in locations of conflicting information, such as where traffic is directed over a double yellow centerline. In such locations a maximum channelizing device spacing of 20 feet is recommended. The 20 foot channelizing device spacing recommendation is intended for the area of conflicting information and not the entire work zone.
- TCP (2-8a)**
- Traffic control by CW3-2 "YIELD AHEAD" symbol signs for one lane two-way traffic control operations should be limited to work spaces less than 400 feet long and roadways with less than 2000 ADT. Otherwise, portable traffic signals should be used.
 - If power is available, a flashing beacon should be attached to the CW3-2 "YIELD AHEAD" symbol sign for emphasis.
 - The R1-2 "YIELD" and R1-2aP "TO ONCOMING TRAFFIC" signs and other regulatory signs shall be installed at 7 foot minimum mounting height.
- TCP (2-8b)**
- A list of approved Portable Traffic Signals can be found in the "Compliant Work Zone Traffic Control Devices" list.
 - Portable traffic signals should be located to provide adequate stopping sight distance for approaching motorist (See table above).

Texas Department of Transportation
Traffic Operations Division Standard

TRAFFIC CONTROL PLAN LONG TERM ONE-LANE TWO-WAY CONTROL

TCP (2-8) - 18

FILE: tcp2-8-18.dgn	DN:	CK:	DW:	CK:
© TxDOT December 1985	CONT	SECT	JOB	HIGHWAY
REVISIONS	0095 14	033, ETC	IH 20, ETC	
8-95 3-03	DIST	COUNTY	SHEET NO.	
1-97 2-12	DAL	KAUFMAN, ETC	92	
4-98 2-18				

DISCLAIMER: The use of this standard is governed by the "Texas Engineering Practice Act". No warranty of any kind is made by TxDOT for any purpose whatsoever. TxDOT assumes no responsibility for the conversion of any information into any other format or for incorrect results or damages resulting from its use.

DATE: 3/1/2023 4:31:54 PM
 FILE: T:\DAL\TRAFFIC\2023 PS&E\1H 20\Plan Set\Standards\non-paf_standards\033\Traffic\033.dwg

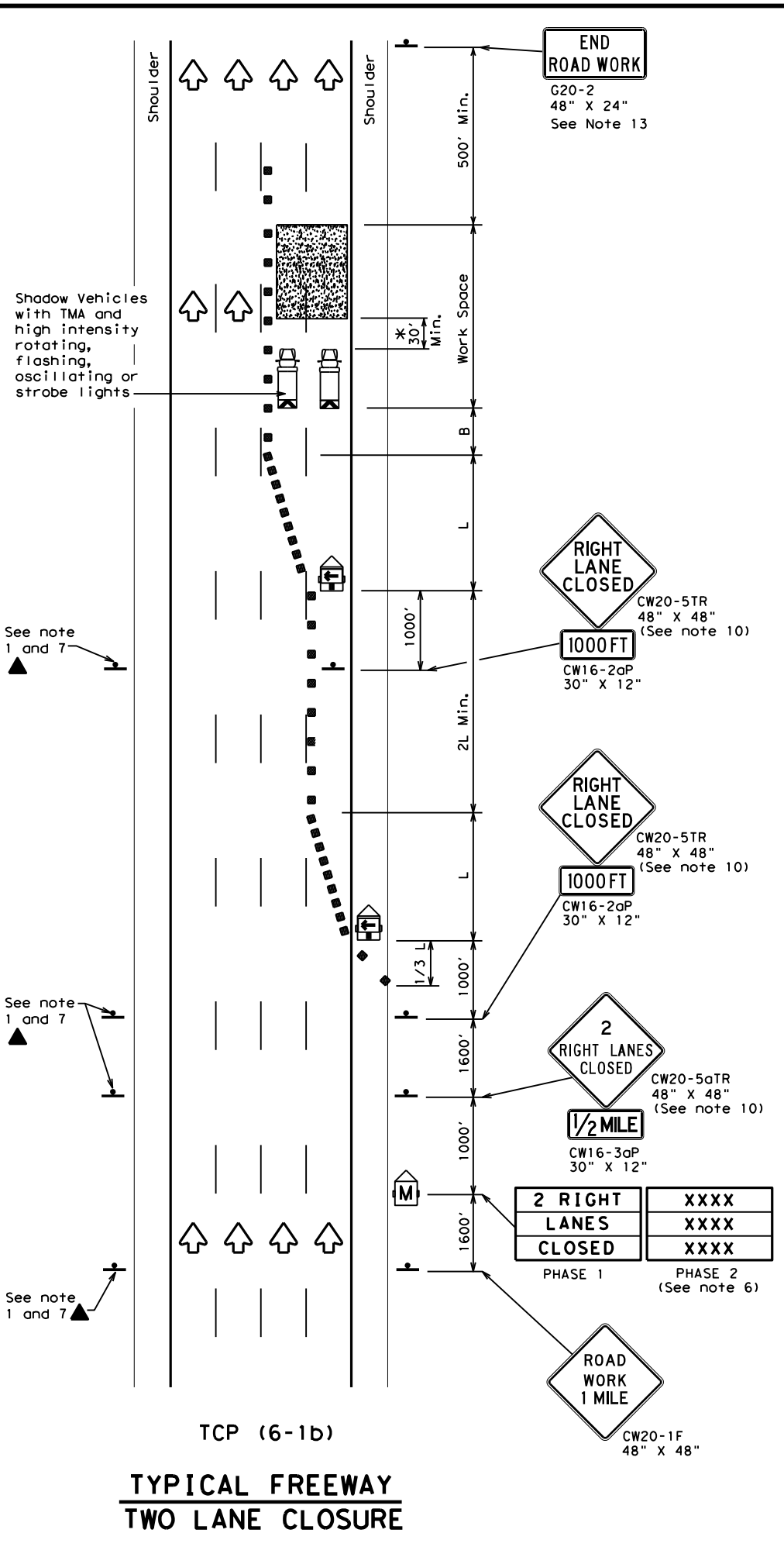
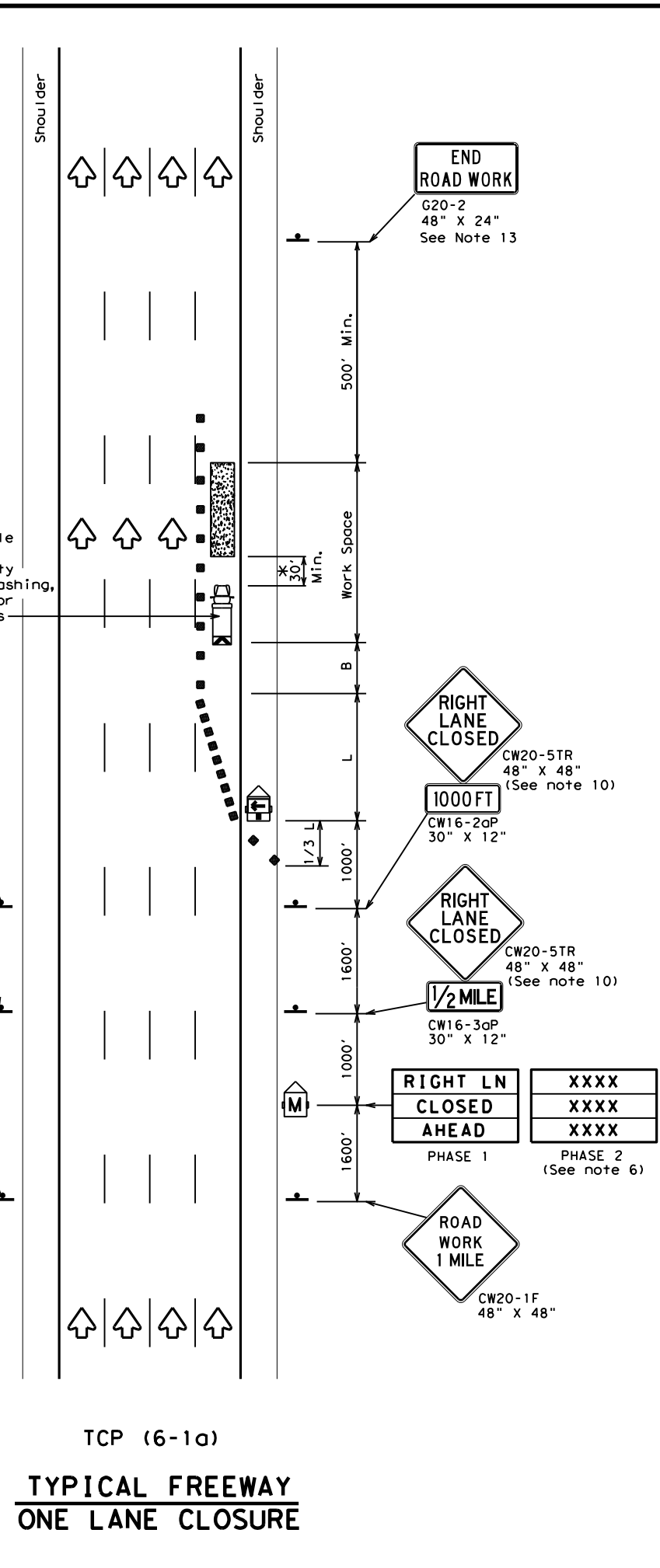

LEGEND

	Type 3 Barricade		Channelizing Devices
	Heavy Work Vehicle		Truck Mounted Attenuator (TMA)
	Trailer Mounted Flashing Arrow Board		Portable Changeable Message Sign (PCMS)
	Sign		Traffic Flow
	Flag		Flagger

Posted Speed	Formula	Minimum Desirable Taper Lengths "L"			Suggested Maximum Spacing of Channelizing Devices		Suggested Longitudinal Buffer Space "B"
		10' Offset	11' Offset	12' Offset	On a Taper	On a Tangent	
45	L = WS	450'	495'	540'	45'	90'	195'
50		500'	550'	600'	50'	100'	240'
55		550'	605'	660'	55'	110'	295'
60		600'	660'	720'	60'	120'	350'
65		650'	715'	780'	65'	130'	410'
70		700'	770'	840'	70'	140'	475'
75		750'	825'	900'	75'	150'	540'
80	800'	880'	960'	80'	160'	615'	

** Taper lengths have been rounded off.
 L=Length of Taper (FT) W=Width of Offset (FT) S=Posted Speed (MPH)

TYPICAL USAGE

MOBILE	SHORT DURATION	SHORT TERM STATIONARY	INTERMEDIATE TERM STATIONARY	LONG TERM STATIONARY
	✓	✓	✓	

GENERAL NOTES

- All traffic control devices illustrated are REQUIRED. Devices denoted with the triangle symbol may be omitted when stated elsewhere in the plans.
- Drums or 42" cones are the typical channelizing devices. For Intermediate Term Stationary work, drums shall be used on tapers with drums or 42" cones used on tangent sections. Other channelizing devices may be used as directed by the Engineer.
- All construction signs and barricades placed during any phase of work shall remain in place until removal is approved by the Engineer.
- The Engineer may direct the Contractor to furnish additional signs and barricades as required to maintain traffic flow, detours and motorist safety during construction.
- Static message boards or changeable message signs stating the date and duration of ramp or freeway lane closures shall be placed a minimum of seven (7) calendar days in advance of the actual closure.
- Phase 2 of the PCMS message should include appropriate information formatted as shown on BC(6), such as "MERGE LEFT," recommended advisory speed, delay information, or other specific warnings.
- Duplicate construction warning signs should be erected on the medians side of freeways where median width will permit and traffic volume justifies the signing.
- The number of closed lanes may be increased provided the spacing of traffic control devices, taper lengths and tangent lengths meet the requirements of the TMUTCD.
- Warning signs for intermediate term stationary work should be mounted at 7' to the bottom of the sign.
- Warning signs shown shall be appropriately altered for left lane closures. When signs are mounted at 1' height for short term stationary or short duration work, sign versions shown in the SHSD for Texas with distances on the sign face rather than mounted on a plaque below the sign may be used.
- When possible, PCMS units should be located in advance of the last available exit ramp prior to the lane closure to allow motorists an alternate route. They may also be relocated to improve advance warning in case of unanticipated queuing or congestion.
- For Intermediate Term Stationary work at night, floodlights should be used to illuminate the work area and equipment crossings. Floodlights shall not produce a disabling glare condition for road users or workers.
- The END ROAD WORK (G20-2) sign may be omitted when it conflicts with G20-2 signs already in place on the project.

* A shadow vehicle equipped with a Truck Mounted Attenuator is typically required. A shadow vehicle equipped with a TMA shall be used if it can be positioned 30' to 100' in advance of the area of crew exposure without adversely affecting the work performance.



**TRAFFIC CONTROL PLAN
 FREEWAY LANE CLOSURES**

TCP (6-1) - 12

FILE:	tcp6-1.dgn	DN:	TxDOT	CR:	TxDOT	OW:	TxDOT	CK:	TxDOT
© TxDOT	February 1998	CONT	SECT	JOB	HIGHWAY				
8-12	REVISIONS	0095	14	033, ETC	IH 20, ETC				
	DIST	COUNTY	SHEET NO.						
	DAL	KAUFMAN, ETC	93						

DISCLAIMER: The use of this standard is governed by the "Texas Engineering Practice Act". No warranty of any kind is made by TxDOT for any purpose whatsoever. TxDOT assumes no responsibility for the conversion of this standard to other formats or for incorrect results or damages resulting from its use.

DATE: 3/1/2023 4:31:54 PM
 FILE: T:\DAL\TRAFFIC\2023 PS&E\I\H_20\Plan_Set\Standards\non-paf_standards\034\Traffic\TCP (6-2).dgn

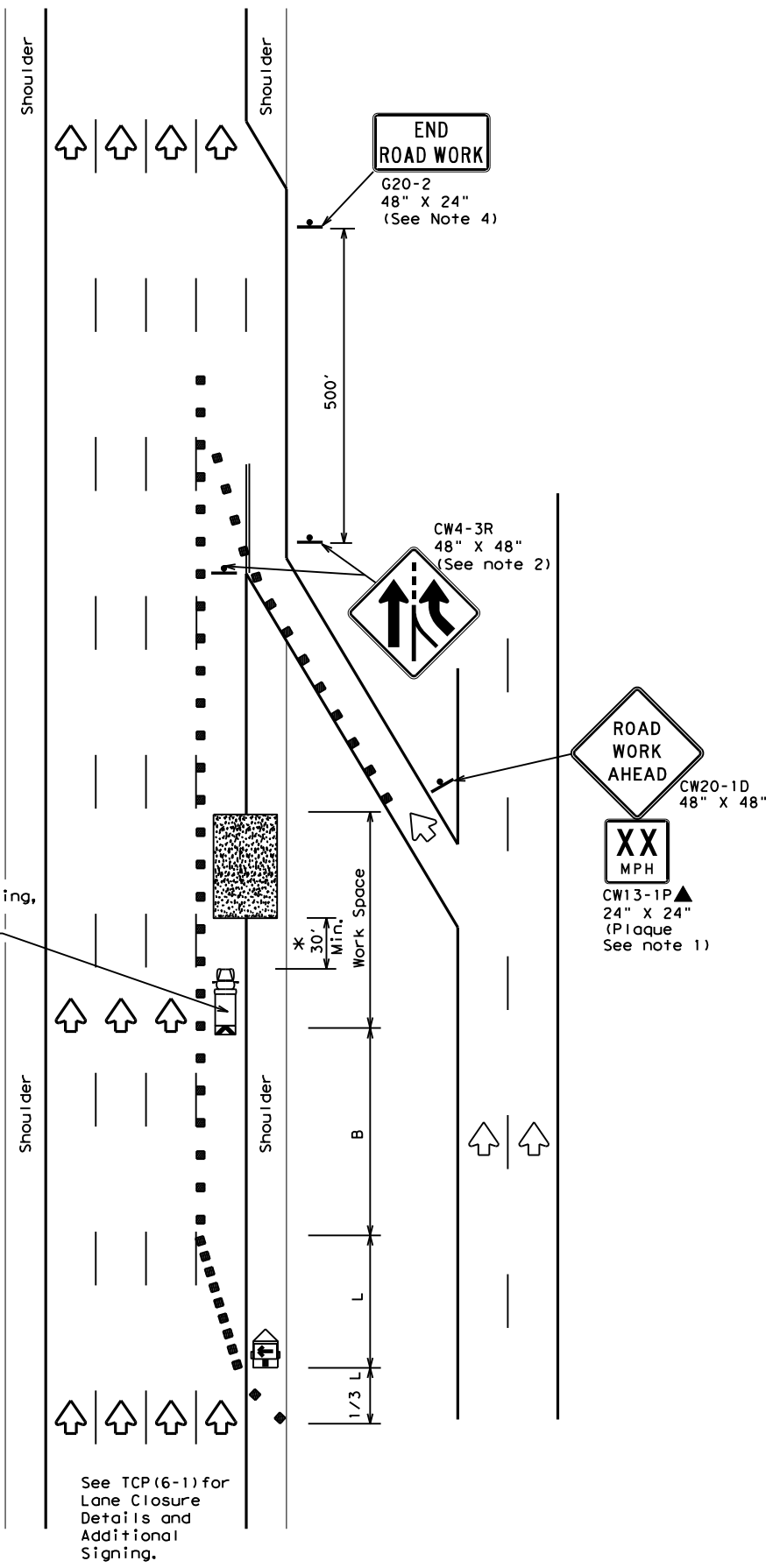

TCP (6-2a)
ENTRANCE RAMP OPEN
WORK WITHIN 500' OF RAMP

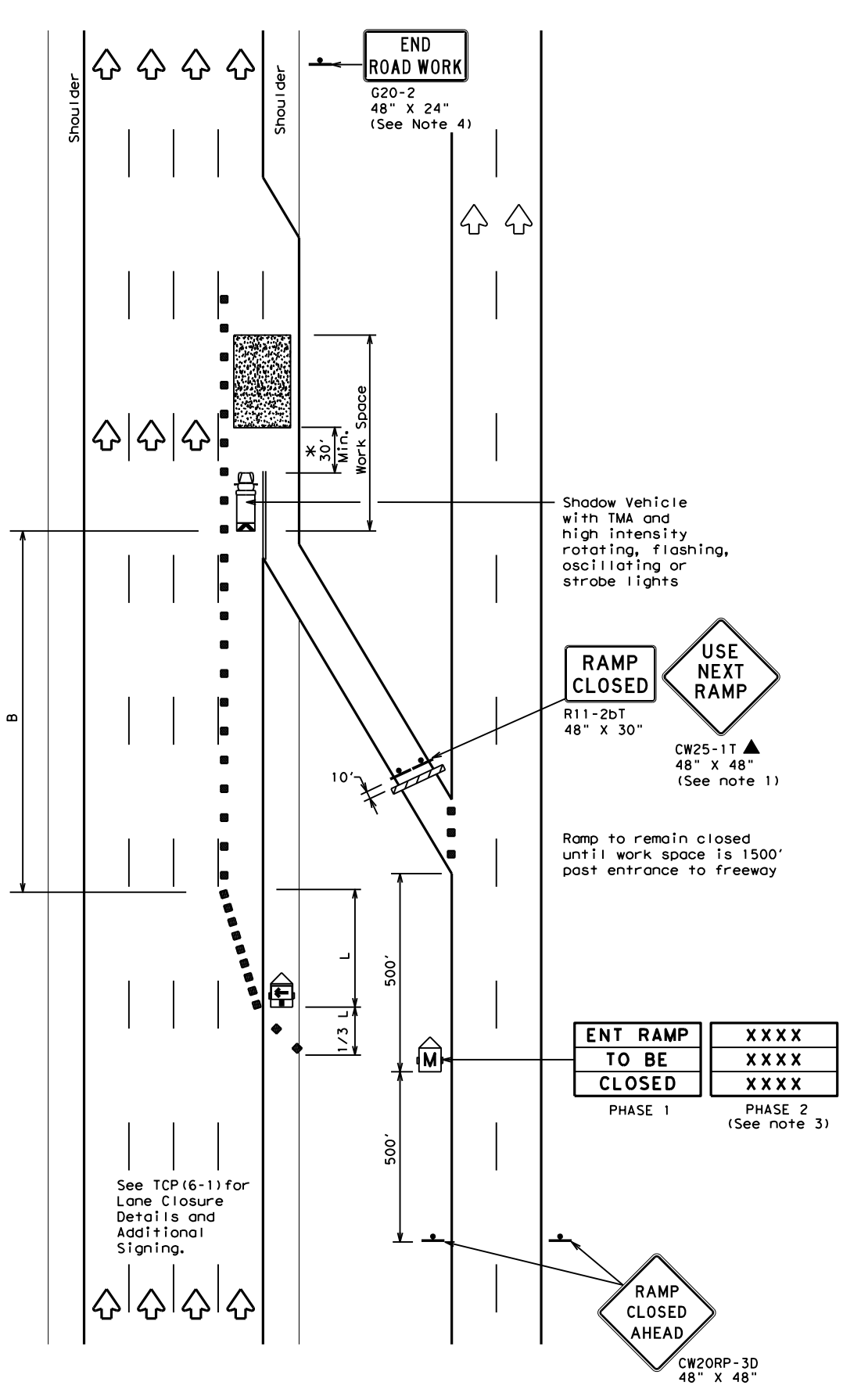

TCP (6-2b)
ENTRANCE RAMP CLOSED

LEGEND			
	Type 3 Barricade		Channelizing Devices
	Heavy Work Vehicle		Truck Mounted Attenuator (TMA)
	Trailer Mounted Flashing Arrow Board		Portable Changeable Message Sign (PCMS)
	Sign		Traffic Flow
	Flag		Flagger

Posted Speed	Formula	Minimum Desirable Taper Lengths "L"			Suggested Maximum Spacing of Channelizing Devices		Suggested Longitudinal Buffer Space "B"
		10' Offset	11' Offset	12' Offset	On a Taper	On a Tangent	
45	L = WS	450'	495'	540'	45'	90'	195'
50		500'	550'	600'	50'	100'	240'
55		550'	605'	660'	55'	110'	295'
60		600'	660'	720'	60'	120'	350'
65		650'	715'	780'	65'	130'	410'
70		700'	770'	840'	70'	140'	475'
75		750'	825'	900'	75'	150'	540'
80		800'	880'	960'	80'	160'	615'

** Taper lengths have been rounded off.
 L=Length of Taper (FT) W=Width of Offset(FT) S=Posted Speed(MPH)

TYPICAL USAGE				
MOBILE	SHORT DURATION	SHORT TERM STATIONARY	INTERMEDIATE TERM STATIONARY	LONG TERM STATIONARY
	✓	✓	✓	

- GENERAL NOTES**
- All traffic control devices illustrated are REQUIRED. Devices denoted with the triangle symbol may be omitted when stated elsewhere in the plans.
 - ADDED LANE Symbol (CW4-3) sign may be omitted when sign between ramp and mainlane can be seen from both roadways.
 - See "Advance Notice List" on BC(6) for recommended date and time formatting options for PCMS Phase 2 message.
 - The END ROAD WORK (G20-2) sign may be omitted when it conflicts with G20-2 signs already in place on the project.

*A shadow vehicle equipped with a Truck Mounted Attenuator is typically required. A shadow vehicle equipped with a TMA shall be used if it can be positioned 30' to 100' in advance of the area of crew exposure without adversely affecting the work performance.

Additional requirements for lane closures and advance signing shall be as shown on TCP (6-1) or as directed by the Engineer.

Texas Department of Transportation
 Traffic Operations Division Standard

TRAFFIC CONTROL PLAN
WORK AREA NEAR RAMP

TCP (6-2) - 12

FILE: tcp6-2.dgn	DN: TxDOT	CK: TxDOT	DW: TxDOT	CK: TxDOT
©TxDOT February 1994	CONT	SECT	JOB	HIGHWAY
REVISIONS	0095	14	033, ETC	IH 20, ETC
1-97 8-98	DIST	COUNTY	SHEET NO.	
4-98 8-12	DAL	KAUFMAN, ETC	94	

DISCLAIMER: The use of this standard is governed by the "Texas Engineering Practice Act". No warranty of any kind is made by TxDOT for any purpose whatsoever. TxDOT assumes no responsibility for the conversion of this standard to other formats or for incorrect results or damages resulting from its use.

DATE: 3/1/2023 4:31:55 PM
 FILE: T:\DAL\TRAFFIC\2023 PS&E\I.H. 20\Plan Set\Standards\non-paf_standards\095_tcp6-3.dwg

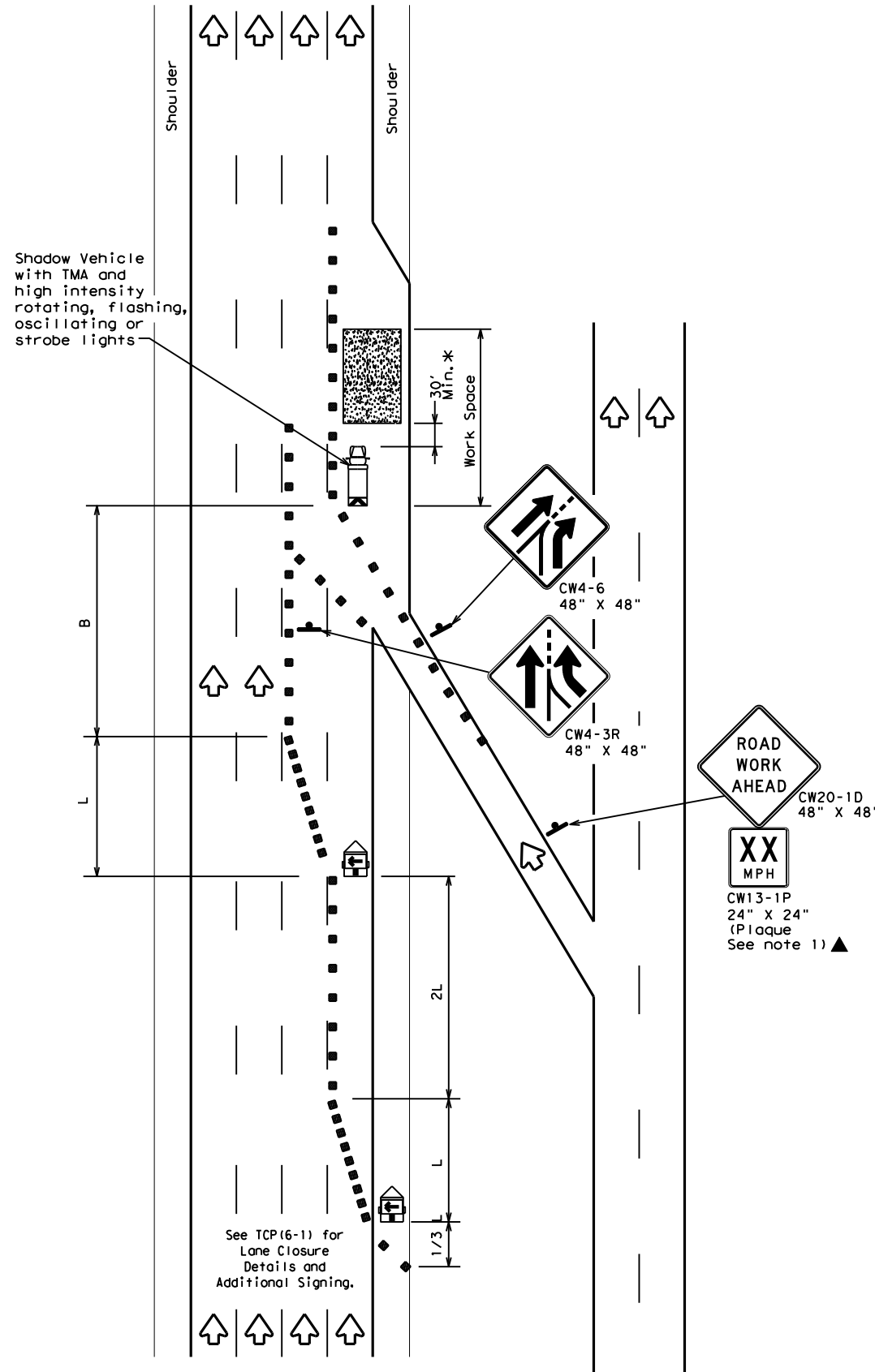

TCP (6-3a)
ENTRANCE RAMP OPEN

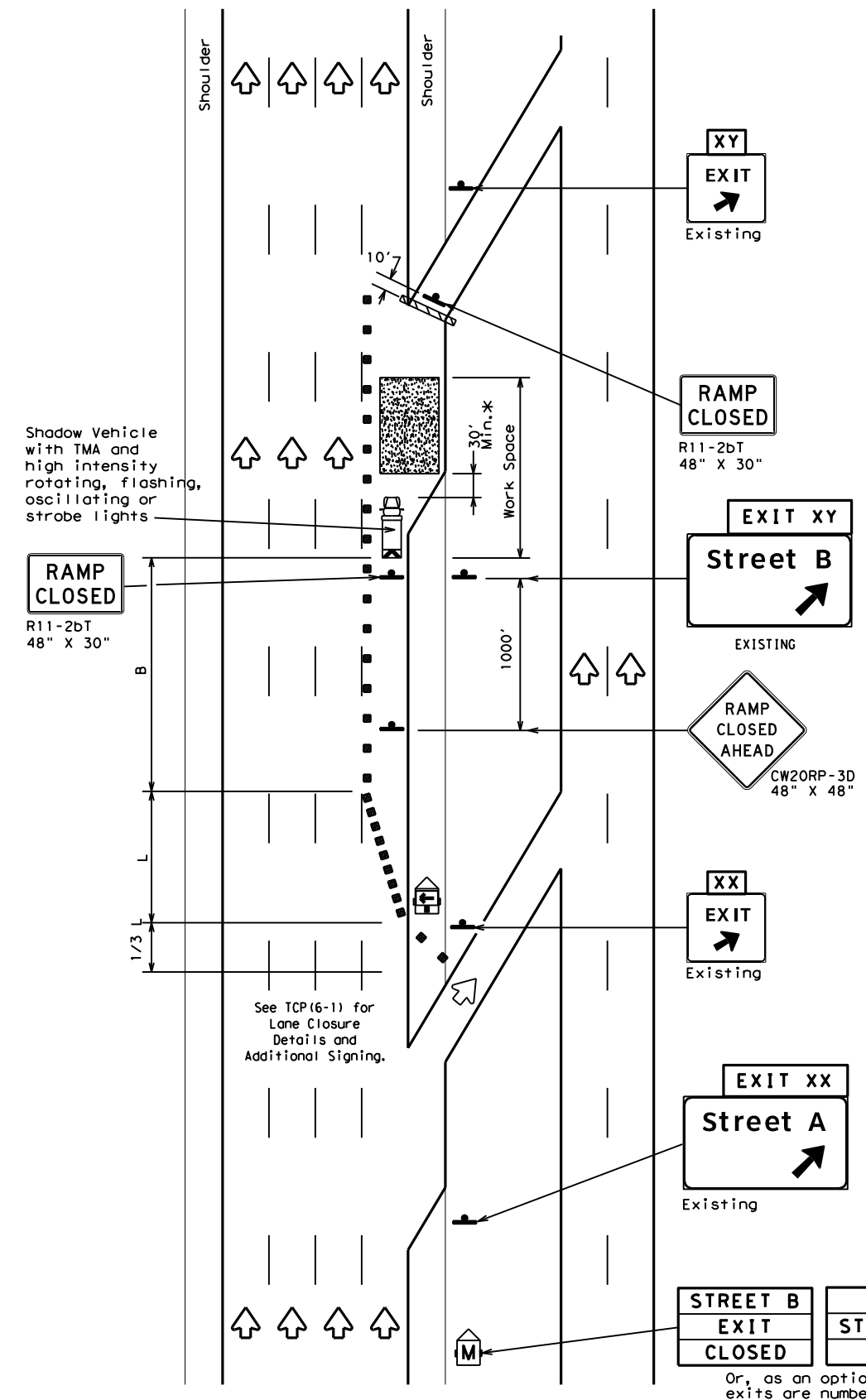

TCP (6-3b)
EXIT RAMP CLOSED
TRAFFIC EXITS PRIOR TO CLOSED RAMP

LEGEND			
	Type 3 Barricade		Channelizing Devices
	Heavy Work Vehicle		Truck Mounted Attenuator (TMA)
	Trailer Mounted Flashing Arrow Board		Portable Changeable Message Sign (PCMS)
	Sign		Traffic Flow
	Flag		Flagger

Posted Speed	Formula	Minimum Desirable Taper Lengths "L" **			Suggested Maximum Spacing of Channelizing Devices		Suggested Longitudinal Buffer Space "B"
		10' Offset	11' Offset	12' Offset	On a Taper	On a Tangent	
45	L = WS	450'	495'	540'	45'	90'	195'
50		500'	550'	600'	50'	100'	240'
55		550'	605'	660'	55'	110'	295'
60		600'	660'	720'	60'	120'	350'
65		650'	715'	780'	65'	130'	410'
70		700'	770'	840'	70'	140'	475'
75		750'	825'	900'	75'	150'	540'
80		800'	880'	960'	80'	160'	615'

** Taper lengths have been rounded off.
 L=Length of Taper (FT) W=Width of Offset (FT) S=Posted Speed (MPH)

TYPICAL USAGE				
MOBILE	SHORT DURATION	SHORT TERM STATIONARY	INTERMEDIATE TERM STATIONARY	LONG TERM STATIONARY
	✓	✓	✓	

GENERAL NOTES:

- All traffic control devices illustrated are REQUIRED. Devices denoted with the triangle symbol may be omitted when stated elsewhere in the plans.

*A shadow vehicle equipped with a Truck Mounted Attenuator is typically required. A shadow vehicle equipped with a TMA shall be used if it can be positioned 30' to 100' in advance of the area of crew exposure without adversely affecting the work performance.

Additional requirements for lane closures and advance signing shall be as shown on TCP (6-1) or as directed by the Engineer.

Texas Department of Transportation
 Traffic Operations Division Standard

TRAFFIC CONTROL PLAN
WORK AREA BEYOND RAMP

TCP (6-3) - 12

FILE: tcp6-3.dgn	DN: TxDOT	CK: TxDOT	DW: TxDOT	CR: TxDOT
©TxDOT February 1994	CONT	SECT	JOB	HIGHWAY
REVISIONS	0095 14		033, ETC	IH 20, ETC
1-97 8-98	DIST	COUNTY	SHEET NO.	
4-98 8-12	DAL	KAUFMAN, ETC	95	

DISCLAIMER: The use of this standard is governed by the "Texas Engineering Practice Act". No warranty of any kind is made by TxDOT for any purpose whatsoever. TxDOT assumes no responsibility for the conversion of any information into any other format or for incorrect results or damages resulting from its use.

DATE: 3/1/2023 4:31:56 PM
 FILE: T:\DAL\TRAFFIC\2023 PS&E\I\H 20\Plan Set\Standards\non-paf_standards\056\Traffic Control Plans\TCP (6-4) - 12.dwg

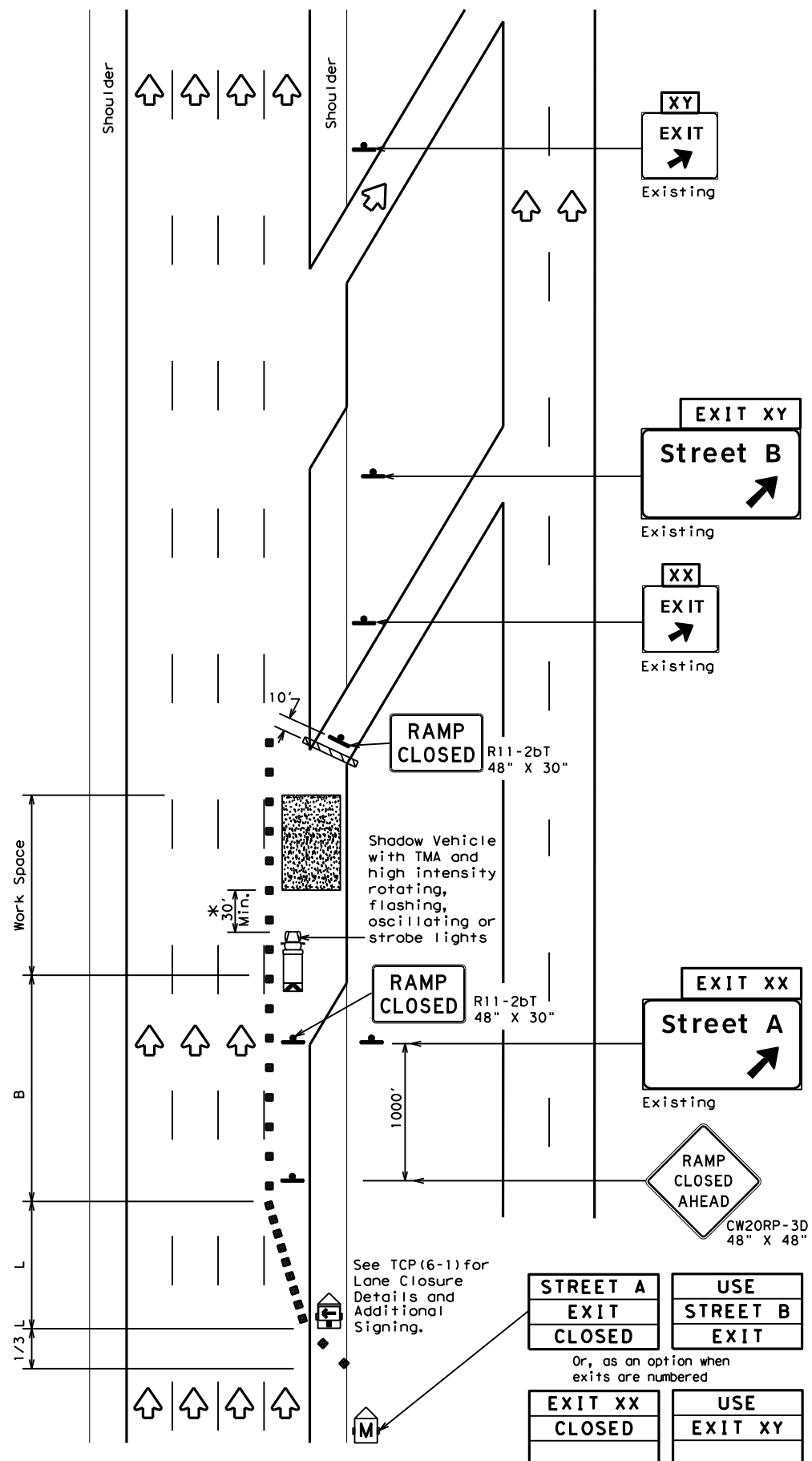

TCP (6-4a)
EXIT RAMP CLOSED
TRAFFIC EXITS PAST CLOSED RAMP

STREET A EXIT CLOSED	USE STREET B EXIT
EXIT XX CLOSED	USE EXIT XY

Or, as an option when exits are numbered

Place 1 mile (approx.) in advance of closed ramp.

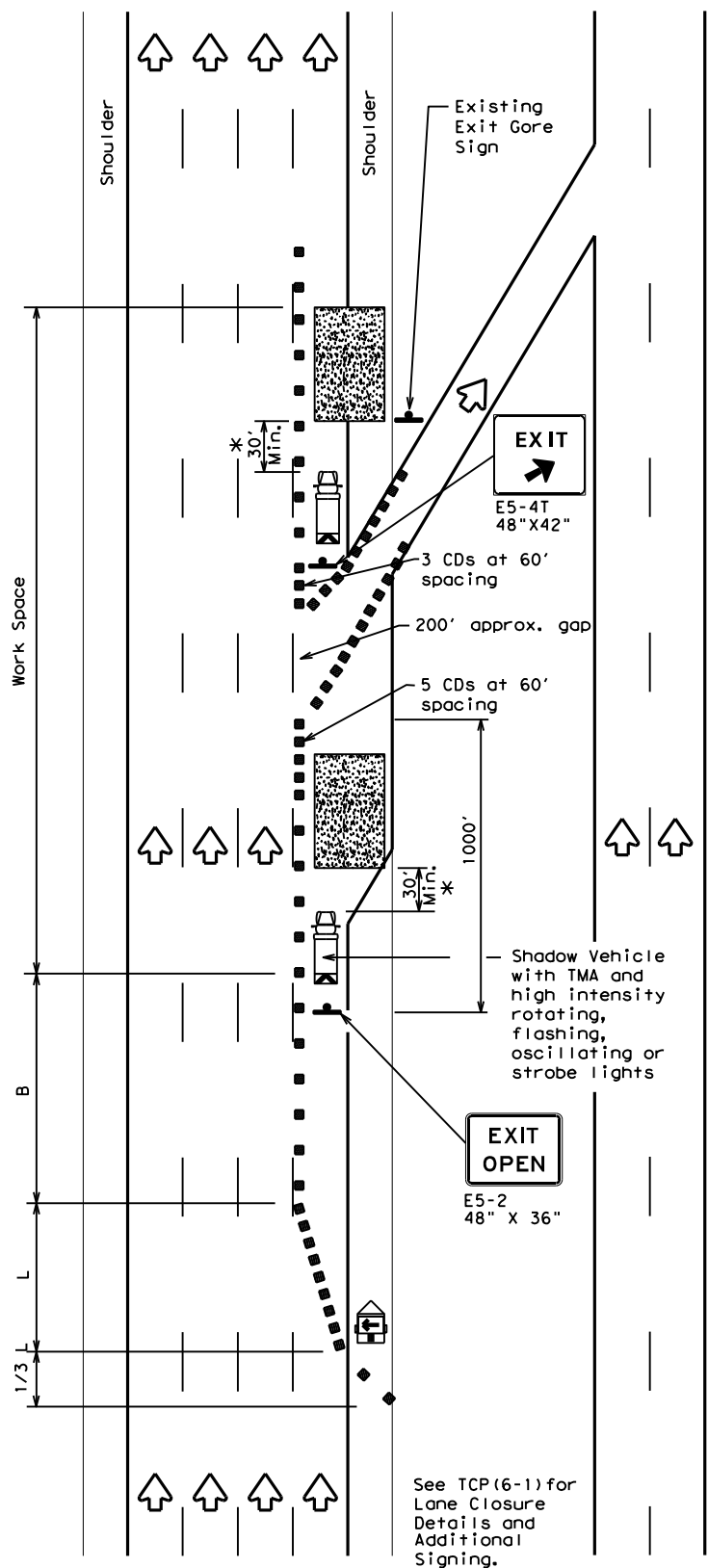

TCP (6-4b)
EXIT RAMP OPEN

LEGEND			
	Type 3 Barricade		Channelizing Devices (CDs)
	Heavy Work Vehicle		Truck Mounted Attenuator (TMA)
	Trailer Mounted Flashing Arrow Board		Portable Changeable Message Sign (PCMS)
	Sign		Traffic Flow
	Flag		Flagger

Posted Speed	Formula	Minimum Desirable Taper Lengths "L"			Suggested Maximum Spacing of Channelizing Devices		Suggested Longitudinal Buffer Space "B"
		10' Offset	11' Offset	12' Offset	On a Taper	On a Tangent	
45	L = WS	450'	495'	540'	45'	90'	195'
50		500'	550'	600'	50'	100'	240'
55		550'	605'	660'	55'	110'	295'
60		600'	660'	720'	60'	120'	350'
65		650'	715'	780'	65'	130'	410'
70		700'	770'	840'	70'	140'	475'
75		750'	825'	900'	75'	150'	540'
80		800'	880'	960'	80'	160'	615'

**Taper lengths have been rounded off.
 L=Length of Taper (FT) W=Width of Offset (FT) S=Posted Speed (MPH)

TYPICAL USAGE				
MOBILE	SHORT DURATION	SHORT TERM STATIONARY	INTERMEDIATE TERM STATIONARY	LONG TERM STATIONARY
	✓	✓	✓	

GENERAL NOTES

- All traffic control devices illustrated are REQUIRED. Devices denoted with the triangle symbol may be omitted when stated elsewhere in the plans.
- See BC Standards for sign details.

*A shadow vehicle equipped with a Truck Mounted Attenuator is typically required. A shadow vehicle equipped with a TMA shall be used if it can be positioned 30' to 100' in advance of the area of crew exposure without adversely affecting the work performance.

Additional requirements for lane closures and advance signing shall be as shown on TCP (6-1) or as directed by the Engineer.



TRAFFIC CONTROL PLAN
WORK AREA AT EXIT RAMP

TCP (6-4) - 12

FILE: tcp6-4.dgn	DN: TxDOT	CK: TxDOT	DW: TxDOT	CR: TxDOT
©TxDOT February 1994	CONT	SECT	JOB	HIGHWAY
REVISIONS	0095 14		033, ETC	IH 20, ETC
1-97 8-98	DIST	COUNTY	SHEET NO.	
4-98 8-12	DAL	KAUFMAN, ETC	96	

DATE: 3/1/2023 4:31:56 PM
 FILE: T:\DAL\TRAFM\FY_2023_PS&E\I\H_20\Plan_Set\Standards\non-paf_standards.dwg
 DISCLAIMER: The use of this standard is governed by the "Texas Engineering Practice Act". No warranty of any kind is made by TxDOT for any purpose whatsoever. TxDOT assumes no responsibility for the conversion of this standard to other formats or for incorrect results or damages resulting from its use.

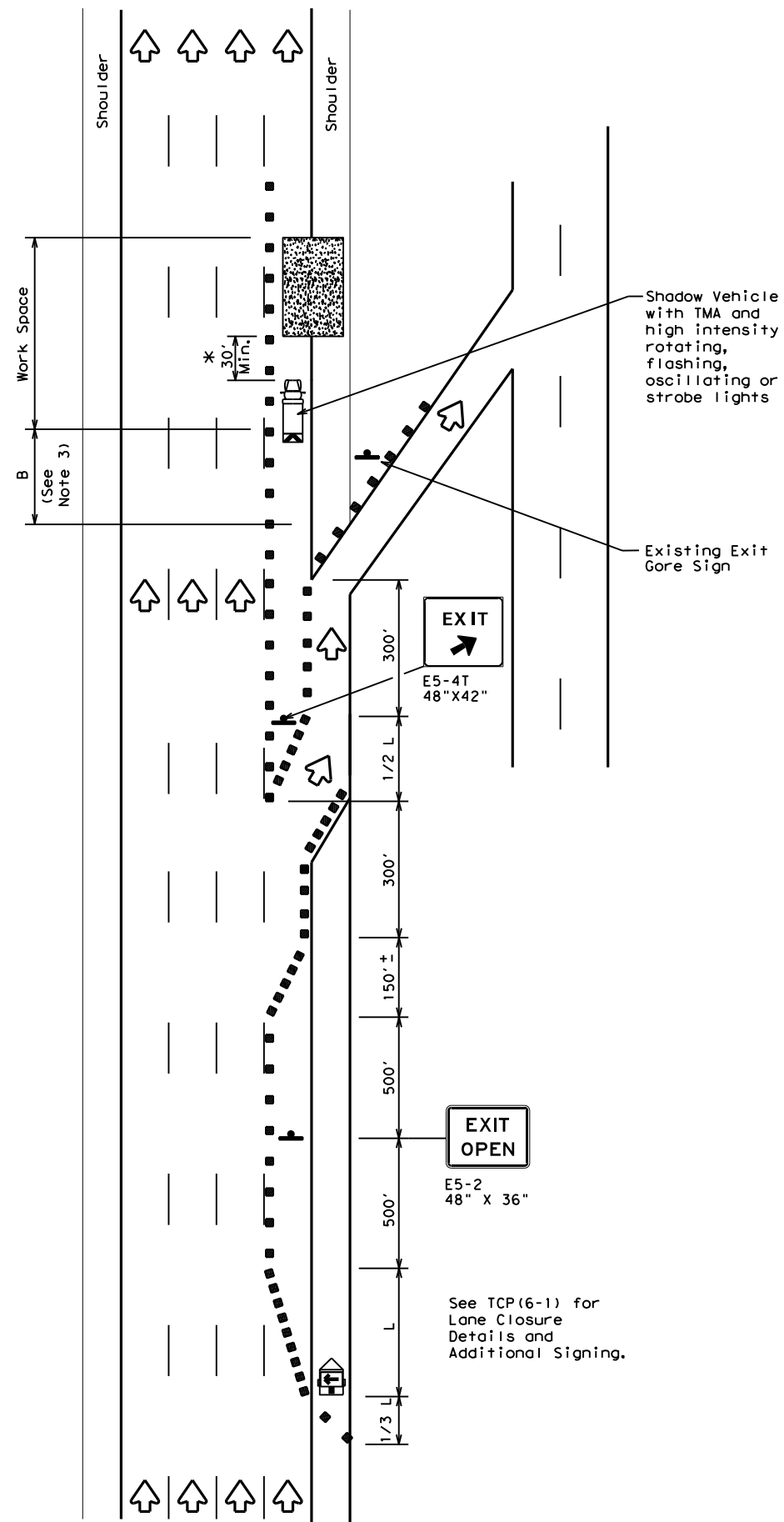

TCP (6-5a)
EXIT RAMP OPEN

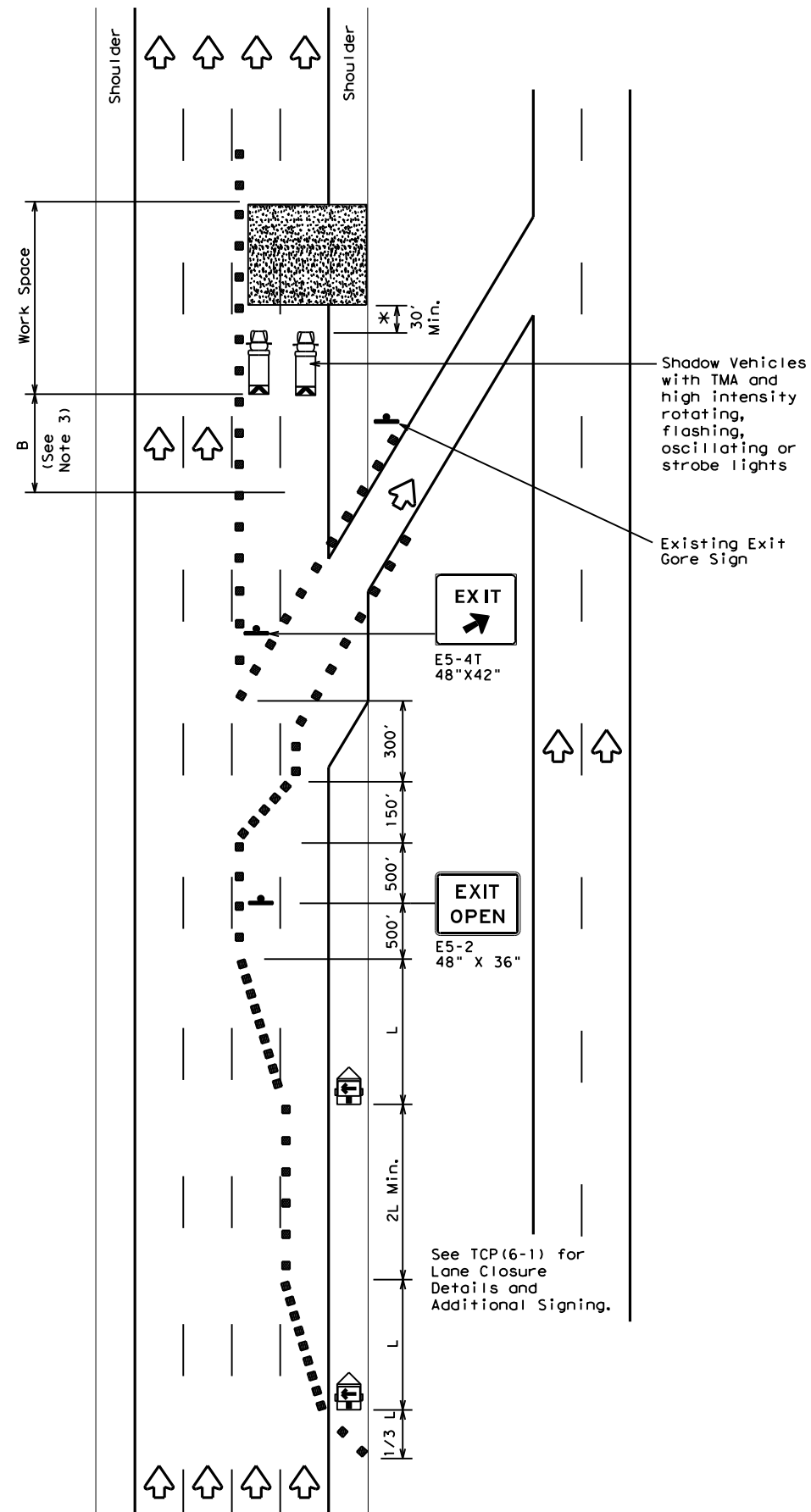

TCP (6-5b)
EXIT RAMP OPEN
TWO LANE CLOSURE WITHIN
1500' PAST EXIT RAMP

LEGEND			
	Type 3 Barricade		Channelizing Devices
	Heavy Work Vehicle		Truck Mounted Attenuator (TMA)
	Trailer Mounted Flashing Arrow Board		Portable Changeable Message Sign (PCMS)
	Sign		Traffic Flow
	Flag		Flagger

Posted Speed	Formula	Minimum Desirable Taper Lengths "L"			Suggested Maximum Spacing of Channelizing Devices		Suggested Longitudinal Buffer Space "B"
		10' Offset	11' Offset	12' Offset	On a Taper	On a Tangent	
45	L = WS	450'	495'	540'	45'	90'	195'
50		500'	550'	600'	50'	100'	240'
55		550'	605'	660'	55'	110'	295'
60		600'	660'	720'	60'	120'	350'
65		650'	715'	780'	65'	130'	410'
70		700'	770'	840'	70'	140'	475'
75		750'	825'	900'	75'	150'	540'
80		800'	880'	960'	80'	160'	615'

** Taper lengths have been rounded off.
 L=Length of Taper (FT) W=Width of Offset (FT) S=Posted Speed (MPH)

TYPICAL USAGE				
MOBILE	SHORT DURATION	SHORT TERM STATIONARY	INTERMEDIATE TERM STATIONARY	LONG TERM STATIONARY
	✓	✓	✓	

GENERAL NOTES

- All traffic control devices illustrated are REQUIRED. Devices denoted with the triangle symbol may be omitted when stated elsewhere in the plans.
- See BC standards for sign details.
- If adequate longitudinal buffer length "B" does not exist between the work space and the exit ramp, consideration should be given to closing the ramp.

*A shadow vehicle equipped with a Truck Mounted Attenuator is typically required. A shadow vehicle equipped with a TMA shall be used if it can be positioned 30' to 100' in advance of the area of crew exposure without adversely affecting the work performance.

Additional requirements for lane closures and advance signing shall be as shown on TCP (6-1) or as directed by the Engineer.



TRAFFIC CONTROL PLAN
WORK AREA BEYOND EXIT RAMP

TCP (6-5) - 12

FILE: tcp6-5.dgn	DN: TxDOT	CK: TxDOT	DW: TxDOT	CK: TxDOT
©TxDOT February 1998	CONT	SECT	JOB	HIGHWAY
REVISIONS	0095 14		033, ETC	IH 20, ETC
1-97 8-98	DIST	COUNTY		SHEET NO.
4-98 8-12	DAL	KAUFMAN, ETC		97

DISCLAIMER: The use of this standard is governed by the "Texas Engineering Practice Act". No warranty of any kind is made by TxDOT for any purpose whatsoever. TxDOT assumes no responsibility for the conversion of this standard to other formats or for incorrect results or damages resulting from its use.

DATE: 3/1/2023 4:31:57 PM
 FILE: T:\DAL\TRAFFIC\2023 PS&E\I\H 20\Plan Set\Standards\non-paf_standards\098_tcp6-8.dgn

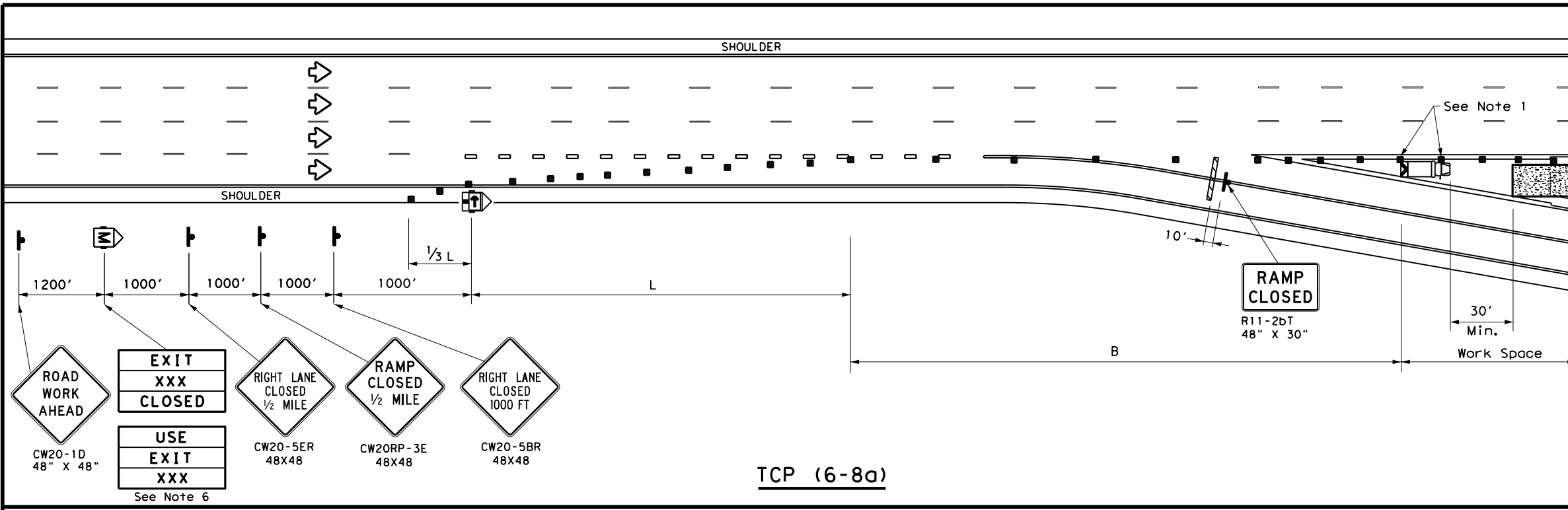

TCP (6-8a)

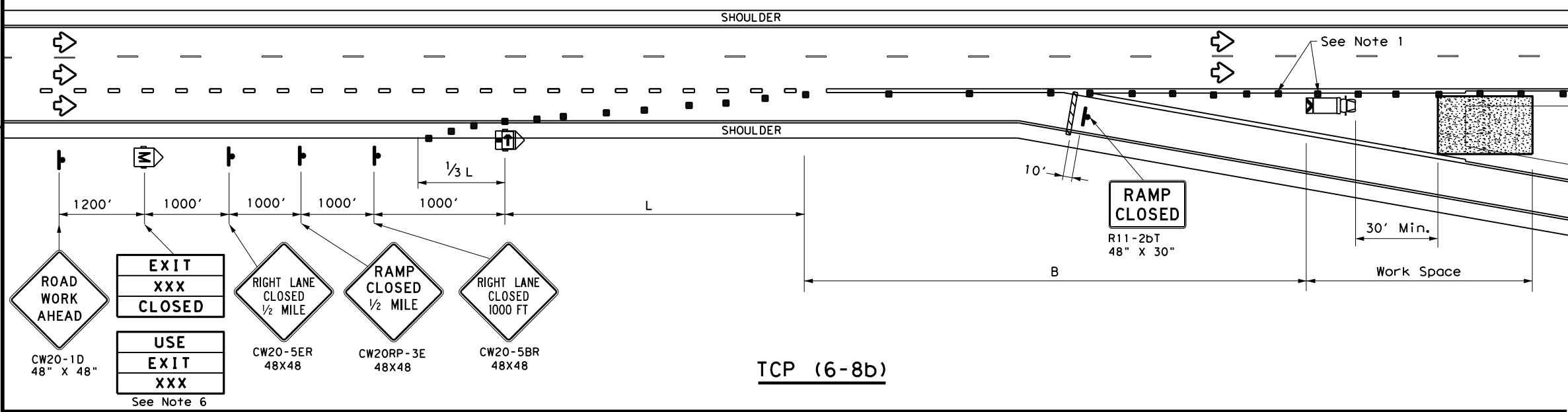

TCP (6-8b)

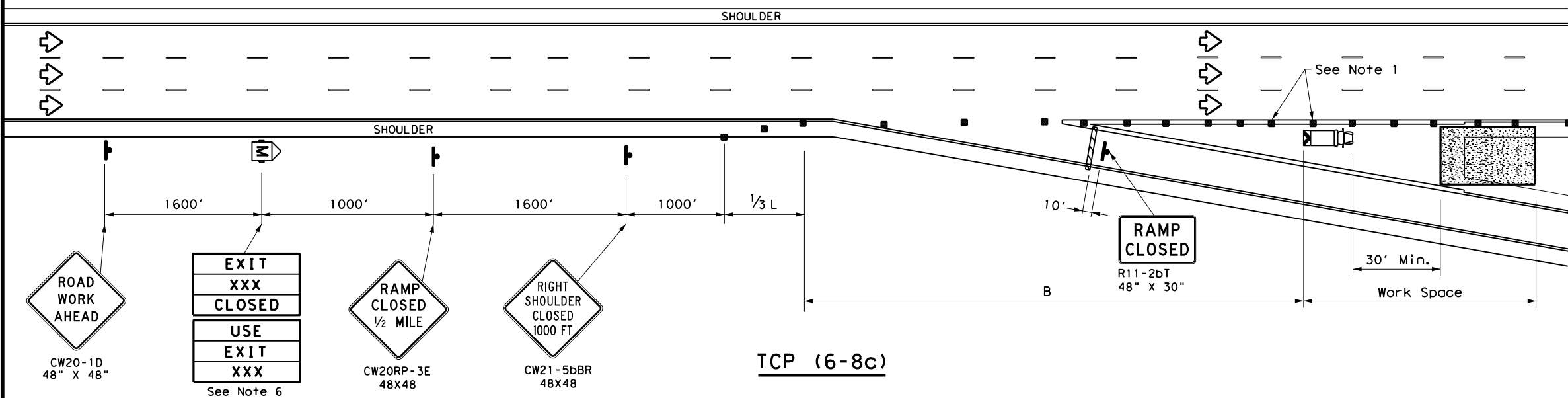

TCP (6-8c)

LEGEND			
	Type 3 Barricade		Channelizing Devices (CDs)
	Heavy Work Vehicle		Truck Mounted Attenuator (TMA)
	Trailer Mounted Flashing Arrow Board		Portable Changeable Message Sign (PCMS)
	Sign		Traffic Flow
	Flag		Flagger

Posted Speed	Formula	Minimum Desirable Taper Lengths "L" **			Suggested Maximum Spacing of Channelizing Devices		Suggested Longitudinal Buffer Space "B"
		10' Offset	11' Offset	12' Offset	On a Taper	On a Tangent	
45	L = WS	450'	495'	540'	45'	90'	195'
50		500'	550'	600'	50'	100'	240'
55		550'	605'	660'	55'	110'	295'
60		600'	660'	720'	60'	120'	350'
65		650'	715'	780'	65'	130'	410'
70		700'	770'	840'	70'	140'	475'
75		750'	825'	900'	75'	150'	540'
80		800'	880'	960'	80'	160'	615'

** Taper lengths have been rounded off.
 L=Length of Taper (FT) W=Width of Offset (FT)
 S=Posted Speed (MPH)

TYPICAL USAGE				
MOBILE	SHORT DURATION	SHORT TERM STATIONARY	INTERMEDIATE TERM STATIONARY	LONG TERM STATIONARY
	✓	✓		

- GENERAL NOTES**
- Place channelizing devices in the gore at 20' spacing.
 - See the Standard Highway Sign Design for Texas (SHSD) for sign details.
 - The PCMS may be omitted when a permanent DMS sign is available in an appropriate location to display a similar message as called for on the PCMS.
 - When it is determined that a through lane should be closed in addition to the exit ramp, refer to TCP(6-4) for traffic control details.
 - Truck mounted attenuator is required.
 - The PCMS may be omitted if replaced with a "RAMP CLOSED" AHEAD (CW20RP-3D) Sign.
 - Roadway ADT should be greater than 10,000.



WORK IN EXIT GORE FOR ADT GREATER THAN 10,000

TCP (6-8) - 14

FILE: tcp6-8.dgn	DN: TxDOT	CK: TxDOT	DW: TxDOT	CK: TxDOT
© TxDOT February 2014	CONT	SECT	JOB	HIGHWAY
REVISIONS	0095 14	033, ETC	IH 20, ETC	
DIST	COUNTY	SHEET NO.		
DAL	KAUFMAN, ETC	98		

DATE: 3/11/2023
 FILE: T:\DAL\TRAFFIC\2023 PS&E\14 20\Xpion Set\Standards\Non-pdf_standards\099_GF (31)-19.dgn
 DISCLAIMER: THE USE OF THIS STANDARD IS GOVERNED BY THE "TEXAS ENGINEERING PRACTICE ACT". NO WARRANTY OF ANY KIND IS MADE BY TXDOT FOR ANY PURPOSE WHATSOEVER. TXDOT ASSUMES NO RESPONSIBILITY FOR THE CONVERSION OF THIS STANDARD TO OTHER FORMATS OR FOR INCORRECT RESULTS OR DAMAGES RESULTING FROM ITS USE.

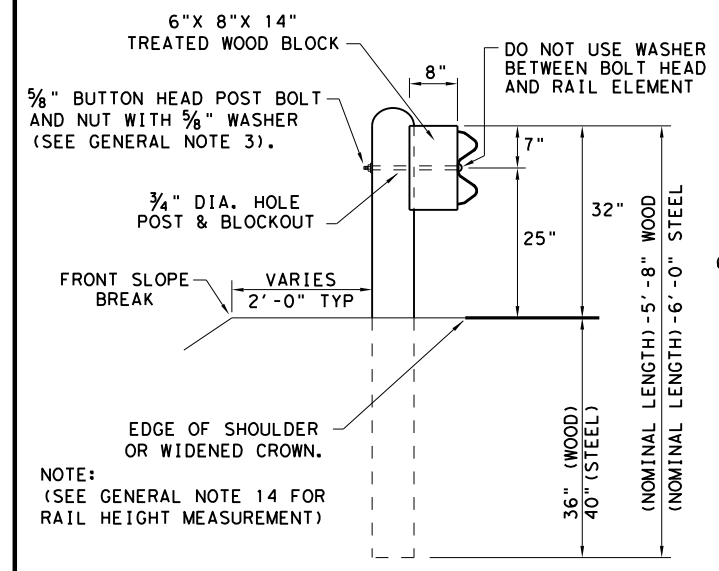

TYPICAL POST PLACEMENT

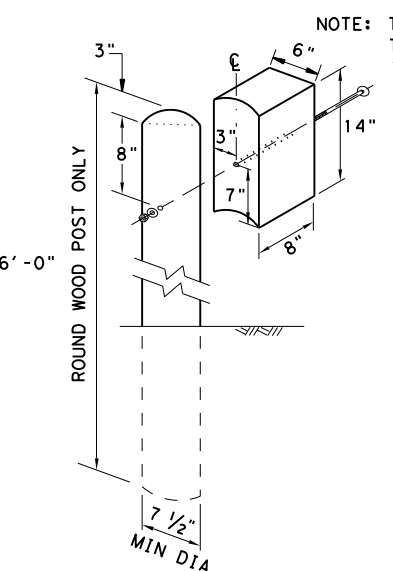

WOOD BLOCK TO ROUND WOOD POST

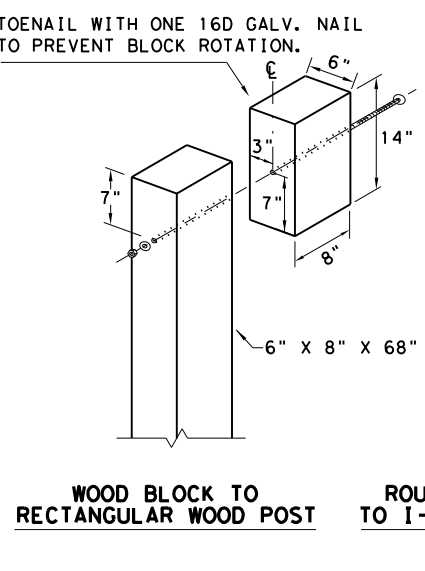

WOOD BLOCK TO RECTANGULAR WOOD POST

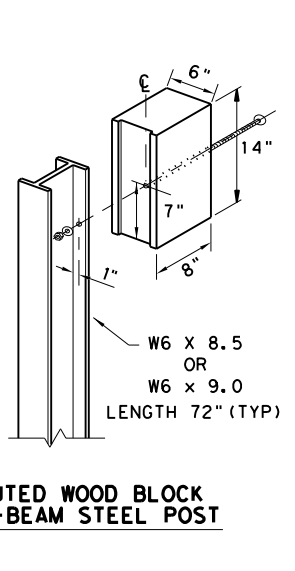

ROUTED WOOD BLOCK TO I-BEAM STEEL POST

GENERAL NOTES

1. THE TYPE OF POST (ROUND WOOD POST, RECTANGULAR WOOD POST, OR STEEL POST) WILL BE AS SHOWN IN THE PLANS. THE EXACT POSITION OF MBGF SHALL BE SHOWN IN THE PLANS OR AS DIRECTED BY THE ENGINEER. STEEL POSTS TO BE GALVANIZED IN ACCORDANCE WITH ITEM 445, "GALVANIZING."
2. RAIL ELEMENTS SHALL MEET THE REQUIREMENTS OF ITEM 540, "METAL BEAM GUARD FENCE" EXCEPT AS MODIFIED IN THE PLANS. THE CONTRACTOR MAY FURNISH RAIL ELEMENTS OF 25'-0", OR 12'-6" (NOM.) LENGTHS. RAIL ELEMENTS MAY HAVE SLOTTED HOLES AT 3'-1 1/2" C-C OR 6'-3" C-C. A SPECIAL LENGTH OF RAIL MAY BE MANUFACTURED TO ACCOMMODATE THE DOWNSTREAM ANCHOR TERMINAL (DAT) AND THE TRANSITION SECTIONS OF GUARDRAIL.
3. BUTTON HEAD "POST BOLTS & NUTS" SHALL MEET THE REQUIREMENTS OF (ASTM A307), AND SHALL BE OF SUFFICIENT LENGTH TO EXTEND THROUGH THE FULL THICKNESS OF THE NUT AND 3/8" WASHER (FWC160) AND NOT MORE THAN 1" BEYOND IT. TRIM REMAINING BOLT LENGTH TO MEET REQUIRED LENGTH.
4. FITTINGS (BOLTS, NUTS, AND WASHERS) SHALL BE GALVANIZED IN ACCORDANCE WITH ITEM 445, "GALVANIZING." FITTINGS SHALL BE SUBSIDIARY TO THE BID ITEM.
5. CROWN SHALL BE WIDENED TO ACCOMMODATE THE METAL BEAM GUARD FENCE.
6. THE LATERAL APPROACH TO THE GUARD FENCE, SHALL HAVE A MAXIMUM SLOPE OF 1V:10H.
7. IF SHOWN ELSEWHERE IN THE PLANS OR AS DIRECTED BY THE ENGINEER, THE GUARD FENCE MAY BE FLARED AT A RATE OF 25:1 OR FLATTER.
8. UNLESS OTHERWISE SHOWN IN THE PLANS, GUARD FENCE PLACED IN THE VICINITY OF CURBS SHALL BE POSITIONED SO THAT THE FACE OF CURB IS LOCATED DIRECTLY BELOW OR BEHIND THE FACE OF THE RAIL. RAIL PLACED OVER CURBS SHALL BE INSTALLED SO THAT THE POST BOLT IS LOCATED APPROXIMATELY 25 INCHES ABOVE THE GUTTER PAN OR EDGE OF SHOULDER.
9. APPLICATIONS IN SOLID ROCK ARE ONLY ALLOWED WITH STEEL POSTS. IF SOLID ROCK IS ENCOUNTERED WITHIN 0 TO 18" OF THE FINISHED GRADE, DRILL A 24" DIA. HOLE, 24" INTO THE ROCK. IF SOLID ROCK IS ENCOUNTERED BELOW 18", DRILL A 12" DIA. HOLE, 12" INTO THE ROCK OR TO THE STANDARD EMBEDMENT DEPTH, WHICHEVER MAYBE LESS. ANY EXCESS POST LENGTH, AFTER MEETING THESE DEPTHS, MAY BE FIELD CUT TO ENSURE PROPER GUARDRAIL MOUNTING HEIGHT. BACKFILL WITH COARSE AGGREGATE MATERIAL.
10. POSTS SHALL NOT BE SET IN CONCRETE, OF ANY DEPTH.
11. SPECIAL FABRICATION WILL BE REQUIRED AT INSTALLATION LOCATIONS HAVING A CURVATURE OF LESS THAN 150 FT. RADIUS.
12. UNLESS OTHERWISE SHOWN IN THE PLANS, A COMPOSITE MATERIAL BLOCK THAT MEETS THE REQUIREMENTS OF DMS-7210, "COMPOSITE MATERIAL POSTS AND BLOCKS FOR METAL BEAM GUARD FENCE" MAY BE SUBSTITUTED FOR BLOCKS OF SIMILAR DIMENSIONS. THE CONSTRUCTION DIVISION, TXDOT MAINTAINS A MATERIAL PRODUCER LIST (MPL) FOR PRODUCERS OF MATERIALS CONFORMING TO DMS-7210 ONLY PRODUCERS ON THE MPL MAY FURNISH COMPOSITE MATERIAL BLOCKS.
13. FOR THE LOW FILL CULVERT OPTION, POSTS LOCATED PARTIALLY OR WHOLLY BETWEEN PRECAST BOX CULVERT UNITS, THE USE OF A CAST-IN-PLACE CONCRETE CLOSURE BETWEEN BOXES IS REQUIRED. THE LENGTH OF THE CAST-IN-PLACE CONCRETE CLOSURE SHALL ACCOMMODATE THE PLACEMENT OF THE LOW FILL CULVERT OPTION. SEE CONCRETE CLOSURE DETAILS ON BRIDGE STANDARD SCP-MD.
14. GUARDRAIL HEIGHT MEASUREMENT: WHEN THE GUARDRAIL IS LOCATED ABOVE PAVEMENT, MEASURE THE HEIGHT FROM THE PAVEMENT TO THE TOP OF THE W-BEAM RAIL. WHEN THE GUARDRAIL IS LOCATED UP TO 2 FT. OFF OF THE EDGE OF PAVEMENT OR FOR A PAVEMENT OVERLAY, USE A 10-FOOT STRAIGHTEDGE TO EXTEND THE PAVEMENT/SHOULDER SLOPE TO THE BACK OF RAIL, MEASURE FROM THE BOTTOM OF STRAIGHTEDGE TO THE TOP OF RAIL. FOR GUARDRAIL LOCATED DOWN A 10:1 SLOPE, MEASURE FROM THE NOMINAL TERRAIN.

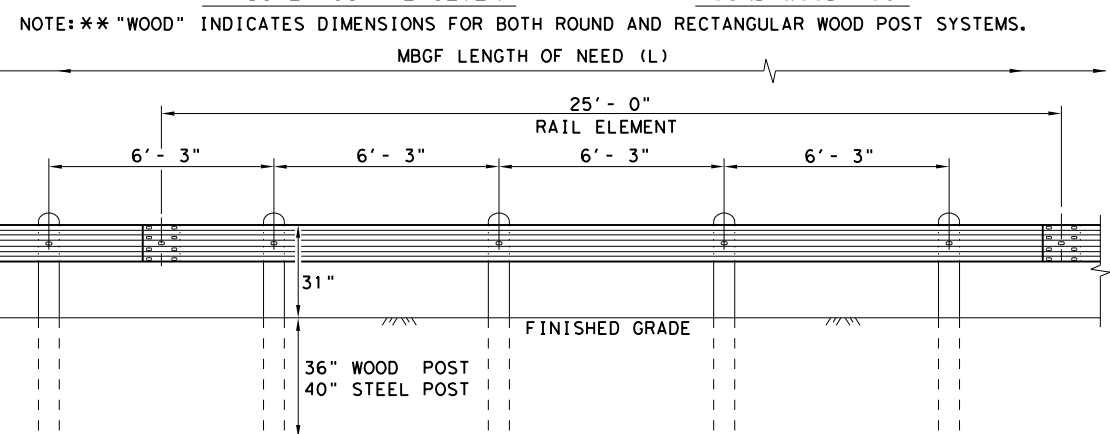

ELEVATION MID-SPAN RAIL SPLICE

NOTE: ** "WOOD" INDICATES DIMENSIONS FOR BOTH ROUND AND RECTANGULAR WOOD POST SYSTEMS.
 SHOWING A 25'-0" SECTION OF W-BEAM RAIL. (SEE GENERAL NOTE 2)

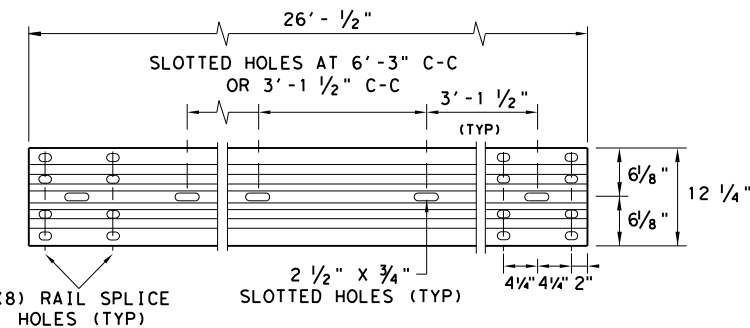

ELEVATION 25'-0" (NOM.) W-BEAM SECTION

NOTES: SEE GENERAL NOTE 2 FOR ALLOWABLE RAIL TYPES. SEE RAIL SPLICE DETAIL FOR REQUIRED HARDWARE.

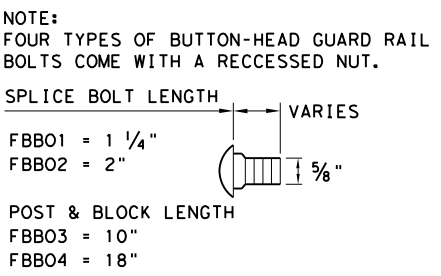

BUTTON HEAD BOLT

NOTE: SEE GENERAL NOTE 3 FOR SPLICE & POST BOLT DETAILS.

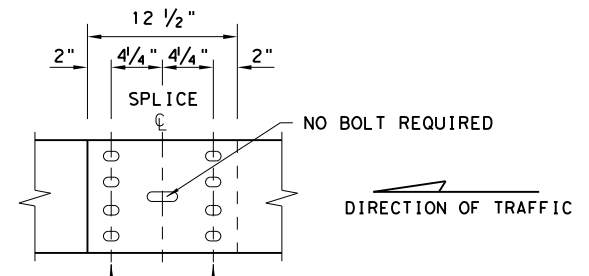

MID-SPAN RAIL SPLICE DETAIL

NOTE: GF(31), MID-SPAN RAIL SPLICES ARE REQUIRED WITH 6'-3" POST SPACINGS.

* POST(S) MAY REQUIRE FIELD MODIFICATION TO ENSURE PROPER GUARDRAIL HEIGHT.

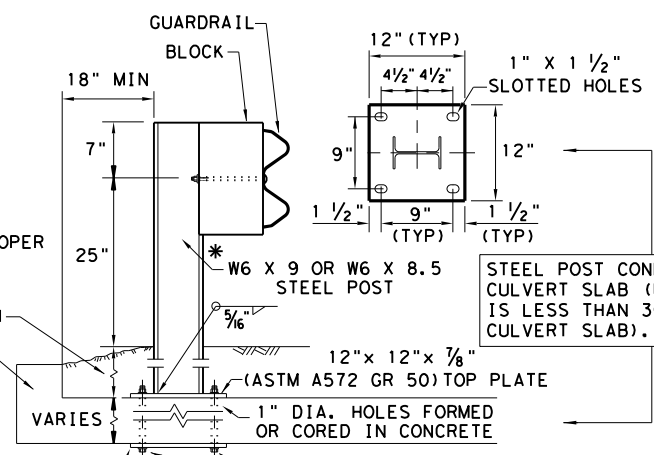

LOW FILL CULVERT POST

NOTE: TWO INSTALLATION OPTIONS.

1. **BOLT-THROUGH OPTION:** REQUIRES A 6" MIN. SLAB THICKNESS. 7/8" DIA (ASTM A449) HEAVY HEX BOLTS WITH TWO HARDENED WASHER EACH AND HEAVY HEX NUTS. NOTE: BOLT LENGTH = SLAB PLUS 2 1/4" MIN.
2. **EPOXY ANCHOR OPTION:** THIS OPTION MAY ONLY BE USED IF THE CULVERT SLAB IS 9" MIN. THICK. THREADED ANCHOR RODS MUST BE 7/8" DIA. ASTM A449 OR A193 GRADE B7 WITH HEAVY HEX NUT, AND ONE HARDENED WASHER EACH. EMBED ANCHOR RODS 6" WITH HILTI HIT RE 500 EPOXY ADHESIVE. OTHER TYPE III CLASS C EPOXY ADHESIVES MEETING THE REQUIREMENTS OF DMS-6100, "EPOXIES AND ADHESIVES", MAY BE USED IF IT CAN BE DEMONSTRATED THAT THEY MEET OR EXCEED THE STRENGTH OF HILTI HIT RE 500 WITH THE SAME EMBEDMENT DEPTH AND THREADED ROD DIA. FOLLOW THE MANUFACTURER'S REQUIREMENTS FOR INSTALLING EPOXIED THREADED RODS. EXTEND RODS 1/4" MIN. BEYOND NUT.

NOTE: CULVERTS OF 25 FT. OR LESS, SEE GF(31)LS STANDARD FOR "LONG SPAN" OPTION.

				Design Division Standard	
METAL BEAM GUARD FENCE TL-3 MASH COMPLIANT GF (31)-19					
FILE: gf3119.dgn	DN: TXDOT	CK: KM	DW: VP	CK: CGL/AG	
© TXDOT: NOVEMBER 2019	CONT	SECT	JOB	HIGHWAY	
REVISIONS	0095	14	033, ETC	IH 20, ETC	
	DIST	COUNTY		SHEET NO.	
DAL	KAUFMAN, ETC			99	

3/11/2023
 DATE: 3/11/2023
 FILE: T:\DALTRAFM\FY 2023 PS&E\I.H. 20\Plan Set\Standard\ds\non-pdf_standard\100_GF(31)DAT-19.dgn
 DISCLAIMER: THE USE OF THIS STANDARD IS GOVERNED BY THE "TEXAS ENGINEERING PRACTICE ACT". NO WARRANTY OF ANY KIND IS MADE BY TXDOT FOR ANY PURPOSE WHATSOEVER. TXDOT ASSUMES NO RESPONSIBILITY FOR THE CONVERSION OF THIS STANDARD TO OTHER FORMATS OR FOR INCORRECT RESULTS OR DAMAGES RESULTING FROM ITS USE.

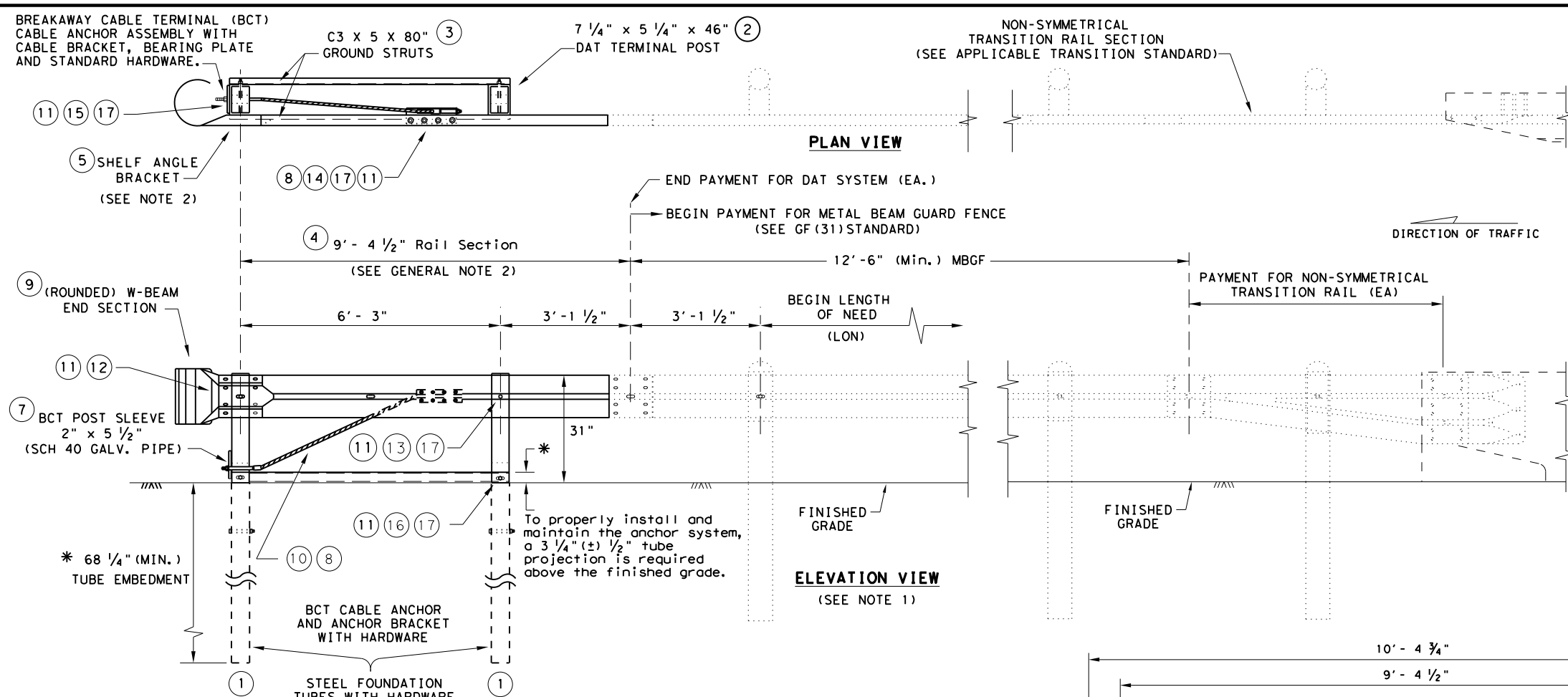

NON-SYMMETRICAL
TRANSITION RAIL SECTION
(SEE APPLICABLE TRANSITION STANDARD)

GENERAL NOTES

1. THE DETAIL SHOWN IS THE MINIMUM LENGTH OF NEED (LON) FOR A DOWNSTREAM ANCHOR TERMINAL (DAT) CONNECTED TO A CONCRETE RAIL.
2. THE RAIL SECTION AT THE END POST IS SUPPORTED BY THE SHELF ANGLE BRACKET. THE RAIL ELEMENT IS NOT ATTACHED TO THE END POST.
3. THE FOUNDATION TUBES SHALL NOT PROJECT MORE THAN 3 3/4" ABOVE THE FINISHED GRADE.
4. ALL HARDWARE FOR DAT SHALL BE ASTM A307 UNLESS OTHERWISE SHOWN.
5. REFER TO GF(31) SHEET FOR TERMINAL CONNECTION DETAILS.

MOW STRIP INSTALLATION
 IF A MOW STRIP IS REQUIRED WITH THE DAT INSTALLATION THE LEAVE-OUT AREA AROUND THE STEEL FOUNDATION TUBES AND THE TWO CHANNEL STRUTS MAY BE OMITTED. THIS WILL REQUIRE A FULL POUR AT THE FOUNDATION TUBES.

DOWNSTREAM ANCHOR TERMINAL (DAT)

NOTE: ONLY FOR DOWNSTREAM USE, WHEN LOCATED OUTSIDE THE HORIZONTAL CLEARANCE AREA OF OPPOSING TRAFFIC.

#	(DAT) PARTS LIST	QTY
1	STEEL FOUNDATION TUBE	2
2	DAT TERMINAL POST	2
3	CHANNEL STRUT	2
4	TERMINAL RAIL ELEMENT	1
5	SHELF ANGLE BRACKET	1
6	BCT BEARING PLATE	1
7	BCT POST SLEEVE	1
8	GUARDRAIL ANCHOR BRACKET	1
9	(ROUNDED) W-BEAM END SECTION	1
10	BCT CABLE ANCHOR	1
11	RECESSED NUT, GUARDRAIL	20
12	1 1/4" BUTTON HEAD BOLT	4
13	10" BUTTON HEAD BOLT	2
14	5/8" X 2" HEX HEAD BOLT	8
15	5/8" X 8" HEX HEAD BOLT	4
16	5/8" X 10" HEX HEAD BOLT	2
17	5/8" FLAT WASHER	18

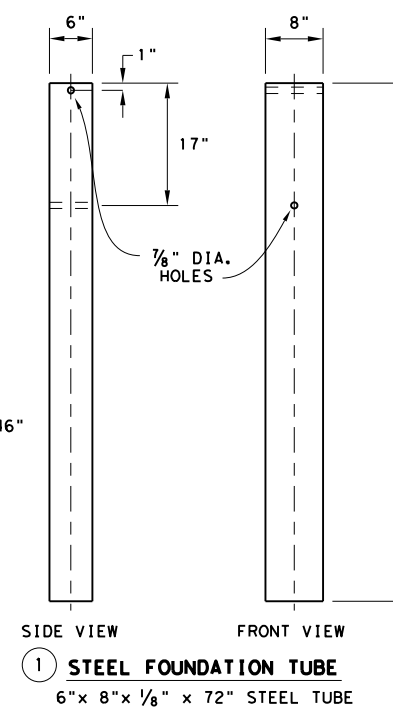
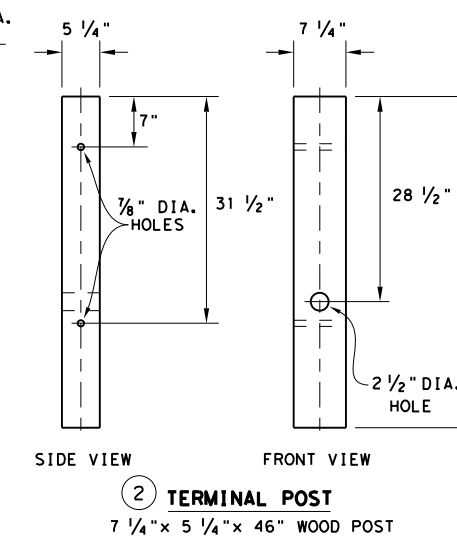
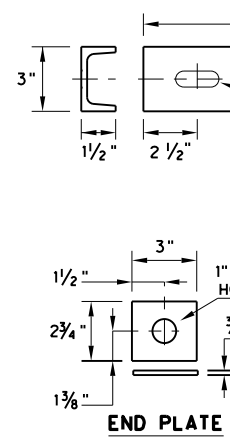
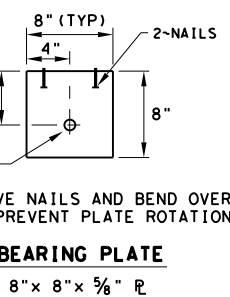
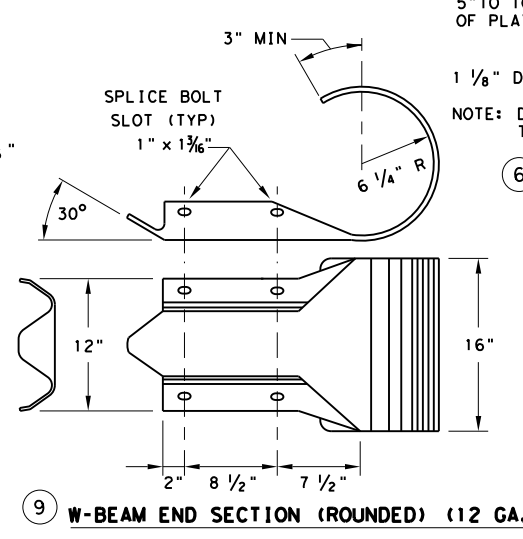
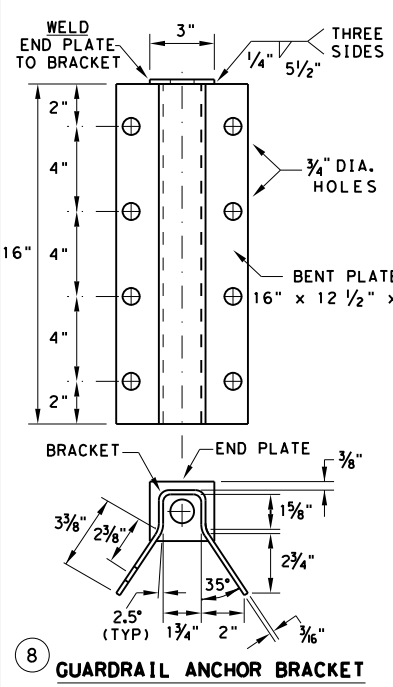
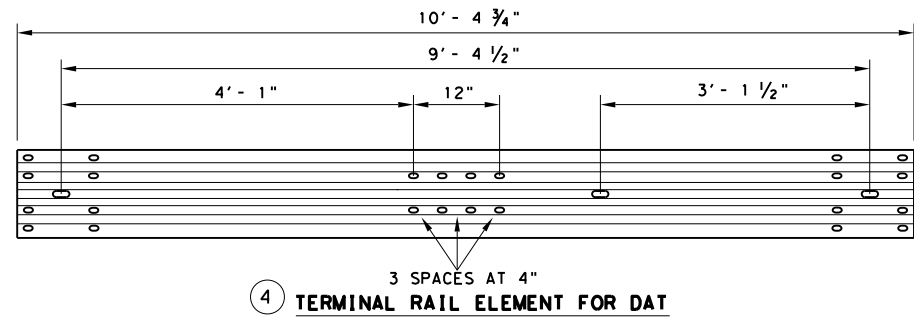

Design Division Standard
METAL BEAM GUARD FENCE (DOWNSTREAM ANCHOR TERMINAL) TL-3 MASH COMPLIANT GF(31)DAT-19
 FILE: gf31dat19.dgn DN: TXDOT CK: KM DW: VP CK: CGL/AG
 © TXDOT: NOVEMBER 2019 CONT SECT JOB HIGHWAY
 REVISIONS 0095 14 033, ETC IH 20, ETC
 DIST COUNTY SHEET NO.
 DAL KAUFMAN, ETC 100

DATE: 3/2/2023
 FILE: T:\DAL\TRAFFIC.FY 2023 PS&E\I.H. 20\Plan Set\Standard\Non-pdf standard\101_SGT(12S)31-18.dgn
 DISCLAIMER: THIS STANDARD IS GOVERNED BY THE "TEXAS ENGINEERING PRACTICE ACT". NO WARRANTY OF ANY KIND IS MADE BY TXDOT FOR ANY PURPOSE WHATSOEVER. TXDOT ASSUMES NO RESPONSIBILITY FOR THE CONVERSION OF THIS STANDARD TO OTHER FORMATS OR FOR INCORRECT RESULTS OR DAMAGES RESULTING FROM ITS USE.

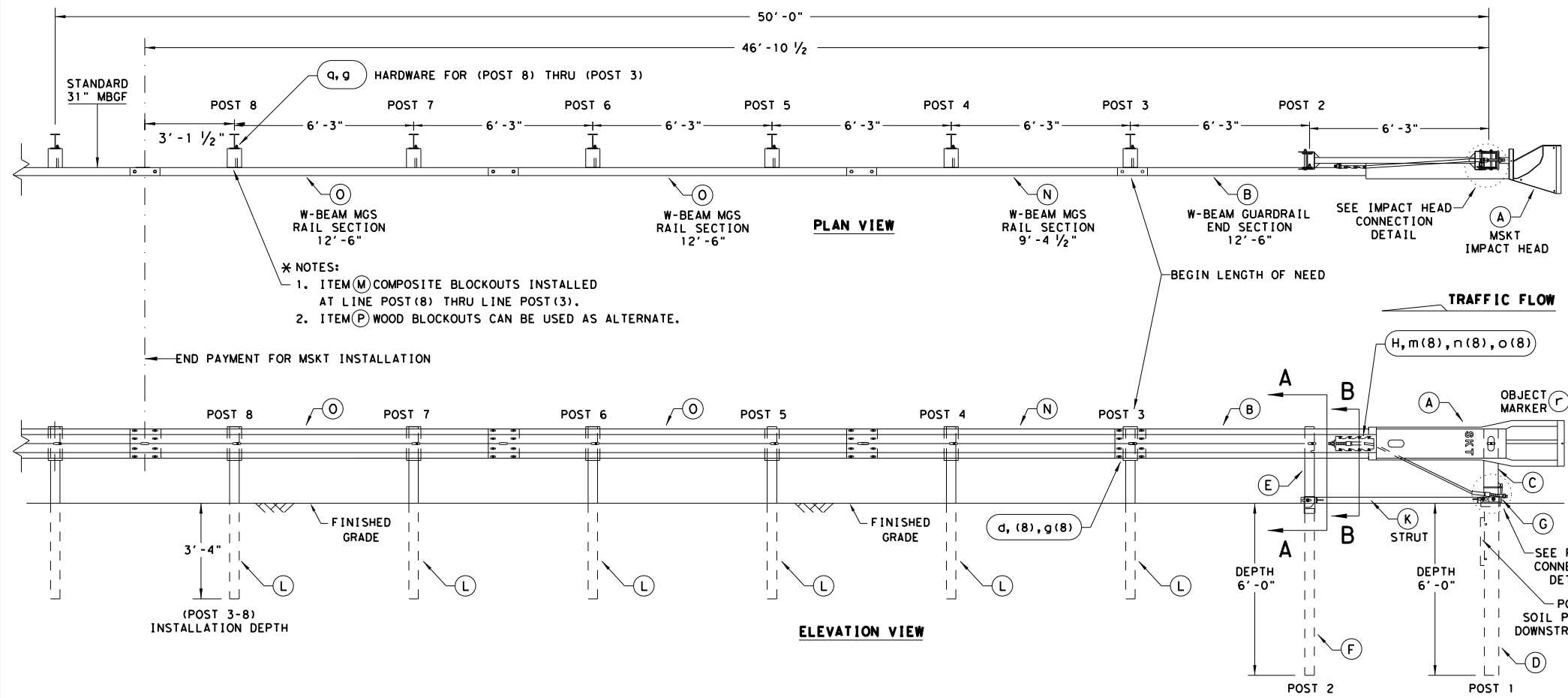

- * NOTES:**
- ITEM (M) COMPOSITE BLOCKOUTS INSTALLED AT LINE POST (8) THRU LINE POST (3).
 - ITEM (P) WOOD BLOCKOUTS CAN BE USED AS ALTERNATE.

- GENERAL NOTES**
- FOR SPECIFIC INFORMATION REGARDING INSTALLATION AND TECHNICAL GUIDANCE OF THE SYSTEM, CONTACT: ROAD SYSTEMS, INC. (432)263-2435. 3616 OLD HOWARD COUNTY AIRPORT, BIG SPRING, TX 79720
 - FOR INSTALLATION, REPAIR AND MAINTENANCE REFER TO THE: MSKT END TERMINAL, PRODUCT DESCRIPTION ASSEMBLY MANUAL (PUBLICATION-062717).
 - APPLY HIGH INTENSITY REFLECTIVE SHEETING, "OBJECT MARKER" ON THE FRONT FACE OF THE DEVICE PER MANUFACTURER'S RECOMMENDATIONS. OBJECT MARKER SHALL CONFORM TO THE STANDARDS REQUIRED IN TEXAS MUTCD.
 - FOR POST (LEAVE-OUT) INSTALLATION AND GUIDANCE SEE TXDOT'S LATEST ROADWAY MOW STRIP STANDARD.
 - HARDWARE (BOLTS, NUTS, & WASHERS) SHALL BE GALVANIZED IN ACCORDANCE WITH ITEM 445, "GALVANIZING". FITTINGS SHALL BE SUBSIDIARY TO THE BID ITEM.
 - SYSTEM SHOWN USING STEEL WIDE FLANGE POSTS WITH COMPOSITE BLOCKOUTS.
 - A COMPOSITE MATERIAL BLOCKOUTS THAT MEETS THE REQUIREMENTS OF DMS-7210, MAY BE SUBSTITUTED FOR BLOCKOUTS OF SIMILAR DIMENSIONS. SEE CONSTRUCTION DIVISION MATERIAL PRODUCER LIST (MPL) FOR CERTIFIED PRODUCERS.
 - IF SOLID ROCK IS ENCOUNTERED IN THE AREA OF (POST 1) AND / OR (POST 2) CONTACT THE MANUFACTURER, & REFER TO THE LATEST ROADWAY MBSGF STANDARD FOR INSTALLATION GUIDANCE.
 - POSTS SHALL NOT BE SET IN CONCRETE.
 - SYSTEM MUST BE ATTACHED TO STANDARD 31" MBSGF.
 - UNDER NO CIRCUMSTANCES SHALL THE GUARDRAIL WITHIN THE MSKT SYSTEM BE CURVED.
 - A FLARE RATE OF UP TO 25:1 MAY BE USED TO PREVENT THE TERMINAL HEAD FROM ENCRoACHING ON THE SHOULDER. THE FLARE MAY BE DECREASED OR ELIMINATED FOR SPECIFIC INSTALLATIONS, IF DIRECTED BY THE ENGINEER.
 - THE SYSTEM IS SHOWN WITH TWO 12'-6" MBSGF PANELS, ONE 25'-0" MBSGF PANEL IS ALSO ALLOWED IN ITS PLACE.
 - A DRIVING CAP WITH A TIMBER OR PLASTIC INSERT SHALL BE USED WHEN DRIVING POSTS 3-8 TO PREVENT DAMAGE TO THE GALVANIZING ON TOP OF THE POST. SPECIAL DRIVING CAP TO BE USED ON LOWER POSTS 1 & 2 TO PREVENT DAMAGE TO THE WELDED PLATES.

ITEM	QTY	MAIN SYSTEM COMPONENTS	ITEM NUMBERS
A	1	MSKT IMPACT HEAD	MS3000
B	1	W-BEAM GUARDRAIL END SECTION, 12 Go.	SF1303
C	1	POST 1 - TOP (6" X 6" X 1/8" TUBE)	MTPHP1A
D	1	POST 1 - BOTTOM (6' W6X15)	MTPHP1B
E	1	POST 2 - ASSEMBLY TOP	UHP2A
F	1	POST 2 - ASSEMBLY BOTTOM (6' W6X9)	HP2B
G	1	BEARING PLATE	E750
H	1	CABLE ANCHOR BOX	S760
J	1	BCT CABLE ANCHOR ASSEMBLY	E770
K	1	GROUND STRUT	MS785
L	6	W6X9 OR W6X8.5 STEEL POST	P621
M	6	COMPOSITE BLOCKOUTS	CBSP-14
N	1	W-BEAM MGS RAIL SECTION (9'-4 1/2")	G12025
O	2	W-BEAM MGS RAIL SECTION (12'-6")	G1203A
P	6	WOOD BLOCKOUT 6" X 8" X 14"	P675
Q	1	W-BEAM MGS RAIL SECTION (25'-0")	G1209
SMALL HARDWARE			
o	2	5/8" x 1" HEX BOLT (GRD 5)	B5160104A
b	4	5/8" WASHER	W0516
c	2	5/8" HEX NUT	N0516
d	25	5/8" Dia. x 1 1/4" SPLICE BOLT (POST 2)	B580122
e	2	5/8" Dia. x 9" HEX BOLT (GRD A449)	B580904A
f	3	5/8" WASHER	W050
g	33	5/8" Dia. H.G.R NUT	N050
h	1	3/4" Dia. x 8 1/2" HEX BOLT (GRD A449)	B340854A
j	1	3/4" Dia. HEX NUT	N030
k	2	1 ANCHOR CABLE HEX NUT	N100
l	2	1 ANCHOR CABLE WASHER	W100
m	8	1/2" x 1 1/4" A325 BOLT WITH CAPTIVE WASHER	SB12A
n	8	1/2" STRUCTURAL NUTS	N012A
o	8	1 1/8" O.D. x 3/8" I.D. STRUCTURAL WASHERS	W012A
p	1	BEARING PLATE RETAINER TIE	CT-100ST
q	6	5/8" x 10" H.G.R. BOLT	B581002
r	1	OBJECT MARKER 18" X 18"	E3151

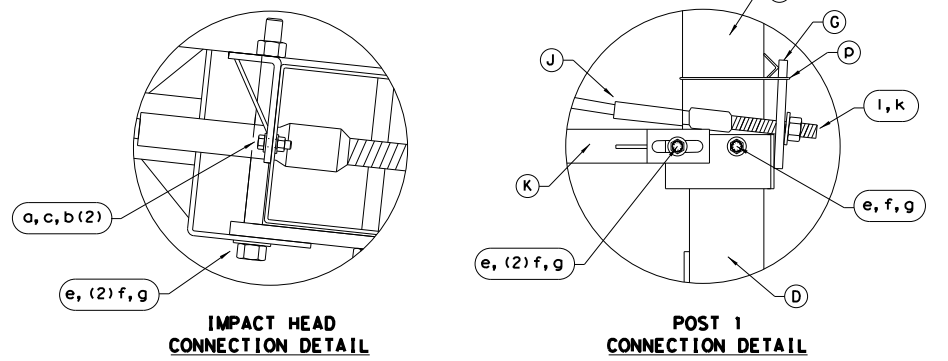
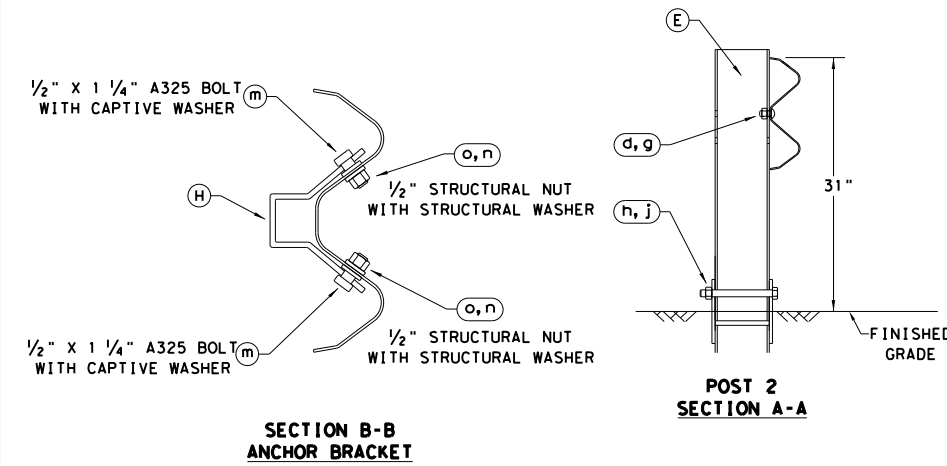

ALTERNATIVE ITEMS NOT SHOWN. *
 * ITEM (P) 8" WOOD-BLOCKOUT
 ** ITEM (Q) 25' GUARD FENCE PANEL

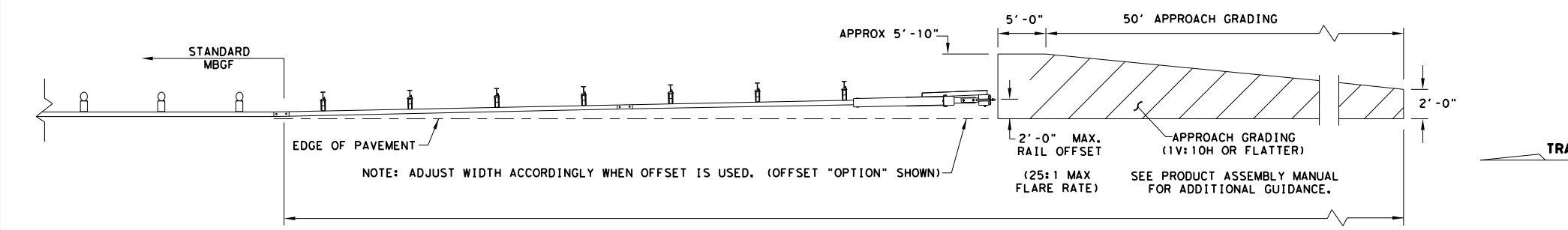

NOTE: TXDOT GENERIC APPROACH GRADING LAYOUT USED FOR ALL TANGENT TYPE END TREATMENTS.

NOTE: THIS STANDARD IS A BASIC REPRESENTATION OF THE MSKT END TERMINAL, IT IS NOT INTENDED TO REPLACE THE PRODUCT DESCRIPTION ASSEMBLY MANUAL.

Design Division Standard

SINGLE GUARDRAIL TERMINAL

MSKT-MASH-TL-3

SGT (12S) 31-18

FILE: sgt12s3118.dgn	DN: TXDOT	CK: KM	DW: VP	CK: CL
© TXDOT: APRIL 2018	CONT	SECT	JOB	HIGHWAY
REVISIONS	0095	14	033, ETC	IH 20, ETC
	DIST	COUNTY		SHEET NO.
	DAL	KAUFMAN, ETC		101

DISCLAIMER: The use of this standard is governed by the "Texas Engineering Practice Act". No warranty of any kind is made by TxDOT for any purpose whatsoever. TxDOT assumes no responsibility for the conversion of units or for any errors or damages resulting from its use.

DATE: 3/11/2023 4:31:59 PM
 FILE: T:\DAL\TRAFM\FY_2023_PS&E\I.H. 20\Plan Set\Standards\non-paf_standards\Types S and N.dwg

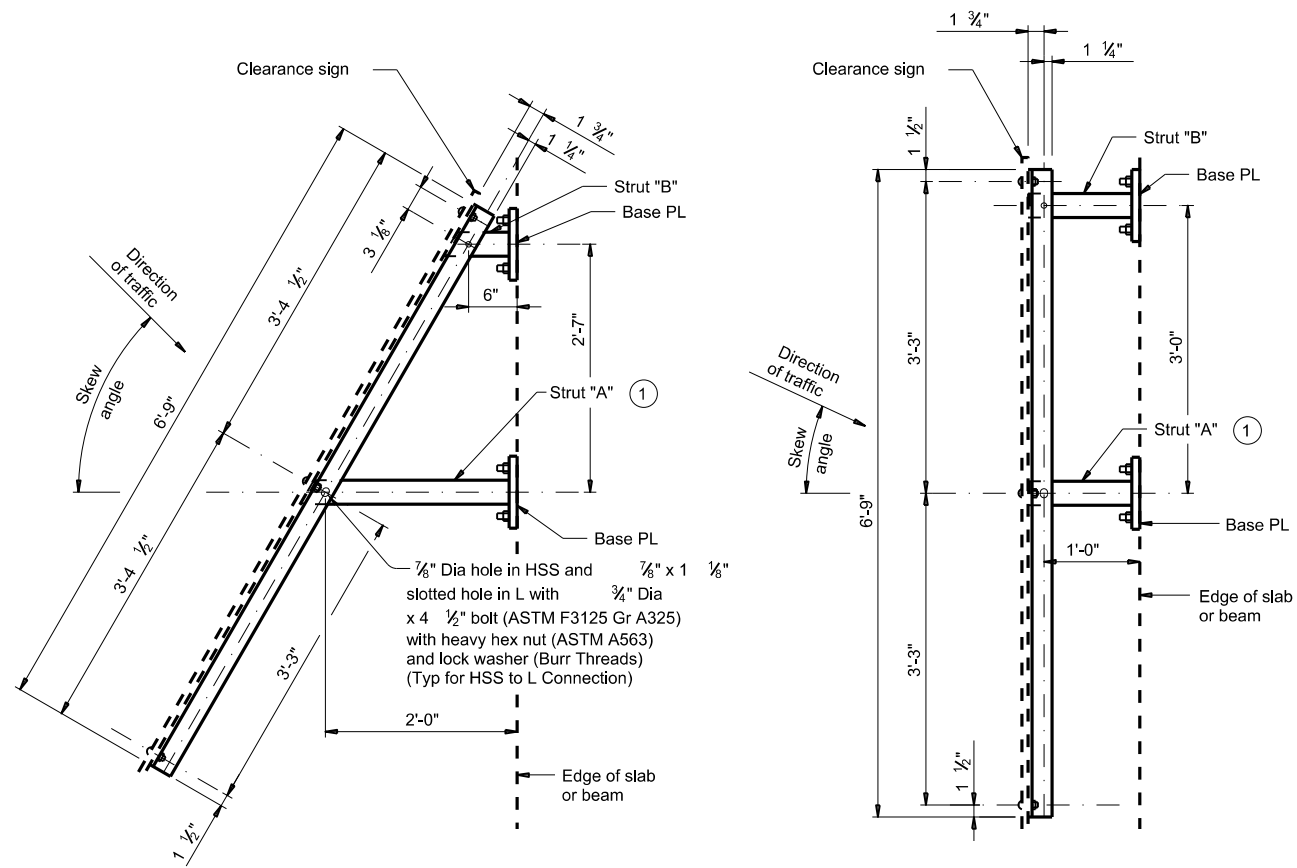

PLAN OF TYPE S MOUNT
 (Used for skews over 30°)

PLAN OF TYPE N MOUNT
 (Used for 0° to 30° skews)

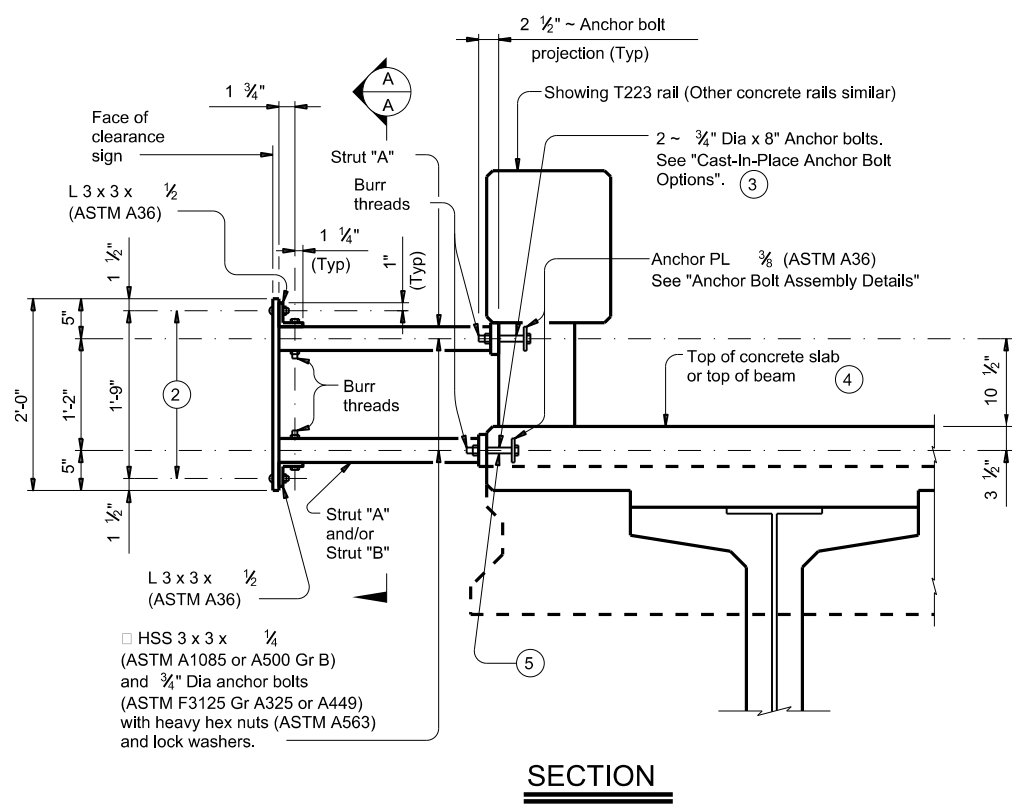

SECTION

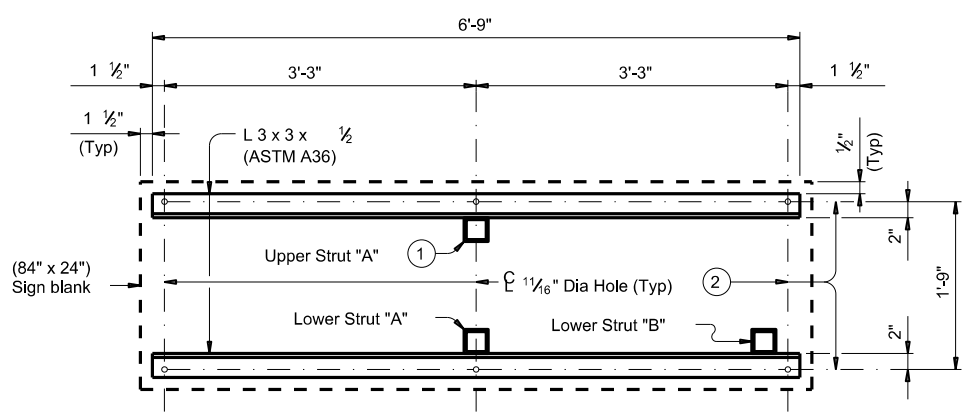

SECTION A-A

- ① Locate centerline of Strut A no closer than 12" from a vertical concrete edge.
- ② $\frac{5}{8}$ " Dia x 2" Hexagon socket button head cap screws (ASTM A574) with hex nuts. Attach hex nuts to L 3 x 3 x $\frac{1}{2}$ " by tack welding in two places. Threads must have Class 3A fit tolerance in accordance ASME B1.1. Six screws required.
- ③ At the Contractor's option fully threaded adhesive anchors may be used instead of cast-in-place anchor bolts. Expansion anchors are not allowed. Provide adhesive anchors that are $\frac{3}{4}$ " Dia ASTM A193 Gr B7 or F1554 Gr 105 fully threaded rods with one hardened steel washer (ASTM F436) and one regular lock washer placed under heavy hex nut (ASTM A563). Embed fully threaded rods using a Type III, Class C, D, E, or F anchor adhesive. Adhesive anchor embedment depth is 8". Anchor adhesive chosen must be able to achieve a factored bond strength in tension of 2.2 kips per anchor (edge distance and spacing must be accounted for). Submit signed and sealed calculations or the manufacturer's published literature showing the proposed anchor adhesive's ability to develop this load to the Engineer for approval prior to use. Anchor installation, including hole size, drilling, and clean out, must be in accordance with Item 450, "Railing".
- ④ For decked slab beams topped with a 2 course surface treatment and ACP overlay.
- ⑤ Anchor bolts to be cast into decked slab beams topped with a 2 course surface treatment or ACP overlay. Anchor bolts with heavy hex nuts, regular lock washers, hardened washers and anchor plate that is embedded in the beam will be provided by the beam Fabricator.

CONSTRUCTION NOTES:
 Install the vertical face of clearance sign plumb unless otherwise approved by the Engineer.
 Test adhesive anchors in accordance with Item 450.3.3, "Tests". Test 1 anchor per bridge mounted clearance sign installed. Perform corrective measures to provide adequate capacity if any of the tests do not meet the required test load. Repair damage from testing as directed.

MATERIAL NOTES:
 Galvanize all steel components after fabrication unless otherwise noted.

GENERAL NOTES:
 This standard provides details to mount a vertical clearance sign (84" x 24") to bridges. Rail Types T631, T631LS, PR11, PR22 and PR3 are not accommodated. The Engineer will furnish the clearance to be shown on the sign.
 See Bridge Layout for sign location and mounting type (Type N or S).
 Cost of furnishing, installing, relocating or removing a clearance sign, including structural steel for sign mount, is included in unit price bid for Item 644, "Small Roadside Sign Assemblies".
 One Sign Blank (84" x 24") is 14 SF.
 Average steel weight for one complete Type N Mount is 219 Lb.
 Average steel weight for one complete Type S Mount is 233 Lb.

SHEET 1 OF 3

		Bridge Division Standard	
BRIDGE MOUNTED CLEARANCE SIGN ASSEMBLY			
BMCS			
FILE: bmcste1-19.dgn	DN: TxDOT	CK: TxDOT	DW: TxDOT
©TxDOT April 2019	CONT	SECT	JOB
REVISIONS	0095 14	033, ETC	IH 20, ETC
DIST	COUNTY	SHEET NO.	
DAL	KAUFMAN, ETC	102	

DISCLAIMER: The use of this standard is governed by the "Texas Engineering Practice Act". No warranty of any kind is made by TxDOT for any purpose whatsoever. TxDOT assumes no responsibility for the conversion of units or for any errors or omissions in this standard or for any damages resulting from its use.

DATE: 3/1/2023 4:32:00 PM
 FILE: T:\DAL\TRAFFIC\2023 PS&E\1H_20\Plan_Sets\Standards\Non-paf_standards\BMCSS\BMCSS.dwg

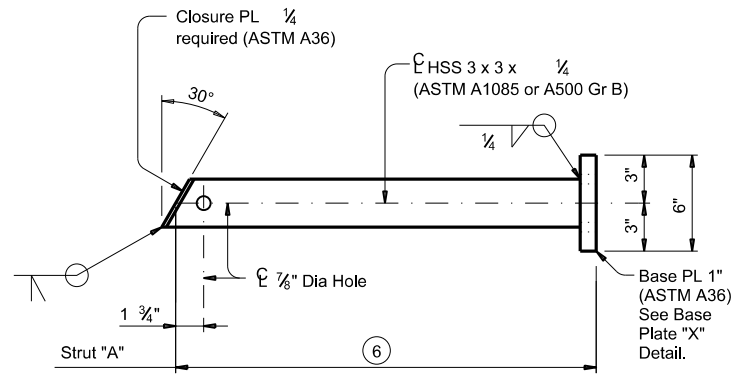

FOR T411 AND C411 RAIL TYPES

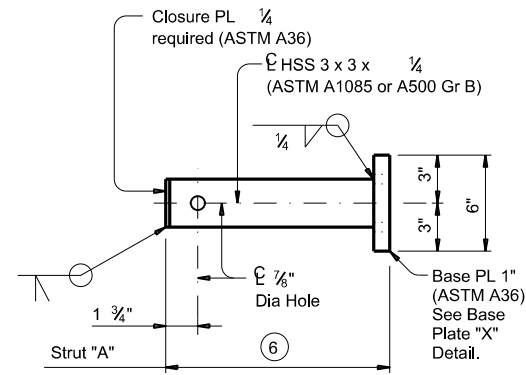

FOR T411 AND C411 RAIL TYPES

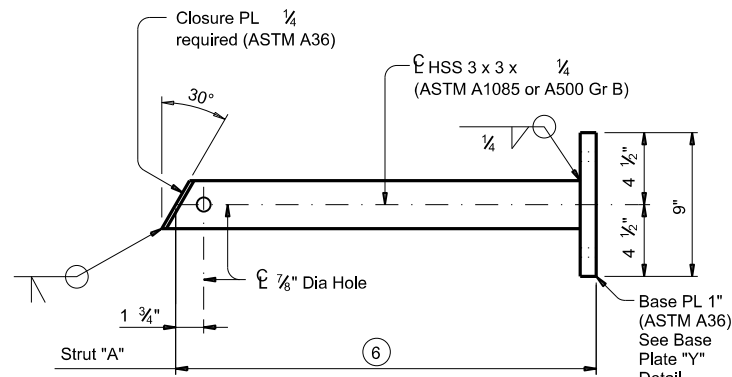

FOR T221, C221, T222, T223, C223, T401, T402, C402, T551, T552, T80HT, T80SS AND SSTR RAIL TYPES

UPPER STRUT DETAIL FOR (TYPE S MOUNT)

(Used for skews over 30°)

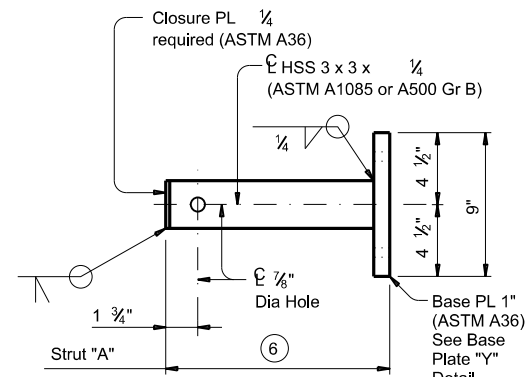

FOR T221, C221, T222, T223, C223, T401, T402, C402, T551, T552, T80HT, T80SS AND SSTR RAIL TYPES

UPPER STRUT DETAIL FOR (TYPE N MOUNT)

(Used for 0° to 30° skews)

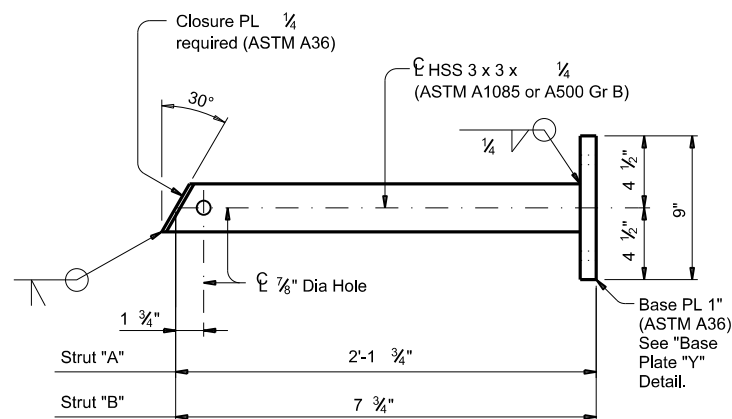

LOWER STRUT DETAILS FOR (TYPE S MOUNT)

(Used for skews over 30°)

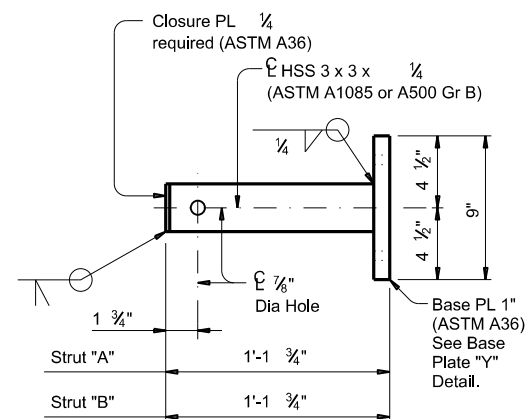

LOWER STRUT DETAILS FOR (TYPE N MOUNT)

(Used for 0° to 30° skews)

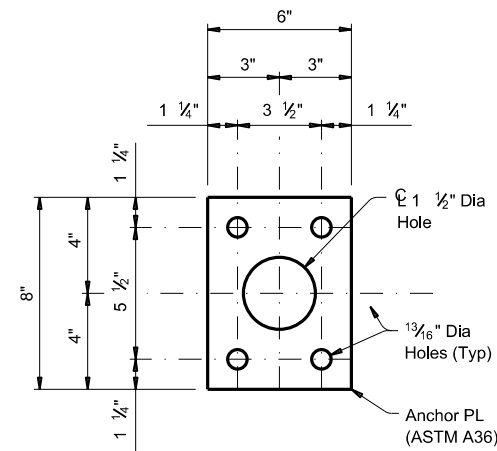

PLAN OF ANCHOR PLATE

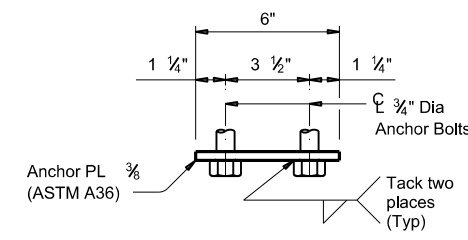

ANCHOR BOLT ASSEMBLY DETAILS

(Used on Base Plate "X" with T411 and C411 rail types.)

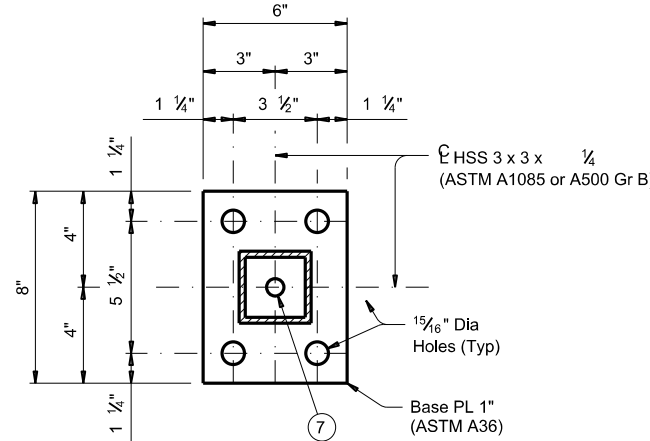

BASE PLATE "X" DETAIL

3/4" Dia heavy hex head anchor bolt (ASTM F3125 Gr A325 or A449) or threaded rod (ASTM A193 Gr B7 or F1554 Gr 105) with one hardened washer and one regular lock washer placed under heavy hex nut (ASTM A563). Furnish one additional heavy hex nut for each threaded rod.

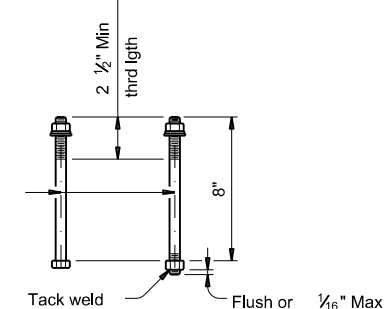

CAST-IN-PLACE ANCHOR BOLT OPTIONS

- 3 At the Contractor's option fully threaded adhesive anchors may be used instead of cast-in-place anchor bolts. Expansion anchors are not allowed. Provide adhesive anchors that are ASTM A193 Gr B7 or F1554 Gr 105 fully threaded rods with one hardened steel washer (ASTM F436) and one regular lock washer placed under heavy hex nut (ASTM A563). Embed fully threaded rods using a Type III, Class C, D, E, or F anchor adhesive. Adhesive anchor embedment depth is 8". Anchor adhesive chosen must be able to achieve a factored bond strength in tension of 2.2 kips per anchor (edge distance and spacing must be accounted for). Submit signed and sealed calculations or the manufacturer's published literature showing the proposed anchor adhesive's ability to develop this load to the Engineer for approval prior to use. Anchor installation, including hole size, drilling, and clean out, must be in accordance with Item 450, "Railing".
- 6 Adjust length to accommodate edge of slab to back of rail for specific project conditions and to help plumb the vertical face of clearance sign.
- 7 Hole required to drain zinc from base plate during galvanizing.

3/4" Dia

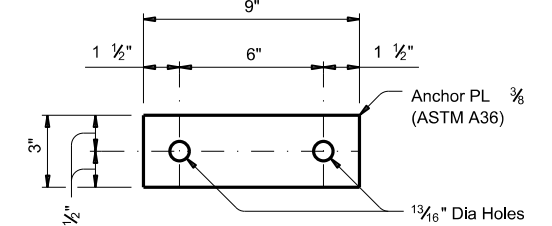

PLAN OF ANCHOR PLATE

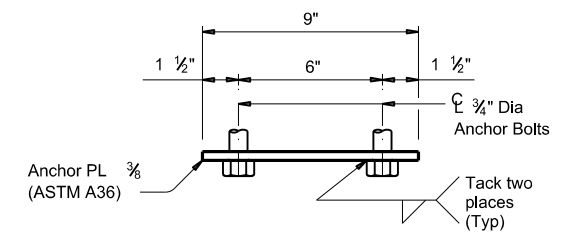

ANCHOR BOLT ASSEMBLY DETAILS

(Used on Base Plate "Y" and with T1F, T2P, C2P, T1W, C1W, T66 and C66 rail types.)

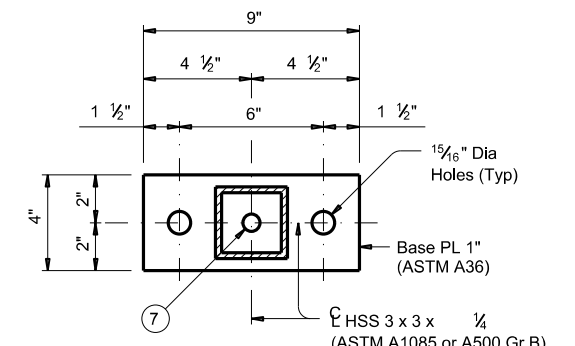

BASE PLATE "Y" DETAIL

SHEET 2 OF 3

				Bridge Division Standard	
<h2>BRIDGE MOUNTED CLEARANCE SIGN ASSEMBLY</h2>					
<h3>BMCS</h3>					
FILE: bmcste1-19.dgn	DN: TxDOT	CK: TxDOT	DW: TxDOT	CK: TxDOT	
©TxDOT April 2019	CONT	SECT	JOB	HIGHWAY	
REVISIONS	0095	14	033, ETC	IH 20, ETC	
DIST	COUNTY			SHEET NO.	
DAL	KAUFMAN, ETC			103	

DATE: 3/1/2023 4:32:01 PM
 FILE: T:\DAL\TRAFFIC\2023 PS&E\I.H. 20\Plan Set\standards\non-pdf standards\bridge mounted clearance sign assembly.dwg
 DISCLAIMER: The use of this standard is governed by the "Texas Engineering Practice Act". No warranty of any kind is made by TxDOT for any purpose whatsoever. TxDOT assumes no responsibility for the conversion or damages resulting from its use.

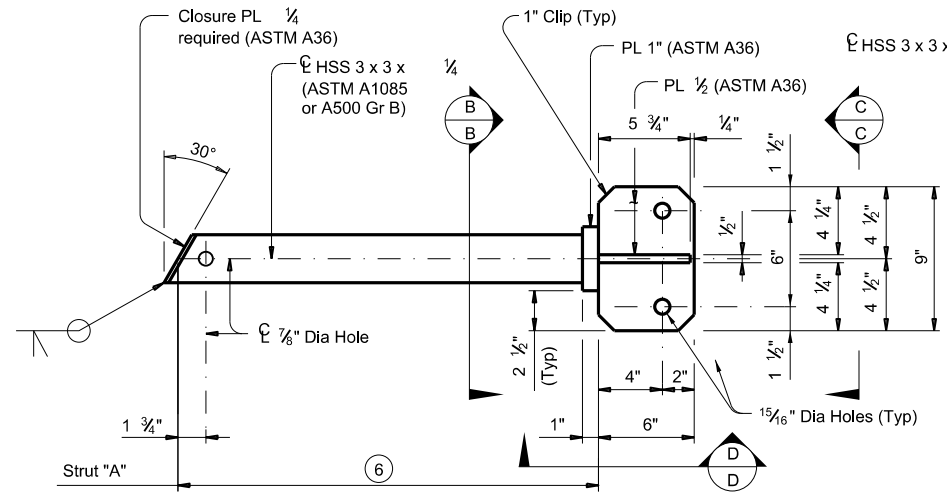

FOR T1F, T2P, C2P, T1W, C1W, T66 AND C66 RAIL TYPES

UPPER STRUT DETAIL FOR (TYPE S MOUNT)

(Used for skewes over 30°)

- ② $\frac{5}{8}$ " Dia x 2" Hexagon socket button head cap screws (ASTM A574) with hex nuts. Attach hex nuts to L 3 x 3 x $\frac{1}{2}$ " by tack welding in two places. Threads must have Class 3A fit tolerance in accordance ASME B1.1. Six screws required.
- ③ At the Contractor's option fully threaded adhesive anchors may be used instead of cast-in-place anchor bolts. Expansion anchors are not allowed. Provide adhesive anchors that are ASTM A193 Gr B7 or F1554 Gr 105 fully threaded rods with one hardened steel washer (ASTM F436) and one regular lock washer placed under heavy hex nut (ASTM A563). Embed fully threaded rods using a Type III, Class C, D, E, or F anchor adhesive. Adhesive anchor embedment depth is 8". Anchor adhesive chosen must be able to achieve a factored bond strength in tension of 2.2 kips per anchor (edge distance and spacing must be accounted for). Submit signed and sealed calculations or the manufacturer's published literature showing the proposed anchor adhesive's ability to develop this load to the Engineer for approval prior to use. Anchor installation, including hole size, drilling, and clean out, must be in accordance with Item 450, "Railing".

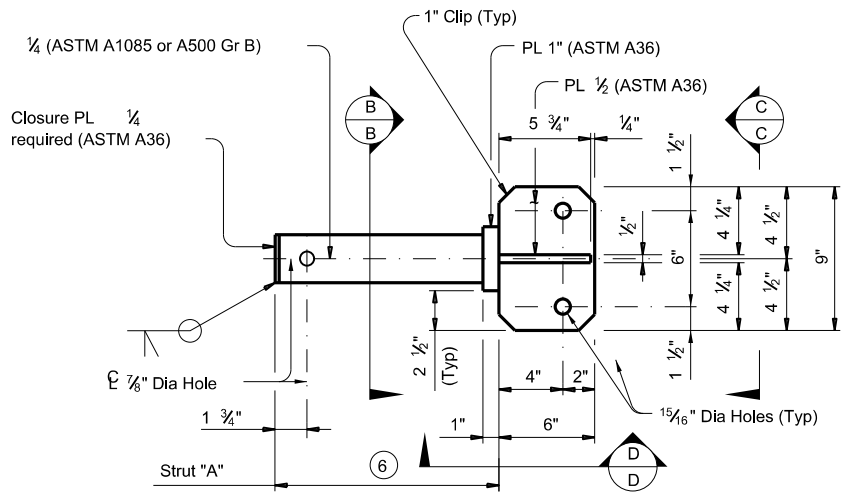

FOR T1F, T2P, C2P, T1W, C1W, T66 AND C66 RAIL TYPES

UPPER STRUT DETAIL FOR (TYPE N MOUNT)

(Used for 0° to 30° skewes)

- ④ For decked slab beams topped with a 2 course surface treatment and ACP overlay.
- ⑥ Adjust length to accommodate edge of slab to back of rail for specific project conditions and to help plumb the vertical face of clearance sign.
- ⑧ Hole required in bottom of HSS to drain zinc during galvanizing.
- ⑨ 11" curb is for structures with 2" ACP overlay.

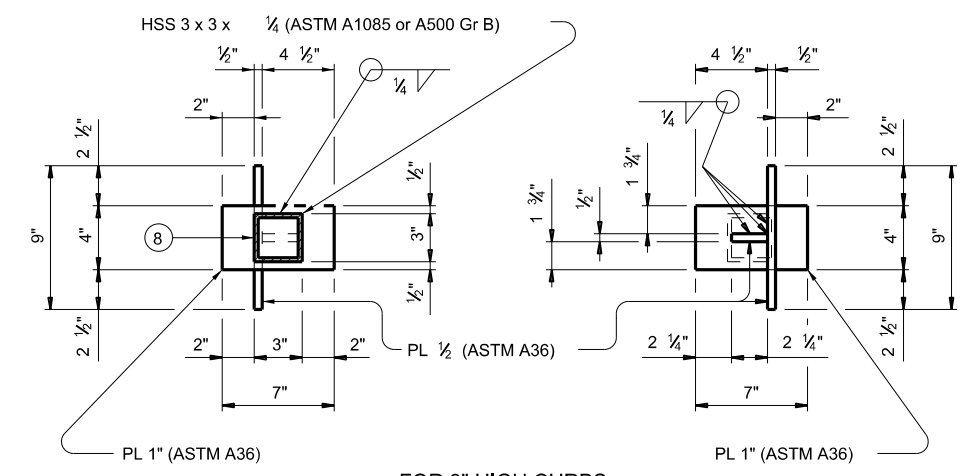

FOR 9" HIGH CURBS

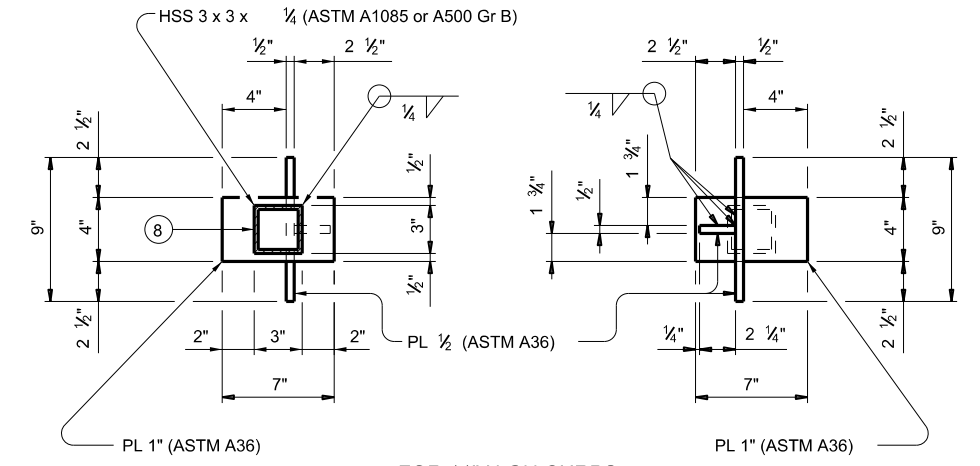

SECTION B-B

VIEW C-C

FOR 11" HIGH CURBS

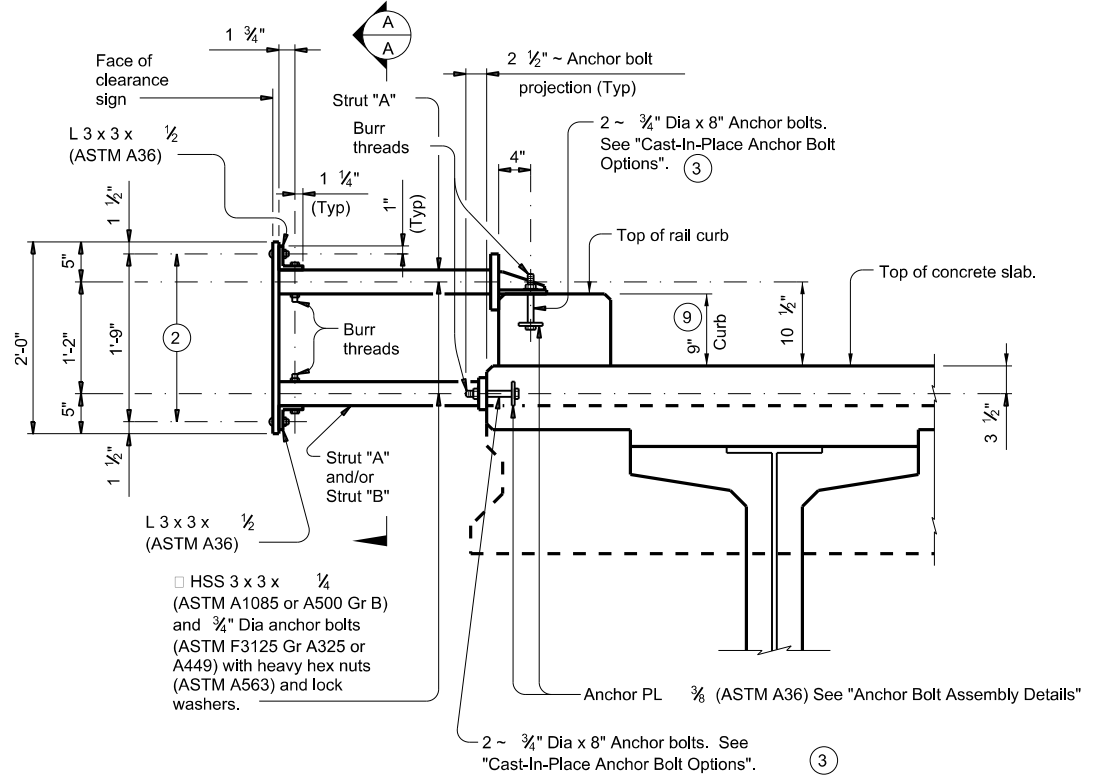

SECTION THRU T1F, T2P, C2P, T1W, C1W, T66 AND C66 RAIL CURB

Showing sign mount on a 9" high curb, 11" high curb similar.

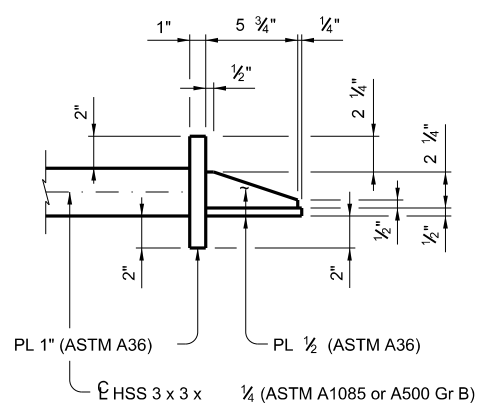

FOR 9" HIGH CURBS

VIEW D-D

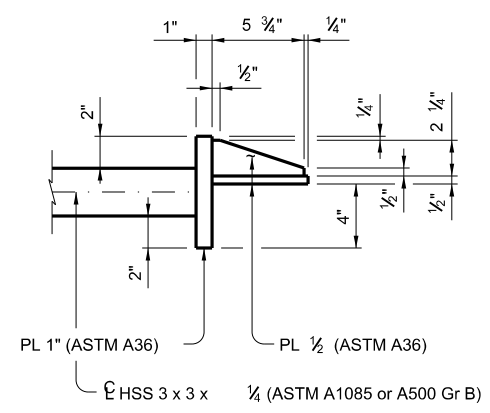

FOR 11" HIGH CURBS

SHEET 3 OF 3

		Bridge Division Standard	
<h2 style="margin: 0;">BRIDGE MOUNTED CLEARANCE SIGN ASSEMBLY</h2>			
<h3 style="margin: 0;">BMCS</h3>			
FILE: bmcste1-19.dgn	DN: TxDOT	CK: TxDOT	DW: TxDOT
©TxDOT April 2019	CON: 0095	SECT: 14	JOB: 033, ETC
REVISIONS	HIGHWAY: IH 20, ETC		SHEET NO. 104
DIST: DAL	COUNTY: KAUFMAN, ETC	SHEET NO. 104	

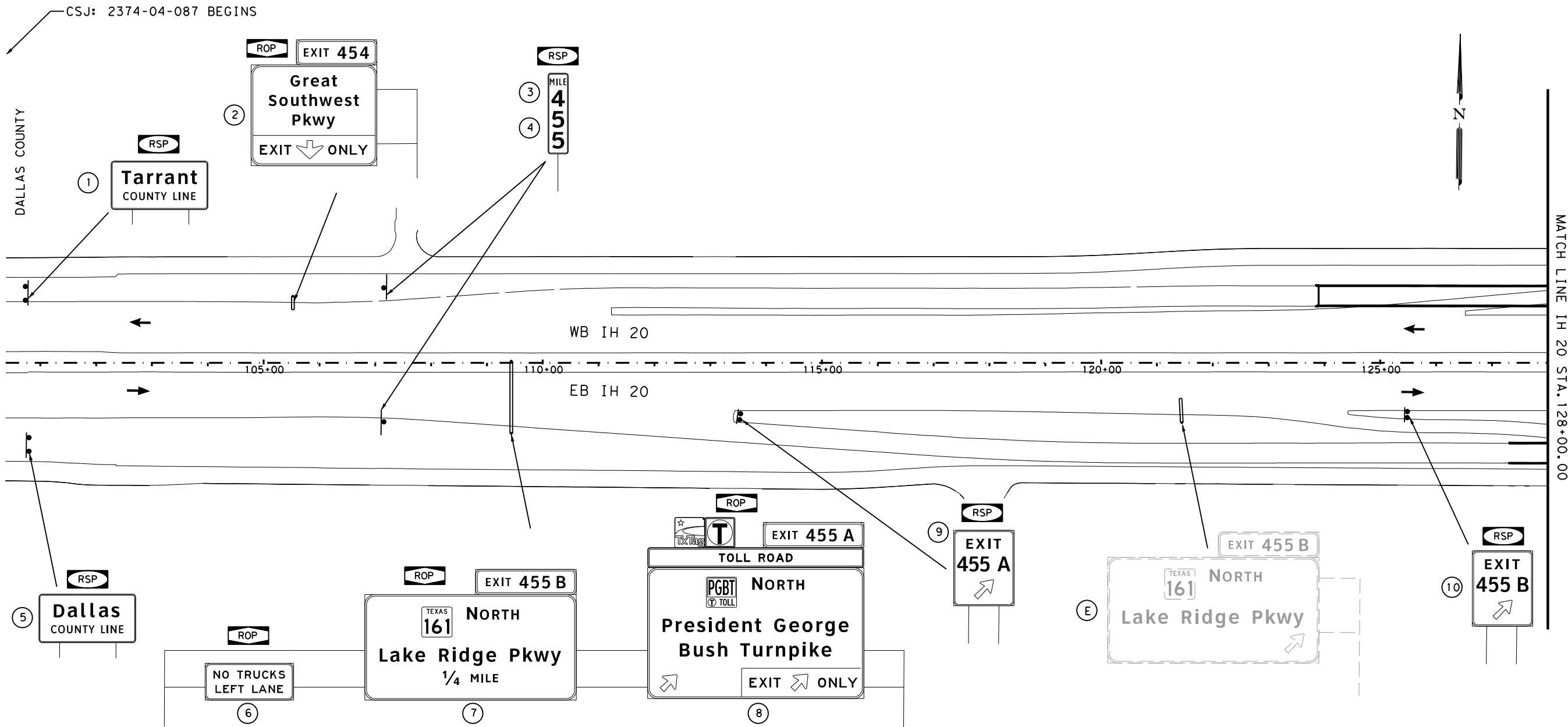

SIGNING LEGEND

- (E) EXISTING SIGN TO REMAIN
 - (3) SIGN TO BE INSTALLED
 - RSA REMOVE SMALL SIGN ASSEMBLY
 - RLA-1 REMOVE LARGE GROUND ASSEMBLY
 - RSP REPLACE SMALL SIGN PANEL
 - RLP REPLACE LARGE SIGN PANEL
 - ROP REPLACE OVERHEAD PANEL
 - ROS-1 REMOVE OVERHEAD STRUCTURE
-
- * REMOVAL ITEMS THIS SHEET
 - (EA) SMALL SIGNS ASSEMBLY
 - (EA) OVERHEAD SIGNS
 - (EA) LARGE SIGNS ASSEMBLY
 - (EA) WALKWAY
 - * Removal Quantities are Approximate and Contractor Will be Paid For Actual Work Performed

INSTALL PROPOSED SIGNS
1 FT TO 2 FT BEHIND EXISTING
SIGN LOCATION,
UNLESS OTHERWISE NOTED.

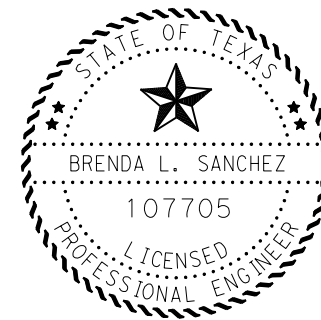

Brenda L Sanchez, P.E. 03/20/23
Signature of Registrant & Date



Texas Department of Transportation
© 2023

SIGNING LAYOUT IH 20

SCALE: 1"=200' SHEET 1 OF 121

DESIGN/CK BLS	FED. RD. DIV. NO. 6	STATE PROJECT NO. (SEE TITLE SHEET)		HIGHWAY NO. IH 20
CHECK BLS	STATE	DISTRICT	COUNTY	SHEET NO.
CHECK MA	TEXAS	DAL	VARIOUS	105
CHECK BA	CONTROL	SECTION	JOB	
	0095	14	033, ETC	

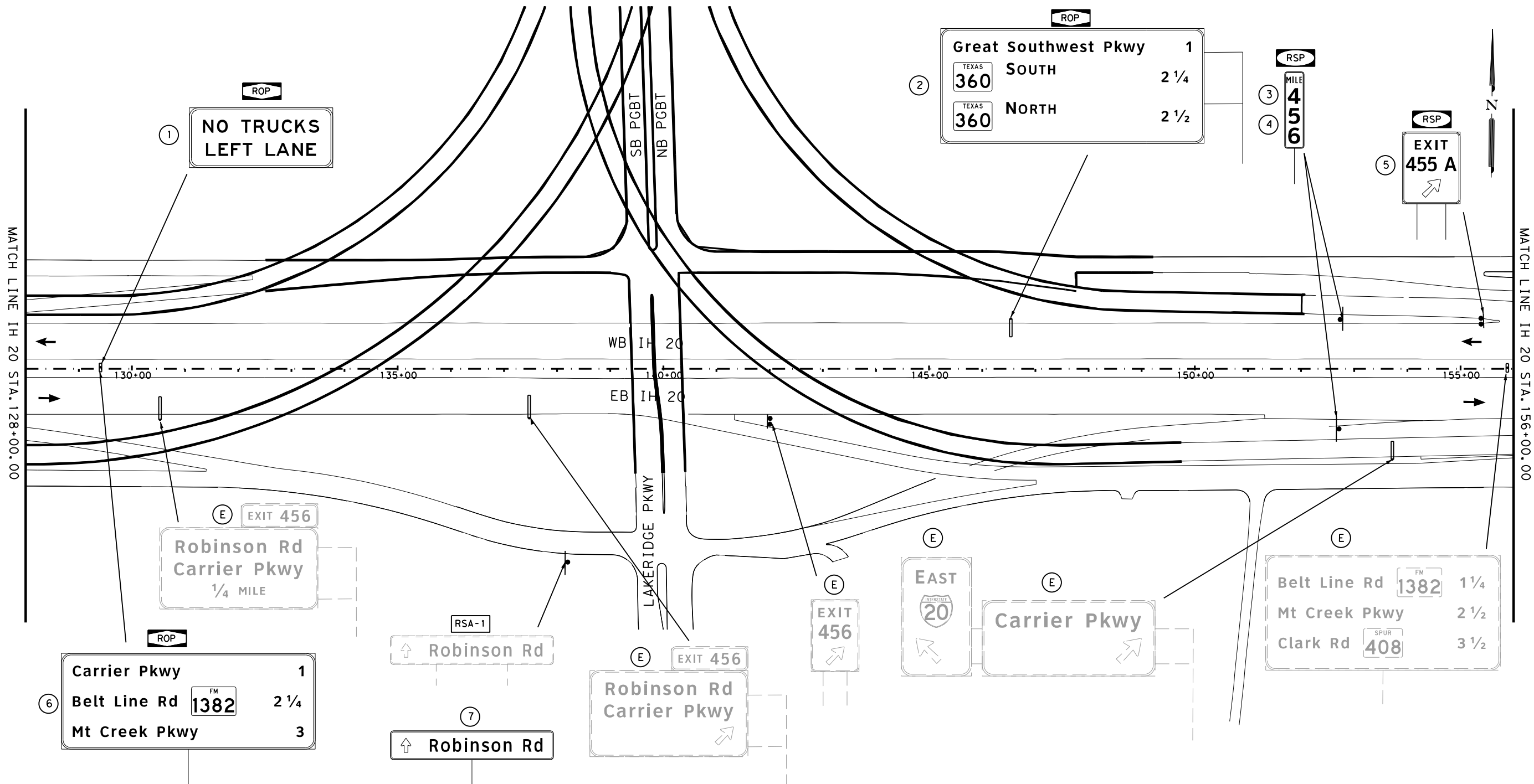

SIGNING LEGEND

- (E) EXISTING SIGN TO REMAIN
- (3) SIGN TO BE INSTALLED
- RSA REMOVE SMALL SIGN ASSEMBLY
- RLA-1 REMOVE LARGE GROUND ASSEMBLY
- RSP REPLACE SMALL SIGN PANEL
- RLP REPLACE LARGE SIGN PANEL
- ROP REPLACE OVERHEAD PANEL
- ROS-1 REMOVE OVERHEAD STRUCTURE

- * REMOVAL ITEMS THIS SHEET
- (EA) SMALL SIGNS ASSEMBLY
 - (EA) OVERHEAD SIGNS
 - (EA) LARGE SIGNS ASSEMBLY
 - (EA) WALKWAY
- * Removal Quantities are Approximate and Contractor Will be Paid For Actual Work Performed

INSTALL PROPOSED SIGNS
1 FT TO 2 FT BEHIND EXISTING
SIGN LOCATION,
UNLESS OTHERWISE NOTED.



Brenda L Sanchez, P.E. 03/20/23
Signature of Registrant & Date



**SIGNING LAYOUT
IH 20**

SCALE: 1"=200' SHEET 2 OF 121

DESIGN/CK	FED. RD. DIV. NO.	STATE PROJECT NO.		HIGHWAY NO.
BLS	6	(SEE TITLE SHEET)		IH 20
CHECK	STATE	DISTRICT	COUNTY	SHEET NO.
BLS	TEXAS	DAL	VARIOUS	106
CHECK	CONTROL	SECTION	JOB	
BA	0095	14	033, ETC	

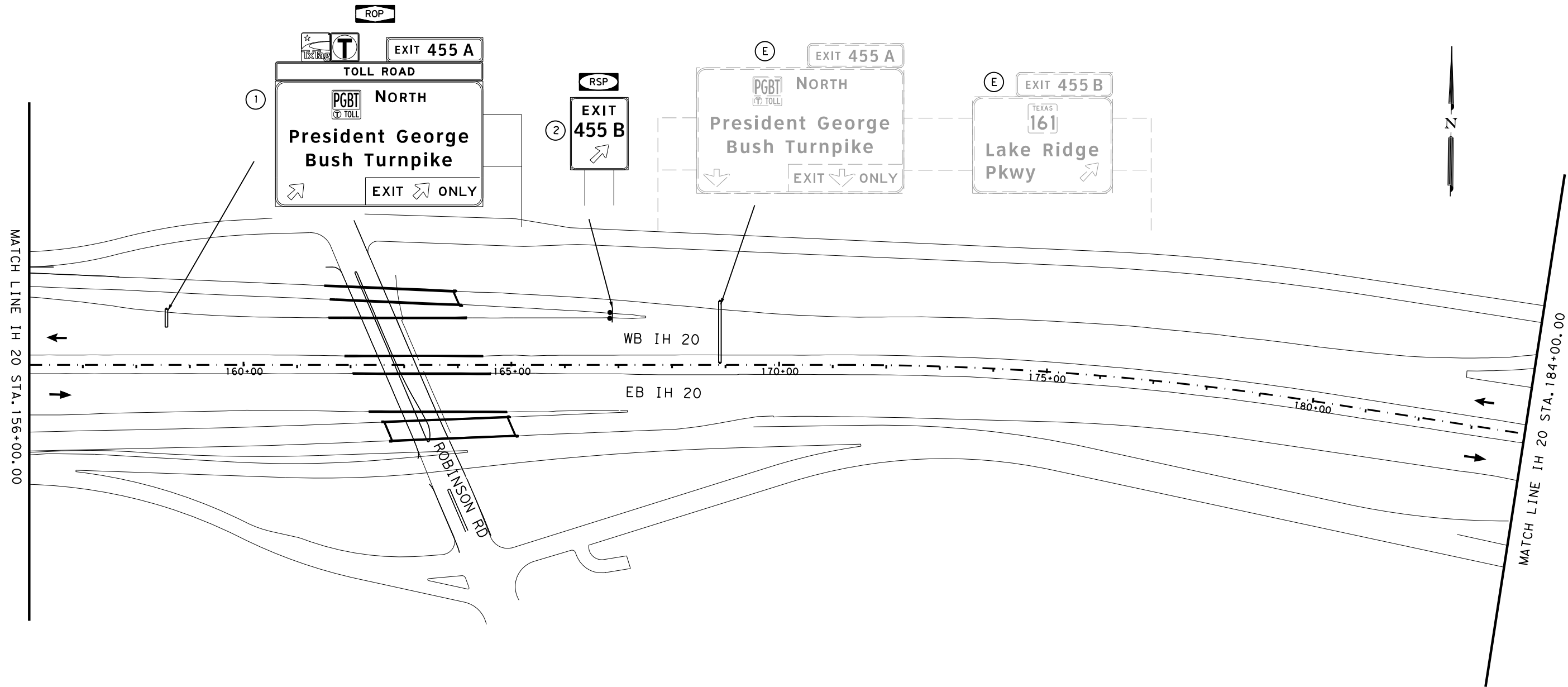

SIGNING LEGEND

- (E) EXISTING SIGN TO REMAIN
 - (3) SIGN TO BE INSTALLED
 - RSA REMOVE SMALL SIGN ASSEMBLY
 - RLA-1 REMOVE LARGE GROUND ASSEMBLY
 - RSP REPLACE SMALL SIGN PANEL
 - RLP REPLACE LARGE SIGN PANEL
 - ROP REPLACE OVERHEAD PANEL
 - ROS-1 REMOVE OVERHEAD STRUCTURE
-
- * REMOVAL ITEMS THIS SHEET
 - (EA) SMALL SIGNS ASSEMBLY
 - (EA) OVERHEAD SIGNS
 - (EA) LARGE SIGNS ASSEMBLY
 - (EA) WALKWAY
 - * Removal Quantities are Approximate and Contractor Will be Paid For Actual Work Performed

INSTALL PROPOSED SIGNS
1 FT TO 2 FT BEHIND EXISTING
SIGN LOCATION,
UNLESS OTHERWISE NOTED.



Brenda L Sanchez, P.E. 03/20/23
Signature of Registrar & Date



**SIGNING LAYOUT
IH 20**

SCALE: 1"=200' SHEET 3 OF 121

DESIGN/CK	FED. RD. DIV. NO.	STATE PROJECT NO.		HIGHWAY NO.
BLS	6	(SEE TITLE SHEET)		IH 20
CHECK	STATE	DISTRICT	COUNTY	SHEET NO.
BLS	TEXAS	DAL	VARIOUS	107
CHECK	CONTROL	SECTION	JOB	
BA	0095	14	033, ETC	

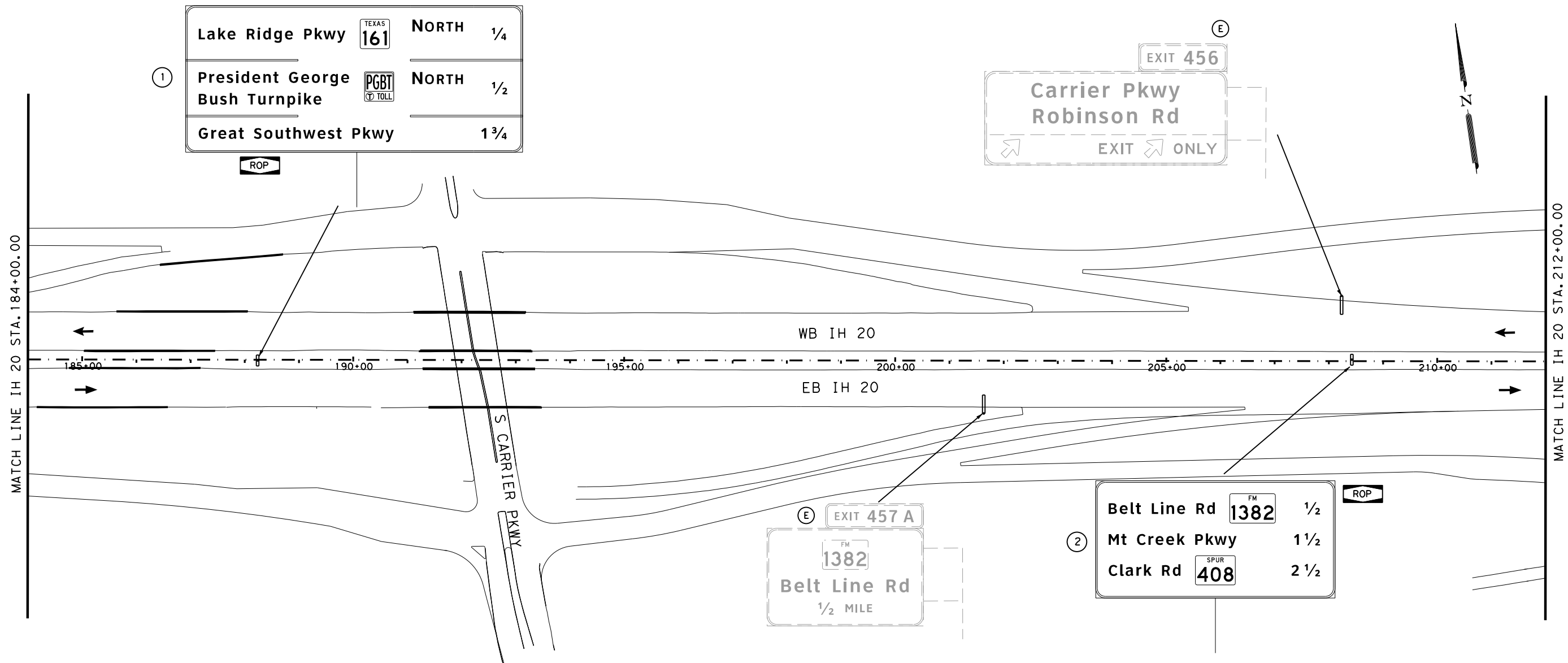

SIGNING LEGEND

- (E) EXISTING SIGN TO REMAIN
 - (3) SIGN TO BE INSTALLED
 - RSA REMOVE SMALL SIGN ASSEMBLY
 - RLA-1 REMOVE LARGE GROUND ASSEMBLY
 - RSP REPLACE SMALL SIGN PANEL
 - RLP REPLACE LARGE SIGN PANEL
 - ROP REPLACE OVERHEAD PANEL
 - ROS-1 REMOVE OVERHEAD STRUCTURE
-
- * REMOVAL ITEMS THIS SHEET
 - (EA) SMALL SIGNS ASSEMBLY
 - (EA) OVERHEAD SIGNS
 - (EA) LARGE SIGNS ASSEMBLY
 - (EA) WALKWAY
 - * Removal Quantities are Approximate and Contractor Will be Paid For Actual Work Performed

INSTALL PROPOSED SIGNS
1 FT TO 2 FT BEHIND EXISTING
SIGN LOCATION,
UNLESS OTHERWISE NOTED.



Brenda L Sanchez, P.E. 03/20/23
Signature of Registrar & Date

Texas Department of Transportation
© 2023

SIGNING LAYOUT IH 20

SCALE: 1"=200' SHEET 4 OF 121

DESIGN/CK BLS	FED. RD. DIV. NO. 6	STATE PROJECT NO. (SEE TITLE SHEET)		HIGHWAY NO. IH 20
CHECK BLS	STATE	DISTRICT	COUNTY	SHEET NO.
CHECK MA	TEXAS	DAL	VARIOUS	108
CHECK BA	CONTROL	SECTION	JOB	
	0095	14	033, ETC	

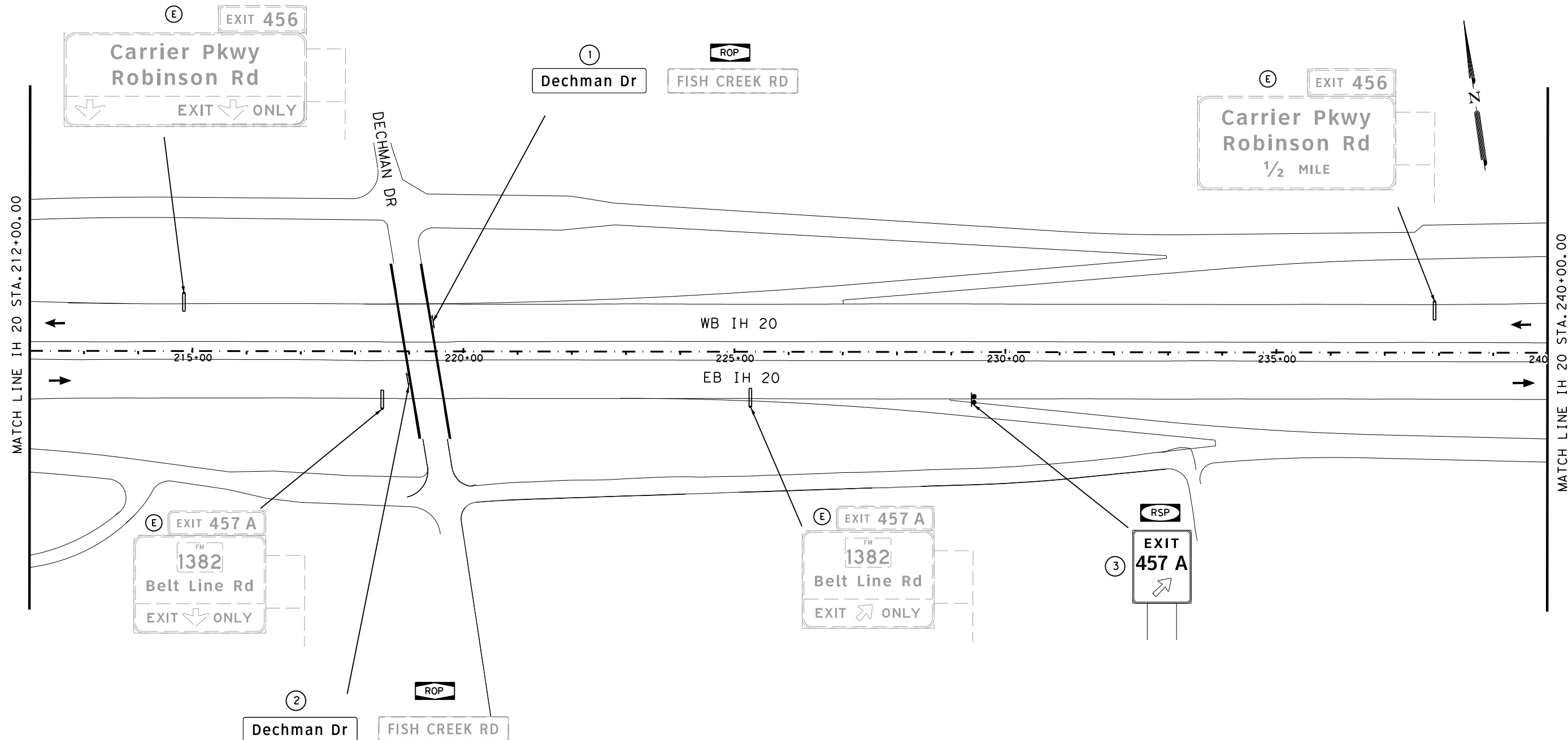

SIGNING LEGEND

- (E) EXISTING SIGN TO REMAIN
 - (3) SIGN TO BE INSTALLED
 - RSA REMOVE SMALL SIGN ASSEMBLY
 - RLA-1 REMOVE LARGE GROUND ASSEMBLY
 - RSP REPLACE SMALL SIGN PANEL
 - RLP REPLACE LARGE SIGN PANEL
 - ROP REPLACE OVERHEAD PANEL
 - ROS-1 REMOVE OVERHEAD STRUCTURE
-
- * REMOVAL ITEMS THIS SHEET
 - (EA) SMALL SIGNS ASSEMBLY
 - (EA) OVERHEAD SIGNS
 - (EA) LARGE SIGNS ASSEMBLY
 - (EA) WALKWAY
 - * Removal Quantities are Approximate and Contractor Will be Paid For Actual Work Performed

INSTALL PROPOSED SIGNS
1 FT TO 2 FT BEHIND EXISTING
SIGN LOCATION,
UNLESS OTHERWISE NOTED.

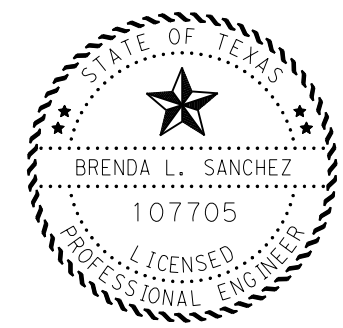

Brenda L Sanchez, P.E. 03/20/23
Signature of Registrar & Date



**SIGNING LAYOUT
IH 20**

SCALE: 1"=200' SHEET 5 OF 121

DESIGN/CK	FED. RD. DIV. NO.	STATE PROJECT NO.		HIGHWAY NO.
BLS	6	(SEE TITLE SHEET)		IH 20
CHECK	STATE	DISTRICT	COUNTY	SHEET NO.
BLS	TEXAS	DAL	VARIOUS	109
CHECK	CONTROL	SECTION	JOB	
BA	0095	14	033, ETC	

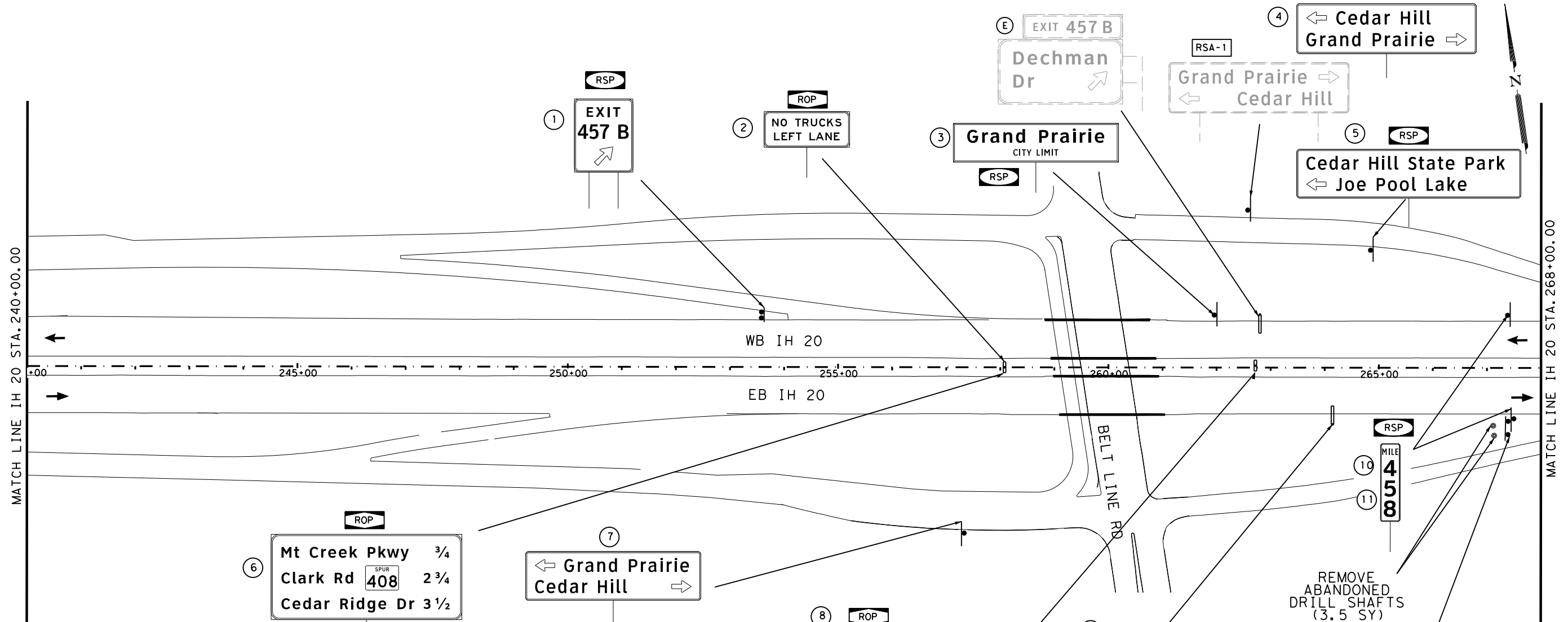

SIGNING LEGEND

- (E) EXISTING SIGN TO REMAIN
 - (3) SIGN TO BE INSTALLED
 - RSA REMOVE SMALL SIGN ASSEMBLY
 - RLA-1 REMOVE LARGE GROUND ASSEMBLY
 - RSP REPLACE SMALL SIGN PANEL
 - RLP REPLACE LARGE SIGN PANEL
 - ROP REPLACE OVERHEAD PANEL
 - ROS-1 REMOVE OVERHEAD STRUCTURE
-
- * REMOVAL ITEMS THIS SHEET
 - (EA) SMALL SIGNS ASSEMBLY
 - (EA) OVERHEAD SIGNS
 - (EA) LARGE SIGNS ASSEMBLY
 - (EA) WALKWAY
 - * Removal Quantities are Approximate and Contractor Will be Paid For Actual Work Performed

INSTALL PROPOSED SIGNS
1 FT TO 2 FT BEHIND EXISTING
SIGN LOCATION,
UNLESS OTHERWISE NOTED.

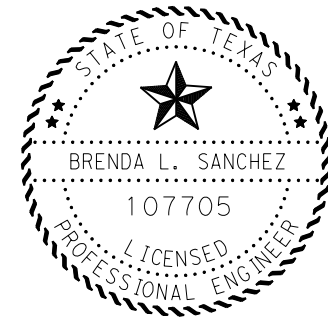

Brenda L. Sanchez, P.E. 03/20/23
Signature of Registrar & Date



**SIGNING LAYOUT
IH 20**

SCALE: 1"=200' SHEET 6 OF 121

DESIGN/CK BLS	FED. RD. DIV. NO. 6	STATE PROJECT NO. (SEE TITLE SHEET)		HIGHWAY NO. IH 20
CHECK BLS	STATE	DISTRICT DAL	COUNTY VARIOUS	SHEET NO. 110
CHECK MA	CONTROL	SECTION	JOB	
CHECK BA	0095	14	033, ETC	

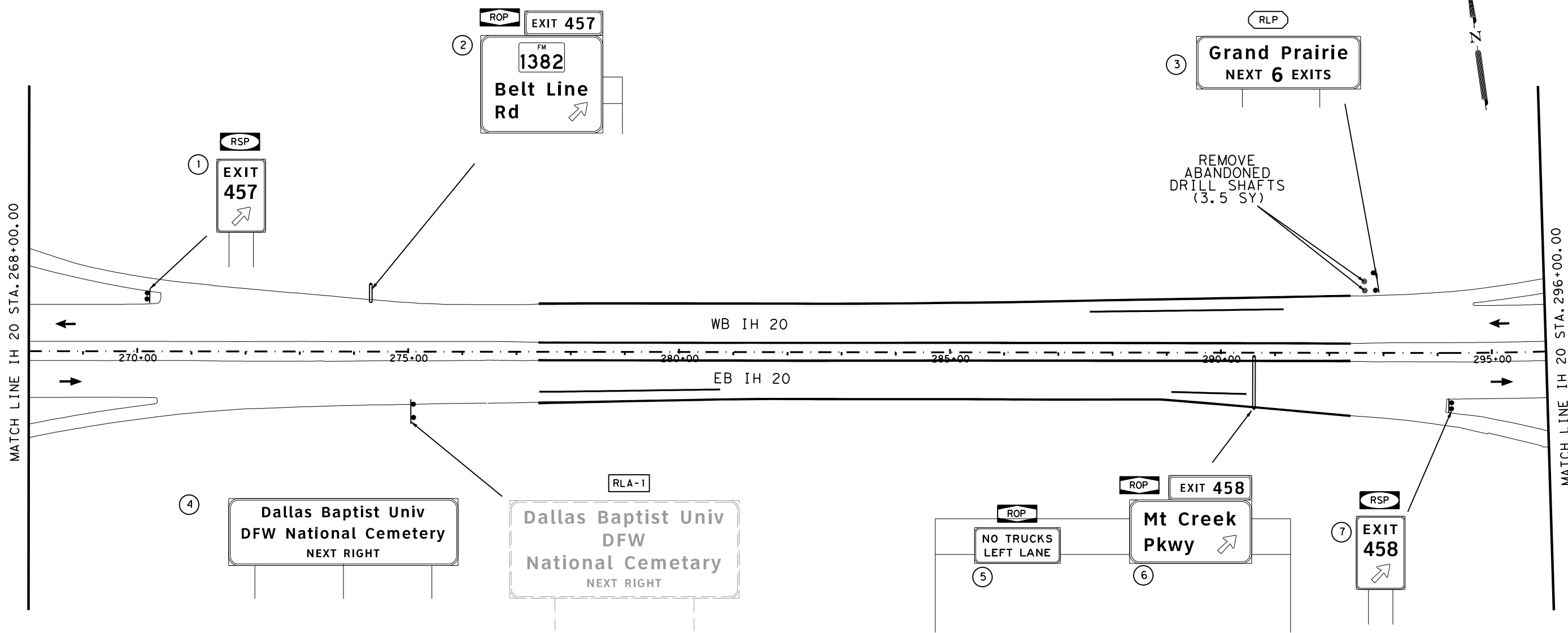

SIGNING LEGEND

- (E) EXISTING SIGN TO REMAIN
 - (3) SIGN TO BE INSTALLED
 - RSA REMOVE SMALL SIGN ASSEMBLY
 - RLA-1 REMOVE LARGE GROUND ASSEMBLY
 - RSP REPLACE SMALL SIGN PANEL
 - RLP REPLACE LARGE SIGN PANEL
 - ROP REPLACE OVERHEAD PANEL
 - ROS-1 REMOVE OVERHEAD STRUCTURE
-
- * REMOVAL ITEMS THIS SHEET
 - (EA) SMALL SIGNS ASSEMBLY
 - (EA) OVERHEAD SIGNS
 - 1 (EA) LARGE SIGNS ASSEMBLY
 - (EA) WALKWAY
 - * Removal Quantities are Approximate and Contractor Will be Paid For Actual Work Performed

INSTALL PROPOSED SIGNS
1 FT TO 2 FT BEHIND EXISTING
SIGN LOCATION,
UNLESS OTHERWISE NOTED.



Brenda L. Sanchez, P.E. 03/20/23
Signature of Registrant & Date

Texas Department of Transportation
© 2023

**SIGNING LAYOUT
IH 20**

SCALE: 1"=200' SHEET 7 OF 121

DESIGN/CK BLS	FED. RD. DIV. NO. 6	STATE PROJECT NO. (SEE TITLE SHEET)		HIGHWAY NO. IH 20
CHECK BLS	STATE	DISTRICT	COUNTY	SHEET NO.
CHECK MA	TEXAS	DAL	VARIOUS	111
CHECK BA	CONTROL	SECTION	JOB	
	0095	14	033, ETC	

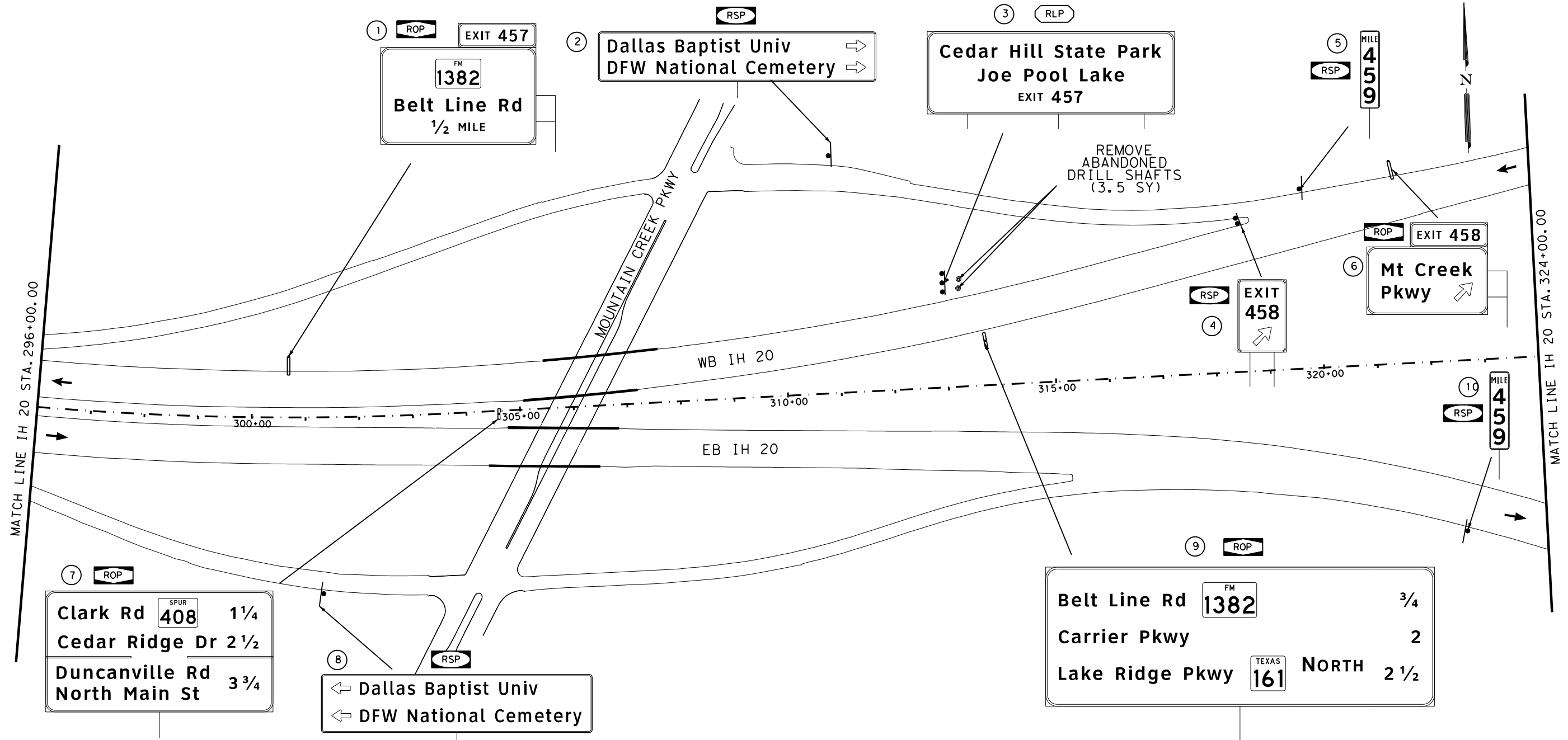

SIGNING LEGEND

- (E) EXISTING SIGN TO REMAIN
 - (3) SIGN TO BE INSTALLED
 - RSA REMOVE SMALL SIGN ASSEMBLY
 - RLA-1 REMOVE LARGE GROUND ASSEMBLY
 - RSP REPLACE SMALL SIGN PANEL
 - RLP REPLACE LARGE SIGN PANEL
 - ROP REPLACE OVERHEAD PANEL
 - ROS-1 REMOVE OVERHEAD STRUCTURE
-
- * REMOVAL ITEMS THIS SHEET
 - (EA) SMALL SIGNS ASSEMBLY
 - (EA) OVERHEAD SIGNS
 - (EA) LARGE SIGNS ASSEMBLY
 - (EA) WALKWAY
-
- * Removal Quantities are Approximate and Contractor Will be Paid For Actual Work Performed

INSTALL PROPOSED SIGNS
1 FT TO 2 FT BEHIND EXISTING
SIGN LOCATION,
UNLESS OTHERWISE NOTED.

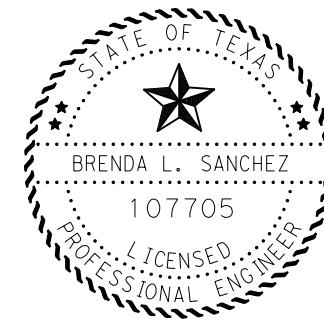

Brenda L. Sanchez, P.E. 03/20/23
Signature of Registrar & Date



**SIGNING LAYOUT
IH 20**

SCALE: 1"=200' SHEET 8 OF 121

DESIGN/CK BLS	FED. RD. DIV. NO. 6	STATE PROJECT NO. (SEE TITLE SHEET)		HIGHWAY NO. IH 20
CHECK BLS	STATE	DISTRICT DAL	COUNTY VARIOUS	SHEET NO. 112
CHECK MA	TEXAS	SECTION 0095	JOB 14	112
CHECK BA	CONTROL	SECTION 033, ETC	JOB	

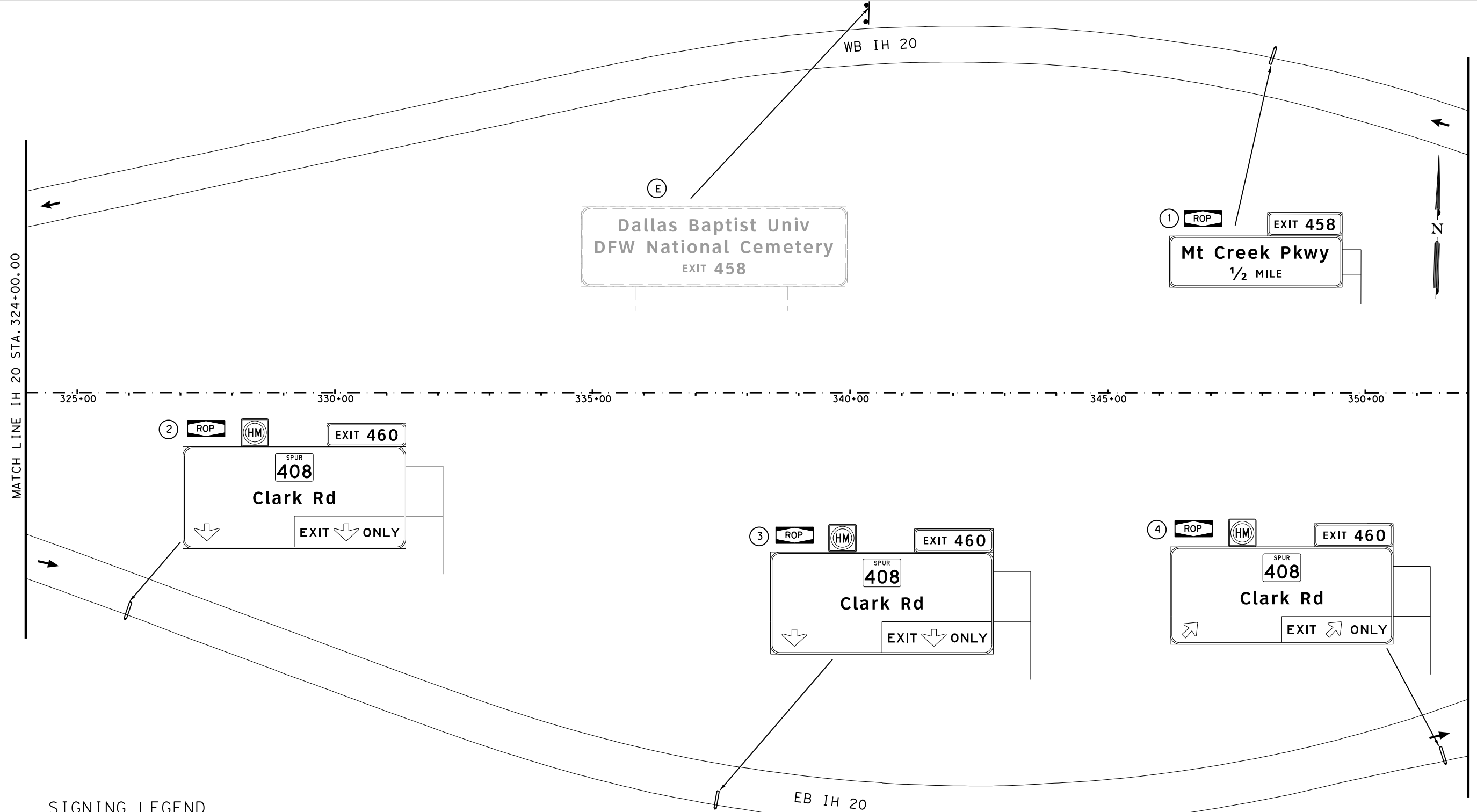

SIGNING LEGEND

- (E) EXISTING SIGN TO REMAIN
 - (3) SIGN TO BE INSTALLED
 - RSA REMOVE SMALL SIGN ASSEMBLY
 - RLA-1 REMOVE LARGE GROUND ASSEMBLY
 - RSP REPLACE SMALL SIGN PANEL
 - RLP REPLACE LARGE SIGN PANEL
 - ROP REPLACE OVERHEAD PANEL
 - ROS-1 REMOVE OVERHEAD STRUCTURE
-
- * REMOVAL ITEMS THIS SHEET
 - (EA) SMALL SIGNS ASSEMBLY
 - (EA) OVERHEAD SIGNS
 - (EA) LARGE SIGNS ASSEMBLY
 - (EA) WALKWAY
-
- * Removal Quantities are Approximate and Contractor Will be Paid For Actual Work Performed

INSTALL PROPOSED SIGNS
1 FT TO 2 FT BEHIND EXISTING
SIGN LOCATION,
UNLESS OTHERWISE NOTED.



Brenda L Sanchez, P.E. 03/20/23
Signature of Registrar & Date

Texas Department of Transportation
© 2023

**SIGNING LAYOUT
IH 20**

SCALE: 1"=200' SHEET 9 OF 121

DESIGN/CK BLS	FED. RD. DIV. NO. 6	STATE PROJECT NO. (SEE TITLE SHEET)		HIGHWAY NO. IH 20
CHECK BLS	STATE	DISTRICT DAL	COUNTY VARIOUS	SHEET NO. 113
CHECK MA	TEXAS	SECTION 14	JOB 033, ETC	
CHECK BA	CONTROL 0095			

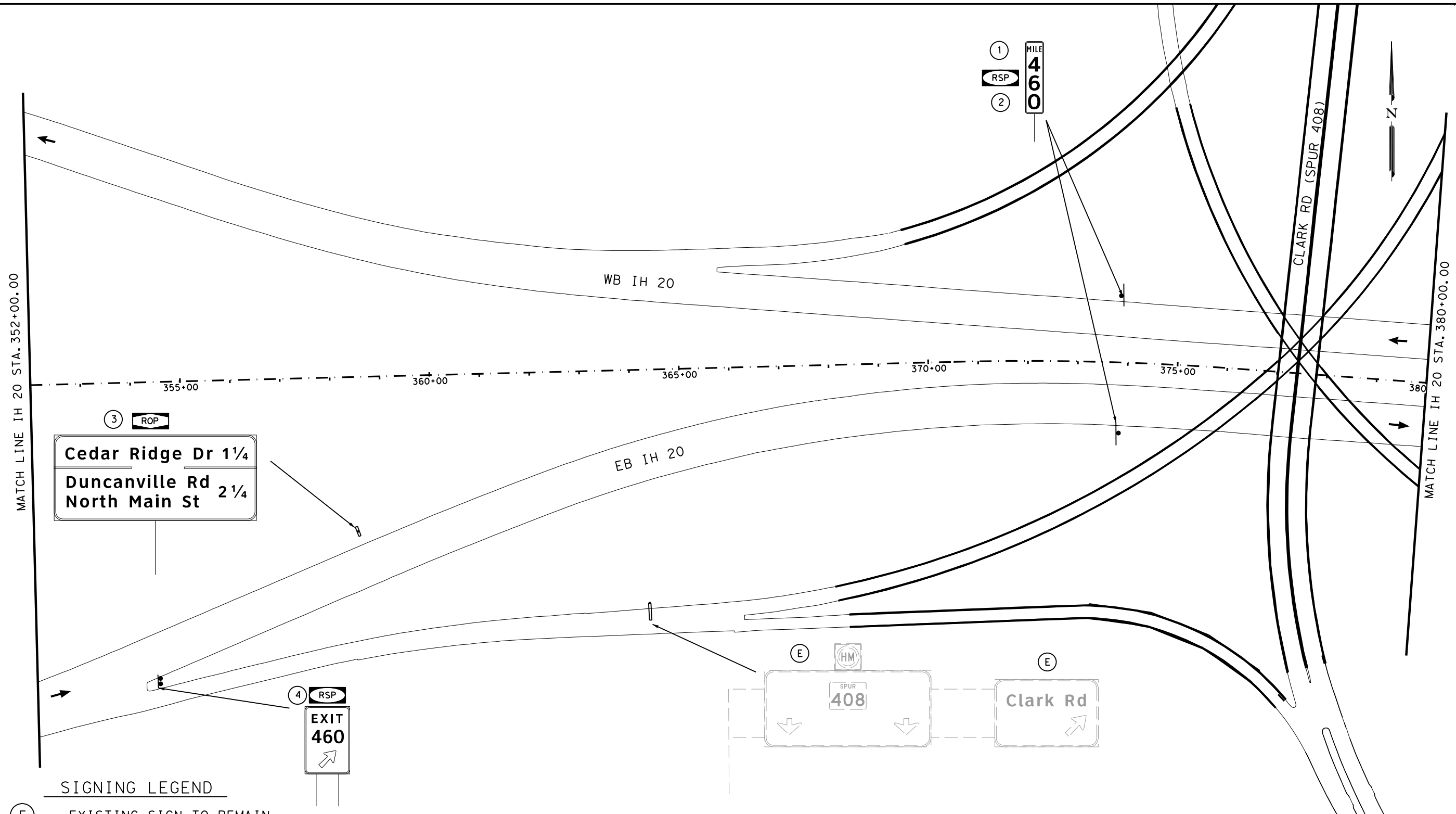

SIGNING LEGEND

- (E) EXISTING SIGN TO REMAIN
 - (3) SIGN TO BE INSTALLED
 - RSA REMOVE SMALL SIGN ASSEMBLY
 - RLA-1 REMOVE LARGE GROUND ASSEMBLY
 - RSP REPLACE SMALL SIGN PANEL
 - RLP REPLACE LARGE SIGN PANEL
 - ROP REPLACE OVERHEAD PANEL
 - ROS-1 REMOVE OVERHEAD STRUCTURE
-
- * REMOVAL ITEMS THIS SHEET
 - (EA) SMALL SIGNS ASSEMBLY
 - (EA) OVERHEAD SIGNS
 - (EA) LARGE SIGNS ASSEMBLY
 - (EA) WALKWAY
-
- * Removal Quantities are Approximate and Contractor Will be Paid For Actual Work Performed

INSTALL PROPOSED SIGNS
1 FT TO 2 FT BEHIND EXISTING
SIGN LOCATION,
UNLESS OTHERWISE NOTED.



Brenda L. Sanchez, P.E. 03/20/23
Signature of Registrar & Date



**SIGNING LAYOUT
IH 20**

SCALE: 1"=200' SHEET 10 OF 121

DESIGN/CK BLS	FED. RD. DIV. NO. 6	STATE PROJECT NO. (SEE TITLE SHEET)		HIGHWAY NO. IH 20
CHECK BLS	STATE	DISTRICT DAL	COUNTY VARIOUS	SHEET NO. 114
CHECK MA	CONTROL	SECTION	JOB	
CHECK BA	0095	14	033, ETC	

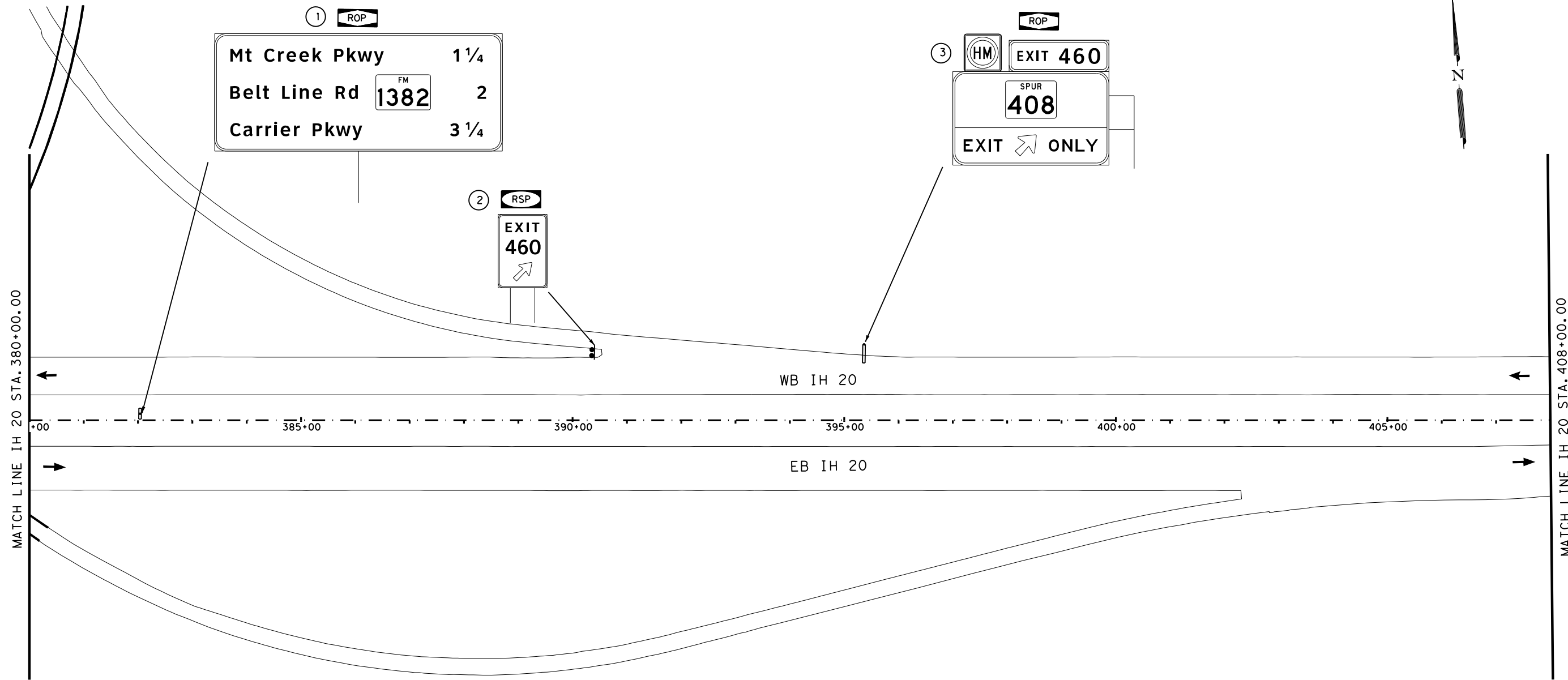

SIGNING LEGEND

- (E) EXISTING SIGN TO REMAIN
- (3) SIGN TO BE INSTALLED
- RSA REMOVE SMALL SIGN ASSEMBLY
- RLA-1 REMOVE LARGE GROUND ASSEMBLY
- RSP REPLACE SMALL SIGN PANEL
- RLP REPLACE LARGE SIGN PANEL
- ROP REPLACE OVERHEAD PANEL
- ROS-1 REMOVE OVERHEAD STRUCTURE

- * REMOVAL ITEMS THIS SHEET
- (EA) SMALL SIGNS ASSEMBLY
 - (EA) OVERHEAD SIGNS
 - (EA) LARGE SIGNS ASSEMBLY
 - (EA) WALKWAY
- * Removal Quantities are Approximate and Contractor Will be Paid For Actual Work Performed

INSTALL PROPOSED SIGNS
1 FT TO 2 FT BEHIND EXISTING
SIGN LOCATION,
UNLESS OTHERWISE NOTED.

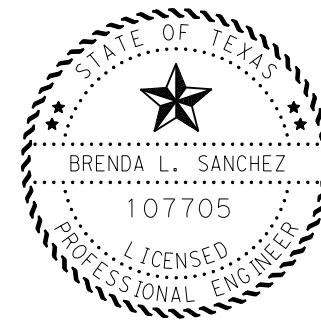

Brenda L Sanchez, P.E. 03/20/23
Signature of Registrant & Date

Texas Department of Transportation
© 2023

**SIGNING LAYOUT
IH 20**

SCALE: 1"=200' SHEET 11 OF 121

DESIGN/CK BLS	FED. RD. DIV. NO. 6	STATE PROJECT NO. (SEE TITLE SHEET)		HIGHWAY NO. IH 20
CHECK BLS	STATE	DISTRICT	COUNTY	SHEET NO.
CHECK MA	TEXAS	DAL	VARIOUS	115
CHECK BA	CONTROL	SECTION	JOB	
	0095	14	033, ETC	

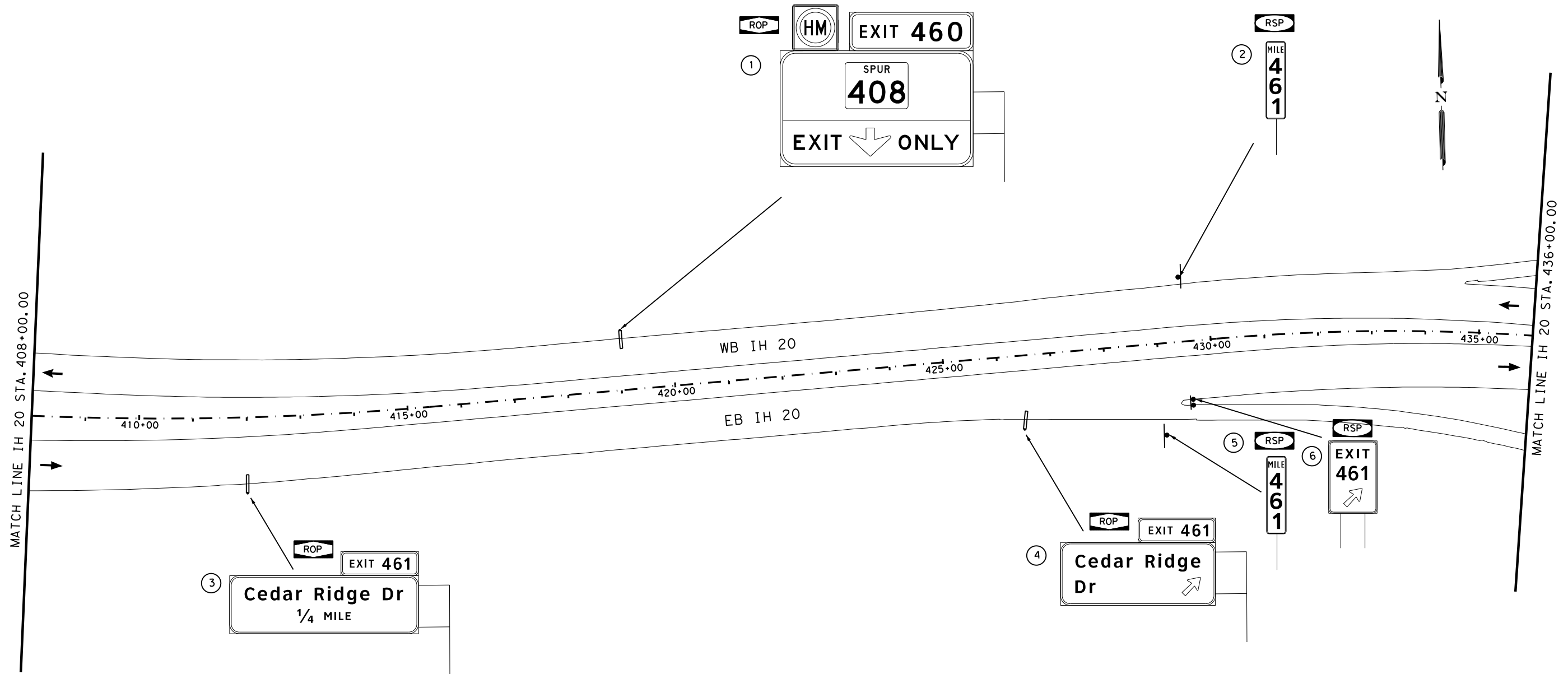

SIGNING LEGEND

- (E) EXISTING SIGN TO REMAIN
 - (3) SIGN TO BE INSTALLED
 - RSA REMOVE SMALL SIGN ASSEMBLY
 - RLA-1 REMOVE LARGE GROUND ASSEMBLY
 - RSP REPLACE SMALL SIGN PANEL
 - RLP REPLACE LARGE SIGN PANEL
 - ROP REPLACE OVERHEAD PANEL
 - ROS-1 REMOVE OVERHEAD STRUCTURE
-
- * REMOVAL ITEMS THIS SHEET
 - (EA) SMALL SIGNS ASSEMBLY
 - (EA) OVERHEAD SIGNS
 - (EA) LARGE SIGNS ASSEMBLY
 - (EA) WALKWAY
-
- * Removal Quantities are Approximate and Contractor Will be Paid For Actual Work Performed

INSTALL PROPOSED SIGNS
1 FT TO 2 FT BEHIND EXISTING
SIGN LOCATION,
UNLESS OTHERWISE NOTED.

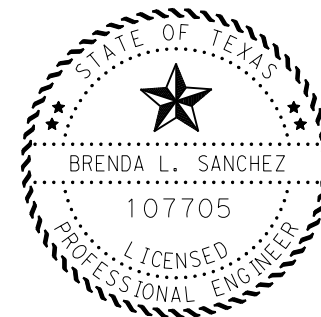

Brenda L Sanchez, P.E. 03/20/23
Signature of Registrar & Date

Texas Department of Transportation
© 2023

**SIGNING LAYOUT
IH 20**

SCALE: 1"=200' SHEET 12 OF 121

DESIGN/CK BLS	FED. RD. DIV. NO. 6	STATE PROJECT NO. (SEE TITLE SHEET)		HIGHWAY NO. IH 20
CHECK BLS	STATE	DISTRICT DAL	COUNTY VARIOUS	SHEET NO. 116
CHECK MA	CONTROL	SECTION	JOB	
CHECK BA	0095	14	033, ETC	

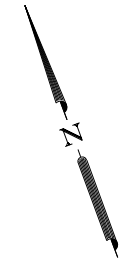
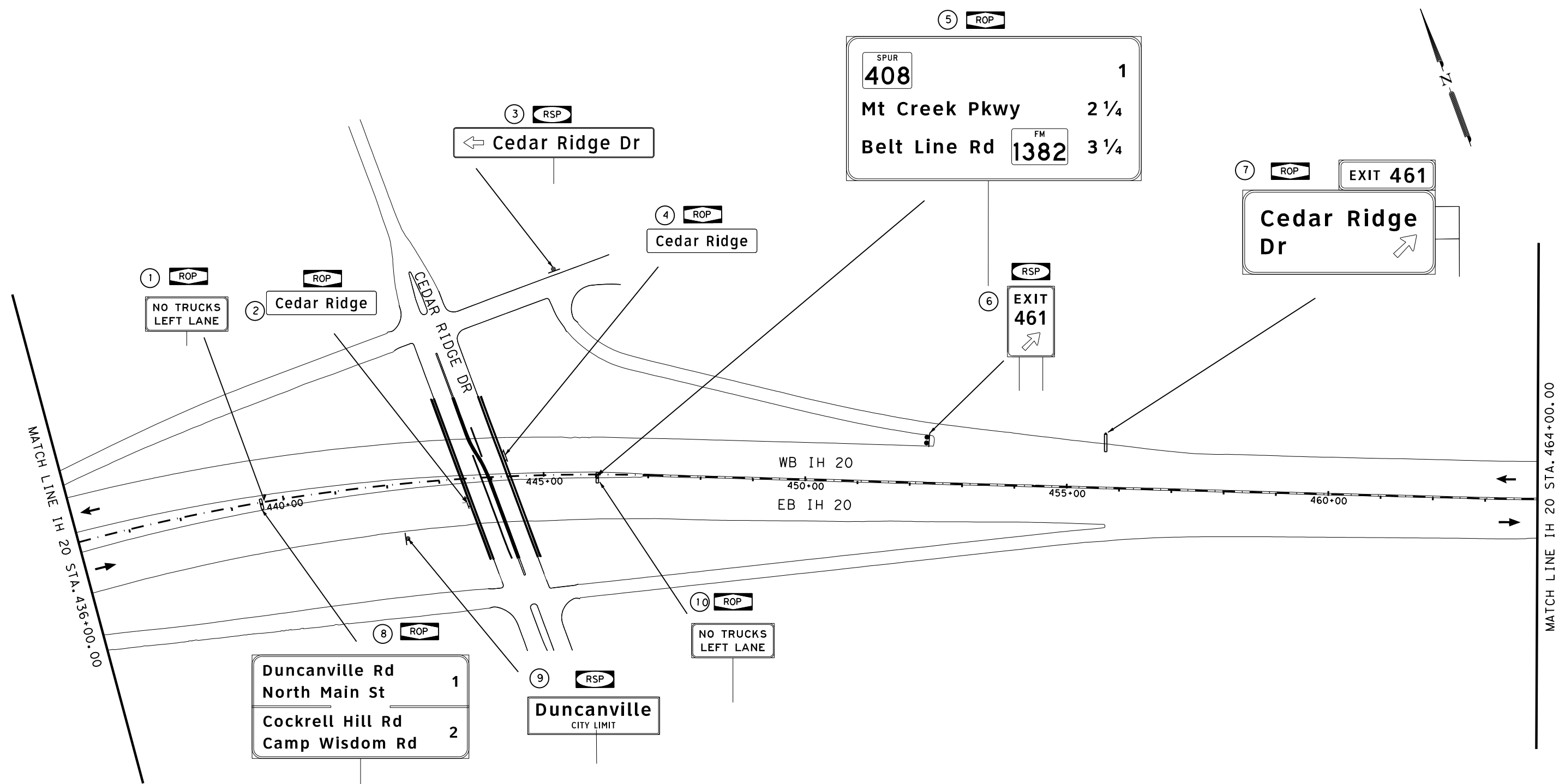

SIGNING LEGEND

- (E) EXISTING SIGN TO REMAIN
 - (3) SIGN TO BE INSTALLED
 - RSA REMOVE SMALL SIGN ASSEMBLY
 - RLA-1 REMOVE LARGE GROUND ASSEMBLY
 - RSP REPLACE SMALL SIGN PANEL
 - RLP REPLACE LARGE SIGN PANEL
 - ROP REPLACE OVERHEAD PANEL
 - ROS-1 REMOVE OVERHEAD STRUCTURE
-
- * REMOVAL ITEMS THIS SHEET
 - (EA) SMALL SIGNS ASSEMBLY
 - (EA) OVERHEAD SIGNS
 - (EA) LARGE SIGNS ASSEMBLY
 - (EA) WALKWAY
 - * Removal Quantities are Approximate and Contractor Will be Paid For Actual Work Performed

INSTALL PROPOSED SIGNS
1 FT TO 2 FT BEHIND EXISTING
SIGN LOCATION,
UNLESS OTHERWISE NOTED.

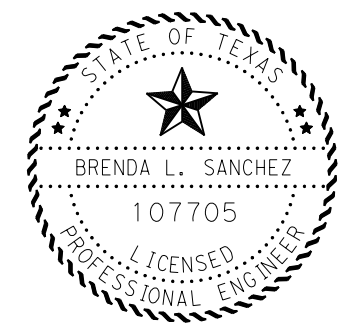

Brenda L. Sanchez, P.E. 03/20/23
Signature of Registrar & Date



**SIGNING LAYOUT
IH 20**

SCALE: 1"=200' SHEET 13 OF 121

DESIGN/CK BLS	FED. RD. DIV. NO. 6	STATE PROJECT NO. (SEE TITLE SHEET)		HIGHWAY NO. IH 20
CHECK BLS	STATE	DISTRICT	COUNTY	SHEET NO.
CHECK MA	TEXAS	DAL	VARIOUS	117
CHECK BA	CONTROL	SECTION	JOB	
	0095	14	033, ETC	

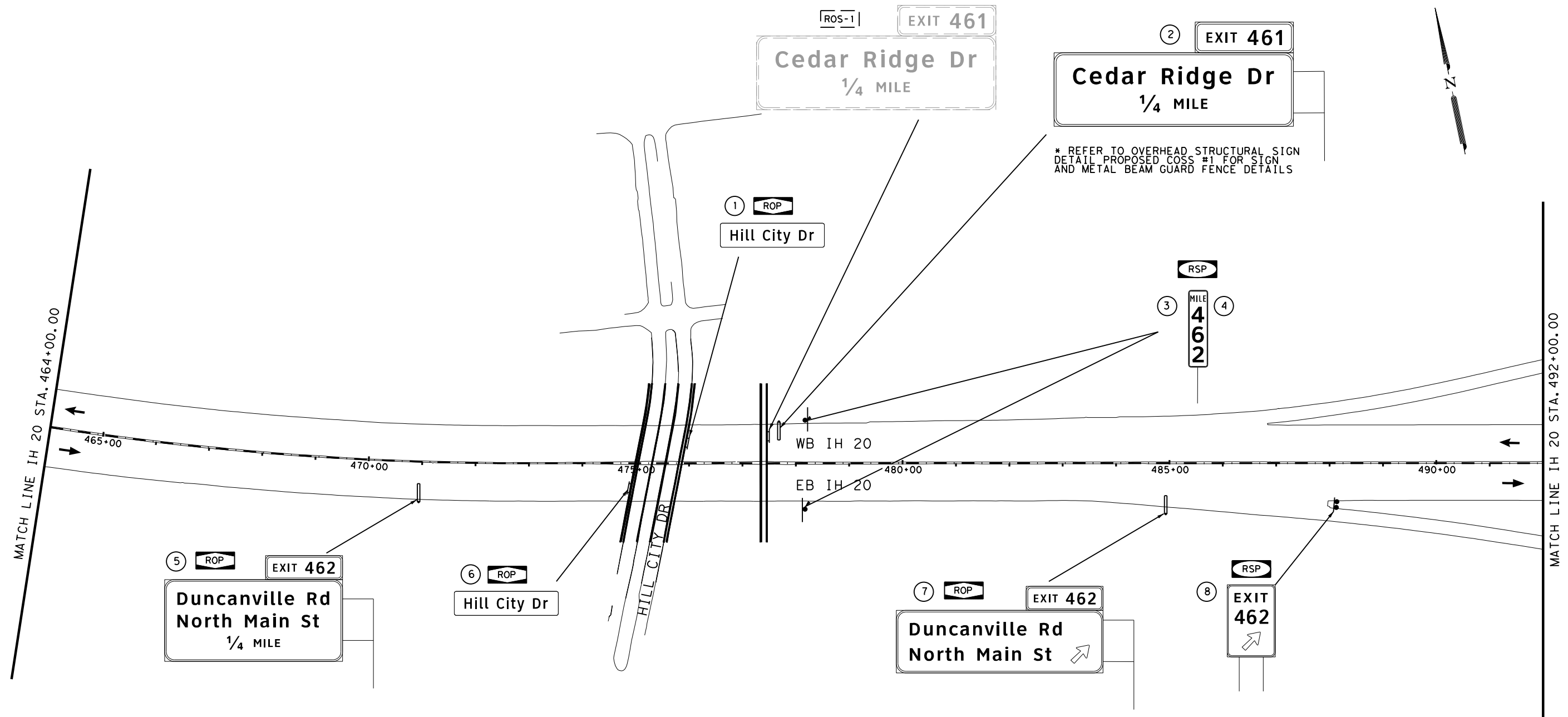

* REFER TO OVERHEAD STRUCTURAL SIGN
DETAIL PROPOSED COSS #1 FOR SIGN
AND METAL BEAM GUARD FENCE DETAILS

SIGNING LEGEND

- (E) EXISTING SIGN TO REMAIN
 - (3) SIGN TO BE INSTALLED
 - RSA REMOVE SMALL SIGN ASSEMBLY
 - RLA-1 REMOVE LARGE GROUND ASSEMBLY
 - RSP REPLACE SMALL SIGN PANEL
 - RLP REPLACE LARGE SIGN PANEL
 - ROP REPLACE OVERHEAD PANEL
 - ROS-1 REMOVE OVERHEAD STRUCTURE
-
- * REMOVAL ITEMS THIS SHEET
 - (EA) SMALL SIGNS ASSEMBLY
 - (EA) OVERHEAD SIGNS
 - (EA) LARGE SIGNS ASSEMBLY
 - (EA) WALKWAY
 - * Removal Quantities are Approximate and Contractor Will be Paid For Actual Work Performed

INSTALL PROPOSED SIGNS
1 FT TO 2 FT BEHIND EXISTING
SIGN LOCATION,
UNLESS OTHERWISE NOTED.

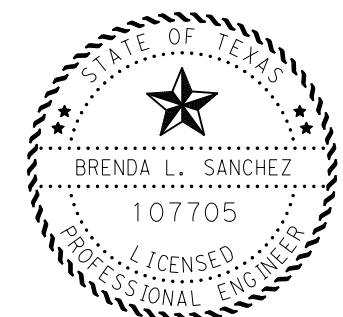

Brenda L Sanchez, P.E. 03/20/23
Signature of Registrant & Date

Texas Department of Transportation
© 2023

**SIGNING LAYOUT
IH 20**

SCALE: 1"=200' SHEET 14 OF 121

DESIGN/CK BLS	FED. RD. DIV. NO. 6	STATE PROJECT NO. (SEE TITLE SHEET)		HIGHWAY NO. IH 20
CHECK BLS	STATE	DISTRICT DAL	COUNTY VARIOUS	SHEET NO. 118
CHECK MA	TEXAS	SECTION 14	JOB 033, ETC	
CHECK BA	0095			

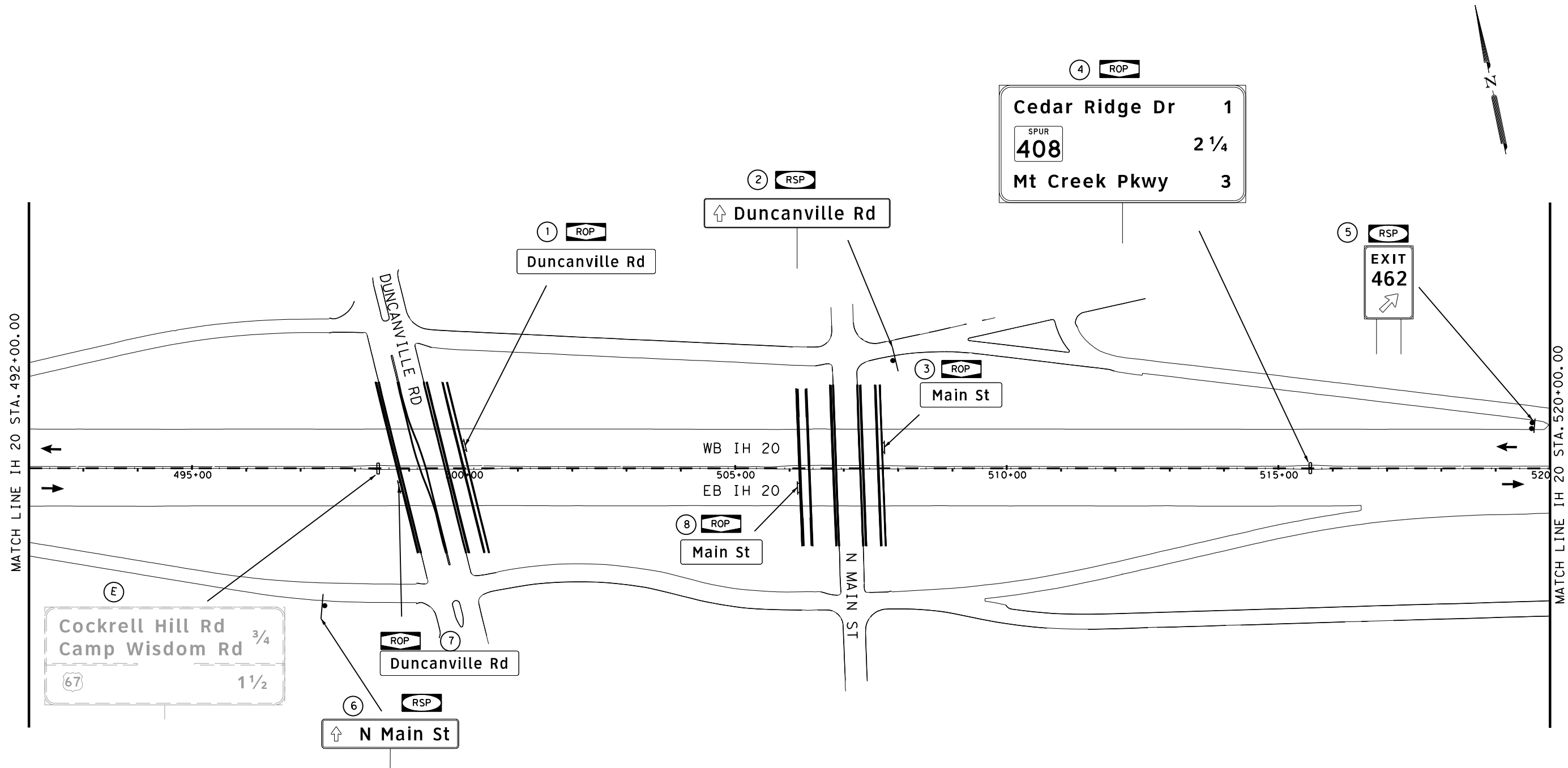

SIGNING LEGEND

- (E) EXISTING SIGN TO REMAIN
 - (3) SIGN TO BE INSTALLED
 - RSA REMOVE SMALL SIGN ASSEMBLY
 - RLA-1 REMOVE LARGE GROUND ASSEMBLY
 - RSP REPLACE SMALL SIGN PANEL
 - RLP REPLACE LARGE SIGN PANEL
 - ROP REPLACE OVERHEAD PANEL
 - ROS-1 REMOVE OVERHEAD STRUCTURE
-
- * REMOVAL ITEMS THIS SHEET
 - (EA) SMALL SIGNS ASSEMBLY
 - (EA) OVERHEAD SIGNS
 - (EA) LARGE SIGNS ASSEMBLY
 - (EA) WALKWAY
 - * Removal Quantities are Approximate and Contractor Will be Paid For Actual Work Performed

INSTALL PROPOSED SIGNS
1 FT TO 2 FT BEHIND EXISTING
SIGN LOCATION,
UNLESS OTHERWISE NOTED.

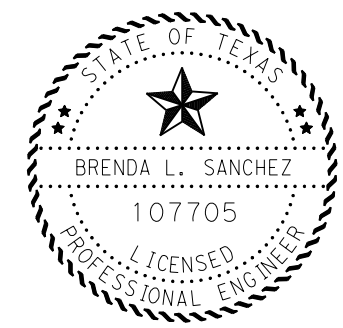

Brenda L Sanchez, P.E. 03/20/23
Signature of Registrar & Date

Texas Department of Transportation
© 2023

**SIGNING LAYOUT
IH 20**

SCALE: 1"=200' SHEET 15 OF 121

DESIGN/CK BLS	FED. RD. DIV. NO. 6	STATE PROJECT NO. (SEE TITLE SHEET)		HIGHWAY NO. IH 20
CHECK BLS	STATE	DISTRICT DAL	COUNTY VARIOUS	SHEET NO. 119
CHECK MA	TEXAS	SECTION 14	JOB 033, ETC	
CHECK BA	0095			

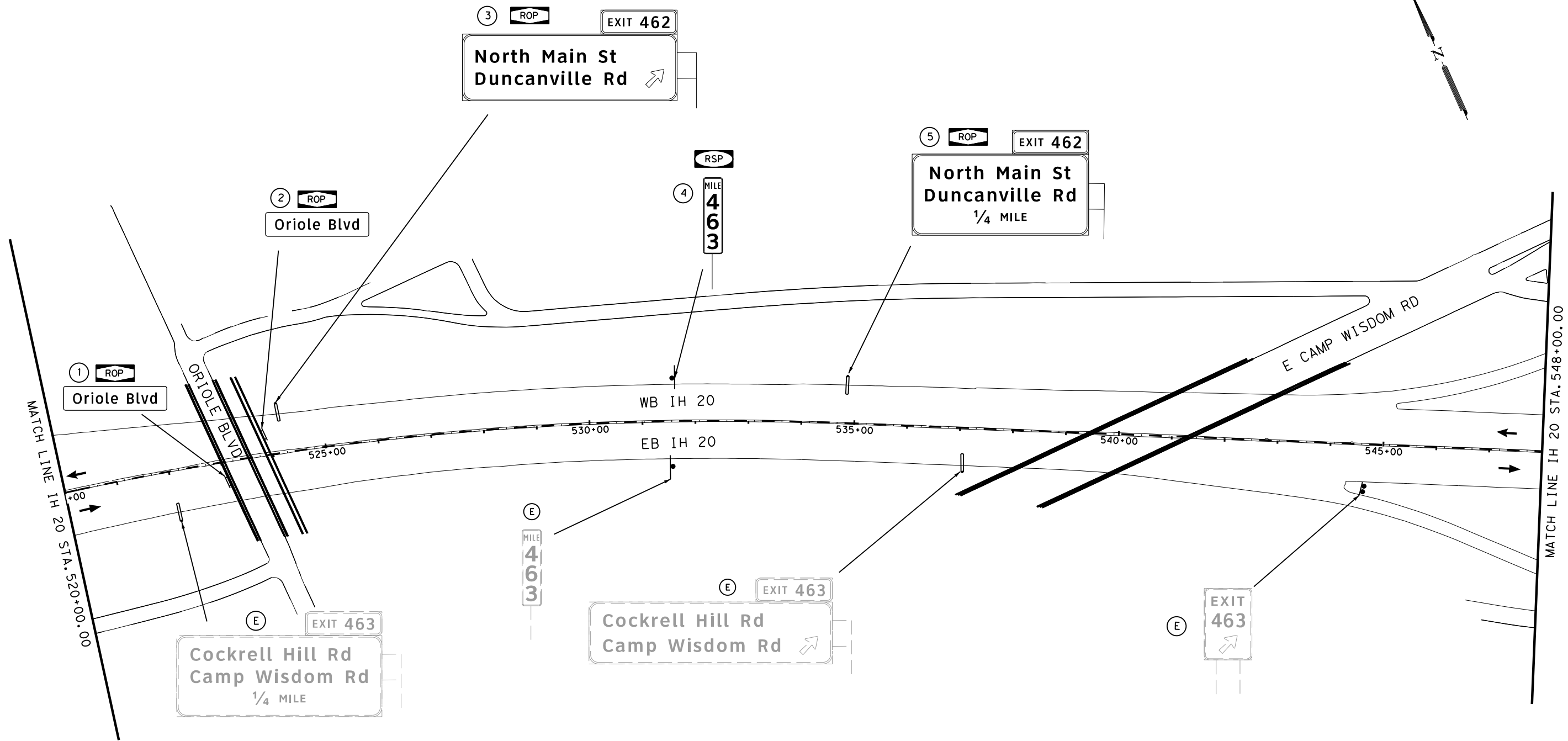
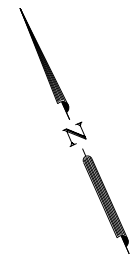

SIGNING LEGEND

- (E) EXISTING SIGN TO REMAIN
 - (3) SIGN TO BE INSTALLED
 - RSA REMOVE SMALL SIGN ASSEMBLY
 - RLA-1 REMOVE LARGE GROUND ASSEMBLY
 - RSP REPLACE SMALL SIGN PANEL
 - RLP REPLACE LARGE SIGN PANEL
 - ROP REPLACE OVERHEAD PANEL
 - ROS-1 REMOVE OVERHEAD STRUCTURE
-
- * REMOVAL ITEMS THIS SHEET
 - (EA) SMALL SIGNS ASSEMBLY
 - (EA) OVERHEAD SIGNS
 - (EA) LARGE SIGNS ASSEMBLY
 - (EA) WALKWAY
-
- * Removal Quantities are Approximate and Contractor Will be Paid For Actual Work Performed

INSTALL PROPOSED SIGNS
1 FT TO 2 FT BEHIND EXISTING
SIGN LOCATION,
UNLESS OTHERWISE NOTED.

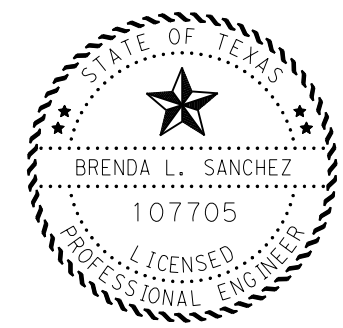

Brenda L Sanchez, P.E. 03/20/23
Signature of Registrant & Date

Texas Department of Transportation
© 2023

**SIGNING LAYOUT
IH 20**

SCALE: 1"=200' SHEET 16 OF 121

DESIGN/CK BLS	FED. RD. DIV. NO. 6	STATE PROJECT NO. (SEE TITLE SHEET)		HIGHWAY NO. IH 20
CHECK BLS	STATE	DISTRICT DAL	COUNTY VARIOUS	SHEET NO. 120
CHECK MA	CONTROL	SECTION	JOB	
CHECK BA	0095	14	033, ETC	

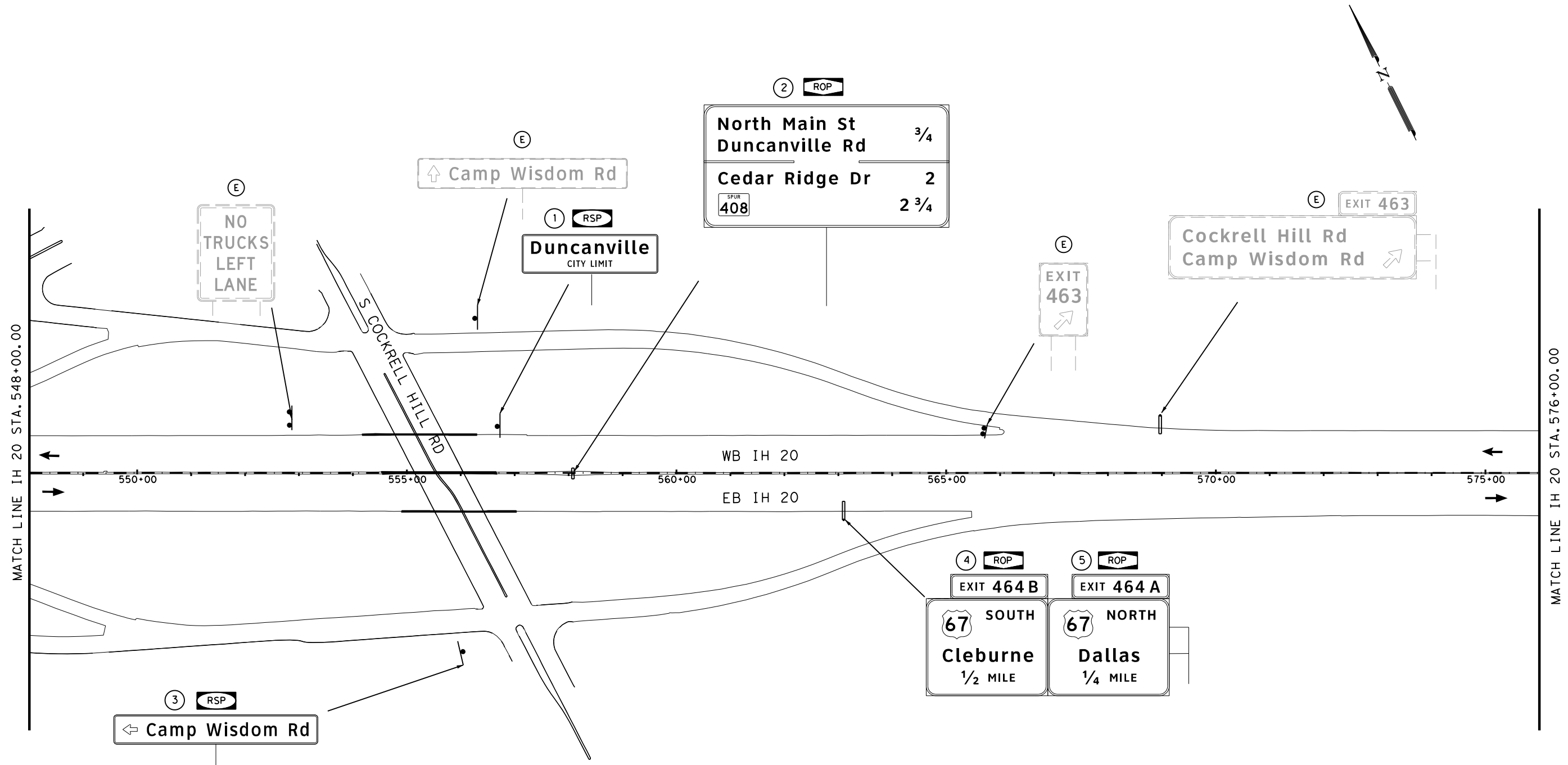

SIGNING LEGEND

- (E) EXISTING SIGN TO REMAIN
- (3) SIGN TO BE INSTALLED
- RSA REMOVE SMALL SIGN ASSEMBLY
- RLA-1 REMOVE LARGE GROUND ASSEMBLY
- RSP REPLACE SMALL SIGN PANEL
- RLP REPLACE LARGE SIGN PANEL
- ROP REPLACE OVERHEAD PANEL
- ROS-1 REMOVE OVERHEAD STRUCTURE

- * REMOVAL ITEMS THIS SHEET
- (EA) SMALL SIGNS ASSEMBLY
 - (EA) OVERHEAD SIGNS
 - (EA) LARGE SIGNS ASSEMBLY
 - (EA) WALKWAY
- * Removal Quantities are Approximate and Contractor Will be Paid For Actual Work Performed

INSTALL PROPOSED SIGNS
1 FT TO 2 FT BEHIND EXISTING
SIGN LOCATION,
UNLESS OTHERWISE NOTED.

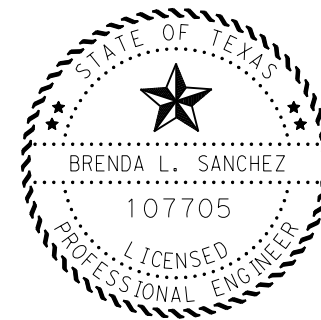

Brenda L Sanchez, P.E. 03/20/23
Signature of Registrar & Date

Texas Department of Transportation
© 2023

**SIGNING LAYOUT
IH 20**

SCALE: 1"=200' SHEET 17 OF 121

DESIGN/CK BLS	FED. RD. DIV. NO. 6	STATE PROJECT NO. (SEE TITLE SHEET)		HIGHWAY NO. IH 20
CHECK BLS	STATE	DISTRICT DAL	COUNTY VARIOUS	SHEET NO. 121
CHECK MA	TEXAS	SECTION 14	JOB 033, ETC	
CHECK BA	0095			

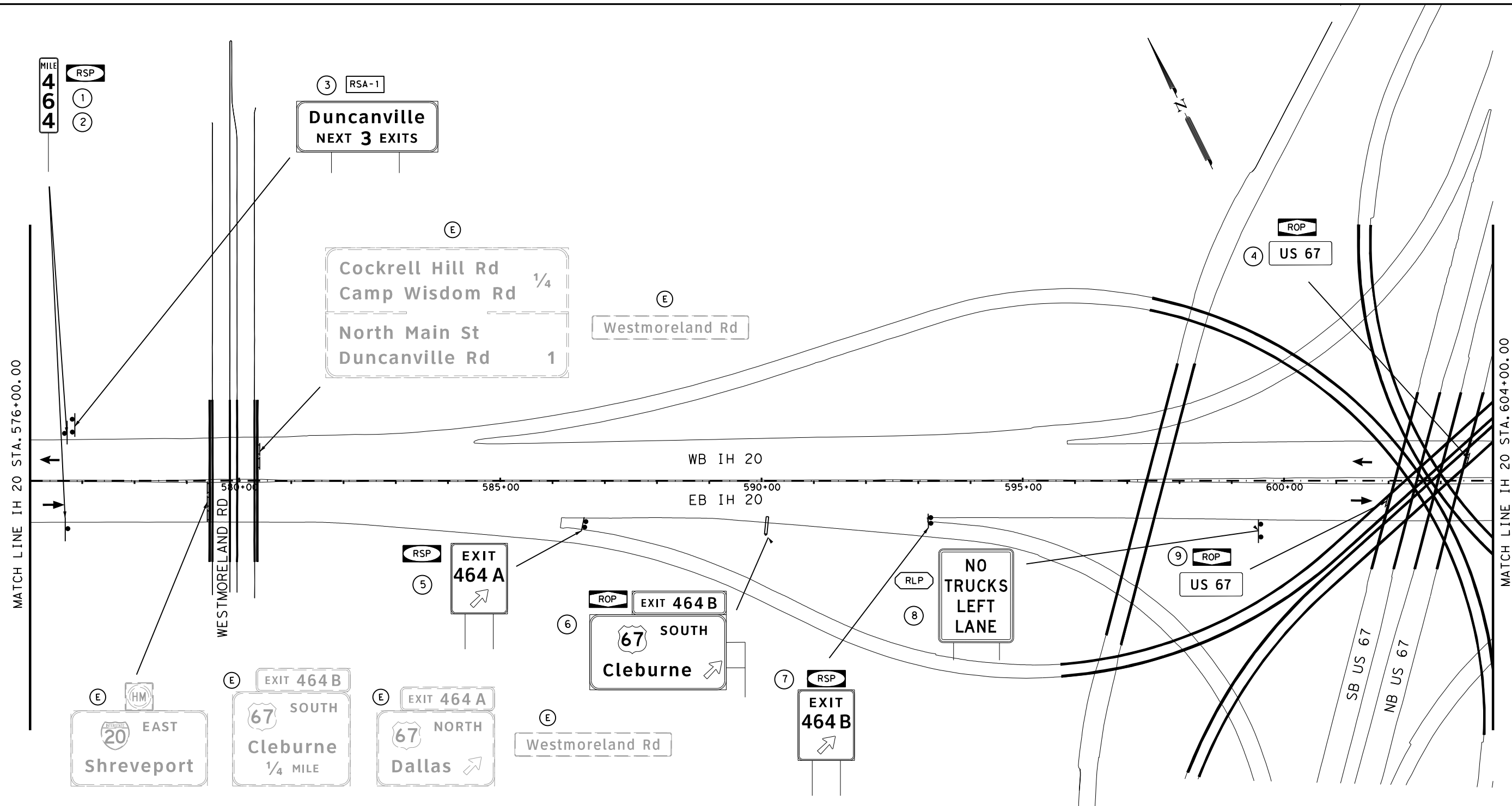

SIGNING LEGEND

- (E) EXISTING SIGN TO REMAIN
 - (3) SIGN TO BE INSTALLED
 - RSA REMOVE SMALL SIGN ASSEMBLY
 - RLA-1 REMOVE LARGE GROUND ASSEMBLY
 - RSP REPLACE SMALL SIGN PANEL
 - RLP REPLACE LARGE SIGN PANEL
 - ROP REPLACE OVERHEAD PANEL
 - ROS-1 REMOVE OVERHEAD STRUCTURE
-
- * REMOVAL ITEMS THIS SHEET
 - 1 (EA) SMALL SIGNS ASSEMBLY
 - (EA) OVERHEAD SIGNS
 - (EA) LARGE SIGNS ASSEMBLY
 - (EA) WALKWAY
-
- * Removal Quantities are Approximate and Contractor Will be Paid For Actual Work Performed

INSTALL PROPOSED SIGNS
1 FT TO 2 FT BEHIND EXISTING
SIGN LOCATION,
UNLESS OTHERWISE NOTED.

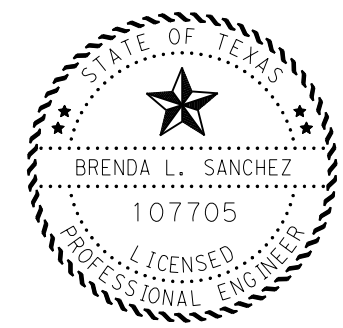

Brenda L Sanchez, P.E. 03/20/23
Signature of Registrar & Date

Texas Department of Transportation
© 2023

**SIGNING LAYOUT
IH 20**

SCALE: 1"=200' SHEET 18 OF 121

DESIGN/CK BLS	FED. RD. DIV. NO. 6	STATE PROJECT NO. (SEE TITLE SHEET)		HIGHWAY NO. IH 20
CHECK BLS	STATE	DISTRICT DAL	COUNTY VARIOUS	SHEET NO. 122
CHECK MA	CONTROL	SECTION	JOB	
CHECK BA	0095	14	033, ETC	

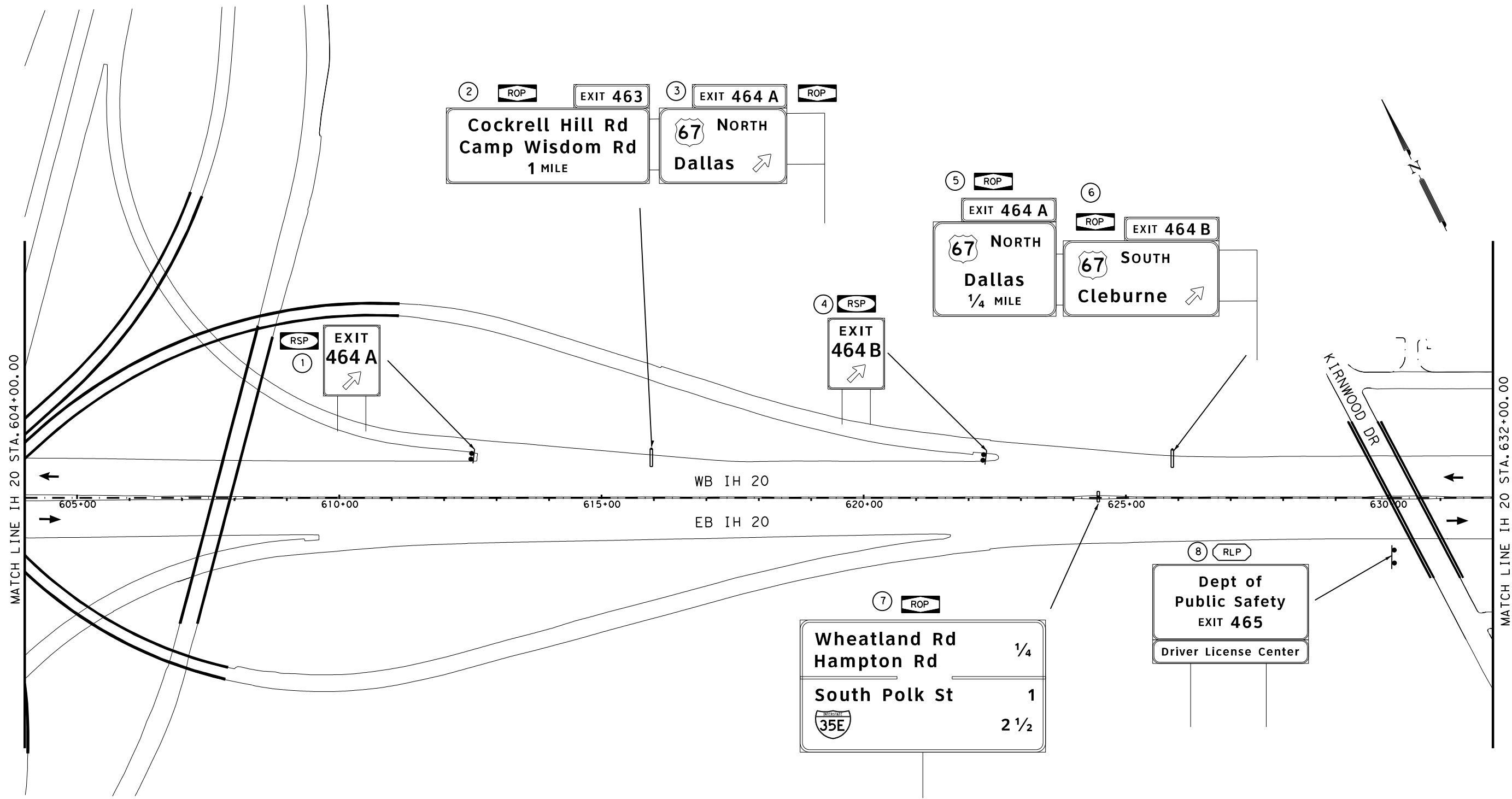

SIGNING LEGEND

- (E) EXISTING SIGN TO REMAIN
 - (3) SIGN TO BE INSTALLED
 - RSA REMOVE SMALL SIGN ASSEMBLY
 - RLA-1 REMOVE LARGE GROUND ASSEMBLY
 - RSP REPLACE SMALL SIGN PANEL
 - RLP REPLACE LARGE SIGN PANEL
 - ROP REPLACE OVERHEAD PANEL
 - ROS-1 REMOVE OVERHEAD STRUCTURE
-
- * REMOVAL ITEMS THIS SHEET
 - (EA) SMALL SIGNS ASSEMBLY
 - (EA) OVERHEAD SIGNS
 - (EA) LARGE SIGNS ASSEMBLY
 - (EA) WALKWAY
 - * Removal Quantities are Approximate and Contractor Will be Paid For Actual Work Performed

INSTALL PROPOSED SIGNS
1 FT TO 2 FT BEHIND EXISTING
SIGN LOCATION,
UNLESS OTHERWISE NOTED.

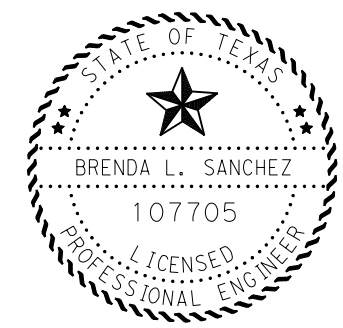

Brenda L Sanchez, P.E. 03/20/23
Signature of Registrar & Date

Texas Department of Transportation
© 2023

**SIGNING LAYOUT
IH 20**

SCALE: 1"=200' SHEET 19 OF 121

DESIGN/CK BLS	FED. RD. DIV. NO. 6	STATE PROJECT NO. (SEE TITLE SHEET)		HIGHWAY NO. IH 20
CHECK BLS	STATE	DISTRICT DAL	COUNTY VARIOUS	SHEET NO. 123
CHECK MA	TEXAS	SECTION 0095	JOB 033, ETC	
CHECK BA	CONTROL	SECTION 14	JOB 033, ETC	

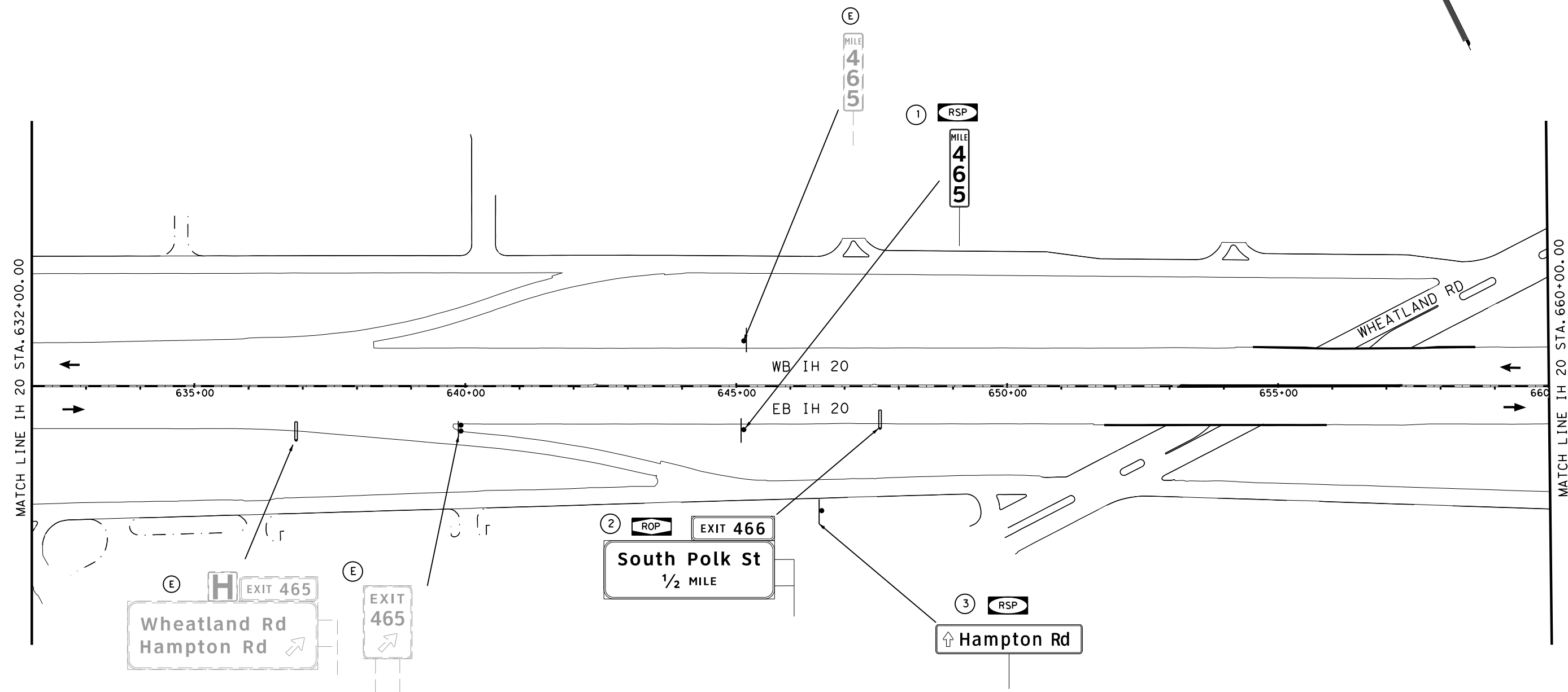

SIGNING LEGEND

- (E) EXISTING SIGN TO REMAIN
 - (3) SIGN TO BE INSTALLED
 - RSA REMOVE SMALL SIGN ASSEMBLY
 - RLA-1 REMOVE LARGE GROUND ASSEMBLY
 - RSP REPLACE SMALL SIGN PANEL
 - RLP REPLACE LARGE SIGN PANEL
 - ROP REPLACE OVERHEAD PANEL
 - ROS-1 REMOVE OVERHEAD STRUCTURE
-
- * REMOVAL ITEMS THIS SHEET
 - (EA) SMALL SIGNS ASSEMBLY
 - (EA) OVERHEAD SIGNS
 - (EA) LARGE SIGNS ASSEMBLY
 - (EA) WALKWAY
 - * Removal Quantities are Approximate and Contractor Will be Paid For Actual Work Performed

INSTALL PROPOSED SIGNS
1 FT TO 2 FT BEHIND EXISTING
SIGN LOCATION,
UNLESS OTHERWISE NOTED.

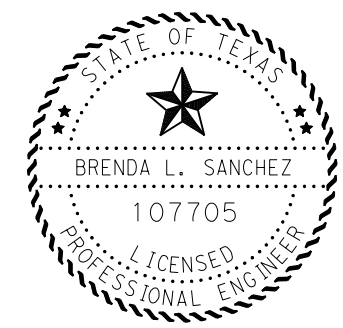

Brenda L. Sanchez, P.E. 03/20/23
Signature of Registrant & Date



**SIGNING LAYOUT
IH 20**

SCALE: 1"=200' SHEET 20 OF 121

DESIGN/CK	FED. RD. DIV. NO.	STATE PROJECT NO.		HIGHWAY NO.
BLS	6	(SEE TITLE SHEET)		IH 20
CHECK	STATE	DISTRICT	COUNTY	SHEET NO.
BLS	TEXAS	DAL	VARIOUS	124
CHECK	CONTROL	SECTION	JOB	
MA	0095	14	033, ETC	

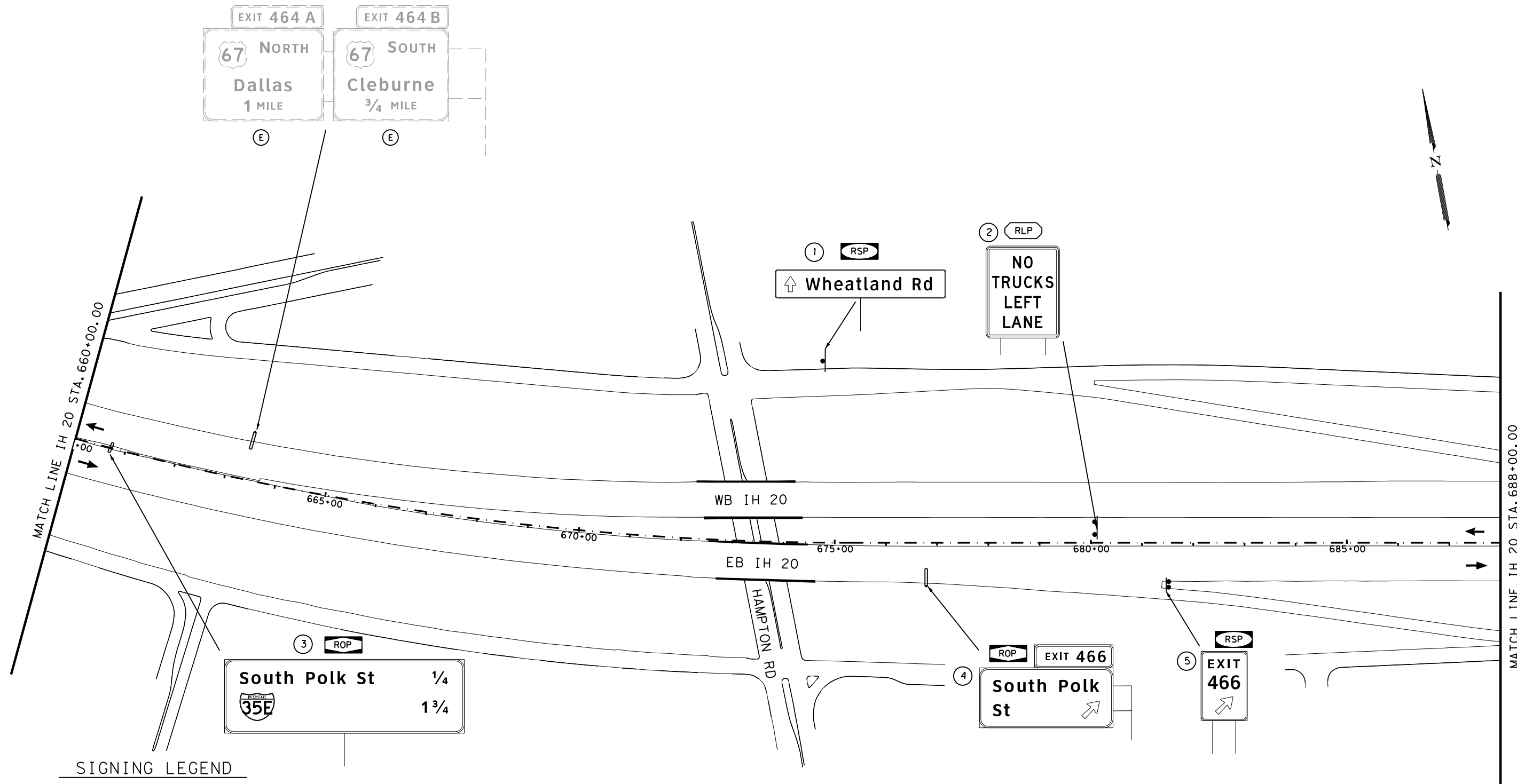

SIGNING LEGEND

- (E) EXISTING SIGN TO REMAIN
 - (3) SIGN TO BE INSTALLED
 - RSA REMOVE SMALL SIGN ASSEMBLY
 - RLA-1 REMOVE LARGE GROUND ASSEMBLY
 - RSP REPLACE SMALL SIGN PANEL
 - RLP REPLACE LARGE SIGN PANEL
 - ROP REPLACE OVERHEAD PANEL
 - ROS-1 REMOVE OVERHEAD STRUCTURE
-
- * REMOVAL ITEMS THIS SHEET
 - (EA) SMALL SIGNS ASSEMBLY
 - (EA) OVERHEAD SIGNS
 - (EA) LARGE SIGNS ASSEMBLY
 - (EA) WALKWAY
-
- * Removal Quantities are Approximate and Contractor Will be Paid For Actual Work Performed

INSTALL PROPOSED SIGNS
1 FT TO 2 FT BEHIND EXISTING
SIGN LOCATION,
UNLESS OTHERWISE NOTED.

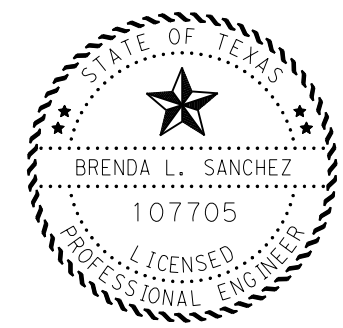

Brenda L. Sanchez, P.E. 03/20/23
Signature of Registrar & Date



**SIGNING LAYOUT
IH 20**

SCALE: 1"=200' SHEET 21 OF 121

DESIGN/CK	FED. RD. DIV. NO.	STATE PROJECT NO.		HIGHWAY NO.
BLS	6	(SEE TITLE SHEET)		IH 20
CHECK	STATE	DISTRICT	COUNTY	SHEET NO.
BLS	TEXAS	DAL	VARIOUS	125
CHECK	CONTROL	SECTION	JOB	
BA	0095	14	033, ETC	

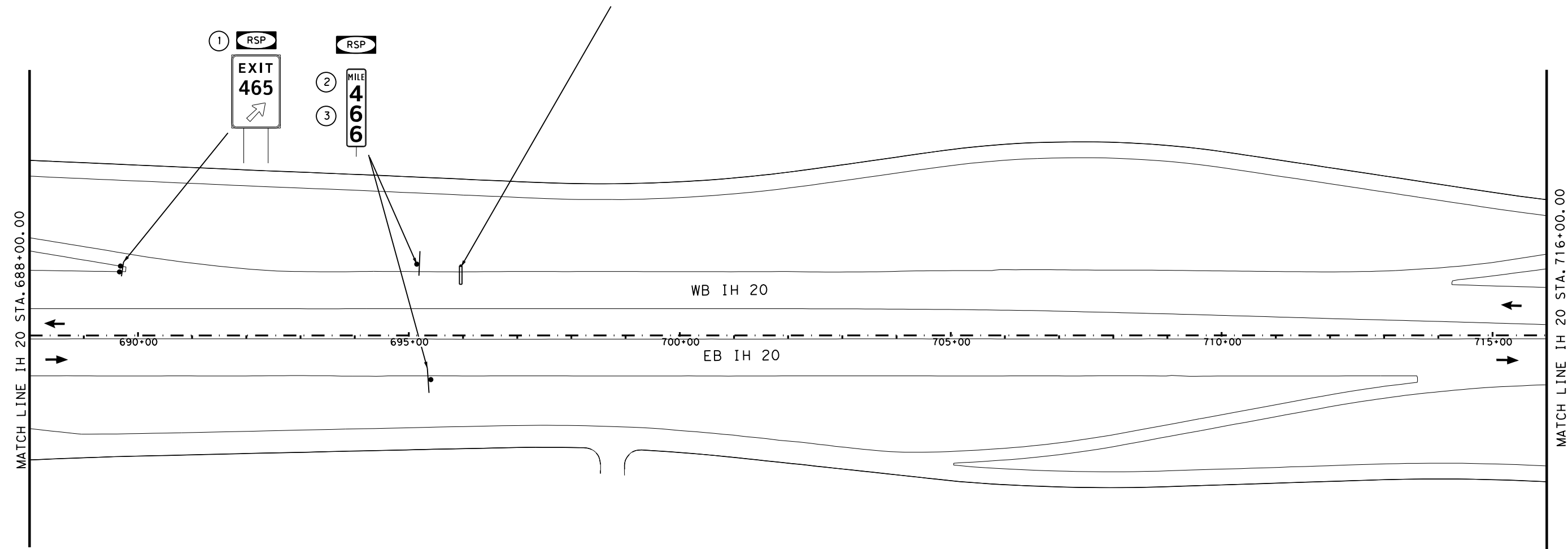
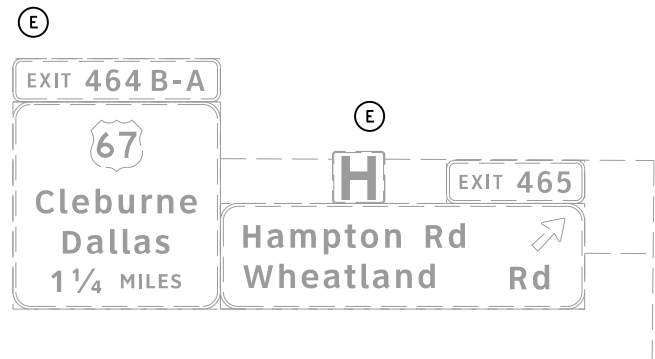

SIGNING LEGEND

- (E) EXISTING SIGN TO REMAIN
 - (3) SIGN TO BE INSTALLED
 - RSA REMOVE SMALL SIGN ASSEMBLY
 - RLA-1 REMOVE LARGE GROUND ASSEMBLY
 - RSP REPLACE SMALL SIGN PANEL
 - RLP REPLACE LARGE SIGN PANEL
 - ROP REPLACE OVERHEAD PANEL
 - ROS-1 REMOVE OVERHEAD STRUCTURE
-
- * REMOVAL ITEMS THIS SHEET
 - (EA) SMALL SIGNS ASSEMBLY
 - (EA) OVERHEAD SIGNS
 - (EA) LARGE SIGNS ASSEMBLY
 - (EA) WALKWAY
 - * Removal Quantities are Approximate and Contractor Will be Paid For Actual Work Performed

INSTALL PROPOSED SIGNS
1 FT TO 2 FT BEHIND EXISTING
SIGN LOCATION,
UNLESS OTHERWISE NOTED.



Brenda L. Sanchez, P.E. 03/20/23
Signature of Registrar & Date

Texas Department of Transportation
© 2023

**SIGNING LAYOUT
IH 20**

SCALE: 1"=200' SHEET 22 OF 121

DESIGN/CK BLS	FED. RD. DIV. NO. 6	STATE PROJECT NO. (SEE TITLE SHEET)		HIGHWAY NO. IH 20
CHECK BLS	STATE	DISTRICT	COUNTY	SHEET NO.
CHECK MA	TEXAS	DAL	VARIOUS	126
CHECK BA	CONTROL	SECTION	JOB	
	0095	14	033, ETC	

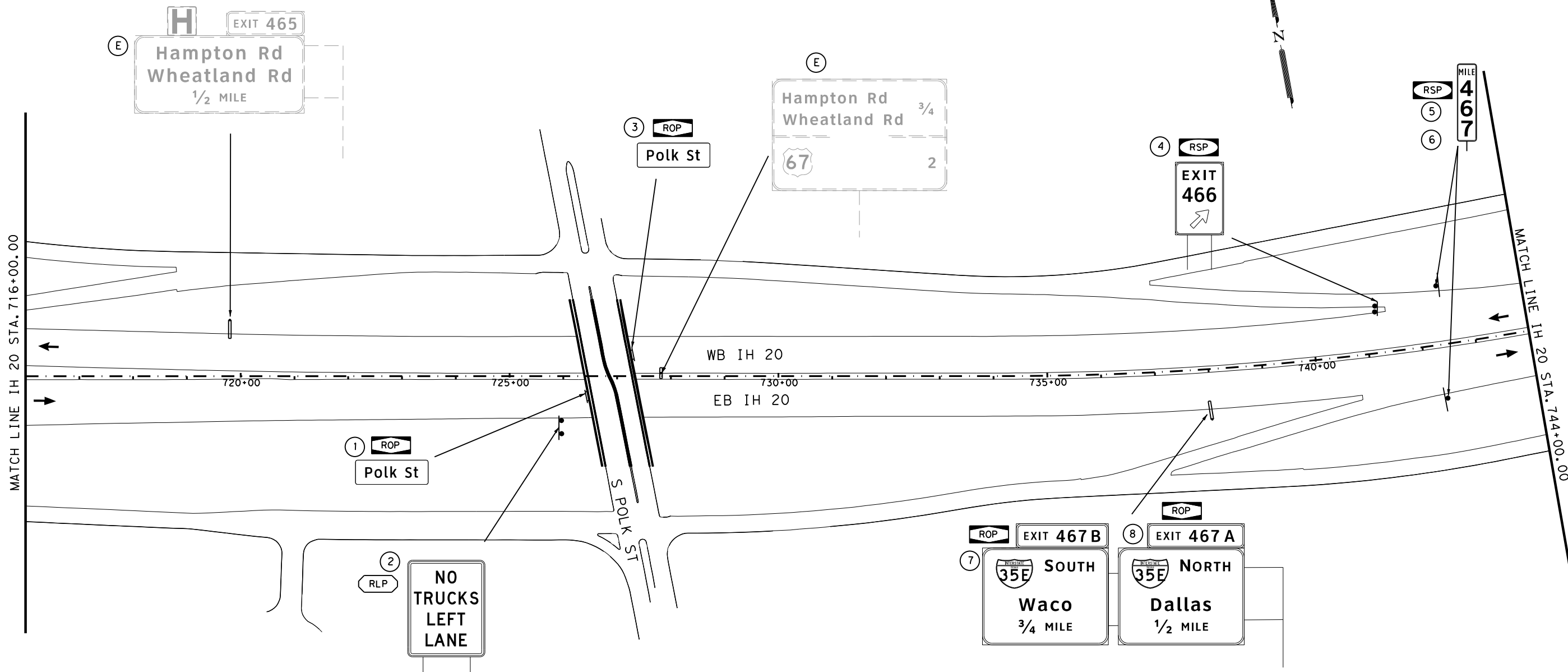

SIGNING LEGEND

- (E) EXISTING SIGN TO REMAIN
- (3) SIGN TO BE INSTALLED
- RSA REMOVE SMALL SIGN ASSEMBLY
- RLA-1 REMOVE LARGE GROUND ASSEMBLY
- RSP REPLACE SMALL SIGN PANEL
- RLP REPLACE LARGE SIGN PANEL
- ROP REPLACE OVERHEAD PANEL
- ROS-1 REMOVE OVERHEAD STRUCTURE

- * REMOVAL ITEMS THIS SHEET
- (EA) SMALL SIGNS ASSEMBLY
 - (EA) OVERHEAD SIGNS
 - (EA) LARGE SIGNS ASSEMBLY
 - (EA) WALKWAY
- * Removal Quantities are Approximate and Contractor Will be Paid For Actual Work Performed

INSTALL PROPOSED SIGNS
1 FT TO 2 FT BEHIND EXISTING
SIGN LOCATION,
UNLESS OTHERWISE NOTED.

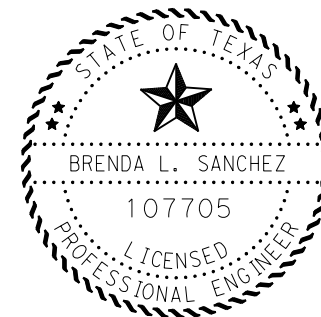

Brenda L. Sanchez, P.E. 03/20/23
Signature of Registrar & Date



**SIGNING LAYOUT
IH 20**

SCALE: 1"=200' SHEET 23 OF 121

DESIGN/CK BLS	FED. RD. DIV. NO. 6	STATE PROJECT NO. (SEE TITLE SHEET)		HIGHWAY NO. IH 20
CHECK BLS	STATE	DISTRICT DAL	COUNTY VARIOUS	SHEET NO. 127
CHECK MA	TEXAS	SECTION 14	JOB 033, ETC	
CHECK BA	0095			

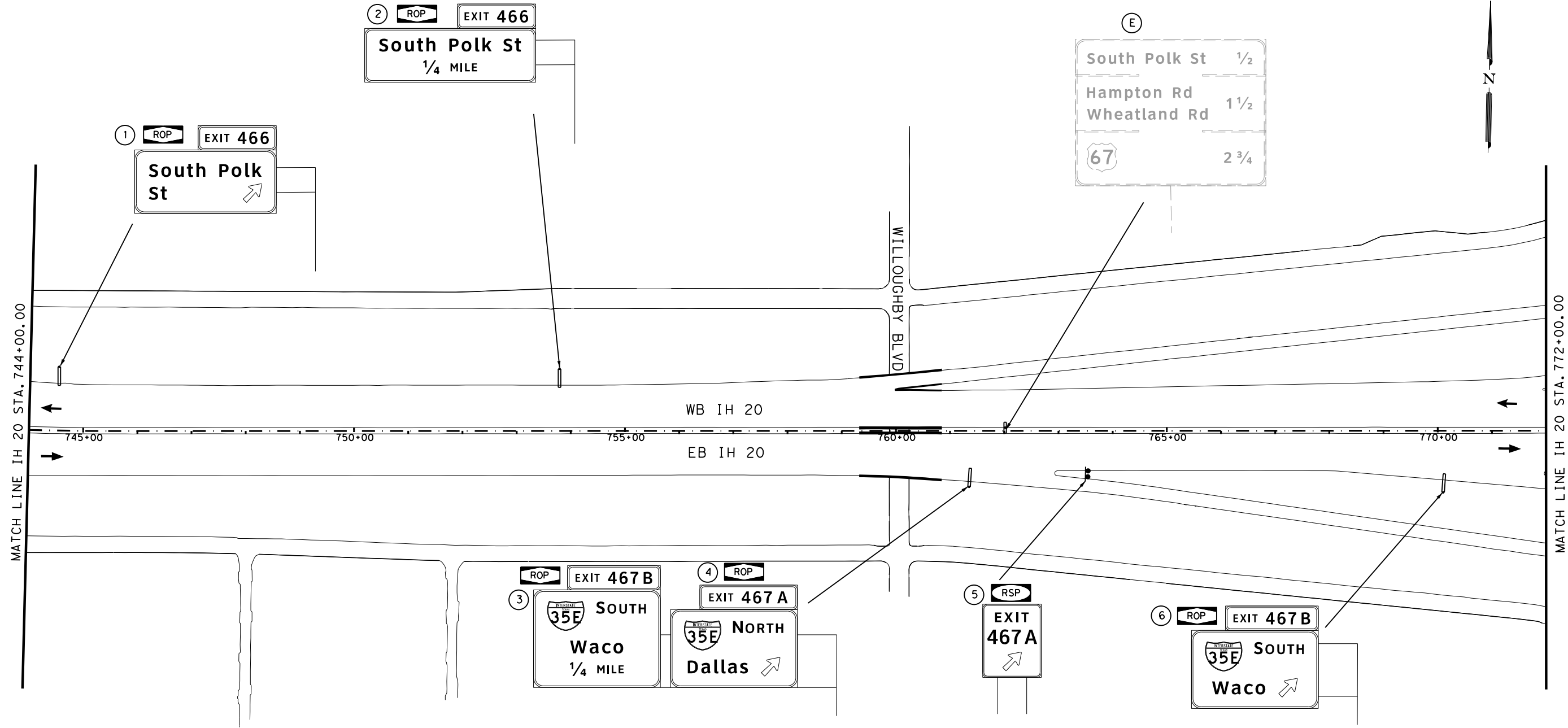

SIGNING LEGEND

- (E) EXISTING SIGN TO REMAIN
- (3) SIGN TO BE INSTALLED
- RSA REMOVE SMALL SIGN ASSEMBLY
- RLA-1 REMOVE LARGE GROUND ASSEMBLY
- RSP REPLACE SMALL SIGN PANEL
- RLP REPLACE LARGE SIGN PANEL
- ROP REPLACE OVERHEAD PANEL
- ROS-1 REMOVE OVERHEAD STRUCTURE

- * REMOVAL ITEMS THIS SHEET
- (EA) SMALL SIGNS ASSEMBLY
- (EA) OVERHEAD SIGNS
- (EA) LARGE SIGNS ASSEMBLY
- (EA) WALKWAY
- * Removal Quantities are Approximate and Contractor Will be Paid For Actual Work Performed

INSTALL PROPOSED SIGNS
1 FT TO 2 FT BEHIND EXISTING
SIGN LOCATION,
UNLESS OTHERWISE NOTED.



Brenda L Sanchez, P.E. 03/20/23
Signature of Registrant & Date



**SIGNING LAYOUT
IH 20**

SCALE: 1"=200' SHEET 24 OF 121

DESIGN/CK	FED. RD. DIV. NO.	STATE PROJECT NO.		HIGHWAY NO.
BLS	6	(SEE TITLE SHEET)		IH 20
CHECK	STATE	DISTRICT	COUNTY	SHEET NO.
BLS	TEXAS	DAL	VARIOUS	128
CHECK	CONTROL	SECTION	JOB	
BA	0095	14	033, ETC	

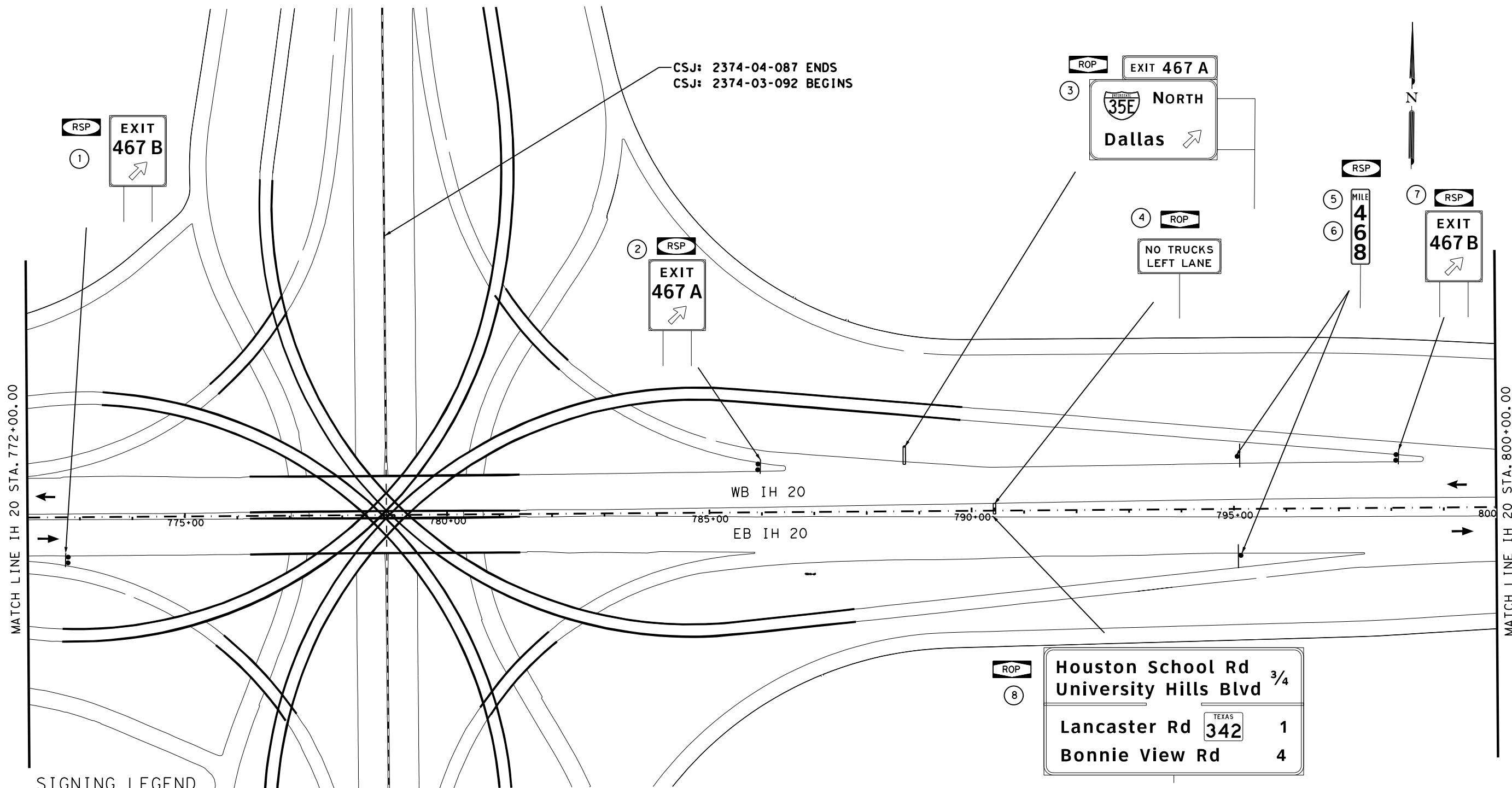

SIGNING LEGEND

- (E) EXISTING SIGN TO REMAIN
- (3) SIGN TO BE INSTALLED
- RSA REMOVE SMALL SIGN ASSEMBLY
- RLA-1 REMOVE LARGE GROUND ASSEMBLY
- RSP REPLACE SMALL SIGN PANEL
- RLP REPLACE LARGE SIGN PANEL
- ROP REPLACE OVERHEAD PANEL
- ROS-1 REMOVE OVERHEAD STRUCTURE

- * REMOVAL ITEMS THIS SHEET
- (EA) SMALL SIGNS ASSEMBLY
 - (EA) OVERHEAD SIGNS
 - (EA) LARGE SIGNS ASSEMBLY
 - (EA) WALKWAY
- * Removal Quantities are Approximate and Contractor Will be Paid For Actual Work Performed

INSTALL PROPOSED SIGNS
1 FT TO 2 FT BEHIND EXISTING
SIGN LOCATION,
UNLESS OTHERWISE NOTED.

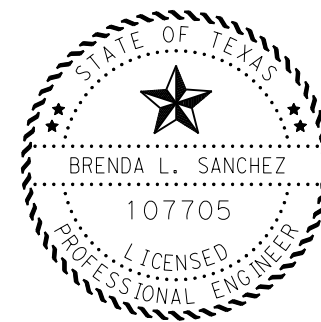

Brenda L Sanchez, P.E. 03/20/23
Signature of Registrant & Date



**SIGNING LAYOUT
IH 20**

SCALE: 1"=200' SHEET 25 OF 121

DESIGN/CK BLS	FED. RD. DIV. NO. 6	STATE PROJECT NO. (SEE TITLE SHEET)		HIGHWAY NO. IH 20
CHECK BLS	STATE	DISTRICT DAL	COUNTY VARIOUS	SHEET NO. 129
CHECK MA	CONTROL	SECTION	JOB	
CHECK BA	0095	14	033, ETC	

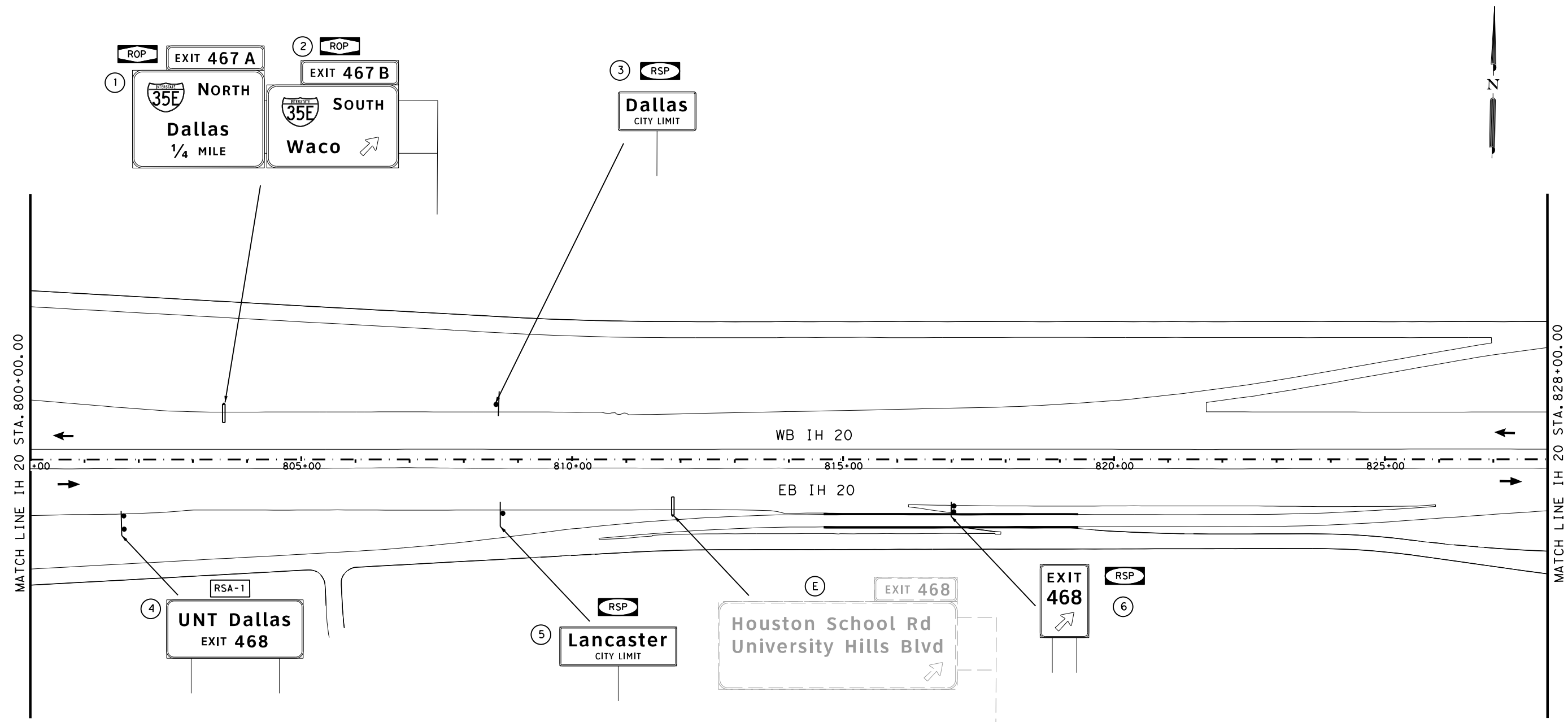

SIGNING LEGEND

- (E) EXISTING SIGN TO REMAIN
- (3) SIGN TO BE INSTALLED
- RSA REMOVE SMALL SIGN ASSEMBLY
- RLA-1 REMOVE LARGE GROUND ASSEMBLY
- RSP REPLACE SMALL SIGN PANEL
- RLP REPLACE LARGE SIGN PANEL
- ROP REPLACE OVERHEAD PANEL
- ROS-1 REMOVE OVERHEAD STRUCTURE

- * REMOVAL ITEMS THIS SHEET**
- (EA) SMALL SIGNS ASSEMBLY
 - (EA) OVERHEAD SIGNS
 - (EA) LARGE SIGNS ASSEMBLY
 - (EA) WALKWAY
- * Removal Quantities are Approximate and Contractor Will be Paid For Actual Work Performed**

INSTALL PROPOSED SIGNS
1 FT TO 2 FT BEHIND EXISTING
SIGN LOCATION,
UNLESS OTHERWISE NOTED.

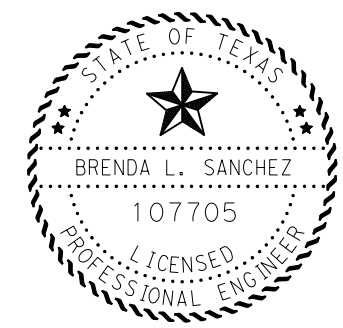

Brenda L Sanchez, P.E. 03/20/23
Signature of Registrant & Date

Texas Department of Transportation
© 2023

**SIGNING LAYOUT
IH 20**

SCALE: 1"=200' SHEET 26 OF 121

DESIGN/CK BLS	FED. RD. DIV. NO. 6	STATE PROJECT NO. (SEE TITLE SHEET)		HIGHWAY NO. IH 20
CHECK BLS	STATE	DISTRICT	COUNTY	SHEET NO.
CHECK MA	TEXAS	DAL	VARIOUS	130
CHECK BA	CONTROL	SECTION	JOB	
	0095	14	033, ETC	

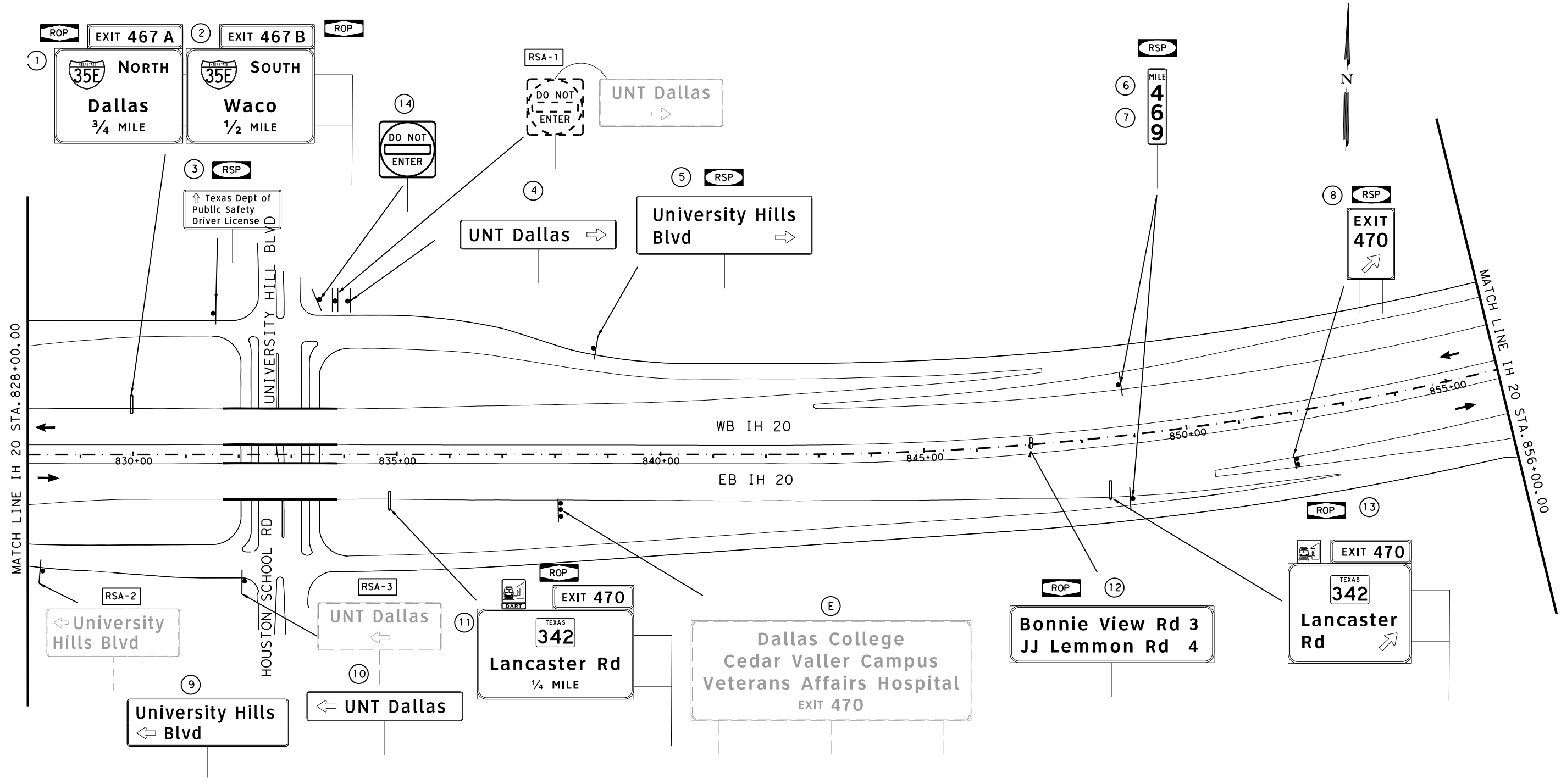

SIGNING LEGEND

- (E) EXISTING SIGN TO REMAIN
 - (3) SIGN TO BE INSTALLED
 - RSA REMOVE SMALL SIGN ASSEMBLY
 - RLA-1 REMOVE LARGE GROUND ASSEMBLY
 - RSP REPLACE SMALL SIGN PANEL
 - RLP REPLACE LARGE SIGN PANEL
 - ROP REPLACE OVERHEAD PANEL
 - ROS-1 REMOVE OVERHEAD STRUCTURE
-
- * REMOVAL ITEMS THIS SHEET
 - 3 (EA) SMALL SIGNS ASSEMBLY
 - (EA) OVERHEAD SIGNS
 - (EA) LARGE SIGNS ASSEMBLY
 - (EA) WALKWAY
- * Removal Quantities are Approximate and Contractor Will be Paid For Actual Work Performed

INSTALL PROPOSED SIGNS
1 FT TO 2 FT BEHIND EXISTING
SIGN LOCATION,
UNLESS OTHERWISE NOTED.

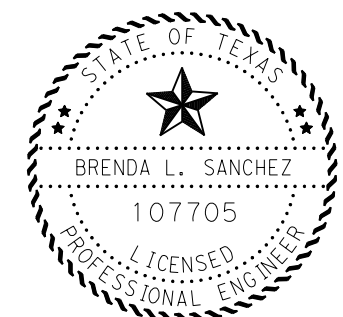

Brenda L Sanchez, P.E. 03/20/23
Signature of Registrar & Date

 Texas Department of Transportation © 2023				
SIGNING LAYOUT IH 20				
SCALE: 1"=200'			SHEET 27 OF 121	
DESIGN/CK BLS	FED. RD. DIV. NO. 6	STATE PROJECT NO. (SEE TITLE SHEET)		HIGHWAY NO. IH 20
CHECK BLS	STATE	DISTRICT DAL	COUNTY VARIOUS	SHEET NO. 131
CHECK MA	TEXAS	SECTION 0095	JOB 033, ETC	
CHECK BA	CONTROL	SECTION 14	JOB 033, ETC	

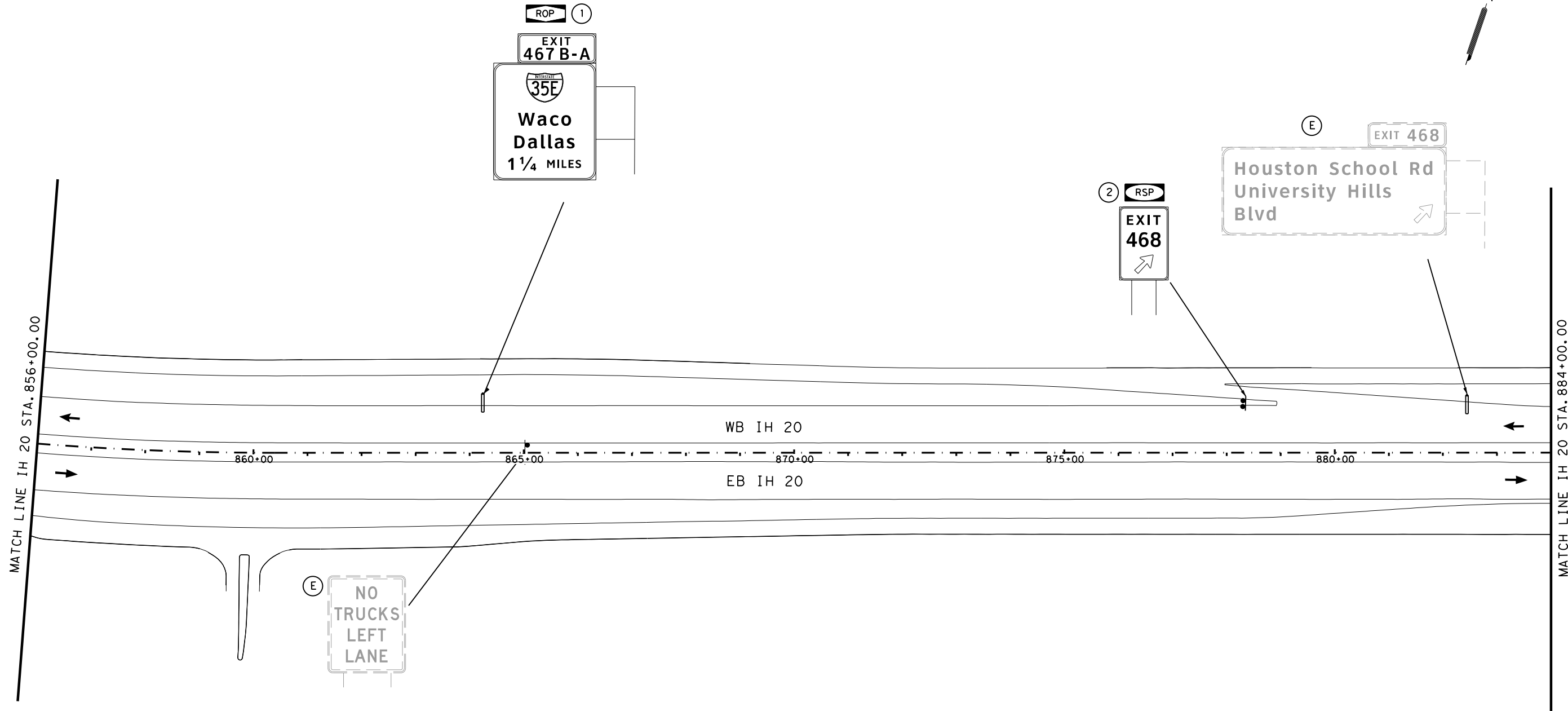

SIGNING LEGEND

- (E) EXISTING SIGN TO REMAIN
 - (3) SIGN TO BE INSTALLED
 - RSA REMOVE SMALL SIGN ASSEMBLY
 - RLA-1 REMOVE LARGE GROUND ASSEMBLY
 - RSP REPLACE SMALL SIGN PANEL
 - RLP REPLACE LARGE SIGN PANEL
 - ROP REPLACE OVERHEAD PANEL
 - ROS-1 REMOVE OVERHEAD STRUCTURE
-
- * REMOVAL ITEMS THIS SHEET
 - (EA) SMALL SIGNS ASSEMBLY
 - (EA) OVERHEAD SIGNS
 - (EA) LARGE SIGNS ASSEMBLY
 - (EA) WALKWAY
 - * Removal Quantities are Approximate and Contractor Will be Paid For Actual Work Performed

INSTALL PROPOSED SIGNS
1 FT TO 2 FT BEHIND EXISTING
SIGN LOCATION,
UNLESS OTHERWISE NOTED.



Brenda L Sanchez, P.E. 03/20/23
Signature of Registrant & Date

Texas Department of Transportation
© 2023

**SIGNING LAYOUT
IH 20**

SCALE: 1"=200' SHEET 28 OF 121

DESIGN/CK BLS	FED. RD. DIV. NO. 6	STATE PROJECT NO. (SEE TITLE SHEET)		HIGHWAY NO. IH 20
CHECK BLS	STATE	DISTRICT	COUNTY	SHEET NO.
CHECK MA	TEXAS	DAL	VARIOUS	132
CHECK BA	CONTROL	SECTION	JOB	
	0095	14	033, ETC	

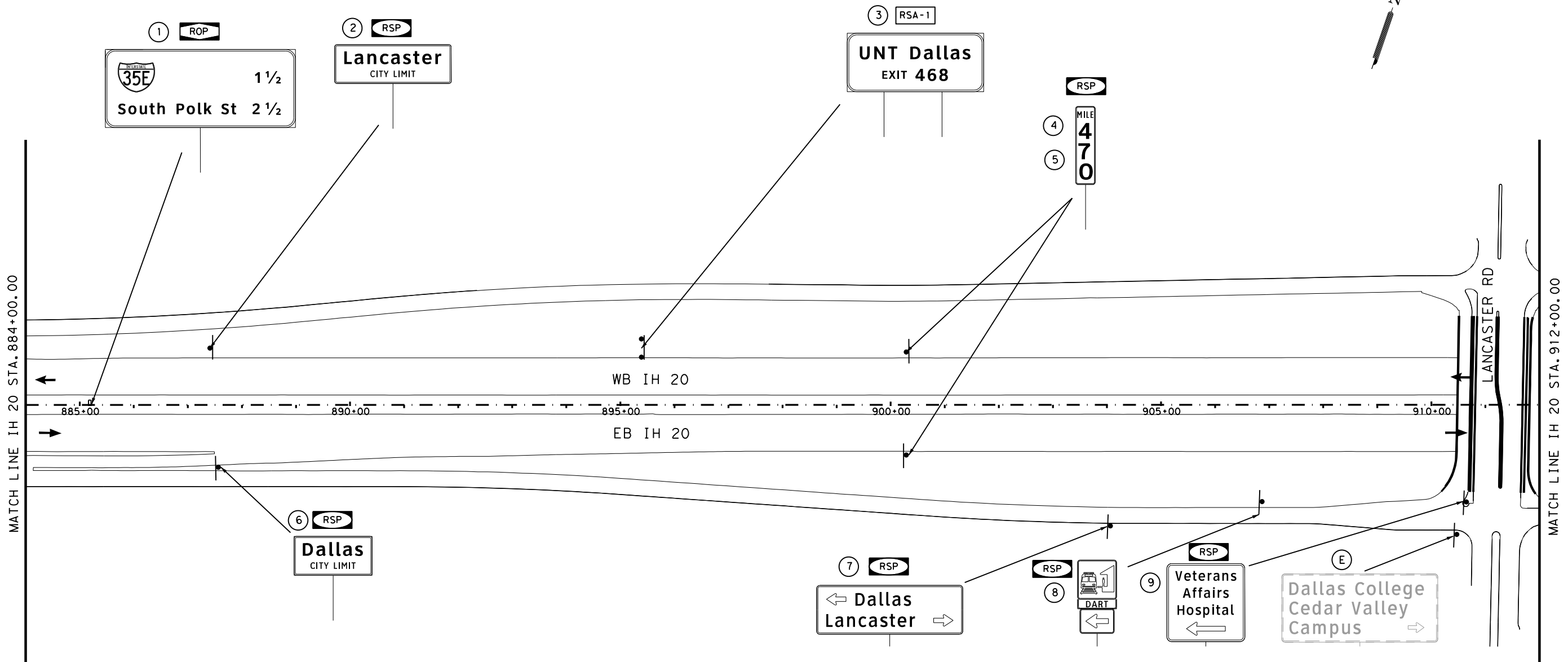
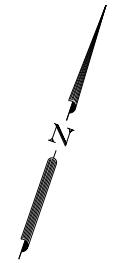

SIGNING LEGEND

- (E) EXISTING SIGN TO REMAIN
 - (3) SIGN TO BE INSTALLED
 - RSA REMOVE SMALL SIGN ASSEMBLY
 - RLA-1 REMOVE LARGE GROUND ASSEMBLY
 - RSP REPLACE SMALL SIGN PANEL
 - RLP REPLACE LARGE SIGN PANEL
 - ROP REPLACE OVERHEAD PANEL
 - ROS-1 REMOVE OVERHEAD STRUCTURE
-
- * REMOVAL ITEMS THIS SHEET
 - (EA) SMALL SIGNS ASSEMBLY
 - (EA) OVERHEAD SIGNS
 - (EA) LARGE SIGNS ASSEMBLY
 - (EA) WALKWAY
 - * Removal Quantities are Approximate and Contractor Will be Paid For Actual Work Performed

INSTALL PROPOSED SIGNS
1 FT TO 2 FT BEHIND EXISTING
SIGN LOCATION,
UNLESS OTHERWISE NOTED.

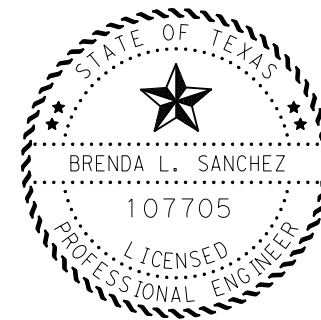

Brenda L Sanchez, P.E. 03/20/23
Signature of Registrar & Date

Texas Department of Transportation
© 2023

**SIGNING LAYOUT
IH 20**

SCALE: 1"=200' SHEET 29 OF 121

DESIGN/CK BLS	FED. RD. DIV. NO. 6	STATE PROJECT NO. (SEE TITLE SHEET)		HIGHWAY NO. IH 20
CHECK BLS	STATE	DISTRICT DAL	COUNTY VARIOUS	SHEET NO. 133
CHECK MA	TEXAS	SECTION 033, ETC	JOB	
CHECK BA	CONTROL 0095	SECTION 14	JOB	

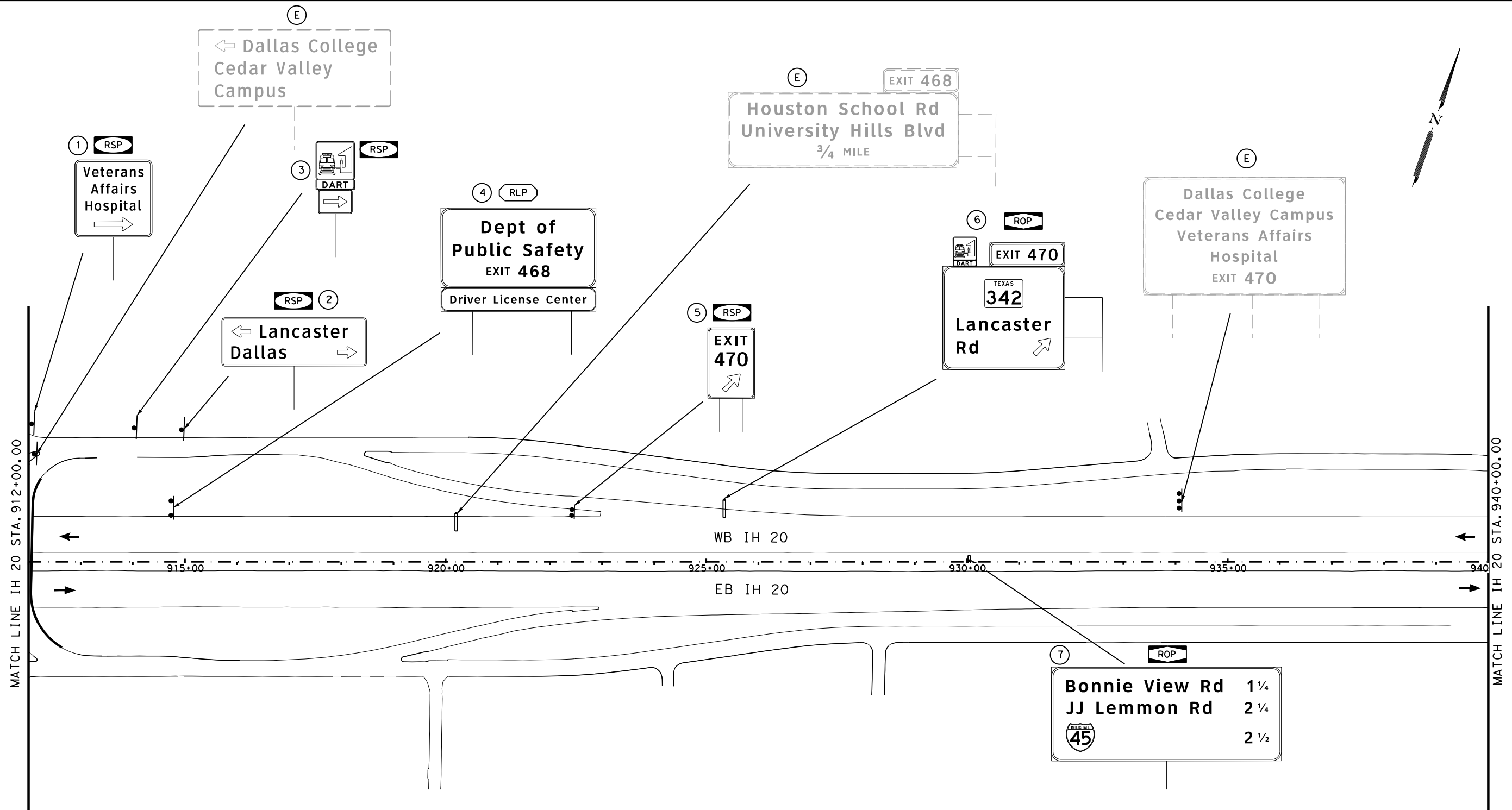

SIGNING LEGEND

- | | | |
|-------|------------------------------|-----------------------------|
| (E) | EXISTING SIGN TO REMAIN | * REMOVAL ITEMS THIS SHEET |
| (3) | SIGN TO BE INSTALLED | — (EA) SMALL SIGNS ASSEMBLY |
| RSA | REMOVE SMALL SIGN ASSEMBLY | — (EA) OVERHEAD SIGNS |
| RLA-1 | REMOVE LARGE GROUND ASSEMBLY | — (EA) LARGE SIGNS ASSEMBLY |
| RSP | REPLACE SMALL SIGN PANEL | — (EA) WALKWAY |
| RLP | REPLACE LARGE SIGN PANEL | * Removal Quantities are |
| ROP | REPLACE OVERHEAD PANEL | Approximate and Contractor |
| ROS-1 | REMOVE OVERHEAD STRUCTURE | Will be Paid For Actual |
| | | Work Performed |

INSTALL PROPOSED SIGNS
1 FT TO 2 FT BEHIND EXISTING
SIGN LOCATION,
UNLESS OTHERWISE NOTED.

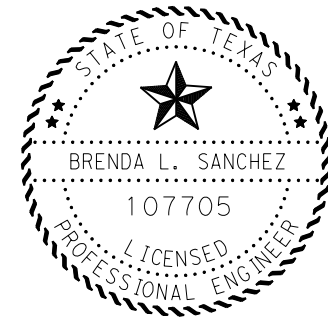

Brenda L Sanchez, P.E. 03/20/23
Signature of Registrar & Date



**SIGNING LAYOUT
IH 20**

SCALE: 1"=200' SHEET 30 OF 121

DESIGN/CK BLS	FED. RD. DIV. NO. 6	STATE PROJECT NO. (SEE TITLE SHEET)		HIGHWAY NO. IH 20
CHECK BLS	STATE	DISTRICT	COUNTY	SHEET NO.
CHECK MA	TEXAS	DAL	VARIOUS	134
CHECK BA	CONTROL	SECTION	JOB	
	0095	14	033, ETC	

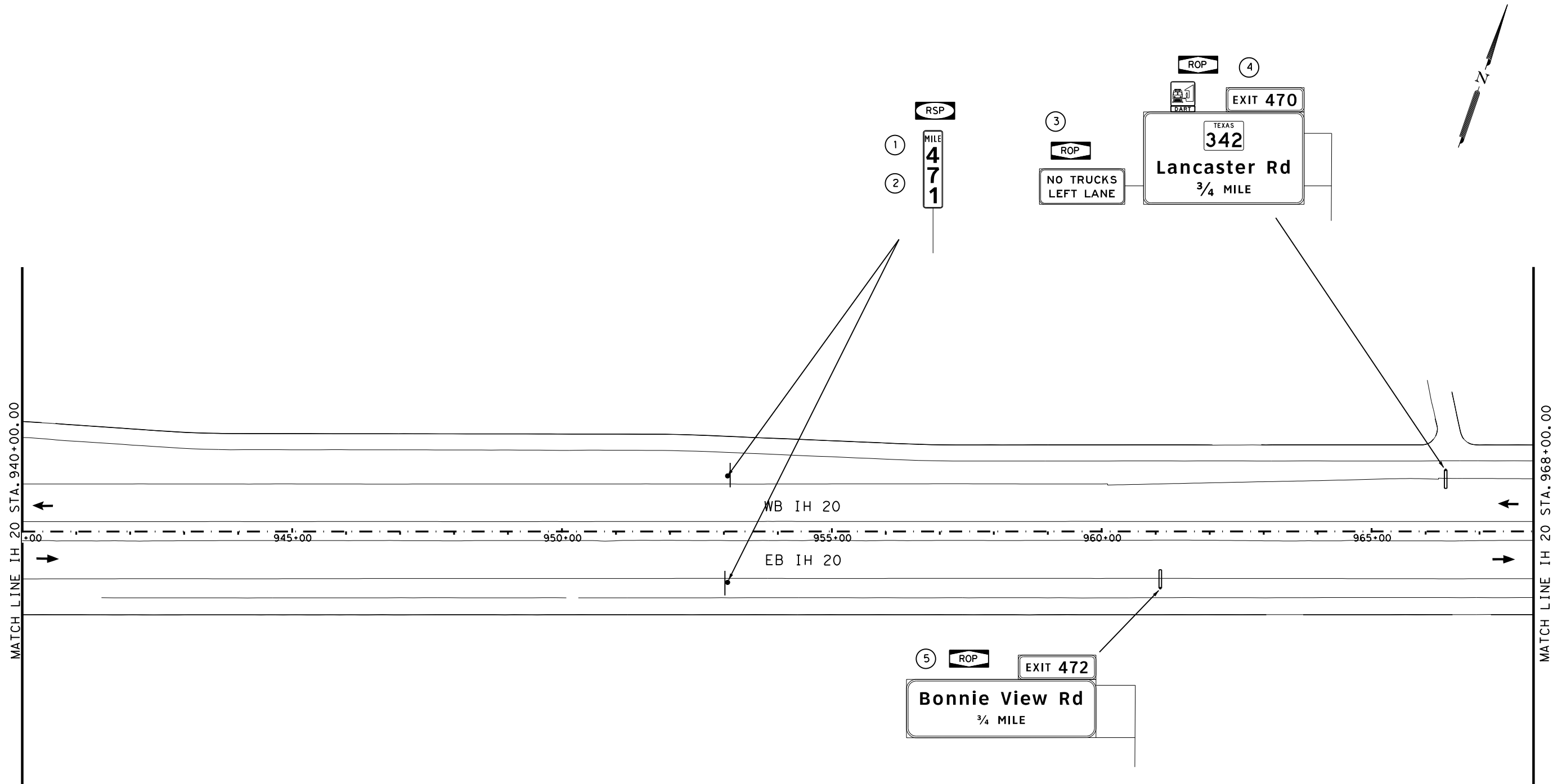

SIGNING LEGEND

- (E) EXISTING SIGN TO REMAIN
- (3) SIGN TO BE INSTALLED
- RSA REMOVE SMALL SIGN ASSEMBLY
- RLA-1 REMOVE LARGE GROUND ASSEMBLY
- RSP REPLACE SMALL SIGN PANEL
- RLP REPLACE LARGE SIGN PANEL
- ROP REPLACE OVERHEAD PANEL
- ROS-1 REMOVE OVERHEAD STRUCTURE

- * REMOVAL ITEMS THIS SHEET
- (EA) SMALL SIGNS ASSEMBLY
 - (EA) OVERHEAD SIGNS
 - (EA) LARGE SIGNS ASSEMBLY
 - (EA) WALKWAY
- * Removal Quantities are Approximate and Contractor Will be Paid For Actual Work Performed

INSTALL PROPOSED SIGNS
1 FT TO 2 FT BEHIND EXISTING
SIGN LOCATION,
UNLESS OTHERWISE NOTED.



Brenda L Sanchez, P.E. 03/20/23
Signature of Registrar & Date

Texas Department of Transportation
© 2023

**SIGNING LAYOUT
IH 20**

SCALE: 1"=200' SHEET 31 OF 121

DESIGN/CK BLS	FED. RD. DIV. NO. 6	STATE PROJECT NO. (SEE TITLE SHEET)		HIGHWAY NO. IH 20
CHECK BLS	STATE	DISTRICT DAL	COUNTY VARIOUS	SHEET NO. 135
CHECK MA	TEXAS	SECTION 14	JOB 033, ETC	
CHECK BA	CONTROL 0095			

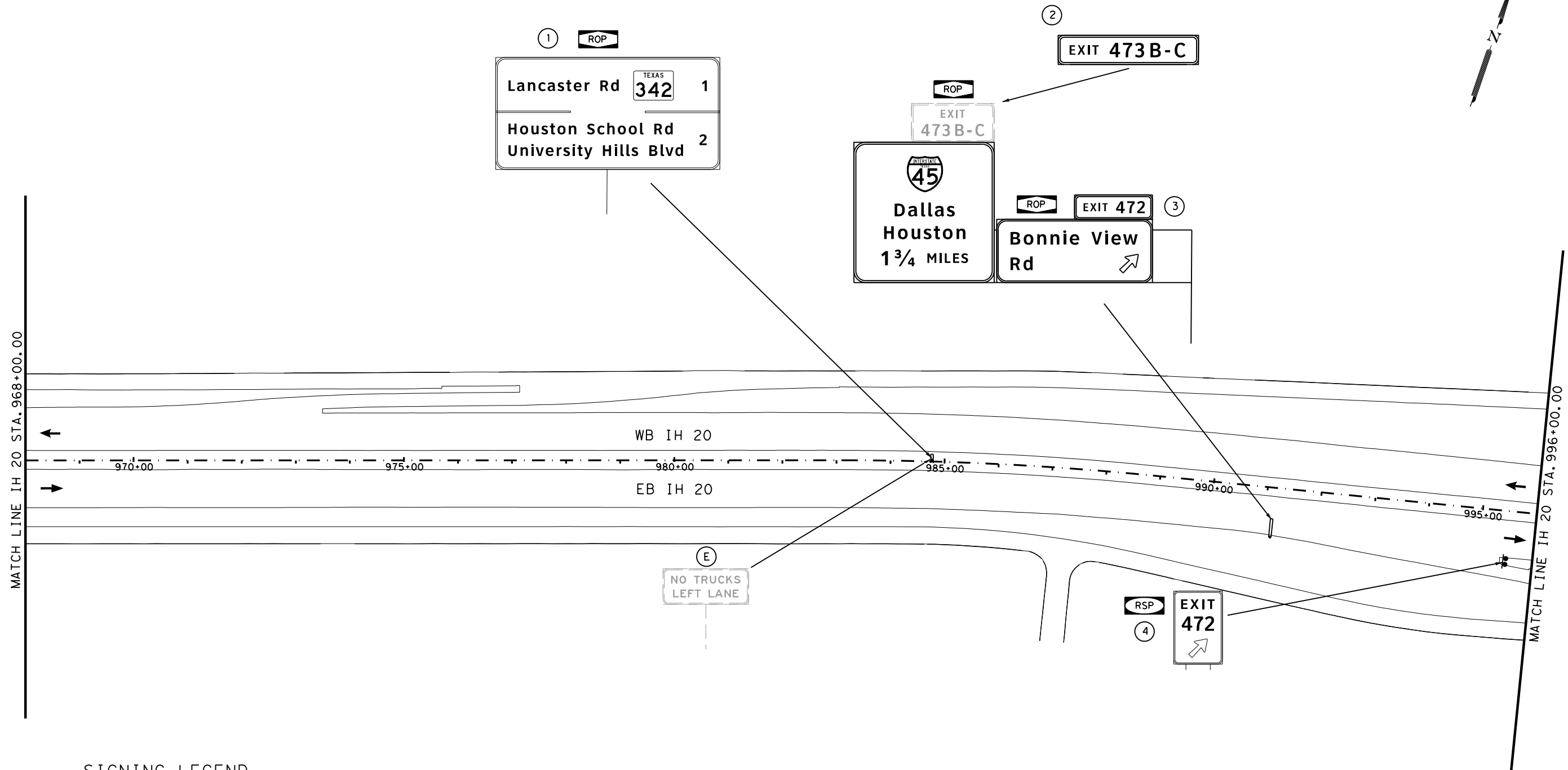

SIGNING LEGEND

- (E) EXISTING SIGN TO REMAIN
 - (3) SIGN TO BE INSTALLED
 - RSA REMOVE SMALL SIGN ASSEMBLY
 - RLA-1 REMOVE LARGE GROUND ASSEMBLY
 - RSP REPLACE SMALL SIGN PANEL
 - RLP REPLACE LARGE SIGN PANEL
 - ROP REPLACE OVERHEAD PANEL
 - ROS-1 REMOVE OVERHEAD STRUCTURE
-
- * REMOVAL ITEMS THIS SHEET
 - (EA) SMALL SIGNS ASSEMBLY
 - (EA) OVERHEAD SIGNS
 - (EA) LARGE SIGNS ASSEMBLY
 - (EA) WALKWAY
-
- * Removal Quantities are Approximate and Contractor Will be Paid For Actual Work Performed

INSTALL PROPOSED SIGNS
1 FT TO 2 FT BEHIND EXISTING
SIGN LOCATION,
UNLESS OTHERWISE NOTED.



Brenda L Sanchez, P.E. 03/20/23
Signature of Registrar & Date

Texas Department of Transportation
© 2023

**SIGNING LAYOUT
IH 20**

SCALE: 1"=200' SHEET 32 OF 121

DESIGN/CK BLS	FED. RD. DIV. NO. 6	STATE PROJECT NO. (SEE TITLE SHEET)		HIGHWAY NO. IH 20
CHECK BLS	STATE	DISTRICT	COUNTY	SHEET NO.
CHECK MA	TEXAS	DAL	VARIOUS	136
CHECK BA	CONTROL	SECTION	JOB	
	0095	14	033, ETC	

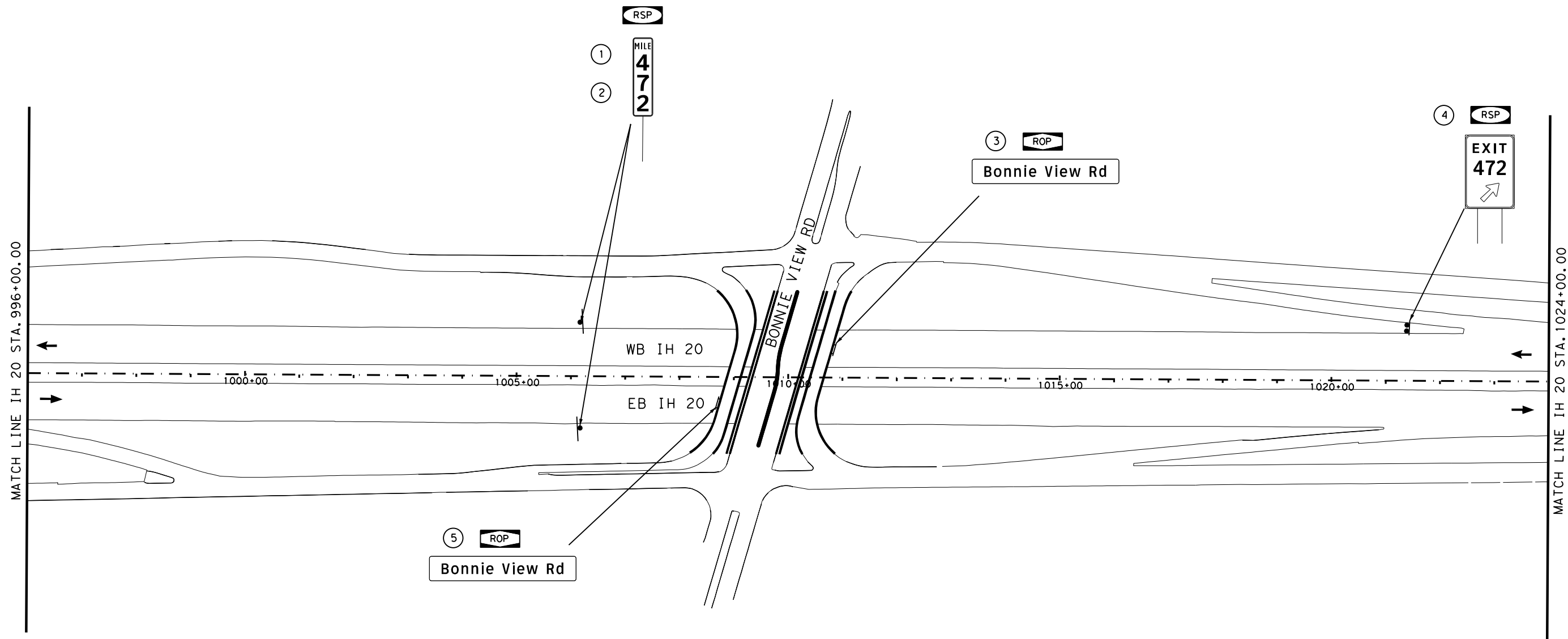

SIGNING LEGEND

- (E) EXISTING SIGN TO REMAIN
- (3) SIGN TO BE INSTALLED
- RSA REMOVE SMALL SIGN ASSEMBLY
- RLA-1 REMOVE LARGE GROUND ASSEMBLY
- RSP REPLACE SMALL SIGN PANEL
- RLP REPLACE LARGE SIGN PANEL
- ROP REPLACE OVERHEAD PANEL
- ROS-1 REMOVE OVERHEAD STRUCTURE

- * REMOVAL ITEMS THIS SHEET
- (EA) SMALL SIGNS ASSEMBLY
 - (EA) OVERHEAD SIGNS
 - (EA) LARGE SIGNS ASSEMBLY
 - (EA) WALKWAY
- * Removal Quantities are Approximate and Contractor Will be Paid For Actual Work Performed

INSTALL PROPOSED SIGNS
1 FT TO 2 FT BEHIND EXISTING
SIGN LOCATION,
UNLESS OTHERWISE NOTED.

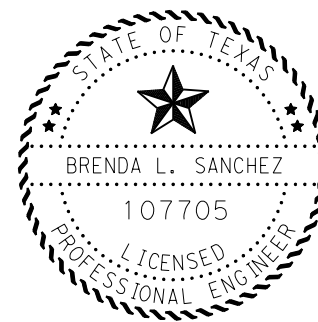

Brenda L. Sanchez, P.E. 03/20/23
Signature of Registrant & Date

 Texas Department of Transportation © 2023				
SIGNING LAYOUT IH 20				
SCALE: 1"=200'			SHEET 33 OF 121	
DESIGN/CK BLS	FED. RD. DIV. NO. 6	STATE PROJECT NO. (SEE TITLE SHEET)		HIGHWAY NO. IH 20
CHECK BLS	STATE	DISTRICT DAL	COUNTY	SHEET NO. 137
CHECK MA	TEXAS	SECTION	VARIOUS	
CHECK BA	CONTROL 0095	JOB 14	033, ETC	

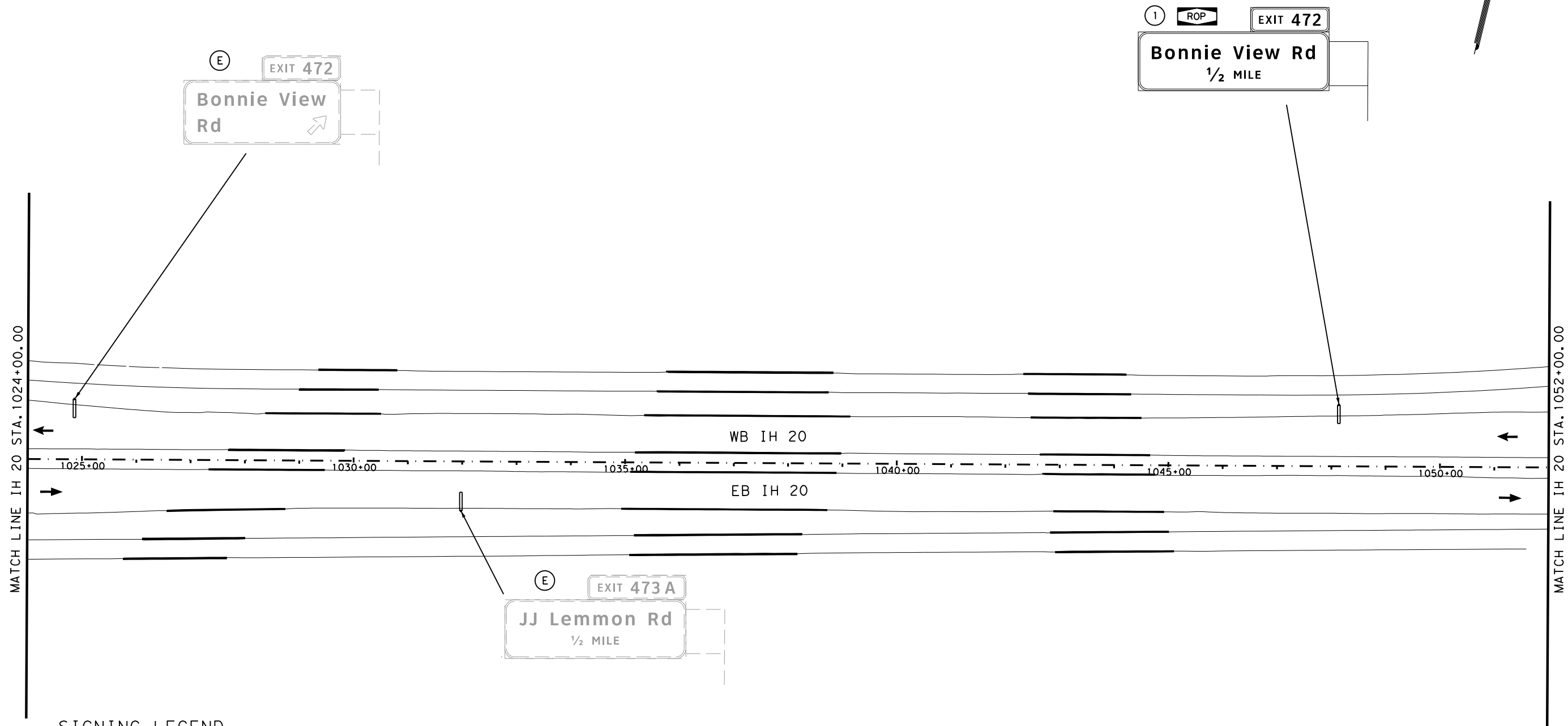

SIGNING LEGEND

- (E) EXISTING SIGN TO REMAIN
 - (3) SIGN TO BE INSTALLED
 - RSA REMOVE SMALL SIGN ASSEMBLY
 - RLA-1 REMOVE LARGE GROUND ASSEMBLY
 - RSP REPLACE SMALL SIGN PANEL
 - RLP REPLACE LARGE SIGN PANEL
 - ROP REPLACE OVERHEAD PANEL
 - ROS-1 REMOVE OVERHEAD STRUCTURE
-
- * REMOVAL ITEMS THIS SHEET
 - (EA) SMALL SIGNS ASSEMBLY
 - (EA) OVERHEAD SIGNS
 - (EA) LARGE SIGNS ASSEMBLY
 - (EA) WALKWAY
-
- * Removal Quantities are Approximate and Contractor Will be Paid For Actual Work Performed

INSTALL PROPOSED SIGNS
1 FT TO 2 FT BEHIND EXISTING
SIGN LOCATION,
UNLESS OTHERWISE NOTED.



Brenda L. Sanchez, P.E. 03/20/23
Signature of Registrant & Date

Texas Department of Transportation
© 2023

SIGNING LAYOUT IH 20

SCALE: 1"=200' SHEET 34 OF 121

DESIGN/CK BLS	FED. RD. DIV. NO. 6	STATE PROJECT NO. (SEE TITLE SHEET)		HIGHWAY NO. IH 20
CHECK BLS	STATE	DISTRICT DAL	COUNTY VARIOUS	SHEET NO. 138
CHECK MA	CONTROL 0095	SECTION 14	JOB 033, ETC	
CHECK BA				

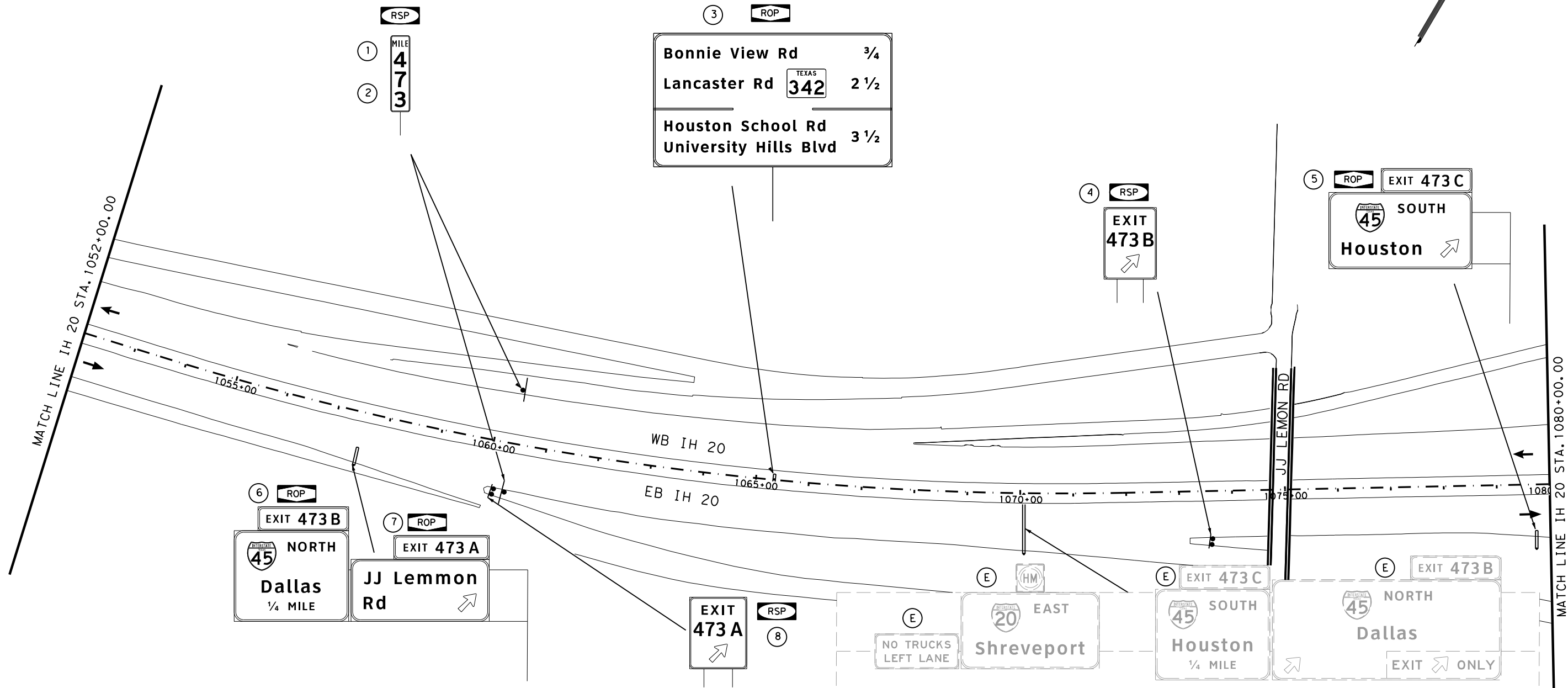

SIGNING LEGEND

- (E) EXISTING SIGN TO REMAIN
 - (3) SIGN TO BE INSTALLED
 - RSA REMOVE SMALL SIGN ASSEMBLY
 - RLA-1 REMOVE LARGE GROUND ASSEMBLY
 - RSP REPLACE SMALL SIGN PANEL
 - RLP REPLACE LARGE SIGN PANEL
 - ROP REPLACE OVERHEAD PANEL
 - ROS-1 REMOVE OVERHEAD STRUCTURE
-
- * REMOVAL ITEMS THIS SHEET
 - (EA) SMALL SIGNS ASSEMBLY
 - (EA) OVERHEAD SIGNS
 - (EA) LARGE SIGNS ASSEMBLY
 - (EA) WALKWAY
-
- * Removal Quantities are Approximate and Contractor Will be Paid For Actual Work Performed

INSTALL PROPOSED SIGNS
1 FT TO 2 FT BEHIND EXISTING
SIGN LOCATION,
UNLESS OTHERWISE NOTED.



Brenda L Sanchez, P.E. 03/20/23
Signature of Registrar & Date



**SIGNING LAYOUT
IH 20**

SCALE: 1"=200' SHEET 35 OF 121

DESIGN/CK BLS	FED. RD. DIV. NO. 6	STATE PROJECT NO. (SEE TITLE SHEET)		HIGHWAY NO. IH 20
CHECK BLS	STATE	DISTRICT	COUNTY	SHEET NO.
CHECK MA	TEXAS	DAL	VARIOUS	139
CHECK BA	CONTROL	SECTION	JOB	
	0095	14	033, ETC	

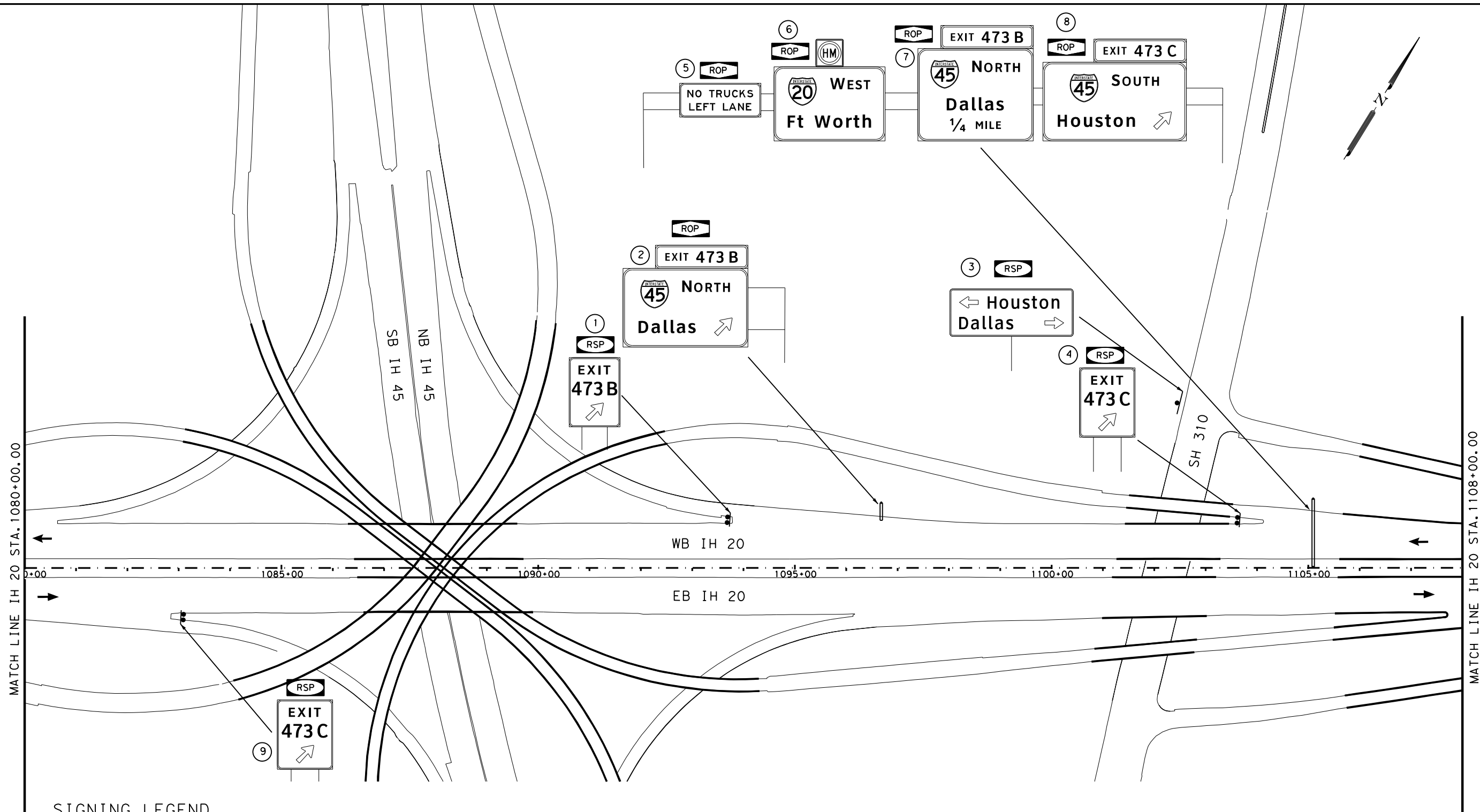

SIGNING LEGEND

- (E) EXISTING SIGN TO REMAIN
- (3) SIGN TO BE INSTALLED
- RSA REMOVE SMALL SIGN ASSEMBLY
- RLA-1 REMOVE LARGE GROUND ASSEMBLY
- RSP REPLACE SMALL SIGN PANEL
- RLP REPLACE LARGE SIGN PANEL
- ROP REPLACE OVERHEAD PANEL
- ROS-1 REMOVE OVERHEAD STRUCTURE

- * REMOVAL ITEMS THIS SHEET
- (EA) SMALL SIGNS ASSEMBLY
- (EA) OVERHEAD SIGNS
- (EA) LARGE SIGNS ASSEMBLY
- (EA) WALKWAY
- * Removal Quantities are Approximate and Contractor Will be Paid For Actual Work Performed

INSTALL PROPOSED SIGNS
1 FT TO 2 FT BEHIND EXISTING
SIGN LOCATION,
UNLESS OTHERWISE NOTED.

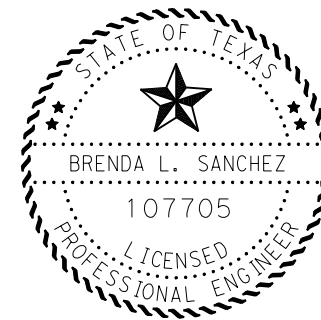

Brenda L Sanchez, P.E. 03/20/23
Signature of Registrant & Date

Texas Department of Transportation
© 2023

**SIGNING LAYOUT
IH 20**

SCALE: 1"=200' SHEET 36 OF 121

DESIGN/CK BLS	FED. RD. DIV. NO. 6	STATE PROJECT NO. (SEE TITLE SHEET)		HIGHWAY NO. IH 20
CHECK BLS	STATE	DISTRICT DAL	COUNTY VARIOUS	SHEET NO. 140
CHECK MA	CONTROL	SECTION	JOB	
CHECK BA	0095	14	033, ETC	

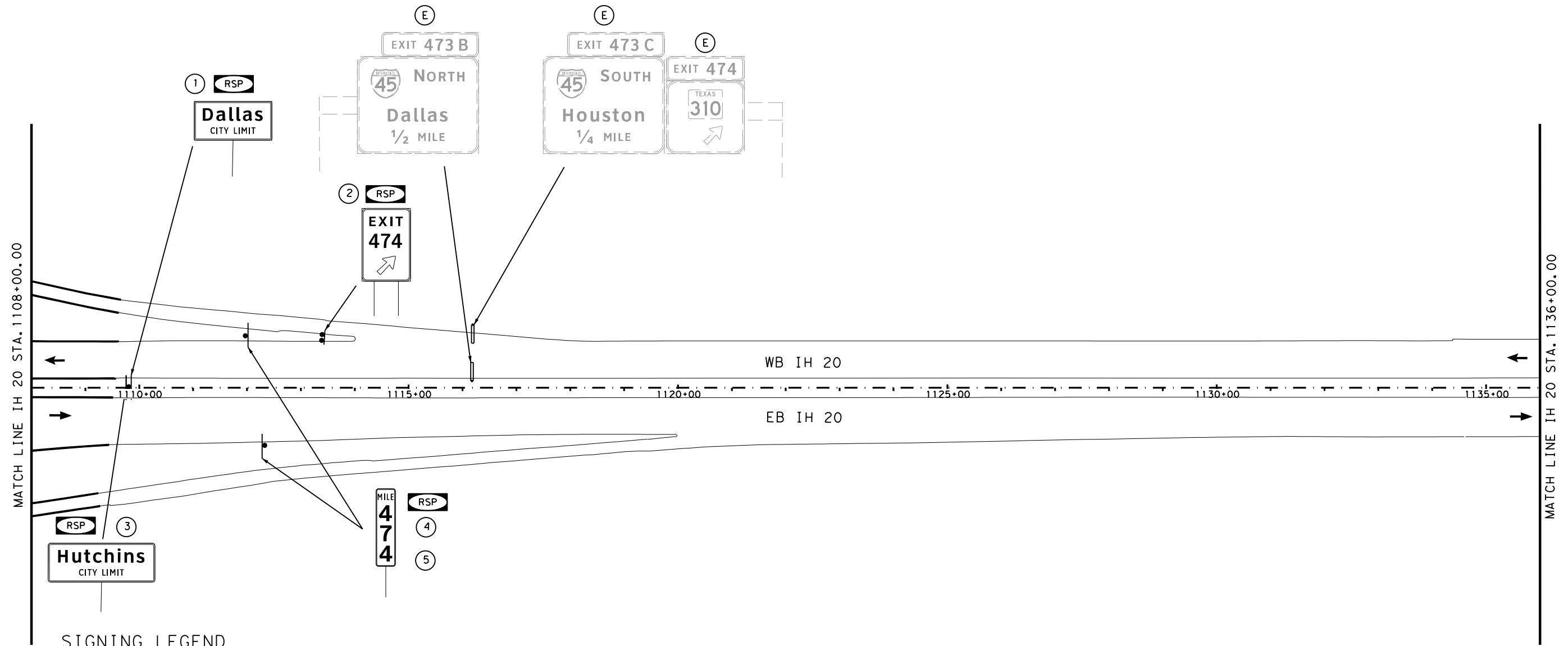
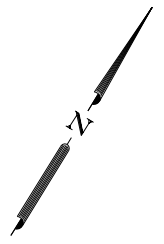

SIGNING LEGEND

- (E) EXISTING SIGN TO REMAIN
 - (3) SIGN TO BE INSTALLED
 - RSA REMOVE SMALL SIGN ASSEMBLY
 - RLA-1 REMOVE LARGE GROUND ASSEMBLY
 - RSP REPLACE SMALL SIGN PANEL
 - RLP REPLACE LARGE SIGN PANEL
 - ROP REPLACE OVERHEAD PANEL
 - ROS-1 REMOVE OVERHEAD STRUCTURE
-
- * REMOVAL ITEMS THIS SHEET
 - (EA) SMALL SIGNS ASSEMBLY
 - (EA) OVERHEAD SIGNS
 - (EA) LARGE SIGNS ASSEMBLY
 - (EA) WALKWAY
-
- * Removal Quantities are Approximate and Contractor Will be Paid For Actual Work Performed

INSTALL PROPOSED SIGNS
1 FT TO 2 FT BEHIND EXISTING
SIGN LOCATION,
UNLESS OTHERWISE NOTED.



Brenda L Sanchez, P.E. 03/20/23
Signature of Registrar & Date

Texas Department of Transportation
© 2023

SIGNING LAYOUT IH 20

SCALE: 1"=200' SHEET 37 OF 121

DESIGN/CK BLS	FED. RD. DIV. NO. 6	STATE PROJECT NO. (SEE TITLE SHEET)		HIGHWAY NO. IH 20
CHECK BLS	STATE	DISTRICT	COUNTY	SHEET NO.
CHECK MA	TEXAS	DAL	VARIOUS	141
CHECK BA	CONTROL	SECTION	JOB	
	0095	14	033, ETC	

MATCH LINE IH 20 STA. 1136+00.00

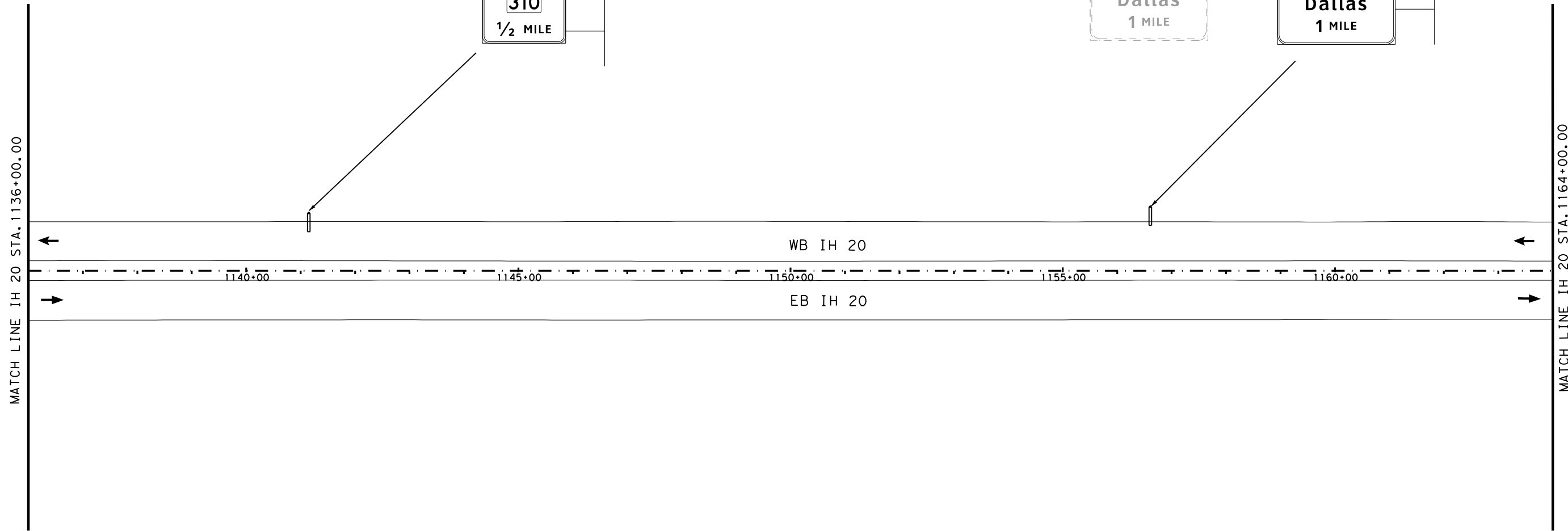

SIGNING LEGEND

- (E) EXISTING SIGN TO REMAIN
- (3) SIGN TO BE INSTALLED
- RSA REMOVE SMALL SIGN ASSEMBLY
- RLA-1 REMOVE LARGE GROUND ASSEMBLY
- RSP REPLACE SMALL SIGN PANEL
- RLP REPLACE LARGE SIGN PANEL
- ROP REPLACE OVERHEAD PANEL
- ROS-1 REMOVE OVERHEAD STRUCTURE

- * REMOVAL ITEMS THIS SHEET
- (EA) SMALL SIGNS ASSEMBLY
- (EA) OVERHEAD SIGNS
- (EA) LARGE SIGNS ASSEMBLY
- (EA) WALKWAY
- * Removal Quantities are Approximate and Contractor Will be Paid For Actual Work Performed

INSTALL PROPOSED SIGNS
1 FT TO 2 FT BEHIND EXISTING
SIGN LOCATION,
UNLESS OTHERWISE NOTED.

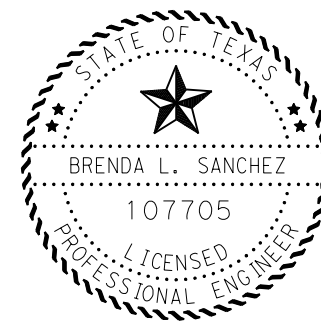

Brenda L Sanchez, P.E. 03/20/23
Signature of Registrant & Date

Texas Department of Transportation
© 2023

**SIGNING LAYOUT
IH 20**

SCALE: 1"=200' SHEET 38 OF 121

DESIGN/CK BLS	FED. RD. DIV. NO. 6	STATE PROJECT NO. (SEE TITLE SHEET)		HIGHWAY NO. IH 20
CHECK BLS	STATE	DISTRICT	COUNTY	SHEET NO.
CHECK MA	TEXAS	DAL	VARIOUS	142
CHECK BA	CONTROL	SECTION	JOB	
	0095	14	033, ETC	

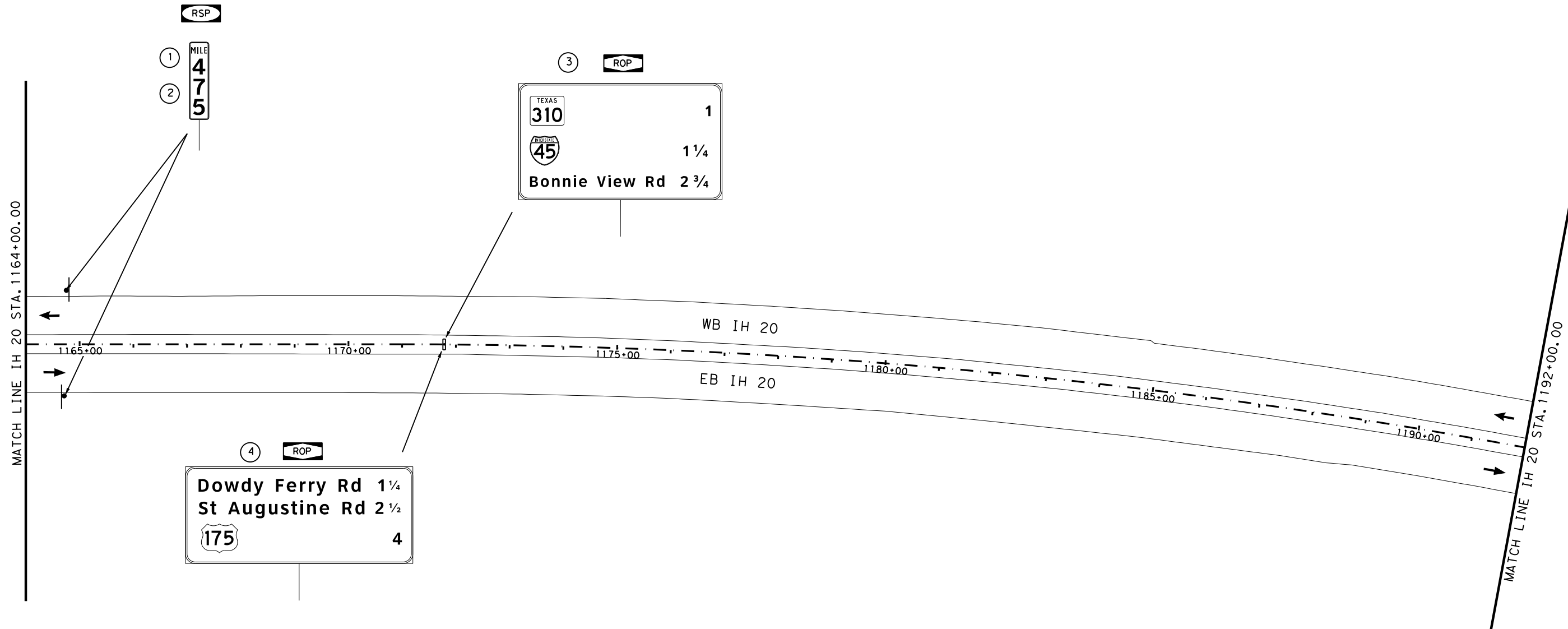

SIGNING LEGEND

- (E) EXISTING SIGN TO REMAIN
 - (3) SIGN TO BE INSTALLED
 - RSA REMOVE SMALL SIGN ASSEMBLY
 - RLA-1 REMOVE LARGE GROUND ASSEMBLY
 - RSP REPLACE SMALL SIGN PANEL
 - RLP REPLACE LARGE SIGN PANEL
 - ROP REPLACE OVERHEAD PANEL
 - ROS-1 REMOVE OVERHEAD STRUCTURE
-
- * REMOVAL ITEMS THIS SHEET
 - (EA) SMALL SIGNS ASSEMBLY
 - (EA) OVERHEAD SIGNS
 - (EA) LARGE SIGNS ASSEMBLY
 - (EA) WALKWAY
-
- * Removal Quantities are Approximate and Contractor Will be Paid For Actual Work Performed

INSTALL PROPOSED SIGNS
1 FT TO 2 FT BEHIND EXISTING
SIGN LOCATION,
UNLESS OTHERWISE NOTED.



Brenda L Sanchez, P.E. 03/20/23
Signature of Registrant & Date

Texas Department of Transportation
© 2023

SIGNING LAYOUT IH 20

SCALE: 1"=200' SHEET 39 OF 121

DESIGN/CK BLS	FED. RD. DIV. NO. 6	STATE PROJECT NO. (SEE TITLE SHEET)		HIGHWAY NO. IH 20
CHECK BLS	STATE	DISTRICT DAL	COUNTY VARIOUS	SHEET NO. 143
CHECK MA	CONTROL	SECTION	JOB	
CHECK BA	0095	14	033, ETC	

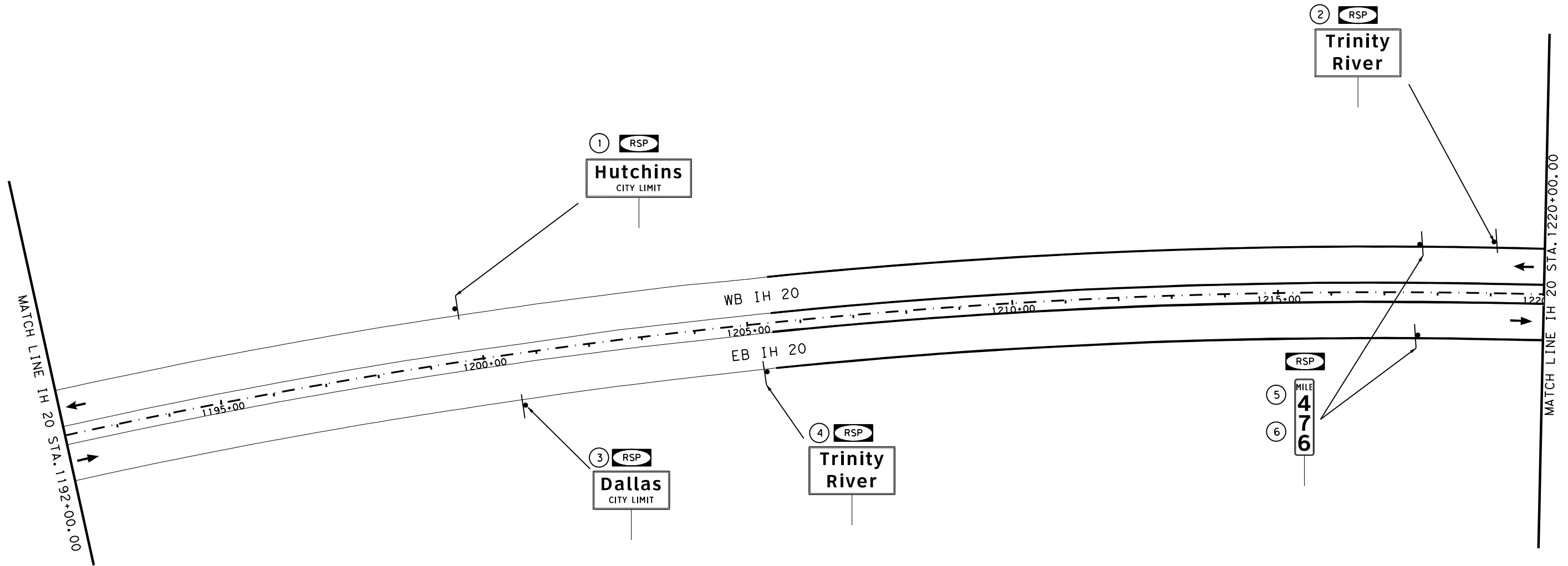

SIGNING LEGEND

- (E) EXISTING SIGN TO REMAIN
- (3) SIGN TO BE INSTALLED
- RSA REMOVE SMALL SIGN ASSEMBLY
- RLA-1 REMOVE LARGE GROUND ASSEMBLY
- RSP REPLACE SMALL SIGN PANEL
- RLP REPLACE LARGE SIGN PANEL
- ROP REPLACE OVERHEAD PANEL
- ROS-1 REMOVE OVERHEAD STRUCTURE

- * REMOVAL ITEMS THIS SHEET
- (EA) SMALL SIGNS ASSEMBLY
 - (EA) OVERHEAD SIGNS
 - (EA) LARGE SIGNS ASSEMBLY
 - (EA) WALKWAY
- * Removal Quantities are Approximate and Contractor Will be Paid For Actual Work Performed

INSTALL PROPOSED SIGNS
1 FT TO 2 FT BEHIND EXISTING
SIGN LOCATION,
UNLESS OTHERWISE NOTED.

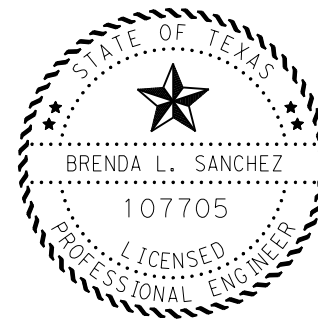

Brenda L Sanchez, P.E. 03/20/23
Signature of Registrant & Date

Texas Department of Transportation
© 2023

**SIGNING LAYOUT
IH 20**

SCALE: 1"=200' SHEET 40 OF 121

DESIGN/CK BLS	FED. RD. DIV. NO. 6	STATE PROJECT NO. (SEE TITLE SHEET)		HIGHWAY NO. IH 20
CHECK BLS	STATE	DISTRICT DAL	COUNTY VARIOUS	SHEET NO. 144
CHECK MA	CONTROL 0095	SECTION 14	JOB 033, ETC	
CHECK BA				

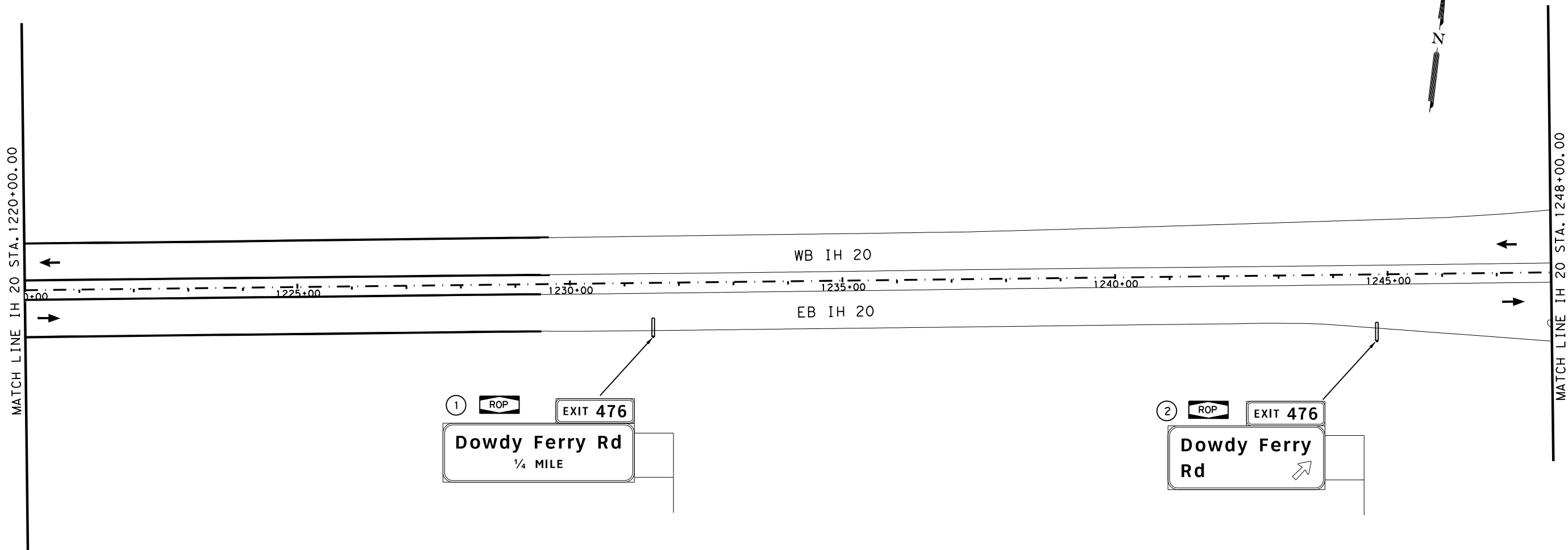

SIGNING LEGEND

- (E) EXISTING SIGN TO REMAIN
- (3) SIGN TO BE INSTALLED
- RSA REMOVE SMALL SIGN ASSEMBLY
- RLA-1 REMOVE LARGE GROUND ASSEMBLY
- RSP REPLACE SMALL SIGN PANEL
- RLP REPLACE LARGE SIGN PANEL
- ROP REPLACE OVERHEAD PANEL
- ROS-1 REMOVE OVERHEAD STRUCTURE

- * REMOVAL ITEMS THIS SHEET
- (EA) SMALL SIGNS ASSEMBLY
- (EA) OVERHEAD SIGNS
- (EA) LARGE SIGNS ASSEMBLY
- (EA) WALKWAY
- * Removal Quantities are Approximate and Contractor Will be Paid For Actual Work Performed

INSTALL PROPOSED SIGNS
1 FT TO 2 FT BEHIND EXISTING
SIGN LOCATION,
UNLESS OTHERWISE NOTED.

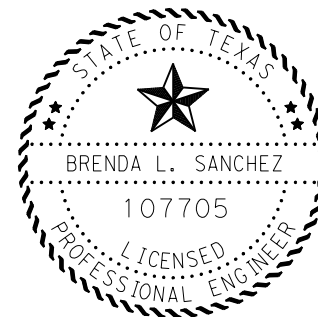

Brenda L Sanchez, P.E. 03/20/23
Signature of Registrant & Date

 Texas Department of Transportation © 2023			
SIGNING LAYOUT IH 20			
SCALE: 1"=200'			SHEET 41 OF 121
DESIGN/CK BLS	FED. RD. DIV. NO. 6	STATE PROJECT NO. (SEE TITLE SHEET)	
CHECK BLS	STATE	DISTRICT DAL	COUNTY VARIOUS
CHECK MA	CONTROL	SECTION	JOB
CHECK BA	0095	14	033, ETC
			145

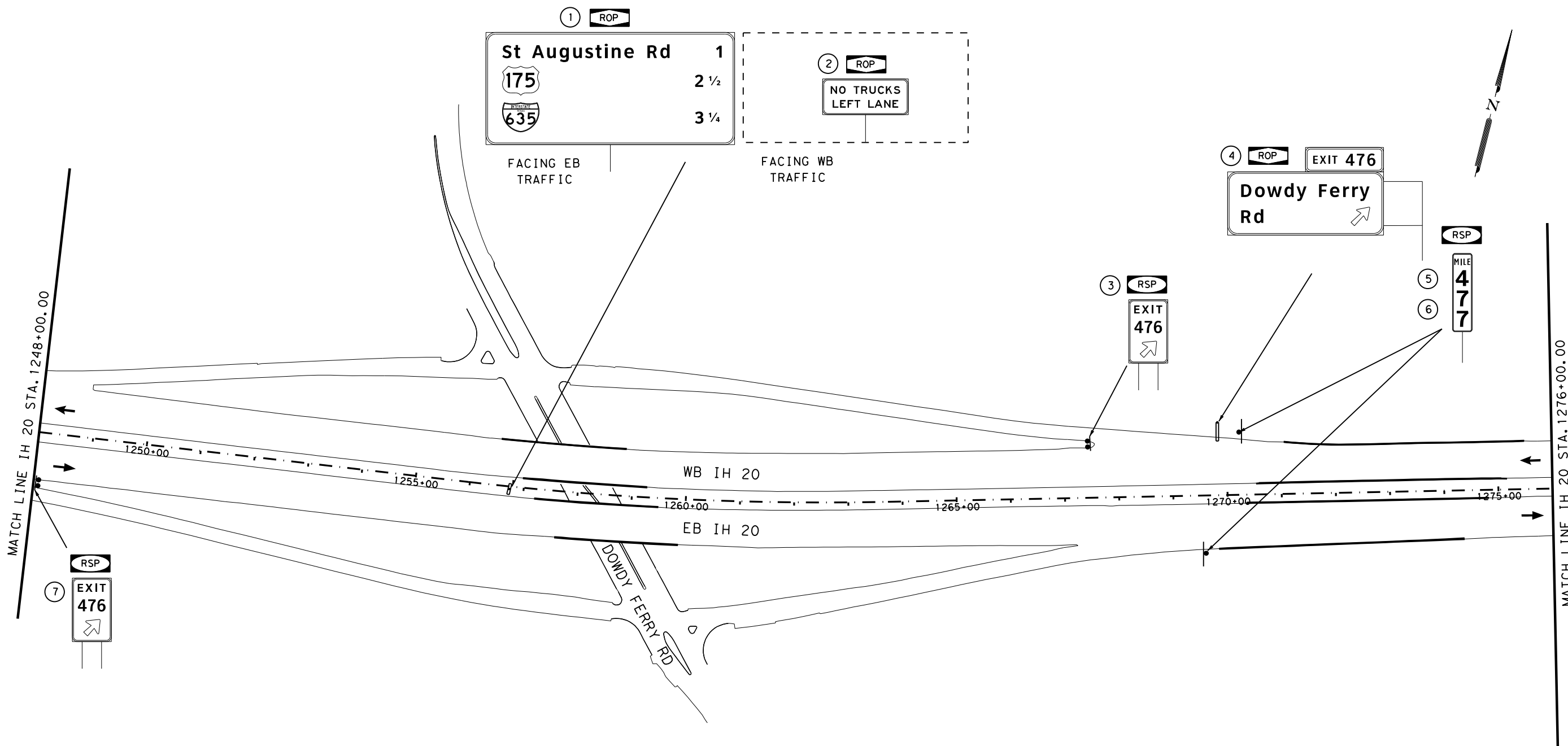

SIGNING LEGEND

- | | | | |
|-------|------------------------------|---|----------------------------|
| (E) | EXISTING SIGN TO REMAIN | | |
| (3) | SIGN TO BE INSTALLED | | |
| RSA | REMOVE SMALL SIGN ASSEMBLY | — | (EA) SMALL SIGNS ASSEMBLY |
| RLA-1 | REMOVE LARGE GROUND ASSEMBLY | — | (EA) OVERHEAD SIGNS |
| RSP | REPLACE SMALL SIGN PANEL | — | (EA) LARGE SIGNS ASSEMBLY |
| RLP | REPLACE LARGE SIGN PANEL | — | (EA) WALKWAY |
| ROP | REPLACE OVERHEAD PANEL | * | Removal Quantities are |
| ROS-1 | REMOVE OVERHEAD STRUCTURE | | Approximate and Contractor |
| | | | Will be Paid For Actual |
| | | | Work Performed |

INSTALL PROPOSED SIGNS
 1 FT TO 2 FT BEHIND EXISTING
 SIGN LOCATION,
 UNLESS OTHERWISE NOTED.



Brenda L Sanchez, P.E. 03/20/23
 Signature of Registrar & Date

Texas Department of Transportation
 © 2023

SIGNING LAYOUT
IH 20

SCALE: 1"=200' SHEET 42 OF 121

DESIGN/CK BLS	FED. RD. DIV. NO. 6	STATE PROJECT NO. (SEE TITLE SHEET)		HIGHWAY NO. IH 20
CHECK BLS	STATE	DISTRICT	COUNTY	SHEET NO.
CHECK MA	TEXAS	DAL	VARIOUS	146
CHECK BA	CONTROL	SECTION	JOB	
	0095	14	033, ETC	

MATCH LINE IH 20 STA. 1276+00.00

MATCH LINE IH 20 STA. 1304+00.00

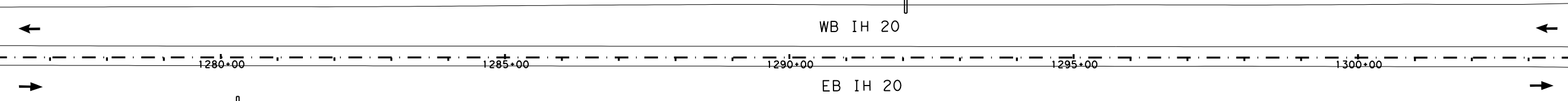

SIGNING LEGEND

- (E) EXISTING SIGN TO REMAIN
 - (3) SIGN TO BE INSTALLED
 - RSA REMOVE SMALL SIGN ASSEMBLY
 - RLA-1 REMOVE LARGE GROUND ASSEMBLY
 - RSP REPLACE SMALL SIGN PANEL
 - RLP REPLACE LARGE SIGN PANEL
 - ROP REPLACE OVERHEAD PANEL
 - ROS-1 REMOVE OVERHEAD STRUCTURE
-
- * REMOVAL ITEMS THIS SHEET
 - (EA) SMALL SIGNS ASSEMBLY
 - (EA) OVERHEAD SIGNS
 - (EA) LARGE SIGNS ASSEMBLY
 - (EA) WALKWAY
 - * Removal Quantities are Approximate and Contractor Will be Paid For Actual Work Performed

INSTALL PROPOSED SIGNS
1 FT TO 2 FT BEHIND EXISTING
SIGN LOCATION,
UNLESS OTHERWISE NOTED.

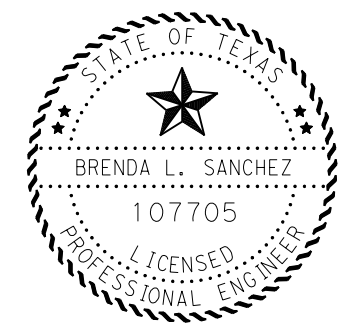

Brenda L. Sanchez, P.E. 03/20/23
Signature of Registrar & Date

Texas Department of Transportation
© 2023

**SIGNING LAYOUT
IH 20**

SCALE: 1"=200' SHEET 43 OF 121

DESIGN/CK BLS	FED. RD. DIV. NO. 6	STATE PROJECT NO. (SEE TITLE SHEET)		HIGHWAY NO. IH 20
CHECK BLS	STATE	DISTRICT DAL	COUNTY VARIOUS	SHEET NO. 147
CHECK MA	TEXAS	SECTION CONTROL	JOB VARIOUS	
CHECK BA	0095	14	033, ETC	

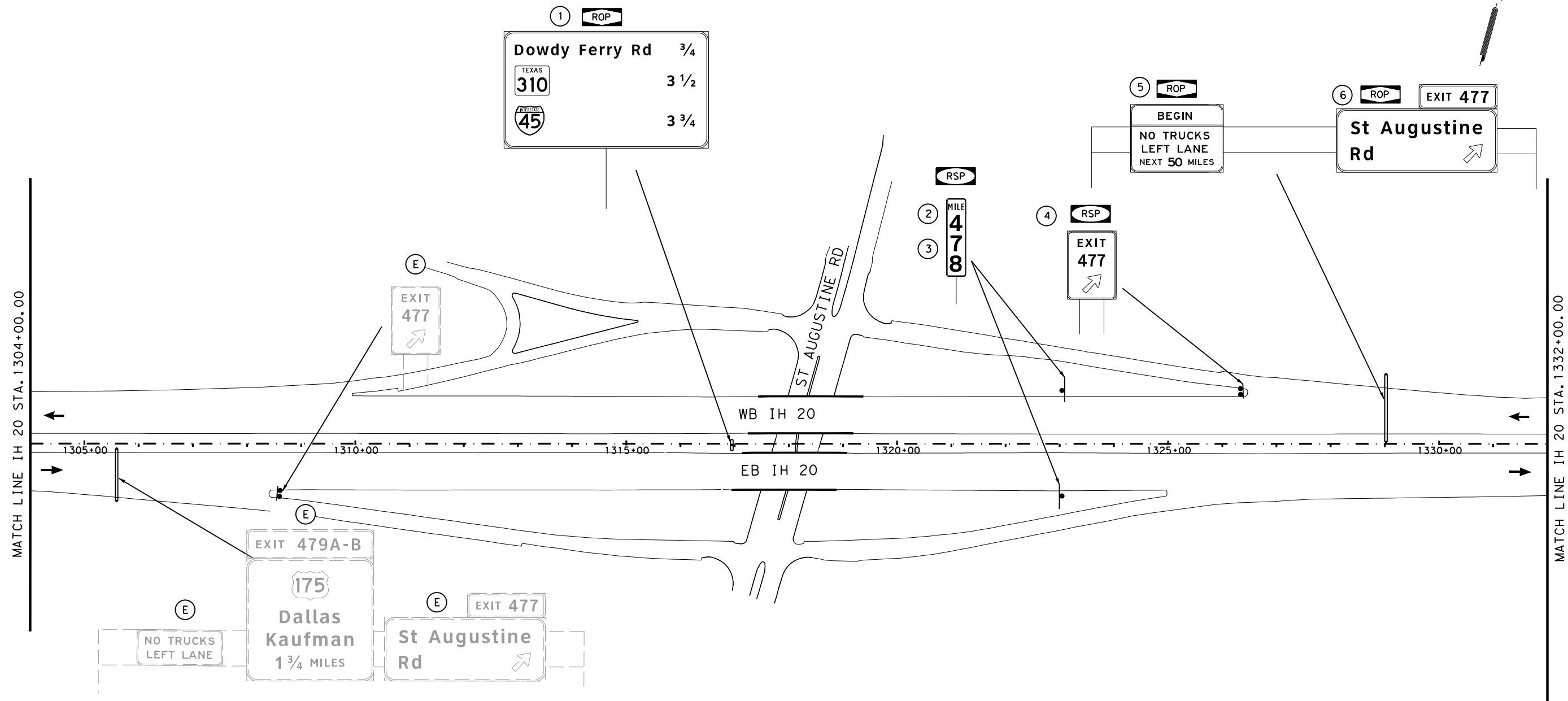

SIGNING LEGEND

- (E) EXISTING SIGN TO REMAIN
 - (3) SIGN TO BE INSTALLED
 - RSA REMOVE SMALL SIGN ASSEMBLY
 - RLA-1 REMOVE LARGE GROUND ASSEMBLY
 - RSP REPLACE SMALL SIGN PANEL
 - RLP REPLACE LARGE SIGN PANEL
 - ROP REPLACE OVERHEAD PANEL
 - ROS-1 REMOVE OVERHEAD STRUCTURE
-
- * REMOVAL ITEMS THIS SHEET
 - (EA) SMALL SIGNS ASSEMBLY
 - (EA) OVERHEAD SIGNS
 - (EA) LARGE SIGNS ASSEMBLY
 - (EA) WALKWAY
-
- * Removal Quantities are Approximate and Contractor Will be Paid For Actual Work Performed

INSTALL PROPOSED SIGNS
1 FT TO 2 FT BEHIND EXISTING
SIGN LOCATION,
UNLESS OTHERWISE NOTED.

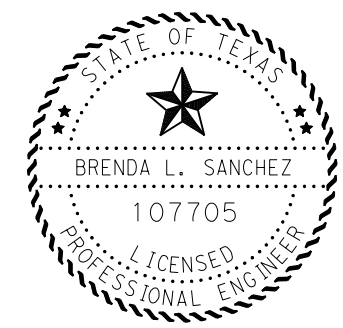

Brenda L Sanchez, P.E. 03/20/23
Signature of Registrant & Date



Texas Department of Transportation
© 2023

**SIGNING LAYOUT
IH 20**

SCALE: 1"=200' SHEET 44 OF 121

DESIGN/CK BLS	FED. RD. DIV. NO. 6	STATE PROJECT NO. (SEE TITLE SHEET)		HIGHWAY NO. IH 20
CHECK BLS	STATE	DISTRICT DAL	COUNTY VARIOUS	SHEET NO. 148
CHECK MA	CONTROL	SECTION 14	JOB 033, ETC	
CHECK BA	0095			

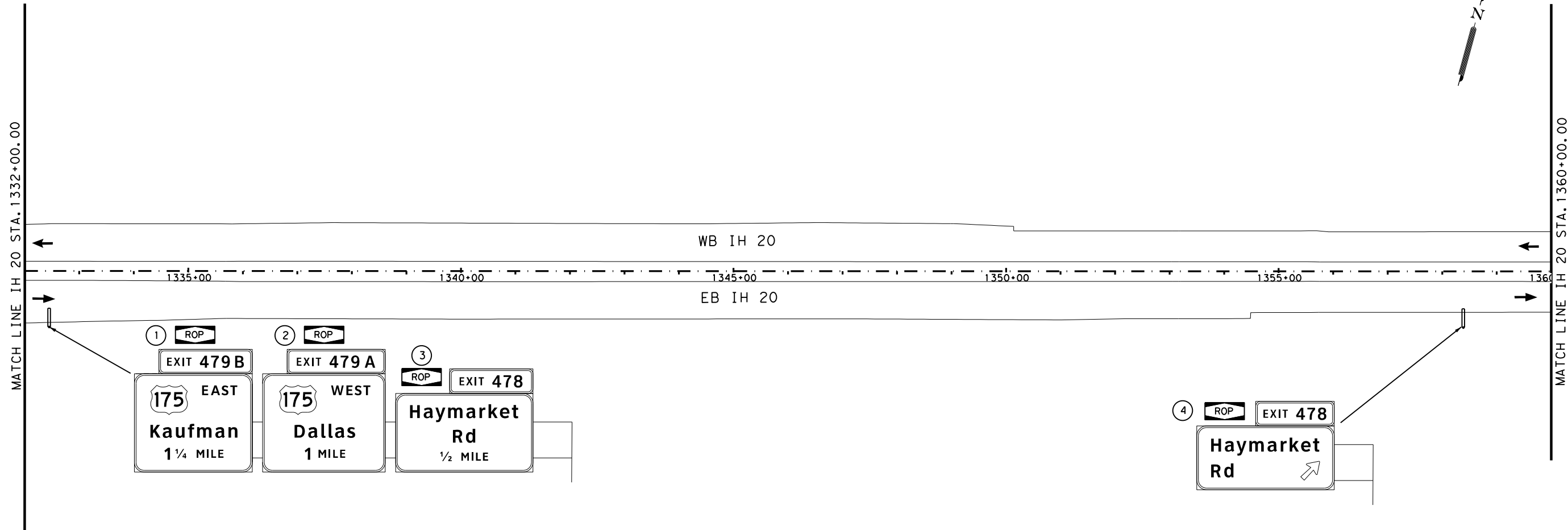

SIGNING LEGEND

- (E) EXISTING SIGN TO REMAIN
 - (3) SIGN TO BE INSTALLED
 - RSA REMOVE SMALL SIGN ASSEMBLY
 - RLA-1 REMOVE LARGE GROUND ASSEMBLY
 - RSP REPLACE SMALL SIGN PANEL
 - RLP REPLACE LARGE SIGN PANEL
 - ROP REPLACE OVERHEAD PANEL
 - ROS-1 REMOVE OVERHEAD STRUCTURE
-
- * REMOVAL ITEMS THIS SHEET
 - (EA) SMALL SIGNS ASSEMBLY
 - (EA) OVERHEAD SIGNS
 - (EA) LARGE SIGNS ASSEMBLY
 - (EA) WALKWAY
 - * Removal Quantities are Approximate and Contractor Will be Paid For Actual Work Performed

INSTALL PROPOSED SIGNS
1 FT TO 2 FT BEHIND EXISTING
SIGN LOCATION,
UNLESS OTHERWISE NOTED.

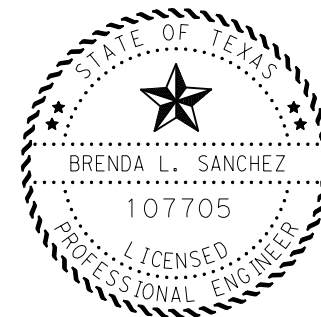

Brenda L. Sanchez, P.E. 03/20/23
Signature of Registrar & Date

Texas Department of Transportation
© 2023

**SIGNING LAYOUT
IH 20**

SCALE: 1"=200' SHEET 45 OF 121

DESIGN/CK BLS	FED. RD. DIV. NO. 6	STATE PROJECT NO. (SEE TITLE SHEET)		HIGHWAY NO. IH 20
CHECK BLS	STATE	DISTRICT DAL	COUNTY VARIOUS	SHEET NO. 149
CHECK MA	TEXAS	SECTION 14	JOB 033, ETC	
CHECK BA	CONTROL 0095			

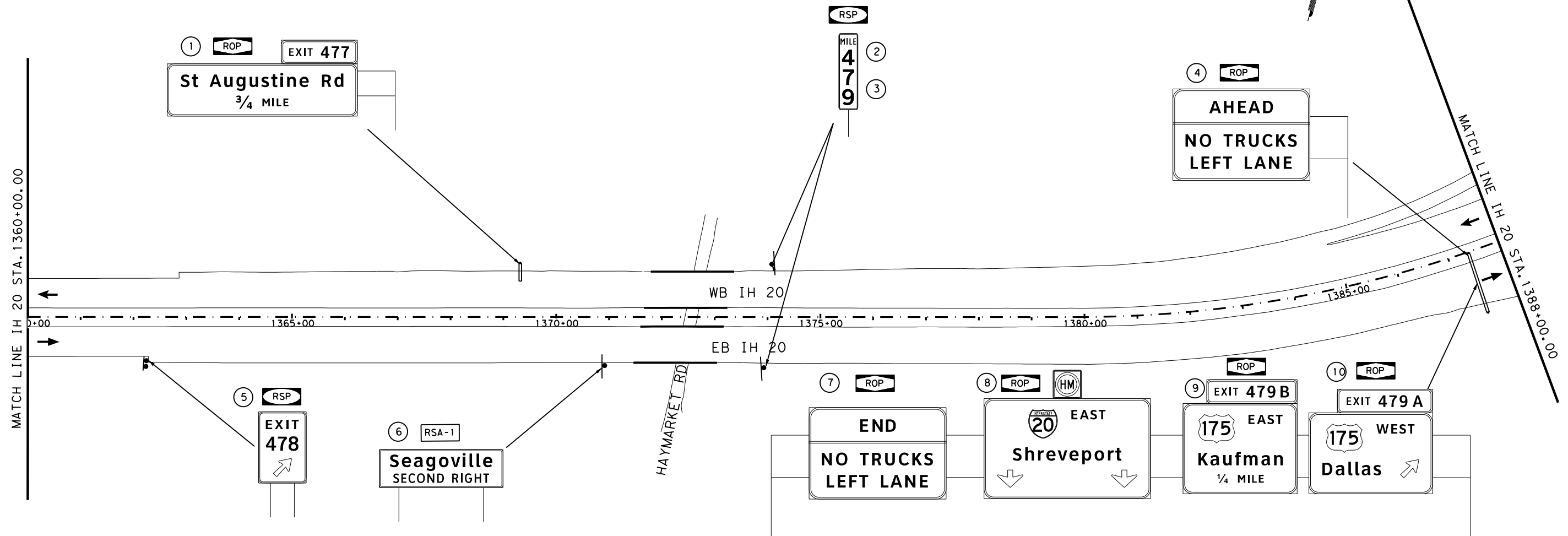

SIGNING LEGEND

- (E) EXISTING SIGN TO REMAIN
- (3) SIGN TO BE INSTALLED
- RSA REMOVE SMALL SIGN ASSEMBLY
- RLA-1 REMOVE LARGE GROUND ASSEMBLY
- RSP REPLACE SMALL SIGN PANEL
- RLP REPLACE LARGE SIGN PANEL
- ROP REPLACE OVERHEAD PANEL
- ROS-1 REMOVE OVERHEAD STRUCTURE

- * REMOVAL ITEMS THIS SHEET
- (EA) SMALL SIGNS ASSEMBLY
 - (EA) OVERHEAD SIGNS
 - (EA) LARGE SIGNS ASSEMBLY
 - (EA) WALKWAY
- * Removal Quantities are Approximate and Contractor Will be Paid For Actual Work Performed

INSTALL PROPOSED SIGNS
1 FT TO 2 FT BEHIND EXISTING
SIGN LOCATION,
UNLESS OTHERWISE NOTED.

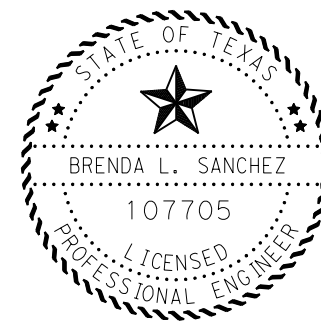

Brenda L Sanchez, P.E. 03/20/23
Signature of Registrar & Date

Texas Department of Transportation
© 2023

**SIGNING LAYOUT
IH 20**

SCALE: 1"=200' SHEET 46 OF 121

DESIGN/CK BLS	FED. RD. DIV. NO. 6	STATE PROJECT NO. (SEE TITLE SHEET)		HIGHWAY NO. IH 20
CHECK BLS	STATE	DISTRICT DAL	COUNTY VARIOUS	SHEET NO. 150
CHECK MA	CONTROL 0095	SECTION 14	JOB 033, ETC	
CHECK BA				

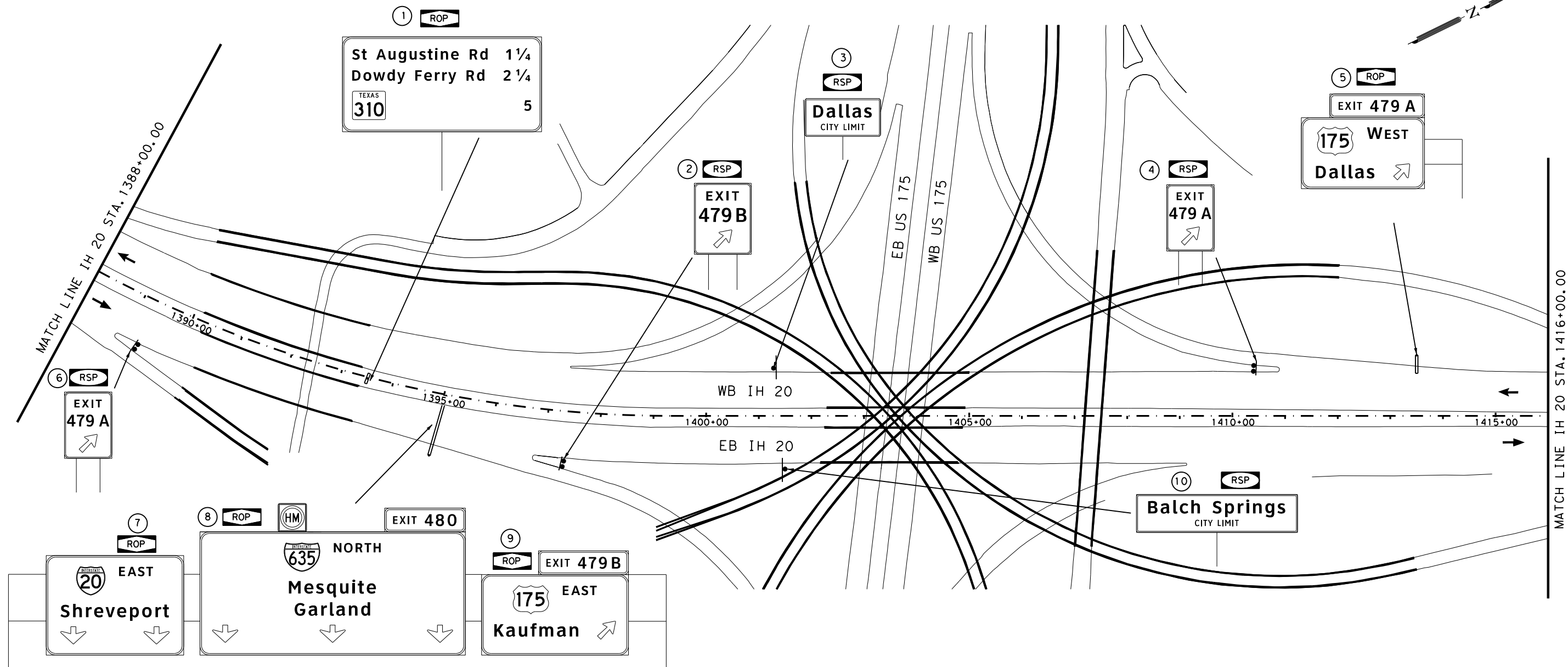

SIGNING LEGEND

- (E) EXISTING SIGN TO REMAIN
 - (3) SIGN TO BE INSTALLED
 - RSA REMOVE SMALL SIGN ASSEMBLY
 - RLA-1 REMOVE LARGE GROUND ASSEMBLY
 - RSP REPLACE SMALL SIGN PANEL
 - RLP REPLACE LARGE SIGN PANEL
 - ROP REPLACE OVERHEAD PANEL
 - ROS-1 REMOVE OVERHEAD STRUCTURE
-
- * REMOVAL ITEMS THIS SHEET
 - (EA) SMALL SIGNS ASSEMBLY
 - (EA) OVERHEAD SIGNS
 - (EA) LARGE SIGNS ASSEMBLY
 - (EA) WALKWAY
-
- * Removal Quantities are Approximate and Contractor Will be Paid For Actual Work Performed

INSTALL PROPOSED SIGNS
1 FT TO 2 FT BEHIND EXISTING
SIGN LOCATION,
UNLESS OTHERWISE NOTED.



Brenda L Sanchez, P.E. 03/20/23
Signature of Registrant & Date



**SIGNING LAYOUT
IH 20**

SCALE: 1"=200' SHEET 47 OF 121

DESIGN/CK BLS	FED. RD. DIV. NO. 6	STATE PROJECT NO. (SEE TITLE SHEET)		HIGHWAY NO. IH 20
CHECK BLS	STATE	DISTRICT	COUNTY	SHEET NO.
CHECK MA	TEXAS	DAL	VARIOUS	151
CHECK BA	CONTROL	SECTION	JOB	
	0095	14	033, ETC	

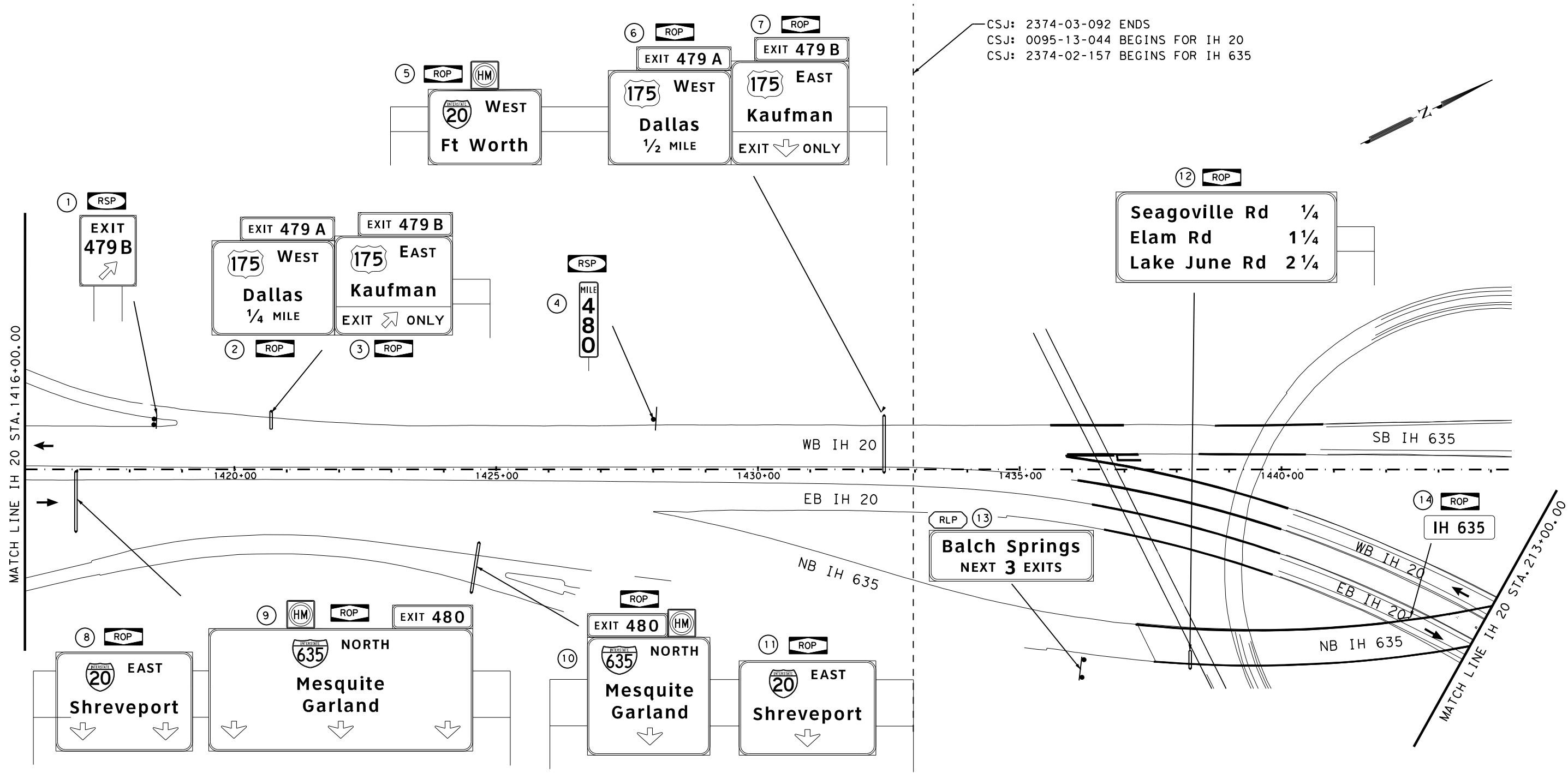

CSJ: 2374-03-092 ENDS
 CSJ: 0095-13-044 BEGINS FOR IH 20
 CSJ: 2374-02-157 BEGINS FOR IH 635

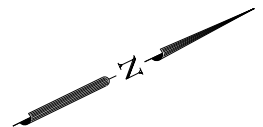

SIGNING LEGEND

- (E) EXISTING SIGN TO REMAIN
 - (3) SIGN TO BE INSTALLED
 - RSA REMOVE SMALL SIGN ASSEMBLY
 - RLA-1 REMOVE LARGE GROUND ASSEMBLY
 - RSP REPLACE SMALL SIGN PANEL
 - RLP REPLACE LARGE SIGN PANEL
 - ROP REPLACE OVERHEAD PANEL
 - ROS-1 REMOVE OVERHEAD STRUCTURE
-
- * REMOVAL ITEMS THIS SHEET
 - (EA) SMALL SIGNS ASSEMBLY
 - (EA) OVERHEAD SIGNS
 - (EA) LARGE SIGNS ASSEMBLY
 - (EA) WALKWAY
-
- * Removal Quantities are Approximate and Contractor Will be Paid For Actual Work Performed

INSTALL PROPOSED SIGNS
 1 FT TO 2 FT BEHIND EXISTING
 SIGN LOCATION,
 UNLESS OTHERWISE NOTED.

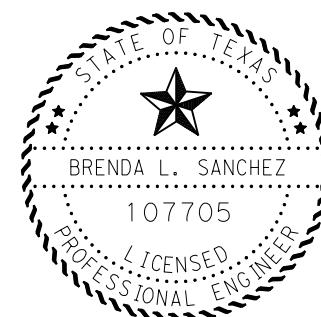

Brenda L Sanchez, P.E. 03/20/23
 Signature of Registrar & Date

Texas Department of Transportation
 ©2023

**SIGNING LAYOUT
 IH 20**

SCALE: 1"=200' SHEET 48 OF 121

DESIGN/CK BLS	FED. RD. DIV. NO. 6	STATE PROJECT NO. (SEE TITLE SHEET)		HIGHWAY NO. IH 20
CHECK BLS	STATE	DISTRICT DAL	COUNTY VARIOUS	SHEET NO. 152
CHECK MA	CONTROL 0095	SECTION 14	JOB 033, ETC	
CHECK BA				

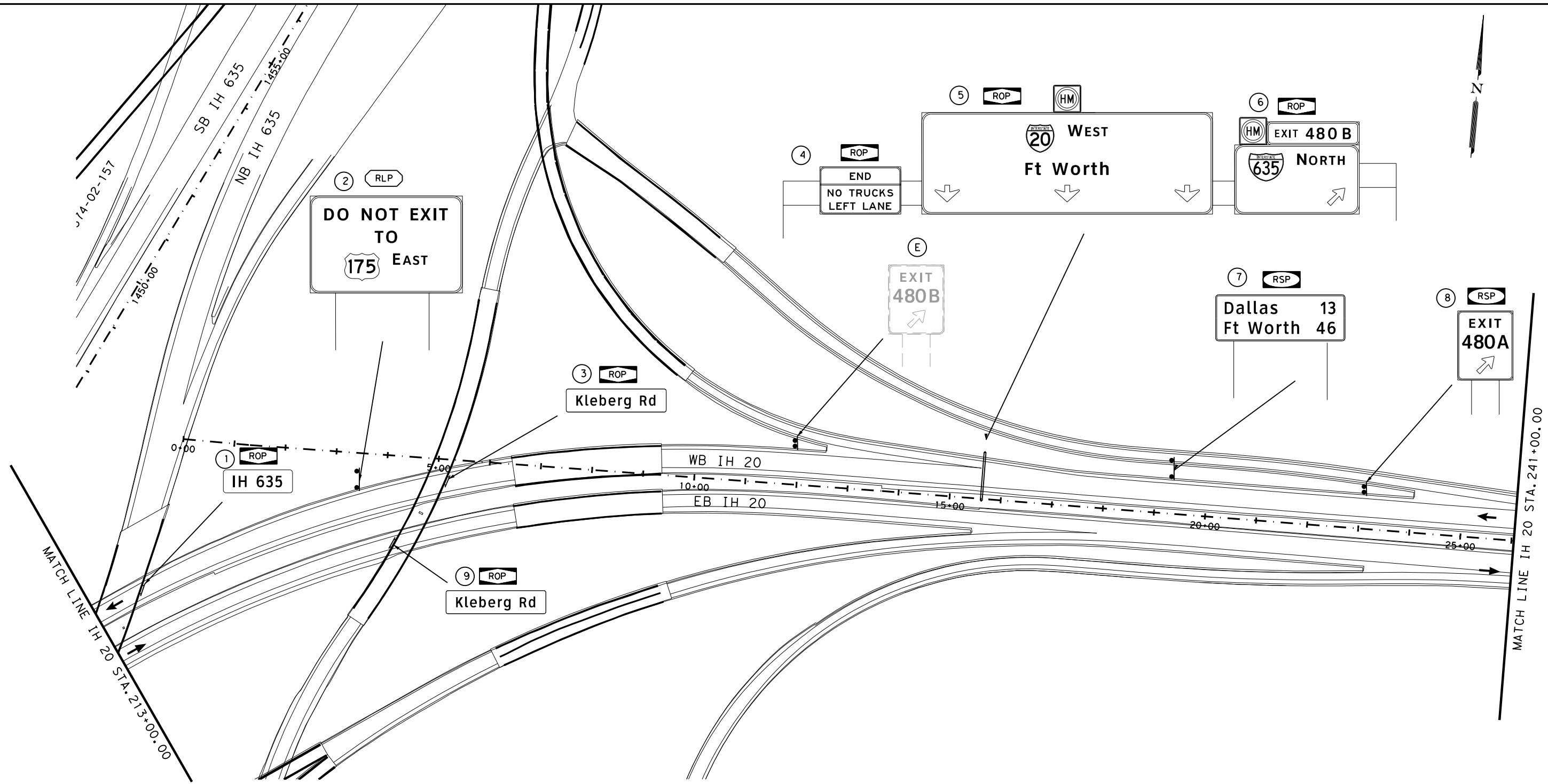

SIGNING LEGEND

- (E) EXISTING SIGN TO REMAIN
 - (3) SIGN TO BE INSTALLED
 - RSA REMOVE SMALL SIGN ASSEMBLY
 - RLA-1 REMOVE LARGE GROUND ASSEMBLY
 - RSP REPLACE SMALL SIGN PANEL
 - RLP REPLACE LARGE SIGN PANEL
 - ROP REPLACE OVERHEAD PANEL
 - ROS-1 REMOVE OVERHEAD STRUCTURE
-
- * REMOVAL ITEMS THIS SHEET
 - (EA) SMALL SIGNS ASSEMBLY
 - (EA) OVERHEAD SIGNS
 - (EA) LARGE SIGNS ASSEMBLY
 - (EA) WALKWAY
 - * Removal Quantities are Approximate and Contractor Will be Paid For Actual Work Performed

INSTALL PROPOSED SIGNS
1 FT TO 2 FT BEHIND EXISTING
SIGN LOCATION,
UNLESS OTHERWISE NOTED.

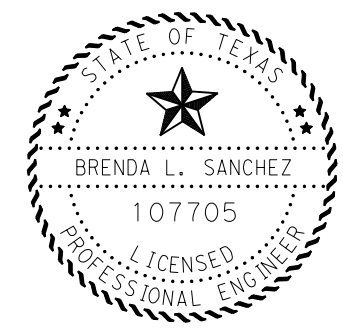

Brenda L. Sanchez, P.E. 03/20/23
Signature of Registrant & Date

Texas Department of Transportation
© 2023

**SIGNING LAYOUT
IH 20**

SCALE: 1"=200' SHEET 49 OF 121

DESIGN/CK BLS	FED. RD. DIV. NO. 6	STATE PROJECT NO. (SEE TITLE SHEET)		HIGHWAY NO. IH 20
CHECK BLS	STATE	DISTRICT DAL	COUNTY VARIOUS	SHEET NO. 153
CHECK MA	TEXAS	SECTION 033, ETC	JOB	
CHECK BA	CONTROL 0095	SECTION 14	JOB	

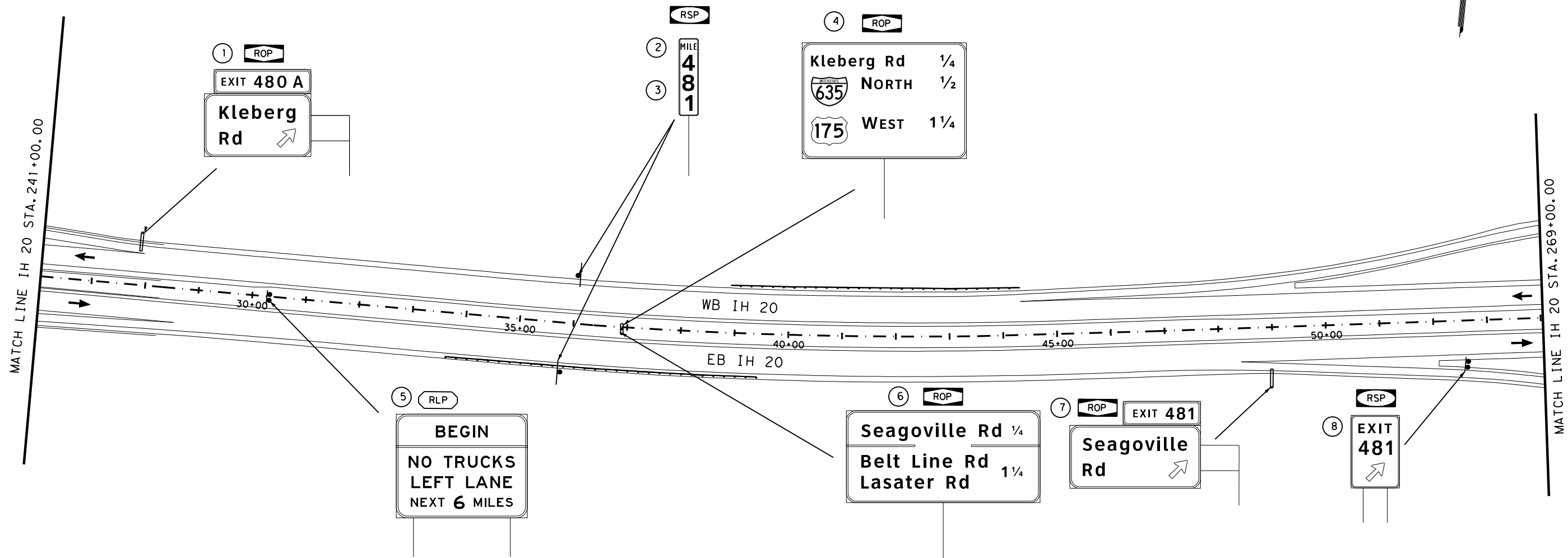

SIGNING LEGEND

- (E) EXISTING SIGN TO REMAIN
- (3) SIGN TO BE INSTALLED
- RSA REMOVE SMALL SIGN ASSEMBLY
- RLA-1 REMOVE LARGE GROUND ASSEMBLY
- RSP REPLACE SMALL SIGN PANEL
- RLP REPLACE LARGE SIGN PANEL
- ROP REPLACE OVERHEAD PANEL
- ROS-1 REMOVE OVERHEAD STRUCTURE

- * REMOVAL ITEMS THIS SHEET
- (EA) SMALL SIGNS ASSEMBLY
- (EA) OVERHEAD SIGNS
- (EA) LARGE SIGNS ASSEMBLY
- (EA) WALKWAY
- * Removal Quantities are Approximate and Contractor Will be Paid For Actual Work Performed

INSTALL PROPOSED SIGNS
1 FT TO 2 FT BEHIND EXISTING
SIGN LOCATION,
UNLESS OTHERWISE NOTED.

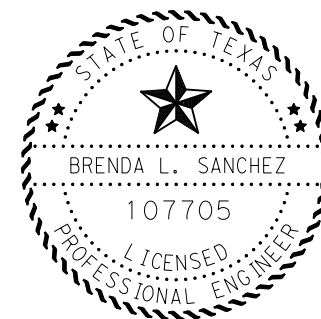

Brenda L. Sanchez, P.E. 03/20/23
Signature of Registrant & Date

© 2023

SIGNING LAYOUT IH 20

SCALE: 1"=200' SHEET 50 OF 121

DESIGN/CK BLS	FED. RD. DIV. NO. 6	STATE PROJECT NO. (SEE TITLE SHEET)		HIGHWAY NO. IH 20
CHECK BLS	STATE	DISTRICT	COUNTY	SHEET NO.
CHECK MA	TEXAS	DAL	VARIOUS	154
CHECK BA	CONTROL	SECTION	JOB	
	0095	14	033, ETC	

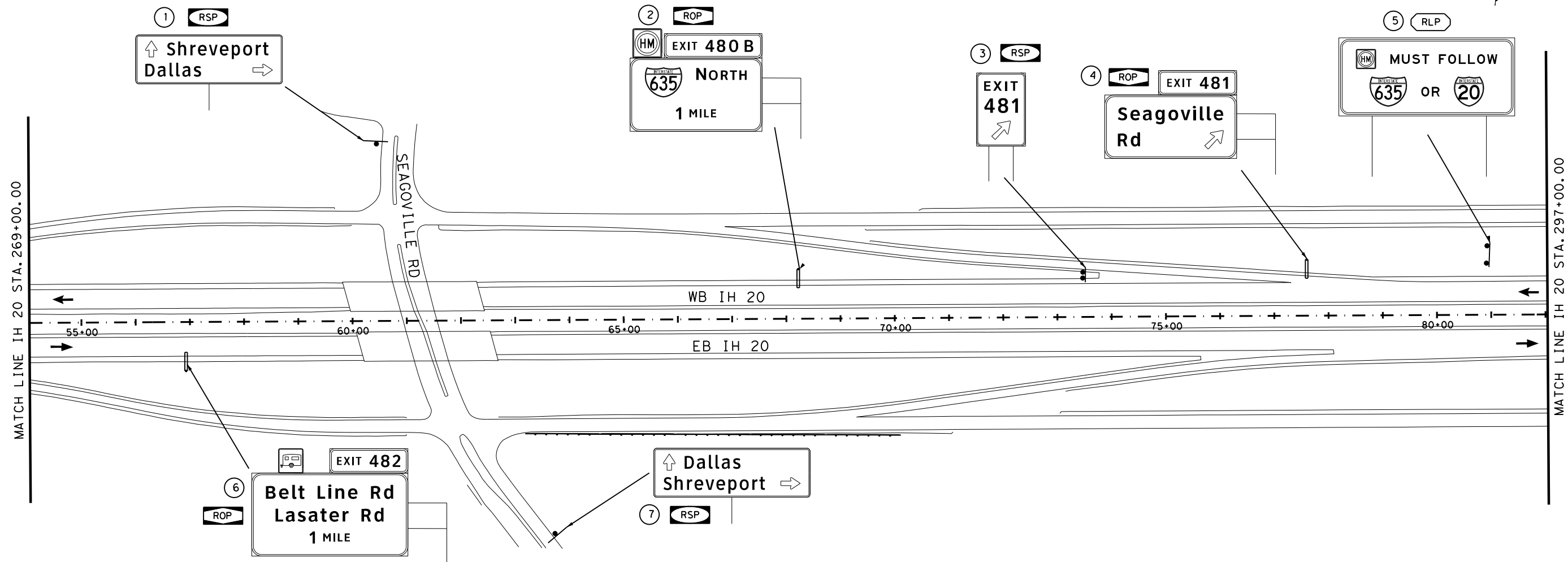

SIGNING LEGEND

- (E) EXISTING SIGN TO REMAIN
 - (3) SIGN TO BE INSTALLED
 - RSA REMOVE SMALL SIGN ASSEMBLY
 - RLA-1 REMOVE LARGE GROUND ASSEMBLY
 - RSP REPLACE SMALL SIGN PANEL
 - RLP REPLACE LARGE SIGN PANEL
 - ROP REPLACE OVERHEAD PANEL
 - ROS-1 REMOVE OVERHEAD STRUCTURE
-
- * REMOVAL ITEMS THIS SHEET
 - (EA) SMALL SIGNS ASSEMBLY
 - (EA) OVERHEAD SIGNS
 - (EA) LARGE SIGNS ASSEMBLY
 - (EA) WALKWAY
 - * Removal Quantities are Approximate and Contractor Will be Paid For Actual Work Performed

INSTALL PROPOSED SIGNS
1 FT TO 2 FT BEHIND EXISTING
SIGN LOCATION,
UNLESS OTHERWISE NOTED.

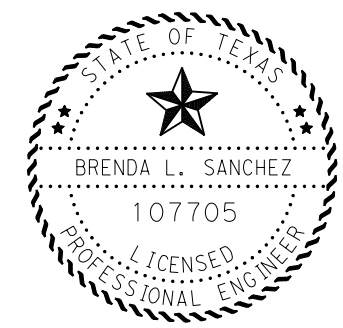

Brenda L. Sanchez, P.E. 03/20/23
Signature of Registrant & Date

Texas Department of Transportation
© 2023

**SIGNING LAYOUT
IH 20**

SCALE: 1"=200' SHEET 51 OF 121

DESIGN/CK BLS	FED. RD. DIV. NO. 6	STATE PROJECT NO. (SEE TITLE SHEET)		HIGHWAY NO. IH 20
CHECK BLS	STATE	DISTRICT DAL	COUNTY VARIOUS	SHEET NO. 155
CHECK MA	CONTROL	SECTION	JOB	
CHECK BA	0095	14	033, ETC	

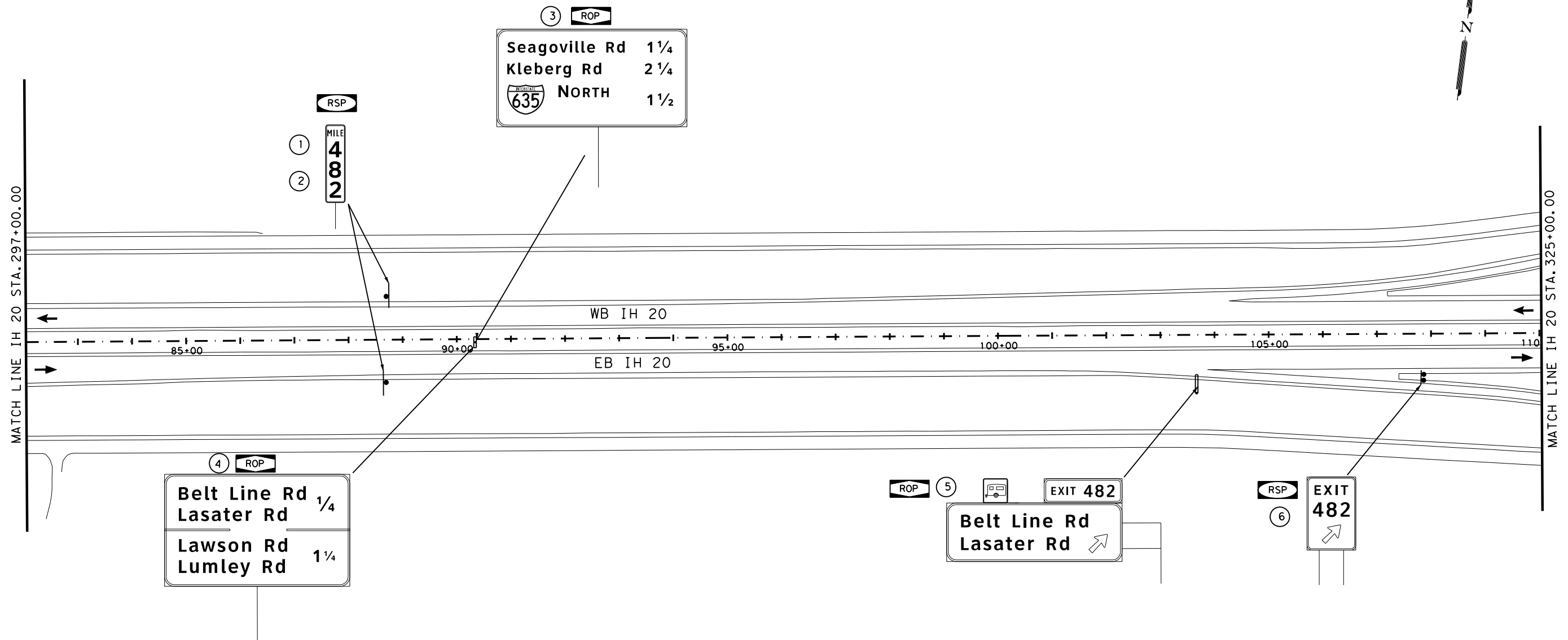

SIGNING LEGEND

- (E) EXISTING SIGN TO REMAIN
 - (3) SIGN TO BE INSTALLED
 - RSA REMOVE SMALL SIGN ASSEMBLY
 - RLA-1 REMOVE LARGE GROUND ASSEMBLY
 - RSP REPLACE SMALL SIGN PANEL
 - RLP REPLACE LARGE SIGN PANEL
 - ROP REPLACE OVERHEAD PANEL
 - ROS-1 REMOVE OVERHEAD STRUCTURE
-
- * REMOVAL ITEMS THIS SHEET
 - (EA) SMALL SIGNS ASSEMBLY
 - (EA) OVERHEAD SIGNS
 - (EA) LARGE SIGNS ASSEMBLY
 - (EA) WALKWAY
-
- * Removal Quantities are Approximate and Contractor Will be Paid For Actual Work Performed

INSTALL PROPOSED SIGNS
1 FT TO 2 FT BEHIND EXISTING
SIGN LOCATION,
UNLESS OTHERWISE NOTED.

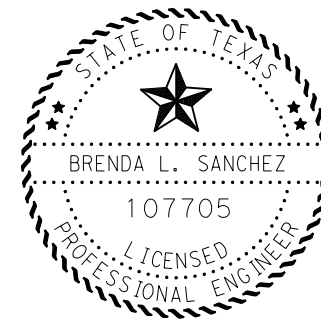

Brenda L. Sanchez, P.E. 03/20/23
Signature of Registrant & Date

Texas Department of Transportation
© 2023

**SIGNING LAYOUT
IH 20**

SCALE: 1"=200' SHEET 52 OF 121

DESIGN/CK BLS	FED. RD. DIV. NO. 6	STATE PROJECT NO. (SEE TITLE SHEET)		HIGHWAY NO. IH 20
CHECK BLS	STATE	DISTRICT DAL	COUNTY VARIOUS	SHEET NO. 156
CHECK MA	TEXAS	SECTION 033, ETC	JOB	
CHECK BA	CONTROL 0095	SECTION 14	JOB	

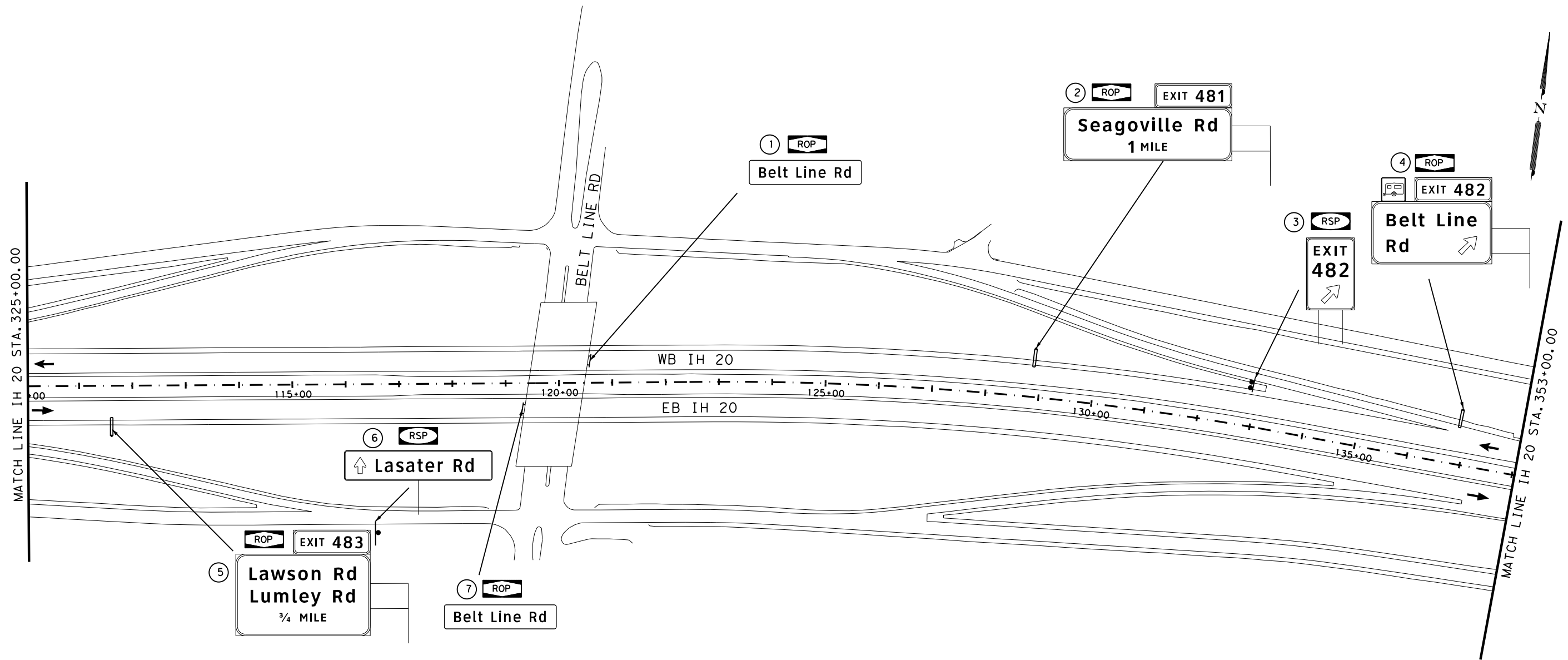

SIGNING LEGEND

- (E) EXISTING SIGN TO REMAIN
 - (3) SIGN TO BE INSTALLED
 - RSA REMOVE SMALL SIGN ASSEMBLY
 - RLA-1 REMOVE LARGE GROUND ASSEMBLY
 - RSP REPLACE SMALL SIGN PANEL
 - RLP REPLACE LARGE SIGN PANEL
 - ROP REPLACE OVERHEAD PANEL
 - ROS-1 REMOVE OVERHEAD STRUCTURE
-
- * REMOVAL ITEMS THIS SHEET
 - (EA) SMALL SIGNS ASSEMBLY
 - (EA) OVERHEAD SIGNS
 - (EA) LARGE SIGNS ASSEMBLY
 - (EA) WALKWAY
-
- * Removal Quantities are Approximate and Contractor Will be Paid For Actual Work Performed

INSTALL PROPOSED SIGNS
1 FT TO 2 FT BEHIND EXISTING
SIGN LOCATION,
UNLESS OTHERWISE NOTED.

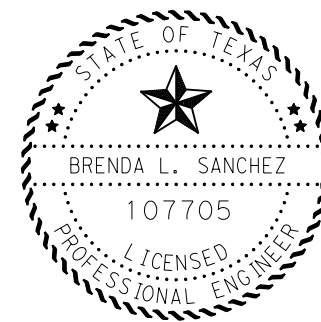

Brenda L. Sanchez, P.E. 03/20/23
Signature of Registrant & Date

Texas Department of Transportation
© 2023

**SIGNING LAYOUT
IH 20**

SCALE: 1"=200' SHEET 53 OF 121

DESIGN/CK BLS	FED. RD. DIV. NO. 6	STATE PROJECT NO. (SEE TITLE SHEET)		HIGHWAY NO. IH 20
CHECK BLS	STATE	DISTRICT	COUNTY	SHEET NO.
CHECK MA	TEXAS	DAL	VARIOUS	157
CHECK BA	CONTROL	SECTION	JOB	
	0095	14	033, ETC	

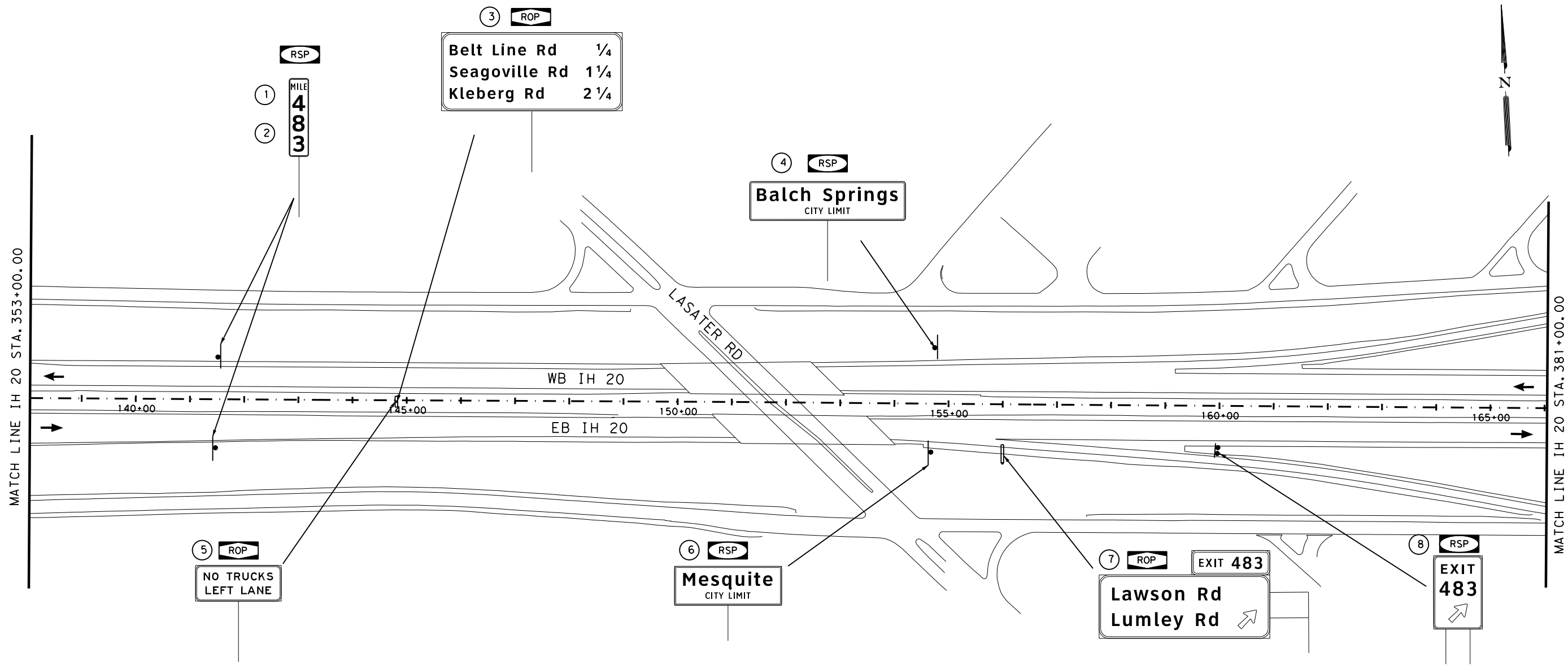

SIGNING LEGEND

- (E) EXISTING SIGN TO REMAIN
- (3) SIGN TO BE INSTALLED
- RSA REMOVE SMALL SIGN ASSEMBLY
- RLA-1 REMOVE LARGE GROUND ASSEMBLY
- RSP REPLACE SMALL SIGN PANEL
- RLP REPLACE LARGE SIGN PANEL
- ROP REPLACE OVERHEAD PANEL
- ROS-1 REMOVE OVERHEAD STRUCTURE

- * REMOVAL ITEMS THIS SHEET
- (EA) SMALL SIGNS ASSEMBLY
 - (EA) OVERHEAD SIGNS
 - (EA) LARGE SIGNS ASSEMBLY
 - (EA) WALKWAY
- * Removal Quantities are Approximate and Contractor Will be Paid For Actual Work Performed

INSTALL PROPOSED SIGNS
1 FT TO 2 FT BEHIND EXISTING
SIGN LOCATION,
UNLESS OTHERWISE NOTED.



Brenda L Sanchez, P.E. 03/20/23
Signature of Registrar & Date

Texas Department of Transportation
© 2023

**SIGNING LAYOUT
IH 20**

SCALE: 1"=200' SHEET 54 OF 121

DESIGN/CK BLS	FED. RD. DIV. NO. 6	STATE PROJECT NO. (SEE TITLE SHEET)		HIGHWAY NO. IH 20
CHECK BLS	STATE	DISTRICT	COUNTY	SHEET NO.
CHECK MA	TEXAS	DAL	VARIOUS	158
CHECK BA	CONTROL	SECTION	JOB	
	0095	14	033, ETC	

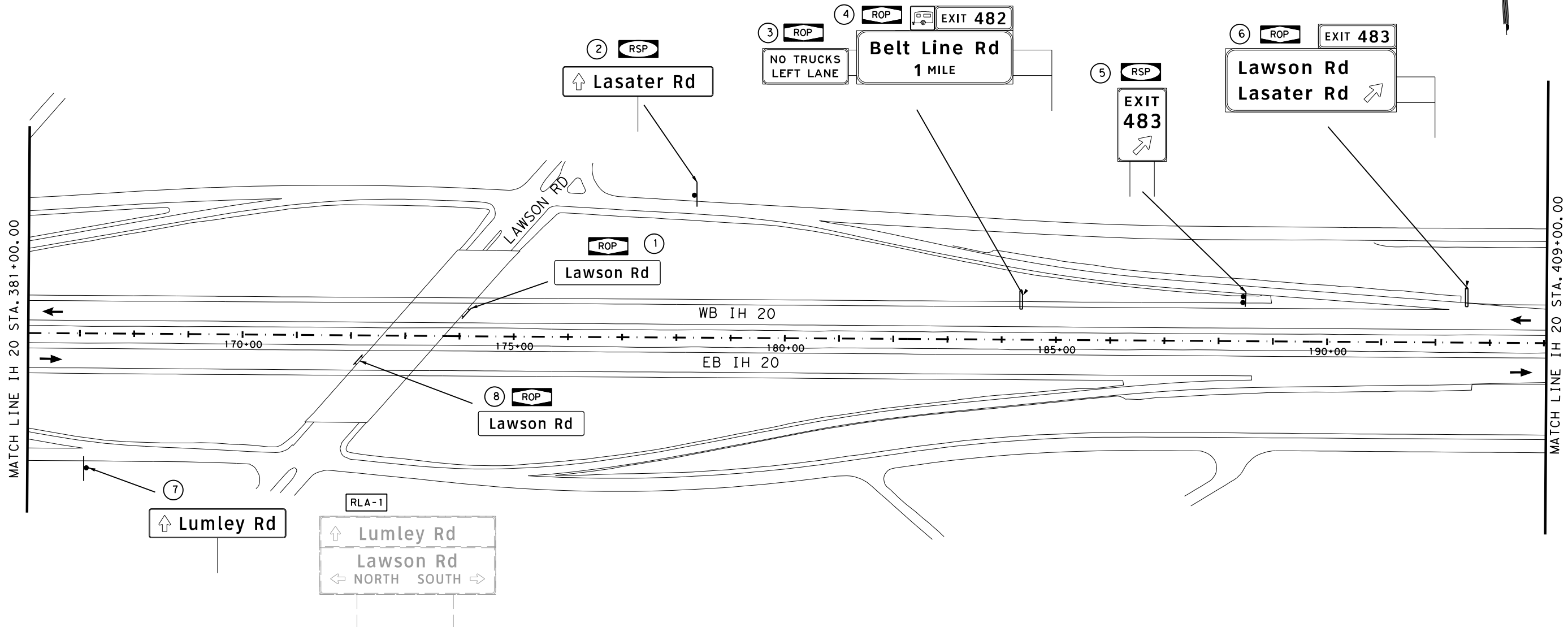

SIGNING LEGEND

- (E) EXISTING SIGN TO REMAIN
 - (3) SIGN TO BE INSTALLED
 - RSA REMOVE SMALL SIGN ASSEMBLY
 - RLA-1 REMOVE LARGE GROUND ASSEMBLY
 - RSP REPLACE SMALL SIGN PANEL
 - RLP REPLACE LARGE SIGN PANEL
 - ROP REPLACE OVERHEAD PANEL
 - ROS-1 REMOVE OVERHEAD STRUCTURE
-
- * REMOVAL ITEMS THIS SHEET
 - (EA) SMALL SIGNS ASSEMBLY
 - (EA) OVERHEAD SIGNS
 - 1 (EA) LARGE SIGNS ASSEMBLY
 - (EA) WALKWAY
- * Removal Quantities are Approximate and Contractor Will be Paid For Actual Work Performed

INSTALL PROPOSED SIGNS
1 FT TO 2 FT BEHIND EXISTING
SIGN LOCATION,
UNLESS OTHERWISE NOTED.



Brenda L Sanchez, P.E. 03/20/23
Signature of Registrant & Date



**SIGNING LAYOUT
IH 20**

SCALE: 1"=200' SHEET 55 OF 121

DESIGN/CK BLS	FED. RD. DIV. NO. 6	STATE PROJECT NO. (SEE TITLE SHEET)		HIGHWAY NO. IH 20
CHECK BLS	STATE	DISTRICT	COUNTY	SHEET NO.
CHECK MA	TEXAS	DAL	VARIOUS	159
CHECK BA	CONTROL	SECTION	JOB	
	0095	14	033, ETC	

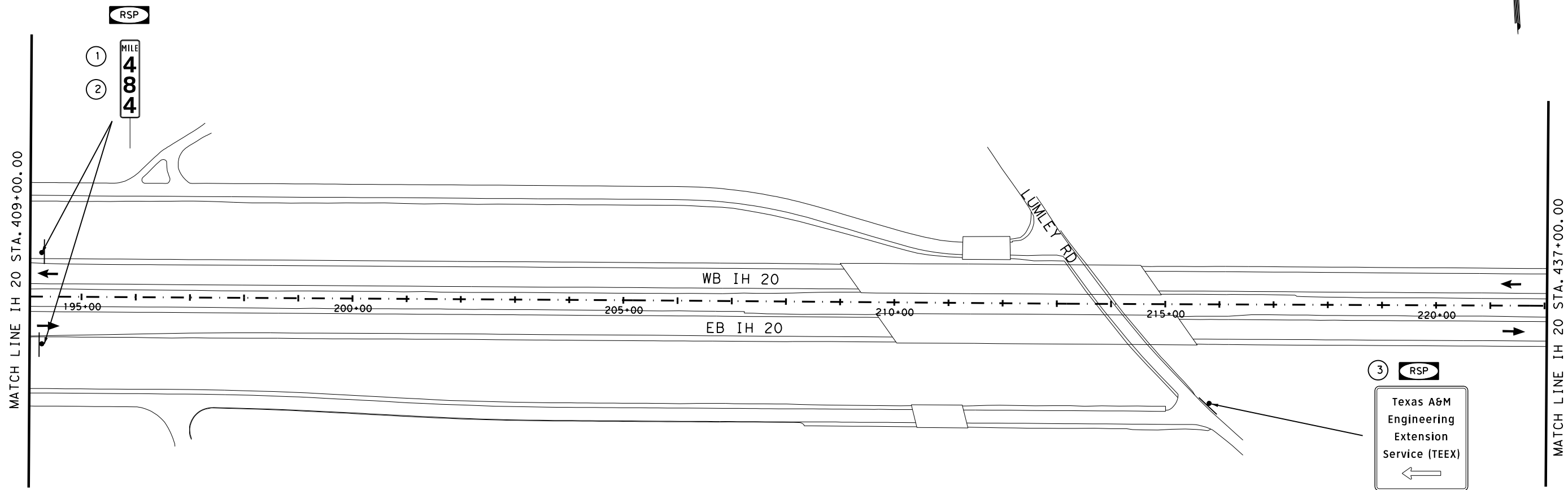

SIGNING LEGEND

- (E) EXISTING SIGN TO REMAIN
- (3) SIGN TO BE INSTALLED
- RSA REMOVE SMALL SIGN ASSEMBLY
- RLA-1 REMOVE LARGE GROUND ASSEMBLY
- RSP REPLACE SMALL SIGN PANEL
- RLP REPLACE LARGE SIGN PANEL
- ROP REPLACE OVERHEAD PANEL
- ROS-1 REMOVE OVERHEAD STRUCTURE

- * REMOVAL ITEMS THIS SHEET
- (EA) SMALL SIGNS ASSEMBLY
 - (EA) OVERHEAD SIGNS
 - (EA) LARGE SIGNS ASSEMBLY
 - (EA) WALKWAY
- * Removal Quantities are Approximate and Contractor Will be Paid For Actual Work Performed

INSTALL PROPOSED SIGNS
1 FT TO 2 FT BEHIND EXISTING
SIGN LOCATION,
UNLESS OTHERWISE NOTED.

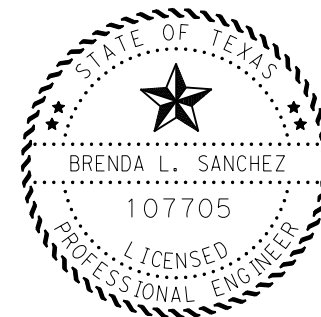

Brenda L Sanchez, P.E. 03/20/23
Signature of Registrant & Date

Texas Department of Transportation
© 2023

**SIGNING LAYOUT
IH 20**

SCALE: 1"=200' SHEET 56 OF 121

DESIGN/CK BLS	FED. RD. DIV. NO. 6	STATE PROJECT NO. (SEE TITLE SHEET)		HIGHWAY NO. IH 20
CHECK BLS	STATE	DISTRICT DAL	COUNTY VARIOUS	SHEET NO. 160
CHECK MA	TEXAS	SECTION CONTROL	JOB 033, ETC	
CHECK BA	0095	14		

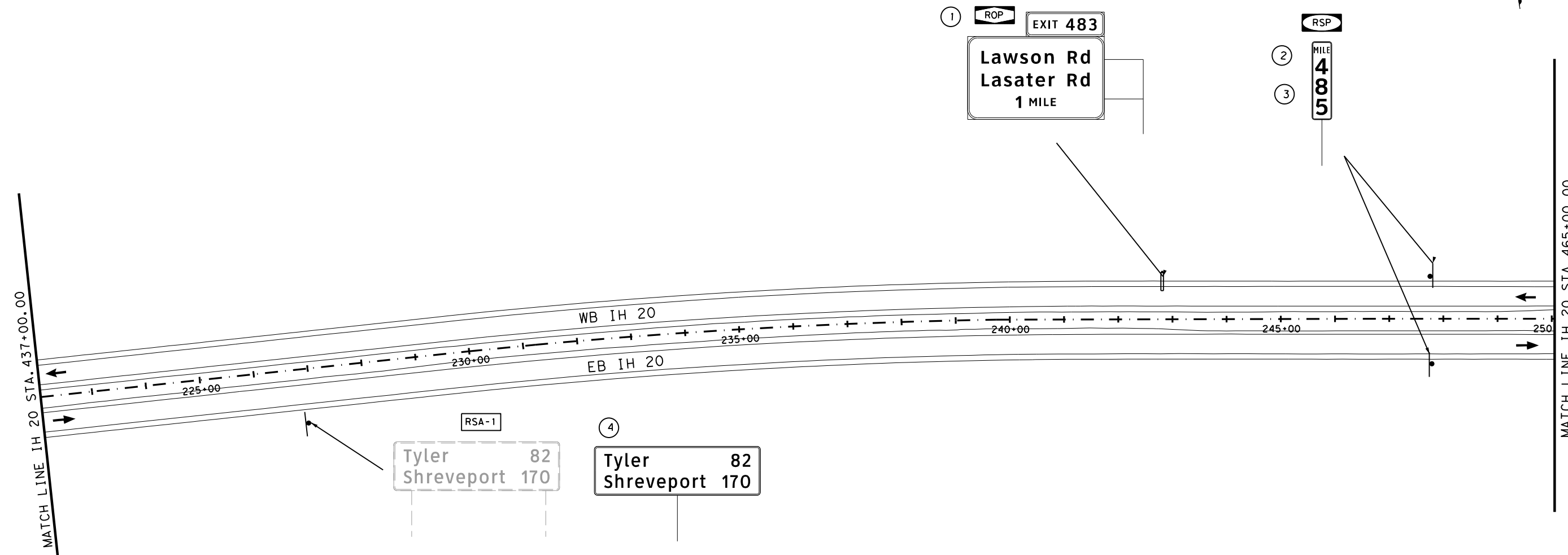

SIGNING LEGEND

- (E) EXISTING SIGN TO REMAIN
- (3) SIGN TO BE INSTALLED
- RSA REMOVE SMALL SIGN ASSEMBLY
- RLA-1 REMOVE LARGE GROUND ASSEMBLY
- RSP REPLACE SMALL SIGN PANEL
- RLP REPLACE LARGE SIGN PANEL
- ROP REPLACE OVERHEAD PANEL
- ROS-1 REMOVE OVERHEAD STRUCTURE

- * REMOVAL ITEMS THIS SHEET
- 1 (EA) SMALL SIGNS ASSEMBLY
 - (EA) OVERHEAD SIGNS
 - (EA) LARGE SIGNS ASSEMBLY
 - (EA) WALKWAY
- * Removal Quantities are Approximate and Contractor Will be Paid For Actual Work Performed

INSTALL PROPOSED SIGNS
1 FT TO 2 FT BEHIND EXISTING
SIGN LOCATION,
UNLESS OTHERWISE NOTED.

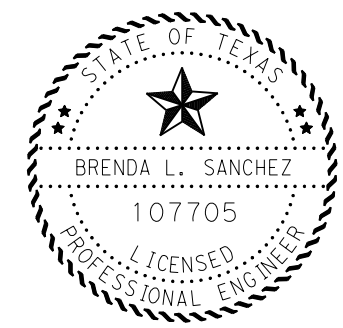

Brenda L. Sanchez, P.E. 03/20/23
Signature of Registrar & Date



**SIGNING LAYOUT
IH 20**

SCALE: 1"=200' SHEET 57 OF 121

DESIGN/CK BLS	FED. RD. DIV. NO. 6	STATE PROJECT NO. (SEE TITLE SHEET)		HIGHWAY NO. IH 20
CHECK BLS	STATE	DISTRICT DAL	COUNTY VARIOUS	SHEET NO. 161
CHECK MA	TEXAS	SECTION 14	JOB 033, ETC	
CHECK BA	0095			

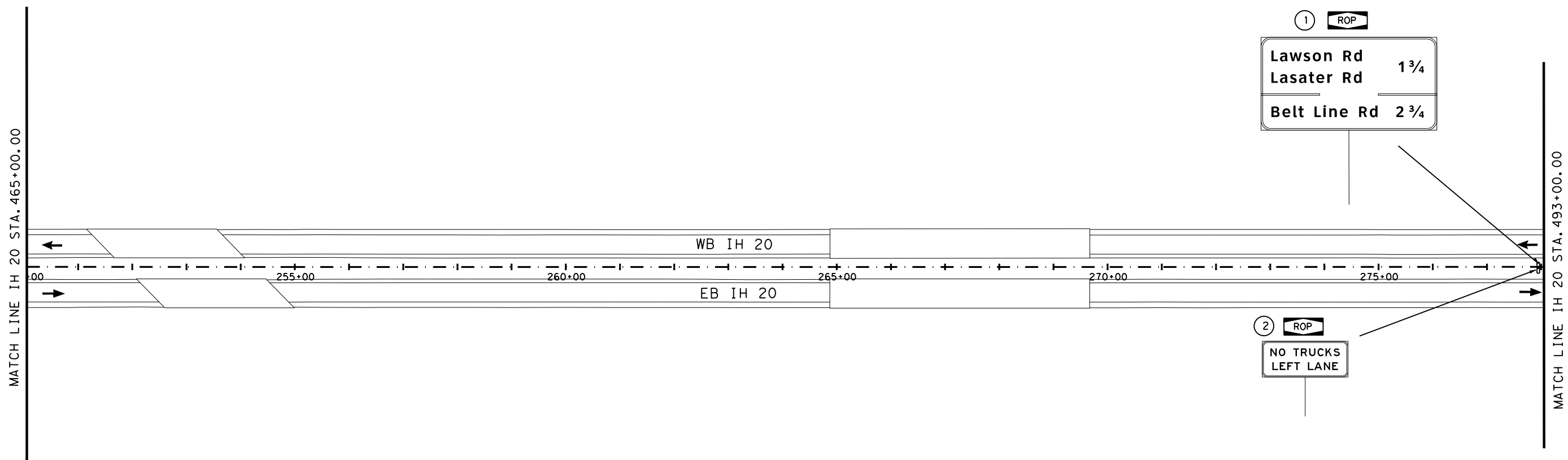

SIGNING LEGEND

- (E) EXISTING SIGN TO REMAIN
- (3) SIGN TO BE INSTALLED
- RSA REMOVE SMALL SIGN ASSEMBLY
- RLA-1 REMOVE LARGE GROUND ASSEMBLY
- RSP REPLACE SMALL SIGN PANEL
- RLP REPLACE LARGE SIGN PANEL
- ROP REPLACE OVERHEAD PANEL
- ROS-1 REMOVE OVERHEAD STRUCTURE

- * REMOVAL ITEMS THIS SHEET
- (EA) SMALL SIGNS ASSEMBLY
 - (EA) OVERHEAD SIGNS
 - (EA) LARGE SIGNS ASSEMBLY
 - (EA) WALKWAY
- * Removal Quantities are Approximate and Contractor Will be Paid For Actual Work Performed

INSTALL PROPOSED SIGNS
1 FT TO 2 FT BEHIND EXISTING
SIGN LOCATION,
UNLESS OTHERWISE NOTED.



Brenda L. Sanchez, P.E. 03/20/23
Signature of Registrant & Date



**SIGNING LAYOUT
IH 20**

SCALE: 1"=200' SHEET 58 OF 121

DESIGN/CK BLS	FED. RD. DIV. NO. 6	STATE PROJECT NO. (SEE TITLE SHEET)		HIGHWAY NO. IH 20
CHECK BLS	STATE	DISTRICT DAL	COUNTY	SHEET NO. 162
CHECK MA	TEXAS	SECTION 14	JOB VARIOUS	
CHECK BA	CONTROL 0095			

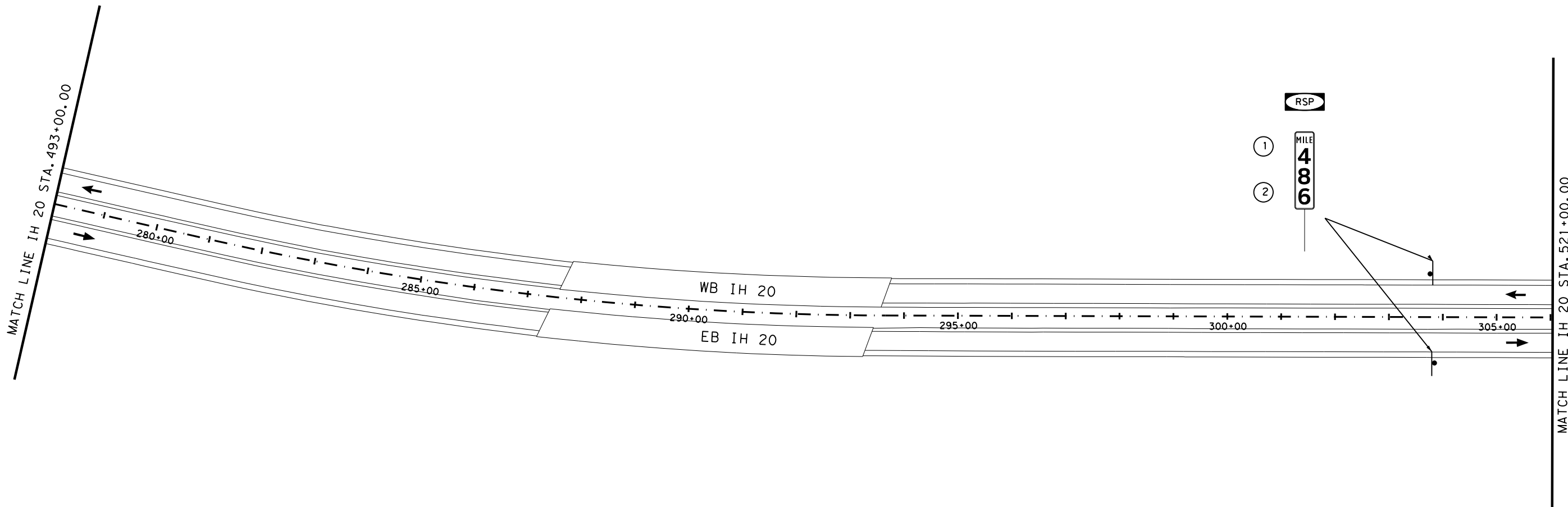

SIGNING LEGEND

- (E) EXISTING SIGN TO REMAIN
- (3) SIGN TO BE INSTALLED
- RSA REMOVE SMALL SIGN ASSEMBLY
- RLA-1 REMOVE LARGE GROUND ASSEMBLY
- RSP REPLACE SMALL SIGN PANEL
- RLP REPLACE LARGE SIGN PANEL
- ROP REPLACE OVERHEAD PANEL
- ROS-1 REMOVE OVERHEAD STRUCTURE

- * REMOVAL ITEMS THIS SHEET
- (EA) SMALL SIGNS ASSEMBLY
 - (EA) OVERHEAD SIGNS
 - (EA) LARGE SIGNS ASSEMBLY
 - (EA) WALKWAY
- * Removal Quantities are Approximate and Contractor Will be Paid For Actual Work Performed

INSTALL PROPOSED SIGNS
1 FT TO 2 FT BEHIND EXISTING
SIGN LOCATION,
UNLESS OTHERWISE NOTED.

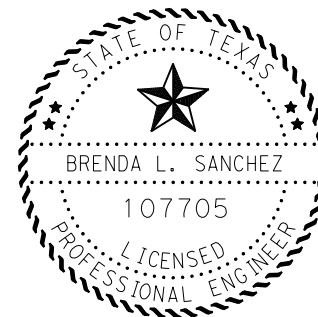

Brenda L. Sanchez, P.E. 03/20/23
Signature of Registrant & Date



**SIGNING LAYOUT
IH 20**

SCALE: 1"=200' SHEET 59 OF 121

DESIGN/CHECK	FED. RD. DIV. NO.	STATE PROJECT NO.		HIGHWAY NO.
BLS	6	(SEE TITLE SHEET)		IH 20
CHECK	STATE	DISTRICT	COUNTY	SHEET NO.
BLS	TEXAS	DAL	VARIOUS	163
CHECK	CONTROL	SECTION	JOB	
BA	0095	14	033, ETC	

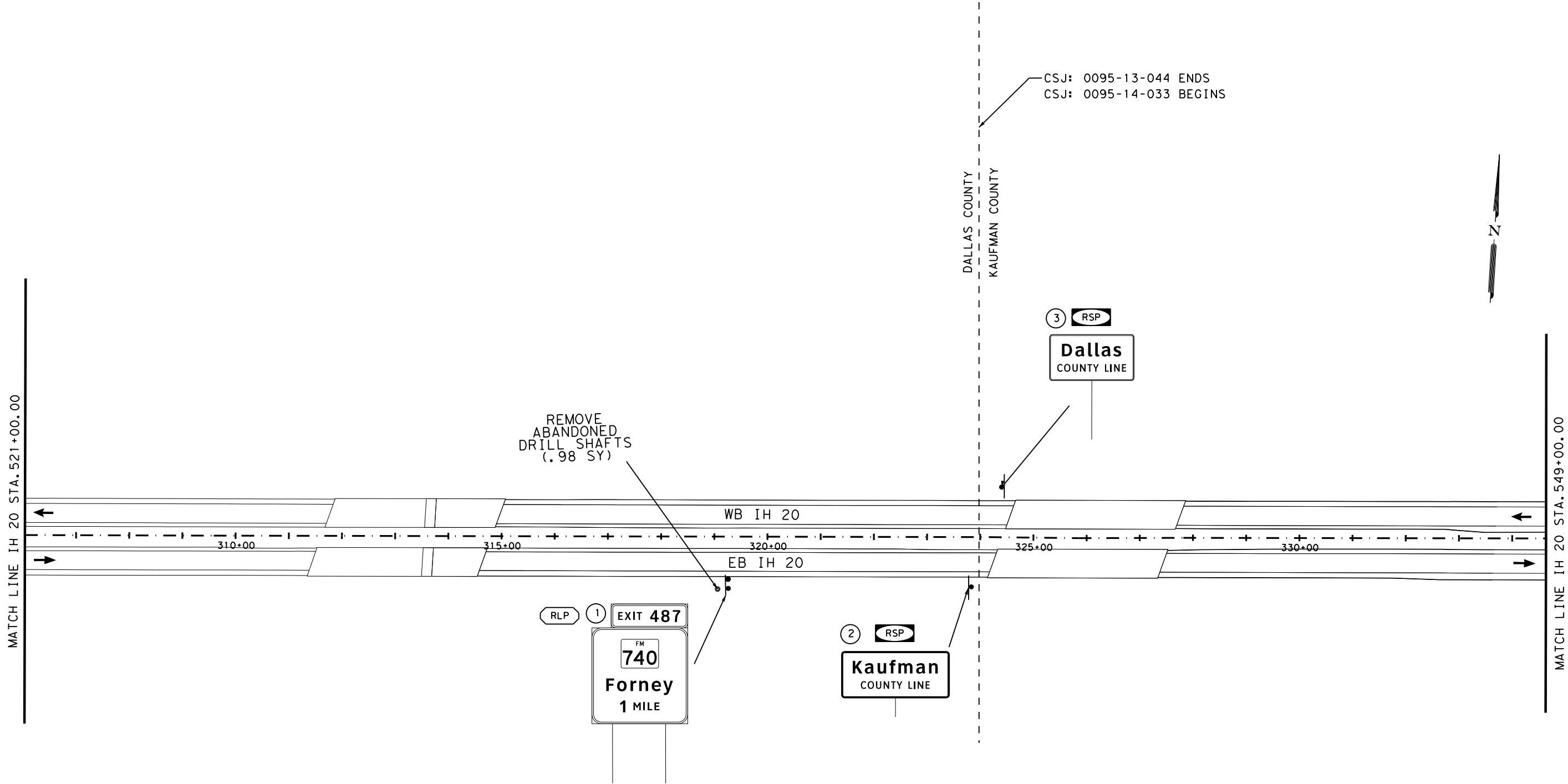

SIGNING LEGEND

- (E) EXISTING SIGN TO REMAIN
- (3) SIGN TO BE INSTALLED
- RSA REMOVE SMALL SIGN ASSEMBLY
- RLA-1 REMOVE LARGE GROUND ASSEMBLY
- RSP REPLACE SMALL SIGN PANEL
- RLP REPLACE LARGE SIGN PANEL
- ROP REPLACE OVERHEAD PANEL
- ROS-1 REMOVE OVERHEAD STRUCTURE

- * REMOVAL ITEMS THIS SHEET
- (EA) SMALL SIGNS ASSEMBLY
 - (EA) OVERHEAD SIGNS
 - (EA) LARGE SIGNS ASSEMBLY
 - (EA) WALKWAY
- * Removal Quantities are Approximate and Contractor Will be Paid For Actual Work Performed

INSTALL PROPOSED SIGNS
1 FT TO 2 FT BEHIND EXISTING
SIGN LOCATION,
UNLESS OTHERWISE NOTED.



Brenda L Sanchez, P.E. 03/20/23
Signature of Registrar & Date



Texas Department of Transportation
© 2023

**SIGNING LAYOUT
IH 20**

SCALE: 1"=200' SHEET 60 OF 121

DESIGN/CK BLS	FED. RD. DIV. NO. 6	STATE PROJECT NO. (SEE TITLE SHEET)		HIGHWAY NO. IH 20
CHECK BLS	STATE	DISTRICT DAL	COUNTY VARIOUS	SHEET NO. 164
CHECK MA	CONTROL	SECTION	JOB	
CHECK BA	0095	14	033, ETC	

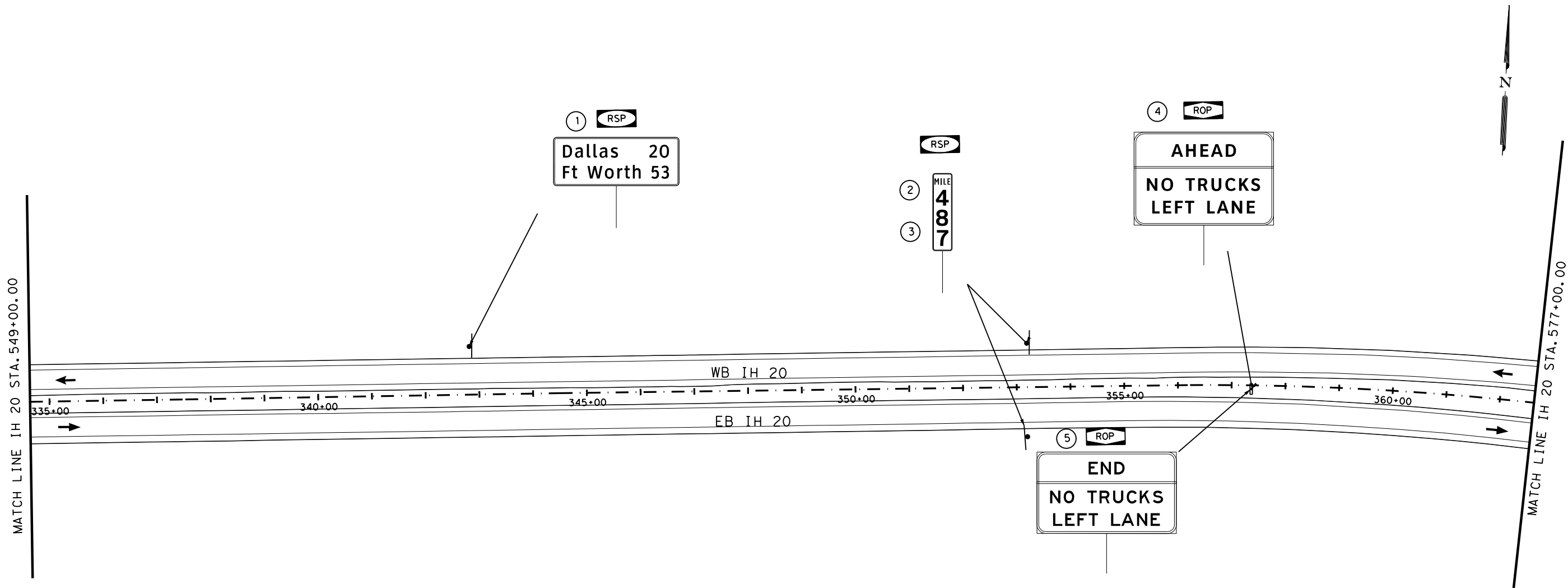

SIGNING LEGEND

- (E) EXISTING SIGN TO REMAIN
- (3) SIGN TO BE INSTALLED
- RSA REMOVE SMALL SIGN ASSEMBLY
- RLA-1 REMOVE LARGE GROUND ASSEMBLY
- RSP REPLACE SMALL SIGN PANEL
- RLP REPLACE LARGE SIGN PANEL
- ROP REPLACE OVERHEAD PANEL
- ROS-1 REMOVE OVERHEAD STRUCTURE

- * REMOVAL ITEMS THIS SHEET
- (EA) SMALL SIGNS ASSEMBLY
 - (EA) OVERHEAD SIGNS
 - (EA) LARGE SIGNS ASSEMBLY
 - (EA) WALKWAY
- * Removal Quantities are Approximate and Contractor Will be Paid For Actual Work Performed

INSTALL PROPOSED SIGNS
1 FT TO 2 FT BEHIND EXISTING
SIGN LOCATION,
UNLESS OTHERWISE NOTED.



Brenda L. Sanchez, P.E. 03/20/23
Signature of Registrar & Date

Texas Department of Transportation
© 2023

**SIGNING LAYOUT
IH 20**

SCALE: 1"=200' SHEET 61 OF 121

DESIGN/CK BLS	FED. RD. DIV. NO. 6	STATE PROJECT NO. (SEE TITLE SHEET)		HIGHWAY NO. IH 20
CHECK BLS	STATE	DISTRICT DAL	COUNTY VARIOUS	SHEET NO. 165
CHECK MA	TEXAS	SECTION 14	JOB 033, ETC	
CHECK BA	CONTROL 0095			

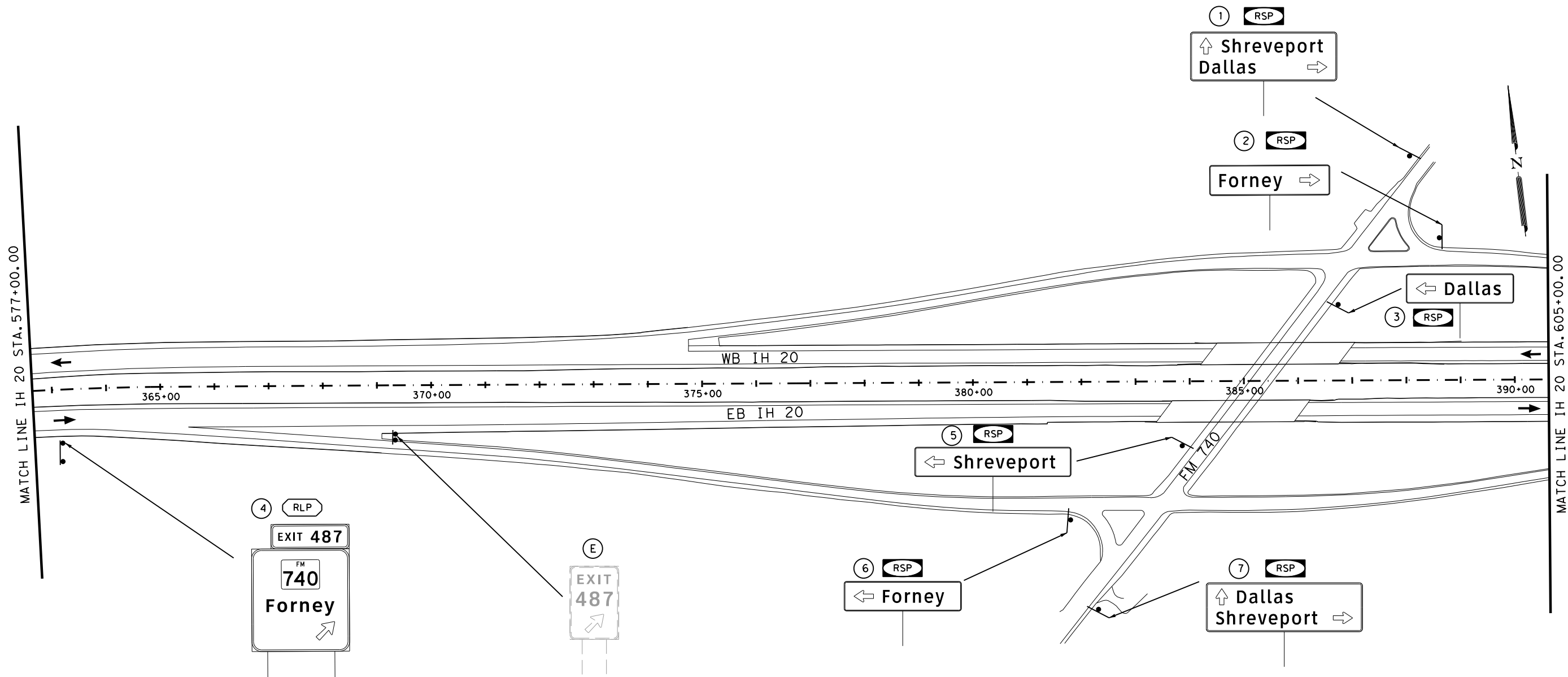

SIGNING LEGEND

- (E) EXISTING SIGN TO REMAIN
- (3) SIGN TO BE INSTALLED
- RSA REMOVE SMALL SIGN ASSEMBLY
- RLA-1 REMOVE LARGE GROUND ASSEMBLY
- RSP REPLACE SMALL SIGN PANEL
- RLP REPLACE LARGE SIGN PANEL
- ROP REPLACE OVERHEAD PANEL
- ROS-1 REMOVE OVERHEAD STRUCTURE

- * REMOVAL ITEMS THIS SHEET
- (EA) SMALL SIGNS ASSEMBLY
 - (EA) OVERHEAD SIGNS
 - (EA) LARGE SIGNS ASSEMBLY
 - (EA) WALKWAY
- * Removal Quantities are Approximate and Contractor Will be Paid For Actual Work Performed

INSTALL PROPOSED SIGNS
1 FT TO 2 FT BEHIND EXISTING
SIGN LOCATION,
UNLESS OTHERWISE NOTED.



Brenda L Sanchez, P.E. 03/20/23
Signature of Registrar & Date

Texas Department of Transportation
© 2023

**SIGNING LAYOUT
IH 20**

SCALE: 1"=200' SHEET 62 OF 121

DESIGN/CK BLS	FED. RD. DIV. NO. 6	STATE PROJECT NO. (SEE TITLE SHEET)		HIGHWAY NO. IH 20
CHECK BLS	STATE	DISTRICT DAL	COUNTY VARIOUS	SHEET NO. 166
CHECK MA	TEXAS	SECTION 14	JOB 033, ETC	
CHECK BA	0095			

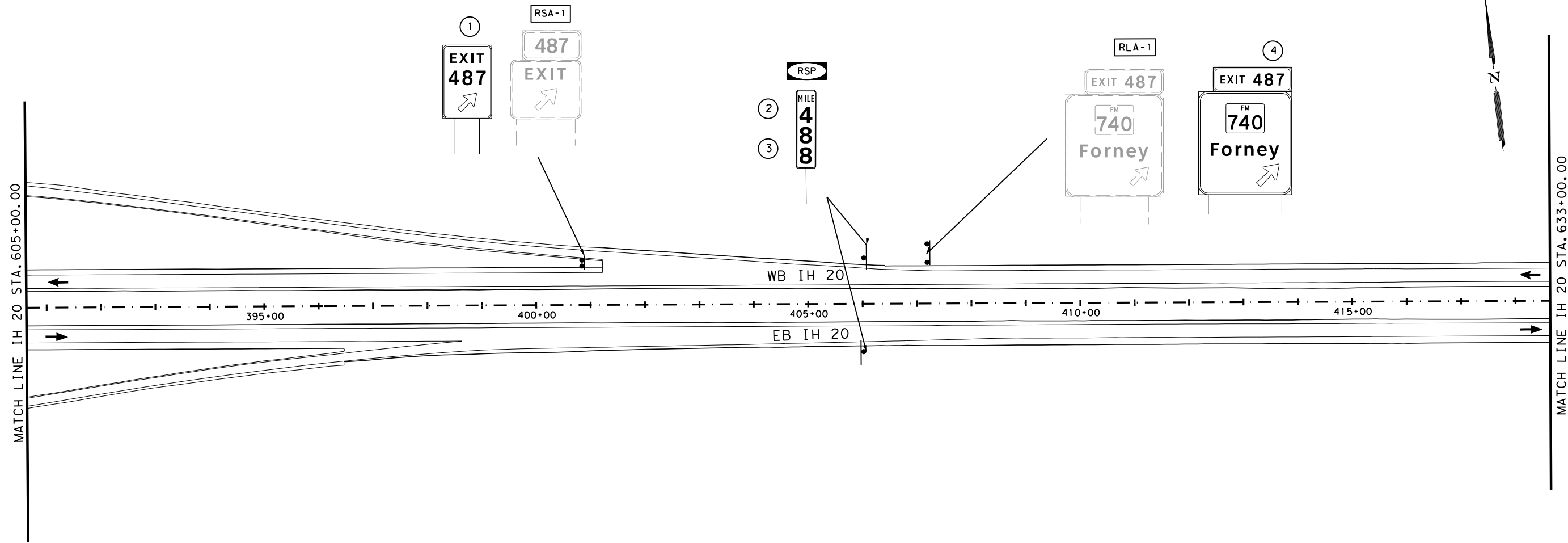

SIGNING LEGEND

- (E) EXISTING SIGN TO REMAIN
- (3) SIGN TO BE INSTALLED
- RSA REMOVE SMALL SIGN ASSEMBLY
- RLA-1 REMOVE LARGE GROUND ASSEMBLY
- RSP REPLACE SMALL SIGN PANEL
- RLP REPLACE LARGE SIGN PANEL
- ROP REPLACE OVERHEAD PANEL
- ROS-1 REMOVE OVERHEAD STRUCTURE

- * REMOVAL ITEMS THIS SHEET
- 1 (EA) SMALL SIGNS ASSEMBLY
 - 1 (EA) OVERHEAD SIGNS
 - 1 (EA) LARGE SIGNS ASSEMBLY
 - 1 (EA) WALKWAY
- * Removal Quantities are Approximate and Contractor Will be Paid For Actual Work Performed

INSTALL PROPOSED SIGNS
1 FT TO 2 FT BEHIND EXISTING
SIGN LOCATION,
UNLESS OTHERWISE NOTED.

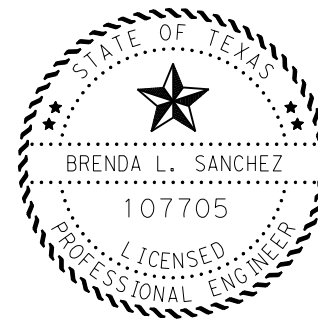

Brenda L. Sanchez, P.E. 03/20/23
Signature of Registrar & Date



**SIGNING LAYOUT
IH 20**

SCALE: 1"=200' SHEET 63 OF 121

DESIGN/CK BLS	FED. RD. DIV. NO. 6	STATE PROJECT NO. (SEE TITLE SHEET)		HIGHWAY NO. IH 20
CHECK BLS	STATE	DISTRICT DAL	COUNTY VARIOUS	SHEET NO. 167
CHECK MA	CONTROL	SECTION	JOB	
CHECK BA	0095	14	033, ETC	

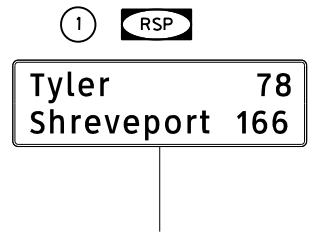
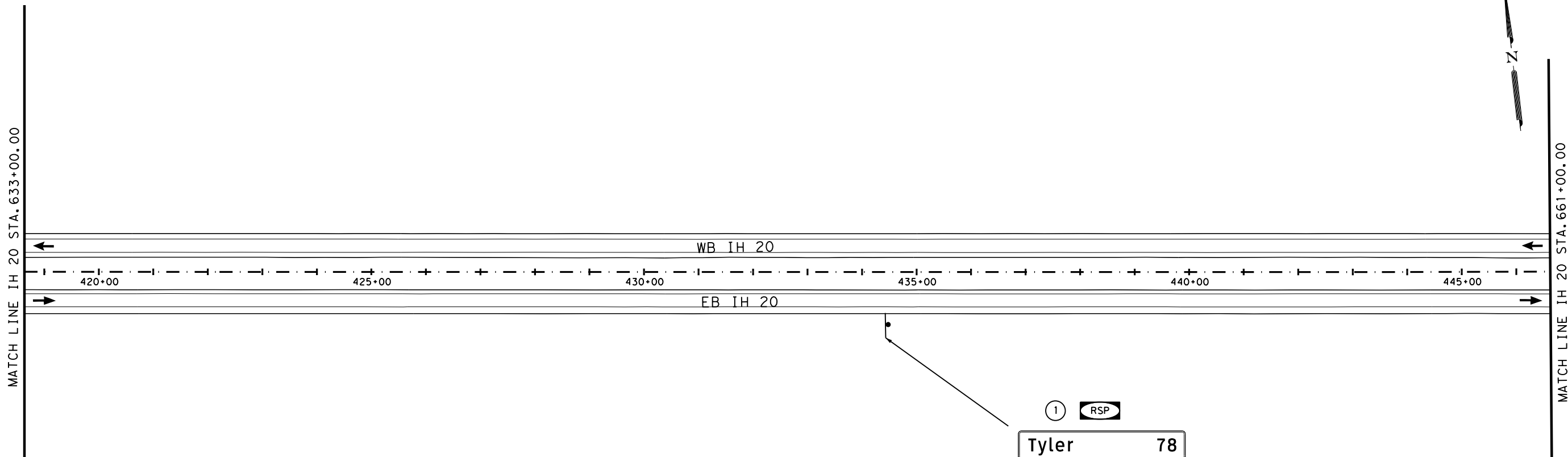

SIGNING LEGEND

- (E) EXISTING SIGN TO REMAIN
- (3) SIGN TO BE INSTALLED
- RSA REMOVE SMALL SIGN ASSEMBLY
- RLA-1 REMOVE LARGE GROUND ASSEMBLY
- RSP REPLACE SMALL SIGN PANEL
- RLP REPLACE LARGE SIGN PANEL
- ROP REPLACE OVERHEAD PANEL
- ROS-1 REMOVE OVERHEAD STRUCTURE

- * REMOVAL ITEMS THIS SHEET
- (EA) SMALL SIGNS ASSEMBLY
- (EA) OVERHEAD SIGNS
- (EA) LARGE SIGNS ASSEMBLY
- (EA) WALKWAY
- * Removal Quantities are Approximate and Contractor Will be Paid For Actual Work Performed

INSTALL PROPOSED SIGNS
1 FT TO 2 FT BEHIND EXISTING
SIGN LOCATION,
UNLESS OTHERWISE NOTED.



Brenda L. Sanchez, P.E. 03/20/23
Signature of Registrar & Date

©2023

SIGNING LAYOUT IH 20

SCALE: 1"=200' SHEET 64 OF 121

DESIGN/CK BLS	FED. RD. DIV. NO. 6	STATE PROJECT NO. (SEE TITLE SHEET)		HIGHWAY NO. IH 20
CHECK BLS	STATE	DISTRICT DAL	COUNTY VARIOUS	SHEET NO. 168
CHECK MA	TEXAS	SECTION CONTROL	JOB 033, ETC	
CHECK BA	0095	14		

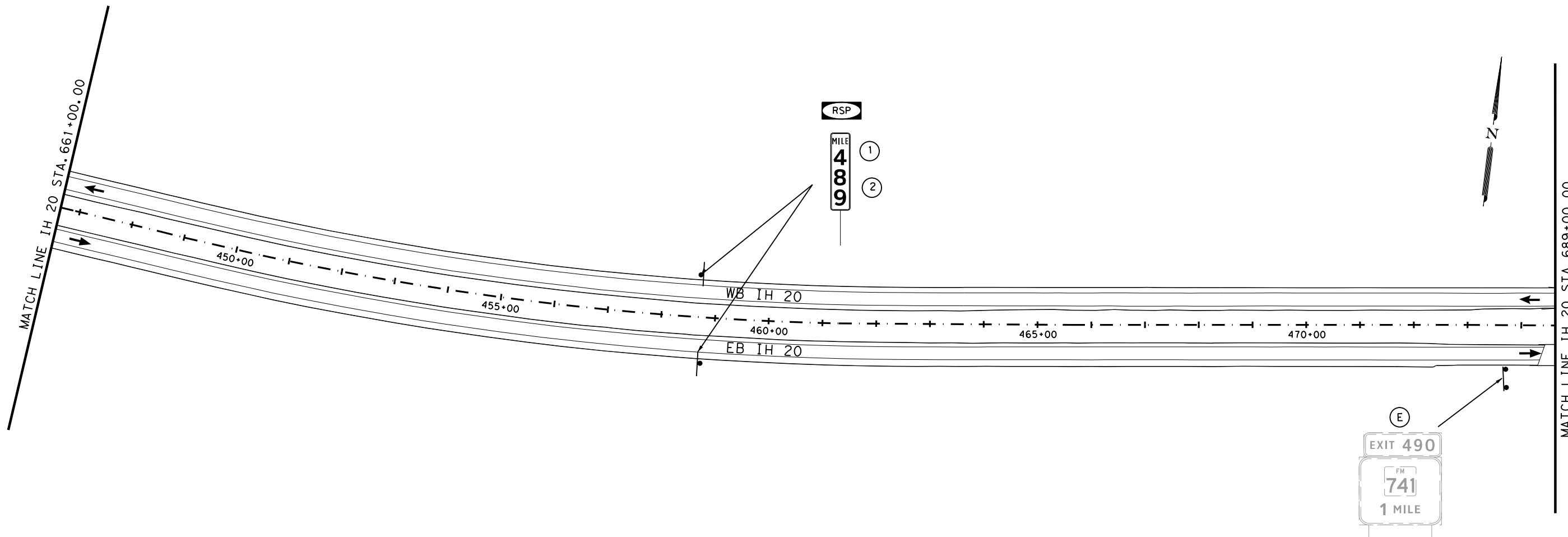

SIGNING LEGEND

- (E) EXISTING SIGN TO REMAIN
- (3) SIGN TO BE INSTALLED
- RSA REMOVE SMALL SIGN ASSEMBLY
- RLA-1 REMOVE LARGE GROUND ASSEMBLY
- RSP REPLACE SMALL SIGN PANEL
- RLP REPLACE LARGE SIGN PANEL
- ROP REPLACE OVERHEAD PANEL
- ROS-1 REMOVE OVERHEAD STRUCTURE

- * REMOVAL ITEMS THIS SHEET
- (EA) SMALL SIGNS ASSEMBLY
- (EA) OVERHEAD SIGNS
- (EA) LARGE SIGNS ASSEMBLY
- (EA) WALKWAY
- * Removal Quantities are Approximate and Contractor Will be Paid For Actual Work Performed

INSTALL PROPOSED SIGNS
1 FT TO 2 FT BEHIND EXISTING
SIGN LOCATION,
UNLESS OTHERWISE NOTED.

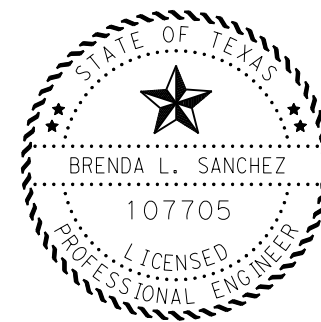

Brenda L. Sanchez, P.E. 03/20/23
Signature of Registrar & Date

Texas Department of Transportation
© 2023

**SIGNING LAYOUT
IH 20**

SCALE: 1"=200' SHEET 65 OF 121

DESIGN/CK BLS	FED. RD. DIV. NO. 6	STATE PROJECT NO. (SEE TITLE SHEET)		HIGHWAY NO. IH 20
CHECK BLS	STATE	DISTRICT DAL	COUNTY VARIOUS	SHEET NO. 169
CHECK MA	TEXAS	SECTION 14	JOB 033, ETC	
CHECK BA	0095			

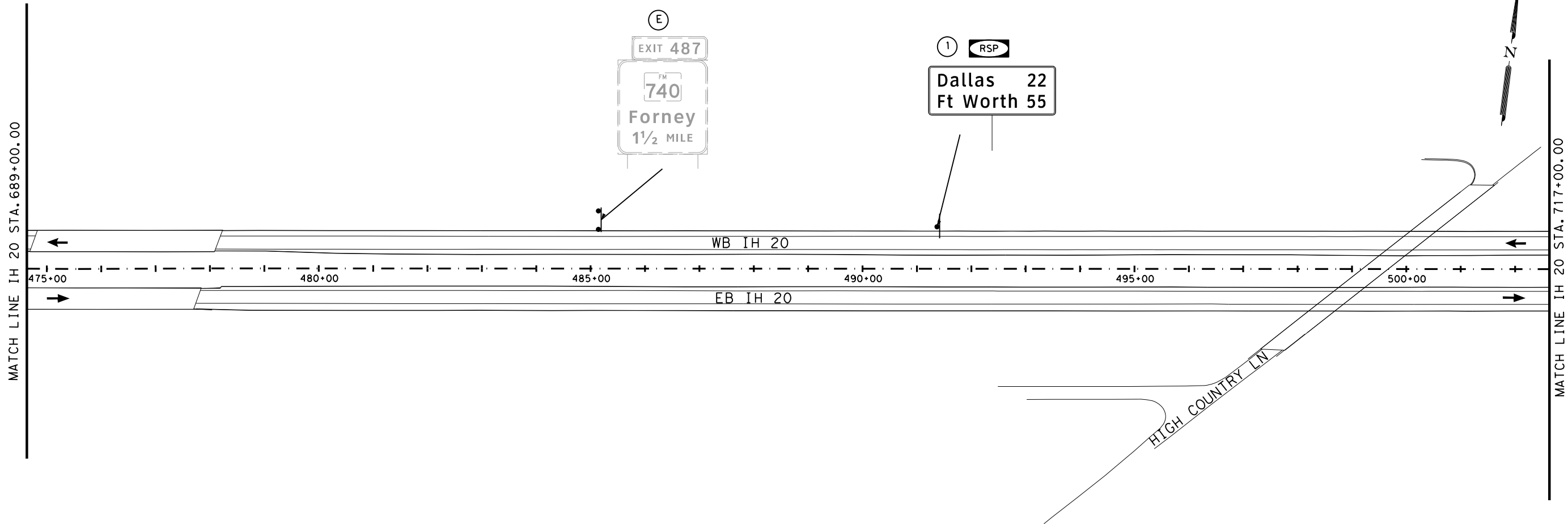

SIGNING LEGEND

- (E) EXISTING SIGN TO REMAIN
 - (3) SIGN TO BE INSTALLED
 - RSA REMOVE SMALL SIGN ASSEMBLY
 - RLA-1 REMOVE LARGE GROUND ASSEMBLY
 - RSP REPLACE SMALL SIGN PANEL
 - RLP REPLACE LARGE SIGN PANEL
 - ROP REPLACE OVERHEAD PANEL
 - ROS-1 REMOVE OVERHEAD STRUCTURE
-
- * REMOVAL ITEMS THIS SHEET
 - (EA) SMALL SIGNS ASSEMBLY
 - (EA) OVERHEAD SIGNS
 - (EA) LARGE SIGNS ASSEMBLY
 - (EA) WALKWAY
 - * Removal Quantities are Approximate and Contractor Will be Paid For Actual Work Performed

INSTALL PROPOSED SIGNS
1 FT TO 2 FT BEHIND EXISTING
SIGN LOCATION,
UNLESS OTHERWISE NOTED.



Brenda L Sanchez, P.E. 03/20/23
Signature of Registrant & Date

Texas Department of Transportation
© 2023

**SIGNING LAYOUT
IH 20**

SCALE: 1"=200' SHEET 66 OF 121

DESIGN/CK BLS	FED. RD. DIV. NO. 6	STATE PROJECT NO. (SEE TITLE SHEET)		HIGHWAY NO. IH 20
CHECK BLS	STATE	DISTRICT DAL	COUNTY VARIOUS	SHEET NO. 170
CHECK MA	TEXAS	SECTION 14	JOB 033, ETC	
CHECK BA	0095			

MATCH LINE IH 20 STA. 717+00.00

MATCH LINE IH 20 STA. 745+00.00

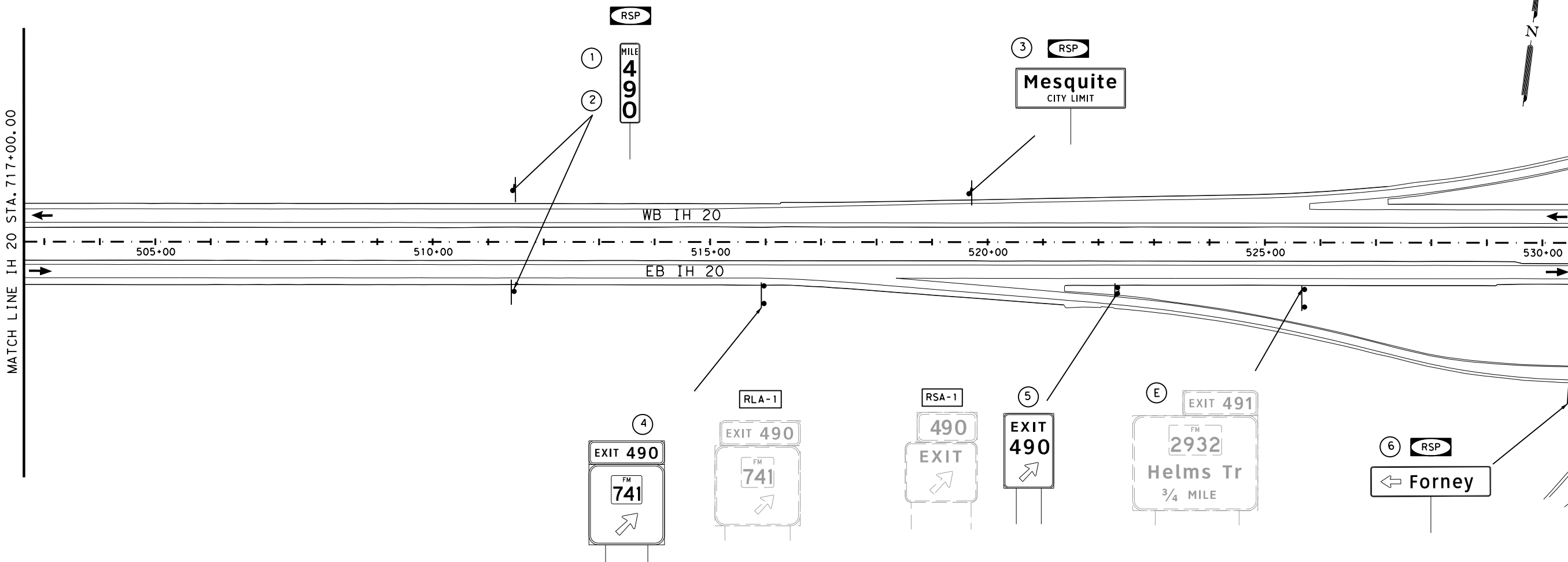

SIGNING LEGEND

- (E) EXISTING SIGN TO REMAIN
- (3) SIGN TO BE INSTALLED
- RSA REMOVE SMALL SIGN ASSEMBLY
- RLA-1 REMOVE LARGE GROUND ASSEMBLY
- RSP REPLACE SMALL SIGN PANEL
- RLP REPLACE LARGE SIGN PANEL
- ROP REPLACE OVERHEAD PANEL
- ROS-1 REMOVE OVERHEAD STRUCTURE

*** REMOVAL ITEMS THIS SHEET**

- 1 (EA) SMALL SIGNS ASSEMBLY
- 1 (EA) OVERHEAD SIGNS
- 1 (EA) LARGE SIGNS ASSEMBLY
- 1 (EA) WALKWAY

* Removal Quantities are Approximate and Contractor Will be Paid For Actual Work Performed

INSTALL PROPOSED SIGNS
1 FT TO 2 FT BEHIND EXISTING
SIGN LOCATION,
UNLESS OTHERWISE NOTED.

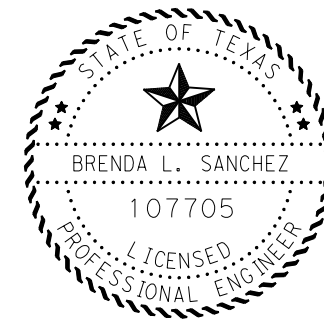

Brenda L. Sanchez, P.E. 03/20/23
Signature of Registrar & Date



**SIGNING LAYOUT
IH 20**

SCALE: 1"=200' SHEET 67 OF 121

DESIGN/CK	FED. RD. DIV. NO.	STATE PROJECT NO.		HIGHWAY NO.
BLS	6	(SEE TITLE SHEET)		IH 20
CHECK	STATE	DISTRICT	COUNTY	SHEET NO.
BLS	TEXAS	DAL	VARIOUS	171
CHECK	CONTROL	SECTION	JOB	
BA	0095	14	033, ETC	

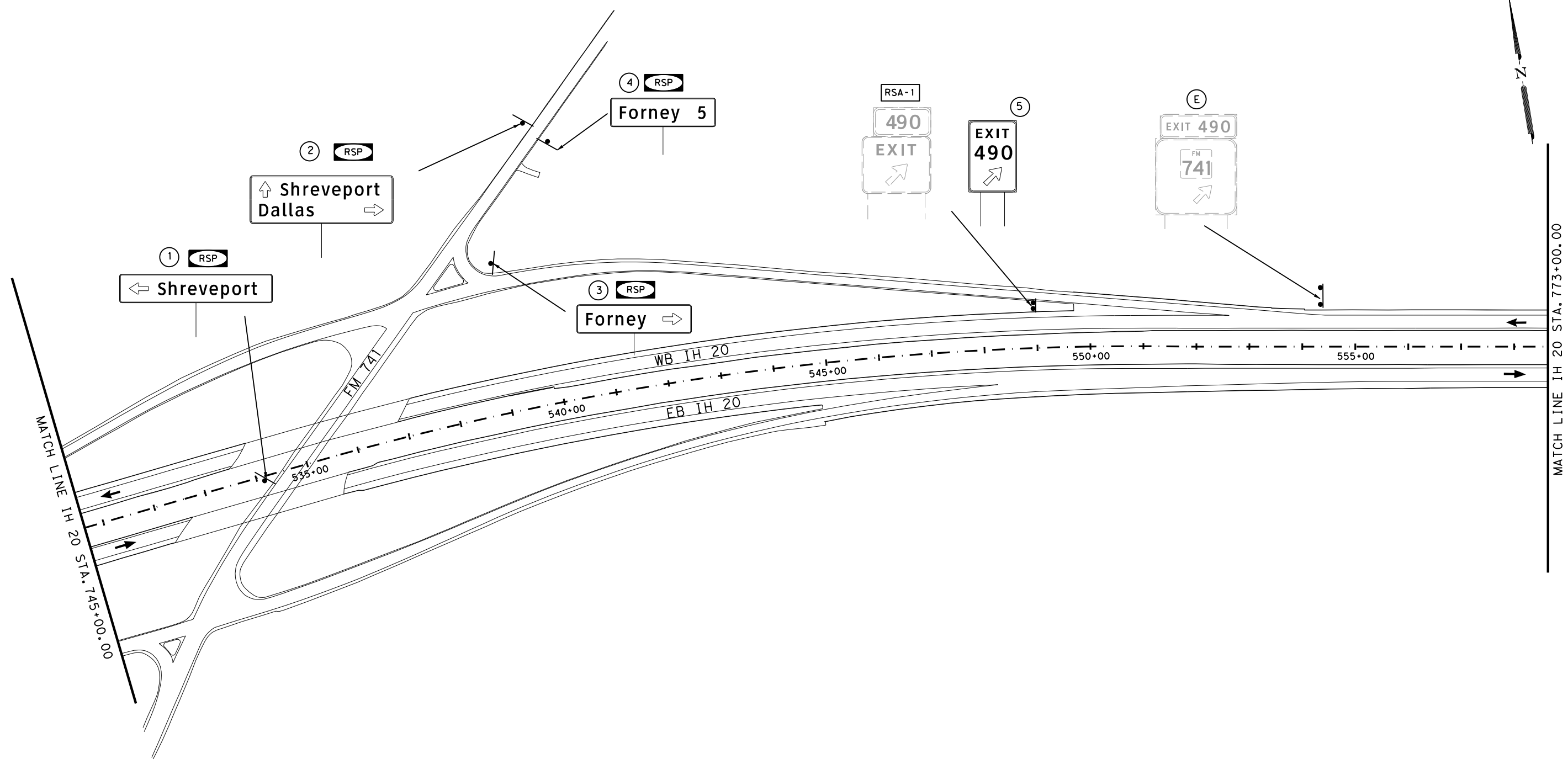

SIGNING LEGEND

- (E) EXISTING SIGN TO REMAIN
 - (3) SIGN TO BE INSTALLED
 - RSA REMOVE SMALL SIGN ASSEMBLY
 - RLA-1 REMOVE LARGE GROUND ASSEMBLY
 - RSP REPLACE SMALL SIGN PANEL
 - RLP REPLACE LARGE SIGN PANEL
 - ROP REPLACE OVERHEAD PANEL
 - ROS-1 REMOVE OVERHEAD STRUCTURE
-
- * REMOVAL ITEMS THIS SHEET
 - (EA) SMALL SIGNS ASSEMBLY
 - (EA) OVERHEAD SIGNS
 - (EA) LARGE SIGNS ASSEMBLY
 - (EA) WALKWAY
 - * Removal Quantities are Approximate and Contractor Will be Paid For Actual Work Performed

INSTALL PROPOSED SIGNS
1 FT TO 2 FT BEHIND EXISTING
SIGN LOCATION,
UNLESS OTHERWISE NOTED.



Brenda L Sanchez, P.E. 03/20/23
Signature of Registrant & Date

Texas Department of Transportation
© 2023

**SIGNING LAYOUT
IH 20**

SCALE: 1"=200' SHEET 68 OF 121

DESIGN/CK BLS	FED. RD. DIV. NO. 6	STATE PROJECT NO. (SEE TITLE SHEET)		HIGHWAY NO. IH 20
CHECK BLS	STATE	DISTRICT	COUNTY	SHEET NO.
CHECK MA	TEXAS	DAL	VARIOUS	172
CHECK BA	CONTROL	SECTION	JOB	
	0095	14	033, ETC	

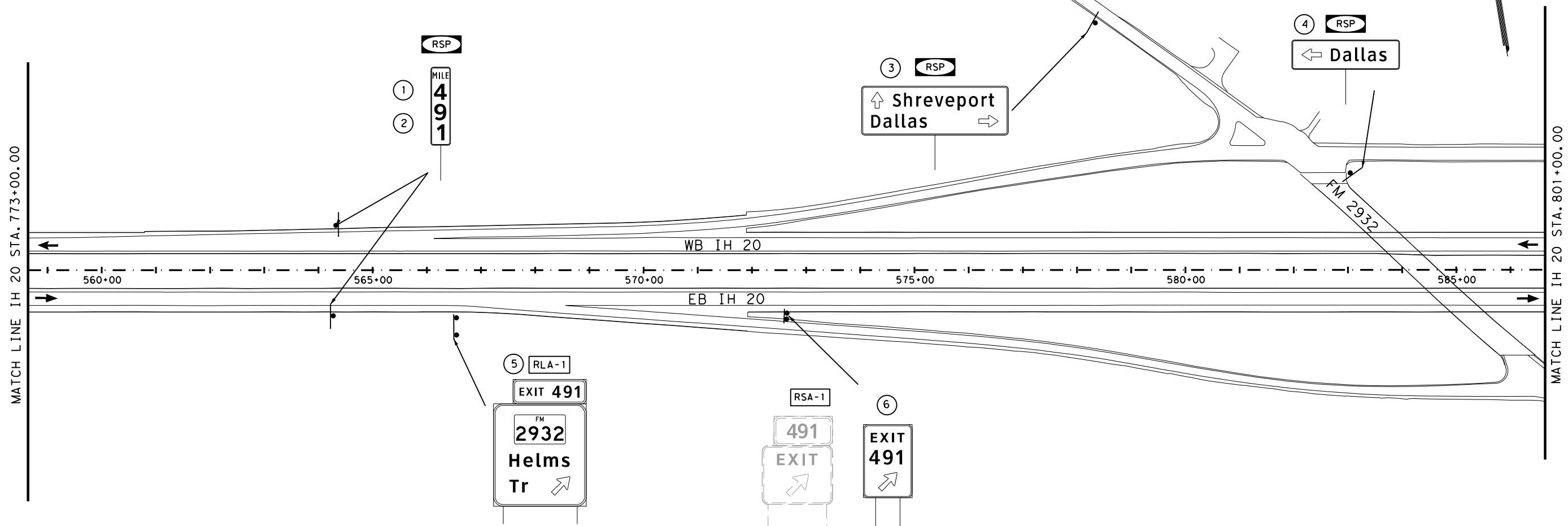

SIGNING LEGEND

- (E) EXISTING SIGN TO REMAIN
- (3) SIGN TO BE INSTALLED
- RSA REMOVE SMALL SIGN ASSEMBLY
- RLA-1 REMOVE LARGE GROUND ASSEMBLY
- RSP REPLACE SMALL SIGN PANEL
- RLP REPLACE LARGE SIGN PANEL
- ROP REPLACE OVERHEAD PANEL
- ROS-1 REMOVE OVERHEAD STRUCTURE

- * REMOVAL ITEMS THIS SHEET
- 1 (EA) SMALL SIGNS ASSEMBLY
 - (EA) OVERHEAD SIGNS
 - 1 (EA) LARGE SIGNS ASSEMBLY
 - (EA) WALKWAY
- * Removal Quantities are Approximate and Contractor Will be Paid For Actual Work Performed

INSTALL PROPOSED SIGNS
1 FT TO 2 FT BEHIND EXISTING
SIGN LOCATION,
UNLESS OTHERWISE NOTED.



Brenda L. Sanchez, P.E. 03/20/23
Signature of Registrar & Date



**SIGNING LAYOUT
IH 20**

SCALE: 1"=200' SHEET 69 OF 121

DESIGN/CK	FED. RD. DIV. NO.	STATE PROJECT NO.		HIGHWAY NO.
BLS	6	(SEE TITLE SHEET)		IH 20
CHECK	STATE	DISTRICT	COUNTY	SHEET NO.
BLS	TEXAS	DAL	VARIOUS	173
CHECK	CONTROL	SECTION	JOB	
BA	0095	14	033, ETC	

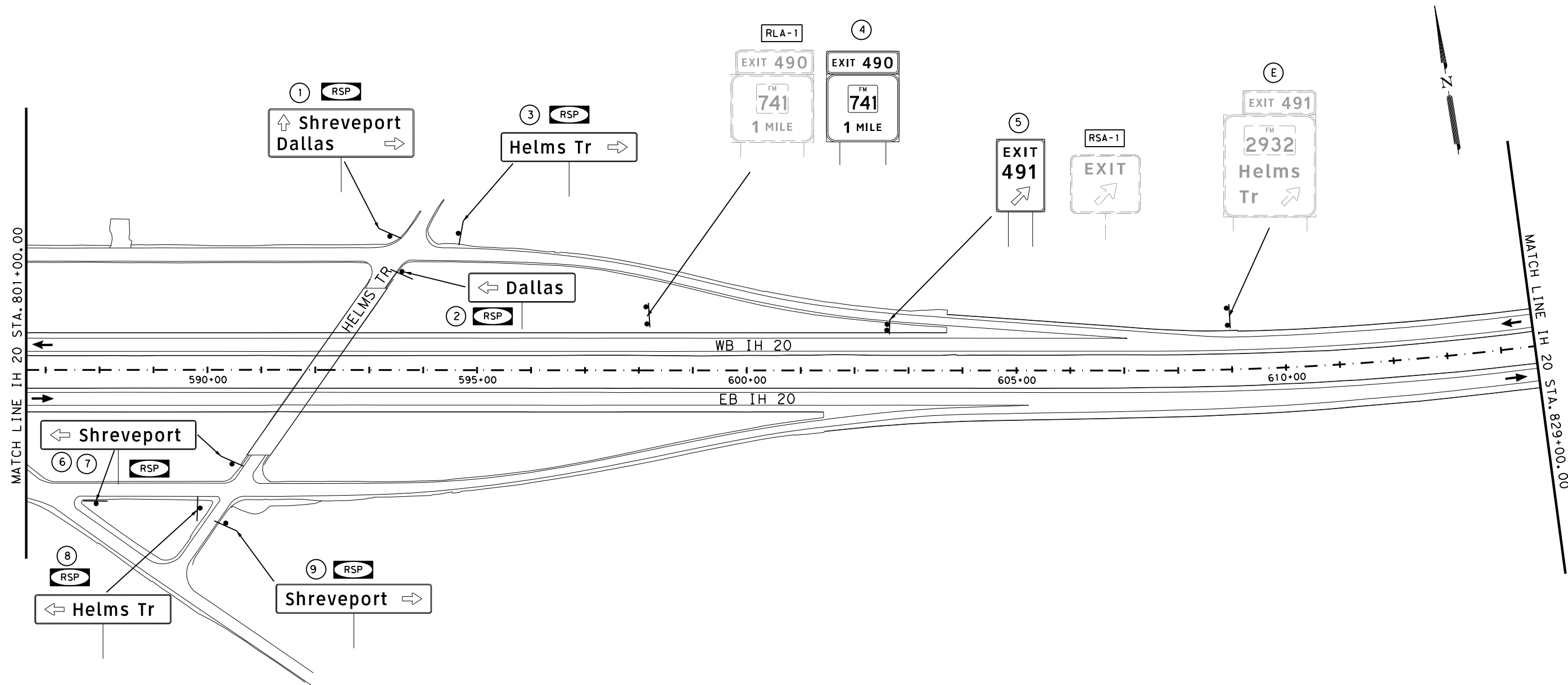

SIGNING LEGEND

- (E) EXISTING SIGN TO REMAIN
- (3) SIGN TO BE INSTALLED
- RSA REMOVE SMALL SIGN ASSEMBLY
- RLA-1 REMOVE LARGE GROUND ASSEMBLY
- RSP REPLACE SMALL SIGN PANEL
- RLP REPLACE LARGE SIGN PANEL
- ROP REPLACE OVERHEAD PANEL
- ROS-1 REMOVE OVERHEAD STRUCTURE

- * REMOVAL ITEMS THIS SHEET
- 1 (EA) SMALL SIGNS ASSEMBLY
 - (EA) OVERHEAD SIGNS
 - 1 (EA) LARGE SIGNS ASSEMBLY
 - (EA) WALKWAY
- * Removal Quantities are Approximate and Contractor Will be Paid For Actual Work Performed

INSTALL PROPOSED SIGNS
1 FT TO 2 FT BEHIND EXISTING
SIGN LOCATION,
UNLESS OTHERWISE NOTED.

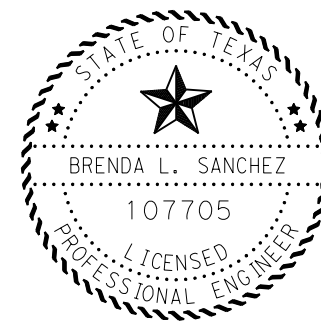

Brenda L Sanchez, P.E. 03/20/23
Signature of Registrar & Date



**SIGNING LAYOUT
IH 20**

SCALE: 1"=200' SHEET 70 OF 121

DESIGN/CK	FED. RD. DIV. NO.	STATE PROJECT NO.		HIGHWAY NO.
BLS	6	(SEE TITLE SHEET)		IH 20
CHECK	STATE	DISTRICT	COUNTY	SHEET NO.
BLS	TEXAS	DAL	VARIOUS	174
CHECK	CONTROL	SECTION	JOB	
BA	0095	14	033, ETC	

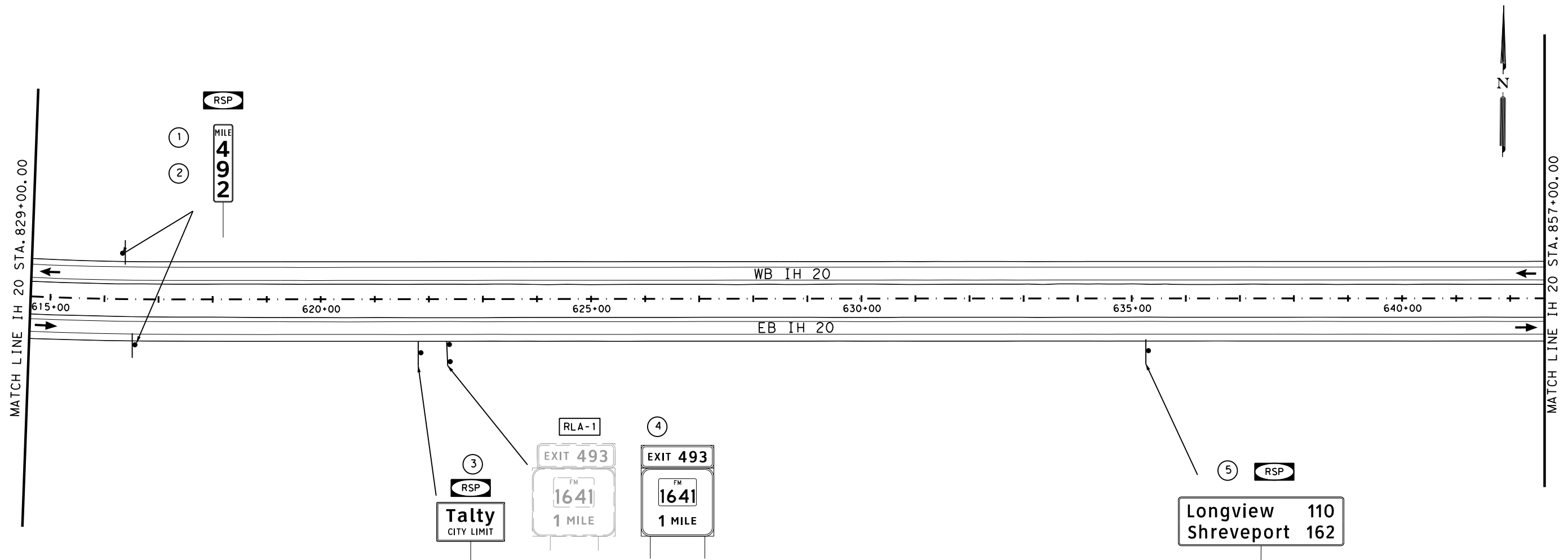

SIGNING LEGEND

- (E) EXISTING SIGN TO REMAIN
- (3) SIGN TO BE INSTALLED
- RSA REMOVE SMALL SIGN ASSEMBLY
- RLA-1 REMOVE LARGE GROUND ASSEMBLY
- RSP REPLACE SMALL SIGN PANEL
- RLP REPLACE LARGE SIGN PANEL
- ROP REPLACE OVERHEAD PANEL
- ROS-1 REMOVE OVERHEAD STRUCTURE

- * REMOVAL ITEMS THIS SHEET
- (EA) SMALL SIGNS ASSEMBLY
- (EA) OVERHEAD SIGNS
- 1 (EA) LARGE SIGNS ASSEMBLY
- (EA) WALKWAY
- * Removal Quantities are Approximate and Contractor Will be Paid For Actual Work Performed

INSTALL PROPOSED SIGNS
1 FT TO 2 FT BEHIND EXISTING
SIGN LOCATION,
UNLESS OTHERWISE NOTED.

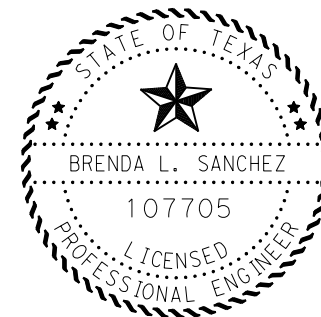

Brenda L Sanchez, P.E. 03/20/23
Signature of Registrar & Date

Texas Department of Transportation
© 2023

**SIGNING LAYOUT
IH 20**

SCALE: 1"=200' SHEET 71 OF 121

DESIGN/CK BLS	FED. RD. DIV. NO. 6	STATE PROJECT NO. (SEE TITLE SHEET)		HIGHWAY NO. IH 20
CHECK BLS	STATE	DISTRICT DAL	COUNTY VARIOUS	SHEET NO. 175
CHECK MA	TEXAS	SECTION 14	JOB 033, ETC	
CHECK BA	CONTROL 0095			

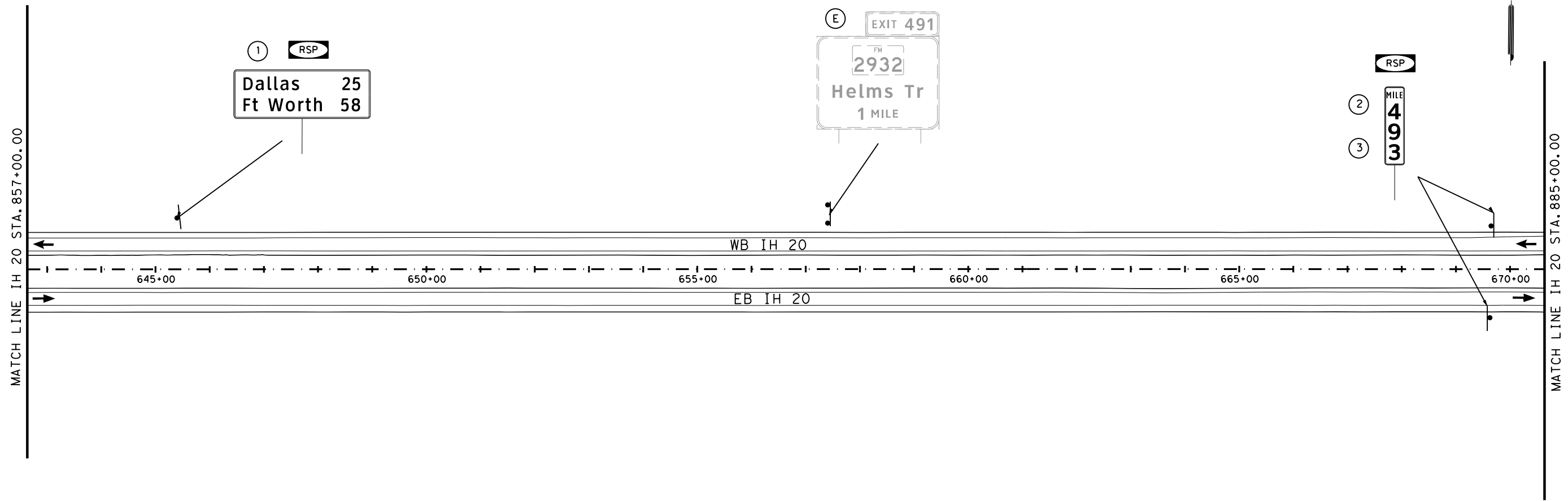

SIGNING LEGEND

- (E) EXISTING SIGN TO REMAIN
- (3) SIGN TO BE INSTALLED
- RSA REMOVE SMALL SIGN ASSEMBLY
- RLA-1 REMOVE LARGE GROUND ASSEMBLY
- RSP REPLACE SMALL SIGN PANEL
- RLP REPLACE LARGE SIGN PANEL
- ROP REPLACE OVERHEAD PANEL
- ROS-1 REMOVE OVERHEAD STRUCTURE

- * REMOVAL ITEMS THIS SHEET
- (EA) SMALL SIGNS ASSEMBLY
 - (EA) OVERHEAD SIGNS
 - (EA) LARGE SIGNS ASSEMBLY
 - (EA) WALKWAY
- * Removal Quantities are Approximate and Contractor Will be Paid For Actual Work Performed

INSTALL PROPOSED SIGNS
1 FT TO 2 FT BEHIND EXISTING
SIGN LOCATION,
UNLESS OTHERWISE NOTED.

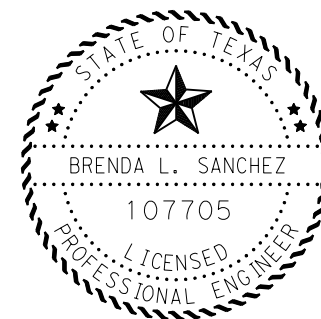

Brenda L Sanchez, P.E. 03/20/23
Signature of Registrant & Date

Texas Department of Transportation
© 2023

**SIGNING LAYOUT
IH 20**

SCALE: 1"=200' SHEET 72 OF 121

DESIGN/CK BLS	FED. RD. DIV. NO. 6	STATE PROJECT NO. (SEE TITLE SHEET)		HIGHWAY NO. IH 20
CHECK BLS	STATE	DISTRICT DAL	COUNTY VARIOUS	SHEET NO. 176
CHECK MA	TEXAS	SECTION 14	JOB 033, ETC	
CHECK BA	CONTROL 0095			

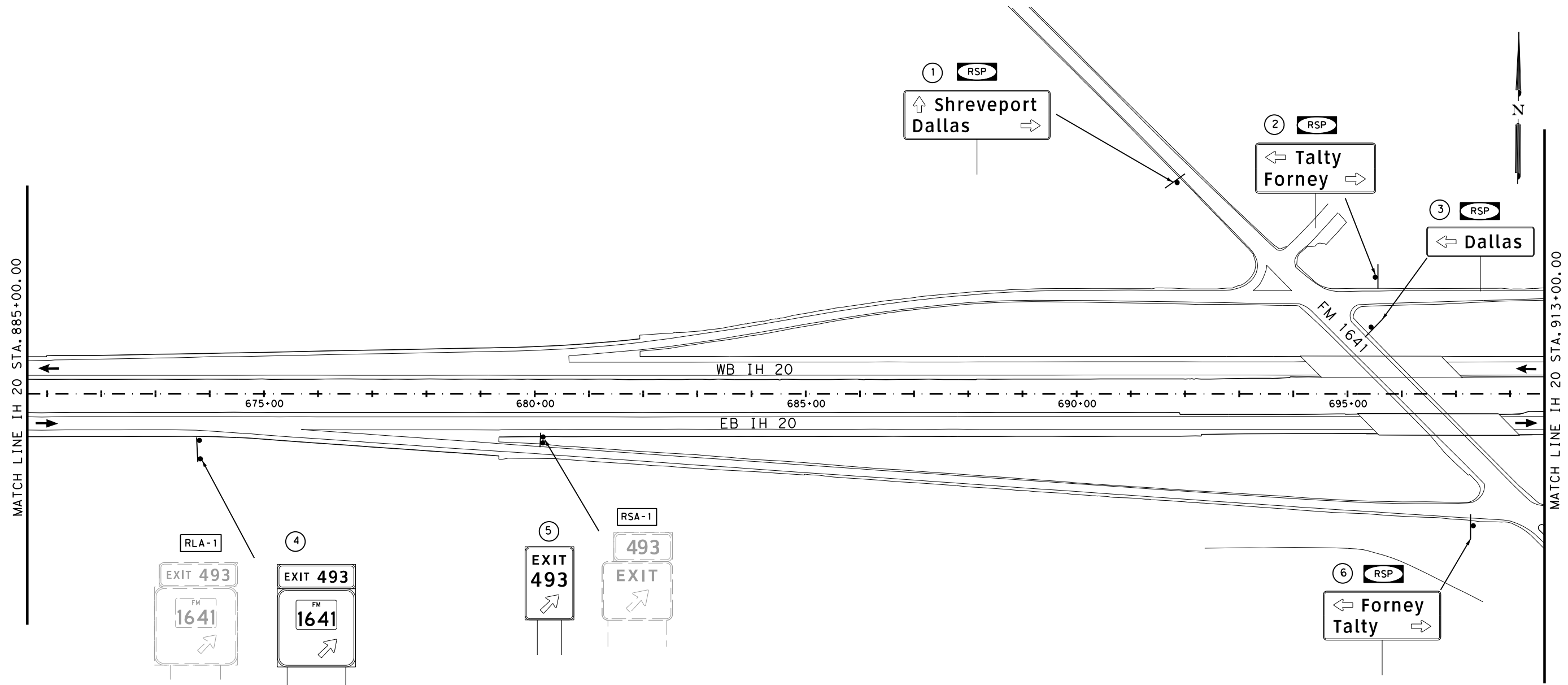

SIGNING LEGEND

- (E) EXISTING SIGN TO REMAIN
- (3) SIGN TO BE INSTALLED
- RSA REMOVE SMALL SIGN ASSEMBLY
- RLA-1 REMOVE LARGE GROUND ASSEMBLY
- RSP REPLACE SMALL SIGN PANEL
- RLP REPLACE LARGE SIGN PANEL
- ROP REPLACE OVERHEAD PANEL
- ROS-1 REMOVE OVERHEAD STRUCTURE

- * REMOVAL ITEMS THIS SHEET
- 1 (EA) SMALL SIGNS ASSEMBLY
 - (EA) OVERHEAD SIGNS
 - 1 (EA) LARGE SIGNS ASSEMBLY
 - (EA) WALKWAY
- * Removal Quantities are Approximate and Contractor Will be Paid For Actual Work Performed

INSTALL PROPOSED SIGNS
1 FT TO 2 FT BEHIND EXISTING
SIGN LOCATION,
UNLESS OTHERWISE NOTED.



Brenda L. Sanchez, P.E. 03/20/23
Signature of Registrant & Date

Texas Department of Transportation
© 2023

**SIGNING LAYOUT
IH 20**

SCALE: 1"=200' SHEET 73 OF 121

DESIGN/CK BLS	FED. RD. DIV. NO. 6	STATE PROJECT NO. (SEE TITLE SHEET)		HIGHWAY NO. IH 20
CHECK BLS	STATE	DISTRICT	COUNTY	SHEET NO.
CHECK MA	TEXAS	DAL	VARIOUS	177
CHECK BA	CONTROL	SECTION	JOB	
	0095	14	033, ETC	

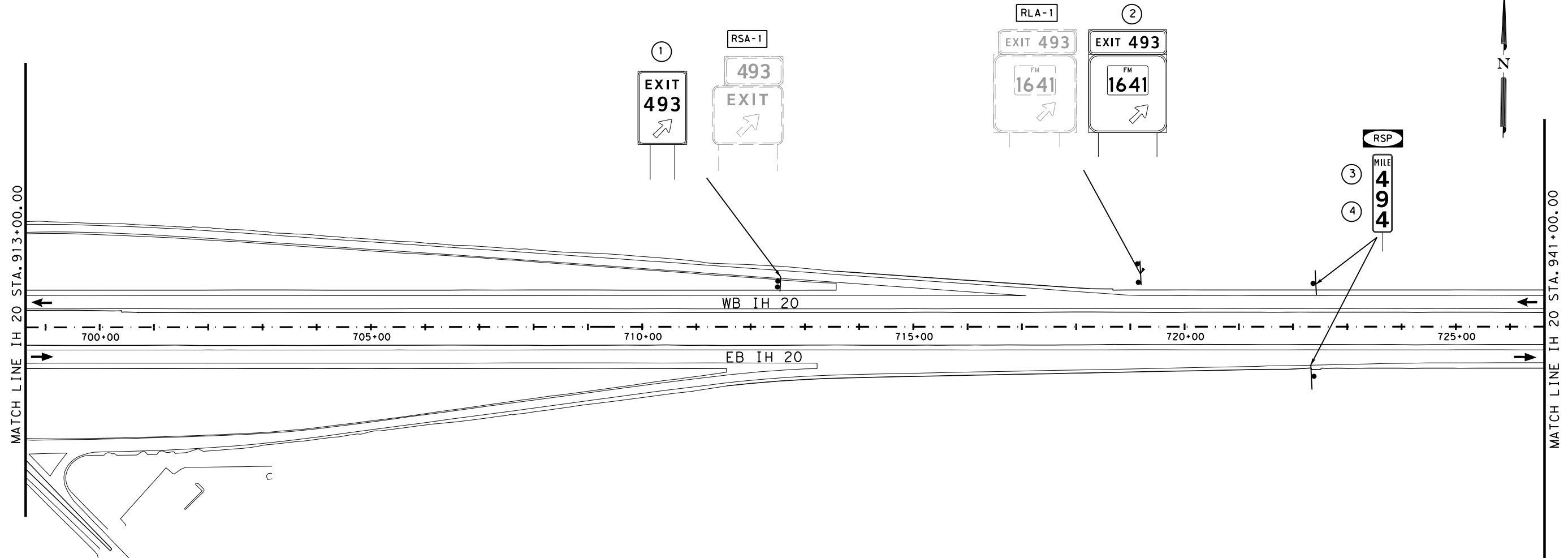

SIGNING LEGEND

- (E) EXISTING SIGN TO REMAIN
- (3) SIGN TO BE INSTALLED
- RSA REMOVE SMALL SIGN ASSEMBLY
- RLA-1 REMOVE LARGE GROUND ASSEMBLY
- RSP REPLACE SMALL SIGN PANEL
- RLP REPLACE LARGE SIGN PANEL
- ROP REPLACE OVERHEAD PANEL
- ROS-1 REMOVE OVERHEAD STRUCTURE

- * REMOVAL ITEMS THIS SHEET
- 1 (EA) SMALL SIGNS ASSEMBLY
 - (EA) OVERHEAD SIGNS
 - 1 (EA) LARGE SIGNS ASSEMBLY
 - (EA) WALKWAY
- * Removal Quantities are Approximate and Contractor Will be Paid For Actual Work Performed

INSTALL PROPOSED SIGNS
1 FT TO 2 FT BEHIND EXISTING
SIGN LOCATION,
UNLESS OTHERWISE NOTED.

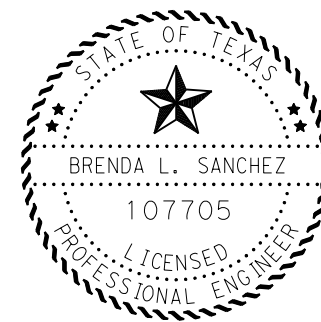

Brenda L Sanchez, P.E. 03/20/23
Signature of Registrar & Date

Texas Department of Transportation
© 2023

**SIGNING LAYOUT
IH 20**

SCALE: 1"=200' SHEET 74 OF 121

DESIGN/CK BLS	FED. RD. DIV. NO. 6	STATE PROJECT NO. (SEE TITLE SHEET)		HIGHWAY NO. IH 20
CHECK BLS	STATE	DISTRICT	COUNTY	SHEET NO.
CHECK MA	TEXAS	DAL	VARIOUS	178
CHECK BA	CONTROL	SECTION	JOB	
	0095	14	033, ETC	

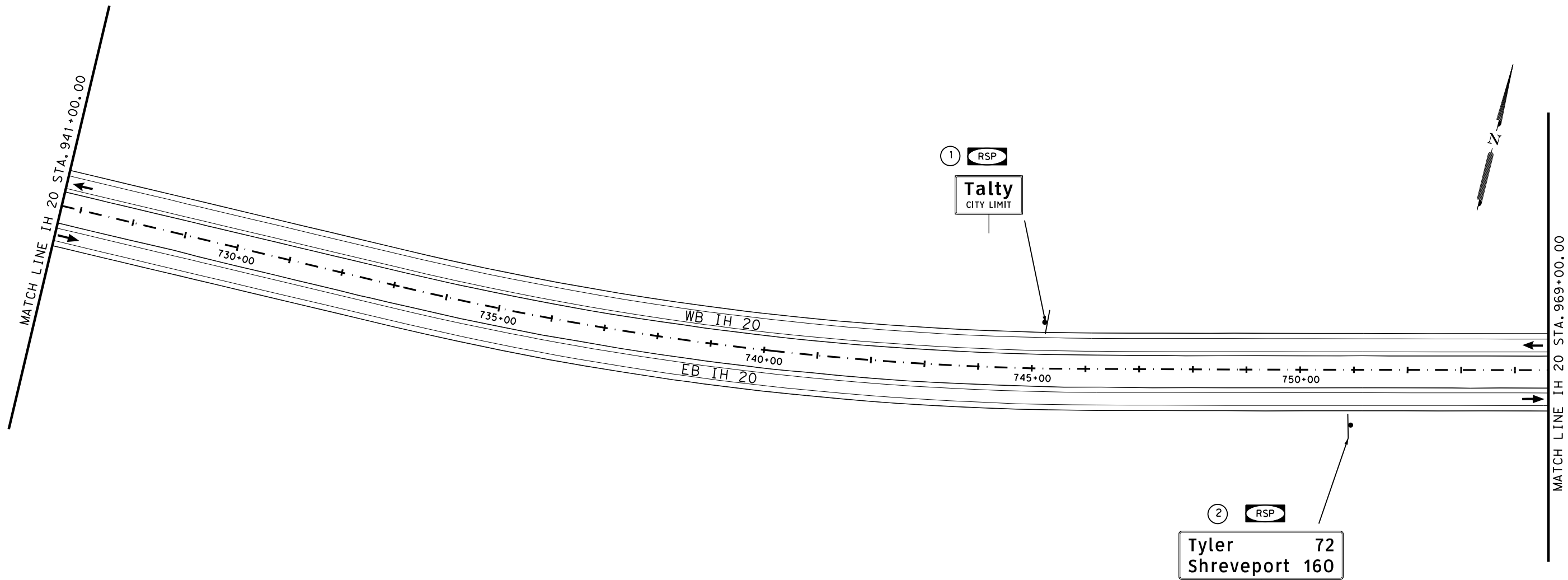

SIGNING LEGEND

- (E) EXISTING SIGN TO REMAIN
- (3) SIGN TO BE INSTALLED
- RSA REMOVE SMALL SIGN ASSEMBLY
- RLA-1 REMOVE LARGE GROUND ASSEMBLY
- RSP REPLACE SMALL SIGN PANEL
- RLP REPLACE LARGE SIGN PANEL
- ROP REPLACE OVERHEAD PANEL
- ROS-1 REMOVE OVERHEAD STRUCTURE

- * REMOVAL ITEMS THIS SHEET
- (EA) SMALL SIGNS ASSEMBLY
 - (EA) OVERHEAD SIGNS
 - (EA) LARGE SIGNS ASSEMBLY
 - (EA) WALKWAY
- * Removal Quantities are Approximate and Contractor Will be Paid For Actual Work Performed

INSTALL PROPOSED SIGNS
1 FT TO 2 FT BEHIND EXISTING
SIGN LOCATION,
UNLESS OTHERWISE NOTED.



Brenda L. Sanchez, P.E. 03/20/23
Signature of Registrar & Date

Texas Department of Transportation
© 2023

**SIGNING LAYOUT
IH 20**

SCALE: 1"=200' SHEET 75 OF 121

DESIGN/CK BLS	FED. RD. DIV. NO. 6	STATE PROJECT NO. (SEE TITLE SHEET)		HIGHWAY NO. IH 20
CHECK BLS	STATE	DISTRICT DAL	COUNTY VARIOUS	SHEET NO. 179
CHECK MA	TEXAS	SECTION CONTROL	JOB VARIOUS	
CHECK BA	0095	14	033, ETC	

MATCH LINE IH 20 STA. 969+00.00

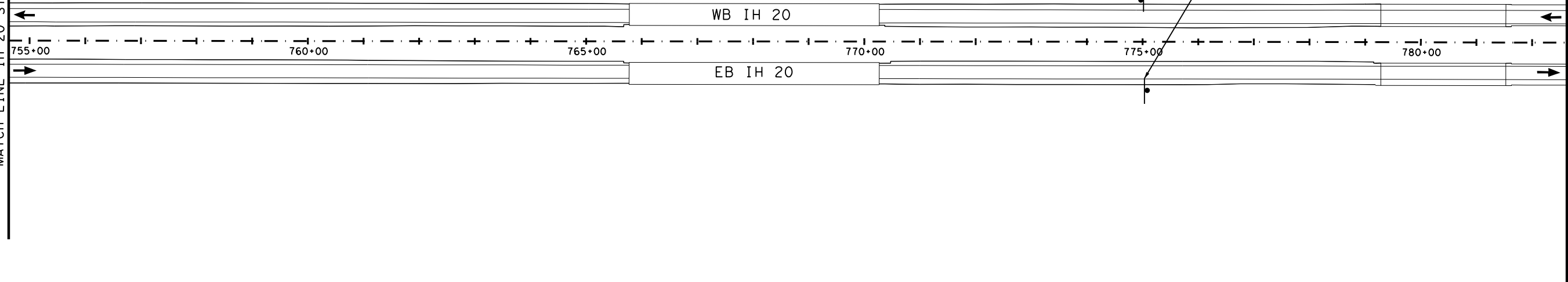

MATCH LINE IH 20 STA. 997+00.00

SIGNING LEGEND

- (E) EXISTING SIGN TO REMAIN
- (3) SIGN TO BE INSTALLED
- RSA REMOVE SMALL SIGN ASSEMBLY
- RLA-1 REMOVE LARGE GROUND ASSEMBLY
- RSP REPLACE SMALL SIGN PANEL
- RLP REPLACE LARGE SIGN PANEL
- ROP REPLACE OVERHEAD PANEL
- ROS-1 REMOVE OVERHEAD STRUCTURE

- * REMOVAL ITEMS THIS SHEET
- (EA) SMALL SIGNS ASSEMBLY
 - (EA) OVERHEAD SIGNS
 - 1 (EA) LARGE SIGNS ASSEMBLY
 - (EA) WALKWAY
- * Removal Quantities are Approximate and Contractor Will be Paid For Actual Work Performed

INSTALL PROPOSED SIGNS
1 FT TO 2 FT BEHIND EXISTING
SIGN LOCATION,
UNLESS OTHERWISE NOTED.

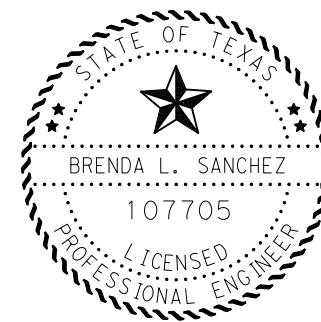

Brenda L Sanchez, P.E. 03/20/23
Signature of Registrar & Date

Texas Department of Transportation
© 2023

**SIGNING LAYOUT
IH 20**

SCALE: 1"=200' SHEET 76 OF 121

DESIGN/CK BLS	FED. RD. DIV. NO. 6	STATE PROJECT NO. (SEE TITLE SHEET)		HIGHWAY NO. IH 20
CHECK BLS	STATE	DISTRICT DAL	COUNTY VARIOUS	SHEET NO. 180
CHECK MA	TEXAS	SECTION CONTROL	JOB VARIOUS	
CHECK BA	0095	14	033, ETC	

NO WORK TO BE DONE ON THIS SHEET



MATCH LINE IH 20 STA. 997+00.00

MATCH LINE IH 20 STA. 1025+00.00

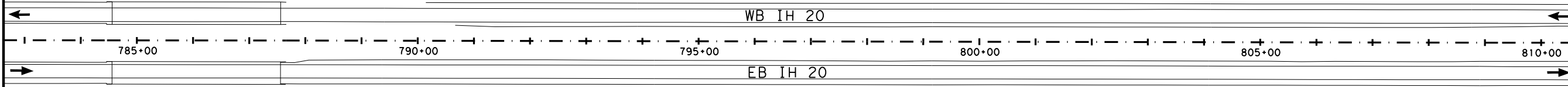

SIGNING LEGEND

- (E) EXISTING SIGN TO REMAIN
- (3) SIGN TO BE INSTALLED
- RSA REMOVE SMALL SIGN ASSEMBLY
- RLA-1 REMOVE LARGE GROUND ASSEMBLY
- RSP REPLACE SMALL SIGN PANEL
- RLP REPLACE LARGE SIGN PANEL
- ROP REPLACE OVERHEAD PANEL
- ROS-1 REMOVE OVERHEAD STRUCTURE

- * REMOVAL ITEMS THIS SHEET
- (EA) SMALL SIGNS ASSEMBLY
- (EA) OVERHEAD SIGNS
- (EA) LARGE SIGNS ASSEMBLY
- (EA) WALKWAY
- * Removal Quantities are Approximate and Contractor Will be Paid For Actual Work Performed

INSTALL PROPOSED SIGNS 1 FT TO 2 FT BEHIND EXISTING SIGN LOCATION, UNLESS OTHERWISE NOTED.



Brenda L Sanchez, P.E. 03/20/23
Signature of Registrant & Date

Texas Department of Transportation
© 2023

SIGNING LAYOUT
IH 20

SCALE: 1"=200' SHEET 77 OF 121

DESIGN/CHECK	FED. RD. DIV. NO.	STATE PROJECT NO.		HIGHWAY NO.
BLS	6	(SEE TITLE SHEET)		IH 20
CHECK	STATE	DISTRICT	COUNTY	SHEET NO.
MA	TEXAS	DAL	VARIOUS	181
CHECK	CONTROL	SECTION	JOB	
BA	0095	14	033, ETC	

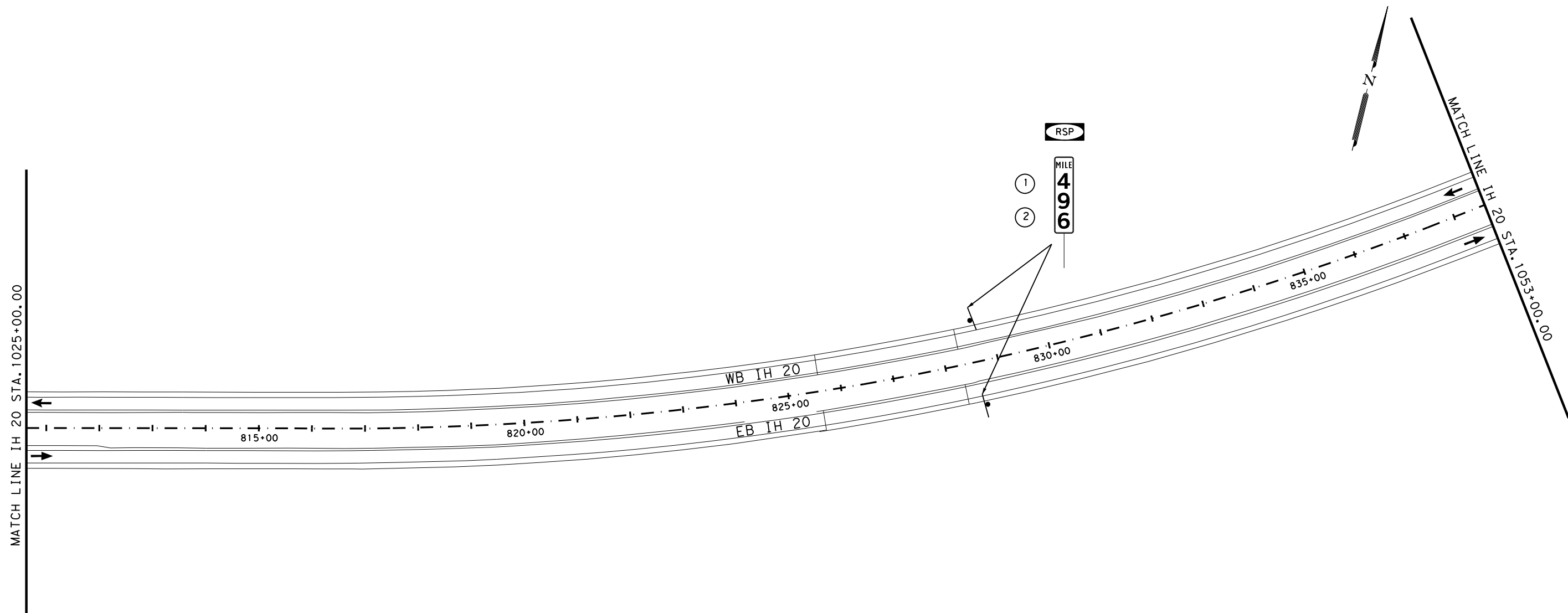

SIGNING LEGEND

- (E) EXISTING SIGN TO REMAIN
- (3) SIGN TO BE INSTALLED
- RSA REMOVE SMALL SIGN ASSEMBLY
- RLA-1 REMOVE LARGE GROUND ASSEMBLY
- RSP REPLACE SMALL SIGN PANEL
- RLP REPLACE LARGE SIGN PANEL
- ROP REPLACE OVERHEAD PANEL
- ROS-1 REMOVE OVERHEAD STRUCTURE

- * REMOVAL ITEMS THIS SHEET
- (EA) SMALL SIGNS ASSEMBLY
- (EA) OVERHEAD SIGNS
- (EA) LARGE SIGNS ASSEMBLY
- (EA) WALKWAY
- * Removal Quantities are Approximate and Contractor Will be Paid For Actual Work Performed

INSTALL PROPOSED SIGNS
1 FT TO 2 FT BEHIND EXISTING
SIGN LOCATION,
UNLESS OTHERWISE NOTED.

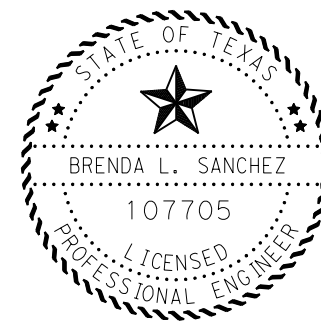

Brenda L. Sanchez, P.E. 03/20/23
Signature of Registrar & Date

Texas Department of Transportation
© 2023

**SIGNING LAYOUT
IH 20**

SCALE: 1"=200' SHEET 78 OF 121

DESIGN/CK BLS	FED. RD. DIV. NO. 6	STATE PROJECT NO. (SEE TITLE SHEET)		HIGHWAY NO. IH 20
CHECK BLS	STATE	DISTRICT DAL	COUNTY VARIOUS	SHEET NO. 182
CHECK MA	TEXAS	SECTION 14	JOB 033, ETC	
CHECK BA	0095			

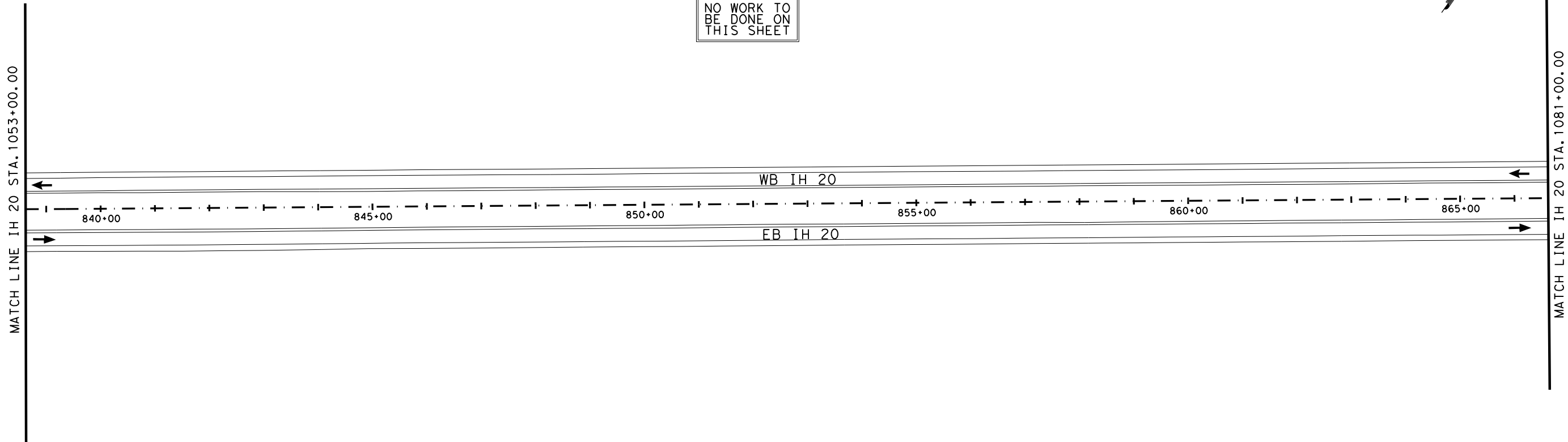

SIGNING LEGEND

- (E) EXISTING SIGN TO REMAIN
- (3) SIGN TO BE INSTALLED
- RSA REMOVE SMALL SIGN ASSEMBLY
- RLA-1 REMOVE LARGE GROUND ASSEMBLY
- RSP REPLACE SMALL SIGN PANEL
- RLP REPLACE LARGE SIGN PANEL
- ROP REPLACE OVERHEAD PANEL
- ROS-1 REMOVE OVERHEAD STRUCTURE

- * REMOVAL ITEMS THIS SHEET
- (EA) SMALL SIGNS ASSEMBLY
- (EA) OVERHEAD SIGNS
- (EA) LARGE SIGNS ASSEMBLY
- (EA) WALKWAY
- * Removal Quantities are Approximate and Contractor Will be Paid For Actual Work Performed

INSTALL PROPOSED SIGNS
1 FT TO 2 FT BEHIND EXISTING
SIGN LOCATION,
UNLESS OTHERWISE NOTED.

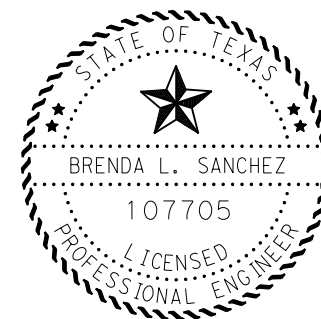

Brenda L. Sanchez, P.E. 03/20/23
Signature of Registrant & Date

Texas Department of Transportation
© 2023

**SIGNING LAYOUT
IH 20**

SCALE: 1"=200' SHEET 79 OF 121

DESIGN/CK BLS	FED. RD. DIV. NO. 6	STATE PROJECT NO. (SEE TITLE SHEET)		HIGHWAY NO. IH 20
CHECK BLS	STATE	DISTRICT DAL	COUNTY VARIOUS	SHEET NO. 183
CHECK MA	TEXAS	SECTION CONTROL	JOB VARIOUS	
CHECK BA	0095	14	033, ETC	

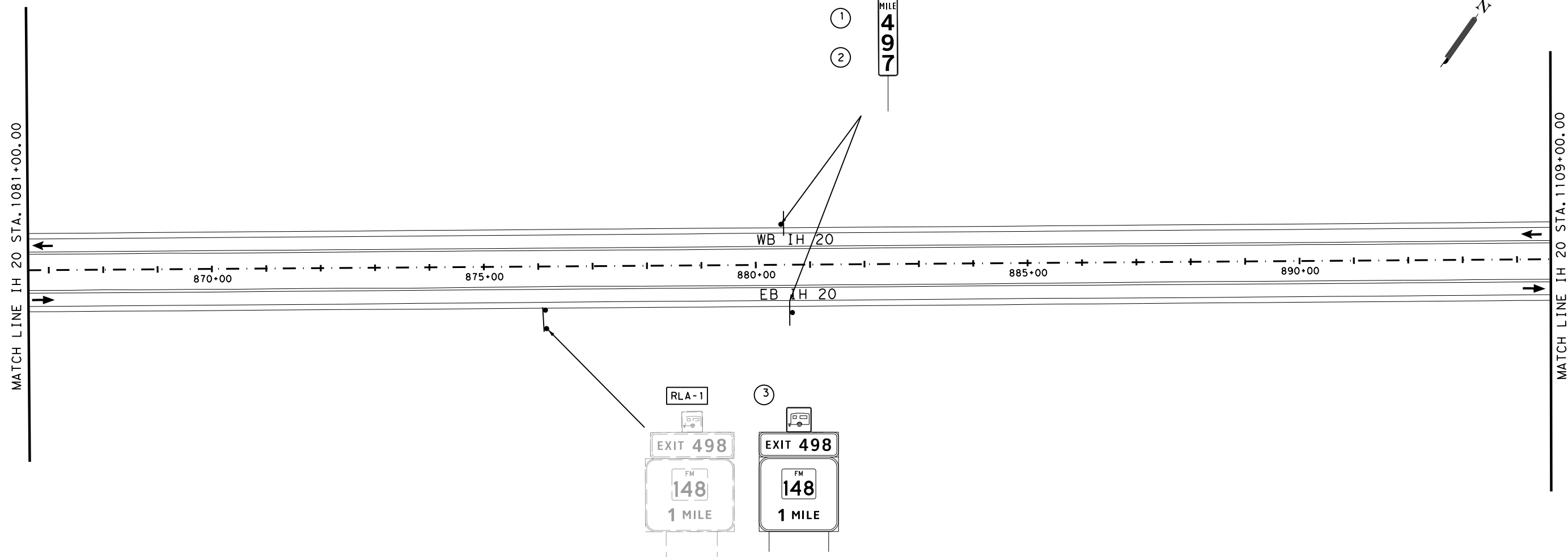

SIGNING LEGEND

- (E) EXISTING SIGN TO REMAIN
- (3) SIGN TO BE INSTALLED
- RSA REMOVE SMALL SIGN ASSEMBLY
- RLA-1 REMOVE LARGE GROUND ASSEMBLY
- RSP REPLACE SMALL SIGN PANEL
- RLP REPLACE LARGE SIGN PANEL
- ROP REPLACE OVERHEAD PANEL
- ROS-1 REMOVE OVERHEAD STRUCTURE

- * REMOVAL ITEMS THIS SHEET
- (EA) SMALL SIGNS ASSEMBLY
 - (EA) OVERHEAD SIGNS
 - 1 (EA) LARGE SIGNS ASSEMBLY
 - (EA) WALKWAY
- * Removal Quantities are Approximate and Contractor Will be Paid For Actual Work Performed

INSTALL PROPOSED SIGNS
1 FT TO 2 FT BEHIND EXISTING
SIGN LOCATION,
UNLESS OTHERWISE NOTED.

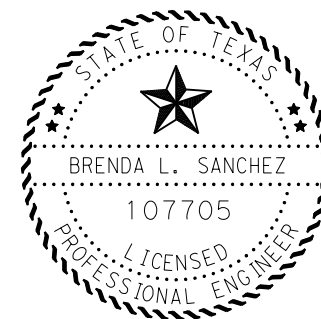

Brenda L Sanchez, P.E. 03/20/23
Signature of Registrant & Date

Texas Department of Transportation
© 2023

**SIGNING LAYOUT
IH 20**

SCALE: 1"=200' SHEET 80 OF 121

DESIGN/CK BLS	FED. RD. DIV. NO. 6	STATE PROJECT NO. (SEE TITLE SHEET)		HIGHWAY NO. IH 20
CHECK BLS	STATE	DISTRICT DAL	COUNTY VARIOUS	SHEET NO. 184
CHECK MA	TEXAS	SECTION 14	JOB 033, ETC	
CHECK BA	0095			

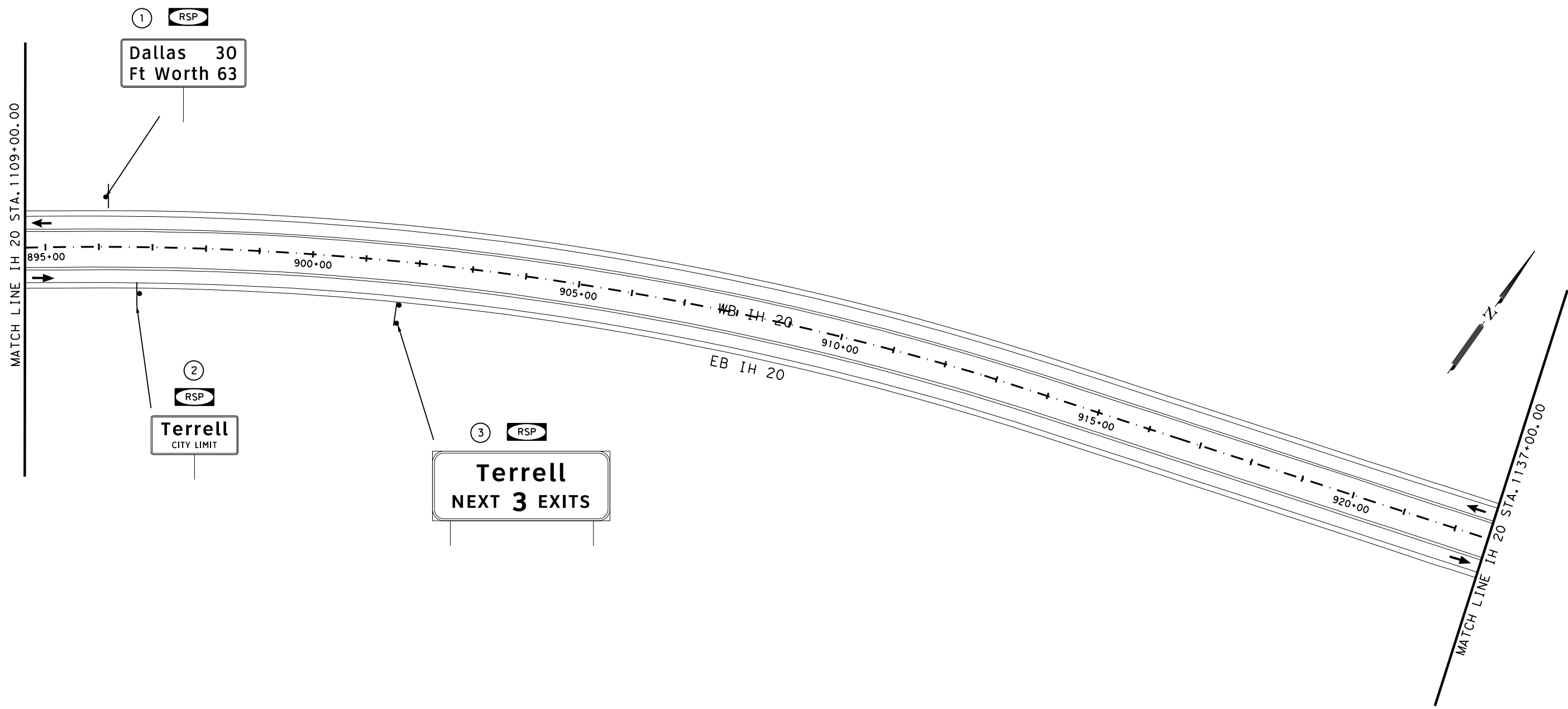

SIGNING LEGEND

- (E) EXISTING SIGN TO REMAIN
- (3) SIGN TO BE INSTALLED
- RSA REMOVE SMALL SIGN ASSEMBLY
- RLA-1 REMOVE LARGE GROUND ASSEMBLY
- RSP REPLACE SMALL SIGN PANEL
- RLP REPLACE LARGE SIGN PANEL
- ROP REPLACE OVERHEAD PANEL
- ROS-1 REMOVE OVERHEAD STRUCTURE

- * REMOVAL ITEMS THIS SHEET
- (EA) SMALL SIGNS ASSEMBLY
- (EA) OVERHEAD SIGNS
- (EA) LARGE SIGNS ASSEMBLY
- (EA) WALKWAY
- * Removal Quantities are Approximate and Contractor Will be Paid For Actual Work Performed

INSTALL PROPOSED SIGNS
1 FT TO 2 FT BEHIND EXISTING
SIGN LOCATION,
UNLESS OTHERWISE NOTED.

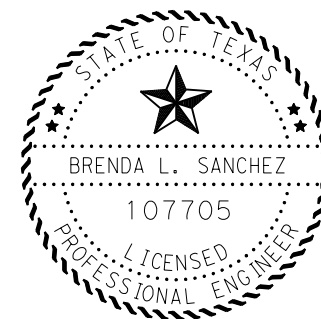

Brenda L Sanchez, P.E. 03/20/23
Signature of Registrar & Date

Texas Department of Transportation
© 2023

**SIGNING LAYOUT
IH 20**

SCALE: 1"=200' SHEET 81 OF 121

DESIGN/CK BLS	FED. RD. DIV. NO. 6	STATE PROJECT NO. (SEE TITLE SHEET)		HIGHWAY NO. IH 20
CHECK BLS	STATE	DISTRICT	COUNTY	SHEET NO.
CHECK MA	TEXAS	DAL	VARIOUS	185
CHECK BA	CONTROL	SECTION	JOB	
	0095	14	033, ETC	

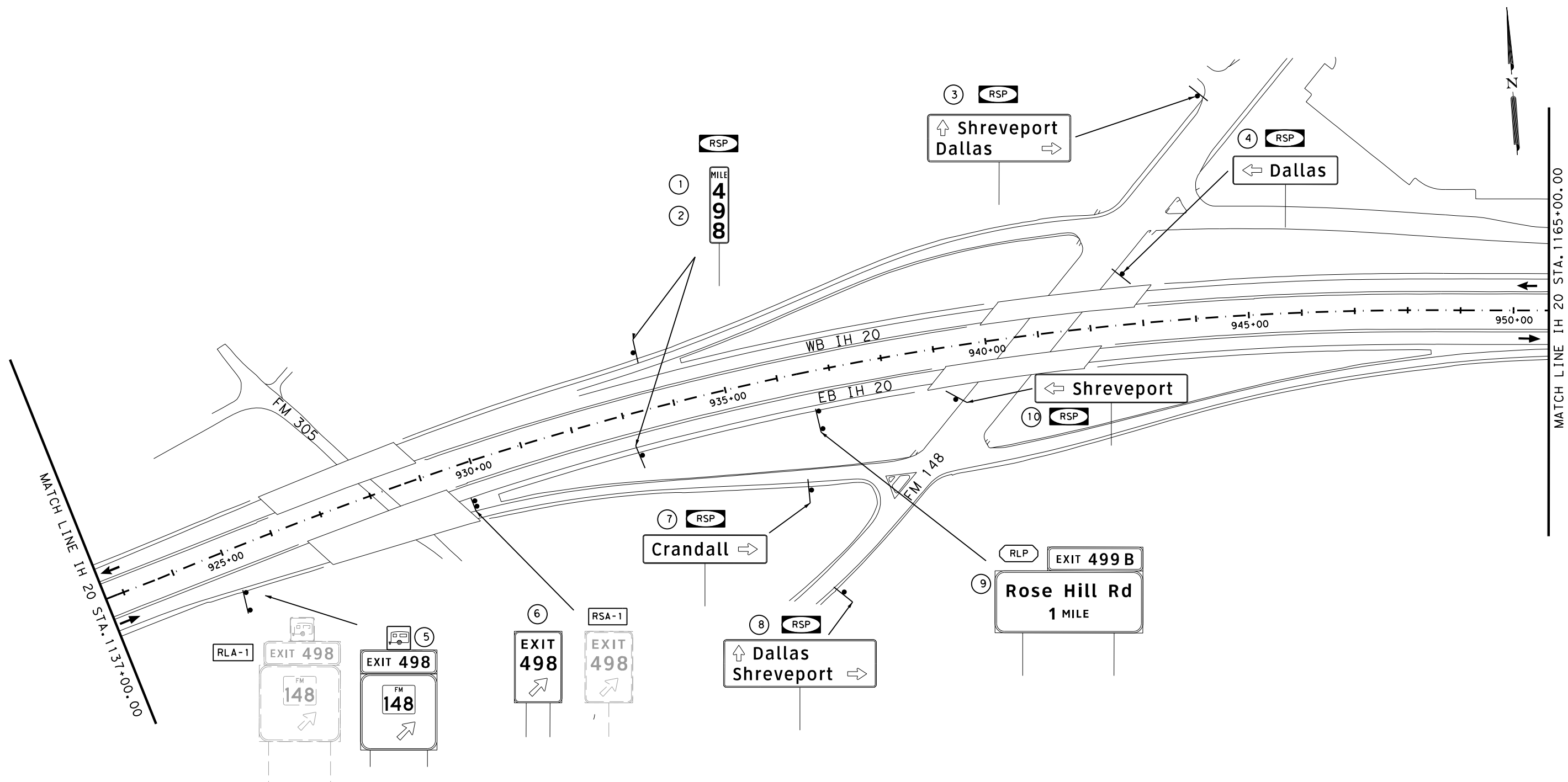

SIGNING LEGEND

- (E) EXISTING SIGN TO REMAIN
- (3) SIGN TO BE INSTALLED
- RSA REMOVE SMALL SIGN ASSEMBLY
- RLA-1 REMOVE LARGE GROUND ASSEMBLY
- RSP REPLACE SMALL SIGN PANEL
- RLP REPLACE LARGE SIGN PANEL
- ROP REPLACE OVERHEAD PANEL
- ROS-1 REMOVE OVERHEAD STRUCTURE

- * REMOVAL ITEMS THIS SHEET
- 1 (EA) SMALL SIGNS ASSEMBLY
 - (EA) OVERHEAD SIGNS
 - 1 (EA) LARGE SIGNS ASSEMBLY
 - (EA) WALKWAY
- * Removal Quantities are Approximate and Contractor Will be Paid For Actual Work Performed

INSTALL PROPOSED SIGNS
1 FT TO 2 FT BEHIND EXISTING
SIGN LOCATION,
UNLESS OTHERWISE NOTED.

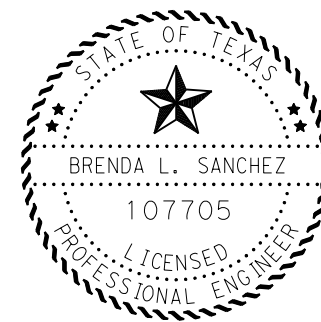

Brenda L. Sanchez, P.E. 03/20/23
Signature of Registrant & Date

Texas Department of Transportation
© 2023

**SIGNING LAYOUT
IH 20**

SCALE: 1"=200' SHEET 82 OF 121

DESIGN/CK BLS	FED. RD. DIV. NO. 6	STATE PROJECT NO. (SEE TITLE SHEET)		HIGHWAY NO. IH 20
CHECK BLS	STATE	DISTRICT DAL	COUNTY VARIOUS	SHEET NO. 186
CHECK MA	TEXAS	SECTION 0095	JOB 14	186
CHECK BA	CONTROL	033, ETC		

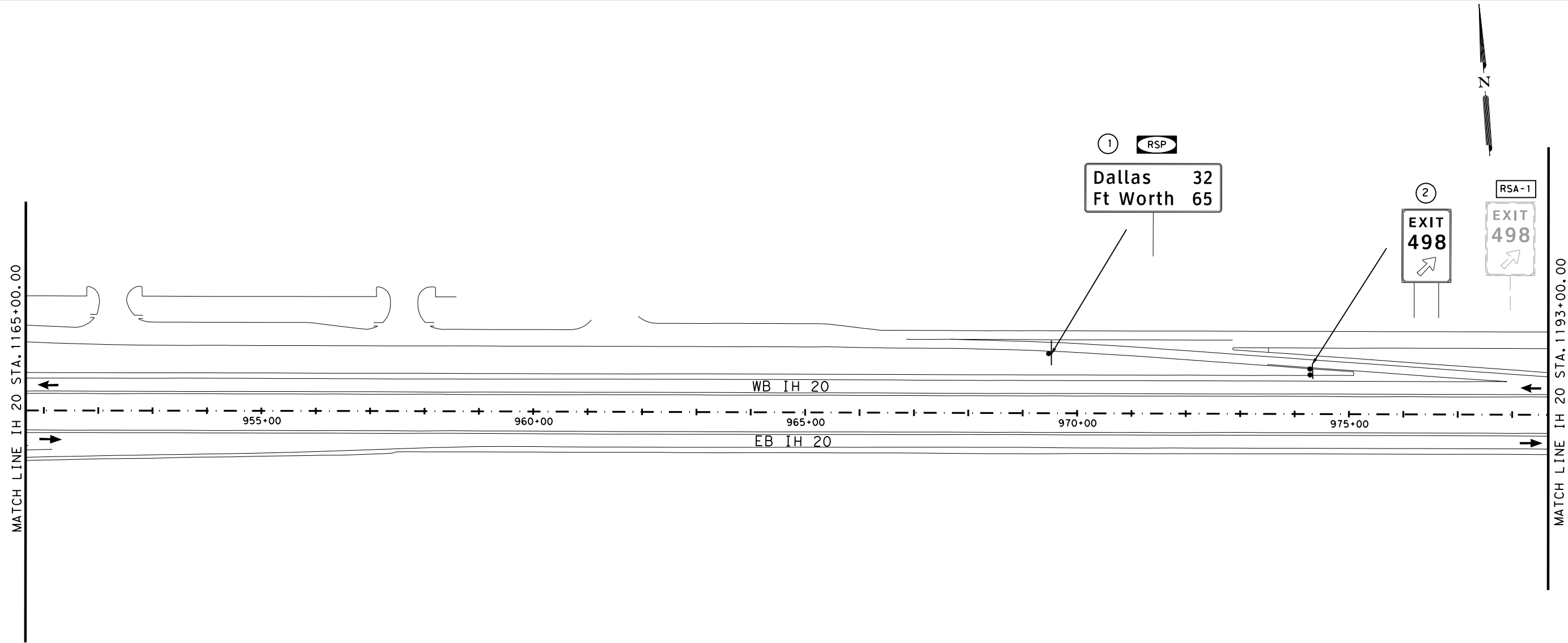

SIGNING LEGEND

- (E) EXISTING SIGN TO REMAIN
- (3) SIGN TO BE INSTALLED
- RSA REMOVE SMALL SIGN ASSEMBLY
- RLA-1 REMOVE LARGE GROUND ASSEMBLY
- RSP REPLACE SMALL SIGN PANEL
- RLP REPLACE LARGE SIGN PANEL
- ROP REPLACE OVERHEAD PANEL
- ROS-1 REMOVE OVERHEAD STRUCTURE

- * REMOVAL ITEMS THIS SHEET
- 1 (EA) SMALL SIGNS ASSEMBLY
 - (EA) OVERHEAD SIGNS
 - (EA) LARGE SIGNS ASSEMBLY
 - (EA) WALKWAY
- * Removal Quantities are Approximate and Contractor Will be Paid For Actual Work Performed

INSTALL PROPOSED SIGNS
1 FT TO 2 FT BEHIND EXISTING
SIGN LOCATION,
UNLESS OTHERWISE NOTED.

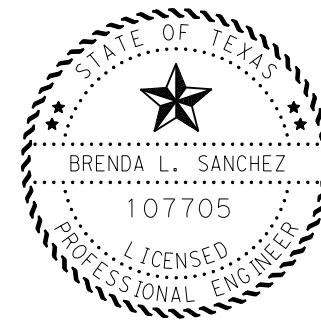

Brenda L Sanchez, P.E. 03/20/23
Signature of Registrant & Date

Texas Department of Transportation
© 2023

**SIGNING LAYOUT
IH 20**

SCALE: 1"=200' SHEET 83 OF 121

DESIGN/CK BLS	FED. RD. DIV. NO. 6	STATE PROJECT NO. (SEE TITLE SHEET)		HIGHWAY NO. IH 20
CHECK BLS	STATE	DISTRICT DAL	COUNTY VARIOUS	SHEET NO. 187
CHECK MA	TEXAS	SECTION 14	JOB 033, ETC	
CHECK BA	0095			

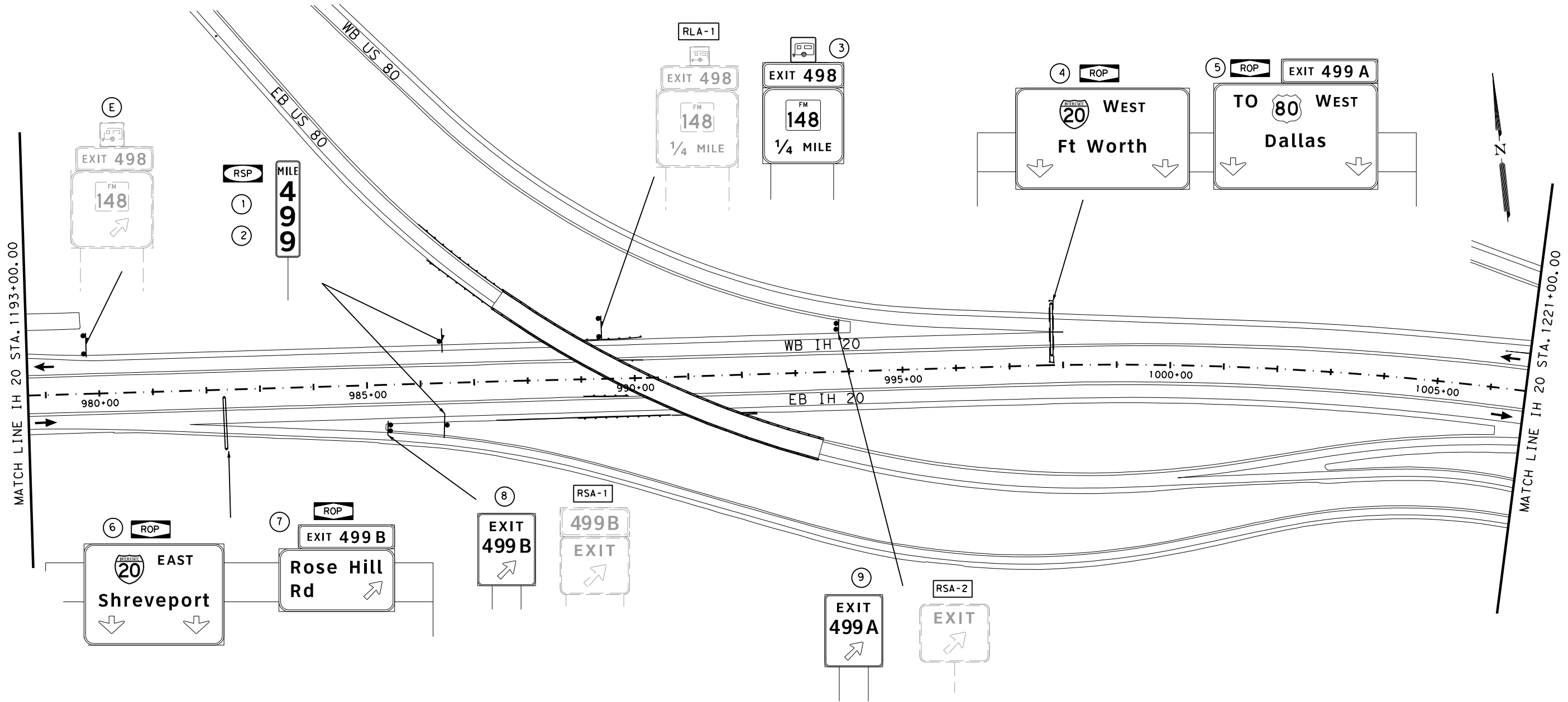

SIGNING LEGEND

- (E) EXISTING SIGN TO REMAIN
- (3) SIGN TO BE INSTALLED
- RSA REMOVE SMALL SIGN ASSEMBLY
- RLA-1 REMOVE LARGE GROUND ASSEMBLY
- RSP REPLACE SMALL SIGN PANEL
- RLP REPLACE LARGE SIGN PANEL
- ROP REPLACE OVERHEAD PANEL
- ROS-1 REMOVE OVERHEAD STRUCTURE

*** REMOVAL ITEMS THIS SHEET**

- 2 (EA) SMALL SIGNS ASSEMBLY
- (EA) OVERHEAD SIGNS
- 1 (EA) LARGE SIGNS ASSEMBLY
- (EA) WALKWAY

* Removal Quantities are Approximate and Contractor Will be Paid For Actual Work Performed

INSTALL PROPOSED SIGNS
1 FT TO 2 FT BEHIND EXISTING
SIGN LOCATION,
UNLESS OTHERWISE NOTED.

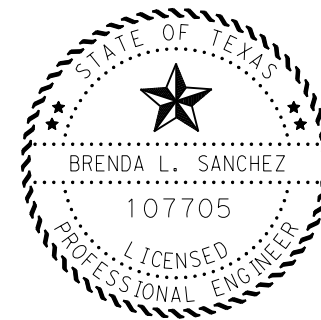

Brenda L Sanchez, P.E. 03/20/23
Signature of Registrar & Date

Texas Department of Transportation
© 2023

**SIGNING LAYOUT
IH 20**

SCALE: 1"=200' SHEET 84 OF 121

DESIGN/CK BLS	FED. RD. DIV. NO. 6	STATE PROJECT NO. (SEE TITLE SHEET)		HIGHWAY NO. IH 20
CHECK BLS	STATE	DISTRICT	COUNTY	SHEET NO.
CHECK MA	TEXAS	DAL	VARIOUS	188
CHECK BA	CONTROL	SECTION	JOB	
	0095	14	033, ETC	

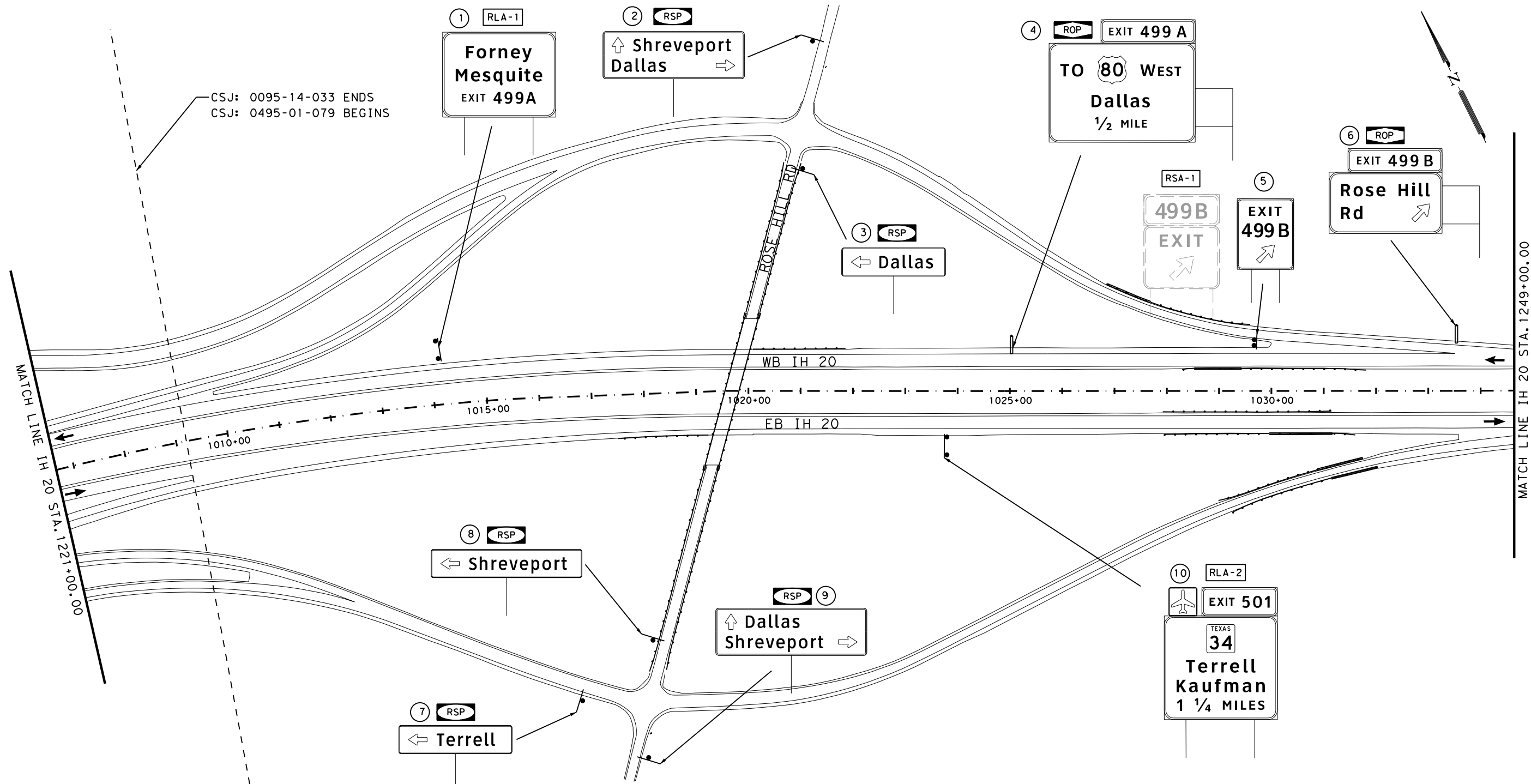

SIGNING LEGEND

- (E) EXISTING SIGN TO REMAIN
 - (3) SIGN TO BE INSTALLED
 - RSA REMOVE SMALL SIGN ASSEMBLY
 - RLA-1 REMOVE LARGE GROUND ASSEMBLY
 - RSP REPLACE SMALL SIGN PANEL
 - RLP REPLACE LARGE SIGN PANEL
 - ROP REPLACE OVERHEAD PANEL
 - ROS-1 REMOVE OVERHEAD STRUCTURE
-
- * REMOVAL ITEMS THIS SHEET
 - 1 (EA) SMALL SIGNS ASSEMBLY
 - 2 (EA) OVERHEAD SIGNS
 - 3 (EA) LARGE SIGNS ASSEMBLY
 - 4 (EA) WALKWAY
-
- * Removal Quantities are Approximate and Contractor Will be Paid For Actual Work Performed

INSTALL PROPOSED SIGNS
1 FT TO 2 FT BEHIND EXISTING
SIGN LOCATION,
UNLESS OTHERWISE NOTED.

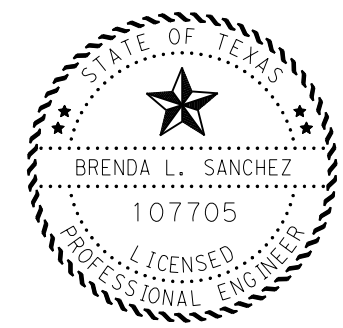

Brenda L Sanchez, P.E. 03/20/23
Signature of Registrant & Date

Texas Department of Transportation
© 2023

**SIGNING LAYOUT
IH 20**

SCALE: 1"=200' SHEET 85 OF 121

DESIGN/CK BLS	FED. RD. DIV. NO. 6	STATE PROJECT NO. (SEE TITLE SHEET)		HIGHWAY NO. IH 20
CHECK BLS	STATE	DISTRICT DAL	COUNTY VARIOUS	SHEET NO. 189
CHECK MA	CONTROL 0095	SECTION 14	JOB 033, ETC	
CHECK BA				

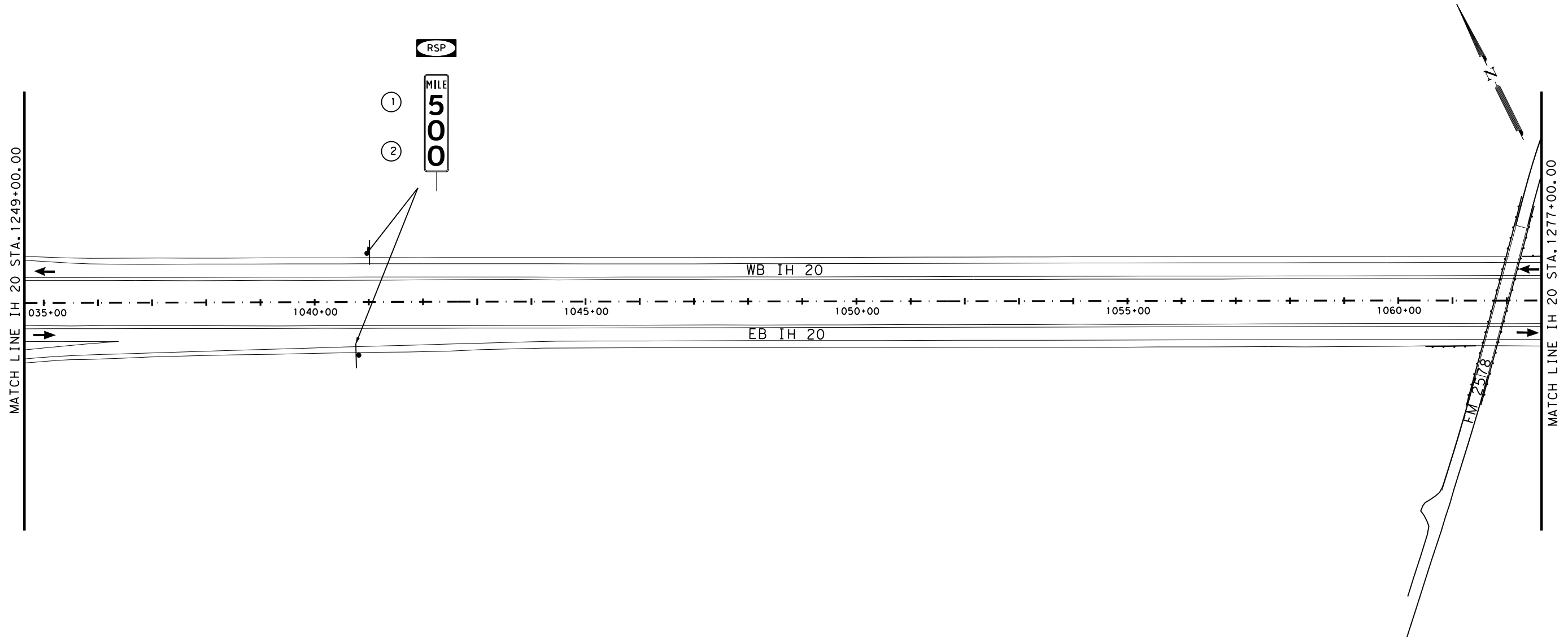

SIGNING LEGEND

- (E) EXISTING SIGN TO REMAIN
- (3) SIGN TO BE INSTALLED
- RSA REMOVE SMALL SIGN ASSEMBLY
- RLA-1 REMOVE LARGE GROUND ASSEMBLY
- RSP REPLACE SMALL SIGN PANEL
- RLP REPLACE LARGE SIGN PANEL
- ROP REPLACE OVERHEAD PANEL
- ROS-1 REMOVE OVERHEAD STRUCTURE

- * REMOVAL ITEMS THIS SHEET
- (EA) SMALL SIGNS ASSEMBLY
 - (EA) OVERHEAD SIGNS
 - (EA) LARGE SIGNS ASSEMBLY
 - (EA) WALKWAY
- * Removal Quantities are Approximate and Contractor Will be Paid For Actual Work Performed

INSTALL PROPOSED SIGNS
1 FT TO 2 FT BEHIND EXISTING
SIGN LOCATION,
UNLESS OTHERWISE NOTED.



Brenda L Sanchez, P.E. 03/20/23
Signature of Registrant & Date

Texas Department of Transportation
© 2023

**SIGNING LAYOUT
IH 20**

SCALE: 1"=200' SHEET 86 OF 121

DESIGN/CK BLS	FED. RD. DIV. NO. 6	STATE PROJECT NO. (SEE TITLE SHEET)		HIGHWAY NO. IH 20
CHECK BLS	STATE	DISTRICT DAL	COUNTY VARIOUS	SHEET NO. 190
CHECK MA	TEXAS	SECTION 14	JOB 033, ETC	
CHECK BA	0095			

MATCH LINE IH 20 STA. 1277+00.00

MATCH LINE IH 20 STA. 1305+00.00

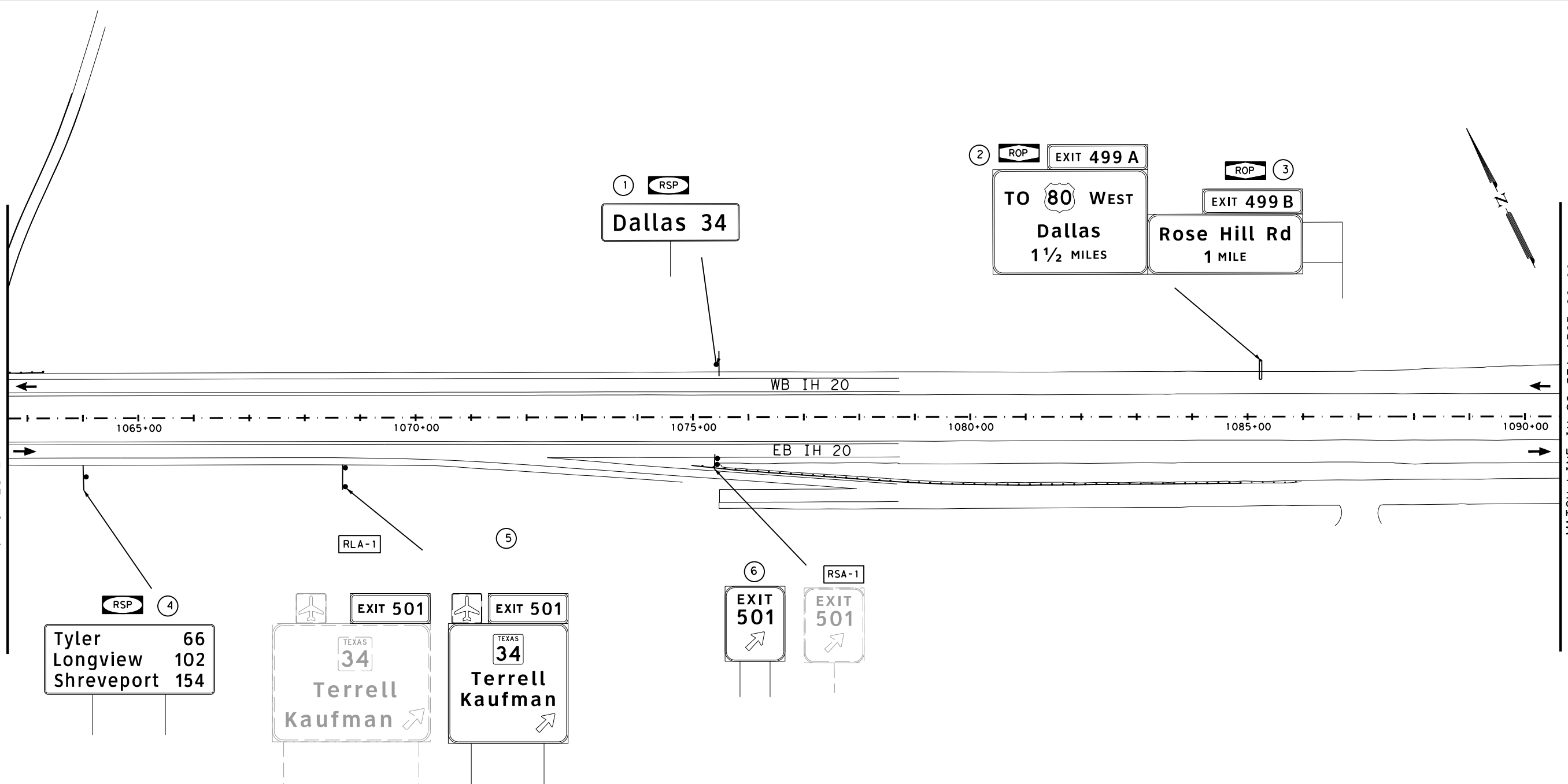

SIGNING LEGEND

- (E) EXISTING SIGN TO REMAIN
- (3) SIGN TO BE INSTALLED
- RSA REMOVE SMALL SIGN ASSEMBLY
- RLA-1 REMOVE LARGE GROUND ASSEMBLY
- RSP REPLACE SMALL SIGN PANEL
- RLP REPLACE LARGE SIGN PANEL
- ROP REPLACE OVERHEAD PANEL
- ROS-1 REMOVE OVERHEAD STRUCTURE

- * REMOVAL ITEMS THIS SHEET
- 1 (EA) SMALL SIGNS ASSEMBLY
 - (EA) OVERHEAD SIGNS
 - 1 (EA) LARGE SIGNS ASSEMBLY
 - (EA) WALKWAY
- * Removal Quantities are Approximate and Contractor Will be Paid For Actual Work Performed

INSTALL PROPOSED SIGNS
1 FT TO 2 FT BEHIND EXISTING
SIGN LOCATION,
UNLESS OTHERWISE NOTED.

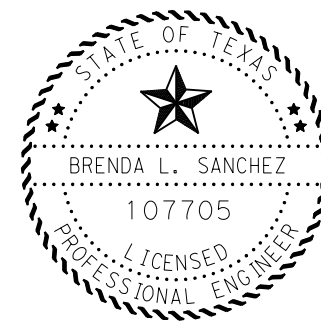

Brenda L. Sanchez, P.E. 03/20/23
Signature of Registrar & Date



**SIGNING LAYOUT
IH 20**

SCALE: 1"=200' SHEET 87 OF 121

DESIGN/CK	FED. RD. DIV. NO.	STATE PROJECT NO.		HIGHWAY NO.
BLS	6	(SEE TITLE SHEET)		IH 20
CHECK	STATE	DISTRICT	COUNTY	SHEET NO.
BLS	TEXAS	DAL	VARIOUS	191
CHECK	CONTROL	SECTION	JOB	
BA	0095	14	033, ETC	

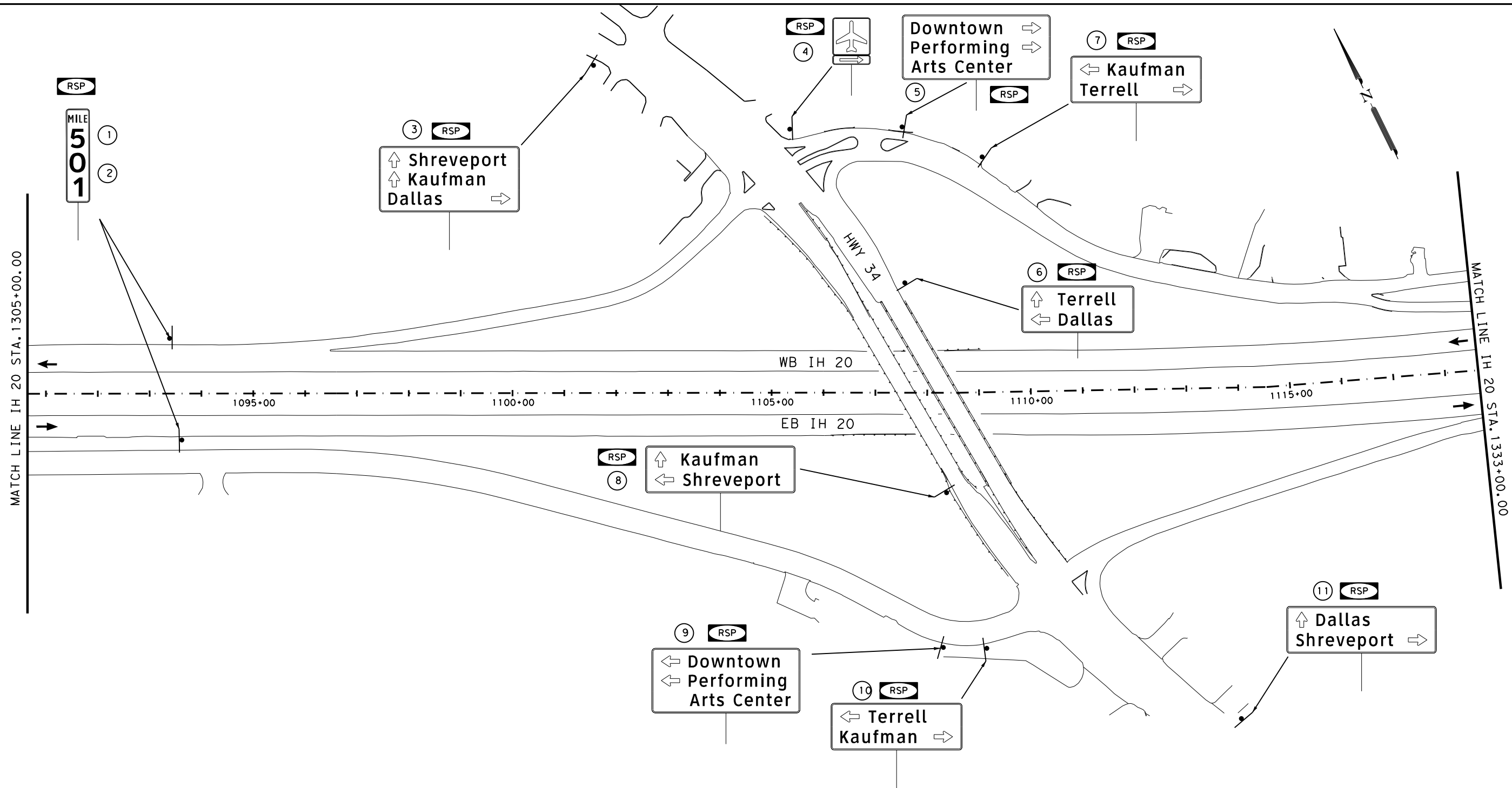

SIGNING LEGEND

- (E) EXISTING SIGN TO REMAIN
- (3) SIGN TO BE INSTALLED
- RSA REMOVE SMALL SIGN ASSEMBLY
- RLA-1 REMOVE LARGE GROUND ASSEMBLY
- RSP REPLACE SMALL SIGN PANEL
- RLP REPLACE LARGE SIGN PANEL
- ROP REPLACE OVERHEAD PANEL
- ROS-1 REMOVE OVERHEAD STRUCTURE

- * REMOVAL ITEMS THIS SHEET
- (EA) SMALL SIGNS ASSEMBLY
 - (EA) OVERHEAD SIGNS
 - (EA) LARGE SIGNS ASSEMBLY
 - (EA) WALKWAY
- * Removal Quantities are Approximate and Contractor Will be Paid For Actual Work Performed

INSTALL PROPOSED SIGNS
1 FT TO 2 FT BEHIND EXISTING
SIGN LOCATION,
UNLESS OTHERWISE NOTED.

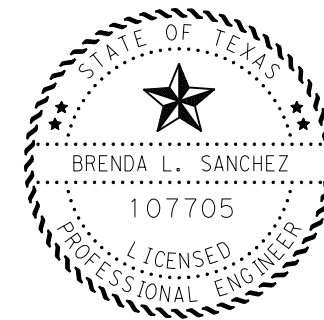

Brenda L Sanchez, P.E. 03/20/23
Signature of Registrant & Date

Texas Department of Transportation
© 2023

**SIGNING LAYOUT
IH 20**

SCALE: 1"=200' SHEET 88 OF 121

DESIGN/CK BLS	FED. RD. DIV. NO. 6	STATE PROJECT NO. (SEE TITLE SHEET)		HIGHWAY NO. IH 20
CHECK BLS	STATE	DISTRICT	COUNTY	SHEET NO.
CHECK MA	TEXAS	DAL	VARIOUS	192
CHECK BA	CONTROL	SECTION	JOB	
	0095	14	033, ETC	

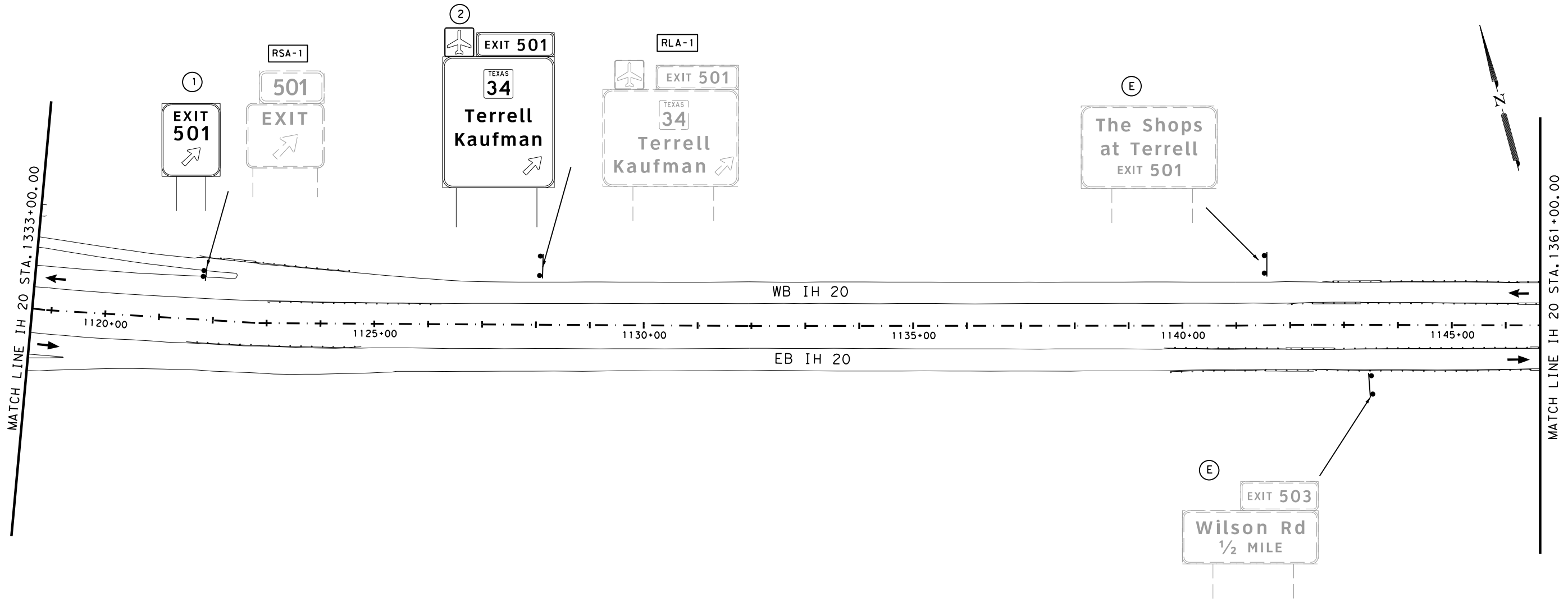

SIGNING LEGEND

- (E) EXISTING SIGN TO REMAIN
- (3) SIGN TO BE INSTALLED
- RSA REMOVE SMALL SIGN ASSEMBLY
- RLA-1 REMOVE LARGE GROUND ASSEMBLY
- RSP REPLACE SMALL SIGN PANEL
- RLP REPLACE LARGE SIGN PANEL
- ROP REPLACE OVERHEAD PANEL
- ROS-1 REMOVE OVERHEAD STRUCTURE

- * REMOVAL ITEMS THIS SHEET
- 1 (EA) SMALL SIGNS ASSEMBLY
 - (EA) OVERHEAD SIGNS
 - 1 (EA) LARGE SIGNS ASSEMBLY
 - (EA) WALKWAY
- * Removal Quantities are Approximate and Contractor Will be Paid For Actual Work Performed

INSTALL PROPOSED SIGNS
1 FT TO 2 FT BEHIND EXISTING
SIGN LOCATION,
UNLESS OTHERWISE NOTED.

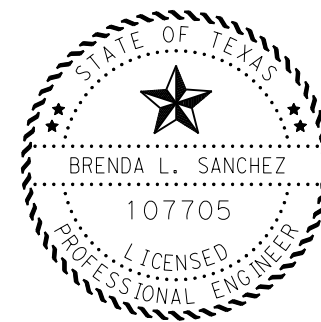

Brenda L Sanchez, P.E. 03/20/23
Signature of Registrar & Date

Texas Department of Transportation
© 2023

**SIGNING LAYOUT
IH 20**

SCALE: 1"=200' SHEET 89 OF 121

DESIGN/CK BLS	FED. RD. DIV. NO. 6	STATE PROJECT NO. (SEE TITLE SHEET)		HIGHWAY NO. IH 20
CHECK BLS	STATE	DISTRICT	COUNTY	SHEET NO.
CHECK MA	TEXAS	DAL	VARIOUS	193
CHECK BA	CONTROL	SECTION	JOB	
	0095	14	033, ETC	

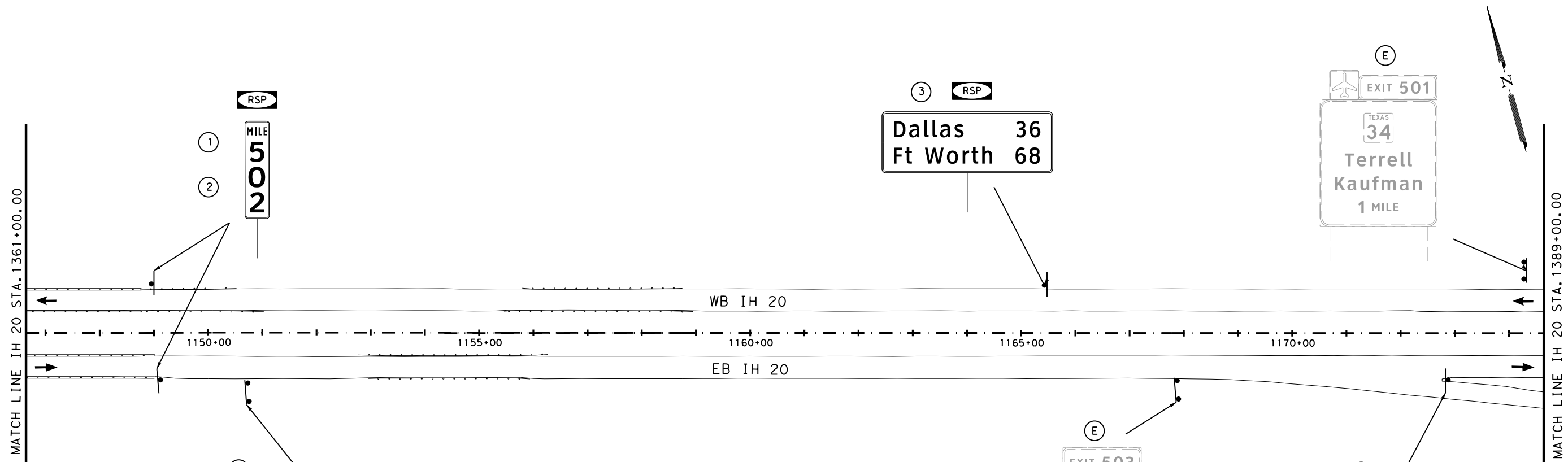

SIGNING LEGEND

- (E) EXISTING SIGN TO REMAIN
- (3) SIGN TO BE INSTALLED
- RSA REMOVE SMALL SIGN ASSEMBLY
- RLA-1 REMOVE LARGE GROUND ASSEMBLY
- RSP REPLACE SMALL SIGN PANEL
- RLP REPLACE LARGE SIGN PANEL
- ROP REPLACE OVERHEAD PANEL
- ROS-1 REMOVE OVERHEAD STRUCTURE

- * REMOVAL ITEMS THIS SHEET
- 1 (EA) SMALL SIGNS ASSEMBLY
 - (EA) OVERHEAD SIGNS
 - (EA) LARGE SIGNS ASSEMBLY
 - (EA) WALKWAY
- * Removal Quantities are Approximate and Contractor Will be Paid For Actual Work Performed

INSTALL PROPOSED SIGNS
1 FT TO 2 FT BEHIND EXISTING
SIGN LOCATION,
UNLESS OTHERWISE NOTED.

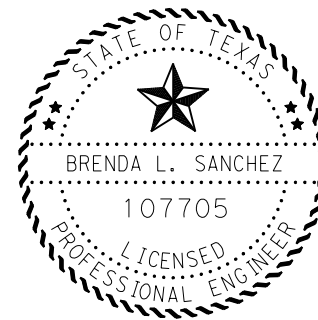

Brenda L. Sanchez, P.E. 03/20/23
Signature of Registrant & Date

 © 2023				
SIGNING LAYOUT IH 20				
SCALE: 1"=200'			SHEET 90 OF 121	
DESIGN/CK BLS	FED. RD. DIV. NO. 6	STATE PROJECT NO. (SEE TITLE SHEET)		HIGHWAY NO. IH 20
CHECK BLS	STATE	DISTRICT	COUNTY	SHEET NO.
CHECK MA	TEXAS	DAL	VARIOUS	194
CHECK BA	CONTROL	SECTION	JOB	
	0095	14	033, ETC	

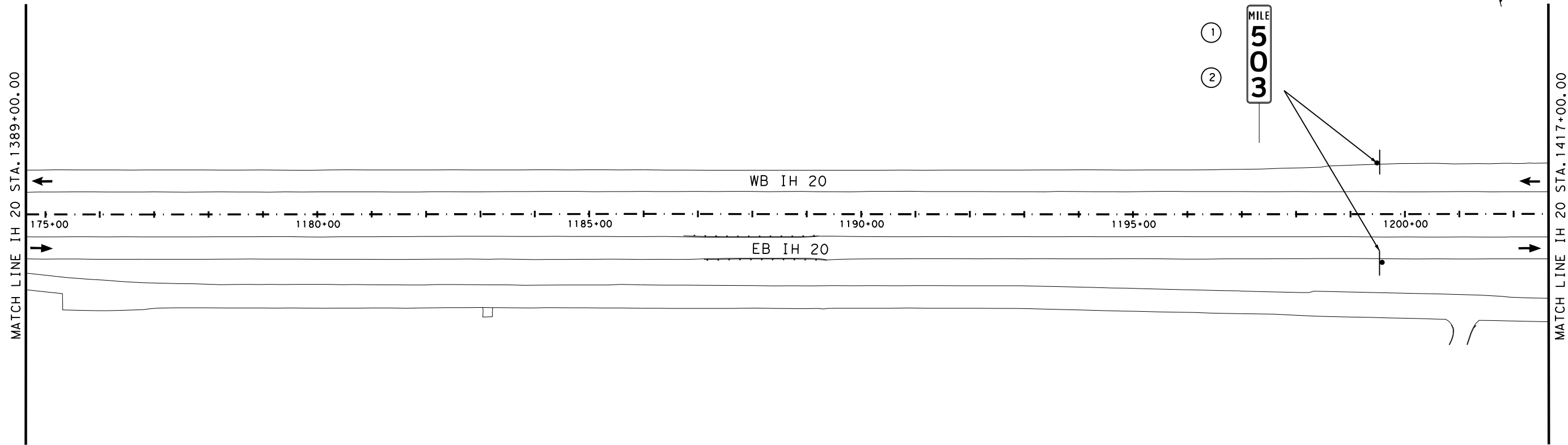

SIGNING LEGEND

- (E) EXISTING SIGN TO REMAIN
- (3) SIGN TO BE INSTALLED
- RSA REMOVE SMALL SIGN ASSEMBLY
- RLA-1 REMOVE LARGE GROUND ASSEMBLY
- RSP REPLACE SMALL SIGN PANEL
- RLP REPLACE LARGE SIGN PANEL
- ROP REPLACE OVERHEAD PANEL
- ROS-1 REMOVE OVERHEAD STRUCTURE

- * REMOVAL ITEMS THIS SHEET
- (EA) SMALL SIGNS ASSEMBLY
- (EA) OVERHEAD SIGNS
- (EA) LARGE SIGNS ASSEMBLY
- (EA) WALKWAY
- * Removal Quantities are Approximate and Contractor Will be Paid For Actual Work Performed

INSTALL PROPOSED SIGNS
1 FT TO 2 FT BEHIND EXISTING
SIGN LOCATION,
UNLESS OTHERWISE NOTED.

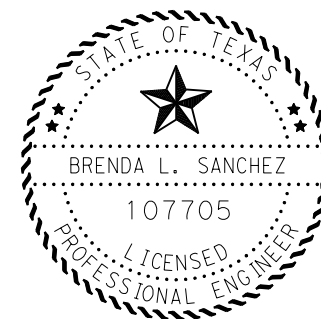

Brenda L Sanchez, P.E. 03/20/23
Signature of Registrar & Date

Texas Department of Transportation
© 2023

**SIGNING LAYOUT
IH 20**

SCALE: 1"=200' SHEET 91 OF 121

DESIGN/CHECK	FED. RD. DIV. NO.	STATE PROJECT NO.		HIGHWAY NO.
BLS	6	(SEE TITLE SHEET)		IH 20
CHECK	STATE	DISTRICT	COUNTY	SHEET NO.
MA	TEXAS	DAL	VARIOUS	195
CHECK	CONTROL	SECTION	JOB	
BA	0095	14	033, ETC	

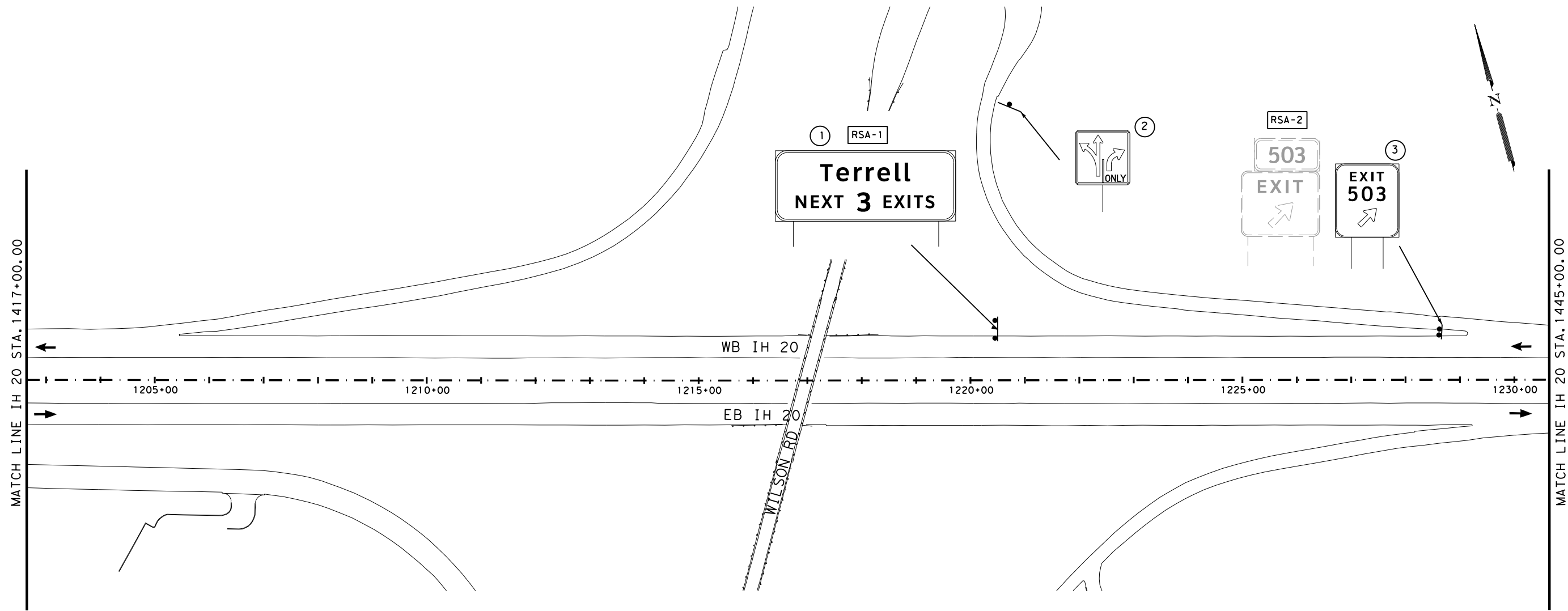

SIGNING LEGEND

- (E) EXISTING SIGN TO REMAIN
- (3) SIGN TO BE INSTALLED
- RSA REMOVE SMALL SIGN ASSEMBLY
- RLA-1 REMOVE LARGE GROUND ASSEMBLY
- RSP REPLACE SMALL SIGN PANEL
- RLP REPLACE LARGE SIGN PANEL
- ROP REPLACE OVERHEAD PANEL
- ROS-1 REMOVE OVERHEAD STRUCTURE

- * REMOVAL ITEMS THIS SHEET
- 2 (EA) SMALL SIGNS ASSEMBLY
 - (EA) OVERHEAD SIGNS
 - (EA) LARGE SIGNS ASSEMBLY
 - (EA) WALKWAY
- * Removal Quantities are Approximate and Contractor Will be Paid For Actual Work Performed

INSTALL PROPOSED SIGNS
1 FT TO 2 FT BEHIND EXISTING
SIGN LOCATION,
UNLESS OTHERWISE NOTED.

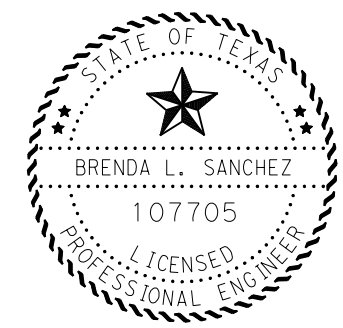

Brenda L Sanchez, P.E. 03/20/23
Signature of Registrant & Date

Texas Department of Transportation
© 2023

**SIGNING LAYOUT
IH 20**

SCALE: 1"=200' SHEET 92 OF 121

DESIGN/CK BLS	FED. RD. DIV. NO. 6	STATE PROJECT NO. (SEE TITLE SHEET)		HIGHWAY NO. IH 20
CHECK BLS	STATE	DISTRICT DAL	COUNTY VARIOUS	SHEET NO. 196
CHECK MA	TEXAS	SECTION 14	JOB 033, ETC	
CHECK BA	CONTROL 0095			

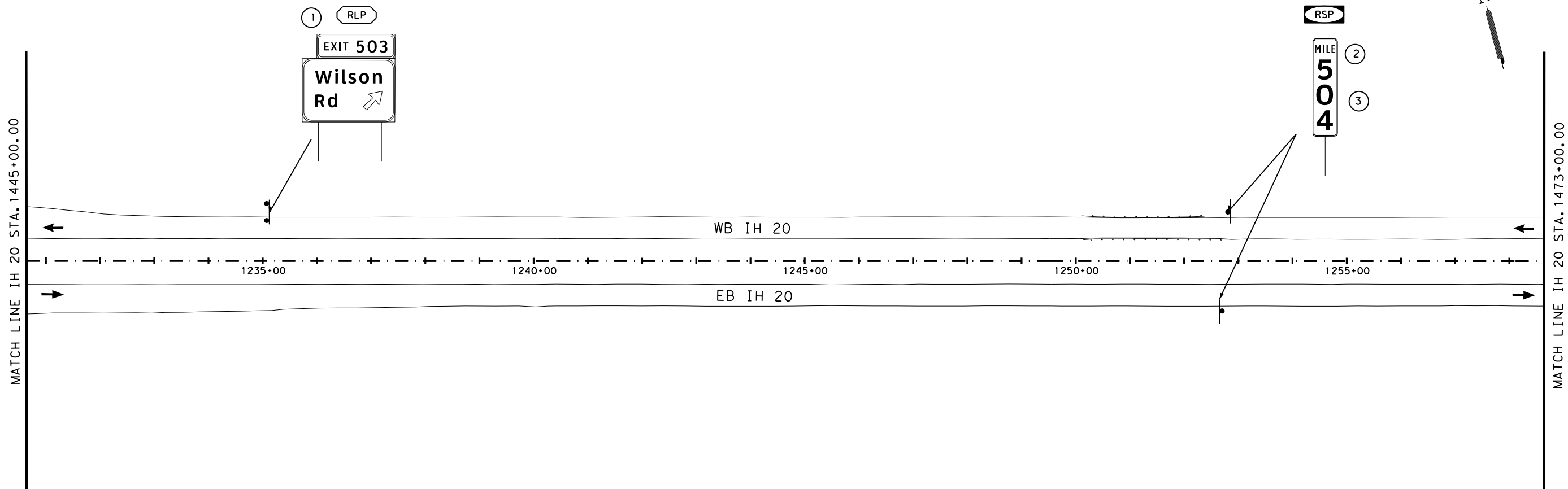

SIGNING LEGEND

- (E) EXISTING SIGN TO REMAIN
 - (3) SIGN TO BE INSTALLED
 - RSA REMOVE SMALL SIGN ASSEMBLY
 - RLA-1 REMOVE LARGE GROUND ASSEMBLY
 - RSP REPLACE SMALL SIGN PANEL
 - RLP REPLACE LARGE SIGN PANEL
 - ROP REPLACE OVERHEAD PANEL
 - ROS-1 REMOVE OVERHEAD STRUCTURE
-
- * REMOVAL ITEMS THIS SHEET
 - (EA) SMALL SIGNS ASSEMBLY
 - (EA) OVERHEAD SIGNS
 - (EA) LARGE SIGNS ASSEMBLY
 - (EA) WALKWAY
 - * Removal Quantities are Approximate and Contractor Will be Paid For Actual Work Performed

INSTALL PROPOSED SIGNS
1 FT TO 2 FT BEHIND EXISTING
SIGN LOCATION,
UNLESS OTHERWISE NOTED.



Brenda L Sanchez, P.E. 03/20/23
Signature of Registrar & Date

Texas Department of Transportation
© 2023

**SIGNING LAYOUT
IH 20**

SCALE: 1"=200' SHEET 93 OF 121

DESIGN/CK BLS	FED. RD. DIV. NO. 6	STATE PROJECT NO. (SEE TITLE SHEET)		HIGHWAY NO. IH 20
CHECK BLS	STATE	DISTRICT DAL	COUNTY VARIOUS	SHEET NO. 197
CHECK MA	TEXAS	SECTION 14	JOB 033, ETC	
CHECK BA	CONTROL 0095			

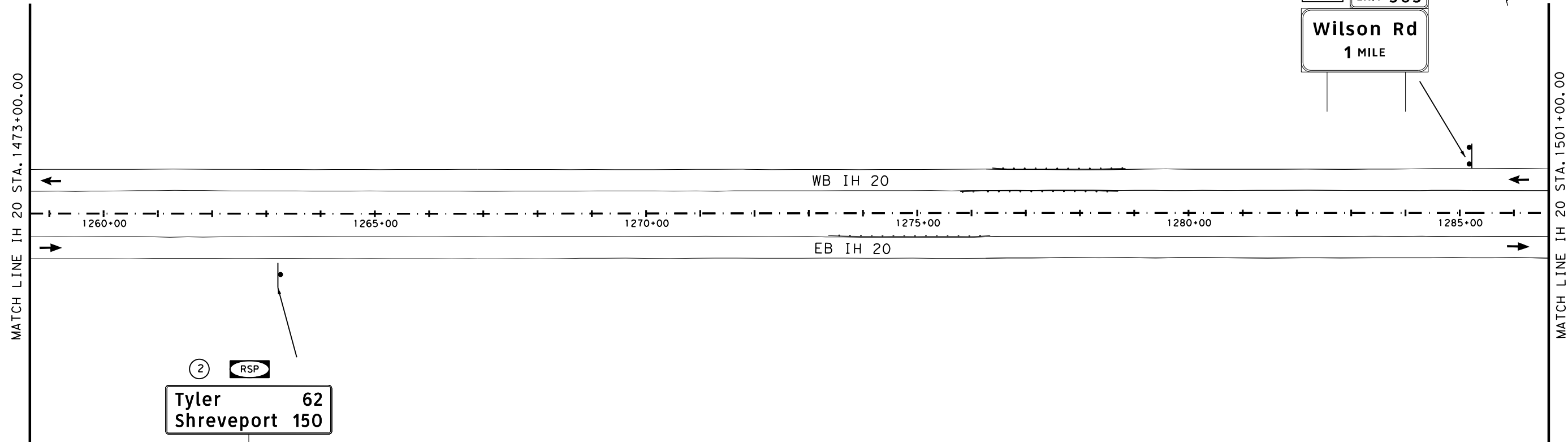

SIGNING LEGEND

- (E) EXISTING SIGN TO REMAIN
- (3) SIGN TO BE INSTALLED
- RSA REMOVE SMALL SIGN ASSEMBLY
- RLA-1 REMOVE LARGE GROUND ASSEMBLY
- RSP REPLACE SMALL SIGN PANEL
- RLP REPLACE LARGE SIGN PANEL
- ROP REPLACE OVERHEAD PANEL
- ROS-1 REMOVE OVERHEAD STRUCTURE

- * REMOVAL ITEMS THIS SHEET
- (EA) SMALL SIGNS ASSEMBLY
- (EA) OVERHEAD SIGNS
- 1 (EA) LARGE SIGNS ASSEMBLY
- (EA) WALKWAY
- * Removal Quantities are Approximate and Contractor Will be Paid For Actual Work Performed

INSTALL PROPOSED SIGNS
1 FT TO 2 FT BEHIND EXISTING
SIGN LOCATION,
UNLESS OTHERWISE NOTED.

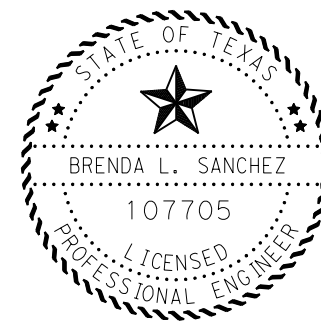

Brenda L. Sanchez, P.E. 03/20/23
Signature of Registrar & Date

Texas Department of Transportation
© 2023

**SIGNING LAYOUT
IH 20**

SCALE: 1"=200' SHEET 94 OF 121

DESIGN/CK BLS	FED. RD. DIV. NO. 6	STATE PROJECT NO. (SEE TITLE SHEET)		HIGHWAY NO. IH 20
CHECK BLS	STATE	DISTRICT	COUNTY	SHEET NO.
CHECK MA	TEXAS	DAL	VARIOUS	198
CHECK BA	CONTROL	SECTION	JOB	
	0095	14	033, ETC	

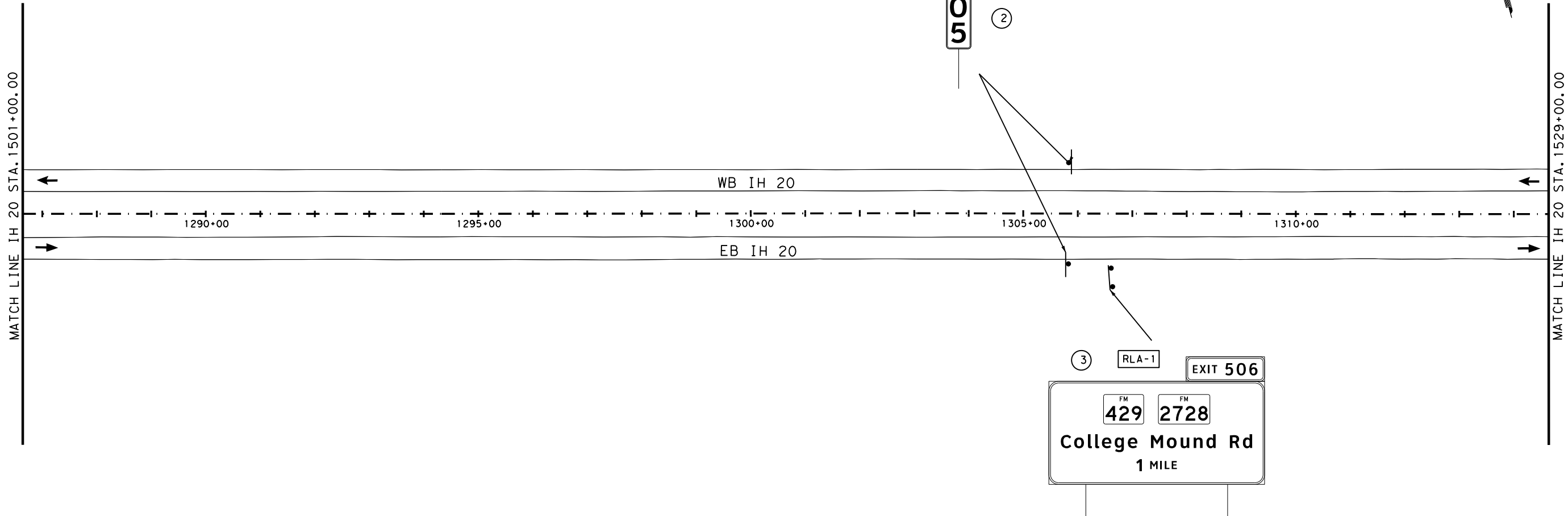

SIGNING LEGEND

- (E) EXISTING SIGN TO REMAIN
- (3) SIGN TO BE INSTALLED
- RSA REMOVE SMALL SIGN ASSEMBLY
- RLA-1 REMOVE LARGE GROUND ASSEMBLY
- RSP REPLACE SMALL SIGN PANEL
- RLP REPLACE LARGE SIGN PANEL
- ROP REPLACE OVERHEAD PANEL
- ROS-1 REMOVE OVERHEAD STRUCTURE

- * REMOVAL ITEMS THIS SHEET
- (EA) SMALL SIGNS ASSEMBLY
 - (EA) OVERHEAD SIGNS
 - 1 (EA) LARGE SIGNS ASSEMBLY
 - (EA) WALKWAY
- * Removal Quantities are Approximate and Contractor Will be Paid For Actual Work Performed

INSTALL PROPOSED SIGNS
1 FT TO 2 FT BEHIND EXISTING
SIGN LOCATION,
UNLESS OTHERWISE NOTED.

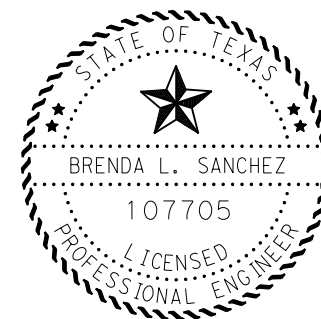

Brenda L Sanchez, P.E. 03/20/23
Signature of Registrar & Date

Texas Department of Transportation
© 2023

**SIGNING LAYOUT
IH 20**

SCALE: 1"=200' SHEET 95 OF 121

DESIGN/CK BLS	FED. RD. DIV. NO. 6	STATE PROJECT NO. (SEE TITLE SHEET)		HIGHWAY NO. IH 20
CHECK BLS	STATE	DISTRICT DAL	COUNTY VARIOUS	SHEET NO. 199
CHECK MA	TEXAS	SECTION CONTROL	JOB 033, ETC	
CHECK BA	0095	14		

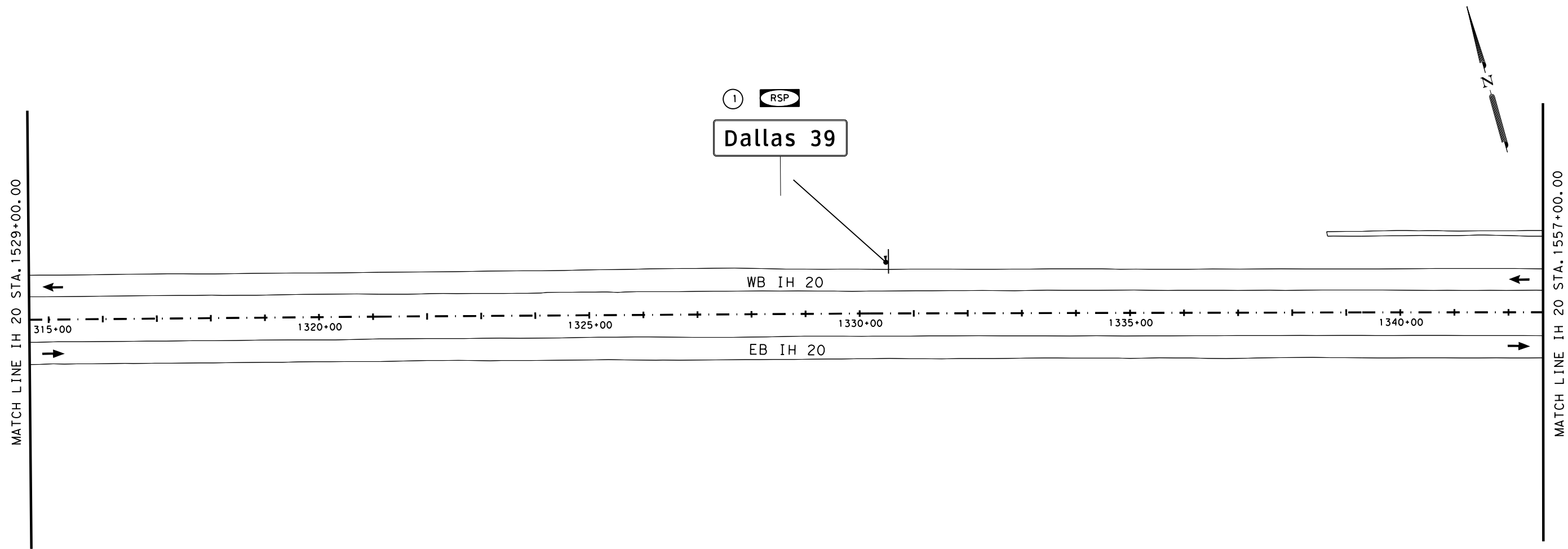

SIGNING LEGEND

- (E) EXISTING SIGN TO REMAIN
- (3) SIGN TO BE INSTALLED
- RSA REMOVE SMALL SIGN ASSEMBLY
- RLA-1 REMOVE LARGE GROUND ASSEMBLY
- RSP REPLACE SMALL SIGN PANEL
- RLP REPLACE LARGE SIGN PANEL
- ROP REPLACE OVERHEAD PANEL
- ROS-1 REMOVE OVERHEAD STRUCTURE

- * REMOVAL ITEMS THIS SHEET
- (EA) SMALL SIGNS ASSEMBLY
 - (EA) OVERHEAD SIGNS
 - (EA) LARGE SIGNS ASSEMBLY
 - (EA) WALKWAY
- * Removal Quantities are Approximate and Contractor Will be Paid For Actual Work Performed

INSTALL PROPOSED SIGNS
1 FT TO 2 FT BEHIND EXISTING
SIGN LOCATION,
UNLESS OTHERWISE NOTED.

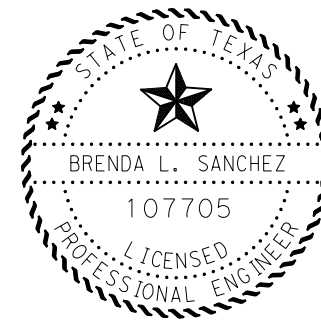

Brenda L Sanchez, P.E. 03/20/23
Signature of Registrar & Date

 Texas Department of Transportation © 2023			
SIGNING LAYOUT IH 20			
SCALE: 1"=200'			SHEET 96 OF 121
DESIGN/CK BLS	FED. RD. DIV. NO. 6	STATE PROJECT NO. (SEE TITLE SHEET)	
CHECK BLS	STATE	DISTRICT DAL	COUNTY VARIOUS
CHECK MA	TEXAS	SECTION JOB	
CHECK BA	CONTROL 0095	SECTION 14	JOB 033, ETC
			HIGHWAY NO. IH 20 SHEET NO. 200

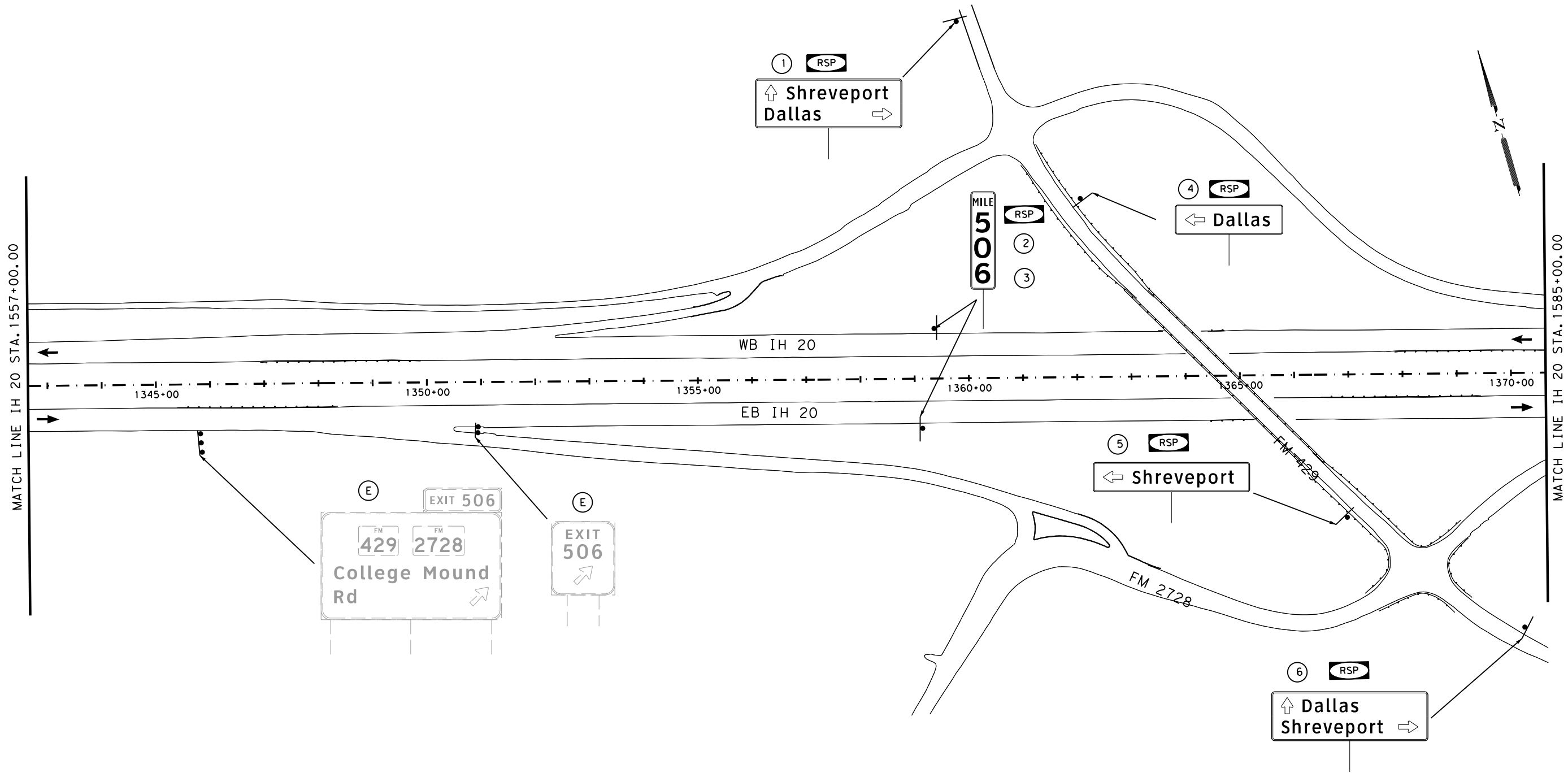

SIGNING LEGEND

- (E) EXISTING SIGN TO REMAIN
 - (3) SIGN TO BE INSTALLED
 - RSA REMOVE SMALL SIGN ASSEMBLY
 - RLA-1 REMOVE LARGE GROUND ASSEMBLY
 - RSP REPLACE SMALL SIGN PANEL
 - RLP REPLACE LARGE SIGN PANEL
 - ROP REPLACE OVERHEAD PANEL
 - ROS-1 REMOVE OVERHEAD STRUCTURE
-
- * REMOVAL ITEMS THIS SHEET
 - (EA) SMALL SIGNS ASSEMBLY
 - (EA) OVERHEAD SIGNS
 - (EA) LARGE SIGNS ASSEMBLY
 - (EA) WALKWAY
-
- * Removal Quantities are Approximate and Contractor Will be Paid For Actual Work Performed

INSTALL PROPOSED SIGNS
1 FT TO 2 FT BEHIND EXISTING
SIGN LOCATION,
UNLESS OTHERWISE NOTED.

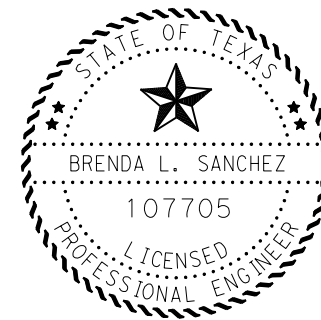

Brenda L Sanchez, P.E. 03/20/23
Signature of Registrar & Date



**SIGNING LAYOUT
IH 20**

SCALE: 1"=200' SHEET 97 OF 121

DESIGN/CK BLS	FED. RD. DIV. NO. 6	STATE PROJECT NO. (SEE TITLE SHEET)		HIGHWAY NO. IH 20
CHECK BLS	STATE	DISTRICT DAL	COUNTY VARIOUS	SHEET NO. 201
CHECK MA	CONTROL	SECTION	JOB	
CHECK BA	0095	14	033, ETC	

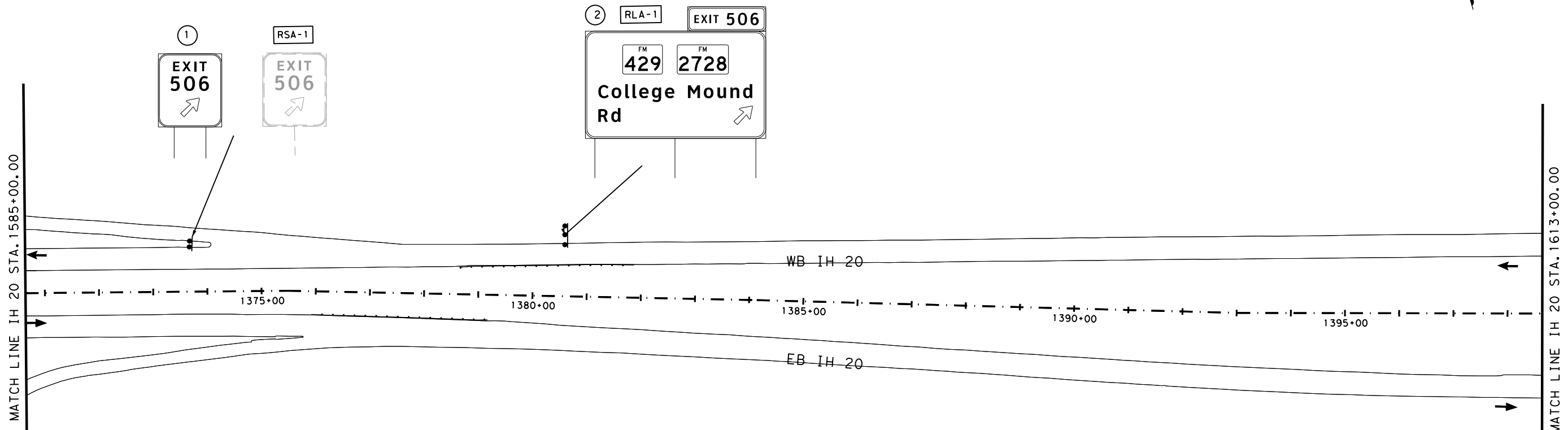

SIGNING LEGEND

- (E) EXISTING SIGN TO REMAIN
- (3) SIGN TO BE INSTALLED
- RSA REMOVE SMALL SIGN ASSEMBLY
- RLA-1 REMOVE LARGE GROUND ASSEMBLY
- RSP REPLACE SMALL SIGN PANEL
- RLP REPLACE LARGE SIGN PANEL
- ROP REPLACE OVERHEAD PANEL
- ROS-1 REMOVE OVERHEAD STRUCTURE

- * REMOVAL ITEMS THIS SHEET
- 1 (EA) SMALL SIGNS ASSEMBLY
 - 1 (EA) OVERHEAD SIGNS
 - 1 (EA) LARGE SIGNS ASSEMBLY
 - 1 (EA) WALKWAY
- * Removal Quantities are Approximate and Contractor Will be Paid For Actual Work Performed

INSTALL PROPOSED SIGNS
1 FT TO 2 FT BEHIND EXISTING
SIGN LOCATION,
UNLESS OTHERWISE NOTED.

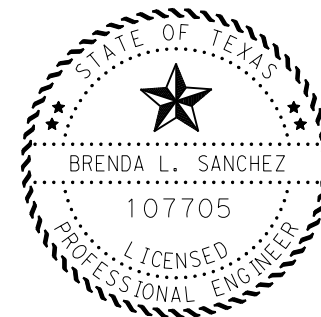

Brenda L. Sanchez, P.E. 03/20/23
Signature of Registrar & Date

Texas Department of Transportation
© 2023

**SIGNING LAYOUT
IH 20**

SCALE: 1"=200' SHEET 98 OF 121

DESIGN/CK BLS	FED. RD. DIV. NO. 6	STATE PROJECT NO. (SEE TITLE SHEET)		HIGHWAY NO. IH 20
CHECK BLS	STATE	DISTRICT DAL	COUNTY VARIOUS	SHEET NO. 202
CHECK MA	TEXAS	SECTION CONTROL	JOB 033, ETC	
CHECK BA	0095	14		

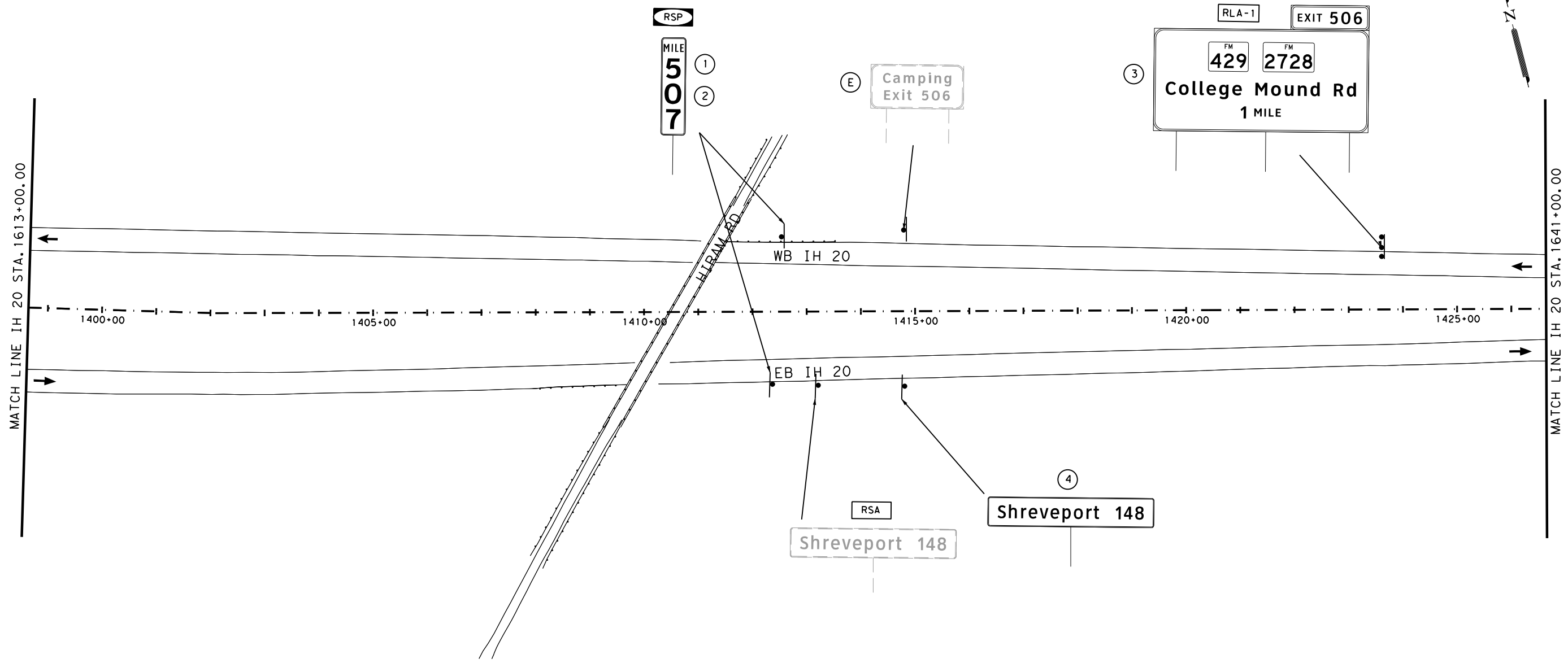

SIGNING LEGEND

- (E) EXISTING SIGN TO REMAIN
- (3) SIGN TO BE INSTALLED
- RSA REMOVE SMALL SIGN ASSEMBLY
- RLA-1 REMOVE LARGE GROUND ASSEMBLY
- RSP REPLACE SMALL SIGN PANEL
- RLP REPLACE LARGE SIGN PANEL
- ROP REPLACE OVERHEAD PANEL
- ROS-1 REMOVE OVERHEAD STRUCTURE

- * REMOVAL ITEMS THIS SHEET
- 1 (EA) SMALL SIGNS ASSEMBLY
 - (EA) OVERHEAD SIGNS
 - 1 (EA) LARGE SIGNS ASSEMBLY
 - (EA) WALKWAY
- * Removal Quantities are Approximate and Contractor Will be Paid For Actual Work Performed

INSTALL PROPOSED SIGNS
1 FT TO 2 FT BEHIND EXISTING
SIGN LOCATION,
UNLESS OTHERWISE NOTED.



Brenda L Sanchez, P.E. 03/20/23
Signature of Registrar & Date

Texas Department of Transportation
© 2023

**SIGNING LAYOUT
IH 20**

SCALE: 1"=200' SHEET 99 OF 121

DESIGN/CK BLS	FED. RD. DIV. NO. 6	STATE PROJECT NO. (SEE TITLE SHEET)		HIGHWAY NO. IH 20
CHECK BLS	STATE	DISTRICT DAL	COUNTY VARIOUS	SHEET NO. 203
CHECK MA	TEXAS	SECTION CONTROL	JOB 033, ETC	
CHECK BA	0095	14		

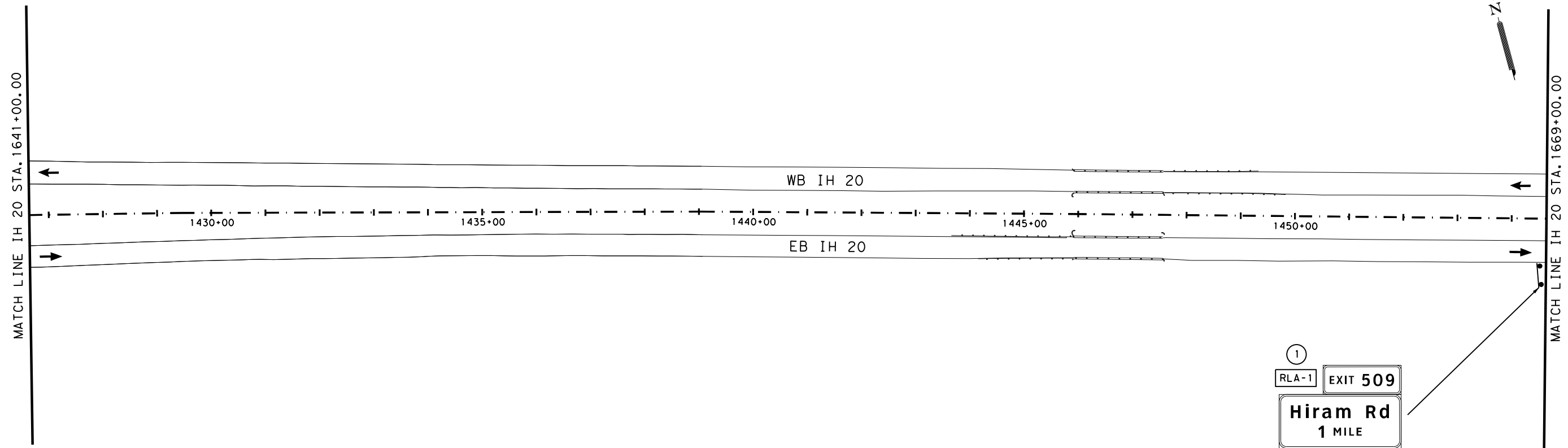

SIGNING LEGEND

- (E) EXISTING SIGN TO REMAIN
- (3) SIGN TO BE INSTALLED
- RSA REMOVE SMALL SIGN ASSEMBLY
- RLA-1 REMOVE LARGE GROUND ASSEMBLY
- RSP REPLACE SMALL SIGN PANEL
- RLP REPLACE LARGE SIGN PANEL
- ROP REPLACE OVERHEAD PANEL
- ROS-1 REMOVE OVERHEAD STRUCTURE

- * REMOVAL ITEMS THIS SHEET
- (EA) SMALL SIGNS ASSEMBLY
- (EA) OVERHEAD SIGNS
- 1 (EA) LARGE SIGNS ASSEMBLY
- (EA) WALKWAY
- * Removal Quantities are Approximate and Contractor Will be Paid For Actual Work Performed

INSTALL PROPOSED SIGNS
1 FT TO 2 FT BEHIND EXISTING
SIGN LOCATION,
UNLESS OTHERWISE NOTED.

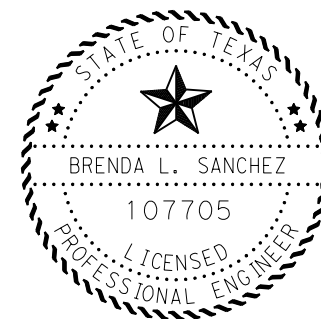

Brenda L Sanchez, P.E. 03/20/23
Signature of Registrar & Date

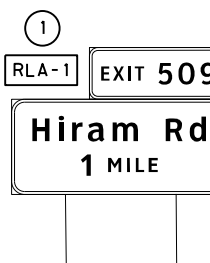

 Texas Department of Transportation © 2023				
SIGNING LAYOUT IH 20				
SCALE: 1"=200'			SHEET 100 OF 121	
DESIGN/CK	FED. RD. DIV. NO.	STATE PROJECT NO.		HIGHWAY NO.
BLS	6	(SEE TITLE SHEET)		IH 20
CHECK	STATE	DISTRICT	COUNTY	SHEET NO.
BLS	TEXAS	DAL	VARIOUS	204
CHECK	CONTROL	SECTION	JOB	
BA	0095	14	033, ETC	

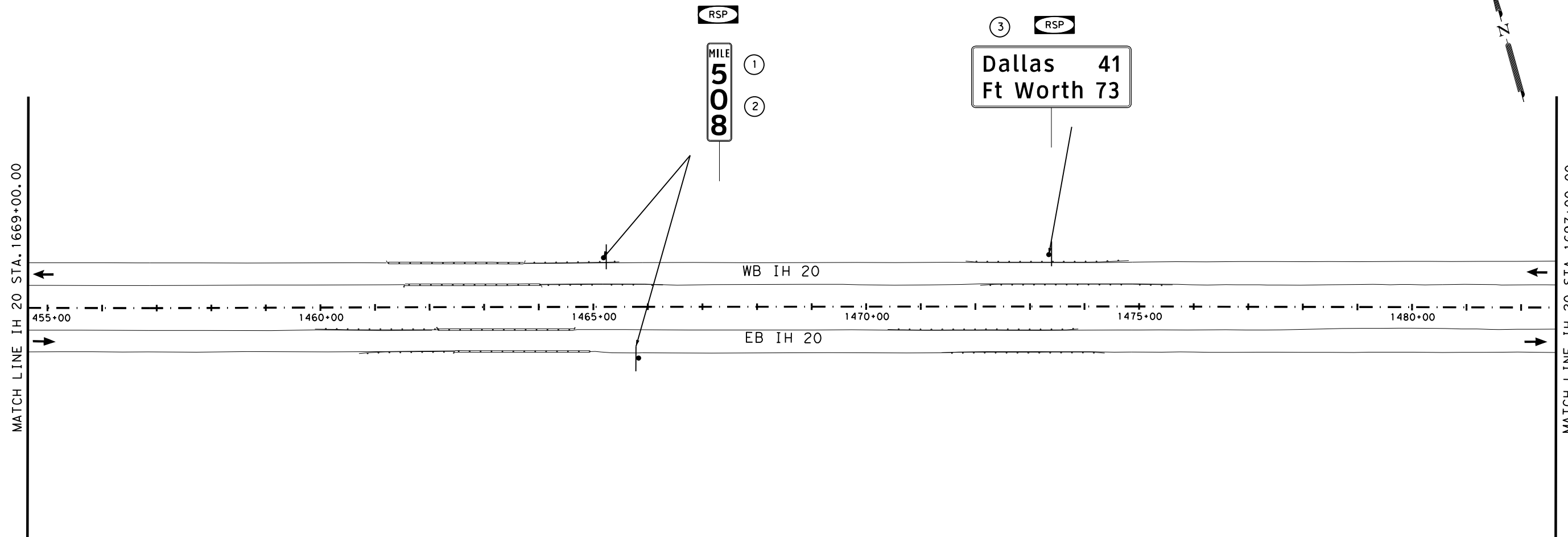

SIGNING LEGEND

- (E) EXISTING SIGN TO REMAIN
- (3) SIGN TO BE INSTALLED
- RSA REMOVE SMALL SIGN ASSEMBLY
- RLA-1 REMOVE LARGE GROUND ASSEMBLY
- RSP REPLACE SMALL SIGN PANEL
- RLP REPLACE LARGE SIGN PANEL
- ROP REPLACE OVERHEAD PANEL
- ROS-1 REMOVE OVERHEAD STRUCTURE

- * REMOVAL ITEMS THIS SHEET
- (EA) SMALL SIGNS ASSEMBLY
 - (EA) OVERHEAD SIGNS
 - (EA) LARGE SIGNS ASSEMBLY
 - (EA) WALKWAY
- * Removal Quantities are Approximate and Contractor Will be Paid For Actual Work Performed

INSTALL PROPOSED SIGNS
1 FT TO 2 FT BEHIND EXISTING
SIGN LOCATION,
UNLESS OTHERWISE NOTED.

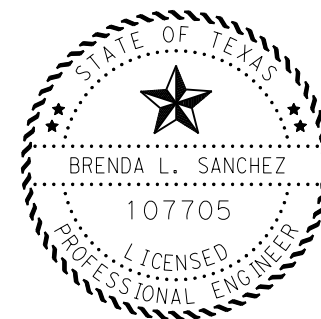

Brenda L Sanchez, P.E. 03/20/23
Signature of Registrar & Date

Texas Department of Transportation
© 2023

**SIGNING LAYOUT
IH 20**

SCALE: 1"=200' SHEET 101 OF 121

DESIGN/CHECK	FED. RD. DIV. NO.	STATE PROJECT NO.		HIGHWAY NO.
BLS	6	(SEE TITLE SHEET)		IH 20
CHECK	STATE	DISTRICT	COUNTY	SHEET NO.
BLS	TEXAS	DAL	VARIOUS	205
CHECK	CONTROL	SECTION	JOB	
MA	0095	14	033, ETC	

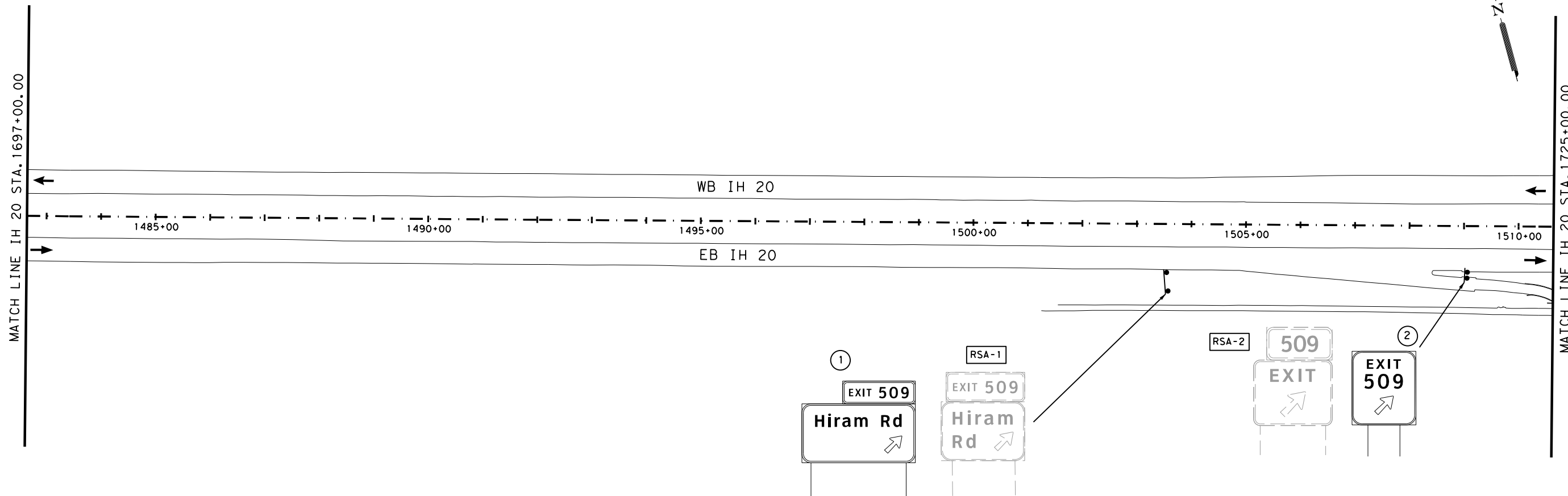

SIGNING LEGEND

- (E) EXISTING SIGN TO REMAIN
- (3) SIGN TO BE INSTALLED
- RSA REMOVE SMALL SIGN ASSEMBLY
- RLA-1 REMOVE LARGE GROUND ASSEMBLY
- RSP REPLACE SMALL SIGN PANEL
- RLP REPLACE LARGE SIGN PANEL
- ROP REPLACE OVERHEAD PANEL
- ROS-1 REMOVE OVERHEAD STRUCTURE

- * REMOVAL ITEMS THIS SHEET
- 2 (EA) SMALL SIGNS ASSEMBLY
- (EA) OVERHEAD SIGNS
- (EA) LARGE SIGNS ASSEMBLY
- (EA) WALKWAY
- * Removal Quantities are Approximate and Contractor Will be Paid For Actual Work Performed

INSTALL PROPOSED SIGNS
1 FT TO 2 FT BEHIND EXISTING
SIGN LOCATION,
UNLESS OTHERWISE NOTED.

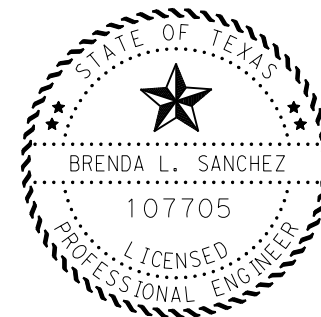

Brenda L. Sanchez, P.E. 03/20/23
Signature of Registrar & Date

Texas Department of Transportation
© 2023

**SIGNING LAYOUT
IH 20**

SCALE: 1"=200' SHEET 102 OF 121

DESIGN/CK BLS	FED. RD. DIV. NO. 6	STATE PROJECT NO. (SEE TITLE SHEET)		HIGHWAY NO. IH 20
CHECK BLS	STATE	DISTRICT DAL	COUNTY VARIOUS	SHEET NO. 206
CHECK MA	CONTROL 0095	SECTION 14	JOB 033, ETC	
CHECK BA				

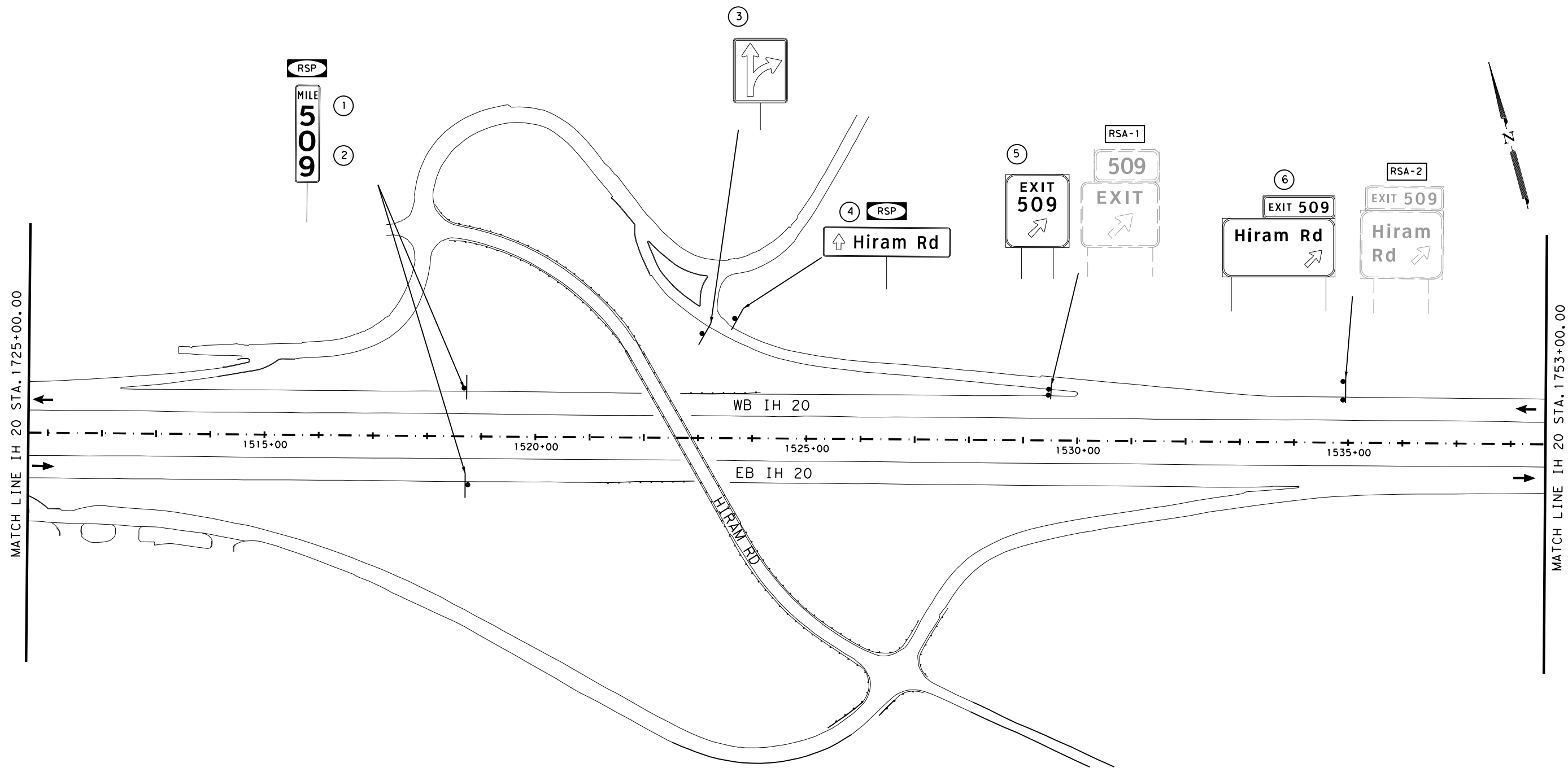

SIGNING LEGEND

- (E) EXISTING SIGN TO REMAIN
- (3) SIGN TO BE INSTALLED
- RSA REMOVE SMALL SIGN ASSEMBLY
- RLA-1 REMOVE LARGE GROUND ASSEMBLY
- RSP REPLACE SMALL SIGN PANEL
- RLP REPLACE LARGE SIGN PANEL
- ROP REPLACE OVERHEAD PANEL
- ROS-1 REMOVE OVERHEAD STRUCTURE

- * REMOVAL ITEMS THIS SHEET
- 1 (EA) SMALL SIGNS ASSEMBLY
 - 1 (EA) OVERHEAD SIGNS
 - 1 (EA) LARGE SIGNS ASSEMBLY
 - 1 (EA) WALKWAY
- * Removal Quantities are Approximate and Contractor Will be Paid For Actual Work Performed

INSTALL PROPOSED SIGNS
1 FT TO 2 FT BEHIND EXISTING
SIGN LOCATION,
UNLESS OTHERWISE NOTED.



Brenda L. Sanchez, P.E. 03/20/23
Signature of Registrar & Date

Texas Department of Transportation
© 2023

**SIGNING LAYOUT
IH 20**

SCALE: 1"=200' SHEET 103 OF 121

DESIGN/CK BLS	FED. RD. DIV. NO. 6	STATE PROJECT NO. (SEE TITLE SHEET)		HIGHWAY NO. IH 20
CHECK BLS	STATE	DISTRICT DAL	COUNTY VARIOUS	SHEET NO. 207
CHECK MA	CONTROL 0095	SECTION 14	JOB 033, ETC	
CHECK BA				

NO WORK TO BE DONE ON THIS SHEET

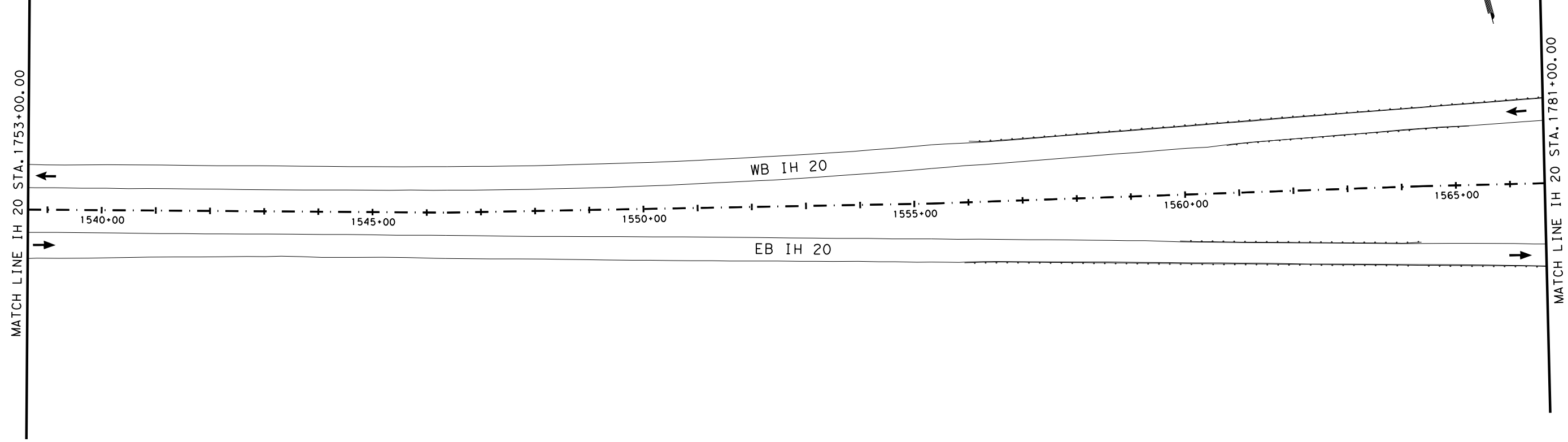

SIGNING LEGEND

- E EXISTING SIGN TO REMAIN
- 3 SIGN TO BE INSTALLED
- RSA REMOVE SMALL SIGN ASSEMBLY
- RLA-1 REMOVE LARGE GROUND ASSEMBLY
- RSP REPLACE SMALL SIGN PANEL
- RLP REPLACE LARGE SIGN PANEL
- ROP REPLACE OVERHEAD PANEL
- ROS-1 REMOVE OVERHEAD STRUCTURE

- * REMOVAL ITEMS THIS SHEET
- (EA) SMALL SIGNS ASSEMBLY
- (EA) OVERHEAD SIGNS
- (EA) LARGE SIGNS ASSEMBLY
- (EA) WALKWAY
- * Removal Quantities are Approximate and Contractor Will be Paid For Actual Work Performed

INSTALL PROPOSED SIGNS
1 FT TO 2 FT BEHIND EXISTING
SIGN LOCATION,
UNLESS OTHERWISE NOTED.

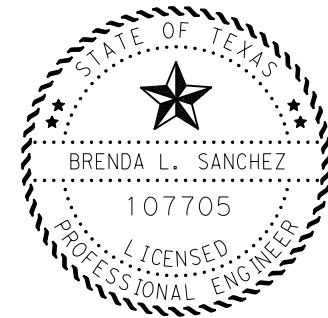

Brenda L. Sanchez, P.E. 03/20/23
Signature of Registrar & Date

©2023

SIGNING LAYOUT IH 20

SCALE: 1"=200' SHEET 104 OF 121

DESIGN/CHECK	FED. RD. DIV. NO.	STATE PROJECT NO.		HIGHWAY NO.
BLS	6	(SEE TITLE SHEET)		IH 20
CHECK	STATE	DISTRICT	COUNTY	SHEET NO.
MA	TEXAS	DAL	VARIOUS	208
CHECK	CONTROL	SECTION	JOB	
BA	0095	14	033, ETC	

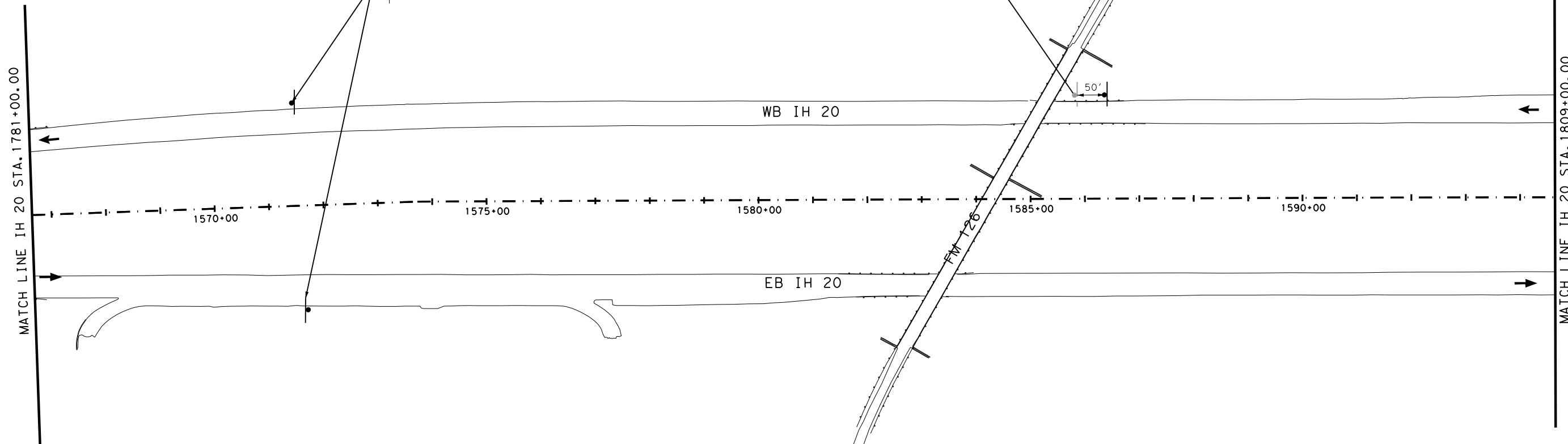

SIGNING LEGEND

- (E) EXISTING SIGN TO REMAIN
- (3) SIGN TO BE INSTALLED
- RSA REMOVE SMALL SIGN ASSEMBLY
- RLA-1 REMOVE LARGE GROUND ASSEMBLY
- RSP REPLACE SMALL SIGN PANEL
- RLP REPLACE LARGE SIGN PANEL
- ROP REPLACE OVERHEAD PANEL
- ROS-1 REMOVE OVERHEAD STRUCTURE

- * REMOVAL ITEMS THIS SHEET
- (EA) SMALL SIGNS ASSEMBLY
 - (EA) OVERHEAD SIGNS
 - 1 (EA) LARGE SIGNS ASSEMBLY
 - (EA) WALKWAY
- * Removal Quantities are Approximate and Contractor Will be Paid For Actual Work Performed

INSTALL PROPOSED SIGNS
1 FT TO 2 FT BEHIND EXISTING
SIGN LOCATION,
UNLESS OTHERWISE NOTED.

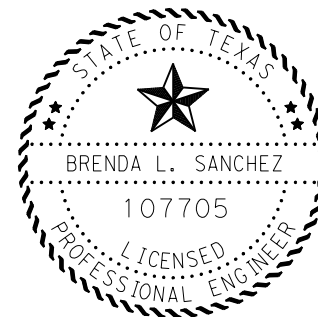

Brenda L. Sanchez, P.E. 03/20/23
Signature of Registrar & Date



**SIGNING LAYOUT
IH 20**

SCALE: 1"=200' SHEET 105 OF 121

DESIGN/CK	FED. RD. DIV. NO.	STATE PROJECT NO.		HIGHWAY NO.
BLS	6	(SEE TITLE SHEET)		IH 20
CHECK	STATE	DISTRICT	COUNTY	SHEET NO.
BLS	TEXAS	DAL	VARIOUS	209
CHECK	CONTROL	SECTION	JOB	
BA	0095	14	033, ETC	

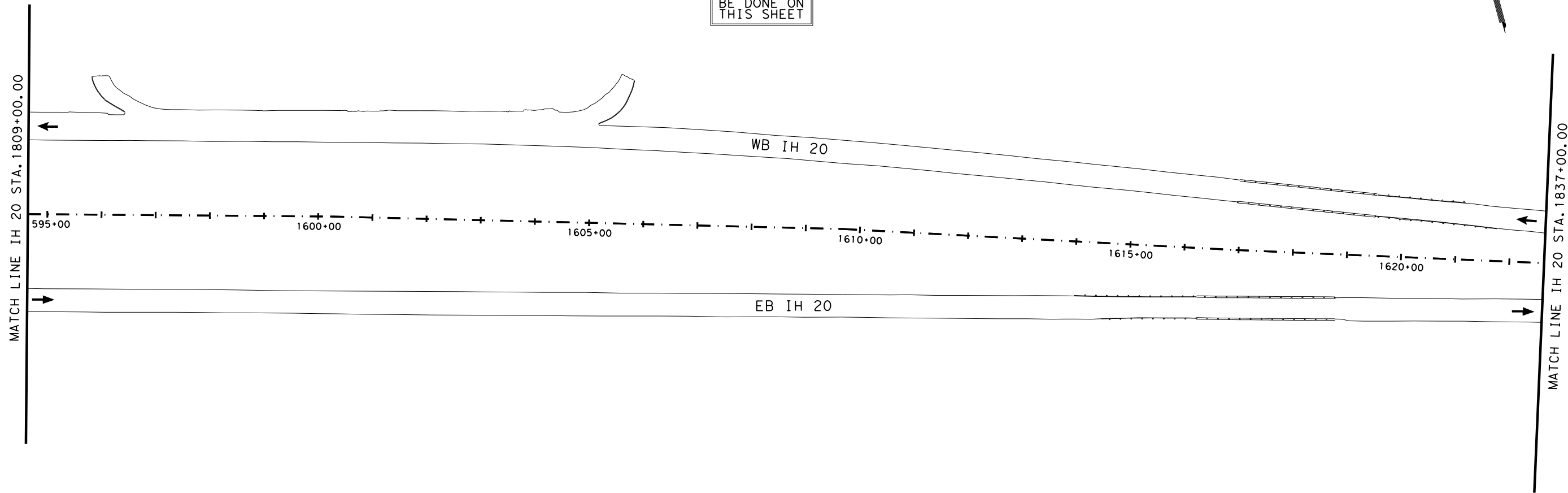

SIGNING LEGEND

- (E) EXISTING SIGN TO REMAIN
- (3) SIGN TO BE INSTALLED
- RSA REMOVE SMALL SIGN ASSEMBLY
- RLA-1 REMOVE LARGE GROUND ASSEMBLY
- RSP REPLACE SMALL SIGN PANEL
- RLP REPLACE LARGE SIGN PANEL
- ROP REPLACE OVERHEAD PANEL
- ROS-1 REMOVE OVERHEAD STRUCTURE

- * REMOVAL ITEMS THIS SHEET
- (EA) SMALL SIGNS ASSEMBLY
- (EA) OVERHEAD SIGNS
- (EA) LARGE SIGNS ASSEMBLY
- (EA) WALKWAY
- * Removal Quantities are Approximate and Contractor Will be Paid For Actual Work Performed

INSTALL PROPOSED SIGNS
1 FT TO 2 FT BEHIND EXISTING
SIGN LOCATION,
UNLESS OTHERWISE NOTED.



Brenda L. Sanchez, P.E. 03/20/23
Signature of Registrant & Date



Texas Department of Transportation
© 2023

**SIGNING LAYOUT
IH 20**

SCALE: 1"=200' SHEET 106 OF 121

DESIGN/CHECK	FED. RD. DIV. NO.	STATE PROJECT NO.		HIGHWAY NO.
BLS	6	(SEE TITLE SHEET)		IH 20
CHECK	STATE	DISTRICT	COUNTY	SHEET NO.
BLS	TEXAS	DAL	VARIOUS	210
CHECK	CONTROL	SECTION	JOB	
BA	0095	14	033, ETC	

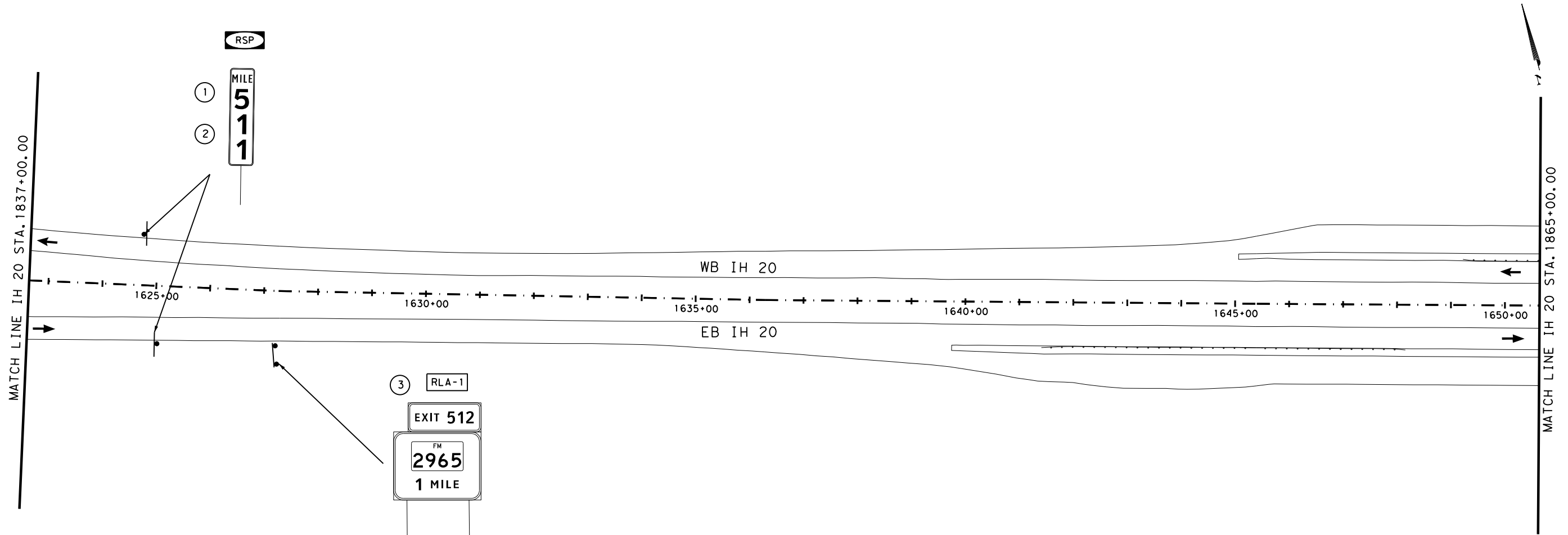

SIGNING LEGEND

- (E) EXISTING SIGN TO REMAIN
- (3) SIGN TO BE INSTALLED
- RSA REMOVE SMALL SIGN ASSEMBLY
- RLA-1 REMOVE LARGE GROUND ASSEMBLY
- RSP REPLACE SMALL SIGN PANEL
- RLP REPLACE LARGE SIGN PANEL
- ROP REPLACE OVERHEAD PANEL
- ROS-1 REMOVE OVERHEAD STRUCTURE

- * REMOVAL ITEMS THIS SHEET
- (EA) SMALL SIGNS ASSEMBLY
 - (EA) OVERHEAD SIGNS
 - 1 (EA) LARGE SIGNS ASSEMBLY
 - (EA) WALKWAY
- * Removal Quantities are Approximate and Contractor Will be Paid For Actual Work Performed

INSTALL PROPOSED SIGNS
1 FT TO 2 FT BEHIND EXISTING
SIGN LOCATION,
UNLESS OTHERWISE NOTED.

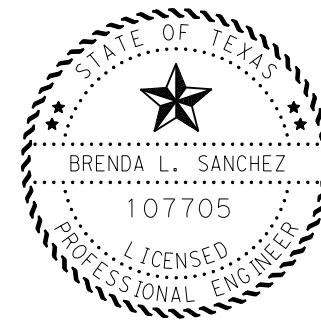

Brenda L. Sanchez, P.E. 03/20/23
Signature of Registrar & Date

Texas Department of Transportation
© 2023

**SIGNING LAYOUT
IH 20**

SCALE: 1"=200' SHEET 107 OF 121

DESIGN/CK BLS	FED. RD. DIV. NO. 6	STATE PROJECT NO. (SEE TITLE SHEET)		HIGHWAY NO. IH 20
CHECK BLS	STATE	DISTRICT DAL	COUNTY VARIOUS	SHEET NO. 211
CHECK MA	CONTROL	SECTION 14	JOB 033, ETC	
CHECK BA	0095			

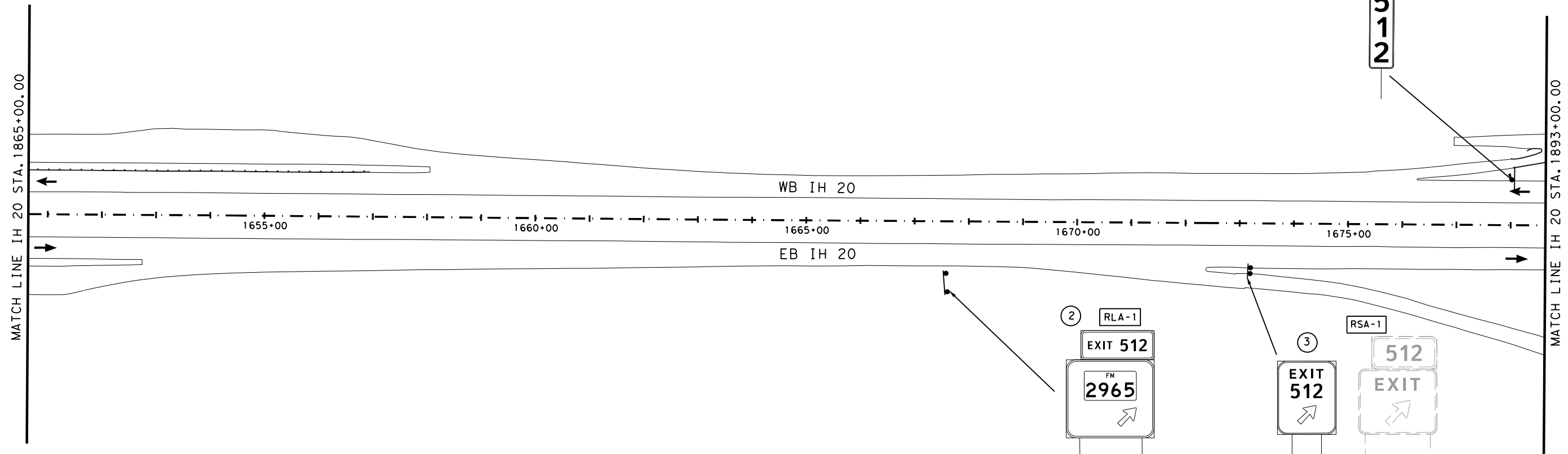

SIGNING LEGEND

- (E) EXISTING SIGN TO REMAIN
- (3) SIGN TO BE INSTALLED
- RSA REMOVE SMALL SIGN ASSEMBLY
- RLA-1 REMOVE LARGE GROUND ASSEMBLY
- RSP REPLACE SMALL SIGN PANEL
- RLP REPLACE LARGE SIGN PANEL
- ROP REPLACE OVERHEAD PANEL
- ROS-1 REMOVE OVERHEAD STRUCTURE

- * REMOVAL ITEMS THIS SHEET
- 1 (EA) SMALL SIGNS ASSEMBLY
 - 1 (EA) OVERHEAD SIGNS
 - 1 (EA) LARGE SIGNS ASSEMBLY
 - 1 (EA) WALKWAY
- * Removal Quantities are Approximate and Contractor Will be Paid For Actual Work Performed

INSTALL PROPOSED SIGNS
1 FT TO 2 FT BEHIND EXISTING
SIGN LOCATION,
UNLESS OTHERWISE NOTED.



Brenda L Sanchez, P.E. 03/20/23
Signature of Registrar & Date

Texas Department of Transportation
© 2023

**SIGNING LAYOUT
IH 20**

SCALE: 1" = 200' SHEET 108 OF 121

DESIGN/CK BLS	FED. RD. DIV. NO. 6	STATE PROJECT NO. (SEE TITLE SHEET)		HIGHWAY NO. IH 20
CHECK BLS	STATE	DISTRICT DAL	COUNTY VARIOUS	SHEET NO. 212
CHECK MA	TEXAS	SECTION 14	JOB 033, ETC	
CHECK BA	0095			

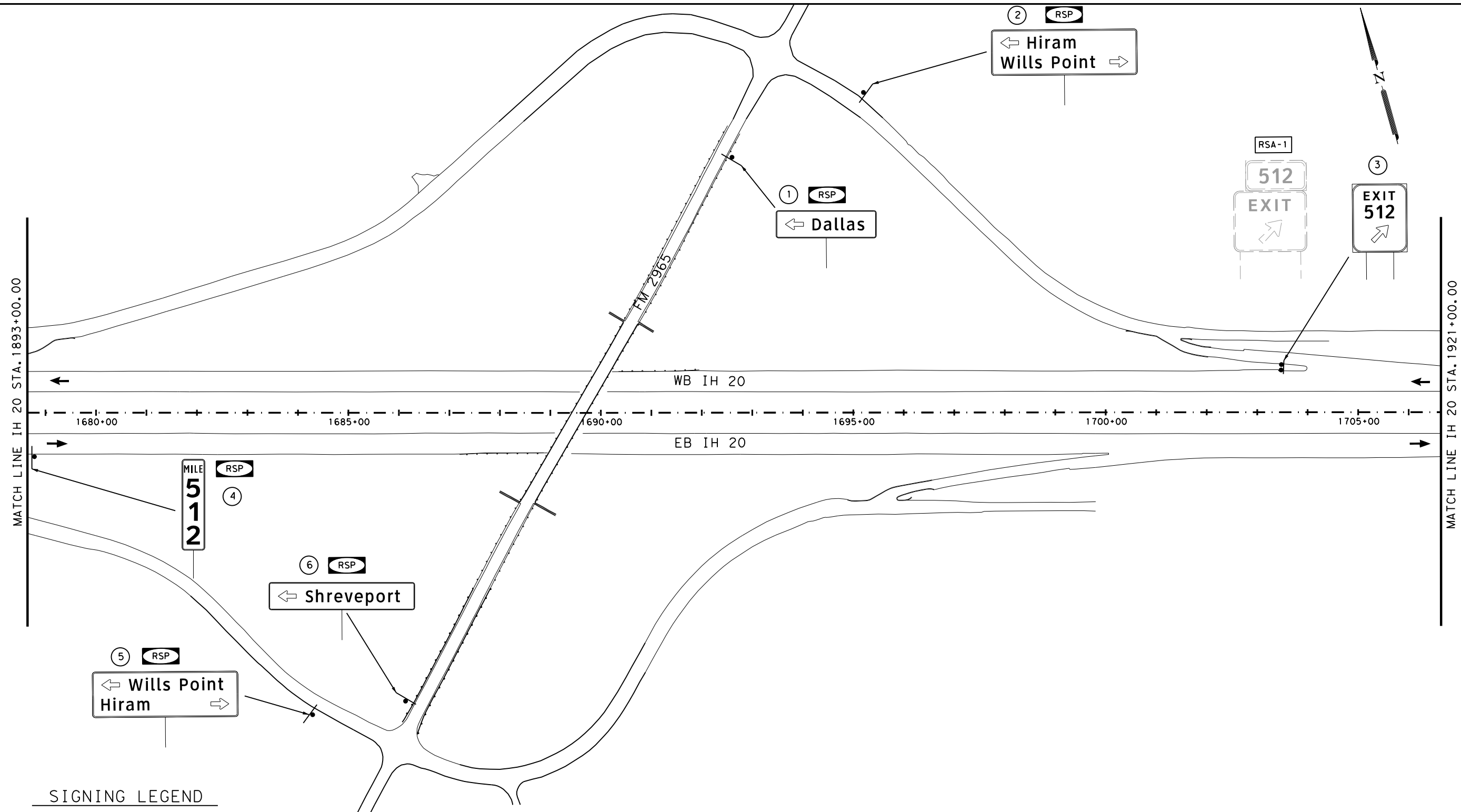

SIGNING LEGEND

- (E) EXISTING SIGN TO REMAIN
- (3) SIGN TO BE INSTALLED
- RSA REMOVE SMALL SIGN ASSEMBLY
- RLA-1 REMOVE LARGE GROUND ASSEMBLY
- RSP REPLACE SMALL SIGN PANEL
- RLP REPLACE LARGE SIGN PANEL
- ROP REPLACE OVERHEAD PANEL
- ROS-1 REMOVE OVERHEAD STRUCTURE

- * REMOVAL ITEMS THIS SHEET**
- 1 (EA) SMALL SIGNS ASSEMBLY
 - (EA) OVERHEAD SIGNS
 - (EA) LARGE SIGNS ASSEMBLY
 - (EA) WALKWAY
- * Removal Quantities are Approximate and Contractor Will be Paid For Actual Work Performed

INSTALL PROPOSED SIGNS
1 FT TO 2 FT BEHIND EXISTING
SIGN LOCATION,
UNLESS OTHERWISE NOTED.

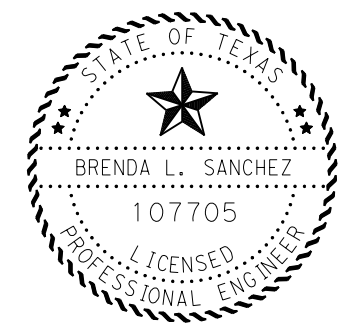

Brenda L Sanchez, P.E. 03/20/23
Signature of Registrant & Date

Texas Department of Transportation ©2023

**SIGNING LAYOUT
IH 20**

SCALE: 1"=200' SHEET 109 OF 121

DESIGN/CK BLS	FED. RD. DIV. NO. 6	STATE PROJECT NO. (SEE TITLE SHEET)		HIGHWAY NO. IH 20
CHECK BLS	STATE	DISTRICT DAL	COUNTY VARIOUS	SHEET NO. 213
CHECK MA	CONTROL	SECTION	JOB	
CHECK BA	0095	14	033, ETC	

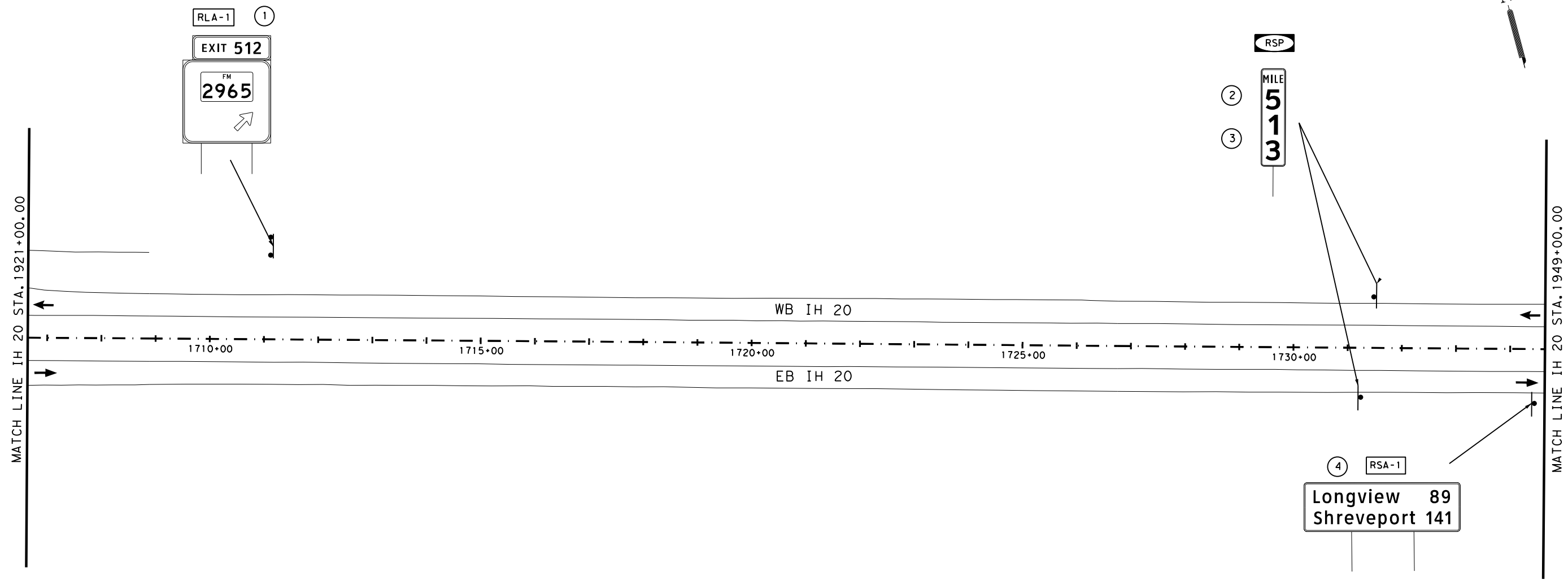

SIGNING LEGEND

- (E) EXISTING SIGN TO REMAIN
 - (3) SIGN TO BE INSTALLED
 - RSA REMOVE SMALL SIGN ASSEMBLY
 - RLA-1 REMOVE LARGE GROUND ASSEMBLY
 - RSP REPLACE SMALL SIGN PANEL
 - RLP REPLACE LARGE SIGN PANEL
 - ROP REPLACE OVERHEAD PANEL
 - ROS-1 REMOVE OVERHEAD STRUCTURE
-
- * REMOVAL ITEMS THIS SHEET
 - (EA) SMALL SIGNS ASSEMBLY
 - (EA) OVERHEAD SIGNS
 - 1 (EA) LARGE SIGNS ASSEMBLY
 - (EA) WALKWAY
-
- * Removal Quantities are Approximate and Contractor Will be Paid For Actual Work Performed

INSTALL PROPOSED SIGNS
1 FT TO 2 FT BEHIND EXISTING
SIGN LOCATION,
UNLESS OTHERWISE NOTED.



Brenda L. Sanchez, P.E. 03/20/23
Signature of Registrar & Date

Texas Department of Transportation
© 2023

**SIGNING LAYOUT
IH 20**

SCALE: 1"=200' SHEET 110 OF 121

DESIGN/CK BLS	FED. RD. DIV. NO. 6	STATE PROJECT NO. (SEE TITLE SHEET)		HIGHWAY NO. IH 20
CHECK BLS	STATE	DISTRICT DAL	COUNTY VARIOUS	SHEET NO. 214
CHECK MA	CONTROL 0095	SECTION 14	JOB 033, ETC	
CHECK BA				

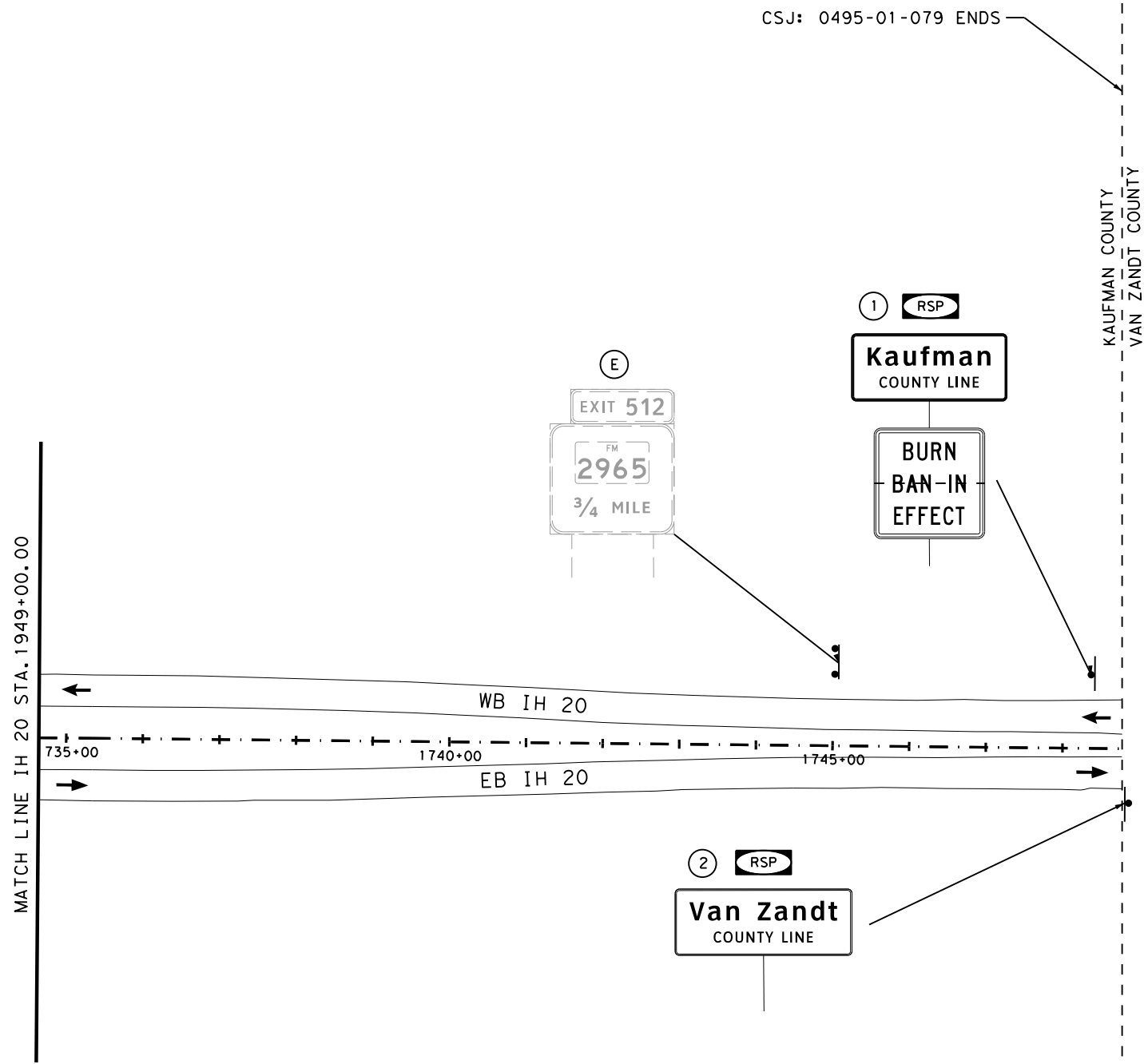

SIGNING LEGEND

- (E) EXISTING SIGN TO REMAIN
- (3) SIGN TO BE INSTALLED
- RSA REMOVE SMALL SIGN ASSEMBLY
- RLA-1 REMOVE LARGE GROUND ASSEMBLY
- RSP REPLACE SMALL SIGN PANEL
- RLP REPLACE LARGE SIGN PANEL
- ROP REPLACE OVERHEAD PANEL
- ROS-1 REMOVE OVERHEAD STRUCTURE

- * REMOVAL ITEMS THIS SHEET
- (EA) SMALL SIGNS ASSEMBLY
 - (EA) OVERHEAD SIGNS
 - (EA) LARGE SIGNS ASSEMBLY
 - (EA) WALKWAY
- * Removal Quantities are Approximate and Contractor Will be Paid For Actual Work Performed

INSTALL PROPOSED SIGNS
1 FT TO 2 FT BEHIND EXISTING
SIGN LOCATION,
UNLESS OTHERWISE NOTED.



Brenda L. Sanchez, P.E. 03/20/23
Signature of Registrar & Date



**SIGNING LAYOUT
IH 20**

SCALE: 1"=200' SHEET 111 OF 121

DESIGN/CK BLS	FED. RD. DIV. NO. 6	STATE PROJECT NO. (SEE TITLE SHEET)		HIGHWAY NO. IH 20
CHECK BLS	STATE	DISTRICT DAL	COUNTY VARIOUS	SHEET NO. 215
CHECK MA	CONTROL	SECTION	JOB	
CHECK BA	0095	14	033, ETC	

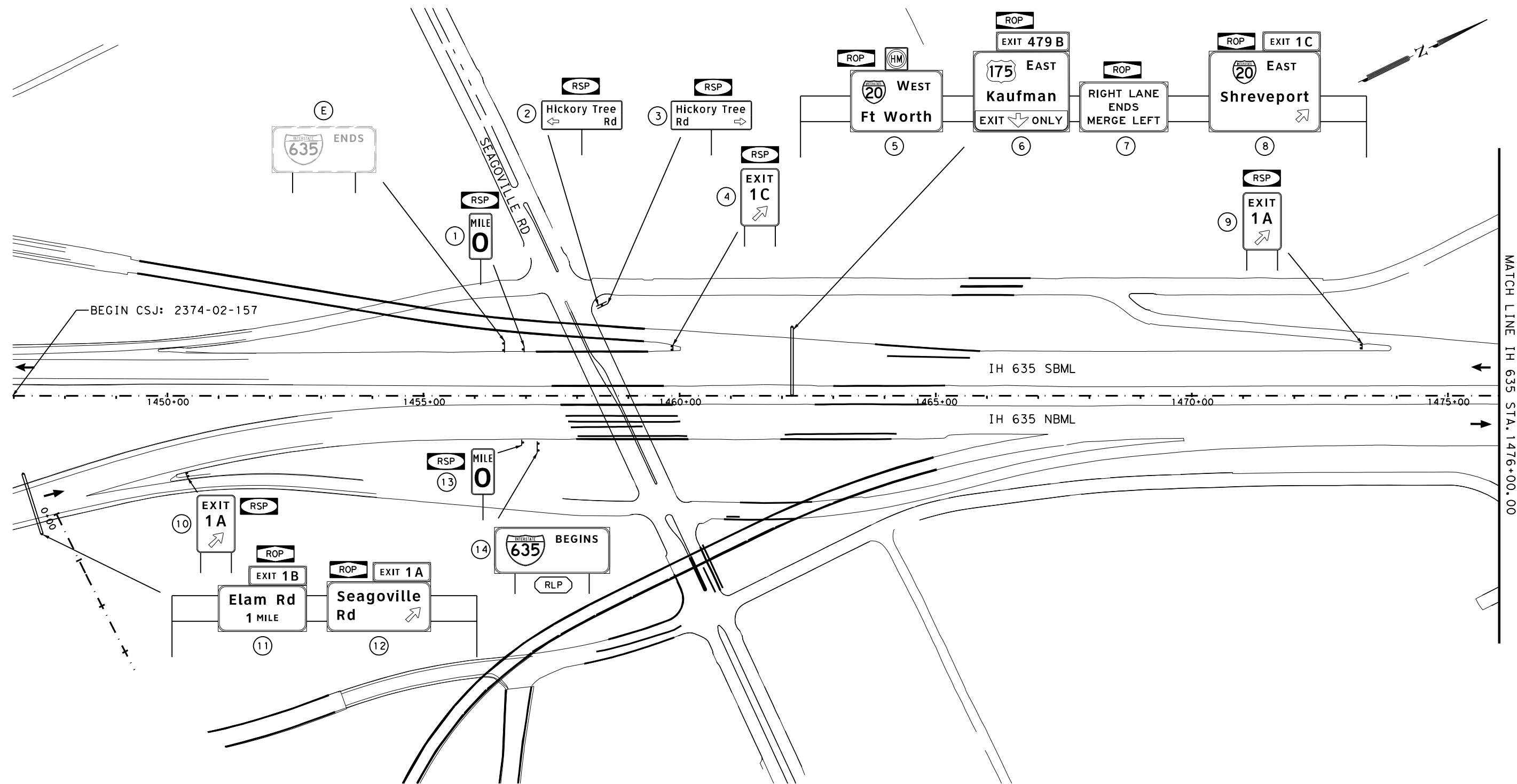

SIGNING LEGEND

- (E) EXISTING SIGN TO REMAIN
 - (3) SIGN TO BE INSTALLED
 - RSA REMOVE SMALL SIGN ASSEMBLY
 - RLA-1 REMOVE LARGE GROUND ASSEMBLY
 - RSP REPLACE SMALL SIGN PANEL
 - RLP REPLACE LARGE SIGN PANEL
 - ROP REPLACE OVERHEAD PANEL
 - ROS-1 REMOVE OVERHEAD STRUCTURE
-
- * REMOVAL ITEMS THIS SHEET
 - (EA) SMALL SIGNS ASSEMBLY
 - (EA) OVERHEAD SIGNS
 - (EA) LARGE SIGNS ASSEMBLY
 - (EA) WALKWAY
 - * Removal Quantities are Approximate and Contractor Will be Paid For Actual Work Performed

INSTALL PROPOSED SIGNS
1 FT TO 2 FT BEHIND EXISTING
SIGN LOCATION,
UNLESS OTHERWISE NOTED.

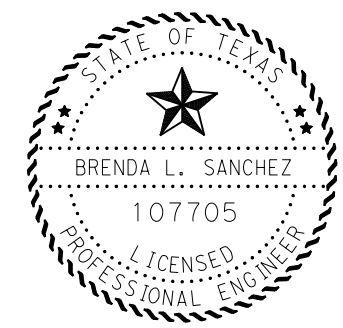

Brenda L. Sanchez, P.E. 03/20/23
Signature of Registrar & Date

Texas Department of Transportation
© 2023

SIGNING LAYOUT
IH 635

SCALE: 1"=200' SHEET 112 OF 121

DESIGN/CK	FED. RD. DIV. NO.	STATE PROJECT NO.		HIGHWAY NO.
BLS	6	(SEE TITLE SHEET)		IH 20
CHECK	STATE	DISTRICT	COUNTY	SHEET NO.
BLS	TEXAS	DAL	VARIOUS	216
CHECK	CONTROL	SECTION	JOB	
MA	0095	14	033, ETC	

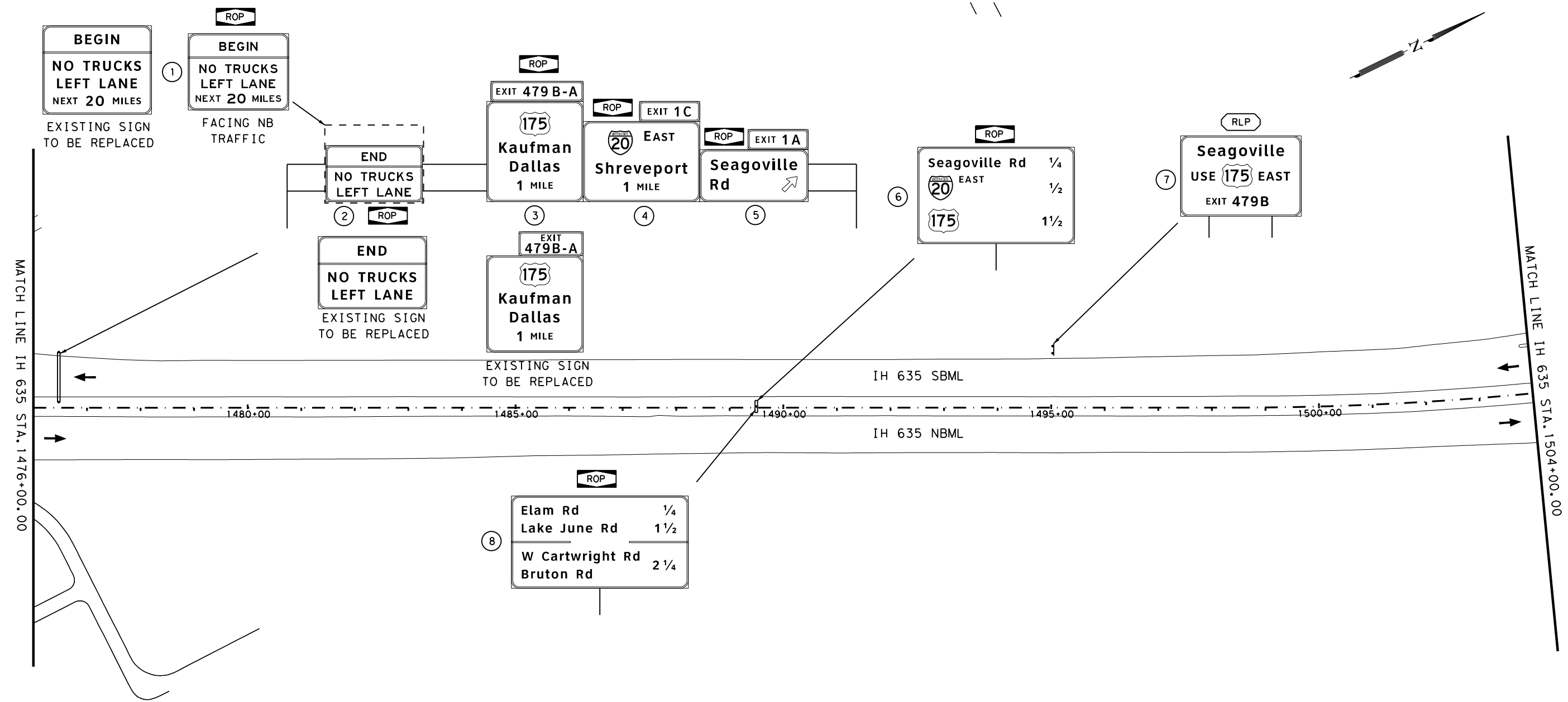

SIGNING LEGEND

- (E) EXISTING SIGN TO REMAIN
- (3) SIGN TO BE INSTALLED
- RSA REMOVE SMALL SIGN ASSEMBLY
- RLA-1 REMOVE LARGE GROUND ASSEMBLY
- RSP REPLACE SMALL SIGN PANEL
- RLP REPLACE LARGE SIGN PANEL
- ROP REPLACE OVERHEAD PANEL
- ROS-1 REMOVE OVERHEAD STRUCTURE

- * REMOVAL ITEMS THIS SHEET
- (EA) SMALL SIGNS ASSEMBLY
 - (EA) OVERHEAD SIGNS
 - (EA) LARGE SIGNS ASSEMBLY
 - (EA) WALKWAY
- * Removal Quantities are Approximate and Contractor Will be Paid For Actual Work Performed

INSTALL PROPOSED SIGNS
1 FT TO 2 FT BEHIND EXISTING
SIGN LOCATION,
UNLESS OTHERWISE NOTED.

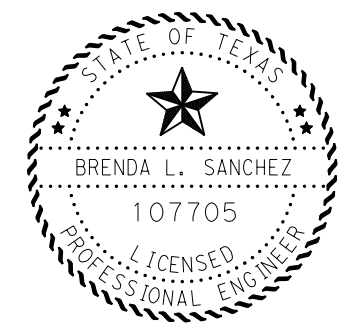

Brenda L Sanchez, P.E. 03/20/23
Signature of Registrar & Date

Texas Department of Transportation
© 2023

**SIGNING LAYOUT
IH 635**

SCALE: 1"=200' SHEET 113 OF 121

DESIGN/CK BLS	FED. RD. DIV. NO. 6	STATE PROJECT NO. (SEE TITLE SHEET)		HIGHWAY NO. IH 20
CHECK BLS	STATE	DISTRICT	COUNTY	SHEET NO.
CHECK MA	TEXAS	DAL	VARIOUS	217
CHECK BA	CONTROL	SECTION	JOB	
	0095	14	033, ETC	

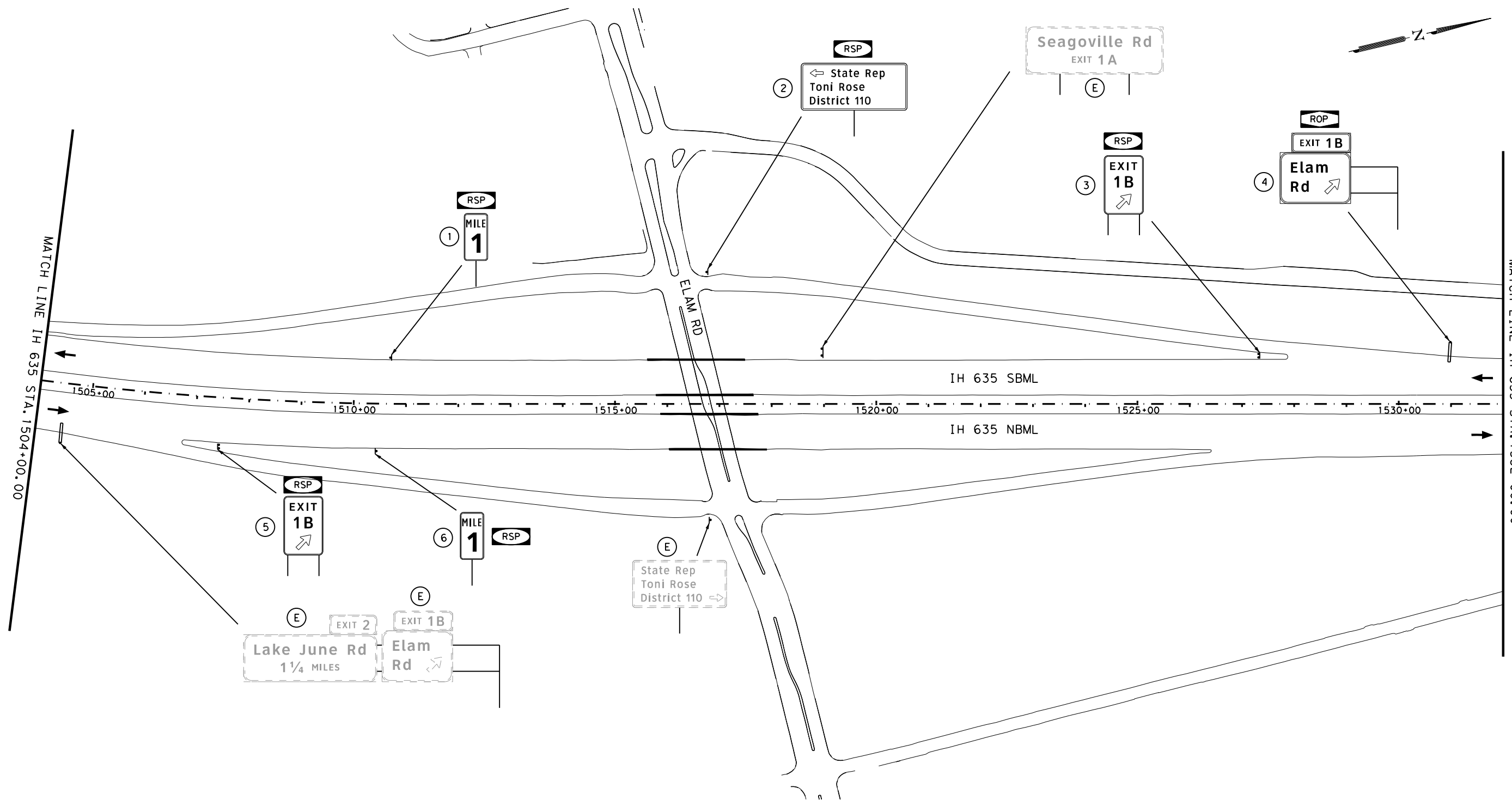

SIGNING LEGEND

- (E) EXISTING SIGN TO REMAIN
 - (3) SIGN TO BE INSTALLED
 - RSA REMOVE SMALL SIGN ASSEMBLY
 - RLA-1 REMOVE LARGE GROUND ASSEMBLY
 - RSP REPLACE SMALL SIGN PANEL
 - RLP REPLACE LARGE SIGN PANEL
 - ROP REPLACE OVERHEAD PANEL
 - ROS-1 REMOVE OVERHEAD STRUCTURE
-
- * REMOVAL ITEMS THIS SHEET
 - (EA) SMALL SIGNS ASSEMBLY
 - (EA) OVERHEAD SIGNS
 - (EA) LARGE SIGNS ASSEMBLY
 - (EA) WALKWAY
-
- * Removal Quantities are Approximate and Contractor Will be Paid For Actual Work Performed

INSTALL PROPOSED SIGNS
1 FT TO 2 FT BEHIND EXISTING
SIGN LOCATION,
UNLESS OTHERWISE NOTED.

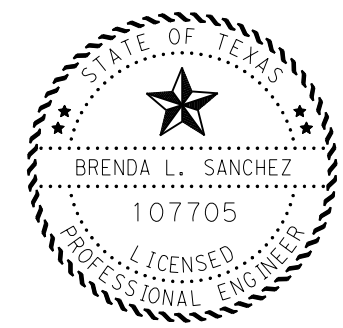

Brenda L Sanchez, P.E. 03/20/23
Signature of Registrar & Date

 Texas Department of Transportation © 2023				
SIGNING LAYOUT IH 635				
SCALE: 1"=200'			SHEET 1140F 121	
DESIGN/CK	FED. RD. DIV. NO.	STATE PROJECT NO.		HIGHWAY NO.
BLS	6	(SEE TITLE SHEET)		IH 20
CHECK	STATE	DISTRICT	COUNTY	SHEET NO.
BLS	TEXAS	DAL	VARIOUS	218
CHECK	CONTROL	SECTION	JOB	
BA	0095	14	033, ETC	

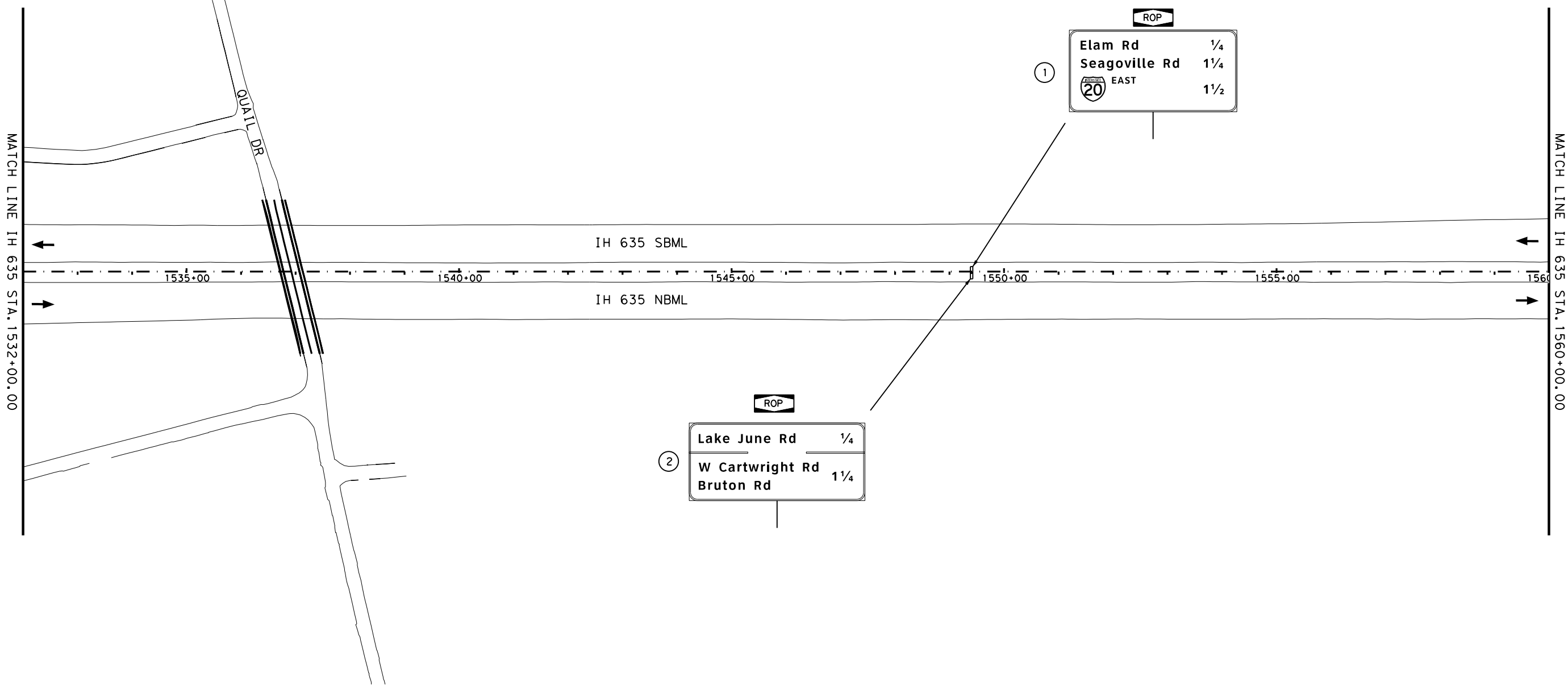
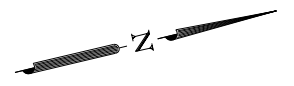

SIGNING LEGEND

- (E) EXISTING SIGN TO REMAIN
 - (3) SIGN TO BE INSTALLED
 - RSA REMOVE SMALL SIGN ASSEMBLY
 - RLA-1 REMOVE LARGE GROUND ASSEMBLY
 - RSP REPLACE SMALL SIGN PANEL
 - RLP REPLACE LARGE SIGN PANEL
 - ROP REPLACE OVERHEAD PANEL
 - ROS-1 REMOVE OVERHEAD STRUCTURE
-
- * REMOVAL ITEMS THIS SHEET
 - (EA) SMALL SIGNS ASSEMBLY
 - (EA) OVERHEAD SIGNS
 - (EA) LARGE SIGNS ASSEMBLY
 - (EA) WALKWAY
-
- * Removal Quantities are Approximate and Contractor Will be Paid For Actual Work Performed

INSTALL PROPOSED SIGNS
1 FT TO 2 FT BEHIND EXISTING
SIGN LOCATION,
UNLESS OTHERWISE NOTED.

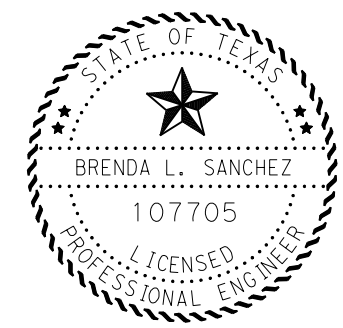

Brenda L. Sanchez, P.E. 03/20/23
Signature of Registrant & Date

Texas Department of Transportation
© 2023

**SIGNING LAYOUT
IH 635**

SCALE: 1"=200' SHEET 1150F 121

DESIGN/CK BLS	FED. RD. DIV. NO. 6	STATE PROJECT NO. (SEE TITLE SHEET)		HIGHWAY NO. IH 20
CHECK BLS	STATE	DISTRICT	COUNTY	SHEET NO.
CHECK MA	TEXAS	DAL	VARIOUS	219
CHECK BA	CONTROL	SECTION	JOB	
	0095	14	033, ETC	

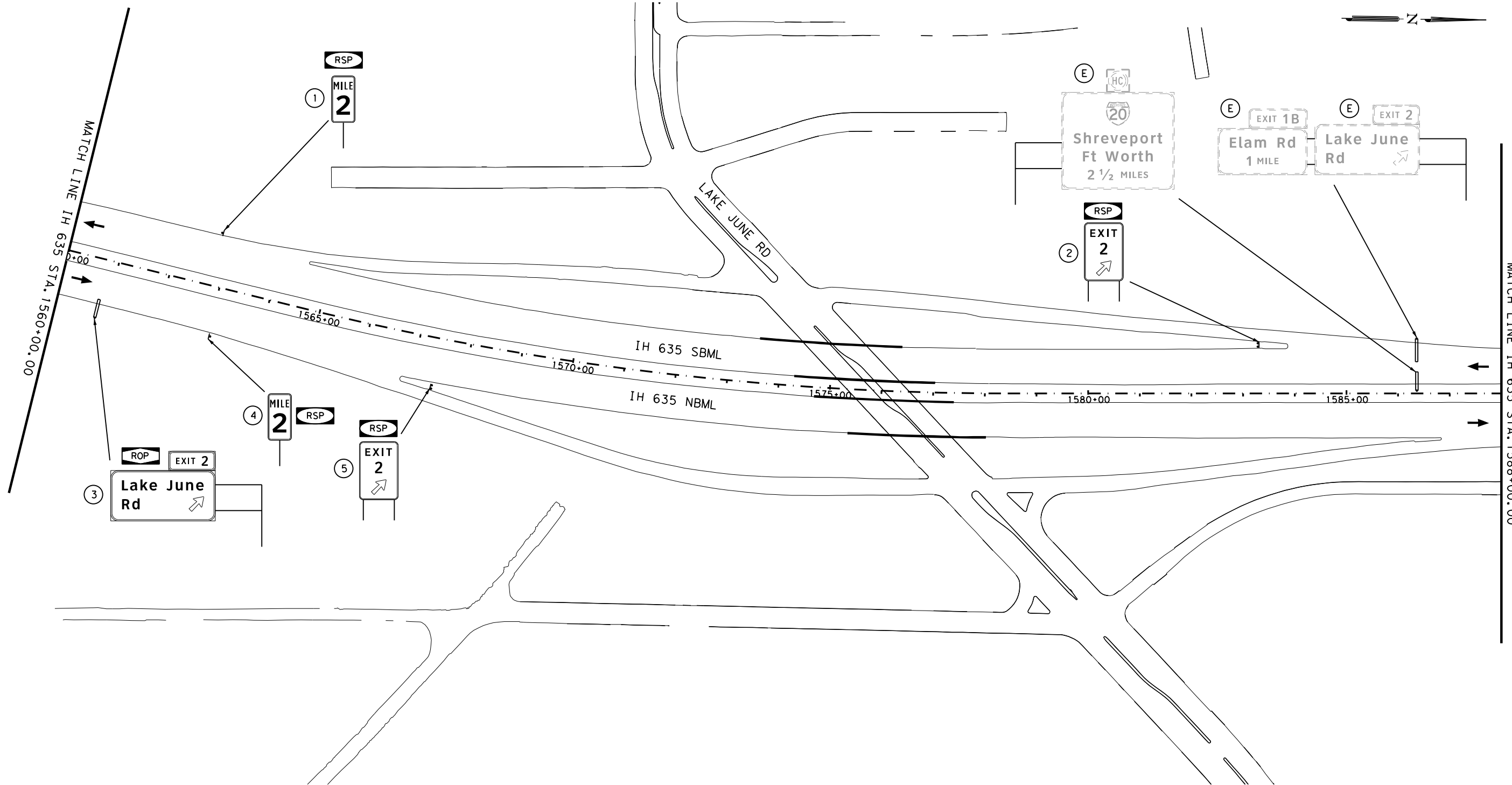

SIGNING LEGEND

- (E) EXISTING SIGN TO REMAIN
 - (3) SIGN TO BE INSTALLED
 - RSA REMOVE SMALL SIGN ASSEMBLY
 - RLA-1 REMOVE LARGE GROUND ASSEMBLY
 - RSP REPLACE SMALL SIGN PANEL
 - RLP REPLACE LARGE SIGN PANEL
 - ROP REPLACE OVERHEAD PANEL
 - ROS-1 REMOVE OVERHEAD STRUCTURE
-
- * REMOVAL ITEMS THIS SHEET
 - (EA) SMALL SIGNS ASSEMBLY
 - (EA) OVERHEAD SIGNS
 - (EA) LARGE SIGNS ASSEMBLY
 - (EA) WALKWAY
-
- * Removal Quantities are Approximate and Contractor Will be Paid For Actual Work Performed

INSTALL PROPOSED SIGNS
1 FT TO 2 FT BEHIND EXISTING
SIGN LOCATION,
UNLESS OTHERWISE NOTED.



Brenda L Sanchez, P.E. 03/20/23
Signature of Registrar & Date



**SIGNING LAYOUT
IH 635**

SCALE: 1"=200' SHEET 1160F 121

DESIGN/CK	FED. RD. DIV. NO.	STATE PROJECT NO.		HIGHWAY NO.
BLS	6	(SEE TITLE SHEET)		IH 20
CHECK	STATE	DISTRICT	COUNTY	SHEET NO.
BLS	TEXAS	DAL	VARIOUS	220
CHECK	CONTROL	SECTION	JOB	
MA	0095	14	033, ETC	

3/17/2023 3:47:26 PM T:\DAL\TRAFM\FY_2023_PS&E\IH_20\Pion_Set\IH_635_Signing\IH_635_Signing Layouts.dgn

MATCH LINE IH 635 STA. 1588+00.00

MATCH LINE IH 635 STA. 1616+00.00

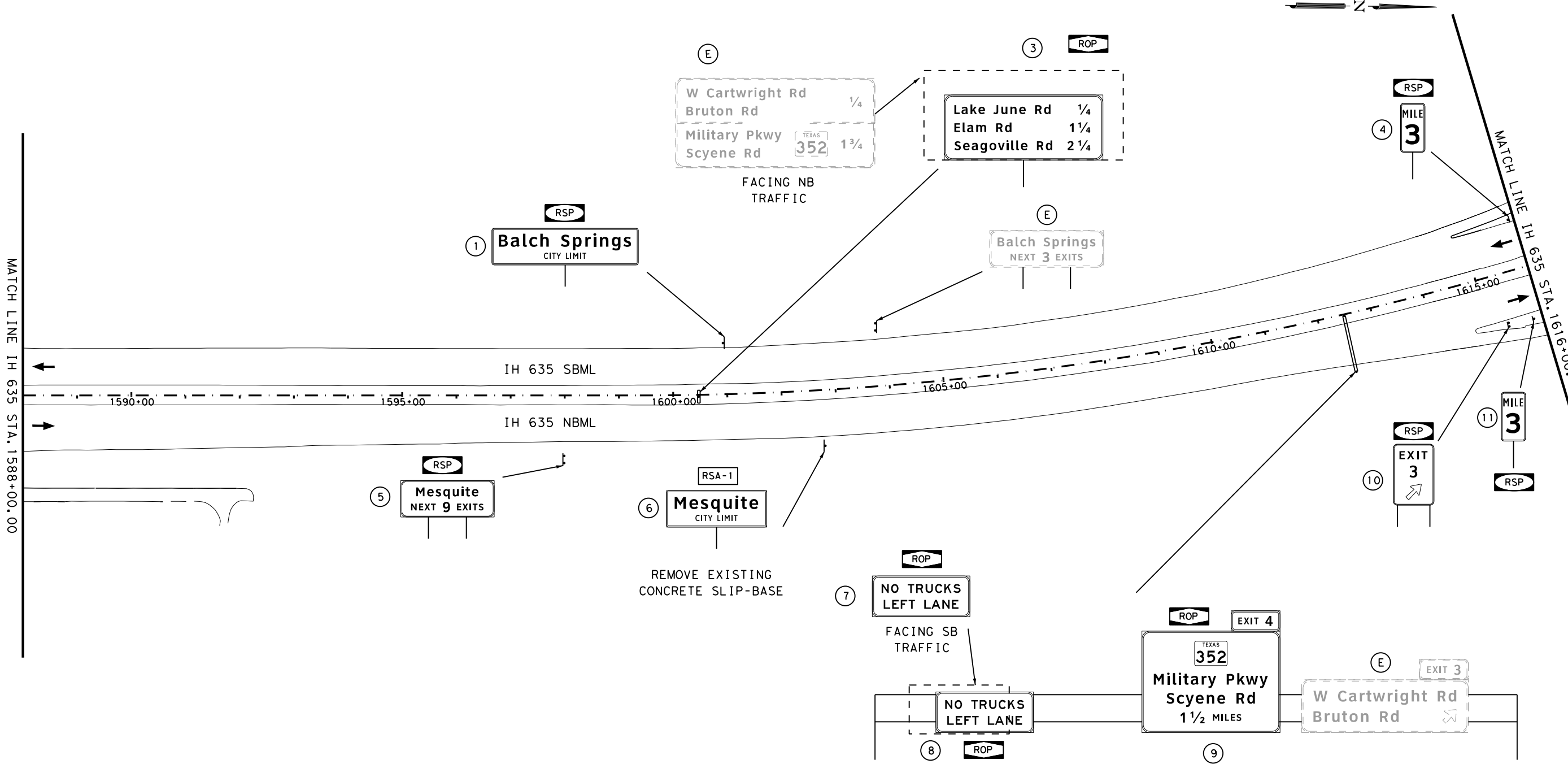

SIGNING LEGEND

- (E) EXISTING SIGN TO REMAIN
- (3) SIGN TO BE INSTALLED
- RSA REMOVE SMALL SIGN ASSEMBLY
- RLA-1 REMOVE LARGE GROUND ASSEMBLY
- RSP REPLACE SMALL SIGN PANEL
- RLP REPLACE LARGE SIGN PANEL
- ROP REPLACE OVERHEAD PANEL
- ROS-1 REMOVE OVERHEAD STRUCTURE

- * REMOVAL ITEMS THIS SHEET**
- 1 (EA) SMALL SIGNS ASSEMBLY
 - (EA) OVERHEAD SIGNS
 - (EA) LARGE SIGNS ASSEMBLY
 - (EA) WALKWAY
- * Removal Quantities are Approximate and Contractor Will be Paid For Actual Work Performed**

INSTALL PROPOSED SIGNS
1 FT TO 2 FT BEHIND EXISTING
SIGN LOCATION,
UNLESS OTHERWISE NOTED.

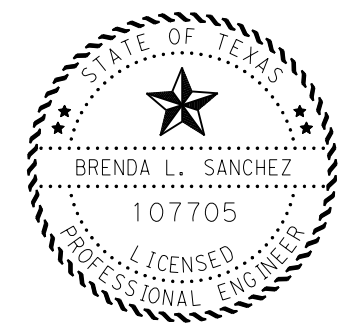

Brenda L Sanchez, P.E. 03/20/23
Signature of Registrar & Date

Texas Department of Transportation
© 2023

**SIGNING LAYOUT
IH 635**

SCALE: 1"=200' SHEET 117 OF 121

DESIGN/CK BLS	FED. RD. DIV. NO. 6	STATE PROJECT NO. (SEE TITLE SHEET)		HIGHWAY NO. IH 20
CHECK BLS	STATE	DISTRICT DAL	COUNTY VARIOUS	SHEET NO. 221
CHECK MA	TEXAS	SECTION 0095	JOB 14	221
CHECK BA	CONTROL	033, ETC		

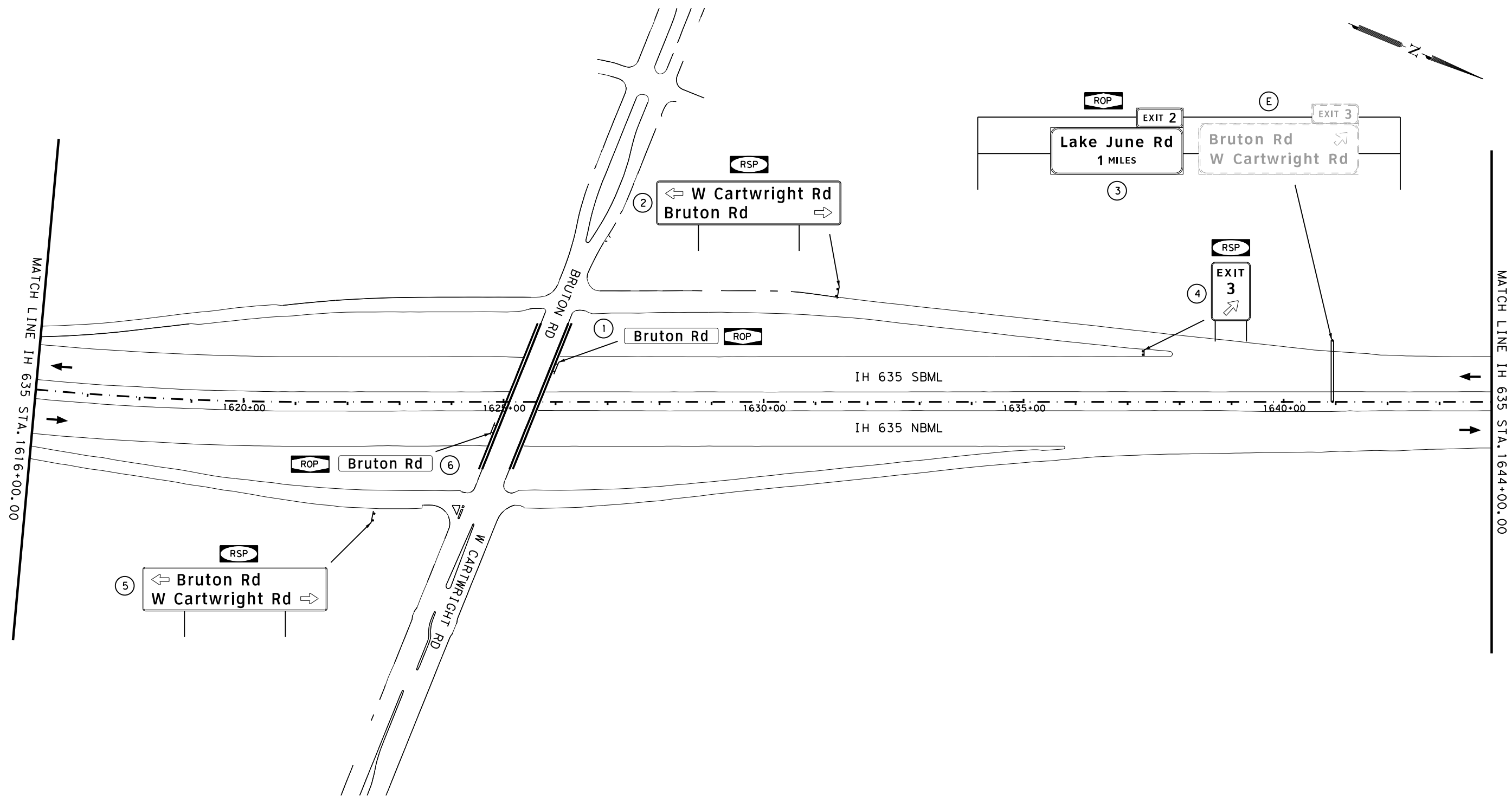

SIGNING LEGEND

- (E) EXISTING SIGN TO REMAIN
 - (3) SIGN TO BE INSTALLED
 - RSA REMOVE SMALL SIGN ASSEMBLY
 - RLA-1 REMOVE LARGE GROUND ASSEMBLY
 - RSP REPLACE SMALL SIGN PANEL
 - RLP REPLACE LARGE SIGN PANEL
 - ROP REPLACE OVERHEAD PANEL
 - ROS-1 REMOVE OVERHEAD STRUCTURE
-
- * REMOVAL ITEMS THIS SHEET
 - (EA) SMALL SIGNS ASSEMBLY
 - (EA) OVERHEAD SIGNS
 - (EA) LARGE SIGNS ASSEMBLY
 - (EA) WALKWAY
-
- * Removal Quantities are Approximate and Contractor Will be Paid For Actual Work Performed

INSTALL PROPOSED SIGNS
1 FT TO 2 FT BEHIND EXISTING
SIGN LOCATION,
UNLESS OTHERWISE NOTED.



Brenda L Sanchez, P.E. 03/20/23
Signature of Registrant & Date

Texas Department of Transportation
© 2023

**SIGNING LAYOUT
IH 635**

SCALE: 1"=200' SHEET 1180F 121

DESIGN/CK BLS	FED. RD. DIV. NO. 6	STATE PROJECT NO. (SEE TITLE SHEET)		HIGHWAY NO. IH 20
CHECK BLS	STATE	DISTRICT	COUNTY	SHEET NO.
CHECK MA	TEXAS	DAL	VARIOUS	222
CHECK BA	CONTROL	SECTION	JOB	
	0095	14	033, ETC	

MATCH LINE IH 635 STA. 1644+00.00

MATCH LINE IH 635 STA. 1672+00.00

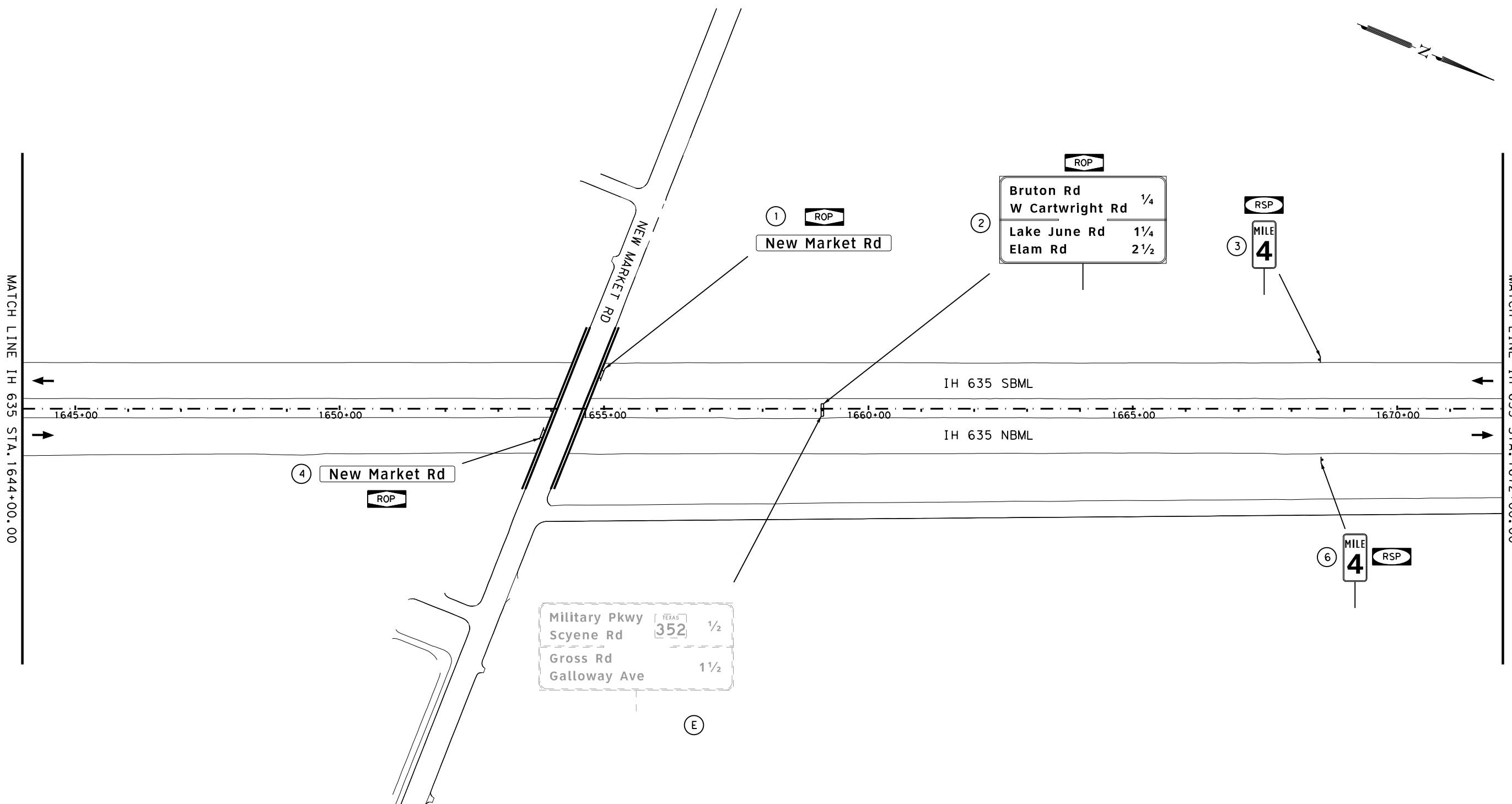

SIGNING LEGEND

- (E) EXISTING SIGN TO REMAIN
 - (3) SIGN TO BE INSTALLED
 - RSA REMOVE SMALL SIGN ASSEMBLY
 - RLA-1 REMOVE LARGE GROUND ASSEMBLY
 - RSP REPLACE SMALL SIGN PANEL
 - RLP REPLACE LARGE SIGN PANEL
 - ROP REPLACE OVERHEAD PANEL
 - ROS-1 REMOVE OVERHEAD STRUCTURE
-
- * REMOVAL ITEMS THIS SHEET
 - (EA) SMALL SIGNS ASSEMBLY
 - (EA) OVERHEAD SIGNS
 - (EA) LARGE SIGNS ASSEMBLY
 - (EA) WALKWAY
-
- * Removal Quantities are Approximate and Contractor Will be Paid For Actual Work Performed

INSTALL PROPOSED SIGNS
1 FT TO 2 FT BEHIND EXISTING
SIGN LOCATION,
UNLESS OTHERWISE NOTED.

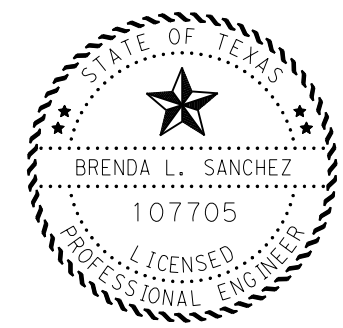

Brenda L. Sanchez, P.E. 03/20/23
Signature of Registrar & Date



**SIGNING LAYOUT
IH 635**

SCALE: 1"=200' SHEET 1190F 121

DESIGN/CK BLS	FED. RD. DIV. NO. 6	STATE PROJECT NO. (SEE TITLE SHEET)		HIGHWAY NO. IH 20
CHECK BLS	STATE	DISTRICT	COUNTY	SHEET NO.
CHECK MA	TEXAS	DAL	VARIOUS	223
CHECK BA	CONTROL	SECTION	JOB	
	0095	14	033, ETC	

MATCH LINE IH 635 STA. 1672+00.00

MATCH LINE IH 635 STA. 1700+00.00

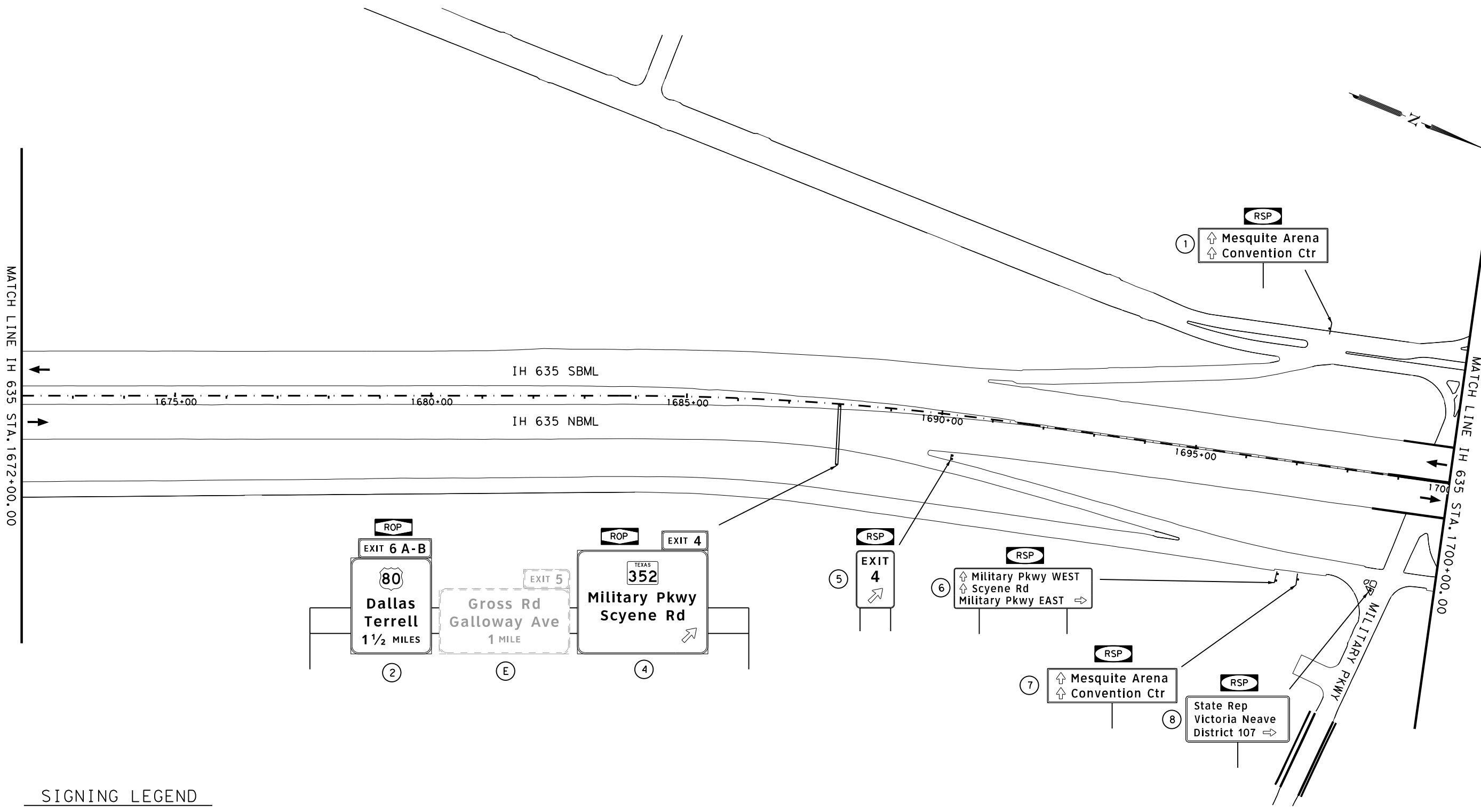

SIGNING LEGEND

- (E) EXISTING SIGN TO REMAIN
- (3) SIGN TO BE INSTALLED
- RSA REMOVE SMALL SIGN ASSEMBLY
- RLA-1 REMOVE LARGE GROUND ASSEMBLY
- RSP REPLACE SMALL SIGN PANEL
- RLP REPLACE LARGE SIGN PANEL
- ROP REPLACE OVERHEAD PANEL
- ROS-1 REMOVE OVERHEAD STRUCTURE

- * REMOVAL ITEMS THIS SHEET
- (EA) SMALL SIGNS ASSEMBLY
 - (EA) OVERHEAD SIGNS
 - (EA) LARGE SIGNS ASSEMBLY
 - (EA) WALKWAY
- * Removal Quantities are Approximate and Contractor Will be Paid For Actual Work Performed

INSTALL PROPOSED SIGNS
1 FT TO 2 FT BEHIND EXISTING
SIGN LOCATION,
UNLESS OTHERWISE NOTED.

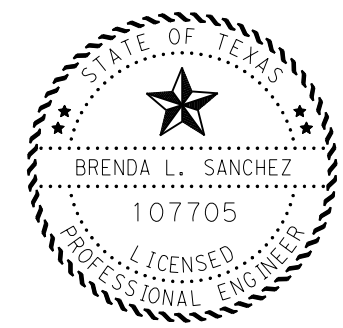

Brenda L Sanchez, P.E. 03/20/23
Signature of Registrar & Date



**SIGNING LAYOUT
IH 635**

SCALE: 1"=200' SHEET 1200F 121

DESIGN/CK BLS	FED. RD. DIV. NO. 6	STATE PROJECT NO. (SEE TITLE SHEET)		HIGHWAY NO. IH 20
CHECK BLS	STATE	DISTRICT	COUNTY	SHEET NO.
CHECK MA	TEXAS	DAL	VARIOUS	224
CHECK BA	CONTROL	SECTION	JOB	
	0095	14	033, ETC	

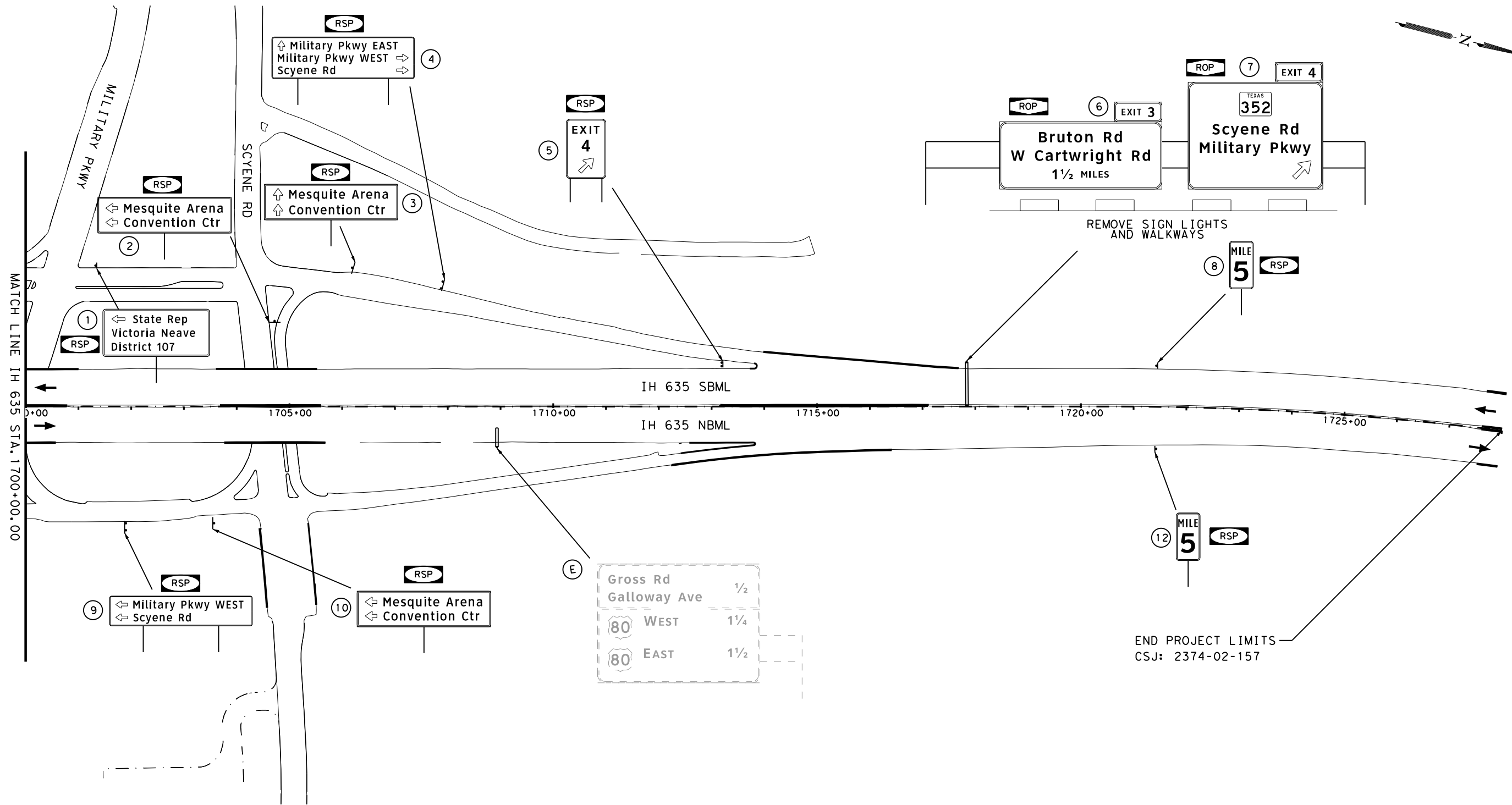

REMOVE SIGN LIGHTS AND WALKWAYS

END PROJECT LIMITS
CSJ: 2374-02-157

SIGNING LEGEND

- (E) EXISTING SIGN TO REMAIN
 - (3) SIGN TO BE INSTALLED
 - RSA REMOVE SMALL SIGN ASSEMBLY
 - RLA-1 REMOVE LARGE GROUND ASSEMBLY
 - RSP REPLACE SMALL SIGN PANEL
 - RLP REPLACE LARGE SIGN PANEL
 - ROP REPLACE OVERHEAD PANEL
 - ROS-1 REMOVE OVERHEAD STRUCTURE
-
- * REMOVAL ITEMS THIS SHEET
 - (EA) SMALL SIGNS ASSEMBLY
 - (EA) OVERHEAD SIGNS
 - (EA) LARGE SIGNS ASSEMBLY
 - 1 (EA) WALKWAY
-
- * Removal Quantities are Approximate and Contractor Will be Paid For Actual Work Performed

INSTALL PROPOSED SIGNS
1 FT TO 2 FT BEHIND EXISTING
SIGN LOCATION,
UNLESS OTHERWISE NOTED.

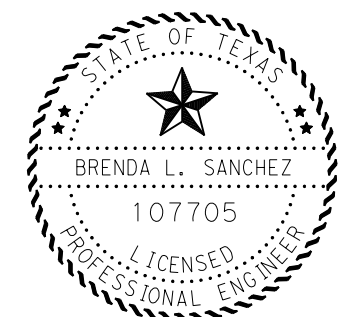

Brenda L Sanchez, P.E. 03/20/23
Signature of Registrar & Date

Texas Department of Transportation
© 2023

SIGNING LAYOUT IH 635

SCALE: 1" = 200' SHEET 121 OF 121

DESIGN/CK BLS	FED. RD. DIV. NO. 6	STATE PROJECT NO. (SEE TITLE SHEET)		HIGHWAY NO. IH 20
CHECK BLS	STATE	DISTRICT DAL	COUNTY VARIOUS	SHEET NO. 225
CHECK MA	CONTROL	SECTION 14	JOB 033, ETC	
CHECK BA	0095			

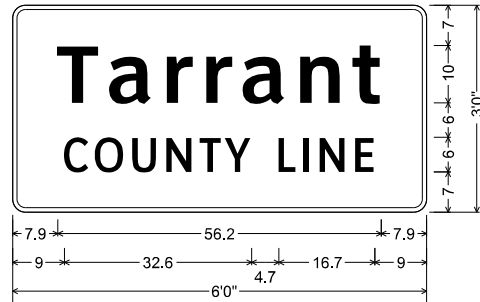

I-2dT 10in;
 2.3" Radius, 0.8" Border, White on Green;
 "Tarrant", ClearviewHwy-5-W-R;
 "COUNTY LINE", ClearviewHwy-3-W;

SHEET 1 SIGN 1

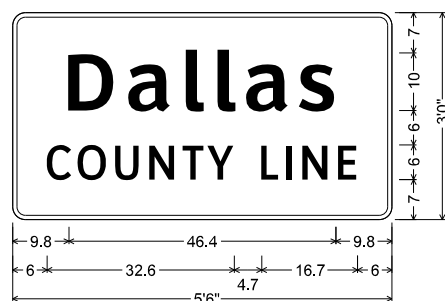

I-2dT 10in;
 2.3" Radius, 0.8" Border, White on Green;
 "Dallas", ClearviewHwy-5-W-R;
 "COUNTY LINE", ClearviewHwy-3-W;

SHEET 1 SIGN 5
SHEET 60 SIGN 3

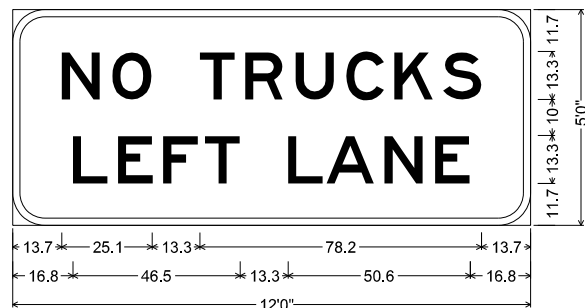

9.0" Radius, 2.0" Border, Black on White;
 "NO TRUCKS", E; "LEFT LANE", E;

SHEET 1 SIGN 6	SHEET 54 SIGN 5
SHEET 2 SIGN 1	SHEET 55 SIGN 3
SHEET 6 SIGN 2	SHEET 58 SIGN 2
SHEET 7 SIGN 5	SHEET 117 SIGN 7
SHEET 13 SIGN 1	SHEET 117 SIGN 8
SHEET 13 SIGN 10	
SHEET 25 SIGN 4	
SHEET 31 SIGN 3	
SHEET 36 SIGN 5	
SHEET 42 SIGN 2	

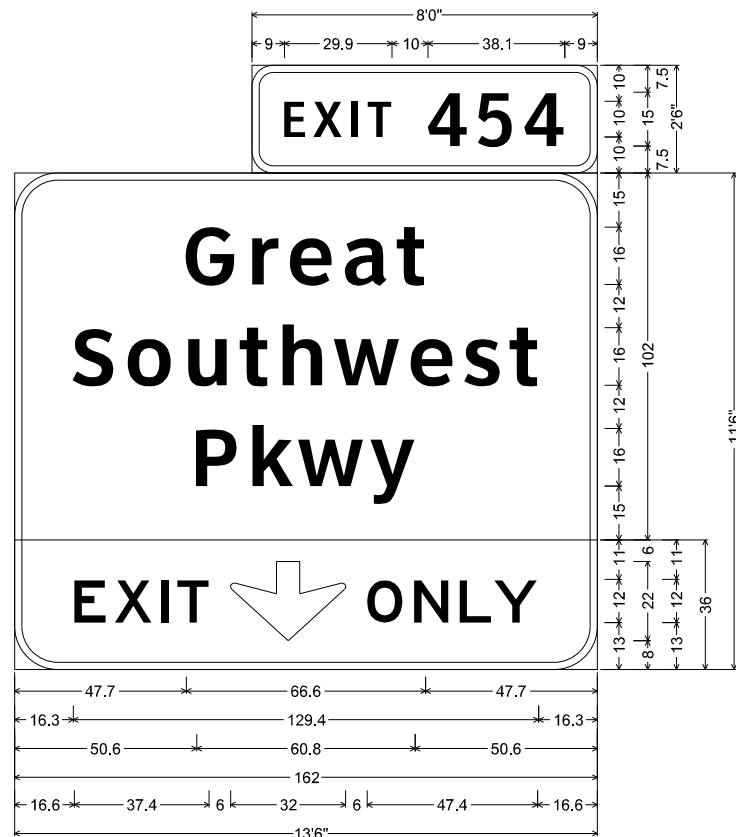

6.0" Radius, 2.0" Border, White on Green;
 "EXIT 454", ClearviewHwy-4-W;
 12.0" Radius, 2.0" Border, White on Green;
 "Great", ClearviewHwy-5-W-R; "Southwest", ClearviewHwy-5-W-R;
 "Pkwy", ClearviewHwy-5-W-R;

12.0" Radius, 2.0" Border, Black on Yellow;
 "EXIT", E; "ONLY", E;

SHEET 1 SIGN 2

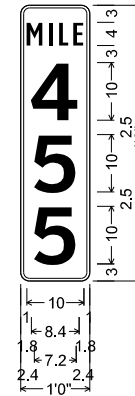

D10-3 10in;
 1.5" Radius, 0.5" Border, White on Green;
 "MILE", ClearviewHwy-2-W;
 "4", ClearviewHwy-6-W;
 "5", ClearviewHwy-6-W;
 "5", ClearviewHwy-6-W;

SHEET 1 SIGN 3
SHEET 1 SIGN 4



6.0" Radius, 2.0" Border, White on Green;
 "EXIT 455 B", ClearviewHwy-4-W;
 12.0" Radius, 2.0" Border, White on Green;
 State Highway 161 M1-6T3; "N ORTH", ClearviewHwy-5-W-R; "Lake Ridge Pkwy", ClearviewHwy-5-W-R;
 "1/4 MILE", ClearviewHwy-5-W-R;

SHEET 1 SIGN 7

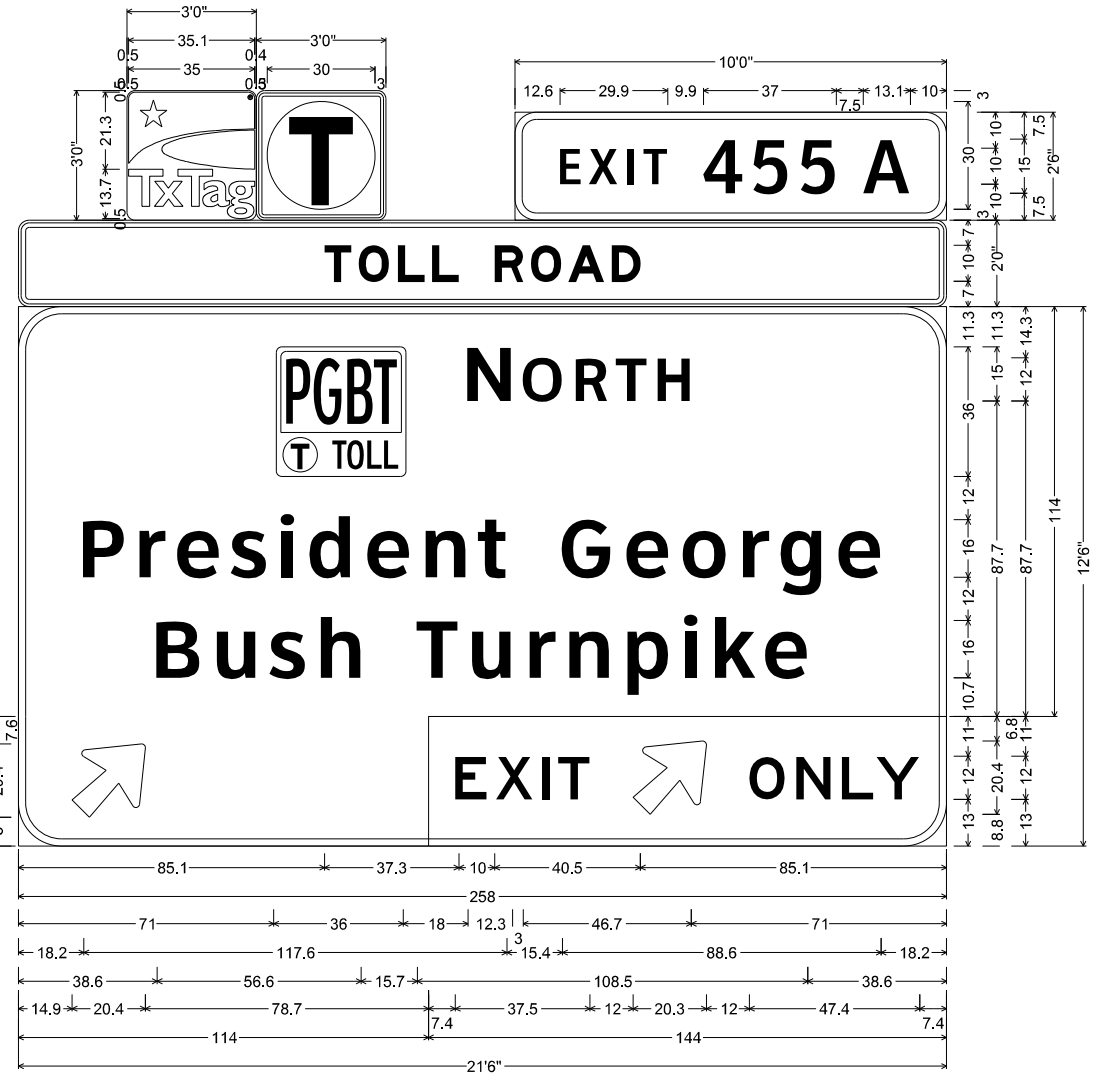

R91-1TP_36x36;
 2.3" Radius, No border, White;
 TxTag;
 2.3" Radius, 0.9" Border, 0.6" Indent, Black on White;
 NTTA Tolltag;
 6.0" Radius, 2.0" Border, White on Green;
 "EXIT 455 A", ClearviewHwy-4-W;
 W90-11T;
 3.0" Radius, 1.3" Border, 0.8" Indent, Black on White;
 "TOLL", E Mod; "ROAD", E Mod;
 12.0" Radius, 2.0" Border, White on Green;
 State Highway 161 M1-6T3; "N ORTH", ClearviewHwy-5-W-R; "President George", ClearviewHwy-5-W-R;
 "Bush Turnpike", ClearviewHwy-5-W-R;
 12.0" Radius, 2.0" Border, White on Green;
 Arrow B-3 - 25.0" 45";
 12.0" Radius, 2.0" Border, Black on Yellow;
 "EXIT", E; Arrow B-3 - 25.0" 45"; "ONLY", E;

SHEET 1 SIGN 8
SHEET 3 SIGN 1

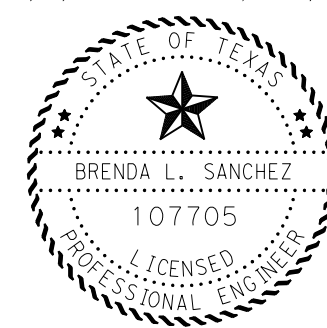

Brenda L Sanchez, P.E. 03/20/23
 Signature of Registrant & Date



GUIDE SIGN DETAILS

SCALE: NTS		SHEET 1 OF 47		
DESIGN/CK	FED. RD. DIV. NO.	STATE PROJECT NO.		
BLS	6	(SEE TITLE SHEET)		
CHECK	STATE	DISTRICT	COUNTY	
BLS	TEXAS	DAL	VARIOUS	
CHECK	CONTROL	SECTION	JOB	
MA	0095	14	033, ETC	
CHECK				226
BA				

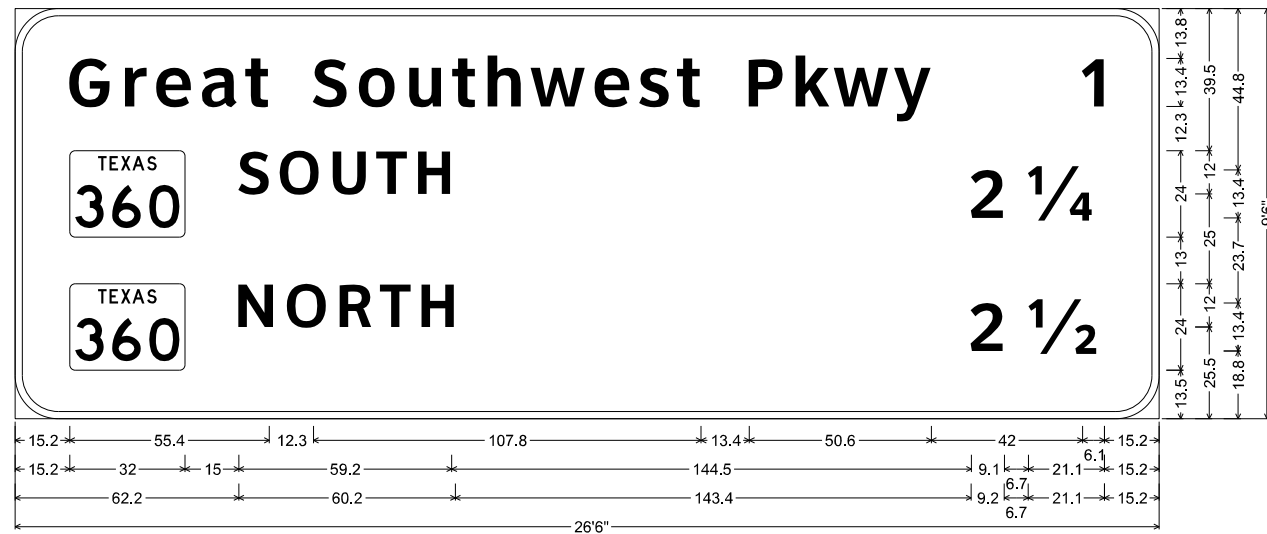

12.0" Radius, 2.0" Border, White on Green;
 "Great Southwest Pkwy", ClearviewHwy-5-W-R; "1", ClearviewHwy-5-W-R; State Highway 360 M1-6T3; "SOUTH", ClearviewHwy-5-W-R;
 "2 1/4", ClearviewHwy-5-W-R; State Highway 360 M1-6T3; "NORTH", ClearviewHwy-5-W-R; "2 1/2", ClearviewHwy-5-W-R;

SHEET 2 SIGN 2

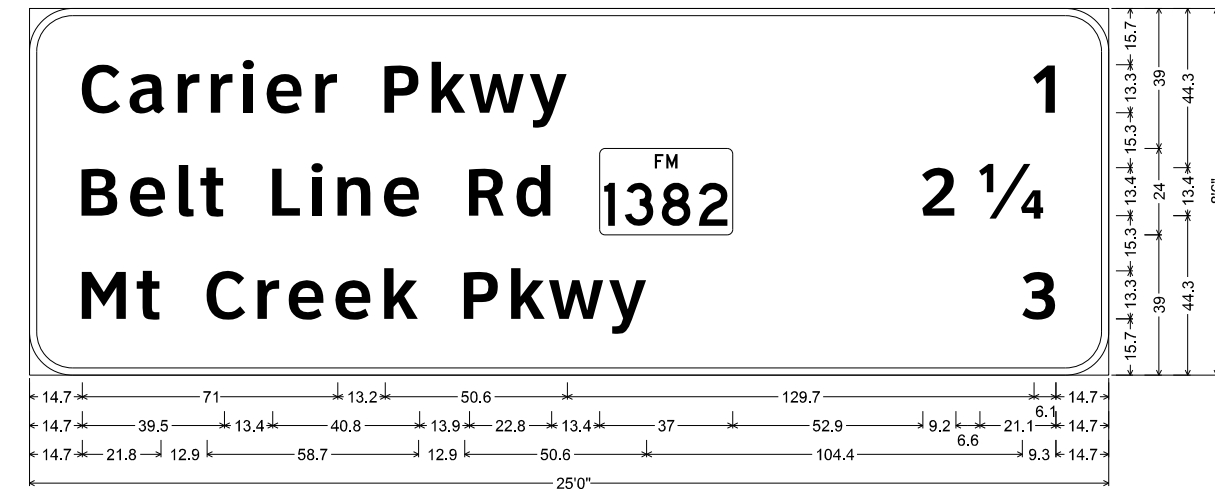

12.0" Radius, 2.0" Border, White on Green;
 "Carrier Pkwy", ClearviewHwy-5-W-R; "1", ClearviewHwy-5-W-R; "Belt Line Rd", ClearviewHwy-5-W-R; State Highway 1382 M1-6F4;
 "2 1/4", ClearviewHwy-5-W-R; "Mt Creek Pkwy", ClearviewHwy-5-W-R; "3", ClearviewHwy-5-W-R;

SHEET 2 OF SIGN 6

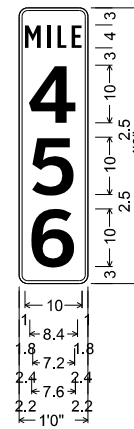

D10-3 10in;
 1.5" Radius, 0.5" Border, White on Green;
 "MILE", ClearviewHwy-2-W;
 "4", ClearviewHwy-6-W;
 "5", ClearviewHwy-6-W;
 "6", ClearviewHwy-6-W;

SHEET 2 SIGN 3
 SHEET 2 SIGN 4

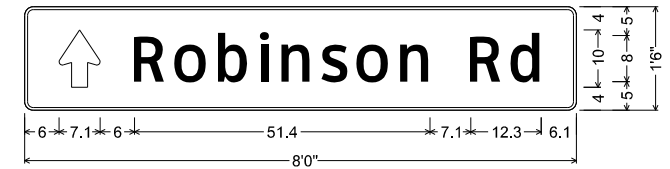

D1-1 8in UP;
 1.5" Radius, 0.5" Border, White on Green;
 Standard Arrow Custom 10.0" X 7.1" 90°;
 "Robnson Rd", ClearviewHwy-3-W;

SHEET 2 SIGN 7

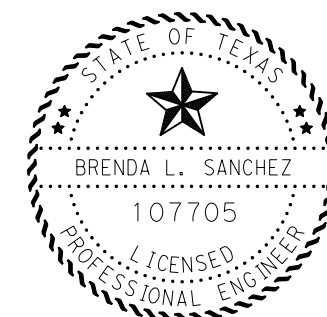

Brenda L Sanchez, P.E. 03/20/23
 Signature of Registrant & Date



GUIDE SIGN DETAILS

SCALE: NTS SHEET 2 OF 47

DESIGN/CK	FED. RD. DIV. NO.	STATE PROJECT NO.		HIGHWAY NO.
BLS	6	(SEE TITLE SHEET)		IH 20
CHECK	STATE	DISTRICT	COUNTY	SHEET NO.
BLS	TEXAS	DAL	VARIOUS	227
CHECK	CONTROL	SECTION	JOB	
BA	0095	14	033, ETC	

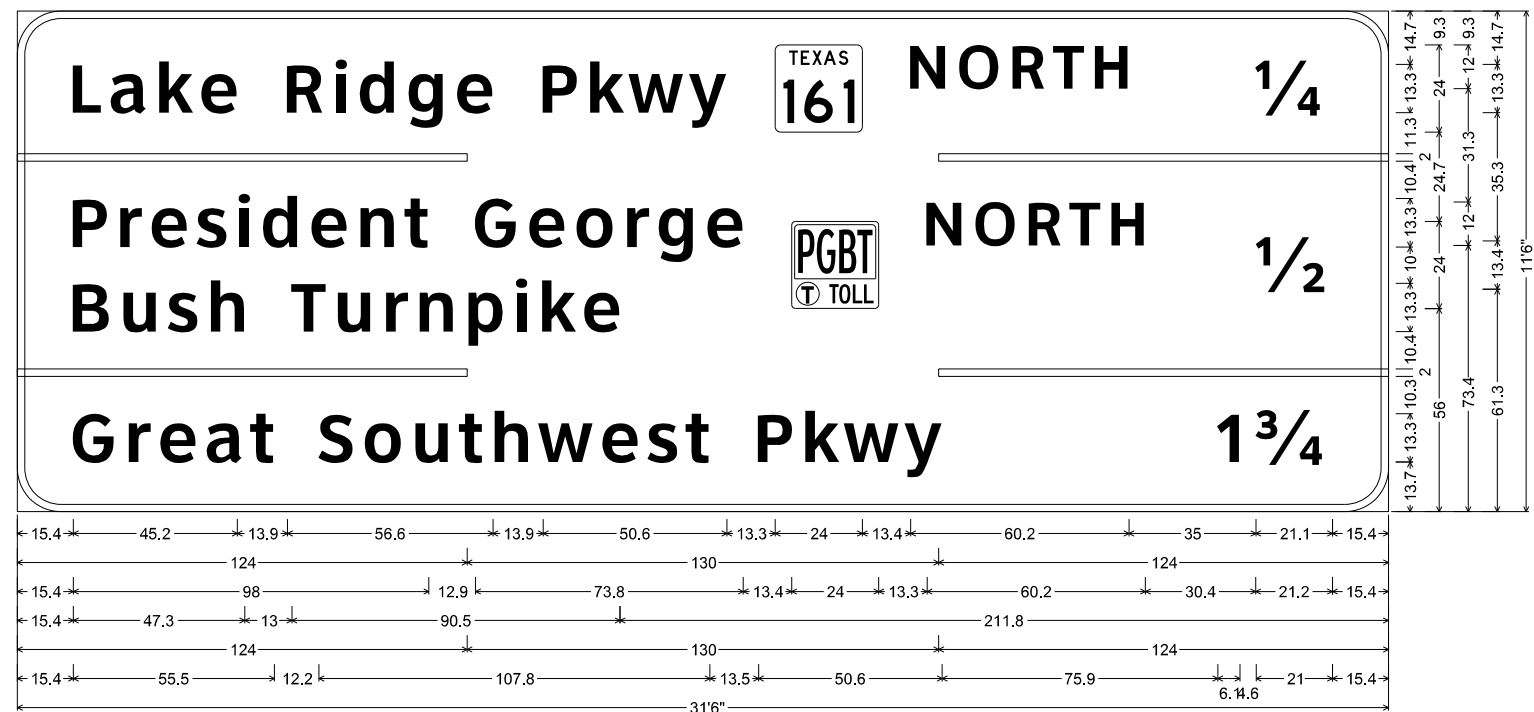

12.0" Radius, 2.0" Border, White on Green;
 "Lake Ridge Pkwy", ClearviewHwy-5-W-R; State Highway 161 M1-6T3; "NORTH", ClearviewHwy-5-W-R; "1/4", ClearviewHwy-5-W-R; "President George", ClearviewHwy-5-W-R;
 "Bush Turnpike", ClearviewHwy-5-W-R; State Highway 161 M1-6T3; "NORTH", ClearviewHwy-5-W-R; "1/2", ClearviewHwy-5-W-R;
 "Great Southwest Pkwy", ClearviewHwy-5-W-R; "1 3/4", ClearviewHwy-5-W-R;

SHEET 4 SIGN 1

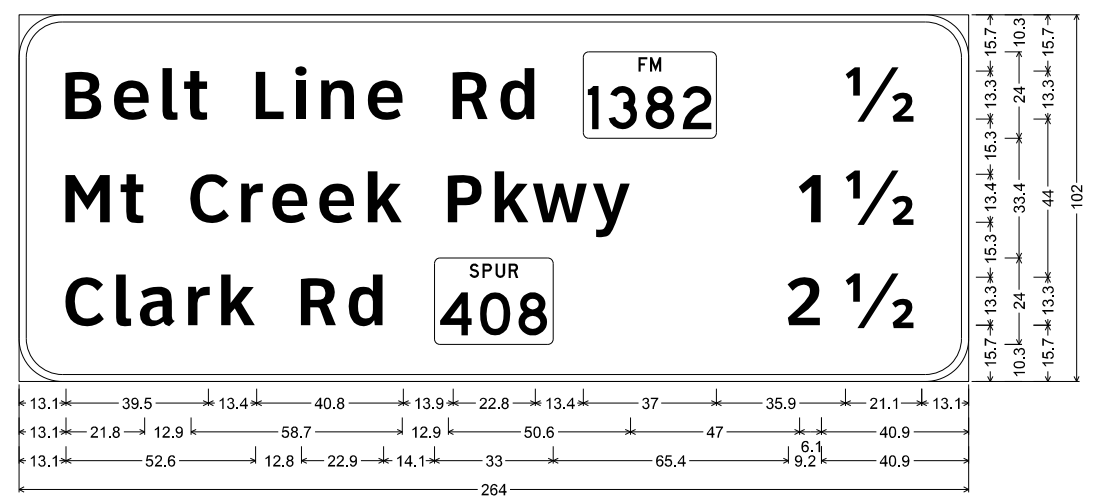

12.0" Radius, 2.0" Border, White on Green;
 "Belt Line Rd", ClearviewHwy-5-W-R; State Highway 1382 M1-6F4; "1/2", ClearviewHwy-5-W-R;
 "Mt Creek Pkwy", ClearviewHwy-5-W-R; "1 1/2", ClearviewHwy-5-W-R; "Clark Rd", ClearviewHwy-5-W-R;
 State Highway 408 M1-6S3; "2 1/2", ClearviewHwy-5-W-R;

SHEET 4 SIGN 2

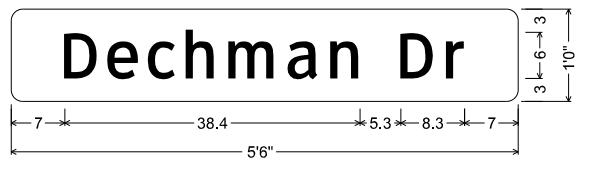

D3-1G(1) 6in;
 1.5" Radius, No border, White on Green;
 "Dechman Dr", ClearviewHwy-3-W;

SHEET 5 SIGN 1
 SHEET 5 SIGN 2

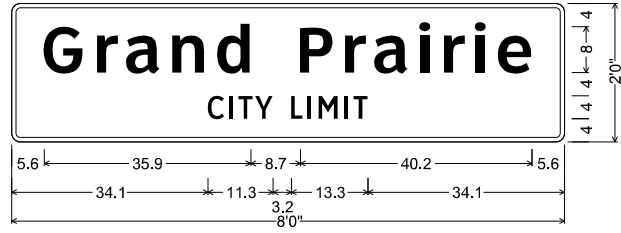

I-2aT 8in;
 1.5" Radius, 0.8" Border, White on Green;
 "Grand Prairie", ClearviewHwy-5-W-R;
 "CITY LIMIT", ClearviewHwy-3-W;

SHEET 6 SIGN 3

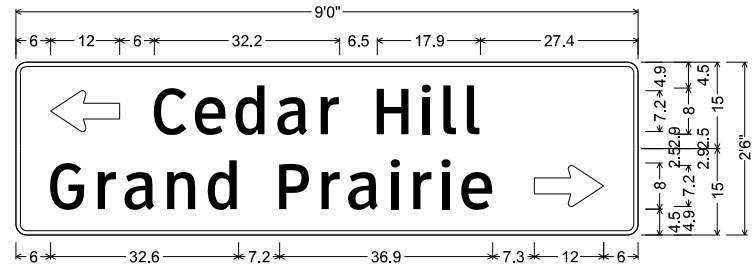

D1-2 8in LT-RT;
 1.9" Radius, 0.8" Border, White on Green;
 Standard Arrow Custom 12.0" X 7.1" 180"; "Cedar Hill", ClearviewHwy-3-W;
 1.9" Radius, 0.8" Border, White on Green;
 "Grand Prairie", ClearviewHwy-3-W; Standard Arrow Custom 12.0" X 7.1" 0°;

SHEET 6 SIGN 4



D1-2 8in LT-RT;
 1.9" Radius, 0.8" Border, White on Green;
 Standard Arrow Custom 12.0" X 7.1" 180"; "Grand Prairie", ClearviewHwy-3-W;
 1.9" Radius, 0.8" Border, White on Green;
 "Cedar Hill", ClearviewHwy-3-W; Standard Arrow Custom 12.0" X 7.1" 0°;

SHEET 6 SIGN 7

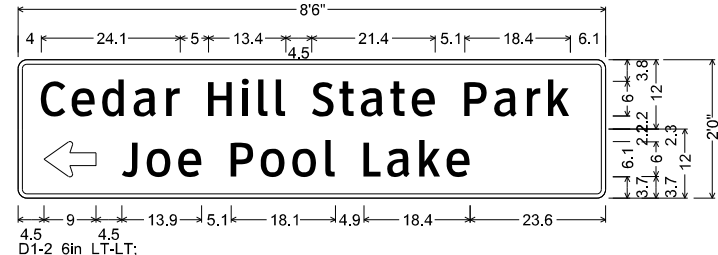

1.5" Radius, 0.8" Border, White on Brown;
 "Cedar Hill State Park", ClearviewHwy-3-W;
 1.5" Radius, 0.8" Border, White on Brown;
 Standard Arrow Custom 9.0" X 6.1" 180°;
 "Joe Pool Lake", ClearviewHwy-3-W;

SHEET 6 SIGN 5

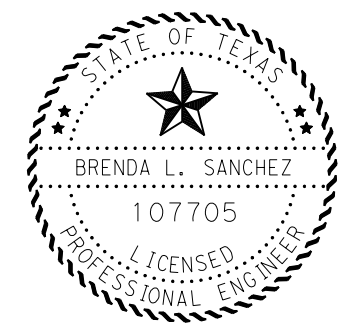

Brenda L Sanchez, P.E. 03/20/23
 Signature of Registrant & Date

<p>©2023</p>			
<h3>GUIDE SIGN DETAILS</h3>			
SCALE: NTS		SHEET 3 OF 47	
DESIGN/CK BLS	FED. RD. DIV. NO. 6	STATE PROJECT NO. (SEE TITLE SHEET)	HIGHWAY NO. IH 20
CHECK BLS	STATE	DISTRICT	COUNTY
CHECK MA	TEXAS	DAL	VARIOUS
CHECK BA	CONTROL	SECTION	JOB
			228
		0095	14 033, ETC

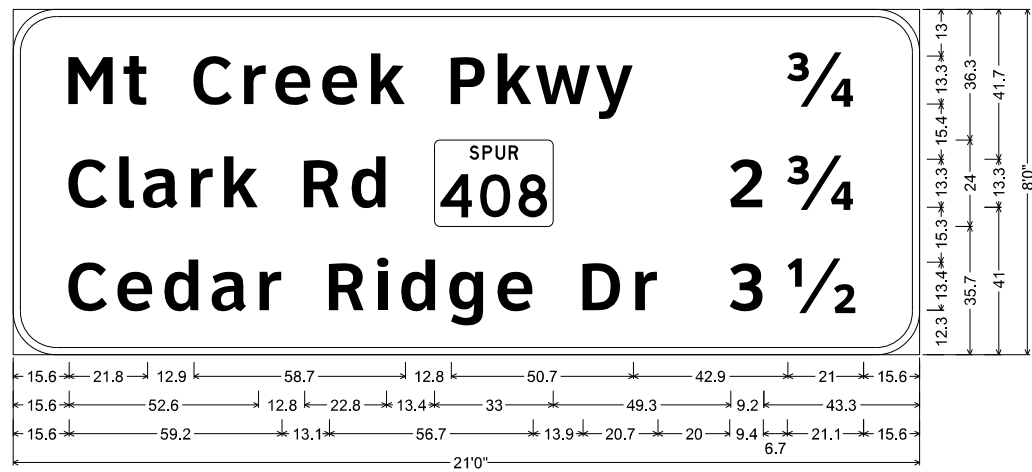

12.0" Radius, 2.0" Border, White on Green;
 "Mt Creek Pkwy", ClearviewHwy-5-W-R; "3/4", ClearviewHwy-5-W-R; "Clark Rd", ClearviewHwy-5-W-R;
 State Highway 408 M1-6S3; "2 3/4", ClearviewHwy-5-W-R; "Cedar Ridge Dr", ClearviewHwy-5-W-R;
 "3 1/2", ClearviewHwy-5-W-R;

SHEET 6 SIGN 6

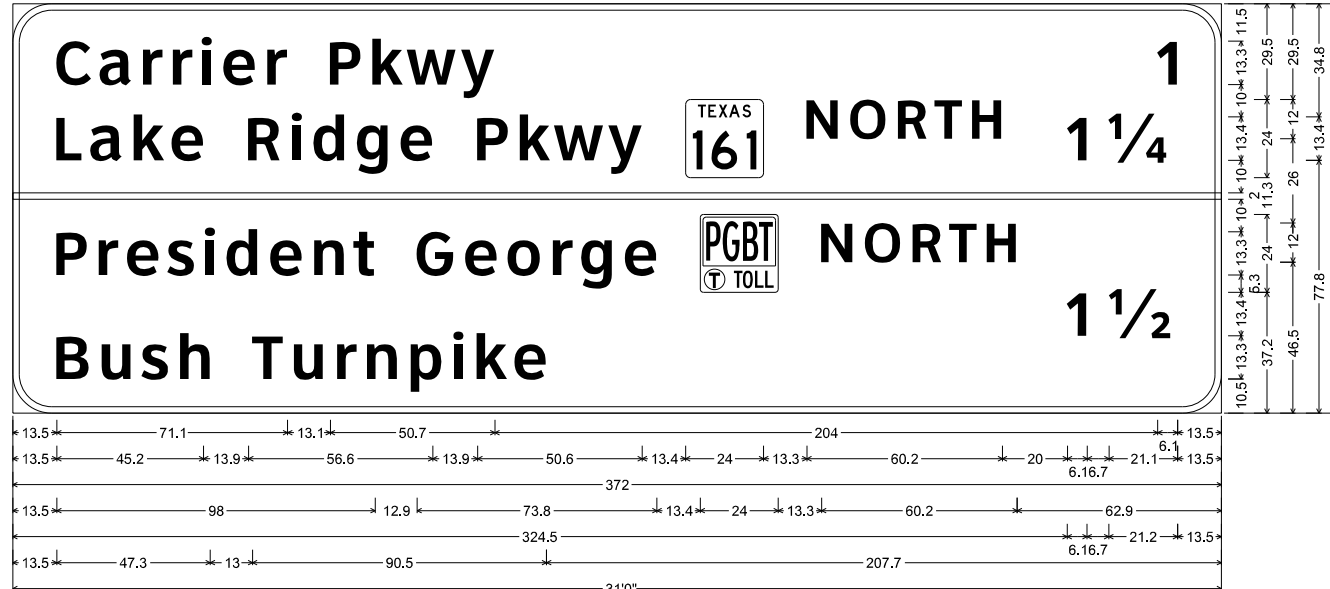

12.0" Radius, 2.0" Border, White on Green;
 "Carrier Pkwy", ClearviewHwy-5-W-R; "1", ClearviewHwy-5-W-R; "Lake Ridge Pkwy", ClearviewHwy-5-W-R; State Highway 161 M1-6T3; "NORTH", ClearviewHwy-5-W-R;
 "1 1/4", ClearviewHwy-5-W-R; "President George", ClearviewHwy-5-W-R; State Highway 161 M1-6T3; "NORTH", ClearviewHwy-5-W-R; "1 1/2", ClearviewHwy-5-W-R;
 "Bush Turnpike", ClearviewHwy-5-W-R;

SHEET 6 SIGN 8

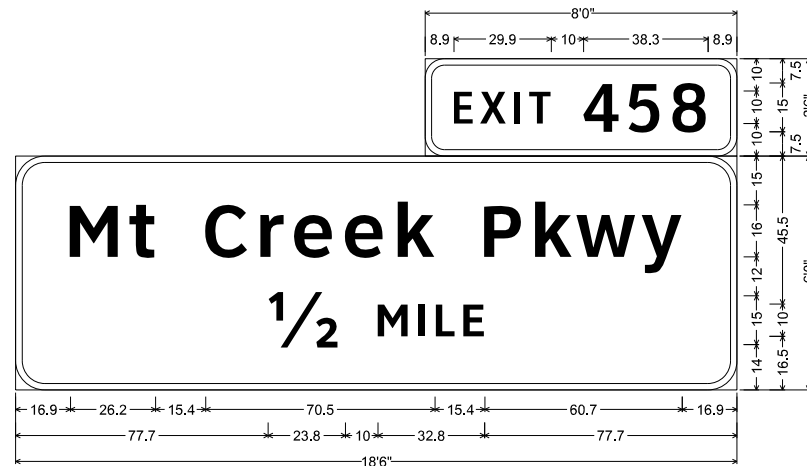

6.0" Radius, 2.0" Border, White on Green;
 "EXIT 458", ClearviewHwy-4-W;
 9.0" Radius, 2.0" Border, White on Green;
 "Mt Creek Pkwy", ClearviewHwy-5-W-R; "1/2 MILE", ClearviewHwy-5-W-R;

SHEET 6 SIGN 9
SHEET 9 SIGN 1

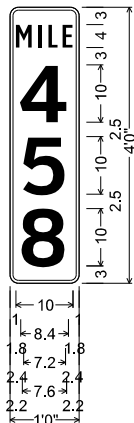

D10-3 10in;
 1.5" Radius, 0.5" Border, White on Green;
 "MILE", ClearviewHwy-2-W;
 "4", ClearviewHwy-6-W;
 "5", ClearviewHwy-6-W;
 "8", ClearviewHwy-6-W;

SHEET 6 SIGN 10
SHEET 6 SIGN 11

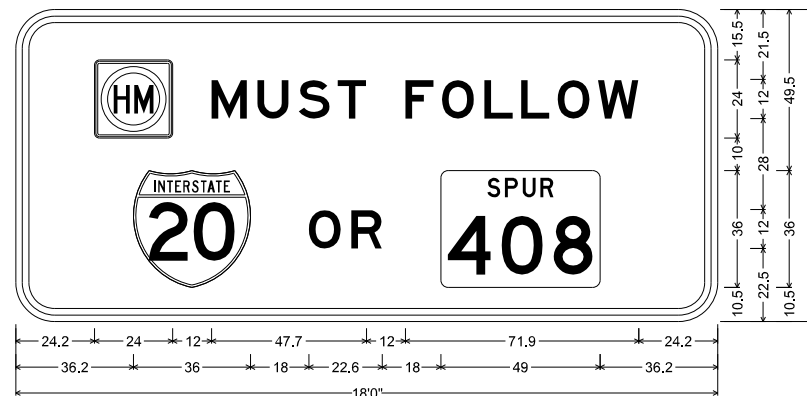

R14-6T_216x96;
 12.0" Radius, 2.0" Border, 2.0" Indent, Black on White;
 "MUST FOLLOW", E; Interstate 20 M1-1; "OR", E; State Highway 408 M1-6S3;

SHEET 6 SIGN 12

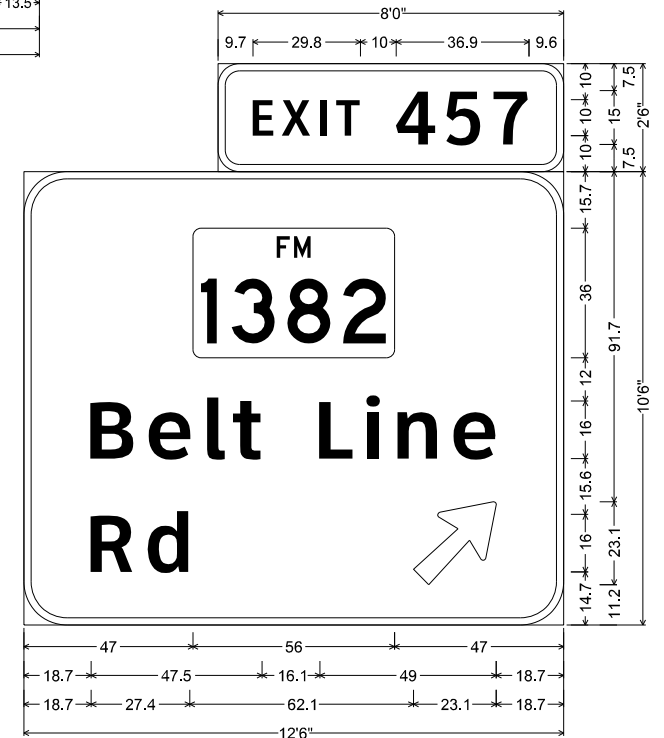

6.0" Radius, 2.0" Border, White on Green;
 "EXIT 457", ClearviewHwy-4-W;
 12.0" Radius, 2.0" Border, White on Green;
 State Highway 1382 M1-6F4; "Belt Line", ClearviewHwy-5-W-R;
 "Rd", ClearviewHwy-5-W-R; Arrow A-2 - 29.3" 45";

SHEET 7 SIGN 2

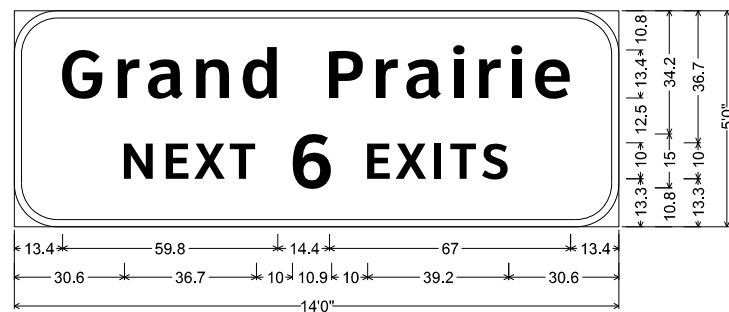

12.0" Radius, 2.0" Border, White on Green;
 "Grand Prairie", ClearviewHwy-5-W-R; "NEXT", ClearviewHwy-5-W-R;
 "6", ClearviewHwy-5-W-R; "EXITS", ClearviewHwy-5-W-R;

SHEET 7 SIGN 3

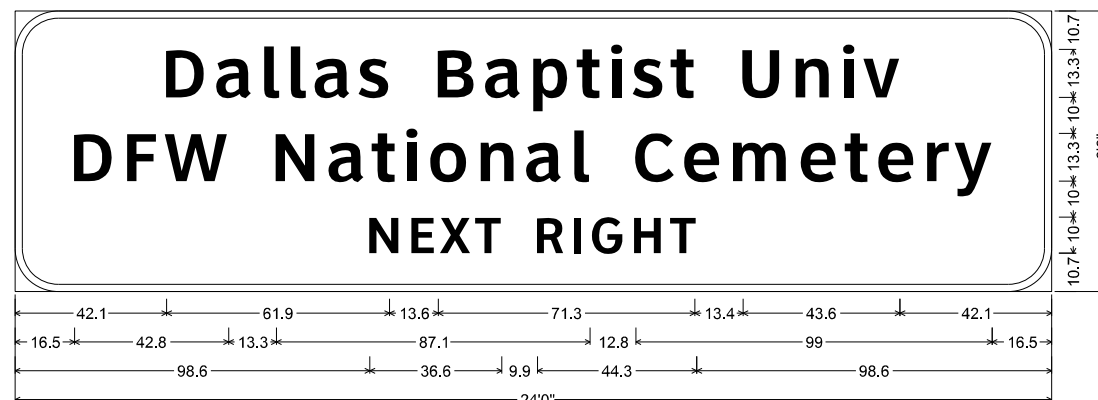

12.0" Radius, 2.0" Border, White on Green;
 "Dallas Baptist Univ", ClearviewHwy-5-W-R; "DFW National Cemetery", ClearviewHwy-5-W-R; "NEXT RIGHT", ClearviewHwy-5-W-R;

SHEET 7 SIGN 4

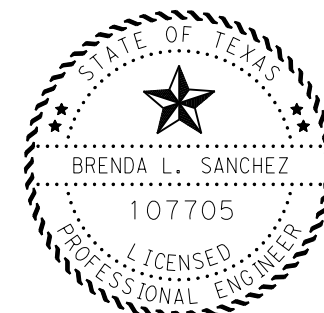

Brenda L Sanchez, P.E. 03/20/23
 Signature of Registrar & Date



GUIDE SIGN DETAILS

SCALE: NTS		SHEET 4 OF 47	
DESIGN/CK BLS	FED. RD. DIV. NO. 6	STATE PROJECT NO. (SEE TITLE SHEET)	HIGHWAY NO. IH 20
CHECK BLS	STATE	DISTRICT	COUNTY
CHECK MA	TEXAS	DAL	VARIOUS
CHECK BA	CONTROL	SECTION	JOB
			229
0095		14	033, ETC

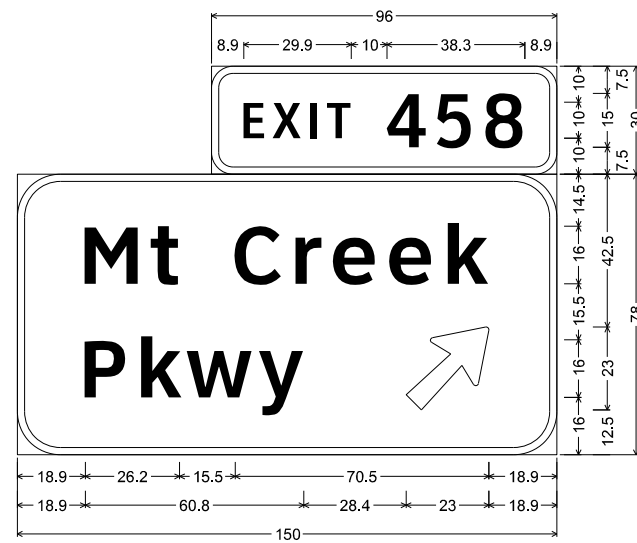

6.0" Radius, 2.0" Border, White on Green;
 "EXIT 458", ClearviewHwy-4-W;
 12.0" Radius, 2.0" Border, White on Green;
 "Mt Creek", ClearviewHwy-5-W-R; "Pkwy", ClearviewHwy-5-W-R;
 Arrow A-2 - 29.3" 45°;

SHEET 7 SIGN 6
 SHEET 8 SIGN 6

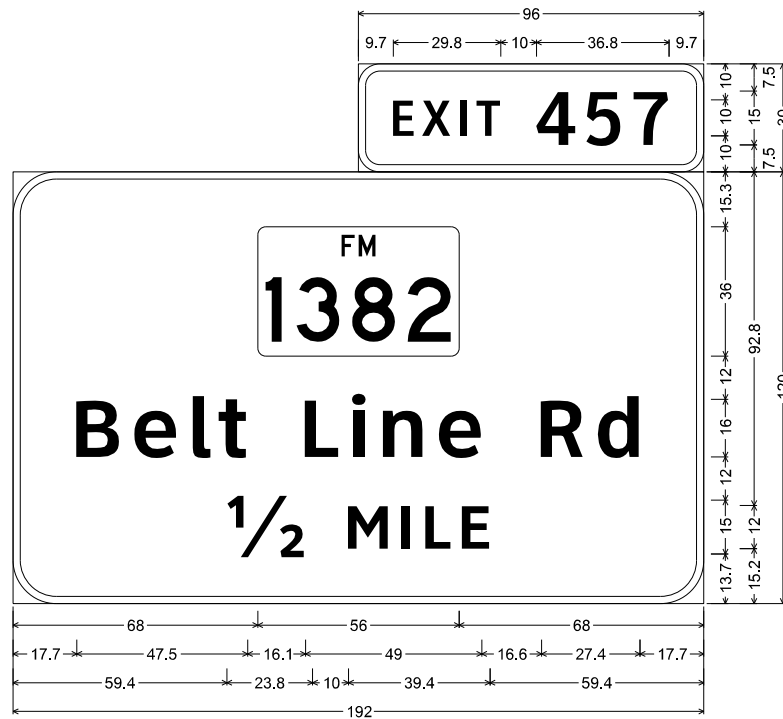

6.0" Radius, 2.0" Border, White on Green;
 "EXIT 457", ClearviewHwy-4-W;
 12.0" Radius, 2.0" Border, White on Green;
 State Highway 1382 M1-6F4; "Belt Line Rd", ClearviewHwy-5-W-R;
 "1/2", ClearviewHwy-5-W-R; "MILE", ClearviewHwy-5-W-R;

SHEET 8 SIGN 1

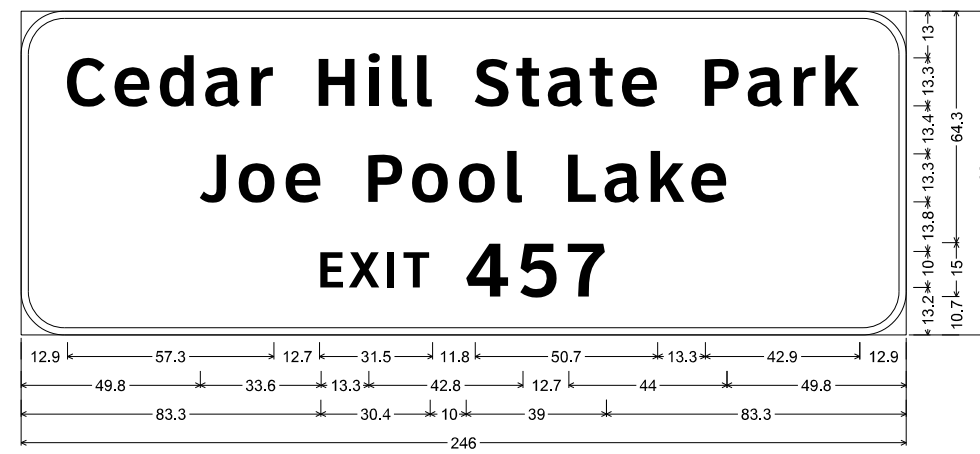

12.0" Radius, 2.0" Border, White on Brown;
 "Cedar Hill State Park", ClearviewHwy-5-W-R 85% spacing; "Joe Pool Lake", ClearviewHwy-5-W-R 85% spacing;
 "EXIT", ClearviewHwy-5-W-R; "457", ClearviewHwy-5-W-R;

SHEET 8 SIGN 3

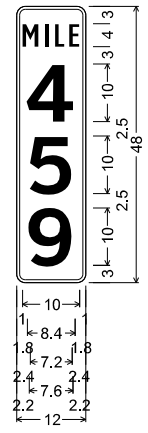

D10-3 10in;
 1.5" Radius, 0.5" Border, White on Green;
 "MILE", ClearviewHwy-2-W;
 "4", ClearviewHwy-6-W;
 "5", ClearviewHwy-6-W;
 "9", ClearviewHwy-6-W;

SHEET 8 SIGN 5
 SHEET 8 SIGN 10



D1-2 8in LT-LT;
 1.9" Radius, 0.8" Border, White on Green;
 Standard Arrow Custom 12.0" X 7.1" 180°; "Dallas Baptist Univ", ClearviewHwy-3-W;
 1.9" Radius, 0.8" Border, White on Green;
 Standard Arrow Custom 12.0" X 7.1" 180°; "DFW National Cemetery", ClearviewHwy-3-W;

SHEET 8 SIGN 8

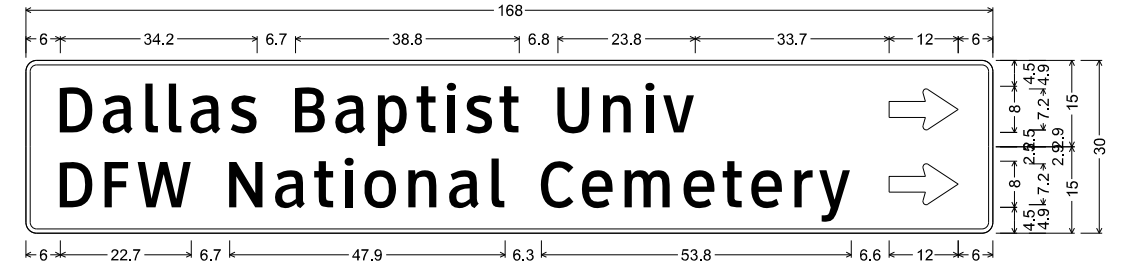

D1-2 8in RT-RT;
 1.9" Radius, 0.8" Border, White on Green;
 "Dallas Baptist Univ", ClearviewHwy-3-W; Standard Arrow Custom 12.0" X 7.1" 0°;
 1.9" Radius, 0.8" Border, White on Green;
 "DFW National Cemetery", ClearviewHwy-3-W; Standard Arrow Custom 12.0" X 7.1" 0°;

SHEET 8 SIGN 2

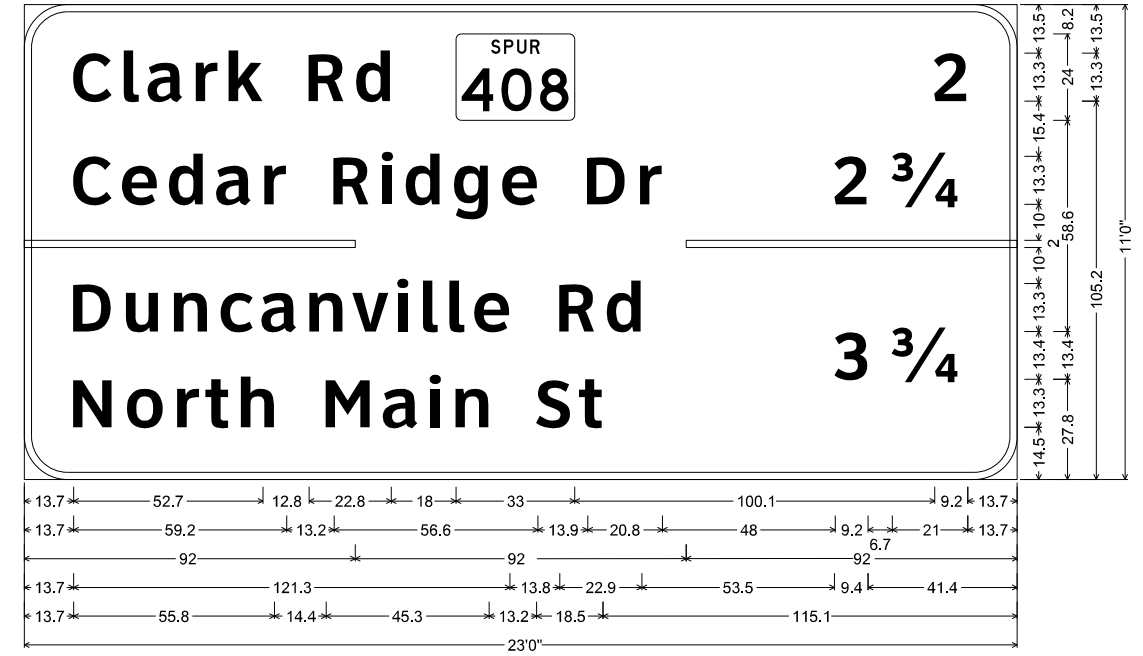

12.0" Radius, 2.0" Border, White on Green;
 "Clark Rd", ClearviewHwy-5-W-R; State Highway 408 M1-6S3; "2", ClearviewHwy-5-W-R;
 "Cedar Ridge Dr", ClearviewHwy-5-W-R; "2 3/4", ClearviewHwy-5-W-R; "Duncanville Rd", ClearviewHwy-5-W-R;
 "North Main St", ClearviewHwy-5-W-R; "3 3/4", ClearviewHwy-5-W-R;

SHEET 8 SIGN 7



Brenda L Sanchez, P.E. 03/20/23
 Signature of Registrant & Date

			
© 2023			
GUIDE SIGN DETAILS			
SCALE: NTS		SHEET 5 OF 47	
DESIGN/CK BLS	FED. RD. DIV. NO. 6	STATE PROJECT NO. (SEE TITLE SHEET)	
CHECK BLS	STATE	DISTRICT DAL	COUNTY VARIOUS
CHECK MA	TEXAS	CONTROL SECTION	
CHECK BA	0095	14	JOB 033, ETC
			HIGHWAY NO. IH 20 SHEET NO. 230

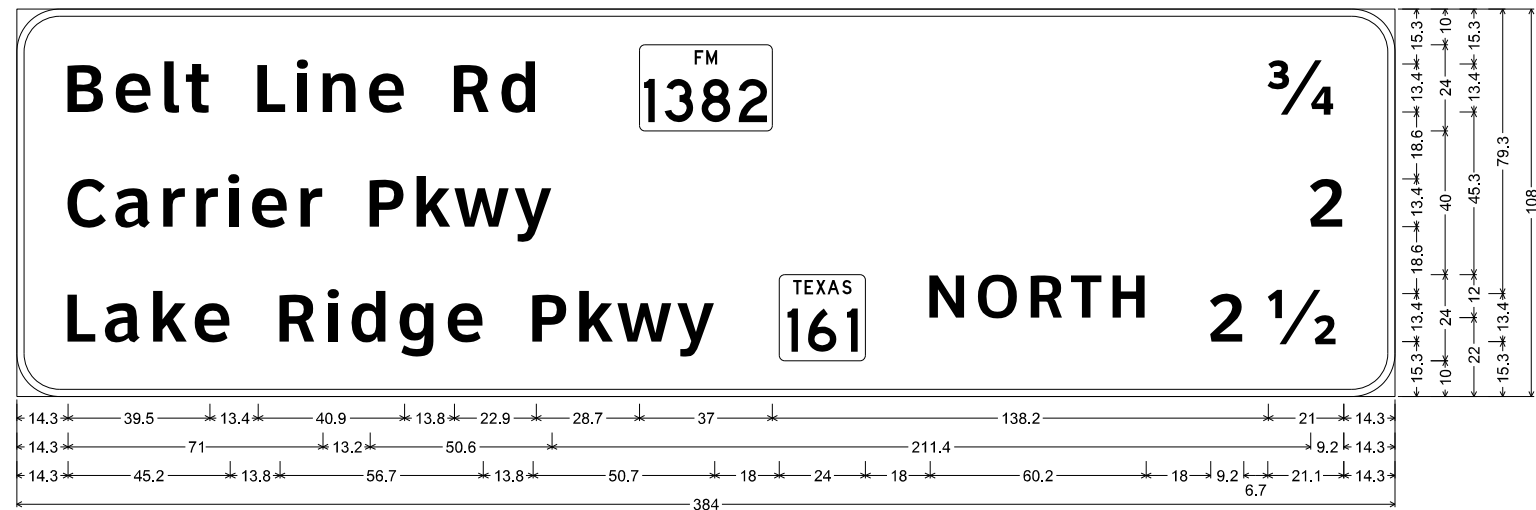

12.0" Radius, 2.0" Border, White on Green;
 "Belt Line Rd", ClearviewHwy-5-W-R; State Highway 1382 M1-6F4; "3/4", ClearviewHwy-5-W-R; "Carrier Pkwy", ClearviewHwy-5-W-R; "2", ClearviewHwy-5-W-R;
 "Lake Ridge Pkwy", ClearviewHwy-5-W-R; State Highway 161 M1-6T3; "NORTH", ClearviewHwy-5-W-R; "2 1/2", ClearviewHwy-5-W-R;

SHEET 8 SIGN 9

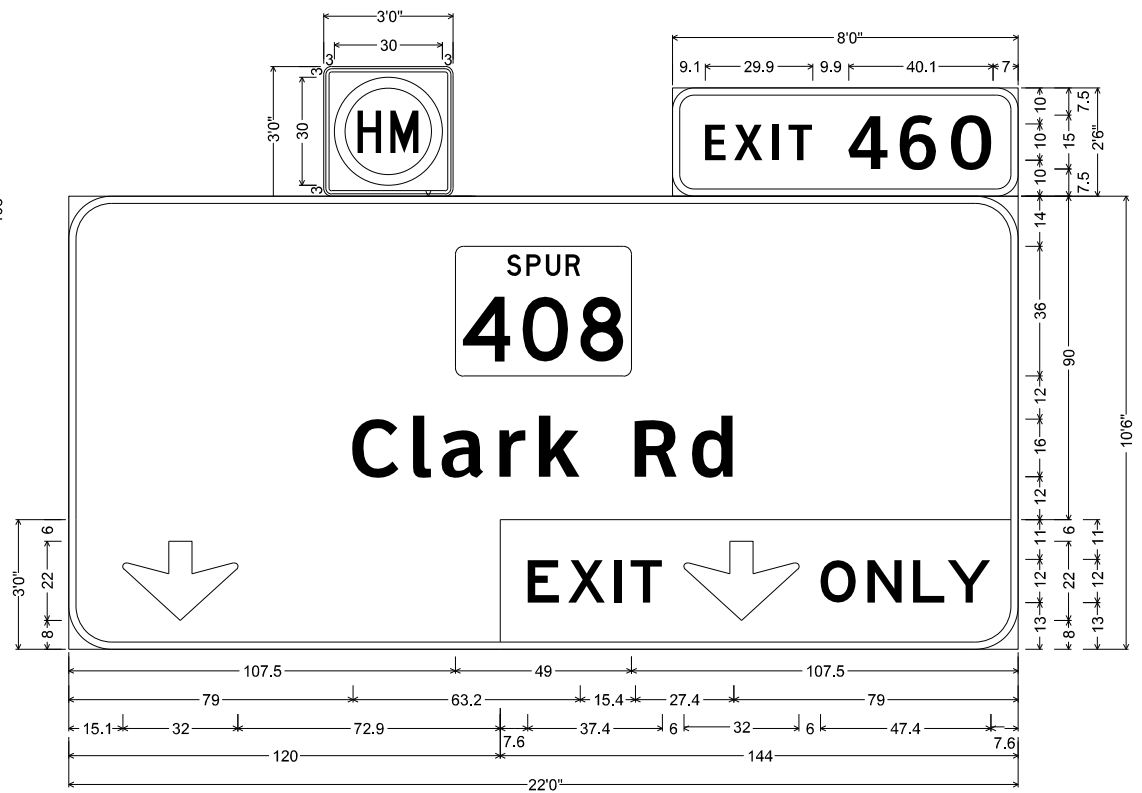

R14-2_36x36;
 2.3" Radius, 0.9" Border, 0.6" Indent, Black on White;
 6.0" Radius, 2.0" Border, White on Green;
 "EXIT 460", ClearviewHwy-4-W;
 12.0" Radius, 2.0" Border, White on Green;
 State Highway 408 M1-6S3; "Clark Rd", ClearviewHwy-5-W-R;
 12.0" Radius, 2.0" Border, White on Green;
 Down Arrow 22 - 22.0" 270°;
 E11-1dT;
 12.0" Radius, 2.0" Border, Black on Yellow;
 "EXIT", E; Down Arrow 22 - 22.0" 270°; "ONLY", E;

SHEET 9 SIGN 2
 SHEET 9 SIGN 3

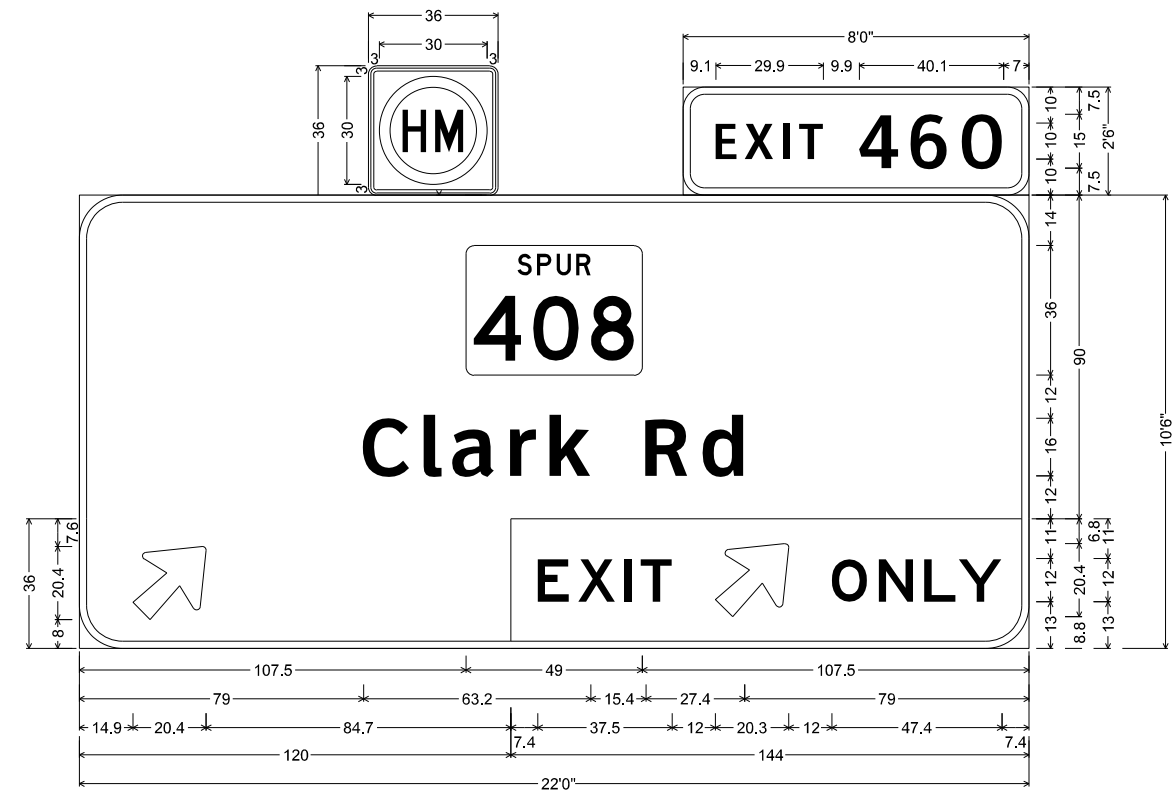

R14-2_36x36;
 2.3" Radius, 0.9" Border, 0.6" Indent, Black on White;
 6.0" Radius, 2.0" Border, White on Green;
 "EXIT 460", ClearviewHwy-4-W;
 12.0" Radius, 2.0" Border, White on Green;
 State Highway 408 M1-6S3; "Clark Rd", ClearviewHwy-5-W-R;
 12.0" Radius, 2.0" Border, White on Green;
 Arrow B-3 - 25.0" 45°;
 12.0" Radius, 2.0" Border, Black on Yellow;
 "EXIT", E; Arrow B-3 - 25.0" 45°; "ONLY", E;

SHEET 9 SIGN 4

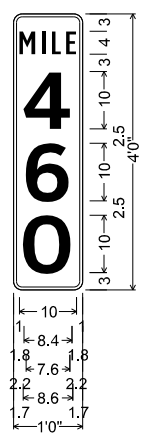

D10-3 10In;
 1.5" Radius, 0.5" Border, White on Green;
 "MILE", ClearviewHwy-2-W;
 "4", ClearviewHwy-6-W;
 "6", ClearviewHwy-6-W;
 "0", ClearviewHwy-6-W;

SHEET 10 SIGN 1
 SHEET 10 SIGN 2

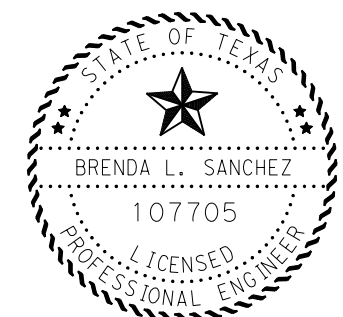

Brenda L Sanchez, P.E. 03/20/23
 Signature of Registrant & Date

© 2023			
GUIDE SIGN DETAILS			
SCALE: NTS		SHEET 6 OF 47	
DESIGN/CK BLS	FED. RD. DIV. NO. 6	STATE PROJECT NO. (SEE TITLE SHEET)	
CHECK BLS	STATE	DISTRICT DAL	COUNTY VARIOUS
CHECK MA	TEXAS	SECTION CONTROL	JOB VARIOUS
CHECK BA	0095	14	033, ETC
			HIGHWAY NO. IH 20 SHEET NO. 231

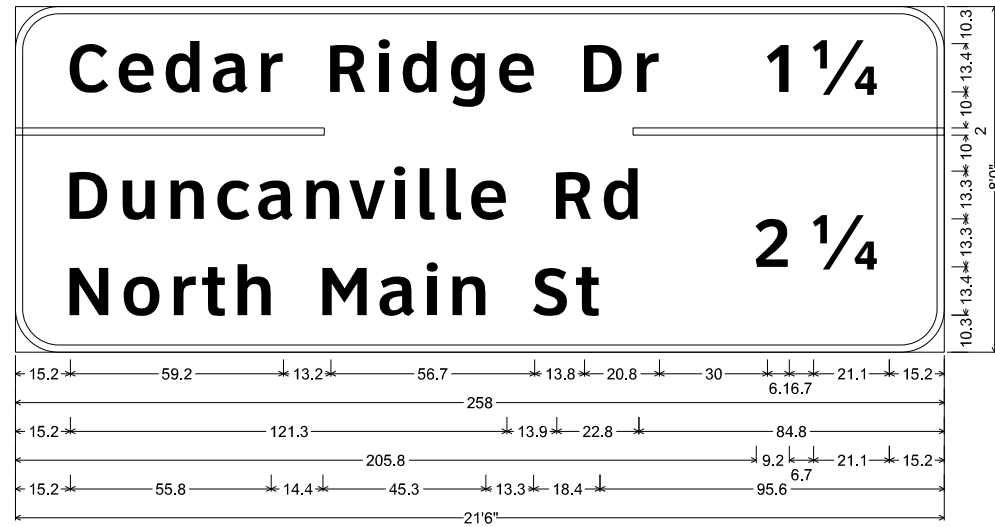

12.0" Radius, 2.0" Border, White on Green;
 "Cedar Ridge Dr", ClearviewHwy-5-W-R; "1 1/4", ClearviewHwy-5-W-R; "Duncanville Rd", ClearviewHwy-5-W-R;
 "2 1/4", ClearviewHwy-5-W-R; "North Main St", ClearviewHwy-5-W-R;

SHEET 10 SIGN 3

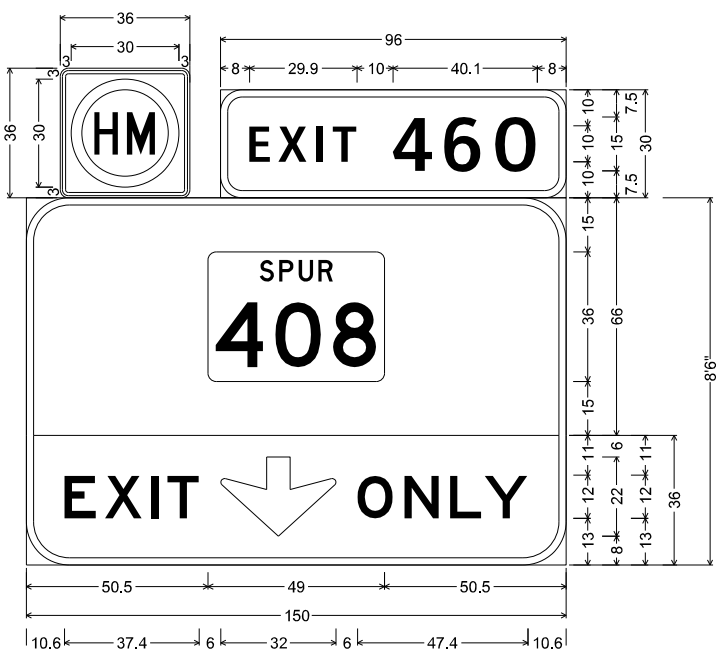

R14-2_36x36;
 2.3" Radius, 0.9" Border, 0.6" Indent, Black on White;
 6.0" Radius, 2.0" Border, White on Green;
 "EXIT 460", ClearviewHwy-4-W;
 12.0" Radius, 2.0" Border, White on Green;
 State Highway 408 M1-6S3;
 12.0" Radius, 2.0" Border, Black on Yellow;
 "EXIT", E; Down Arrow 22 - 22.0" 270"; "ONLY", E;

SHEET 12 SIGN 1

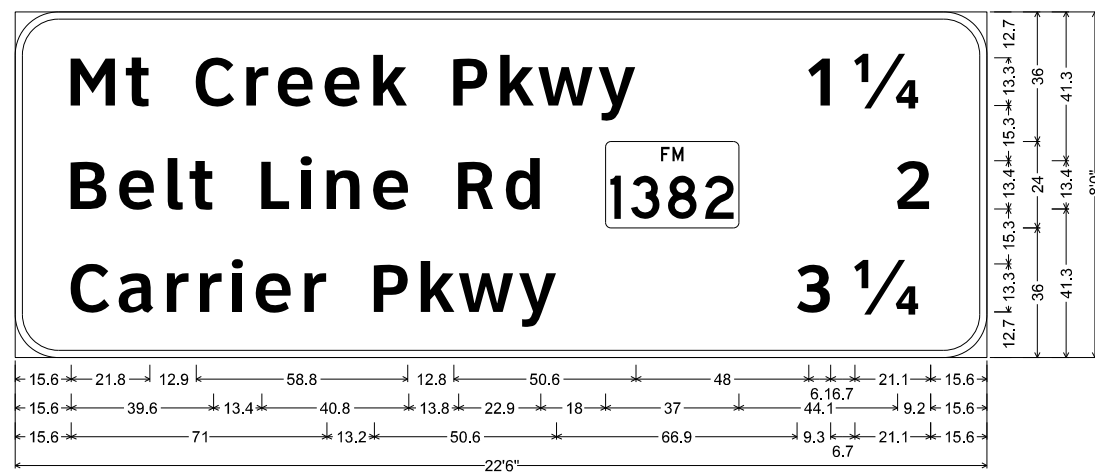

12.0" Radius, 2.0" Border, White on Green;
 "Mt Creek Pkwy", ClearviewHwy-5-W-R; "1 1/4", ClearviewHwy-5-W-R; "Belt Line Rd", ClearviewHwy-5-W-R;
 State Highway 1382 M1-6F4; "2", ClearviewHwy-5-W-R; "Carrier Pkwy", ClearviewHwy-5-W-R; "3 1/4", ClearviewHwy-5-W-R;

SHEET 11 SIGN 1

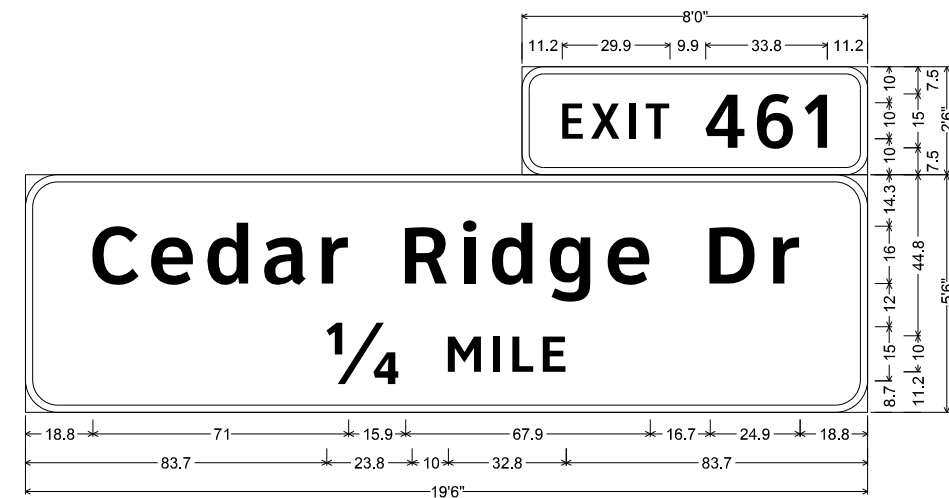

6.0" Radius, 2.0" Border, White on Green;
 "EXIT 461", ClearviewHwy-4-W;
 9.0" Radius, 2.0" Border, White on Green;
 "Cedar Ridge Dr", ClearviewHwy-5-W-R; "1/4 MILE", ClearviewHwy-5-W-R;

SHEET 12 SIGN 2
SHEET 12 SIGN 5

SHEET 12 SIGN 3
SHEET 14 SIGN 2

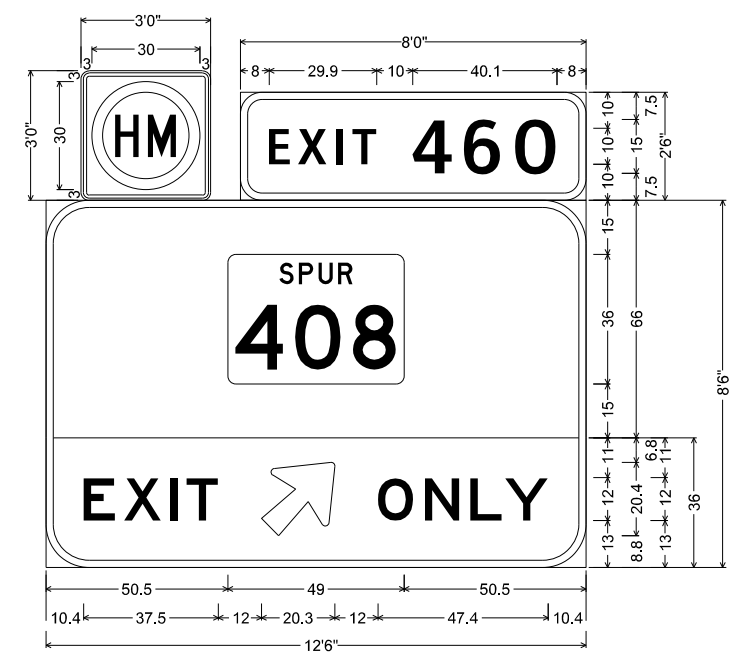

R14-2_36x36;
 2.3" Radius, 0.9" Border, 0.6" Indent, Black on White;
 6.0" Radius, 2.0" Border, White on Green;
 "EXIT 460", ClearviewHwy-4-W;
 12.0" Radius, 2.0" Border, White on Green;
 State Highway 408 M1-6S3;
 12.0" Radius, 2.0" Border, Black on Yellow;
 "EXIT", E; Arrow B-3 - 25.0" 45"; "ONLY", E;

SHEET 11 SIGN 3

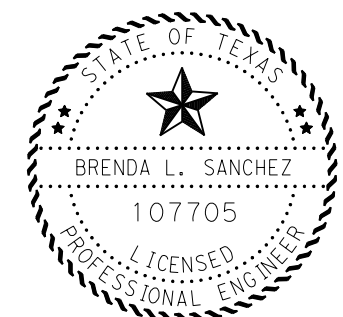

Brenda L Sanchez, P.E. 03/20/23
 Signature of Registrant & Date

 © 2023			
GUIDE SIGN DETAILS			
SCALE: NTS		SHEET 7 OF 47	
DESIGN/CK BLS	FED. RD. DIV. NO. 6	STATE PROJECT NO. (SEE TITLE SHEET)	HIGHWAY NO. IH 20
CHECK BLS	STATE	DISTRICT DAL	COUNTY VARIOUS
CHECK MA	TEXAS	SECTION	JOB
CHECK BA	CONTROL 0095	SECTION 14	JOB 033, ETC
			232

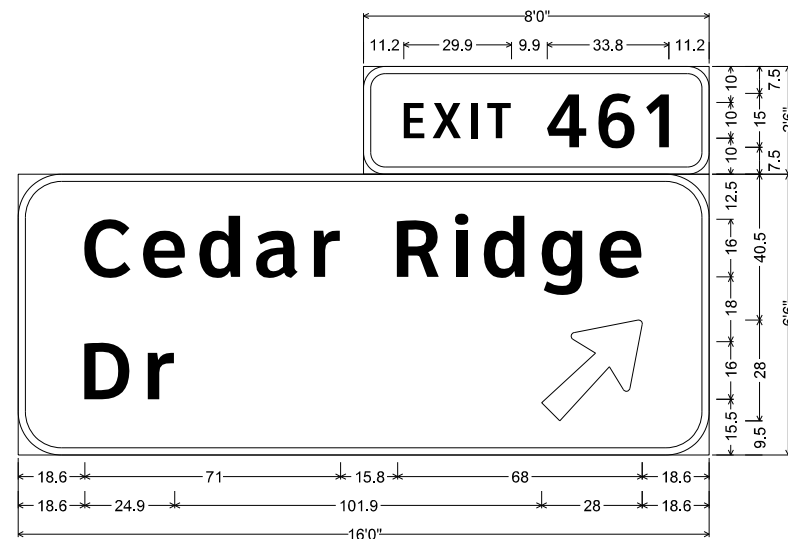

6.0" Radius, 2.0" Border, White on Green;
 "EXIT 461", ClearviewHwy-4-W;
 12.0" Radius, 2.0" Border, White on Green;
 "Cedar Ridge", ClearviewHwy-5-W-R; "Dr", ClearviewHwy-5-W-R; Arrow A-3 - 35.6" 45";

SHEET 12 SIGN 4
 SHEET 13 SIGN 7

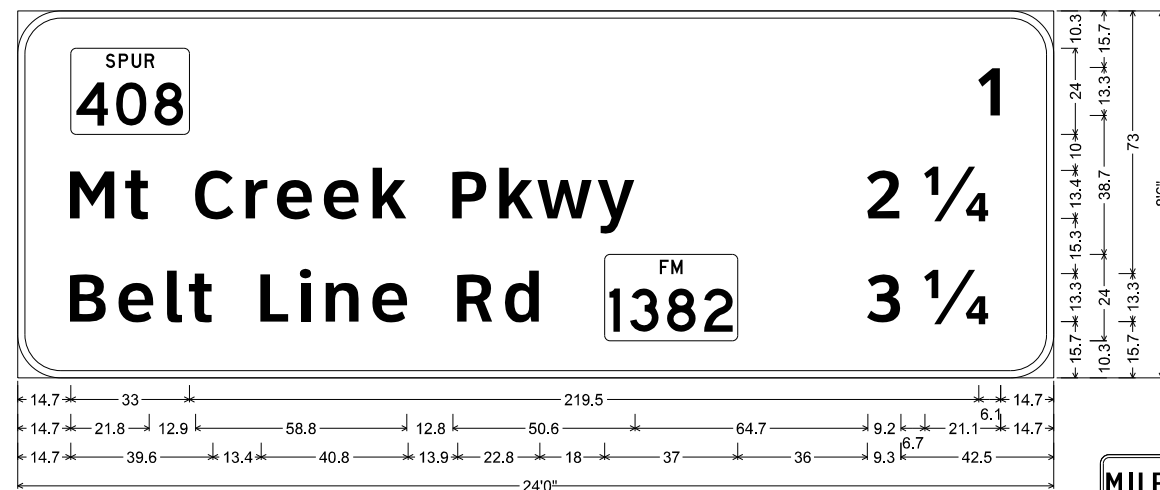

12.0" Radius, 2.0" Border, White on Green;
 State Highway 408 M1-6S3; "1", ClearviewHwy-5-W-R; "Mt Creek Pkwy", ClearviewHwy-5-W-R; "2 1/4", ClearviewHwy-5-W-R;
 "Belt Line Rd", ClearviewHwy-5-W-R; State Highway 1382 M1-6F4; "3 1/4", ClearviewHwy-5-W-R;

SHEET 13 SIGN 5

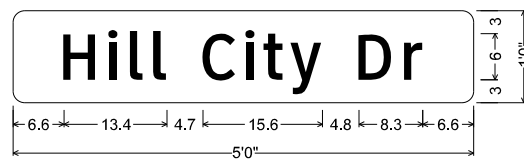

D3-1G(1) 6in;
 1.5" Radius, No border, White on Green;
 "Hill City Dr", ClearviewHwy-3-W;

SHEET 14 SIGN 1
 SHEET 14 SIGN 6



D3-1G(1) 6in;
 1.5" Radius, No border, White on Green;
 "Cedar Ridge", ClearviewHwy-3-W;

SHEET 13 SIGN 2
 SHEET 13 SIGN 4

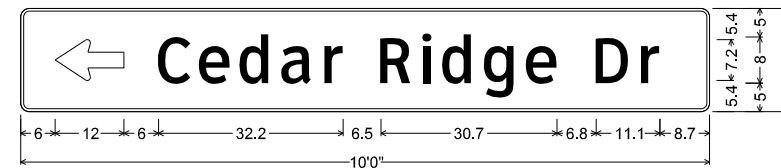

D1-1 8in LT;
 1.5" Radius, 0.5" Border, White on Green;
 Standard Arrow Custom 12.0" X 7.1" 180"; "Cedar Ridge Dr", ClearviewHwy-3-W;

SHEET 13 SIGN 3

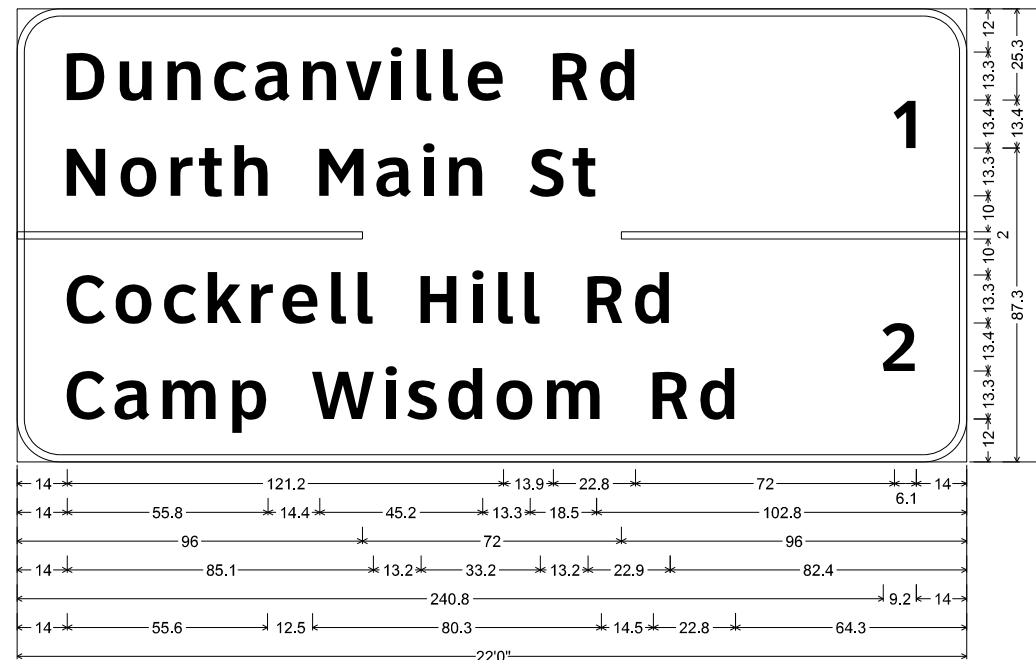

12.0" Radius, 2.0" Border, White on Green;
 "Duncanville Rd", ClearviewHwy-5-W-R; "North Main St", ClearviewHwy-5-W-R; "1", ClearviewHwy-5-W-R;
 "Cockrell Hill Rd", ClearviewHwy-5-W-R; "2", ClearviewHwy-5-W-R; "Camp Wisdom Rd", ClearviewHwy-5-W-R;

SHEET 13 SIGN 8

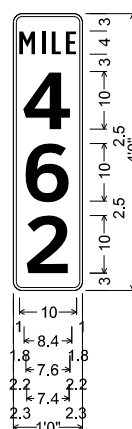

D10-3 10in;
 1.5" Radius, 0.5" Border, White on Green;
 "MILE", ClearviewHwy-2-W;
 "4", ClearviewHwy-6-W;
 "6", ClearviewHwy-6-W;
 "2", ClearviewHwy-6-W;

SHEET 14 SIGN 3
 SHEET 14 SIGN 4

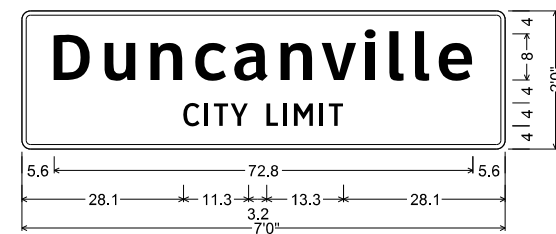

I-2aT 8in;
 1.5" Radius, 0.8" Border, White on Green;
 "Duncanville", ClearviewHwy-5-W-R;
 "CITY LIMIT", ClearviewHwy-3-W;

SHEET 13 SIGN 9
 SHEET 17 SIGN 1

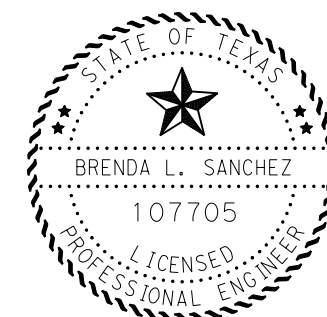

Brenda L Sanchez, P.E. 03/20/23
 Signature of Registrant & Date

 © 2023			
GUIDE SIGN DETAILS			
SCALE: NTS		SHEET 8 OF 47	
DESIGN/CK BLS	FED. RD. DIV. NO. 6	STATE PROJECT NO. (SEE TITLE SHEET)	HIGHWAY NO. IH 20
CHECK BLS	STATE	DISTRICT DAL	COUNTY VARIOUS
CHECK MA	TEXAS	SECTION	JOB
CHECK BA	CONTROL 0095	SECTION 14	JOB 033, ETC
			233

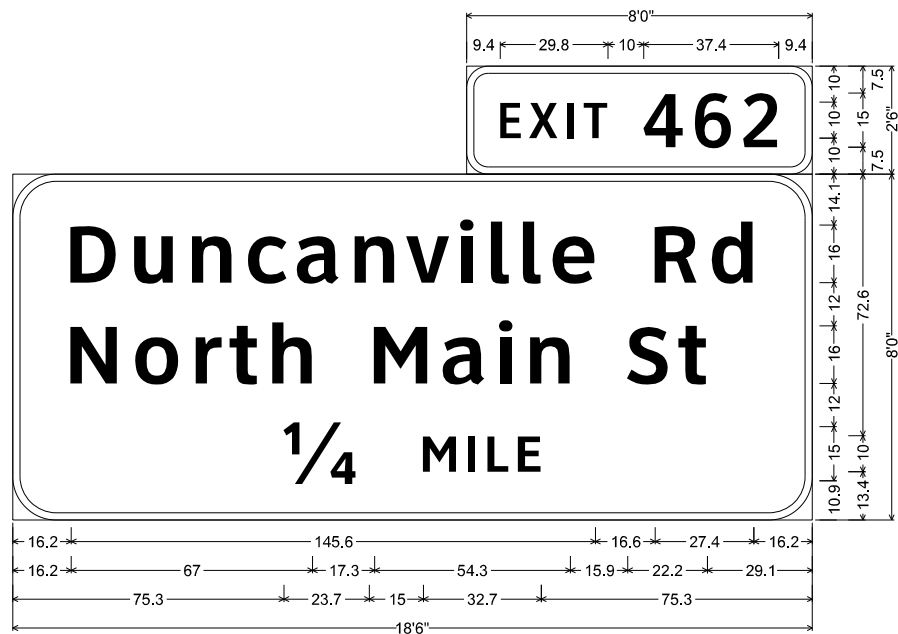

6.0" Radius, 2.0" Border, White on Green;
 "EXIT 462", ClearviewHwy-4-W;
 SHEET 14 SIGN 5

12.0" Radius, 2.0" Border, White on Green;
 "Duncanville Rd", ClearviewHwy-5-W-R; "North Main St", ClearviewHwy-5-W-R;
 "1/4", ClearviewHwy-5-W-R; "MILE", ClearviewHwy-5-W-R;

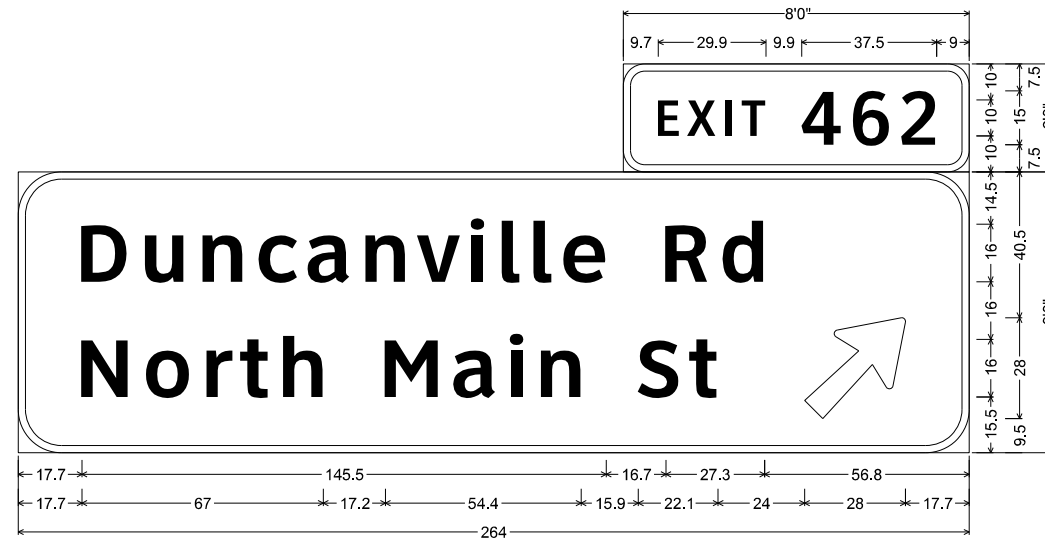

6.0" Radius, 2.0" Border, White on Green;
 "EXIT 462", ClearviewHwy-4-W;
 SHEET 14 SIGN 7

12.0" Radius, 2.0" Border, White on Green;
 "Duncanville Rd", ClearviewHwy-5-W-R; "North Main St", ClearviewHwy-5-W-R; Arrow A-3 - 35.6" 45";



D3-1G(1) 6in;
 1.5" Radius, No border, White on Green;
 "Duncanville Rd", ClearviewHwy-3-W;
 SHEET 15 SIGN 1
 SHEET 15 SIGN 7



D1-1 8in UP;
 1.5" Radius, 0.5" Border, White on Green;
 Standard Arrow Custom 10.0" X 7.1" 90"; "Duncanville Rd", ClearviewHwy-3-W;

SHEET 15 SIGN 2

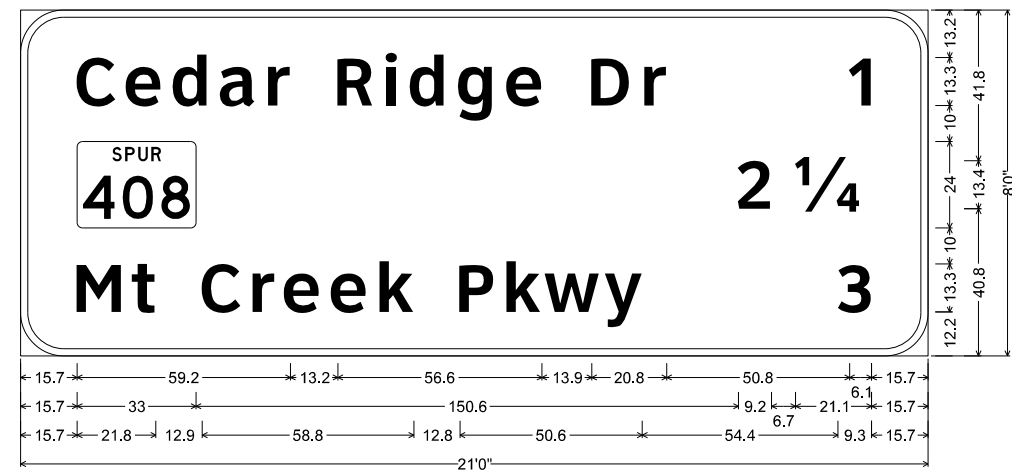

12.0" Radius, 2.0" Border, White on Green;
 "Cedar Ridge Dr", ClearviewHwy-5-W-R; "1", ClearviewHwy-5-W-R; State Highway 408 M1-6S3;
 "2 1/4", ClearviewHwy-5-W-R; "Mt Creek Pkwy", ClearviewHwy-5-W-R; "3", ClearviewHwy-5-W-R;

SHEET 15 SIGN 4

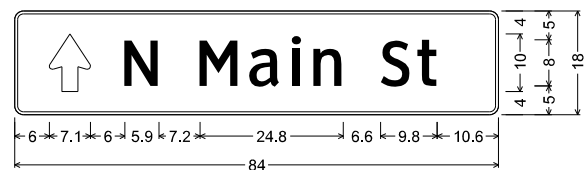

D1-1 8in UP;
 1.5" Radius, 0.5" Border, White on Green;
 Standard Arrow Custom 10.0" X 7.1" 90";
 "N Main St", ClearviewHwy-3-W;

SHEET 15 SIGN 6

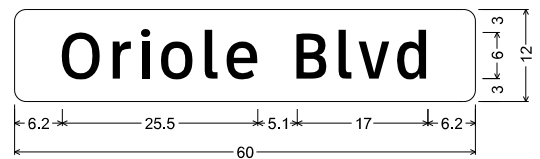

D3-1G(1) 6in;
 1.5" Radius, No border, White on Green;
 "Oriole Blvd", ClearviewHwy-3-W;

SHEET 16 SIGN 1
 SHEET 16 SIGN 2

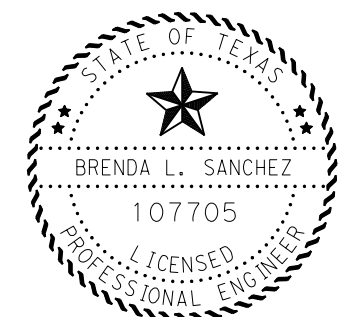

Brenda L Sanchez, P.E. 03/20/23
 Signature of Registrar & Date



GUIDE SIGN DETAILS

SCALE: NTS SHEET 9 OF 47

DESIGN/CK	FED. RD. DIV. NO.	STATE PROJECT NO.		HIGHWAY NO.
BLS	6	(SEE TITLE SHEET)		IH 20
CHECK	STATE	DISTRICT	COUNTY	SHEET NO.
BLS	TEXAS	DAL	VARIOUS	234
CHECK	CONTROL	SECTION	JOB	
MA	0095	14	033, ETC	
CHECK	BA			

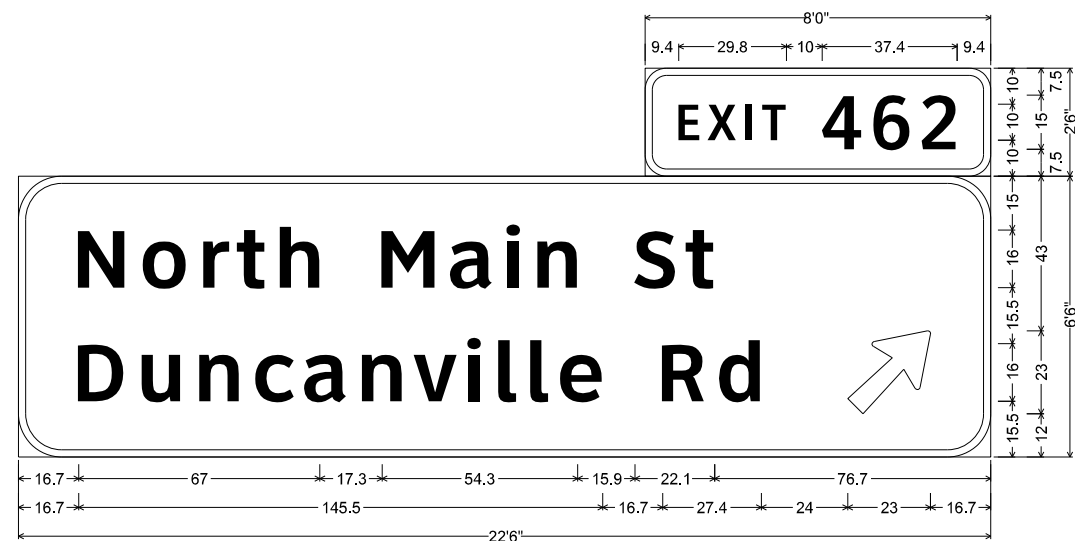

6.0" Radius, 2.0" Border, White on Green;
 "EXIT 462", ClearviewHwy-4-W;
 12.0" Radius, 2.0" Border, White on Green;
 "North Main St", ClearviewHwy-5-W-R; "Duncanville Rd", ClearviewHwy-5-W-R; Arrow A-2 - 29.3" 45°;

SHEET 16 SIGN 3

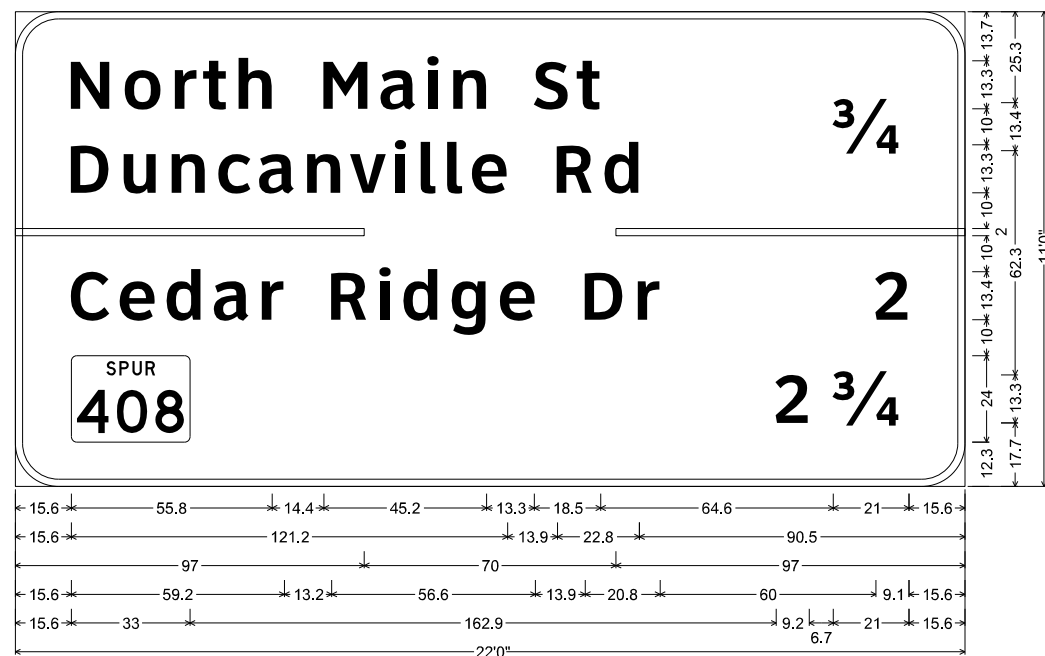

12.0" Radius, 2.0" Border, White on Green;
 "North Main St", ClearviewHwy-5-W-R; "Duncanville Rd", ClearviewHwy-5-W-R; "3/4", ClearviewHwy-5-W-R;
 "Cedar Ridge Dr", ClearviewHwy-5-W-R; "2", ClearviewHwy-5-W-R; State Highway 408 M1-6S3;
 "2 3/4", ClearviewHwy-5-W-R;

SHEET 17 SIGN 2

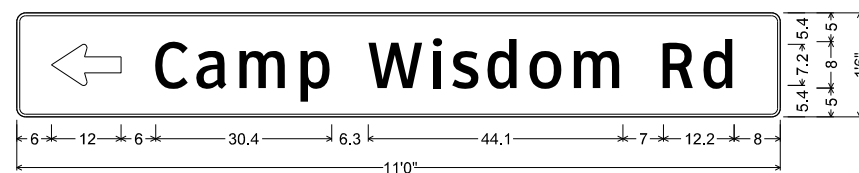

D1-1 8in LT;
 1.5" Radius, 0.5" Border, White on Green;
 Standard Arrow Custom 12.0" X 7.1" 180°; "Camp Wisdom Rd", ClearviewHwy-3-W;

SHEET 17 SIGN 3

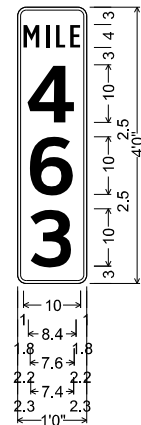

D10-3 10in;
 1.5" Radius, 0.5" Border, White on Green;
 "MILE", ClearviewHwy-2-W;
 "4", ClearviewHwy-6-W;
 "6", ClearviewHwy-6-W;
 "3", ClearviewHwy-6-W;

SHEET 16 SIGN 4

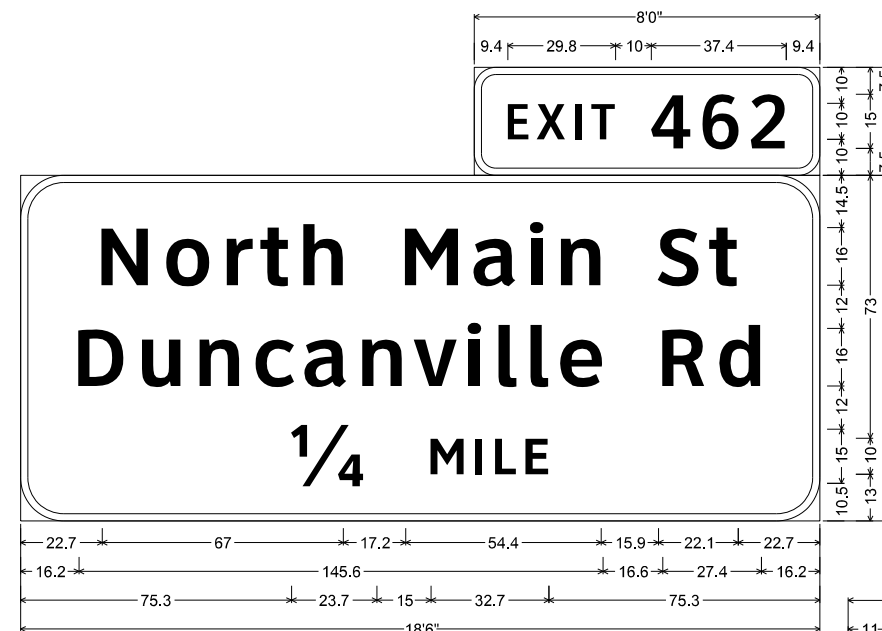

6.0" Radius, 2.0" Border, White on Green;
 "EXIT 462", ClearviewHwy-4-W;
 12.0" Radius, 2.0" Border, White on Green;
 "North Main St", ClearviewHwy-5-W-R; "Duncanville Rd", ClearviewHwy-5-W-R;
 "1/4", ClearviewHwy-5-W-R; "MILE", ClearviewHwy-5-W-R;

SHEET 16 SIGN 5

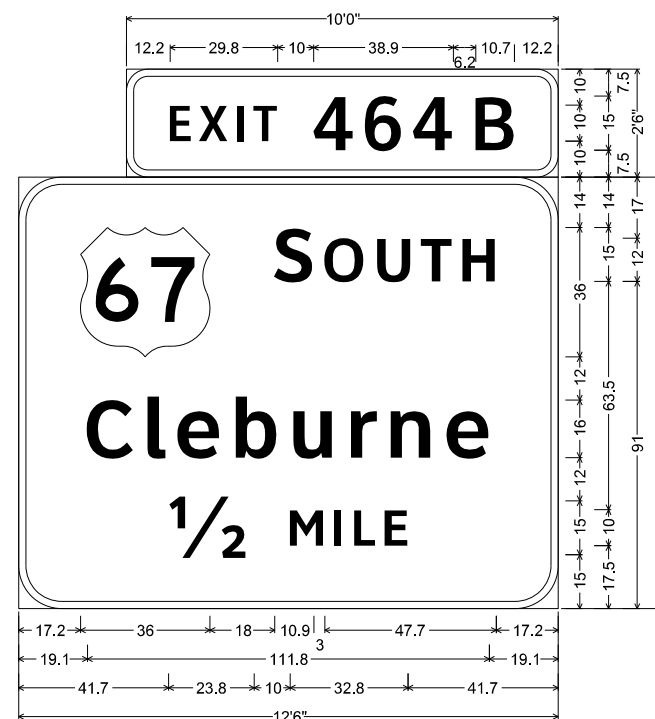

6.0" Radius, 2.0" Border, White on Green;
 "EXIT", ClearviewHwy-4-W; "464 B", ClearviewHwy-4-W;
 12.0" Radius, 2.0" Border, White on Green;
 US 67 M1-4; "S OUTH", ClearviewHwy-5-W-R;
 "Cleburne", ClearviewHwy-5-W-R; "1/2", ClearviewHwy-5-W-R;
 "MILE", ClearviewHwy-5-W-R;

SHEET 17 SIGN 4



6.0" Radius, 2.0" Border, White on Green;
 "EXIT", ClearviewHwy-4-W; "464 A", ClearviewHwy-4-W;
 12.0" Radius, 2.0" Border, White on Green;
 US 67 M1-4; "N ORTH", ClearviewHwy-5-W-R;
 "Dallas", ClearviewHwy-5-W-R; "1/4", ClearviewHwy-5-W-R;
 "MILE", ClearviewHwy-5-W-R;

SHEET 17 SIGN 5
SHEET 19 SIGN 5

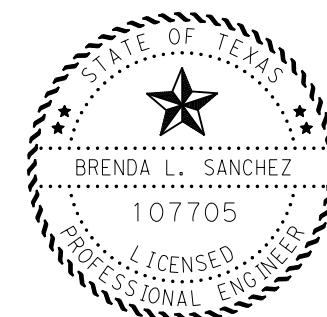

Brenda L Sanchez, P.E. 03/20/23
 Signature of Registrant & Date

 Texas Department of Transportation © 2023				
GUIDE SIGN DETAILS				
SCALE: NTS			SHEET 10 OF 47	
DESIGN/CK BLS	FED. RD. DIV. NO. 6	STATE PROJECT NO. (SEE TITLE SHEET)		HIGHWAY NO. IH 20
CHECK BLS	STATE	DISTRICT	COUNTY	SHEET NO.
CHECK MA	TEXAS	DAL	VARIOUS	235
CHECK BA	CONTROL	SECTION	JOB	
	0095	14	033, ETC	

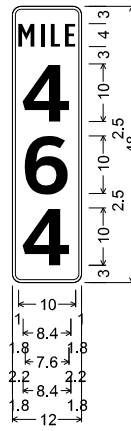

D10-3 10in;
 1.5" Radius, 0.5" Border, White on Green;
 "MILE", ClearviewHwy-2-W;
 "4", ClearviewHwy-6-W;
 "6", ClearviewHwy-6-W;
 "4", ClearviewHwy-6-W;

SHEET 18 OF 1
 SHEET 18 OF 2

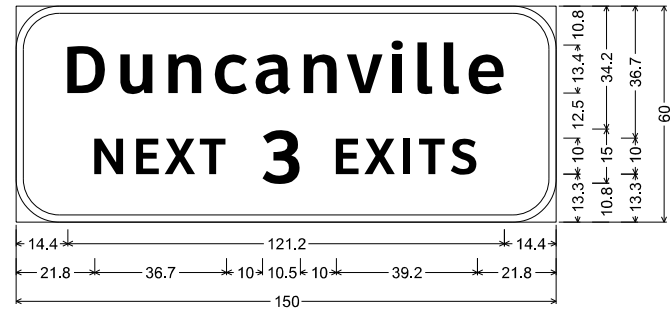

12.0" Radius, 2.0" Border, White on Green;
 "Duncanville", ClearviewHwy-5-W-R; "NEXT", ClearviewHwy-5-W-R;
 "3", ClearviewHwy-5-W-R; "EXITS", ClearviewHwy-5-W-R;

SHEET 18 SIGN 3

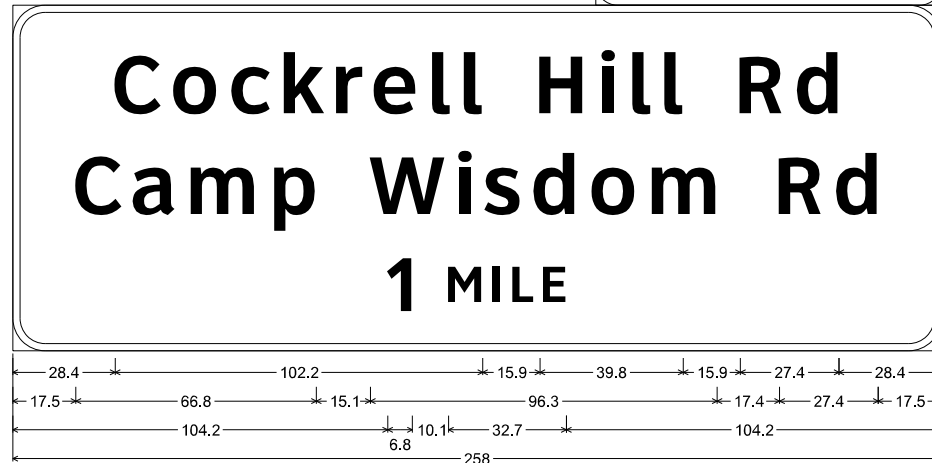
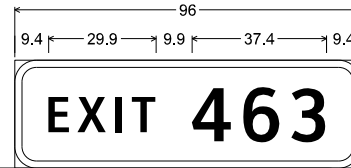

6.0" Radius, 2.0" Border, White on Green;
 "EXIT 463", ClearviewHwy-4-W;
 9.0" Radius, 2.0" Border, White on Green;
 "Cockrell Hill Rd", ClearviewHwy-5-W-R; "Camp Wisdom Rd", ClearviewHwy-5-W-R; "1 MILE", ClearviewHwy-5-W-R;

SHEET 19 SIGN 2

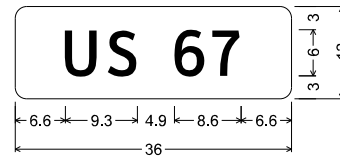

D3-1G(1) 6in;
 1.5" Radius, No border, White on Green;
 "US 67", ClearviewHwy-3-W;

SHEET 18 SIGN 4
 SHEET 18 SIGN 9

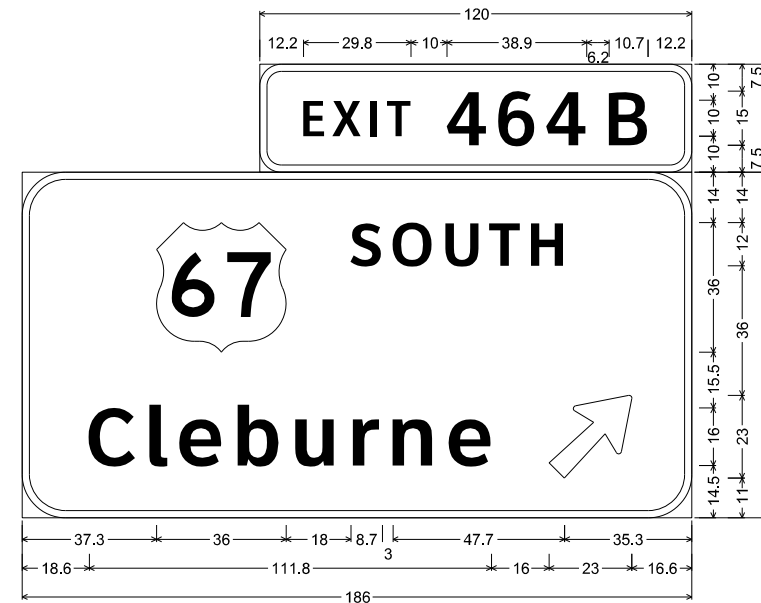

6.0" Radius, 2.0" Border, White on Green;
 "EXIT", ClearviewHwy-4-W; "464 B", ClearviewHwy-4-W;
 12.0" Radius, 2.0" Border, White on Green;
 US 67 M1-4; "S OUTH", ClearviewHwy-5-W-R; "Cleburne", ClearviewHwy-5-W-R;
 Arrow A-2 - 29.3" 45";

SHEET 18 SIGN 6
 SHEET 19 SIGN 6

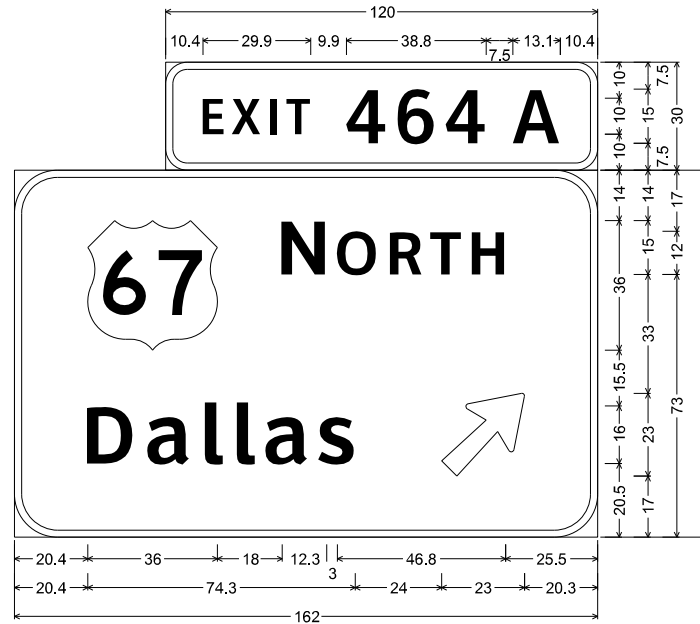

6.0" Radius, 2.0" Border, White on Green;
 "EXIT 464 A", ClearviewHwy-4-W;
 12.0" Radius, 2.0" Border, White on Green;
 US 67 M1-4; "N ORTH", ClearviewHwy-5-W-R;
 "Dallas", ClearviewHwy-5-W-R; Arrow A-2 - 29.3" 45";

SHEET 19 SIGN 3

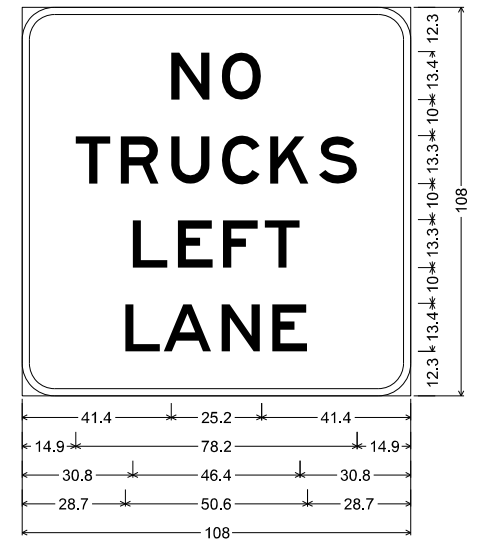

9.0" Radius, 2.0" Border, Black on White;
 "NO", E; "TRUCKS", E; "LEFT", E;
 "LANE", E;

SHEET 18 SIGN 8
 SHEET 21 SIGN 2
 SHEET 23 SIGN 8

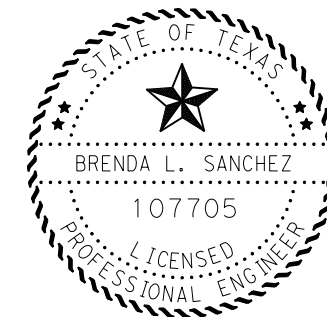

Brenda L Sanchez, P.E. 03/20/23
 Signature of Registrar & Date



GUIDE SIGN DETAILS

SCALE: NTS SHEET 11 OF 47

DESIGN/CK	FED. RD. DIV. NO.	STATE PROJECT NO.		HIGHWAY NO.
BLS	6	(SEE TITLE SHEET)		IH 20
CHECK	STATE	DISTRICT	COUNTY	SHEET NO.
BLS	TEXAS	DAL	VARIOUS	236
CHECK	CONTROL	SECTION	JOB	
MA	0095	14	033, ETC	

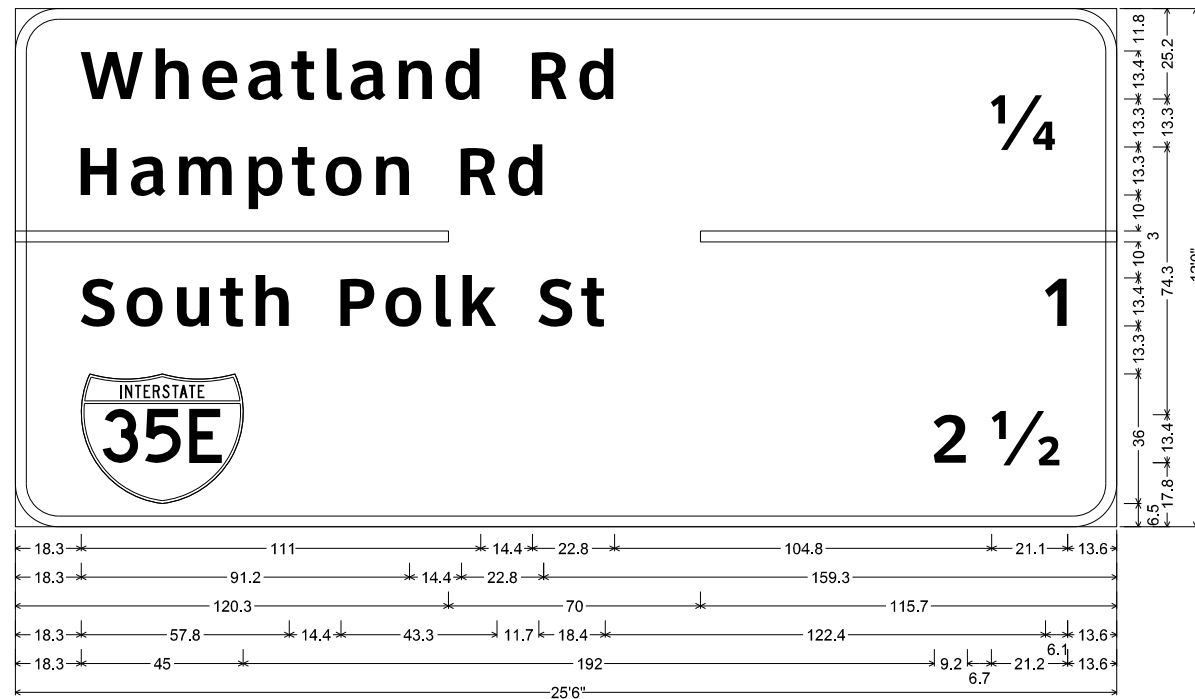

12.0" Radius, 3.0" Border, White on Green;
 "Wheatland Rd", ClearviewHwy-5-W-R; "Hampton Rd", ClearviewHwy-5-W-R; "1/4", ClearviewHwy-5-W-R;
 "South Polk St", ClearviewHwy-5-W-R; "1", ClearviewHwy-5-W-R; Interstate 35E M1-1 15.0" D; "2 1/2", ClearviewHwy-5-W-R;

SHEET 19 SIGN 7

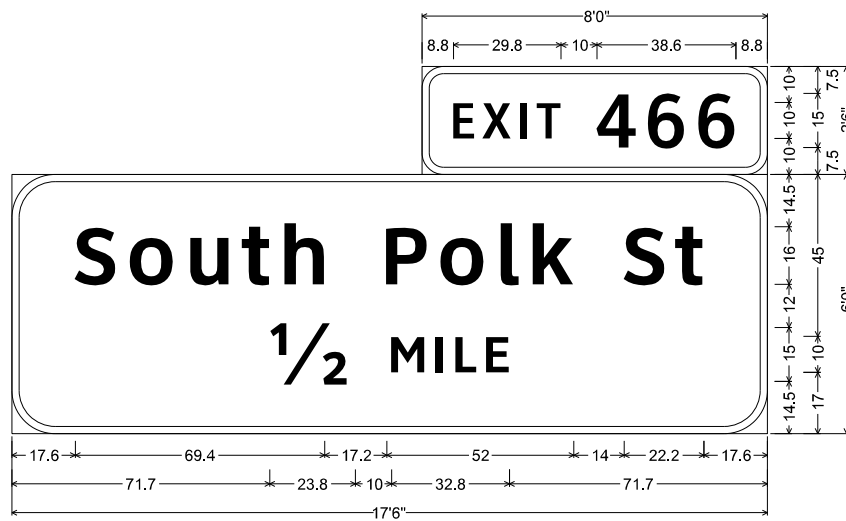

6.0" Radius, 2.0" Border, White on Green;
 "EXIT 466", ClearviewHwy-4-W;
 12.0" Radius, 2.0" Border, White on Green;
 "South Polk St", ClearviewHwy-5-W-R; "1/2 MILE", ClearviewHwy-5-W-R;

SHEET 20 SIGN 2

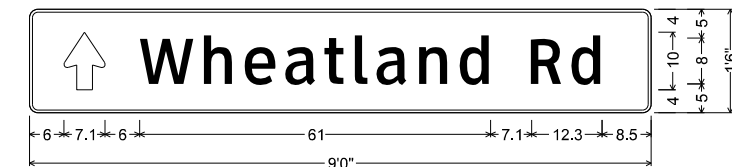

D1-1 8in UP;
 1.5" Radius, 0.5" Border, White on Green;
 Standard Arrow Custom 10.0" X 7.1" 90"; "Wheatland Rd", ClearviewHwy-3-W;

SHEET 21 SIGN 1

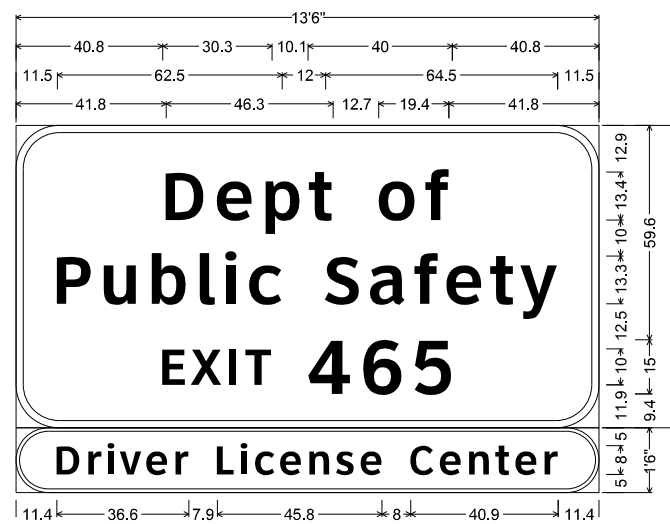

12.0" Radius, 2.0" Border, White on Green;
 "Dept of", ClearviewHwy-5-W-R; "Public Safety", ClearviewHwy-5-W-R;
 "EXIT 465", ClearviewHwy-5-W-R;
 9.0" Radius, 1.0" Border, White on Green;
 "Driver License Center", ClearviewHwy-5-W-R;

SHEET 19 SIGN 8

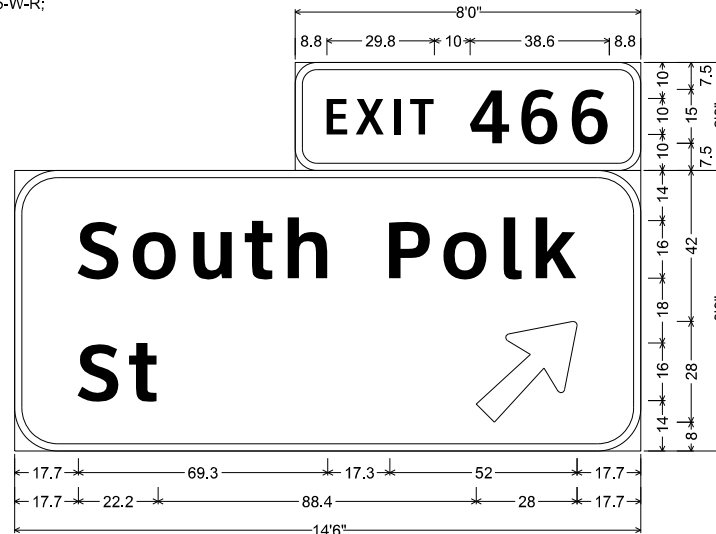

6.0" Radius, 2.0" Border, White on Green;
 "EXIT 466", ClearviewHwy-4-W;
 12.0" Radius, 2.0" Border, White on Green;
 "South Polk", ClearviewHwy-5-W-R; "St", ClearviewHwy-5-W-R;
 Arrow A-3 - 35.6" 45°;

SHEET 21 SIGN 4
SHEET 24 SIGN 1

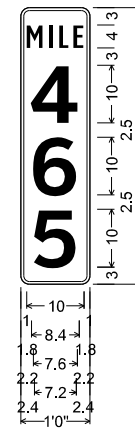

D10-3 10in;
 1.5" Radius, 0.5" Border, White on Green;
 "MILE", ClearviewHwy-2-W;
 "4", ClearviewHwy-6-W;
 "6", ClearviewHwy-6-W;
 "5", ClearviewHwy-6-W;

SHEET 20 SIGN 1

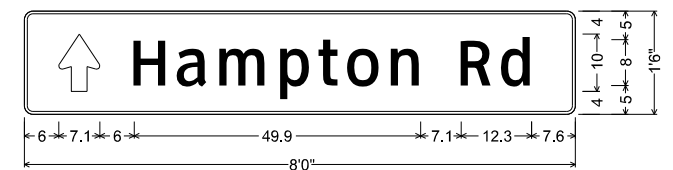

D1-1 8in UP;
 1.5" Radius, 0.5" Border, White on Green;
 Standard Arrow Custom 10.0" X 7.1" 90°;
 "Hampton Rd", ClearviewHwy-3-W;

SHEET 20 SIGN 3

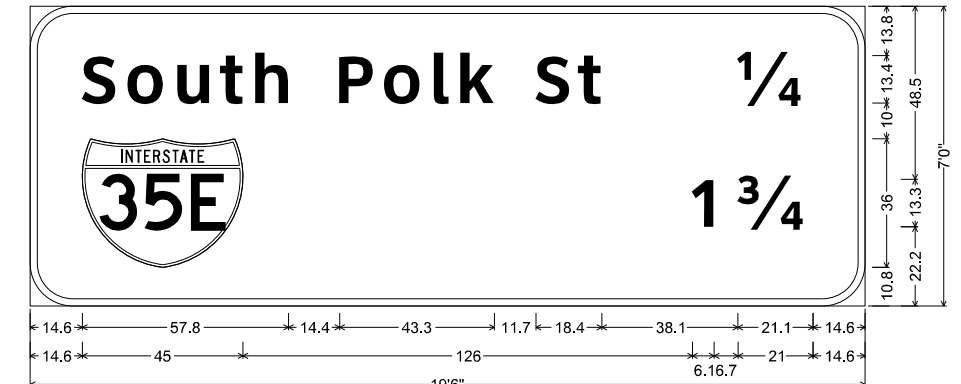

12.0" Radius, 2.0" Border, White on Green;
 "South Polk St", ClearviewHwy-5-W-R; "1/4", ClearviewHwy-5-W-R; Interstate 35E M1-1 16.0" D;
 "1 3/4", ClearviewHwy-5-W-R;

SHEET 21 SIGN 3

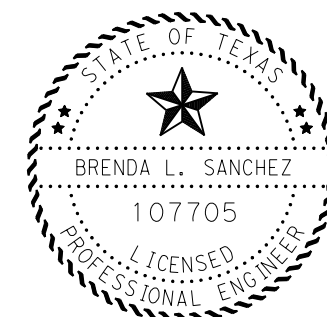

Brenda L Sanchez, P.E. 03/20/23
 Signature of Registrant & Date



GUIDE SIGN DETAILS

SCALE: NTS SHEET 12 OF 47

DESIGN/CK	FED. RD. DIV. NO.	STATE PROJECT NO.		HIGHWAY NO.
BLS	6	(SEE TITLE SHEET)		IH 20
CHECK	STATE	DISTRICT	COUNTY	SHEET NO.
BLS	TEXAS	DAL	VARIOUS	237
CHECK	CONTROL	SECTION	JOB	
MA	0095	14	033, ETC	

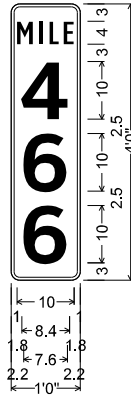

D10-3 10in;
 1.5" Radius, 0.5" Border, White on Green;
 "MILE", ClearviewHwy-2-W;
 "4", ClearviewHwy-6-W;
 "6", ClearviewHwy-6-W;
 "6", ClearviewHwy-6-W;

SHEET 22 SIGN 2
 SHEET 22 SIGN 3

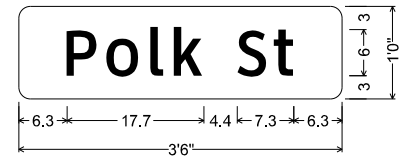

D3-1G(1) 6in;
 1.5" Radius, No border, White on Green;
 "Polk St", ClearviewHwy-3-W;

SHEET 23 OF 1
 SHEET 23 OF 3

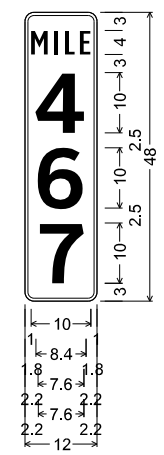

D10-3 10in;
 1.5" Radius, 0.5" Border, White on Green;
 "MILE", ClearviewHwy-2-W;
 "4", ClearviewHwy-6-W;
 "6", ClearviewHwy-6-W;
 "7", ClearviewHwy-6-W;

SHEET 23 SIGN 5
 SHEET 23 SIGN 6

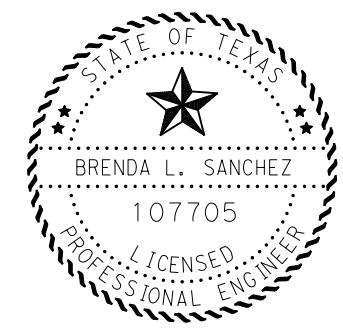

Brenda L Sanchez, P.E. 03/20/23
 Signature of Registrant & Date

Texas Department of Transportation © 2023				
<h3>GUIDE SIGN DETAILS</h3>				
SCALE: NTS			SHEET 13 OF 47	
DESIGN/CK	FED. RD. DIV. NO.	STATE PROJECT NO.		HIGHWAY NO.
BLS	6	(SEE TITLE SHEET)		IH 20
CHECK	STATE	DISTRICT	COUNTY	SHEET NO.
BLS	TEXAS	DAL	VARIOUS	238
CHECK	CONTROL	SECTION	JOB	
MA	0095	14	033, ETC	
CHECK	BA			

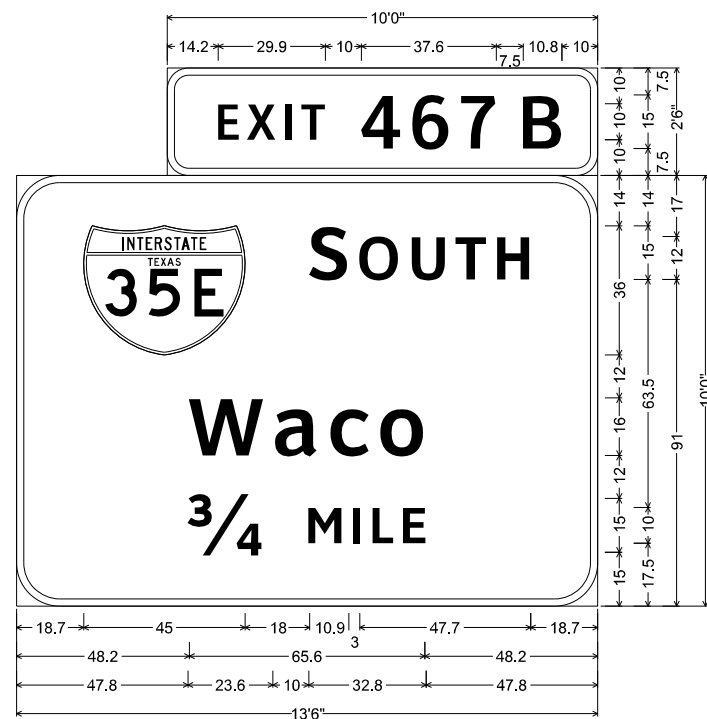

6.0" Radius, 2.0" Border, White on Green;
 "EXIT", ClearviewHwy-4-W; "467", ClearviewHwy-4-W;
 "B", ClearviewHwy-4-W;

12.0" Radius, 2.0" Border, White on Green;
 State Name 35E M1-1T 13.3" D; "S OUTH", ClearviewHwy-5-W-R;
 "Waco", ClearviewHwy-5-W-R; "3/4", ClearviewHwy-5-W-R;
 "MILE", ClearviewHwy-5-W-R;

SHEET 23 SIGN 7



6.0" Radius, 2.0" Border, White on Green;
 "EXIT", ClearviewHwy-4-W; "467", ClearviewHwy-4-W;
 "A", ClearviewHwy-4-W;

12.0" Radius, 2.0" Border, White on Green;
 State Name 35E M1-1T 13.3" D; "N ORTH", ClearviewHwy-5-W-R;
 "Dallas", ClearviewHwy-5-W-R; "1/2", ClearviewHwy-5-W-R;
 "MILE", ClearviewHwy-5-W-R;

SHEET 23 SIGN 8

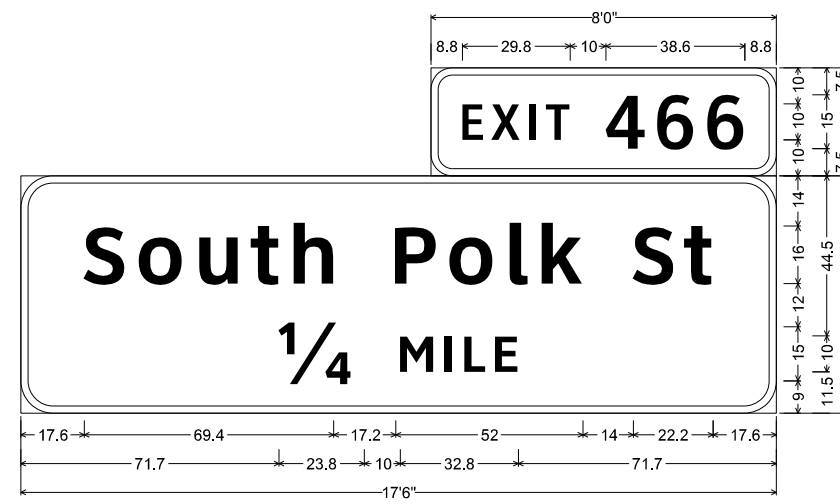

6.0" Radius, 2.0" Border, White on Green;
 "EXIT 466", ClearviewHwy-4-W;

9.0" Radius, 2.0" Border, White on Green;
 "South Polk St", ClearviewHwy-5-W-R; "1/4 MILE", ClearviewHwy-5-W-R;

SHEET 24 SIGN 2

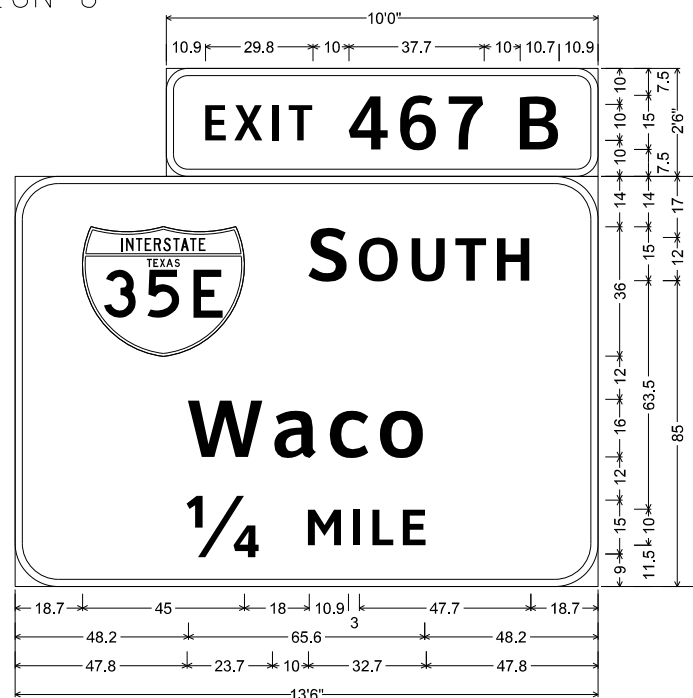

6.0" Radius, 2.0" Border, White on Green;
 "EXIT", ClearviewHwy-4-W; "467", ClearviewHwy-4-W;
 "B", ClearviewHwy-4-W;

12.0" Radius, 2.0" Border, White on Green;
 State Name 35E M1-1T 13.3" D; "S OUTH", ClearviewHwy-5-W-R;
 "Waco", ClearviewHwy-5-W-R; "1/4", ClearviewHwy-5-W-R;
 "MILE", ClearviewHwy-5-W-R;

SHEET 24 SIGN 3

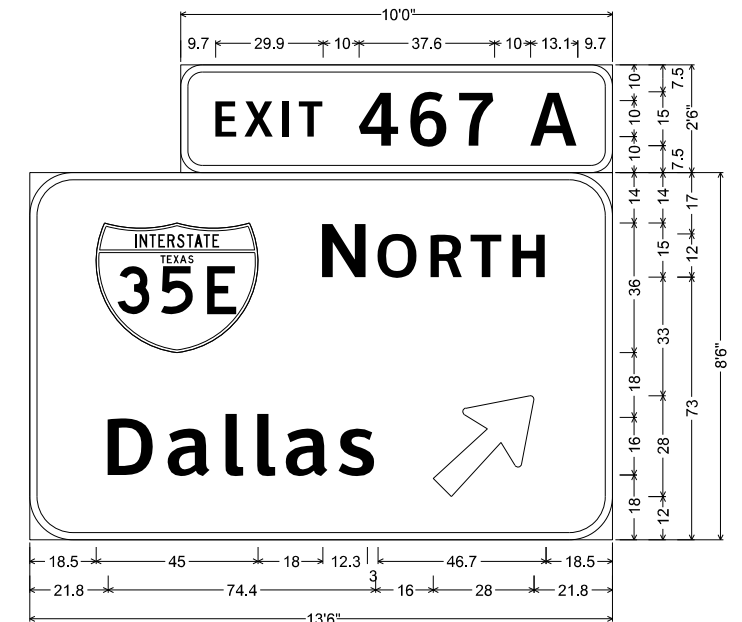

6.0" Radius, 2.0" Border, White on Green;
 "EXIT", ClearviewHwy-4-W; "467", ClearviewHwy-4-W;
 "A", ClearviewHwy-4-W;

12.0" Radius, 2.0" Border, White on Green;
 State Name 35E M1-1T 13.3" D; "N ORTH", ClearviewHwy-5-W-R;
 "Dallas", ClearviewHwy-5-W-R; Arrow A-3 - 35.6" 45";

SHEET 24 SIGN 4
SHEET 25 SIGN 3

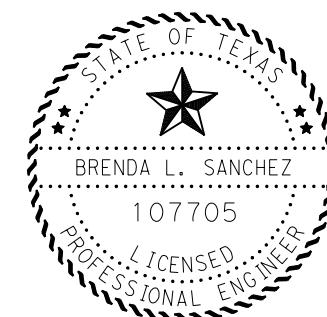

Brenda L Sanchez, P.E. 03/20/23
 Signature of Registrant & Date



GUIDE SIGN DETAILS

SCALE: NTS SHEET 14 OF 47

DESIGN/CK	FED. RD. DIV. NO.	STATE PROJECT NO.		HIGHWAY NO.
BLS	6	(SEE TITLE SHEET)		IH 20
CHECK	STATE	DISTRICT	COUNTY	SHEET NO.
BLS	TEXAS	DAL	VARIOUS	239
CHECK	CONTROL	SECTION	JOB	
MA	0095	14	033, ETC	

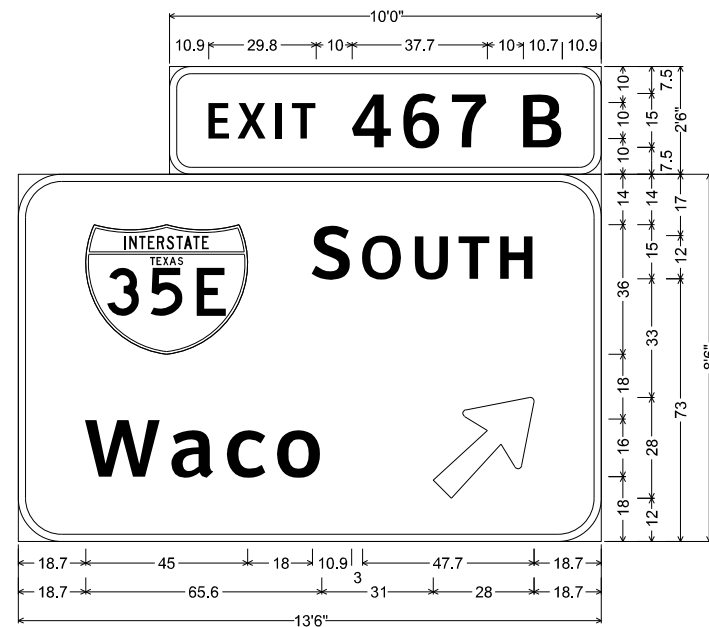

6.0" Radius, 2.0" Border, White on Green;
 "EXIT", ClearviewHwy-4-W; "467", ClearviewHwy-4-W;
 "B", ClearviewHwy-4-W;
 12.0" Radius, 2.0" Border, White on Green;
 State Name 35E M1-1T 13.3" D; "S OUTH", ClearviewHwy-5-W-R;
 "Waco", ClearviewHwy-5-W-R; Arrow A-3 - 35.6" 45";

SHEET 24 SIGN 6
 SHEET 26 SIGN 2



6.0" Radius, 2.0" Border, White on Green;
 "EXIT", ClearviewHwy-4-W; "467", ClearviewHwy-4-W;
 "A", ClearviewHwy-4-W;
 12.0" Radius, 2.0" Border, White on Green;
 Interstate 35E M1-1 16.0" C; "N ORTH", ClearviewHwy-5-W-R;
 "Dallas", ClearviewHwy-5-W-R; "1/4", ClearviewHwy-5-W-R;
 "MILE", ClearviewHwy-5-W-R;

SHEET 26 SIGN 1

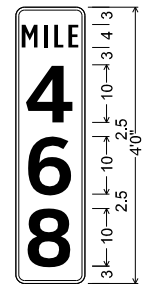

D10-3 10in;
 1.5" Radius, 0.5" Border, White on Green;
 "MILE", ClearviewHwy-2-W;
 "4", ClearviewHwy-6-W;
 "6", ClearviewHwy-6-W;
 "8", ClearviewHwy-6-W;

SHEET 25 SIGN 5
 SHEET 25 SIGN 6

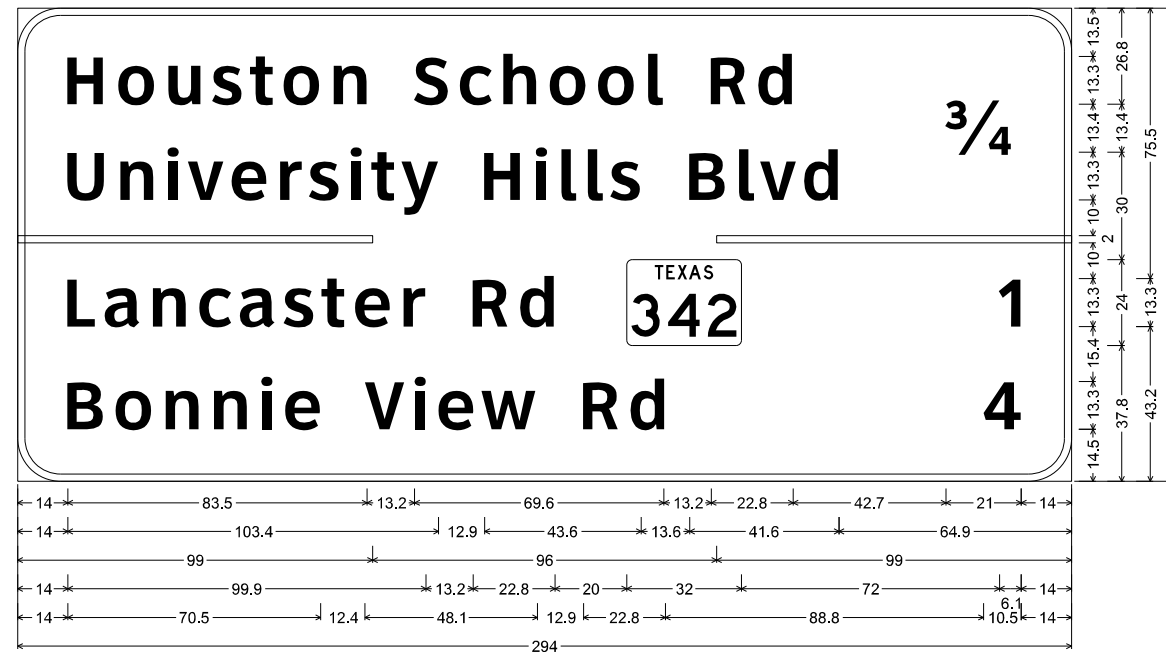

12.0" Radius, 2.0" Border, White on Green;
 "Houston School Rd", ClearviewHwy-5-W-R; "University Hills Blvd", ClearviewHwy-5-W-R; "3/4", ClearviewHwy-5-W-R;
 "Lancaster Rd", ClearviewHwy-5-W-R; State Highway 342 M1-6T3; "1", ClearviewHwy-5-W-R; "Bonnie View Rd", ClearviewHwy-5-W-R;
 "4", ClearviewHwy-5-W-R;

SHEET 25 SIGN 8

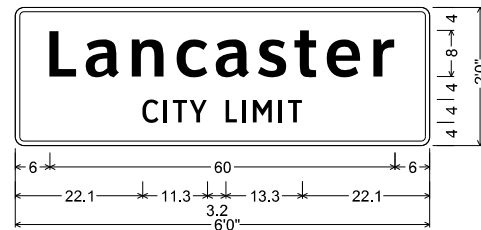

I-2aT 8in;
 1.5" Radius, 0.8" Border, White on Green;
 "Lancaster", ClearviewHwy-5-W-R;
 "CITY LIMIT", ClearviewHwy-3-W;

SHEET 26 SIGN 5
 SHEET 29 SIGN 2

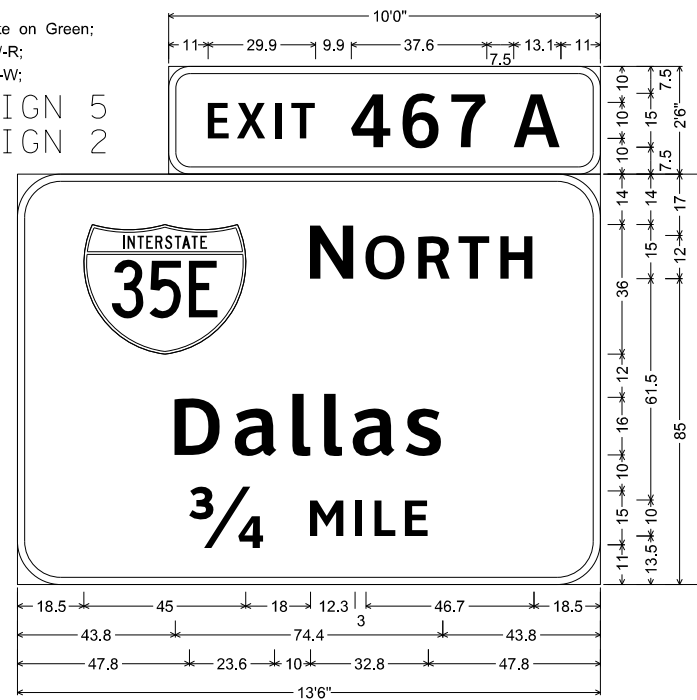

6.0" Radius, 2.0" Border, White on Green;
 "EXIT 467 A", ClearviewHwy-4-W;
 12.0" Radius, 2.0" Border, White on Green;
 Interstate 35E M1-1 16.0" C; "N ORTH", ClearviewHwy-5-W-R;
 "Dallas", ClearviewHwy-5-W-R; "3/4", ClearviewHwy-5-W-R;
 "MILE", ClearviewHwy-5-W-R;

SHEET 27 SIGN 1

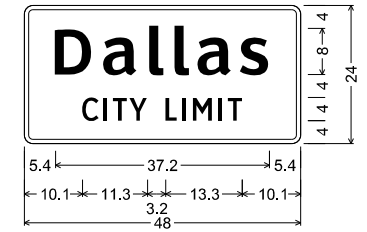

I-2aT 8in;
 1.5" Radius, 0.8" Border, White on Green;
 "Dallas", ClearviewHwy-5-W-R;
 "CITY LIMIT", ClearviewHwy-3-W;

SHEET 26 SIGN 3
 SHEET 29 SIGN 6
 SHEET 37 SIGN 1
 SHEET 40 SIGN 3
 SHEET 47 SIGN 3



9.0" Radius, 1.5" Border, White on Green;
 "UNT Dallas", ClearviewHwy-5-W-R;
 "EXIT 468", ClearviewHwy-5-W-R;

SHEET 26 SIGN 4
 SHEET 29 SIGN 3

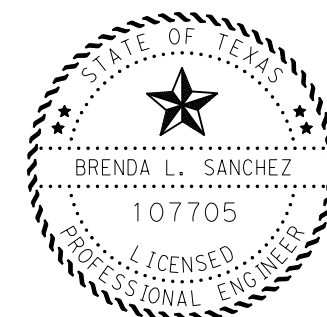

Brenda L Sanchez, P.E. 03/20/23
 Signature of Registrar & Date

			
GUIDE SIGN DETAILS			
SCALE: NTS		SHEET 15 OF 47	
DESIGN/CK BLS	FED. RD. DIV. NO. 6	STATE PROJECT NO. (SEE TITLE SHEET)	
CHECK BLS	STATE	DISTRICT DAL	HIGHWAY NO. IH 20
CHECK MA	TEXAS	COUNTY VARIOUS	SHEET NO. 240
CHECK BA	CONTROL 0095	SECTION 14	JOB 033, ETC

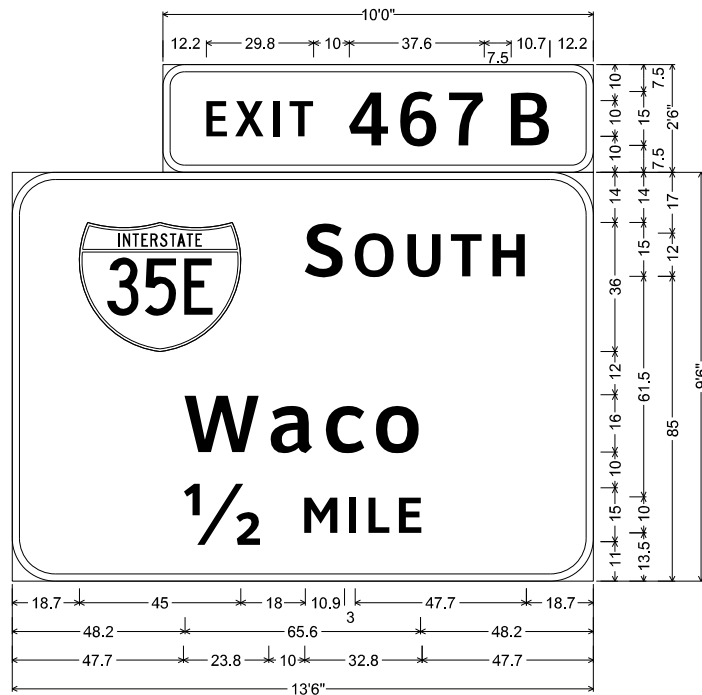

6.0" Radius, 2.0" Border, White on Green;
 "EXIT 467 B", ClearviewHwy-4-W;
 12.0" Radius, 2.0" Border, White on Green;
 Interstate 35E M1-1 16.0" C; "S OUTH", ClearviewHwy-5-W-R;
 "Waco", ClearviewHwy-5-W-R; "1/2", ClearviewHwy-5-W-R;
 "MILE", ClearviewHwy-5-W-R;

SHEET 27 SIGN 2



D1-2 8in LT-LT(MOD);
 1.9" Radius, 0.8" Border, White on Green;
 "University Hills", ClearviewHwy-3-W;
 1.9" Radius, 0.8" Border, White on Green;
 Standard Arrow Custom 12.0" X 7.1" 180°; "Blvd", ClearviewHwy-3-W;

SHEET 27 SIGN 9



D1-1 8in LT;
 1.5" Radius, 0.5" Border, White on Green;
 Standard Arrow Custom 12.0" X 7.1" 180°;
 "UNT Dallas", ClearviewHwy-3-W;

SHEET 27 SIGN 10

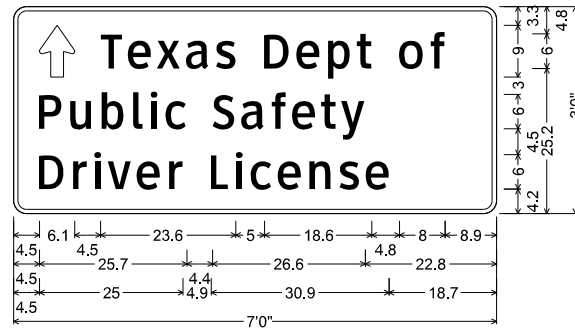

D26-2TL_84x36;
 2.3" Radius, 0.8" Border, White on Green;
 Standard Arrow Custom 9.0" X 6.1" 90°;
 "Texas Dept of", ClearviewHwy-3-W;
 "Public Safety", ClearviewHwy-3-W;
 "Driver License", ClearviewHwy-3-W;

SHEET 27 SIGN 3

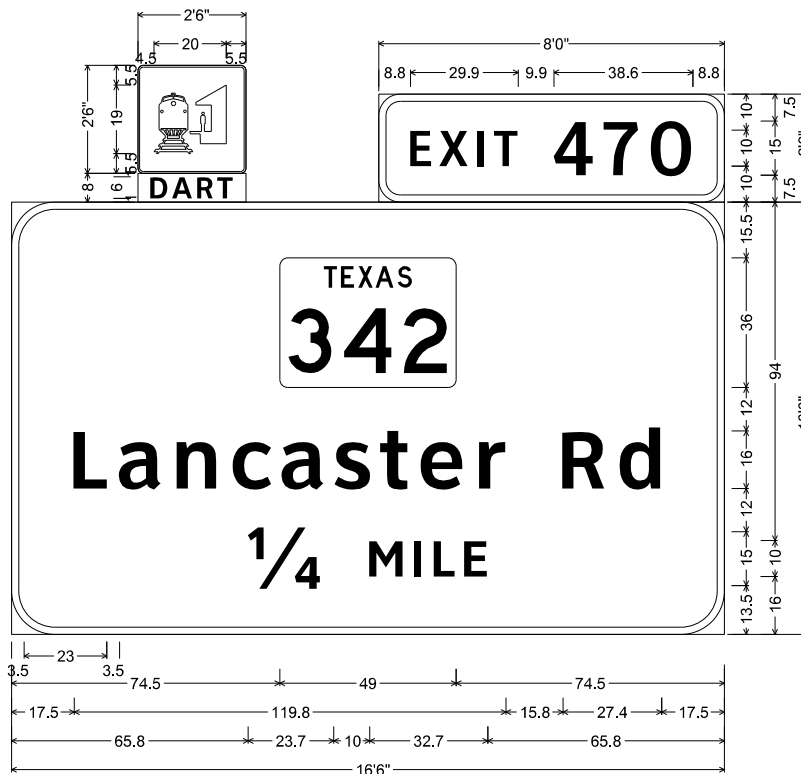

I-7_30x30;
 1.5" Radius, 0.5" Border, White on Green;
 Symbol I-7;
 No border, White on Green;
 "DART", ClearviewHwy-5-W-R;
 6.0" Radius, 2.0" Border, White on Green;
 "EXIT 470", ClearviewHwy-4-W;
 12.0" Radius, 2.0" Border, White on Green;
 State Highway 342 M1-6T3; "Lancaster Rd", ClearviewHwy-5-W-R;
 "1/4", ClearviewHwy-5-W-R; "MILE", ClearviewHwy-5-W-R;

SHEET 27 SIGN 11

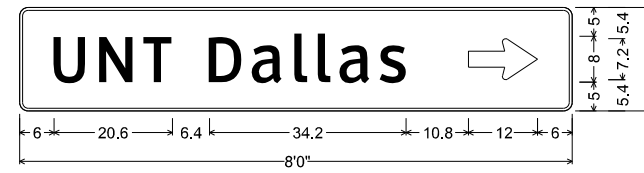

D1-1 8in RT;
 1.5" Radius, 0.5" Border, White on Green;
 "UNT Dallas", ClearviewHwy-3-W;
 Standard Arrow Custom 12.0" X 7.1" 0°;

SHEET 27 SIGN 4

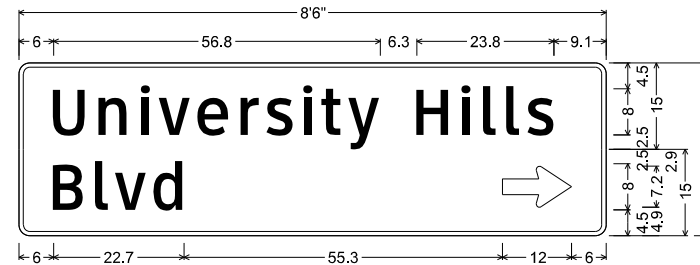

D1-2 8in RT-RT(MOD);
 1.9" Radius, 0.8" Border, White on Green;
 "University Hills", ClearviewHwy-3-W;
 1.9" Radius, 0.8" Border, White on Green;
 "Blvd", ClearviewHwy-3-W; Standard Arrow Custom 12.0" X 7.1" 0°;

SHEET 27 SIGN 5

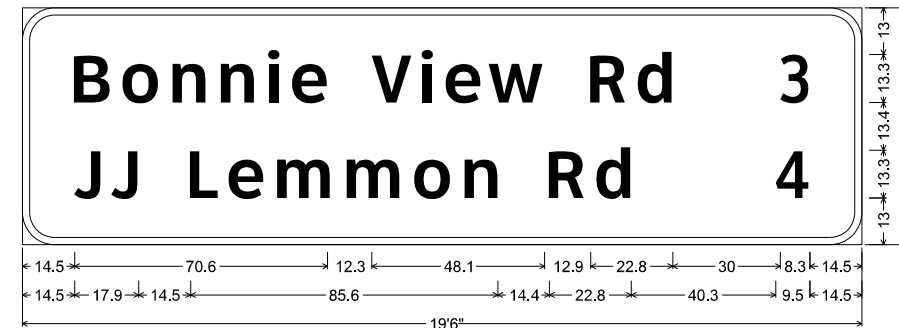

9.0" Radius, 2.0" Border, White on Green;
 "Bonnie View Rd", ClearviewHwy-5-W-R; "3", ClearviewHwy-3-W; "JJ Lemmon Rd", ClearviewHwy-5-W-R;
 "4", ClearviewHwy-3-W;

SHEET 27 SIGN 12

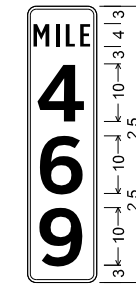

D10-3 10in;
 1.5" Radius, 0.5" Border, White on Green;
 "MILE", ClearviewHwy-2-W;
 "4", ClearviewHwy-6-W;
 "6", ClearviewHwy-6-W;
 "9", ClearviewHwy-6-W;

SHEET 27 SIGN 6
SHEET 27 SIGN 7

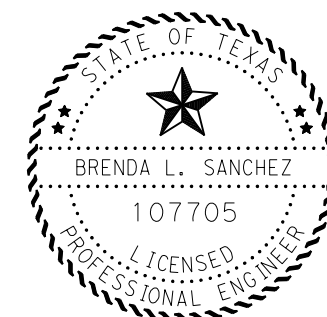

Brenda L Sanchez, P.E. 03/20/23
 Signature of Registrar & Date



GUIDE SIGN DETAILS

SCALE: NTS			SHEET 16 OF 47	
DESIGN/CK BLS	FED. RD. DIV. NO. 6	STATE PROJECT NO. (SEE TITLE SHEET)		HIGHWAY NO. IH 20
CHECK BLS	STATE	DISTRICT	COUNTY	SHEET NO.
CHECK MA	TEXAS	DAL	VARIOUS	241
CHECK BA	CONTROL	SECTION	JOB	
	0095	14	033, ETC	

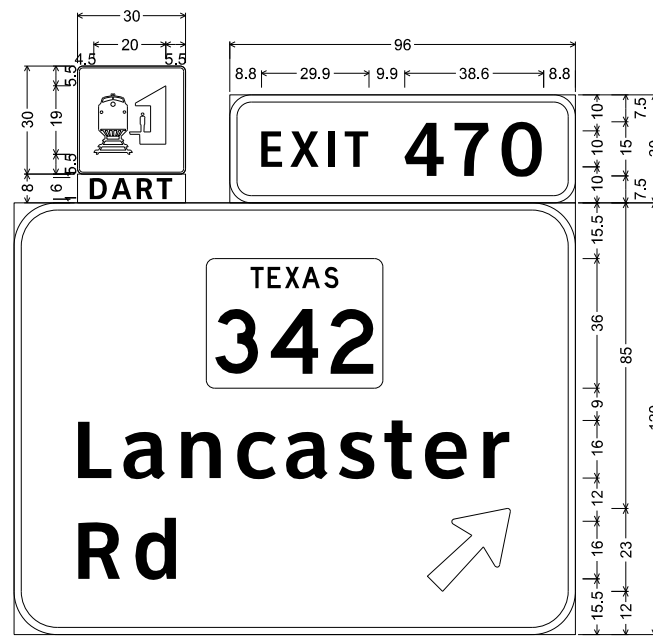

I-7_30x30;
1.5" Radius, 0.5" Border, White on Green;
Symbol I-7;

No border, White on Green;
"DART", ClearviewHwy-5-W-R;

6.0" Radius, 2.0" Border, White on Green;
"EXIT 470", ClearviewHwy-4-W;

12.0" Radius, 2.0" Border, White on Green;
State Highway 342 M1-6T3; "Lancaster", ClearviewHwy-5-W-R;
"Rd", ClearviewHwy-5-W-R; Arrow A-2 - 29.3" 45";

SHEET 27 SIGN 13
SHEET 30 SIGN 6



6.0" Radius, 2.0" Border, White on Green;
"EXITS", ClearviewHwy-6-W; "467 B-A", ClearviewHwy-4-W;

12.0" Radius, 2.0" Border, White on Green;
Interstate 35E M1-1 16.0" C; "Waco", ClearviewHwy-5-W-R;
"Dallas", ClearviewHwy-5-W-R; "1 1/4", ClearviewHwy-5-W-R;
"MILES", ClearviewHwy-5-W-R;

SHEET 28 SIGN 1



12.0" Radius, 2.0" Border, White on Green;
"Dept of", ClearviewHwy-5-W-R; "Public Safety", ClearviewHwy-5-W-R;
"EXIT 468", ClearviewHwy-5-W-R;

9.0" Radius, 1.0" Border, White on Green;
"Driver License Center", ClearviewHwy-5-W-R;

SHEET 30 SIGN 4

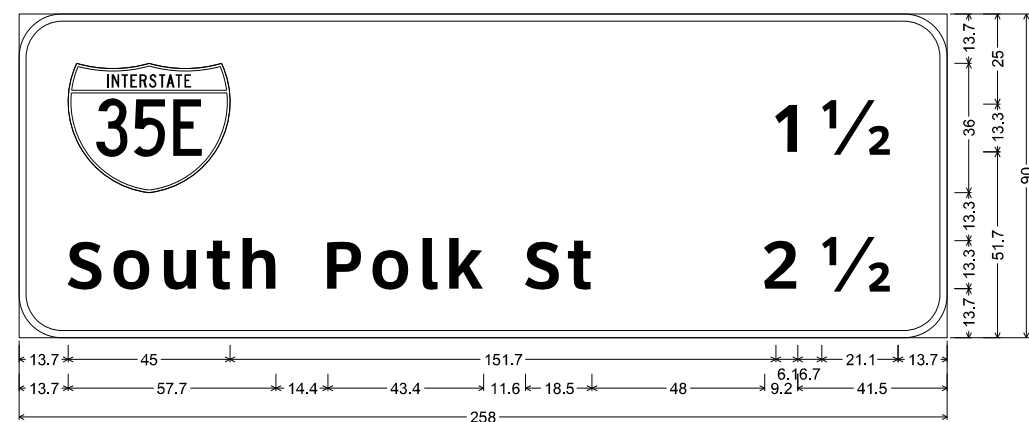

12.0" Radius, 2.0" Border, White on Green;
Interstate 35E M1-1 16.0" C; "1 1/2", ClearviewHwy-5-W-R; "South Polk St", ClearviewHwy-5-W-R;
"2 1/2", ClearviewHwy-5-W-R;

SHEET 29 SIGN 1

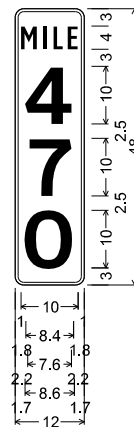

D10-3 10in;
1.5" Radius, 0.5" Border, White on Green;
"MILE", ClearviewHwy-2-W;
"4", ClearviewHwy-6-W;
"7", ClearviewHwy-6-W;
"0", ClearviewHwy-6-W;

SHEET 29 SIGN 4
SHEET 29 SIGN 5

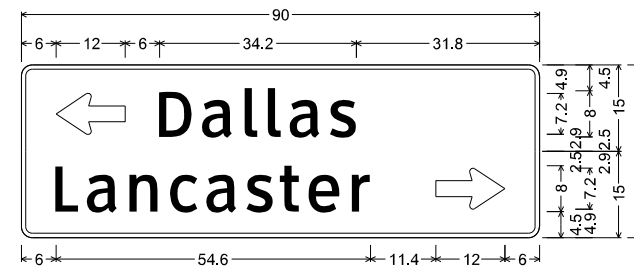

D1-2 8in LT-RT;
1.9" Radius, 0.8" Border, White on Green;
Standard Arrow Custom 12.0" X 7.1" 180°;
"Dallas", ClearviewHwy-3-W;
1.9" Radius, 0.8" Border, White on Green;
"Lancaster", ClearviewHwy-3-W;
Standard Arrow Custom 12.0" X 7.1" 0°;

SHEET 29 SIGN 7

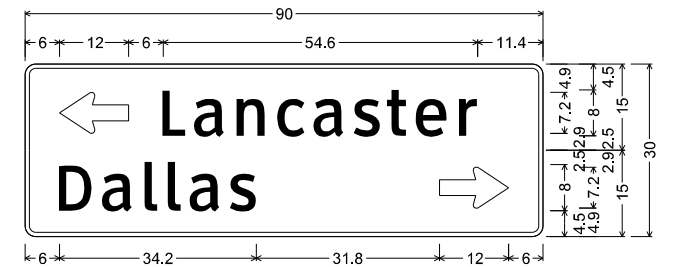

D1-2 8in LT-RT;
1.9" Radius, 0.8" Border, White on Green;
Standard Arrow Custom 12.0" X 7.1" 180°;
"Lancaster", ClearviewHwy-3-W;
"Dallas", ClearviewHwy-3-W;
Standard Arrow Custom 12.0" X 7.1" 0°;

SHEET 30 SIGN 2

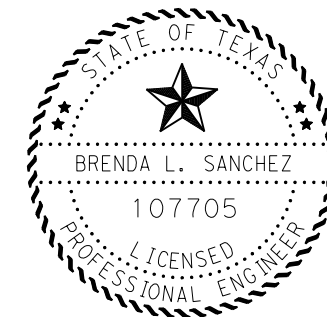

Brenda L Sanchez, P.E. 03/20/23
Signature of Registrant & Date

 © 2023			
GUIDE SIGN DETAILS			
SCALE: NTS		SHEET 17 OF 47	
DESIGN/CK BLS	FED. RD. DIV. NO. 6	STATE PROJECT NO. (SEE TITLE SHEET)	
CHECK BLS	STATE	DISTRICT DAL	HIGHWAY NO. IH 20
CHECK MA	TEXAS	COUNTY VARIOUS	SHEET NO.
CHECK BA	CONTROL 0095	SECTION 14	JOB 242
			033, ETC

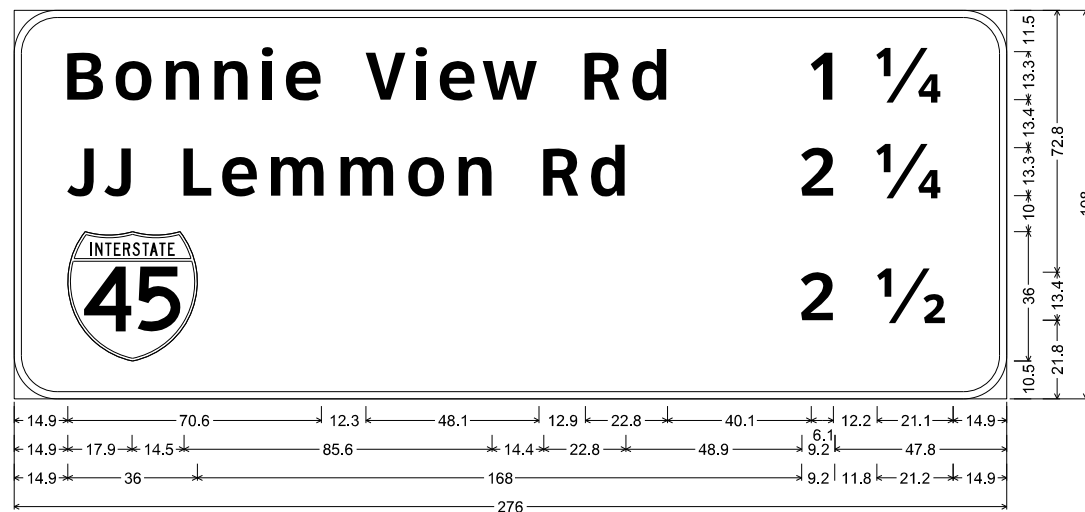

12.0" Radius, 2.0" Border, White on Green;
 "Bonnie View Rd", ClearviewHwy-5-W-R; "1 1/4", ClearviewHwy-5-W-R; "JJ Lemmon Rd", ClearviewHwy-5-W-R;
 "2 1/4", ClearviewHwy-5-W-R; Interstate 45 M1-1; "2 1/2", ClearviewHwy-5-W-R;

SHEET 30 SIGN 7

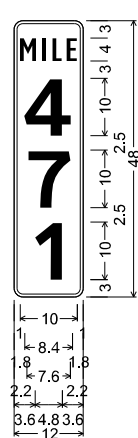

D10-3 10in;
 1.5" Radius, 0.5" Border, White on Green;
 "MILE", ClearviewHwy-2-W;
 "4", ClearviewHwy-6-W;
 "7", ClearviewHwy-6-W;
 "1", ClearviewHwy-6-W;

SHEET 31 SIGN 1
SHEET 31 SIGN 2

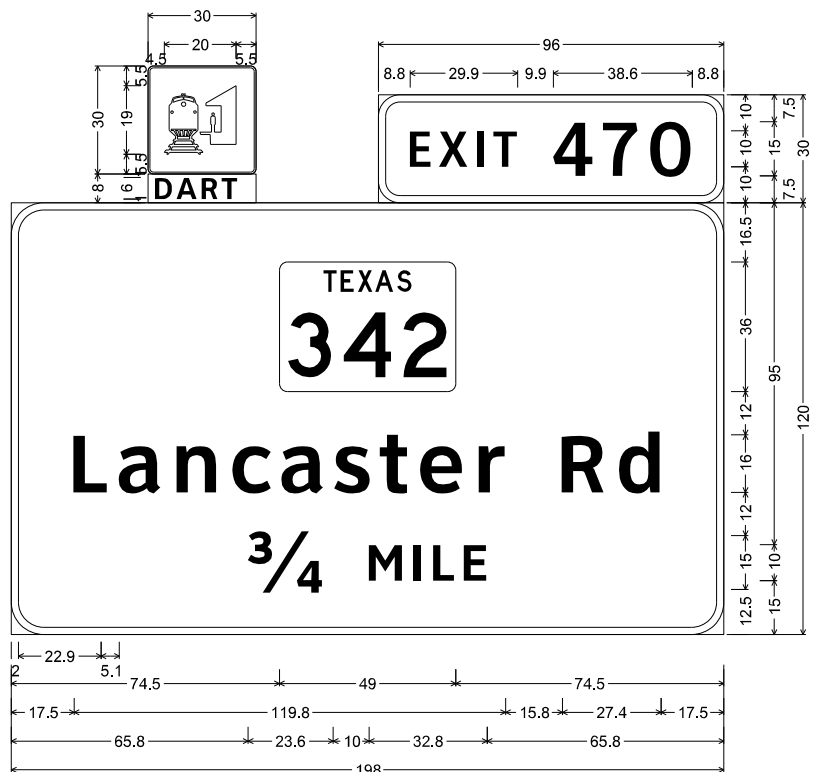

I-7_30x30;
 1.5" Radius, 0.5" Border, White on Green;
 Symbol I-7;
 No border, White on Green;
 "DART", ClearviewHwy-5-W-R;
 6.0" Radius, 2.0" Border, White on Green;
 "EXIT 470", ClearviewHwy-4-W;
 9.0" Radius, 2.0" Border, White on Green;
 State Highway 342 M1-6T3; "Lancaster Rd", ClearviewHwy-5-W-R;
 "3/4", ClearviewHwy-5-W-R; "MILE", ClearviewHwy-5-W-R;

SHEET 31 SIGN 4

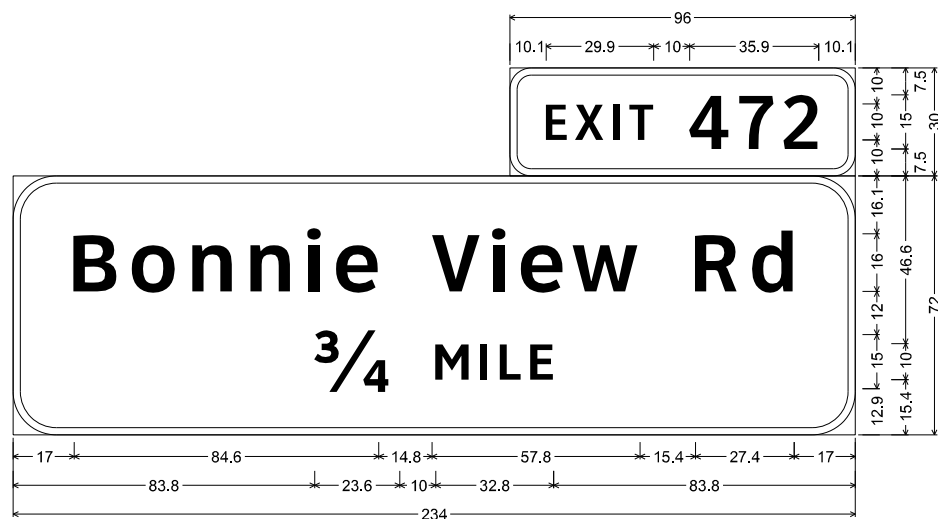

6.0" Radius, 2.0" Border, White on Green;
 "EXIT 472", ClearviewHwy-4-W;
 12.0" Radius, 2.0" Border, White on Green;
 "Bonnie View Rd", ClearviewHwy-5-W-R; "3/4", ClearviewHwy-5-W-R; "MILE", ClearviewHwy-5-W-R;

SHEET 31 SIGN 5

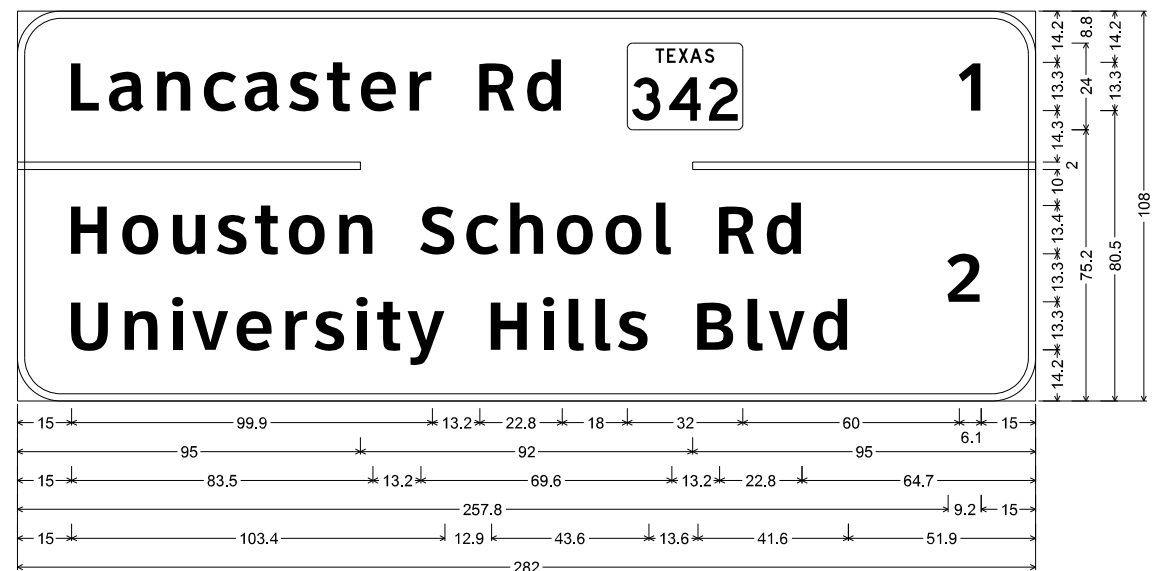

12.0" Radius, 2.0" Border, White on Green;
 "Lancaster Rd", ClearviewHwy-5-W-R; State Highway 342 M1-6T3; "1", ClearviewHwy-5-W-R;
 "Houston School Rd", ClearviewHwy-5-W-R; "2", ClearviewHwy-5-W-R; "University Hills Blvd", ClearviewHwy-5-W-R;

SHEET 32 SIGN 1

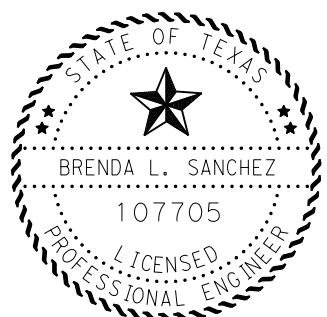

Brenda L Sanchez, P.E. 03/20/23
 Signature of Registrant & Date



6.0" Radius, 2.0" Border, White on Green;
 "EXIT", ClearviewHwy-4-W; "473", ClearviewHwy-4-W;
 "B-C", ClearviewHwy-4-W;
 12.0" Radius, 2.0" Border, White on Green;
 State Name 45 M1-1T; "Dallas", ClearviewHwy-5-W-R;
 "Houston", ClearviewHwy-5-W-R; "1 3/4", ClearviewHwy-5-W-R;
 "MILES", ClearviewHwy-5-W-R;

SHEET 32 SIGN 2

Texas Department of Transportation © 2023			
GUIDE SIGN DETAILS			
SCALE: NTS		SHEET 18 OF 47	
DESIGN/CK BLS	FED. RD. DIV. NO. 6	STATE PROJECT NO. (SEE TITLE SHEET)	
CHECK BLS	STATE	DISTRICT DAL	COUNTY VARIOUS
CHECK MA	TEXAS	CONTROL SECTION JOB	
CHECK BA	0095	14	033, ETC
			IH 20 SHEET NO. 243

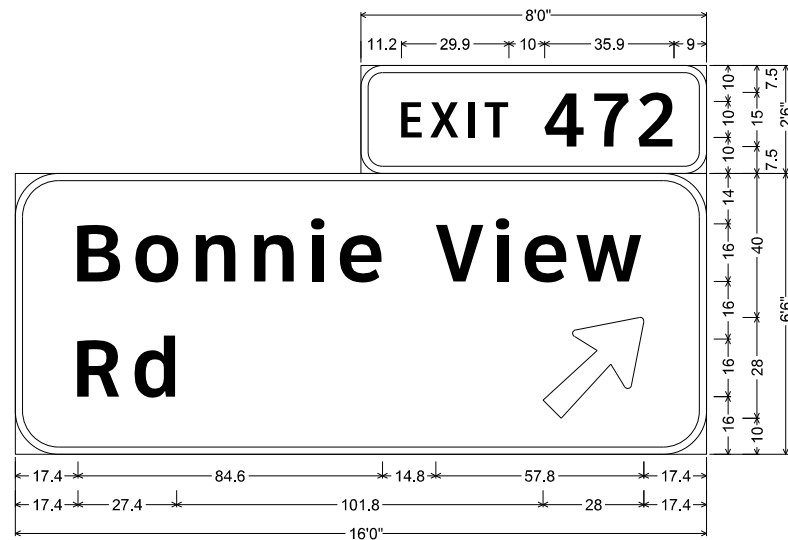

6.0" Radius, 2.0" Border, White on Green;
 "EXIT 472", ClearviewHwy-4-W;
 12.0" Radius, 2.0" Border, White on Green;
 "Bonnie View", ClearviewHwy-5-W-R; "Rd", ClearviewHwy-5-W-R; Arrow A-3 - 35.6" 45°;

SHEET 32 SIGN 3

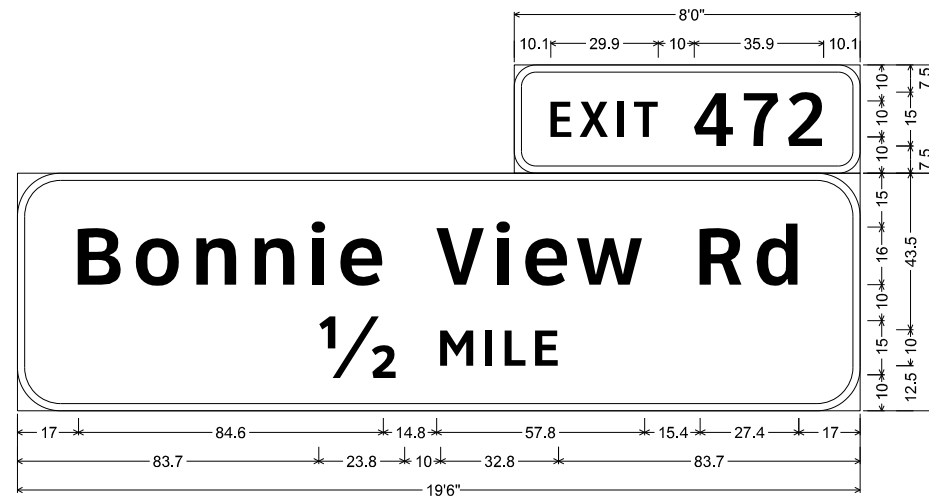

6.0" Radius, 2.0" Border, White on Green;
 "EXIT 472", ClearviewHwy-4-W;
 12.0" Radius, 2.0" Border, White on Green;
 "Bonnie View Rd", ClearviewHwy-5-W-R; "1/2", ClearviewHwy-5-W-R; "MILE", ClearviewHwy-5-W-R;

SHEET 34 SIGN 1

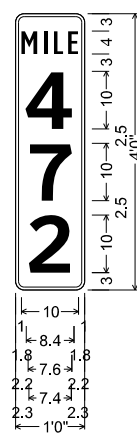

D10-3 10in;
 1.5" Radius, 0.5" Border, White on Green;
 "MILE", ClearviewHwy-2-W;
 "4", ClearviewHwy-6-W;
 "7", ClearviewHwy-6-W;
 "2", ClearviewHwy-6-W;

SHEET 33 SIGN 1
 SHEET 33 SIGN 2

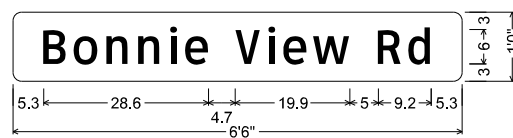

D3-1G(1) 6in;
 1.5" Radius, No border, White on Green;
 "Bonnie View Rd", ClearviewHwy-3-W;

SHEET 33 SIGN 3
 SHEET 33 SIGN 5

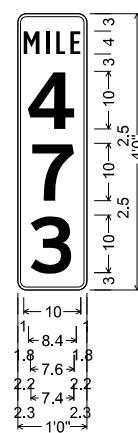

D10-3 10in;
 1.5" Radius, 0.5" Border, White on Green;
 "MILE", ClearviewHwy-2-W;
 "4", ClearviewHwy-6-W;
 "7", ClearviewHwy-6-W;
 "3", ClearviewHwy-6-W;

SHEET 35 SIGN 1
 SHEET 35 SIGN 2

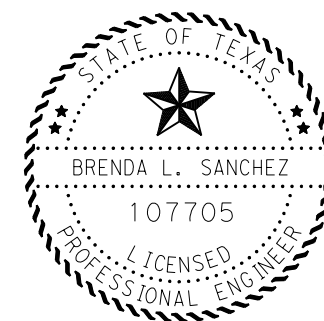

Brenda L Sanchez, P.E. 03/20/23
 Signature of Registrant & Date

 © 2023				
GUIDE SIGN DETAILS				
SCALE: NTS			SHEET 19 OF 47	
DESIGN/CK	FED. RD. DIV. NO.	STATE PROJECT NO.		HIGHWAY NO.
BLS	6	(SEE TITLE SHEET)		IH 20
CHECK	STATE	DISTRICT	COUNTY	SHEET NO.
BLS	TEXAS	DAL	VARIOUS	244
CHECK	CONTROL	SECTION	JOB	
MA	0095	14	033, ETC	
CHECK	BA			

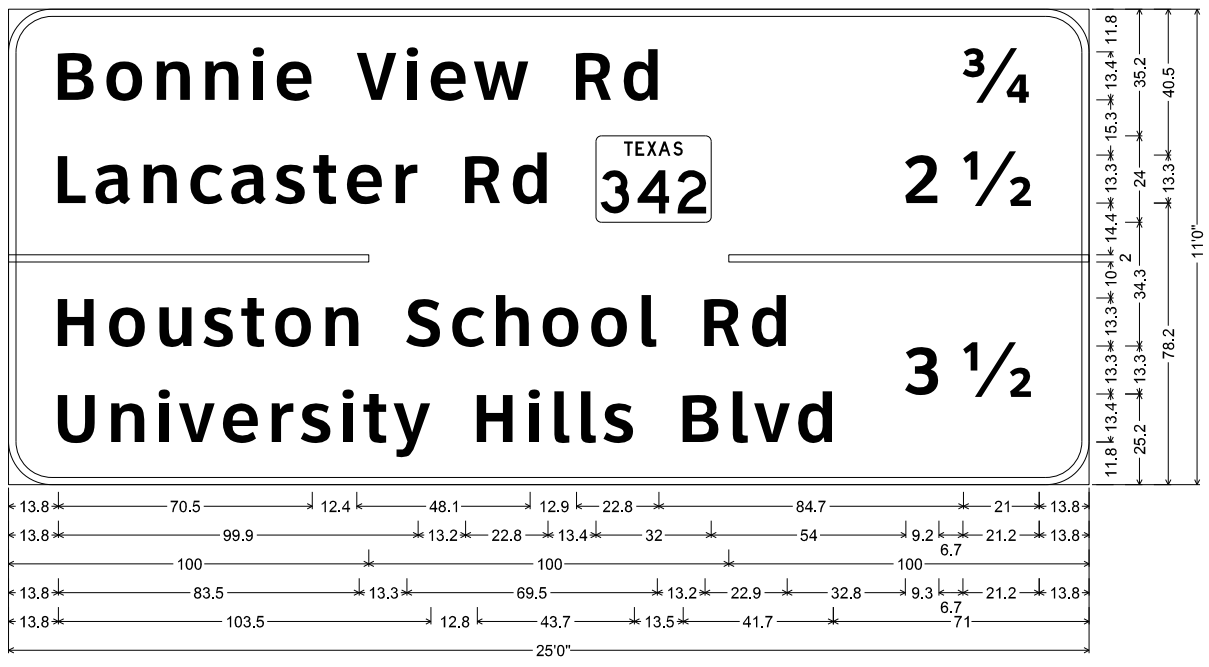

12.0" Radius, 2.0" Border, White on Green;
 "Bonnie View Rd", ClearviewHwy-5-W-R; "3/4", ClearviewHwy-5-W-R; "Lancaster Rd", ClearviewHwy-5-W-R; State Highway 342 M1-6T3;
 "2 1/2", ClearviewHwy-5-W-R; "Houston School Rd", ClearviewHwy-5-W-R; "University Hills Blvd", ClearviewHwy-5-W-R;
 "3 1/2", ClearviewHwy-5-W-R;

SHEET 35 SIGN 3

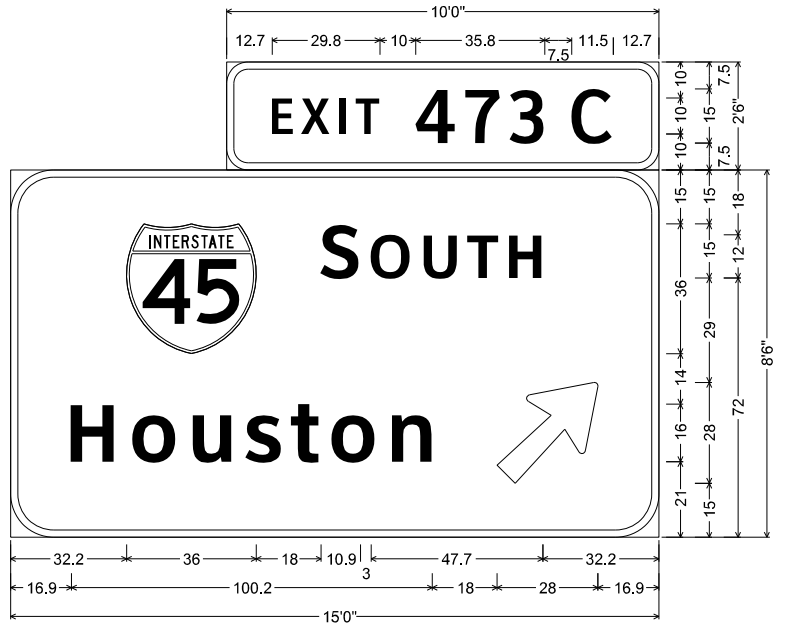

6.0" Radius, 2.0" Border, White on Green; "EXIT 473 C", ClearviewHwy-4-W;
 12.0" Radius, 2.0" Border, White on Green; Interstate 45 M1-1; "S OUTH", ClearviewHwy-5-W-R; "Houston", ClearviewHwy-5-W-R; Arrow A-3 - 35.6" 45";
 SHEET 35 SIGN 5
 SHEET 36 SIGN 8



6.0" Radius, 2.0" Border, White on Green; "EXIT 473 B", ClearviewHwy-4-W;
 12.0" Radius, 2.0" Border, White on Green; Interstate 45 M1-1; "N ORTH", ClearviewHwy-5-W-R; "Dallas", ClearviewHwy-5-W-R; "1/4 MILE", ClearviewHwy-5-W-R;

SHEET 35 SIGN 6
 SHEET 36 SIGN 7

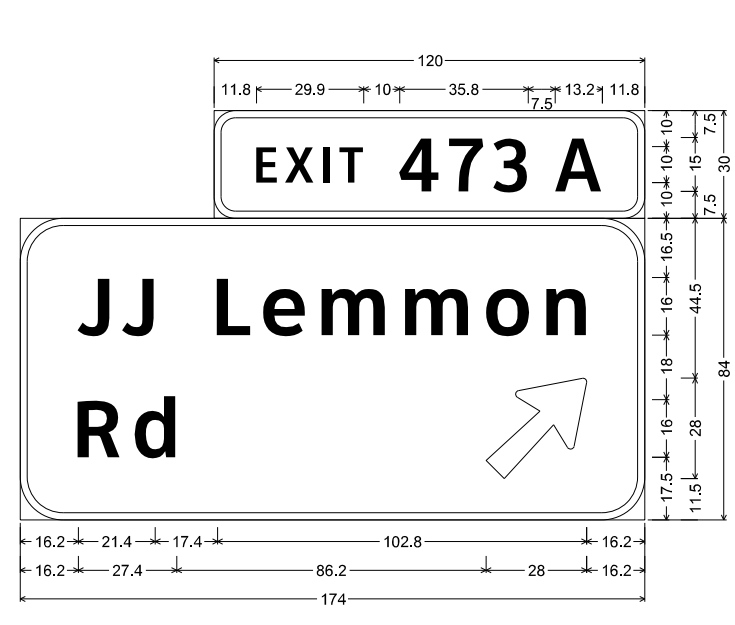

6.0" Radius, 2.0" Border, White on Green; "EXIT", ClearviewHwy-4-W; "473", ClearviewHwy-4-W; "A", ClearviewHwy-4-W;
 12.0" Radius, 2.0" Border, White on Green; "JJ Lemmon", ClearviewHwy-5-W-R; "Rd", ClearviewHwy-5-W-R; Arrow A-3 - 35.6" 45";

SHEET 35 SIGN 7

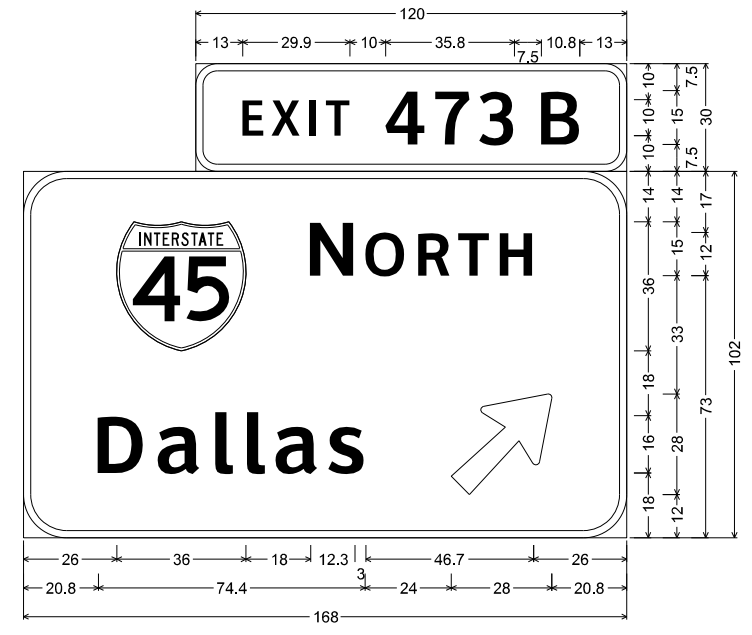

6.0" Radius, 2.0" Border, White on Green; "EXIT 473 B", ClearviewHwy-4-W;
 12.0" Radius, 2.0" Border, White on Green; Interstate 45 M1-1; "N ORTH", ClearviewHwy-5-W-R; "Dallas", ClearviewHwy-5-W-R; Arrow A-3 - 35.6" 45";

SHEET 36 SIGN 2

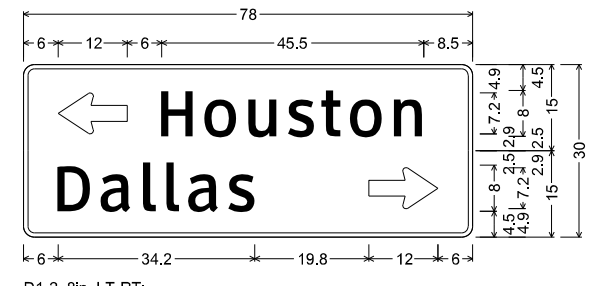

D1-2 8in LT-RT;
 1.9" Radius, 0.8" Border, White on Green; Standard Arrow Custom 12.0" X 7.1" 180°; "Houston", ClearviewHwy-3-W;
 1.9" Radius, 0.8" Border, White on Green; "Dallas", ClearviewHwy-3-W; Standard Arrow Custom 12.0" X 7.1" 0°;

SHEET 36 SIGN 3

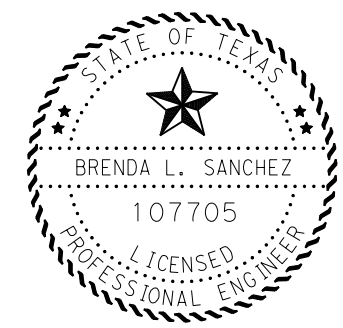

Brenda L Sanchez, P.E. 03/20/23
 Signature of Registrant & Date

GUIDE SIGN DETAILS

SCALE: NTS SHEET 20 OF 47

DESIGN/CK	FED. RD. DIV. NO.	STATE PROJECT NO.		HIGHWAY NO.
BLS	6	(SEE TITLE SHEET)		IH 20
CHECK	STATE	DISTRICT	COUNTY	SHEET NO.
BLS	TEXAS	DAL	VARIOUS	245
CHECK	CONTROL	SECTION	JOB	
MA	0095	14	033, ETC	
CHECK	BA			

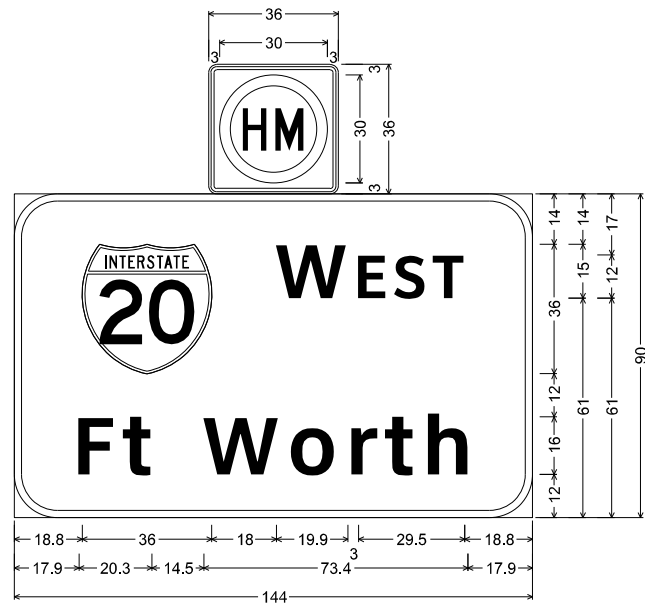

R14-2_36x36;
2.3" Radius, 0.9" Border, 0.6" Indent, Black on White;
12.0" Radius, 2.0" Border, White on Green;
Interstate 20 M1-1; "W EST", ClearviewHwy-5-W-R;
"Ft Worth", ClearviewHwy-5-W-R;

SHEET 36 SIGN 6
SHEET 112 SIGN 5

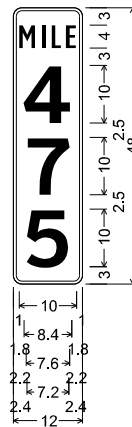

D10-3 10in;
1.5" Radius, 0.5" Border, White on Green;
"MILE", ClearviewHwy-2-W;
"4", ClearviewHwy-6-W;
"7", ClearviewHwy-6-W;
"5", ClearviewHwy-6-W;

SHEET 39 SIGN 1
SHEET 39 SIGN 2

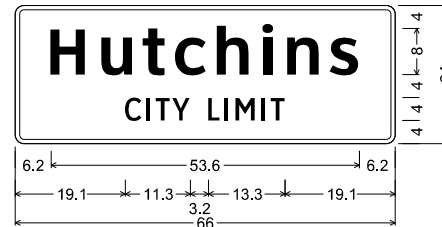

I-2aT 8in;
1.5" Radius, 0.8" Border, White on Green;
"Hutchins", ClearviewHwy-5-W-R;
"CITY LIMIT", ClearviewHwy-3-W;

SHEET 37 SIGN 3
SHEET 40 SIGN 1

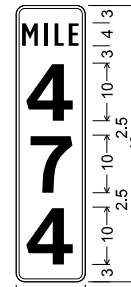

D10-3 10in;
1.5" Radius, 0.5" Border, White on Green;
"MILE", ClearviewHwy-2-W;
"4", ClearviewHwy-6-W;
"7", ClearviewHwy-6-W;
"4", ClearviewHwy-6-W;

SHEET 37 SIGN 4
SHEET 37 SIGN 5

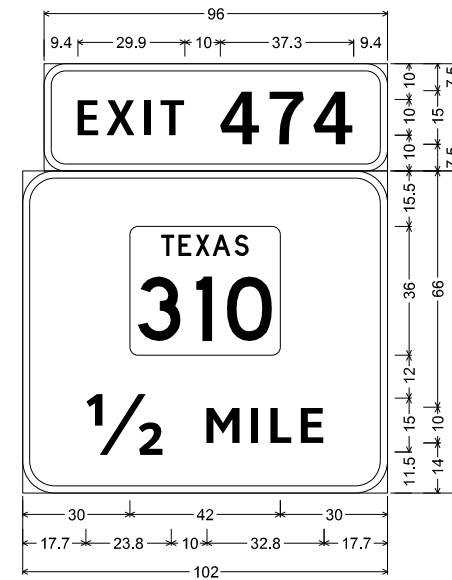

6.0" Radius, 2.0" Border, White on Green;
"EXIT 474", ClearviewHwy-4-W;
9.0" Radius, 2.0" Border, White on Green;
State Highway 310 M1-6T3;
"1/2", ClearviewHwy-5-W-R;
"MILE", ClearviewHwy-5-W-R;

SHEET 38 SIGN 1

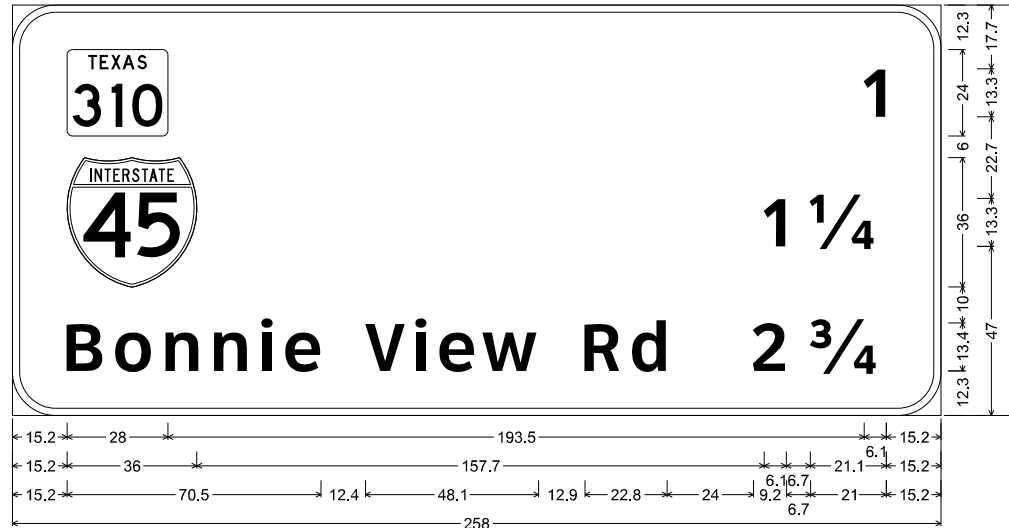

12.0" Radius, 2.0" Border, White on Green;
State Highway 310 M1-6T3; "1", ClearviewHwy-5-W-R; Interstate 45 M1-1; "1 1/4", ClearviewHwy-5-W-R;
"Bonnie View Rd", ClearviewHwy-5-W-R; "2 3/4", ClearviewHwy-5-W-R;

SHEET 39 SIGN 3

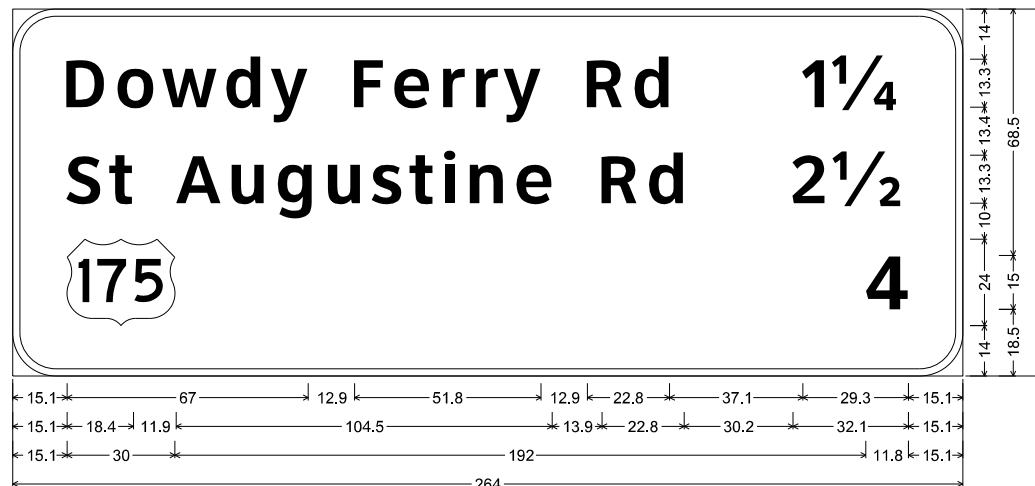

12.0" Radius, 2.0" Border, White on Green;
"Dowdy Ferry Rd", ClearviewHwy-5-W-R; "1 1/4", ClearviewHwy-5-W-R; "St Augustine Rd", ClearviewHwy-5-W-R;
"2 1/2", ClearviewHwy-5-W-R; US 175 M1-4; "4", ClearviewHwy-5-W-R;

SHEET 39 SIGN 4

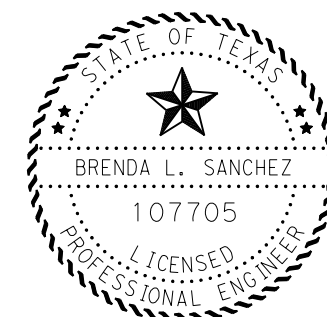

Brenda L Sanchez, P.E. 03/20/23
Signature of Registrar & Date



6.0" Radius, 2.0" Border, White on Green;
"EXIT 473 C-B", ClearviewHwy-4-W;
12.0" Radius, 2.0" Border, White on Green;
Interstate 45 M1-1; "Houston", ClearviewHwy-5-W-R;
"Dallas", ClearviewHwy-5-W-R; "1", ClearviewHwy-5-W-R;
"MILE", ClearviewHwy-5-W-R;

SHEET 38 SIGN 2

GUIDE SIGN DETAILS

SCALE: NTS SHEET 21 OF 47

DESIGN/CK BLS	FED. RD. DIV. NO. 6	STATE PROJECT NO. (SEE TITLE SHEET)		HIGHWAY NO. IH 20
CHECK BLS	STATE	DISTRICT DAL	COUNTY VARIOUS	SHEET NO. 246
CHECK MA	TEXAS	CONTROL	SECTION JOB	
CHECK BA	0095	14	033, ETC	

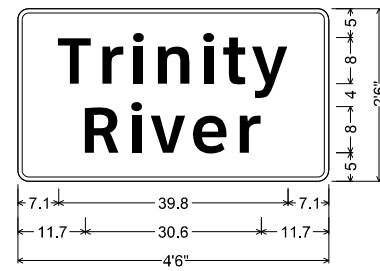

I-3 8in;
1.9" Radius, 0.8" Border, White on Green;
"Trinity", ClearviewHwy-5-W-R;
"River", ClearviewHwy-5-W-R;

SHEET 40 SIGN 2
SHEET 40 SIGN 4

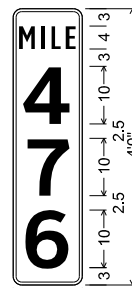

D10-3 10in;
1.5" Radius, 0.5" Border, White on Green;
"MILE", ClearviewHwy-2-W;
"4", ClearviewHwy-6-W;
"7", ClearviewHwy-6-W;
"6", ClearviewHwy-6-W;

SHEET 40 SIGN 5
SHEET 40 SIGN 6

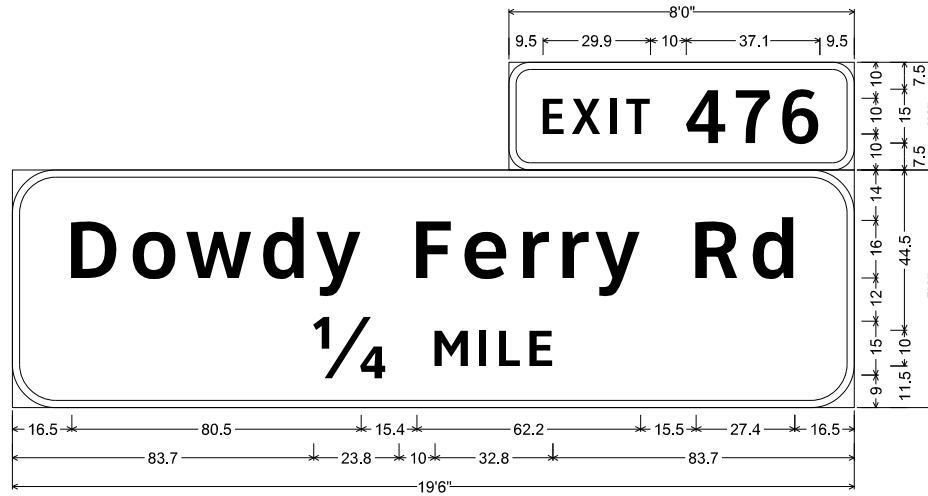

6.0" Radius, 2.0" Border, White on Green;
"EXIT 476", ClearviewHwy-4-W;
12.0" Radius, 2.0" Border, White on Green;
"Dowdy Ferry Rd", ClearviewHwy-5-W-R; "1/4 MILE", ClearviewHwy-5-W-R;

SHEET 41 SIGN 1
SHEET 43 SIGN 1

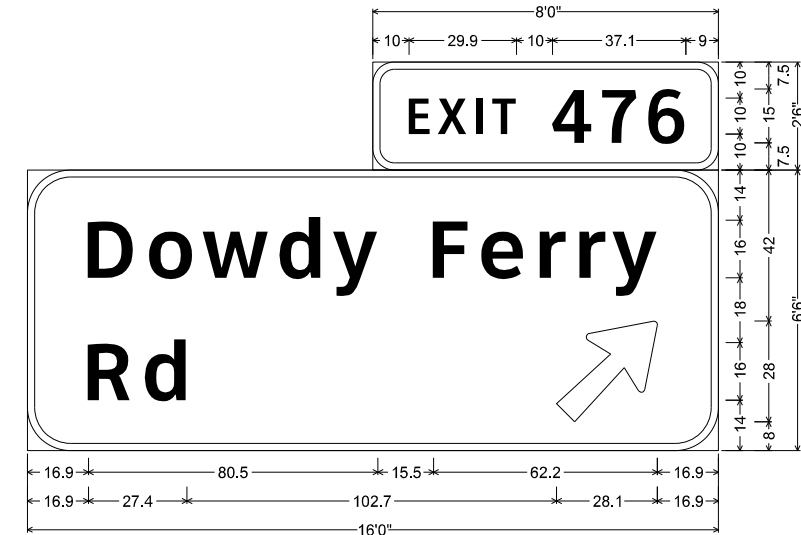

6.0" Radius, 2.0" Border, White on Green;
"EXIT 476", ClearviewHwy-4-W;
12.0" Radius, 2.0" Border, White on Green;
"Dowdy Ferry", ClearviewHwy-5-W-R; "Rd", ClearviewHwy-5-W-R; Arrow A-3 - 35.6" 45°;

SHEET 41 SIGN 2
SHEET 42 SIGN 4

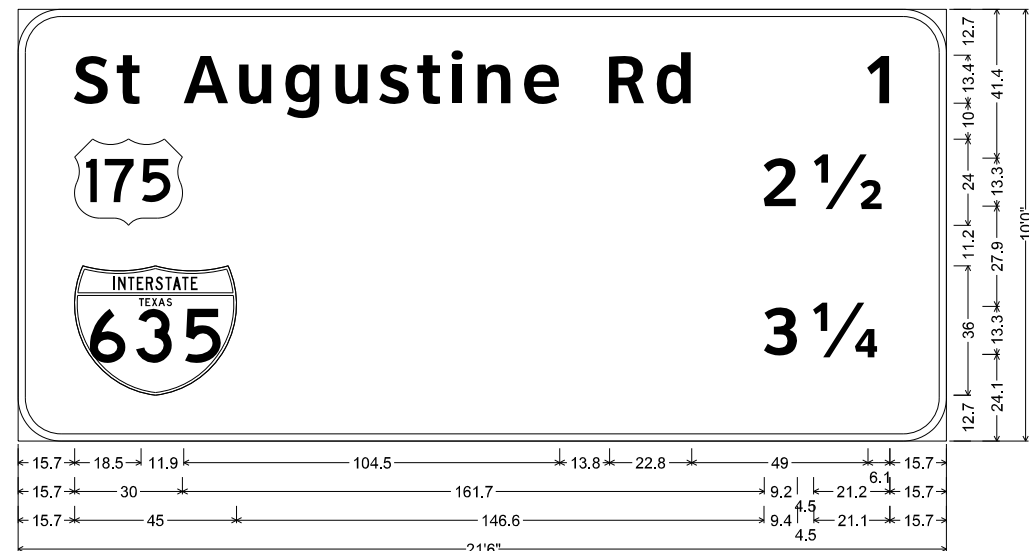

12.0" Radius, 2.0" Border, White on Green;
"St Augustine Rd", ClearviewHwy-5-W-R; "1", ClearviewHwy-5-W-R; US 175 M1-4; "2 1/2", ClearviewHwy-5-W-R;
State Name 635 M1-1T; "3 1/4", ClearviewHwy-5-W-R;

SHEET 42 SIGN 1

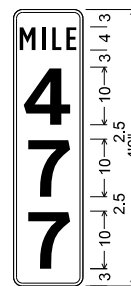

D10-3 10in;
1.5" Radius, 0.5" Border, White on Green;
"MILE", ClearviewHwy-2-W;
"4", ClearviewHwy-6-W;
"7", ClearviewHwy-6-W;
"7", ClearviewHwy-6-W;

SHEET 42 SIGN 5
SHEET 42 SIGN 6

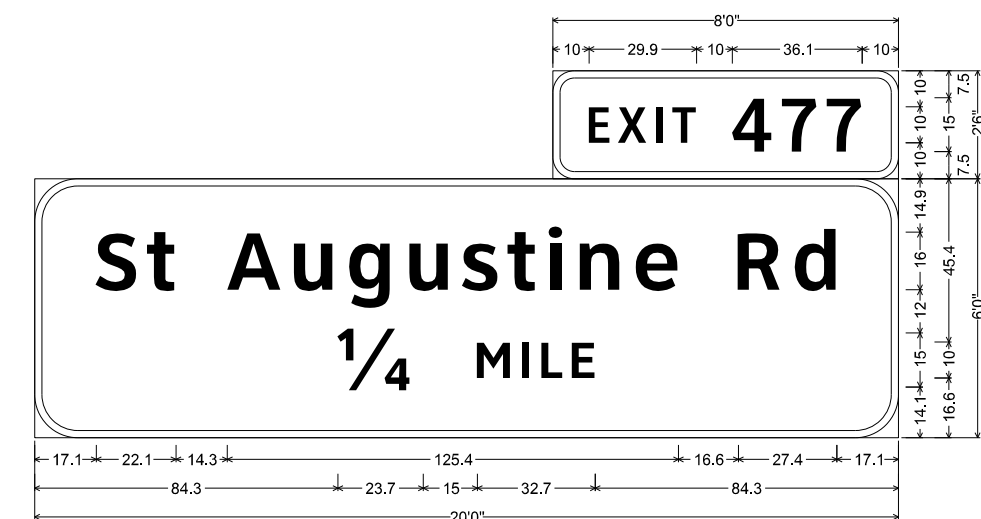

6.0" Radius, 2.0" Border, White on Green;
"EXIT 477", ClearviewHwy-4-W;
12.0" Radius, 2.0" Border, White on Green;
"St Augustine Rd", ClearviewHwy-5-W-R; "1/4", ClearviewHwy-5-W-R; "MILE", ClearviewHwy-5-W-R;

SHEET 43 SIGN 2

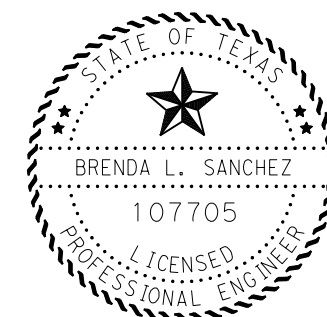

Brenda L Sanchez, P.E. 03/20/23
Signature of Registrant & Date

 © 2023			
GUIDE SIGN DETAILS			
SCALE: NTS		SHEET 22 OF 47	
DESIGN/CK BLS	FED. RD. DIV. NO. 6	STATE PROJECT NO. (SEE TITLE SHEET)	
CHECK BLS	STATE	DISTRICT DAL	COUNTY VARIOUS
CHECK MA	TEXAS	SECTION CONTROL	JOB 033, ETC
CHECK BA	0095	14	247

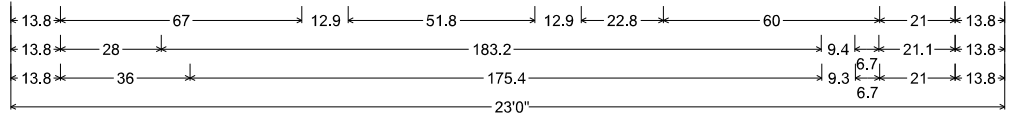
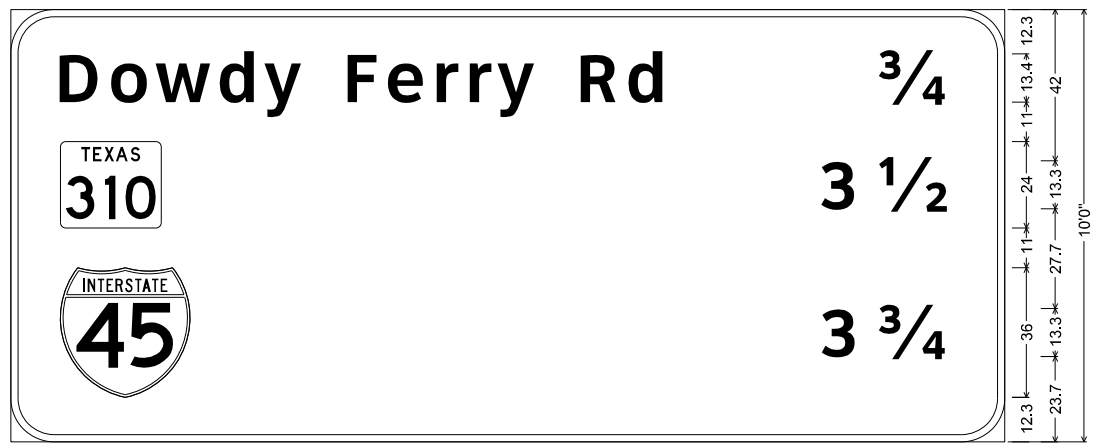

12.0" Radius, 2.0" Border, White on Green;
 "Dowdy Ferry Rd", ClearviewHwy-5-W-R; "3/4", ClearviewHwy-5-W-R; State Highway 310 M1-6T3; "3 1/2", ClearviewHwy-5-W-R;
 Interstate 45 M1-1; "3 3/4", ClearviewHwy-5-W-R;

SHEET 44 SIGN 1

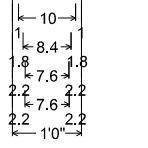
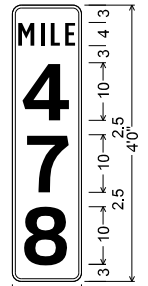

D10-3 10in;
 1.5" Radius, 0.5" Border, White on Green;
 "MILE", ClearviewHwy-2-W;
 "4", ClearviewHwy-6-W;
 "7", ClearviewHwy-6-W;
 "8", ClearviewHwy-6-W;

SHEET 44 SIGN 2
SHEET 44 SIGN 3

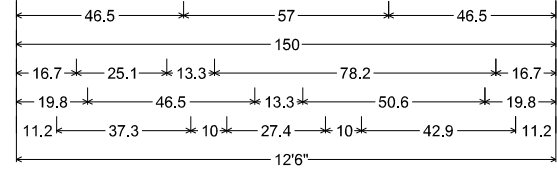

12.0" Radius, 2.0" Border, Black on White;
 "BEGIN", E; "NO TRUCKS", E; "LEFT LANE", E;
 "NEXT 50 MILES", E;

SHEET 44 SIGN 5

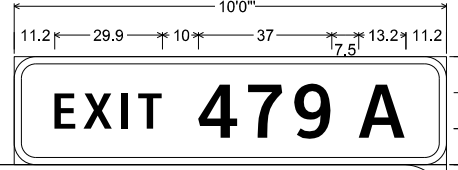

6.0" Radius, 2.0" Border, White on Green;
 "EXIT", ClearviewHwy-4-W; "479 A", ClearviewHwy-4-W;
 12.0" Radius, 2.0" Border, White on Green;
 US 175 M1-4; "W EST", ClearviewHwy-5-W-R;
 "Dallas", ClearviewHwy-5-W-R; "1", ClearviewHwy-5-W-R;
 "MILE", ClearviewHwy-5-W-R;

SHEET 45 SIGN 2

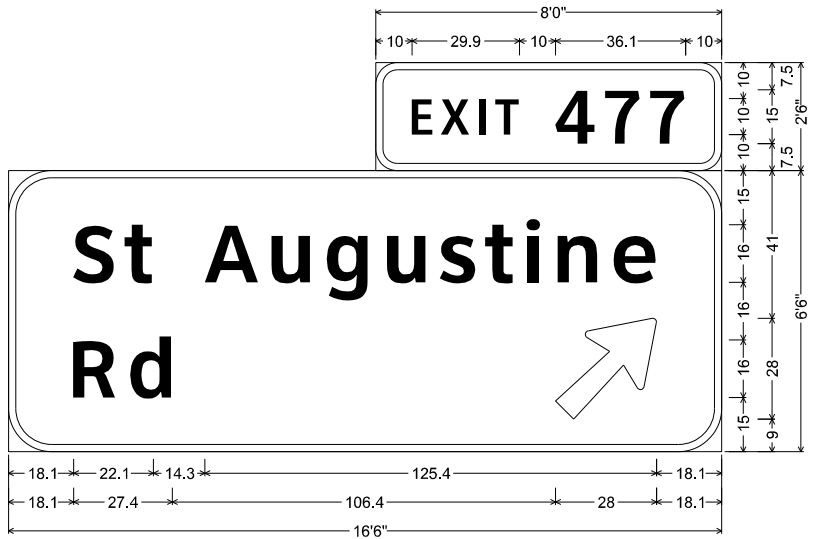

6.0" Radius, 2.0" Border, White on Green;
 "EXIT 477", ClearviewHwy-4-W;
 12.0" Radius, 2.0" Border, White on Green;
 "St Augustine", ClearviewHwy-5-W-R; "Rd", ClearviewHwy-5-W-R; Arrow A-3 - 35.6" 45";

SHEET 44 SIGN 6

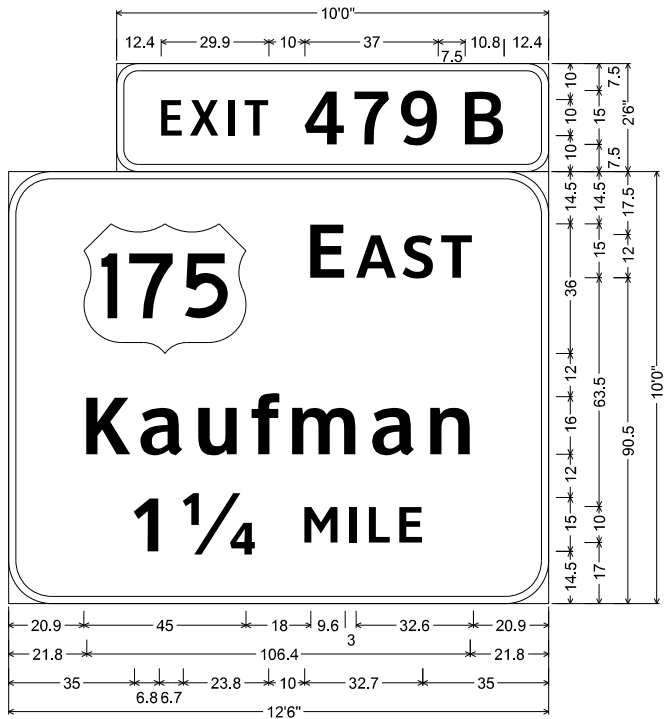

6.0" Radius, 2.0" Border, White on Green;
 "EXIT", ClearviewHwy-4-W; "479 B", ClearviewHwy-4-W;
 12.0" Radius, 2.0" Border, White on Green;
 US 175 M1-4; "E AST", ClearviewHwy-5-W-R;
 "Kaufman", ClearviewHwy-5-W-R; "1 1/4", ClearviewHwy-5-W-R;
 "MILE", ClearviewHwy-5-W-R;

SHEET 45 SIGN 1

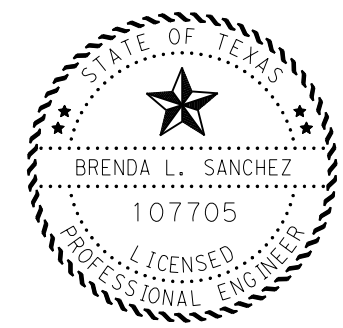

Brenda L Sanchez, P.E. 03/20/23
 Signature of Registrar & Date

			
GUIDE SIGN DETAILS			
SCALE: NTS		SHEET 23 OF 47	
DESIGN/CK BLS	FED. RD. DIV. NO. 6	STATE PROJECT NO. (SEE TITLE SHEET)	HIGHWAY NO. IH 20
CHECK BLS	STATE TEXAS	DISTRICT DAL	COUNTY VARIOUS
CHECK MA	CONTROL 0095	SECTION 14	JOB 033, ETC
CHECK BA			248

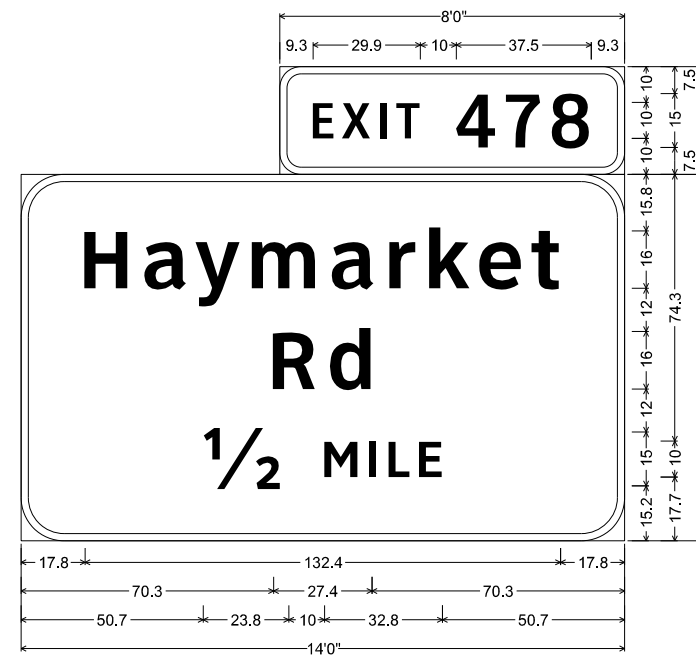

6.0" Radius, 2.0" Border, White on Green;
 "EXIT", ClearviewHwy-4-W; "478", ClearviewHwy-4-W;
 12.0" Radius, 2.0" Border, White on Green;
 "Haymarket", ClearviewHwy-5-W-R; "Rd", ClearviewHwy-5-W-R;
 "1/2", ClearviewHwy-5-W-R; "MILE", ClearviewHwy-5-W-R;

SHEET 45 SIGN 3

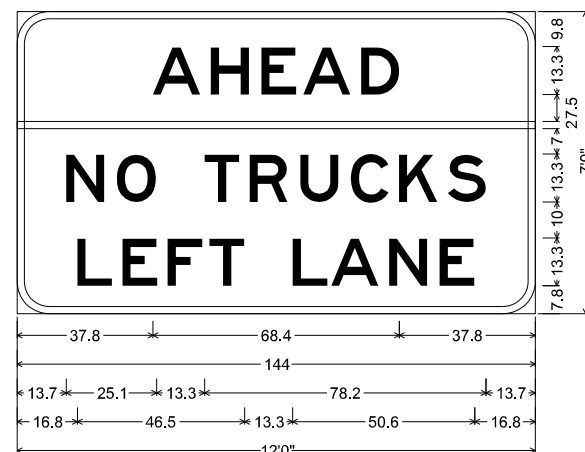

9.0" Radius, 2.0" Border, Black on White;
 "AHEAD", E; "NO TRUCKS", E; "LEFT LANE", E;

SHEET 46 SIGN 4
SHEET 61 SIGN 4

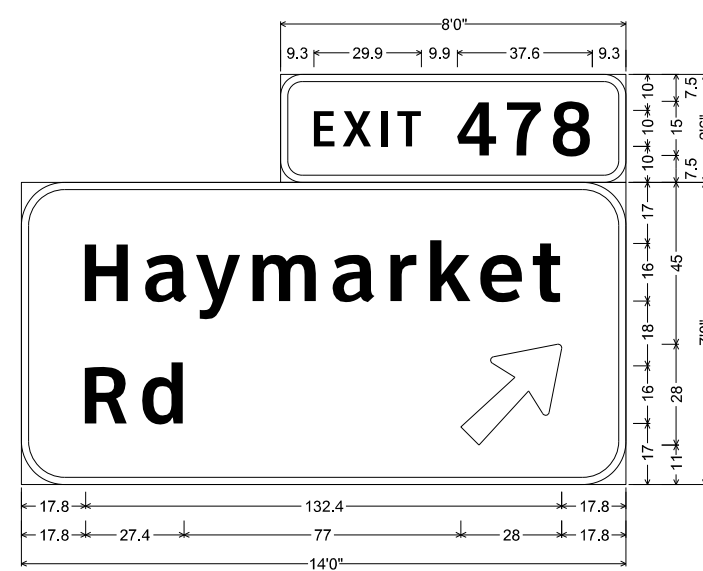

6.0" Radius, 2.0" Border, White on Green;
 "EXIT 478", ClearviewHwy-4-W;
 12.0" Radius, 2.0" Border, White on Green;
 "Haymarket", ClearviewHwy-5-W-R; "Rd", ClearviewHwy-5-W-R;
 Arrow A-3 - 35.6" 45";

SHEET 45 SIGN 4

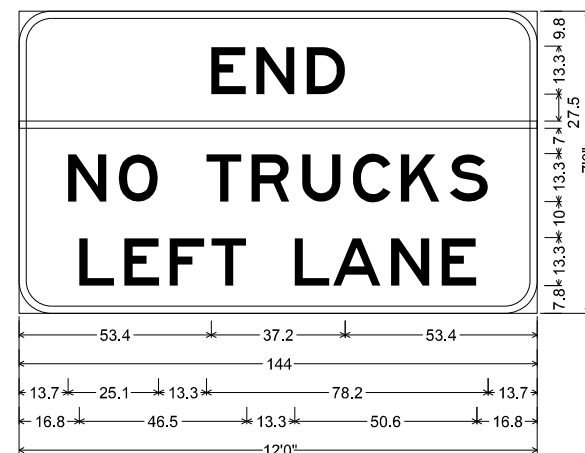

9.0" Radius, 2.0" Border, Black on White;
 "END", E; "NO TRUCKS", E; "LEFT LANE", E;

SHEET 46 SIGN 7
SHEET 49 SIGN 4
SHEET 61 SIGN 5
SHEET 113 SIGN 2

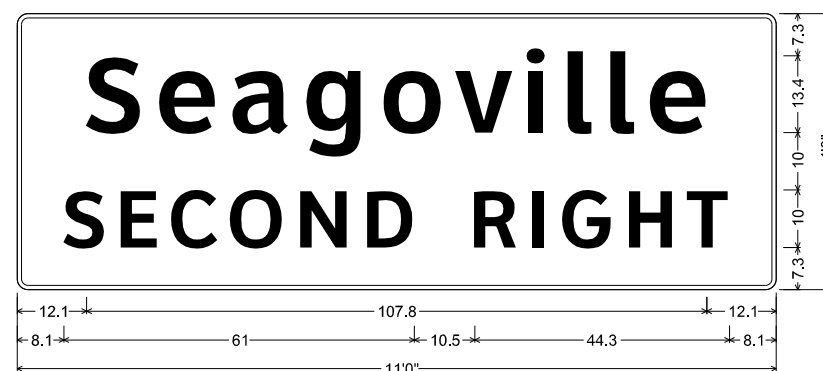

D3-2(1)_VARx30;
 1.9" Radius, 0.8" Border, White on Green;
 "Seagoville", ClearviewHwy-5-W-R; "SECOND RIGHT", ClearviewHwy-5-W-R;

SHEET 46 SIGN 6

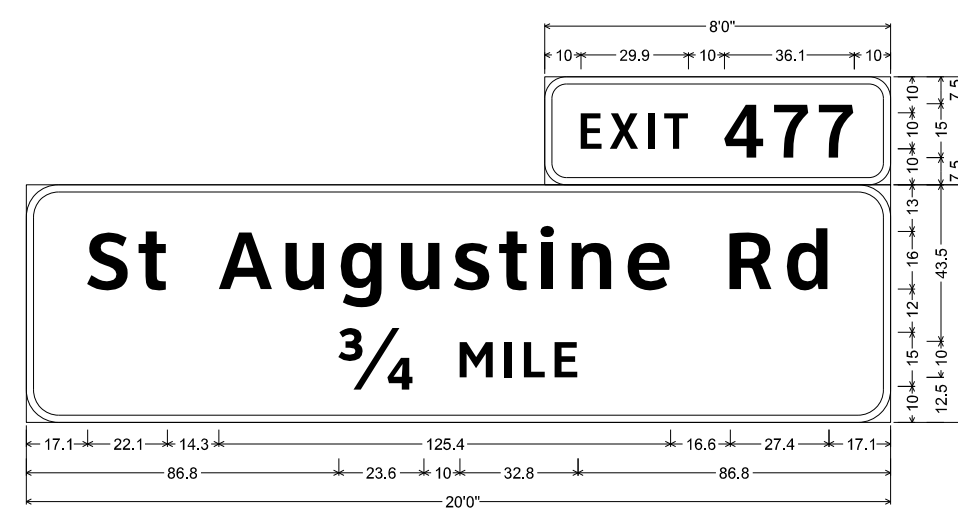

6.0" Radius, 2.0" Border, White on Green;
 "EXIT 477", ClearviewHwy-4-W;
 9.0" Radius, 2.0" Border, White on Green;
 "St Augustine Rd", ClearviewHwy-5-W-R; "3/4 MILE", ClearviewHwy-5-W-R;

SHEET 46 SIGN 1

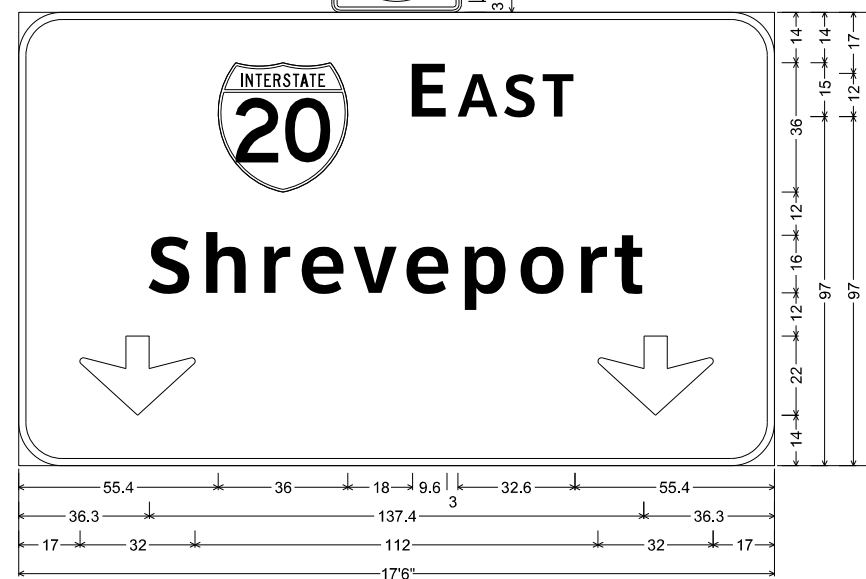
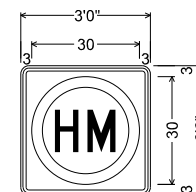

R14-2_36x36;
 2.3" Radius, 0.9" Border, 0.6" Indent, Black on White;
 12.0" Radius, 2.0" Border, White on Green;
 Interstate 20 M1-1; "E AST", ClearviewHwy-5-W-R; "Shreveport", ClearviewHwy-5-W-R;
 Down Arrow 22 - 22.0" 270"; Down Arrow 22 - 22.0" 270";

SHEET 46 SIGN 8

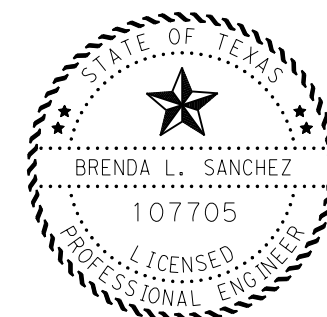

Brenda L Sanchez, P.E. 03/20/23
 Signature of Registrar & Date

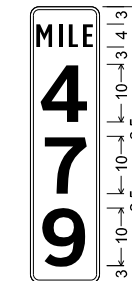

D10-3 10in;
 1.5" Radius, 0.5" Border, White on Green;
 "MILE", ClearviewHwy-2-W;
 "4", ClearviewHwy-6-W;
 "7", ClearviewHwy-6-W;
 "9", ClearviewHwy-6-W;

SHEET 46 SIGN 2
SHEET 46 SIGN 3



GUIDE SIGN DETAILS

SCALE: NTS SHEET 24 OF 47

DESIGN/CK	FED. RD. DIV. NO.	STATE PROJECT NO.		HIGHWAY NO.
BLS	6	(SEE TITLE SHEET)		IH 20
CHECK	STATE	DISTRICT	COUNTY	SHEET NO.
BLS	TEXAS	DAL	VARIOUS	249
CHECK	CONTROL	SECTION	JOB	
MA	0095	14	033, ETC	
CHECK	BA			

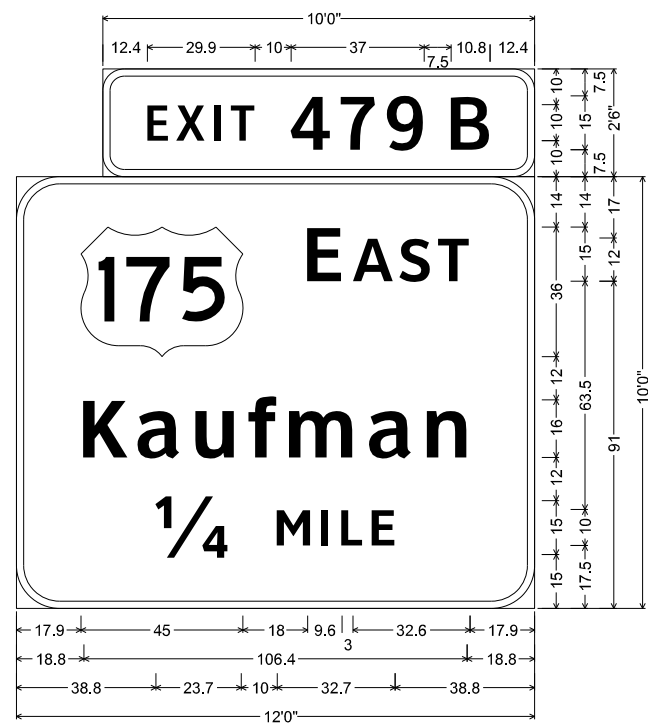

6.0" Radius, 2.0" Border, White on Green;
 "EXIT", ClearviewHwy-4-W; "479 B", ClearviewHwy-4-W;
 12.0" Radius, 2.0" Border, White on Green;
 US 175 M1-4; "E AST", ClearviewHwy-5-W-R;
 "Kaufman", ClearviewHwy-5-W-R; "1/4", ClearviewHwy-5-W-R;
 "MILE", ClearviewHwy-5-W-R;

SHEET 46 SIGN 9

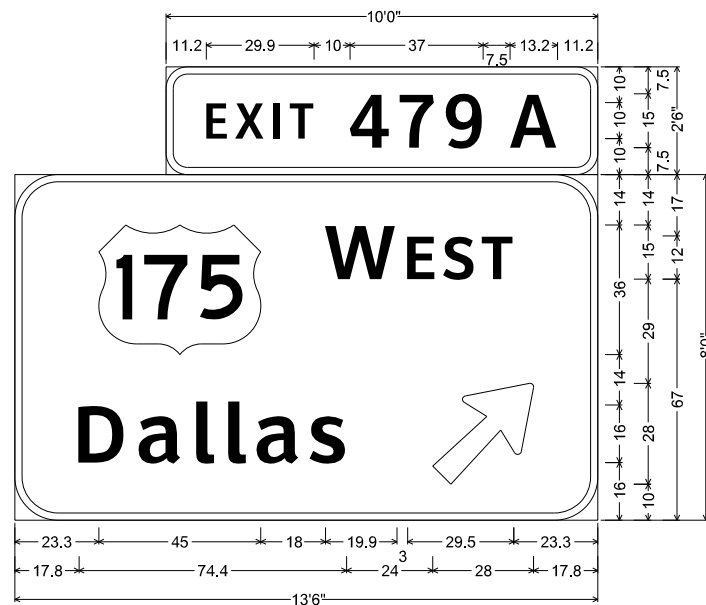

6.0" Radius, 2.0" Border, White on Green;
 "EXIT", ClearviewHwy-4-W; "479 A", ClearviewHwy-4-W;
 12.0" Radius, 2.0" Border, White on Green;
 US 175 M1-4; "W EST", ClearviewHwy-5-W-R;
 "Dallas", ClearviewHwy-5-W-R; Arrow A-3 - 35.6" 45°;

SHEET 46 SIGN 10
SHEET 47 SIGN 5

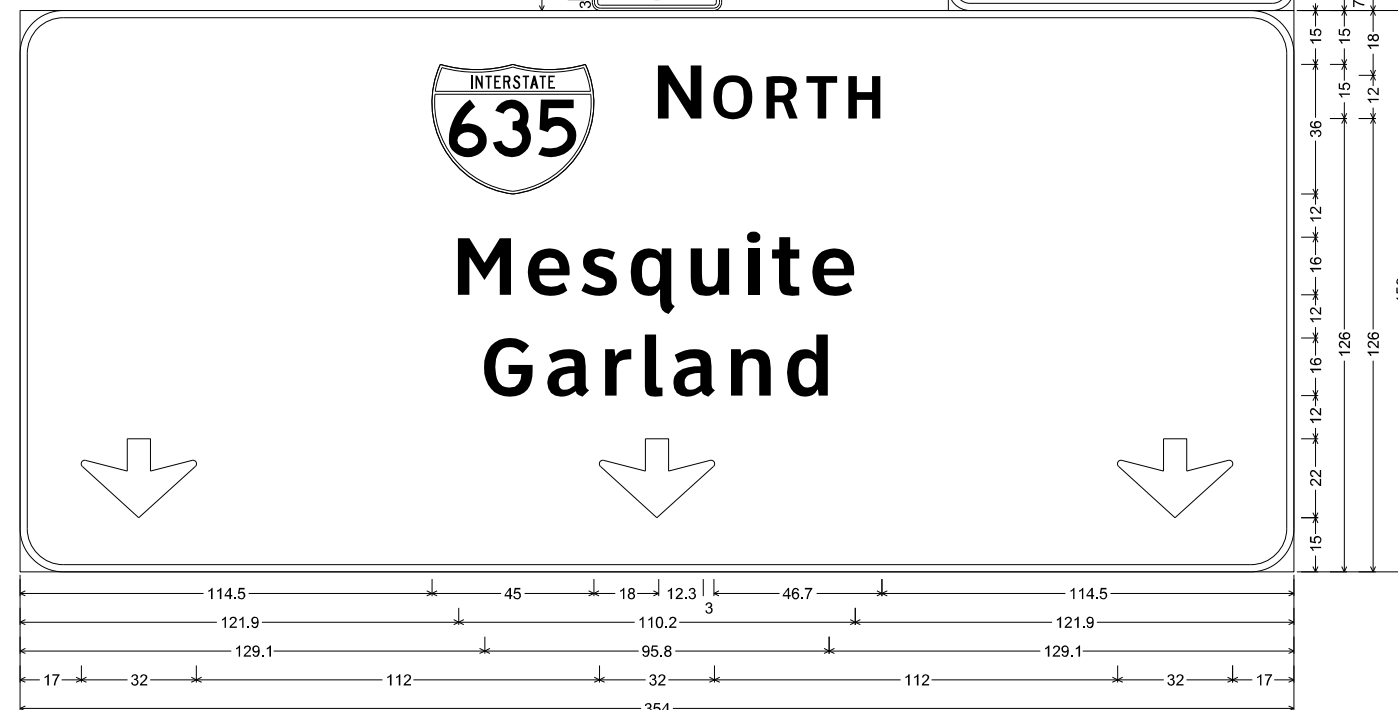
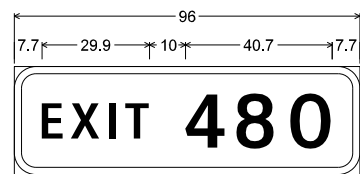
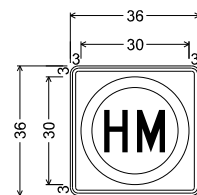

R14-2_36x36;
 2.3" Radius, 0.9" Border, 0.6" Indent, Black on White;
 6.0" Radius, 2.0" Border, White on Green;
 "EXIT", ClearviewHwy-4-W; "480", ClearviewHwy-4-W;
 12.0" Radius, 2.0" Border, White on Green;
 Interstate 635 M1-1 16.0" D; "N ORTH", ClearviewHwy-5-W-R; "Mesquite", ClearviewHwy-5-W-R; "Garland", ClearviewHwy-5-W-R; Down Arrow 22 - 22.0" 270°;
 Down Arrow 22 - 22.0" 270°; Down Arrow 22 - 22.0" 270°;

SHEET 47 SIGN 8
SHEET 48 SIGN 9

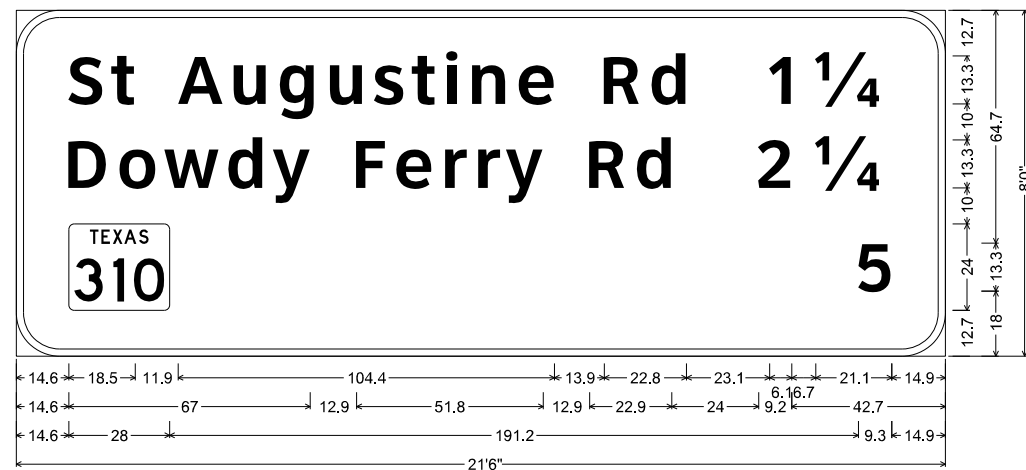

12.0" Radius, 2.0" Border, White on Green;
 "St Augustine Rd", ClearviewHwy-5-W-R; "1 1/4", ClearviewHwy-5-W-R; "Dowdy Ferry Rd", ClearviewHwy-5-W-R;
 "2 1/4", ClearviewHwy-5-W-R; State Highway 310 M1-6T3; "5", ClearviewHwy-5-W-R;

SHEET 47 SIGN 1

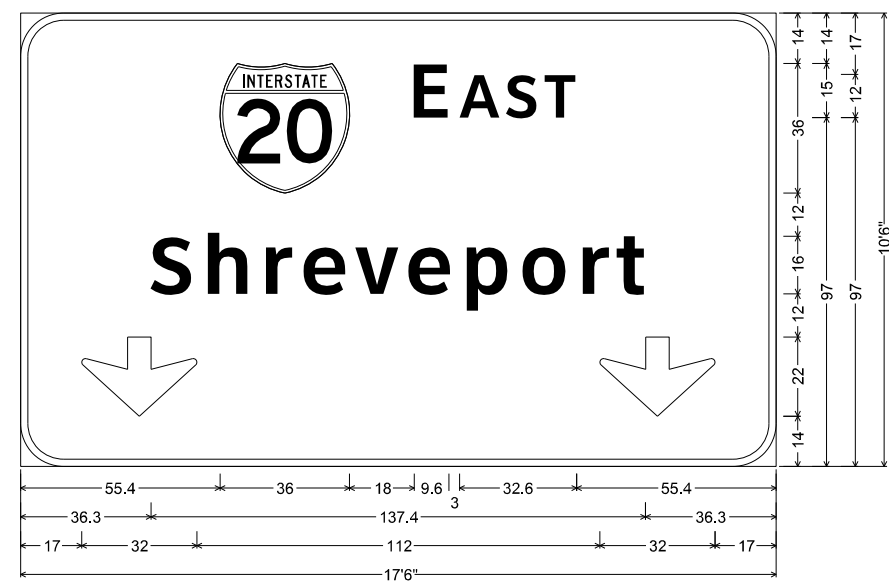

12.0" Radius, 2.0" Border, White on Green;
 Interstate 20 M1-1; "E AST", ClearviewHwy-5-W-R; "Shreveport", ClearviewHwy-5-W-R;
 Down Arrow 22 - 22.0" 270°; Down Arrow 22 - 22.0" 270°;

SHEET 47 SIGN 7
SHEET 48 SIGN 8
SHEET 84 SIGN 6

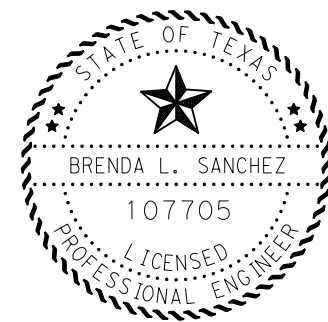

Brenda L Sanchez, P.E. 03/20/23
 Signature of Registrant & Date

 © 2023			
GUIDE SIGN DETAILS			
SCALE: NTS		SHEET 25 OF 47	
DESIGN/CK BLS	FED. RD. DIV. NO. 6	STATE PROJECT NO. (SEE TITLE SHEET)	
CHECK BLS	STATE TEXAS	DISTRICT DAL	HIGHWAY NO. IH 20
CHECK MA	CONTROL 0095	COUNTY VARIOUS	SHEET NO. 250
CHECK BA	SECTION 14	JOB 033, ETC	

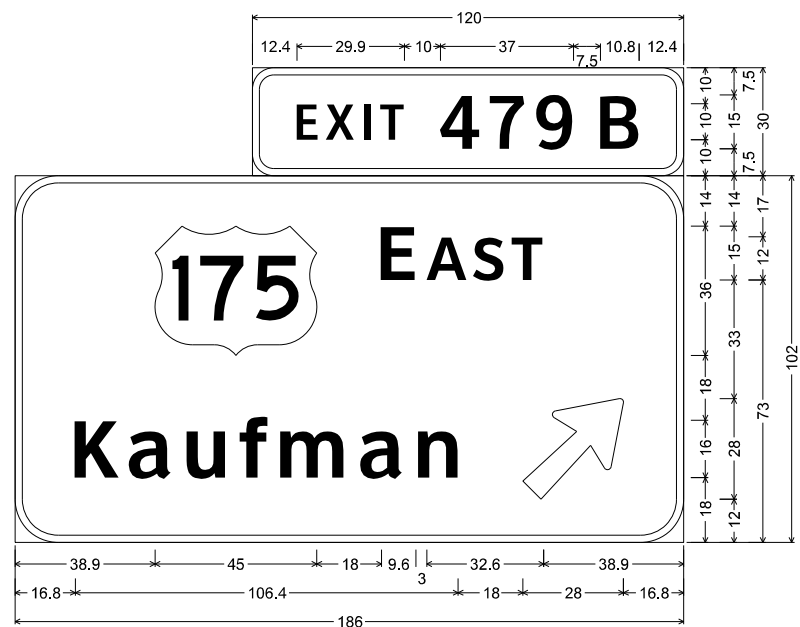

6.0" Radius, 2.0" Border, White on Green;
 "EXIT", ClearviewHwy-4-W; "479 B", ClearviewHwy-4-W;

12.0" Radius, 2.0" Border, White on Green;
 US 175 M1-4; "E AST", ClearviewHwy-5-W-R; "Kaufman", ClearviewHwy-5-W-R;
 Arrow A-3 - 35.8" 45";

SHEET 47 SIGN 9

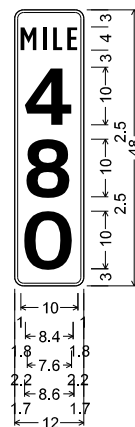

D10-3 10in;
 1.5" Radius, 0.5" Border, White on Green;
 "MILE", ClearviewHwy-2-W;
 "4", ClearviewHwy-6-W;
 "8", ClearviewHwy-6-W;
 "0", ClearviewHwy-6-W;

SHEET 48 SIGN 4

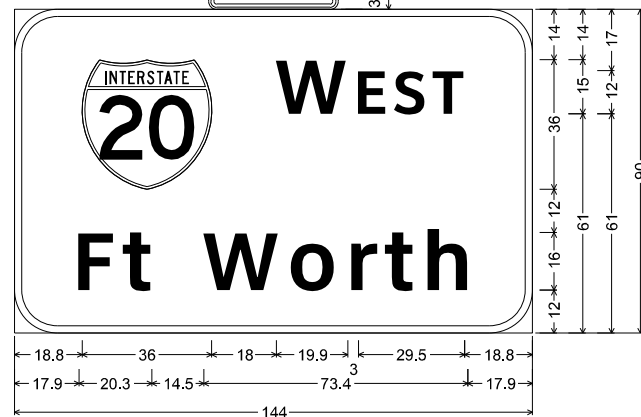
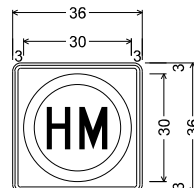

R14-2_36x36;
 2.3" Radius, 0.9" Border, 0.6" Indent, Black on White;
 12.0" Radius, 2.0" Border, White on Green;
 Interstate 20 M1-1; "W EST", ClearviewHwy-5-W-R;
 "Ft Worth", ClearviewHwy-5-W-R;

SHEET 48 SIGN 5
 SHEET 112 SIGN 5

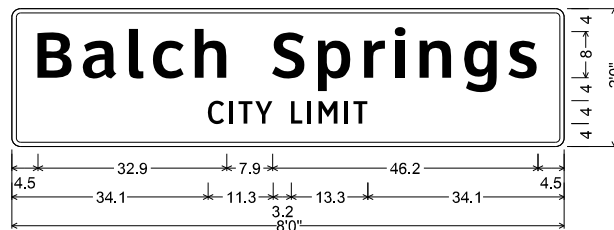

I-2aT 8in;
 1.5" Radius, 0.8" Border, White on Green;
 "Balch Springs", ClearviewHwy-5-W-R;
 "CITY LIMIT", ClearviewHwy-3-W;

SHEET 47 SIGN 10
 SHEET 54 SIGN 4
 SHEET 117 SIGN 1



6.0" Radius, 2.0" Border, White on Green;
 "EXIT 479 A", ClearviewHwy-4-W;
 12.0" Radius, 2.0" Border, White on Green;
 US 175 M1-4; "W EST", ClearviewHwy-5-W-R;
 "Dallas", ClearviewHwy-5-W-R; "1/4 MILE", ClearviewHwy-5-W-R;

SHEET 48 SIGN 2



6.0" Radius, 2.0" Border, White on Green;
 "EXIT", ClearviewHwy-4-W; "479", ClearviewHwy-4-W;
 "A", ClearviewHwy-4-W;
 12.0" Radius, 2.0" Border, White on Green;
 US 175 M1-4; "W EST", ClearviewHwy-5-W-R;
 "Dallas", ClearviewHwy-5-W-R; "1/2 MILE", ClearviewHwy-5-W-R;

SHEET 48 SIGN 6

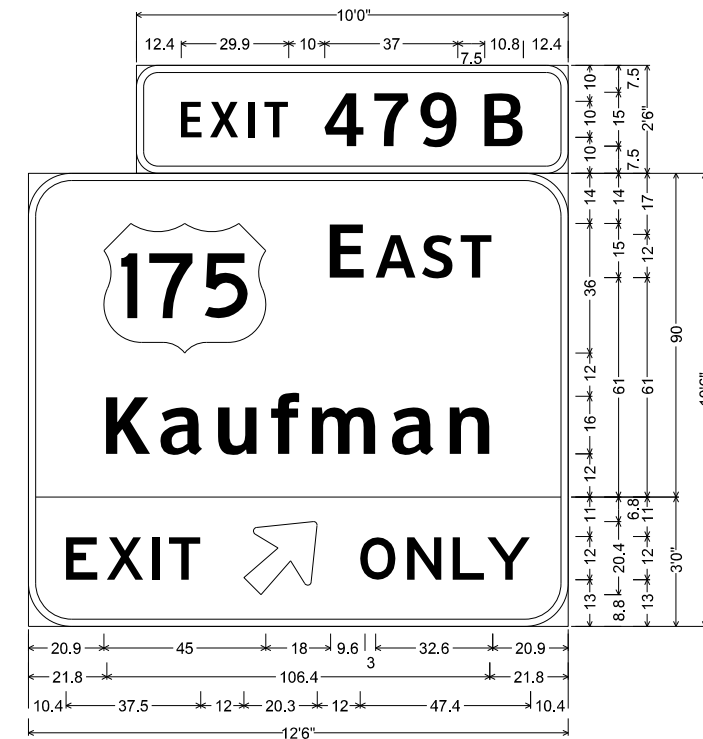

6.0" Radius, 2.0" Border, White on Green;
 "EXIT 479 B", ClearviewHwy-4-W;
 12.0" Radius, 2.0" Border, White on Green;
 US 175 M1-4; "E AST", ClearviewHwy-5-W-R;
 "Kaufman", ClearviewHwy-5-W-R;
 12.0" Radius, 2.0" Border, Black on Yellow;
 "EXIT", E; Arrow B-3 - 25.0" 45"; "ONLY", E;

SHEET 48 SIGN 3

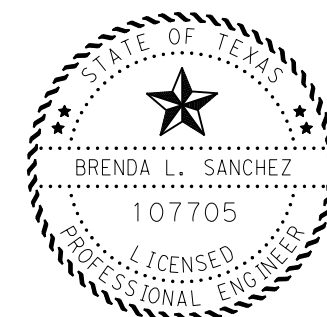

Brenda L Sanchez, P.E. 03/20/23
 Signature of Registrar & Date



GUIDE SIGN DETAILS

SCALE: NTS			SHEET 26 OF 47	
DESIGN/CK BLS	FED. RD. DIV. NO. 6	STATE PROJECT NO. (SEE TITLE SHEET)		HIGHWAY NO. IH 20
CHECK BLS	STATE	DISTRICT DAL	COUNTY VARIOUS	SHEET NO. 251
CHECK MA	TEXAS	SECTION CONTROL	JOB 033, ETC	
CHECK BA	0095	14		

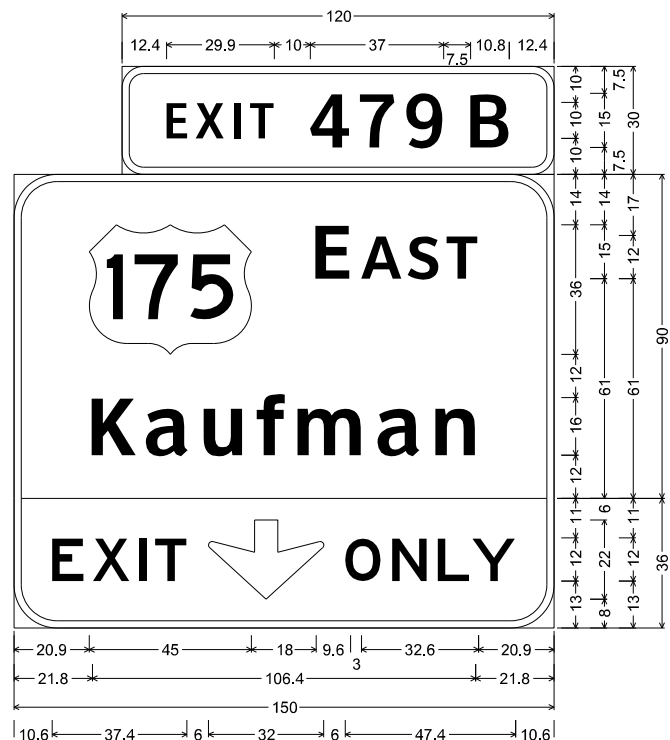

6.0" Radius, 2.0" Border, White on Green;
 "EXIT 479 B", ClearviewHwy-4-W;

12.0" Radius, 2.0" Border, White on Green;
 US 175 M1-4; "E AST", ClearviewHwy-5-W-R;
 "Kaufman", ClearviewHwy-5-W-R;

12.0" Radius, 2.0" Border, Black on Yellow;
 "EXIT", E; Down Arrow 22 - 22.0" 270"; "ONLY", E;

SHEET 48 SIGN 7
 SHEET 112 SIGN 6

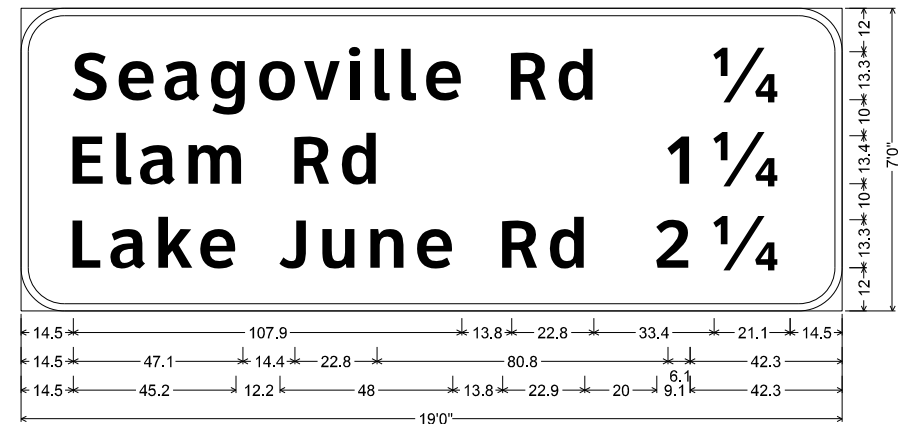

12.0" Radius, 2.0" Border, White on Green;
 "Seagoville Rd", ClearviewHwy-5-W-R; "1/4", ClearviewHwy-5-W-R; "Elam Rd", ClearviewHwy-5-W-R;
 "1 1/4", ClearviewHwy-5-W-R; "Lake June Rd", ClearviewHwy-5-W-R; "2 1/4", ClearviewHwy-5-W-R;

SHEET 48 SIGN 12

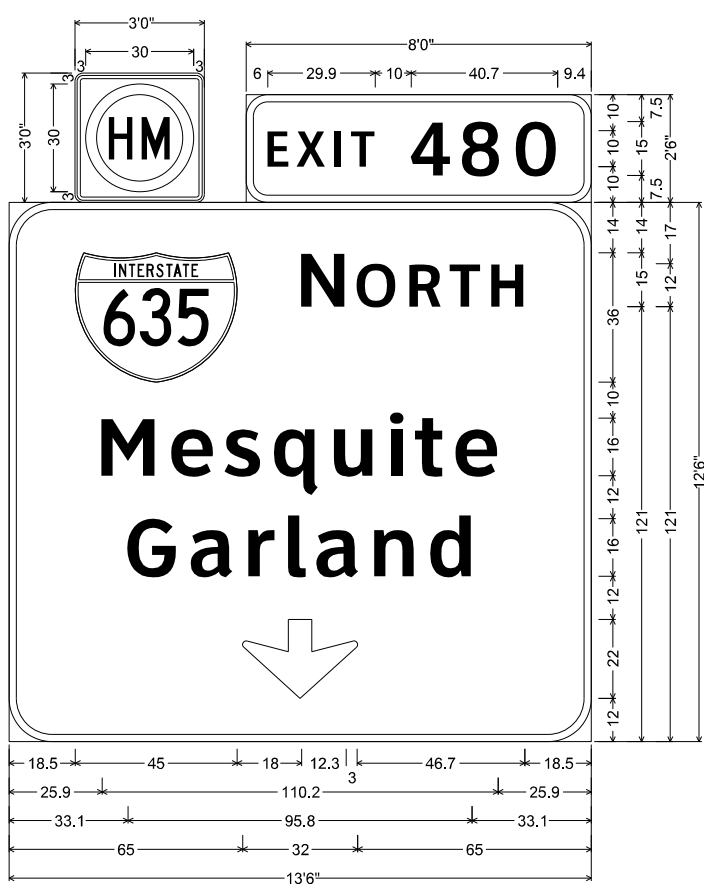

R14-2_36x36;
 2.3" Radius, 0.9" Border, 0.6" Indent, Black on White;

6.0" Radius, 2.0" Border, White on Green;
 "EXIT", ClearviewHwy-4-W; "480", ClearviewHwy-4-W;

12.0" Radius, 2.0" Border, White on Green;
 Interstate 635 M1-1 16.0" C; "N ORTH", ClearviewHwy-5-W-R;
 "Mesquite", ClearviewHwy-5-W-R; "Garland", ClearviewHwy-5-W-R;
 Down Arrow 22 - 22.0" 270";

SHEET 48 SIGN 10

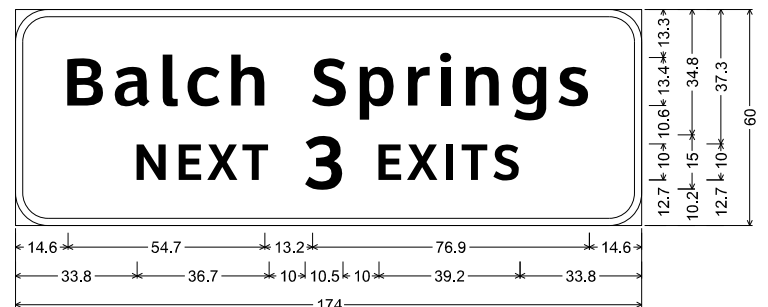

9.0" Radius, 2.0" Border, White on Green;
 "Balch Springs", ClearviewHwy-5-W-R; "NEXT", ClearviewHwy-5-W-R;
 "3", ClearviewHwy-5-W-R; "EXITS", ClearviewHwy-5-W-R;

SHEET 48 SIGN 13

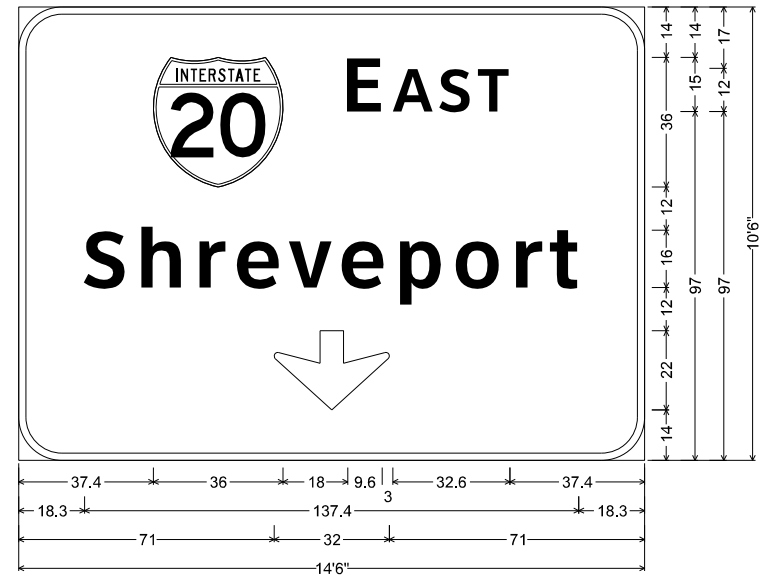

12.0" Radius, 2.0" Border, White on Green;
 Interstate 20 M1-1; "E AST", ClearviewHwy-5-W-R;
 "Shreveport", ClearviewHwy-5-W-R; Down Arrow 22 - 22.0" 270";

SHEET 48 SIGN 11

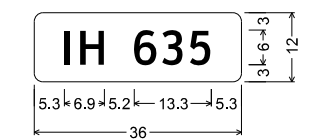

D3-1G(1) 6in;
 1.5" Radius, No border, White on Green;
 "IH 635", ClearviewHwy-3-W;

SHEET 48 SIGN 14
 SHEET 49 SIGN 1

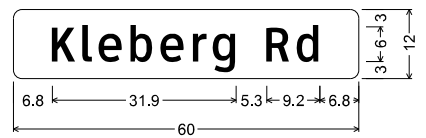

D3-1G(1) 6in;
 1.5" Radius, No border, White on Green;
 "Kleberg Rd", ClearviewHwy-3-W;

SHEET 49 SIGN 3
 SHEET 49 SIGN 9

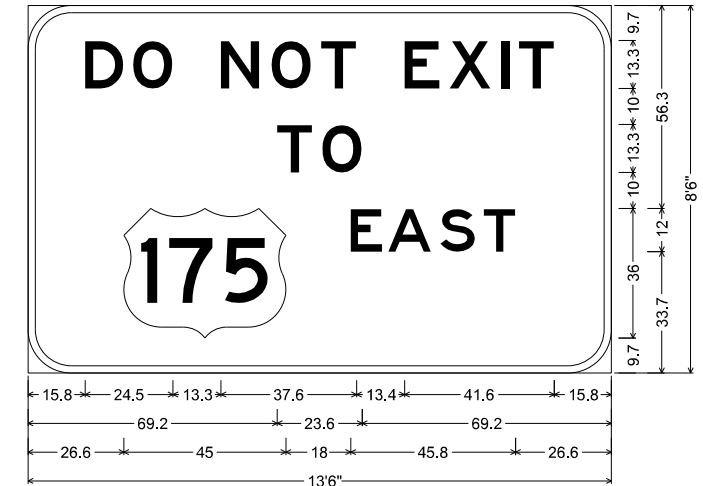

12.0" Radius, 2.0" Border, Black on White;
 "DO NOT EXIT", E; "TO", E; US 175 M1-4; "EAST", E;

SHEET 49 SIGN 2

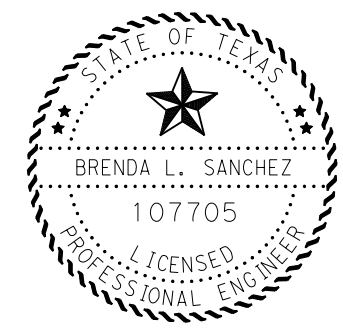

Brenda L Sanchez, P.E. 03/20/23
 Signature of Registrar & Date

			
GUIDE SIGN DETAILS			
SCALE: NTS		SHEET 27 OF 47	
DESIGN/CK BLS	FED. RD. DIV. NO. 6	STATE PROJECT NO. (SEE TITLE SHEET)	HIGHWAY NO. IH 20
CHECK BLS	STATE	DISTRICT	COUNTY
CHECK MA	TEXAS	DAL	VARIOUS
CHECK BA	CONTROL	SECTION	JOB
			252
	0095	14	033, ETC

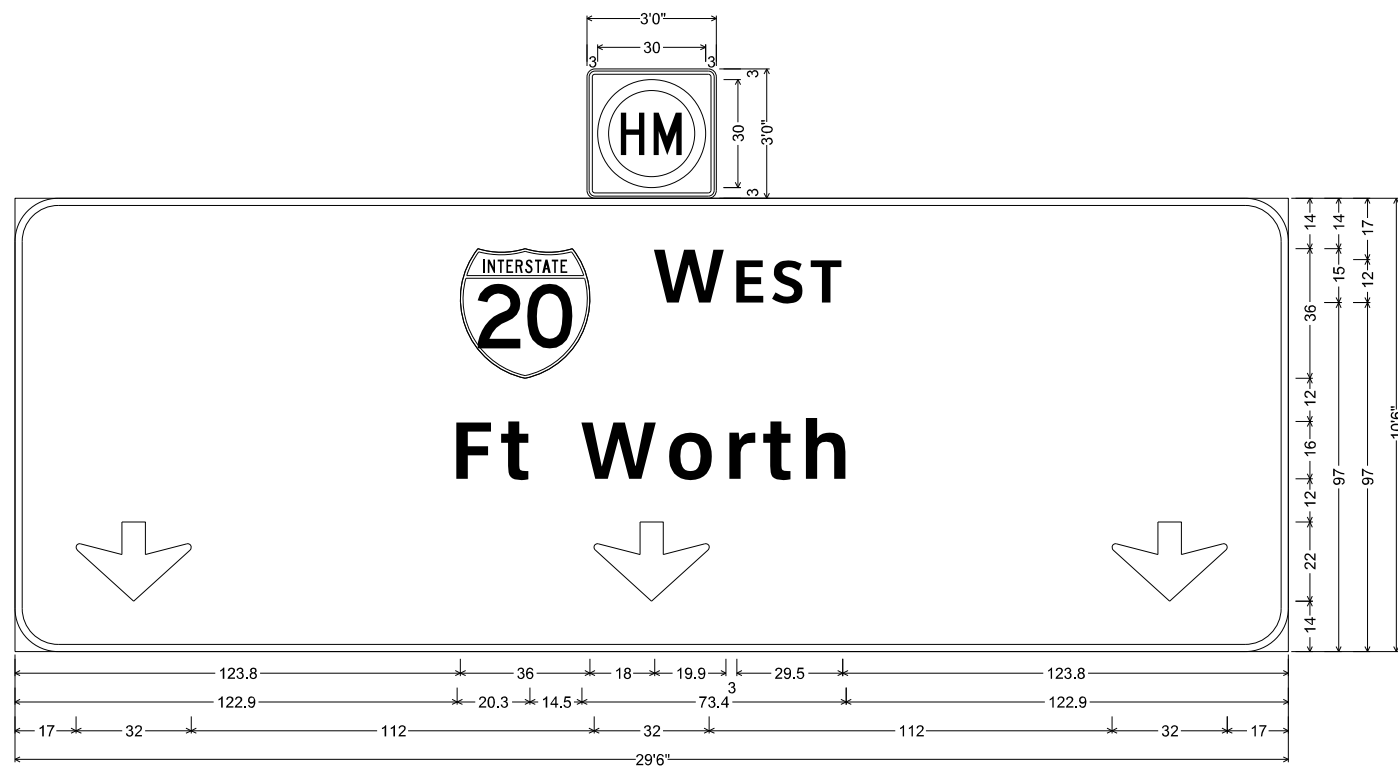

R14-2_36x36;
2.3" Radius, 0.9" Border, 0.6" Indent, Black on White;

12.0" Radius, 2.0" Border, White on Green;
Interstate 20 M1-1; "W EST", ClearviewHwy-5-W-R; "Ft Worth", ClearviewHwy-5-W-R; Down Arrow 22 - 22.0" 270°; Down Arrow 22 - 22.0" 270°;
Down Arrow 22 - 22.0" 270°;

SHEET 49 SIGN 5

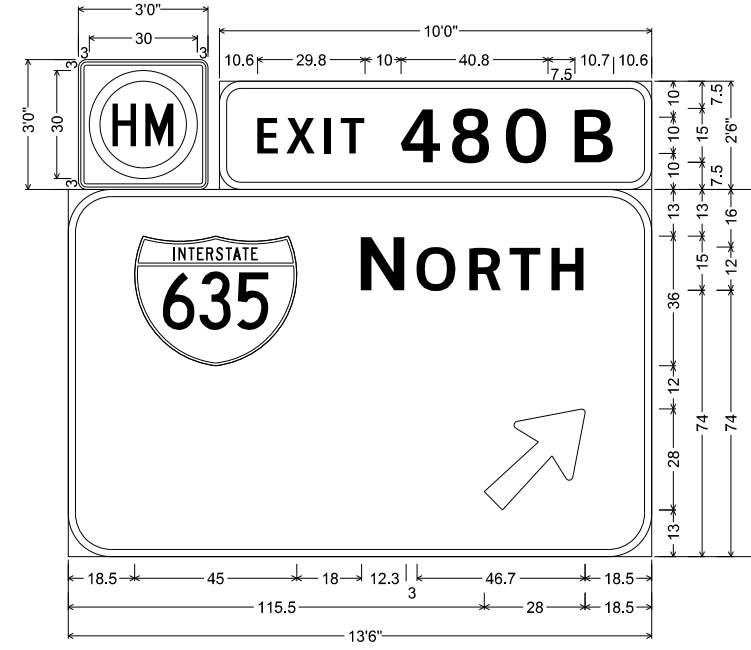

R14-2_36x36;
2.3" Radius, 0.9" Border, 0.6" Indent, Black on White;

6.0" Radius, 2.0" Border, White on Green;
"EXIT 480 B", ClearviewHwy-4-W;

12.0" Radius, 2.0" Border, White on Green;
Interstate 635 M1-1 16.0" C; "N ORTH", ClearviewHwy-5-W-R;
Arrow A-3 - 35.6" 45°;

SHEET 49 SIGN 6

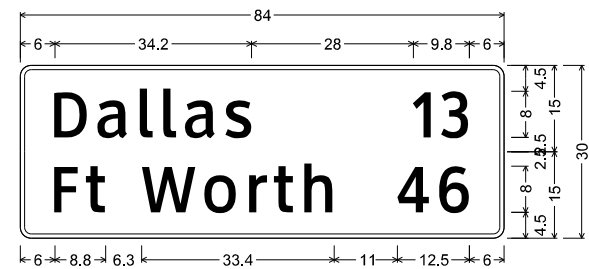

D2-2 8in;

1.9" Radius, 0.8" Border, White on Green;
"Dallas", ClearviewHwy-3-W; "13", ClearviewHwy-3-W;

1.9" Radius, 0.8" Border, White on Green;
"Ft Worth", ClearviewHwy-3-W; "46", ClearviewHwy-3-W;

SHEET 49 SIGN 7

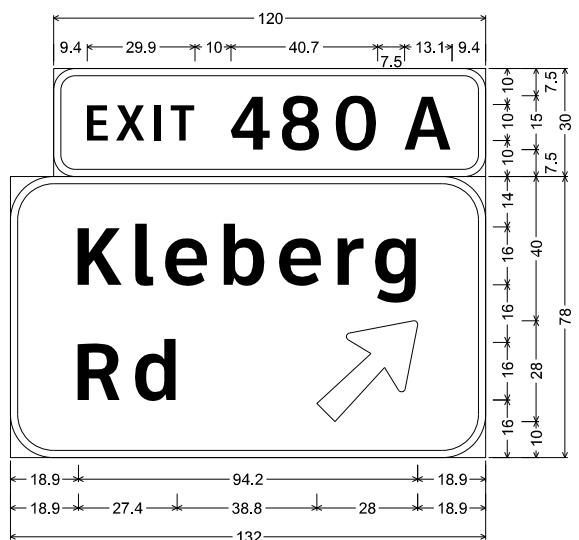

6.0" Radius, 2.0" Border, White on Green;
"EXIT 480 A", ClearviewHwy-4-W;

12.0" Radius, 2.0" Border, White on Green;
"Kleberg", ClearviewHwy-5-W-R; "Rd", ClearviewHwy-5-W-R;
Arrow A-3 - 35.6" 45°;

SHEET 50 SIGN 1

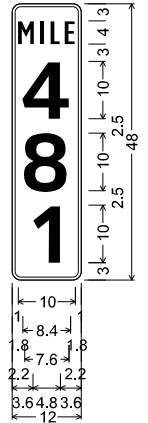

D10-3 10in;
1.5" Radius, 0.5" Border, White on Green;
"MILE", ClearviewHwy-2-W;

"4", ClearviewHwy-6-W;
"8", ClearviewHwy-6-W;
"1", ClearviewHwy-6-W;

SHEET 50 SIGN 2
SHEET 50 SIGN 3

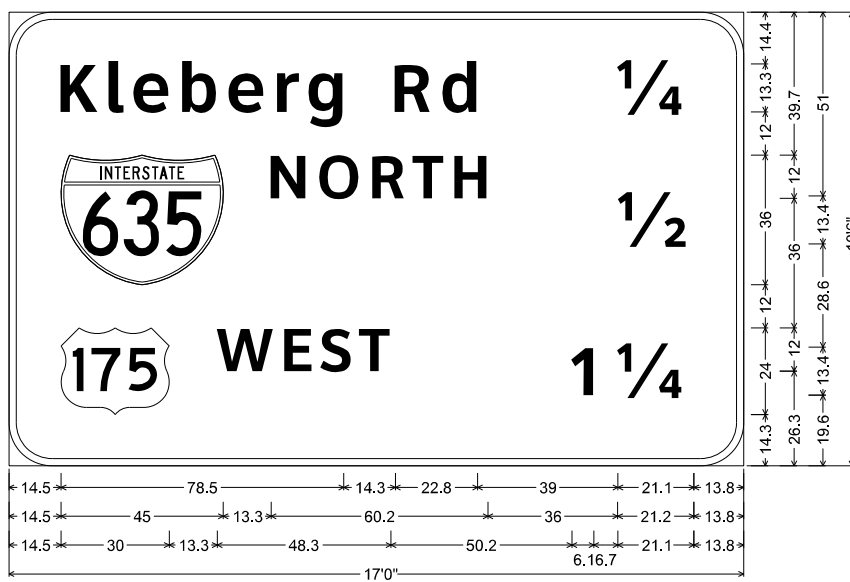

12.0" Radius, 2.0" Border, White on Green;

"Kleberg Rd", ClearviewHwy-5-W-R; "1/4", ClearviewHwy-5-W-R; Interstate 635 M1-1 18.0" C;
"NORTH", ClearviewHwy-5-W-R; "1/2", ClearviewHwy-5-W-R; US 175 M1-4;
"WEST", ClearviewHwy-5-W-R; "1 1/4", ClearviewHwy-5-W-R;

SHEET 50 SIGN 4

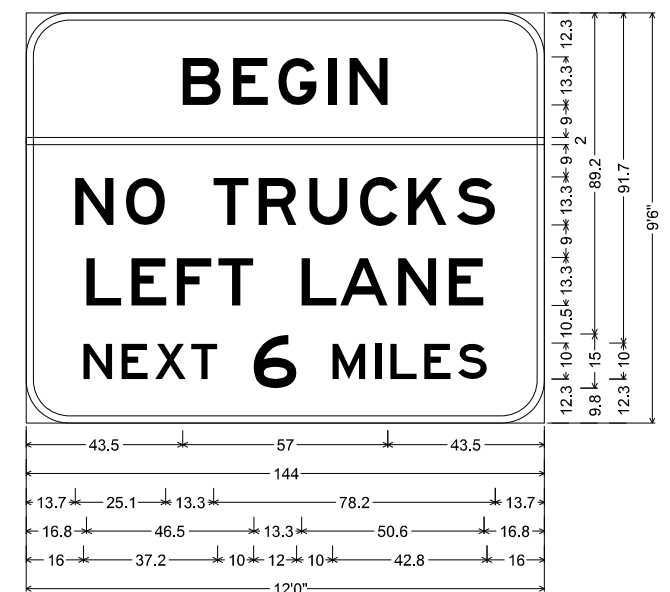

12.0" Radius, 2.0" Border, Black on White;
"BEGIN", E; "NO TRUCKS", E; "LEFT LANE", E;
"NEXT 6 MILES", E;

SHEET 50 SIGN 5

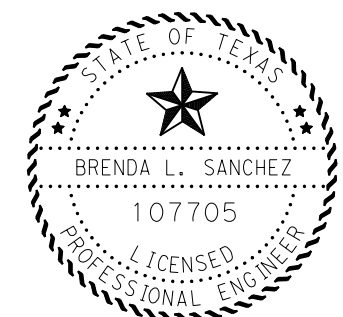

Brenda L Sanchez, P.E. 03/20/23
Signature of Registrant & Date

 Texas Department of Transportation © 2023			
GUIDE SIGN DETAILS			
SCALE: NTS		SHEET 28 OF 47	
DESIGN/CK BLS	FED. RD. DIV. NO. 6	STATE PROJECT NO. (SEE TITLE SHEET)	HIGHWAY NO. IH 20
CHECK BLS	STATE	DISTRICT	COUNTY
CHECK MA	TEXAS	DAL	VARIOUS
CHECK BA	CONTROL	SECTION	JOB
	0095	14	033, ETC
			253

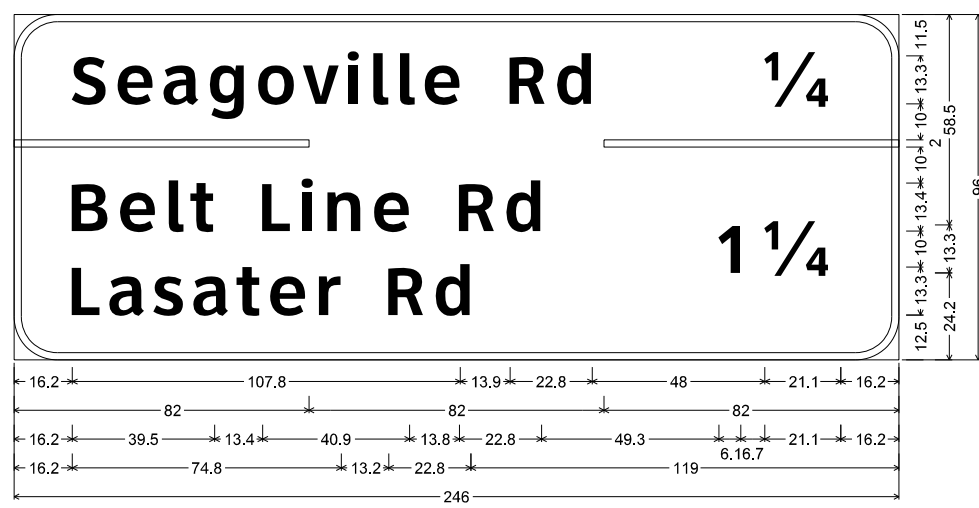

12.0" Radius, 2.0" Border, White on Green;
 "Seagoville Rd", ClearviewHwy-5-W-R; "1/4", ClearviewHwy-5-W-R; "Belt Line Rd", ClearviewHwy-5-W-R;
 "Lasater Rd", ClearviewHwy-5-W-R; "1 1/4", ClearviewHwy-5-W-R;

SHEET 50 SIGN 6

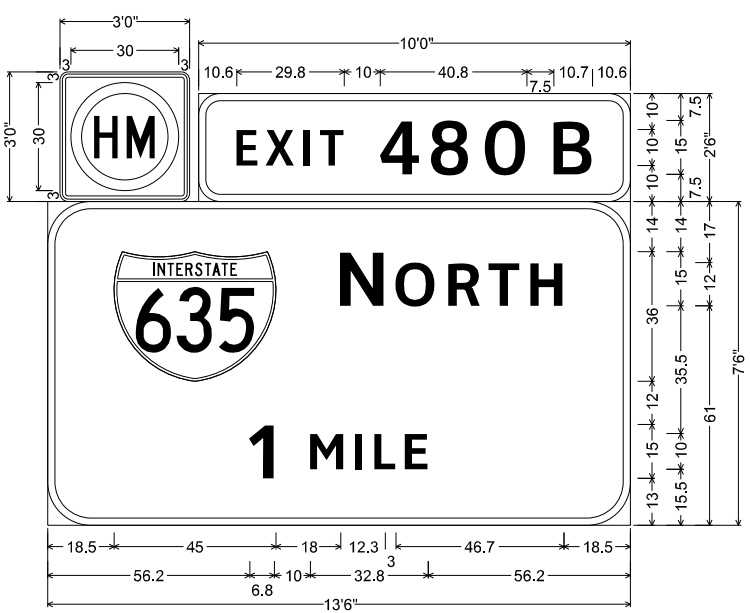

R14-2_36x36;
 2.3" Radius, 0.9" Border, 0.6" Indent, Black on White;
 6.0" Radius, 2.0" Border, White on Green;
 "EXIT 480 B", ClearviewHwy-4-W;
 12.0" Radius, 2.0" Border, White on Green;
 Interstate 635 M1-1 18.0" C; "N ORTH", ClearviewHwy-5-W-R;
 "1", ClearviewHwy-5-W-R; "MILE", ClearviewHwy-5-W-R;

SHEET 51 SIGN 2

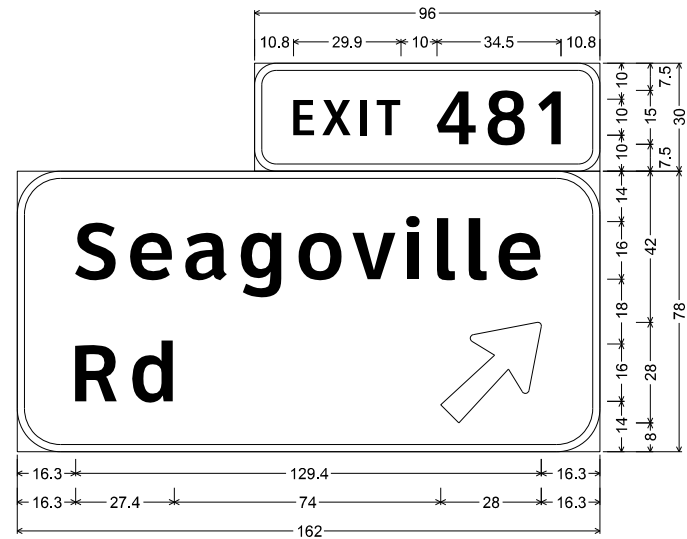

6.0" Radius, 2.0" Border, White on Green;
 "EXIT 481", ClearviewHwy-4-W;
 12.0" Radius, 2.0" Border, White on Green;
 "Seagoville", ClearviewHwy-5-W-R; "Rd", ClearviewHwy-5-W-R;
 Arrow A-3 - 35.6" 45";

SHEET 50 SIGN 7
SHEET 51 SIGN 4

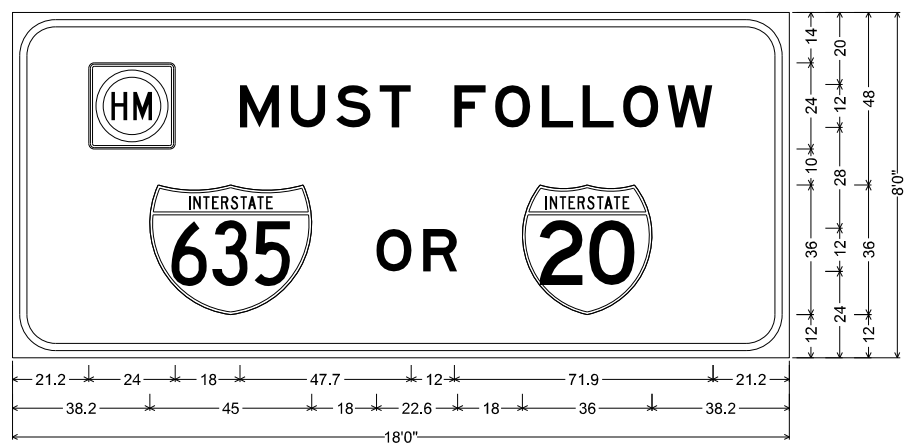

R14-6T;
 12.0" Radius, 2.0" Border, 2.0" Indent, Black on White;
 "MUST FOLLOW", E; Interstate 635 M1-1 18.0" C; "OR", E; Interstate 20 M1-1 18.0" D;

SHEET 51 SIGN 5

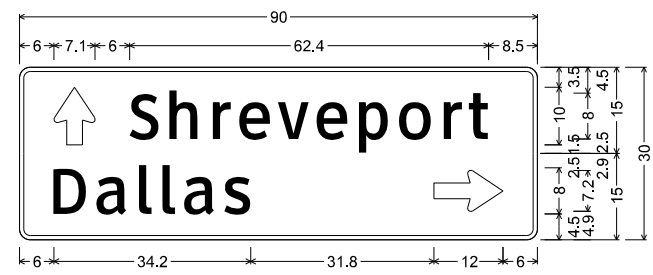

D1-2 8in UP-RT;
 1.9" Radius, 0.8" Border, White on Green;
 Standard Arrow Custom 10.0" X 7.1" 90°;
 "Shreveport", ClearviewHwy-3-W;
 1.9" Radius, 0.8" Border, White on Green;
 "Dallas", ClearviewHwy-3-W;
 Standard Arrow Custom 12.0" X 7.1" 0°;

- SHEET 51 SIGN 1
- SHEET 62 SIGN 1
- SHEET 68 SIGN 2
- SHEET 69 SIGN 3
- SHEET 70 SIGN 1
- SHEET 73 SIGN 1
- SHEET 82 SIGN 3
- SHEET 85 SIGN 2
- SHEET 97 SIGN 1

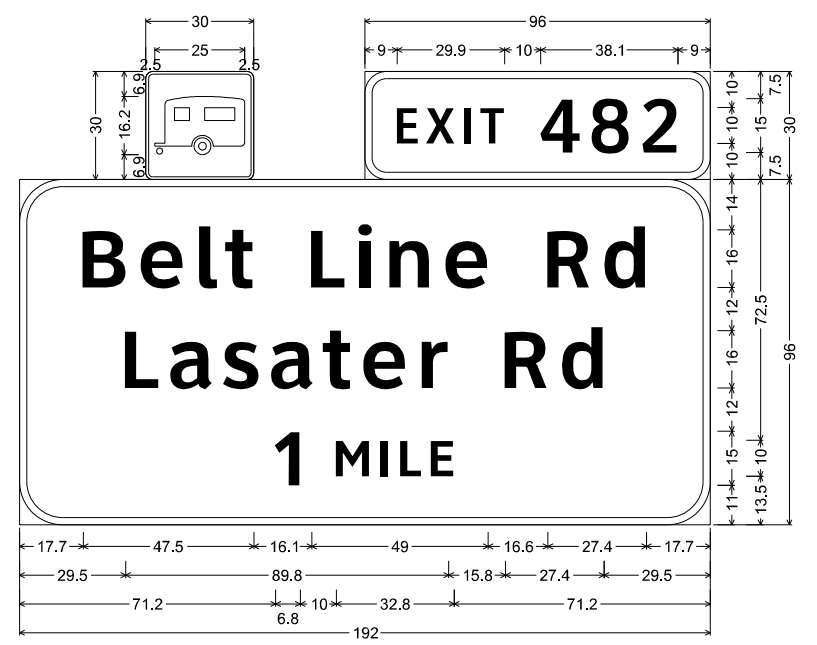

6.0" Radius, 2.0" Border, White on Green;
 "EXIT", ClearviewHwy-4-W; "482", ClearviewHwy-4-W;
 12.0" Radius, 2.0" Border, White on Green;
 "Belt Line Rd", ClearviewHwy-5-W-R; "Lasater Rd", ClearviewHwy-5-W-R;
 "1", ClearviewHwy-5-W-R; "MILE", ClearviewHwy-5-W-R;

SHEET 51 SIGN 6

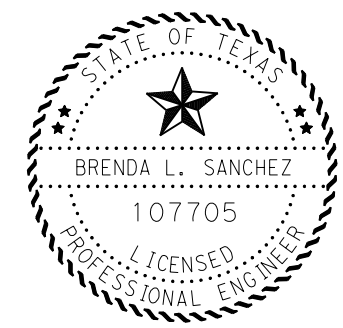

Brenda L Sanchez, P.E. 03/20/23
 Signature of Registrar & Date

 ©2023			
GUIDE SIGN DETAILS			
SCALE: NTS		SHEET 29 OF 47	
DESIGN/CK BLS	FED. RD. DIV. NO. 6	STATE PROJECT NO. (SEE TITLE SHEET)	
CHECK BLS	STATE	DISTRICT DAL	COUNTY VARIOUS
CHECK MA	TEXAS	SECTION	JOB
CHECK BA	0095	14	033, ETC
			254

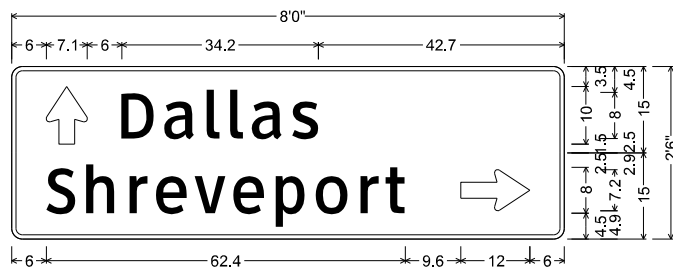

D1-2 8in UP-RT;

1.9" Radius, 0.8" Border, White on Green;
Standard Arrow Custom 10.0" X 7.1" 90°;
"Dallas", ClearviewHwy-3-W;

1.9" Radius, 0.8" Border, White on Green;
"Shreveport", ClearviewHwy-3-W;
Standard Arrow Custom 12.0" X 7.1" 0°;

- SHEET 51 SIGN 7
- SHEET 62 SIGN 7
- SHEET 82 SIGN 8
- SHEET 85 SIGN 9
- SHEET 88 SIGN 11
- SHEET 97 SIGN 6

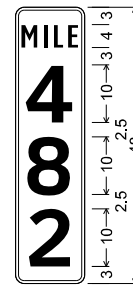

D10-3 10in;

1.5" Radius, 0.5" Border, White on Green;
"MILE", ClearviewHwy-2-W;

"4", ClearviewHwy-6-W;
"8", ClearviewHwy-6-W;
"2", ClearviewHwy-6-W;

- SHEET 52 SIGN 1
- SHEET 52 SIGN 2

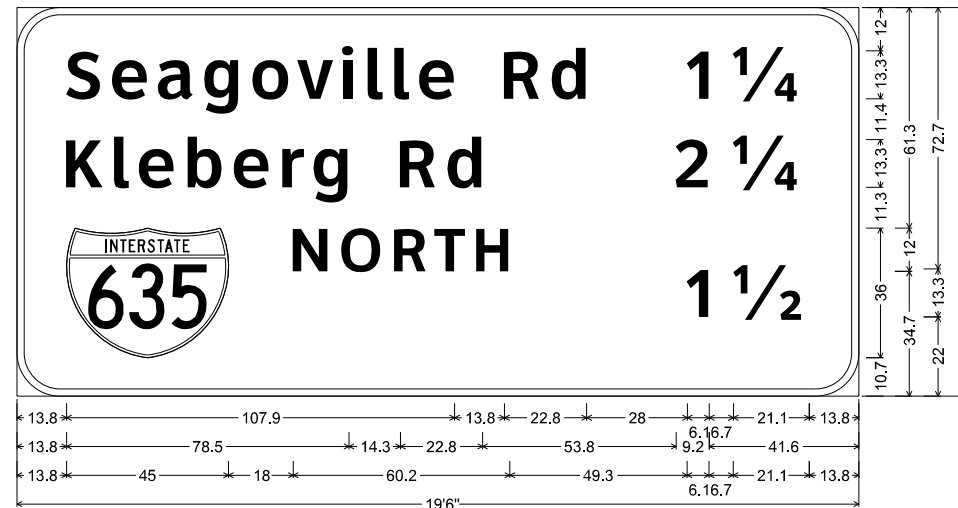

12.0" Radius, 2.0" Border, White on Green;
"Seagoville Rd", ClearviewHwy-5-W-R; "1 1/4", ClearviewHwy-5-W-R; "Kleberg Rd", ClearviewHwy-5-W-R;
"2 1/4", ClearviewHwy-5-W-R; Interstate 635 M1-1 18.0" C; "NORTH", ClearviewHwy-5-W-R;
"1 1/2", ClearviewHwy-5-W-R;

- SHEET 52 SIGN 3

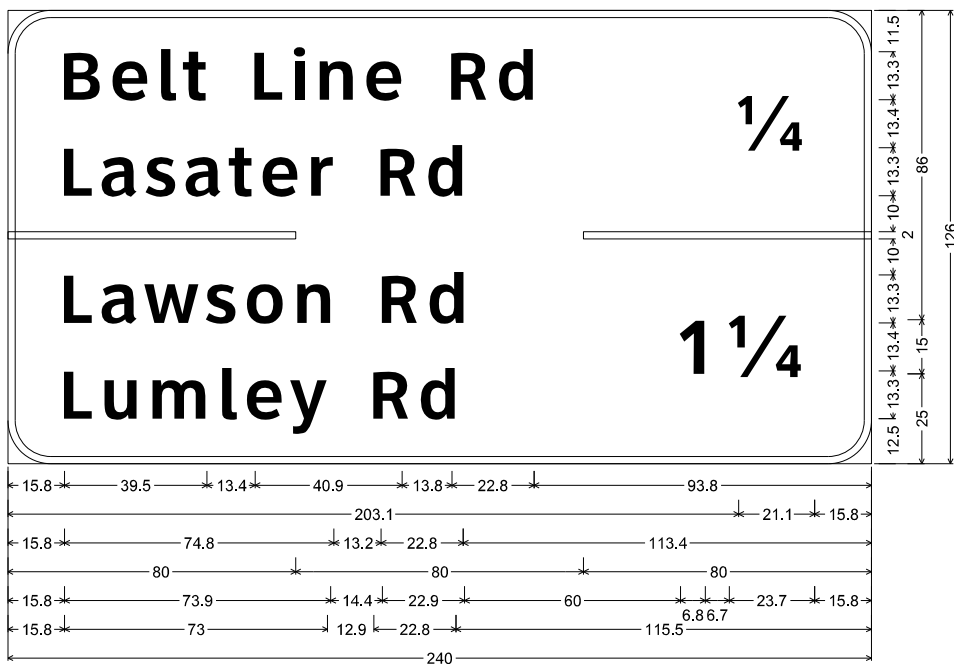

12.0" Radius, 2.0" Border, White on Green;
"Belt Line Rd", ClearviewHwy-5-W-R; "1/4", ClearviewHwy-5-W-R; "Lasater Rd", ClearviewHwy-5-W-R;
"Lawson Rd", ClearviewHwy-5-W-R; "Lumley Rd", ClearviewHwy-5-W-R; "1 1/4", ClearviewHwy-5-W-R;

SHEET 52 SIGN 4

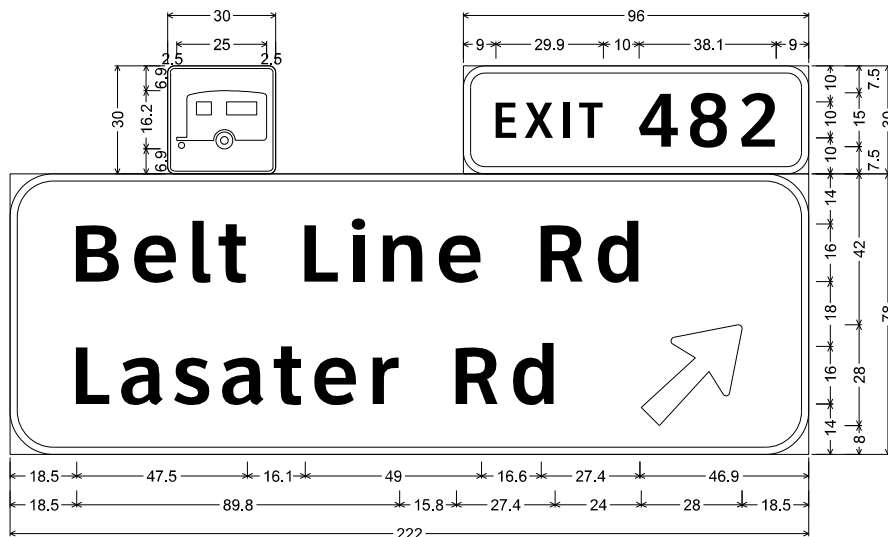

6.0" Radius, 2.0" Border, White on Green;
"EXIT 482", ClearviewHwy-4-W;

12.0" Radius, 2.0" Border, White on Green;
"Belt Line Rd", ClearviewHwy-5-W-R; "Lasater Rd", ClearviewHwy-5-W-R; Arrow A-3 - 35.6" 45°;

SHEET 52 SIGN 5

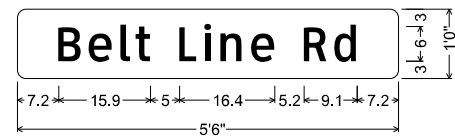

D3-1G(1) 6in;
1.5" Radius, No border, White on Green;
"Belt Line Rd", ClearviewHwy-3-W;

- SHEET 53 SIGN 1
- SHEET 53 SIGN 7

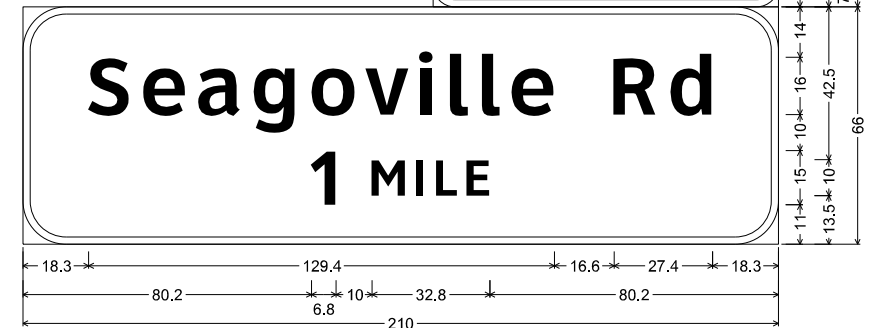
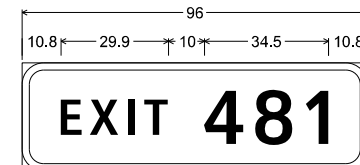

6.0" Radius, 2.0" Border, White on Green;
"EXIT 481", ClearviewHwy-4-W;

12.0" Radius, 2.0" Border, White on Green;
"Seagoville Rd", ClearviewHwy-5-W-R; "1", ClearviewHwy-5-W-R; "MILE", ClearviewHwy-5-W-R;

SHEET 53 SIGN 2

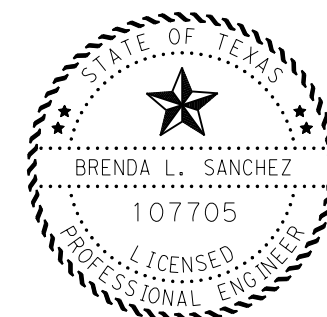

Brenda L Sanchez, P.E. 03/20/23
Signature of Registrar & Date



GUIDE SIGN DETAILS

SCALE: NTS SHEET 30 OF 47

DESIGN/CK	FED. RD. DIV. NO.	STATE PROJECT NO.		HIGHWAY NO.
BLS	6	(SEE TITLE SHEET)		IH 20
BLS	STATE	DISTRICT	COUNTY	SHEET NO.
MA	TEXAS	DAL	VARIOUS	255
CK	CONTROL	SECTION	JOB	
BA	0095	14	033, ETC	

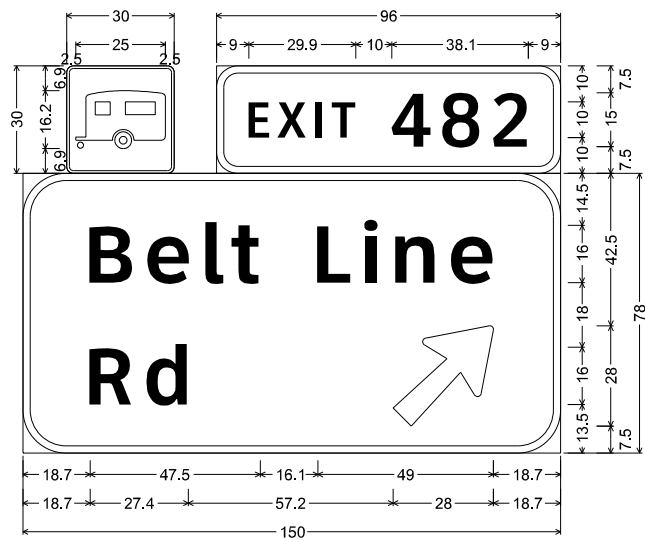

D9-3a_30x30; 1.9\"/>
6.0\" Radius, 2.0\" Border, White on Green; "EXIT 482", ClearviewHwy-4-W; 12.0\" Radius, 2.0\" Border, White on Green; "Belt Line", ClearviewHwy-5-W-R; "Rd", ClearviewHwy-5-W-R; Arrow A-3 - 35.6\" 45\";

SHEET 53 SIGN 4

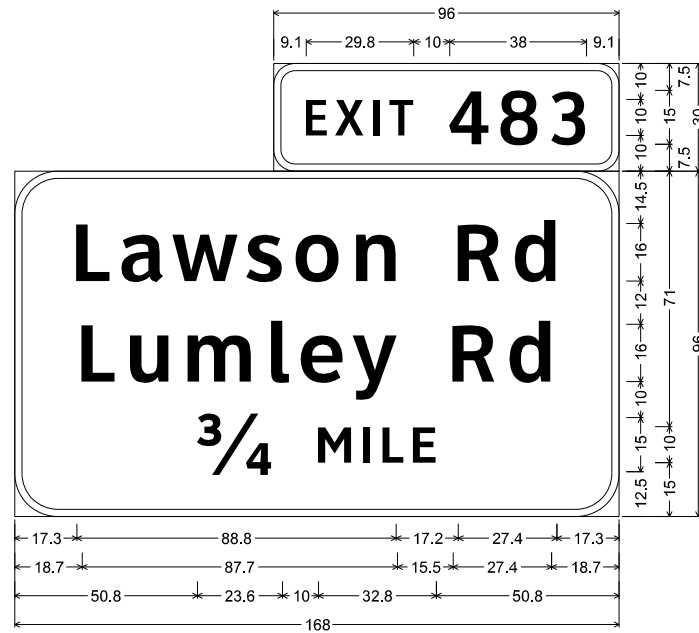

6.0\"/>
12.0\" Radius, 2.0\" Border, White on Green; "Lawson Rd", ClearviewHwy-5-W-R; "Lumley Rd", ClearviewHwy-5-W-R; "3/4", ClearviewHwy-5-W-R; "MILE", ClearviewHwy-5-W-R;

SHEET 53 SIGN 5

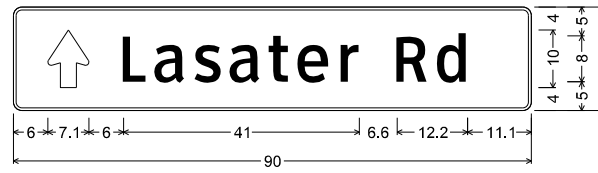

D1-1 8in UP; 1.5\"/>
SHEET 53 SIGN 6
SHEET 55 SIGN 2

SHEET 54 SIGN 6

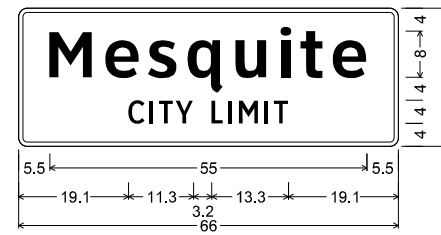

L-2aT 8in; 1.5\"/>
SHEET 67 SIGN 3
SHEET 117 SIGN 6

SHEET 54 SIGN 2

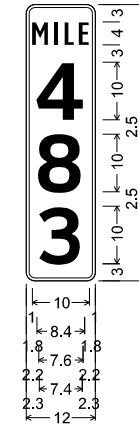

D10-3 10in; 1.5\"/>
SHEET 54 SIGN 1
SHEET 54 SIGN 2

SHEET 54 SIGN 1

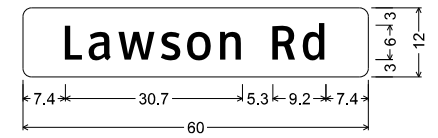

D3-1G(1) 6in; 1.5\"/>
SHEET 55 SIGN 8

SHEET 55 SIGN 8

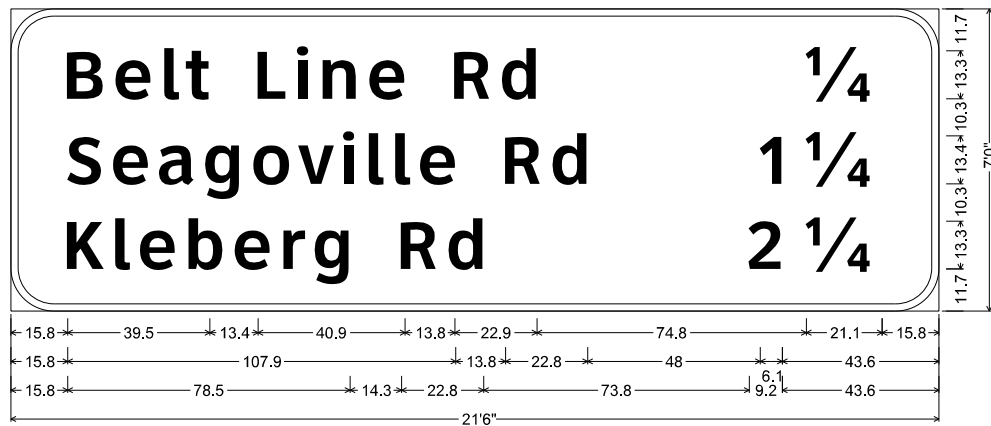

12.0\"/>
"Belt Line Rd", ClearviewHwy-5-W-R; "1/4", ClearviewHwy-5-W-R; "Seagoville Rd", ClearviewHwy-5-W-R; "1 1/4", ClearviewHwy-5-W-R; "Kleberg Rd", ClearviewHwy-5-W-R; "2 1/4", ClearviewHwy-5-W-R;

SHEET 54 SIGN 3

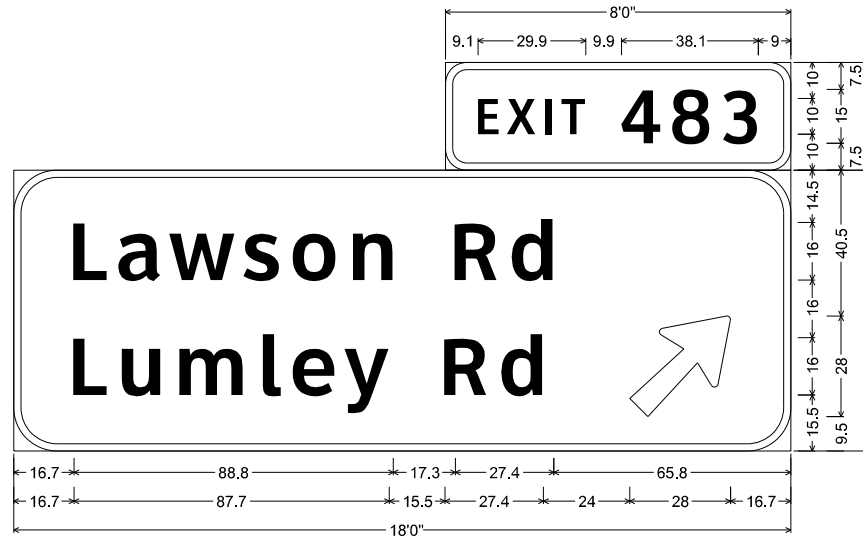

6.0\"/>
12.0\" Radius, 2.0\" Border, White on Green; "Lawson Rd", ClearviewHwy-5-W-R; "Lumley Rd", ClearviewHwy-5-W-R; Arrow A-3 - 35.6\" 45\";

SHEET 54 SIGN 7

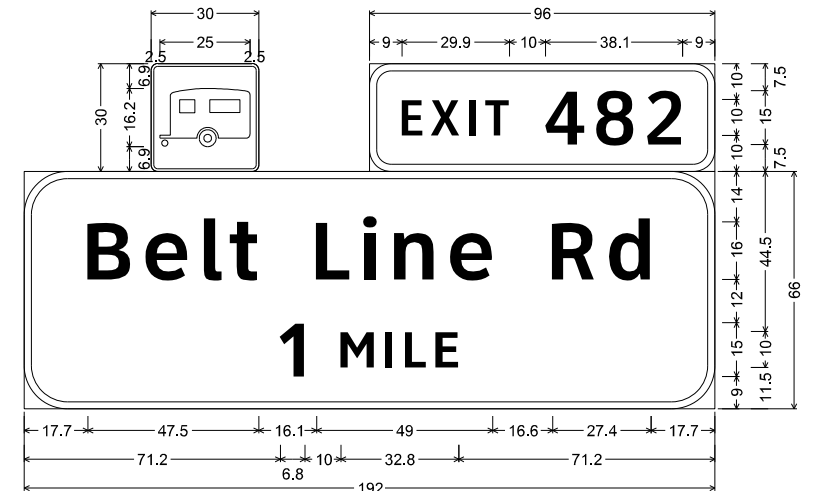

D9-3a_30x30; 1.9\"/>
6.0\" Radius, 2.0\" Border, White on Green; "EXIT 482", ClearviewHwy-4-W; 12.0\" Radius, 2.0\" Border, White on Green; "Belt Line Rd", ClearviewHwy-5-W-R; "1", ClearviewHwy-5-W-R; "MILE", ClearviewHwy-5-W-R;

SHEET 55 SIGN 4

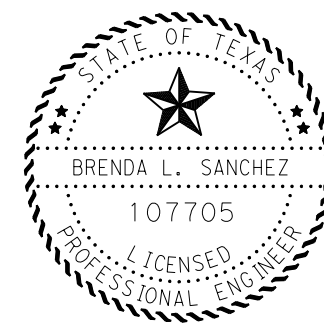

Brenda L Sanchez, P.E. 03/20/23
Signature of Registrant & Date



GUIDE SIGN DETAILS

SCALE: NTS SHEET 31 OF 47

DESIGN/CK	FED. RD. DIV. NO.	STATE PROJECT NO.		HIGHWAY NO.
BLS	6	(SEE TITLE SHEET)		IH 20
CHECK	STATE	DISTRICT	COUNTY	SHEET NO.
BLS	TEXAS	DAL	VARIOUS	256
CHECK	CONTROL	SECTION	JOB	
MA	0095	14	033, ETC	

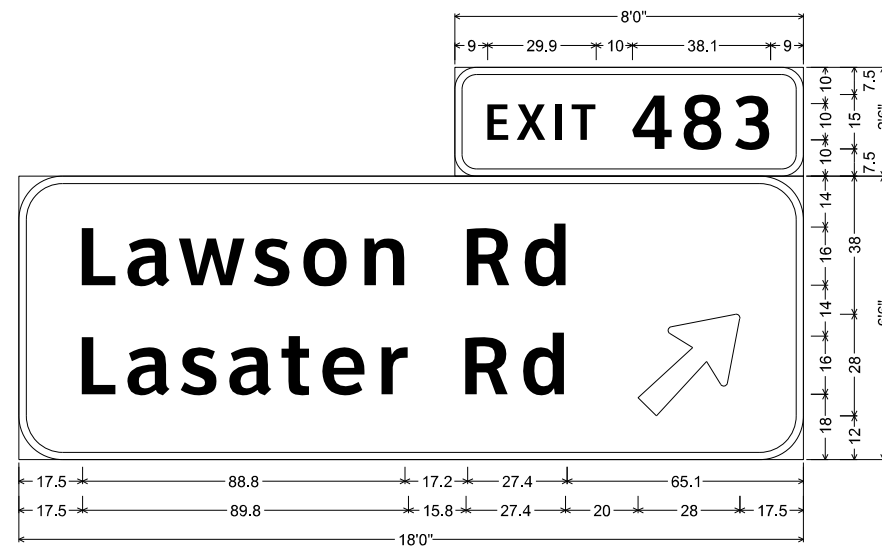

6.0" Radius, 2.0" Border, White on Green;
 "EXIT 483", ClearviewHwy-4-W;
 12.0" Radius, 2.0" Border, White on Green;
 "Lawson Rd", ClearviewHwy-5-W-R; "Lasater Rd", ClearviewHwy-5-W-R; Arrow A-3 - 35.6" 45°;

SHEET 55 SIGN 6

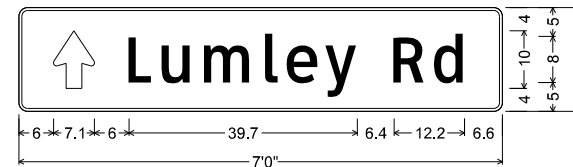

D1-1 8in UP;
 1.5" Radius, 0.5" Border, White on Green;
 Standard Arrow Custom 10.0" X 7.1" 90°;
 "Lumley Rd", ClearviewHwy-3-W;

SHEET 55 SIGN 7

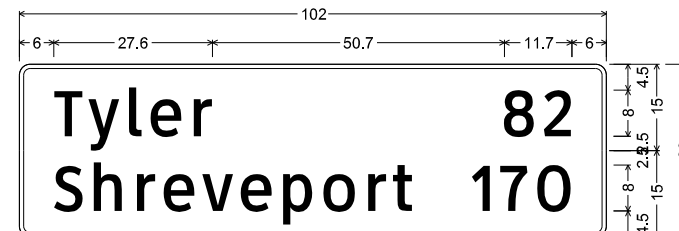

D2-2 8in;
 1.9" Radius, 0.8" Border, White on Green;
 "Tyler", ClearviewHwy-3-W; "82", ClearviewHwy-3-W;
 1.9" Radius, 0.8" Border, White on Green;
 "Shreveport", ClearviewHwy-3-W; "170", ClearviewHwy-3-W;

SHEET 57 SIGN 4

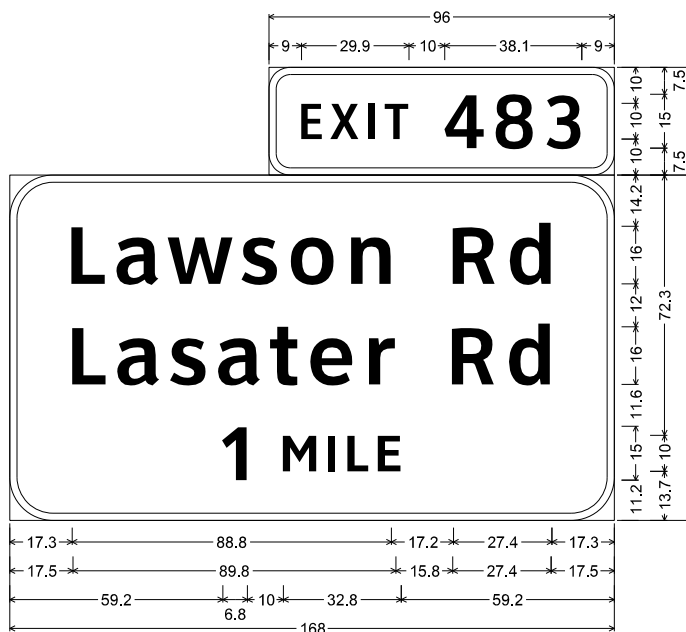

6.0" Radius, 2.0" Border, White on Green;
 "EXIT 483", ClearviewHwy-4-W;
 12.0" Radius, 2.0" Border, White on Green;
 "Lawson Rd", ClearviewHwy-5-W-R; "Lasater Rd", ClearviewHwy-5-W-R;
 "1", ClearviewHwy-5-W-R; "MILE", ClearviewHwy-5-W-R;

SHEET 57 SIGN 1

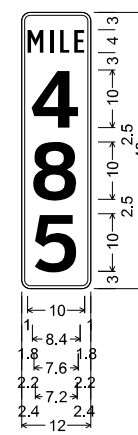

D10-3 10in;
 1.5" Radius, 0.5" Border, White on Green;
 "MILE", ClearviewHwy-2-W;
 "4", ClearviewHwy-6-W;
 "8", ClearviewHwy-6-W;
 "5", ClearviewHwy-6-W;

SHEET 57 SIGN 2
SHEET 57 SIGN 3

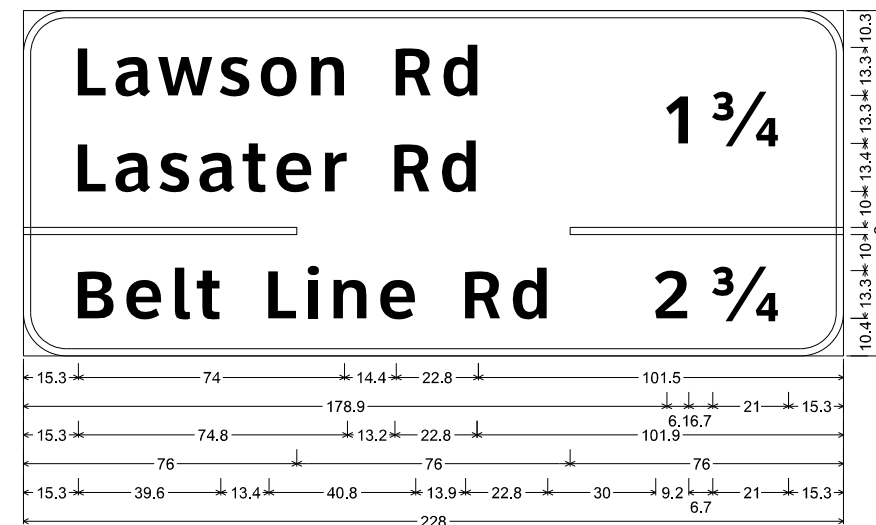

12.0" Radius, 2.0" Border, White on Green;
 "Lawson Rd", ClearviewHwy-5-W-R; "1 3/4", ClearviewHwy-5-W-R; "Lasater Rd", ClearviewHwy-5-W-R;
 "Belt Line Rd", ClearviewHwy-5-W-R; "2 3/4", ClearviewHwy-5-W-R;

SHEET 58 SIGN 1

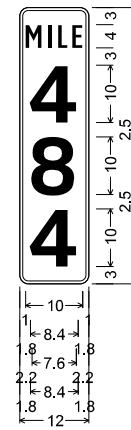

D10-3 10in;
 1.5" Radius, 0.5" Border, White on Green;
 "MILE", ClearviewHwy-2-W;
 "4", ClearviewHwy-6-W;
 "8", ClearviewHwy-6-W;
 "4", ClearviewHwy-6-W;

SHEET 56 SIGN 1
SHEET 56 SIGN 2

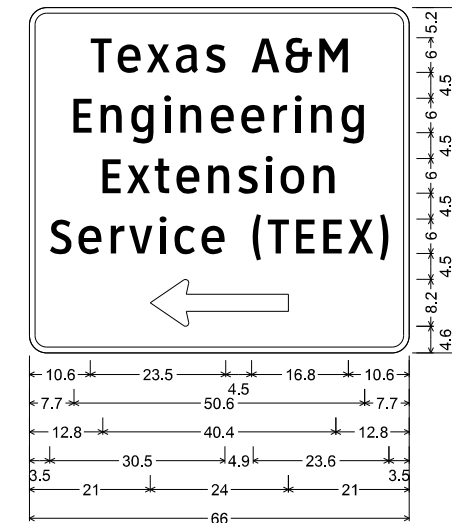

D3-3bTL ;
 3.0" Radius, 1.0" Border, White on Green;
 "Texas A&M", ClearviewHwy-3-W;
 "Engineering", ClearviewHwy-3-W;
 "Extension", ClearviewHwy-3-W;
 "Service (TEEX)", ClearviewHwy-3-W;
 Standard Arrow Custom 24.0" X 8.1" 180°;

SHEET 56 SIGN 3

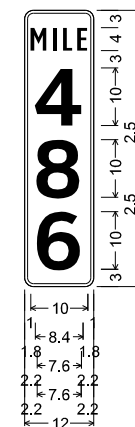

D10-3 10in;
 1.5" Radius, 0.5" Border, White on Green;
 "MILE", ClearviewHwy-2-W;
 "4", ClearviewHwy-6-W;
 "8", ClearviewHwy-6-W;
 "6", ClearviewHwy-6-W;

SHEET 59 SIGN 1
SHEET 59 SIGN 2

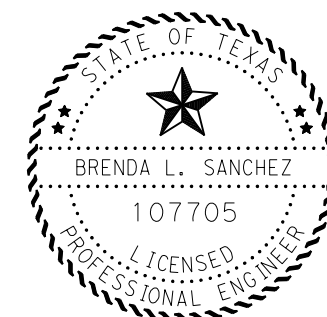

Brenda L Sanchez, P.E. 03/20/23
 Signature of Registrar & Date



GUIDE SIGN DETAILS

SCALE: NTS SHEET 32 OF 47

DESIGN/CK	FED. RD. DIV. NO.	STATE PROJECT NO.		HIGHWAY NO.
BLS	6	(SEE TITLE SHEET)		IH 20
BLS	STATE	DISTRICT	COUNTY	SHEET NO.
MA	TEXAS	DAL	VARIOUS	257
BA	CONTROL	SECTION	JOB	
	0095	14	033, ETC	

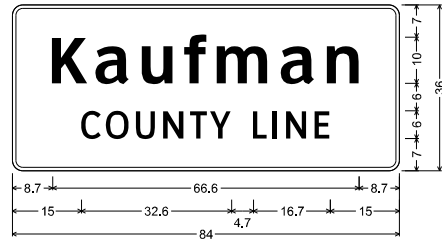

I-2dT 10in;
2.3" Radius, 0.8" Border, White on Green;
"Kaufman", ClearviewHwy-5-W-R;
"COUNTY LINE", ClearviewHwy-3-W;

SHEET 60 SIGN 2
SHEET 111 SIGN 1

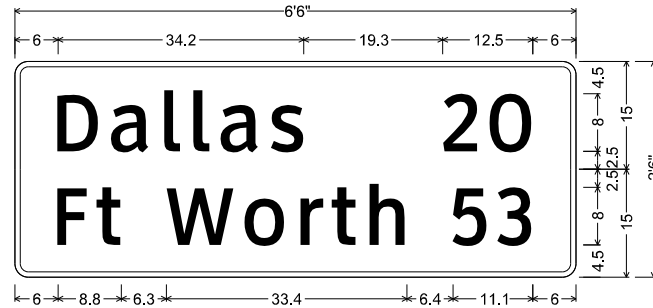

D2-2 8in;
1.9" Radius, 0.8" Border, White on Green;
"Dallas", ClearviewHwy-3-W; "20", ClearviewHwy-3-W;
1.9" Radius, 0.8" Border, White on Green;
"Ft Worth", ClearviewHwy-3-W; "53", ClearviewHwy-3-W;

SHEET 61 SIGN 1

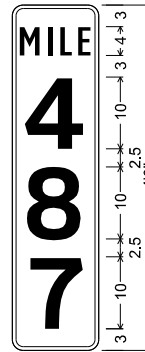

D10-3 10in;
1.5" Radius, 0.5" Border, White on Green;
"MILE", ClearviewHwy-2-W;
"4", ClearviewHwy-6-W;
"8", ClearviewHwy-6-W;
"7", ClearviewHwy-6-W;

SHEET 61 SIGN 2
SHEET 61 SIGN 3

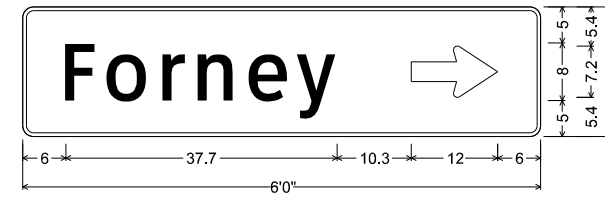

D1-1 8in RT;
1.5" Radius, 0.5" Border, White on Green;
"Forney", ClearviewHwy-3-W;
Standard Arrow Custom 12.0" X 7.1" 0°;

SHEET 62 SIGN 2
SHEET 68 SIGN 3

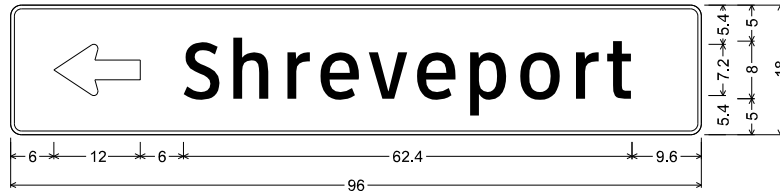

D1-1 8in LT;
1.5" Radius, 0.5" Border, White on Green;
Standard Arrow Custom 12.0" X 7.1" 180°; "Shreveport", ClearviewHwy-3-W;

SHEET 62 SIGN 5 SHEET 82 SIGN 10
SHEET 68 SIGN 1 SHEET 85 SIGN 8
SHEET 70 SIGN 6 SHEET 97 SIGN 5
SHEET 70 SIGN 7 SHEET 109 SIGN 6

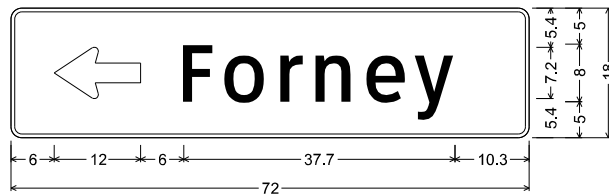

D1-1 8in LT;
1.5" Radius, 0.5" Border, White on Green;
Standard Arrow Custom 12.0" X 7.1" 180°;
"Forney", ClearviewHwy-3-W;

SHEET 62 SIGN 6
SHEET 67 SIGN 6

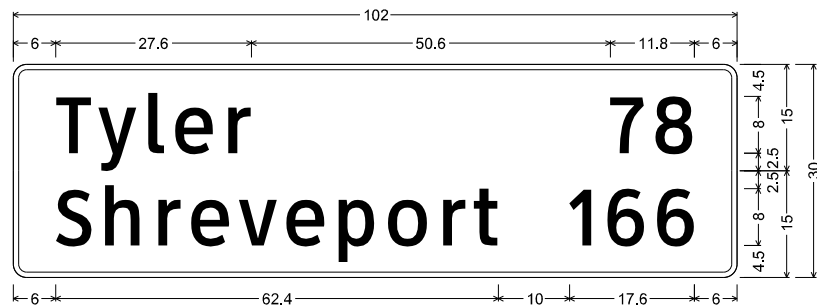

D2-2 8in;
1.9" Radius, 0.8" Border, White on Green;
"Tyler", ClearviewHwy-3-W; "78", ClearviewHwy-3-W;
1.9" Radius, 0.8" Border, White on Green;
"Shreveport", ClearviewHwy-3-W; "166", ClearviewHwy-3-W;

SHEET 64 SIGN 1

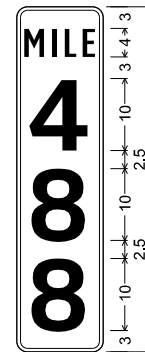

D10-3 10in;
1.5" Radius, 0.5" Border, White on Green;
"MILE", ClearviewHwy-2-W;
"8", ClearviewHwy-6-W;
"8", ClearviewHwy-6-W;

SHEET 63 SIGN 2
SHEET 63 SIGN 3

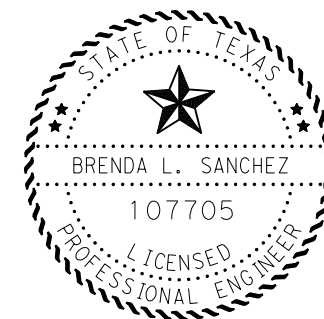

Brenda L Sanchez, P.E. 03/20/23
Signature of Registrar & Date



GUIDE SIGN DETAILS

SCALE: NTS SHEET 33 OF 47

DESIGN/CK	FED. RD. DIV. NO.	STATE PROJECT NO.			HIGHWAY NO.
BLS	6	(SEE TITLE SHEET)			IH 20
BLS	STATE	DISTRICT	COUNTY	SHEET NO.	
MA	TEXAS	DAL	VARIOUS	258	
CK	CONTROL	SECTION	JOB		
BA	0095	14	033, ETC		

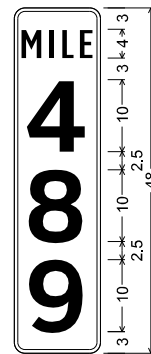

D10-3 10in;
1.5" Radius, 0.5" Border, White on Green;
"MILE", ClearviewHwy-2-W;
"4", ClearviewHwy-6-W;
"8", ClearviewHwy-6-W;
"9", ClearviewHwy-6-W;

SHEET 65 SIGN 1
SHEET 65 SIGN 2

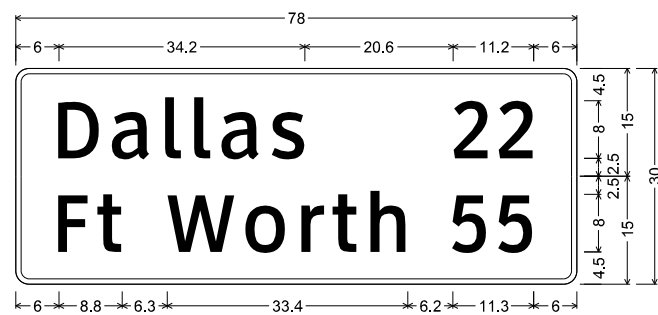

D2-2 8in;
1.9" Radius, 0.8" Border, White on Green;
"Dallas", ClearviewHwy-3-W; "22", ClearviewHwy-3-W;
1.9" Radius, 0.8" Border, White on Green;
"Ft Worth", ClearviewHwy-3-W; "55", ClearviewHwy-3-W;

SHEET 66 SIGN 1

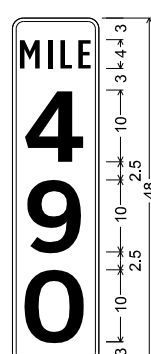

D10-3 10in;
1.5" Radius, 0.5" Border, White on Green;
"MILE", ClearviewHwy-2-W;
"4", ClearviewHwy-6-W;
"9", ClearviewHwy-6-W;
"0", ClearviewHwy-6-W;

SHEET 67 SIGN 1
SHEET 67 SIGN 2

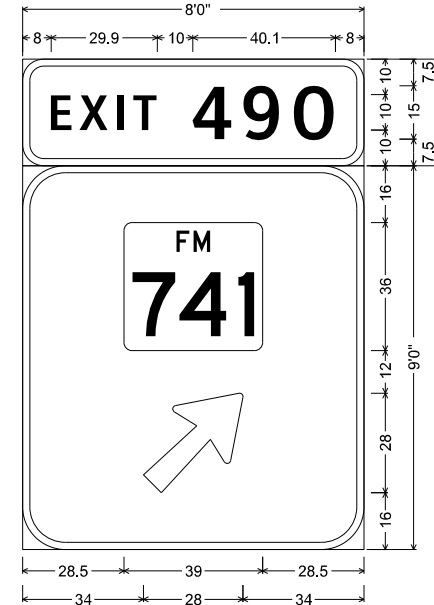

6.0" Radius, 2.0" Border, White on Green;
"EXIT", ClearviewHwy-4-W;
"490", ClearviewHwy-4-W;
12.0" Radius, 2.0" Border, White on Green;
State Highway 741 M1-6F3;
Arrow A-3 - 35.6" 45";
SHEET 67 SIGN 4

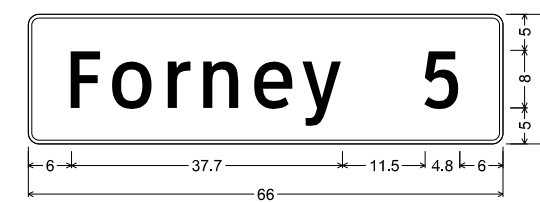

D2-1 8in;
1.5" Radius, 0.5" Border, White on Green;
"Forney", ClearviewHwy-3-W; "5", ClearviewHwy-3-W;

SHEET 68 SIGN 4

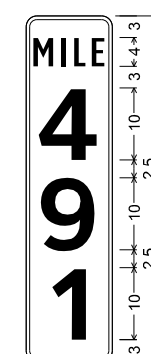

D10-3 10in;
1.5" Radius, 0.5" Border, White on Green;
"MILE", ClearviewHwy-2-W;
"4", ClearviewHwy-6-W;
"9", ClearviewHwy-6-W;
"1", ClearviewHwy-6-W;

SHEET 69 SIGN 1
SHEET 69 SIGN 2

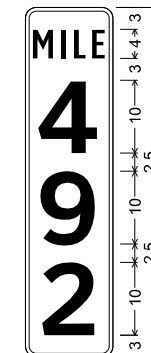

D10-3 10in;
1.5" Radius, 0.5" Border, White on Green;
"MILE", ClearviewHwy-2-W;
"4", ClearviewHwy-6-W;
"9", ClearviewHwy-6-W;
"2", ClearviewHwy-6-W;

SHEET 71 SIGN 1
SHEET 71 SIGN 2

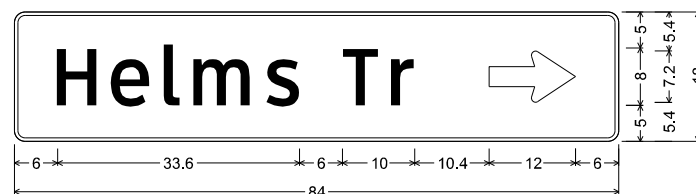

D1-1 8in RT;
1.5" Radius, 0.5" Border, White on Green;
"Helms Tr", ClearviewHwy-3-W; Standard Arrow Custom 12.0" X 7.1" 0°;

SHEET 70 SIGN 3



D1-1 8in LT;
1.5" Radius, 0.5" Border, White on Green;
Standard Arrow Custom 12.0" X 7.1" 180°; "Helms Tr", ClearviewHwy-3-W;

SHEET 70 SIGN 8

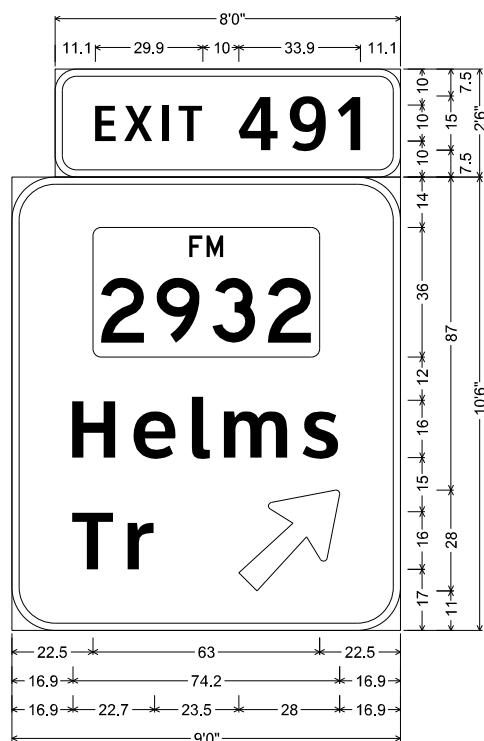

6.0" Radius, 2.0" Border, White on Green;
"EXIT", ClearviewHwy-4-W;
"491", ClearviewHwy-4-W;
12.0" Radius, 2.0" Border, White on Green;
State Highway 2932 M1-6F4;
"Helms", ClearviewHwy-5-W-R;
"Tr", ClearviewHwy-5-W-R;
Arrow A-3 - 35.6" 45°;

SHEET 69 SIGN 5

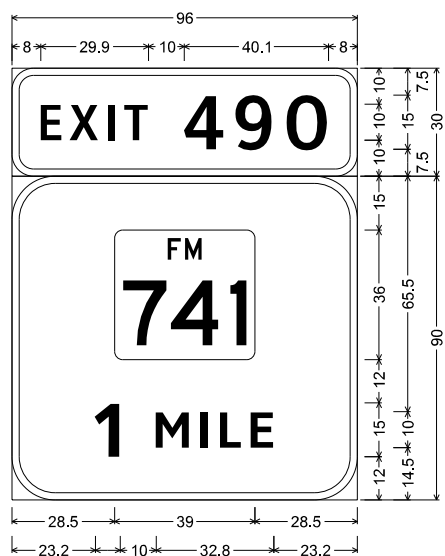

6.0" Radius, 2.0" Border, White on Green;
"EXIT", ClearviewHwy-4-W;
"490", ClearviewHwy-4-W;
12.0" Radius, 2.0" Border, White on Green;
State Highway 741 M1-6F3;
"1", ClearviewHwy-5-W-R;
"MILE", ClearviewHwy-5-W-R;

SHEET 70 SIGN 4



D1-1 8in RT;
1.5" Radius, 0.5" Border, White on Green;
"Shreveport", ClearviewHwy-3-W; Standard Arrow Custom 12.0" X 7.1" 0°;

SHEET 70 SIGN 9

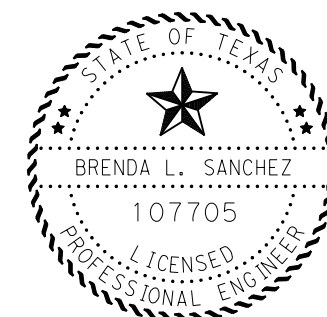

Brenda L Sanchez, P.E. 03/20/23
Signature of Registrant & Date

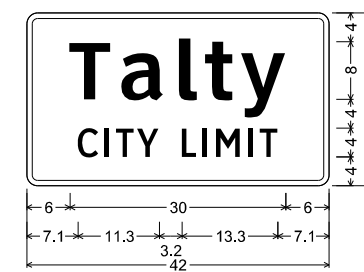

I-2aT 8in;
1.5" Radius, 0.8" Border, White on Green;
"Talty", ClearviewHwy-5-W-R;
"CITY LIMIT", ClearviewHwy-3-W;

SHEET 71 SIGN 3
SHEET 75 SIGN 1

GUIDE SIGN DETAILS

SCALE: NTS			SHEET 34 OF 47	
DESIGN/CK BLS	FED. RD. DIV. NO. 6	STATE PROJECT NO. (SEE TITLE SHEET)		HIGHWAY NO. IH 20
CHECK BLS	STATE	DISTRICT DAL	COUNTY VARIOUS	SHEET NO. 259
CHECK MA	TEXAS	SECTION 0095	JOB 14 033, ETC	
CHECK BA	CONTROL			

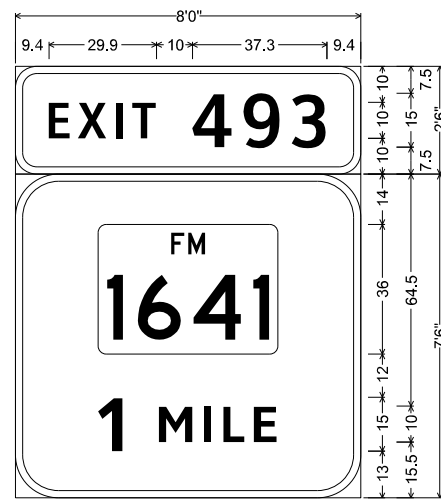

6.0" Radius, 2.0" Border, White on Green;
 "EXIT", ClearviewHwy-4-W;
 "493", ClearviewHwy-4-W;
 12.0" Radius, 2.0" Border, White on Green;
 State Highway 1641 M1-6F4;
 "1", ClearviewHwy-5-W-R;
 "MILE", ClearviewHwy-5-W-R;

SHEET 71 SIGN 4
 SHEET 76 SIGN 1

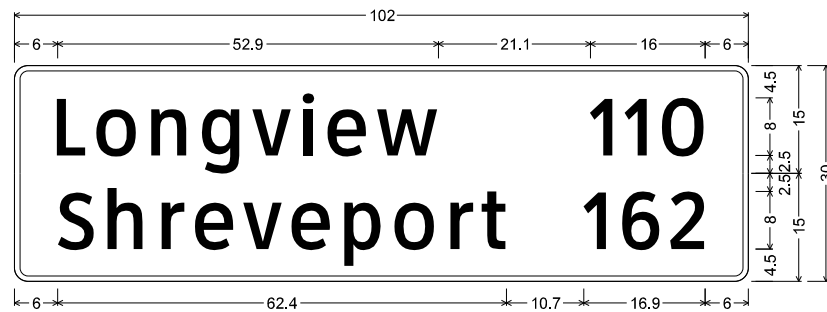

D2-2 8in;
 1.9" Radius, 0.8" Border, White on Green;
 "Longview", ClearviewHwy-3-W; "110", ClearviewHwy-3-W;
 1.9" Radius, 0.8" Border, White on Green;
 "Shreveport", ClearviewHwy-3-W; "162", ClearviewHwy-3-W;

SHEET 71 SIGN 5

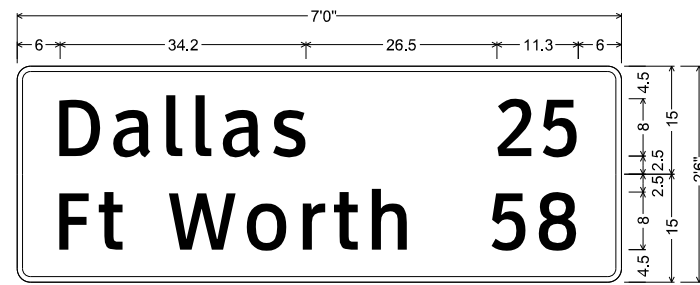

D2-2 8in;
 1.9" Radius, 0.8" Border, White on Green;
 "Dallas", ClearviewHwy-3-W; "25", ClearviewHwy-3-W;
 1.9" Radius, 0.8" Border, White on Green;
 "Ft Worth", ClearviewHwy-3-W; "58", ClearviewHwy-3-W;

SHEET 72 SIGN 1

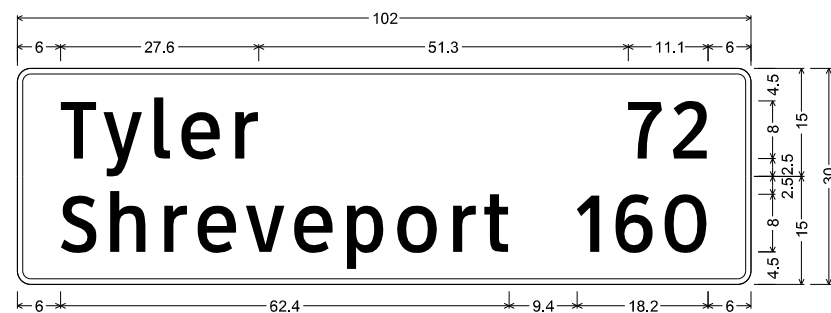

D2-2 8in;
 1.9" Radius, 0.8" Border, White on Green;
 "Tyler", ClearviewHwy-3-W; "72", ClearviewHwy-3-W;
 1.9" Radius, 0.8" Border, White on Green;
 "Shreveport", ClearviewHwy-3-W; "160", ClearviewHwy-3-W;

SHEET 75 SIGN 2

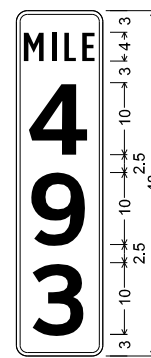

D10-3 10in;
 1.5" Radius, 0.5" Border, White on Green;
 "MILE", ClearviewHwy-2-W;
 "4", ClearviewHwy-6-W;
 "9", ClearviewHwy-6-W;
 "3", ClearviewHwy-6-W;

SHEET 72 SIGN 2
 SHEET 72 SIGN 3

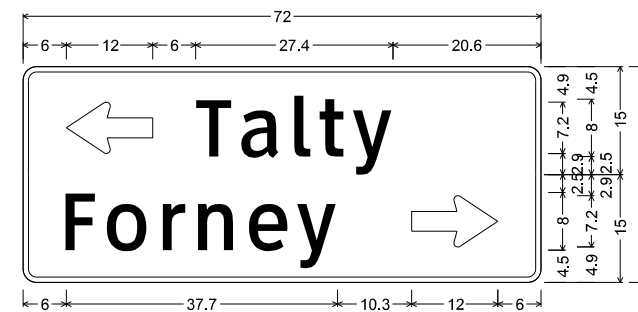

D1-2 8in LT-RT;
 1.9" Radius, 0.8" Border, White on Green;
 Standard Arrow Custom 12.0" X 7.1" 180°;
 "Talty", ClearviewHwy-3-W;
 1.9" Radius, 0.8" Border, White on Green;
 "Forney", ClearviewHwy-3-W;
 Standard Arrow Custom 12.0" X 7.1" 0°;

SHEET 73 SIGN 2

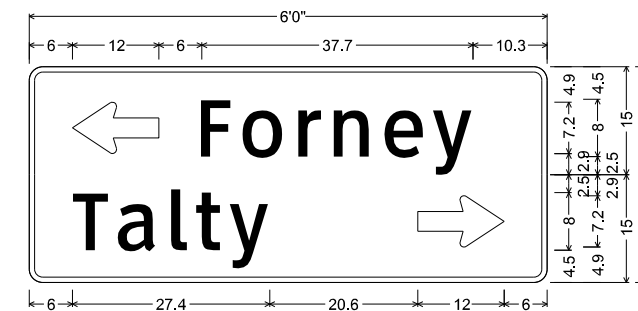

D1-2 8in LT-RT;
 1.9" Radius, 0.8" Border, White on Green;
 Standard Arrow Custom 12.0" X 7.1" 180°;
 "Forney", ClearviewHwy-3-W;
 1.9" Radius, 0.8" Border, White on Green;
 "Talty", ClearviewHwy-3-W;
 Standard Arrow Custom 12.0" X 7.1" 0°;

SHEET 73 SIGN 6

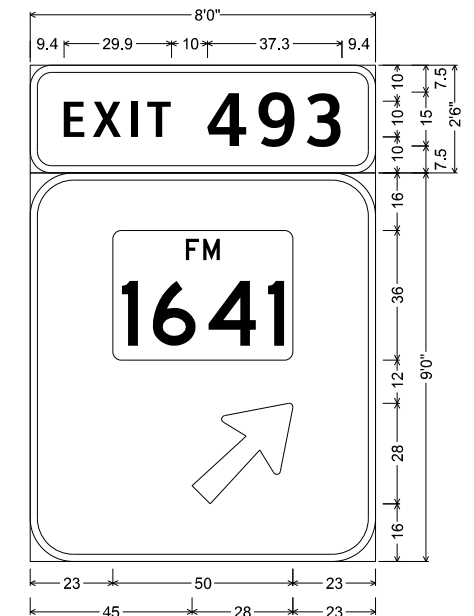

6.0" Radius, 2.0" Border, White on Green;
 "EXIT", ClearviewHwy-4-W;
 "493", ClearviewHwy-4-W;
 12.0" Radius, 2.0" Border, White on Green;
 State Highway 1641 M1-6F4;
 Arrow A-3 - 35.6° 45°;

SHEET 73 SIGN 4
 SHEET 74 SIGN 2

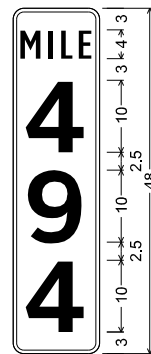

D10-3 10in;
 1.5" Radius, 0.5" Border, White on Green;
 "MILE", ClearviewHwy-2-W;
 "4", ClearviewHwy-6-W;
 "9", ClearviewHwy-6-W;
 "4", ClearviewHwy-6-W;

SHEET 74 SIGN 3
 SHEET 74 SIGN 4

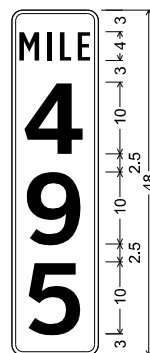

D10-3 10in;
 1.5" Radius, 0.5" Border, White on Green;
 "MILE", ClearviewHwy-2-W;
 "4", ClearviewHwy-6-W;
 "5", ClearviewHwy-6-W;

SHEET 76 SIGN 2
 SHEET 76 SIGN 3

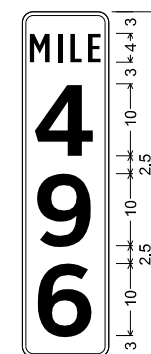

D10-3 10in;
 1.5" Radius, 0.5" Border, White on Green;
 "MILE", ClearviewHwy-2-W;
 "4", ClearviewHwy-6-W;
 "9", ClearviewHwy-6-W;
 "6", ClearviewHwy-6-W;

SHEET 78 SIGN 1
 SHEET 78 SIGN 2

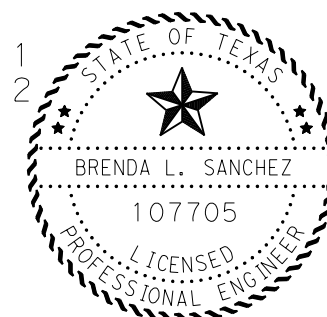

Brenda L Sanchez, P.E. 03/20/23
 Signature of Registrar & Date

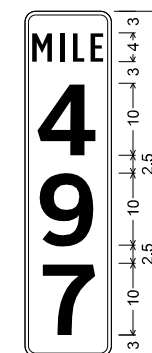

D10-3 10in;
 1.5" Radius, 0.5" Border, White on Green;
 "MILE", ClearviewHwy-2-W;
 "4", ClearviewHwy-6-W;
 "9", ClearviewHwy-6-W;
 "7", ClearviewHwy-6-W;

SHEET 80 SIGN 1
 SHEET 80 SIGN 2

Texas Department of Transportation
 ©2023

GUIDE SIGN DETAILS

SCALE: NTS SHEET 35 OF 47

DESIGN/CK	FED. RD. DIV. NO.	STATE PROJECT NO.		HIGHWAY NO.
BLS	6	(SEE TITLE SHEET)		IH 20
CHECK	STATE	DISTRICT	COUNTY	SHEET NO.
BLS	TEXAS	DAL	VARIOUS	260
CHECK	CONTROL	SECTION	JOB	
MA	0095	14	033, ETC	

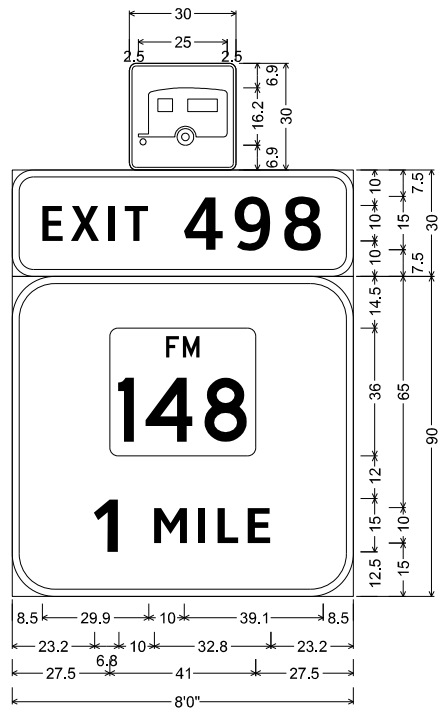

D9-3a_30x30;
1.9" Radius, 0.8" Border, White on Blue;
RM-020;

6.0" Radius, 2.0" Border, White on Green;
"EXIT", ClearviewHwy-4-W;
"498", ClearviewHwy-4-W;

12.0" Radius, 2.0" Border, White on Green;
State Highway 148 M1-6F3;
"1", ClearviewHwy-5-W-R;
"MILE", ClearviewHwy-5-W-R;

SHEET 80 SIGN 3

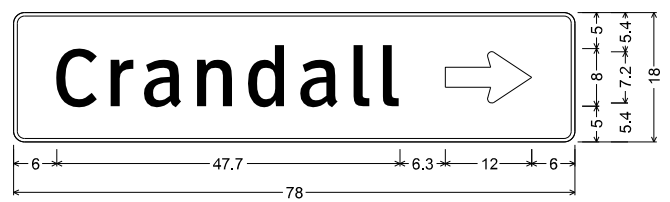

D1-1 8in RT;
1.5" Radius, 0.5" Border, White on Green;
"Crandall", ClearviewHwy-3-W; Standard Arrow Custom 12.0" X 7.1" 0°;

SHEET 82 SIGN 7

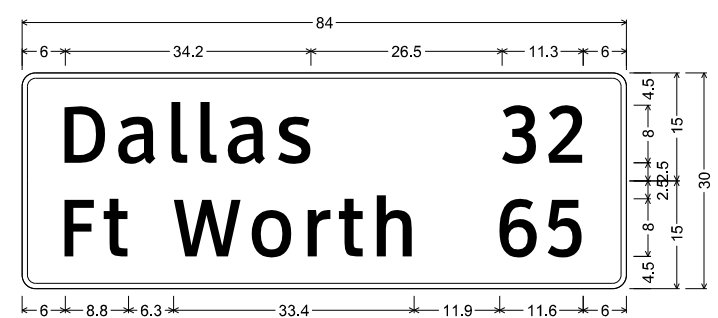

D2-2 8in;
1.9" Radius, 0.8" Border, White on Green;
"Dallas", ClearviewHwy-3-W; "32", ClearviewHwy-3-W;

1.9" Radius, 0.8" Border, White on Green;
"Ft Worth", ClearviewHwy-3-W; "65", ClearviewHwy-3-W;

SHEET 83 SIGN 1

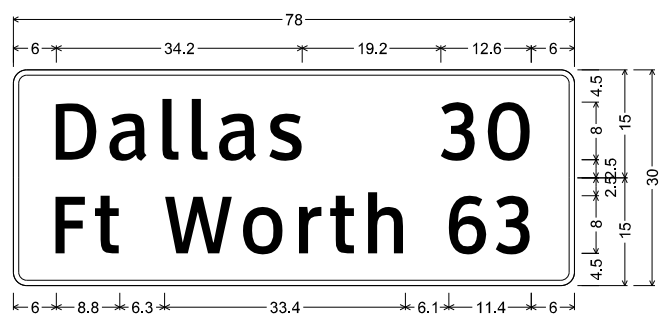

D2-2 8in;
1.9" Radius, 0.8" Border, White on Green;
"Dallas", ClearviewHwy-3-W; "30", ClearviewHwy-3-W;

1.9" Radius, 0.8" Border, White on Green;
"Ft Worth", ClearviewHwy-3-W; "63", ClearviewHwy-3-W;

SHEET 81 SIGN 1

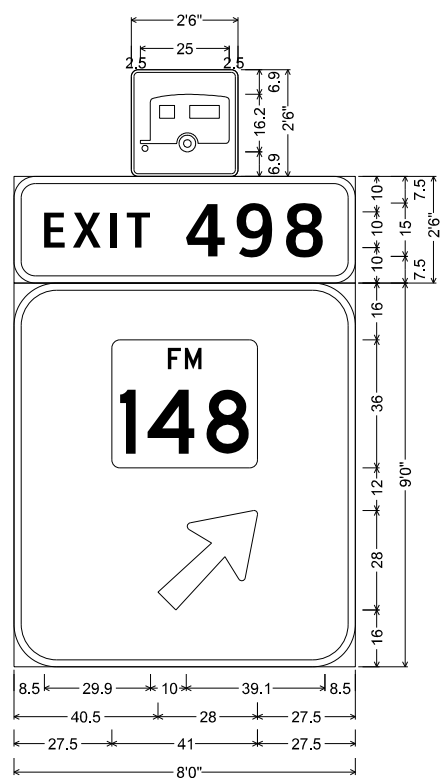

D9-3a_30x30;
1.9" Radius, 0.8" Border, White on Blue;
RM-020;

6.0" Radius, 2.0" Border, White on Green;
"EXIT", ClearviewHwy-4-W;
"498", ClearviewHwy-4-W;

12.0" Radius, 2.0" Border, White on Green;
State Highway 148 M1-6F3;
Arrow A-3 - 35.6" 45°;

SHEET 82 SIGN 5

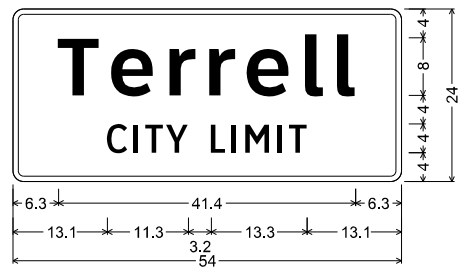

I-2aT 8in;
1.5" Radius, 0.8" Border, White on Green;
"Terrell", ClearviewHwy-5-W-R;
"CITY LIMIT", ClearviewHwy-3-W;

SHEET 81 SIGN 2

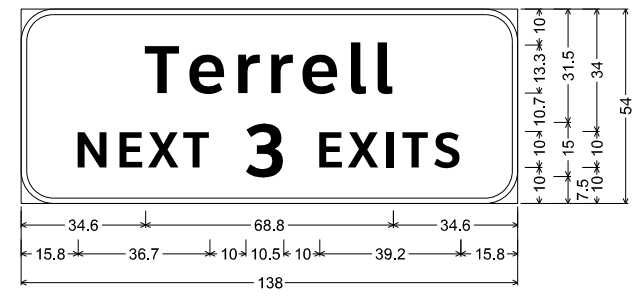

9.0" Radius, 1.5" Border, White on Green;
"Terrell", ClearviewHwy-5-W-R; "NEXT", ClearviewHwy-5-W-R;
"3", ClearviewHwy-5-W-R; "EXITS", ClearviewHwy-5-W-R;

SHEET 81 SIGN 3
SHEET 92 SIGN 1

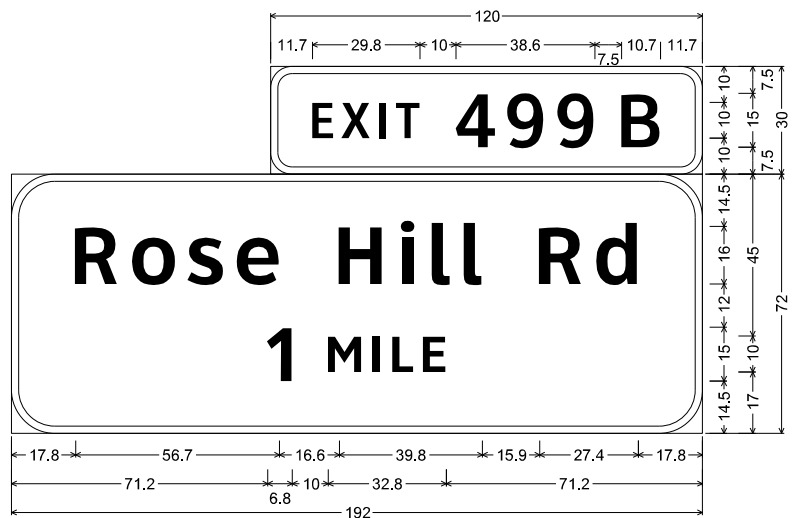

6.0" Radius, 2.0" Border, White on Green;
"EXIT", ClearviewHwy-4-W; "499 B", ClearviewHwy-4-W;

12.0" Radius, 2.0" Border, White on Green;
"Rose Hill Rd", ClearviewHwy-5-W-R; "1 MILE", ClearviewHwy-5-W-R;

SHEET 82 SIGN 9

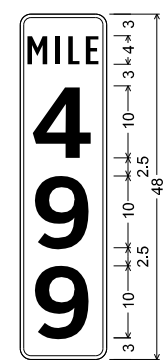

D10-3 10in;
1.5" Radius, 0.5" Border, White on Green;
"MILE", ClearviewHwy-2-W;
"4", ClearviewHwy-6-W;
"9", ClearviewHwy-6-W;
"9", ClearviewHwy-6-W;

SHEET 84 SIGN 1
SHEET 84 SIGN 2

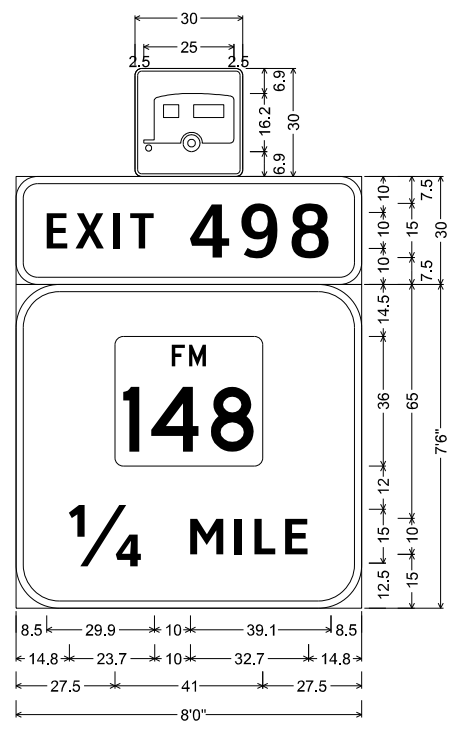

D9-3a_30x30;
1.9" Radius, 0.8" Border, White on Blue;
RM-020;

6.0" Radius, 2.0" Border, White on Green;
"EXIT", ClearviewHwy-4-W;
"498", ClearviewHwy-4-W;

12.0" Radius, 2.0" Border, White on Green;
State Highway 148 M1-6F3;
"1/4", ClearviewHwy-5-W-R;
"MILE", ClearviewHwy-5-W-R;

SHEET 84 SIGN 3

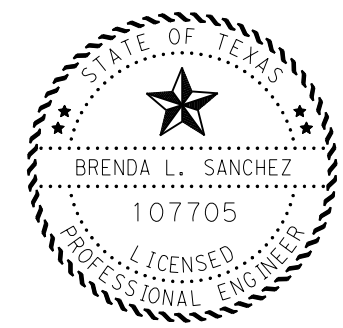

Brenda L Sanchez, P.E. 03/20/23
Signature of Registrant & Date

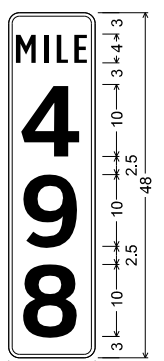

D10-3 10in;
1.5" Radius, 0.5" Border, White on Green;
"MILE", ClearviewHwy-2-W;
"4", ClearviewHwy-6-W;
"9", ClearviewHwy-6-W;
"8", ClearviewHwy-6-W;

SHEET 82 SIGN 1
SHEET 82 SIGN 2



GUIDE SIGN DETAILS

SCALE: NTS SHEET 36 OF 47

DESIGN/CK BLS	FED. RD. DIV. NO. 6	STATE PROJECT NO. (SEE TITLE SHEET)		HIGHWAY NO. IH 20
CHECK BLS	STATE	DISTRICT DAL	COUNTY VARIOUS	SHEET NO. 261
CHECK MA	TEXAS	SECTION CONTROL	JOB 033, ETC	
CHECK BA	0095	14		

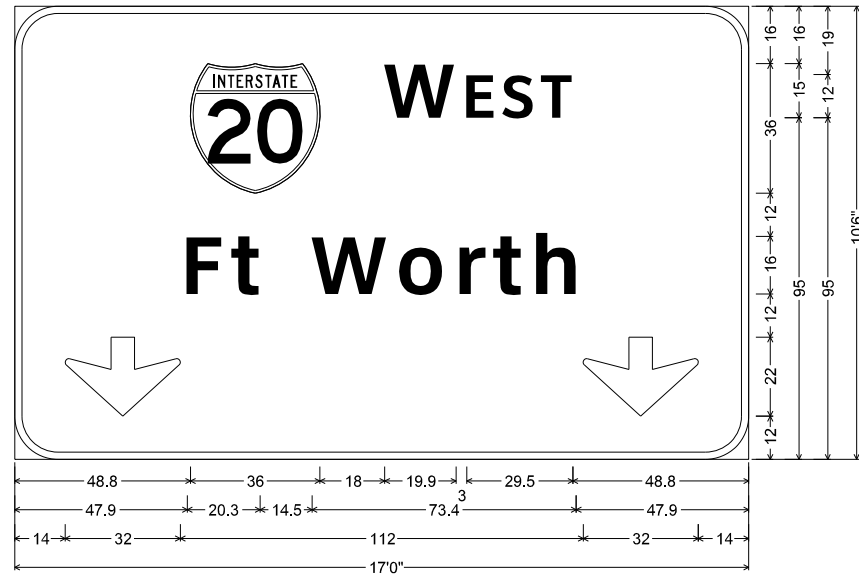

12.0" Radius, 2.0" Border, White on Green;
 Interstate 20 M1-1; "W EST", ClearviewHwy-5-W-R; "Ft Worth", ClearviewHwy-5-W-R;
 Down Arrow 22 - 22.0" 270"; Down Arrow 22 - 22.0" 270";

SHEET 84 SIGN 4

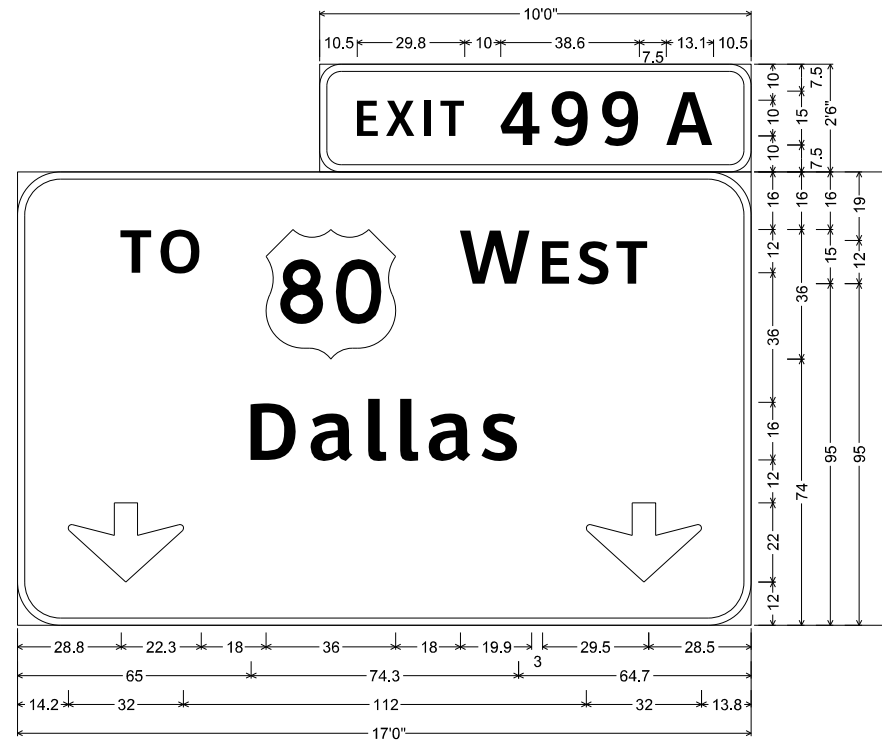

6.0" Radius, 2.0" Border, White on Green;
 "EXIT", ClearviewHwy-4-W; "499", ClearviewHwy-4-W; "A", ClearviewHwy-4-W;
 12.0" Radius, 2.0" Border, White on Green;
 "TO", ClearviewHwy-5-W-R; US 80 M1-4; "W EST", ClearviewHwy-5-W-R;
 "Dallas", ClearviewHwy-5-W-R; Down Arrow 22 - 22.0" 270"; Down Arrow 22 - 22.0" 270";

SHEET 84 SIGN 5

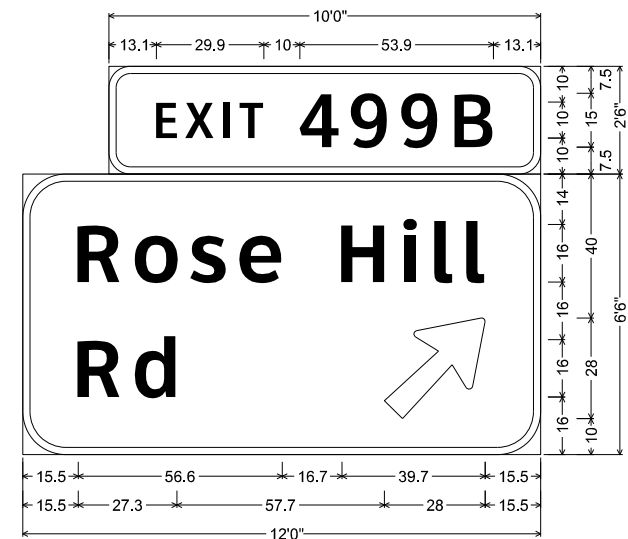

6.0" Radius, 2.0" Border, White on Green;
 "EXIT", ClearviewHwy-4-W; "499B", ClearviewHwy-4-W;
 12.0" Radius, 2.0" Border, White on Green;
 "Rose Hill", ClearviewHwy-5-W-R; "Rd", ClearviewHwy-5-W-R;
 Arrow A-3 - 35.6" 45";

SHEET 84 SIGN 7
SHEET 85 SIGN 6

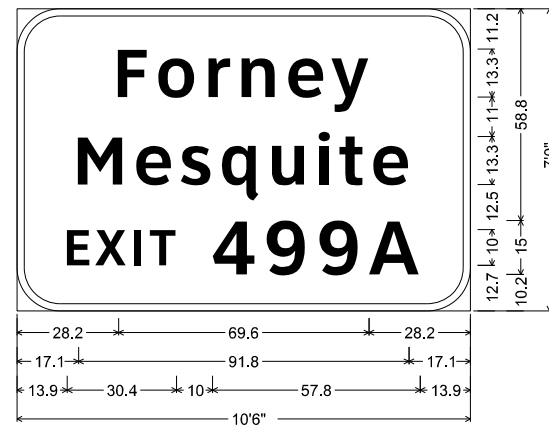

12.0" Radius, 2.0" Border, White on Green;
 "Forney", ClearviewHwy-5-W-R;
 "Mesquite", ClearviewHwy-5-W-R;
 "EXIT", ClearviewHwy-5-W-R;
 "499A", ClearviewHwy-5-W-R;

SHEET 85 SIGN 1

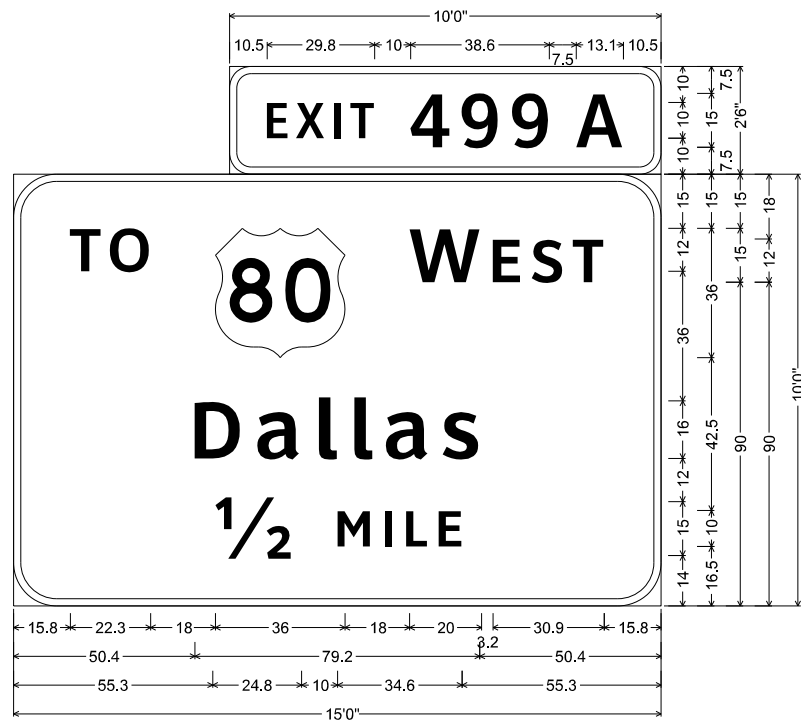

6.0" Radius, 2.0" Border, White on Green;
 "EXIT", ClearviewHwy-4-W; "499", ClearviewHwy-4-W; "A", ClearviewHwy-4-W;
 12.0" Radius, 2.0" Border, White on Green;
 "TO", ClearviewHwy-5-W-R; US 80 M1-4; "W EST", ClearviewHwy-5-W-R;
 "Dallas", ClearviewHwy-5-W-R; "1/2", ClearviewHwy-5-W-R; "MILE", ClearviewHwy-5-W-R;

SHEET 85 SIGN 4

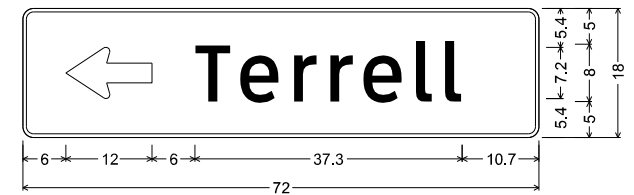

D1-1 8In LT;
 1.5" Radius, 0.5" Border, White on Green;
 Standard Arrow Custom 12.0" X 7.1" 180";
 "Terrell", ClearviewHwy-3-W;

SHEET 85 SIGN 7

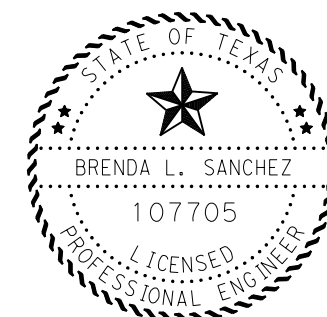

Brenda L Sanchez, P.E. 03/20/23
 Signature of Registrant & Date

 Texas Department of Transportation © 2023			
GUIDE SIGN DETAILS			
SCALE: NTS		SHEET 37 OF 47	
DESIGN/CK BLS	FED. RD. DIV. NO. 6	STATE PROJECT NO. (SEE TITLE SHEET)	
CHECK BLS	STATE	DISTRICT DAL	HIGHWAY NO. IH 20
CHECK MA	TEXAS	COUNTY VARIOUS	SHEET NO. 262
CHECK BA	CONTROL 0095	SECTION 14	JOB 033, ETC

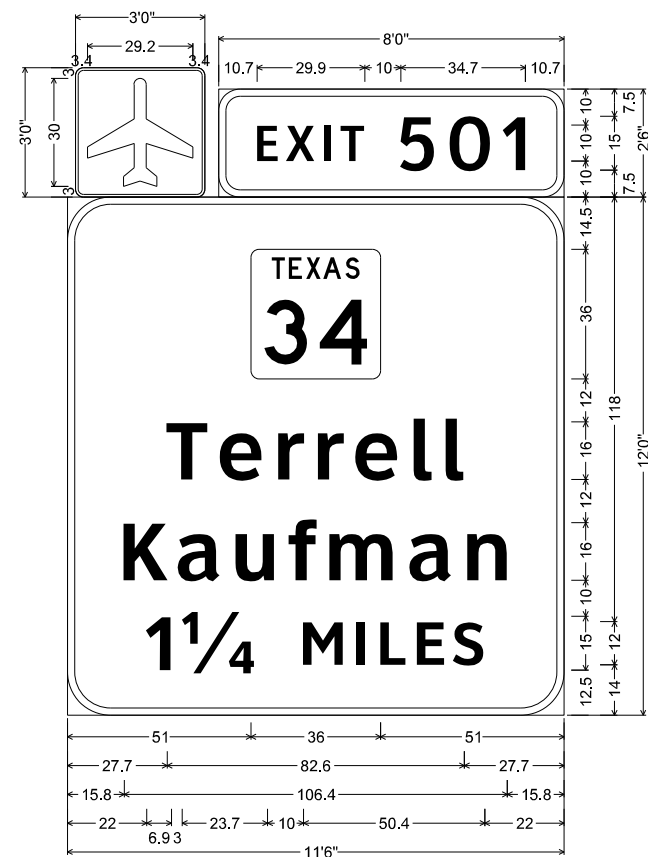

I-5_36x36;
2.3" Radius, 0.8" Border, White on Green;
Symbol I-5;

6.0" Radius, 2.0" Border, White on Green;
"EXIT", ClearviewHwy-4-W; "501", ClearviewHwy-4-W;

12.0" Radius, 2.0" Border, White on Green;
State Highway 34 M1-6T2; "Terrell", ClearviewHwy-5-W-R;
"Kaufman", ClearviewHwy-5-W-R; "1 1/4", ClearviewHwy-5-W-R;
"MILES", ClearviewHwy-5-W-R;

SHEET 85 SIGN 10

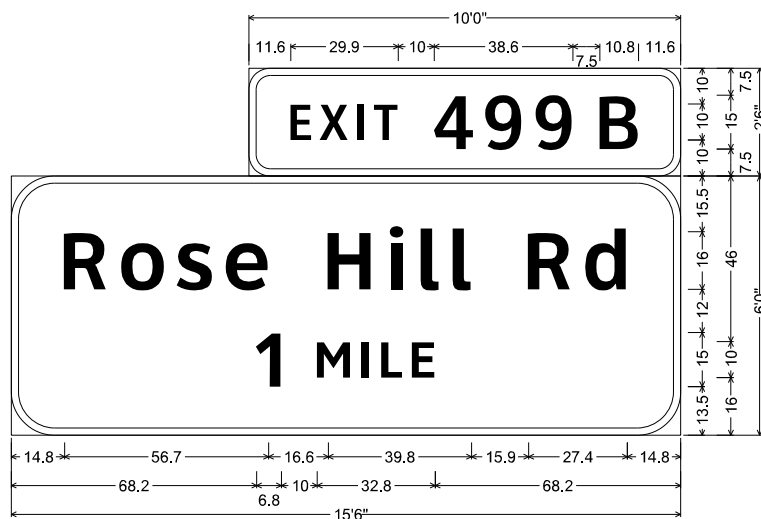

6.0" Radius, 2.0" Border, White on Green;
"EXIT", ClearviewHwy-4-W; "499", ClearviewHwy-4-W; "B", ClearviewHwy-4-W;

12.0" Radius, 2.0" Border, White on Green;
"Rose Hill Rd", ClearviewHwy-5-W-R; "1", ClearviewHwy-5-W-R;
"MILE", ClearviewHwy-5-W-R;

SHEET 87 SIGN 3

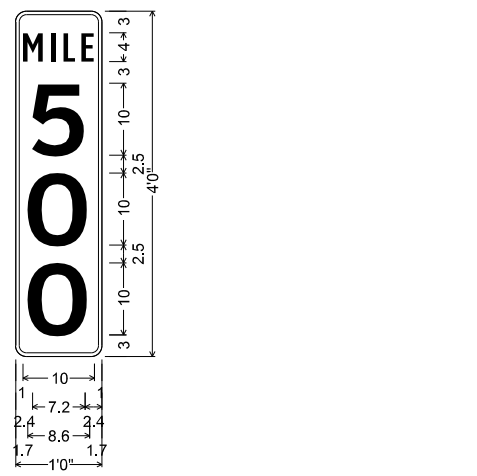

D10-3 10in;
1.5" Radius, 0.5" Border, White on Green;
"MILE", ClearviewHwy-2-W;
"5", ClearviewHwy-6-W;
"0", ClearviewHwy-6-W;
"0", ClearviewHwy-6-W;

SHEET 86 SIGN 1
SHEET 86 SIGN 2

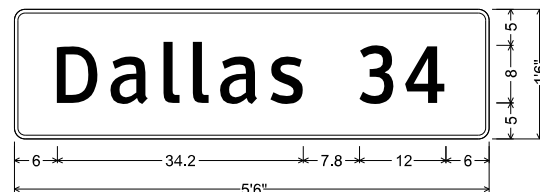

D2-1 8in;
1.5" Radius, 0.5" Border, White on Green;
"Dallas", ClearviewHwy-3-W; "34", ClearviewHwy-3-W;

SHEET 87 SIGN 1

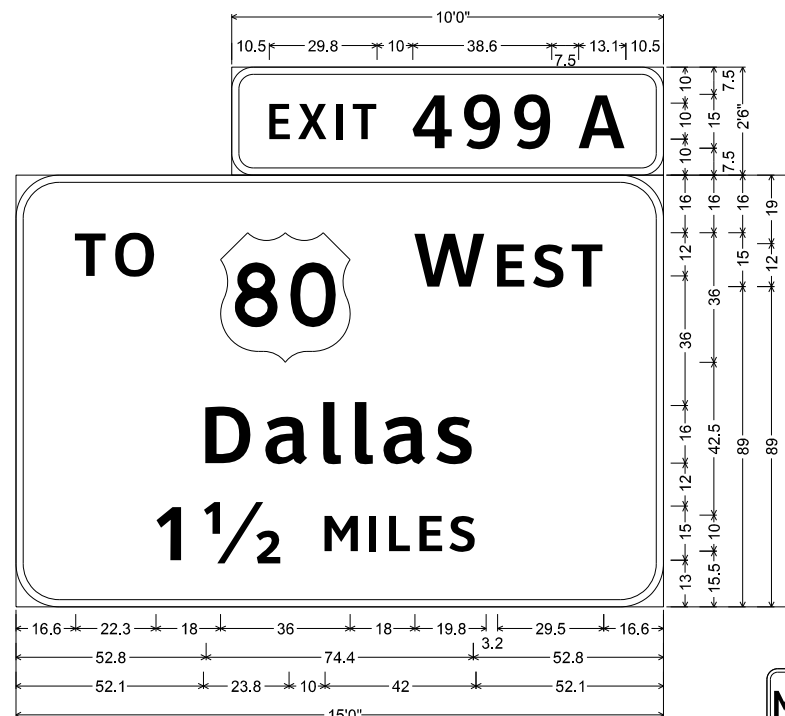

6.0" Radius, 2.0" Border, White on Green;
"EXIT", ClearviewHwy-4-W; "499", ClearviewHwy-4-W; "A", ClearviewHwy-4-W;

12.0" Radius, 2.0" Border, White on Green;
"TO", ClearviewHwy-5-W-R; US 80 M1-4;
"W" ClearviewHwy-5-W-R " " "ClearviewHwy-5-W "EST", ClearviewHwy-5-W-R;
"Dallas", ClearviewHwy-5-W-R; "1/2", ClearviewHwy-5-W-R;
"MILES", ClearviewHwy-5-W-R;

SHEET 87 SIGN 2

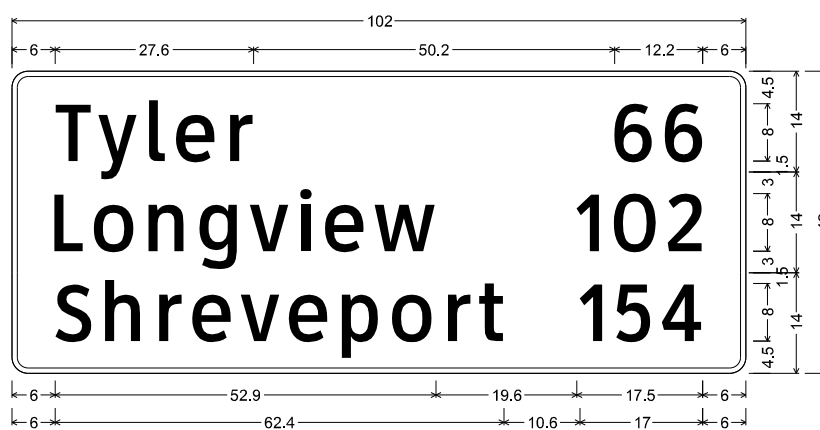

D2-3 8in;
2.3" Radius, 0.8" Border, White on Green;
"Tyler", ClearviewHwy-3-W; "66", ClearviewHwy-3-W;

2.3" Radius, 0.8" Border, White on Green;
"Longview", ClearviewHwy-3-W; "102", ClearviewHwy-3-W;

2.3" Radius, 0.8" Border, White on Green;
"Shreveport", ClearviewHwy-3-W; "154", ClearviewHwy-3-W;

SHEET 87 SIGN 4

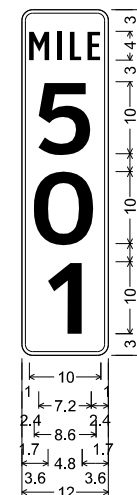

D10-3 10in;
1.5" Radius, 0.5" Border, White on Green;
"MILE", ClearviewHwy-2-W;
"5", ClearviewHwy-6-W;
"0", ClearviewHwy-6-W;
"1", ClearviewHwy-6-W;

SHEET 88 SIGN 1
SHEET 88 SIGN 2

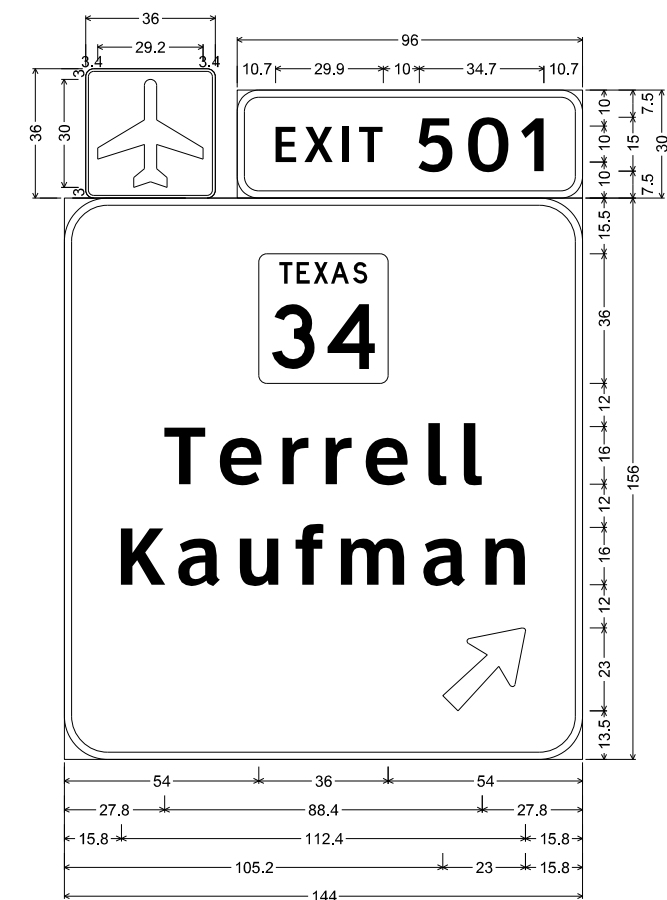

I-5_36x36;
2.3" Radius, 0.8" Border, White on Green;
Symbol I-5;

6.0" Radius, 2.0" Border, White on Green;
"EXIT", ClearviewHwy-4-W; "501", ClearviewHwy-4-W;

12.0" Radius, 2.0" Border, White on Green;
State Highway 34 M1-6T2; "Terrell", ClearviewHwy-5-W;
"Kaufman", ClearviewHwy-5-W; Arrow A-2 - 29.3" 45°;

SHEET 87 SIGN 5
SHEET 89 SIGN 2

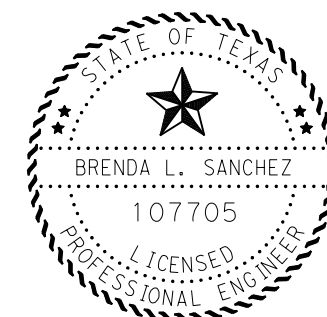

Brenda L Sanchez, P.E. 03/20/23
Signature of Registrant & Date

 Texas Department of Transportation © 2023			
GUIDE SIGN DETAILS			
SCALE: NTS		SHEET 38 OF 47	
DESIGN/CK BLS	FED. RD. DIV. NO. 6	STATE PROJECT NO. (SEE TITLE SHEET)	HIGHWAY NO. IH 20
CHECK BLS	STATE	DISTRICT	COUNTY SHEET NO.
CHECK MA	TEXAS	DAL	VARIOUS
CHECK BA	CONTROL	SECTION	JOB
	0095	14	033, ETC
			263

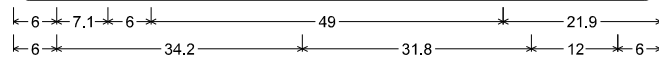

D1-3 8in UP-UP-RT;
2.3" Radius, 0.8" Border, White on Green;
Standard Arrow Custom 10.0" X 7.1" 90°; "Shreveport", ClearviewHwy-3-W;
2.3" Radius, 0.8" Border, White on Green;
Standard Arrow Custom 10.0" X 7.1" 90°; "Kaufman", ClearviewHwy-3-W;
2.3" Radius, 0.8" Border, White on Green;
"Dallas", ClearviewHwy-3-W; Standard Arrow Custom 12.0" X 7.1" 0°;

SHEET 88 SIGN 3

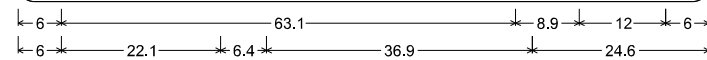
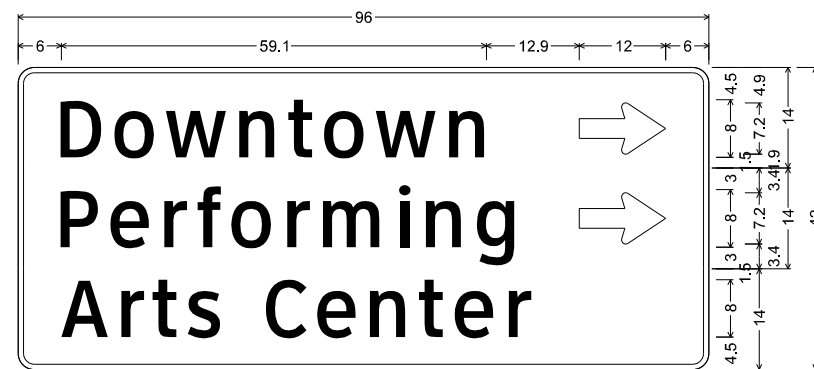

D1-3 8in RT-RT-RT;
2.3" Radius, 0.8" Border, White on Brown;
"Downtown", ClearviewHwy-3-W; Standard Arrow Custom 12.0" X 7.1" 0°;
2.3" Radius, 0.8" Border, White on Brown;
"Performing", ClearviewHwy-3-W; Standard Arrow Custom 12.0" X 7.1" 0°;
2.3" Radius, 0.8" Border, White on Brown;
"Arts Center", ClearviewHwy-3-W;

SHEET 88 SIGN 5

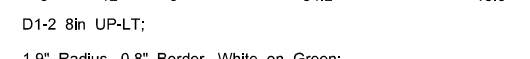
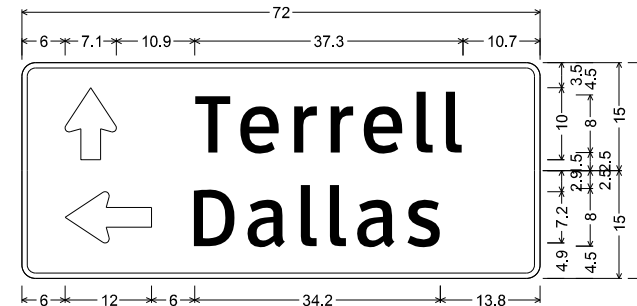

D1-2 8in UP-LT;
1.9" Radius, 0.8" Border, White on Green;
Standard Arrow Custom 10.0" X 7.1" 90°;
"Terrell", ClearviewHwy-3-W;
1.9" Radius, 0.8" Border, White on Green;
Standard Arrow Custom 12.0" X 7.1" 180°;
"Dallas", ClearviewHwy-3-W;

SHEET 88 SIGN 6

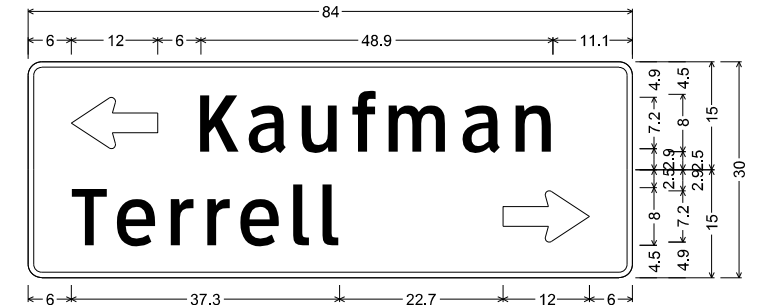

D1-2 8in LT-RT;
1.9" Radius, 0.8" Border, White on Green;
Standard Arrow Custom 12.0" X 7.1" 180°; "Kaufman", ClearviewHwy-3-W;
1.9" Radius, 0.8" Border, White on Green;
"Terrell", ClearviewHwy-3-W; Standard Arrow Custom 12.0" X 7.1" 0°;

SHEET 88 SIGN 7



D1-2 8in UP-LT;
1.9" Radius, 0.8" Border, White on Green;
Standard Arrow Custom 10.0" X 7.1" 90°; "Kaufman", ClearviewHwy-3-W;
1.9" Radius, 0.8" Border, White on Green;
Standard Arrow Custom 12.0" X 7.1" 180°; "Shreveport", ClearviewHwy-3-W;

SHEET 88 SIGN 8

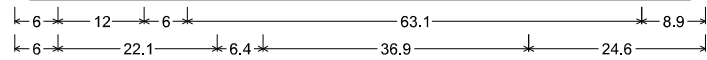
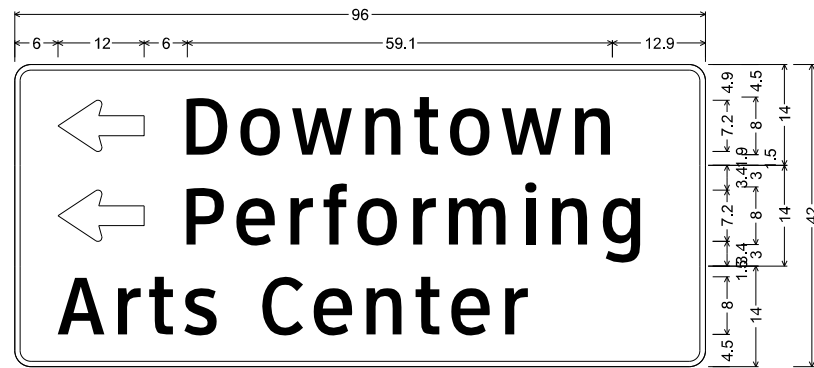

D1-3 8in LT-LT-RT;
2.3" Radius, 0.8" Border, White on Brown;
Standard Arrow Custom 12.0" X 7.1" 180°; "Downtown", ClearviewHwy-3-W;
2.3" Radius, 0.8" Border, White on Brown;
Standard Arrow Custom 12.0" X 7.1" 180°; "Performing", ClearviewHwy-3-W;
2.3" Radius, 0.8" Border, White on Brown;
"Arts Center", ClearviewHwy-3-W;

SHEET 88 SIGN 9

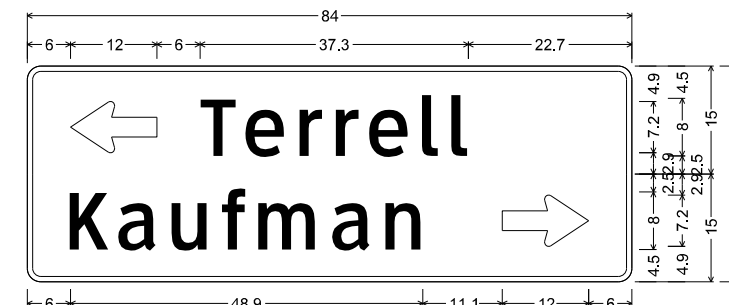

D1-2 8in LT-RT;
1.9" Radius, 0.8" Border, White on Green;
Standard Arrow Custom 12.0" X 7.1" 180°; "Terrell", ClearviewHwy-3-W;
1.9" Radius, 0.8" Border, White on Green;
"Kaufman", ClearviewHwy-3-W; Standard Arrow Custom 12.0" X 7.1" 0°;

SHEET 88 SIGN 10

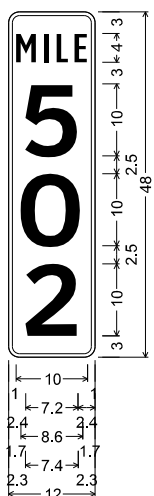

D10-3 10in;
1.5" Radius, 0.5" Border, White on Green;
"MILE", ClearviewHwy-2-W;
"5", ClearviewHwy-6-W;
"0", ClearviewHwy-6-W;
"2", ClearviewHwy-6-W;

SHEET 90 SIGN 1
SHEET 90 SIGN 2

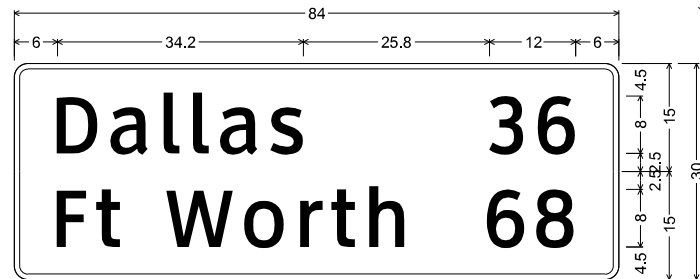

D2-2 8in;
1.9" Radius, 0.8" Border, White on Green;
"Dallas", ClearviewHwy-3-W; "36", ClearviewHwy-3-W;
1.9" Radius, 0.8" Border, White on Green;
"Ft Worth", ClearviewHwy-3-W; "68", ClearviewHwy-3-W;

SHEET 90 SIGN 3

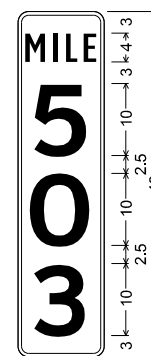

D10-3 10in;
1.5" Radius, 0.5" Border, White on Green;
"MILE", ClearviewHwy-2-W;
"5", ClearviewHwy-6-W;
"0", ClearviewHwy-6-W;
"3", ClearviewHwy-6-W;

SHEET 91 SIGN 1
SHEET 91 SIGN 2

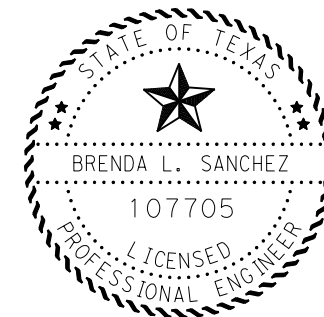

Brenda L Sanchez, P.E. 03/20/23
Signature of Registrant & Date

© 2023			
GUIDE SIGN DETAILS			
SCALE: NTS		SHEET 39 OF 47	
DESIGN/CK BLS	FED. RD. DIV. NO. 6	STATE PROJECT NO. (SEE TITLE SHEET)	HIGHWAY NO. IH 20
CHECK BLS	STATE	DISTRICT	COUNTY
CHECK MA	TEXAS	DAL	VARIOUS
CHECK BA	CONTROL	SECTION	JOB
	0095	14	033, ETC
			264

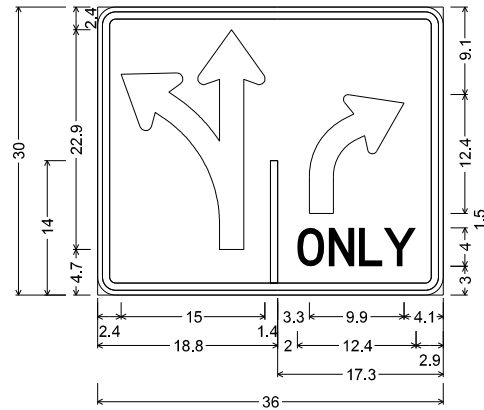

R3-8L3AR_48x30;
 1.9" Radius, 0.8" Border, 0.5" Indent, LaneMarker height: 12
 LaneMarker width: 0.8Black on White;
 M lr=13.25, s=2.5;
 1.9" Radius, 0.8" Border, 0.5" Indent, Black on White;
 L lr=4.25, s=2.5; "ONLY", D 50% spacing;

SHEET 92 SIGN 2

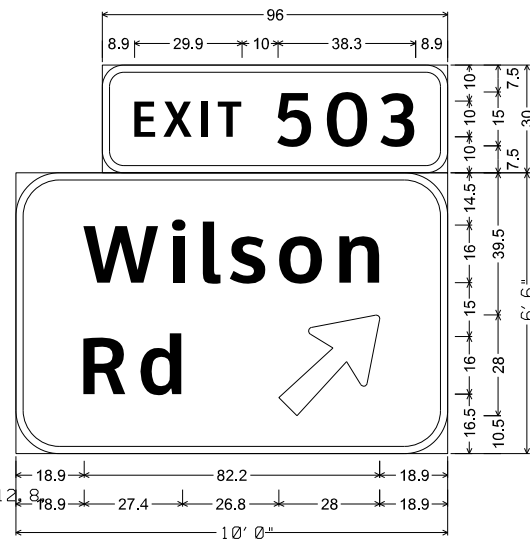

6.0" Radius, 2.0" Border, White on Green;
 "EXIT", ClearviewHwy-4-W; "503", ClearviewHwy-4-W;
 12.0" Radius, 2.0" Border, White on Green;
 "Wilson", ClearviewHwy-5-W-R;
 "Rd", ClearviewHwy-5-W-R; Arrow A-3 - 35.6" 45";

SHEET 93 SIGN 1

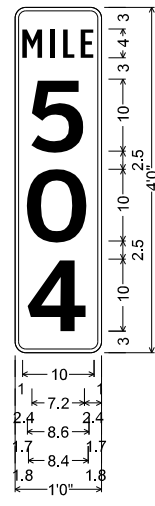

D10-3 10in;
 1.5" Radius, 0.5" Border, White on Green;
 "MILE", ClearviewHwy-2-W;
 "5", ClearviewHwy-6-W;
 "0", ClearviewHwy-6-W;
 "4", ClearviewHwy-6-W;

SHEET 93 SIGN 2
 SHEET 93 SIGN 3

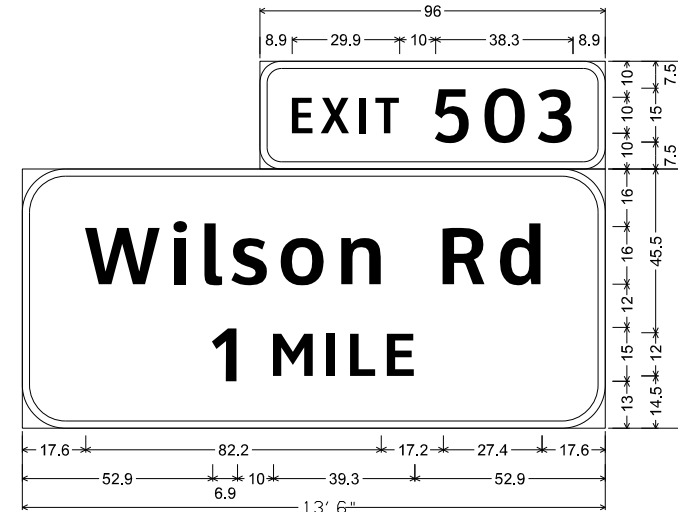

6.0" Radius, 2.0" Border, White on Green;
 "EXIT", ClearviewHwy-4-W; "503", ClearviewHwy-4-W;
 12.0" Radius, 2.0" Border, White on Green;
 "Wilson Rd", ClearviewHwy-5-W-R; "1", ClearviewHwy-5-W-R;
 "MILE", ClearviewHwy-5-W-R;

SHEET 94 SIGN 1

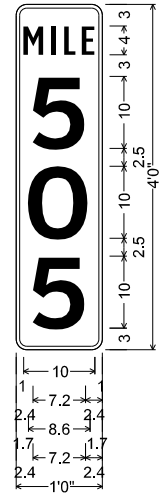

D10-3 10in;
 1.5" Radius, 0.5" Border, White on Green;
 "MILE", ClearviewHwy-2-W;
 "5", ClearviewHwy-6-W;
 "0", ClearviewHwy-6-W;
 "5", ClearviewHwy-6-W;

SHEET 95 SIGN 1
 SHEET 95 SIGN 2

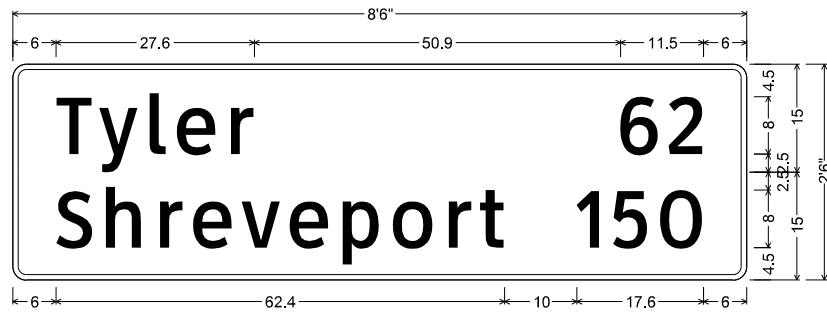

D2-2 8in;
 1.9" Radius, 0.8" Border, White on Green;
 "Tyler", ClearviewHwy-3-W; "62", ClearviewHwy-3-W;
 1.9" Radius, 0.8" Border, White on Green;
 "Shreveport", ClearviewHwy-3-W; "150", ClearviewHwy-3-W;

SHEET 94 SIGN 2

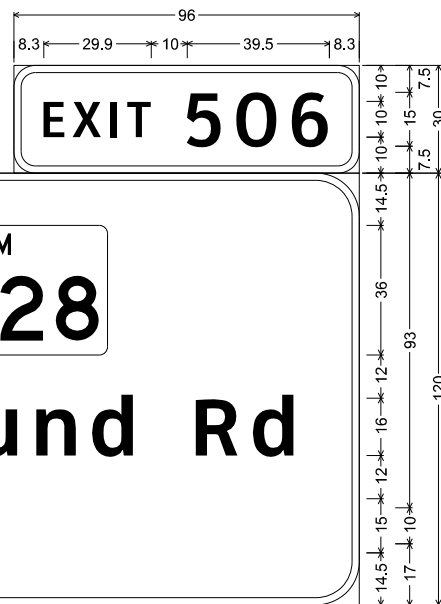

6.0" Radius, 2.0" Border, White on Green;
 "EXIT", ClearviewHwy-4-W; "506", ClearviewHwy-4-W;
 12.0" Radius, 2.0" Border, White on Green;
 State Highway 429 M1-6F3; State Highway 2728 M1-6F4; "College Mound Rd", ClearviewHwy-5-W-R;
 "1", ClearviewHwy-5-W-R; "MILE", ClearviewHwy-5-W-R;

SHEET 95 SIGN 3
 SHEET 99 SIGN 3

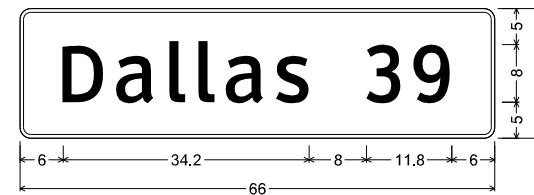

D2-1 8in;
 1.5" Radius, 0.5" Border, White on Green;
 "Dallas", ClearviewHwy-3-W; "39", ClearviewHwy-3-W;

SHEET 96 SIGN 1

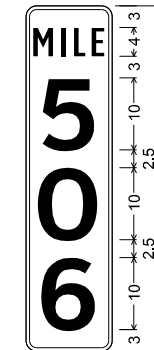

D10-3 10in;
 1.5" Radius, 0.5" Border, White on Green;
 "MILE", ClearviewHwy-2-W;
 "5", ClearviewHwy-6-W;
 "0", ClearviewHwy-6-W;
 "6", ClearviewHwy-6-W;

SHEET 97 SIGN 2
 SHEET 97 SIGN 3

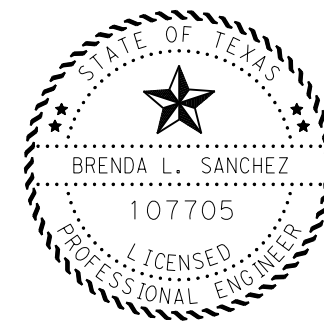

Brenda L Sanchez, P.E. 03/20/23
 Signature of Registrant & Date



GUIDE SIGN DETAILS

SCALE: NTS SHEET 40 OF 47

DESIGN/CK BLS	FED. RD. DIV. NO. 6	STATE PROJECT NO. (SEE TITLE SHEET)		HIGHWAY NO. IH 20
CHECK BLS	STATE	DISTRICT DAL	COUNTY VARIOUS	SHEET NO. 265
CHECK MA	TEXAS	SECTION 0095	JOB 14	265
CHECK BA	CONTROL	SECTION 033, ETC	JOB	

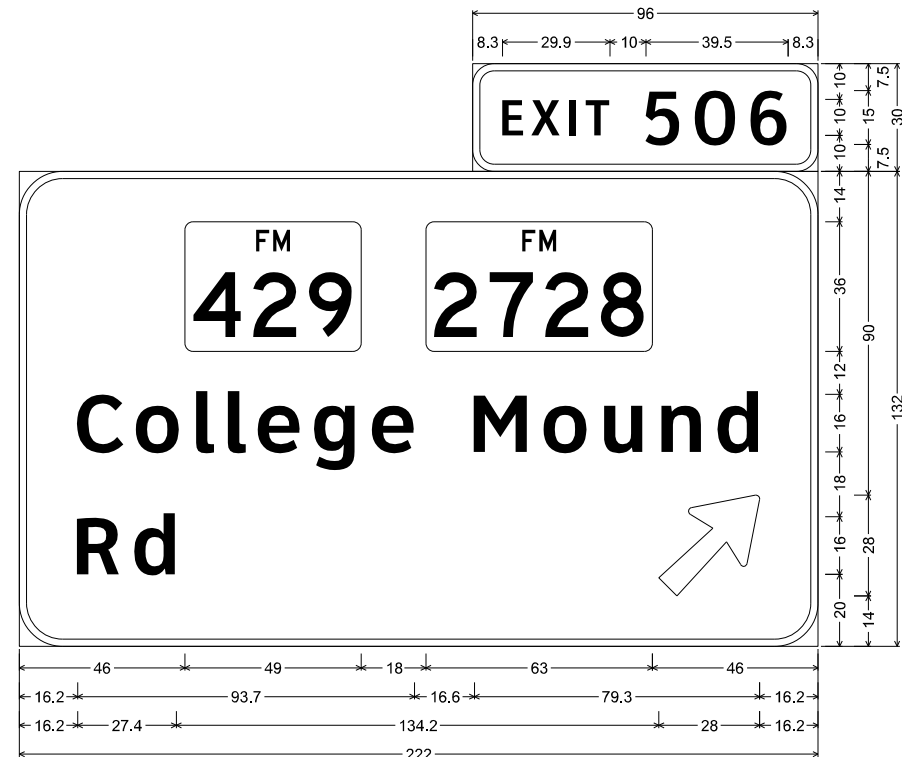

6.0" Radius, 2.0" Border, White on Green;
 "EXIT", ClearviewHwy-4-W; "506", ClearviewHwy-4-W;

12.0" Radius, 2.0" Border, White on Green;
 State Highway 429 M1-6F3; State Highway 2728 M1-6F4; "College Mound", ClearviewHwy-5-W-R;
 "Rd", ClearviewHwy-5-W-R; Arrow A-3 - 35.6" 45";

SHEET 98 SIGN 2

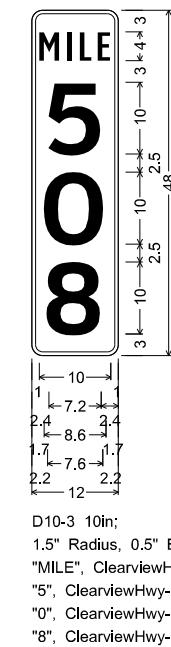

D10-3 10in;
 1.5" Radius, 0.5" Border, White on Green;
 "MILE", ClearviewHwy-2-W;
 "5", ClearviewHwy-6-W;
 "0", ClearviewHwy-6-W;
 "8", ClearviewHwy-6-W;

SHEET 101 SIGN 1
SHEET 101 SIGN 2

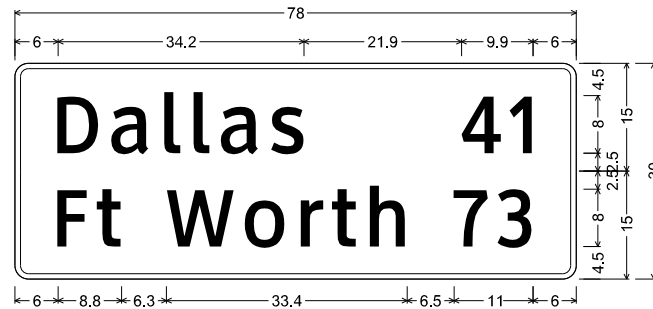

D2-2 8in;
 1.9" Radius, 0.8" Border, White on Green;
 "Dallas", ClearviewHwy-3-W; "41", ClearviewHwy-3-W;

1.9" Radius, 0.8" Border, White on Green;
 "Ft Worth", ClearviewHwy-3-W; "73", ClearviewHwy-3-W;

SHEET 101 SIGN 3

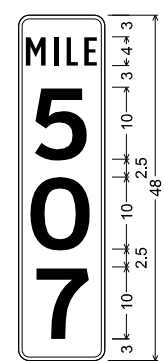

D10-3 10in;
 1.5" Radius, 0.5" Border, White on Green;
 "MILE", ClearviewHwy-2-W;
 "5", ClearviewHwy-6-W;
 "0", ClearviewHwy-6-W;
 "7", ClearviewHwy-6-W;

SHEET 99 SIGN 1
SHEET 99 SIGN 2

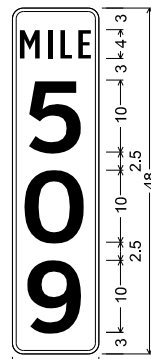

D10-3 10in;
 1.5" Radius, 0.5" Border, White on Green;
 "MILE", ClearviewHwy-2-W;
 "5", ClearviewHwy-6-W;
 "0", ClearviewHwy-6-W;
 "9", ClearviewHwy-6-W;

SHEET 103 SIGN 1
SHEET 103 SIGN 2



D2-1 8in;
 1.5" Radius, 0.5" Border, White on Green;
 "Shreveport", ClearviewHwy-3-W; "148", ClearviewHwy-3-W;

SHEET 99 SIGN 4

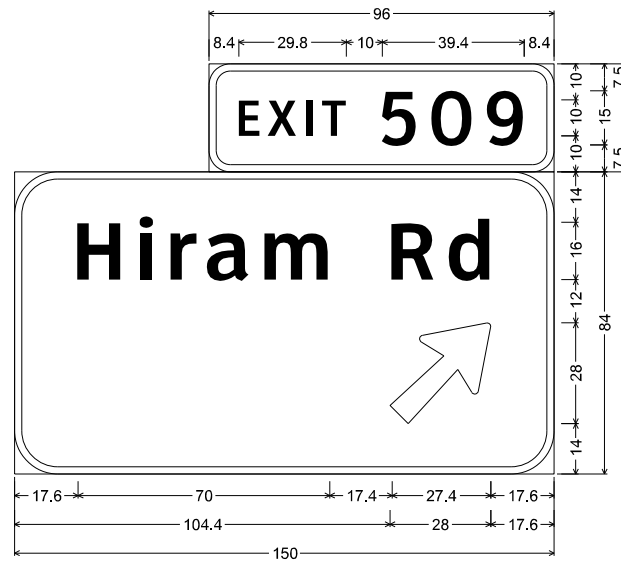

6.0" Radius, 2.0" Border, White on Green;
 "EXIT", ClearviewHwy-4-W; "509", ClearviewHwy-4-W;

12.0" Radius, 2.0" Border, White on Green;
 "Hiram Rd", ClearviewHwy-5-W-R; Arrow A-3 - 35.6" 45";

SHEET 103 SIGN 4

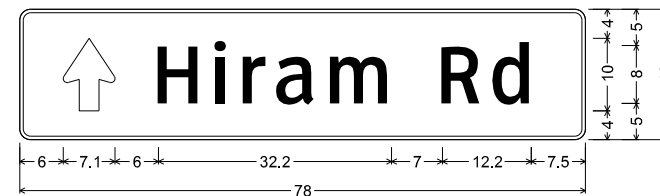

D1-1 8in UP;
 1.5" Radius, 0.5" Border, White on Green;
 Standard Arrow Custom 10.0" X 7.1" 90°;
 "Hiram Rd", ClearviewHwy-3-W;

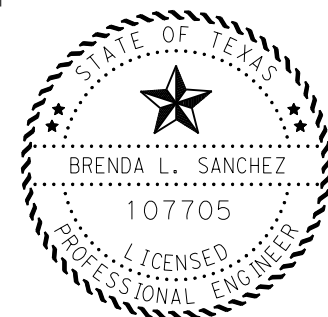

Brenda L Sanchez, P.E. 03/20/23
 Signature of Registrant & Date

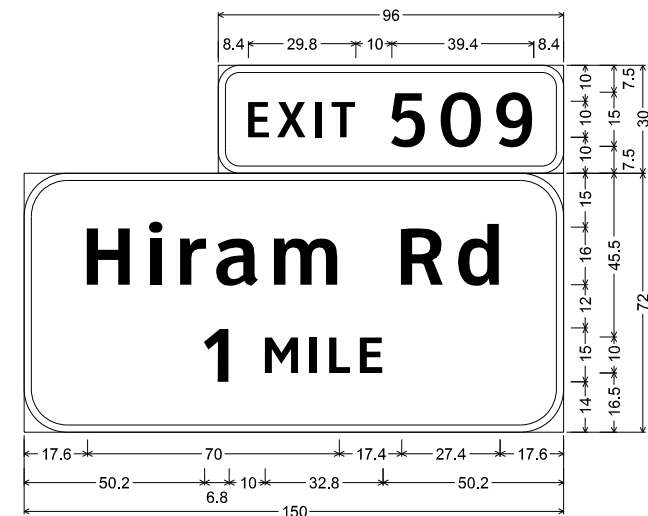

6.0" Radius, 2.0" Border, White on Green;
 "EXIT", ClearviewHwy-4-W; "509", ClearviewHwy-4-W;

12.0" Radius, 2.0" Border, White on Green;
 "Hiram Rd", ClearviewHwy-5-W-R; "1", ClearviewHwy-5-W-R;
 "MILE", ClearviewHwy-5-W-R;

SHEET 100 SIGN 1
SHEET 105 SIGN 3

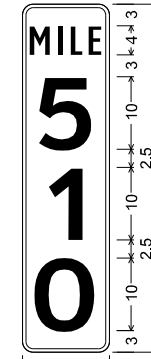

D10-3 10in;
 1.5" Radius, 0.5" Border, White on Green;
 "MILE", ClearviewHwy-2-W;
 "5", ClearviewHwy-6-W;
 "1", ClearviewHwy-6-W;
 "0", ClearviewHwy-6-W;

SHEET 105 SIGN 1
SHEET 105 SIGN 2

Texas Department of Transportation ©2023			
GUIDE SIGN DETAILS			
SCALE: NTS		SHEET 41 OF 47	
DESIGN/CK BLS	FED. RD. DIV. NO. 6	STATE PROJECT NO. (SEE TITLE SHEET)	HIGHWAY NO. IH 20
CHECK BLS	STATE	DISTRICT DAL	COUNTY VARIOUS
CHECK MA	TEXAS	SECTION	JOB
CHECK BA	0095	14	033, ETC
			266

3/17/2023 3:50:18 PM

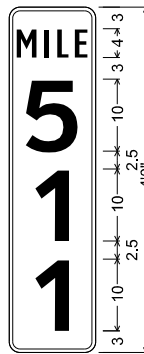

D10-3 10in;
1.5" Radius, 0.5" Border, White on Green;
"MILE", ClearviewHwy-2-W;
"5", ClearviewHwy-6-W;
"1", ClearviewHwy-6-W;
"1", ClearviewHwy-6-W;

SHEET 107 SIGN 1
SHEET 107 SIGN 2



6.0" Radius, 2.0" Border, White on Green;
"EXIT", ClearviewHwy-4-W;
"512", ClearviewHwy-4-W;

12.0" Radius, 2.0" Border, White on Green;
State Highway 2965 M1-6F4;
"1", ClearviewHwy-5-W-R;
"MILE", ClearviewHwy-5-W-R;

SHEET 107 SIGN 3

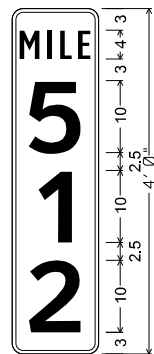

D10-3 10in;
1.5" Radius, 0.5" Border, White on Green;
"MILE", ClearviewHwy-2-W;
"5", ClearviewHwy-6-W;
"1", ClearviewHwy-6-W;
"2", ClearviewHwy-6-W;

SHEET 108 SIGN 1
SHEET 109 SIGN 4

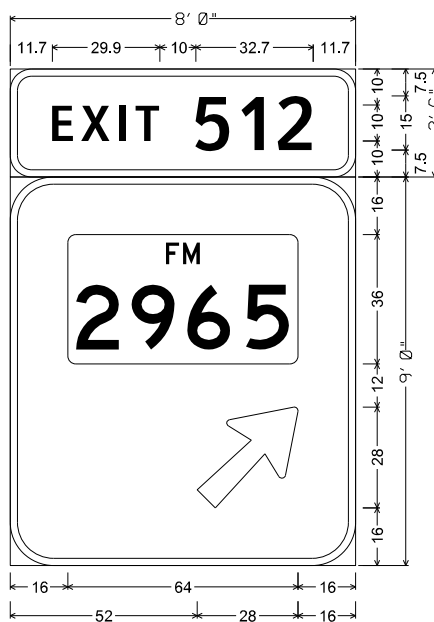

6.0" Radius, 2.0" Border, White on Green;
"EXIT", ClearviewHwy-4-W;
"512", ClearviewHwy-4-W;

12.0" Radius, 2.0" Border, White on Green;
State Highway 2965 M1-6F4;
Arrow A-3 - 35.6" 45";

SHEET 108 SIGN 2
SHEET 110 SIGN 1

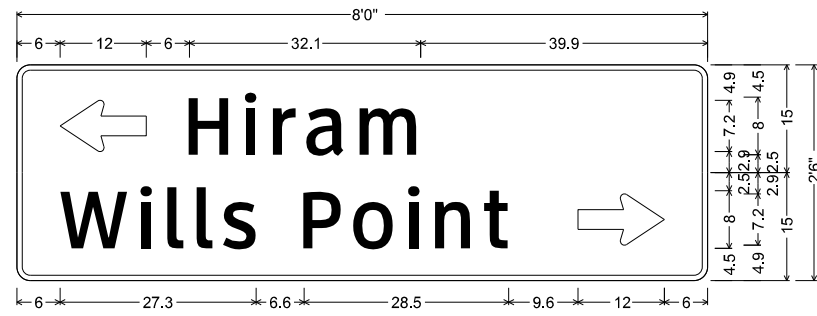

D1-2 8in LT-RT;
1.9" Radius, 0.8" Border, White on Green;
Standard Arrow Custom 12.0" X 7.1" 180"; "Hiram", ClearviewHwy-3-W;
1.9" Radius, 0.8" Border, White on Green;
"Wills Point", ClearviewHwy-3-W; Standard Arrow Custom 12.0" X 7.1" 0°;

SHEET 109 SIGN 2

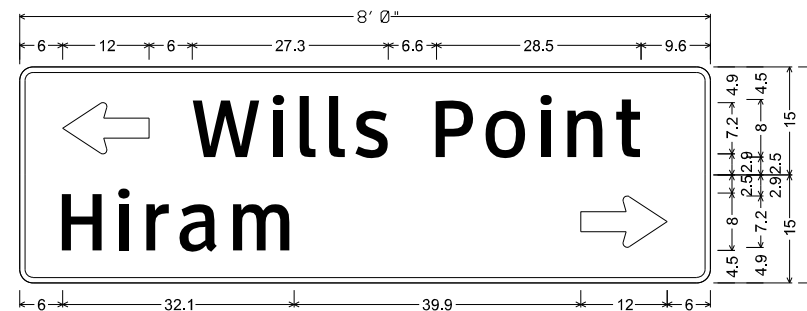

D1-2 8in LT-RT;
1.9" Radius, 0.8" Border, White on Green;
Standard Arrow Custom 12.0" X 7.1" 180"; "Wills Point", ClearviewHwy-3-W;
1.9" Radius, 0.8" Border, White on Green;
"Hiram", ClearviewHwy-3-W; Standard Arrow Custom 12.0" X 7.1" 0°;

SHEET 109 SIGN 5

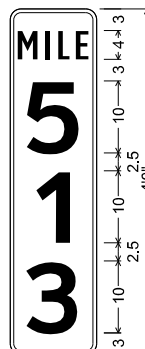

D10-3 10in;
1.5" Radius, 0.5" Border, White on Green;
"MILE", ClearviewHwy-2-W;
"5", ClearviewHwy-6-W;
"1", ClearviewHwy-6-W;
"3", ClearviewHwy-6-W;

SHEET 110 SIGN 2
SHEET 110 SIGN 3

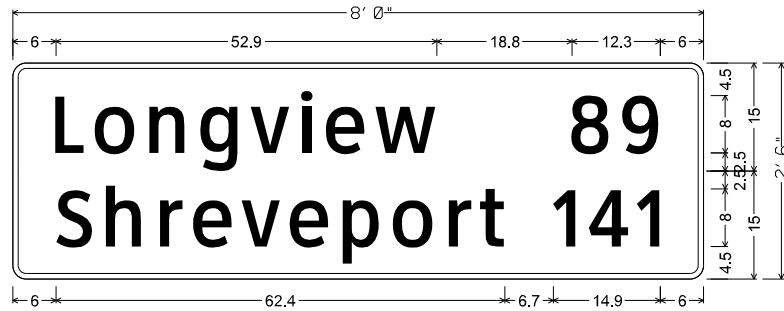

D2-2 8in;
1.9" Radius, 0.8" Border, White on Green;
"Longview", ClearviewHwy-3-W; "89", ClearviewHwy-3-W;
1.9" Radius, 0.8" Border, White on Green;
"Shreveport", ClearviewHwy-3-W; "141", ClearviewHwy-3-W;

SHEET 110 SIGN 4

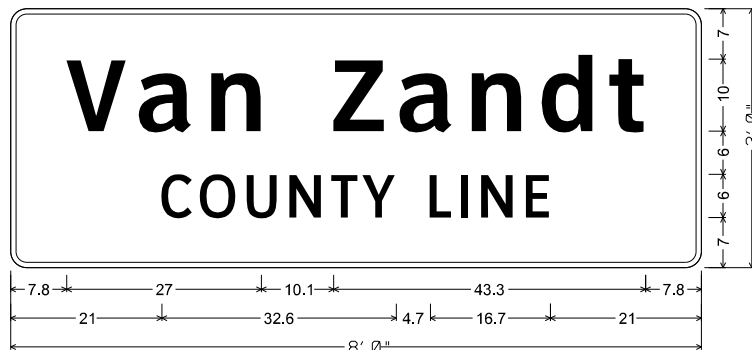

I-2dT 10in;
2.3" Radius, 0.8" Border, White on Green;
"Van Zandt", ClearviewHwy-5-W-R; "COUNTY LINE", ClearviewHwy-3-W;

SHEET 111 SIGN 2

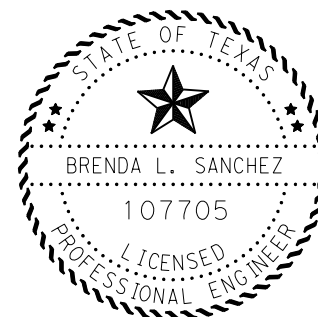

Brenda L Sanchez, P.E. 03/20/23
Signature of Registrant & Date



GUIDE SIGN DETAILS

SCALE: NTS SHEET 42 OF 47

DESIGN/CK	FED. RD. DIV. NO.	STATE PROJECT NO.		HIGHWAY NO.
BLS	6	(SEE TITLE SHEET)		IH 20
BLS	STATE	DISTRICT	COUNTY	SHEET NO.
MA	TEXAS	DAL	VARIOUS	267
CK	CONTROL	SECTION	JOB	
BA	0095	14	033, ETC	

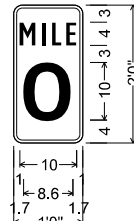

D10-3 10in;
1.5" Radius, 0.5" Border, White on Green;
"MILE", ClearviewHwy-2-W;
"0", ClearviewHwy-6-W;

SHEET 112 SIGN 1
SHEET 112 SIGN 13



D1-2 8in LT-LT;
1.9" Radius, 0.8" Border, White on Green;
"Hickory Tree", ClearviewHwy-3-W;
1.9" Radius, 0.8" Border, White on Green;
Standard Arrow Custom 12.0" X 7.1" 180°;
"Rd", ClearviewHwy-3-W;

SHEET 112 SIGN 2



D1-2 8in RT-RT;
1.9" Radius, 0.8" Border, White on Green;
"Hickory Tree", ClearviewHwy-3-W;
1.9" Radius, 0.8" Border, White on Green;
"Rd", ClearviewHwy-3-W;
Standard Arrow Custom 12.0" X 7.1" 0°;

SHEET 112 SIGN 3

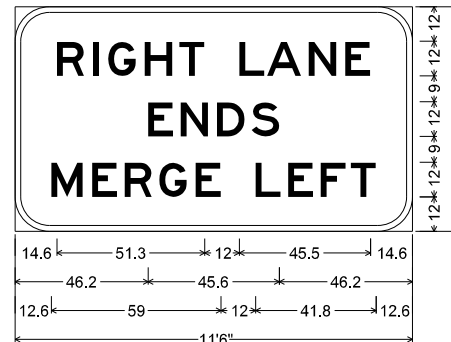

E21-2T_120x60;
2.0" Border, Black on Yellow;
"RIGHT LANE", E; "ENDS", E;
"MERGE LEFT", E;

SHEET 112 SIGN 7

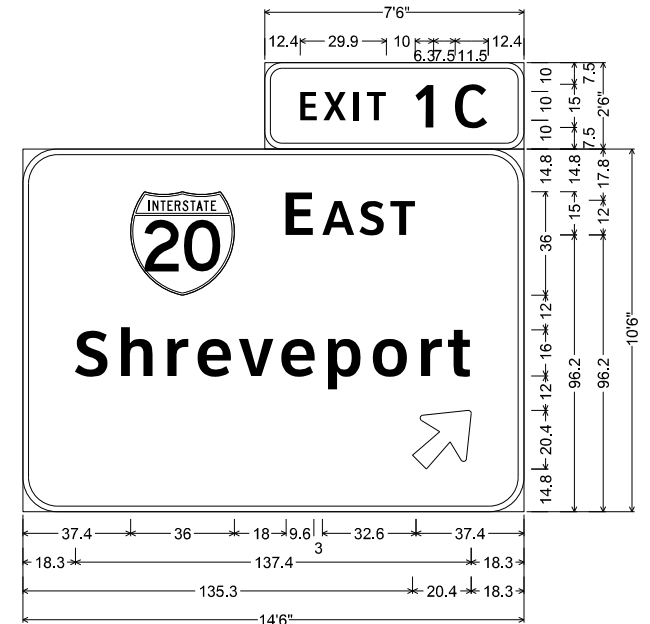

6.0" Radius, 2.0" Border, White on Green;
"EXIT", ClearviewHwy-4-W; "1", ClearviewHwy-4-W;
"C", ClearviewHwy-4-W;

12.0" Radius, 2.0" Border, White on Green;
Interstate 20 M1-1; "E AST", ClearviewHwy-5-W-R;
"Shreveport", ClearviewHwy-5-W-R; Arrow B-3 - 25.0° 45°;

SHEET 112 SIGN 8

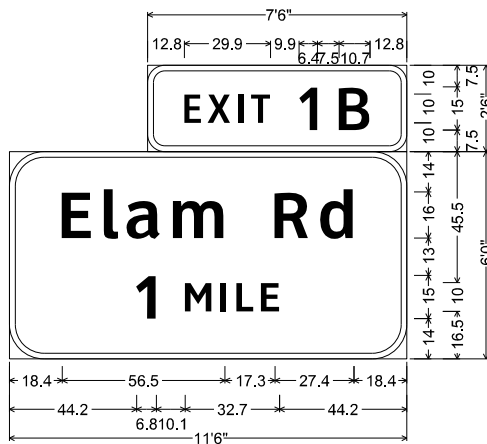

6.0" Radius, 2.0" Border, White on Green;
"EXIT 1 B", ClearviewHwy-4-W;
12.0" Radius, 2.0" Border, White on Green;
"Elam Rd", ClearviewHwy-5-W-R;
"1 MILE", ClearviewHwy-5-W-R;

SHEET 112 SIGN 11

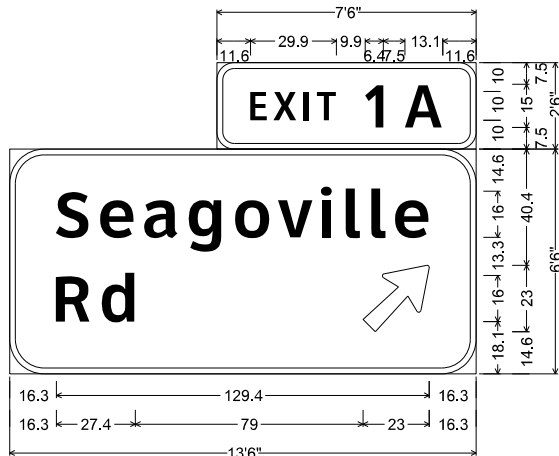

6.0" Radius, 2.0" Border, White on Green;
"EXIT 1 A", ClearviewHwy-4-W;
12.0" Radius, 2.0" Border, White on Green;
"Seagoville", ClearviewHwy-5-W-R;
"Rd", ClearviewHwy-5-W-R; Arrow A-2 - 29.3° 45°;

SHEET 112 SIGN 12
SHEET 113 SIGN 5

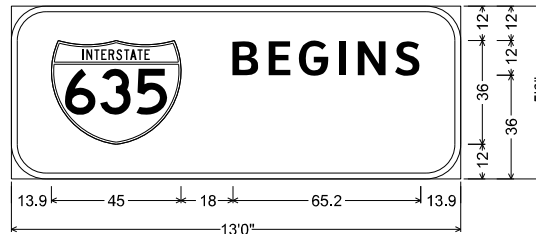

12.0" Radius, 2.0" Border, White on Green;
Interstate 635 M1-1 16.0" D;
"BEGINS", ClearviewHwy-5-W-R;

SHEET 112 SIGN 14

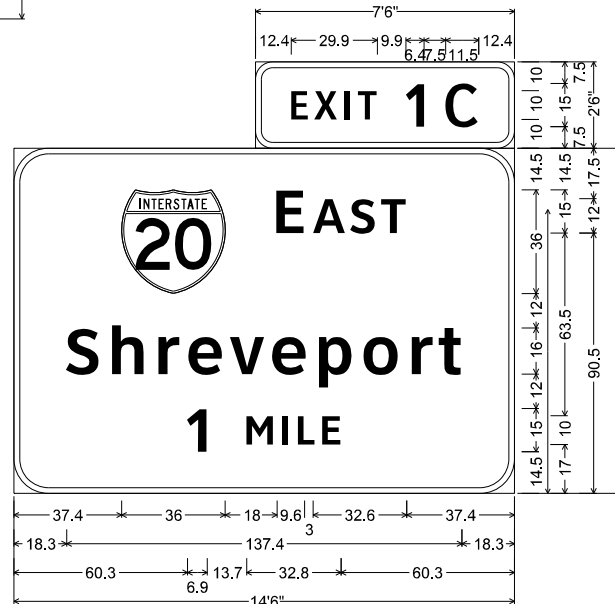

6.0" Radius, 2.0" Border, White on Green;
"EXIT 1 C", ClearviewHwy-4-W;

12.0" Radius, 2.0" Border, White on Green;
Interstate 20 M1-1; "E AST", ClearviewHwy-5-W-R;
"Shreveport", ClearviewHwy-5-W-R;
"1 MILE", ClearviewHwy-5-W-R;

SHEET 113 SIGN 4

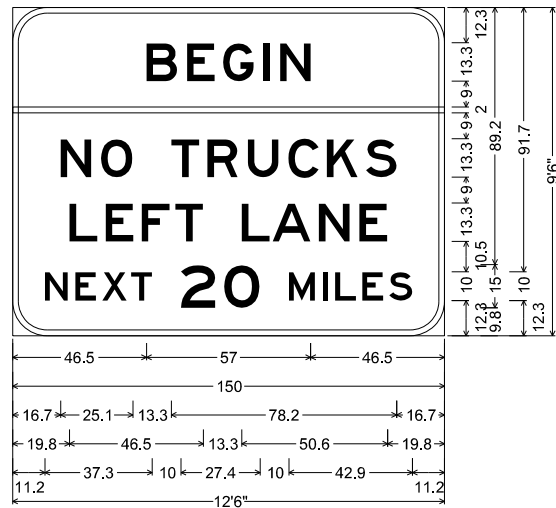

12.0" Radius, 2.0" Border, Black on White;
"BEGIN", E; "NO TRUCKS", E; "LEFT LANE", E;
"NEXT 20 MILES", E;

SHEET 113 SIGN 1

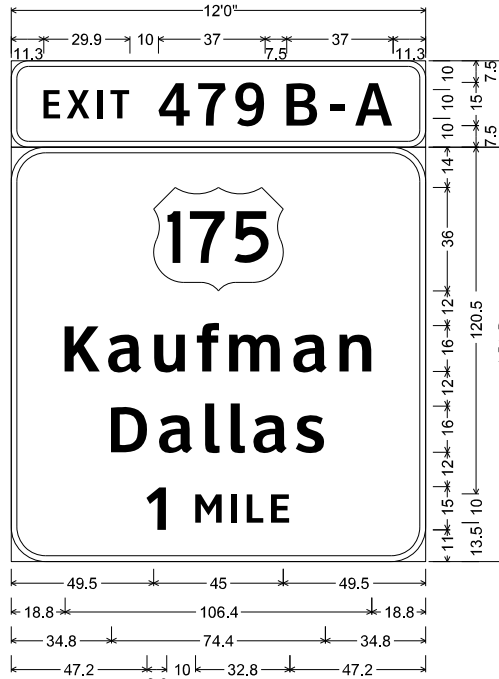

6.0" Radius, 2.0" Border, White on Green;
"EXIT", ClearviewHwy-4-W;
"479", ClearviewHwy-4-W; "B-A", ClearviewHwy-4-W;

E1-1a_VARx150;
12.0" Radius, 2.0" Border, White on Green;
US 175 M1-4; "Kaufman", ClearviewHwy-5-W-R;
"Dallas", ClearviewHwy-5-W-R;
"1", ClearviewHwy-5-W-R;
"MILE", ClearviewHwy-5-W-R;

SHEET 113 SIGN 3

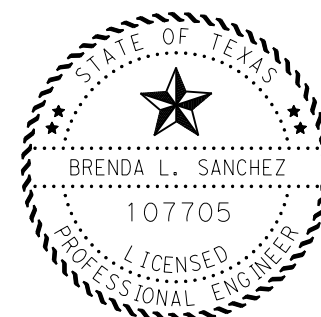

Brenda L. Sanchez, P.E. 03/20/23
Signature of Registrant & Date

Texas Department of Transportation ©2023

GUIDE SIGN DETAILS

SCALE: NTS SHEET 43 OF 47

DESIGN/CK	FED. RD. DIV. NO.	STATE PROJECT NO.		HIGHWAY NO.
BLS	6	(SEE TITLE SHEET)		IH 20
CHECK	STATE	DISTRICT	COUNTY	SHEET NO.
BLS	TEXAS	DAL	VARIOUS	268
CHECK	CONTROL	SECTION	JOB	
MA	0095	14	033, ETC	
BA				

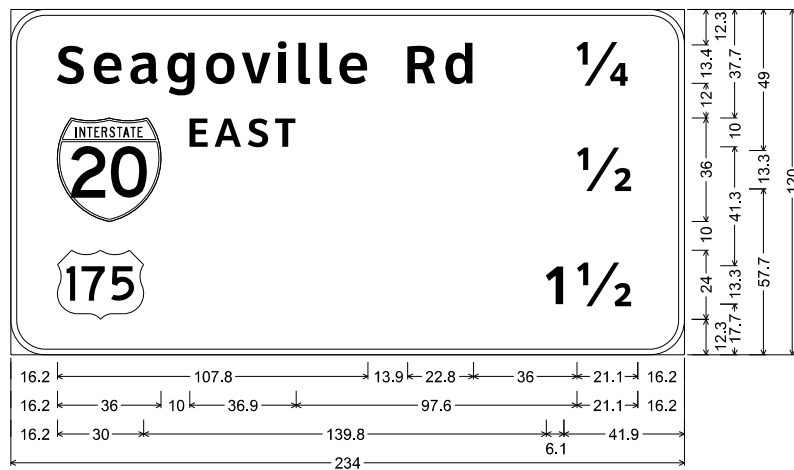

12.0" Radius, 2.0" Border, White on Green;
 "Seagoville Rd", ClearviewHwy-5-W-R; "1/4", ClearviewHwy-5-W-R; Interstate 20 M1-1;
 "EAST", ClearviewHwy-5-W; "1/2", ClearviewHwy-5-W-R; US 175 M1-4;
 "1 1/2", ClearviewHwy-5-W-R;

SHEET 113 SIGN 6

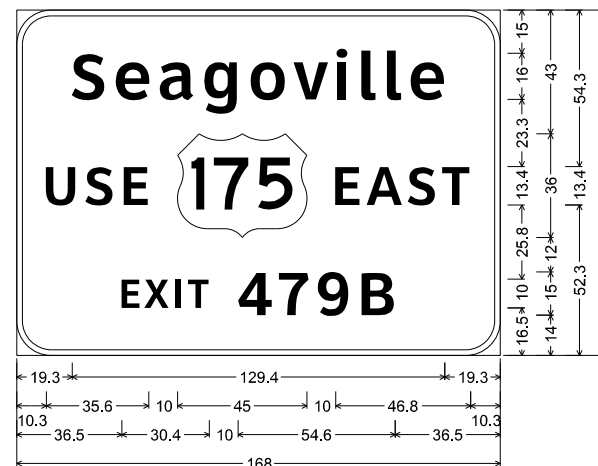

12.0" Radius, 2.0" Border, White on Green;
 "Seagoville", ClearviewHwy-5-W-R;
 "USE", ClearviewHwy-5-W-R; US 175 M1-4;
 "EAST", ClearviewHwy-5-W-R; "EXIT", ClearviewHwy-5-W-R;
 "479B", ClearviewHwy-5-W-R;

SHEET 113 SIGN 7

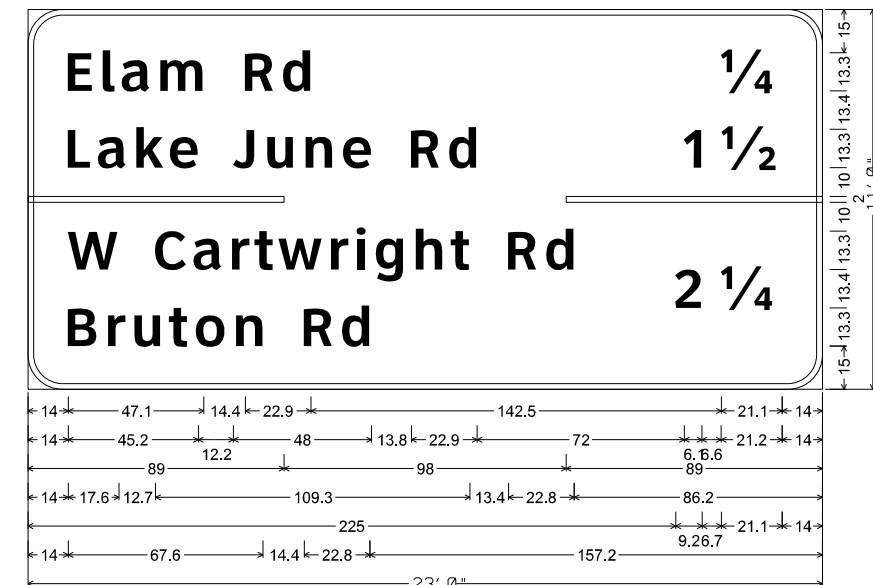

12.0" Radius, 2.0" Border, White on Green;
 "Elam Rd", ClearviewHwy-5-W-R; "1/4", ClearviewHwy-5-W-R; "Lake June Rd", ClearviewHwy-5-W-R;
 "1 1/2", ClearviewHwy-5-W-R; "W Cartwright Rd", ClearviewHwy-5-W-R; "2 1/4", ClearviewHwy-5-W-R;
 "Bruton Rd", ClearviewHwy-5-W-R;

SHEET 113 SIGN 8

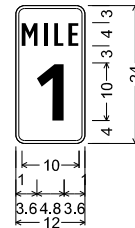

D10-3 10In;
 1.5" Radius, 0.5" Border, White on Green;
 "MILE", ClearviewHwy-2-W;
 "1", ClearviewHwy-6-W;

SHEET 114 SIGN 1
SHEET 114 SIGN 6

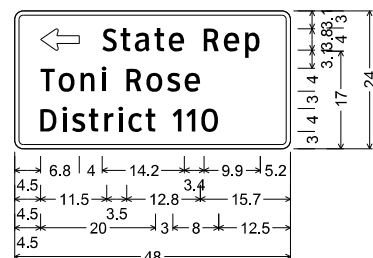

D23-1TL(3)_VARx24;
 1.5" Radius, 0.8" Border, White on Green;
 Standard Arrow Custom 6.8" X 3.7" 180°;
 "State Rep", ClearviewHwy-3-W;
 "Toni Rose", ClearviewHwy-3-W;
 "District 110", ClearviewHwy-3-W;

SHEET 114 SIGN 2

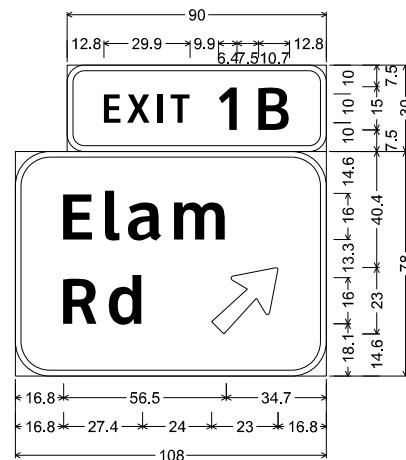

6.0" Radius, 2.0" Border, White on Green;
 "EXIT 1 B", ClearviewHwy-4-W;
 12.0" Radius, 2.0" Border, White on Green;
 "Elam", ClearviewHwy-5-W-R;
 "Rd", ClearviewHwy-5-W-R;
 Arrow A-2 - 29.3" 45°;

SHEET 114 SIGN 4

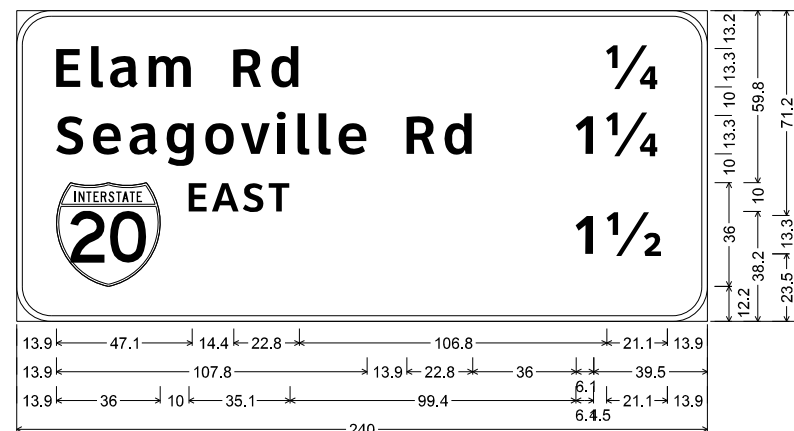

12.0" Radius, 2.0" Border, White on Green;
 "Elam Rd", ClearviewHwy-5-W-R; "1/4", ClearviewHwy-5-W-R;
 "Seagoville Rd", ClearviewHwy-5-W-R; "1 1/2", ClearviewHwy-5-W-R; Interstate 20 M1-1;
 "EAST", ClearviewHwy-5-W-R; "1 1/2", ClearviewHwy-5-W-R;

SHEET 115 SIGN 1

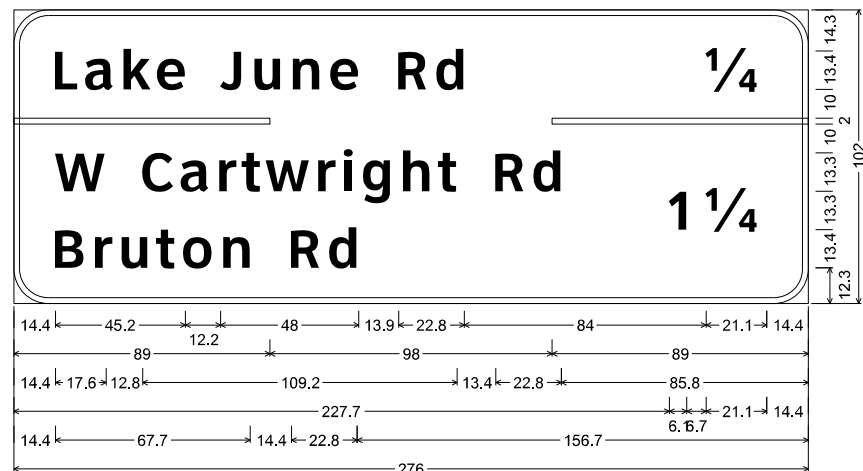

12.0" Radius, 2.0" Border, White on Green;
 "Lake June Rd", ClearviewHwy-5-W-R; "1/4", ClearviewHwy-5-W-R;
 "W Cartwright Rd", ClearviewHwy-5-W-R; "1 1/2", ClearviewHwy-5-W-R;
 "Bruton Rd", ClearviewHwy-5-W-R;

SHEET 115 SIGN 2

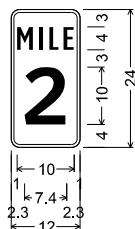

D10-3 10In;
 1.5" Radius, 0.5" Border, White on Green;
 "MILE", ClearviewHwy-2-W;
 "2", ClearviewHwy-6-W;

SHEET 116 SIGN 1
SHEET 116 SIGN 4

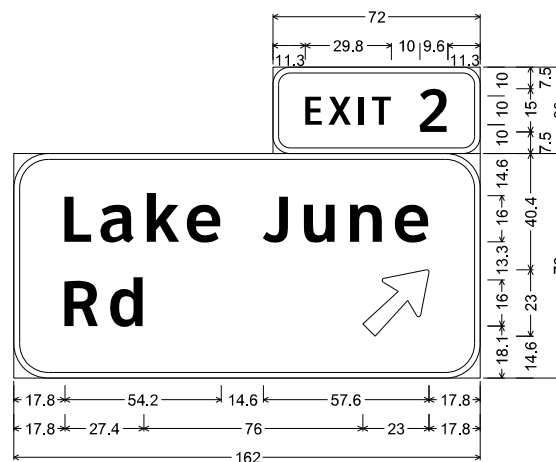

6.0" Radius, 2.0" Border, White on Green;
 "EXIT 2", ClearviewHwy-4-W;
 12.0" Radius, 2.0" Border, White on Green;
 "Lake June", ClearviewHwy-5-W-R;
 "Rd", ClearviewHwy-5-W-R; Arrow A-2 - 29.3" 45°;

SHEET 116 SIGN 3



Brenda L. Sanchez, P.E. 03/20/23
 Signature of Registrar & Date



GUIDE SIGN DETAILS

SCALE: NTS		SHEET 44 OF 47	
DESIGN/CK BLS	FED. RD. DIV. NO. 6	STATE PROJECT NO. (SEE TITLE SHEET)	HIGHWAY NO. IH 20
CHECK BLS	STATE	DISTRICT DAL	COUNTY VARIOUS
CHECK MA	TEXAS	SECTION	JOB
CHECK BA	0095	14	269
		033, ETC	

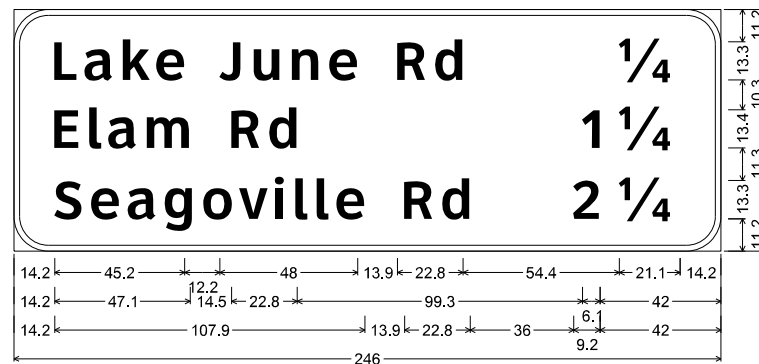

12.0" Radius, 2.0" Border, White on Green;
 "Lake June Rd", ClearviewHwy-5-W-R; "1/4", ClearviewHwy-5-W-R;
 "Elam Rd", ClearviewHwy-5-W-R; "1 1/4", ClearviewHwy-5-W-R;
 "Seagoville Rd", ClearviewHwy-5-W-R; "2 1/4", ClearviewHwy-5-W-R;

SHEET 117 SIGN 3

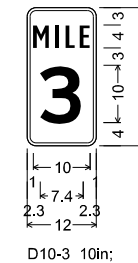

D10-3 10in;
 1.5" Radius, 0.5" Border, White on Green;
 "MILE", ClearviewHwy-2-W;
 "3", ClearviewHwy-6-W;

SHEET 117 SIGN 4
SHEET 117 SIGN 11

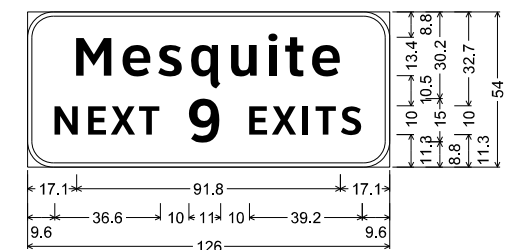

9.0" Radius, 1.5" Border, White on Green;
 "Mesquite", ClearviewHwy-5-W-R;
 "NEXT", ClearviewHwy-5-W-R;
 "9", ClearviewHwy-5-W-R;
 "EXITS", ClearviewHwy-5-W-R;

SHEET 117 SIGN 5

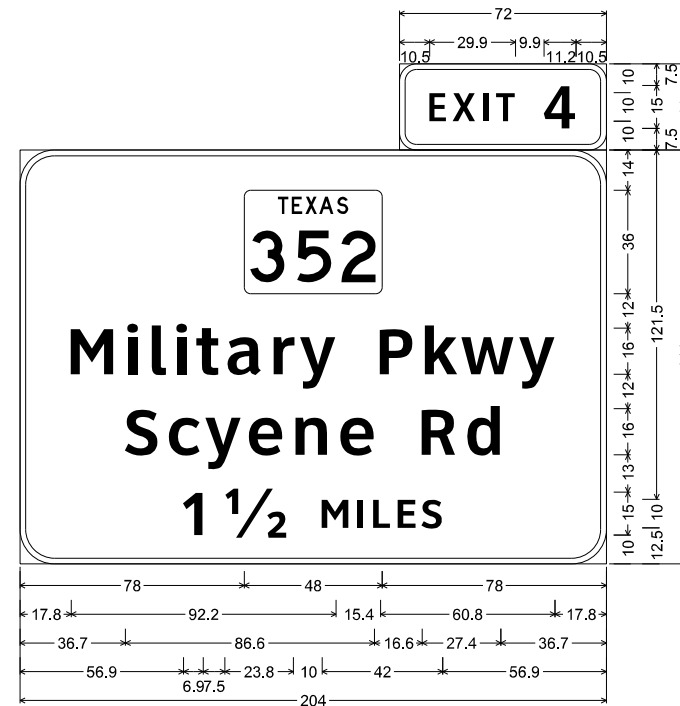

6.0" Radius, 2.0" Border, White on Green;
 "EXIT 4", ClearviewHwy-4-W;
 12.0" Radius, 2.0" Border, White on Green;
 State Highway 352 M1-6T3; "Military Pkwy", ClearviewHwy-5-W-R;
 "Scyene Rd", ClearviewHwy-5-W-R; "1 1/2", ClearviewHwy-5-W-R;
 "MILES", ClearviewHwy-5-W-R;

SHEET 117 SIGN 9



D3-1G(1) 8in;
 1.5" Radius, 0.5" Border, White on Green;
 "Bruton Rd", ClearviewHwy-3-W;

SHEET 118 SIGN 1
SHEET 118 SIGN 6



D1-2 8in LT-RT;
 1.9" Radius, 0.8" Border, White on Green;
 Standard Arrow Custom 12.0" X 7.1" 180"; "W Cartwright Rd", ClearviewHwy-3-W;
 1.9" Radius, 0.8" Border, White on Green;
 "Bruton Rd", ClearviewHwy-3-W; Standard Arrow Custom 12.0" X 7.1" 0°;

SHEET 118 SIGN 2

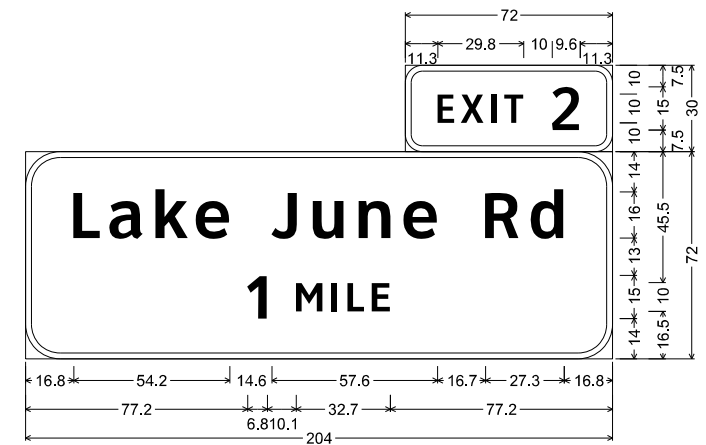

6.0" Radius, 2.0" Border, White on Green;
 "EXIT 2", ClearviewHwy-4-W;
 12.0" Radius, 2.0" Border, White on Green;
 "Lake June Rd", ClearviewHwy-5-W-R; "1 MILE", ClearviewHwy-5-W-R;

SHEET 118 SIGN 3

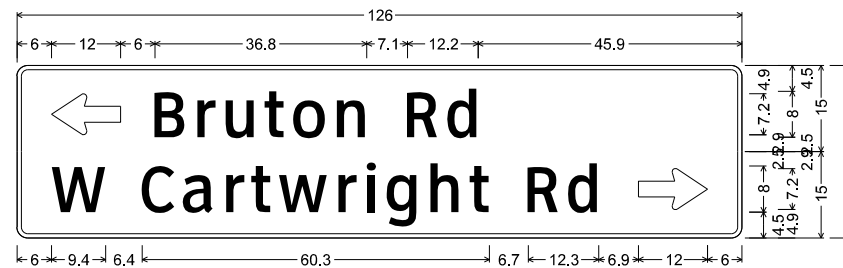

D1-2 8in LT-RT;
 1.9" Radius, 0.8" Border, White on Green;
 Standard Arrow Custom 12.0" X 7.1" 180"; "Bruton Rd", ClearviewHwy-3-W;
 1.9" Radius, 0.8" Border, White on Green;
 "W Cartwright Rd", ClearviewHwy-3-W; Standard Arrow Custom 12.0" X 7.1" 0°;

SHEET 118 SIGN 5



D3-1G(1) 8in;
 1.5" Radius, 0.5" Border, White on Green;
 "New Market Rd", ClearviewHwy-3-W;

SHEET 119 SIGN 1
SHEET 119 SIGN 2



Brenda L Sanchez, P.E. 03/20/23
 Signature of Registrant & Date

Texas Department of Transportation © 2023			
GUIDE SIGN DETAILS			
SCALE: NTS		SHEET 45 OF 47	
DESIGN/CK BLS	FED. RD. DIV. NO. 6	STATE PROJECT NO. (SEE TITLE SHEET)	HIGHWAY NO. IH 20
CHECK BLS	STATE	DISTRICT	COUNTY SHEET NO.
CHECK MA	TEXAS	DAL	VARIOUS
CHECK BA	CONTROL	SECTION	JOB
	0095	14	033, ETC
			270

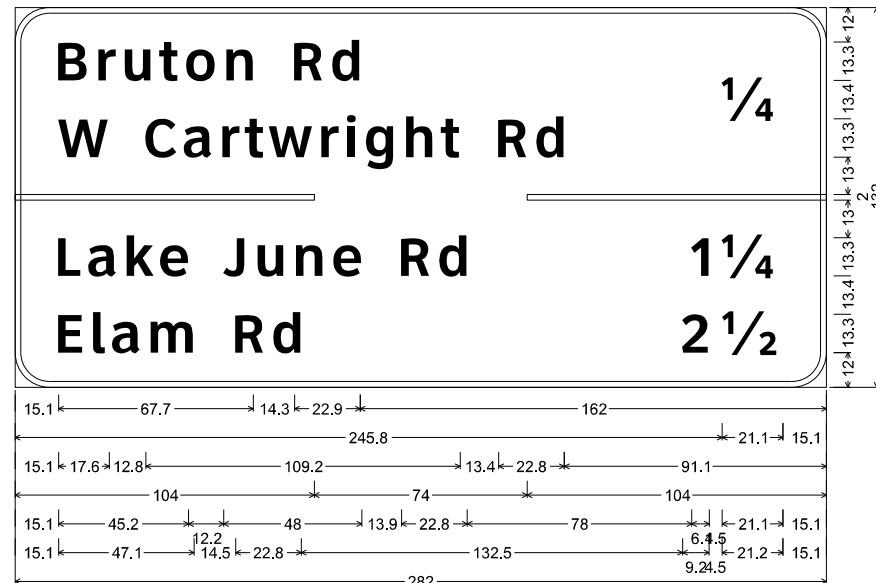

12.0" Radius, 2.0" Border, White on Green;
 "Bruton Rd", ClearviewHwy-5-W-R; "1/4", ClearviewHwy-5-W-R; "W Cartwright Rd", ClearviewHwy-5-W-R;
 "Lake June Rd", ClearviewHwy-5-W-R; "1 1/4", ClearviewHwy-5-W-R; "Elam Rd", ClearviewHwy-5-W-R;
 "2 1/2", ClearviewHwy-5-W-R;

SHEET 119 SIGN 2



D1-2 8in UP-UP;

1.9" Radius, 0.8" Border, White on Green;
 Standard Arrow Custom 10.0" X 7.1" 90°; "Mesquite Arena", ClearviewHwy-3-W;

1.9" Radius, 0.8" Border, White on Green;
 Standard Arrow Custom 10.0" X 7.1" 90°; "Convention Ctr", ClearviewHwy-3-W;

SHEET 120 SIGN 1

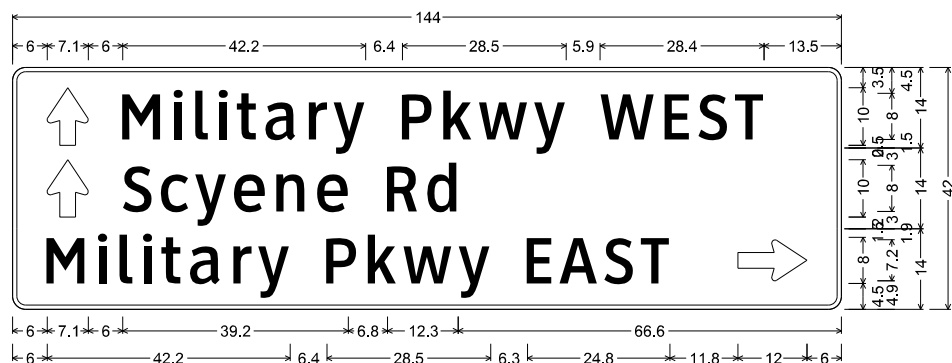

D1-3 8in UP-UP-RT;

2.3" Radius, 0.8" Border, White on Green;
 Standard Arrow Custom 10.0" X 7.1" 90°; "Military Pkwy WEST", ClearviewHwy-3-W;

2.3" Radius, 0.8" Border, White on Green;
 Standard Arrow Custom 10.0" X 7.1" 90°; "Scyene Rd", ClearviewHwy-3-W;

2.3" Radius, 0.8" Border, White on Green;
 "Military Pkwy EAST", ClearviewHwy-3-W; Standard Arrow Custom 12.0" X 7.1" 0°;

SHEET 120 SIGN 6

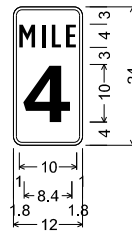

D10-3 10in;
 1.5" Radius, 0.5" Border, White on Green;
 "MILE", ClearviewHwy-2-W;
 "4", ClearviewHwy-6-W;

SHEET 119 SIGN 3
 SHEET 119 SIGN 6

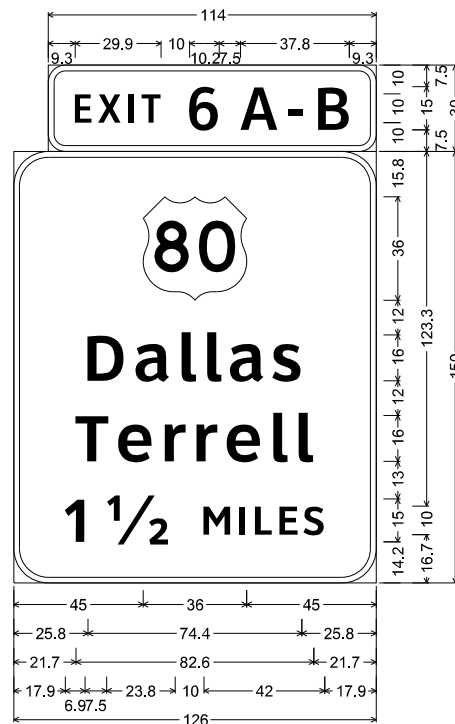

6.0" Radius, 2.0" Border, White on Green;
 "EXIT 6 A-B", ClearviewHwy-4-W;

12.0" Radius, 2.0" Border, White on Green;
 US 80 M1-4; "Dallas", ClearviewHwy-5-W-R;
 "Terrell", ClearviewHwy-5-W-R;
 "1 1/2", ClearviewHwy-5-W-R;
 "MILES", ClearviewHwy-5-W-R;

SHEET 120 SIGN 2

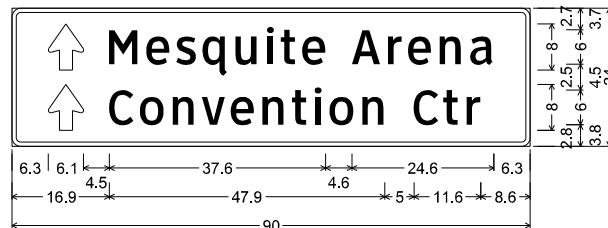

D7-1T;

1.5" Radius, 0.8" Border, White on Brown;
 Standard Arrow Custom 8.0" X 6.1" 90°;
 "Mesquite Arena", ClearviewHwy-3-W;
 Standard Arrow Custom 8.0" X 6.1" 90°;
 "Convention Ctr", ClearviewHwy-3-W;

SHEET 120 SIGN 7
 SHEET 121 SIGN 3

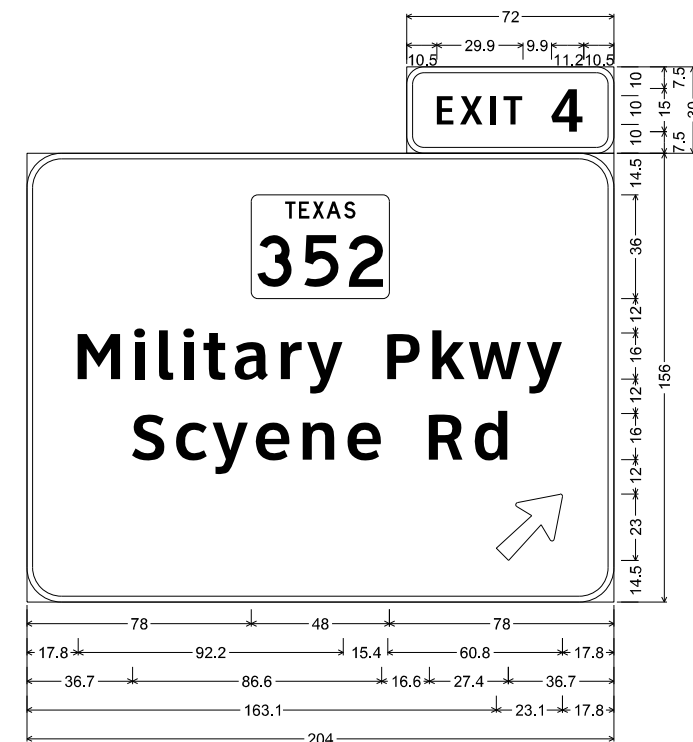

6.0" Radius, 2.0" Border, White on Green;
 "EXIT 4", ClearviewHwy-4-W;

12.0" Radius, 2.0" Border, White on Green;
 State Highway 352 M1-6T3; "Military Pkwy", ClearviewHwy-5-W-R;
 "Scyene Rd", ClearviewHwy-5-W-R; Arrow A-2 - 29.3" 45°;

SHEET 120 SIGN 4

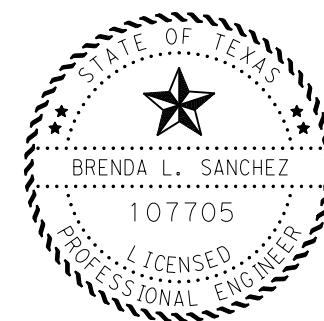

Brenda L Sanchez, P.E. 03/20/23
 Signature of Registrant & Date

Texas Department of Transportation				
© 2023				
GUIDE SIGN DETAILS				
SCALE: NTS		SHEET 46 OF 47		
DESIGN/CK	FED. RD. DIV. NO.	STATE PROJECT NO.		HIGHWAY NO.
BLS	6	(SEE TITLE SHEET)		IH 20
BLS	STATE	DISTRICT	COUNTY	SHEET NO.
CHECK MA	TEXAS	DAL	VARIOUS	271
CHECK BA	CONTROL	SECTION	JOB	
	0095	14	033, ETC	

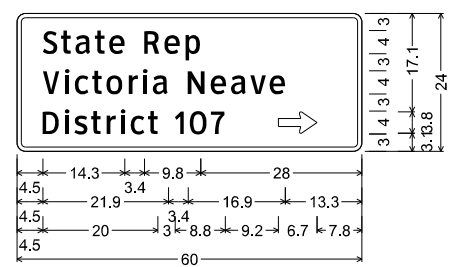

D23-1TR(3)_VARx24;
1.5" Radius, 0.8" Border, White on Green;
"State Rep", ClearviewHwy-3-W;
"Victoria Neave", ClearviewHwy-3-W;
"District 107", ClearviewHwy-3-W;
Standard Arrow Custom 6.8" X 3.7" 0";

SHEET 120 SIGN 8

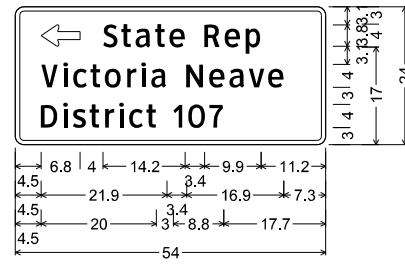

D23-1TL(3)_VARx24;
1.5" Radius, 0.8" Border, White on Green;
Standard Arrow Custom 6.8" X 3.7" 180°;
"State Rep", ClearviewHwy-3-W;
"Victoria Neave", ClearviewHwy-3-W;
"District 107", ClearviewHwy-3-W;

SHEET 121 SIGN 1

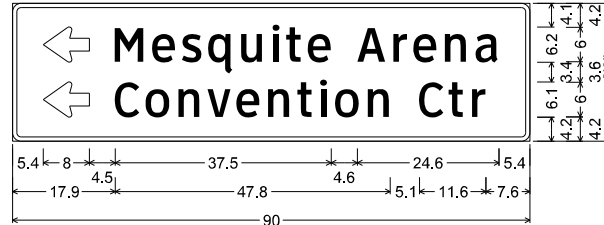

D7-1T;
1.5" Radius, 0.8" Border, White on Brown;
Standard Arrow Custom 8.0" X 6.1" 180°;
"Mesquite Arena", ClearviewHwy-3-W;
Standard Arrow Custom 8.0" X 6.1" 180°;
"Convention Ctr", ClearviewHwy-3-W;

SHEET 121 SIGN 2
SHEET 121 SIGN 10

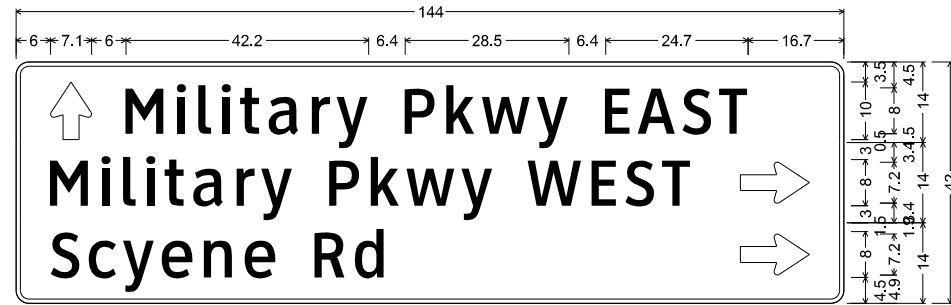

D1-3 8in UP-RT-RT;
2.3" Radius, 0.8" Border, White on Green;
Standard Arrow Custom 10.0" X 7.1" 90°; "Military Pkwy EAST", ClearviewHwy-3-W;
2.3" Radius, 0.8" Border, White on Green;
"Military Pkwy WEST", ClearviewHwy-3-W; Standard Arrow Custom 12.0" X 7.1" 0°;
2.3" Radius, 0.8" Border, White on Green;
"Scyene Rd", ClearviewHwy-3-W; Standard Arrow Custom 12.0" X 7.1" 0°;

SHEET 121 SIGN 4

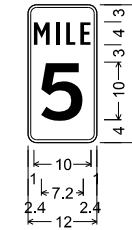

D10-3 10in;
1.5" Radius, 0.5" Border, White on Green;
"MILE", ClearviewHwy-2-W;
"5", ClearviewHwy-6-W;

SHEET 121 SIGN 8
SHEET 121 SIGN 12

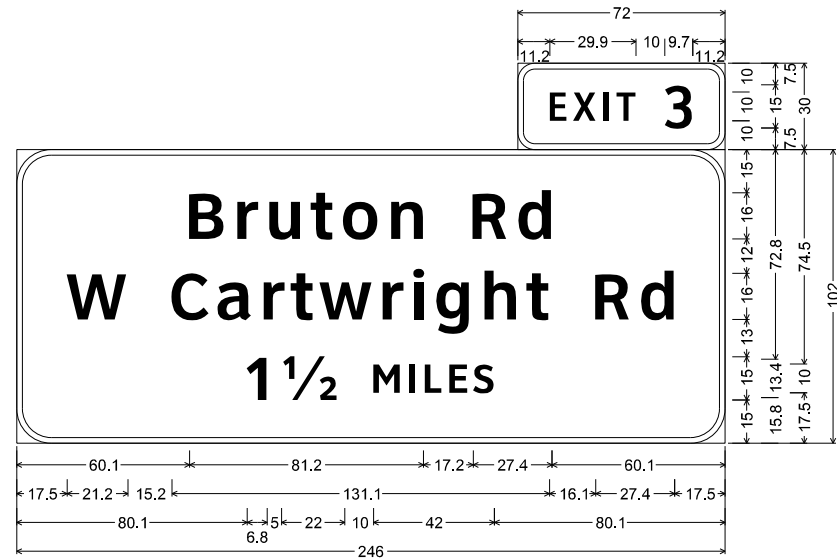

E1-5P_72x30;
6.0" Radius, 2.0" Border, White on Green;
"EXIT 3", ClearviewHwy-4-W;

E1-1a_VARx150;
12.0" Radius, 2.0" Border, White on Green;
"Bruton Rd", ClearviewHwy-5-W-R; "W Cartwright Rd", ClearviewHwy-5-W-R;
"1", ClearviewHwy-5-W-R; "1/2", ClearviewHwy-5-W; "MILES", ClearviewHwy-5-W-R;

SHEET 121 SIGN 6



E1-5P_72x30;
6.0" Radius, 2.0" Border, White on Green;
"EXIT 4", ClearviewHwy-4-W;
E1-1a_VARx150;
12.0" Radius, 2.0" Border, White on Green;
State Highway 352 M1-6T3; "Scyene Rd", ClearviewHwy-5-W-R;
"Military Pkwy", ClearviewHwy-5-W-R; Arrow A-3 - 35.6" 45°;

SHEET 121 SIGN 7

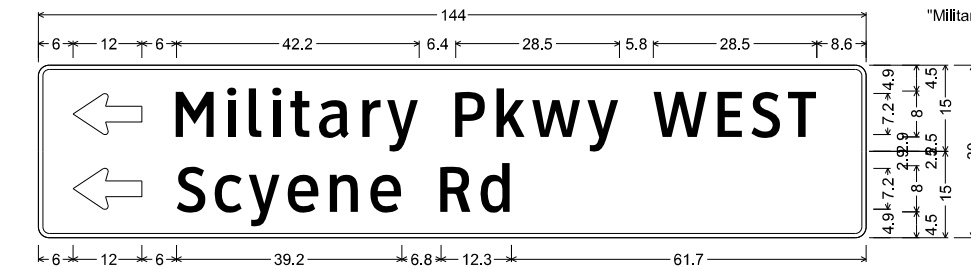

D1-2 8in LT-LT;
1.9" Radius, 0.8" Border, White on Green;
Standard Arrow Custom 12.0" X 7.1" 180°; "Military Pkwy WEST", ClearviewHwy-3-W;
1.9" Radius, 0.8" Border, White on Green;
Standard Arrow Custom 12.0" X 7.1" 180°; "Scyene Rd", ClearviewHwy-3-W;

SHEET 121 SIGN 9

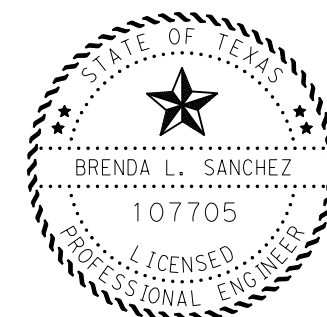

Brenda L Sanchez, P.E. 03/20/23
Signature of Registrant & Date



GUIDE SIGN DETAILS

SCALE: NTS SHEET 47 OF 47

DESIGN/CK	FED. RD. DIV. NO.	STATE PROJECT NO.		HIGHWAY NO.
BLS	6	(SEE TITLE SHEET)		IH 20
CHECK	STATE	DISTRICT	COUNTY	SHEET NO.
BLS	TEXAS	DAL	VARIOUS	272
CHECK	CONTROL	SECTION	JOB	
MA	0095	14	033, ETC	
CHECK	BA			

GENERAL NOTES:

THE DIMENSIONS SHOWN ON THESE OVERHEAD SIGN STRUCTURE ELEVATIONS ARE FURNISHED TO THE CONTRACTOR FOR BIDDING PURPOSES ONLY

DESIGNS SHOWN FOR OVERHEAD SIGN STRUCTURES WERE DEVELOPED FROM DESIGN CROSS SECTIONS AND DESIGN TYPICAL SECTIONS.

IT IS THE RESPONSIBILITY OF THE CONTRACTOR TO TAKE ACTUAL MEASUREMENTS BEFORE ORDERING FABRICATION OF THE COMPONENT PARTS OF THE OVERHEAD SIGN STRUCTURES

TRUSS ELEVATION 127.00

DESIGN DATA

SPAN LENGTH	35.00	FT
DESIGN HEIGHT	BELOW 30	FT
TOWER HEIGHT	28.40	FT
DESIGN SIGN AREA	350.00	SF
ACTUAL SIGN AREA	137.00	SF
PENETROMETER VALUE	ASSUME 15	
DESIGN LOADS	TORSION 161.98	K-FT
	MOMENT 300.02	K-FT

COSS-Z4 & Z4I-10

STRUCTURE DATA

STRUCTURE CODE	COSS-Z4 & Z4I-10
TRUSS SIZE	4.0' X 4.0'
TOWER SIZE	24" O.D. PIPE

SUMMARY OF DRILLED SHAFT

16	LF OF 48" DIA. DRILLED SHAFT
BOTTOM BASE PLATE ELEV.	98.60
TOP DRILLED SHAFT ELEV.	98.35
GROUND ELEV.	97.85
BOTTOM DRILLED SHAFT ELEV.	82.35

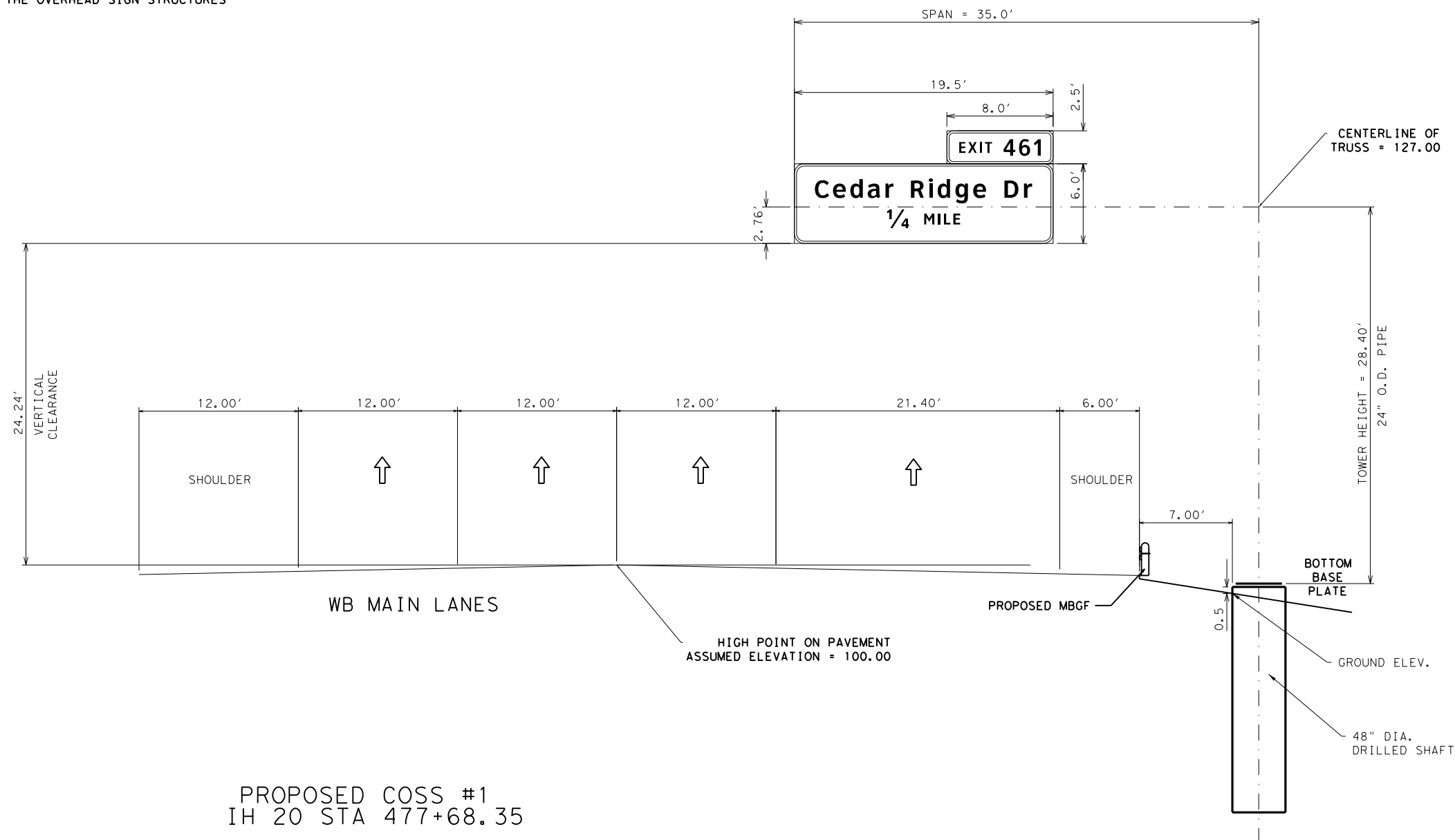

PROPOSED COSS #1
IH 20 STA 477+68.35

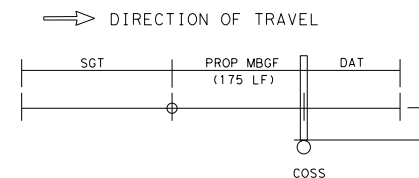

MBGF
PLACEMENT
MOW STRIP = 13.71 CY
DELINEATORS = 3 EA

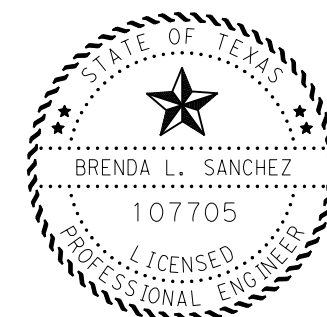

Brenda L Sanchez, P.E. 03/20/23
Signature of Registrant & Date



OVERHEAD SIGN
STRUCTURE DETAILS

SCALE: NTS SHEET 1 OF 1

DESIGN/CK	FED. RD. DIV. NO.	STATE PROJECT NO.		HIGHWAY NO.
CHECK	6	(SEE TITLE SHEET)		IH0020
BS	STATE	DISTRICT	COUNTY	SHEET NO.
CHECK	TEXAS	DALLAS	VARIOUS	273
CHECK	CONTROL	SECTION	JOB	
	0095	14	033, ETC	

REQUIREMENTS FOR OVERHEAD AND LARGE GROUND-MOUNTED SIGNS

TYPICAL EXAMPLES

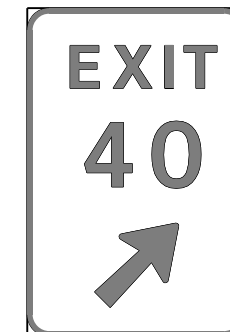
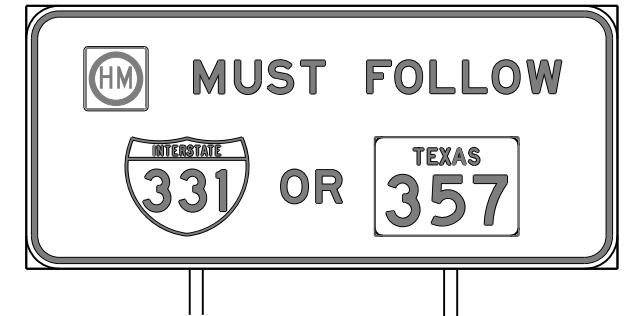
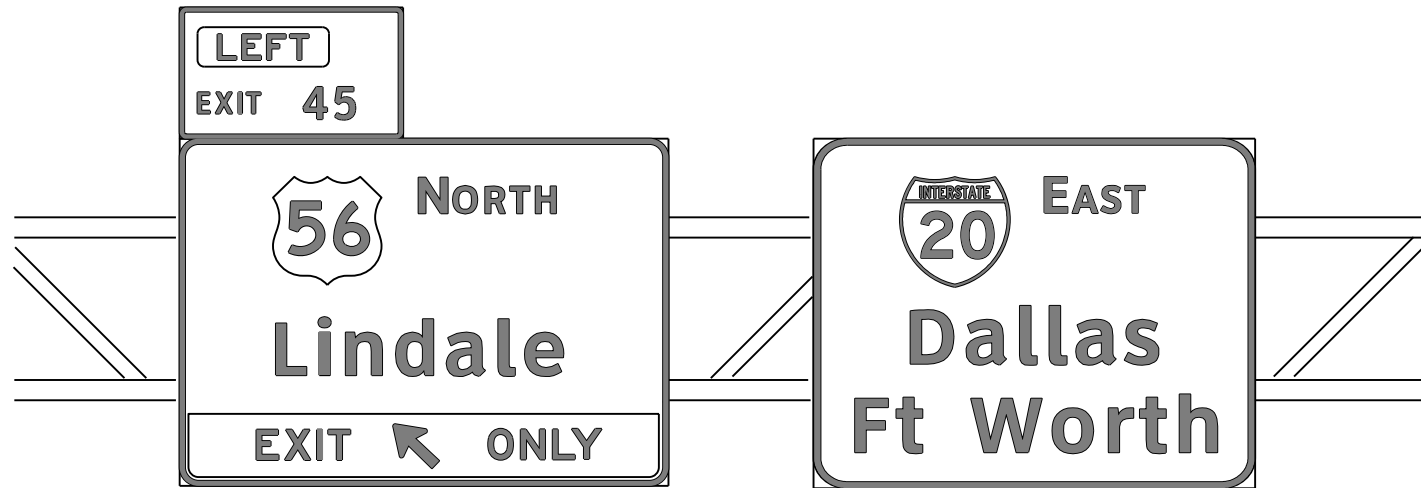

GENERAL NOTES

- Signs to be furnished shall be as detailed elsewhere in the plans and/or as shown on sign summary sheet. Standard sign designs and arrow dimensions can be found in the "Standard Highway Sign Designs for Texas" (SHSD).
- Black legend shall use the Federal Highway Administration (FHWA) Standard Highway Alphabets (B, C, D, E, Emod, or F). White legend shall use the Clearview Alphabet. The following Clearview fonts shall be used to replace the existing white FHWA lettering, when not specified in the SHSD or in the plans.

B	CV-1W
C	CV-2W
D	CV-3W
E	CV-4W
Emod	CV-5WR
F	CV-6W

- Lateral spacing between letters and numerals shall conform with the SHSD, and any approved changes thereto. Lateral spacing of legend shall provide a balanced appearance when spacing is not shown.
- Black legend shall be applied by screening process or cut-out acrylic non-reflective black film to background sheeting, or combination thereof.
- White legend and borders shall be cut-out white sheeting applied to colored background sheeting.
- Information regarding borders and radii for signs is found in the "Standard Highway Sign Designs for Texas". Dimensions shown and described for borders and corner radii on parent sign are nominal. Borders may vary in width as much as 1/2 inch. Corner radii above 3 inches may vary in width as much as 1 inch. Borders and corner radii within a parent sign must be of matching widths. The sign area outside the corner radius need not be trimmed or rounded if fabricated from an extruded material.
- Sign substrate for ground-mounted signs shall be any material that meets the Departmental Material Specification requirements of DMS-7110 or approved alternative. Sign substrate for overhead signs shall be any material that meets DMS-7110. Exit Number Panels attached above the parent sign shall be made with the same substrate and sheeting as the parent sign.
- Mounting details of attachments to parent sign face are shown on Standard Plan Sheet TSR(5). Mounting details of exit number panels above parent sign are shown in the "SMD series" Standard Plan Sheets.
- Background sheeting shall be applied to the substrate per sheeting manufacturer's recommendations. Sheeting will not be allowed to bridge the horizontal gap between panels.
- Cut all legend, symbols, borders, and direct applied sign attachments at panel joints.

DEPARTMENTAL MATERIAL SPECIFICATIONS

ALUMINUM SIGN BLANKS	DMS-7110
SIGN FACE MATERIALS	DMS-8300

The Standard Highway Sign Designs for Texas (SHSD) can be found at the following website.

<http://www.txdot.gov/>

SHEETING REQUIREMENTS

USAGE	COLOR	SIGN FACE MATERIAL
BACKGROUND	WHITE	TYPE B OR C SHEETING
BACKGROUND	ALL OTHERS	TYPE B OR C SHEETING
LEGEND & BORDERS	WHITE	TYPE D SHEETING
LEGEND & BORDERS	BLACK	ACRYLIC NON-REFLECTIVE FILM

DISCLAIMER: The use of this standard is governed by the "Texas Engineering Practice Act". No warranty of any kind is made by TxDOT for any purpose whatsoever. TxDOT assumes no responsibility for the conversion of any other formats or for incorrect results or damages resulting from its use.

DATE: 3/1/2023 4:32:04 PM
 FILE: T:\DAL\TRAFFIC\2023 PS&E\I.H. 20\Plan_Sets\Standards\non-pdf_standards.dwg

Texas Department of Transportation				Traffic Operations Division Standard	
<h2 style="margin: 0;">TYPICAL SIGN REQUIREMENTS</h2> <h3 style="margin: 0;">TSR(1) - 13</h3>					
FILE:	fstr1-13.dgn	DN:	TxDOT	CK:	TxDOT
©TxDOT	October 2003	CONT	SECT	JOB	HIGHWAY
REVISIONS		0095	14	033, ETC	IH 20, ETC
12-03	7-13	DIST	COUNTY	SHEET NO.	
9-08		DAL	KAUFMAN, ETC	274	

REQUIREMENTS FOR ATTACHMENTS TO OVERHEAD AND LARGE GROUND MOUNTED SIGNS

DATE: 3/1/2023 4:32:04 PM
 FILE: T:\DAL\TRAFM\FY 2023 PS&E\I.H. 20\Plan Set\Standards\non-paf_standards.dwg
 The use of this standard is governed by the "Texas Engineering Practice Act". No warranty of any kind is made by TxDOT for any purpose whatsoever. TxDOT assumes no responsibility for the conversion of any other formats or for incorrect results or damages resulting from its use.

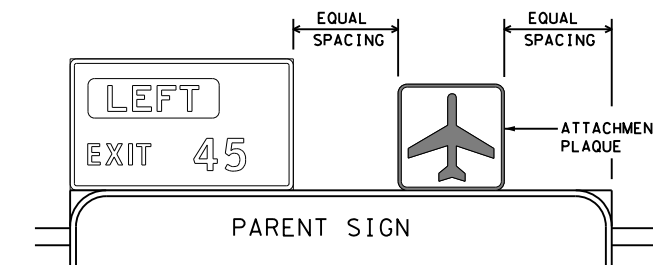
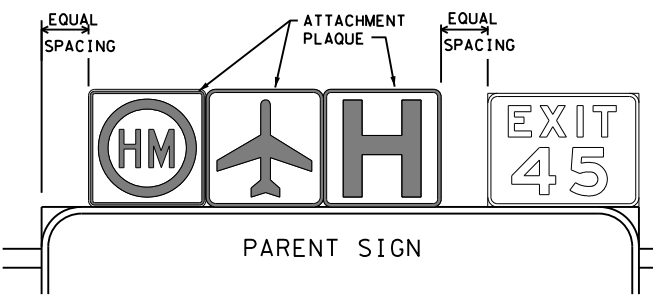
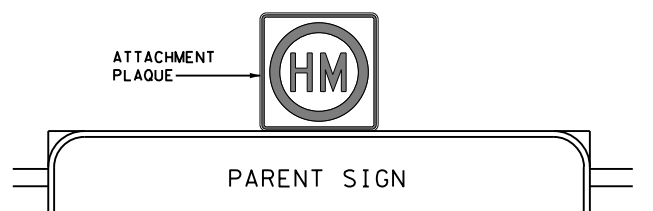
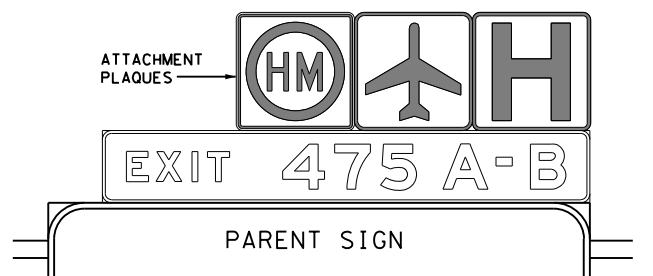
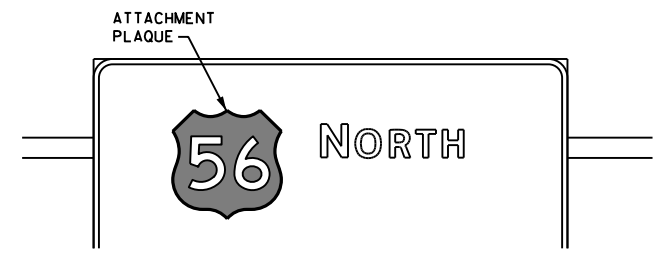

TYPICAL EXAMPLES

DEPARTMENTAL MATERIAL SPECIFICATIONS	
ALUMINUM SIGN BLANKS	DMS-7110
SIGN FACE MATERIALS	DMS-8300

SHEETING REQUIREMENTS		
USAGE	COLOR	SIGN FACE MATERIAL
BACKGROUND	ALL	TYPE B OR C SHEETING
LEGEND & BORDERS	BLACK	ACRYLIC NON-REFLECTIVE FILM
LEGEND & BORDERS	ALL OTHERS	TYPE B OR C SHEETING

GENERAL NOTES

- Signs to be furnished shall be as detailed elsewhere in the plans and/or as shown on sign tabulation sheet. Standard sign designs and arrow dimensions can be found in the "Standard Highway Sign Designs for Texas" (SHSD).
- Route Marker legends (ie. IH, US, SH and FM shields) shall use the Federal Highway Administration (FHWA) Standard Highway Alphabets (B, C, D, E, Emod, or F).
- Lateral spacing between letters and numerals shall conform with the SHSD, and any approved changes thereto. Lateral spacing of legend shall provide a balanced appearance when spacing is not shown.
- Black legend and borders shall be applied by screening process or cut-out acrylic non-reflective black film to background sheeting, or combination thereof.
- White legend and borders shall be applied by screening process with transparent colored ink, transparent colored overlay film to white background sheeting or cut-out white sheeting to colored background sheeting, or combination thereof.
- Colored legend and borders shall be applied by screening process with transparent colored ink, transparent colored overlay film or colored sheeting to white background sheeting, or combination thereof.
- Route markers and other attachments within the parent sign face shall be direct applied unless otherwise specified in the plans. Attachments not direct applied shall use 0.063 inch thick one piece sheet aluminum signs (Type A).
- General Service Plaques shall be 0.080 inch thick and Routing Plaques shall be 0.100 inch thick.
- The priority for Routing Plaques shall be (left to right) Hazardous Material, Airport then Hospital. See examples for mounting location.
- Mounting details of attachments to parent signs face are shown on Standard Plan Sheet TSR(5). Mounting details of sign plaque attachments above and below parent sign are shown in the "SMD series" Standard Plan Sheets.
- Plaques shall be horizontally centered at the top of the parent sign. If an exit number panel exists, the plaque shall be centered between the edge of the parent sign and the edge of the exit number panel. The plaque may be placed above the exit number panel when there is insufficient space.

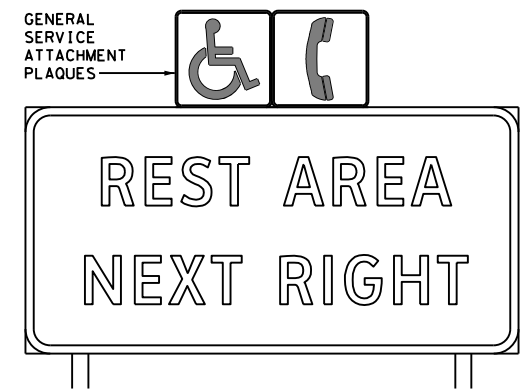

REQUIREMENTS FOR EXIT ONLY AND LEFT EXIT PANELS

DEPARTMENTAL MATERIAL SPECIFICATIONS	
ALUMINUM SIGN BLANKS	DMS-7110
SIGN FACE MATERIALS	DMS-8300

SHEETING REQUIREMENTS FOR OVERHEAD EXIT PANELS		
USAGE	COLOR	SIGN FACE MATERIAL
BACKGROUND	FLUORESCENT YELLOW	TYPE B _{FL} OR C _{FL} SHEETING
LEGEND	BLACK	ACRYLIC NON-REFLECTIVE FILM

GENERAL NOTES

- Signs to be furnished shall be as detailed elsewhere in the plans and/or as shown on sign tabulation sheet. Standard sign designs and arrow dimensions can be found in the "Standard Highway Sign Designs for Texas" (SHSD). Individual panel sizes shown in the plans may be adjusted to fit actual parent sign sizes if necessary.
- Exit Panel legend shall use the Federal Highway Administration (FHWA) Standard Highway Alphabets E Series.
- Lateral spacing between letters and numerals shall conform with the SHSD, and any approved changes thereto. Lateral spacing of legend shall provide a balanced appearance when spacing is not shown.
- Black legend shall be applied by screening process or cut-out acrylic non-reflective black film to yellow background sheeting, or combination thereof.
- Exit Only and Left Exit panels within the parent sign face shall be direct applied unless otherwise specified in the plans. Panels not direct applied shall use 0.063 inch thick one piece sheet aluminum signs (Type A).
- Mounting details of Exit Only and Left Exit panel attachments to parent signs face are shown on Standard Plan Sheet TSR(5).

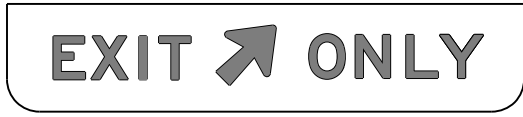
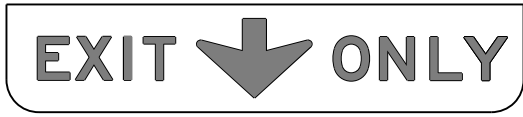

TYPICAL EXAMPLES

The Standard Highway Sign Designs for Texas (SHSD) can be found at the following website.
<http://www.txdot.gov/>

Texas Department of Transportation		Traffic Operations Division Standard	
<h2>TYPICAL SIGN REQUIREMENTS</h2>			
<h3>TSR(2) - 13</h3>			
FILE: tsr2-13.dgn	DN: TxDOT	CK: TxDOT	DW: TxDOT
©TxDOT October 2003	CONT	SECT	JOB
REVISIONS	0095 14	033, ETC	IH 20, ETC
12-03 7-13	DIST	COUNTY	SHEET NO.
9-08	DAL	KAUFMAN, ETC	275

DISCLAIMER: The use of this standard is governed by the "Texas Engineering Practice Act". No warranty of any kind is made by TxDOT for any purpose whatsoever. TxDOT assumes no responsibility for the conversion of this standard to any other format or for incorrect results or damages resulting from its use.

DATE: 3/1/2023 4:32:02 PM
 FILE: T:\DAL\TRAFM\FY_2023_PS&E\I.H. 20\Plan_Set\Standards\non-paf_standards\2024\I.H. Standards.dwg

REQUIREMENTS FOR INDEPENDENT MOUNTED ROUTE SIGNS

SHEETING REQUIREMENTS		
USAGE	COLOR	SIGN FACE MATERIAL
BACKGROUND	WHITE	TYPE A SHEETING
BACKGROUND	ALL OTHERS	TYPE B OR C SHEETING
LEGEND & BORDERS	WHITE	TYPE A SHEETING
LEGEND & BORDERS	BLACK	ACRYLIC NON-REFLECTIVE FILM
LEGEND & BORDERS	ALL OTHERS	TYPE B or C SHEETING

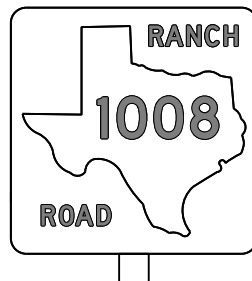
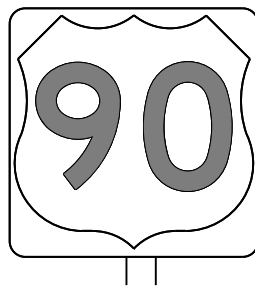
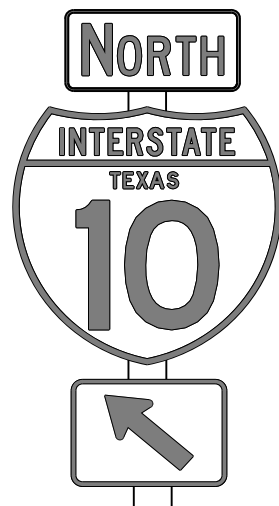

TYPICAL EXAMPLES

REQUIREMENTS FOR BLUE, BROWN & GREEN D AND I SERIES GUIDE SIGNS

SHEETING REQUIREMENTS		
USAGE	COLOR	SIGN FACE MATERIAL
BACKGROUND	ALL	TYPE B OR C SHEETING
LEGEND & BORDERS	WHITE	TYPE D SHEETING
LEGEND, SYMBOLS & BORDERS	ALL OTHERS	TYPE B OR C SHEETING

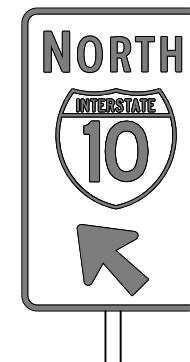
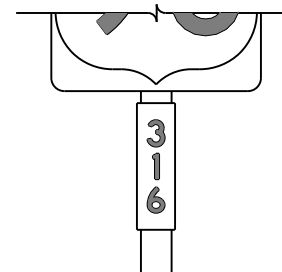

TYPICAL EXAMPLES

GENERAL NOTES

- Signs to be furnished shall be as detailed elsewhere in the plans and/or as shown on sign tabulation sheet. Standard sign designs and arrow dimensions can be found in the "Standard Highway Sign Designs for Texas" (SHSD).
- White legend shall use the Clearview Alphabet. The following Clearview fonts shall be used to replace the existing white Federal Highway Administration (FHWA) Standard Highway Alphabets, when not specified in the SHSD, or in the plans.

B	CV-1W
C	CV-2W
D	CV-3W
E	CV-4W
Emod	CV-5WR
F	CV-6W
- Route sign legend (ie. IH, US, SH and FM shields) shall use the Federal Highway Administration (FHWA) Standard Highway Alphabets B, C, D, E, Emod or F).
- Lateral spacing between letters and numerals shall conform with the SHSD, and any approved changes thereto. Lateral spacing of legend shall provide a balanced appearance when spacing is not shown.
- Independent mounted route sign with white or colored legend and borders shall be applied by screening process with transparent color ink, transparent colored overlay film to white background sheeting or cut-out white sheeting to colored background sheeting, or combination thereof. White legend, symbols and borders on all other signs shall be cut-out white sheeting applied to colored background sheeting.
- Information regarding borders and radii for signs is found in the "Standard Highway Sign Designs for Texas". Dimensions shown and described for borders and corner radii on parent sign are nominal. Borders may vary in width as much as 1/2 inch. Corner radii above 3 inches may vary in width as much as 1 inch. Borders and corner radii within a parent sign must be of matching widths. The sign area outside the corner radius should be trimmed or rounded.
- Sign substrate shall be any material that meets the Departmental Material Specification requirements of DMS-7110 or approved alternative.
- Mounting details of roadside signs are shown in the "SMD series" Standard Plan Sheets.

DEPARTMENTAL MATERIAL SPECIFICATIONS	
ALUMINUM SIGN BLANKS	DMS-7110
SIGN FACE MATERIALS	DMS-8300

ALUMINUM SIGN BLANKS THICKNESS	
Square Feet	Minimum Thickness
Less than 7.5	0.080
7.5 to 15	0.100
Greater than 15	0.125

The Standard Highway Sign Designs for Texas (SHSD) can be found at the following website:
<http://www.txdot.gov/>

		Traffic Operations Division Standard	
<h3>TYPICAL SIGN REQUIREMENTS</h3>			
<h3>TSR(3) - 13</h3>			
FILE:	tsr3-13.dgn	DN:	TxDOT
© TxDOT	October 2003	CK:	TxDOT
REVISIONS	0095 14	DW:	TxDOT
12-03 7-13		JOB	HIGHWAY
9-08		033, ETC	IH 20, ETC
		DIST	COUNTY
		DAL	KAUFMAN, ETC
		SHEET NO.	276

DATE: 3/11/2023 4:32:02 PM
 FILE: T:\DAL\TRAFFIC\2023 PS&E\1H_20\Plan_Set\Standards\non-paf_standards\signs\standards\signs.dwg
 The use of this standard is governed by the "Texas Engineering Practice Act". No warranty of any kind is made by TxDOT for any purpose whatsoever. TxDOT assumes no responsibility for the conversion of any kind to other formats or for incorrect results or damages resulting from its use.

REQUIREMENTS FOR RED BACKGROUND REGULATORY SIGNS

(STOP, YIELD, DO NOT ENTER AND WRONG WAY SIGNS)

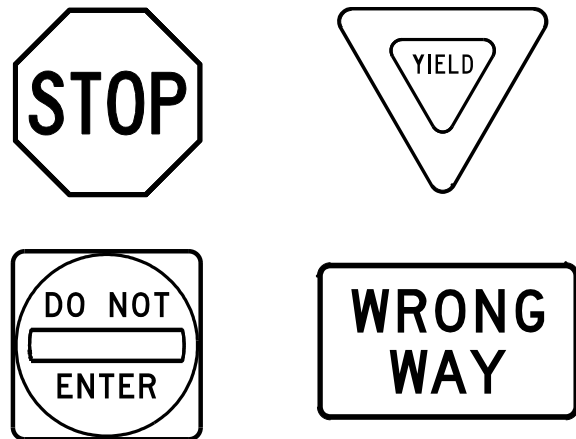

REQUIREMENTS FOR FOUR SPECIFIC SIGNS ONLY

SHEETING REQUIREMENTS		
USAGE	COLOR	SIGN FACE MATERIAL
BACKGROUND	RED	TYPE B OR C SHEETING
BACKGROUND	WHITE	TYPE B OR C SHEETING
LEGEND & BORDERS	WHITE	TYPE B OR C SHEETING
LEGEND	RED	TYPE B OR C SHEETING

REQUIREMENTS FOR WHITE BACKGROUND REGULATORY SIGNS

(EXCLUDING STOP, YIELD, DO NOT ENTER AND WRONG WAY SIGNS)



TYPICAL EXAMPLES

SHEETING REQUIREMENTS		
USAGE	COLOR	SIGN FACE MATERIAL
BACKGROUND	WHITE	TYPE A SHEETING
BACKGROUND	ALL OTHERS	TYPE B OR C SHEETING
LEGEND, BORDERS AND SYMBOLS	BLACK	ACRYLIC NON-REFLECTIVE FILM
LEGEND, BORDERS AND SYMBOLS	ALL OTHER	TYPE B OR C SHEETING

REQUIREMENTS FOR WARNING SIGNS

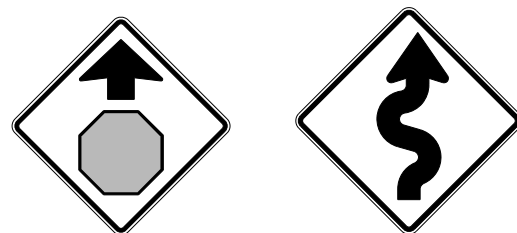

TYPICAL EXAMPLES

SHEETING REQUIREMENTS		
USAGE	COLOR	SIGN FACE MATERIAL
BACKGROUND	FLOURESCENT YELLOW	TYPE B _{FL} OR C _{FL} SHEETING
LEGEND & BORDERS	BLACK	ACRYLIC NON-REFLECTIVE FILM
LEGEND & SYMBOLS	ALL OTHER	TYPE B OR C SHEETING

REQUIREMENTS FOR SCHOOL SIGNS



TYPICAL EXAMPLES

SHEETING REQUIREMENTS		
USAGE	COLOR	SIGN FACE MATERIAL
BACKGROUND	WHITE	TYPE A SHEETING
BACKGROUND	FLOURESCENT YELLOW GREEN	TYPE B _{FL} OR C _{FL} SHEETING
LEGEND, BORDERS AND SYMBOLS	BLACK	ACRYLIC NON-REFLECTIVE FILM
SYMBOLS	RED	TYPE B OR C SHEETING

GENERAL NOTES

- Signs to be furnished shall be as detailed elsewhere in the plans and/or as shown on sign tabulation sheet. Standard sign designs and arrow dimensions can be found in the "Standard Highway Sign Designs for Texas" (SHSD).
- Sign legend shall use the Federal Highway Administration (FHWA) Standard Highway Alphabets (B, C, D, E, Emod or F).
- Lateral spacing between letters and numerals shall conform with the SHSD, and any approved changes thereto. Lateral spacing of legend shall provide a balanced appearance when spacing is not shown.
- Black legend and borders shall be applied by screening process or cut-out acrylic non-reflective black film to background sheeting, or combination thereof.
- White legend and borders shall be applied by screening process with transparent colored ink, transparent colored overlay film to white background sheeting or cut-out white sheeting to colored background sheeting, or combination thereof.
- Colored legend shall be applied by screening process with transparent colored ink, transparent colored overlay film or colored sheeting to background sheeting, or combination thereof.
- Sign substrate shall be any material that meets the Departmental Material Specification requirements of DMS-7110 or approved alternative.
- Mounting details for roadside mounted signs are shown in the "SMD series" Standard Plan Sheets.

ALUMINUM SIGN BLANKS THICKNESS	
Square Feet	Minimum Thickness
Less than 7.5	0.080
7.5 to 15	0.100
Greater than 15	0.125

DEPARTMENTAL MATERIAL SPECIFICATIONS	
ALUMINUM SIGN BLANKS	DMS-7110
SIGN FACE MATERIALS	DMS-8300

The Standard Highway Sign Designs for Texas (SHSD) can be found at the following website:
<http://www.txdot.gov/>

		<i>Traffic Operations Division Standard</i>	
<h2>TYPICAL SIGN REQUIREMENTS</h2>			
<h3>TSR(4) - 13</h3>			
FILE:	tsr4-13.dgn	DN:	TxDOT
© TxDOT	October 2003	CK:	TxDOT
REVISIONS		DW:	TxDOT
0095	14	CONT	SECT
12-03	7-13	JOB	HIGHWAY
9-08		033, ETC	IH 20, ETC
DIST	COUNTY	SHEET NO.	
DAL	KAUFMAN, ETC	277	

DISCLAIMER: The use of this standard is governed by the "Texas Engineering Practice Act". No warranty of any kind is made by TxDOT for any purpose whatsoever. TxDOT assumes no responsibility for the conversion of this standard to other formats or for incorrect results or damages resulting from its use.

DATE: 3/1/2023 4:32:03 PM
 FILE: T:\DAL\TRAFFIC\2023_PS&E\I\H_20\Plan_Set\Standards\non-paf_standards\2016\184-391-arrows.dwg

ARROW DETAILS

for Large Ground-Mounted and Overhead Guide Signs

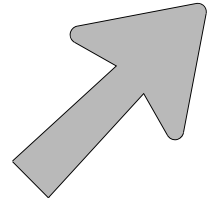

Type A

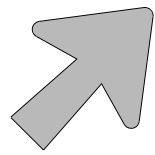

Type B

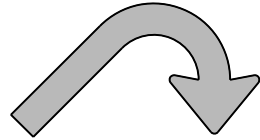

E-3

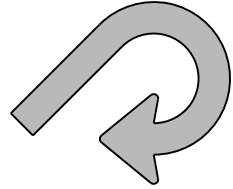

E-4

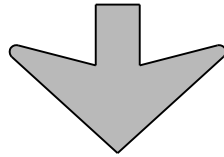

Down Arrow

TYPE	LETTER SIZE	USE
A-1	10.67" U/L and 10" Caps	Single Lane Exits
A-2	13.33" U/L and 12" Caps	
A-3	16" & 20" U/L	
B-1	10.67" U/L and 10" Caps	Multiple Lane Exits
B-2	13.33" U/L and 12" Caps	
B-3	16" & 20" U/L	

CODE	USED ON SIGN NO.
E-3	E5-1aT
E-4	E5-1bT

NOTE

Arrow dimensions are shown in the "Standard Highway Sign Designs for Texas" manual.

The Standard Highway Sign Designs for Texas (SHSD) can be found at the following website:

<http://www.txdot.gov/>

SIGN BLANK PUNCHING DETAILS FOR ATTACHMENTS WHEN SPECIFIED TO BE TYPE A ALUMINUM SIGNS (FOR MOUNTING TO GUIDE SIGN FACE)

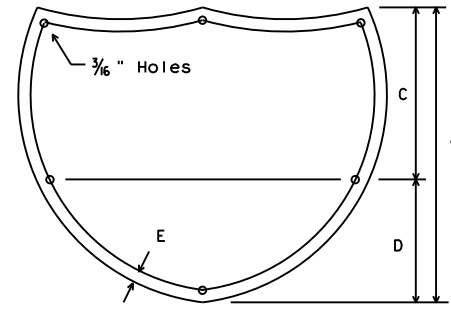

INTERSTATE ROUTE MARKERS

A	C	D	E
36	21	15	1 1/2
48	28	20	1 3/4

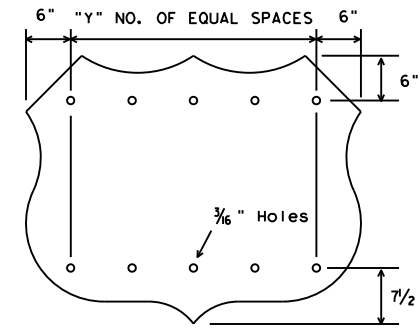

U.S. ROUTE MARKERS

Sign Size	"Y"
24x24	2
30x24	3
36x36	3
45x36	4
48x48	4
60x48	5

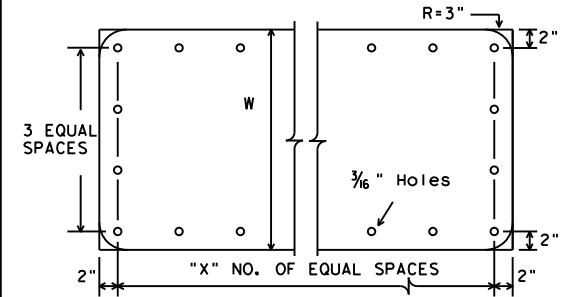

STATE ROUTE MARKERS

No. of Digits	W	X
4	24	4
4	36	5
4	48	6
3	24	3
3	36	4
3	48	5

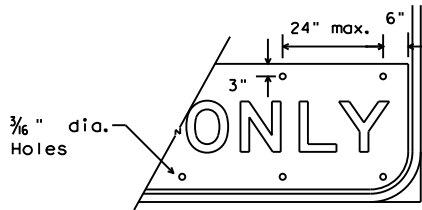

EXIT ONLY PANEL

MOUNTING DETAILS OF ATTACHMENTS TO GUIDE SIGN FACE ("EXIT ONLY" AND "LEFT EXIT" PANELS, ROUTE MARKERS AND OTHER ATTACHMENTS)

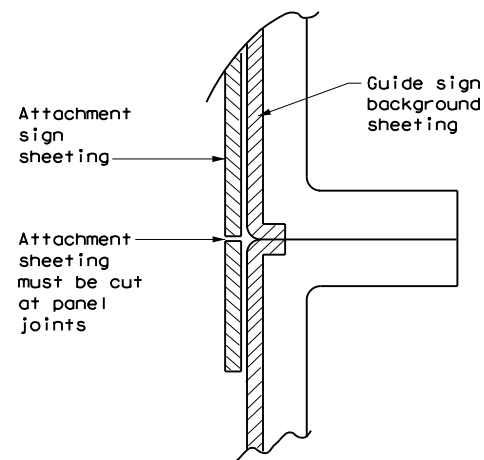

DIRECT APPLIED ATTACHMENT

NOTE:

- Sheeting for legend, symbols, and borders must be cut at panel joints.
- Direct applied attachment signs will be subsidiary to "Aluminum Signs" or "Fiberglass Signs".

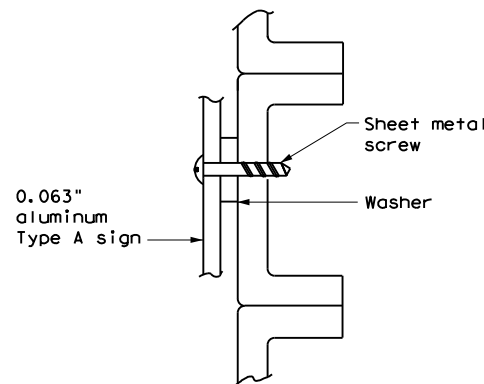

SCREW ATTACHMENT

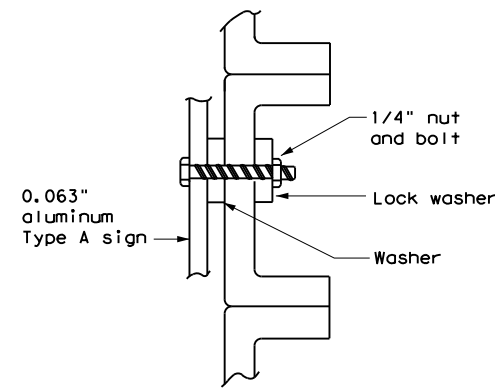

NUT/BOLT ATTACHMENT

NOTE:

Furnish Type A aluminum sign attachments only when specified in the plans. These signs will be paid for under "Aluminum Signs".

ARROW DETAILS for Destination Signs (Type D)

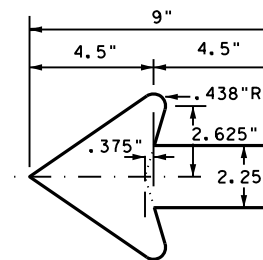

Standard arrow to be used with 6 inch letters.

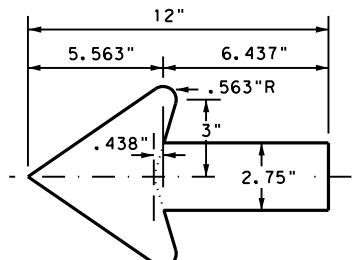

Standard arrow to be used with 8 inch letters.

TYPICAL SIGN REQUIREMENTS

TSR (5) - 13

FILE: tsr5-13.dgn	DW: TxDOT	CK: TxDOT	DW: TxDOT	CK: TxDOT
© TxDOT October 2003	CONT	SECT	JOB	HIGHWAY
REVISIONS	0095	14	033, ETC	IH 20, ETC
12-03 7-13	DIST	COUNTY	SHEET NO.	
9-08	DAL	KAUFMAN, ETC	278	

DATE: 3/1/2023 4:32:05 PM
 FILE: T:\DAL\TRAFFIC\2023 PS&E\I.H. 20\Plan_Set\Standards\non-paf_standards.dwg
 DISCLAIMER: The use of this standard is governed by the "Texas Engineering Practice Act". No warranty of any kind is made by TxDOT for any purpose whatsoever. TxDOT assumes no responsibility for the conversion of other formats or for incorrect results or damages resulting from its use.

REFLECTOR UNIT SIZES FOR DELINEATORS AND OBJECT MARKERS				DELINEATORS				D & OM DESCRIPTIVE CODES	
DEVICE	SIZE 1	SIZE 2	SIZE 3	SIZE 4	SINGLE		DOUBLE		INSTL DEL ASSM (D-XX)SZ X (XXXX)XXX(XX) NUMBER OF REFLECTORS S = Single D = Double COLOR OF REFLECTORS W = White Y = Yellow R = Red REFLECTOR UNIT SIZE 1 or 2 TYPE OF POST OR DELINEATOR WC = Wing Channel Post YFLX = Yellow Flexible Post WFLX = White Flexible Post BRF = Barrier Reflector TYPE OF MOUNT GND = Embedded (drivable or set in concrete) CTB = Concrete Barrier Mount GF1 or GF2 = Guard Fence Attachment SRF = Surface Mount DIRECTION If Required BI = Bi-Directional BR = Bi-Directional with red on back
						SHEETING Yellow, White or Red Type B or C reflective sheeting NOTE 1. Size 1 and 4 - Direct applied reflective sheeting for use on flexible post (fix). 2. Size 2 and 3 - For use on wing channel (wc) post only. Use approved metal, plastic or fiberglass backplate with 17/64" mounting holes.			
				SHEETING Yellow, White or Red Type B or C Reflective Sheeting		SHEETING Yellow, White or Red Type B or C Reflective Sheeting			
				POST TYPE WC	YFLX, WFLX	WC	YFLX, WFLX	INSTL OM ASSM (OM-XX) (XXXX)XXX(XX) TYPE OF OBJECT MARKER 1, 2, 3, or 4 NUMBER OF REFLECTORS OR DIRECTION X = 3-Size 2 reflector unit (Type 2 only) Y = 1-Size 3 reflector unit (Type 2 only) Z = 3-Size 1 or 1-Size 4 reflector unit(s) (Type 2 only) L = Left Side (Type 3 Object Marker only) R = Right Side (Type 3 Object Marker only) C = Center (Type 3 Object Marker only) TYPE OF POST WC = Wing Channel Post WFLX = White Flexible Post TWT = Thin Walled Tubing TYPE OF MOUNT GND = Embedded (drivable) SRF = Surface Mount WAS = Wedge Anchor Steel WAP = Wedge Anchor Plastic DIRECTION If Required BI = Bi-Directional	
				MOUNT TYPE GND	GND, SRF	GND	GND, SRF		

OBJECT MARKERS								
DEVICE	Type 1 (OM-1)	Type 2 (OM-2)			Type 3 (OM-3)			Type 4 (OM-4)
	OM-1	OM-2X	OM-2Y	OM-2Z	OM-3L	OM-3R	OM-3C	OM-4
SHEETING Yellow-Type B _{FL} or C _{FL} Sheeting		SHEETING Yellow - Type B or C Sheeting			SHEETING Alternating acrylic black and retroreflective yellow - Type B _{FL} or C _{FL} Sheeting			SHEETING Red -Type B _{FL} or C _{FL} Sheeting
POST TYPE TWT		WC	WC	WFLX	TWT			TWT
MOUNT TYPE WAS, WAP		GND	GND	GND, SRF	WAS, WAP			WAS, WAP



DEPARTMENTAL MATERIAL SPECIFICATIONS	
FLEXIBLE DELINEATOR & OBJECT MARKER POSTS (EMBEDDED & SURFACE MOUNT TYPES)	DMS-4400
SIGN FACE MATERIALS	DMS-8300
DELINEATORS, OBJECT MARKERS AND BARRIER REFLECTORS	DMS-8600

BARRIER REFLECTORS (BRF)			CHEVRONS				ONE DIRECTION LARGE ARROW		NOTE: Delineator and object marker substrates and sign substrates shall be 0.080" Aluminum sign blank to conform to ASTM B-209 Alloy 6061-T6 or approved alternative.
DEVICE	GF1	GF2	CTB	W1-8				W1-6	
SHEETING Yellow, White, Red NOTE 1. Barrier reflectors shall meet the requirements of DMS 8600. 2. Approved Barrier Reflectors are listed on the "Barrier Reflectors" Material Producer List at: www.txdot.gov.			SIZE (W x L) 18" x 24" (Conventional) 24" x 30" (Conventional Oversize) 30" x 36" (Expressway) 36" x 48" (Freeway)				SIZE (W x L) 48" x 24" (Conventional) 60" x 30" (Expressway & Freeway)		Traffic Safety Division Standard DELINEATOR & OBJECT MARKER MATERIAL DESCRIPTION D & OM(1)-20
			MOUNTING HEIGHT 4'-0" or 7'-0"				MOUNTING HEIGHT 7'-0"		
			NOTE 1. CHEVRON (W1-8) signs and ONE DIRECTION LARGE ARROW (W1-6) Signs shall be installed per Sign Mounting Details (SMD) Standard Sheets and paid under Item 644 (Small Roadside Sign Assemblies). 2. When there is a need to increase conspicuity, the Texas version of the ONE DIRECTION LARGE ARROW sign (W1-9T) may be used instead of the ONE DIRECTION LARGE ARROW (W1-6).						

FILE: dom1-20.dgn	DN: TXDOT	CK: TXDOT	OW: TXDOT	CR: TXDOT
© TXDOT August 2004	CONT	SECT	JOB	HIGHWAY
REVISIONS	0095	14	033, ETC	IH 20, ETC
10-09 3-15	DIST	COUNTY	SHEET NO.	
4-10 7-20	DAL	KAUFMAN, ETC		279

DISCLAIMER: The use of this standard is governed by the "Texas Engineering Practice Act". No warranty of any kind is made by TxDOT for any purpose whatsoever. TxDOT assumes no responsibility for the conversion of this standard to other formats or for incorrect results or damages resulting from its use.

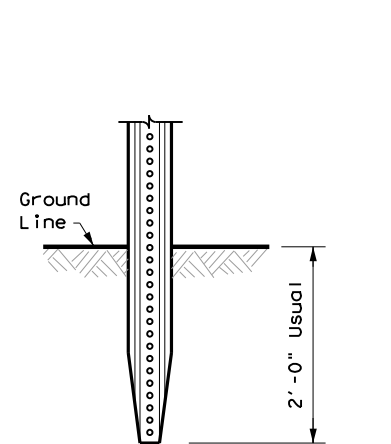
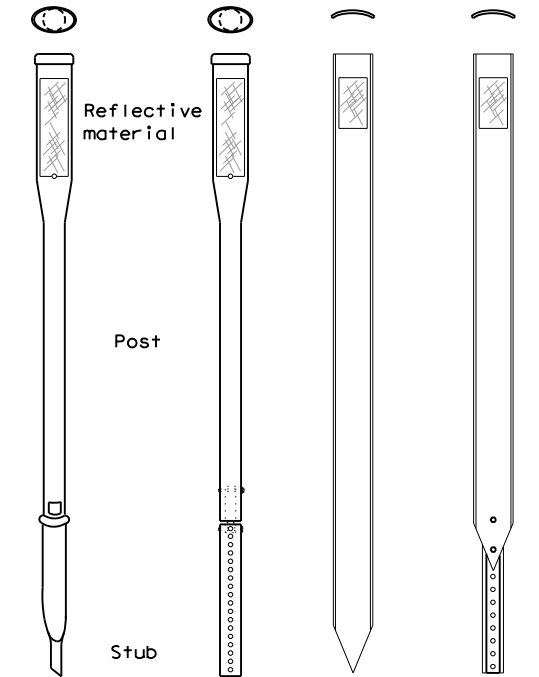
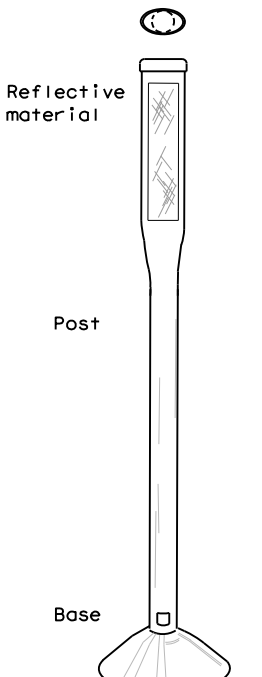
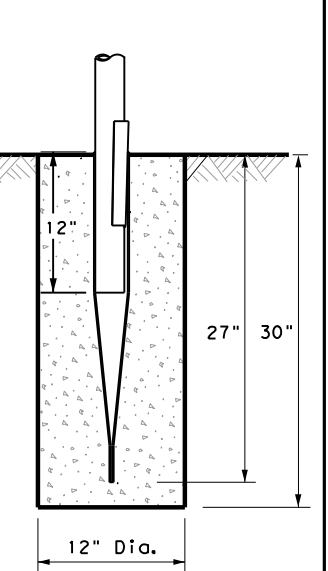
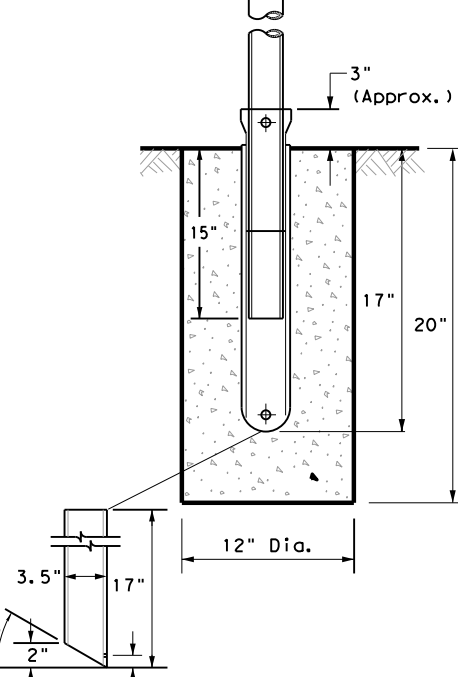
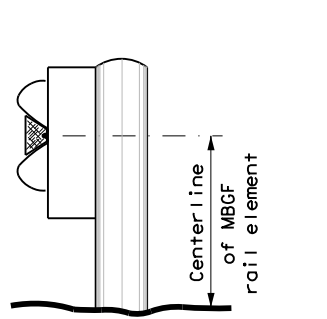
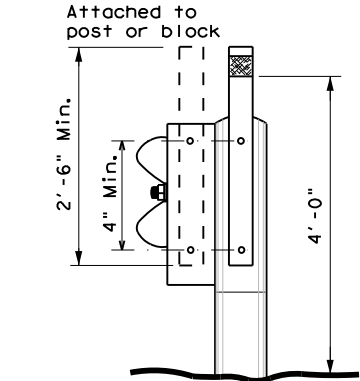
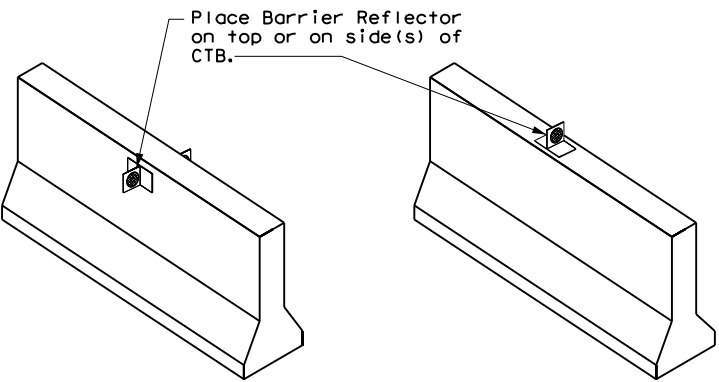
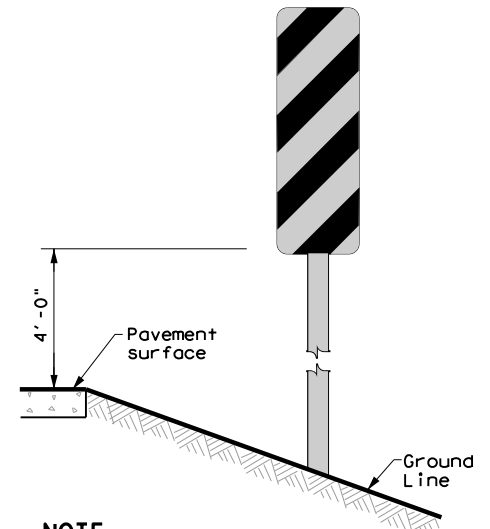
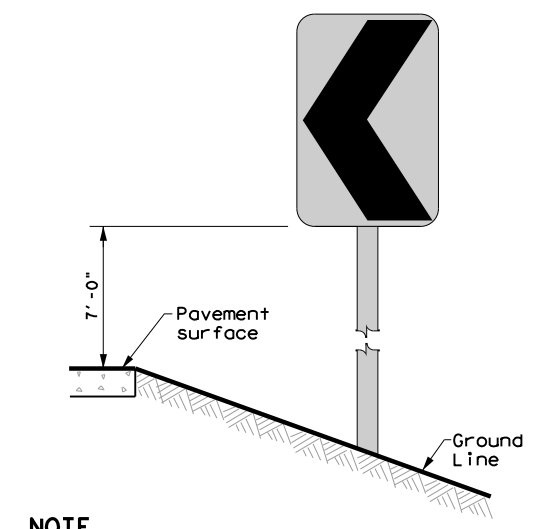
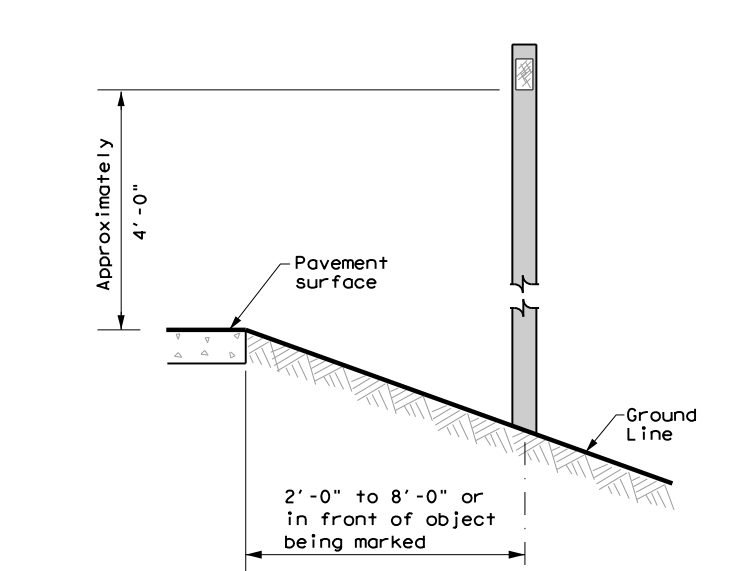
DATE: 3/1/2023 4:32:06 PM
 FILE: T:\DAL\TRAFFIC\2023 PS&E\1H_20\Plan_Set\Standards\non-paf_standards\200 Delineator.dwg

POST TYPE AND SUPPORT FOUNDATION DETAILS				TYPE OF BARRIER MOUNTS																										
WING CHANNEL (WC)	FLEXIBLE POSTS (YFLX, WFLX)		WEDGE ANCHOR SYSTEMS		GUARD FENCE ATTACHMENT																									
GND	GND	SRF	WAS	WAP	GF 1																									
 <p style="text-align: center;">2'-0" Usual</p>																														
	EMBEDDED	SURFACE MOUNT	STEEL	PLASTIC	CONCRETE TRAFFIC BARRIER (CTB)																									
NOTES 1. Embedded Wing Channel (WC) post option may be used for Type 2 Object Markers and Delineators only. 2. 1.12 lbs/ft steel per ASTM A 1011 SS Gr. 50, or ASTM A499.	NOTES 1. See "Flexible Delineator and Object Marker Posts" Material Producer List for approved devices. 2. Install per manufacturer's recommendations. 3. Post length may vary to meet field conditions. 4. When using yellow delineators with flexible posts to separate opposing direction of travel, such as centerline or median use, the flexible posts shall be yellow.		NOTE 1. Install per manufacturer's recommendations.																											
TYPES 1,3, AND 4 OBJECT MARKERS AND CHEVRONS		CHEVRONS AND ONE DIRECTION LARGE ARROW SIGN		DELINEATORS AND TYPE 2 OBJECT MARKERS																										
																														
NOTE Mounting at 4 feet to the bottom of the chevron is permitted for chevrons that will not exceed a height of 6'-6" to the top of the chevron (sizes 24" x 30" and smaller)		NOTE Chevrons 30" x 36" and larger shall be mounted at a height of 7' to the bottom of the chevron. Chevron sign and ONE DIRECTION LARGE ARROW sign (W1-9T) shall be installed per SMD standard sheets and paid under item 644.		NOTE See general notes 1, 2 and 3.																										
GENERAL NOTES 1. Place delineators on a section of roadway at a consistent distance from the edge of pavement. 2. Where a restriction prevents consistent placement from the pavement edge, place the affected object markers in line with the innermost edge of the obstruction. 3. When Type 2 object markers and delineators are more than 8'-0" from the edge of the pavement, it may not be possible to maintain a height of approximately 4'-0". If this is the case, place the object marker or delineator as close to the desired height as possible. 4. Install all delineators, object markers and barrier reflectors in accordance with the manufacturer's recommendation. 5. Barrier reflectors should be installed a minimum of 18 inches above the edge of the pavement surface. 6. Diagonal stripes on Type 3 object markers shall slope down toward the intended travel lane.																														
 Traffic Safety Division Standard																														
<h2 style="margin: 0;">DELINEATOR & OBJECT MARKER INSTALLATION</h2> <h3 style="margin: 0;">D & OM(2)-20</h3>																														
<table border="1" style="width: 100%; border-collapse: collapse; font-size: small;"> <tr> <td>FILE: dom2-20.dgn</td> <td>DN: TxDOT</td> <td>CK: TxDOT</td> <td>DW: TxDOT</td> <td>CK: TxDOT</td> </tr> <tr> <td>© TxDOT August 2004</td> <td>CONT</td> <td>SECT</td> <td>JOB</td> <td>HIGHWAY</td> </tr> <tr> <td>REVISIONS</td> <td>0095 14</td> <td></td> <td>033, ETC</td> <td>IH 20, ETC</td> </tr> <tr> <td>10-09 3-15</td> <td>DIST</td> <td>COUNTY</td> <td colspan="2">SHEET NO.</td> </tr> <tr> <td>4-10 7-20</td> <td>DAL</td> <td>KAUFMAN, ETC</td> <td colspan="2" style="text-align: right;">280</td> </tr> </table>						FILE: dom2-20.dgn	DN: TxDOT	CK: TxDOT	DW: TxDOT	CK: TxDOT	© TxDOT August 2004	CONT	SECT	JOB	HIGHWAY	REVISIONS	0095 14		033, ETC	IH 20, ETC	10-09 3-15	DIST	COUNTY	SHEET NO.		4-10 7-20	DAL	KAUFMAN, ETC	280	
FILE: dom2-20.dgn	DN: TxDOT	CK: TxDOT	DW: TxDOT	CK: TxDOT																										
© TxDOT August 2004	CONT	SECT	JOB	HIGHWAY																										
REVISIONS	0095 14		033, ETC	IH 20, ETC																										
10-09 3-15	DIST	COUNTY	SHEET NO.																											
4-10 7-20	DAL	KAUFMAN, ETC	280																											

DISCLAIMER: The use of this standard is governed by the "Texas Engineering Practice Act". No warranty of any kind is made by TxDOT for any purpose whatsoever. TxDOT assumes no responsibility for the conversion of units or for incorrect results or damages resulting from its use.

DATE: 3/11/2023 4:32:06 PM
 FILE: T:\DAL\TRAFFIC\2023_P&E\I\H_20\Plan_Set\Standards\non-paf_standards.dwg

MINIMUM WARNING DEVICES AT CURVES WITH ADVISORY SPEEDS

Amount by which Advisory Speed is less than Posted Speed	Curve Advisory Speed	
	Turn (30 MPH or less)	Curve (35 MPH or more)
5 MPH & 10 MPH	• RPMs	• RPMs
15 MPH & 20 MPH	• RPMs and One Direction Large Arrow sign	• RPMs and Chevrons; or • RPMs and One Direction Large Arrow sign where geometric conditions or roadside obstacles prevent the installation of chevrons.
25 MPH & more	• RPMs and Chevrons; or • RPMs and One Direction Large Arrow sign where geometric conditions or roadside obstacles prevent the installation of chevrons	• RPMs and Chevrons

SUGGESTED SPACING FOR DELINEATORS ON HORIZONTAL CURVES

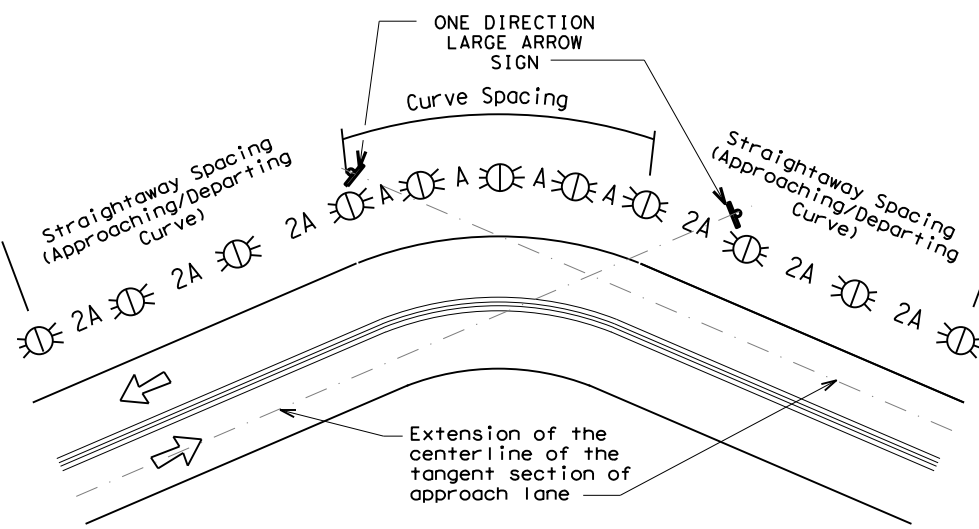

NOTE

ONE DIRECTION LARGE ARROW (W1-6) sign should be located at approximately and perpendicular to the extension of the centerline of the tangent section of approach lane.

SUGGESTED SPACING FOR CHEVRONS ON HORIZONTAL CURVES

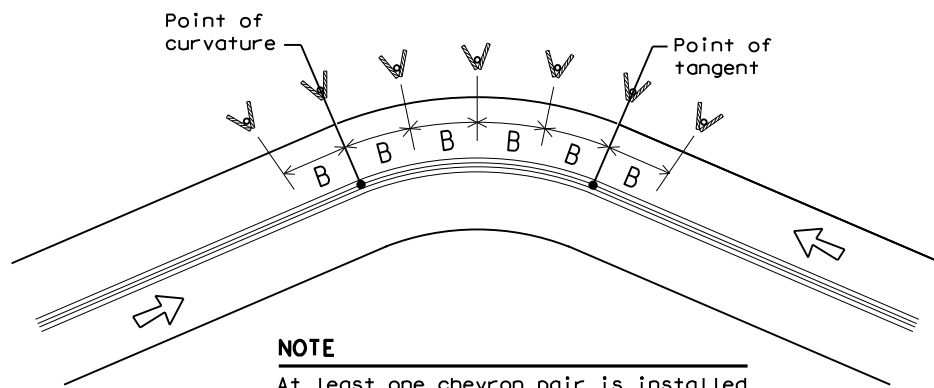

NOTE

At least one chevron pair is installed beyond the point of tangent in tangent section.

DELINEATOR AND CHEVRON SPACING

WHEN DEGREE OF CURVE OR RADIUS IS KNOWN				
Degree of Curve	FEET			
	Radius of Curve	Spacing in Curve	Spacing in Straightaway	Chevron Spacing in Curve
		A	2A	B
1	5730	225	450	—
2	2865	160	320	—
3	1910	130	260	200
4	1433	110	220	160
5	1146	100	200	160
6	955	90	180	160
7	819	85	170	160
8	716	75	150	160
9	637	75	150	120
10	573	70	140	120
11	521	65	130	120
12	478	60	120	120
13	441	60	120	120
14	409	55	110	80
15	382	55	110	80
16	358	55	110	80
19	302	50	100	80
23	249	40	80	80
29	198	35	70	40
38	151	30	60	40
57	101	20	40	40

Curve delineator approach and departure spacing should include 3 delineators spaced at 2A. This spacing should be used during design preparation or when the degree of curve is known.

DELINEATOR AND CHEVRON SPACING

WHEN DEGREE OF CURVE OR RADIUS IS NOT KNOWN			
Advisory Speed (MPH)	Spacing in Curve	Spacing in Straightaway	Chevron Spacing in Curve
	A	2xA	B
65	130	260	200
60	110	220	160
55	100	200	160
50	85	170	160
45	75	150	120
40	70	140	120
35	60	120	120
30	55	110	80
25	50	100	80
20	40	80	80
15	35	70	40

If the degree of curve is not known, delineator spacing may be determined based on the Advisory Speed of the curve. Use the delineator curve spacing for each Advisory Speed (MPH).

DELINEATOR AND OBJECT MARKER APPLICATION AND SPACING

CONDITION	REQUIRED TREATMENT	MINIMUM SPACING
Frwy./Exp. Tangent	RPMs	See PM-series and FPM-series standard sheets
Frwy./Exp. Curve	Single delineators on right side	See delineator spacing table
Frwy/Exp. Ramp	Single delineators on at least one side of ramp (should be on outside of curves) (see Detail 3 on D&OM(4))	100 feet on ramp tangents Use delineator spacing table for ramp curves ("straightway spacing" does not apply to ramp curves)
Acceleration/Deceleration Lane	Double delineators (see Detail 3 on D&OM(4))	100 feet (See Detail 3 on D & OM (4))
Truck Escape Ramp	Single red delineators on both sides	50 feet
Bridge Rail (steel or concrete) and Metal Beam Guard Fence	Bi-Directional Delineators when undivided with one lane each direction Single Delineators when multiple lanes each direction	Equal spacing (100' max) but not less than 3 delineators
Concrete Traffic Barrier (CTB) or Steel Traffic Barrier	Barrier reflectors matching the color of the edge line	Equal spacing 100' max
Cable Barrier	Reflectors matching the color of the edge line	Every 5th cable barrier post (up to 100' max)
Guard Rail Terminus/Impact Head	Divided highway - Object marker on approach end Undivided 2-lane highways - Object marker on approach and departure end	Requires reflective sheeting provided by manufacturer per D & OM (VIA) or a Type 3 Object Marker (OM-3) in front of the terminal end See D & OM (5) and D & OM (6)
Bridges with no Approach Rail	Type 3 Object Marker (OM-3) at end of rail and 3 single delineators approaching rail	See D & OM(5)
Reduced Width Approaches to Bridge Rail	Type 2 and Type 3 Object Markers (OM-3) and 3 single delineators approaching bridge	Requires reflective sheeting provided by manufacturer per D & OM (VIA) or a Type 3 Object Marker (OM-3) in front of the terminal end See D & OM (5)
Culverts without MBGF	Type 2 Object Markers	See Detail 2 on D & OM(4)
Crossovers	Double yellow delineators and RPMs	See Detail 1 on D & OM (4)
Pavement Narrowing (lane merge) on Freeways/Expressway	Single delineators adjacent to affected lane for full length of transition	100 feet

NOTES

- Unless indicated otherwise, the delineator or barrier reflector color shall conform to the color of the pavement edge line on the side of the road where the delineators or barrier reflectors are placed.
- Barrier reflectors may be used to replace required delineators.
- Single red delineators may be mounted on the back side of delineator posts for wrong way driver applications

LEGEND	
	Bi-directional Delineator
	Delineator
	Sign

Traffic Safety Division Standard

DELINEATOR & OBJECT MARKER PLACEMENT DETAILS

D & OM(3)-20

FILE: dom3-20.dgn	DW: TXDOT	CK: TXDOT	OW: TXDOT	CR: TXDOT
© TXDOT August 2004	CONT	SECT	JOB	HIGHWAY
REVISIONS	0095 14	033, ETC		IH 20, ETC
3-15 8-15	DIST	COUNTY	SHEET NO.	
8-15 7-20	DAL	KAUFMAN, ETC	281	

20C

DISCLAIMER: The use of this standard is governed by the "Texas Engineering Practice Act". No warranty of any kind is made by TxDOT for any purpose whatsoever. TxDOT assumes no responsibility for the conversion of this standard to other formats or for incorrect results or damages resulting from its use.

DATE: 3/1/2023 4:32:07 PM
 FILE: T:\DAL\TRAFFIC\2023 PS&E\1H 20\Plan_Set\Standards\non-paf_standards.dwg

CONTINUOUS CONCRETE OR STEEL BARRIER

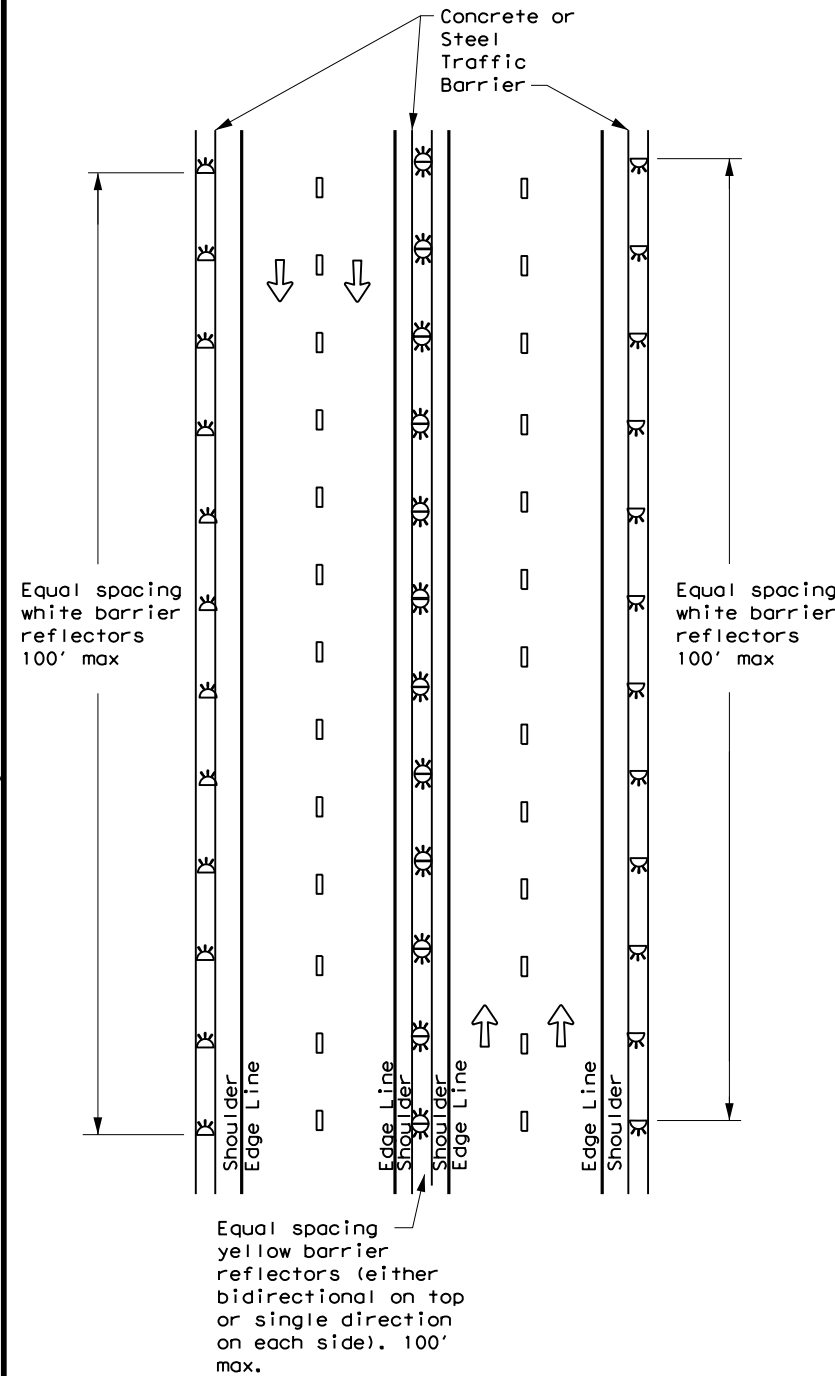

MULTI-LANE UNDIVIDED, TWO-WAY ROADWAY WITH METAL BEAM GUARD FENCE (MBGF)

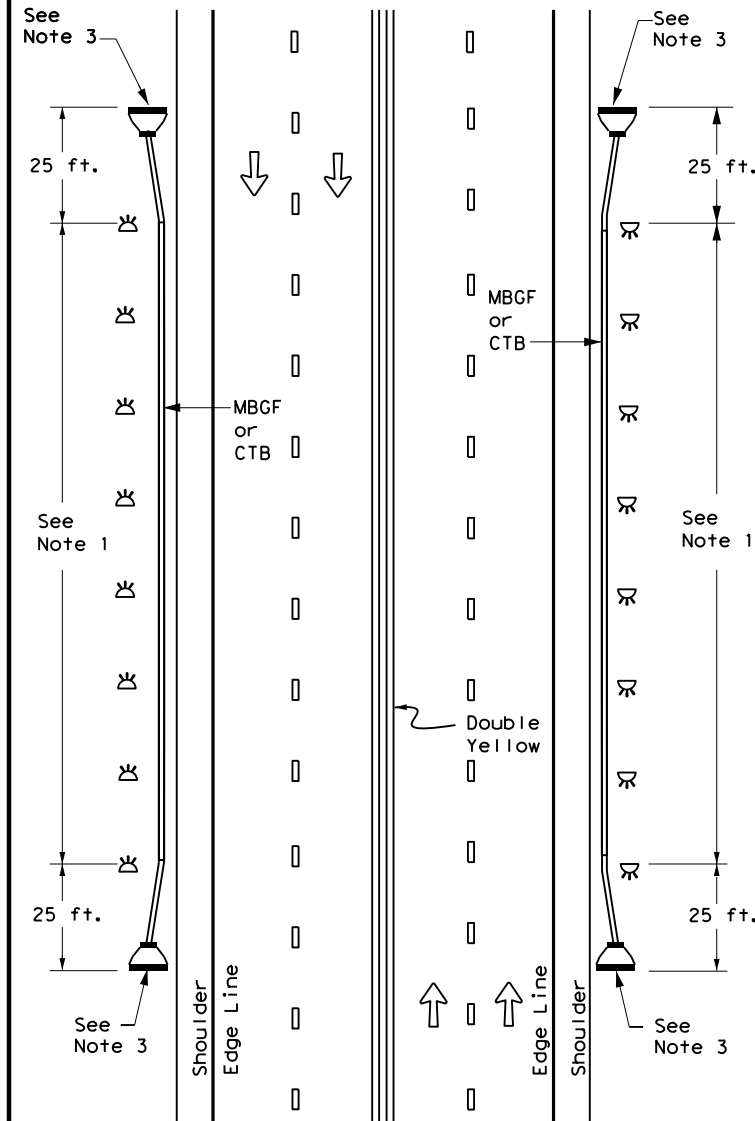

DIVIDED ROADWAY WITH METAL BEAM GUARD FENCE (MBGF)

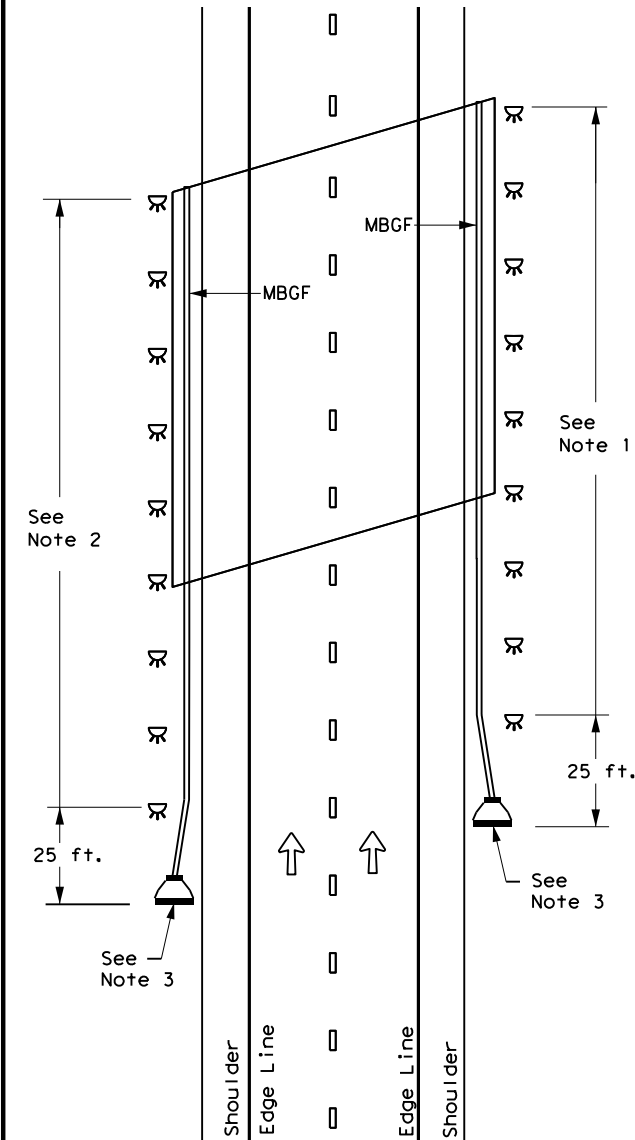

EMERGENCY CROSSOVER

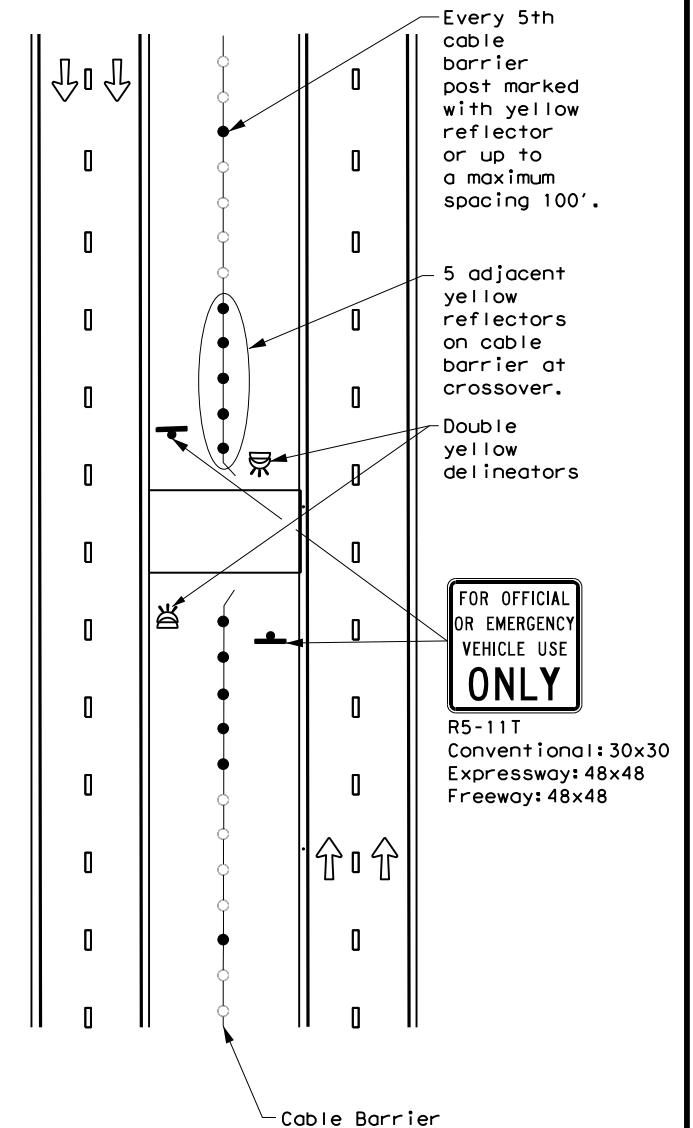

NOTES

1. Equal spacing (100' max), but not less than 3 single directional white barrier reflectors or delineators. On Continuous Barrier, equal spacing (100' max.)
2. Equal spacing (100' max), but not less than 3 single directional yellow barrier reflectors or delineators.
3. Terminal ends require reflective sheeting provided by manufacturer per D & OM (VIA) or a Type 3 Object Marker (OM-3) in front of the terminal end.

LEGEND

	Bidirectional Delineator
	Delineator
	OM-3
	OM-2
	Terminal End
	Traffic Flow



DELINEATOR & OBJECT MARKER PLACEMENT DETAILS

D & OM(6)-20

FILE: dom6-20.dgn	DN: TxDOT	CK: TxDOT	DW: TxDOT	CK: TxDOT
© TxDOT August 2015	CONT	SECT	JOB	HIGHWAY
REVISIONS	0095	14	033, ETC	IH 20, ETC
7-20	DIST	COUNTY	SHEET NO.	
	DAL	KAUFMAN, ETC	282	

DISCLAIMER: The use of this standard is governed by the "Texas Engineering Practice Act". No warranty of any kind is made by TxDOT for any purpose whatsoever. TxDOT assumes no responsibility for the conversion of this standard to other formats or for incorrect results or damages resulting from its use.

DATE: 3/1/2023 4:32:08 PM
 FILE: T:\DAL\TRAFFIC\2023 PS&E\I.H. 20\Plan_Set\Standards\non-paf_standards\283_SMD(GEN)-08.dgn

SIGN SUPPORT DESCRIPTIVE CODES

(Descriptive Codes correspond to project estimate and quantities sheets)

SM RD SGN ASSM TY XXXXX(X)XX(X-XXXX)

Post Type

- FRP = Fiberglass Reinforced Plastic Pipe (see SMD(FRP))
- TWT = Thin-Walled Tubing (see SMD(TWT))
- 10BWG = 10 BWG Tubing (see SMD(SLIP-1) to (SLIP-3))
- S80 = Schedule 80 Pipe (see SMD(SLIP-1) to (SLIP-3))

Number of Posts (1 or 2)

Anchor Type

- UA = Universal Anchor - Concreted (see SMD(FRP) and (TWT))
- UB = Universal Anchor - Bolted down (see SMD(FRP) and (TWT))
- WS = Wedge Anchor Steel - (see SMD(TWT))
- WP = Wedge Anchor Plastic (see SMD(TWT))
- SA = Slipbase - Concreted (see SMD(SLIP-1) to (SLIP-3))
- SB = Slipbase - Bolted Down (see SMD(SLIP-1) to (SLIP-3))

Sign Mounting Designation

- P = Prefab. "Plain" (see SMD(SLIP-1) to (SLIP-3), (TWT), (FRP))
- T = Prefab. "T" (see SMD(SLIP-1) to (SLIP-3), (TWT))
- U = Prefab. "U" (see SMD(SLIP-1) to (SLIP-3))

IF REQUIRED

- 1EXT or 2EXT = Number of Extensions (see SMD(SLIP-1) to (SLIP-3), (TWT))
- BM = Extruded Wind Beam (see SMD(SLIP-1) to (SLIP-3))
- WC = 1.12 #/ft Wing Channel (see SMD(SLIP-1) to (SLIP-3))
- EXAL = Extruded Aluminum Sign Panels (see SMD(SLIP-3))

REQUIRED CLEARANCE FOR BREAKAWAY SUPPORT

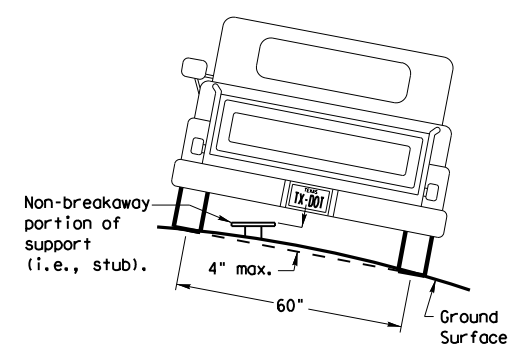

To avoid vehicle undercarriage snagging, any substantial remains of a breakaway support, when it is broken away, should not project more than 4 inches above a 60-inch chord (i.e., typical space between wheel paths).

SIGN LOCATION

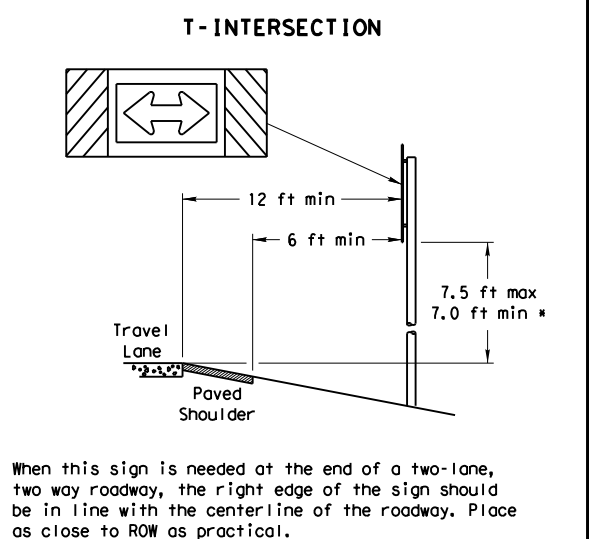
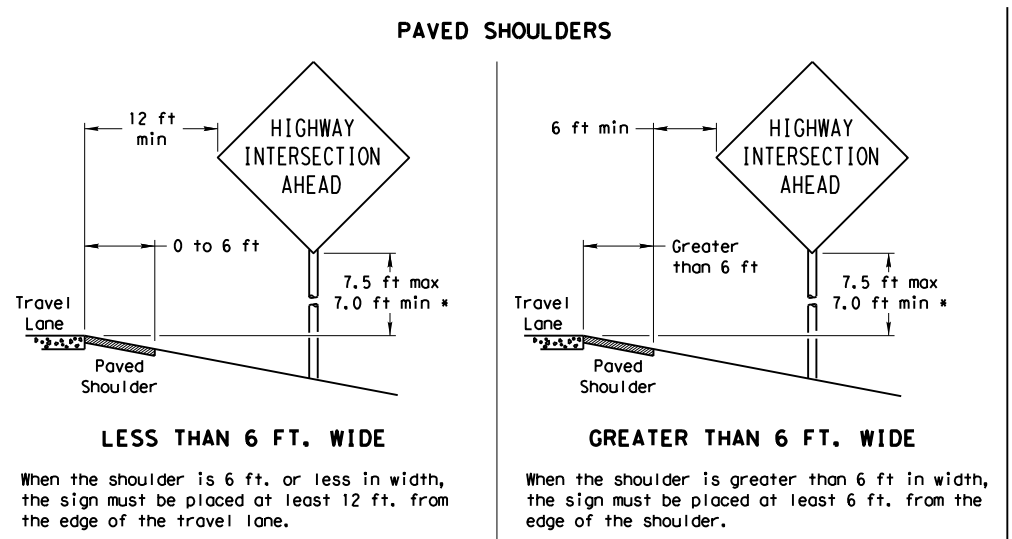

No more than 2 sign posts should be located within a 7 ft. circle.

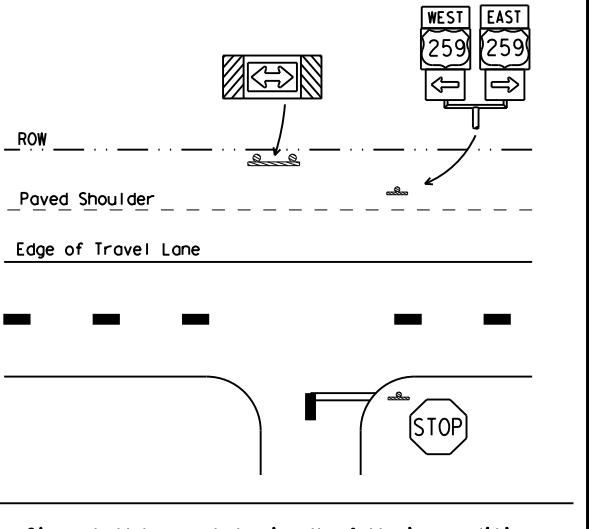
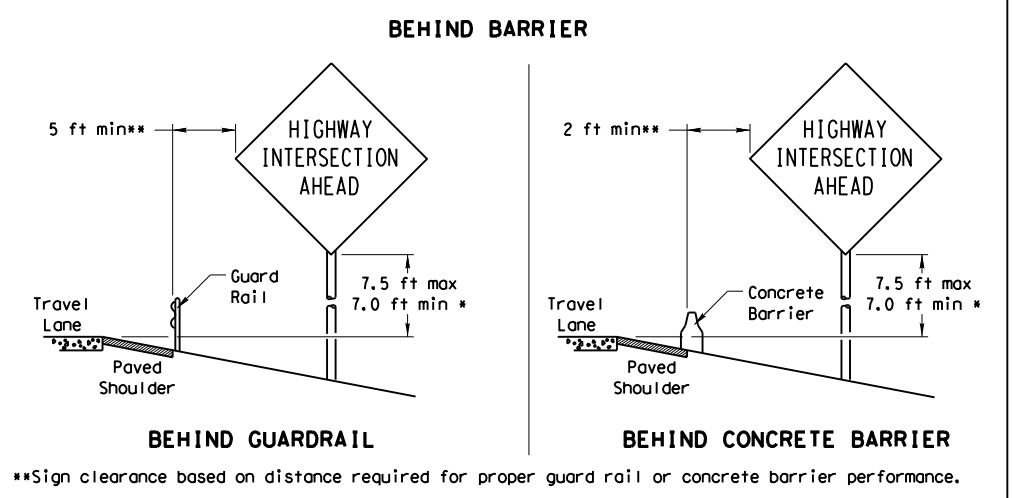
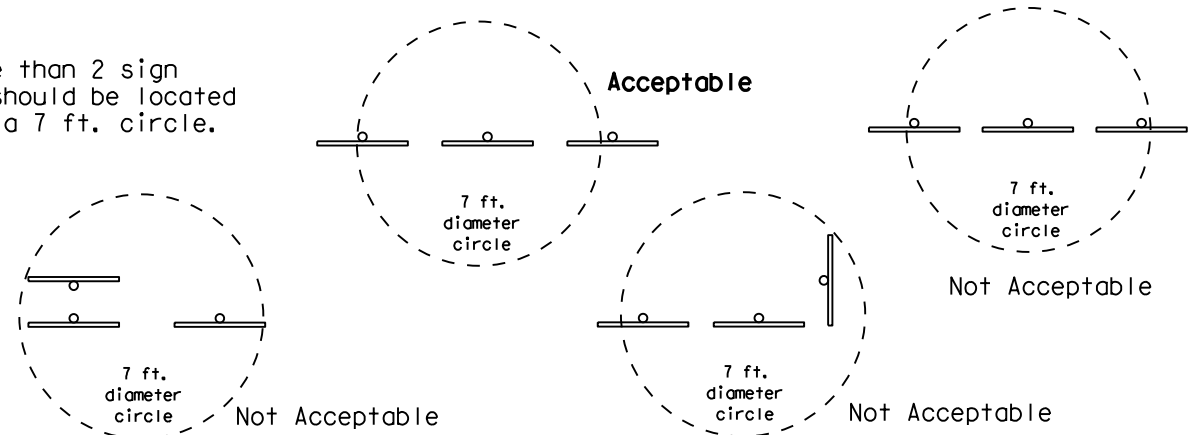

TYPICAL SIGN ATTACHMENT DETAIL

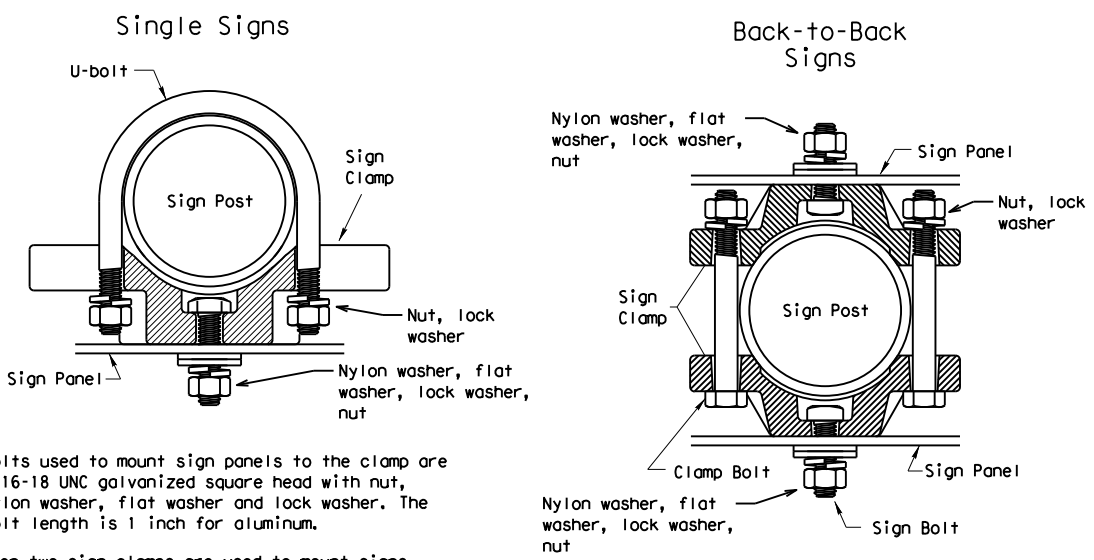

Bolts used to mount sign panels to the clamp are 5/16-18 UNC galvanized square head with nut, nylon washer, flat washer and lock washer. The bolt length is 1 inch for aluminum.

When two sign clamps are used to mount signs back-to-back, use a 5/16-18 UNC galvanized hex head per ASTM A307 with nut and helical-spring lock washer. The approximate bolt lengths for various post sizes and sign clamp types are given in the table at right. The bolt length may need to be adjusted depending upon field conditions.

Pipe Diameter	Approximate Bolt Length	
	Specific Clamp	Universal Clamp
2" nominal	3"	3 or 3 1/2"
2 1/2" nominal	3 or 3 1/2"	3 1/2 or 4"
3" nominal	3 1/2 or 4"	4 1/2"

Sign clamps may be either the specific size clamp or the universal clamp.

SIGNS WITH PLAQUES

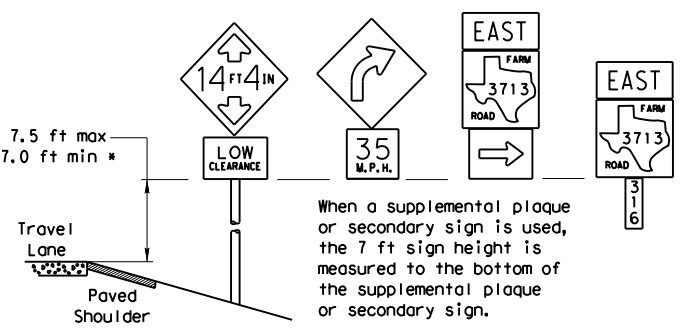

When a supplemental plaque or secondary sign is used, the 7 ft sign height is measured to the bottom of the supplemental plaque or secondary sign.

CURB & GUTTER OR RAISED ISLAND

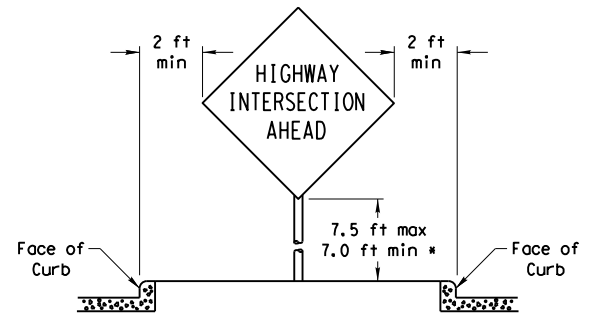

RESTRICTED RIGHT-OF-WAY (When 6 ft min. is not possible.)

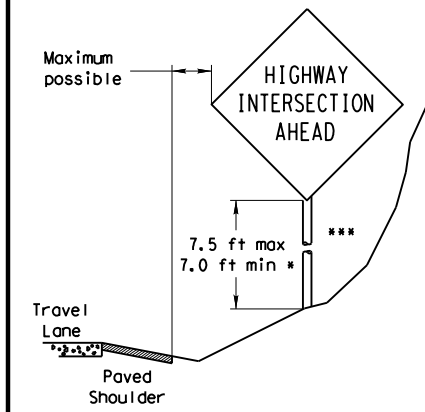

Right-of-way restrictions may be created by rocks, water, vegetation, forest, buildings, a narrow island, or other factors.

In situations where a lateral restriction prevents the minimum horizontal clearance from the edge of the travel lane, signs should be placed as far from the travel lane as practical.

*** Post may be shorter if protected by guardrail or if Engineer determines the post could not be hit due to extreme slope.

Signs shall be mounted using the following condition that results in the greatest sign elevation:

- a minimum of 7 to a maximum of 7.5 feet above the edge of the travel lane or
- a minimum of 7 to a maximum of 7.5 feet above the grade at the base of the support when sign is installed on the backslope.

The maximum values may be increased when directed by the Engineer.

See the Traffic Operations Division website for detailed drawings of sign clamps, Triangular Slipbase System components and Wedge Anchor System components.

The website address is:
<http://www.txdot.gov/publications/traffic.htm>

Texas Department of Transportation
Traffic Operations Division

SIGN MOUNTING DETAILS

SMALL ROADSIDE SIGNS

GENERAL NOTES & DETAILS

SMD(GEN)-08

© TxDOT July 2002		DN: TxDOT	CK: TxDOT	DW: TxDOT	CK: TxDOT
9-08	REVISIONS	CONT	SECT	JOB	HIGHWAY
		0095	14	033, ETC	IH 20, ETC
		DIST	COUNTY		SHEET NO.
		DAL	KAUFMAN, ETC		283

DISCLAIMER: The use of this standard is governed by the "Texas Engineering Practice Act". No warranty of any kind is made by TxDOT for any purpose whatsoever. TxDOT assumes no responsibility for the conversion of this standard to other formats or for incorrect results or damages resulting from its use.

DATE: 3/1/2023 4:32:08 PM
 FILE: T:\DAL\TRAFFIC\FY 2023_PS&E_IH_20\Plan_Set\Standards\non-paf_standards\SMD(SLIP-1)-08(DAL).dgn

TRIANGULAR SLIPBASE INSTALLATION GENERAL REQUIREMENTS

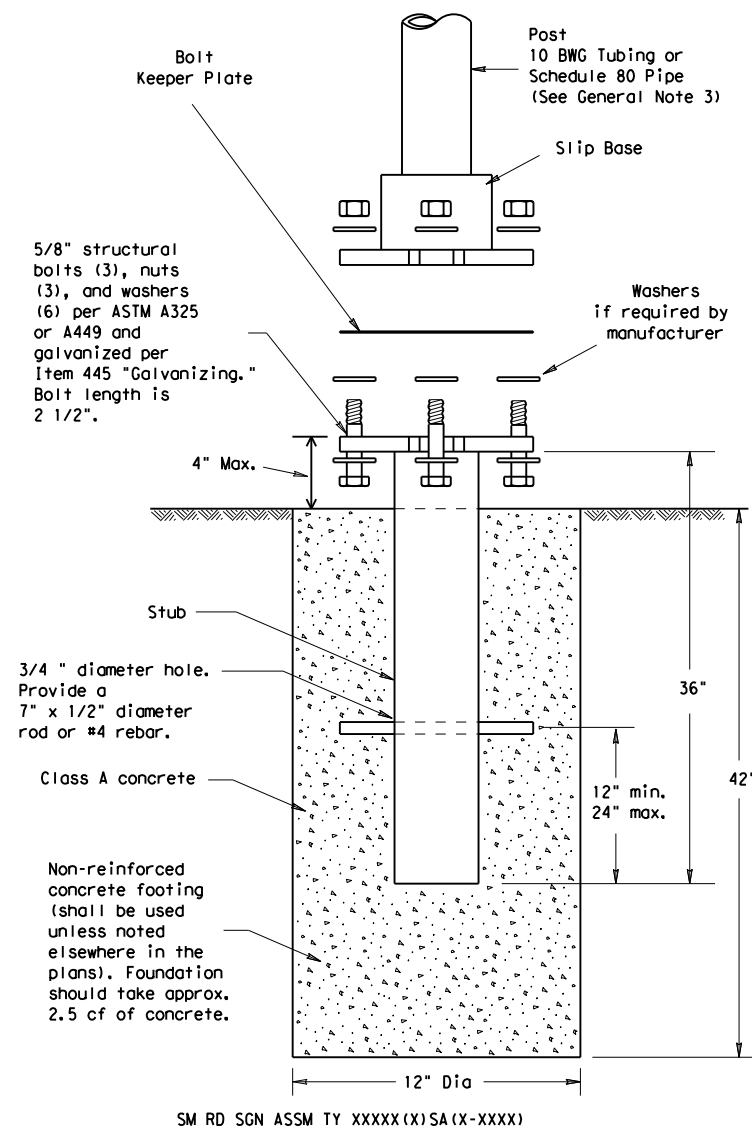

SM RD SGN ASSM TY XXXXX(X)SA(X-XXXX)

NOTE
 The devices shall be installed per manufacturers' recommendations. Installation procedures shall be provided to the Engineer by Contractor.

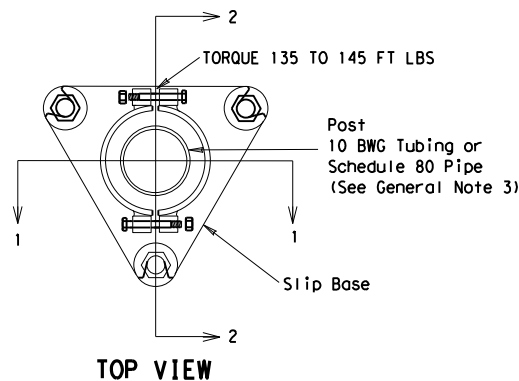
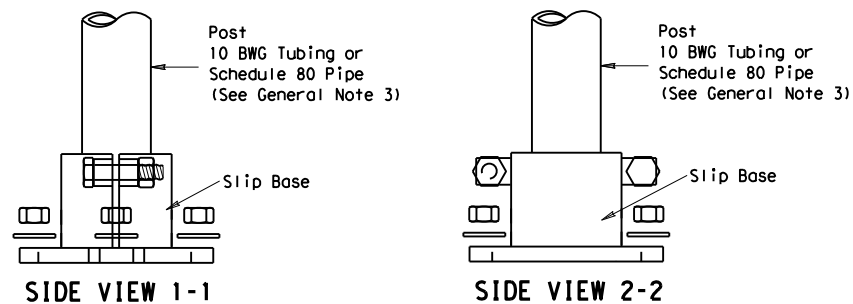

TOP VIEW

DETAIL A

CONCRETE ANCHOR

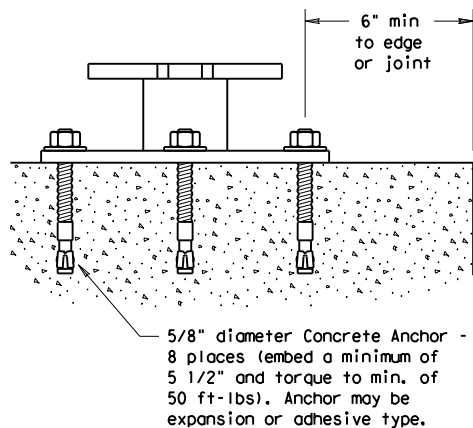

SM RD SGN ASSM TY XXXXX(X)SB(X-XXXX)

Concrete anchor consists of 5/8" diameter stud bolt with UNC series bolt threads on the upper end. Heavy hex nut per ASTM A563, and hardened washer per ASTM F436. The stud bolt shall have a minimum yield and ultimate tensile strength of 50 and 75 KSI, respectively. Nuts, bolts and washers shall be galvanized per Item 445, "Galvanizing." Adhesive type anchors shall have stud bolts installed with Type III epoxy per DMS-6100, "Epoxyes and Adhesives." Adhesive anchors may be loaded after adequate epoxy cure time per the manufacturer's recommendations. Top of bolt shall extend at least flush with top of the nut when installed. The anchor, when installed in 4000 psi normal-weight concrete with a 5 1/2" minimum embedment, shall have a minimum allowable tension and shear of 3900 and 3100 psi, respectively.

GENERAL NOTES:

- Slip base shall be permanently marked to indicate manufacturer. Method, design, and location of marking are subject to approval of the TxDOT Traffic Standards Engineer.
- Material used as post with this system shall conform to the following specifications:
 - 10 BWG Tubing (2.875" outside diameter)
 - 0.134" nominal wall thickness
 - Seamless or electric-resistance welded steel tubing or pipe
 - Steel shall be HSLAS Gr 55 per ASTM A1011 or ASTM A1008
 - Other steels may be used if they meet the following:
 - 55,000 PSI minimum yield strength
 - 70,000 PSI minimum tensile strength
 - 20% minimum elongation in 2"
 - Wall thickness (uncoated) shall be within the range of 0.122" to 0.138"
 - Outside diameter (uncoated) shall be within the range of 2.867" to 2.883"
 - Galvanization per ASTM A123 or ASTM A653 G210. For precoated steel tubing (ASTM A653), recoat tube outside diameter weld seam by metallizing with zinc wire per ASTM B833.
 - Schedule 80 Pipe (2.875" outside diameter)
 - 0.276" nominal wall thickness
 - Steel tubing per ASTM A500 Gr C
 - Other seamless or electric-resistance welded steel tubing or pipe with equivalent outside diameter and wall thickness may be used if they meet the following:
 - 46,000 PSI minimum yield strength
 - 62,000 PSI minimum tensile strength
 - 21% minimum elongation in 2"
 - Wall thickness (uncoated) shall be within the range of 0.248" to 0.304"
 - Outside diameter (uncoated) shall be within the range of 2.855" to 2.895"
 - Galvanization per ASTM A123
- See the Traffic Operations Division website for detailed drawings of sign clamps and Texas Universal Triangular Slipbase System components. The website address is: <http://www.txdot.gov/publications/traffic.htm>
- Sign supports shall not be spliced except where shown. Sign support posts shall not be spliced.

ASSEMBLY PROCEDURE

- Foundation**
- Prepare 12-inch diameter by 42-inch deep hole. If solid rock is encountered, the depth of the foundation may be reduced such that it is embedded a minimum of 18 inches into the solid rock.
 - The Engineer may permit batches of concrete less than 2 cubic yards to be mixed with a portable, motor-driven concrete mixer. For small placements less than 0.5 cubic yards, hand mixing in a suitable container may be allowed by Engineer. Concrete shall be Class A.
 - Push the pipe end of the slip base stub into the center of the concrete. Rotate the stub back and forth while pushing it down into the concrete to assure good contact between the concrete and stub. Continue to work the stub into the concrete until it is between 2 to 4 inches above the ground.
 - Plumb the stub. Allow a minimum of 4 days to set, unless otherwise directed by the Engineer.
 - The triangular slipbase system is multidirectional and is designed to release when struck from any direction.
- Support**
- Cut support so that the bottom of the sign will be 7 to 7.5 feet above the edge of the travelway (i.e., edge of the closest lane) when slip plate is below the edge of pavement or 7 to 7.5 feet above slip plate when the slip plate is above the edge of the travelway. The cut shall be plumb and straight.
 - Attach sign to support using connections shown. When multiple signs are installed on the same support, ensure the minimum clearance between each sign is maintained. See SMD(SLIP-2) for clearances based on sign types.

ADDED DETAIL A FOR CLAMP BASE
 10-2010



SIGN MOUNTING DETAILS SMALL ROADSIDE SIGNS TRIANGULAR SLIPBASE SYSTEM

SMD(SLIP-1)-08(DAL)

© TxDOT July 2002		DN: TxDOT	CK: TxDOT	DW: TxDOT	CR: TxDOT
9-08	REVISIONS	CONT	SECT	JOB	HIGHWAY
12-10 (DISTRICT)		0095	14	033, ETC	IH 20, ETC
ADDED CLAMP BASE DETAIL FOR SLIP BASE INSTALLATION		DIST	COUNTY	SHEET NO.	
		DAL	KAUFMAN, ETC	284	

DISCLAIMER: The use of this standard is governed by the "Texas Engineering Practice Act". No warranty of any kind is made by TxDOT for any purpose whatsoever. TxDOT assumes no responsibility for the conversion of this standard to other formats or for incorrect results or damages resulting from its use.

DATE: 3/1/2023 4:32:09 PM
 FILE: T:\DAL\TRAFFIC\Y_2023_PS&E\1H_20\N\Plan_Set\Standards\non-paf_standards\285_SMD(SLIP-2)-08.dgn

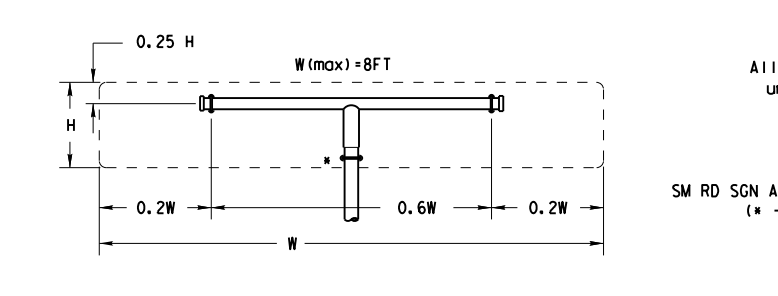
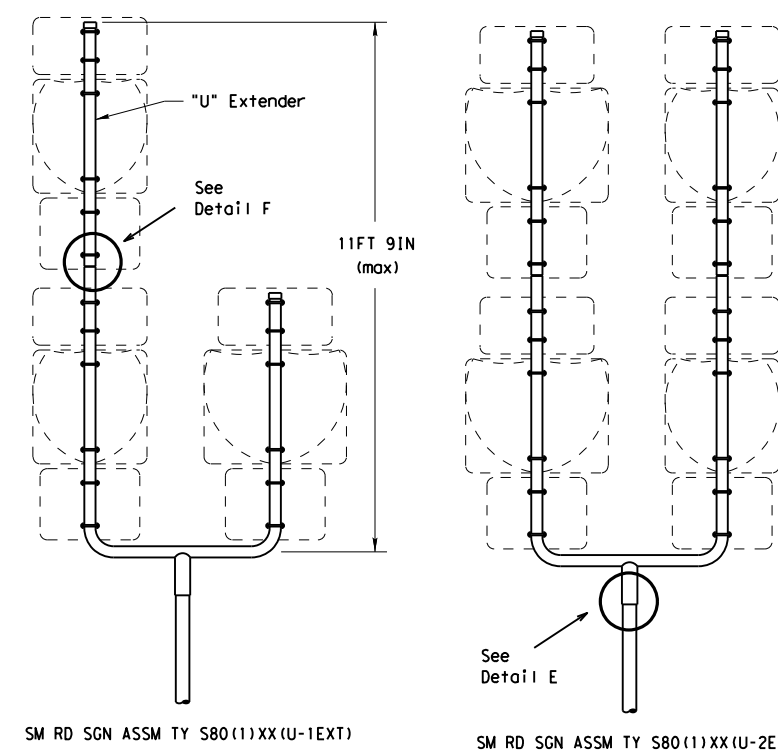
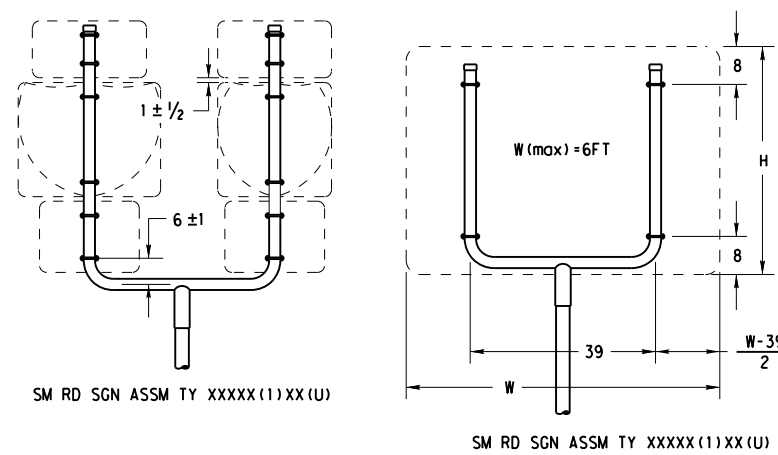
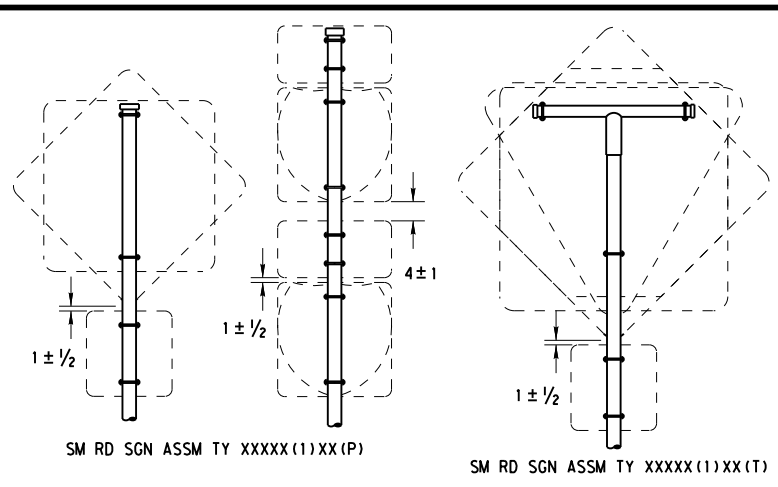

All dimensions are in english unless detailed otherwise.

SM RD SGN ASSM TY XXXX(1)XX(T) (* - See Note 12)

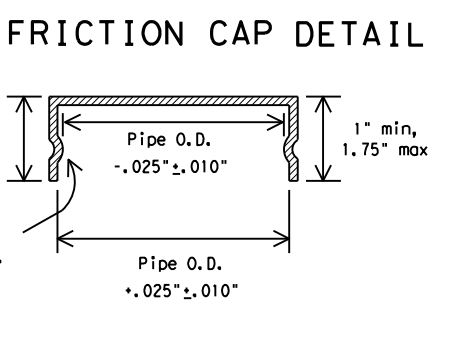
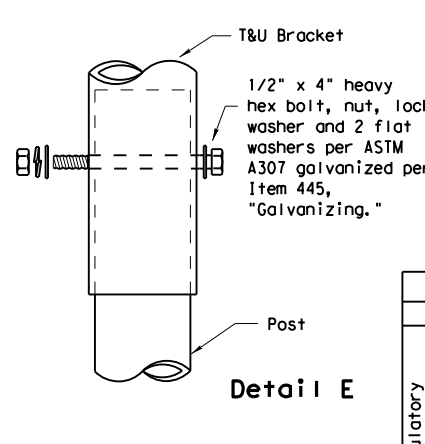
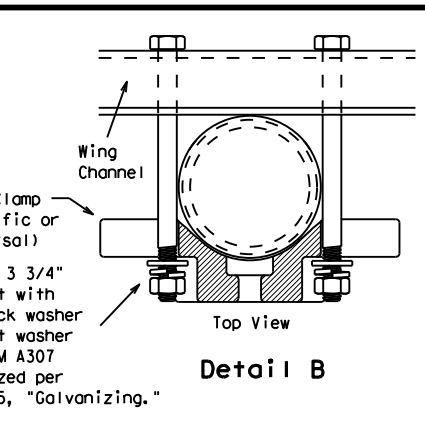
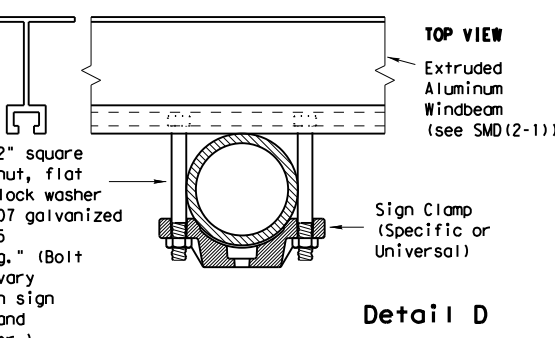
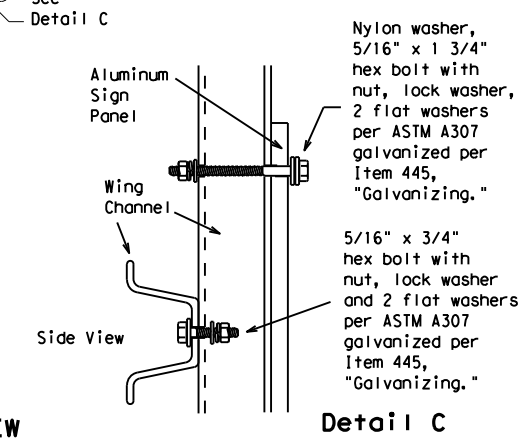
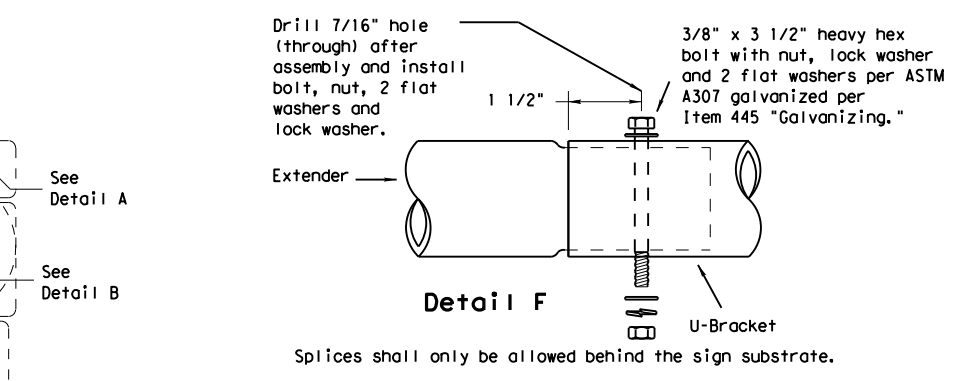
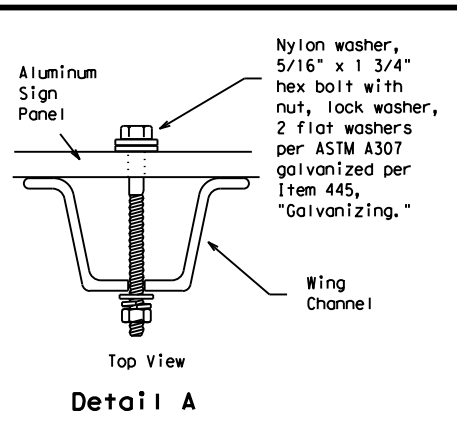
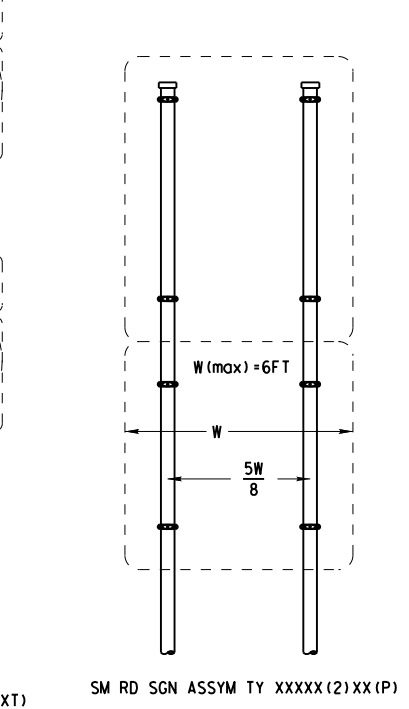
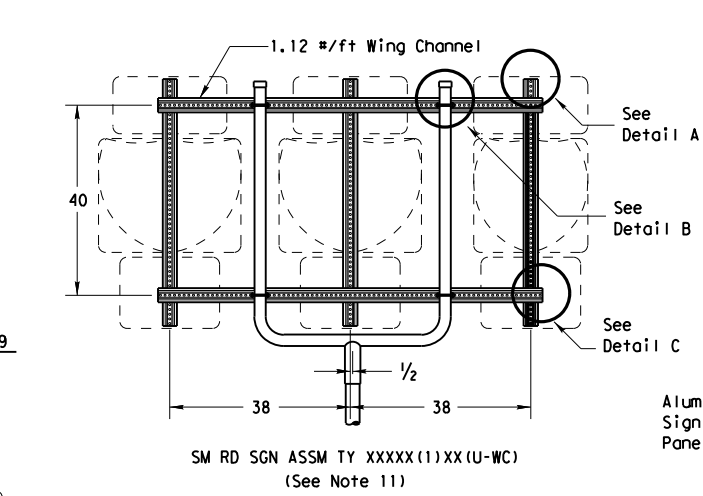
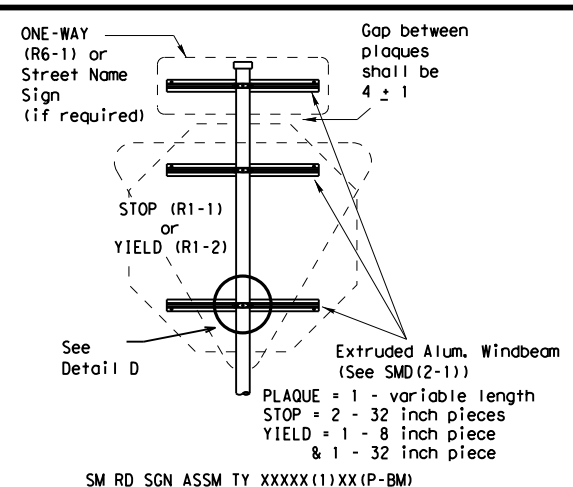

Friction caps may be manufactured from hot rolled or cold rolled steel sheets. The minimum sheet metal thickness shall be 24 gauge for all cap sizes. The rim edges shall be reasonably straight and smooth. Caps shall be sized and formed in such a manner as to produce a drive-on friction fit and have no tendency to rock when seated on the pipe. The depth shall be sufficient to give positive protection against entrance of rainwater. They shall be free of sharp creases or indentations and show no evidence of metal fracture. Caps shall have an electrodeposited coating of zinc in accordance with the requirements of ASTM B633 Class FE/ZN 8.

GENERAL NOTES:

- SIGN SUPPORT # OF POSTS MAX. SIGN AREA

10 BWG	1	16 SF
10 BWG	2	32 SF
Sch 80	1	32 SF
Sch 80	2	64 SF
- The Engineer may require that a Schedule 80 post be used in place of a 10 BWG where a sign height is abnormally high due to a fill slope.
- Sign supports shall not be spliced except where shown. Sign support posts shall not be spliced.
- Aluminum sign blanks shall conform to Departmental Material Specifications DMS-7110 and shall have the following minimum thicknesses: 0.080 for signs less than 7.5 sq. ft., 0.100 for signs 7.5 to 15 sq. ft., and 0.125 for signs greater than 15 sq. ft.
- Signs that require specific supports due to reasons in addition to windloading are indicated on the "REQUIRED SUPPORT" table on this sheet.
- For horizontal rectangular signs fabricated from flat aluminum, T-brackets are used for signs 24 inches or less in height. U-brackets are used for signs of greater height.
- When two triangular slipbase supports are used to support a single sign, they shall not be "rigidly" connected to each other except through the sign panel. This will allow each support to act independently when impacted by an errant vehicle.
- Wing channel shall meet ASTM A 1011 SS Gr 50 and be galvanized per ASTM A 123.
- Excess pipe, wing channel, or windbeam shall be cut off so that it does not extend beyond the sign panel (i.e., excess support shall not be visible when the sign is viewed from the front.) Repair galvanized coating at cut support ends per Item 445, "Galvanizing."
- Additional route markers may be added vertically, provided the total sign area does not exceed the maximum allowable amount per Note 1.
- Additional sign clamp required on the "T-bracket" post for 24 inch height signs. Place the clamp 3 inches above bottom of sign when possible.
- Post open ends shall be fitted with Friction Caps.
- Sign blanks shall be the sizes and shapes shown on the plans.

REQUIRED SUPPORT		
	SIGN DESCRIPTION	SUPPORT
Regulatory	48-inch STOP sign (R1-1)	TY 10BWG(1)XX(T) TY 10BWG(1)XX(P-BM)
	60-inch YIELD sign (R1-2)	TY 10BWG(1)XX(T) TY 10BWG(1)XX(P-BM)
	48x16-inch ONE-WAY sign (R6-1)	TY 10BWG(1)XX(T) TY 10BWG(1)XX(P-BM)
	36x48, 48x36, and 48x48-inch signs	TY 10BWG(1)XX(T)
Warning	48x60-inch signs	TY S80(1)XX(T)
	48x48-inch signs (diamond or square)	TY 10BWG(1)XX(T)
	48x60-inch signs	TY S80(1)XX(T)
	48-inch Advance School X-ing sign (S1-1)	TY 10BWG(1)XX(T)
	48-inch School X-ing sign (S2-1)	TY 10BWG(1)XX(T)
	Large Arrow sign (W1-6 & W1-7)	TY 10BWG(1)XX(T)



SIGN MOUNTING DETAILS
 SMALL ROADSIDE SIGNS
 TRIANGULAR SLIPBASE SYSTEM
 SMD(SLIP-2)-08

© TxDOT July 2002		DN: TXDOT	CK: TXDOT	DW: TXDOT	CK: TXDOT
9-08	REVISIONS	CONTRACT NO. 0095 14	SECTION 033, ETC	JOB NO. IH 20, ETC	HIGHWAY
		DIST. COUNTY		SHEET NO.	
		DAL KAUFMAN, ETC		285	

DATE: 3/1/2023 4:32:10 PM
 FILE: T:\DAL\TRAFFIC\2023 PS&E\I.H. 20\Plan Set\Standards\non-paf_standards\286_SMD(SLIP-3)-08.dgn
 DISCLAIMER: The use of this standard is governed by the "Texas Engineering Practice Act". No warranty of any kind is made by TxDOT for any purpose whatsoever. TxDOT assumes no responsibility for the conversion of this standard to other formats or for incorrect results or damages resulting from its use.

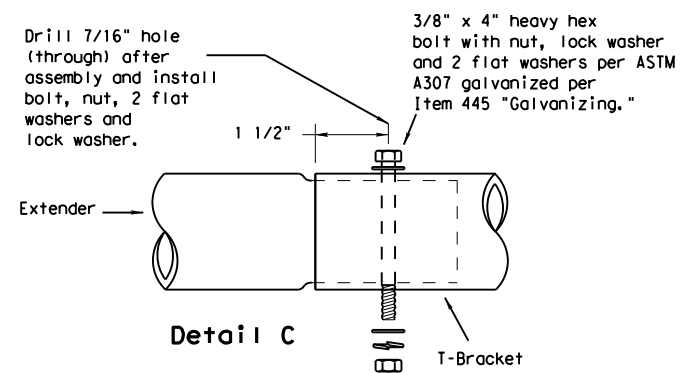
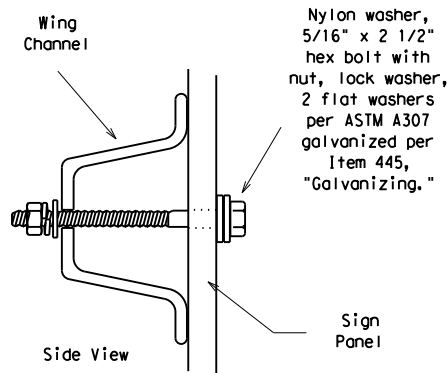
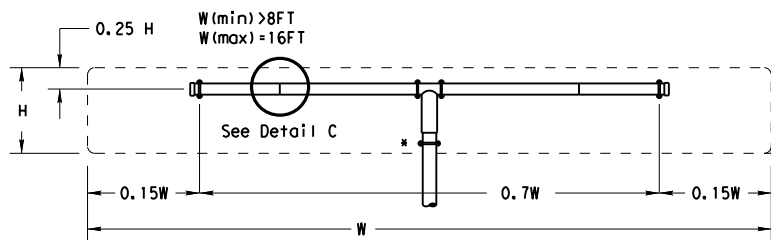

Splices shall only be allowed behind the sign substrate.

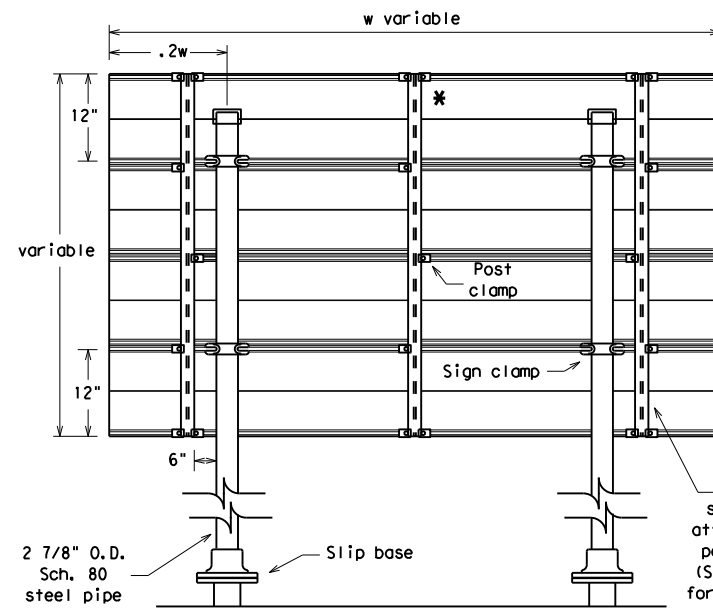
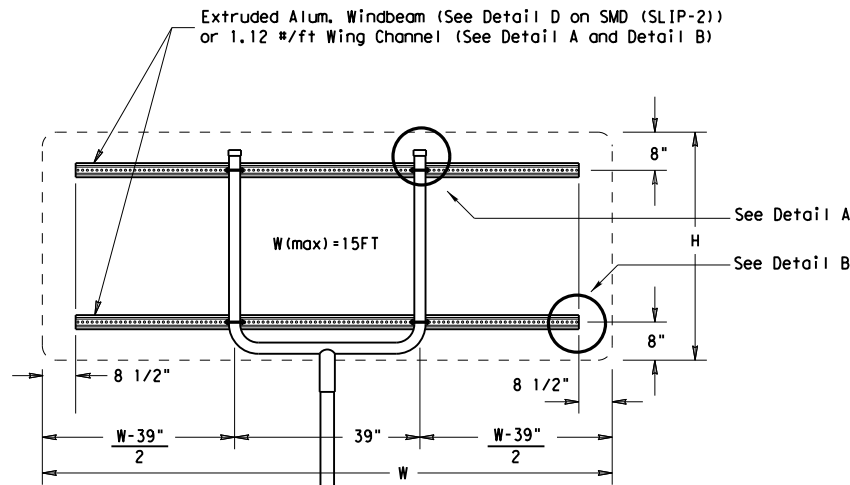

Typical Sign Mount
SM RD SGN ASSM TY S80(2)XX(IP-EXAL)
* Additional stiffener placed at approximate center of signs when sign width is greater than 10'.

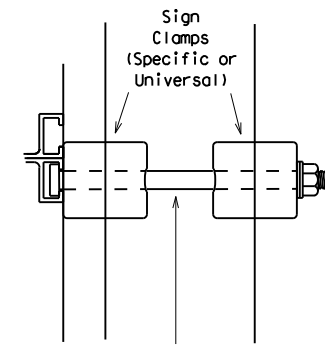

Detail E

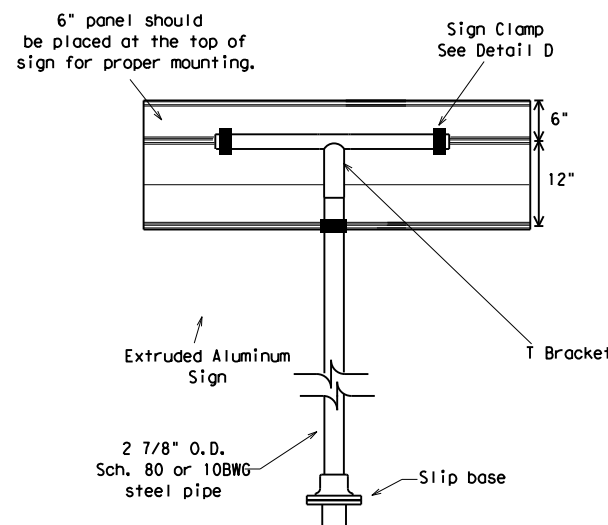
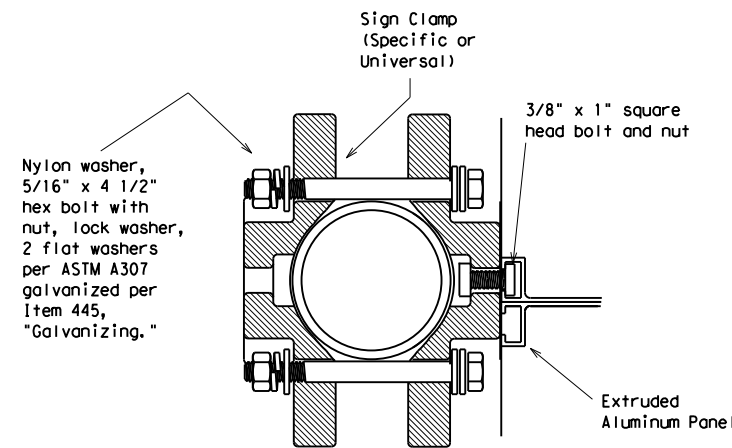
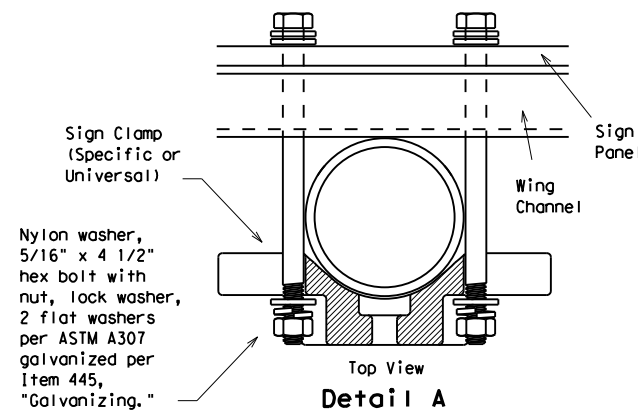

Use Extruded Alum. Windbeam as stiffeners See SMD (2-1) for additional details
See Detail E for clamp installation

GENERAL NOTES:

- | SIGN SUPPORT | # OF POSTS | MAX. SIGN AREA |
|--------------|------------|----------------|
| 10 BWG | 1 | 16 SF |
| 10 BWG | 2 | 32 SF |
| Sch 80 | 1 | 32 SF |
| Sch 80 | 2 | 64 SF |
- The Engineer may require that a Schedule 80 post be used in place of a 10 BWG where a sign height is abnormally high due to a fill slope.
- Sign supports shall not be spliced except where shown. Sign support posts shall not be spliced.
- Aluminum sign blanks shall conform to Departmental Material Specifications DMS-7110 and shall have the following minimum thicknesses: 0.080 for signs less than 7.5 sq. ft., 0.100 for signs 7.5 to 15 sq. ft., and 0.125 for signs greater than 15 sq. ft.
- Signs that require specific supports due to reasons in addition to windloading are indicated on the "REQUIRED SUPPORT" table on this sheet.
- For horizontal rectangular signs fabricated from flat aluminum, T-brackets are used for signs 24 inches or less in height. U-brackets are used for signs of greater height.
- When two triangular slipbase supports are used to support a single sign, they shall not be "rigidly" connected to each other except through the sign panel. This will allow each support to act independently when impacted by an errant vehicle.
- Wing channel shall meet ASTM A 1011 SS Gr 50 and be galvanized per ASTM A 123.
- Excess pipe, wing channel, or windbeam shall be cut off so that it does not extend beyond the sign panel (i.e., excess support shall not be visible when the sign is viewed from the front.) Repair galvanized coating at cut support ends per Item 445, "Galvanizing."
- Sign blanks shall be the sizes and shapes shown on the plans.
- Additional sign clamp required on the "T-bracket" post for 24 inch high signs. Place the clamp 3 inches above bottom of sign when possible.
- Post open ends shall be fitted with Friction Caps.

REQUIRED SUPPORT

	REQUIRED SUPPORT	
	SIGN DESCRIPTION	SUPPORT
Regulatory	48-inch STOP sign (R1-1)	TY 10BWG(1)XX(T) TY 10BWG(1)XX(P-BM)
	60-inch YIELD sign (R1-2)	TY 10BWG(1)XX(T) TY 10BWG(1)XX(P-BM)
	48x16-inch ONE-WAY sign (R6-1)	TY 10BWG(1)XX(T) TY 10BWG(1)XX(P-BM)
	36x48, 48x36, and 48x48-inch signs	TY 10BWG(1)XX(T)
	48x60-inch signs	TY S80(1)XX(T)
Warning	48x48-inch signs (diamond or square)	TY 10BWG(1)XX(T)
	48x60-inch signs	TY S80(1)XX(T)
	48-inch Advance School X-ing sign (S1-1)	TY 10BWG(1)XX(T)
	48-inch School X-ing sign (S2-1)	TY 10BWG(1)XX(T)
	Large Arrow sign (W1-6 & W1-7)	TY 10BWG(1)XX(T)



**SIGN MOUNTING DETAILS
SMALL ROADSIDE SIGNS
TRIANGULAR SLIPBASE SYSTEM
SMD(SLIP-3)-08**

© TxDOT July 2002		DN: TxDOT	CK: TxDOT	DW: TxDOT	CK: TxDOT
9-08	REVISIONS	CONT	SECT	JOB	HIGHWAY
		0095	14	033, ETC	IH 20, ETC
		DIST	COUNTY	SHEET NO.	
		DAL	KAUFMAN, ETC	286	

DISCLAIMER: The use of this standard is governed by the "Texas Engineering Practice Act". No warranty of any kind is made by TxDOT for any purpose whatsoever. TxDOT assumes no responsibility for the conversion of this standard to other formats or for incorrect results or damages resulting from its use.

DATE: 3/1/2023 4:32:10 PM
 FILE: T:\DAL\TRAFFIC\2023 PS&E\I.H. 20\Plan_Set\Standards\non-paf_standards\287_SMD(2-1)-08.dgn

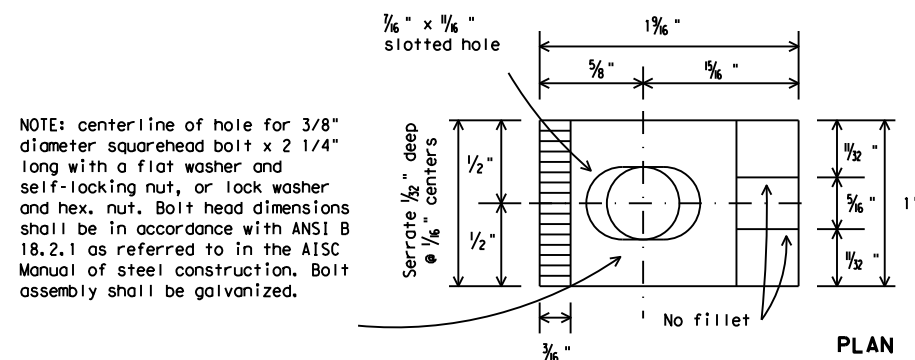

NOTE: centerline of hole for 3/8" diameter squarehead bolt x 2 1/4" long with a flat washer and self-locking nut, or lock washer and hex. nut. Bolt head dimensions shall be in accordance with ANSI B 18.2.1 as referred to in the AISC Manual of steel construction. Bolt assembly shall be galvanized.

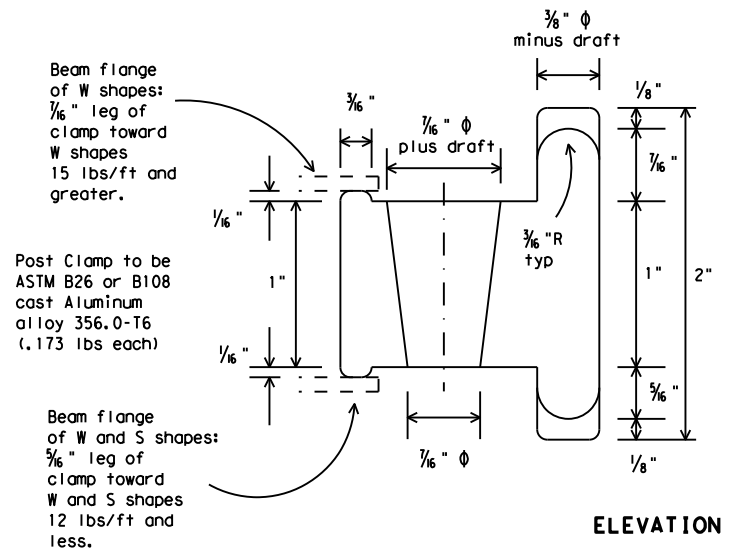
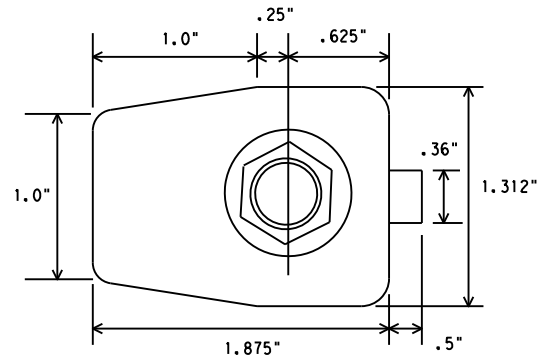

Beam flange of W shapes: 1/16" leg of clamp toward W shapes 15 lbs/ft and greater.
 Post Clamp to be ASTM B26 or B108 cast Aluminum alloy 356.0-T6 (.173 lbs each)
 Beam flange of W and S shapes: 3/16" leg of clamp toward W and S shapes 12 lbs/ft and less.

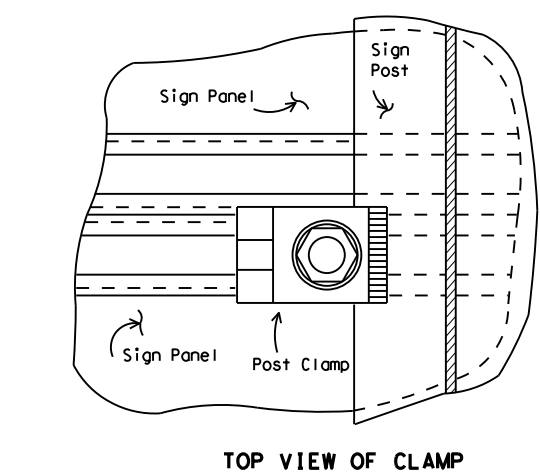
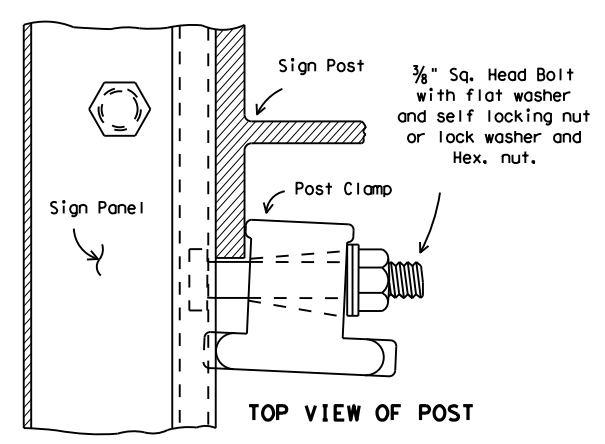
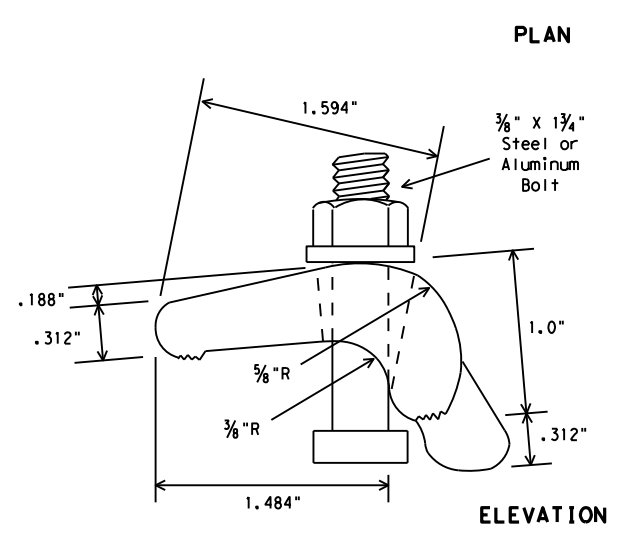

DEPARTMENTAL MATERIAL SPECIFICATIONS	
SIGN HARDWARE	DMS-7120

- GENERAL NOTES:
- Design conforms with AASHTO Specifications for the design and construction of structural supports for highway signs.
 - Materials and fabrication shall conform to the requirements of the Department material specifications.
 - Structural steel shall be "low-alloy steel" for non-bridge structures per Item 442, "Metal For Structures."
 - For fiberglass substrate connection details, see manufacturer's recommendations.

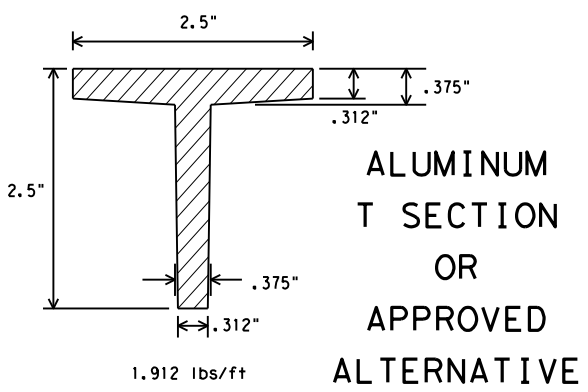

WINDBEAM CROSS SECTION
 Windbeam to be extruded aluminum (1.175 lbs/ft) or approved alternative

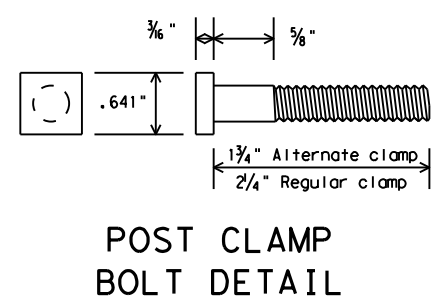
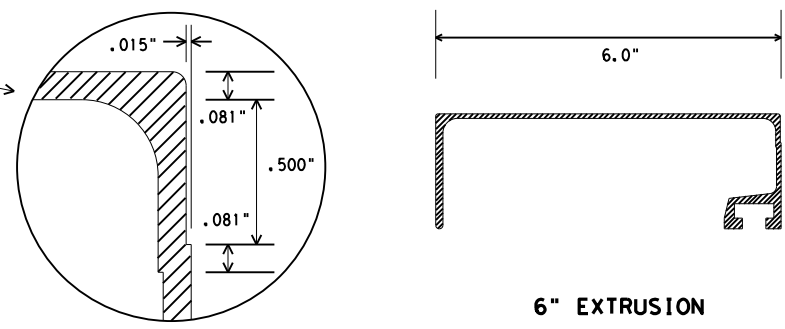
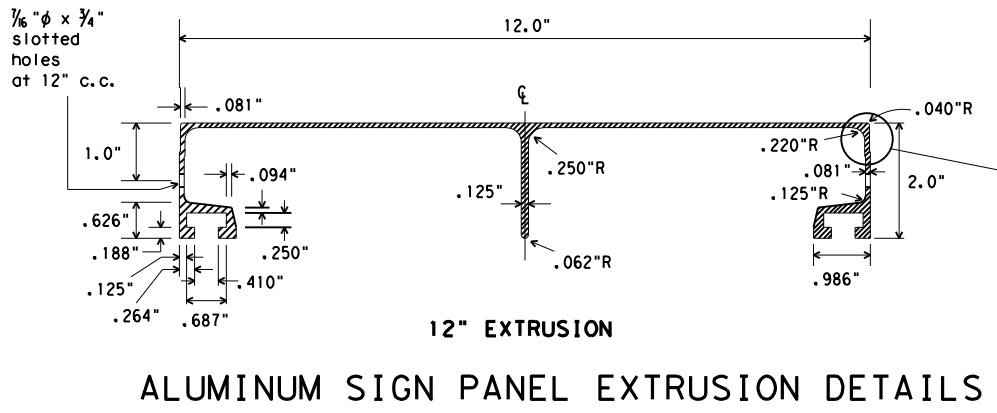
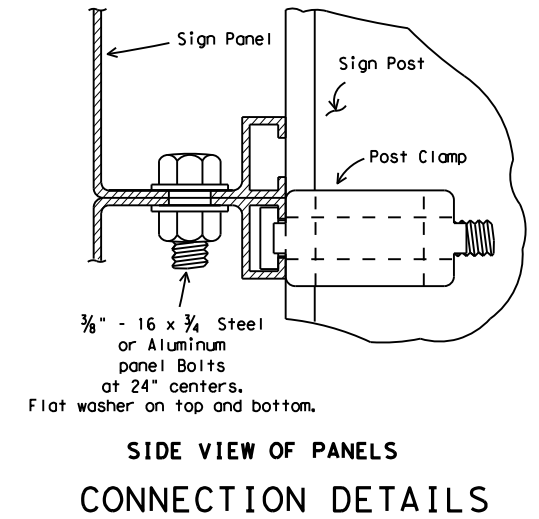
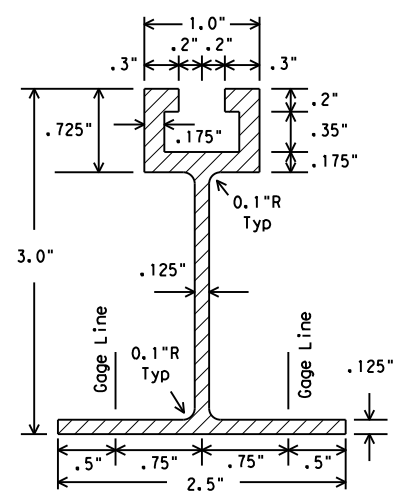

Texas Department of Transportation
 Traffic Operations Division

**SIGN MOUNTING DETAILS-
 EXTRUDED ALUMINUM
 SIGN PANELS & HARDWARE**
 SMD(2-1)-08

© TxDOT 2001	DN: TxDOT	CK: TxDOT	DW: TxDOT	CK: TxDOT	
9-08	REVISIONS	CONT	SECT	JOB	HIGHWAY
		0095	14	033, ETC	IH 20, ETC
		DIST	COUNTY	SHEET NO.	
		DAL	KAUFMAN, ETC	287	

DISCLAIMER: The use of this standard is governed by the "Texas Engineering Practice Act". No warranty of any kind is made by TxDOT for any purpose whatsoever. TxDOT assumes no responsibility for the conversion of this standard to other formats or for incorrect results or damages resulting from its use.
 DATE: 3/1/2023 4:32:11 PM
 FILE: I:\DAL\TRAFFIC\2023 PS&E\I.H. 20\N\Plan Set\Standards\non-paf standard-ds\288_SMD(2-2)-08.dgn

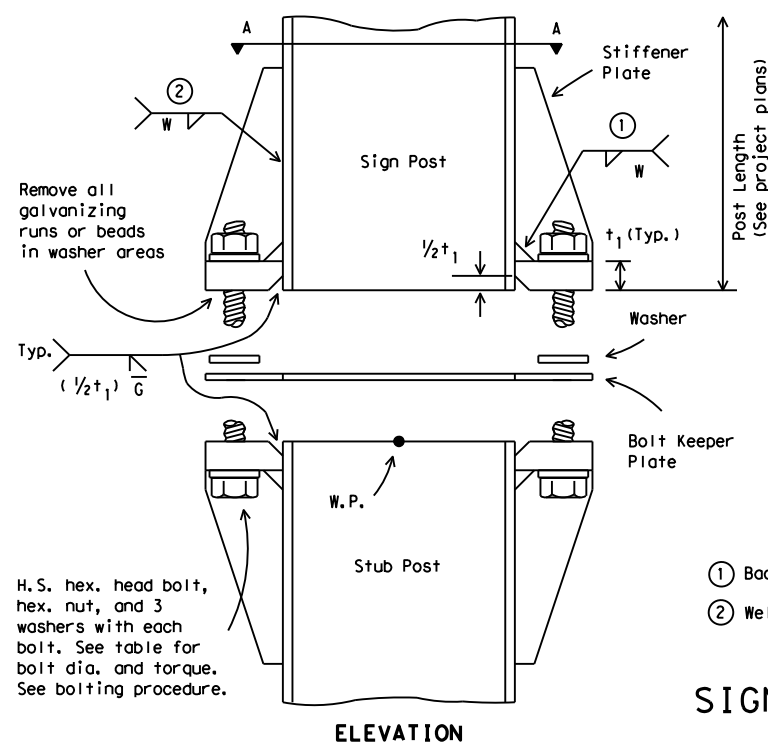

ELEVATION

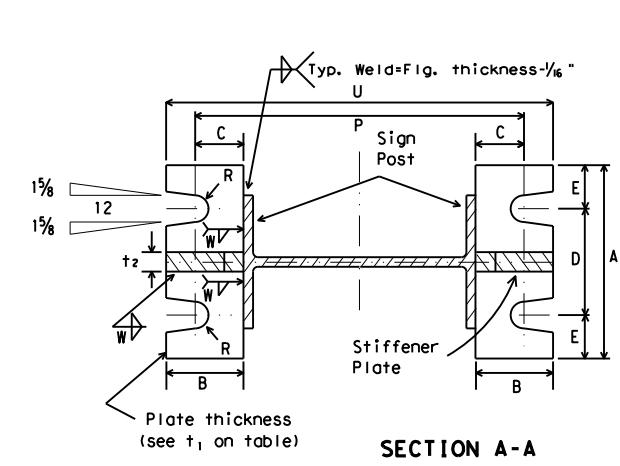

- ① Back up weld to be made before installing stiffener plate
- ② Weld W may be continued across clips to seal joint

SIGN POST AND STUB POST
(For W Shapes)

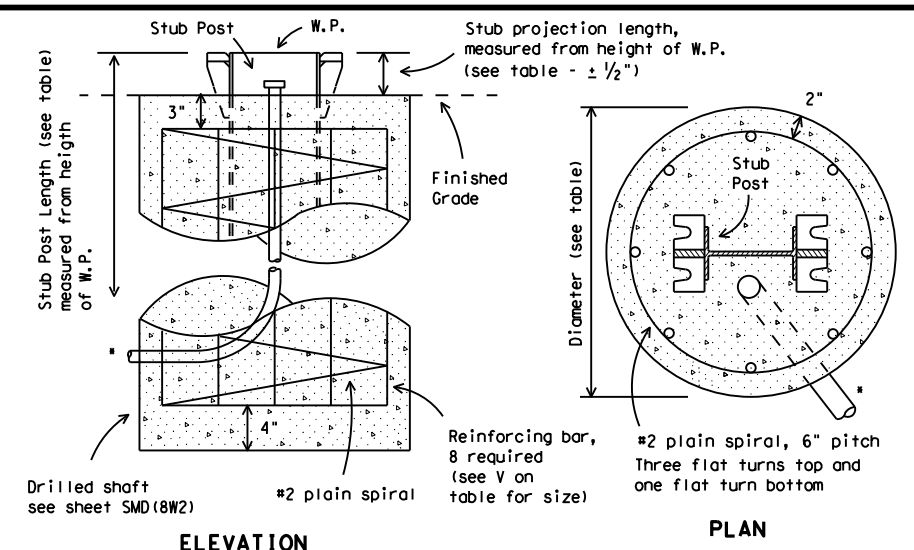
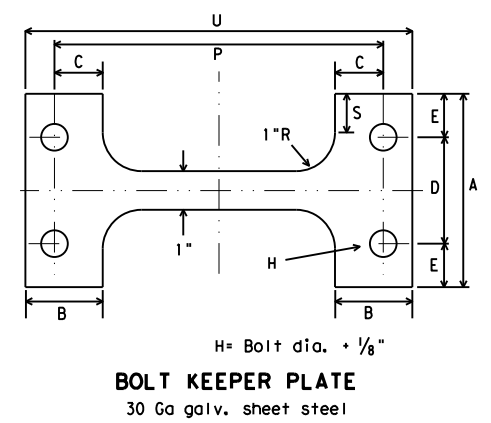
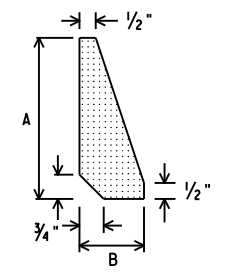

*Note: For signs with electrical apparatus, see ED(10) for conduit required in foundation.

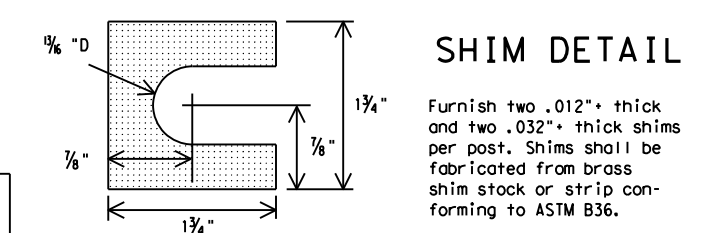

- BOLTING PROCEDURE FOR ASSEMBLY OF BASE CONNECTION:**
1. Assemble sign post, BOLT KEEPER PLATE and stub post with bolts and three flat washers per bolt as shown.
 2. Shim as required to plumb post.
 3. Tighten all bolts the maximum possible with a 12 to 15 inch wrench to clean bolt threads and to bed washers and shims.
 4. Loosen each bolt in sequence and retighten bolts in a systematic order to the prescribed torque. Do not over-tighten.
 5. To prevent nut loosening, burr threads of bolt at junction with nut using a center punch.

Dimensions Post Size	Base Connection Data Table											Perforated Fuse Plate Data Table						Bolt Keeper Data			Foundation Data							
	Bolt Size & Torque	A	B	C	D	E	t_1	t_2	W	R	F	G	J	K	M	d_1	d_2	t_3	Bolt Dia.	Wt. (ea.) (lbs.)	Bolt length	P	S	U	Stub length	Stub projection	Dr. Shaft diameter	Bar V Size
W6x9	$\frac{5}{8}$ " ϕ x $2\frac{3}{4}$ "										$\frac{4}{4}$ "	2"	4"	$2\frac{1}{4}$ "	1"	$\frac{9}{16}$ "	$\frac{3}{4}$ "	$\frac{1}{4}$ "	$\frac{1}{2}$ "	1.01	$1\frac{1}{2}$ "	$8\frac{3}{8}$ "		$9\frac{7}{8}$ "	2'-0"	3"		#5
W6x12	440-450 inch pounds	5"	2"	$1\frac{1}{4}$ "	$2\frac{3}{4}$ "	$1\frac{1}{8}$ "	$\frac{3}{4}$ "	$\frac{1}{2}$ "	$1\frac{1}{4}$ "	$\frac{1}{32}$ "	5"	$2\frac{1}{2}$ "	6"	$3\frac{1}{2}$ "	$1\frac{1}{2}$ "	$\frac{11}{16}$ "	$1\frac{1}{4}$ "	$\frac{3}{8}$ "	$\frac{5}{8}$ "	2.51	$2\frac{1}{4}$ "	$8\frac{1}{2}$ "	1"	10"	2'-0"	3"		#5
W6x15	36-38 foot pounds										5"	$2\frac{1}{2}$ "	$5\frac{1}{4}$ "	$2\frac{3}{4}$ "	$1\frac{1}{4}$ "	$\frac{11}{16}$ "	$1\frac{1}{16}$ "	$\frac{3}{8}$ "	$\frac{5}{8}$ "	2.26	$2\frac{1}{4}$ "	$10\frac{5}{8}$ "		10"	2'-6"	3"		#6
W8x18											5"	$2\frac{1}{2}$ "	$5\frac{1}{4}$ "	$2\frac{3}{4}$ "	$1\frac{1}{4}$ "	$\frac{13}{16}$ "	1"	$\frac{1}{2}$ "	$\frac{3}{4}$ "	3.35	$2\frac{1}{4}$ "	11"		$12\frac{7}{8}$ "	3'-0"	$2\frac{1}{2}$ "		#7
W8x21	$\frac{3}{4}$ " ϕ x $3\frac{1}{2}$ "										$5\frac{1}{2}$ "	$2\frac{1}{2}$ "	$5\frac{1}{4}$ "	$2\frac{3}{4}$ "	$1\frac{1}{4}$ "	$\frac{13}{16}$ "	1"	$\frac{1}{2}$ "	$\frac{3}{4}$ "	3.35	$2\frac{1}{4}$ "	11"		$12\frac{3}{4}$ "	3'-0"	$2\frac{1}{2}$ "		#8
W10x22	740-750 inch pounds	6"	$2\frac{1}{4}$ "	$1\frac{3}{8}$ "	$3\frac{1}{2}$ "	$1\frac{1}{4}$ "	1"	$\frac{3}{4}$ "	$\frac{5}{16}$ "	$\frac{13}{32}$ "	6"	3"	$5\frac{3}{4}$ "	$2\frac{3}{4}$ "	$1\frac{3}{8}$ "	$\frac{13}{16}$ "	$1\frac{1}{8}$ "	$\frac{1}{2}$ "	$\frac{3}{4}$ "	4.03	$2\frac{1}{4}$ "	$12\frac{7}{8}$ "	$1\frac{1}{2}$ "	$14\frac{5}{8}$ "	3'-0"	$2\frac{1}{2}$ "		#9
W10x26	62-63 foot pounds										6"	3"	$6\frac{1}{2}$ "	$3\frac{1}{2}$ "	$1\frac{5}{8}$ "	$\frac{13}{16}$ "	$1\frac{5}{16}$ "	$\frac{1}{2}$ "	$\frac{3}{4}$ "	4.47	$2\frac{1}{4}$ "	$13\frac{3}{8}$ "	$1\frac{1}{2}$ "	$14\frac{7}{8}$ "	3'-0"	$2\frac{1}{2}$ "		#10
W12x26											6"	3"	$6\frac{1}{2}$ "	$3\frac{1}{2}$ "	$1\frac{5}{8}$ "	$\frac{13}{16}$ "	$1\frac{5}{16}$ "	$\frac{1}{2}$ "	$\frac{3}{4}$ "	4.47	$2\frac{1}{4}$ "	15"		$16\frac{3}{4}$ "	3'-0"	$2\frac{1}{2}$ "		#11
S3x5.7	$\frac{1}{2}$ " ϕ x $2\frac{1}{2}$ "	See Detail Below									$3\frac{3}{4}$ "	$1\frac{1}{2}$ "	$2\frac{5}{8}$ "	$1\frac{1}{2}$ "	$\frac{5}{8}$ "	$\frac{9}{16}$ "	$\frac{3}{8}$ "	$\frac{1}{4}$ "	$\frac{1}{2}$ "	0.60	$1\frac{1}{2}$ "						Non-reinforced	
S4x7.7	440-450 inch pounds 36-38 foot pounds	See Detail Below									$3\frac{3}{4}$ "	$1\frac{1}{2}$ "	$2\frac{5}{8}$ "	$1\frac{1}{2}$ "	$\frac{5}{8}$ "	$\frac{9}{16}$ "	$\frac{3}{8}$ "	$\frac{1}{4}$ "	$\frac{1}{2}$ "	0.60	$1\frac{1}{2}$ "						Non-reinforced	

③ Foundation design shall be Type G Mount, see SMD (TY G).

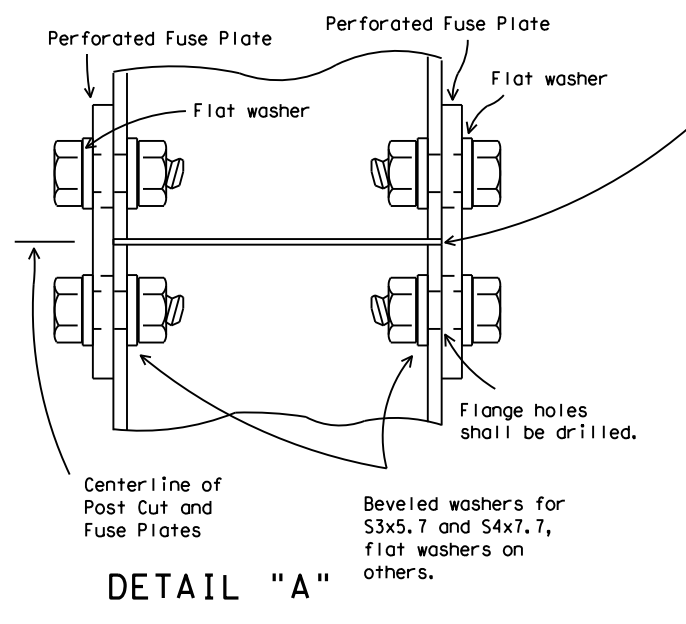
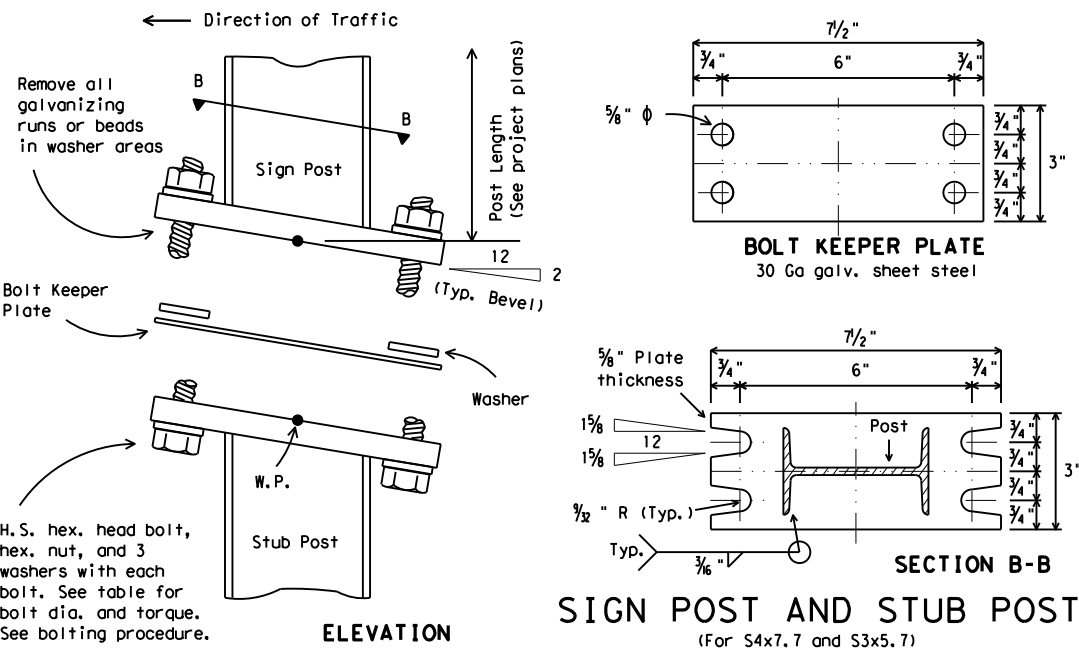

PERFORATED FUSE PLATE DETAIL

Use H.S. hex head bolts, hex head nut and bevel or flat washer (where req'd) under nut. All holes shall be drilled, sub-punched and reamed. All plate cuts shall preferably be saw cuts. However, flame cutting will be permitted provided all edges are ground. Metal projecting beyond the plane of the plate face will not be permitted. Steel fuse plates shall conform to the requirements of ASTM A36. ASTM A572 Grade 50 or ASTM A588 may be substituted for A36 at the option of the fabricator. Mill test reports shall be submitted for Fuse Plates. Steel used shall have an ultimate tensile strength not to exceed 80 KSI. For alternative Fuse Plate contact Traffic Operations Division.

Texas Department of Transportation
 Traffic Operations Division

**SIGN MOUNTING DETAILS-
LARGE ROADSIDE SIGNS
FOUNDATION & STUB**

SMD(2-2)-08

© TxDOT August 1995		DN: TxDOT	CK: TxDOT	DW: TxDOT	CK: TxDOT
4-98	REVISIONS	CONT	SECT	JOB	HIGHWAY
9-08		0095	14	033, ETC	1H 20, ETC
		DIST	COUNTY		SHEET NO.
		DAL	KAUFMAN, ETC		288

DISCLAIMER: The use of this standard is governed by the "Texas Engineering Practice Act". No warranty of any kind is made by TxDOT for any purpose whatsoever. TxDOT assumes no responsibility for the conversion of this standard to other formats or for incorrect results or damages resulting from its use.

DATE: 3/1/2023 4:32:12 PM
 FILE: I:\DAL\TRAFFIC\2023 PS&E\I.H. 20\Plan_Set\Standards\non-paf_standards\289_SMD(2-3)-08.dgn

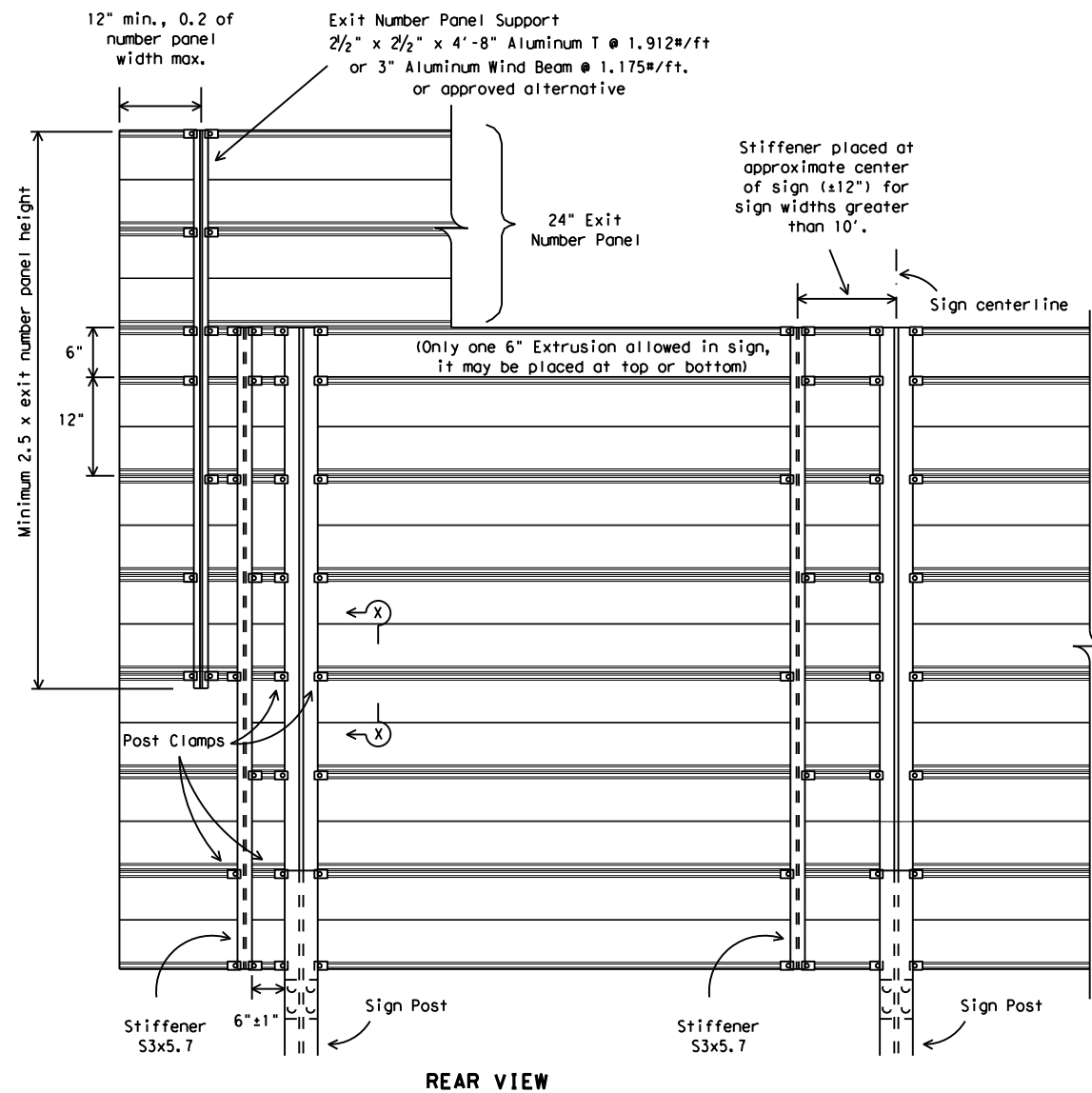

REAR VIEW

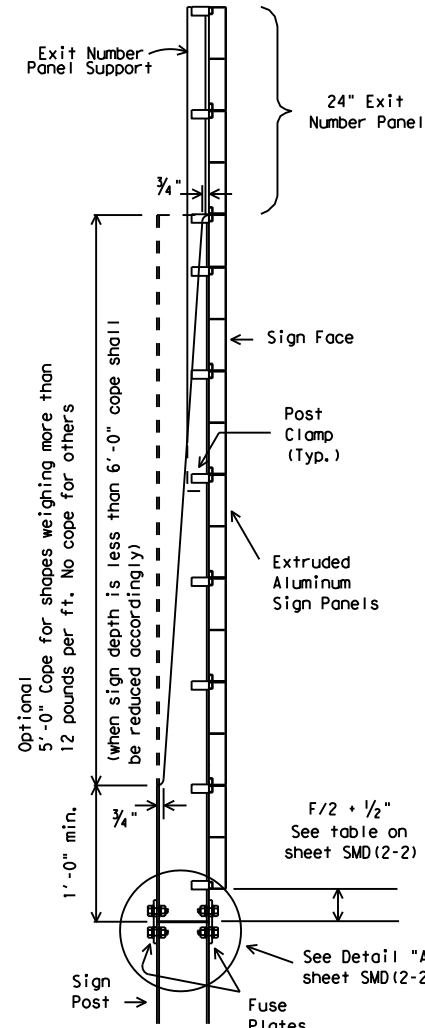

SIDE VIEW

ALUMINUM PARENT SIGN & EXIT NUMBER PANEL MOUNTING DETAILS

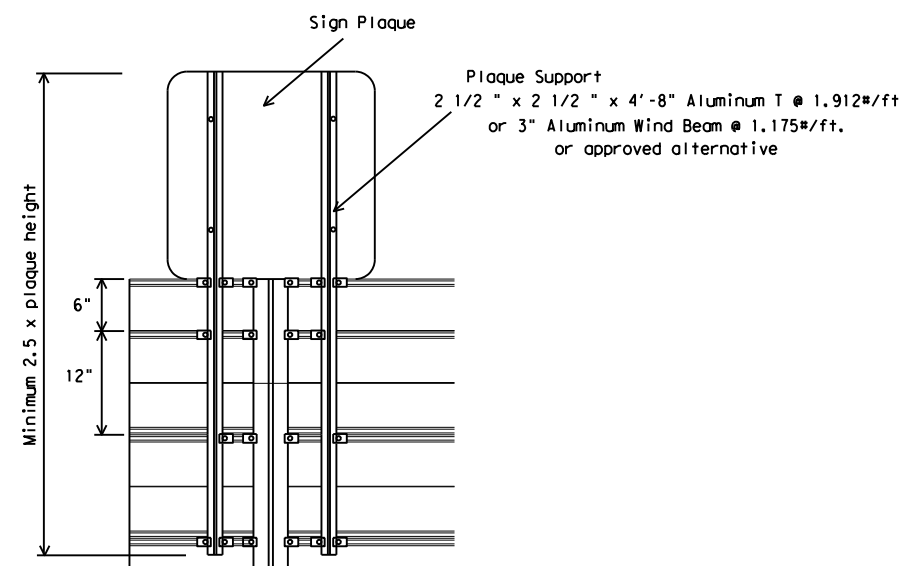

SIGN PLAQUE MOUNTING DETAIL TO ALUMINUM PARENT SIGN

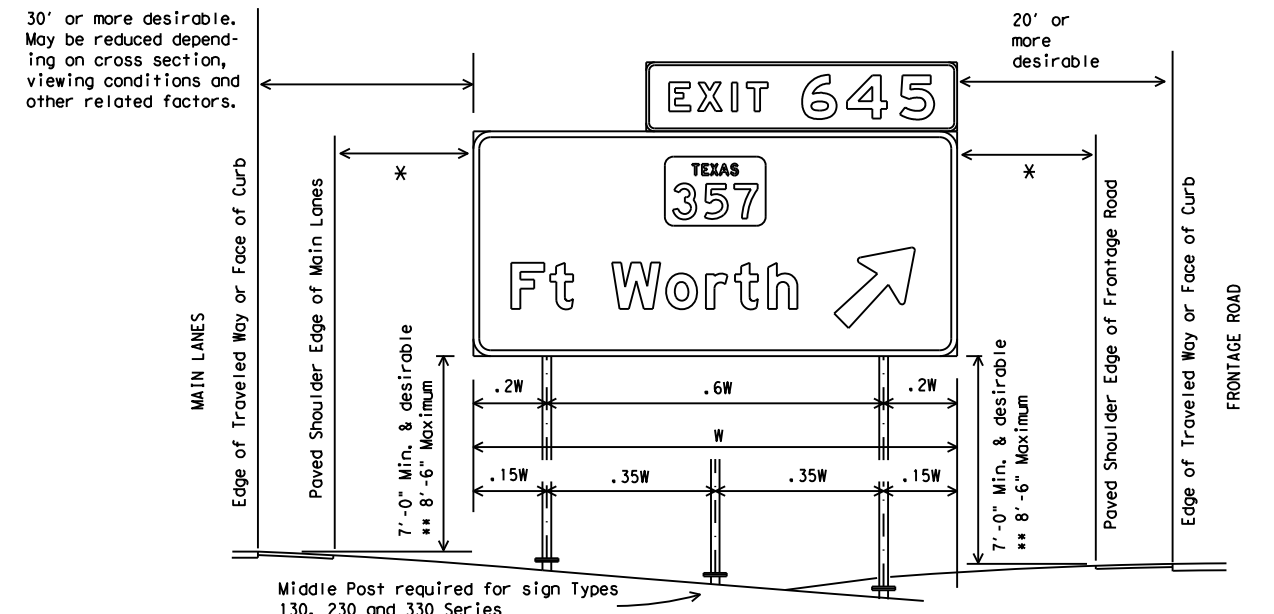

TYPICAL SIGN INSTALLATION AND LOCATION

LATERAL CLEARANCE NOTES:

Lateral clearances of signs mounted on median side of main lanes are the same as shown above where space will permit.

Where a sign is to be located behind guardrail, an allowable minimum clearance of five feet may be used, measured from the face of the guardrail to the near edge of sign.

* - 6' minimum and desirable may be used only in areas of limited lateral clearance and when approved by the Engineer.

POST SPACING NOTES:

Post spacing on a two post sign may vary a maximum of plus or minus 10% of total sign width to fit field conditions.

Post spacing on a three post sign may vary a maximum of plus or minus 5% of total sign width to fit field conditions.

SIGN HEIGHT NOTES:

** The 8' 6" maximum may be exceeded when placing signs on extreme slopes. In these conditions, a 7' minimum from natural ground to bottom of sign must be maintained.

DEPARTMENTAL MATERIAL SPECIFICATIONS	
ALUMINUM SIGN BLANKS	DMS-7110
SIGN HARDWARE	DMS-7120

GENERAL NOTES:

- Exit number panel shall be mounted to the right hand side of the parent sign for right exits and to the left hand side for left exits. The number panel shall be mounted with two uprights so its right edge is even with the right edge of the parent sign or vice-versa for left hand exits.
- Exit number panel support shall be symmetrical about number panel centerline.
- Exit number panel support shall be ASTM A36 structural steel galvanized after fabrication, or ASTM B221 aluminum alloy 6061-T6 or approved alternative.
- All bolts, nuts and washers shall be galvanized per ASTM Designation: B695 Class 50, or A153 Class C or D.
- Posts, parent sign panels, and exit number panels shall comply with notes on sheets SMD(2-1) and SMD(2-2).
- Signs (such as exit number panels) attached above a parent sign shall be made of the same type material as the parent sign. General Service and Routing signs may be fabricated from flat sheet aluminum.
- Exit number panel support and other connection hardware required to fasten exit number panel to parent sign shall be subsidiary to "Aluminum Signs" or "Fiberglass Signs."
- For fiberglass sign installation details, see manufacturer's recommendations.



SIGN MOUNTING DETAILS-
LARGE ROADSIDE SIGNS

SMD(2-3)-08

© TxDOT August 1995	DN: TxDOT	CK: TxDOT	DW: TxDOT	CK: TxDOT	
9-08	REVISIONS	CONT	SECT	JOB	HIGHWAY
		0095	14	033, ETC	IH 20, ETC
		DIST	COUNTY	SHEET NO.	
		DAL	KAUFMAN, ETC	289	

DISCLAIMER: The use of this standard is governed by the "Texas Engineering Practice Act". No warranty of any kind is made by TxDOT for any purpose whatsoever. TxDOT assumes no responsibility for the conversion of this standard to other formats or for incorrect results or damages resulting from its use.

DATE: 3/1/2023 4:32:12 PM
 FILE: I:\DAL\TRAFFIC\2023 PS&E\I\H 20\Plan_Set\Standards\non-paf_standards\290_SMD(2-4)-08.dgn

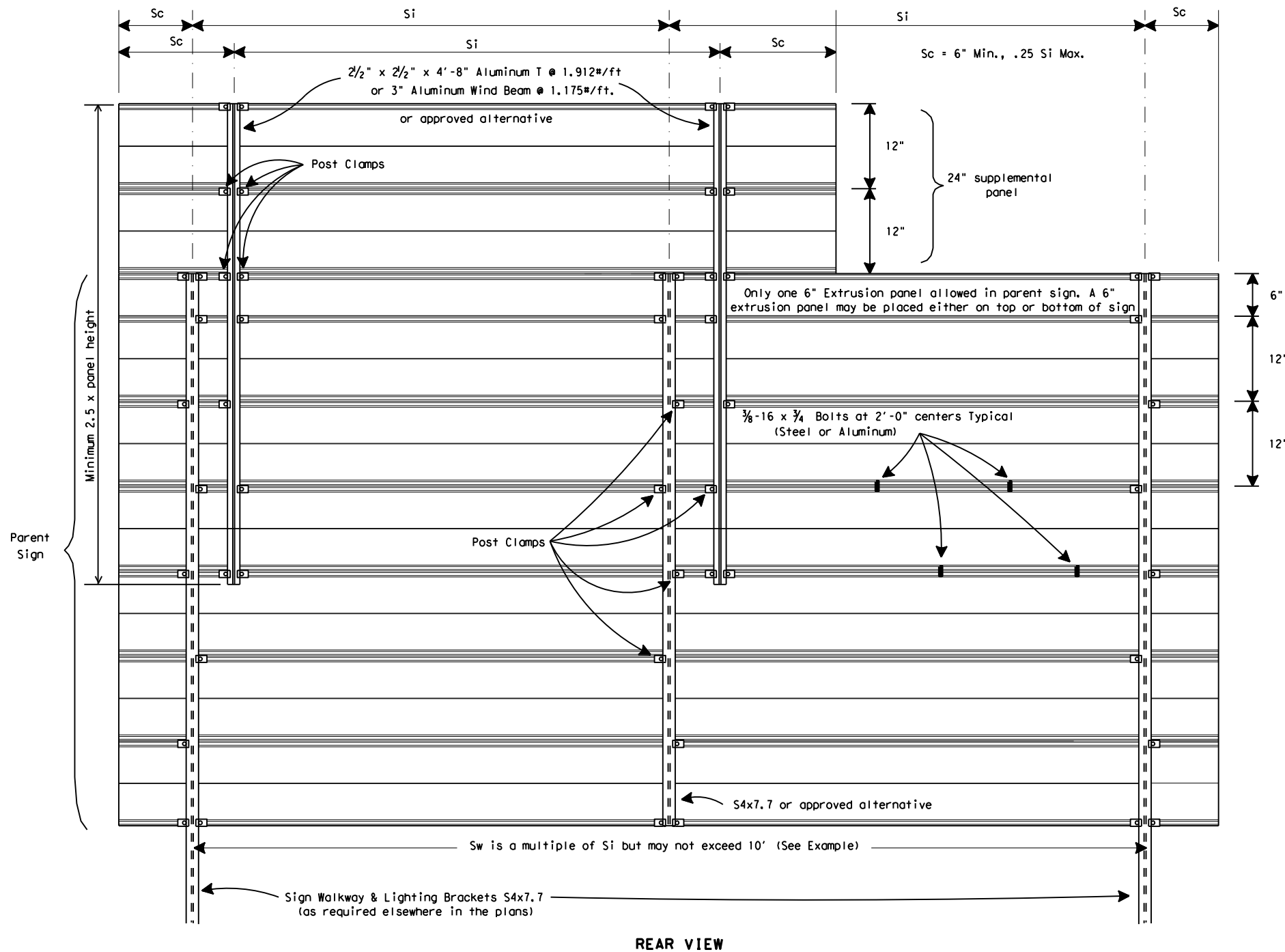

EXAMPLES (FOR DETERMINING Si and Sw)

NO.	ZONE	"d"	EXIT PANEL	WALKWAY	Si	Sw	COMMENT
1	1	15.0	YES	YES	4.5	9.0	Sw=2x(Si)
2	2	14.0	YES	NO	7.5	7.5	Sw = Si
3	1	15.0	NO	NO	8.5	8.5	Sw = Si
4	3	14.0	NO	YES	10.0	10.0	Sw = Si

Values shown for Si are maximum values. Si may be varied for different sign lengths and Truss mounting conditions. Sw should not exceed two times Si (Max.) or 10 feet.

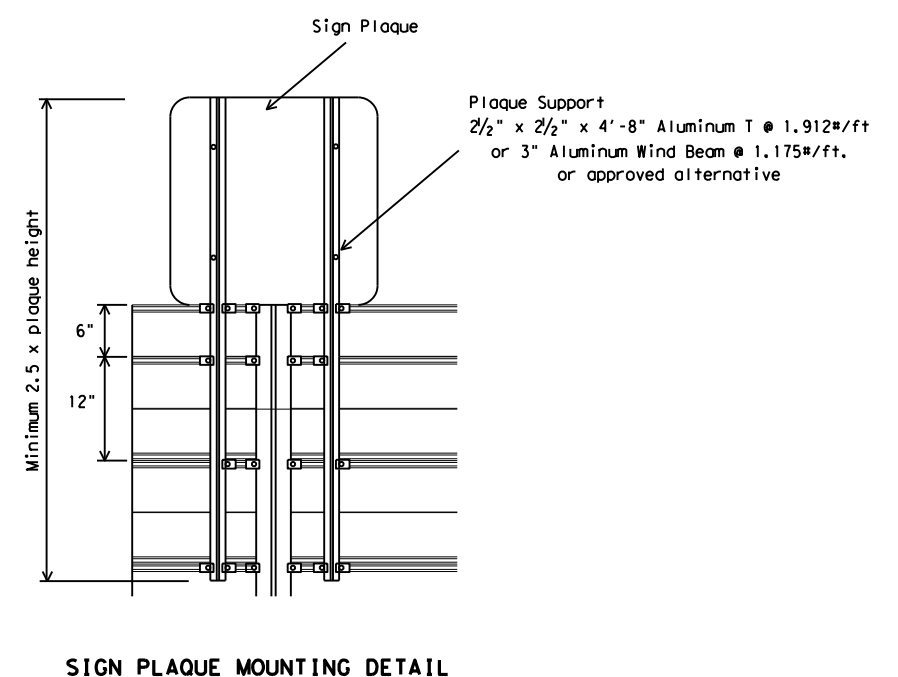

"d" Deepest Sign in Group (Ft.)	MAXIMUM SIGN SUPPORT SPACING "Si" (FEET)																			
	EXTRUDED ALUMINUM SIGN PANELS																			
	WITH EXIT NUMBER PANELS								WITHOUT EXIT NUMBER PANELS											
	WITH WALKWAYS				WITHOUT WALKWAYS				WITH WALKWAYS				WITHOUT WALKWAYS							
WIND ZONE	WIND ZONE	WIND ZONE	WIND ZONE	WIND ZONE	WIND ZONE	WIND ZONE	WIND ZONE	WIND ZONE	WIND ZONE	WIND ZONE	WIND ZONE	WIND ZONE	WIND ZONE	WIND ZONE	WIND ZONE	WIND ZONE				
1	2	3	4	1	2	3	4	1	2	3	4	1	2	3	4	1	2	3	4	
15	4.5	7	8	10	5	7	8	10	7	8	9	10	8.5	10	10	10	10	10	10	10
14	6	7.5	9.5	10	6	7.5	9.5	10	8	9	10	10	10	10	10	10	10	10	10	10
13	7.5	9	10	10	7.5	9	10	10	9	10	10	10	10	10	10	10	10	10	10	10
12	8.5	10	10	10	8.5	10	10	10	10	10	10	10	10	10	10	10	10	10	10	10
11 or less	10	10	10	10	10	10	10	10	10	10	10	10	10	10	10	10	10	10	10	10

For fiberglass sign installations, see manufacturer's recommendations.

Texas Department of Transportation
 Traffic Operations Division

**SIGN MOUNTING DETAILS-
 OVERHEAD SIGNS
 EXTRUDED ALUMINUM
 SMD(2-4)-08**

© TxDOT December 1995		DN: TxDOT	CK: TxDOT	DW: TxDOT	CK: TxDOT
9-08	REVISIONS	CONT	SECT	JOB	HIGHWAY
		0095	14	033, ETC	IH 20, ETC
		DIST	COUNTY	SHEET NO.	
		DAL	KAUFMAN, ETC	290	

DATE: 3/2/2023 1:55:50 PM
 FILE: T:\DAL\TRAFFAFY_2023 PS&E\IH 20\Plan Set\Standard.s\non-pdf standard.s\291_SMD(2-6)-01.dgn
 DISCLAIMER: The use of this standard is governed by the "Texas Engineering Practice Act". No warranty of any kind is made by TxDOT for any purpose whatsoever. TxDOT assumes no responsibility for the conversion of this standard to other formats or for incorrect results or damages resulting from its use.

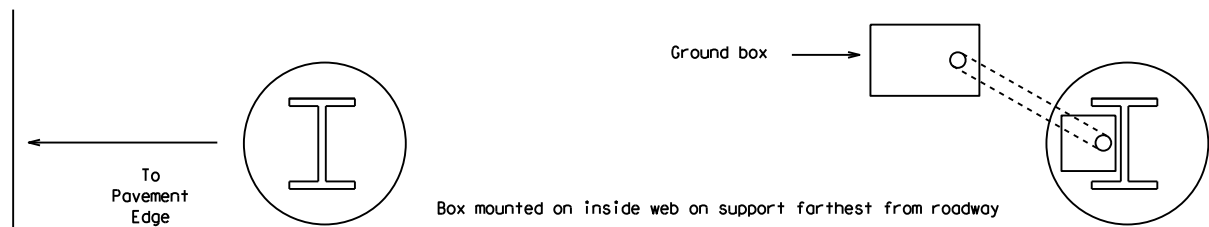

Box mounted on inside web on support farthest from roadway

PLAN VIEW

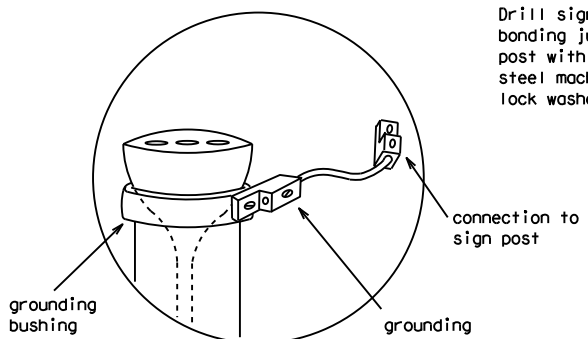

DETAIL C

⚠ Pull connector down tight against conduit then clamp in ground box. See Detail "D"

Drill sign post - structure leg, terminate bonding jumper with listed connector to post with a 10-24 (3/16") min. stainless steel machine screw, nut, flat washer and lock washer made wrench tight.

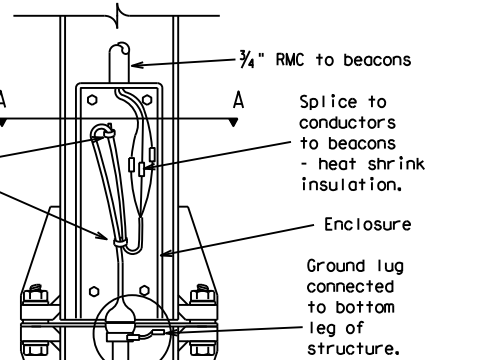

ELECTRICAL CONNECTION DETAIL

Enclosure cover not shown for clarity
 Detail shows channel greater than 4 inches.
 Less than 4 inches similar, see Detail A.

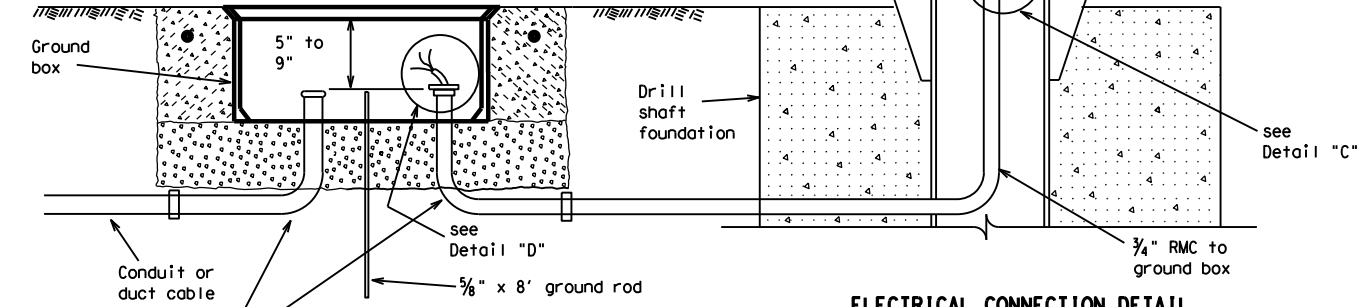

Use RMC E11s, provide grounding bushings. Terminate bonding jumper to ground rod and equipment grounding conductors.

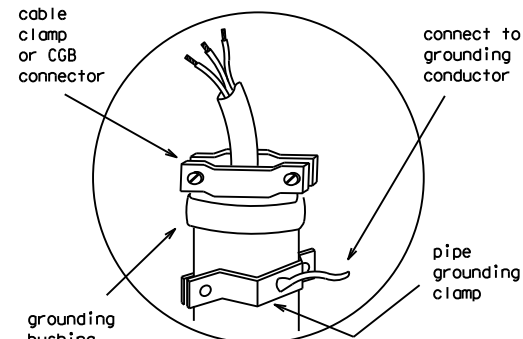

DETAIL D

Pull cable so opposite end connector is tight against conduit end, clamp cable at top of conduit as shown.

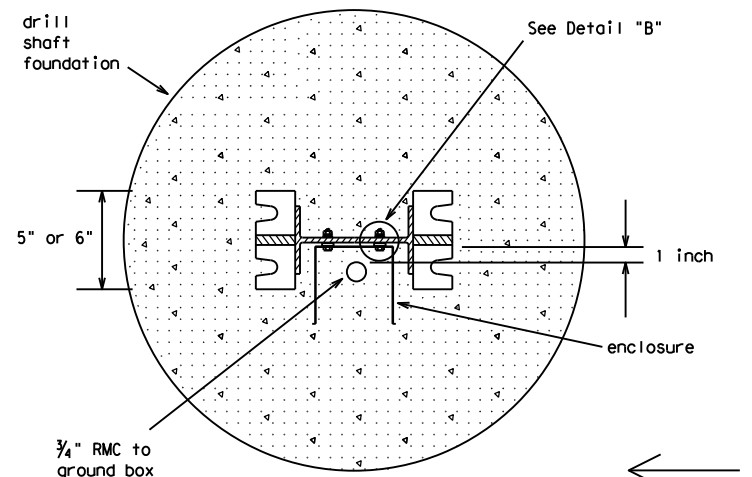

SECTION A-A

Stub-post connection conduit, bolts and enclosure (cover not shown)

direction of traffic

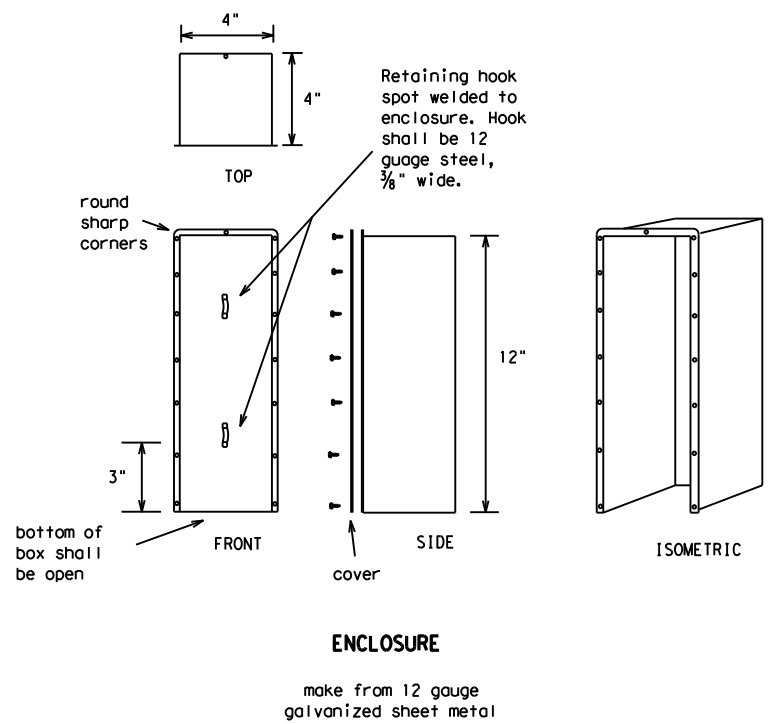

ENCLOSURE

make from 12 gauge galvanized sheet metal

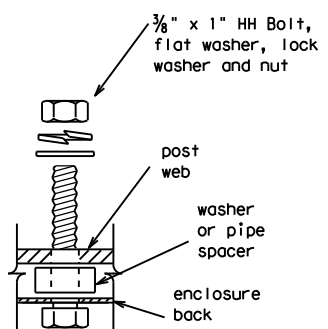

DETAIL B

enclosure connection (4 places)
 (use 2 inch bolt for 3 and 4 inch channels)

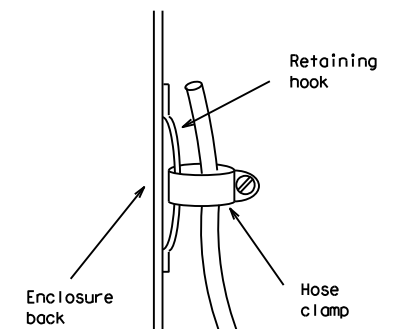

DETAIL E

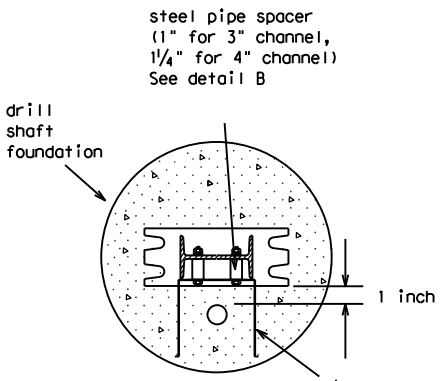

DETAIL A

Stub-post connection conduit, bolts and enclosure for 3 and 4 inch channel (cover not shown)

direction of traffic

NOTES:

- Breakaway connector shall be rated for 300 VAC, 30 amps and shall be waterproof. Connector shall be a three pole (two line conductors and neutral) polarized elastomer connector made from thermosetting synthetic polymer which remains flexible over the temperature range of -40 degrees C to 90 degrees C. The pins on the connector shall be overmolded 1/4" from the face of the connector toward the tips of the pins with the same material used in the construction of the connector body. This overmolding of the pins shall provide a non-conductive double taper which prevents the intrusion of water into the connection when the connectors are fully engaged. The pin receptors shall have current carrying barrels recessed 1/2" from the face of the connector and surrounded by beryllium copper spring sleeves. The plug/receptacle combination shall be listed by an approved testing facility (UL or Factory Mutual) as suitable for outdoor use and shall have passed a rain test and a watertight (immersion) test as approved by the Engineer.
- The female connector shall be integrally molded to a 13' length of type 50 cord containing three number 10 or number 8 AWG conductors. The male connector shall be integrally molded to a 20' length of Type 50 cord containing three number 10 or number 8 AWG conductors. Cord conductors shall have colored insulation, two black and one white, or shall be taped or painted to be two black and one white. Tape or paint marking shall cover entire exposed length. The contractor shall make a brochure submittal on cord connectors. Breakaway connector and cord shall not be paid for separately, but shall be subsidiary to the various items.
- The contractor shall install in-line waterproof fuseholders for each line conductor in the ground box. Fuses shall be fast-acting 5 amp (Bussman KTK5, Gould ATM5, Littlefuse KLK5 or equal).
- ⚠ Conduit shall convert to 3/4" liquidtight flexible metallic conduit below the fuse plate or knee joint and shall revert to 3/4" RMC above the fuse plate or knee joint. The length of liquidtight flexible metal conduit shall not exceed 6".
- Ground rod clamp shall be Blackburn GG 5/8H, Weaver W5.8 or equal.
- Ground rod to be driven to a depth to leave between 2 to 4 inches of rod above the gravel placed under the ground box. See ED(2) standard sheet for ground box details.

11-01 Revision
 ⚠ Liquidtight conduit size corrected.
 ⚠ Editing of minor notes.



**SIGN MOUNTING DETAILS-
 LARGE ROADSIDE SIGNS
 ELECTRICAL CONNECTION**

SMD(2-6)-01

© TxDOT April 1998		DN: TxDOT	CK: TxDOT	DW: TxDOT	CK: TxDOT
11-98	REVISIONS	CONT	SECT	JOB	HIGHWAY
11-01		0095	14	033, ETC	IH 20, ETC
		DIST	COUNTY	SHEET NO.	
		DAL	KAUFMAN, ETC	291	

DISCLAIMER: The use of this standard is governed by the "Texas Engineering Practice Act". No warranty of any kind is made by TxDOT for any purpose whatsoever. TxDOT assumes no responsibility for the conversion of this standard to other formats or for incorrect results or damages resulting from its use.

DATE: 3/1/2023 4:32:13 PM
 FILE: T:\DAL\TRAFFIC\2023 PS&E\I.H. 20\Plan Set\Standards\non-paf_standards\292_SMD(TY G)-08.dgn

WING CHANNEL CLAMP DETAIL FOR TYPE G MOUNT

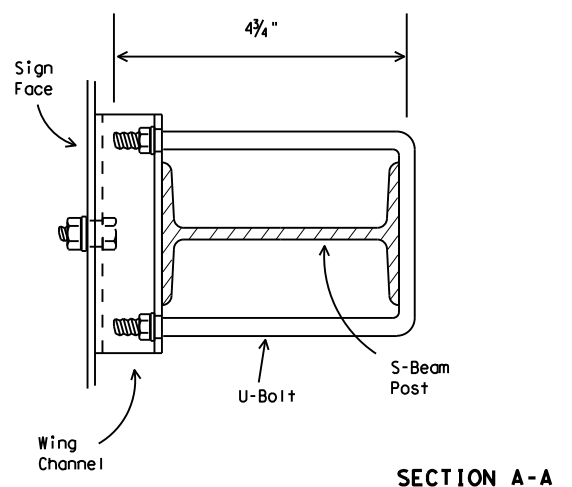
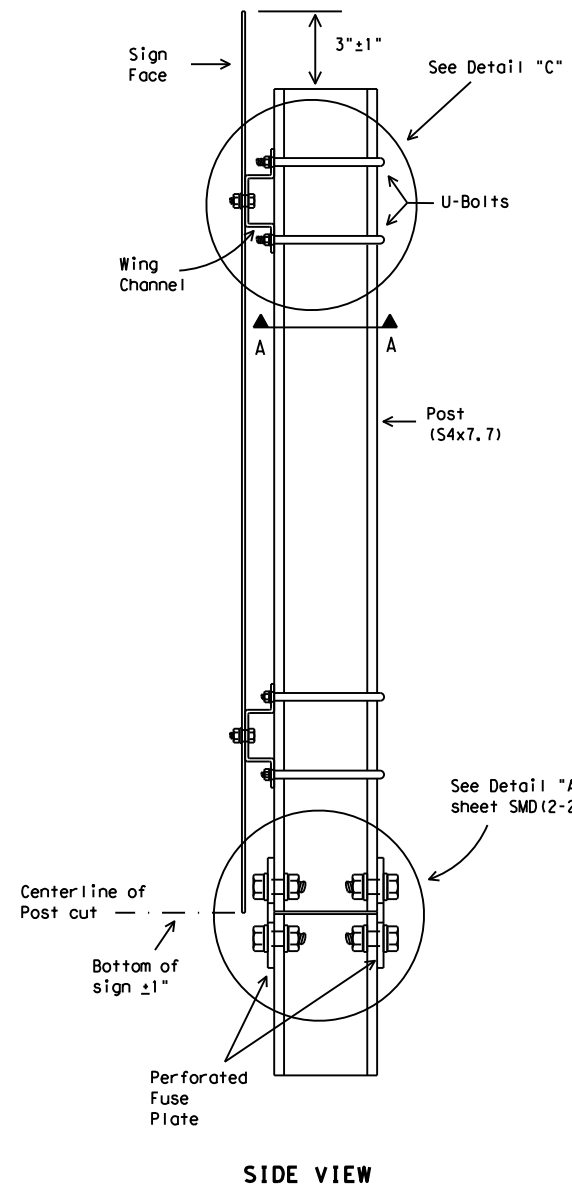

SECTION A-A

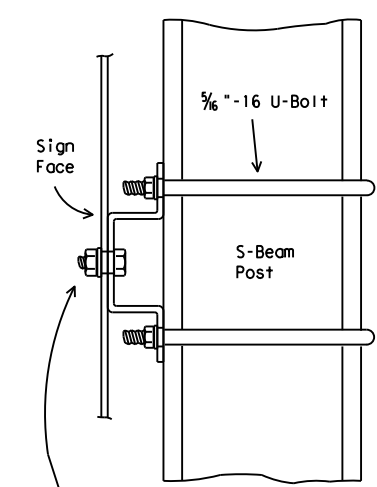

Galvanized steel or aluminum self-locking hex. head nut. 3/8" - 16 x 3/4" hex. head bolt for sheet metal. 3/8" - 16 x 1 1/4" hex. head bolt for plywood. 3/8" galvanized medium washer.

DETAIL "C"

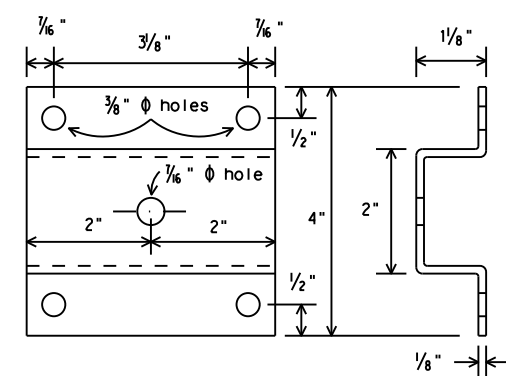

WING CHANNEL

Wing channel, 4" width x 1/8" depth x 1/8" thickness, shall be aluminum (ASTM B221 6061-T6 or B308 6061-T6), galvanized steel (ASTM A36) or stainless steel (ASTM A167 type 304, No. 2B finish).

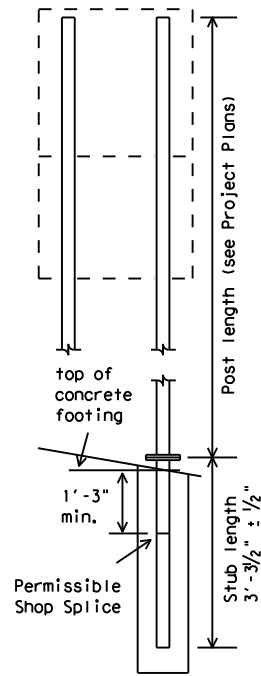

The weight of one S4x7.7 post is equal to 112.2 lbs. plus 7.7 lbs./ft x (post length in feet minus 10 ft). The weight of 112.2 lbs. includes 10 feet of post length, post foundation stub, related connection plates, friction fuse plate, and all high strength bolts, nuts and washers.

30' or more desirable. May be reduced depending on cross section, viewing conditions and other related factors.

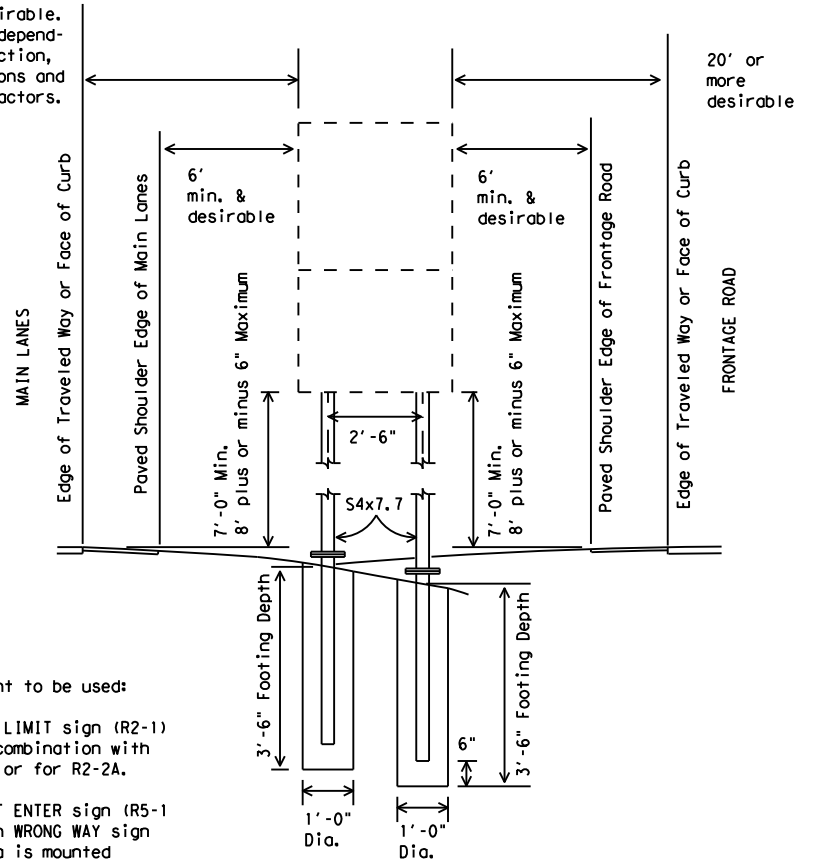

- This type mount to be used:
- (1) For SPEED LIMIT sign (R2-1) when used in combination with R2-2 and R2-4 or for R2-2A.
 - (2) For DO NOT ENTER sign (R5-1) when used with WRONG WAY sign (R5-1a). R5-1a is mounted above R5-1.

DEPARTMENTAL MATERIAL SPECIFICATIONS SIGN HARDWARE		DMS-7120
---	--	----------

- GENERAL NOTES:
1. Design conforms with AASHTO Specifications for the design and construction of structural supports for highway signs.
 2. Materials and fabrication shall conform to the requirements of the Department material specifications.
 3. Structural steel shall be "Low-Alloy Steel" for non-bridge structures per Item 442, "Metal For Structures."
 4. Parts shall be saw cut either before galvanizing and the galvanized cut cleaned of zinc build-up, or saw cut after galvanizing and the cut surface repaired per Item 445, "Galvanizing." (Cut surface will not be treated until plate is installed and all bolts fully tightened.)



SIGN MOUNTING DETAILS, TYPE G SUPPORT

SMD(TY G)-08

© TxDOT August 1995		DN: TxDOT	CK: TxDOT	DW: TxDOT	CK: TxDOT
1-97	REVISIONS	CONT	SECT	JOB	HIGHWAY
9-08		0095	14	033, ETC	IH 20, ETC
		DIST	COUNTY	SHEET NO.	
		DAL	KAUFMAN, ETC	292	

DISCLAIMER: The use of this standard is governed by the "Texas Engineering Practice Act". No warranty of any kind is made by TxDOT for any purpose whatsoever. TxDOT assumes no responsibility for the conversion of this standard to other formats or for incorrect results or damages resulting from its use.

FILE: T:\DAL\TRAFFIC\2023 PS&E\I\H 20\N\Plan_Sets\Standards\non-paf_standards\29338294_SMD (8W1) & (8W2)-08.dgn

DATE: 3/1/2023 4:32:14 PM
FILE: T:\DAL\TRAFFIC\2023 PS&E\I\H 20\N\Plan_Sets\Standards\non-paf_standards\29338294_SMD (8W1) & (8W2)-08.dgn

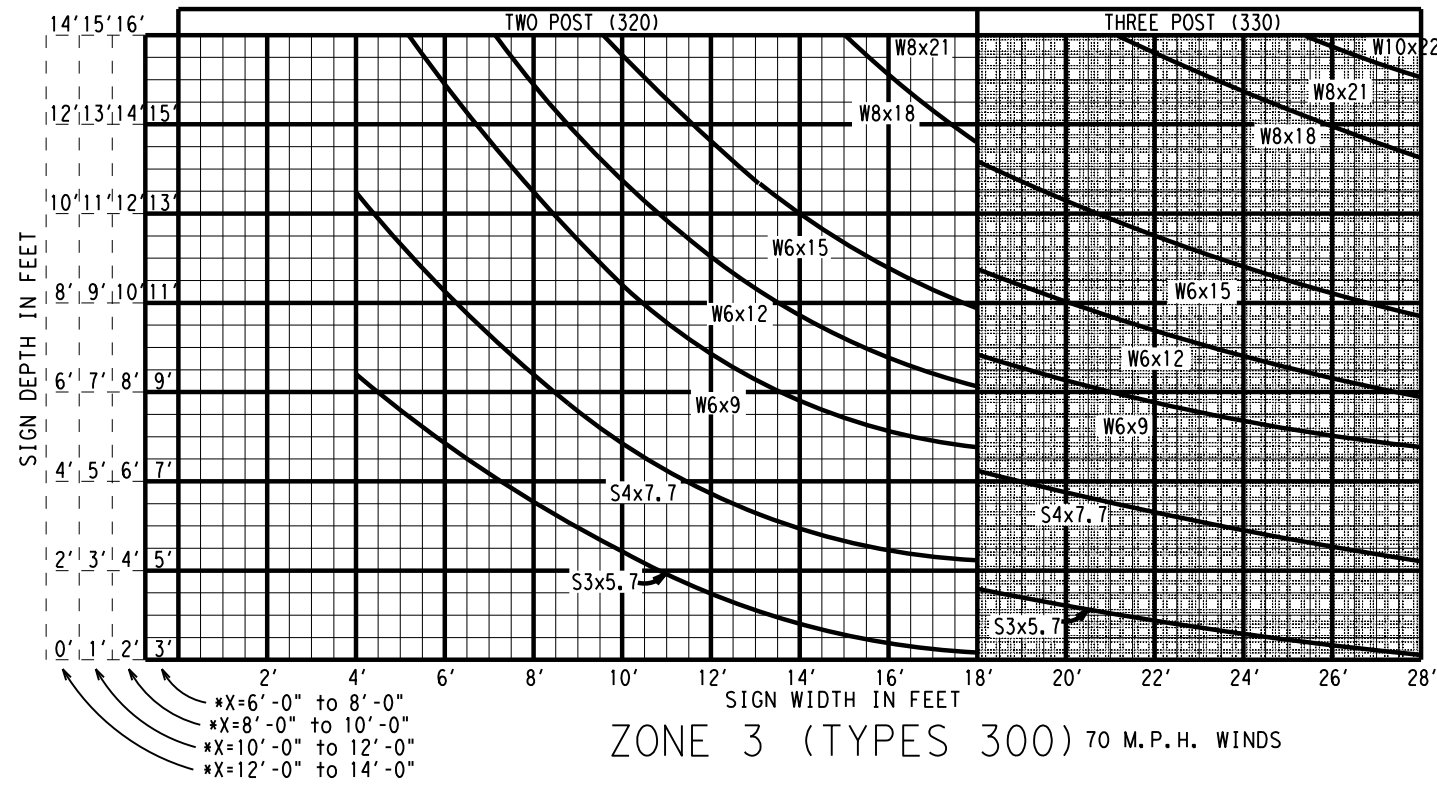
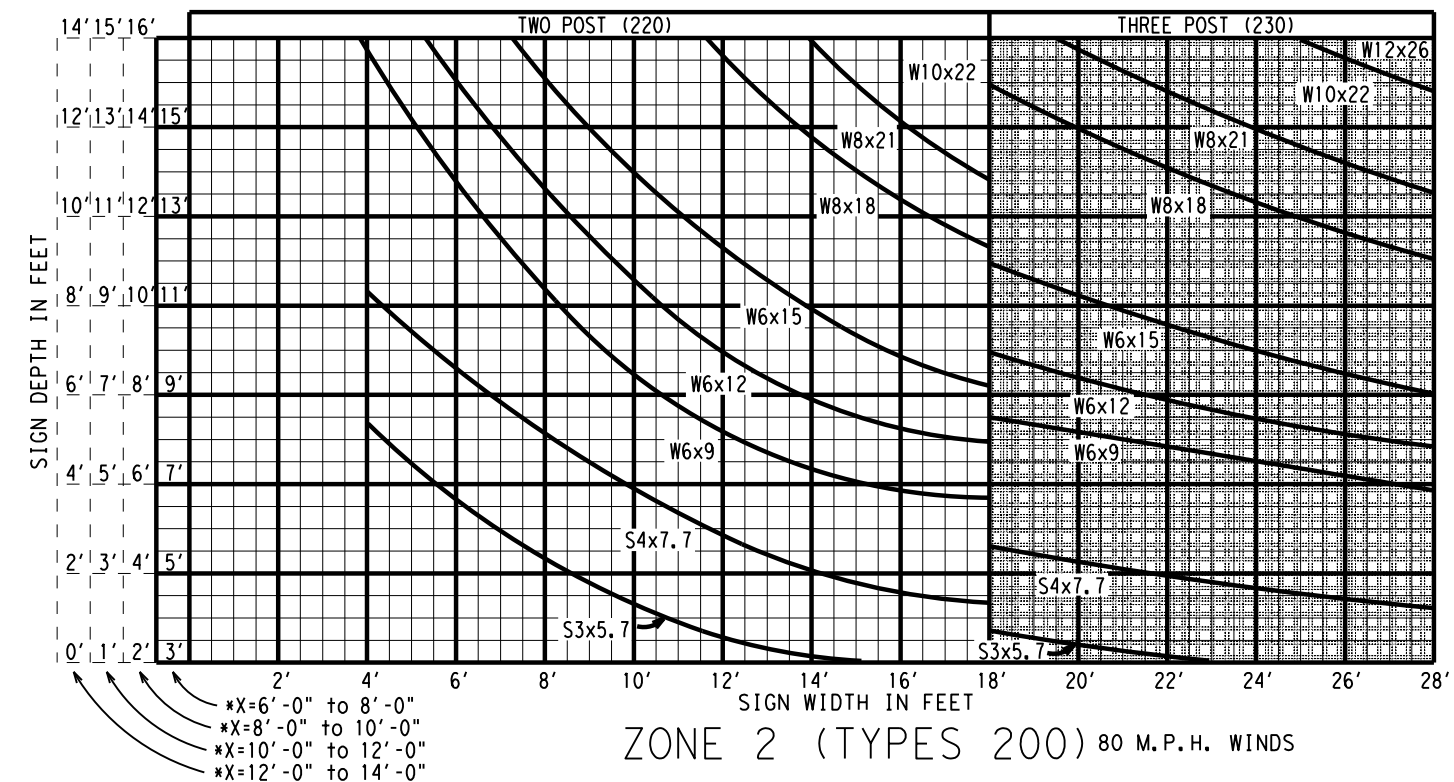
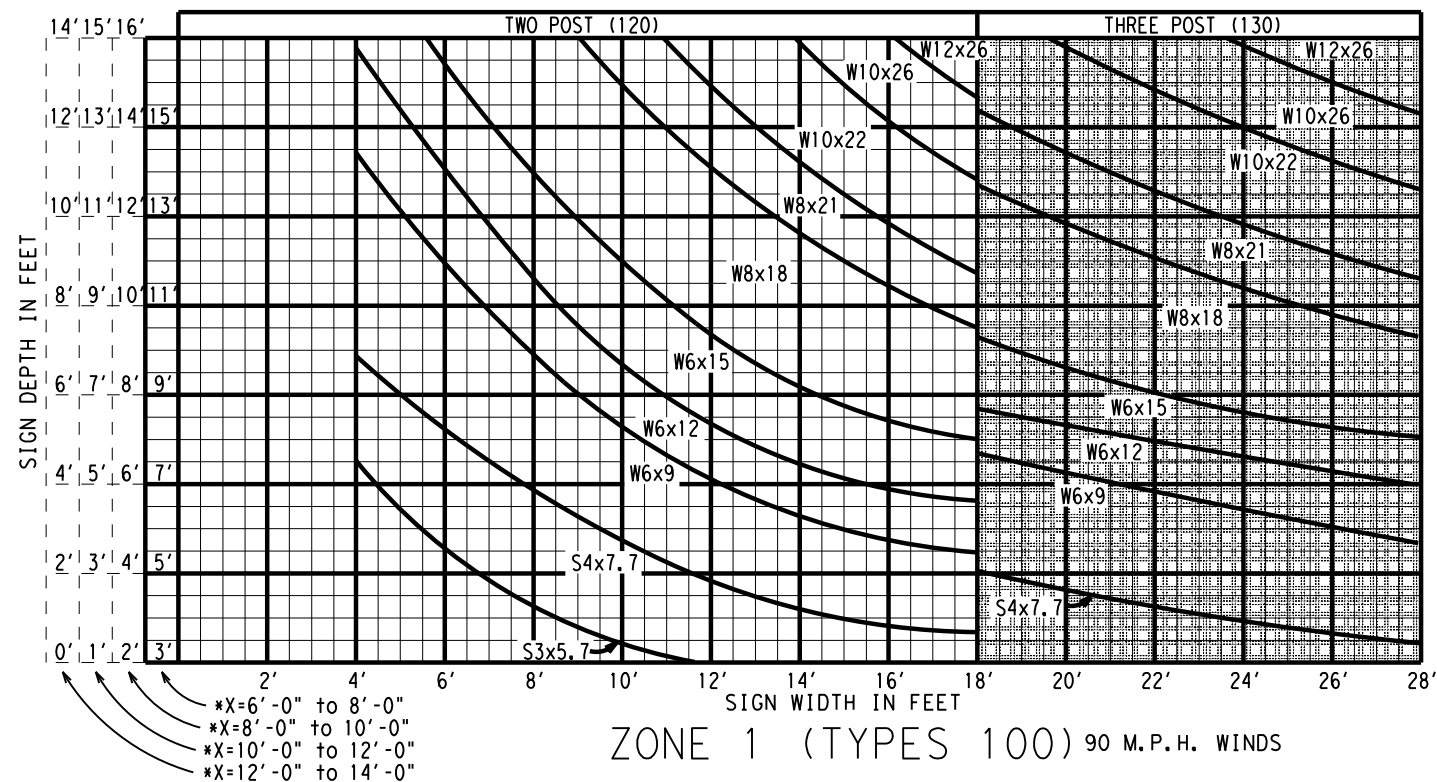

* NOTE: "X" EQUALS THE AVERAGE HEIGHT FROM THE GROUND LINE TO THE BOTTOM EDGE OF THE SIGN.

SHADED AREA DENOTES 3 POST SUPPORTS

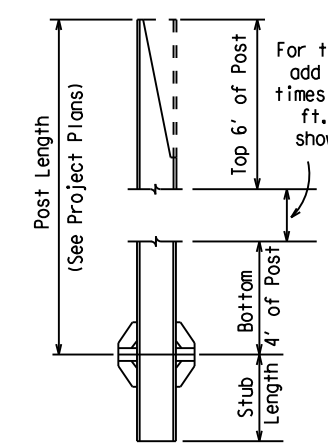

For total post wt. add this length times post wt. per ft. to weight shown in table

POST SIZE	WEIGHT OF ONE POST (#)	WEIGHT OF TWO POSTS (#)	WEIGHT OF THREE POSTS (#)
W6x9*	123.2	246.4	369.6
W6x12*	160.3	320.6	480.9
W6x15*	167.8	335.6	503.4
W8x18*	201.8	403.6	605.4
W8x21*	254.7	509.4	764.1
W10x22*	266.0	532.0	798.0
W10x26*	308.0	616.0	924.0
W12x26*	308.6	617.2	925.8
S3x5.7*	85.9	171.8	257.7
S4x7.7*	112.2	224.4	336.6

*LAST FIGURES=POST WT. PER FT.

Weight Data is the weight of items shown for one, two or three posts - (includes top 6' of post, bottom 4' of post, post foundation stub, related base connection plates and stiffeners, friction fuse plate and all high strength bolts, nuts and washers).

SIGN TYPE

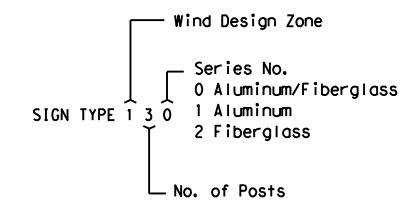

Note: Footings for S3x5.7 and S4x7.7 post sizes shall be non-reinforced with Class A concrete, while footing for all other post sizes shall be reinforced with Class C concrete.

Texas Department of Transportation
 Traffic Operations Division

**LARGE ROADSIDE SIGN SUPPORTS
 POST SELECTION
 WORKSHEET**

SMD (8W1) - 08

© TxDOT July 1978	DN: TxDOT	CK: TxDOT	DW: TxDOT	CK: TxDOT
1-82	CONTRACT	SECTION	JOB	HIGHWAY
5-01	0095 14		033, ETC	IH 20, ETC
9-08	DIST	COUNTY	SHEET NO.	
	DAL	KAUFMAN, ETC	293	

DISCLAIMER: The use of this standard is governed by the "Texas Engineering Practice Act". No warranty of any kind is made by TxDOT for any purpose whatsoever. TxDOT assumes no responsibility for the conversion of this standard to other formats or for incorrect results or damages resulting from its use.

DISCLAIMER: The use of this standard is governed by the "Texas Engineering Practice Act". No warranty of any kind is made by TxDOT for any purpose whatsoever. TxDOT assumes no responsibility for the conversion of this standard to other formats or for incorrect results or damages resulting from its use.

DATE: 3/1/2023 4:32:15 PM
 FILE: T:\DAL\TRAFFIC\FY_2023_PS&E\I\H_20\N\Plan_Set\Standards\non-paf_standards\2938294_SMD(8W1) & (8W2)-08.dgn

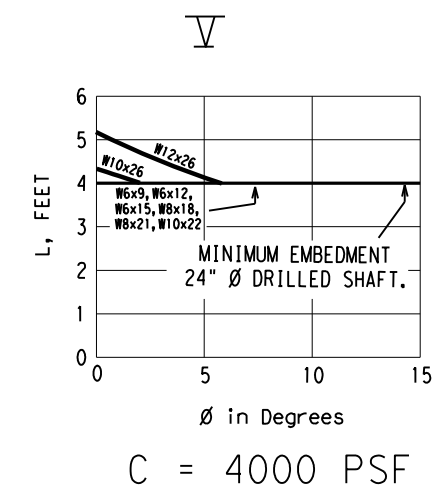
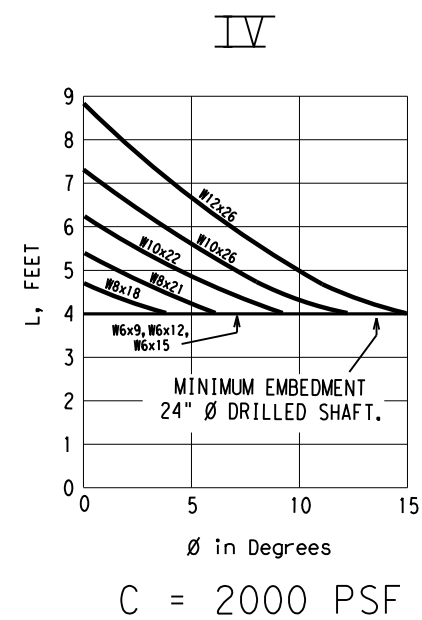
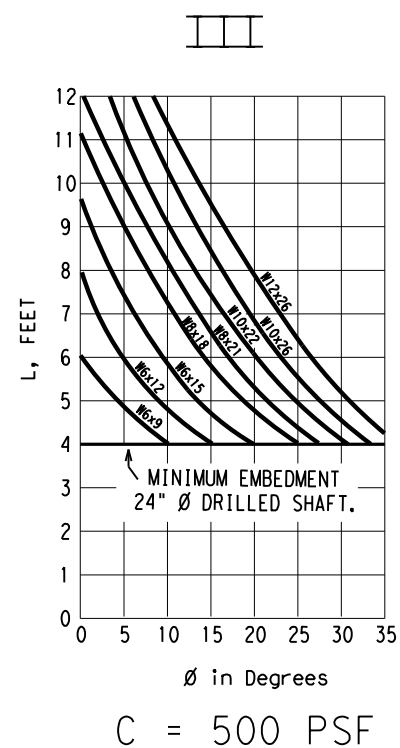
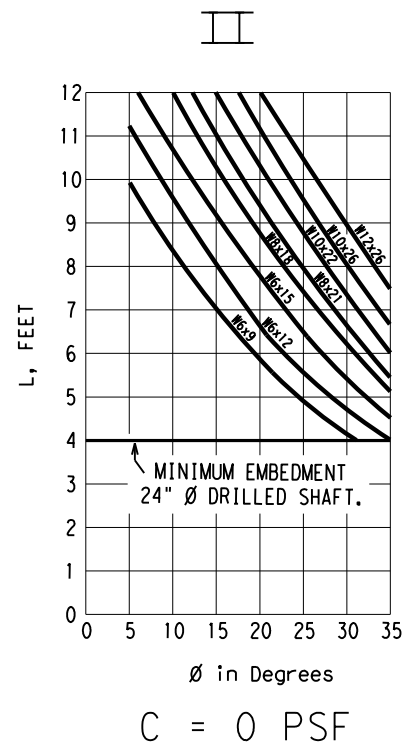
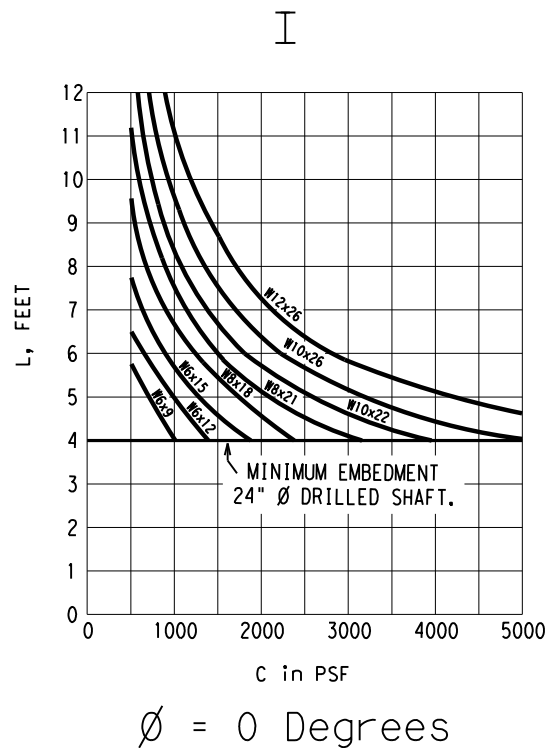

LEGEND:

L = Required embedment of concrete drilled shaft, in feet
 C = Cohesive shear strength of soil, in psf
 phi = Angle of internal friction of soil, in degrees

For values of C and phi which are intermediate to those on the charts, embedments may be determined by straight-line interpolation.

DRILLED CONCRETE FOOTING DEPTH CHART (COHFRIC DESIGN)

NOTE: THESE CHARTS MAY BE USED AS AN ALTERNATE TO THE CHART BELOW, PROVIDED THAT SOIL COHESION AND INTERNAL FRICTION (COHFRIC) DATA ARE AVAILABLE.

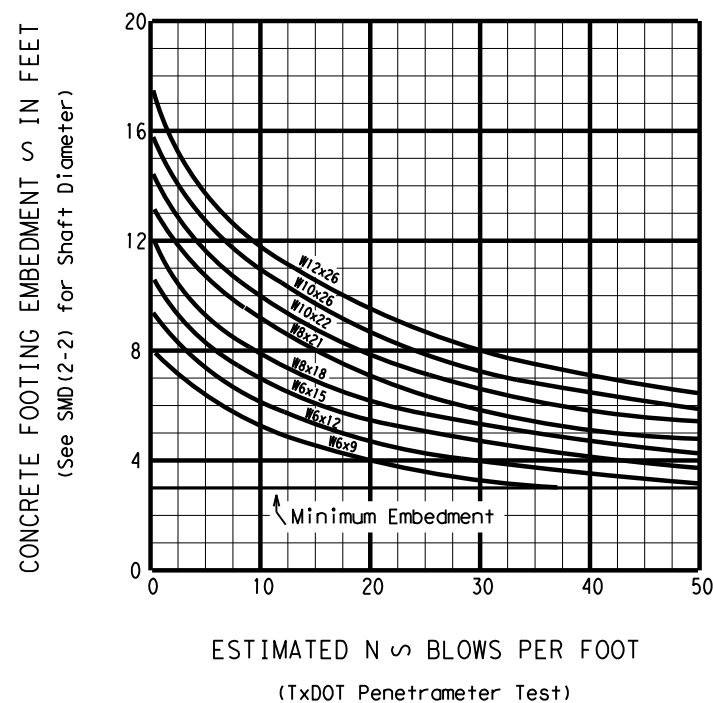

DRILLED CONCRETE FOOTING DEPTH CHART (TXDOT PENETROMETER DESIGN)

NOTE: ESTIMATED N SHOULD BE BASED AT APPROXIMATELY THE UPPER ONE-THIRD POINT OF THE DRILLED CONCRETE FOOTING BELOW THE GROUND LINE

Note:
 1. Curves shown on this sheet are applicable for reinforced concrete footings only.

Texas Department of Transportation
 Traffic Operations Division

LARGE ROADSIDE SIGN SUPPORTS FOUNDATION WORKSHEET

SMD (8W2) - 08

© TxDOT July 1972		DN: TxDOT	CK: TxDOT	DW: TxDOT	CK: TxDOT
REVISIONS		CONT	SECT	JOB	HIGHWAY
5-74		0095	14	033, ETC	IH 20, ETC
4-78					
9-08		DIST	COUNTY	SHEET NO.	
		DAL	KAUFMAN, ETC	294	

DATE: 3/1/2023 4:32:16 PM
 FILE: T:\DAL\TRAFFIC\2023 PS&E\I.H. 20\Plan Set\Standards\non-paf_standards.dwg
 PS&E\I.H. 20\Plan Set\Standards\non-paf_standards.dwg

APPLICABLE STANDARDS SHEETS

- OVERHEAD SIGN BRIDGE STANDARDS:
 OSB-SE
 OSB-Z#
 OSB-Z#1
 HOSB-Z#
 HOSB-Z1L
 HOSB-Z#1
 OSBT
 OSBC
 OSBC-SC-Z#
 OSBS-SC
 OSB-FD
 OSB-FD-SC
- HIGH MAST ILLUMINATION POLE STANDARDS:
 HMIP-98
 HMIF-98
- WALKWAYS AND BRACKETS STANDARDS:
 SWW
 SB(SWL-1)
- TRAFFIC SIGNAL POLE STANDARDS:
 SP-80
 SP-100
 SMA-80
 SMA-100
 DMA-80
 DMA-100
 MA-C
 MAC (ILSN)
 MAD-D
 TS-FD
 LUM-A
 CFA
 LMA
 TS-C
 MA-DPD
- CANTILEVER OVERHEAD SIGN SUPPORT STANDARDS:
 COSS-SE
 COSS-Z#-10
 HCOSS-Z#-10
 COSS-Z21-10
 COSS-Z#&Z#1-10
 COSSD
 COSSF
 COSS-FD
- Note: # = Wind Zone number 1, 2, 3 or 4

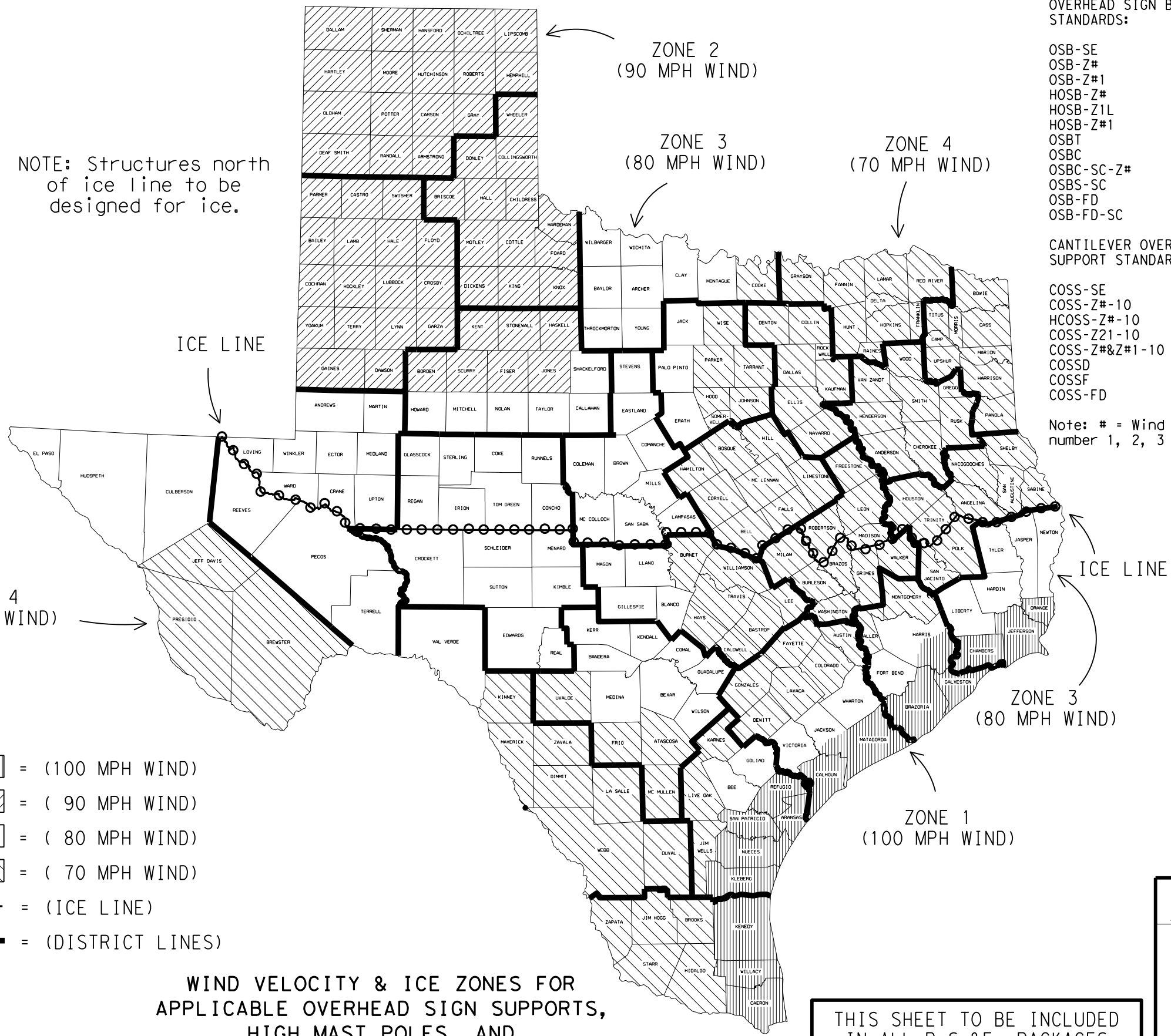

NOTE: Structures north of ice line to be designed for ice.

LEGEND

- ZONE 1 - [diagonal lines] = (100 MPH WIND)
- ZONE 2 - [diagonal lines] = (90 MPH WIND)
- ZONE 3 - [white box] = (80 MPH WIND)
- ZONE 4 - [diagonal lines] = (70 MPH WIND)
- [dashed line with circles] = (ICE LINE)
- [solid black line] = (DISTRICT LINES)

WIND VELOCITY & ICE ZONES FOR APPLICABLE OVERHEAD SIGN SUPPORTS, HIGH MAST POLES, AND TRAFFIC SIGNAL POLES
 Based on 50 Year Mean Recurrence Interval of Fastest Mile Wind Velocity at 33 feet height.

THIS SHEET TO BE INCLUDED IN ALL P.S.&E. PACKAGES CONTAINING ONE OR MORE OF THE APPLICABLE STANDARD SHEETS LISTED HEREON

FOR HARRIS CO. ONLY
 Zone line is just North of US 90, around on the North, West and South sides of IH 610 and down the West side of SH 288.

FOR JACKSON CO. ONLY
 Zone line is just North of SH 616.

		Traffic Operations Division Standard	
<h2>WIND VELOCITY AND ICE ZONES</h2> <h3>WV & IZ-14</h3>			
FILE:	windice.dgn	DN: TxDOT	CK: TxDOT
© TxDOT	April 1996	CONT	SECT
REVISIONS	0095	14	033, ETC
8-14-Added list of applicable standards, restricting use to structures designed for Fastest Mile wind speeds.	DIST	COUNTY	SHEET NO.
	DAL	KAUFMAN, ETC	295

ZONE 4 WITH AND WITHOUT ICE 70 MPH WIND

TOWER HEIGHT (ft)	10' SPAN										15' SPAN										20' SPAN										25' SPAN										TOWER HEIGHT (ft)													
	TOWER PIPE		ANCHOR BOLTS		BASE PLATE	TRUSS	DESIGN LOADS				TOWER PIPE		ANCHOR BOLTS		BASE PLATE	TRUSS	DESIGN LOADS				TOWER PIPE		ANCHOR BOLTS		BASE PLATE	TRUSS	DESIGN LOADS				TOWER PIPE		ANCHOR BOLTS		BASE PLATE	TRUSS	DESIGN LOADS																	
	O.D. (in)	WALL THICK (in)	DEFL ΔH (in)	SIZE DIA (in)	NO.	BOLT CIR DIA	SIZE (in)	DEFL ΔV (in)	SHEAR V (Kips)	TORSION T (K-ft)	MOMENT M (K-ft)	O.D. (in)	WALL THICK (in)	DEFL ΔH (in)	SIZE DIA (in)	NO.	BOLT CIR DIA	SIZE (in)	DEFL ΔV (in)	SHEAR V (Kips)	TORSION T (K-ft)	MOMENT M (K-ft)	O.D. (in)	WALL THICK (in)	DEFL ΔH (in)	SIZE DIA (in)	NO.	BOLT CIR DIA	SIZE (in)	DEFL ΔV (in)	SHEAR V (Kips)	TORSION T (K-ft)	MOMENT M (K-ft)	O.D. (in)	WALL THICK (in)	DEFL ΔH (in)	SIZE DIA (in)	NO.	BOLT CIR DIA	SIZE (in)		DEFL ΔV (in)	SHEAR V (Kips)	TORSION T (K-ft)	MOMENT M (K-ft)	O.D. (in)	WALL THICK (in)	DEFL ΔH (in)	SIZE DIA (in)	NO.	BOLT CIR DIA	SIZE (in)	DEFL ΔV (in)	SHEAR V (Kips)
14'	16	0.250	0.104	1 1/4	6	20 1/2"	24 x 1 1/4"	0.2	2.75	12.39	38.53	16	0.250	0.234	1 3/8	6	20 3/4"	24 1/2 x 1 1/4"	0.5	4.13	28.76	59.63	16	0.250	0.419	1 3/4	6	21 1/2"	26 x 1 3/4"	1.3	5.59	52.67	83.06	20	0.250	0.333	1 3/8	8	24 3/4"	28 1/2 x 1 3/8"	1.4	7.00	82.44	107.23	14'									
15'			0.119						2.76		41.23			0.268				24 1/2 x 1 1/4"	0.6	4.14		63.62		0.250	0.481					1.4	5.61		88.34		0.382					1.5	7.02		113.64	15'										
16'			0.136						2.77		43.94			0.305				24 1/2 x 1 3/8"	0.6	4.16		67.63		0.250	0.547					1.5	5.62		93.66		0.435					1.6	7.03		120.14	16'										
17'			0.153						2.79		46.68			0.345	1 3/8	20 3/4"	24 1/2 x 1 3/8"	0.6	4.17		71.67		0.281	0.549					1.4	5.63		99.03		0.491					1.7	7.05		126.71	17'											
18'			0.172						2.80		49.43			0.386	1 1/2	21"	25 x 1 3/8"	0.7	4.18		75.74			0.615				1.5	5.64		104.44		0.550	1 3/8	24 3/4"	28 1/2 x 1 3/8"	1.7	7.07		133.34	18'													
19'			0.191						2.81		52.20			0.431			25 x 1 1/2"	0.7	4.20		79.83			0.685				1.5	5.66		109.88		0.613	1 1/2	25"	29 x 1 1/2"	1.8	7.08		140.03	19'													
20'			0.212						2.83		54.99			0.477				0.7	4.21		83.94		0.281	0.759			26 x 1 3/4"	1.6	5.67		115.36		0.679					1.9	7.10		146.77	20'												
21'			0.234						2.84		57.79			0.526				0.8	4.22		88.08		0.310	0.759			26 x 2	1.5	5.68		120.86		0.749					2.0	7.12		153.56	21'												
22'			0.257					0.2	2.85		60.61			0.577		6	25 x 1 1/2"	0.8	4.23		92.23			0.834				1.6	5.70		126.40		0.803			29 x 1 1/2"		7.13		160.39	22'													
23'			0.280					0.3	2.87		63.45			0.631		8	25 x 1 5/8"	0.9	4.25		96.40			0.911				1.7	5.71		131.96		0.874			29 x 1 5/8"		7.15		167.26	23'													
24'			0.305						2.88		66.30			0.687				0.9	4.26		100.60		0.310	0.992				1.7	5.77		138.12		0.874	1 1/2	25"			7.16		174.17	24'													
25'			0.331	1 1/4		20 1/2"	24 x 1 1/4"		2.89		69.16			0.745				0.9	4.27		104.81		0.340	0.990					5.73		143.15		0.949	1 3/4	25 3/8"			7.18		181.12	25'													
26'			0.358	1 3/8		20 3/4"	24 1/2 x 1 3/8"		2.90		72.04			0.806				1.0	4.29		109.03		0.340	1.071				1.7	5.75		148.78		0.920			29 x 1 3/8"	2.1	7.20		188.02	26'													
27'			0.386						2.92		74.93			0.869					4.30		113.28		0.340	1.155				1.8	5.76		154.43		0.992			29 3/4 x 1 3/4"		7.21		195.03	27'													
28'			0.416						2.93		77.84	0.250		0.935				4.31		117.54		0.375	1.139				1.7	5.77		160.10		1.067			29 3/4 x 1 3/4"		7.23		202.07	28'														
29'			0.446						2.94		80.76	0.280		0.898				4.33		121.82		0.375	1.221				1.8	5.79		165.79		0.312	1.145		29 3/4 x 1 3/4"	2.1	7.24		209.14	29'														
30'			0.477	1 3/8		20 3/4"	24 1/2 x 1 3/8"		2.96		83.69			0.961				4.34		126.11		0.375	1.307					5.80		171.49		0.344	1.119		29 3/4 x 2	2.2	7.26		216.23	30'														
31'			0.509	1 1/2		21"	25 x 1 1/2"		2.97		86.64			1.026				1.0	4.35		130.42		0.410	1.297				5.81		177.22		0.344	1.194		29 3/4 x 2	2.2	7.28		223.35	31'														
32'	16	0.250	0.543	1 1/2	6	21"	25 x 1 1/2"	0.3	2.98	12.39	89.61	16	0.280	1.094	1 1/2	8	21"	25 x 1 5/8"	1.1	4.36	28.76	134.74	16	0.410	1.382	1 3/4	8	21 1/2"	26 x 2	1.8	5.83	52.67	182.97	20	0.344	1.273	1 3/4	8	25 3/8"	29 3/4 x 2	2.2	7.29	82.44	230.50	32'									

ZONE 4 WITH AND WITHOUT ICE 70 MPH WIND

TOWER HEIGHT (ft)	30' SPAN										35' SPAN										40' SPAN										TOWER HEIGHT (ft)												
	TOWER PIPE		ANCHOR BOLTS		BASE PLATE	TRUSS	DESIGN LOADS				TOWER PIPE		ANCHOR BOLTS		BASE PLATE	TRUSS	DESIGN LOADS				TOWER PIPE		ANCHOR BOLTS		BASE PLATE	TRUSS	DESIGN LOADS																
	O.D. (in)	WALL THICK (in)	DEFL ΔH (in)	SIZE DIA (in)	NO.	BOLT CIR DIA	SIZE (in)	DEFL ΔV (in)	SHEAR V (Kips)	TORSION T (K-ft)	MOMENT M (K-ft)	O.D. (in)	WALL THICK (in)	DEFL ΔH (in)	SIZE DIA (in)	NO.	BOLT CIR DIA	SIZE (in)	DEFL ΔV (in)	SHEAR V (Kips)	TORSION T (K-ft)	MOMENT M (K-ft)	O.D. (in)	WALL THICK (in)	DEFL ΔH (in)	SIZE DIA (in)	NO.	BOLT CIR DIA	SIZE (in)	DEFL ΔV (in)		SHEAR V (Kips)	TORSION T (K-ft)	MOMENT M (K-ft)	O.D. (in)	WALL THICK (in)	DEFL ΔH (in)	SIZE DIA (in)	NO.	BOLT CIR DIA	SIZE (in)	DEFL ΔV (in)	SHEAR V (Kips)
14'	24	0.250	0.285	1 1/2	8	29"	33 x 1 1/2"	1.6	8.42	119.01	134.48	24	0.250	0.406	1 3/4	8	29 3/8"	33 3/4 x 1 1/2"	2.6	9.77	161.98	165.20	30	0.250	0.280	1 3/4	8	35 3/8"	39 3/4 x 1 1/2"	2.4	11.22	211.94	200.44	14'									
15'			0.327						1.6	8.44	141.90			0.467					2.7	9.79		173.37		0.250	0.322				2.5	11.24		209.33	15'										
16'			0.372						1.7	8.46	149.44			0.531					2.8	9.81		181.71		0.250	0.366				2.6	11.27		218.45	16'										
17'			0.420						1.8	8.48	157.10	0.250		0.599				33 3/4 x 1 1/2"	3.0	9.83		190.21		0.250	0.413				2.7	11.29		227.79	17'										
18'			0.471						1.9	8.50	164.85	0.281		0.602				33 3/4 x 1 3/8"	2.9	9.85		198.85		0.250	0.463				2.8	11.32		237.32	18'										
19'			0.524						2.0	8.52	172.68			0.671					3.0	9.87		207.61		0.250	0.516				2.9	11.34		247.01	19'										
20'			0.581						2.1	8.54	180.60			0.743					3.1	9.89		216.48		0.281	0.510				2.8	11.37		256.86	20'										
21'			0.641	1 1/2		29"	33 x 1 1/2"	2.2	8.56		188.59			0.820				33 3/4 x 1 5/8"	3.2	9.91		225.46		0.250	0.562				2.9	11.39		266.86	21'										
22'			0.703	1 3/4		29 3/8"	33 3/4 x 1 1/2"	2.2	8.58		196.65	0.281		0.900				33 3/4 x 1 3/4"	3.4	9.93		234.52		0.250	0.617				3.0	11.41		276.98	22'										
23'			0.768				33 3/4 x 1 1/2"	2.3	8.60		204.76	0.312		0.889				33 3/4 x 1 3/4"	3.2	9.95		243.67		0.250	0.675			39 3/4 x 1 1/2"	3.1	11.44		287.22	23'										
24'			0.837				33 3/4 x 1 5/8"	2.4	8.62		212.93			0.968	1 3/4	29 3/8"	33 3/4 x 1 3/4"	3.3	9.96		252.90		0.250	0.735	1 3/4	35 3/8"	39 3/4 x 1 5/8"	3.2	11.46		297.57	24'											
25'			0.908				33 3/4 x 1 3/8"	2.5	8.64		221.15			1.050	2	29 3/4"	34 1/2 x 1 3/8"	3.5	9.98		262.20		0.250	0.797	2	35 3/4"	40 1/2 x 1 5/8"	3.3	11.49		308.01	25'											
26'		0.250	0.982				33 3/4 x 1 5/8"	2.6	8.66		229.42			1.136					3.6	10.00		271.57		0.250	0.862			40 1/2 x 1 5/8"	3.4	11.51		318.55	26'										
27'		0.281	0.949				33 3/4 x 1 3/4"	2.4	8.67		237.74	0.312		1.225					3.7	10.02		280.99		0.250	0.930			40 1/2 x 1 5/8"	3.5	11.54		329.18	27'										
28'			1.021				33 3/4 x 1 3/4"	2.5	8.69		246.10	0.340		1.200				34 1/2 x 1 5/8"	3.5	10.04		290.48		0.250	1.000			40 1/2 x 1 3/4"	3.6	11.56		339.89	28'										
29'			1.095	1 3/4		29 3/8"	33 3/4 x 1 3/4"	2.6	8.71		254.49			1.287				34 1/2 x 2	3.6	10.06		300.02		0.250	1.073				3.7	11.58		350.68	29'										
30'			1.172	2		29 3/4"	34 1/2 x 1 3/4"	2.7	8.73		262.93			1.377					3.7	10.08		309.61		0.250	1.148				3.8	11.61		361.53	30'										
31'			1.251	2		29 3/4"	34 1/2 x 1 3/4"	2.8	8.75		271.41			1.471					3.8	10.10		319.25		0.250	1.226				3.9	11													

DISCLAIMER: The use of this standard is governed by the "Texas Engineering Practice Act". No warranty of any kind is made by TxDOT for any purpose whatsoever. TxDOT assumes no responsibility for the conversion of this standard to other formats or for incorrect results or damages resulting from its use.

DATE: 3/1/2023 4:32:18 PM
 FILE: I:\DAL\TRAFFIC\2023 PS&E\I\H 20\Plan_Set\Standards\non-paf_standards\297&298 COSSD.dgn

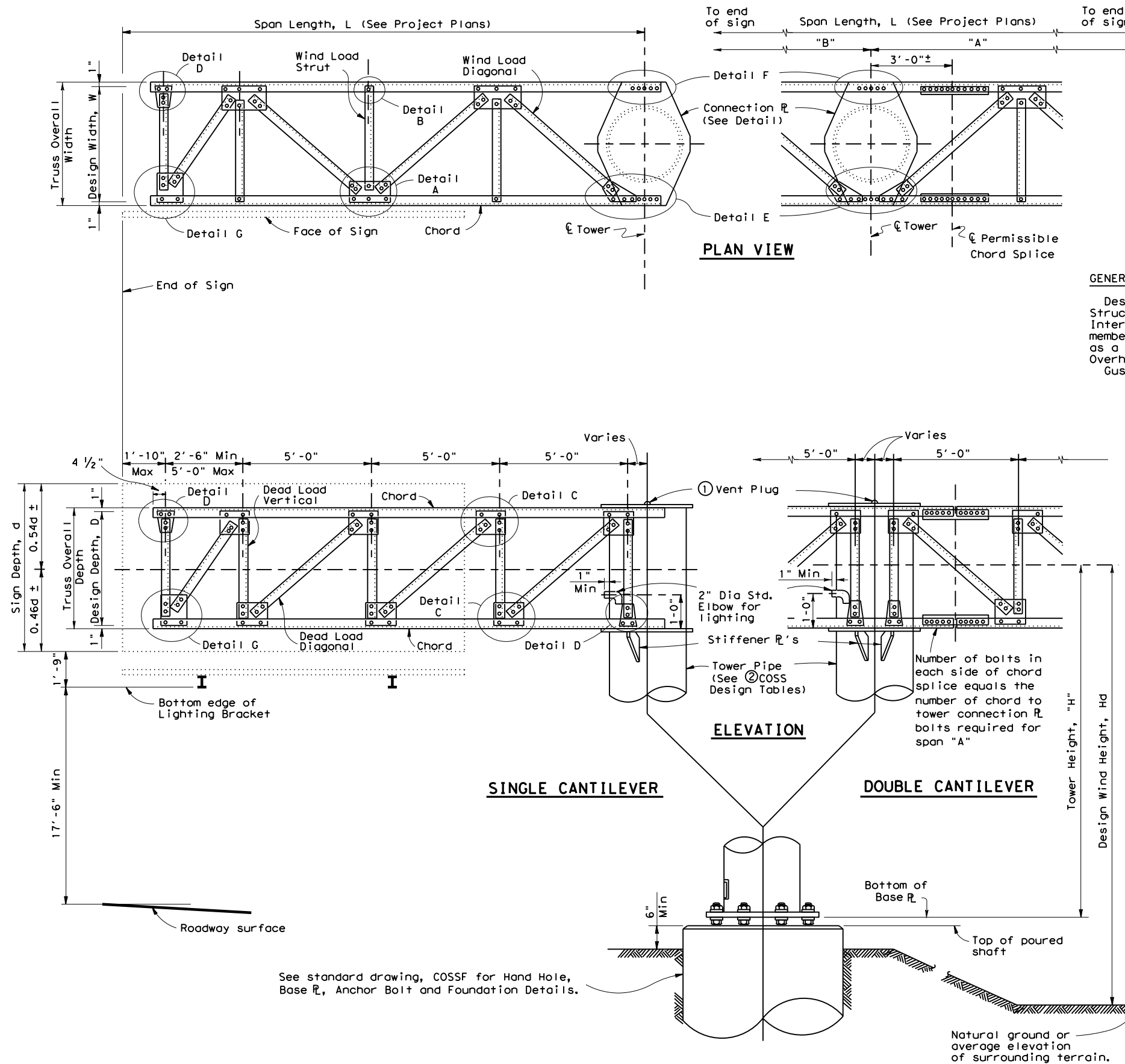

GENERAL NOTES:

Design conforms to 1975 AASHTO Standard Specifications for Structural Supports for Highway Signs, Luminaires and Traffic Signals and Interim revisions thereto. Connection details are typical only. Actual size of member and number of bolts will vary. The details on this sheet are intended as a guide only. See "Cantilever Overhead Sign Supports" or "High Level Cantilever Overhead Sign Supports" sheets for number of bolts and size of members. Gusset plates to be same thickness as thickest web member in connection.

- ① Note: Cap shall be solid steel sheet $\frac{3}{8}$ " nominal thickness. Drill, tap and plug galvanizing vent. Weld plate to pipe with $\frac{3}{8}$ " weld all around.
- ② For COSS design tables see standard drawing, "Cantilever Overhead Sign Supports" or "High Level Cantilever Overhead Sign Supports".

SHEET 1 OF 2



CANTILEVER OVERHEAD SIGN SUPPORT DETAILS

COSSD

© TxDOT November 2007		DN: TxDOT	CK: TxDOT	DW: TxDOT	CK: TxDOT
REVISIONS					
CONT	SECT	JOB		HIGHWAY	
0095	14	033, ETC		IH 20, ETC	
DIST		COUNTY		SHEET NO.	
DAL		KAUFMAN, ETC		297	

DISCLAIMER: The use of this standard is governed by the "Texas Engineering Practice Act". No warranty of any kind is made by TxDOT for any purpose whatsoever. TxDOT assumes no responsibility for the conversion of this standard to other formats or for incorrect results or damages resulting from its use.

DATE: 3/11/2023 4:32:18 PM
 FILE: I:\DAL\TRAFFIC\2023 PS&E\I.H. 20\Plan Set\Standards\non-paf_standards\297&298 COSSD.dgn

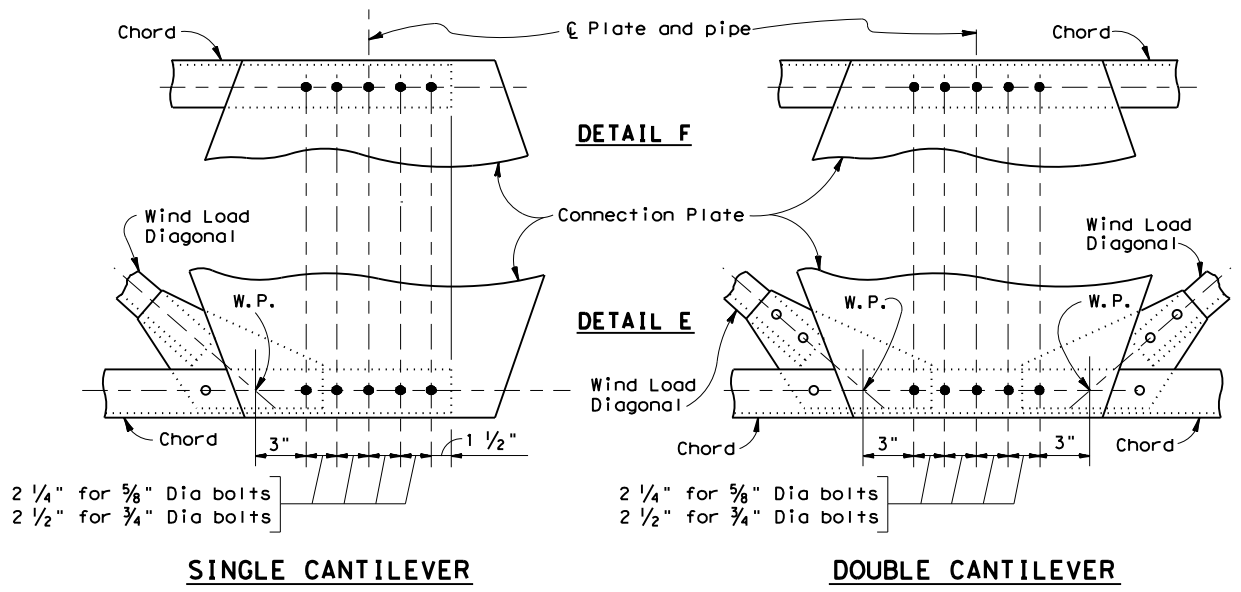

SINGLE CANTILEVER **DOUBLE CANTILEVER**

CONNECTION DETAILS

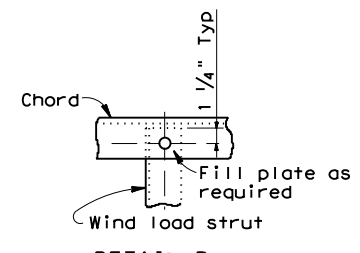

DETAIL B

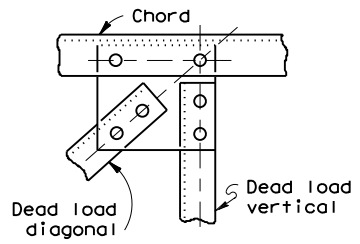

DETAIL C

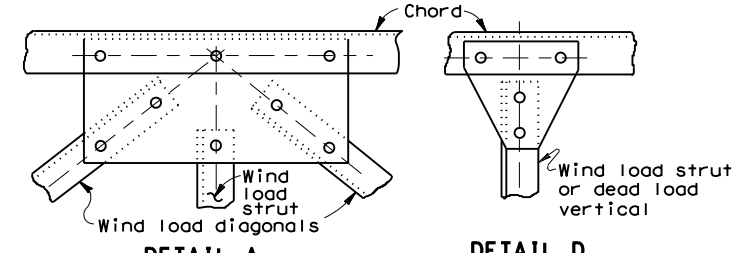

DETAIL A

DETAIL D

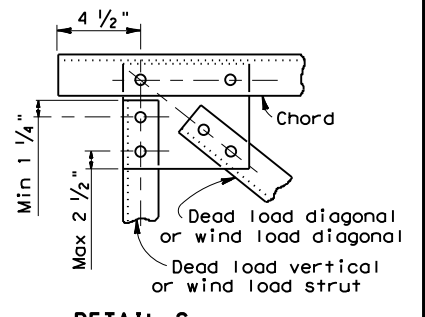

DETAIL G

NUMBER OF BOLTS REQD. IN GUSSET PLATE TO CHORD CONNECTION	
TOTAL NO. OF BOLTS IN DIAG'S. IN JOINT	
0	2
2	2
3	3
4	3
5	4
6	4
8	5
10	6

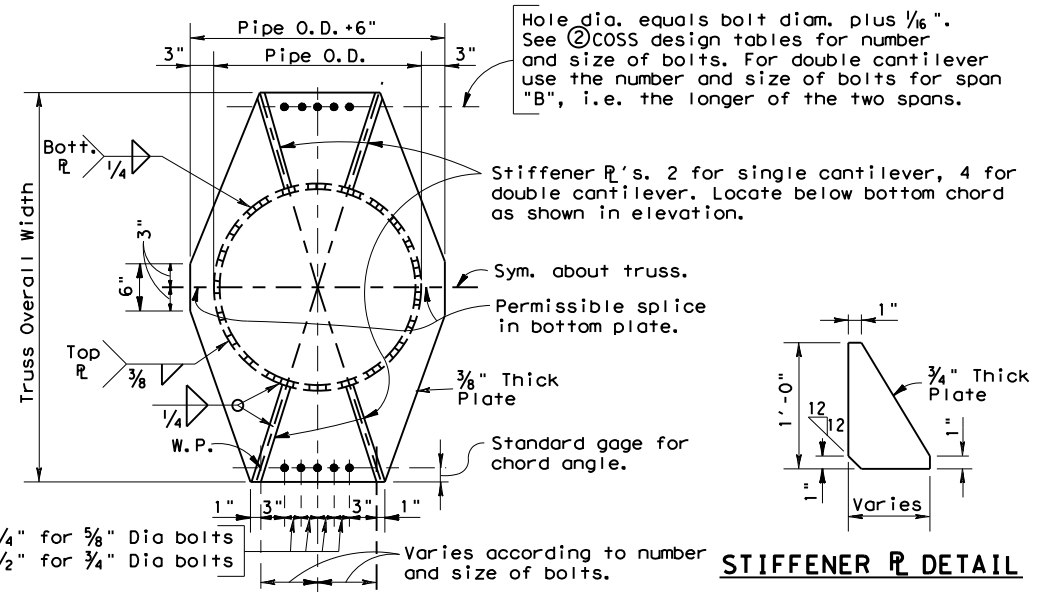

CONNECTION PLATE DETAIL

STIFFENER PLATE DETAIL

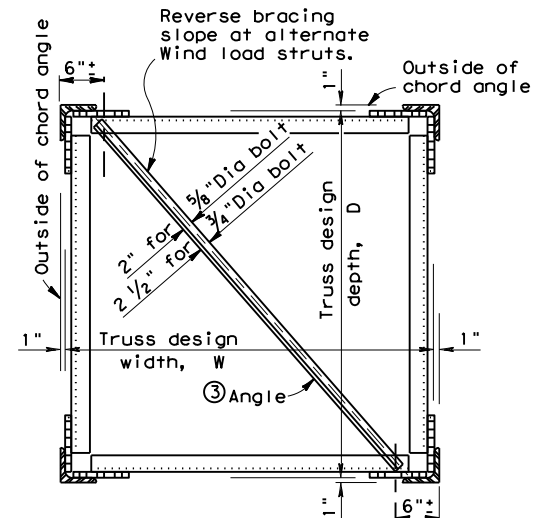

TRUSS SECTION

(DIAGONALS NOT SHOWN)

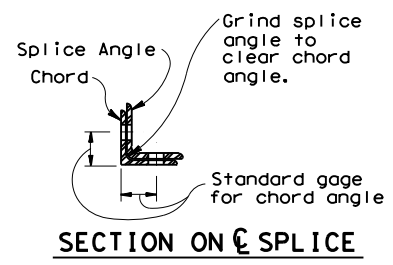

SECTION ON E SPLICE

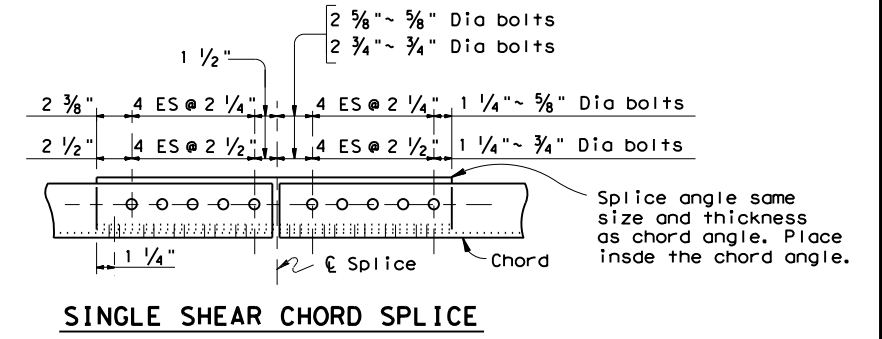

SINGLE SHEAR CHORD SPLICE

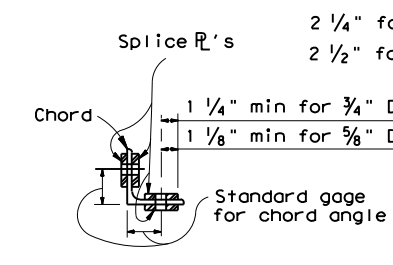

SECTION ON E SPLICE

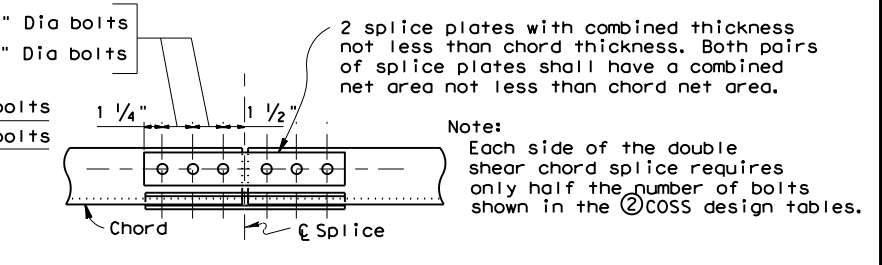

DOUBLE SHEAR CHORD SPLICE

SPLICE DETAILS

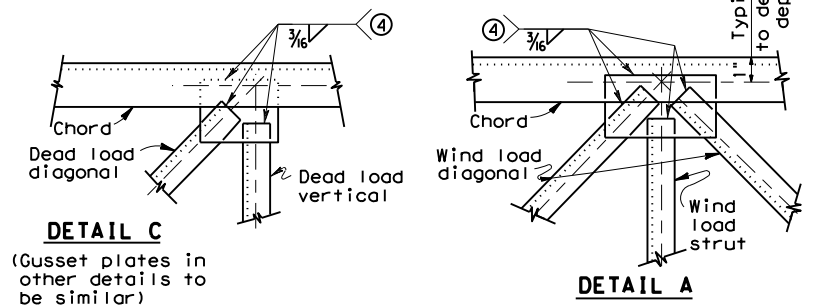

DETAIL C
(Gusset plates in other details to be similar)

DETAIL A

ALTERNATE WELDED CONNECTION DETAILS

④ MINIMUM LENGTH OF 3/16" FILLET WELD REQUIRED		
NUMBER OF BOLTS	TO REPLACE 5/8" DIA BOLTS	TO REPLACE 3/4" DIA BOLTS
1	2"	3"
2	4"	6"
3	6"	9"
4	8"	11 1/2"
5	10"	14 1/2"
6	12"	17 1/2"
7	14"	20"

CANTILEVER OVERHEAD SIGN SUPPORT DETAILS

COSSD

© TxDOT November 2007				
REVISIONS				
DN: TXDOT	CK: TXDOT	DW: TXDOT	CK: TXDOT	
CON: 0095	SECT: 14	JOB: 033, ETC	HIGHWAY: IH 20, ETC	
DIST: DAL	COUNTY: KAUFMAN, ETC	SHEET NO.:	298	

DISCLAIMER: The use of this standard is governed by the "Texas Engineering Practice Act". No warranty of any kind is made by TxDOT for any purpose whatsoever. TxDOT assumes no responsibility for the conversion of units or for the use of this standard in other formats or for incorrect results or damages resulting from its use.

DATE: 3/11/2023 4:32:19 PM
 FILE: T:\DAL\TRAFM\FY_2023_PS&E\I.H. 20" Pipe\Ion Set\Standards\non-paf_standards.dwg

Washers shall conform to ASTM F436.

ANCHOR BOLT DIA.	WASHER DIMENSIONS				HOLE IN BASE PLATE
	OUTSIDE DIAMETER	HOLE DIAMETER	THICKNESS		
			MIN.	MAX.	
d	2d	d + 1/8"	0.136"	0.177"	d + 1/4"
1 1/2" or less	2d	d + 1/8"	0.136"	0.177"	d + 1/4"
1 3/4"	2d - 1/8"	d + 1/8"	0.178"	0.280"	d + 5/16"
2"	2d - 1/4"	d + 1/8"	0.178"	0.280"	d + 5/16"
Over 2"	2d - 1/2"	d + 1/8"	0.240"	0.340"	d + 5/16"

ANCHOR BOLT SIZE				
DIA	BOLT LENGTH	THREAD LENGTH	PROJECTION LENGTH	GALVAN. LENGTH
1 1/4"	2'-11"	5"	5 1/4"	11 1/4"
1 3/8"	3'-1"	5 1/2"	5 3/4"	11 3/4"
1 1/2"	3'-4"	6"	6 1/4"	1'-0 1/4"
1 3/4"	3'-10"	7"	7 1/4"	1'-1 1/4"
2"	4'-3"	8"	8 1/4"	1'-2 1/4"
2 1/4"	4'-9"	9"	9 1/4"	1'-3 1/4"
2 1/2"	5'-2"	10"	10 1/4"	1'-4 1/4"
2 3/4"	5'-8"	11"	11 1/4"	1'-5 1/4"
3"	6'-1"	1'-0"	1'-0 1/4"	1'-6 1/4"

ANCHOR BOLT SIZE	PIPE OUTSIDE DIAMETER											
	16"			20"			24"			30"		
	BOLT CIRCLE DIA	DRILLED SHAFT SIZE	DRILLED SHAFT REINF	BOLT CIRCLE DIA	DRILLED SHAFT SIZE	DRILLED SHAFT REINF	BOLT CIRCLE DIA	DRILLED SHAFT SIZE	DRILLED SHAFT REINF	BOLT CIRCLE DIA	DRILLED SHAFT SIZE	DRILLED SHAFT REINF
1 1/4" Dia x 2'-11"	20 1/2"	36" Dia	14-#8 (A)	24 1/2"	36" Dia	14-#8 (A)						
1 3/8" Dia x 3'-1"	20 3/4"	36" Dia	12-#9 (A)	24 3/4"	42" Dia	14-#9 (A)						
1 1/2" Dia x 3'-4"	21"	36" Dia	12-#9 (A)	25"	42" Dia	14-#9 (A)	29"	42" Dia	14-#9 (C)			
1 3/4" Dia x 3'-10"	21 1/2"	36" Dia	10-#10 (A)	25 3/8"	42" Dia	12-#10 (B)	29 3/8"	48" Dia	16-#10 (C)	35 3/8"	54" Dia	18-#10 (C)
2" Dia x 4'-3"	22"	36" Dia	12-#10 (A)	25 3/4"	42" Dia	12-#10 (B)	29 3/4"	48" Dia	16-#10 (C)	35 3/4"	54" Dia	18-#10 (C)
2 1/4" Dia x 4'-9"	22 1/2"	42" Dia	12-#11 (A)	26"	42" Dia	10-#11 (B)	30"	48" Dia	14-#11 (C)	36"	54" Dia	14-#11 (D)
2 1/2" Dia x 5'-2"				26 1/2"	42" Dia	12-#11 (B)	30 1/2"	48" Dia	16-#11 (C)	36 1/2"	54" Dia	16-#11 (D)
2 3/4" Dia x 5'-8"							31 1/2"	48" Dia	18-#11 (D)	37"	54" Dia	20-#11 (D)
3" Dia x 6'-1"										37 1/2"	54" Dia	24-#11 (D)

- ① Anchor Bolt Fabrication Tolerances:
 Bolt Length ~ ±1/2"
 Thread Length ~ ±1/2"
 Galvanized Length ~ -1/4"
- ② Thread length applies to upper and lower threads

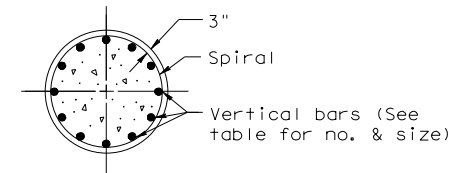

- A = #3 Plain spiral at 6" pitch (Grade 40)
- B = #4 Plain spiral at 6" pitch (Grade 40)
- C = #4 Plain spiral at 6" pitch (Grade 60)
- D = #4 Plain spiral at 3 1/2" pitch (Grade 60)

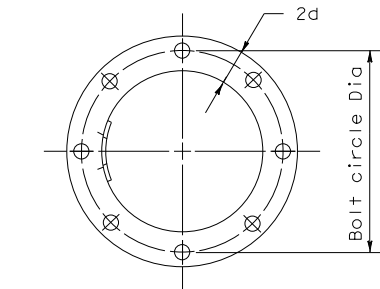
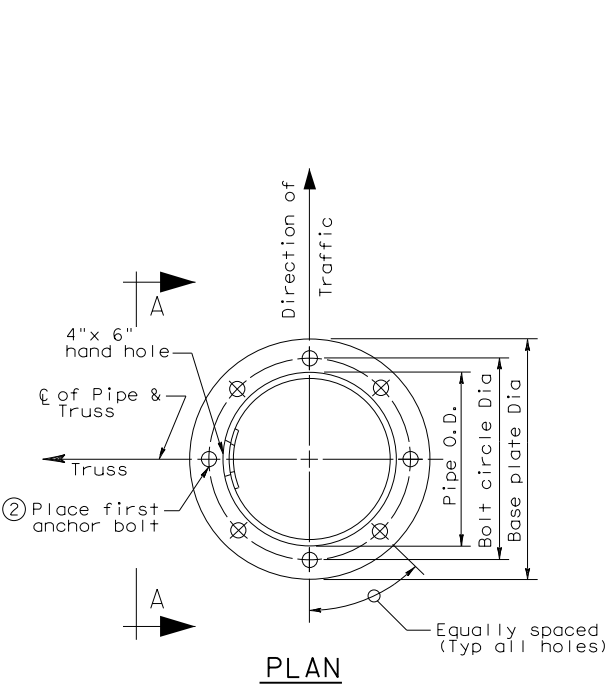

TOP VIEW OF TOP & BOTTOM TEMPLATES

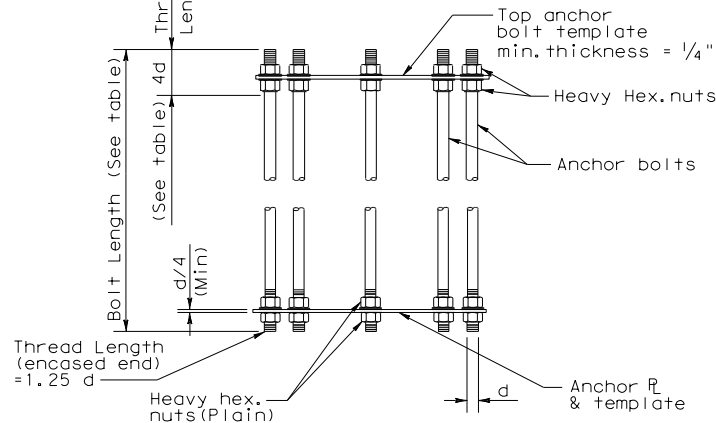

ANCHOR BOLT ASSEMBLY (PRIOR TO INSTALLATION)

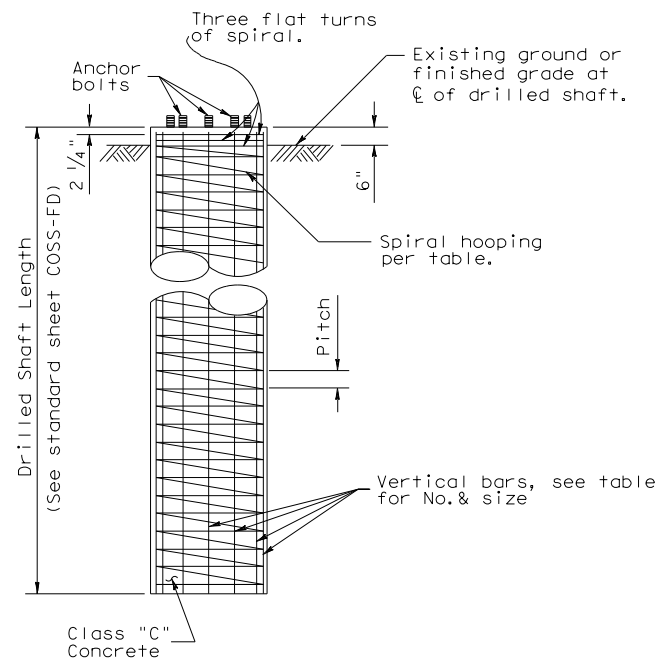

FOUNDATION DETAIL

GENERAL NOTES

1. Concrete shall be Class "C".
2. Reinforcing shall conform to Item 440, "Reinforcing Steel".
3. Anchor bolts and nuts for anchor bolts shall be "Alloy Steel" per Item 449, "Anchor Bolts".
4. Anchor bolts shall be rigidly held in position during concrete placement using steel templates at the top and bottom. The top templates shall be removed after the concrete has set.
5. Lubricate and tighten anchor bolts when erecting the structure per Item 449, "Anchor Bolts". After the structure has been aligned in its final position and the anchor bolts have been properly tightened, tack weld anchor bolt nuts to washer, and tack weld washers to base plate. Galvanizing in tack welded areas shall be repaired in accordance with Item 445, "Galvanizing".
6. All vertical reinforcing shall be carried to the bottom of the Drilled Shaft.

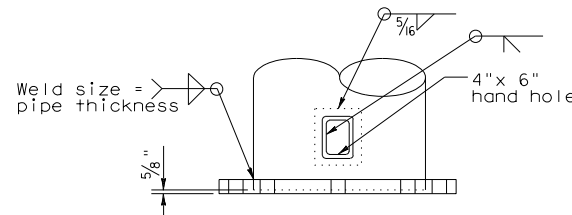

VIEW A-A

③ BASE PLATE & HANDHOLE DETAILS

- ③ See "Cantilever Overhead Sign Support" or "High Level Cantilever Overhead Sign Support" sheets for Diameter and thickness of base plate.

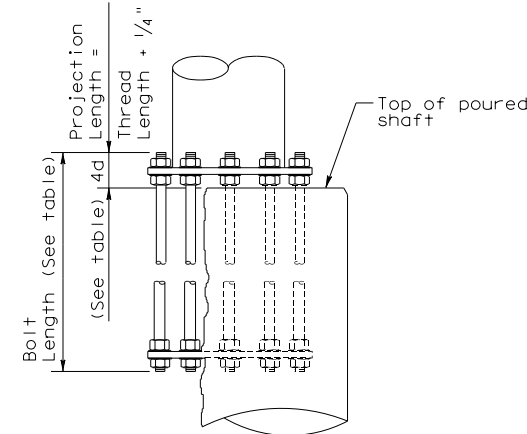

BEARING SEAT ELEVATION

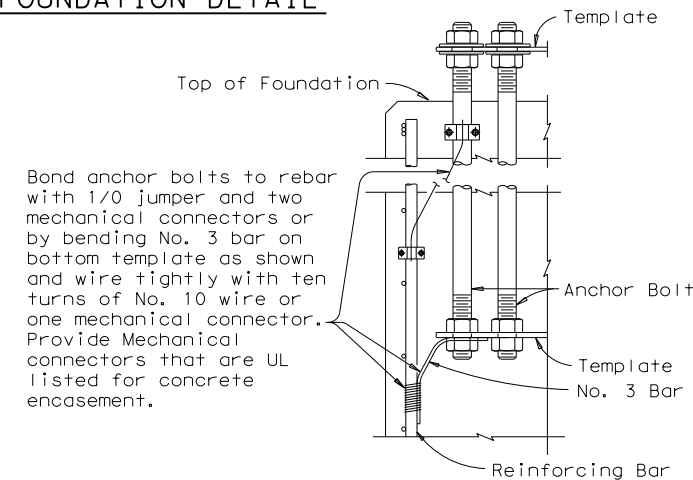

LIGHTNING PROTECTION SYSTEM

CANTILEVER OVERHEAD SIGN SUPPORT FOUNDATION			
COSSF-21			
FILE: cossf-21.dgn	DN:	CK:	DW:
© TxDOT November 2007	CONT SECT	JOB	HIGHWAY
8-21	REVISIONS	0095 14	033, ETC IH 20, ETC
	DIST	COUNTY	SHEET NO.
	DAL	KAUFMAN, ETC	299

DISCLAIMER: The use of this standard is governed by the "Texas Engineering Practice Act". No warranty of any kind is made by TxDOT for any purpose whatsoever. TxDOT assumes no responsibility for the conversion of this standard to other formats or for incorrect results or damages resulting from its use.

DATE: 3/1/2023 4:32:19 PM
 FILE: I:\DAL\TRAFFIC\2023 PS&E\I.H. 20\Plan Set\standards\non-paf_standards\300 COSS-FD.dgn

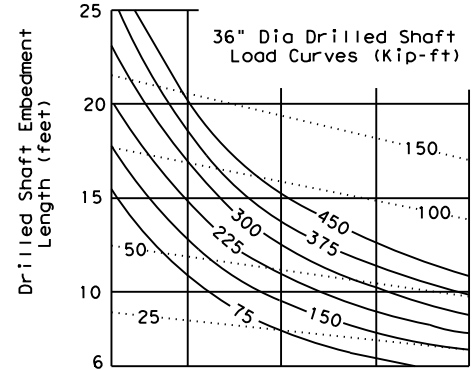

①	28.5°	30°	32°	34°	36°
②	12	21	35	50	65

- ① ϕ = Angle of internal friction of soil (degrees)
- ② N = Texas cone penetrometer value (blows per ft)
- ④ C(psi) = Cohesive shear strength of soil (psi)
- ⑤ C(psf) = Cohesive shear strength of soil (psf)

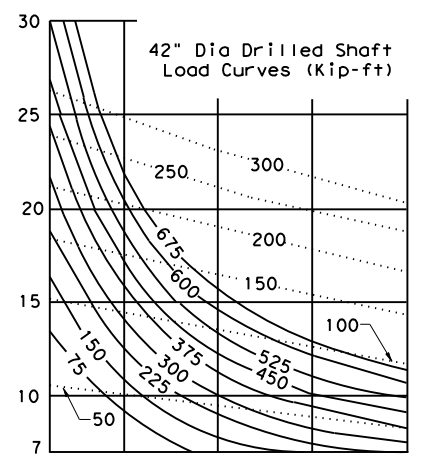

①	28.5°	30°	32°	34°	36°
②	12	21	35	50	65

③ SUBMERGED SAND SOIL (COHESIONLESS)

Moment —————
 Torsion ··········

③ Note:
 For unsubmerged sands and clayey sands the charts for clay soil will give a conservative foundation design.

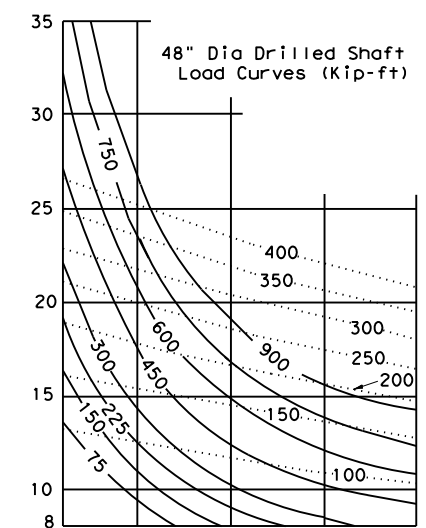

①	28.5°	30°	32°	34°	36°
②	12	21	35	50	65

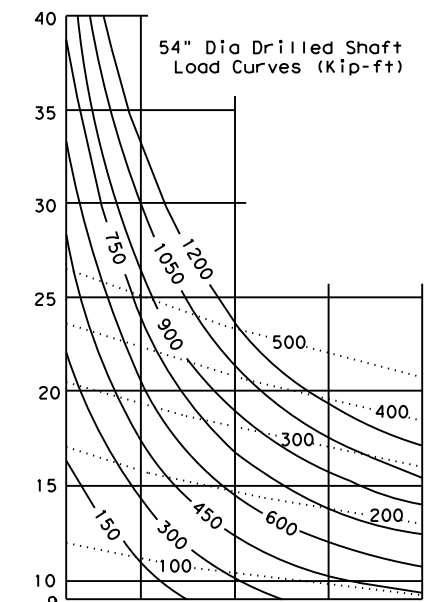

①	28.5°	30°	32°	34°	36°
②	12	21	35	50	65

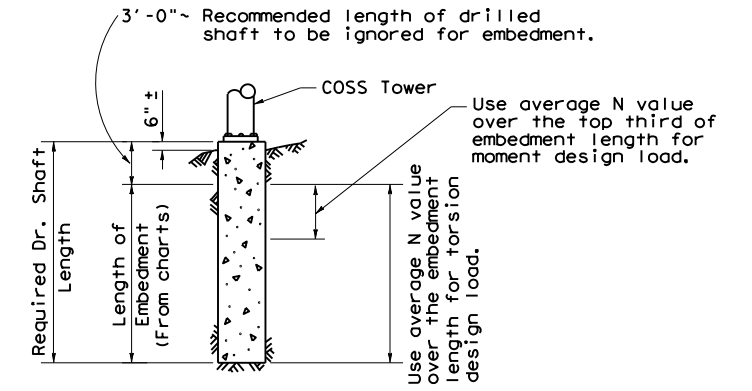

PROCEDURE:

1. Determine design moment and torsion, and the required drilled shaft diameter as outlined in the selection example sheet COSS-SE.
2. Make an initial estimate of the required embedment length.
3. From soil exploration data determine type of soil and average N value or soil property along the upper third of the drilled shaft.
4. Enter chart (for the correct shaft diameter and soil type) from the bottom at the average N value or soil property determined in step 3.
5. Proceed vertically into chart and locate intersection with design moment. Interpolate between moment curves (solid lines) as needed.
6. From intersection point turn 90° to left and read embedment length along vertical scale.
7. If embedment length differs significantly from estimated value return to step 3 with the embedment length determined in step 6.
8. From soil exploration data determine average N value or soil property over the entire length of the embedment.
9. Enter chart (for correct shaft diameter and soil type) from the bottom at the average N value or soil property determined in step 8.
10. Proceed vertically into chart and locate intersection with design torsion. Interpolate between torsion curves (dashed lines) as needed.
11. From intersection point turn 90° to left and read embedment length along vertical scale.
12. Compute the required length of drilled shaft by adding 3'-0" to longer embedment length required for moment or torsion.

GENERAL NOTES:

These charts are for use with Cantilever Overhead Sign Supports with one shaft per tower.
 Solid curves are base moment in Kip-ft.
 Dash curves are base torsion in Kip-ft.
 Minimum embedment of drilled shaft is two diameters.
 Add 3'-0" to the required embedment length to determine the required length of drilled shaft.

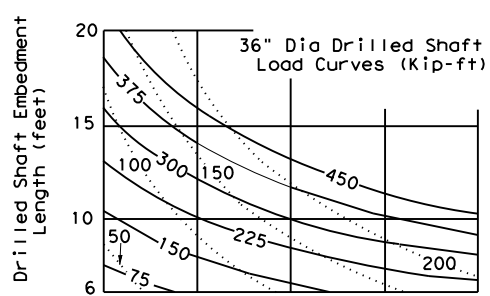

④	4	8	12	16	20
⑤	576	1152	1728	2304	2880
②	10	20	30	40	50

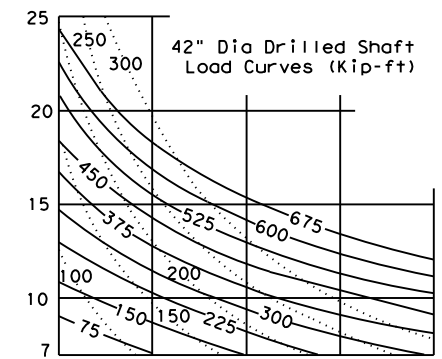

④	4	8	12	16	20
⑤	576	1152	1728	2304	2880
②	10	20	30	40	50

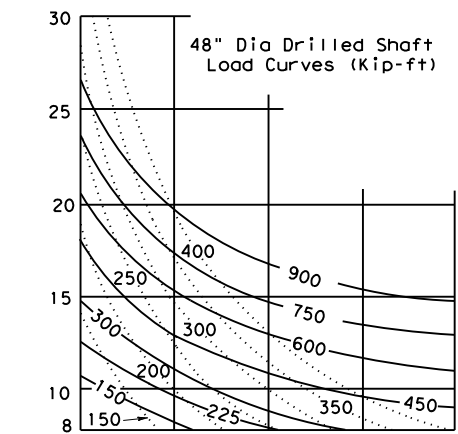

④	4	8	12	16	20
⑤	576	1152	1728	2304	2880
②	10	20	30	40	50

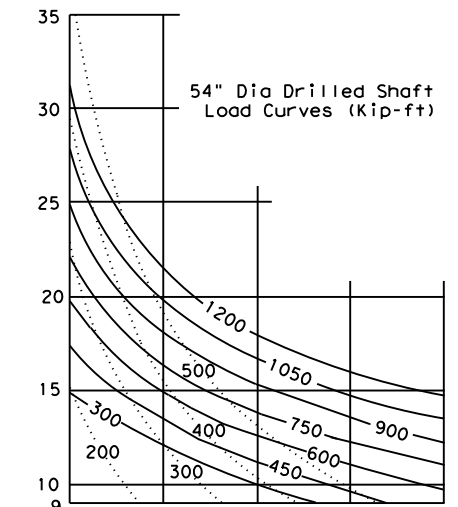

④	4	8	12	16	20
⑤	576	1152	1728	2304	2880
②	10	20	30	40	50

CLAY SOIL (COHESIVE)

Moment —————
 Torsion ··········

Texas Department of Transportation
 Traffic Operations Division

FOUNDATION EMBEDMENT SELECTION CHARTS

COSS-FD

© TxDOT November 2007		DN: TxDOT	CK: TxDOT	DW: TxDOT	CK: TxDOT
REVISIONS		CONT	SECT	JOB	HIGHWAY
		0095	14	033, ETC	IH 20, ETC
		DIST	COUNTY		SHEET NO.
		DAL	KAUFMAN, ETC		300

DISCLAIMER: The use of this standard is governed by the "Texas Engineering Practice Act". No warranty of any kind is made by TxDOT for any purpose whatsoever. TxDOT assumes no responsibility for the conversion of any information into any other format or for incorrect results or damages resulting from its use.

DATE: 3/1/2023 4:32:20 PM
 FILE: T:\DAL\TRAFFIC\2023 PS&E\I.H. 20\Plan Set\Standards\non-paf_standards\3011802_Support Brackets for Signs, Walkways and Lights.dwg

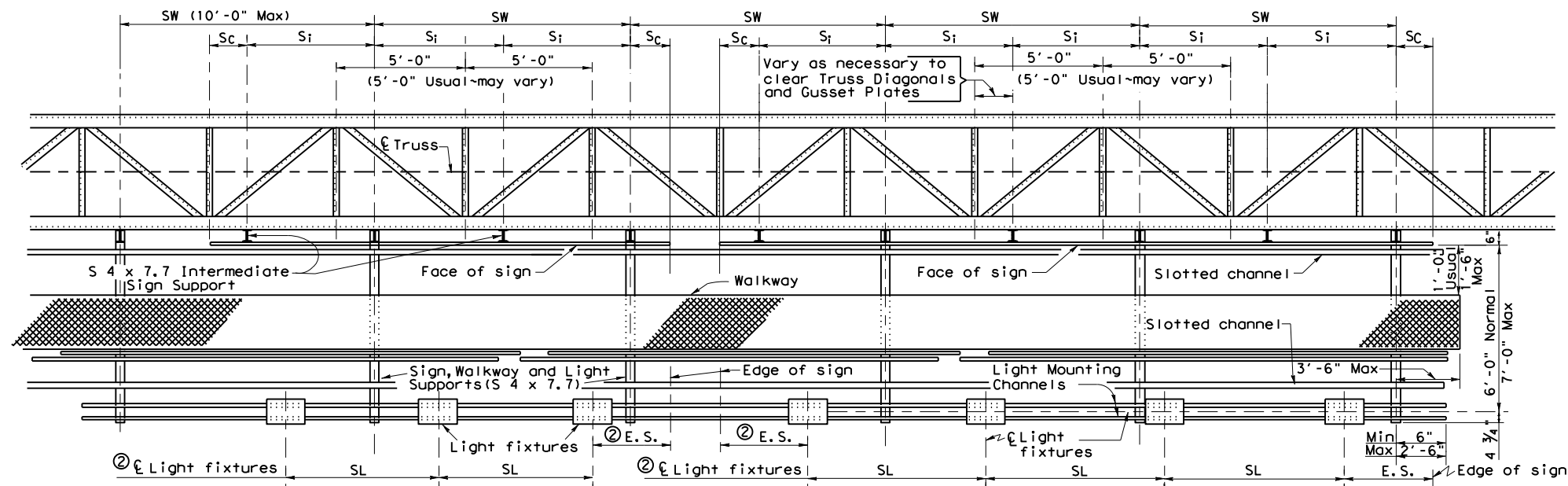

Sc=6" Min and .25 Si Max
 ② See SL(MV) for light fixture spacing.

PART PLAN
 (Showing Truss, Signs, Walkways and Lights)

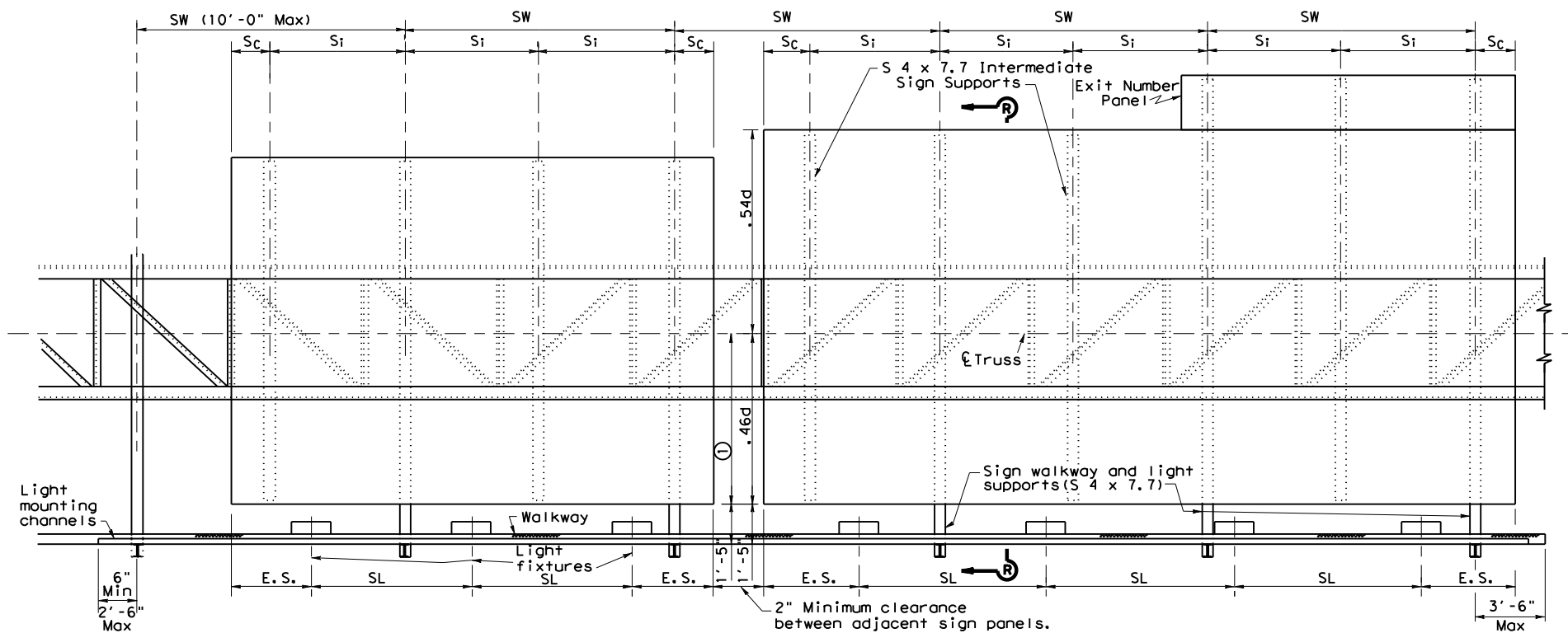

① Where signs of different depths are used, the bottom edge of all signs may be placed in line. Where this is done, all signs should be so positioned that the bottom edges are approximately 0.46 of the depth of the deepest sign below the ϵ of the truss. When signs are spaced thus, Si is determined by the deepest sign.

See sheet SL(MV) for Lighting Details & Spa.S.L. & E.S.
 See sheet SWW(1) for Walkway Details.
 See sheet SMD(2-4) for Extruded Aluminum Sign Details & Max. Spa. for Si.
 Sc= 6" min, .25 Si max.

PART ELEVATION

Note: Exit Number Panel may be supported by sign support brackets as shown hereon, or may be supported as shown on sheet SMD(2-4). Regardless of method used spacing of supports shall not exceed Si.

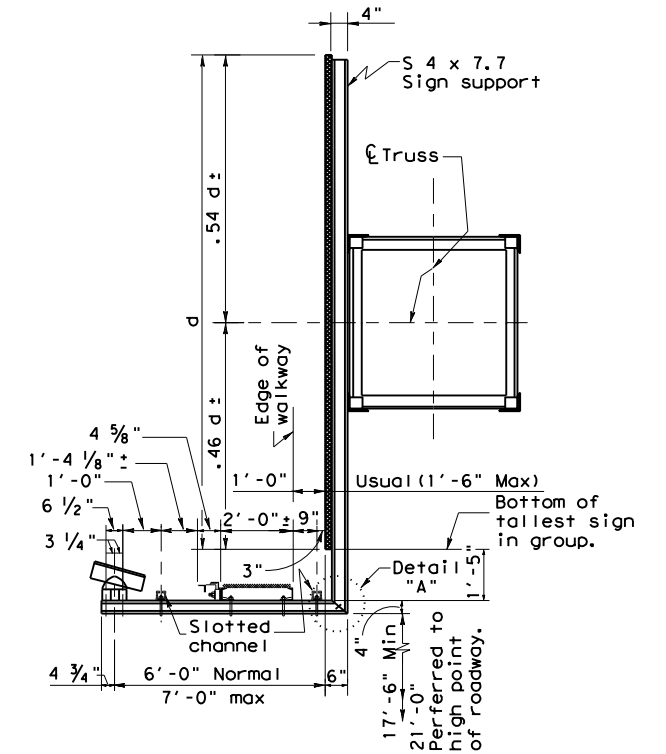

SECTION R-R

SHEET 1 OF 2

		Traffic Operations Division Standard	
SUPPORT BRACKETS FOR SIGNS, WALKWAYS & LIGHTS			
SB(SWL-1)-14			
FILE:	swl-14.dgn	DN:	TxDOT
© TxDOT	April 2014	CK:	TxDOT
REVISIONS	CONT	SECT	JOB
	0095	14	033, ETC
	DIST	COUNTY	HIGHWAY
	DAL	KAUFMAN, ETC	20, ETC
			SHEET NO.
			301

DISCLAIMER: The use of this standard is governed by the "Texas Engineering Practice Act". No warranty of any kind is made by TxDOT for any purpose whatsoever. TxDOT assumes no responsibility for the conversion of units or for the accuracy of the information provided or for incorrect results or damages resulting from its use.

DATE: 3/11/2023 4:32:21 PM
 FILE: T:\DAL\TRAFFIC\2023 PS&E\14 Set\Standard\Non-paf standard.dwg

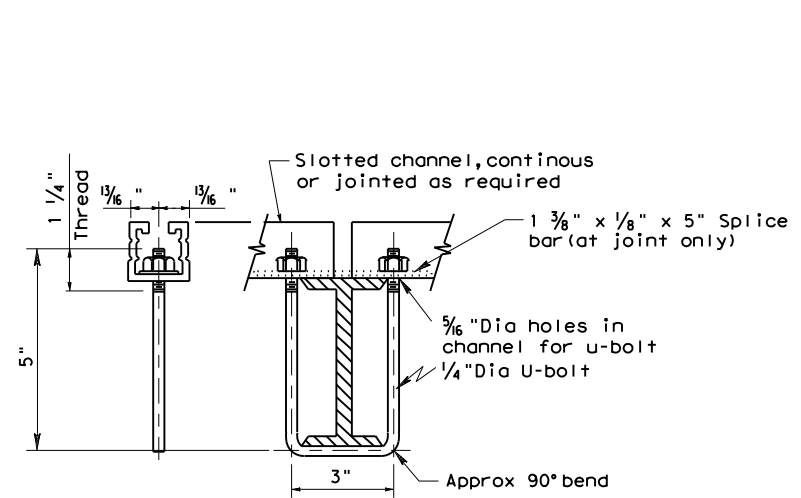

SECTION A-A

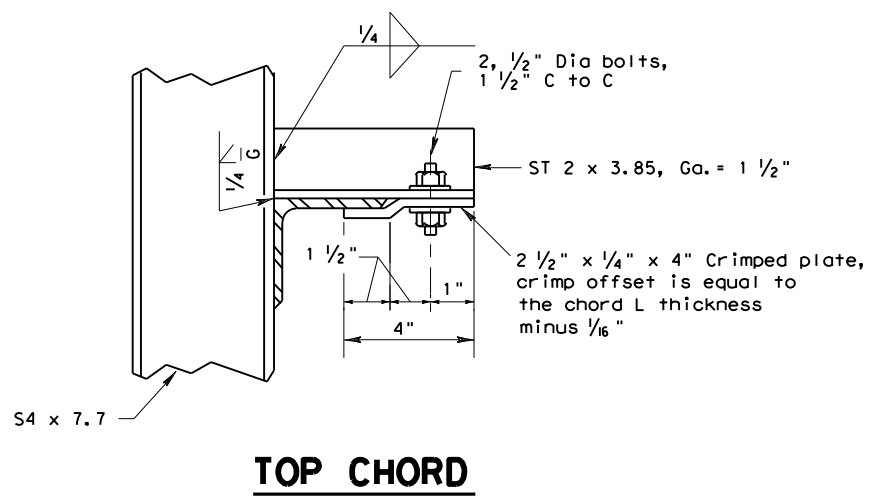

TOP CHORD

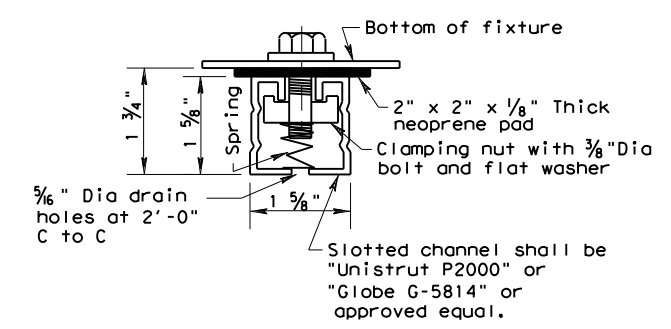

**TYPICAL SLOTTED CHANNEL
CONNECTED TO
LIGHTING FIXTURE**

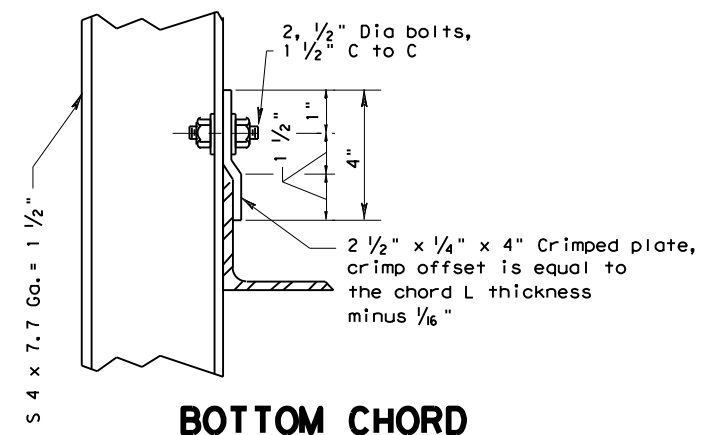

**BOTTOM CHORD
SUPPORT TO TRUSS
CONNECTION**

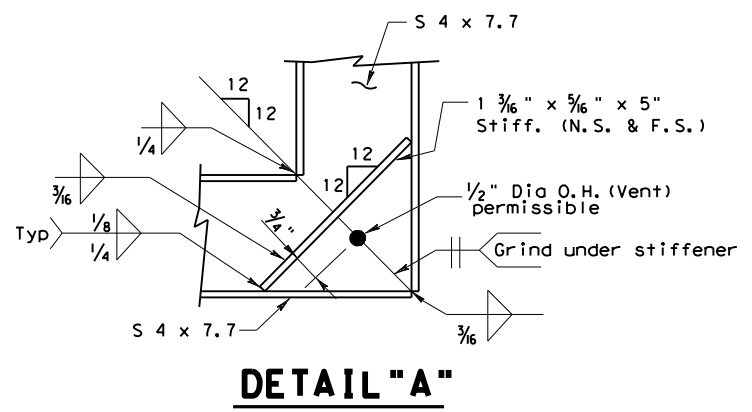

DETAIL "A"

GENERAL NOTES:
 Design conforms to 1994 AASHTO Standard Specifications for Structural Supports for Highway Signs, Luminaires and Traffic Signals and Interim revisions thereto.
 Materials, fabrication, construction and erection shall conform to Item 654, "Sign Walkways" and with details, dimensions, and weld procedures shown herein. Structural steel shall conform with ASTM A36 unless noted otherwise.
 Bolts shall have hexagon heads and nuts and conform with ASTM A307.
 All parts shall be galvanized after fabrication per Item 445, "Galvanizing".

SHEET 2 OF 2

		Traffic Operations Division Standard	
SUPPORT BRACKETS FOR SIGNS, WALKWAYS & LIGHTS			
SB(SWL-1)-14			
FILE: SWL-14.DGN	DN: TxDOT	CK: TxDOT	DW: TxDOT
© TxDOT April 2014	CONT	SECT	JOB
REVISIONS	0095 14	033, ETC	IH 20, ETC
DIST	COUNTY	SHEET NO.	
DAL	KAUFMAN, ETC	302	

Notes To Designer:

1. Do not alter Sheet Design or Font style, size or weight - match text attributes.
2. If additional space is needed for a numbered section, fence and adjust sections up or down as needed for proportioning and readability but do not relocate from its relative position.
3. All areas should be addressed thoroughly and verify the necessary pay items are set up to support actions needed.

DISCLAIMER:

The use of this standard is governed by the "Texas Engineering Practice Act". No warranty of any kind is made by TxDOT for any purpose whatsoever. TxDOT assumes no responsibility for the conversion of this standard to other formats or for incorrect results or damage resulting from its use.

Filled Out: XX/XX/XXXX
Prepared By: Name/Section

I. STORMWATER POLLUTION PREVENTION PLAN-CLEAN WATER ACT SECTION 402

TPDES TXR 150000: Stormwater Discharge Permit or Construction General Permit required for projects with 1 or more acres disturbed soil. Projects with any disturbed soil must protect for erosion and sedimentation in accordance with Item 506.

List adjacent MS 4 Operator(s) that receive discharges from this project. They need to be notified prior to construction activities.
(Note: Leave blank only if no adjacent MS 4 Operator(s) are affected.)

1. City of Dallas Phase I MS4 contact Kevin Hurley
2. City of Mesquite Phase I MS4 contact Corey Nesbit, City Engineer
3. City of Balch Springs Phase II MS4 contact William Freeman
4. City of Duncanville Phase II MS4 contact Greg Ramey, Public Works Director
5. City of Grand Prairie Phase II MS4 contact City Mendez, Water Quality Manager
6. City of Hutchins Phase II MS4 contact Scott Metcalf, Director of Utilities

No Action Required Required Action

Action Number:

1. Prevent stormwater pollution by controlling erosion and sedimentation in accordance with TPDES Permit TXR 150000.
2. Comply with the SW3P and revise when necessary to control pollution or required by the Engineer.
3. Post Construction Site Notice (CSN) with SW3P information on or near the site, accessible to the public and TCEQ, EPA or other inspectors.
4. When Contractor project specific locations (PSL's) increase disturbed soil area to 5 acres or more, submit NOI to TCEQ and the Engineer.

II. WORK IN OR NEAR STREAMS, WATERBODIES AND WETLANDS CLEAN WATER ACT SECTIONS 401 AND 404

USACE Permit required for filling, dredging, excavating or other work in any water bodies, rivers, creeks, streams, wetlands or wet areas. No equipment is allowed in any stream channel below the ordinary High Water Mark except on approved temporary stream crossings or drill pads.

The Contractor must adhere to all of the terms and conditions associated with the following permit(s):

- No Permit Required
- Nationwide Permit 14 - PCN not Required (less than 1/10th acre waters or wetlands affected)
- Nationwide Permit 14 - PCN Required (1/10 to <1/2 acre, 1/3 in tidal waters)
- Individual 404 Permit Required
- Other Nationwide Permit Required: NWP# 3(a)

Required Actions: List Waters of the US Permit applies to, location in project and check Best Management Practices planned to control erosion, sedimentation and post-project TSS.

- 1.
- 2.
- 3.

The elevation of the ordinary high water marks of any areas requiring work to be performed in the waters of the US requiring the use of a nationwide permit can be found on the Bridge Layouts.

Best Management Practices for applicable 401 General Conditions:
(Note: If CORP Permit not required, do not check boxes.)

Erosion	Sedimentation	Post-Construction TSS
<input type="checkbox"/> Temporary Vegetation	<input type="checkbox"/> Silt Fence	<input type="checkbox"/> Vegetative Filter Strips
<input type="checkbox"/> Blankets/Matting	<input type="checkbox"/> Rock Berm	<input type="checkbox"/> Retention/Irrigation Systems
<input type="checkbox"/> Mulch	<input type="checkbox"/> Triangular Filter Dike	<input type="checkbox"/> Extended Detention Basin
<input type="checkbox"/> Sodding	<input type="checkbox"/> Sand Bag Berm	<input type="checkbox"/> Constructed Wetlands
<input type="checkbox"/> Interceptor Swale	<input type="checkbox"/> Straw Bale Dike	<input type="checkbox"/> Wet Basin
<input type="checkbox"/> Diversion Dike	<input type="checkbox"/> Brush Berms	<input type="checkbox"/> Erosion Control Compost
<input type="checkbox"/> Erosion Control Compost	<input type="checkbox"/> Erosion Control Compost	<input type="checkbox"/> Mulch Filter Berm and Socks
<input type="checkbox"/> Mulch Filter Berm and Socks	<input type="checkbox"/> Mulch Filter Berm and Socks	<input type="checkbox"/> Compost Filter Berm and Socks
<input type="checkbox"/> Compost Filter Berm and Socks	<input type="checkbox"/> Compost Filter Berm and Socks	<input type="checkbox"/> Vegetation Lined Ditches
	<input type="checkbox"/> Stone Outlet Sediment Traps	<input type="checkbox"/> Sand Filter Systems
	<input type="checkbox"/> Sediment Basins	<input type="checkbox"/> Grassy Swales

III. CULTURAL RESOURCES

Refer to TxDOT Standard Specifications in the event historical issues or archeological artifacts are found during construction. Upon discovery of archeological artifacts (bones, burnt rock, flint, pottery, etc.) cease work in the immediate area and contact the Engineer immediately.

No Action Required Required Action

Action Number:

- 1.
- 2.
- 3.

IV. VEGETATION RESOURCES

Preserve native vegetation to the extent practical. Contractor must adhere to Construction Specification Requirements Specs 162, 164, 192, 193, 506, 730, 751 & 752 in order to comply with requirements for invasive species, beneficial landscaping and tree/brush removal commitments.

No Action Required Required Action

Action Number:

- 1.
- 2.
- 3.

V. FEDERAL LISTED, PROPOSED THREATENED, ENDANGERED SPECIES, CRITICAL HABITAT, STATE LISTED SPECIES, CANDIDATE SPECIES AND MIGRATORY BIRDS TREATY ACT.

No Action Required Required Action

Action Number:

1. Follow Special Notes.

Special Notes:

1. Avoid harming all wildlife species if encountered and allow them to safely leave the project site. Due diligence should be used to avoid killing or harming any wildlife species in the implementation of transportation projects.
2. If any of the listed species are observed, cease work in the immediate area, do not disturb species or habitat and contact the Engineer immediately. The work may not remove active nests from bridges and other structures during nesting season of the birds associated with the nests. If caves or sinkholes are discovered, cease work in the immediated area, and contact the Engineer immediately.
3. The Migratory Bird Act of 1918 states that it is unlawful to kill, capture, collect, possess, buy, sell, trade or transport any migratory bird, nest, young, feather or egg in part or in whole, without a federal permit issued in accordance within the Act's policies and regulations. The contractor would remove all old migratory bird nests from any structure or trees where work would be done from October 1 to February 15. In addition, the contractor would be prepared to prevent migratory birds from building nest(s) between February 15 to October 1. In the event that migratory birds are encountered on-site during project construction, efforts to avoid adverse impacts on protected birds, active nests, eggs and/or young would be observed.

LIST OF ABBREVIATIONS

BMP: Best Management Practice	SPCC: Spill Prevention Control and Countermeasure
CGP: Construction General Permit	SW3P: Storm Water Pollution Prevention Plan
DSHS: Texas Department of State Health Services	PCN: Pre-Construction Notification
FHWA: Federal Highway Administration	PSL: Project Specific Location
MOA: Memorandum of Agreement	TCEQ: Texas Commission on Environmental Quality
MOU: Memorandum of Understanding	TPDES: Texas Pollutant Discharge Elimination System
MS4: Municipal Separate Stormwater Sewer System	TPWD: Texas Parks and Wildlife Department
MBTA: Migratory Bird Treaty Act	TxDOT: Texas Department of Transportation
NOT: Notice of Termination	T&E: Threatened and Endangered Species
NWP: Nationwide Permit	USACE: U.S. Army Corp of Engineers
NOI: Notice of Intent	USFWS: U.S. Fish and Wildlife Service

VI. HAZARDOUS MATERIALS OR CONTAMINATION ISSUES

General (applies to all projects):

Comply with the Hazard Communication Act (the Act) for personnel who will be working with hazardous materials by conducting safety meetings prior to beginning construction and making workers aware of potential hazards in the workplace. Ensure that all workers are provided with personal protective equipment appropriate for any hazardous materials used. Obtain and keep on-site Safety Data Sheets (SDS) for all hazardous products used on the project, which may include, but are not limited to the following categories: Paints, acids, solvents, asphalt products, chemical additives, fuels and concrete curing compounds or additives. Provide protected storage, off bare ground and covered, for products which may be hazardous. Maintain product labelling as required by the Act. Maintain an adequate supply of on-site spill response materials, as indicated in the SDS. In the event of a spill, take actions to mitigate the spill as indicated in the SDS, in accordance with safe work practices, and contact the District Spill Coordinator immediately. The Contractor shall be responsible for the proper containment and cleanup of all product spills.

Contact the Engineer if any of the following are detected:

- * Dead or distressed vegetation (not identified as normal)
- * Trash piles, drums, canisters, barrels, etc.
- * Undesirable smells or odors
- * Evidence of leaching or seepage of substances

Does the project involve any bridge class structure rehabilitation(s) or replacement(s) (bridge class structures not including box culverts)?

Yes No

If "No", then no further action is required.

If "Yes", then TxDOT is responsible for completing asbestos assessment/inspection.

Are the results of the asbestos inspection positive (is asbestos present)?

Yes No

If "Yes", then TxDOT must retain a DSHS licensed asbestos consultant to assist with the notification, develop abatement/mitigation procedures, and perform management activities as necessary. The notification form to DSHS must be postmarked at least 15 working days prior to scheduled demolition.

If "No", then TxDOT is still required to notify DSHS 15 working days prior to any scheduled demolition.

In either case, the Contractor is responsible for providing the date(s) for abatement activities and/or demolition with careful coordination between the Engineer and asbestos consultant in order to minimize construction delays and subsequent claims.

Any other evidence indicating possible hazardous materials or contamination discovered on site. Hazardous Materials or Contamination Issues Specific to this Project:

No Action Required Required Action

Action Number:

- 1.
- 2.
- 3.

VII. OTHER ENVIRONMENTAL ISSUES

(includes regional issues such as Edwards Aquifer District, etc.)

No Action Required Required Action

Action Number:

- 1.

GENERAL NOTE:

Any change orders and/or deviations from the final design must be reported to the Engineer prior to commencement of construction activities, as additional environmental clearance may be required.



ENVIRONMENTAL PERMITS, ISSUES AND COMMITMENTS (EPIC)

FED. RD. DIV. NO.	FEDERAL AID PROJECT NO.		HIGHWAY NO.
6	SEE TITLE SHEET		IH 20, IH 635
STATE	DISTRICT	COUNTY	SHEET NO.
TEXAS	DALLAS	Dallas, Kaufman	
CONTROL	SECTION	JOB	SHEET NO.
0095	14	033, etc.	

A. GENERAL SITE DATA

1. **PROJECT LIMITS:** (Same as stated on the Title Sheet)

Begin Project Coordinates : Latitude (N) : XX.XXXXX Longitude (W) : -XX.XXXXX
 (Latitude & Longitude - Go to <http://www.latlong.net/> or Google Earth for coordinates)

2. **PROJECT SITE MAPS:**

- * Project Location Map: The Title Sheet
- * Drainage Patterns: Drainage Area Maps (Sheets X-Y)
- * Slopes Anticipated After Major Gradients or Areas of Soil Disturbance: Typical Sections (Sheets X-Y)
- * Location of Erosion and Sediment Controls: SW3P Site Maps (Sheets X-Y)
- * Surface Waters and Discharge Locations: Drainage and Culvert Layouts (Sheets X-Y)
- * Project Specific Location(s) (PSL): To be determined by the project Construction Personnel. Location(s) shown on SW3P Site Map (if PSL location(s) is within one mile of project) and information located in project SW3P Binder (Reference Item *10 below).

3. **PROJECT DESCRIPTION:**

(Same description as stated on Title Sheet)

4. **MAJOR SOIL DISTURBING ACTIVITIES:**

(Provide description of disturbing activities in sequence of construction)

5. **EXISTING CONDITION OF SOIL & VEGETATIVE COVER AND % OF EXISTING VEGETATIVE COVER:**

(Provide description of soil types, condition, vegetative cover and percentage)

6. **TOTAL PROJECT AREA:** XXX.XX Acres

7. **TOTAL AREA TO BE DISTURBED:** XXX.XX Acres (XX %)

8. **WEIGHTED RUNOFF COEFFICIENT**

BEFORE CONSTRUCTION: X.XX
 AFTER CONSTRUCTION: X.XX

9. **NAME OF RECEIVING WATERS:**

(Provide description of receiving waters)
 (Provide Segment Numbers)

10. **PROJECT SW3P Binder:**

- A. For projects disturbing one to five acres, TxDOT will maintain a SW3P Binder at the project field office (if there is not a project field office, should be kept at the Area Office) which contains the following: Index Sheet, TCEQ Signature Authority, TxDOT's and Contractor's Small Construction Site Notice, SW3P Inspector Qualification Statements, EPIC Sheet, SW3P Sheet, Site Location Maps, Inspection and Maintenance Reports (Form 2118), Construction Stage Gate Checklists (CSGC), Stored Material Lists specifying associated control measures and the Appendix which contains the TPDES Construction General Permit, TxDOT and Contractor MS4 Operator Notification(s) and the Construction PSL Permits per all applicable requirements.
- B. For projects disturbing 5 acres or more, TxDOT will follow the actions listed in (10.A.) above with the addition of the following: TxDOT and Contractor Notice Of Intent (N.O.I.) and Fee Payment Form, TxDOT and Contractor Large Construction Site Notice (to be used instead of Small Site Notice), and TPDES Permit Coverage Notice.
- C. For projects disturbing less than one acre, actions described in (10.A.) and (10.B.) above are not required. Acreage is calculated by adding Total Area To Be Disturbed Acres on project (See *7 above) and the PSL(s) acreage located within one mile of project.

B. EROSION AND SEDIMENT CONTROLS

1. **SOIL STABILIZATION PRACTICES:** (Select T = Temporary or P = Permanent, as applicable)

- | | |
|--|--|
| <input type="checkbox"/> TEMPORARY SEEDING | <input type="checkbox"/> PRESERVATION OF NATURAL RESOURCES |
| <input type="checkbox"/> MULCHING (Hay or Straw) | <input type="checkbox"/> FLEXIBLE CHANNEL LINER |
| <input type="checkbox"/> BUFFER ZONES | <input type="checkbox"/> RIGID CHANNEL LINER |
| <input type="checkbox"/> PLANTING | <input type="checkbox"/> SOIL RETENTION BLANKET |
| <input type="checkbox"/> SEEDING | <input type="checkbox"/> COMPOST MANUFACTURED TOPSOIL |
| <input type="checkbox"/> SODDING | <input type="checkbox"/> VERTICAL TRACKING |
| | <input type="checkbox"/> OTHER: (Specify Practice) |

2. **STRUCTURAL PRACTICES:** (Select T = Temporary or P = Permanent, as applicable)

- SILT FENCES
- EROSION CONTROL LOGS
- EROSION CONTROL COMPOST BERMS (Low Velocity)
- ROCK FILTER DAMS
- DIVERSION, INTERCEPTOR, OR PERIMETER DIKES
- DIVERSION, INTERCEPTOR, OR PERIMETER SWALES
- DIVERSION DIKE AND SWALE COMBINATIONS
- PIPE SLOPE DRAINS
- PAVED FLUMES
- ROCK BEDDING AT CONSTRUCTION EXIT
- TIMBER MATTING AT CONSTRUCTION EXIT
- CHANNEL LINERS
- SEDIMENT TRAPS
- SEDIMENT BASINS
- STORM INLET SEDIMENT TRAP
- STONE OUTLET STRUCTURES
- CURBS AND GUTTERS
- STORM SEWERS
- VELOCITY CONTROL DEVICES
- OTHER: (Specify Practice)

NOTE: TOP OF BMP'S SHOULD NOT BE HIGHER THAN ROADWAY ELEVATION AS NOT TO FLOOD ROADWAY UNLESS PRIOR APPROVAL FROM ENGINEER IS OBTAINED.

3. **STORM WATER MANAGEMENT:** (Example Below - May be used as applicable, or revised)

- A. Storm water drainage will be provided by ditches, inlets, and storm water systems which carry drainage within the R.O.W. to the lows within the roadway and project site which drains to natural facilities.
- B. Other permanent erosion controls include hydraulic design to limit structure outlet velocities and grading design generally consisting of 4:1 or flatter slopes with permanent vegetative cover.

4. **STORM WATER MANAGEMENT ACTIVITIES:** (Sequence of Construction)

Designer: Describe Storm Water Management Activities by Phases. For projects that have a common drainage location that serves an area that will have ten (10) or more acres disturbed at one time, provide for storm water retention ponds, where feasible. If retention ponds cannot be provided, state reasons why they cannot be provided.

Instructions To Designer:

DO NOT ALTER SHEET DESIGN OR FONT STYLE, SIZE, OR WEIGHT - MATCH TEXT ATTRIBUTES.

If additional space is needed for a numbered item, fence and adjust item(s) up or down as needed for proportioning and readability but do not relocate from its relative position or section. Only GREEN notations may be revised, selected, or deleted by the designer. Designer to provide information requested by the RED instructional notes. Delete instructional notes before printing.

5. **NON-STORM WATER DISCHARGES:**

Filter non-storm water discharges, or hold in retention basins, before being allowed to mix with storm water. These discharges consist of, but not limited to, non-polluted ground water, spring water, foundation or footing drain water, water used for dust control or pavement washing and vehicle washwater containing no detergents.

C. OTHER REQUIREMENTS & PRACTICES

1. **MAINTENANCE:**

Maintain all erosion and sediment controls in good working order. Perform any necessary cleaning/repairs/replacements at the earliest possible date prior to next rain event, but no later than 7 calendar days. Ensure the surrounding ground has dried sufficiently to prevent damage from equipment. "Too Wet" is the only reason for not adhering to timeframes described. When construction activities permanently or temporarily cease and are not expected to resume for 14 or more days on a disturbed portion of the site, stabilization measures must be initiated immediately.

2. **INSPECTION:**

A TxDOT Inspector will perform a regularly scheduled SW3P Inspection every 7 calendar days. An Inspection and Maintenance Report, signed by the TxDOT Inspector and the Contractor, will be filed for each inspection. Revise/clean/repair/replace each BMP control device in accordance with the current Field Inspection and Maintenance Report (Form 2118) and Item 1 (Maintenance) above.

3. **WASTE MATERIALS:**

On a daily basis, or as may be directed, collect all waste materials, trash and debris from the construction site and deposit into a metal dumpster having a secure cover and which meets all state and local city solid waste management requirements. Empty the dumpster as required by regulation, or as may be directed, at a local approved landfill site. Do not bury construction waste on the construction project site.

4. **HAZARDOUS WASTE & SPILL REPORTING:**

As a minimum, any products in the following categories are considered to be hazardous: Paints, Acids, Solvents, Fuels, Asphalt Products, Chemical Additives for Soil Stabilization, and Concrete Curing Compounds or Additives. When storing hazardous material on the project site, or at a Project Specific Location, take all practicable precaution to prevent and/or contain any spillage of these materials. In the event of a spill, contact the spill coordinator immediately.

5. **SANITARY WASTE:**

Use a licensed sanitary waste management contractor to collect all sanitary waste from portable units as may be required by local regulation, or as directed.

6. **CONSTRUCTION VEHICLE TRACKING:**

On a regular basis, or as may be directed, dampen haul roads for dust control and construct construction entrances/exits. Provide for a motorized broom or vacuum type sweeper to be available on a daily basis, or as may be directed, to remove sediment from paved roadways on project, abutting and traversing the project site.

7. **MANAGEMENT PRACTICES:**

- A. Construct disposal areas, stockpiles, haul roads and PSL's in a manner that will minimize and control the amount of sediment that may enter receiving waters. Do not locate disposal areas in any wetland, waterbody or streambed.
- B. Locate construction staging areas, vehicle maintenance and PSL's areas in a manner to minimize the runoff of pollutants.
- C. When working in or near a wetland, install and maintain operating soil erosion and sediment controls at all times during construction and isolate the work from the wetland.
- D. Clear all waterways as soon as practicable of temporary embankment, temporary bridges, matting, falsework, piling, debris or other obstructions placed during construction operations that are not a part of the finished work.
- E. Procedures and/or practices should be taken to control dust.
- F. Sediment to be removed from roadways daily or when work begins after weather events if construction activities have ceased due to weather event.

DATE _____ DESIGNER _____

FILE NAME _____

DATE _____

DESIGNER _____

Design Consultant Logo here - delete block if not applicable



DALLAS DISTRICT ENVIRONMENTAL

STORM WATER POLLUTION PREVENTION PLAN (SW3P)

TEMPLATE REVISION DATE: 02/07/18

DESIGN	FED. RD. DIV. NO.	FEDERAL AID PROJECT NO.		HIGHWAY NO.
BLS	6	(SEE TITLE SHEET)		IH0020
GRAPHICS	MA	STATE	DISTRICT	COUNTY
CHECK	BA	TEXAS	DALLAS	DALLAS
CHECK	BB	CONTROL	SECTION	JOB
		0095	14	033, ETC

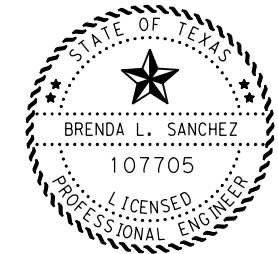

_____, P.E.
Signature of Registrant & Date