

**INDEX OF SHEETS**

SEE SHEET 2

**STATE OF TEXAS  
DEPARTMENT OF TRANSPORTATION**

**PLANS OF PROPOSED  
STATE HIGHWAY IMPROVEMENT**

STATE PROJECT NO. C 916 -28 -71

**GOOSE ISLAND  
STATE PARK  
ARANSAS COUNTY**

**LAKE CORPUS CHRISTI  
STATE PARK  
SAN PATRICIO COUNTY**

NET LENGTH OF ROADWAY= 8183 FT. = 1.550 MI.  
NET LENGTH OF PROJECT= 8183 FT. = 1.550 MI.

NET LENGTH OF ROADWAY= 22,357 FT. = 4.23 MI.  
NET LENGTH OF PROJECT= 26,400 FT. = 5.00 MI.

**LIMITS:**

FOR THE REHABILITATION OF ROADWAYS AND PARKING LOTS AT GOOSE ISLAND STATE PARK. CONSISTING OF: BASE REPAIR, SEAL COAT ROADWAY, PARKING LOTS AND CAMPSITE PULLOUTS.

**LIMITS:**

FOR THE REHABILITATION OF ROADWAYS AND PARKING LOTS LOCATED AT CORPUS CHRISTI STATE PARK. CONSISTING OF: BASE REPAIR, SEAL COAT ROADWAY, PARKING LOTS AND CAMPSITE PULLOUTS.

GOOSE ISLAND STATE PARK ENTRANCE  
CSJ: 0916-38-012  
REF MRK: 588+0.383

GOOSE ISLAND STATE PARK-ROCKPORT ANNEX  
CSJ: 0916-38-011  
REF MRK: 664+0.929

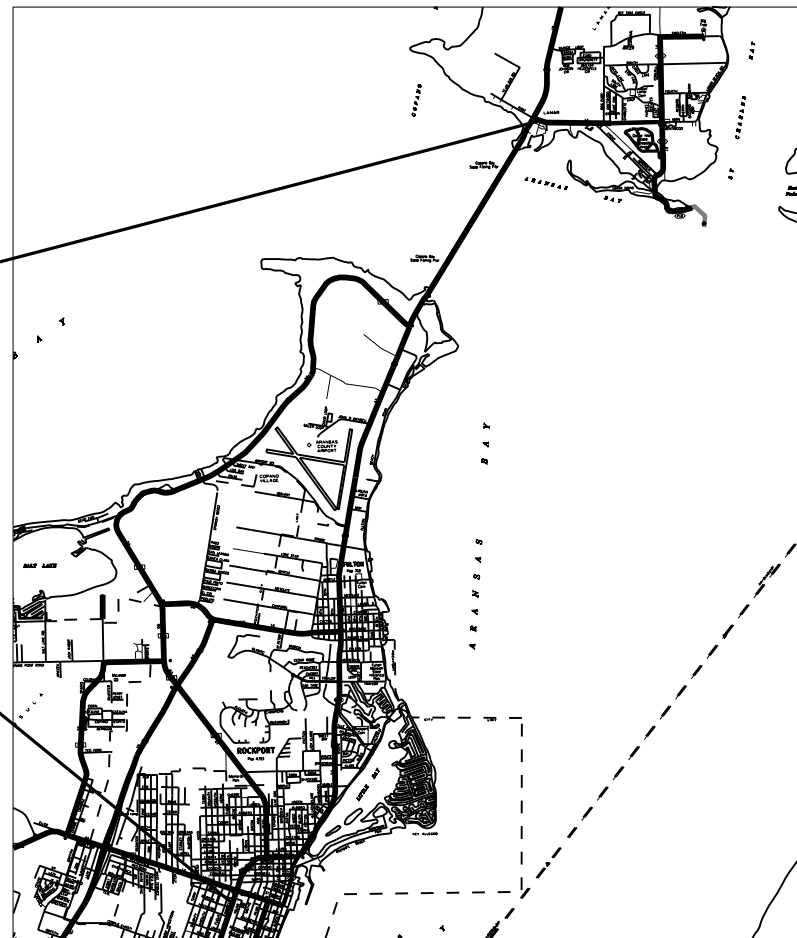

EXCEPTIONS: NONE  
EQUATIONS: NONE  
RAILROAD CROSSINGS: NONE

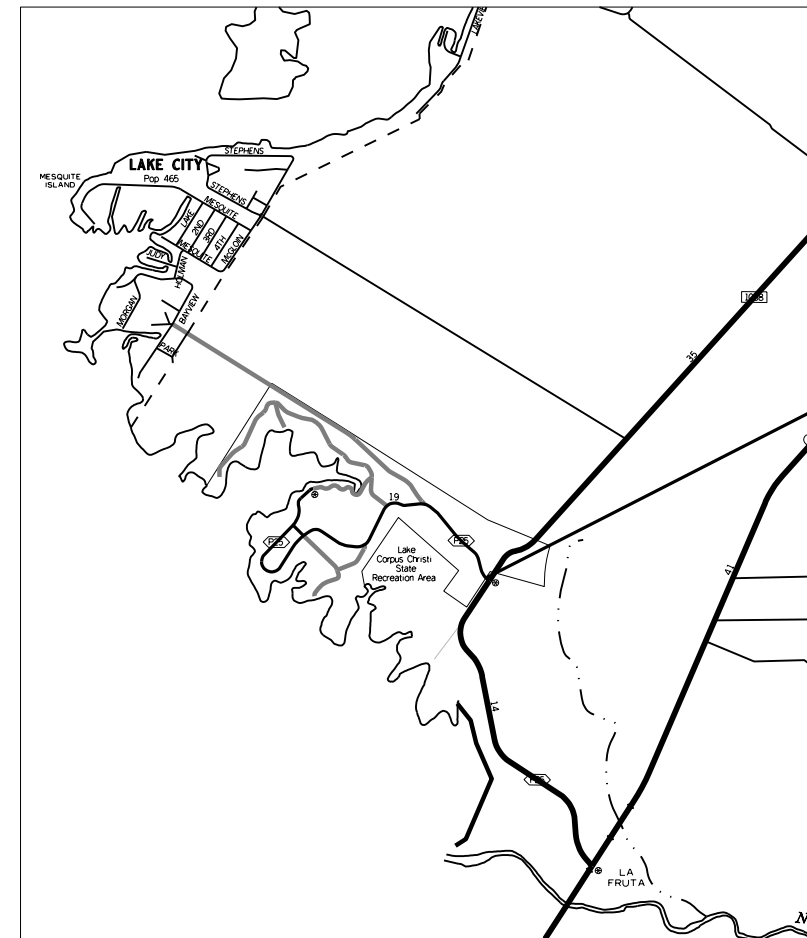

EXCEPTIONS: NONE  
EQUATIONS: NONE  
RAILROAD CROSSINGS: NONE

CONT	SECT	JOB	HIGHWAY
0916	28	071	PR 25A
DIST	COUNTY		SHEET NO.
CRP	SAN PATRICIO		1

PM DESIGN GUIDELINES  
NO RAS REVIEW REQUIRED  
STATE PARK ROADWAY

CORPUS CHRISTI STATE PARK ENTRANCE  
CSJ: 0916-28-071  
REF MRK: 596+1.443



RECOMMENDED FOR LETTING: 1/9/2023

DocuSigned by:  
*Paula Sales-Evans, P.E.*  
5975450A18CC435...  
DISTRICT DIRECTOR OF TRANSPORTATION  
PLANNING AND DEVELOPMENT

APPROVED FOR LETTING: 1/10/2023

DocuSigned by:  
*Valente Olivariz*  
303F64E8A9B44E0...  
DISTRICT ENGINEER

SPECIFICATIONS ADOPTED BY THE TEXAS DEPARTMENT OF TRANSPORTATION, NOVEMBER 1, 2014 AND SPECIFICATION ITEMS LISTED AS FOLLOWS, SHALL GOVERN ON THIS PROJECT: SPECIAL LABOR PROVISIONS FOR STATE PROJECTS: SP000---008

DATE: 1/5/2023 3:05:29 PM  
FILE: pw://txdot.projectwiseonline.com:txdot14/Documents/16 - CRP/Design Projects/091628071/4 - Design/Plan Set/1. General/TITLE SHEET

# INDEX OF SHEETS

DATE: 1/13/2023 5:12:39 PM  
FILE: D:\dot\project\wiseonline.com\TxDOT14\Documents\16 - CRP\Design Projects\091628071\4 - Design\Plan Set\1. General\INDEX OF SHEETS

<b>GENERAL</b>	
1	TITLE SHEET
2	INDEX OF SHEETS
3-4	GOOSE ISLAND STATE PARK TYPICAL SECTIONS
5-6	LAKE CORPUS CHRISTI STATE PARK TYPICAL SECTIONS
7,7A-7E	GENERAL NOTES
8	ESTIMATE & QUANTITY
9-10	GOOSE ISLAND STATE PARK ROADWAY SUMMARY
11	GOOSE ISLAND STATE PARK DRAINAGE SUMMARY
12	GOOSE ISLAND STATE PARK SURFACE DETAILS SUMMARY
13	ROCKPORT ANNEX QUANTITIES
14	LAKE CORPUS CHRISTI STATE PARK ROADWAY SUMMARY
15	LAKE CORPUS CHRISTI STATE PARK DRAINAGE SUMMARY
16	LAKE CORPUS CHRISTI STATE PARK PARKING LOTS SUMMARY
17	LAKE CORPUS CHRISTI STATE PARK RV PARKING SUMMARY
18	LAKE CORPUS CHRISTI STATE PARK SURFACE DETAILS SUMMARY
19	SEQUENCE OF CONSTRUCTION
<b>DRAINAGE STANDARDS</b>	
20	* PSET-RC
21	* PSET-SC
<b>TRAFFIC CONTROL PLAN STANDARDS</b>	
22-33	* BC(1)-21 THRU BC(12)-21
34	* TCP(1-2)-18
35	* TCP(2-2)-18
36	* TCP(S-1)-08A
37	* TCP(S-2)-08A
38	* TCP(S-2C)-10
39-40	* WZ(BTS-1)-13 THRU WZ(BTS-2)-13
41	* WZ(BRK)-13
42	* WZ(RCD)-13
43	* WZ(UL)-13
<b>ROADWAY DETAILS</b>	
44	GOOSE ISLAND STATE PARK LAYOUT MAP
45-52	GOOSE ISLAND STATE PARK ROADWAY DETAILS
53	ROCKPORT ANNEX LAYOUT SHEET
54	THE BIG TREE LAYOUT SHEET
55	LAKE CORPUS CHRISTI LAYOUT STATE PARK LAYOUT MAP
56-60	LAKE CORPUS CHRISTI STATE PARK ROADWAY DETAILS
<b>ROADWAY DETAILS STANDARDS</b>	
61	* TE(HMAC)-11
<b>PAVEMENT MARKINGS &amp; DELINEATION STANDARDS</b>	
62	* PM(1)-22
63	* PM(AP)-21
<b>ENVIRONMENTAL ISSUES</b>	
64-65	STORMWATER POLLUTION PREVENTION PLAN (SWP3)
66	ENVIRONMENTAL PERMITS, ISSUES AND COMMITMENTS
<b>ENVIRONMENTAL ISSUES STANDARDS</b>	
67	* EC(1)-16
68-70	* EC(9)-16

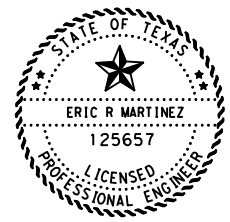

THE STANDARD SHEETS SPECIFICALLY IDENTIFIED WITH A "\*" HAVE BEEN ISSUED BY ME AND ARE APPLICABLE TO THIS PROJECT.

NAME \_\_\_\_\_ DATE 01/13/2023

## INDEX OF SHEETS

SHEET 1 OF 1

**Texas Department of Transportation**

CONT	SECT	JOB	HIGHWAY
0916	28	071	PR 25A
DIST	COUNTY		SHEET NO.
CRP	SAN PATRICIO		2

DATE: 1/13/2023 5:12:48 PM  
 FILE: p:\t\dot\project\wiseonline.com\t\dot14\Documents\16 - CRP\Design Projects\091628071\4 - Design\Plan Set\1. General\GOOSE ISLAND - ROCKPORT ANNEX\G1\_TYPICAL SECTIONS.dwg

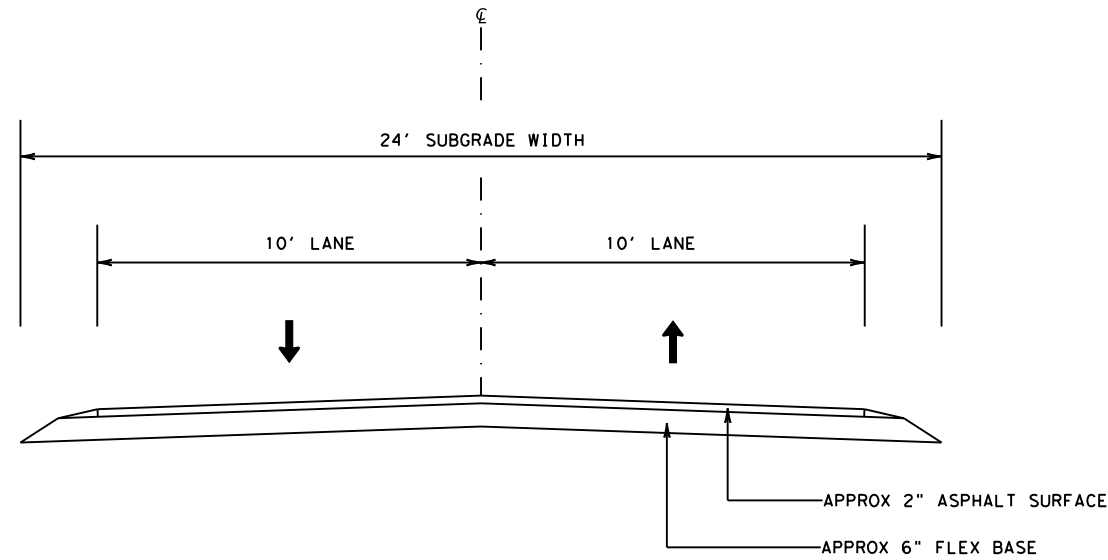

EXISTING TYPICAL SECTIONS

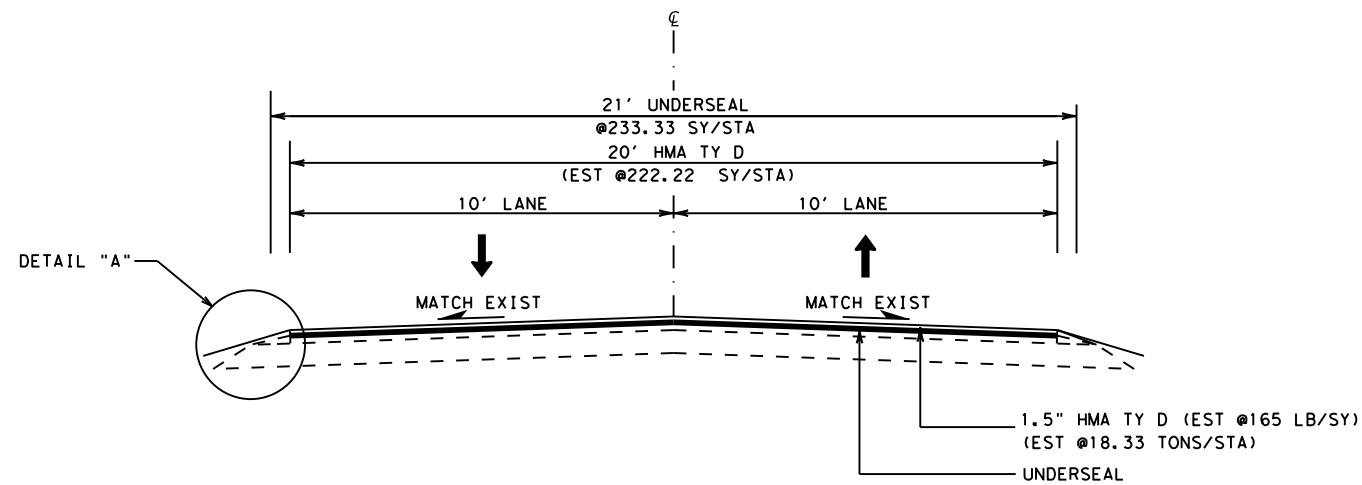

PROPOSED TYPICAL SECTION - HMA OVERLAY

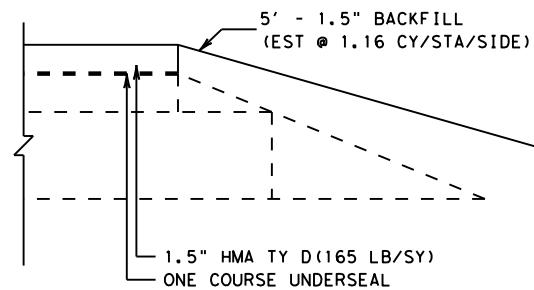

DETAIL "A"

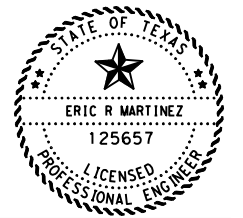

*E. Martinez, P.E.*

01/13/2023

**GOOSE ISLAND  
 STATE PARK  
 TYPICAL SECTIONS**

SHEET 1 OF 2

CONT	SECT	JOB	HIGHWAY
0916	28	071	PR 25A
DIST	COUNTY		SHEET NO.
CRP	SAN PATRICIO		3

NOT TO SCALE

DATE: 1/13/2023 5:12:48 PM  
 FILE: p:\t\dot\project\wiseonline.com\txdot14\Documents\16 - CRP\Design Projects\091628071\4 - Design\Plan Set\1. General\GOOSE ISLAND - ROCKPORT ANNEX\G1\_TYPICAL SECTIONS.g

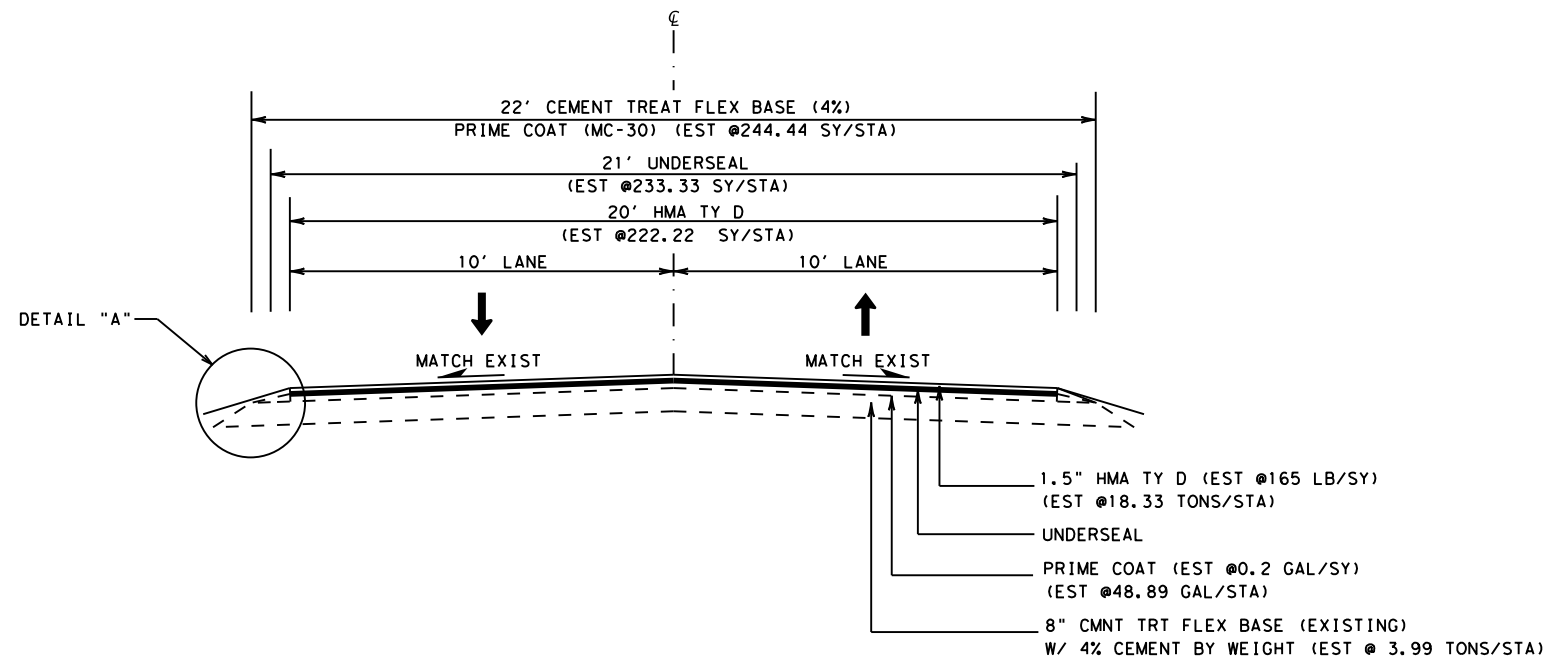

PROPOSED TYPICAL SECTION - BASE REPAIR

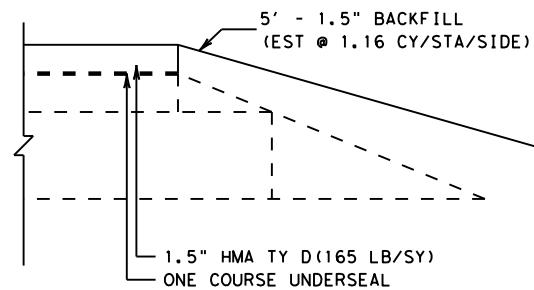

DETAIL "A"

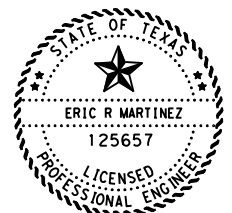

*ERM*

01/13/2023

**GOOSE ISLAND  
 STATE PARK  
 TYPICAL SECTIONS**

SHEET 2 OF 2



CONT	SECT	JOB	HIGHWAY
0916	28	071	PR 25A
DIST	COUNTY	SHEET NO.	
CRP	SAN PATRICIO	4	

NOT TO SCALE



DATE: 1/13/2023 5:12:57 PM  
 FILE: p:\dot\projectwiseonline.com\txdot\Documents\16 - CRP\Design Projects\091628071\4 - Design\Plan Set\1. General\LAKE CORPUS CHRISTI\LAKE CORPUS TYPICAL SECTION SHEET.CAD

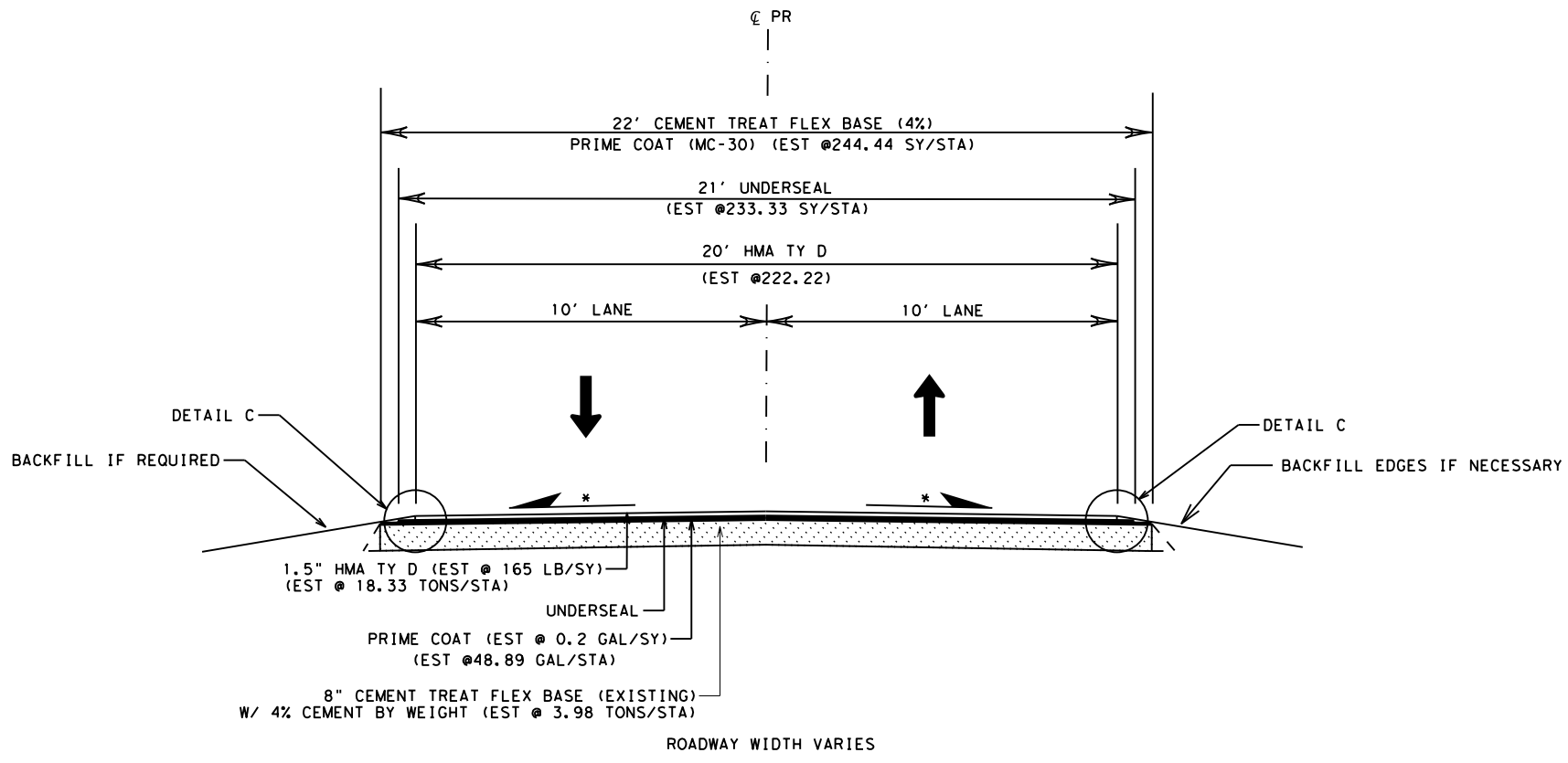
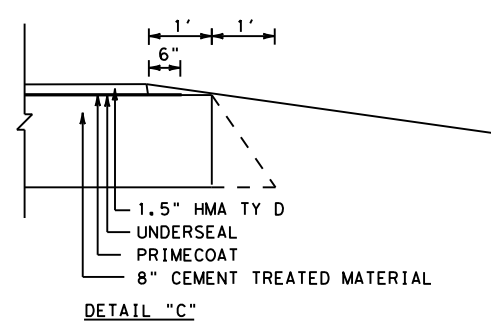

PROPOSED TYPICAL SECTIONS - BASE REPAIR

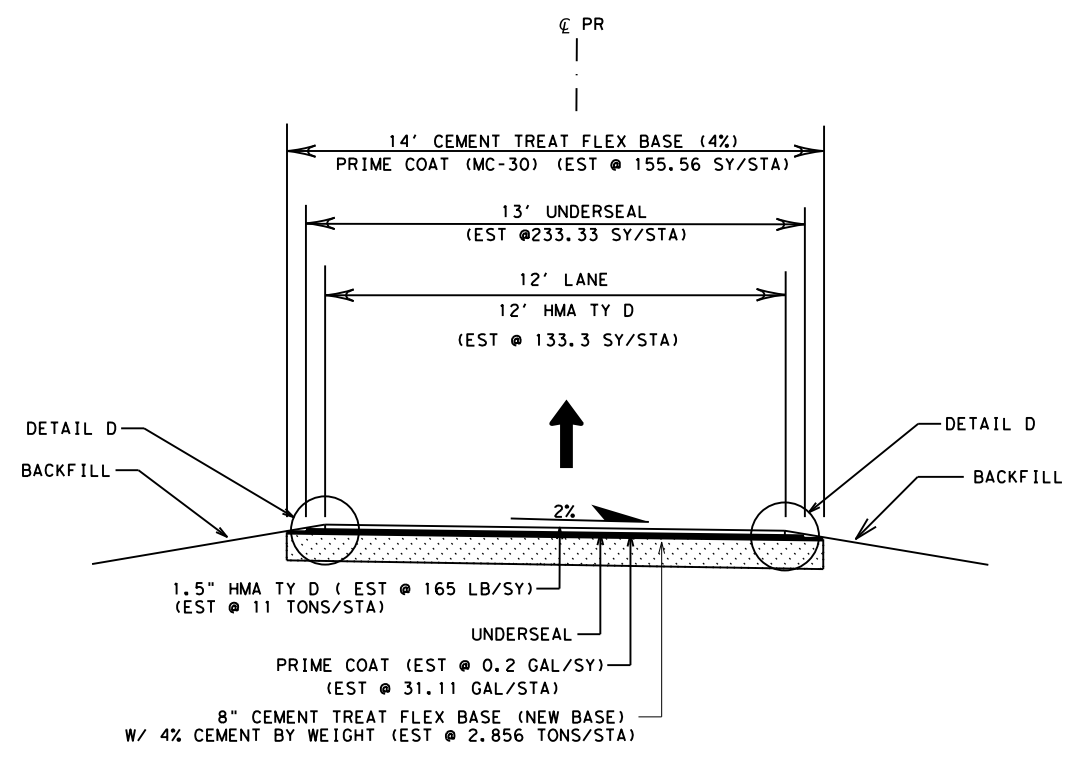
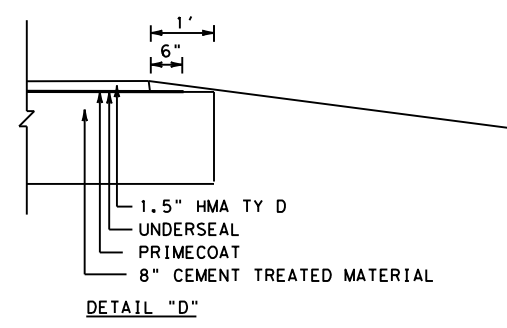

PROPOSED TYPICAL SECTIONS - CAVE SWALLOW EXTENSION

NOTES:  
 \* MATCH EXISTING CROSS SLOPE  
 MIN 3:1 BACKFILL SLOPES  
 MAX:6:1 BACKFILL SLOPES  
 NOT TO SCALE

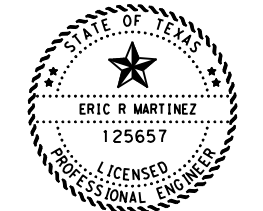

*E. Martinez*

01/13/2023  
 LAKE CORPUS CHRISTI  
 STATE PARK  
 TYPICAL SECTIONS

SHEET 2 OF 2

CONT	SECT	JOB	HIGHWAY
0916	28	071	PR 25A
DIST	COUNTY	SHEET NO.	
CRP	SAN PATRICIO	6	

County: SAN PATRICIO

CSJ: 0916-28-071

Highway: PR 25A

**GENERAL NOTES:**

Find, for your information and convenience, tools such as forms, software, materials, and various other information provided by the Department at <https://www.txdot.gov/business.html>. Please note that these tools are updated periodically and your attention is directed to the latest edition.

In the event of a called evacuation, emergencies, impending adverse weather or as directed, do not perform any work without written authorization. The District reserves the right to suspend all work in support of evacuations or emergencies occurring from other parts of the state. Any work performed, other than work directed by the Department, is unauthorized work in accordance with Item 5.

Sweep, clean and remove any construction waste, surplus materials or debris from the roadway and right of way at the end of each day unless otherwise approved. The work performed will not be measured or paid for directly, but will be subsidiary to pertinent items.

Asphalt application season will be established in accordance with Item 316.4.4 Adverse Weather Conditions or as directed by the Engineer.

Cut existing pavement using a saw or other approved method to ensure a neat transverse and/or longitudinal line to assure a smooth tie-in with new pavement. Cut to a minimum depth of the final lift thickness. The work performed will not be measured or paid for directly, but will be subsidiary to pertinent Items.

Promptly pick up and properly dispose of paper and other materials used for pavement joints.

All pavement markings shall be in accordance with the latest edition of Texas MUTCD.

Contractor questions on this project are to be addressed to the following individual(s):

Robert Isassi, P.E.      [Robert.Isassi@txdot.gov](mailto:Robert.Isassi@txdot.gov)  
Orlando Gallegos, P.E.      [Jose.Gallegos@txdot.gov](mailto:Jose.Gallegos@txdot.gov)

Questions may be submitted via the Letting Pre-Bid Q&A web page. This webpage can be accessed from the Notice to Contractors dashboard located at the following Address:

<https://tableau.txdot.gov/views/ProjectInformationDashboard/NoticetoContractors>

All contractor questions will be reviewed by the Engineer. All questions and any corresponding responses that are generated will be posted through the same Letting Pre-Bid Q&A web page.

The Letting Pre-Bid Q&A web page for each project can be accessed by using the dashboard to navigate to the project you are interested in by scrolling or filtering the dashboard using the controls on the left. Hover over the blue hyperlink for the project you want to view the Q&A for and click on the link in the window that pops up.

County: SAN PATRICIO

CSJ: 0916-28-071

Highway: PR 25A

**ITEM 2**

It is recommended that prospective bidders examine the specified work locations with the Engineer to view the nature of the work, the need for close coordination with the various utilities, traffic control considerations, and other factors influencing the prosecution of the work.

**ITEM 5**

Field verify all dimensions and notify Engineer prior to initiating any work.

Verify the locations of utilities, underground or overhead, shown within the limits of the right-of-way. Adhere to OSHA Standards when working within the vicinity of overhead power lines. Coordinate with the utility companies and notify the Engineer of any possible conflicts. The work performed will not be measured or paid for directly, but will be subsidiary to pertinent Items.

The 811 call services for a utility location does not include TxDOT facilities. Provide notification to the District Traffic Signal Shop by email at [CRP\\_Utility\\_Locate@txdot.gov](mailto:CRP_Utility_Locate@txdot.gov) or call 361-739-6044 when planning, drilling, or excavating in areas where existing TxDOT underground utilities exist. Visual evidence of TxDOT underground utilities in the area include illumination poles, ground boxes, flashing beacons, traffic signals, etc. This notification must be provided 48 hours in advance of performing the work, but no earlier than 72 business hours before the work will commence. Drilled shaft locations or excavation areas must be staked prior to the notification so that the underground utilities can be located in relationship to the proposed work.

Notify the Engineer immediately of utility conflicts in accordance with Item 5.6. Refer to Item 4.5 for consideration of differing site conditions.

Establish and mark the location of existing standard pavement markings including but not limited to edge lines, transitions, passing and no passing zones, gore areas, etc.

**ITEM 6**

Inspection at Precast Concrete Fabrication Plants is as follows: TxDOT's Materials and Pavements Section will inspect any precast units at commercial fabrication yards and staging areas. The Area Engineer will inspect all other precast units.

For Department-furnished material, contact the Engineer or his designated representative to request material a minimum of one workday prior to pick up. Load material with contract personnel. Materials are to be stored in a safe location outside TXDOT property or right-of-way, {unless otherwise approved.} Use material furnished by the Department only on the project(s) intended. Return any unused material as soon as possible.

 © 2023 <b>GENERAL NOTES</b>	FED. RD. DIV. NO.	FEDERAL AID PROJECT NO.		HIGHWAY NO.
	6			PR 25A
	STATE	DISTRICT	COUNTY	
	TEXAS	CRP	San Patricio	
	CONTROL	SECTION	JOB	SHEET NO.
	0916	28	071	7

County: SAN PATRICIO

CSJ: 0916-28-071

Highway: PR 25A

**ITEM 7**

The work performed for Item 7.2.4, "Public Safety and Convenience" will not be measured or paid for directly, but will be subsidiary to pertinent Items.

When working at street, farm-to-market, state highway, and county road intersections, schedule work to minimize intersection closures. During nonworking hours, all public road intersections will be open to the traveling public.

The total disturbed area for this project is 24.2 acres. The disturbed area in this project, all project locations in the Contract, and Contractor project specific locations (PSLs), within 1 mile of the project limits, for the Contract will further establish the authorization requirements for storm water discharges. The Department will obtain an authorization to discharge storm water from the Texas Commission on Environmental Quality (TCEQ) for the construction activities shown on the plans. The Contractor is to obtain any required authorization from the TCEQ for any Contractor PSLs for construction support activities on or off ROW. When the total area disturbed for all projects in the Contract and PSLs within 1 mile of the project limits exceeds 5 acres, provide a copy of the Contractor NOI for PSLs on the ROW to the Engineer.

Establish uniform perennial vegetative coverage with a density of at least 70% of the native background vegetative cover to achieve final stabilization.

Comply with the Texas Aggregate Quarry and Pit Safety Act for waste areas or material source areas resulting from this project.

No significant traffic generator events identified.

Submit charge summary and invoices for Law Enforcement Personnel using the Department forms.

Patrol vehicles must be clearly marked to correspond with the officer's agency and equipped with appropriate lights to identify them as law enforcement. For patrol vehicles not owned by a law enforcement agency, markings will be retroreflective and legible from 100 ft. from both sides and the rear of the vehicle. Lights will be high intensity and visible from all angles. No payment will be made for law enforcement personnel needed for moving equipment or payment for drive time to/from the event site.

If the Contractor has a field office, provide an office location for a supervisory officer when event requires a supervising officer. This work is subsidiary.

A maximum combined rate of \$70 per hour for the law enforcement personnel and the patrol vehicle will be allowed. Any scheduling fee is subsidiary per Standard Specification 502.4.2.

Cancel law enforcement personnel when the event is canceled. Cancellation, minimums or "show up" fees will not be paid when cancellation is made 12 hours prior to beginning of the

General Notes

Sheet C

County: SAN PATRICIO

CSJ: 0916-28-071

Highway: PR 25A

event. Failure to cancel within 12 hours will not be cause for payment for cancellation, minimums, or "show up" time. Payment of actual "show up" time to the event site due to cancellation will be on a case by case basis at a maximum of 2 hours per officer.

Alterations to the cancellation and maximum rate must be approved by the Engineer or pre-determined by official policy of the officers governing authority.

**ITEM 8**

Prepare the progress schedule using the Critical Path Method (CPM). Submit (2) two 11" x 17" hard copies and an electronic file of the original or updated progress schedule. Submit the original progress schedule seven (7) days before the Preconstruction Conference.

Submit an updated progress schedule as directed to show proposed major changes, changes affecting compliance with the contract requirements, or changes affecting the critical path/controlling item of work.

Working days will be computed and charge in accordance with Article 8.3.1.4, "Standard Workweek".

Work above traffic is not allowed.

Notify the Engineer at least 48 hours in advance of weekend or nighttime work.

**ITEM 9**

Monthly progress payments will be made for items of work completed by the 28th day of each month. Any work completed after the 28th will be included for payment in the subsequent monthly progress estimate.

Submit signed request for compensation of material-on-hand (MOH), including any requests from subcontractors, suppliers, or fabricators for MOH, at least two (2) working days prior to the end of the estimate cycle on the Departments approved forms.

**ITEM 100**

Coordinate all right of way preparation activities with the project's Storm Water Pollution Prevention Plan (SWP3) and Environmental Permit Issues, and Commitments Sheet (EPIC) or as approved.

General Notes

Sheet D

 © 2023 <b>GENERAL NOTES</b>	FED. RD. DIV. NO.	FEDERAL AID PROJECT NO.	HIGHWAY NO.
	6		PR 25A
	STATE	DISTRICT	COUNTY
	TEXAS	CRP	San Patricio
	CONTROL	SECTION	JOB
	0916	28	071
			SHEET NO.
			7A



County: SAN PATRICIO

CSJ: 0916-28-071

Highway: PR 25A

Prune trees and shrubs as directed. Use accepted pruning practices in accordance with Item 192 and as defined by the National Arborist Association. The work performed will not be measured or paid for directly, but will be subsidiary to pertinent Items.

**ITEM 110**

For earth cuts, manipulate and compact subgrade in accordance with Item 132.3.4.2, "Compaction Methods, Density Control".

**ITEM 134**

Use backfill material with a plasticity index (PI) ranging from 10 to 40. Notify the Engineer of the proposed material sources and of changes to material sources. The Engineer may sample and test project materials at any time before compaction throughout the duration of the project to assure specification compliance.

If Contractor elects to use R.A.P. material for backfill pavement edges, the R.A.P. material must pass a 2" sieve. All material not passing sieve will be removed and disposed of properly. This shall be considered subsidiary to Item 134.

Windrow the existing topsoil and grass along the edge of the grading operations or as directed. After grading operations are completed, spread the topsoil and grass uniformly on all slopes and ditch lines. The work performed will not be measured or paid for directly, but will be subsidiary to pertinent Items.

Manipulate and compact backfill material in accordance with Item 132.3.4.1, "Ordinary Compaction". The work performed will not be measured or paid for directly, but will be subsidiary to pertinent Items.

Apply SS-1 at a rate of application of 0.15 gallon per square yard. The work performed will not be measured or paid for directly, but will be subsidiary to pertinent Items

**ITEM 164**

Restore and seed areas not shown in the plans disturbed by the Contractor's Operations. The work performed will not be measured or paid for directly, but will be subsidiary to pertinent Items.

Use a tacking agent of 50% SS-1 and 50% water and apply the agent at a rate of .10 gal/sy or as directed. A biodegradable tacking agent may be used in lieu of the SS-1 tacking agent in accordance with the manufacturer's recommendations when approved. The work performed will not be measured or paid for directly but will be subsidiary to pertinent Items.

General Notes

Sheet E

County: SAN PATRICIO

CSJ: 0916-28-071

Highway: PR 25A

**ITEM 247**

When requested, stake with blue tops, at 100-foot intervals, the lines and grade shown in the plans.

**ITEM 275**

Cement and/or asphalt stabilized base may be encountered in the existing pavement structure. Pulverize or scarify the existing material after shaping so that 100% passes a 2-1/2 inch sieve.

Use a mechanical mixer to mix the cement with the existing base material.

The three (3) day curing period is waived for roadways required to be opened to traffic the same day.

**ITEM 302**

Provide aggregates with a minimum surface aggregate classification (SAC) of "B" unless otherwise shown. The SAC for sources on the "Department's AGGREGATE Quality Monitoring Program (AQMP) is listed in the Department's Bituminous Rated Source Quality Catalogue (BRSQC). SAC requirements apply to aggregates used on all final roadway surfaces, including shoulders.

For precoated aggregate Type PB, crushed gravel will not be used.

**ITEM 310**

Use MC-30 at a rate of 0.20 gallons per square yard or as directed.

Use SS-1 at the rate of 0.15 gallons per square yard per inch or as directed. Use a mixture of 5% SS-1 and 95% water and work the mixture into the top 2 inches of the flexible base surface. The water will not be measured or paid for directly, but will be subsidiary to pertinent Items.

A minimum prime coat curing period shall be determined by the Engineer during preconstruction meeting. This curing period may be revised by the Engineer throughout the duration of the project pending weather and observed performance.

**ITEM 316**

Do not place surface treatment on exposed concrete structures unless directed.

General Notes

Sheet F

 © 2023 <b>GENERAL NOTES</b>	FED. RD. DIV. NO.	FEDERAL AID PROJECT NO.		HIGHWAY NO.
	6			PR 25A
	STATE	DISTRICT	COUNTY	
	TEXAS	CRP	San Patricio	
	CONTROL	SECTION	JOB	SHEET NO.
	0916	28	071	7B

County: SAN PATRICIO

CSJ: 0916-28-071

Highway: PR 25A

Furnish a distributor equipped with a working hand hose.

Material rates shown are for estimating purposes only. Adjust actual rates based on the material used, the existing condition and type of roadway surface, and as approved.

When using asphalt emulsion, a minimum 24-hour curing period is required before placing any subsequent asphalt courses.

Remove vegetation and blade pavement edges prior to surfacing operations. The work performed will not be measured or paid for directly, but will be subsidiary to pertinent Items.

Broom and clean sealed sections of roadway and all adjacent paved surfaces, including the gutter line, of any surplus aggregate before opening to traffic or as directed.

**ITEM 320**

Provide the type of windrow pick-up equipment for approval prior to beginning paving operations.

Use of motor grader will not be permitted unless approved.

**ITEM 351**

Saw cut and remove the full depth of pavement repair at all transverse joints.

**ITEM 354**

Reclaimable asphalt material (RAP) may be retained only if incorporated into the project. Incorporate the RAP into the pavement mix design, into the backfill for pavement edges, into temporary structures, or as approved.

Any RAP remaining from the contract is to remain with the Contractor.

**ITEM 400**

Compact each layer to meet the density and consolidation of the adjacent undisturbed material.

Use cement-stabilized backfill for culvert and storm drains located beneath the pavement structure.

General Notes

Sheet G

County: SAN PATRICIO

CSJ: 0916-28-071

Highway: PR 25A

**ITEM 464**

The work performed for concrete collars will not be measured or paid for directly, but will be subsidiary to pertinent Items.

**ITEM 467**

The flowline of the safety end treatment shall match the flowline of the culvert.

Reinforce concrete riprap with 4 x 4 – W2.9 x W2.9 welded wire fabric or with No. 3 reinforcing bars spaced at a maximum of 12 inch in each direction.

The work performed for concrete collars will not be measured or paid for directly, but will be subsidiary to pertinent Items.

All safety end treatments shall include riprap to the dimensions shown on PSET-RR. This riprap shall be subsidiary to Item 467.

Riprap apron shall be considered subsidiary to pertinent items.

**ITEM 496**

The structure(s) to be removed have surface coatings which may contain hazardous materials. Provide for the safety and health of employees and abide by all OSHA Standards and Regulations.

All removed material shall be disposed of by the contractor. The work performed will not be measured or paid for directly, but will be subsidiary to pertinent Items.

**ITEM 500**

"Materials on Hand" payments are not considered when determining partial payments.

**ITEM 502**

Furnish additional barricades, signs, and traffic handling as directed. The work performed will not be measured or paid for directly, but will be subsidiary to pertinent Items.

Traffic control for daytime lane closures shall be in accordance with applicable standards. Traffic control shall include temporary rumble strips in accordance with WZ (RS)-22.

General Notes

Sheet H

 © 2023 <b>GENERAL NOTES</b>	FED. RD. DIV. NO.	FEDERAL AID PROJECT NO.		HIGHWAY NO.
	6			PR 25A
	STATE	DISTRICT	COUNTY	
	TEXAS	CRP	San Patricio	
	CONTROL	SECTION	JOB	SHEET NO.
	0916	28	071	7C

County: SAN PATRICIO

CSJ: 0916-28-071

Highway: PR 25A

When advanced warning flashing arrow panels are specified, furnish one (1) standby unit in good condition at the job site for immediate use.

Attach stop/slow paddle to a staff with a minimum length of 6 feet to the bottom of the sign.

The use of a pilot vehicle in conjunction with flaggers will be permitted. If used, provide positive and unrestricted communication between the driver of the pilot vehicle and the flaggers. The work performed will not be measured or paid for directly, but will be subsidiary to pertinent Items.

Contractors' attention is directed to a construction speed zone, signage is subsidiary to Item 502.

The Contractor Force Account "Safety Contingency" that has been established for this project is intended to be utilized for work zone enhancements, to improve the effectiveness of the Traffic Control Plan, that could not be foreseen in the project planning and design stage. These enhancements will be mutually agreed upon by the Engineer and the Contractor's Responsible Person based on weekly or more frequent traffic management reviews on the project. The Engineer may choose to use existing bid items if it does not slow the implementation of enhancement.

All items marked as optional on all traffic control standards shall be required unless otherwise approved by an Engineer.

Trail vehicle shall be required on all mobile traffic control operations. (For TCP 3 series)

**ITEM 504**

No field office will be required for this project.

**ITEM 506**

Designate in writing a Contractor Responsible Person (CRP) for implementing, maintaining, and reviewing environmental requirements.

**ITEM 585**

Use Surface Test Type B and Pay Adjustment Schedule 3 to evaluate ride quality of the travel lanes in accordance with Item 585, "Ride Quality for Pavement Surfaces."

General Notes

Sheet I

County: SAN PATRICIO

CSJ: 0916-28-071

Highway: PR 25A

**ITEM 662**

Use temporary flexible-reflective roadway marker tabs at the beginning and end of no passing zones as shown on the TCP (7-1)-13 for seal coats and WZ(STPM)-13 for hot mix overlays. Reference Standard Sheets

**ITEM 666**

Establish and mark the location of existing standard pavement markings including but not limited to edge lines, transitions, passing and no passing zones, gore areas, etc.

**ITEM 3076**

SAC requirements apply to aggregates used on all surfaces.

Construct longitudinal joints with a joint maker providing a maximum one (1) inch vertical edge (1/2 inch desirable) with an adjacent 6:1 taper. Backfill edges within the same day.

The Engineer reserves the right to test all sources even if the source is listed in the Bituminous Source Rated Quality Catalog

Provide the testing lab samples to calibrate the ignition oven no later than five (5) working days prior to mix design verification.

Place HMA utilizing an automatic, dual, longitudinal-grade control system and automatic transverse-grade control system as specified under Item 320, unless otherwise approved by the Engineer.

Contractor shall temporarily cover all inlets during the milling and paving operations. Inlets shall be uncovered when milling and paving operations are complete. This shall be subsidiary to Item 3076 and not paid for directly.

**ITEM 6001**

Furnish the portable changeable message signs displaying the correct message at least seven (7) days prior to beginning work or as directed.

The Contractor's Responsible Person (CRP) will maintain full control of messages at all times.

The Engineer will provide the sign message text to use at each sign.

General Notes

Sheet J

 © 2023 <b>GENERAL NOTES</b>	FED. RD. DIV. NO.	FEDERAL AID PROJECT NO.	HIGHWAY NO.
	6		PR 25A
	STATE	DISTRICT	COUNTY
	TEXAS	CRP	San Patricio
	CONTROL	SECTION	JOB
	0916	28	071
			SHEET NO.
			7D

County: SAN PATRICIO

CSJ: 0916-28-071

Highway: PR 25A

A minimum of 2 PCMS will be required. However, additional units may be necessary depending on the work in progress.

Standby time will not be measured or paid for directly but will be subsidiary to pertinent Items.

Portable changeable message signs may be moved, and message changed at any time as deemed necessary by the Engineer. This will be considered subsidiary to Item 6001.

**ITEM 6185**

A minimum of 2 TMS will be required. However, additional units may be necessary depending on the work in progress

Provide manufacturer's curb weight or certified scales weight ticket to the Engineer for approval.

General Notes

Sheet K

County: SAN PATRICIO

CSJ: 0916-28-071

Highway: PR 25A

\*\*\*\*\*

**SPECIFICATIONS DATA**

**UNIT WEIGHT ESTIMATES**

ITEM 275 – CEMENT TRT (EXIST MATERIAL)(8")(4% BY WT)----- 136 LBS/CF  
ITEM 247 – (8") FL BS (CMP IN PLC) (TY A GR 5)(FNAL POS) ----- 136 LBS/CF  
ITEM 3076 – (1.5") HMA TY-D ----- 165 LBS/SY

**COMPACTION REQUIREMENTS**

ITEM 247 ----- FL BS (CMP IN PLC)(TY A GR 5)(FNAL POS)  
DENSITY ----- 100% MIN  
LIFTS ----- ALL

**PRIME COAT**

ASPHALT TYPE ----- MC-30  
AVERAGE ASPHALT RATE (GAL/SY) ----- 0.20

**UNDERSEAL**

ASPHALT TYPE ----- (AC-10, CRS-2, OR HFRS-2)  
ASPHALT RATE ----- 0.31 - 0.39 GAL/SY  
AVERAGE ASPHALT RATE ----- 0.35 GAL/SY  
AGGREGATE TYPE ----- -PB  
AGGREGATE GRADE ----- 3/3S SAC-B  
AGGREGATE RATE----- 1/110 CY/ SY

**ONE COURSE SURFACE TREATMENT**

ASPHALT TYPE ----- (AC-15P, HFRS-2P, OR CRS-2P)  
ASPHALT RATE(GAL/SY) ----- 0.31 – 0.39  
AVERAGE ASPHALT RATE (GAL/SY) ----- 0.35  
AGGREGATE TYPE ----- PB  
AGGREGATE GRADE ----- 4/4S SAC-B  
AGGREGATE RATE (CY/SY) ----- 1/110

General Notes

Sheet L

 © 2023 <b>GENERAL NOTES</b>	FED. RD. DIV. NO.	FEDERAL AID PROJECT NO.	HIGHWAY NO.
	6		PR 25A
	STATE	DISTRICT	COUNTY
	TEXAS	CRP	San Patricio
	CONTROL	SECTION	JOB
	0916	28	071
			SHEET NO.
			7E



CONTROLLING PROJECT ID 0916-28-071

DISTRICT Corpus Christi  
HIGHWAY PR 25A, PW

COUNTY Aransas, San Patricio

# Estimate & Quantity Sheet

ALT	BID CODE	DESCRIPTION	UNIT	EST.	FINAL
	104-6011	REMOVING CONC (MEDIANS)	SY	56.000	
	104-6013	REMOVING CONC (FOUNDATIONS)	SY	2.000	
	110-6001	EXCAVATION (ROADWAY)	CY	170.000	
	134-6006	BACKFILL (TY A)	LF	26,847.000	
	247-6366	FL BS (CMP IN PLC)(TY A GR 5)(FNAL POS)	CY	136.000	
	275-6001	CEMENT	TON	731.000	
	275-6009	CEMENT TREAT (NEW BASE) (8")	SY	610.000	
	275-6011	CEMENT TREAT(EXIST MATL)(8")	SY	43,757.000	
	310-6009	PRIME COAT (MC-30)	GAL	8,878.000	
	316-6001	ASPH (MULTI OPTION)	GAL	35,658.000	
	316-6413	ASPH(AC-15P, HFRS-2P OR CRS-2P)	GAL	3,987.000	
	316-6427	AGGR(TY-PB GR-4S OR TY-PB GR-4)(SAC-B)	CY	115.000	
	316-6430	AGGR(TY-PB GR-3 OR TY-PB GR-3S)(SAC-B)	CY	967.000	
	351-6012	FLEXIBLE PAVEMENT STRUCTURE REPAIR(2")	SY	14.000	
	400-6012	CUT AND RESTORE PAV (FLEX BASE)	SY	46.000	
	464-6001	RC PIPE (CL III)(12 IN)	LF	64.000	
	464-6002	RC PIPE (CL III)(15 IN)	LF	32.000	
	464-6005	RC PIPE (CL III)(24 IN)	LF	108.000	
	467-6322	SET (TY II) (12 IN) (RCP) (3: 1) (C)	EA	4.000	
	467-6336	SET (TY II) (15 IN) (RCP) (3: 1) (C)	EA	2.000	
	467-6388	SET (TY II) (24 IN) (RCP) (3: 1) (C)	EA	6.000	
	496-6007	REMOV STR (PIPE)	LF	204.000	
	500-6001	MOBILIZATION	LS	1.000	
	502-6001	BARRICADES, SIGNS AND TRAFFIC HANDLING	MO	5.000	
	506-6041	BIODEG EROSN CONT LOGS (IN STL) (12")	LF	500.000	
	506-6043	BIODEG EROSN CONT LOGS (REMOVE)	LF	500.000	
	666-6041	REFL PAV MRK TY I (W)12"(SLD)(090MIL)	LF	36.000	
	666-6302	RE PM W/RET REQ TY I (W)4"(SLD)(090MIL)	LF	15,738.000	
	666-6317	RE PM W/RET REQ TY I (Y)6"(BRK)(090MIL)	LF	5,104.000	
	666-6356	REFL PAV MRK TY II (R&W)6"(FIRE LANE)	LF	50.000	
	668-6055	PRE PM TY B(ACC PRK)(BL&WH)(W/BORDR)LG	EA	21.000	
	668-6085	PREFAB PAV MRK TY C (W) (WORD)	EA	34.000	
	672-6008	REFL PAV MRKR TY I-R	EA	12.000	
	3076-6042	D-GR HMA TY-D SAC-B PG70-22	TON	8,370.000	
	5008-6002	MOVE AND RESET PRECAST CONC WHEEL STOPS	EA	488.000	
	6001-6001	PORTABLE CHANGEABLE MESSAGE SIGN	DAY	72.000	
	6185-6002	TMA (STATIONARY)	DAY	72.000	
	18	SAFETY CONTINGENCY: CONTRACTOR FORCE ACCOUNT WORK (PARTICIPATING)	LS	1.000	
		EROSION CONTROL MAINTENANCE: CONTRACTOR FORCE ACCOUNT WORK (PART)	LS	1.000	

DISTRICT	COUNTY	CCSJ	SHEET
Corpus Christi	San Patricio	0916-28-071	8

CSJ: 0916-38-012 GOOSE ISLAND ROADWAY QUANTITIES SUMMARY												
LOCATION	LENGTH	WIDTH	SURFACE AREA	SURFACE AREA	134	275	275	310	316	316	3076	5008
					6006	6001	6011	6009	6001	6430	6042	6002
					BACKFILL TY A	CEMENT	CEMENT TREAT (EXIST MATL) 8"	PRIME COAT (MC-30)	ASPH (MULTI OPTION)	AGGR (TY-PB GR-3 OR TY-PB GR-3S) (SAC-B)	D-GR HMA TY-D SAC-B PG (70-22)	MOVE AND RESET PRECAST CONC WHEEL STOPS
FT	FT	SF	SY	CY	TON	SY	GAL	GAL	CY	TON	EA	
<b>LANTANA LOOP</b>	5653	20	113060	12563	393	226	13819	2764	4617	120	1037	
PARKING LOT 1			1139	127					45	2	11	4
PARKING LOT 2			1333	149					53	2	13	6
PARKING LOT 3			2537	282					99	3	24	10
PARKING LOT 4			4950	550					193	5	46	6
PARKING LOT 5			2624	292					103	3	25	
MAINTENANCE PARKING LOT			12230	1359					476	13	113	
<b>BAYBERRY DRIVE</b>	666	20	13320	1480	47				544	15	123	
RESTROOM 1			1878	209					74	2	18	
<b>LIVE OAK CIRCLE</b>	694	20	13880	1543	49	28	1697	340	567	15	128	
PARKING LOT 1			1110	124					44	2	11	5
<b>WARBLER WAY</b>	1170	20	23400	2600	82	47	2860	572	956	25	215	
PARKING LOT 1			5299	589					207	6	49	4
RESTROOM 2			1756	196					69	2	17	6
<b>PARKROAD 13B</b>												
RV PULL-THROUGH			4650	732					257	7	61	
PARKING LOT 1			32759	3640					1274	34	301	49
PARKING LOT 2			19586	2177					762	20	180	27
PARKING LOT 3 (BOAT RAMP)			15674	1742					610	16	144	13
PARKING LOT 4			14054	1562					547	15	129	
PARKING LOT 5			2637	293					103	3	25	
PARKING LOT 6			1503	167					59	2	14	
RESTROOM 4			3084	343					121	4	29	
RESTROOM 3			2150	239					84	3	20	
<b>THE BIG TREE</b>			13995	1555					545	15	129	
RV BACK-INS				4136					1438	38	339	
<b>WARBLER WAY DRIVEWAYS</b>				1014					343	13	87	
<b>TOTALS:</b>	<b>8183</b>			<b>39663</b>	<b>571</b>	<b>301</b>	<b>18376</b>	<b>3676</b>	<b>14190</b>	<b>385</b>	<b>3288</b>	<b>130</b>

**GOOSE ISLAND  
 STATE PARK  
 ROADWAY SUMMARY**

SHEET 1 OF 2



CONT	SECT	JOB	HIGHWAY
0916	28	071	PR 25A
DIST	COUNTY	SHEET NO.	
CRP	SAN PATRICIO	9	

DATE: 1/13/2023 5:13:06 PM  
 FILE: \\txdot.projectwiseonline.com:txdot\Documents\16 - CRP\Design Projects\091628071\4 - Design\Plan Set\1. General\GOOSE ISLAND - ROCKPORT ANNEK\GOOSE ISLAND ROADWAY SUMMARY

CSJ: 0916-38-012 GOOSE ISLAND RV DRIVEWAYS QUANTITIES						
LOCATION	NO OF RV BACK-IN LOTS	SURFACE AREA	SURFACE AREA	316	316	3076
				6001	6430	6042
		SF	SY	ASPH (MULTI OPTION) GAL	AGGR (TY-PB GR-3 OR TY-PB GR-3S) (SAC-B) CY	D-GR HMA TY-D SAC-B PG(70-22) TON
<b>LANTANA LOOP</b>						
RV BACK-INS*	44	36960	4107	1438	38	339
<b>WARBLER WAY</b>						
DRIVEWAY 120		551	62	22	1	6
DRIVEWAY 121		660	74	26	1	7
DRIVEWAY 122		626	70	25	1	6
DRIVEWAY 123		697	78	28	1	7
DRIVEWAY 124		648	72	26	1	6
DRIVEWAY 125		573	64	23	1	6
DRIVEWAY 126		686	77	27	1	7
DRIVEWAY 127		697	78	28	1	7
DRIVEWAY 128		693	77	27	1	7
DRIVEWAY 129		691	77	27	1	7
DRIVEWAY 130		696	78	28	1	7
DRIVEWAY 131		714	80	28	1	7
DRIVEWAY 132		696	78	28	1	7
<b>TOTAL (DRIVEWAYS)</b>		<b>8628</b>	<b>965</b>	<b>343</b>	<b>13</b>	<b>87</b>

\*RV BACK-IN LOT MEASUREMENTS SHOWN ON DETAIL

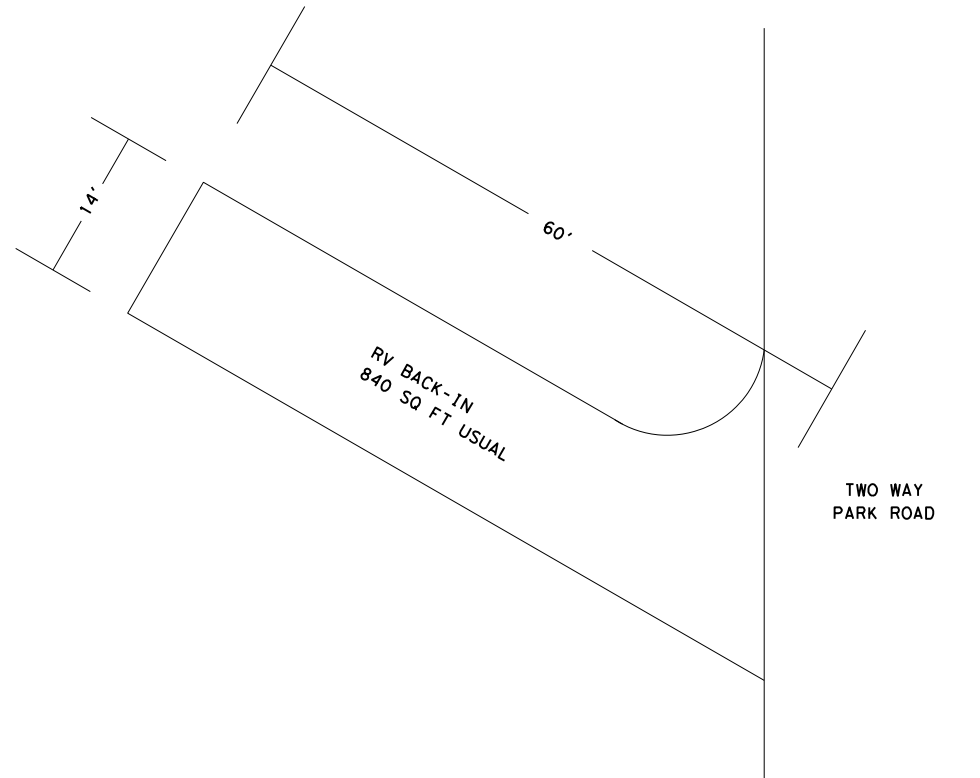

PLAN VIEW  
TYPICAL LANTANA LOOP RV BACK-IN LOT DETAIL

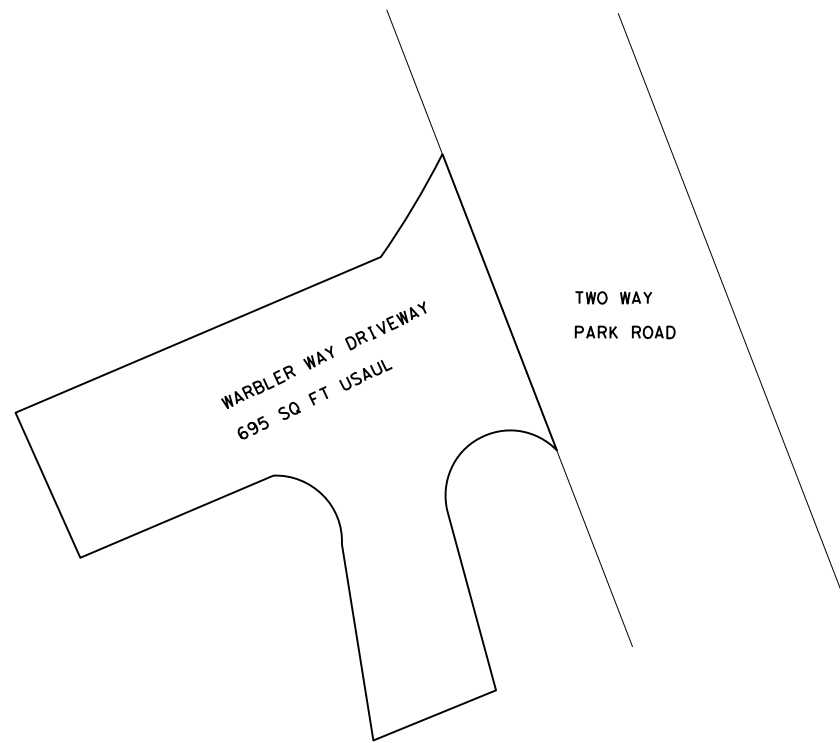

PLAN VIEW  
TYPICAL WARBLER WAY RV DRIVEWAY DETAIL

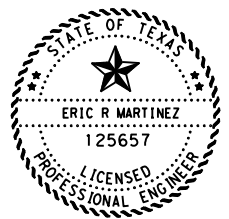

*E. Martinez*

01/13/2023

**GOOSE ISLAND  
STATE PARK  
ROADWAY SUMMARY**

SHEET 2 OF 2



CONT	SECT	JOB	HIGHWAY
0916	28	071	PR 25A
DIST	COUNTY	SHEET NO.	
CRP	SAN PATRICIO	10	

NOT TO SCALE

CSJ: 0916-38-012 - GOOSE ISLAND					
LOCATION	464	464	467	467	496
	6001	6002	6322	6336	6007
	RC PIPE (CL III) (12 IN)	RC PIPE (CL III) (15 IN)	SET (TY II) (12 IN) (RCP) (3:1) (C)	SET (TY II) (15 IN) (RCP) (3:1) (C)	REMOV STR (PIPE)
	LF	LF	EA	EA	LF
<b>Lantana Loop</b>					
DRAINAGE 1	32		2		32
DRAINAGE 2	32		2		32
<b>Warbler Way</b>					
DRAINAGE 1		32		2	32
<b>TOTALS</b>	<b>64</b>	<b>32</b>	<b>4</b>	<b>2</b>	<b>96</b>

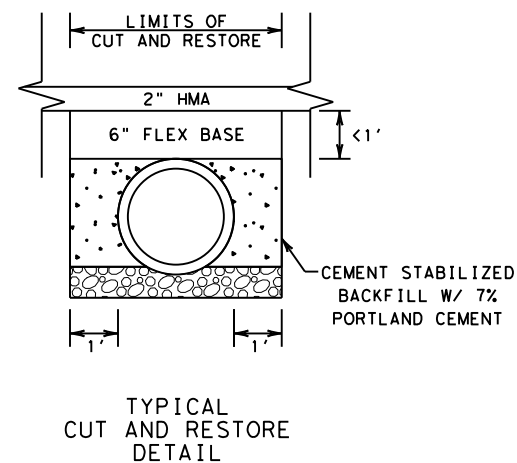

TYPICAL CUT AND RESTORE DETAIL  
(IF DEPTH BETWEEN PAVEMENT AND PIPE < 1')

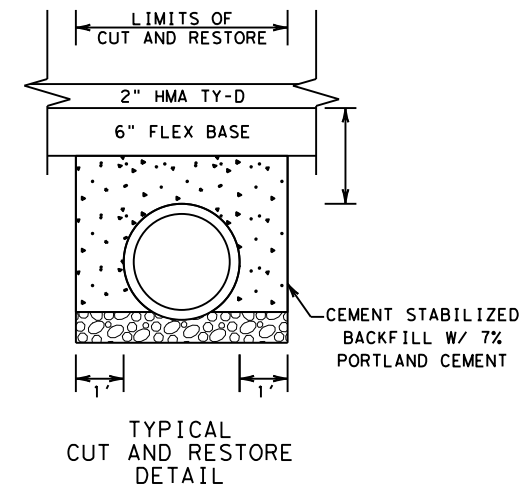

TYPICAL CUT AND RESTORE DETAIL  
(IF DEPTH BETWEEN PAVEMENT AND PIPE > 1')

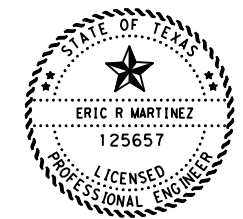

*E. Martinez*

01/13/2023  
**GOOSE ISLAND  
 STATE PARK  
 DRAINAGE SUMMARY**

SHEET 1 OF 1

CONT	SECT	JOB	HIGHWAY
0916	28	071	PR 25A
DIST	COUNTY		SHEET NO.
CRP	SAN PATRICIO		11



CSJ: 0916-38-012 - GOOSE ISLAND STATE PARK SURFACE QUANTITIES				
LOCATION	666	666	668	668
	6302	6317	6055	6085
	RE PM W/ RET REQ TY I (W) 4" (SLD) (90MIL)	RE PM W/ RET REQ TY I (Y) 6" (BRK) (090 MIL)	PRE PM TY B (ACC PRK) (BL&WH) (W/ BORDER) LG	PREFAB MRK TY C (W) (WORD)
	LF	LF	EA	EA
<b>LANTANA LOOP</b>		1414		
PARKING LOT 1	130			
PARKING LOT 2	186			
PARKING LOT 3	270			
PARKING LOT 4	242			
PARKING LOT 5	242			
MAINTENANCE PARKING LOT				
<b>BABERRY DRIVE</b>		167		
RESTROOM #1	183		1	2
<b>LIVE OAK CIRCLE</b>		174		
PARKING LOT 1	158			
<b>WARBLER WAY</b>		293		
PARKING LOT 1	242			
RESTROOM 2	303		1	2
<b>PARK ROAD 13B</b>				
PARKING LOT 1				
PARKING LOT 2	1979		4	4
PARKING LOT 3	863		2	2
PARKING LOT 4 (BOAT RAMP)	787			
PARKING LOT 5			1	2
PARKING LOT 6	298			
PARKING LOT 7	214			
RESTROOM 3	285		2	2
RESTROOM 4	213		1	2
RESTROOM 5	213		1	2
<b>THE BIG TREE</b>	396		1	2
<b>TOTALS:</b>	<b>7204</b>	<b>2048</b>	<b>14</b>	<b>20</b>

**GOOSE ISLAND  
 STATE PARK  
 SURFACE DETAILS  
 SUMMARY**

SHEET 1 OF 1



CONT	SECT	JOB	HIGHWAY
0916	28	071	PR 25A
DIST	COUNTY		SHEET NO.
CRP	SAN PATRICIO		12

CSJ: 0916-38-011 ROCKPORT ANNEX ROADWAY QUANTITIES SUMMARY							
LOCATION			104	104	316	316	3076
			6011	6013	6001	6430	6042
	SURFACE AREA	SURFACE AREA	REMOVING CONC (MEDIANS)	REMOVING CONC (FOUNDATIONS)	ASPH (MULTI OPTION)	AGGR (TY-PB GR-3 OR TY-PB GR-3S) (SAC-B)	D-GR HMA TY-D SAC-B PG (70-22)
	SF	SY	SY	SY	GAL	CY	TON
<b>ROCKPORT ANNEX</b>							
FRONT PARKING LOT	11134	1238	56	2	434	12	103
BACK PARKING LOT	15071	1675			587	16	139
<b>TOTALS</b>		<b>2913</b>	<b>56</b>	<b>2</b>	<b>1021</b>	<b>28</b>	<b>242</b>

CSJ: 0916-38-011 - ROCKPORT ANNEX SURFACE QUANTITIES			
LOCATION	666	668	668
	6302	6055	6085
	RE PM W/ RET REQ TY I (W) 4" (SLD) (90MIL)	PRE PM TY B (ACC PRK) (BL&WH) (W/ BORDER) LG	PREFAB MRK TY C (W) (WORD)
	LF	EA	EA
<b>ROCKPORT ANNEX</b>			
FRONT PARKING LOT	613	1	2
BACK PARKING LOT	826	1	2
<b>TOTALS</b>	<b>1439</b>	<b>2</b>	<b>4</b>

**ROCKPORT ANNEX QUANTITIES**



CONT	SECT	JOB	HIGHWAY
0916	28	071	PR 25A
DIST	COUNTY		SHEET NO.
CRP	SAN PATRICIO		13

CSJ: 0916-28-071 LAKE CORPUS CHRISTI - ROADWAY QUANTITIES															
LOCATION	LENGTH	ROADWAY WIDTH	AREA	110	134	247	275	275	275	310	316	316	316	3076	
				6001	6006	6366	6001	6009	6011	6009	6001	6430	6413	6427	6042
				EXCAVATION (ROADWAY)	BACKFILL TY A	FLEX BASE (CMP IN PLC) (TYA GR 5) (FINAL POS)	CEMENT	CEMENT TREAT NEW BASE 8"	CEMENT TREAT (EXIST MATL) 8"	PRIME COAT (MC-30)	ASPH (MULTI OPTION)	AGGR (TY-PB GR-3 OR TY-PB GR-3S) (SAC-B)	ASPH (AC-15P, HFRS-2P, OR CRS-2P)	AGGR (TY-PB GR-4S OR TY-PB GR-4) (SAC-B)	D-GR HMA TY-D SAC-B PG70-22
LF	LF	SY	CY	LF	CY	TON	SY	SY	GAL	GAL	CY	GAL	CY	TON	
PARK ROAD 25 (B)	2612	19	5515		5224		100		6095	1219	1931	51			455
HQ AREA			2603										833	24	
TRAILER DUMP STATION			346								122	4			29
PARK ROAD A	668	20	1774										568	17	
JAVELINA CAMPSITE (1/2)	2776	18	5552		5552		101		6169	1234	1944	51			459
JAVELINA CAMPSITE (2/2)	290		710								249	7			59
CATFISH COVE (1/2)	1875	18-20	3823		3750		63		3823	765	1339	35			316
CATFISH COVE (2/2)	1834		3117								1091	29			258
BIRD'S NEST LOOP	3280	18-20	8081										2586	74	
BIRD'S NEST LANES	1536	18	3072		1536						1076	28			254
CAVE SWALLOW COVE	865		3024								1059	28			250
CAVE SWALLOW EXTENTION	392	12	545	170	784	136	10	610		122	191	5			45
OPOSSUM BEND CAMPSITE	1361	16	2420		2722		45		2722	545	847	22			200
GREEN JAY LANE	811	18	1622		1622		30		1803	361	568	15			134
SUNSET CIRCLE	800	18	1600		1600		30		1778	356	560	15			132
RESIDENCE ROAD	418	12	558		836		11		651	131	196	6			47
MESQUITE CAMPSITE (1/2)	907	12	1210		1814		24		1411	283	424	11			100
MESQUITE CAMPSITE (2/2)	989	12	4397								1539	40			363
BASS POINT LOOP	525	12	734								257	7			61
PARK ROAD B	418	18	840		836		16		929	186	294	8			70
BOAT RAMP B			2589								907	24			214
<b>TOTALS:</b>			<b>54132</b>	<b>170</b>	<b>26276</b>	<b>136</b>	<b>430</b>	<b>610</b>	<b>25381</b>	<b>5202</b>	<b>14594</b>	<b>386</b>	<b>3987</b>	<b>115</b>	<b>3446</b>

CSJ: 0916-28-071 TEXAS PARKS & WILDLIFE SW3P SUMMARY			
LOCATION	506	506	
	6041	6043	
	BIODEG EROSN CONT LOGS (INSTALL) (12")	BIODEG EROSN CONT LOGS (REMOVE)	
LF	LF		
LAKE CORPUS CHRISTI STATE PARK	250	250	
GOOSE ISLAND STATE PARK	250	250	
<b>TOTALS:</b>	<b>500</b>	<b>500</b>	

CSJ: 0916-28-071 LAKE CORPUS CHRISTI PLANING SUMMARY		
LOCATION	AREA	351
		6012
		FLEXIBLE PAVEMENT STRUCTURE REPAIR (2")
SY	SY	
JAVELINA CAMPSITE	14	14
<b>TOTALS:</b>	<b>14</b>	

AREA WAS CALCULATED BY USING 10'X12' STRETCH.

**LAKE CORPUS CHRISTI STATE PARK ROADWAY SUMMARY**



CONT	SECT	JOB	HIGHWAY
0916	28	071	PR 25A
DIST	COUNTY		SHEET NO.
CRP	SAN PATRICIO		14

DATE: 1/13/2023 5:15:20 PM  
 FILE: pw://txdot.projectwiseonline.com:txdot4/Document/16 - CRP/Design Projects/091628071/4 - Design/Plan Set/5. Drainage/LAKE CC DRAINAGE DETAILS

DWG: [ ]  
 CHK: [ ]  
 DWF: [ ]  
 CKE: [ ]

CSJ: 0916-28-071 LAKE CORPUS CHRISTI - DRAINAGE QUANTITIES							
LOCATION	EXISTING STRUCTURE	PROPOSED STRUCTURE	LENGTH	400	464	467	496
				6012	6005	6388	6007
				CUT AND RESTORING PAV	RC PIPE (CL III) (24IN)	SET (TY II) (24IN) (RCP) (3:1) (C)	REMOVE STR (PIPE)
			LF	SY	LF	EA	LF
PARK ROAD A	3x STEEL PIPE 24"	3X RCP 24" W/ SET (3:1)	36	46	108	6	108
<b>CSJ: 0916-28-071 TOTALS:</b>				<b>46</b>	<b>108</b>	<b>6</b>	<b>108</b>

APPROXIMATE LOCATION OF DRAINAGE STRUCTURE: 610622.42 m E, 3104740.22 m E (ZONE 14R).

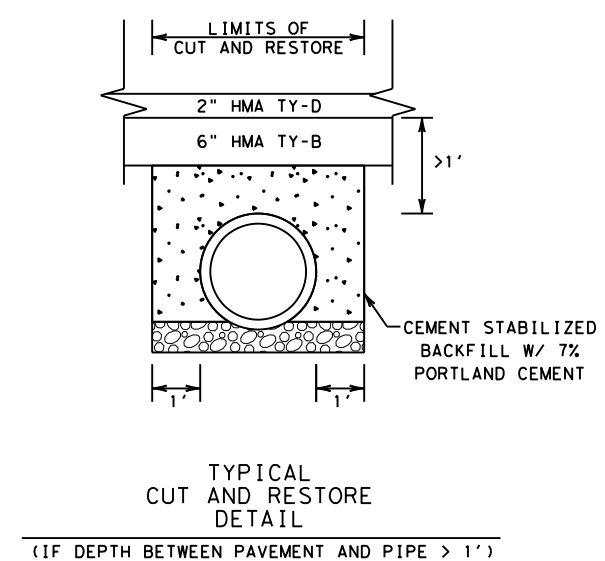
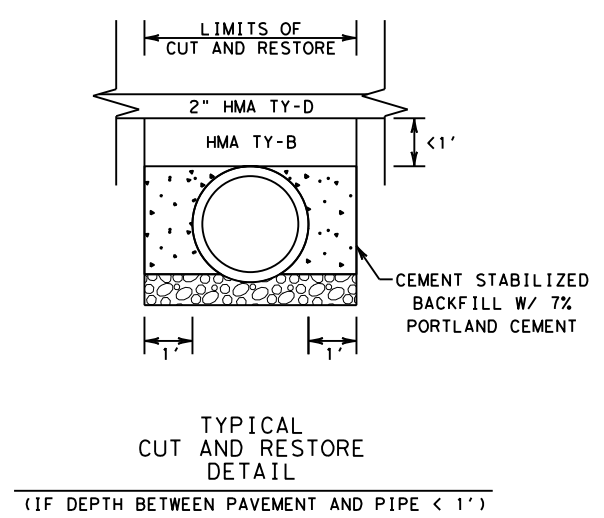

01/13/2023  
**LAKE CORPUS CHRISTI STATE PARK DRAINAGE SUMMARY**

SHEET 1 OF 1

CONT	SECT	JOB	HIGHWAY
0916	28	071	PR 25A
DIST	COUNTY		SHEET NO.
CRP	SAN PATRICIO		15

DATE: 1/13/2023 5:15:43 PM  
 FILE: p:\t\dot\project\wiseonline.com\t\dot\4\Documents\16 - CRP\Design Projects\091628071\4 - Design\Plan Set\1. General\LAKE CORPUS CHRISTI\LAKE CORPUS CHRISTI\SUMMARY & DETAIL SHEET

CSJ: 0916-28-071 LAKE CORPUS CHRISTI - PARKING LOTS QUANTITIES						
LOT ID	WIDTH	LENGTH	AREA	316	316	3076
				6001	6430	6042
				ASPH (MULTI OPTION)	AGGR (TY-PB GR-3 OR TY-PB GR-3S) (SAC-B)	D-GR HMA TY-D SAC-B PG70-22
	LF	LF	SY	GAL	CY	TON
PARKING 1	90	45	580	203	6	48
PARKING 2	60	20	134	47	2	12
PARKING 3	50	20.5	114	40	2	10
PARKING 4	60	22.5	150	53	2	13
PARKING 5	80	20	178	63	2	15
PARKING 6	60	20	134	47	2	12
PARKING 7	145	20	355	125	4	30
PARKING 8	62	21	145	51	2	12
PARKING 9	80	24	214	75	2	18
PARKING 10	363	19.5	795	279	8	66
PARKING 11	41	24	110	39	1	10
<b>TOTALS:</b>			<b>2909</b>	<b>1022</b>	<b>33</b>	<b>246</b>

CSJ: 0916-28-071 LAKE CORPUS CHRISTI - BIRD'S NEST SHELTER DRIVEWAYS LOTS								
LOT ID	LENGTH	THROAT	WIDTH	AREA	316	316	3076	5008
					6001	6430	6042	6002
					ASPH (MULTI OPTION)	AGGR (TY-PB GR-3 OR TY-PB GR-3S) (SAC-B)	D-GR HMA TY-D SAC-B PG70-22	MOVE AND RESET PRECAST CONC WHEEL STOPS
	LF	LF	LF	SY	GAL	CY	TON	EA
1	46		36	66	24	1	6	1
2	38		35	73	26	1	7	1
3	42		12	70	25	1	6	1
4	16		50	53	19	1	5	1
5	55		12	74	26	1	7	1
6 & 7	42	12	54	134	47	2	12	4
8 & 9	44	12	55	167	59	2	14	4
10 & 11	50	12	60	189	67	2	16	4
12 & 13	55	12	61	189	67	2	16	4
14 & 15	56	12	61	212	75	2	18	4
16	62	12	16	200	70	2	17	2
17 & 18	55	16	59	189	67	2	16	4
19 & 20	62	14	56	180	63	2	15	4
21 & 22	46	17	57	187	66	2	16	4
23 & 24	66	12	50	184	65	2	16	4
25	25	12	12	57	20	1	5	1
<b>TOTALS:</b>				<b>2224</b>	<b>786</b>	<b>26</b>	<b>192</b>	<b>44</b>

CSJ: 0916-28-071 LAKE CORPUS CHRISTI MISC PARKING AREAS					
LOCATION	NO. OF LOTS	AREA	316	316	3076
			6001	6430	6042
			ASPH (MULTI OPTION)	AGGR (TY-PB GR-3 OR TY-PB GR-3S) (SAC-B)	D-GR HMA TY-D SAC-B PG70-22
		SY	GAL	CY	TON
SUNSET CIRCLE	3	404	142	4	34
GREEN JAY LANE	3	362	127	4	30
CATFISH COVE	2	602	211	6	50
<b>TOTALS:</b>		<b>1368</b>	<b>480</b>	<b>14</b>	<b>114</b>

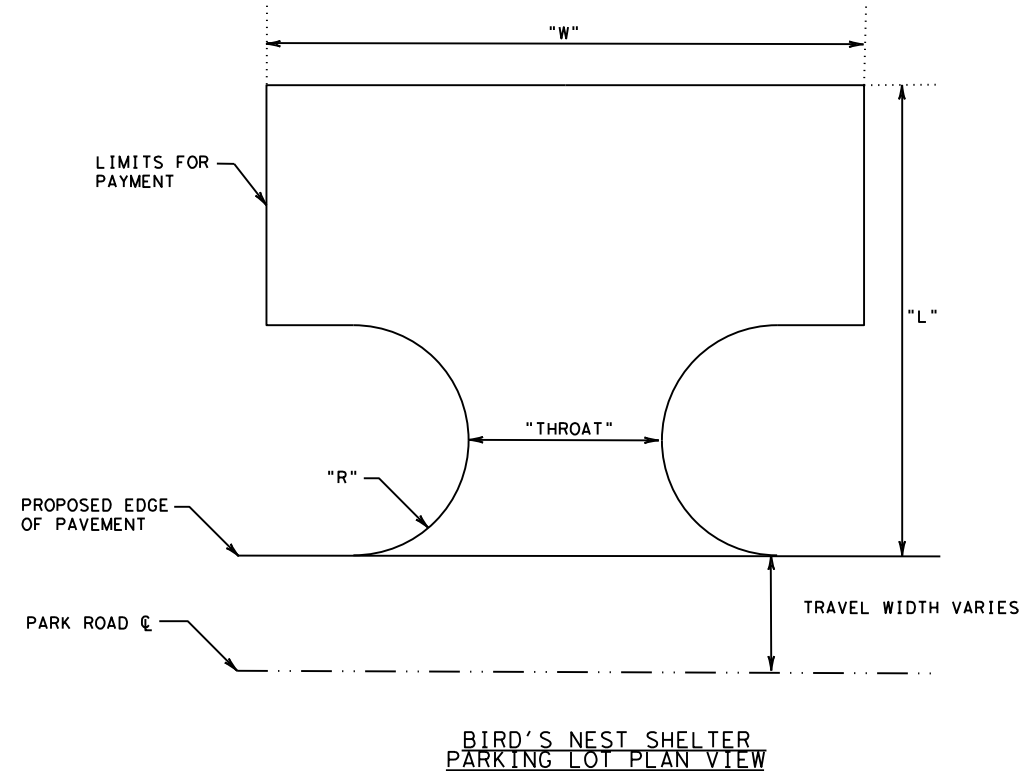
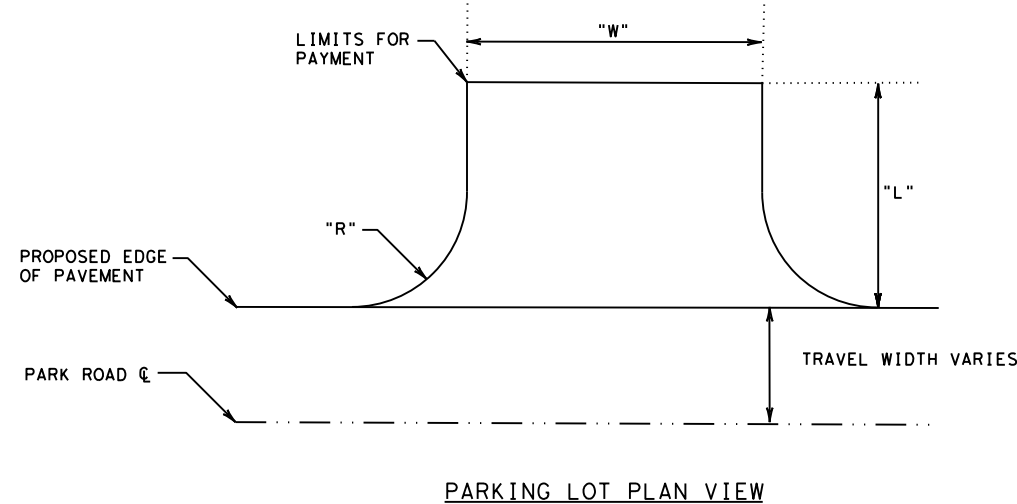

NOTE: TYPICAL RADIUS IS 10(FT)

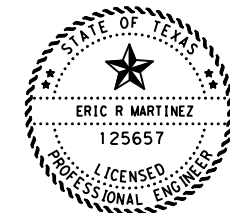

*E. Martinez, P.E.*

01/13/2023

**LAKE CORPUS CHRISTI  
 STATE PARK  
 PARKING LOTS  
 SUMMARY**

SHEET 1 OF 1

CONT	SECT	JOB	HIGHWAY
0916	28	071	PR 25A
DIST	COUNTY		SHEET NO.
CRP	SAN PATRICIO		16

DATE: 1/13/2023 5:15:55 PM  
 FILE: pw://twdot.projectwiseonline.com:txdot/Projects/091628071/4 - CRP/Design Projects/091628071/4 - Design/Plan Set/1. General/LAKE CORPUS CHRISTI/LAKE CORPUS PARKING SUMMARY & DETAIL

CSJ: 0916-28-071 LAKE CORPUS CHRISTI - RV LOTS QUANTITIES											
LOCATION	TYPE	WIDTH	LENGTH	RADIUS	NO. OF LOTS	AREA	316	316	3076	5008	
							6001	6430	6042	6002	
							ASPH (MULTI OPTION)	AGGR (TY-PB GR-3 OR TY-PB GR-3S) (SAC -B)	D-GR HMA TY-D SAC-B PG70-22	MOVE AND RESET PRECAST CONC WHEEL STOPS	
						SY	GAL	CY	TON	EA	
JAVELINA CAMPSITE	PULL-THROUGH	12	100		25	3334	1167	31	276		
CATFISH COVE CAMPSITE	BACK-IN	14	40	10	35	2205	772	21	182	35	
OPOSSUM BEND	PULL-THROUGH	12	100		23	3067	1074	28	254		
MESQUITE CAMPING	BACK-IN	14	40	10	25	1575	552	15	130	25	
					<b>TOTALS:</b>	<b>108</b>	<b>10181</b>	<b>3565</b>	<b>95</b>	<b>842</b>	<b>60</b>

NOTE: TYPICAL DIMENSIONS SHOULD BE FIELD VERIFIED.

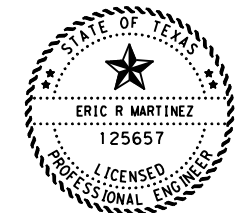
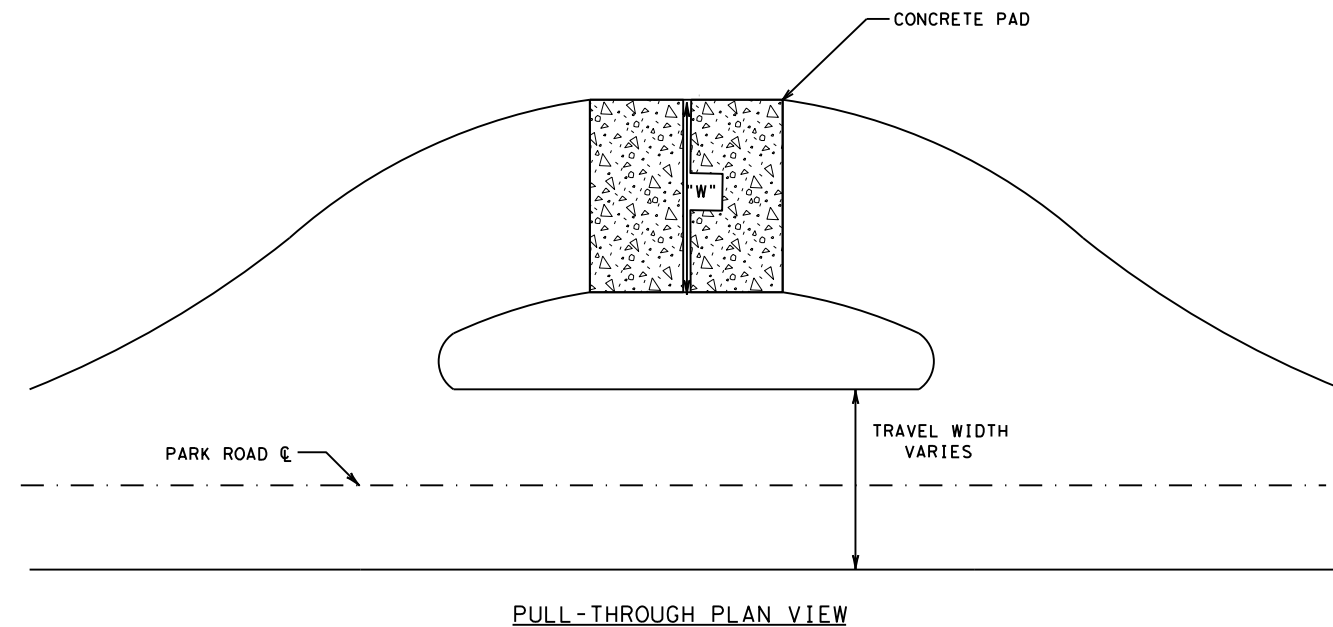
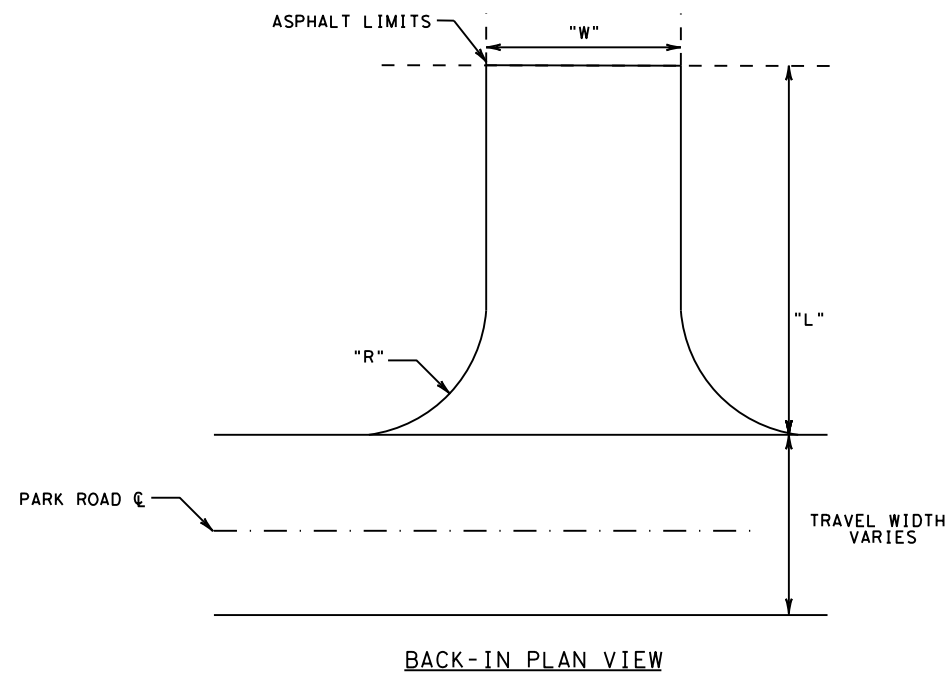

*Eric R. Martinez*

01/13/2023

**LAKE CORPUS CHRISTI  
 STATE PARK  
 RV PARKING SUMMARY**

SHEET 1 OF 1

CONT	SECT	JOB	HIGHWAY
0916	28	071	PR 25A
DIST	COUNTY		SHEET NO.
CRP	SAN PATRICIO		17

DATE: 1/31/2023 8:51:55 AM  
 FILE: pw://twdot.projectwiseonline.com:txdot4/Documents/16 - CRP/Design Projects/091628071/4 - Design/Plan Set/1. General/LAKE CORPUS CHRISTI/LAKE CORPUS CHRISTI SURFACE DETA [Dr. SUMMARY] & DETA

CSJ: 0916-28-071 LAKE CORPUS CHRISTI - SURFACE DETAIL QUANTITIES									
LOCATION	NO. OF PARKING LOTS	666	666	666	666	668	668	672	5008
		6041	6302	6317	6356	6055	6085	6008	6002
		REFL PAV MRK TY I (W) 12" (SLD) (090MIL)	RE PM W/RET REQ TY I (W) 4" (SLD) (090MIL)	RE PM W/RET REQ TY I (Y) 6" (BRK) (090 MIL)	REFL PAV MRK TY II (R&W) 6" (FIRE LANE)	RE PM TY B (ACC PRK) (BL&WH) (W/B ORDR) LG	PREFAB PAV MRK TY C (W) (WORD)	REFL PAV MRKR TY I-C	MOVE AND RESET PRECAST CONC WHEEL STOPS
		LF	LF	LF	LF	EA	EA	EA	EA
PARK ROAD 25	11		2295	758		3	6		108
HQ AREA	3		350			1	2		10
JAVALINA CAMPSITE*	1	36	105	694				12	1
CATFISH COVE	2		325						13
BIRD'S NEST SHELTER	2		305	1204					18
CAVE SWALLOW COVE	2		305			1	2		14
GREEN JAY LANE	3		320	200					19
SUNSET CIRCLE	3		300	200					18
MESQUITE CAMPSITE	9		2390		50				25
BASS POINT	5		400						28
<b>CSJ: 0916-28-071</b>	<b>TOTALS:</b>	<b>36</b>	<b>7095</b>	<b>3056</b>	<b>50</b>	<b>5</b>	<b>10</b>	<b>12</b>	<b>254</b>

**NOTES:**

- ADA COMPLIANT (ACCESSIBLE, AC) PARKING SPACES WIDTH'S ARE 8' WHILE ADJACENT AISLE SHALL BE 5' TO COMPLY WITH PM(P)-21 STANDARD
  - CONVENTIONAL PARKING SPACES SHALL BE 10' WIDE IF SPACE ALLOWS
  - REFER TO TEXAS PARKS & WILDLIFE DEPARTMENT DESIGN STANDARDS FOR ROADS AND PARKING IF NEEDED.
- \* REFER TO LAKE CORPUS CHRISTI LAYOUT SHEET 1, FOR DETAILS CONCERNING NEW CONSTRUCTION AT JAVALINA CAMPSITE.

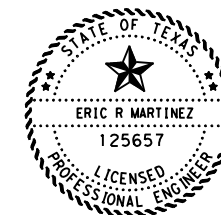
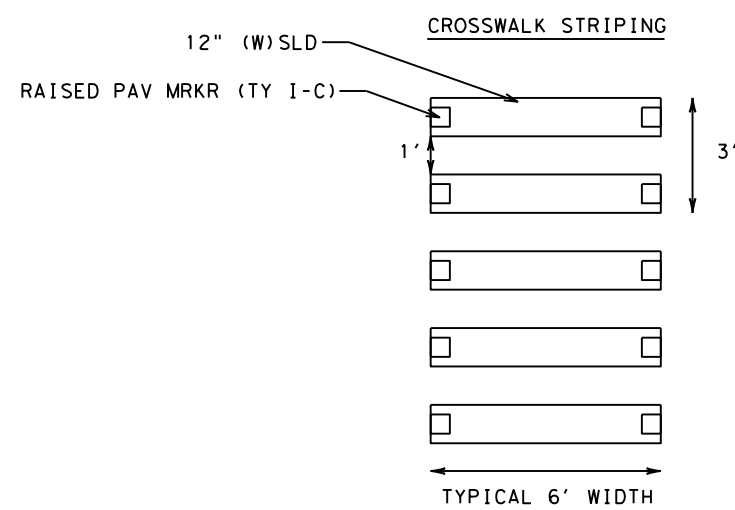
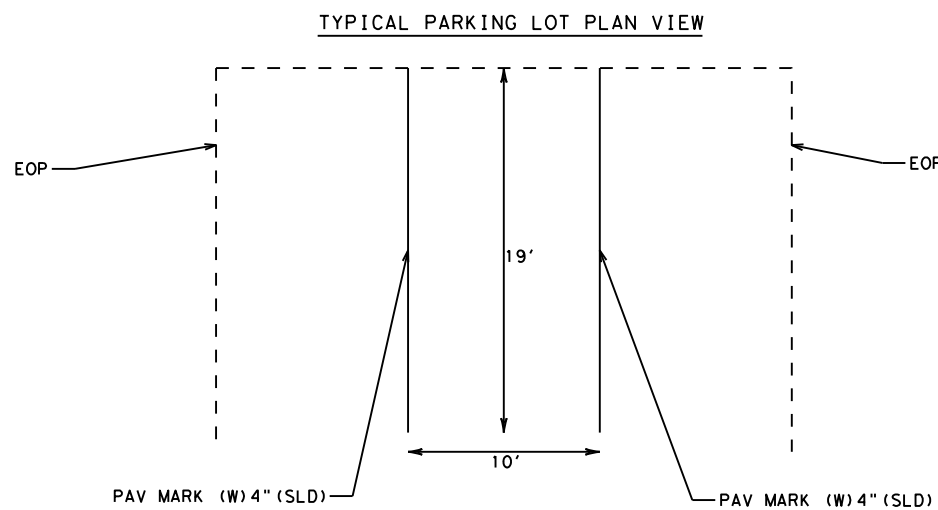

*Eric R. Martinez*

02/06/2023

**LAKE CORPUS CHRISTI  
STATE PARK  
SURFACE DETAILS  
SUMMARY**

SHEET 1 OF 1



CONT	SECT	JOB	HIGHWAY
0916	28	071	PR 25A
DIST	COUNTY	SHEET NO.	
CRP	SAN PATRICIO	18	

DATE: 1/13/2023 5:16:21 PM  
 FILE: pw://txdot.projectwiseonline.com:txdot4/Documents/16 - CRP/Design Projects/091628071/4 - Design/Plan Set/2. TCP/SEQUENCE OF CONSTRUCTION

## GENERAL NOTES FOR THE CONSTRUCTION SEQUENCE

1. ALL BEGINNING AND ENDING BARRICADES AND SIGNS ARE TO REMAIN IN PLACE FOR THE DURATION OF THE PROJECT.
2. ALL SIGNS, BARRICADES AND PAVEMENT MARKINGS SHALL CONFORM WITH THE BC STANDARD SHEETS, TCP SHEETS, AND THE LATEST EDITION OF THE "TEXAS MANUAL ON UNIFORM TRAFFIC CONTROL DEVICES".
3. CW20-1D, G20-2A & EITHER G20-1bL or G20-1bR SIGNS WILL BE REQUIRED AT ALL PUBLIC ROADS, AND INTERSECTIONS WITHIN LIMITS. (G20-2A) SIGNS MAY BE MOUNTED ON BACK OF CW20-1D, SEE BC(2)-21.
4. THE CONTRACTOR SHALL PROVIDE FOR SAFE AND CONVENIENT INGRESS AND EGRESS TO ABUTTING PROPERTY HIGHWAY, PUBLIC ROAD, AND STREET CROSSING FOR ALL VEHICLES. IT WILL BE THE RESPONSIBILITY OF THE CONTRACTOR TO MAINTAIN ALL CROSSINGS IN A SAFE AND PASSABLE CONDITION.
5. FOR SPACING OF SIGNS AND BARRICADES SEE "BC" & "TCP" STANDARD SHEETS OR AS DIRECTED BY THE ENGINEER.
6. THE CONTRACTOR MAY BE REQUIRED TO FURNISH ADDITIONAL BARRICADES, SIGNS, AND WARNING LIGHTS TO MAINTAIN TRAFFIC AND PROMOTE MOTORISTS SAFETY. ANY SUCH ADDITIONAL SIGNS AND BARRICADES SHALL BE CONSIDERED SUBSIDIARY TO ITEM 502.
7. ALL SIGNS SHALL BE NEW OR FRESHLY PAINTED, AND KEPT CLEAN FOR THE DURATION OF THE PROJECT.
8. ALL TRAFFIC BARRELS & EDGE LINE CHANNELIZERS SHALL BE USED IN ACCORDANCE WITH THE PLANS AND MANUFACTURER'S RECOMMENDATIONS AND SHALL HAVE A 7" PRISMATIC REFLECTOR UNIT, AS APPROVED BY THE ENGINEER. ALL MATERIALS SHALL BE CONSIDERED SUBSIDIARY TO ITEM 502.
9. SIGNS, PAVEMENT MARKINGS, CHANNELIZING DEVICES, AND OTHER TRAFFIC CONTROL DEVICES THAT ARE INCONSISTENT WITH INTENDED TRAVEL PATHS THROUGH THE PROJECT AREA SHALL BE REMOVED IMMEDIATELY.
10. ALL TRAFFIC CONTROL DEVICES SHALL BE REMOVED WHEN NO LONGER NEEDED. WHEN WORK IS SUSPENDED FOR SHORT TIME PERIOD, ADVANCED WARNING SIGNS THAT ARE NO LONGER APPROPRIATE SHALL BE REMOVED FROM THE PROJECT AREA.
11. THE CONTRACTOR WILL BE RESPONSIBLE FOR MARKING THE LOCATION OF ALL TRAFFIC CONTROL STRIPING AND PERMANENT STRIPING AS DIRECTED BY THE ENGINEER.
12. SHORT TERM FLEXIBLE REFLECTIVE ROADWAY TABS SHALL BE USED TO SIMULATE PERMANENT STRIPING FOR A MAXIMUM OF 14 DAYS. PERMANENT STRIPING SHALL BE DONE IN ACCORDANCE WITH ALL APPLICABLE STANDARDS. THE CONTRACTOR SHOULD BE AWARE, DEPENDING ON THE SEQUENCE OF CONSTRUCTION, THE STRIPING CREW MAY HAVE SEVERAL MOVE-INS. ALL SHORT TERM FLEXIBLE REFLECTIVE ROADWAY TABS SHALL BE REPLACED AS NEEDED WITHIN THAT 14 DAY PERIOD AT THE CONTRACTOR'S EXPENSE.
13. IN AREAS WHERE ROADWAY IS BEING WORKED ADJACENT TO UNWORKED ROADWAY A 150' LONG TRANSITION WILL BE MADE TO ACCOUNT FOR ANY TRANSVERSE VERTICAL DROP OFFS. THE MATERIAL USED SHALL BE FLEX BASE OR ANY OTHER SUITABLE MATERIAL AS APPROVED BY THE ENGINEER. SEE PROFILE TRANSITION DETAIL.

### UNEVEN LANES

1. ANY VERTICAL OR NEAR VERTICAL LONGITUDINAL FACE EXCEEDING 1 INCH IN HEIGHT IN THE PAVEMENT SURFACE OPEN TO TRAFFIC AT THE END OF THE WORK DAY SHALL BE SLOPPED A MINIMUM 3:1. TRANSVERSE FACES THAT ARE PRESENT AT THE END OF THE WORK DAY SHALL BE TAPERED IN A MANNER ACCEPTABLE TO THE ENGINEER.
2. SIGNING FOR UNEVEN LANES (CW8-11) SHOULD BE INSTALLED IN ADVANCE TO THE CONDITION AND REPEATED EVERY 1 MILE. SIGNS INSTALLED ALONG THE UNEVEN LANE CONDITION SHOULD BE SUPPLEMENTED WITH THE NEXT XX MILES SIGN (CW7-3aP) OR ADVISORY SPEED SIGN (CW13-P). SEE WZ(UL)-13 FOR ADDITIONAL DETAILS.
3. UNEVEN LANE SIGNS (CW8-11) SHALL BE ERECTED ON BOTH ENDS ON THE AREA WHERE THERE IS A DIFFERENCE IN ELEVATION BETWEEN ADJACENT LANES GREATER THAN ONE INCH.

### PAVEMENT DROP-OFF

1. MAXIMUM ELEVATION DROP-OFF ON PAVEMENT EDGE SHALL NOT EXCEED 1 INCH WHEN TRAFFIC IS ALLOWED ADJACENT TO THE DROP-OFF. THE SLOPE MUST BE COMPACTED MATERIAL CAPABLE OF SUPPORTING VEHICLES. THIS WORK WILL NOT BE PAID FOR DIRECTLY BUT SHALL BE CONSIDERED SUBSIDIARY TO THE VARIOUS BID ITEMS.
2. SIGNING FOR PAVEMENT DROP-OFF (CW8-9aT) SHOULD BE INSTALLED IN ADVANCE OF THE CONDITION AND REPEATED EVERY 1 MILE. SIGNS INSTALLED ALONG THE PAVEMENT EDGE SHOULD BE SUPPLEMENTED WITH THE NEXT XX MILES SIGN (CW7-3aP) OR ADVISORY SPEED SIGN (CW13-P).

## SUGGESTED SEQUENCE OF CONSTRUCTION

1. PLACE PERIMETER BARRICADES AT FIRST WORK LOCATION IN ACCORDANCE WITH BC AND TCP STANDARD SHEETS.
  2. COMPLETE DRAINAGE AND ROADWAY WORK DETAILED IN THE PLANS UTILIZING DAILY SINGLE LANE CLOSURES IN ACCORDANCE WITH TCP STANDARD SHEETS. UTILIZE TRAFFIC CONTROL STANDARDS THAT MINIMIZE CLOSURES OF PARK AREAS.
  3. COMPLETE FINAL PAVEMENT MARKING AND CLEANUP LOCATION LIMITS
  4. COMPLETE ALL WORK IN ONE LOCATION BEFORE PROCEEDING TO THE NEXT LOCATION UNLESS APPROVED BY THE ENGINEER.
- REPEAT STEPS 1-3 AT EACH OF THE REMAINING LOCATIONS.

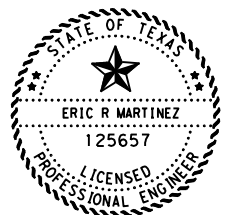

*Eric R. Martinez*

01/13/2023

### SUGGESTED SEQUENCE OF CONSTRUCTION

SHEET 1 OF 1

CONT	SECT	JOB	HIGHWAY
0916	28	071	PR 25A
DIST	COUNTY		SHEET NO.
CRP	SAN PATRICIO		19







DATE: 1/13/2023 5:16:48 PM  
 FILE: //txdot.projectwiseonline.com:txdot14/Documents/16 - CRP/Design Projects/0916280114 - Design/Plan Set/13 - Standards/BC(1)-21.dgn  
 No. warranty of any kind is made by TxDOT for any purpose whatsoever. TxDOT assumes no responsibility for the conversion of this information into any other format or for the use of this information in any other project.

**BARRICADE AND CONSTRUCTION (BC) STANDARD SHEETS GENERAL NOTES:**

- The Barricade and Construction Standard Sheets (BC sheets) are intended to show typical examples for placement of temporary traffic control devices, construction pavement markings, and typical work zone signs. The information contained in these sheets meet or exceed the requirements shown in the "Texas Manual on Uniform Traffic Control Devices" (TMUTCD).
- The development and design of the Traffic Control Plan (TCP) is the responsibility of the Engineer.
- The Contractor may propose changes to the TCP that are signed and sealed by a licensed professional engineer for approval. The Engineer may develop, sign and seal Contractor proposed changes.
- The Contractor is responsible for installing and maintaining the traffic control devices as shown in the plans. The Contractor may not move or change the approximate location of any device without the approval of the Engineer.
- Geometric design of lane shifts and detours should, when possible, meet the applicable design criteria contained in manuals such as the American Association of State Highway and Transportation Officials (AASHTO), "A Policy on Geometric Design of Highways and Streets," the TxDOT "Roadway Design Manual" or engineering judgment.
- When projects abut, the Engineer(s) may omit the END ROAD WORK, TRAFFIC FINES DOUBLE, and other advance warning signs if the signing would be redundant and the work areas appear continuous to the motorists. If the adjacent project is completed first, the Contractor shall erect the necessary warning signs as shown on these sheets, the TCP sheets or as directed by the Engineer. The BEGIN ROAD WORK NEXT X MILES sign shall be revised to show appropriate work zone distance.
- The Engineer may require duplicate warning signs on the median side of divided highways where median width will permit and traffic volumes justify the signing.
- All signs shall be constructed in accordance with the details found in the "Standard Highway Sign Designs for Texas," latest edition. Sign details not shown in this manual shall be shown in the plans or the Engineer shall provide a detail to the Contractor before the sign is manufactured.
- The temporary traffic control devices shown in the illustrations of the BC sheets are examples. As necessary, the Engineer will determine the most appropriate traffic control devices to be used.
- Where highway construction or maintenance work is being undertaken, other than mobile operations as defined by the Texas Manual on Uniform Traffic Control Devices, CSJ limit signs are required. CSJ limit signs are shown on BC(2). The OBEY WARNING SIGNS STATE LAW sign, STAY ALERT TALK OR TEXT LATER and the WORK ZONE TRAFFIC FINES DOUBLE sign with plaque shall be erected in advance of the CSJ limits. The BEGIN ROAD WORK NEXT X MILES, CONTRACTOR and END ROAD WORK signs shall be erected at or near the CSJ limits. For mobile operations, CSJ limit signs are not required.
- Traffic control devices should be in place only while work is actually in progress or a definite need exists.
- The Engineer has the final decision on the location of all traffic control devices.
- Inactive equipment and work vehicles, including workers' private vehicles must be parked away from travel lanes. They should be as close to the right-of-way line as possible, or located behind a barrier or guardrail, or as approved by the Engineer.

**WORKER SAFETY NOTES:**

- Workers on foot who are exposed to traffic or to construction equipment within the right-of-way shall wear high-visibility safety apparel meeting the requirements of ISEA "American National Standard for High-Visibility Apparel," or equivalent revisions, and labeled as ANSI 107-2004 standard performance for Class 2 or 3 risk exposure. Class 3 garments should be considered for high traffic volume work areas or night time work.
- Except in emergency situations, flagger stations shall be illuminated when flagging is used at night.

**COMPLIANT WORKZONE TRAFFIC CONTROL DEVICES**

- Only pre-qualified products shall be used. The "Compliant Work Zone Traffic Control Devices List" (CWZTCD) describes pre-qualified products and their sources.
- Work zone traffic control devices shall be compliant with the Manual for Assessing safety Hardware (MASH).

<b>THE DOCUMENTS BELOW CAN BE FOUND ON-LINE AT</b> <a href="http://www.txdot.gov">http://www.txdot.gov</a>
COMPLIANT WORK ZONE TRAFFIC CONTROL DEVICES LIST (CWZTCD)
DEPARTMENTAL MATERIAL SPECIFICATIONS (DMS)
MATERIAL PRODUCER LIST (MPL)
ROADWAY DESIGN MANUAL - SEE "MANUALS (ONLINE MANUALS)"
STANDARD HIGHWAY SIGN DESIGNS FOR TEXAS (SHSD)
TEXAS MANUAL ON UNIFORM TRAFFIC CONTROL DEVICES (TMUTCD)
TRAFFIC ENGINEERING STANDARD SHEETS

SHEET 1 OF 12

 Texas Department of Transportation		Traffic Safety Division Standard	
<b>BARRICADE AND CONSTRUCTION GENERAL NOTES AND REQUIREMENTS</b>			
<b>BC (1) - 21</b>			
FILE: bc-21.dgn	DN: TxDOT	CR: TxDOT	DW: TxDOT
© TxDOT November 2002	CONT	SECT	JOB
	0916	28	071
			PR 25A
REVISIONS	DIST	COUNTY	SHEET NO.
4-03 7-13			
9-07 8-14			
5-10 5-21	CRP	SAN PATRICIO	22

DISCLAIMER: The use of this standard is governed by the "Texas Engineering Practice Act". No warranty of any kind is made by TxDOT for any purpose whatsoever. TxDOT assumes no responsibility for the conversion of units or the accuracy of any information or data contained herein.

**TYPICAL LOCATION OF CROSSROAD SIGNS**

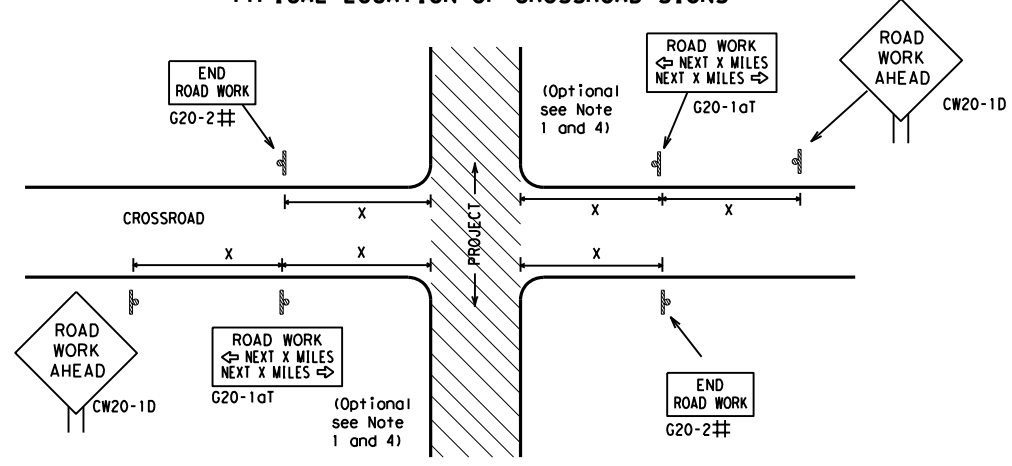

- # May be mounted on back of "ROAD WORK AHEAD" (CW20-1D) sign with approval of Engineer. (See note 2 below)
- The typical minimum signing on a crossroad approach should be a "ROAD WORK AHEAD" (CW20-1D) sign and a (G20-2) "END ROAD WORK" sign, unless noted otherwise in plans.
  - The Engineer may use the reduced size 36" x 36" ROAD WORK AHEAD (CW20-1D) sign mounted back to back with the reduced size 36" x 18" "END ROAD WORK" (G20-2) sign on low volume crossroads (see Note 4 under "Typical Construction Warning Sign Size and Spacing"). See the "Standard Highway Sign Designs for Texas" manual for sign details. The Engineer may omit the advance warning signs on low volume crossroads. The Engineer will determine whether a road is low volume as per TMUTCD Part 5. This information shall be shown in the plans.
  - Based on existing field conditions, the Engineer/Inspector may require additional signs such as FLAGGER AHEAD, LOOSE GRAVEL, or other appropriate signs. When additional signs are required, these signs will be considered part of the minimum requirements. The Engineer/Inspector will determine the proper location and spacing of any sign not shown on the BC sheets, Traffic Control Plan sheets or the Work Zone Standard Sheets.
  - The "ROAD WORK NEXT X MILES" (G20-1aT) sign shall be required at high volume crossroads to advise motorists of the length of construction in either direction from the intersection. The Engineer will determine whether a roadway is considered high volume.
  - Additional traffic control devices may be shown elsewhere in the plans for higher volume crossroads.
  - When work occurs in the intersection area, appropriate traffic control devices, as shown elsewhere in the plans or as determined by the Engineer/Inspector, shall be in place.

**T-INTERSECTION**

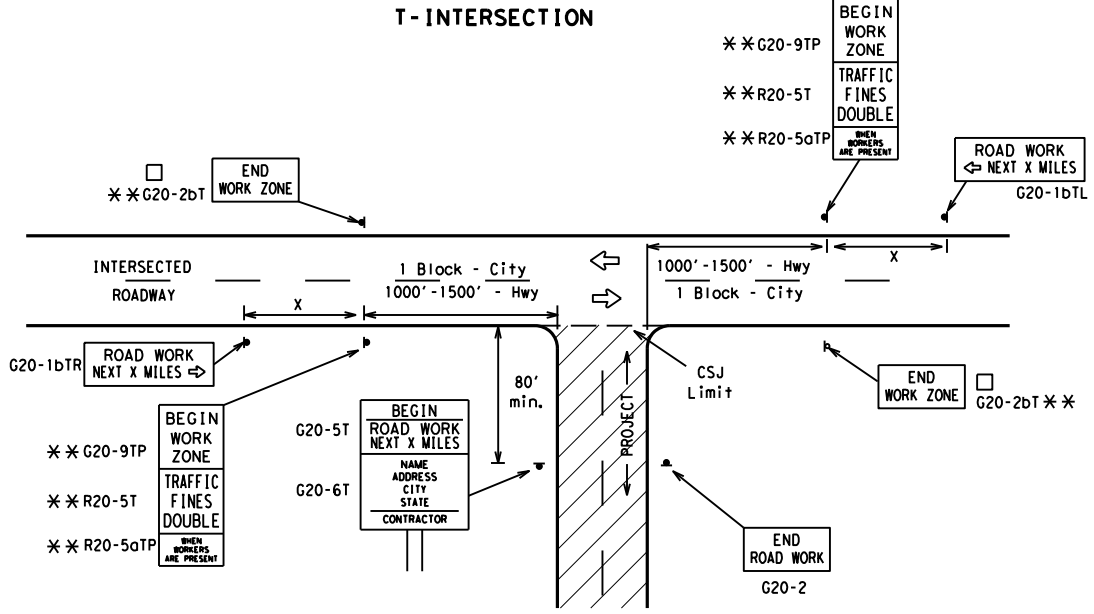

**CSJ LIMITS AT T-INTERSECTION**

- The Engineer will determine the types and location of any additional traffic control devices, such as a flagger and accompanying signs, or other signs, that should be used when work is being performed at or near an intersection.
- If construction closes the road at a T-intersection, the Contractor shall place the "CONTRACTOR NAME" (G20-6T) sign behind the Type 3 Barricades for the road closure (see BC(10) also). The "ROAD WORK NEXT X MILES" left arrow (G20-1bTL) and "ROAD WORK NEXT X MILES" right arrow (G20-1bTR) signs shall be replaced by the detour signing called for in the plans.

**TYPICAL CONSTRUCTION WARNING SIGN SIZE AND SPACING<sup>1,5,6</sup>**

Sign Number or Series	SIZE		SPACING	
	Conventional Road	Expressway/Freeway	Posted Speed MPH	Sign Δ Spacing "x" Feet (Apprx.)
CW20 <sup>4</sup>	48" x 48"	48" x 48"	30	120
CW21			35	160
CW22			40	240
CW23			45	320
CW25			50	400
CW1, CW2, CW7, CW8, CW9, CW11, CW14	36" x 36"	48" x 48"	55	500 <sup>2</sup>
CW3, CW4, CW5, CW6, CW8-3, CW10, CW12	48" x 48"	48" x 48"	60	600 <sup>2</sup>
			65	700 <sup>2</sup>
			70	800 <sup>2</sup>
			75	900 <sup>2</sup>
			80	1000 <sup>2</sup>
			*	* <sup>3</sup>

\* For typical sign spacings on divided highways, expressways and freeways, see Part 6 of the "Texas Manual on Uniform Traffic Control Devices" (TMUTCD) typical application diagrams or TCP Standard Sheets.

Δ Minimum distance from work area to first Advance Warning sign nearest the work area and/or distance between each additional sign.

**GENERAL NOTES**

- Special or larger size signs may be used as necessary.
- Distance between signs should be increased as required to have 1500 feet advance warning.
- Distance between signs should be increased as required to have 1/2 mile or more advance warning.
- 36" x 36" "ROAD WORK AHEAD" (CW20-1D) signs may be used on low volume crossroads at the discretion of the Engineer as per TMUTCD Part 5. See Note 2 under "Typical Location of Crossroad Signs".
- Only diamond shaped warning sign sizes are indicated.
- See sign size listing in "TMUTCD", Sign Appendix or the "Standard Highway Sign Designs for Texas" manual for complete list of available sign design sizes.

**WORK AREAS IN MULTIPLE LOCATIONS WITHIN CSJ LIMITS**

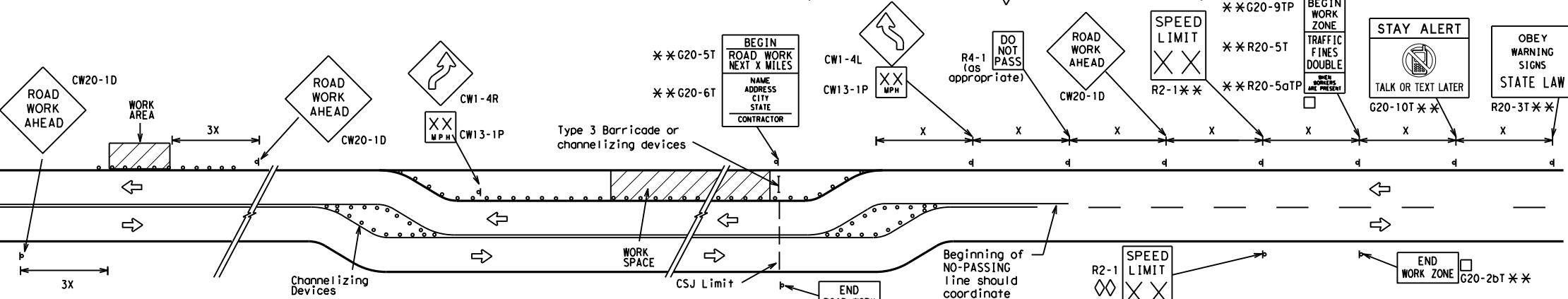

When extended distances occur between minimal work spaces, the Engineer/Inspector should ensure additional "ROAD WORK AHEAD" (CW20-1D) signs are placed in advance of these work areas to remind drivers they are still within the project limits. See the applicable TCP sheets for exact location and spacing of signs and channelizing devices.

**SAMPLE LAYOUT OF SIGNING FOR WORK BEGINNING DOWNSTREAM OF THE CSJ LIMITS**

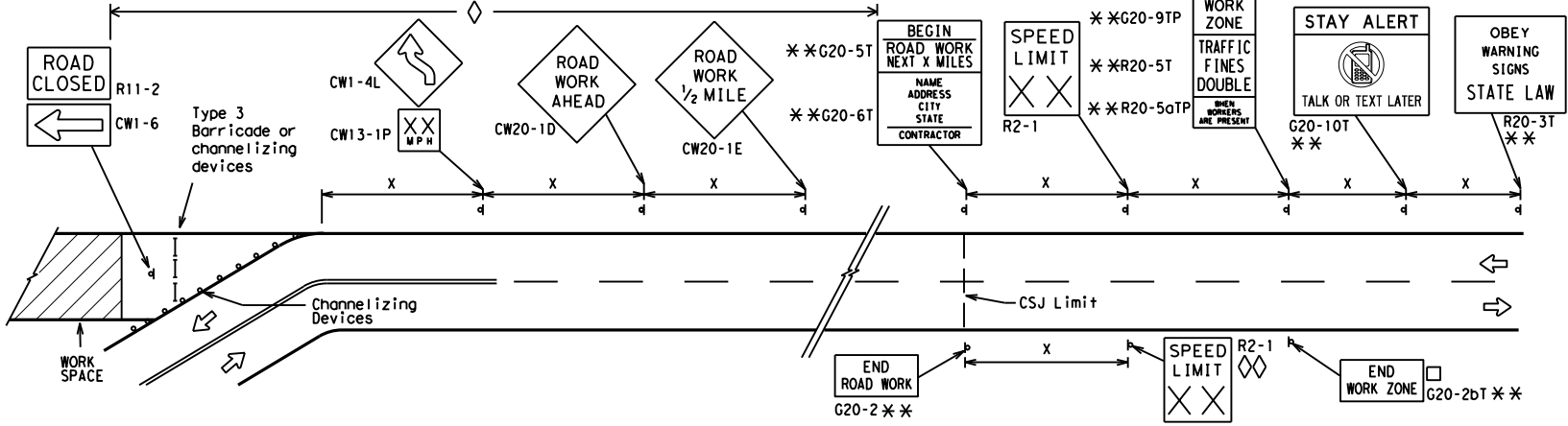

**SAMPLE LAYOUT OF SIGNING FOR WORK BEGINNING AT THE CSJ LIMITS**

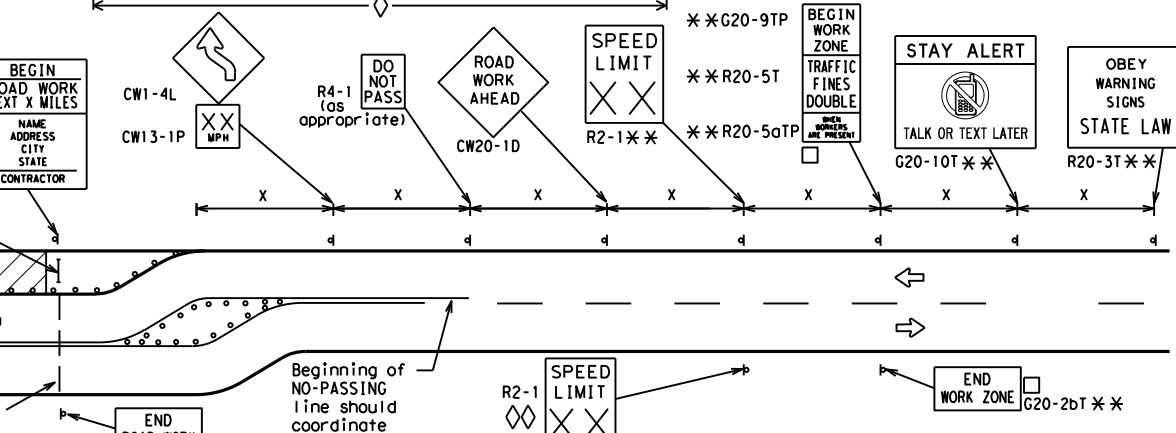

**NOTES**

- The Contractor shall determine the appropriate distance to be placed on the G20-1 series signs and "BEGIN ROAD WORK NEXT X MILES" (G20-5T) sign for each specific project. This distance shall replace the "x" and shall be rounded to the nearest whole mile with the approval of the Engineer. No decimals shall be used.
- The "BEGIN WORK ZONE" (G20-9TP) and "END WORK ZONE" (G20-2bT) shall be used as shown on the sample layout when advance signs are required outside the CSJ Limits. They inform the motorist of entering or leaving a part of the work zone lying outside the CSJ Limits where traffic fines may double if workers are present.
  - CSJ limit signing is required for highway construction and maintenance work, with the exception of mobile operations.
  - Area for placement of "ROAD WORK AHEAD" (CW20-1D) sign and other signs or devices as called for on the Traffic Control Plan.
  - Contractor will install a regulatory speed limit sign at the end of the work zone.

**LEGEND**

—	Type 3 Barricade
○ ○ ○	Channelizing Devices
■	Sign
X	See Typical Construction Warning Sign Size and Spacing chart or the TMUTCD for sign spacing requirements.

SHEET 2 OF 12



**BARRICADE AND CONSTRUCTION PROJECT LIMIT**

**BC(2)-21**

FILE: bc-21.dgn	DN: TxDOT	CK: TxDOT	DW: TxDOT	CK: TxDOT
© TxDOT November 2002	CONT	SECT	JOB	HIGHWAY
REVISIONS	0916	28	071	PR 25A
9-07 8-14	DIST	COUNTY	SHEET NO.	
7-13 5-21	CRP	SAN PATRICIO	23	



DISCLAIMER: The use of this standard is governed by the "Texas Engineering Practice Act". No warranty of any kind is made by TxDOT for any purpose whatsoever. TxDOT assumes no responsibility for the conversion of this standard to other formats or for incorrect results or damages resulting from its use.

DATE: 1/13/2023 5:16:49 PM  
 FILE: pw://tcdot.projectwiseonline.com:16 - CRP/Design Projects/091628071/4 - Design/Plan Set/13\_Standards/BC(4)-21.dgn

**TYPICAL MINIMUM CLEARANCES FOR LONG TERM AND INTERMEDIATE TERM SIGNS**

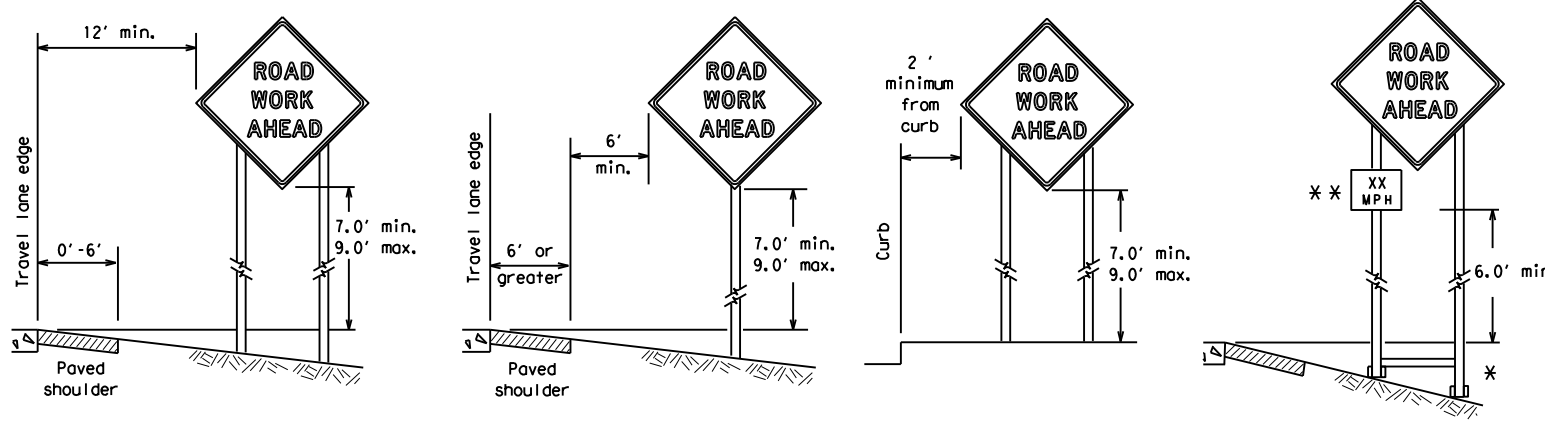

\* When placing skid supports on unlevel ground, the leg post lengths must be adjusted so the sign appears straight and plumb. Objects shall NOT be placed under skids as a means of leveling.

\*\* When plaques are placed on dual-leg supports, they should be attached to the upright nearest the travel lane. Supplemental plaques (advisory or distance) should not cover the surface of the parent sign.

**ATTACHMENT FOR SIGN SUPPORTS**

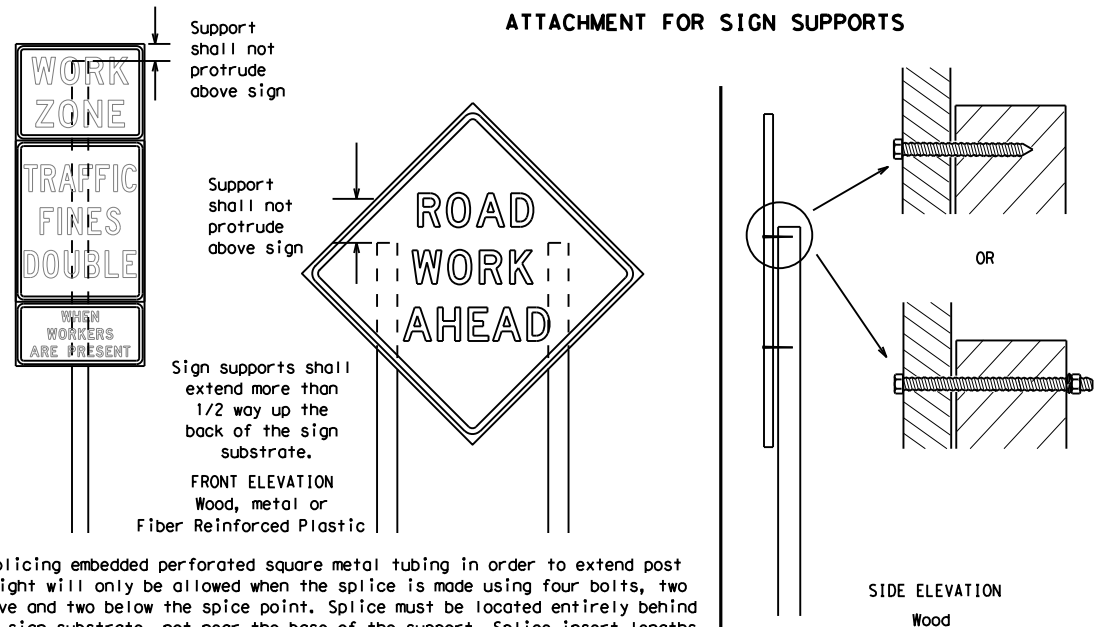

Splicing embedded perforated square metal tubing in order to extend post height will only be allowed when the splice is made using four bolts, two above and two below the splice point. Splice must be located entirely behind the sign substrate, not near the base of the support. Splice insert lengths should be at least 5 times nominal post size, centered on the splice and of at least the same gauge material.

**GENERAL NOTES FOR WORK ZONE SIGNS**

- Contractor shall install and maintain signs in a straight and plumb condition and/or as directed by the Engineer.
- Wooden sign posts shall be painted white.
- Barricades shall NOT be used as sign supports.
- All signs shall be installed in accordance with the plans or as directed by the Engineer. Signs shall be used to regulate, warn, and guide the traveling public safely through the work zone.
- The Contractor may furnish either the sign design shown in the plans or in the "Standard Highway Sign Designs for Texas" (SHSD). The Engineer/Inspector may require the Contractor to furnish other work zone signs that are shown in the TMUTCD but may have been omitted from the plans. Any variation in the plans shall be documented by written agreement between the Engineer and the Contractor's Responsible Person. All changes must be documented in writing before being implemented. This can include documenting the changes in the Inspector's TxDOT diary and having both the Inspector and Contractor initial and date the agreed upon changes.
- The Contractor shall furnish sign supports listed in the "Compliant Work Zone Traffic Control Device List" (CWZTCD) for small roadside signs. Supports for temporary large roadside signs shall meet the requirements detailed on the Temporary Large Roadside Signs (TLRS) standard sheets. The Contractor shall install the sign support in accordance with the manufacturer's recommendations. If there is a question regarding installation procedures, the Contractor shall furnish the Engineer a copy of the manufacturer's installation recommendations so the Engineer can verify the correct procedures are being followed.
- The Contractor is responsible for installing signs on approved supports and replacing signs with damaged or cracked substrates and/or damaged or marred reflective sheeting as directed by the Engineer/Inspector.
- Identification markings may be shown only on the back of the sign substrate. The maximum height of letters and/or company logos used for identification shall be 1 inch.
- The Contractor shall replace damaged wood posts. New or damaged wood sign posts shall not be spliced.

**DURATION OF WORK (as defined by the "Texas Manual on Uniform Traffic Control Devices" Part 6)**

- The types of sign supports, sign mounting height, the size of signs, and the type of sign substrates can vary based on the type of work being performed. The Engineer is responsible for selecting the appropriate size sign for the type of work being performed. The Contractor is responsible for ensuring the sign support, sign mounting height and substrate meets manufacturer's recommendations in regard to crashworthiness and duration of work requirements.
  - Long-term stationary - work that occupies a location more than 3 days.
  - Intermediate-term stationary - work that occupies a location more than one daylight period up to 3 days, or nighttime work lasting more than one hour.
  - Short-term stationary - daytime work that occupies a location for more than 1 hour in a single daylight period.
  - Short, duration - work that occupies a location up to 1 hour.
  - Mobile - work that moves continuously or intermittently (stopping for up to approximately 15 minutes.)

**SIGN MOUNTING HEIGHT**

- The bottom of Long-term/Intermediate-term signs shall be at least 7 feet, but not more than 9 feet, above the paved surface, except as shown for supplemental plaques mounted below other signs.
- The bottom of Short-term/Short Duration signs shall be a minimum of 1 foot above the pavement surface but no more than 2 feet above the ground.
- Long-term/Intermediate-term Signs may be used in lieu of Short-term/Short Duration signing.
- Short-term/Short Duration signs shall be used only during daylight and shall be removed at the end of the workday or raised to appropriate Long-term/Intermediate sign height.
- Regulatory signs shall be mounted at least 7 feet, but not more than 9 feet, above the paved surface regardless of work duration.

**SIZE OF SIGNS**

- The Contractor shall furnish the sign sizes shown on BC (2) unless otherwise shown in the plans or as directed by the Engineer.

**SIGN SUBSTRATES**

- The Contractor shall ensure the sign substrate is installed in accordance with the manufacturer's recommendations for the type of sign support that is being used. The CWZTCD lists each substrate that can be used on the different types and models of sign supports.
- "Mesh" type materials are NOT an approved sign substrate, regardless of the tightness of the weave.
- All wooden individual sign panels fabricated from 2 or more pieces shall have one or more plywood cleat, 1/2" thick by 6" wide, fastened to the back of the sign and extending fully across the sign. The cleat shall be attached to the back of the sign using wood screws that do not penetrate the face of the sign panel. The screws shall be placed on both sides of the splice and spaced at 6" centers. The Engineer may approve other methods of splicing the sign face.

**REFLECTIVE SHEETING**

- All signs shall be retroreflective and constructed of sheeting meeting the color and retro-reflectivity requirements of DMS-8300 for rigid signs or DMS-8310 for roll-up signs. The web address for DMS specifications is shown on BC(1).
- White sheeting, meeting the requirements of DMS-8300 Type A, shall be used for signs with a white background.
- Orange sheeting, meeting the requirements of DMS-8300 Type B<sub>FL</sub> or Type C<sub>FL</sub>, shall be used for rigid signs with orange backgrounds.

**SIGN LETTERS**

- All sign letters and numbers shall be clear, and open rounded type uppercase alphabet letters as approved by the Federal Highway Administration (FHWA) and as published in the "Standard Highway Sign Design for Texas" manual. Signs, letters and numbers shall be of first class workmanship in accordance with Department Standards and Specifications.

**REMOVING OR COVERING**

- When sign messages may be confusing or do not apply, the signs shall be removed or completely covered.
- Long-term stationary or intermediate stationary signs installed on square metal tubing may be turned away from traffic 90 degrees when the sign message is not applicable. This technique may not be used for signs installed in the median of divided highways or near any intersections where the sign may be seen from approaching traffic.
- Signs installed on wooden skids shall not be turned at 90 degree angles to the roadway. These signs should be removed or completely covered when not required.
- When signs are covered, the material used shall be opaque, such as heavy mil black plastic, or other materials which will cover the entire sign face and maintain their opaque properties under automobile headlights at night, without damaging the sign sheeting.
- Burlap shall NOT be used to cover signs.
- Duct tape or other adhesive material shall NOT be affixed to a sign face.
- Signs and anchor stubs shall be removed and holes backfilled upon completion of work.

**SIGN SUPPORT WEIGHTS**

- Where sign supports require the use of weights to keep from turning over, the use of sandbags with dry, cohesionless sand should be used.
- The sandbags will be tied shut to keep the sand from spilling and to maintain a constant weight.
- Rock, concrete, iron, steel or other solid objects shall not be permitted for use as sign support weights.
- Sandbags should weigh a minimum of 35 lbs and a maximum of 50 lbs.
- Sandbags shall be made of a durable material that tears upon vehicular impact. Rubber (such as tire inner tubes) shall NOT be used.
- Rubber ballasts designed for channelizing devices should not be used for ballast on portable sign supports. Sign supports designed and manufactured with rubber bases may be used when shown on the CWZTCD list.
- Sandbags shall only be placed along or laid over the base supports of the traffic control device and shall not be suspended above ground level or hung with rope, wire, chains or other fasteners. Sandbags shall be placed along the length of the skids to weigh down the sign support.
- Sandbags shall NOT be placed under the skid and shall not be used to level sign supports placed on slopes.

**FLAGS ON SIGNS**

- Flags may be used to draw attention to warning signs. When used, the flag shall be 16 inches square or larger and shall be orange or fluorescent red-orange in color. Flags shall not be allowed to cover any portion of the sign face.

**STOP/SLOW PADDLES**

- STOP/SLOW paddles are the primary method to control traffic by flaggers. The STOP/SLOW paddle size should be 24" x 24".
- STOP/SLOW paddles shall be retroreflectORIZED when used at night.
- STOP/SLOW paddles may be attached to a staff with a minimum length of 6' to the bottom of the sign.
- Any lights incorporated into the STOP or SLOW paddle faces shall only be as specifically described in Section 6E.03 Hand Signaling Devices in the TMUTCD.

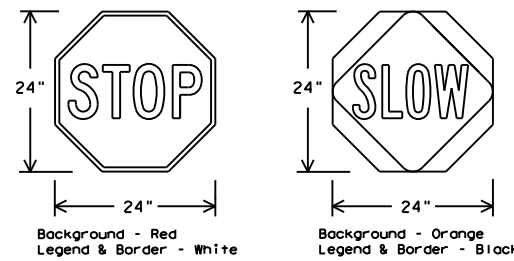

SHEETING REQUIREMENTS (WHEN USED AT NIGHT)		
USAGE	COLOR	SIGN FACE MATERIAL
BACKGROUND	RED	TYPE B OR C SHEETING
BACKGROUND	ORANGE	TYPE B <sub>FL</sub> OR C <sub>FL</sub> SHEETING
LEGEND & BORDER	WHITE	TYPE B OR C SHEETING
LEGEND & BORDER	BLACK	ACRYLIC NON-REFLECTIVE FILM

**CONTRACTOR REQUIREMENTS FOR MAINTAINING PERMANENT SIGNS WITHIN THE PROJECT LIMITS**

- Permanent signs are used to give notice of traffic laws or regulations, call attention to conditions that are potentially hazardous to traffic operations, show route designations, destinations, directions, distances, services, points of interest, and other geographical, recreational, specific service (LOGO), or cultural information. Drivers proceeding through a work zone need the same, if not better route guidance as normally installed on a roadway without construction.
- When permanent regulatory or warning signs conflict with work zone conditions, remove or cover the permanent signs until the permanent sign message matches the roadway condition. For details for covering large guide signs see the TS-CD standard.
- When existing permanent signs are moved and relocated due to construction purposes, they shall be visible to motorists at all times.
- If existing signs are to be relocated on their original supports, they shall be installed on crashworthy bases as shown on the SMD Standard sheets. The signs shall meet the required mounting heights shown on the BC Sheets or the SMD Standards. This work should be paid for under the appropriate pay item for relocating existing signs.
- If permanent signs are to be removed and relocated using temporary supports, the Contractor shall use crashworthy supports as shown on the BC standard sheets, TLRS standard sheets or the CWZTCD list. The signs shall meet the required mounting heights shown on the BC, or the SMD standard sheets during construction. This work should be paid for under the appropriate pay item for relocating existing signs.
- Any sign or traffic control device that is struck or damaged by the Contractor or his/her construction equipment shall be replaced as soon as possible by the Contractor to ensure proper guidance for the motorists. This will be subsidiary to Item 502.

SHEET 4 OF 12

Texas Department of Transportation  
 Traffic Safety Division Standard

**BARRICADE AND CONSTRUCTION TEMPORARY SIGN NOTES**

**BC (4) - 21**

FILE: bc-21.dgn	DN: TxDOT	CR: TxDOT	OW: TxDOT	CK: TxDOT
© TxDOT November 2002	CONT	SECT	JOB	HIGHWAY
REVISIONS	091628	071	PR 25A	
9-07 8-14	DIST	COUNTY	SHEET NO.	
7-13 5-21	CRP	SAN PATRICIO	25	

DATE: 1/13/2023 5:16:49 PM  
 FILE: pw://txdot.projectwiseonline.com:txdot4/Documents/16 - CRP/Design Projects/09162801/4 - Design/Plan Set/13 - Standards/BC(5)-21.dgn  
 DISCLAIMER: The use of this standard is governed by the "Texas Engineering Practice Act". No warranty of any kind is made by TxDOT for any purpose whatsoever. TxDOT assumes no responsibility for the conversion of this standard to other formats or for incorrect results resulting from its use.

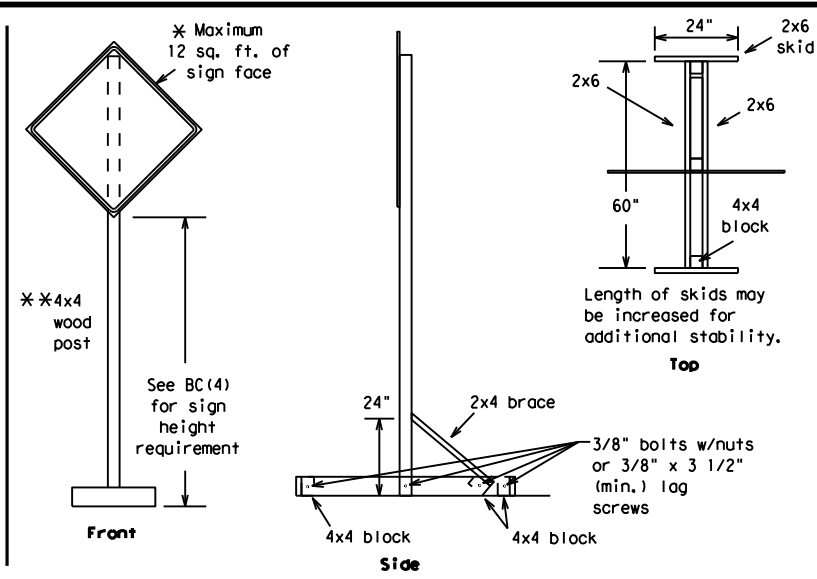
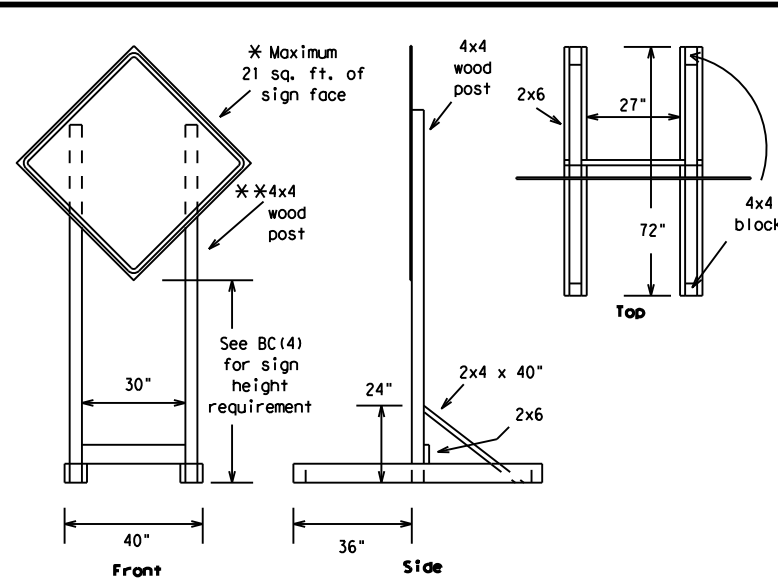

### SKID MOUNTED WOOD SIGN SUPPORTS

\* LONG/INTERMEDIATE TERM STATIONARY - PORTABLE SKID MOUNTED SIGN SUPPORTS

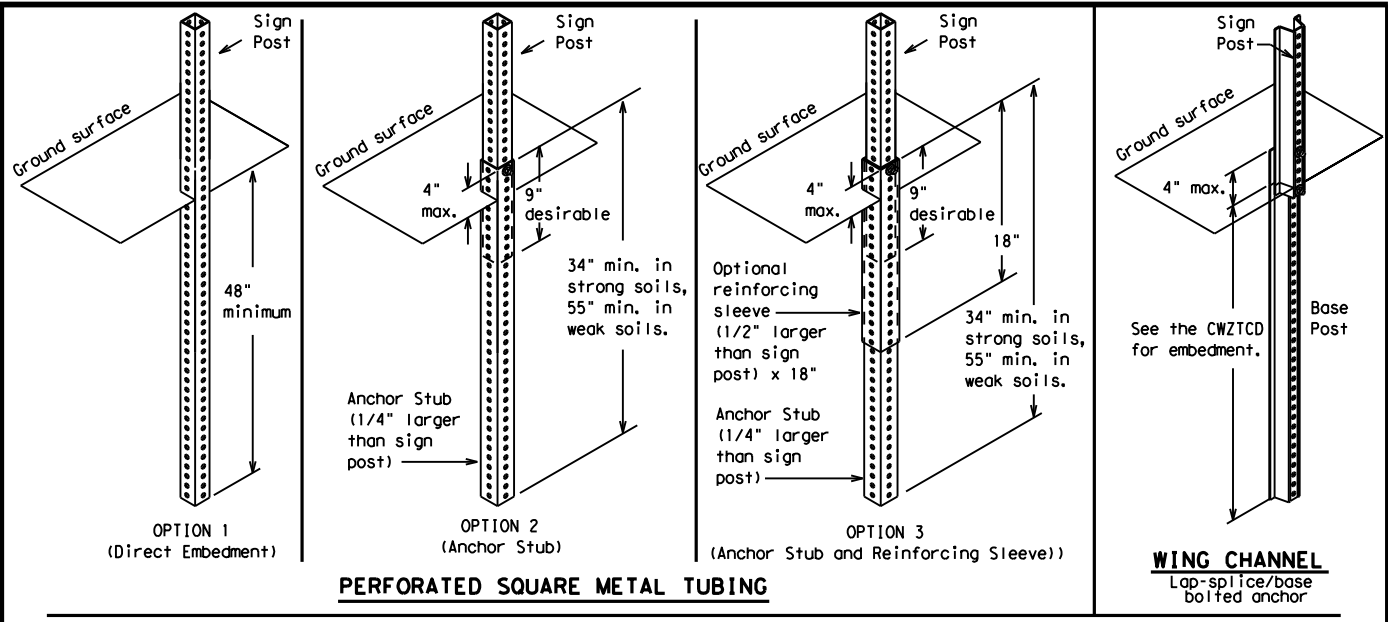

### GROUND MOUNTED SIGN SUPPORTS

Refer to the CWZTCD and the manufacturer's installation procedure for each type sign support. The maximum sign square footage shall adhere to the manufacturer's recommendation. Two post installations can be used for larger signs.

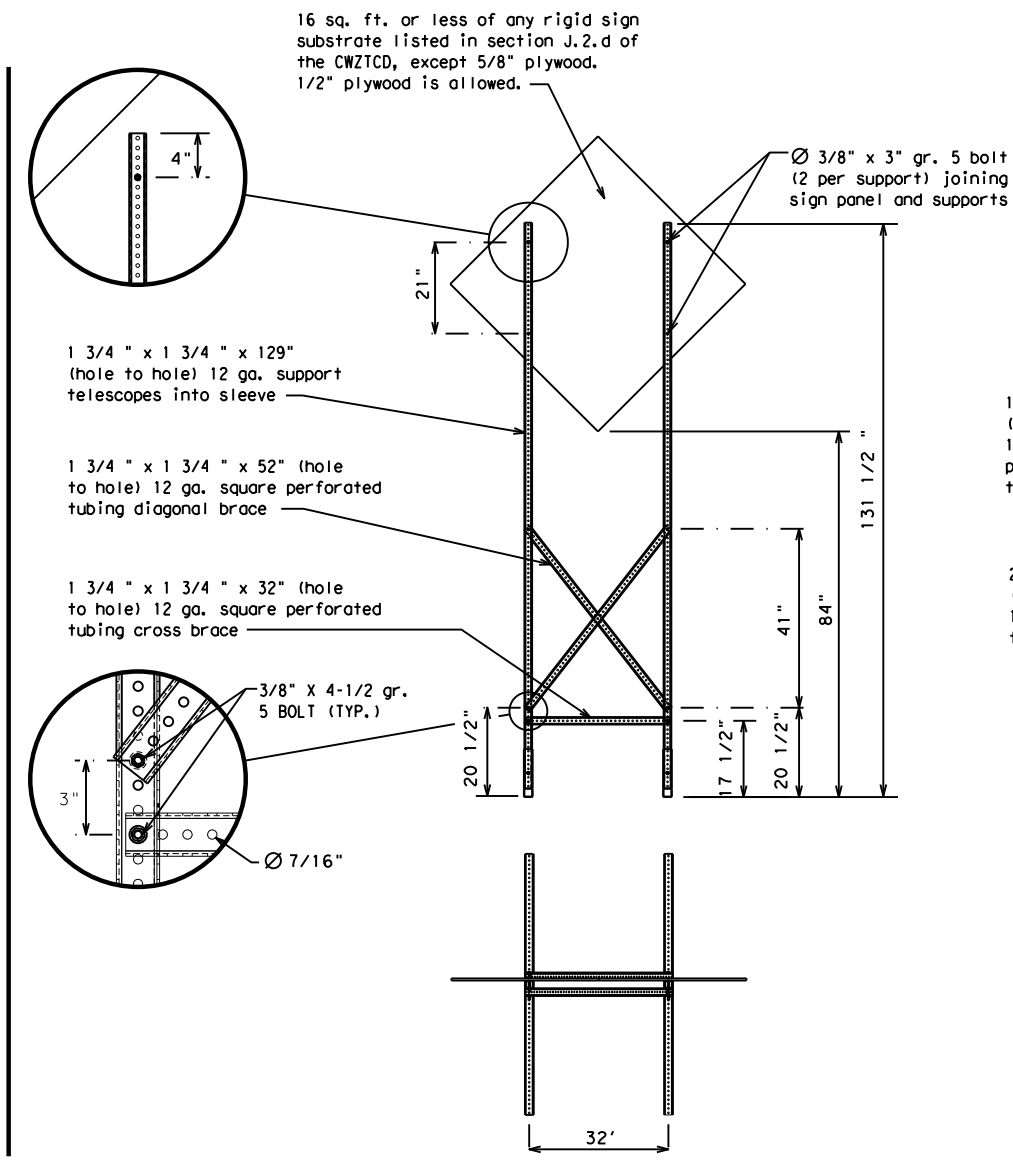
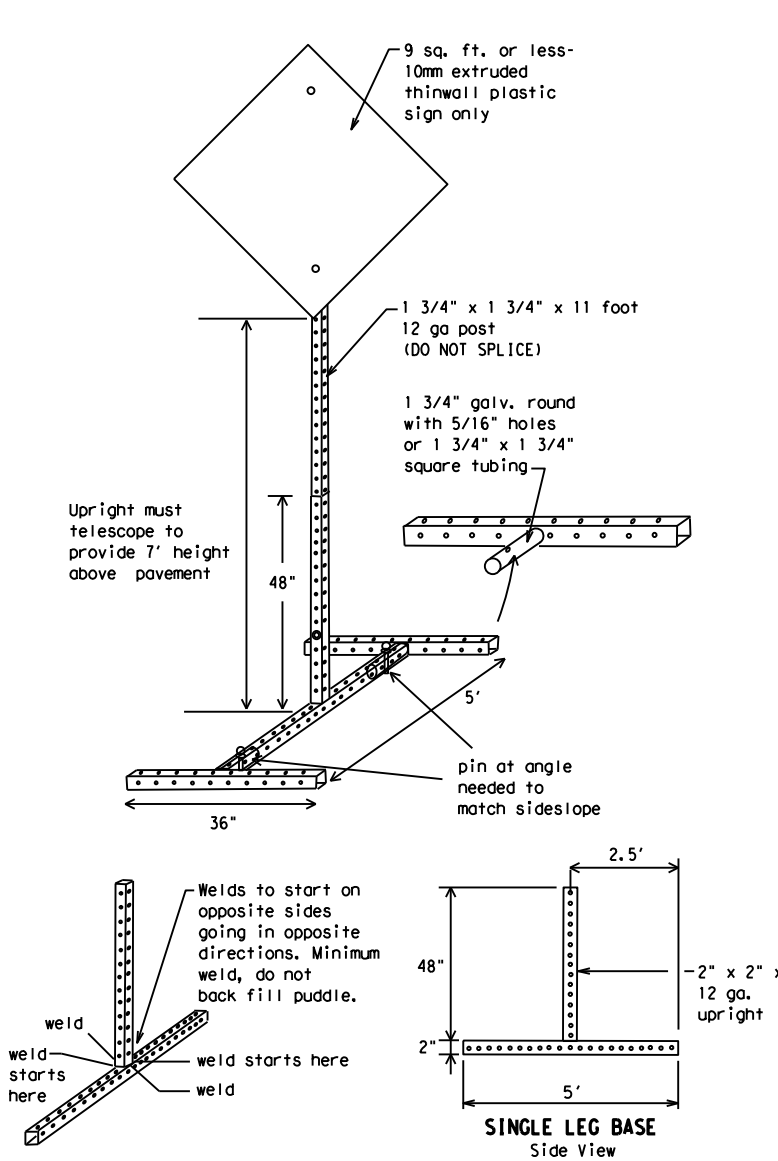

### SKID MOUNTED PERFORATED SQUARE STEEL TUBING SIGN SUPPORTS

\* LONG/INTERMEDIATE TERM STATIONARY - PORTABLE SKID MOUNTED SIGN SUPPORTS

### WEDGE ANCHORS

Both steel and plastic Wedge Anchor Systems as shown on the SMD Standard Sheets may be used as temporary sign supports for signs up to 10 square feet of sign face. They may be set in concrete or in sturdy soils if approved by the Engineer. (See web address for "Traffic Engineering Standard Sheets" on BC(1)).

### OTHER DESIGNS

MORE DETAILS OF APPROVED LONG/INTERMEDIATE AND SHORT TERM SUPPORTS CAN BE FOUND ON THE CWZTCD LIST. SEE BC(1) FOR WEBSITE LOCATION.

- ### GENERAL NOTES
- Nails may be used in the assembly of wooden sign supports, but 3/8" bolts with nuts or 3/8" x 3 1/2" lag screws must be used on every joint for final connection.
  - No more than 2 sign posts shall be placed within a 7 ft. circle, except for specific materials noted on the CWZTCD List.
  - When project is completed, all sign supports and foundations shall be removed from the project site. This will be considered subsidiary to Item 502.
- \* See BC(4) for definition of "Work Duration."  
 \*\* Wood sign posts MUST be one piece. Splicing will NOT be allowed. Posts shall be painted white.  
 See the CWZTCD for the type of sign substrate that can be used for each approved sign support.

## BARRICADE AND CONSTRUCTION TYPICAL SIGN SUPPORT

### BC(5) - 21

FILE:	bc-21.dgn	DN:	TxDOT	CK:	TxDOT	DW:	TxDOT	CR:	TxDOT
©TxDOT	November 2002	CONT	SECT	JOB	HIGHWAY				
REVISIONS		0916	28	071	PR 25A				
9-07	8-14	DIST	COUNTY	SHEET NO.					
7-13	5-21	CRP	SAN PATRICIO	26					

WHEN NOT IN USE, REMOVE THE PCMS FROM THE RIGHT-OF-WAY OR PLACE THE PCMS BEHIND BARRIER OR GUARDRAIL WITH SIGN PANEL TURNED PARALLEL TO TRAFFIC

# RECOMMENDED PHASES AND FORMATS FOR PCMS MESSAGES DURING ROADWORK ACTIVITIES

(The Engineer may approve other messages not specifically covered here.)

## PORTABLE CHANGEABLE MESSAGE SIGNS

- The Engineer/Inspector shall approve all messages used on portable changeable message signs (PCMS).
- Messages on PCMS should contain no more than 8 words (about four to eight characters per word), not including simple words such as "TO," "FOR," "AT," etc.
- Messages should consist of a single phase, or two phases that alternate. Three-phase messages are not allowed. Each phase of the message should convey a single thought, and must be understood by itself.
- Use the word "EXIT" to refer to an exit ramp on a freeway; i.e., "EXIT CLOSED." Do not use the term "RAMP."
- Always use the route or interstate designation (IH, US, SH, FM) along with the number when referring to a roadway.
- When in use, the bottom of a stationary PCMS message panel should be a minimum 7 feet above the roadway, where possible.
- The message term "WEEKEND" should be used only if the work is to start on Saturday morning and end by Sunday evening at midnight. Actual days and hours of work should be displayed on the PCMS if work is to begin on Friday evening and/or continue into Monday morning.
- The Engineer/Inspector may select one of two options which are available for displaying a two-phase message on a PCMS. Each phase may be displayed for either four seconds each or for three seconds each.
- Do not "flash" messages or words included in a message. The message should be steady burn or continuous while displayed.
- Do not present redundant information on a two-phase message; i.e., keeping two lines of the message the same and changing the third line.
- Do not use the word "Danger" in message.
- Do not display the message "LANES SHIFT LEFT" or "LANES SHIFT RIGHT" on a PCMS. Drivers do not understand the message.
- Do not display messages that scroll horizontally or vertically across the face of the sign.
- The following table lists abbreviated words and two-word phrases that are acceptable for use on a PCMS. Both words in a phrase must be displayed together. Words or phrases not on this list should not be abbreviated, unless shown in the TMUTCD.
- PCMS character height should be at least 18 inches for trailer mounted units. They should be visible from at least 1/2 (.5) mile and the text should be legible from at least 600 feet at night and 800 feet in daylight. Truck mounted units must have a character height of 10 inches and must be legible from at least 400 feet.
- Each line of text should be centered on the message board rather than left or right justified.
- If disabled, the PCMS should default to an illegible display that will not alarm motorists and will only be used to alert workers that the PCMS has malfunctioned. A pattern such as a series of horizontal solid bars is appropriate.

## Phase 1: Condition Lists

### Road/Lane/Ramp Closure List

FREEWAY CLOSED X MILE	FRONTAGE ROAD CLOSED
ROAD CLOSED AT SH XXX	SHOULDER CLOSED XXX FT
ROAD CLSD AT FM XXXX	RIGHT LN CLOSED XXX FT
RIGHT X LANES CLOSED	RIGHT X LANES OPEN
CENTER LANE CLOSED	DAYTIME LANE CLOSURES
NIGHT LANE CLOSURES	I-XX SOUTH EXIT CLOSED
VARIOUS LANES CLOSED	EXIT XXX CLOSED X MILE
EXIT CLOSED	RIGHT LN TO BE CLOSED
MALL DRIVEWAY CLOSED	X LANES CLOSED TUE - FRI
XXXXXXXX BLVD CLOSED	

### Other Condition List

ROADWORK XXX FT	ROAD REPAIRS XXXX FT
FLAGGER XXXX FT	LANE NARROWS XXXX FT
RIGHT LN NARROWS XXXX FT	TWO-WAY TRAFFIC XX MILE
MERGING TRAFFIC XXXX FT	CONST TRAFFIC XXX FT
LOOSE GRAVEL XXXX FT	UNEVEN LANES XXXX FT
DETOUR X MILE	ROUGH ROAD XXXX FT
ROADWORK PAST SH XXXX	ROADWORK NEXT FRI-SUN
BUMP XXXX FT	US XXX EXIT X MILES
TRAFFIC SIGNAL XXXX FT	LANES SHIFT *

\* LANES SHIFT in Phase 1 must be used with STAY IN LANE in Phase 2.

## Phase 2: Possible Component Lists

### Action to Take/Effect on Travel List

MERGE RIGHT	FORM X LINES RIGHT
DETOUR NEXT X EXITS	USE XXXXX RD EXIT
USE EXIT XXX	USE EXIT I-XX NORTH
STAY ON US XXX SOUTH	USE I-XX E TO I-XX N
TRUCKS USE US XXX N	WATCH FOR TRUCKS
WATCH FOR TRUCKS	EXPECT DELAYS
EXPECT DELAYS	PREPARE TO STOP
REDUCE SPEED XXX FT	END SHOULDER USE
USE OTHER ROUTES	WATCH FOR WORKERS
STAY IN LANE *	

### Location List

AT FM XXXX
BEFORE RAILROAD CROSSING
NEXT X MILES
PAST US XXX EXIT
XXXXXXXX TO XXXXXX
US XXX TO FM XXXX

### Warning List

SPEED LIMIT XX MPH
MAXIMUM SPEED XX MPH
MINIMUM SPEED XX MPH
ADVISORY SPEED XX MPH
RIGHT LANE EXIT
USE CAUTION
DRIVE SAFELY
DRIVE WITH CARE

### \*\* Advance Notice List

TUE-FRI XX AM-X PM
APR XX-XX X PM-X AM
BEGINS MONDAY
BEGINS MAY XX
MAY X-X XX PM - XX AM
NEXT FRI-SUN
XX AM TO XX PM
NEXT TUE AUG XX
TONIGHT XX PM-XX AM

\*\* See Application Guidelines Note 6.

## APPLICATION GUIDELINES

- Only 1 or 2 phases are to be used on a PCMS.
- The 1st phase (or both) should be selected from the "Road/Lane/Ramp Closure List" and the "Other Condition List".
- A 2nd phase can be selected from the "Action to Take/Effect on Travel, Location, General Warning, or Advance Notice Phase Lists".
- A Location Phase is necessary only if a distance or location is not included in the first phase selected.
- If two PCMS are used in sequence, they must be separated by a minimum of 1000 ft. Each PCMS shall be limited to two phases, and should be understandable by themselves.
- For advance notice, when the current date is within seven days of the actual work date, calendar days should be replaced with days of the week. Advance notification should typically be for no more than one week prior to the work.

## WORDING ALTERNATIVES

- The words RIGHT, LEFT and ALL can be interchanged as appropriate.
- Roadway designations IH, US, SH, FM and LP can be interchanged as appropriate.
- EAST, WEST, NORTH and SOUTH (or abbreviations E, W, N and S) can be interchanged as appropriate.
- Highway names and numbers replaced as appropriate.
- ROAD, HIGHWAY and FREEWAY can be interchanged as needed.
- AHEAD may be used instead of distances if necessary.
- FT and MI, MILE and MILES interchanged as appropriate.
- AT, BEFORE and PAST interchanged as needed.
- Distances or AHEAD can be eliminated from the message if a location phase is used.

PCMS SIGNS WITHIN THE R.O.W. SHALL BE BEHIND GUARDRAIL OR CONCRETE BARRIER OR SHALL HAVE A MINIMUM OF FOUR (4) PLASTIC DRUMS PLACED PERPENDICULAR TO TRAFFIC ON THE UPSTREAM SIDE OF THE PCMS, WHEN EXPOSED TO ONE DIRECTION OF TRAFFIC. WHEN EXPOSED TO TWO WAY TRAFFIC, THE FOUR DRUMS SHOULD BE PLACED WITH ONE DRUM AT EACH OF THE FOUR CORNERS OF THE UNIT.

## FULL MATRIX PCMS SIGNS

- When Full Matrix PCMS signs are used, the character height and legibility/visibility requirements shall be maintained as listed in Note 15 under "PORTABLE CHANGEABLE MESSAGE SIGNS" above.
- When symbol signs, such as the "Flagger Symbol" (CW20-7) are represented graphically on the Full Matrix PCMS sign and, with the approval of the Engineer, it shall maintain the legibility/visibility requirement listed above.
- When symbol signs are represented graphically on the Full Matrix PCMS, they shall only supplement the use of the static sign represented, and shall not substitute for, or replace that sign.
- A full matrix PCMS may be used to simulate a flashing arrow board provided it meets the visibility, flash rate and dimming requirements on BC(7), for the same size arrow.

DISCLAIMER: The use of this standard is governed by the "Texas Engineering Practice Act". No warranty of any kind is made by TxDOT for any purpose whatsoever. TxDOT assumes no responsibility for the conversion of this standard to other formats or for incorrect results resulting from its use.

WORD OR PHRASE	ABBREVIATION	WORD OR PHRASE	ABBREVIATION
Access Road	ACCS RD	Major	MAJ
Alternate	ALT	Miles	MI
Avenue	AVE	Miles Per Hour	MPH
Best Route	BEST RTE	Minor	MNR
Boulevard	BLVD	Monday	MON
Bridge	BRDG	Normal	NORM
Cannot	CANT	North	N
Center	CTR	Northbound	(route) N
Construction Ahead	CONST AHD	Parking	PKING
CROSSING	XING	Road	RD
Detour Route	DETOUR RTE	Right Lane	RT LN
Do Not	DONT	Saturday	SAT
East	E	Service Road	SERV RD
Eastbound	(route) E	Shoulder	SHLDR
Emergency	EMER	Slippery	SLIP
Emergency Vehicle	EMER VEH	South	S
Entrance, Enter	ENT	Southbound	(route) S
Express Lane	EXP LN	Speed	SPD
Expressway	EXPWY	Street	ST
XXXX Feet	XXXX FT	Sunday	SUN
Fog Ahead	FOG AHD	Telephone	PHONE
Freeway	FRWY, FWY	Temporary	TEMP
Freeway Blocked	FWY BLKD	Thursday	THURS
Friday	FRI	To Downtown	TO DWNTN
Hazardous Driving	HAZ DRIVING	Traffic	TRAF
Hazardous Material	HAZMAT	Travelers	TRVLRs
High-Occupancy Vehicle	HOV	Tuesday	TUES
Highway	HWY	Time Minutes	TIME MIN
Hour(s)	HR, HRS	Upper Level	UPR LEVEL
Information	INFO	Vehicles (s)	VEH, VEHS
It Is	ITS	Warning	WARN
Junction	JCT	Wednesday	WED
Left	LFT	Weight Limit	WT LIMIT
Left Lane	LFT LN	West	W
Lane Closed	LN CLOSED	Westbound	(route) W
Lower Level	LWR LEVEL	Wet Pavement	WET PVMT
Maintenance	MAINT	Will Not	WONT

Roadway designation # IH-number, US-number, SH-number, FM-number



## BARRICADE AND CONSTRUCTION PORTABLE CHANGEABLE MESSAGE SIGN (PCMS)

BC (6) - 21

FILE:	bc-21.dgn	DN:	TxDOT	CR:	TxDOT	DW:	TxDOT	CK:	TxDOT
© TxDOT	November 2002	CONT:	SECT:	JOB:	PR	25A			
REVISIONS		0916	28	071	PR 25A				
9-07	8-14	DIST:	COUNTY:	SHEET NO.					
7-13	5-21	CRP:	SAN PATRICIO	27					



DISCLAIMER: The use of this standard is governed by the "Texas Engineering Practice Act". No warranty of any kind is made by TxDOT for any purpose whatsoever. TxDOT assumes no responsibility for the conversion of this standard to other formats or for incorrect results or damages resulting from its use.  
 DATE: 1/13/2023 5:16:50 PM  
 FILE: \\txdot.projectwiseonline.com:CRP/Design Projects/091628071/4 - Design/Plan Set/13\_Standards/TCP/BC(7)-21.dgn

- Barrier Reflectors shall be pre-qualified, and conform to the color and reflectivity requirements of DMS-8600. A list of prequalified Barrier Reflectors can be found at the Material Producer List web address shown on BC(1).
- Color of Barrier Reflectors shall be as specified in the TMUTCD. The cost of the reflectors shall be considered subsidiary to Item 512.

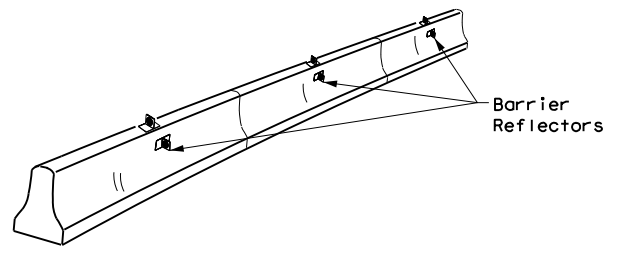

**CONCRETE TRAFFIC BARRIER (CTB)**

- Where traffic is on one side of the CTB, two (2) Barrier Reflectors shall be mounted in approximately the midsection of each section of CTB. An alternate mounting location is uniformly spaced at one end of each CTB. This will allow for attachment of a barrier grapple without damaging the reflector. The Barrier Reflector mounted on the side of the CTB shall be located directly below the reflector mounted on top of the barrier, as shown in the detail above.
- Where CTB separates two-way traffic, three barrier reflectors shall be mounted on each section of CTB. The reflector unit on top shall have two yellow reflective faces (Bi-Directional) while the reflectors on each side of the barrier shall have one yellow reflective face, as shown in the detail above.
- When CTB separates traffic traveling in the same direction, no barrier reflectors will be required on top of the CTB.
- Barrier Reflector units shall be yellow or white in color to match the edgeline being supplemented.
- Maximum spacing of Barrier Reflectors is forty (40) feet.
- Pavement markers or temporary flexible-reflective roadway marker tabs shall NOT be used as CTB delineation.
- Attachment of Barrier Reflectors to CTB shall be per manufacturer's recommendations.
- Missing or damaged Barrier Reflectors shall be replaced as directed by the Engineer.
- Single slope barriers shall be delineated as shown on the above detail.

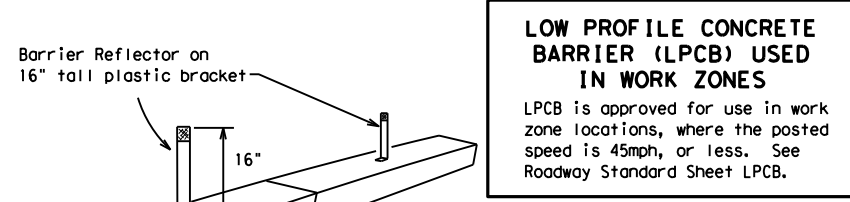

**LOW PROFILE CONCRETE BARRIER (LPCB) USED IN WORK ZONES**  
 LPCB is approved for use in work zone locations, where the posted speed is 45mph, or less. See Roadway Standard Sheet LPCB.

**LOW PROFILE CONCRETE BARRIER (LPCB)**

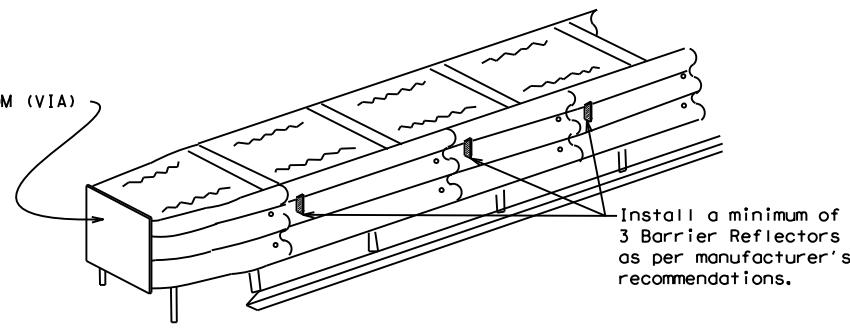

**DELINEATION OF END TREATMENTS**

**END TREATMENTS FOR CTB'S USED IN WORK ZONES**  
 End treatments used on CTB's in work zones shall meet the appropriate crashworthy standards as defined in the Manual for Assessing Safety Hardware (MASH). Refer to the CWZTCD List for approved end treatments and manufacturers.

**BARRIER REFLECTORS FOR CONCRETE TRAFFIC BARRIER AND ATTENUATORS**

**WARNING LIGHTS**

- Warning lights shall meet the requirements of the TMUTCD.
- Warning lights shall NOT be installed on barricades.
- Type A-Low Intensity Flashing Warning Lights are commonly used with drums. They are intended to warn of or mark a potentially hazardous area. Their use shall be as indicated on this sheet and/or other sheets of the plans by the designation "FL". The Type A Warning Lights shall not be used with signs manufactured with Type B<sub>FL</sub> or C<sub>FL</sub> Sheeting meeting the requirements of Departmental Material Specification DMS-8300.
- Type-C and Type D 360 degree Steady Burn Lights are intended to be used in a series for delineation to supplement other traffic control devices. Their use shall be as indicated on this sheet and/or other sheets of the plans by the designation "SB".
- The Engineer/Inspector or the plans shall specify the location and type of warning lights to be installed on the traffic control devices.
- When required by the Engineer, the Contractor shall furnish a copy of the warning lights certification. The warning light manufacturer will certify the warning lights meet the requirements of the latest ITE Purchase Specifications for Flashing and Steady-Burn Warning Lights.
- When used to delineate curves, Type-C and Type D Steady Burn Lights should only be placed on the outside of the curve, not the inside.
- The location of warning lights and warning reflectors on drums shall be as shown elsewhere in the plans.

**WARNING LIGHTS MOUNTED ON PLASTIC DRUMS**

- Type A flashing warning lights are intended to warn drivers that they are approaching or are in a potentially hazardous area.
- Type A random flashing warning lights are not intended for delineation and shall not be used in a series.
- A series of sequential flashing warning lights placed on channelizing devices to form a merging taper may be used for delineation. If used, the successive flashing of the sequential warning lights should occur from the beginning of the taper to the end of the merging taper in order to identify the desired vehicle path. The rate of flashing for each light shall be 65 flashes per minute, plus or minus 10 flashes.
- Type C and D steady-burn warning lights are intended to be used in a series to delineate the edge of the travel lane on detours, on lane changes, on lane closures, and on other similar conditions.
- Type A, Type C and Type D warning lights shall be installed at locations as detailed on other sheets in the plans.
- Warning lights shall not be installed on a drum that has a sign, chevron or vertical panel.
- The maximum spacing for warning lights on drums should be identical to the channelizing device spacing.

**WARNING REFLECTORS MOUNTED ON PLASTIC DRUMS AS A SUBSTITUTE FOR TYPE C (STEADY BURN) WARNING LIGHTS**

- A warning reflector or approved substitute may be mounted on a plastic drum as a substitute for a Type C, steady burn warning light at the discretion of the Contractor unless otherwise noted in the plans.
- The warning reflector shall be yellow in color and shall be manufactured using a sign substrate approved for use with plastic drums listed on the CWZTCD.
- The warning reflector shall have a minimum retroreflective surface area (one-side) of 30 square inches.
- Round reflectors shall be fully reflectorized, including the area where attached to the drum.
- Square substrates must have a minimum of 30 square inches of reflectorized sheeting. They do not have to be reflectorized where it attaches to the drum.
- The side of the warning reflector facing approaching traffic shall have sheeting meeting the color and retroreflectivity requirements for DMS 8300-Type B or Type C.
- When used near two-way traffic, both sides of the warning reflector shall be reflectorized.
- The warning reflector should be mounted on the side of the handle nearest approaching traffic.
- The maximum spacing for warning reflectors should be identical to the channelizing device spacing requirements.

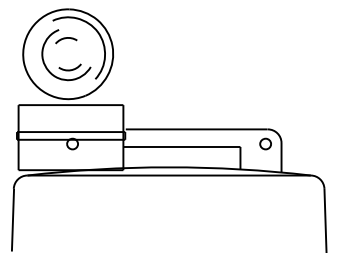

Type C Warning Light or approved substitute mounted on a drum adjacent to the travel way.

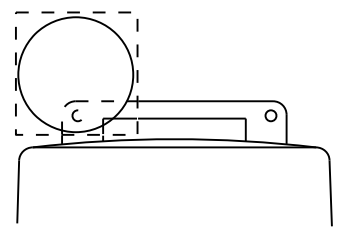

Warning reflector may be round or square. Must have a yellow reflective surface area of at least 30 square inches

Arrow Boards may be located behind channelizing devices in place for a shoulder taper or merging taper, otherwise they shall be delineated with four (4) channelizing devices placed perpendicular to traffic on the upstream side of traffic.

- The Flashing Arrow Board should be used for all lane closures on multi-lane roadways, or slow moving maintenance or construction activities on the travel lanes.
- Flashing Arrow Boards should not be used on two-lane, two-way roadways, detours, diversions or work on shoulders unless the "CAUTION" display (see detail below) is used.
- The Engineer/Inspector shall choose all appropriate signs, barricades and/or other traffic control devices that should be used in conjunction with the Flashing Arrow Board.
- The Flashing Arrow Board should be able to display the following symbols:

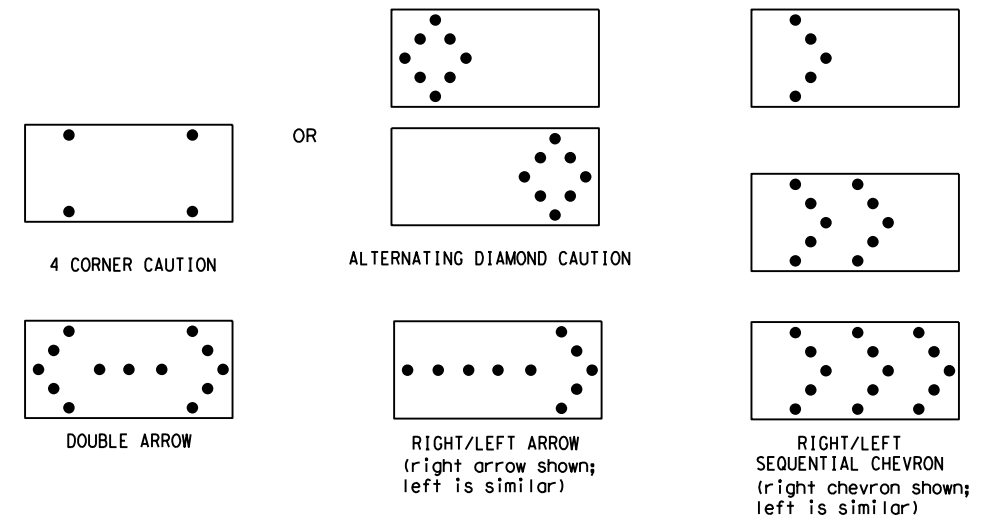

- The "CAUTION" display consists of four corner lamps flashing simultaneously, or the Alternating Diamond Caution mode as shown.
- The straight line caution display is NOT ALLOWED.
- The Flashing Arrow Board shall be capable of minimum 50 percent dimming from rated lamp voltage. The flashing rate of the lamps shall not be less than 25 nor more than 40 flashes per minute.
- Minimum lamp "on time" shall be approximately 50 percent for the flashing arrow and equal intervals of 25 percent for each sequential phase of the flashing chevron.
- The sequential arrow display is NOT ALLOWED.
- The flashing arrow display is the TxDOT standard; however, the sequential chevron display may be used during daylight operations.
- The Flashing Arrow Board shall be mounted on a vehicle, trailer or other suitable support.
- A Flashing Arrow Board SHALL NOT BE USED to laterally shift traffic.
- A full matrix PCMS may be used to simulate a Flashing Arrow Board provided it meets visibility, flash rate and dimming requirements on this sheet for the same size arrow.
- Minimum mounting height of trailer mounted Arrow Boards should be 7 feet from roadway to bottom of panel.

REQUIREMENTS			
TYPE	MINIMUM SIZE	MINIMUM NUMBER OF PANEL LAMPS	MINIMUM VISIBILITY DISTANCE
B	30 x 60	13	3/4 mile
C	48 x 96	15	1 mile

**ATTENTION**  
 Flashing Arrow Boards shall be equipped with automatic dimming devices.

WHEN NOT IN USE, REMOVE THE ARROW BOARD FROM THE RIGHT-OF-WAY OR PLACE THE ARROW BOARD BEHIND CONCRETE TRAFFIC BARRIER OR GUARDRAIL.

**FLASHING ARROW BOARDS**

SHEET 7 OF 12

**TRUCK-MOUNTED ATTENUATORS**

- Truck-mounted attenuators (TMA) used on TxDOT facilities must meet the requirements outlined in the Manual for Assessing Safety Hardware (MASH).
- Refer to the CWZTCD for the requirements of Level 2 or Level 3 TMAs.
- Refer to the CWZTCD for a list of approved TMAs.
- TMAs are required on freeways unless otherwise noted in the plans.
- A TMA should be used anytime that it can be positioned 30 to 100 feet in advance of the area of crew exposure without adversely affecting the work performance.
- The only reason a TMA should not be required is when a work area is spread down the roadway and the work crew is an extended distance from the TMA.

Texas Department of Transportation  
 Traffic Safety Division Standard

**BARRICADE AND CONSTRUCTION ARROW PANEL, REFLECTORS, WARNING LIGHTS & ATTENUATOR**

**BC (7) - 21**

FILE: bc-21.dgn	DN: TxDOT	CR: TxDOT	DW: TxDOT	CK: TxDOT
©TxDOT November 2002	CONT	SECT	JOB	HIGHWAY
REVISIONS	0916	28	071	PR 25A
9-07 8-14	DIST	COUNTY	SHEET NO.	
7-13 5-21	CRP	SAN PATRICIO	28	

DISCLAIMER: The use of this standard is governed by the "Texas Engineering Practice Act". No warranty of any kind is made by TxDOT for any purpose whatsoever. TxDOT assumes no responsibility for the conversion of this standard to other formats or for incorrect results or damages resulting from its use.  
 DATE: 1/13/2023 5:16:50 PM  
 FILE: pw://txdot.projectwiseonline.com:16 - CRP/Design Projects/091628071/4 - Design/Plan Set/13\_Standards/BC(8)-21.dgn

**GENERAL NOTES**

- For long term stationary work zones on freeways, drums shall be used as the primary channelizing device.
- For intermediate term stationary work zones on freeways, drums should be used as the primary channelizing device but may be replaced in tangent sections by vertical panels, or 42" two-piece cones. In tangent sections, one-piece cones may be used with the approval of the Engineer but only if personnel are present on the project at all times to maintain the cones in proper position and location.
- For short term stationary work zones on freeways, drums are the preferred channelizing device but may be replaced in tapers, transitions and tangent sections by vertical panels, two-piece cones or one-piece cones as approved by the Engineer.
- Drums and all related items shall comply with the requirements of the current version of the "Texas Manual on Uniform Traffic Control Devices" (TMUTCD) and the "Compliant Work Zone Traffic Control Devices List" (CWZTCD).
- Drums, bases, and related materials shall exhibit good workmanship and shall be free from objectionable marks or defects that would adversely affect their appearance or serviceability.
- The Contractor shall have a maximum of 24 hours to replace any plastic drums identified for replacement by the Engineer/Inspector. The replacement device must be an approved device.

**GENERAL DESIGN REQUIREMENTS**

- Pre-qualified plastic drums shall meet the following requirements:
- Plastic drums shall be a two-piece design; the "body" of the drum shall be the top portion and the "base" shall be the bottom.
  - The body and base shall lock together in such a manner that the body separates from the base when impacted by a vehicle traveling at a speed of 20 MPH or greater but prevents accidental separation due to normal handling and/or air turbulence created by passing vehicles.
  - Plastic drums shall be constructed of lightweight flexible, and deformable materials. The Contractor shall NOT use metal drums or single piece plastic drums as channelization devices or sign supports.
  - Drums shall present a profile that is a minimum of 18 inches in width at the 36 inch height when viewed from any direction. The height of drum unit (body installed on base) shall be a minimum of 36 inches and a maximum of 42 inches.
  - The top of the drum shall have a built-in handle for easy pickup and shall be designed to drain water and not collect debris. The handle shall have a minimum of two widely spaced 9/16 inch diameter holes to allow attachment of a warning light, warning reflector unit or approved compliant sign.
  - The exterior of the drum body shall have a minimum of four alternating orange and white retroreflective circumferential stripes not less than 4 inches nor greater than 8 inches in width. Any non-reflectorized space between any two adjacent stripes shall not exceed 2 inches in width.
  - Bases shall have a maximum width of 36 inches, a maximum height of 4 inches, and a minimum of two footholds of sufficient size to allow base to be held down while separating the drum body from the base.
  - Plastic drums shall be constructed of ultra-violet stabilized, orange, high-density polyethylene (HDPE) or other approved material.
  - Drum body shall have a maximum unballasted weight of 11 lbs.
  - Drum and base shall be marked with manufacturer's name and model number.

**RETROREFLECTIVE SHEETING**

- The stripes used on drums shall be constructed of sheeting meeting the color and retroreflectivity requirements of Departmental Materials Specification DMS-8300, "Sign Face Materials." Type A or Type B reflective sheeting shall be supplied unless otherwise specified in the plans.
- The sheeting shall be suitable for use on and shall adhere to the drum surface such that, upon vehicular impact, the sheeting shall remain adhered in-place and exhibit no delaminating, cracking, or loss of retroreflectivity other than that loss due to abrasion of the sheeting surface.

**BALLAST**

- Unballasted bases shall be large enough to hold up to 50 lbs. of sand. This base, when filled with the ballast material, should weigh between 35 lbs (minimum) and 50 lbs (maximum). The ballast may be sand in one to three sandbags separate from the base, sand in a sand-filled plastic base, or other ballasting devices as approved by the Engineer. Stacking of sandbags will be allowed, however height of sandbags above pavement surface may not exceed 12 inches.
- Bases with built-in ballast shall weigh between 40 lbs. and 50 lbs. Built-in ballast can be constructed of an integral crumb rubber base or a solid rubber base.
- Recycled truck tire sidewalls may be used for ballast on drums approved for this type of ballast on the CWZTCD list.
- The ballast shall not be heavy objects, water, or any material that would become hazardous to motorists, pedestrians, or workers when the drum is struck by a vehicle.
- When used in regions susceptible to freezing, drums shall have drainage holes in the bottoms so that water will not collect and freeze becoming a hazard when struck by a vehicle.
- Ballast shall not be placed on top of drums.
- Adhesives may be used to secure base of drums to pavement.

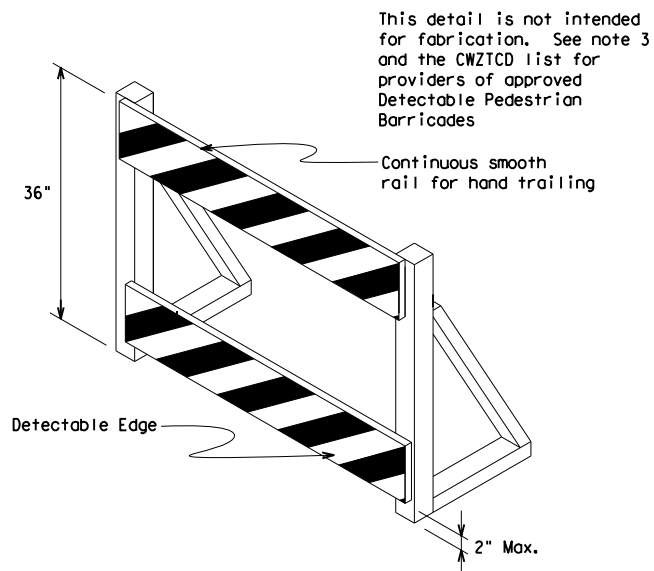
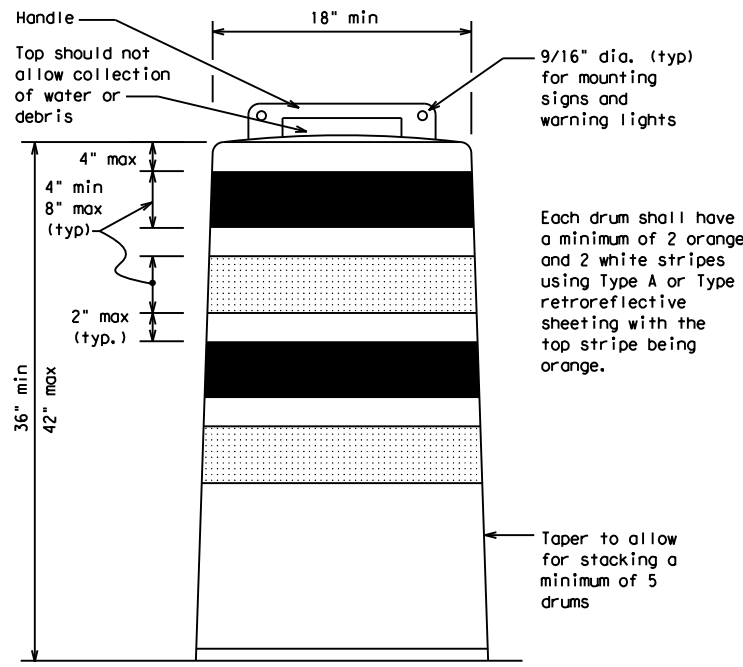

**DETECTABLE PEDESTRIAN BARRICADES**

- When existing pedestrian facilities are disrupted, closed, or relocated in a TTC zone, the temporary facilities shall be detectable and include accessibility features consistent with the features present in the existing pedestrian facility. Refer to WZ(BTS-2) for Pedestrian Control requirements for Sidewalk Diversions, Sidewalk Detours and Crosswalk Closures.
- Where pedestrians with visual disabilities normally use the closed sidewalk, a Detectable Pedestrian Barricade shall be placed across the full width of the closed sidewalk instead of a Type 3 Barricade.
- Detectable pedestrian barricades similar to the one pictured above, longitudinal channelizing devices, some concrete barriers, and wood or chain link fencing with a continuous detectable edging can satisfactorily delineate a pedestrian path.
- Tape, rope, or plastic chain strung between devices are not detectable, do not comply with the design standards in the "Americans with Disabilities Act Accessibility Guidelines (ADAAG)" and should not be used as a control for pedestrian movements.
- Warning lights shall not be attached to detectable pedestrian barricades.
- Detectable pedestrian barricades should use 8" nominal barricade rails as shown on BC(10) provided that the top rail provides a smooth continuous rail suitable for hand trailing with no splinters, burrs, or sharp edges.

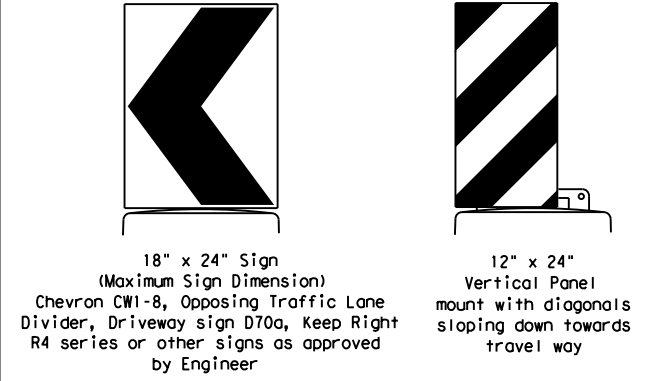

Plywood, Aluminum or Metal sign substrates shall NOT be used on plastic drums

**SIGNS, CHEVRONS, AND VERTICAL PANELS MOUNTED ON PLASTIC DRUMS**

- Signs used on plastic drums shall be manufactured using substrates listed on the CWZTCD.
- Chevrons and other work zone signs with an orange background shall be manufactured with Type B<sub>FL</sub> or Type C<sub>FL</sub> Orange sheeting meeting the color and retroreflectivity requirements of DMS-8300, "Sign Face Material," unless otherwise specified in the plans.
- Vertical Panels shall be manufactured with orange and white sheeting meeting the requirements of DMS-8300 Type A or Type B. Diagonal stripes on Vertical Panels shall slope down toward the intended traveled lane.
- Other sign messages (text or symbolic) may be used as approved by the Engineer. Sign dimensions shall not exceed 18 inches in width or 24 inches in height, except for the R9 series signs discussed in note 8 below.
- Signs shall be installed using a 1/2 inch bolt (nominal) and nut, two washers, and one locking washer for each connection.
- Mounting bolts and nuts shall be fully engaged and adequately torqued. Bolts should not extend more than 1/2 inch beyond nuts.
- Chevrons may be placed on drums on the outside of curves, on merging tapers or on shifting tapers. When used in these locations, they may be placed on every drum or spaced not more than on every third drum. A minimum of three (3) should be used at each location called for in the plans.
- R9-9, R9-10, R9-11 and R9-11a Sidewalk Closed signs which are 24 inches wide may be mounted on plastic drums, with approval of the Engineer.

SHEET 8 OF 12

		Traffic Safety Division Standard	
BARRICADE AND CONSTRUCTION CHANNELIZING DEVICES			
BC (8) - 21			
FILE: bc-21.dgn	DWG: TxDOT	CR: TxDOT	DW: TxDOT
© TxDOT November 2002	CONT	SECT	JOB
REVISIONS	0916	28	071
4-03 8-14			PR 25A
9-07 5-21	DIST	COUNTY	SHEET NO.
7-13	CRP	SAN PATRICIO	29

DISCLAIMER: The use of this standard is governed by the "Texas Engineering Practice Act". No warranty of any kind is made by TxDOT for any purpose whatsoever. TxDOT assumes no responsibility for the conversion of this standard to other formats or for incorrect results or damages resulting from its use.

DATE: 1/13/2023 5:16:50 PM  
 FILE: pw://txdot.projectwiseonline.com:16 - CRP/Design Projects/091628071/4 - Design/Plan Set/13\_Standards/TCP/BC(1)-21.dgn

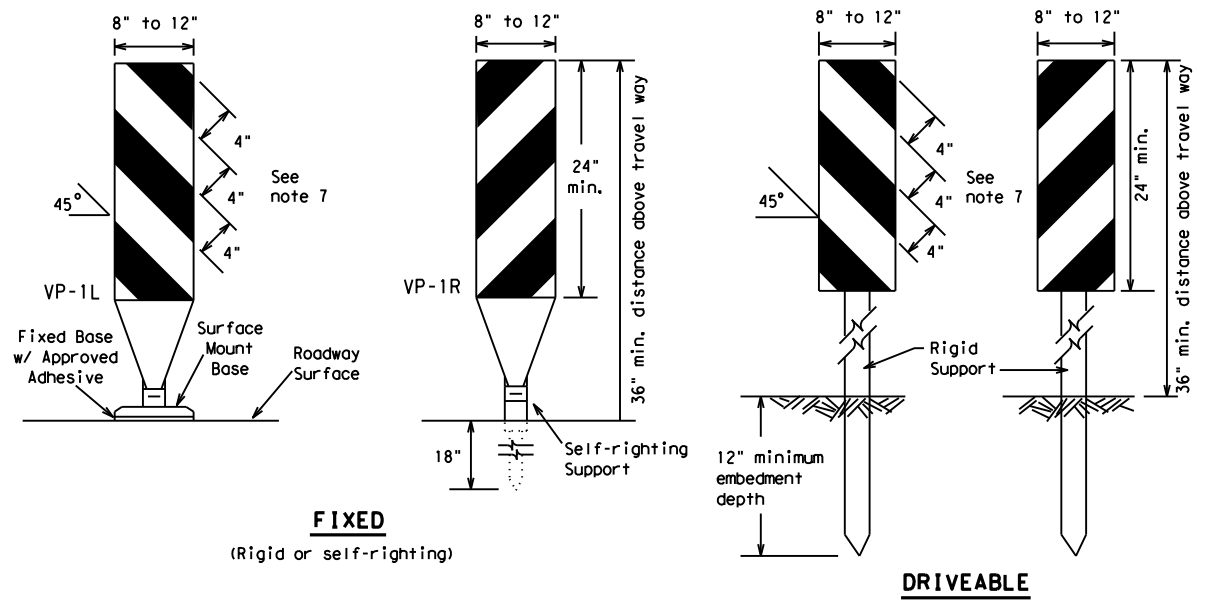

**FIXED**  
(Rigid or self-righting)

**DRIVEABLE**

- Vertical Panels (VP's) are normally used to channelize traffic or divide opposing lanes of traffic.
- VP's may be used in daytime or nighttime situations. They may be used at the edge of shoulder drop-offs and other areas such as lane transitions where positive daytime and nighttime delineation is required. The Engineer/Inspector shall refer to the Roadway Design Manual for additional requirements on the use VP's for drop-offs.
- VP's should be mounted back to back if used at the edge of cuts adjacent to two-way two lane roadways. Stripes are to be reflective orange and reflective white and should always slope downward toward the travel lane.
- VP's used on expressways and freeways or other high speed roadways, may have more than 270 square inches of retroreflective area facing traffic.
- Self-righting supports are available with portable base. See "Compliant Work Zone Traffic Control Devices List" (CWZTCD).
- Sheeting for the VP's shall be retroreflective Type A or Type B conforming to Departmental Material Specification DMS-8300, unless noted otherwise.
- Where the height of reflective material on the vertical panel is 36 inches or greater, a panel stripe of 6 inches shall be used.

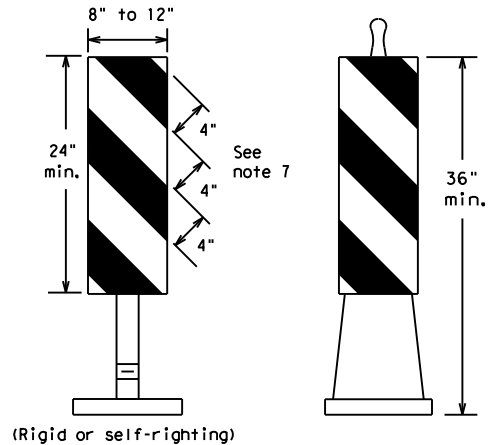

**PORTABLE**

**VERTICAL PANELS (VPs)**

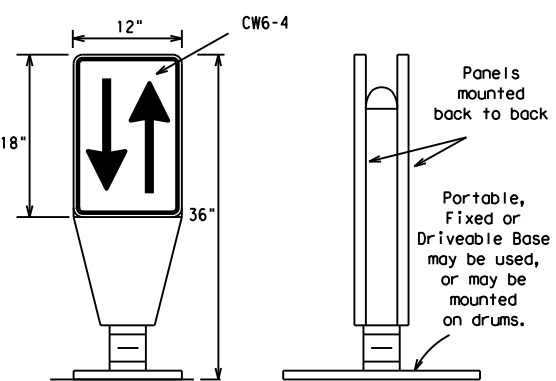

**OPPOSING TRAFFIC LANE DIVIDERS (OTLD)**

- Opposing Traffic Lane Dividers (OTLD) are delineation devices designed to convert a normal one-way roadway section to two-way operation. OTLD's are used on temporary centerlines. The upward and downward arrows on the sign's face indicate the direction of traffic on either side of the divider. The base is secured to the pavement with an adhesive or rubber weight to minimize movement caused by a vehicle impact or wind gust.
- The OTLD may be used in combination with 42" cones or VPs.
- Spacing between the OTLD shall not exceed 500 feet. 42" cones or VPs placed between the OTLD's should not exceed 100 foot spacing.
- The OTLD shall be orange with a black non-reflective legend. Sheeting for the OTLD shall be retroreflective Type B<sub>FL</sub> or Type C<sub>FL</sub> conforming to Departmental Material Specification DMS-8300, unless noted otherwise. The legend shall meet the requirements of DMS-8300.

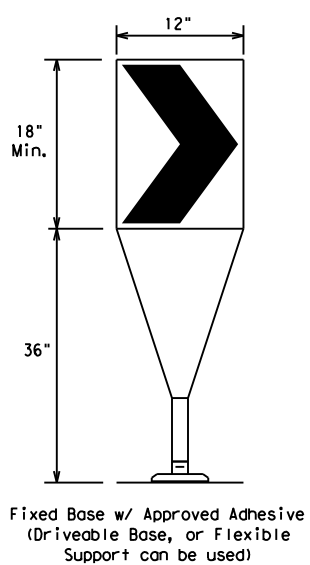

Fixed Base w/ Approved Adhesive (Driveable Base, or Flexible Support can be used)

- The chevron shall be a vertical rectangle with a minimum size of 12 by 18 inches.
- Chevrons are intended to give notice of a sharp change of alignment with the direction of travel and provide additional emphasis and guidance for vehicle operators with regard to changes in horizontal alignment of the roadway.
- Chevrons, when used, shall be erected on the outside of a sharp curve or turn, or on the far side of an intersection. They shall be in line with and at right angles to approaching traffic. Spacing should be such that the motorist always has three in view, until the change in alignment eliminates its need.
- To be effective, the chevron should be visible for at least 500 feet.
- Chevrons shall be orange with a black nonreflective legend. Sheeting for the chevron shall be retroreflective Type B<sub>FL</sub> or Type C<sub>FL</sub> conforming to Departmental Material Specification DMS-8300, unless noted otherwise. The legend shall meet the requirements of DMS-8300.
- For Long Term Stationary use on tapers or transitions on freeways and divided highways, self-righting chevrons may be used to supplement plastic drums but not to replace plastic drums.

**CHEVRONS**

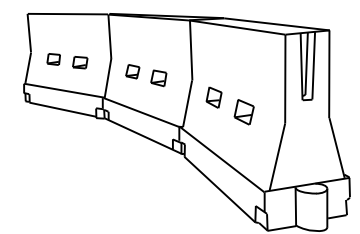

**LONGITUDINAL CHANNELIZING DEVICES (LCD)**

- LCDs are crashworthy, lightweight, deformable devices that are highly visible, have good target value and can be connected together. They are not designed to contain or redirect a vehicle on impact.
- LCDs may be used instead of a line of cones or drums.
- LCDs shall be placed in accordance to application and installation requirements specific to the device, and used only when shown on the CWZTCD list.
- LCDs should not be used to provide positive protection for obstacles, pedestrians or workers.
- LCDs shall be supplemented with retroreflective delineation as required for temporary barriers on BC(7) when placed roughly parallel to the travel lanes.
- LCDs used as barricades placed perpendicular to traffic should have at least one row of reflective sheeting meeting the requirements for barricade rails as shown on BC(10). Place reflective sheeting near the top of the LCD along the full length of the device.

**WATER BALLASTED SYSTEMS USED AS BARRIERS**

- Water ballasted systems used as barriers shall not be used solely to channelize road users, but also to protect the work space per the appropriate Manual for Assessing Safety Hardware (MASH) crashworthiness requirements based on roadway speed and barrier application.
- Water ballasted systems used to channelize vehicular traffic shall be supplemented with retroreflective delineation or channelizing devices to improve daytime/nighttime visibility. They may also be supplemented with pavement markings.
- Water ballasted systems used as barriers shall be placed in accordance to application and installation requirements specific to the device, and used only when shown on the CWZTCD list.
- Water ballasted systems used as barriers should not be used for a merging taper except in low speed (less than 45 MPH) urban areas. When used on a taper in a low speed urban area, the taper shall be delineated and the taper length should be designed to optimize road user operations considering the available geometric conditions.
- When water ballasted systems used as barriers have blunt ends exposed to traffic, they should be attenuated as per manufacturer recommendations or flared to a point outside the clear zone.

If used to channelize pedestrians, longitudinal channelizing devices or water ballasted systems must have a continuous detectable bottom for users of long canes and the top of the unit shall not be less than 32 inches in height.

**HOLLOW OR WATER BALLASTED SYSTEMS USED AS LONGITUDINAL CHANNELIZING DEVICES OR BARRIERS**

**GENERAL NOTES**

- Work Zone channelizing devices illustrated on this sheet may be installed in close proximity to traffic and are suitable for use on high or low speed roadways. The Engineer/Inspector shall ensure that spacing and placement is uniform and in accordance with the "Texas Manual on Uniform Traffic Control Devices" (TMUTCD).
- Channelizing devices shown on this sheet may have a driveable, fixed or portable base. The requirement for self-righting channelizing devices must be specified in the General Notes or other plan sheets.
- Channelizing devices on self-righting supports should be used in work zone areas where channelizing devices are frequently impacted by errant vehicles or vehicle related wind gusts making alignment of the channelizing devices difficult to maintain. Locations of these devices shall be detailed elsewhere in the plans. These devices shall conform to the TMUTCD and the "Compliant Work Zone Traffic Control Devices List" (CWZTCD).
- The Contractor shall maintain devices in a clean condition and replace damaged, nonreflective, faded, or broken devices and bases as required by the Engineer/Inspector. The Contractor shall be required to maintain proper device spacing and alignment.
- Portable bases shall be fabricated from virgin and/or recycled rubber. The portable bases shall weigh a minimum of 30 lbs.
- Pavement surfaces shall be prepared in a manner that ensures proper bonding between the adhesives, the fixed mount bases and the pavement surface. Adhesives shall be prepared and applied according to the manufacturer's recommendations.
- The installation and removal of channelizing devices shall not cause detrimental effects to the final pavement surfaces, including pavement surface discoloration or surface integrity. Driveable bases shall not be permitted on final pavement surfaces. The Engineer/Inspector shall approve all application and removal procedures of fixed bases.

Posted Speed	Formula	Minimum Desirable Taper Lengths **			Suggested Maximum Spacing of Channelizing Devices	
		10' Offset	11' Offset	12' Offset	On a Taper	On a Tangent
30	L = WS <sup>2</sup> / 60	150'	165'	180'	30'	60'
35		205'	225'	245'	35'	70'
40		265'	295'	320'	40'	80'
45	L = WS	450'	495'	540'	45'	90'
50		500'	550'	600'	50'	100'
55		550'	605'	660'	55'	110'
60		600'	660'	720'	60'	120'
65		650'	715'	780'	65'	130'
70		700'	770'	840'	70'	140'
75		750'	825'	900'	75'	150'
80		800'	880'	960'	80'	160'

\*\*Taper lengths have been rounded off.  
 L=Length of Taper (FT.) W=Width of Offset (FT.)  
 S=Posted Speed (MPH)

**SUGGESTED MAXIMUM SPACING OF CHANNELIZING DEVICES AND MINIMUM DESIRABLE TAPER LENGTHS**

SHEET 9 OF 12



**BARRICADE AND CONSTRUCTION CHANNELIZING DEVICES**

**BC (9) - 21**

FILE: bc-21.dgn	DN: TxDOT	CK: TxDOT	DW: TxDOT	CR: TxDOT
© TxDOT November 2002	CONT	SECT	JOB	HIGHWAY
REVISIONS	0916	28	071	PR 25A
9-07 8-14	DIST	COUNTY	SHEET NO.	
7-13 5-21	CRP	SAN PATRICIO	30	

DATE: 1/13/2023 5:16:51 PM  
 FILE: \\txdot.projectwiseonline.com:txdot4\Documents\16 - CRP\Design Projects\091628071\4 - Design\Plan Set\13 - Standards\TCP\BC(10)-21.dgn  
 The use of this standard is governed by the "Texas Engineering Practice Act". No warranty of any kind is made by TxDOT for any purpose whatsoever. TxDOT assumes no responsibility for the conversion of this standard to other formats or for incorrect results or damages resulting from its use.

**TYPE 3 BARRICADES**

1. Refer to the Compliant Work Zone Traffic Control Devices List (CWZTCD) for details of the Type 3 Barricades and a list of all materials used in the construction of Type 3 Barricades.
2. Type 3 Barricades shall be used at each end of construction projects closed to all traffic.
3. Barricades extending across a roadway should have stripes that slope downward in the direction toward which traffic must turn in detouring. When both right and left turns are provided, the chevron striping may slope downward in both directions from the center of the barricade. Where no turns are provided at a closed road, striping should slope downward in both directions toward the center of roadway.
4. Striping of rails, for the right side of the roadway, should slope downward to the left. For the left side of the roadway, striping should slope downward to the right.
5. Identification markings may be shown only on the back of the barricade rails. The maximum height of letters and/or company logos used for identification shall be 1".
6. Barricades shall not be placed parallel to traffic unless an adequate clear zone is provided.
7. Warning lights shall NOT be installed on barricades.
8. Where barricades require the use of weights to keep from turning over, the use of sandbags with dry, cohesionless sand is recommended. The sandbags will be tied shut to keep the sand from spilling and to maintain a constant weight. Sand bags shall not be stacked in a manner that covers any portion of a barricade rails reflective sheeting. Rock, concrete, iron, steel or other solid objects will NOT be permitted. Sandbags should weigh a minimum of 35 lbs and a maximum of 50 lbs. Sandbags shall be made of a durable material that tears upon vehicular impact. Rubber (such as tire inner tubes) shall not be used for sandbags. Sandbags shall only be placed along or upon the base supports of the device and shall not be suspended above ground level or hung with rope, wire, chains or other fasteners.
9. Sheeting for barricades shall be retroreflective Type A or Type B conforming to Departmental Material Specification DMS-8300 unless otherwise noted.

Barricades shall NOT be used as a sign support.



**TYPICAL STRIPING DETAIL FOR BARRICADE RAIL**



Stiffener may be inside or outside of support, but no more than 2 stiffeners shall be allowed on one barricade.

**TYPICAL PANEL DETAIL FOR SKID OR POST TYPE BARRICADES**

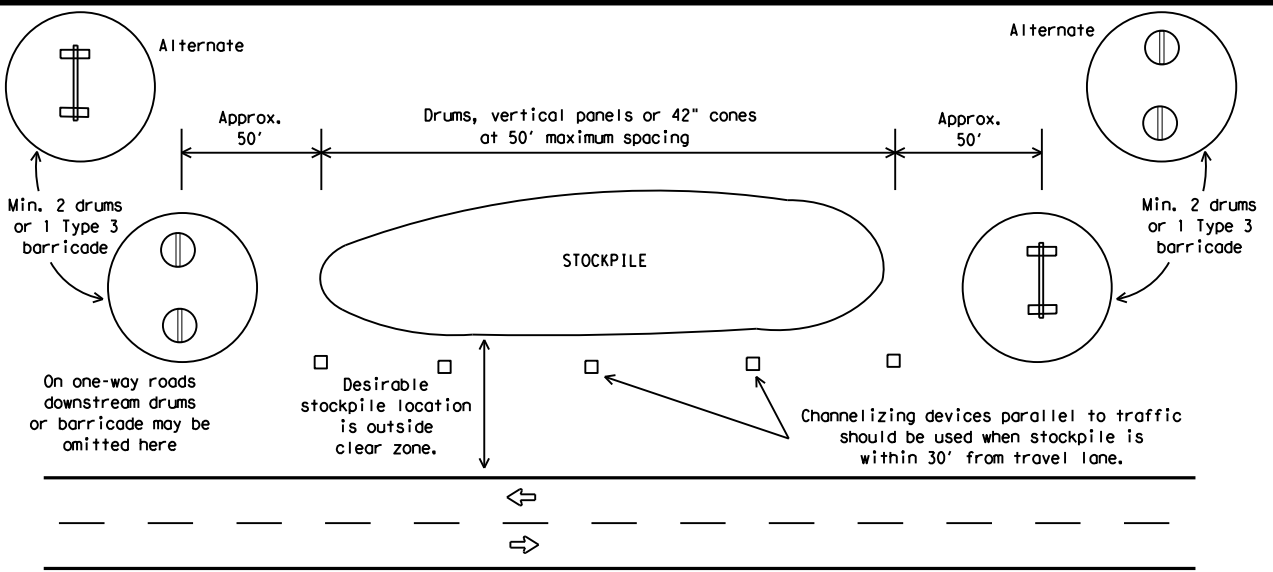

**TRAFFIC CONTROL FOR MATERIAL STOCKPILES**

Each roadway of a divided highway shall be barricaded in the same manner.

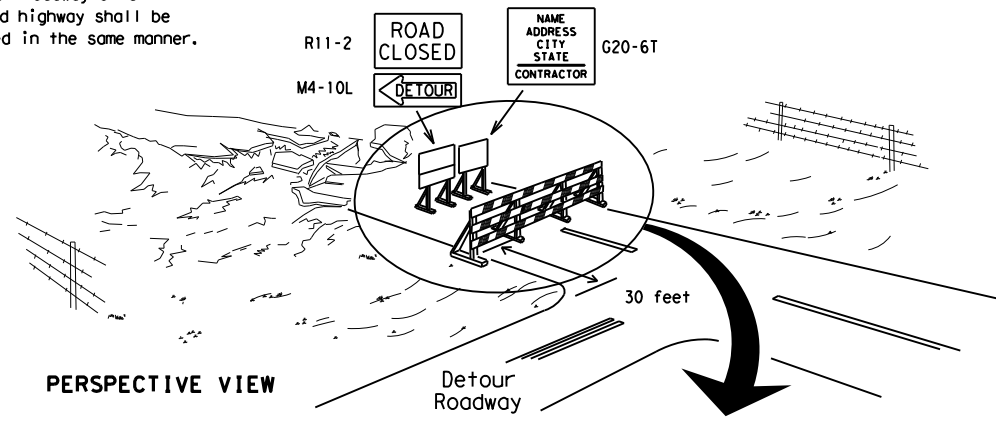

PERSPECTIVE VIEW

The three rails on Type 3 barricades shall be reflectorized orange and reflective white stripes on one side facing one-way traffic and both sides for two-way traffic. Barricade striping should slant downward in the direction of detour.

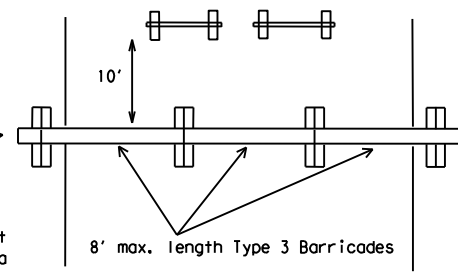

PLAN VIEW

1. Signs should be mounted on independent supports at a 7 foot mounting height in center of roadway. The signs should be a minimum of 10 feet behind Type 3 Barricades.
2. Advance signing shall be as specified elsewhere in the plans.

**TYPE 3 BARRICADE (POST AND SKID) TYPICAL APPLICATION**

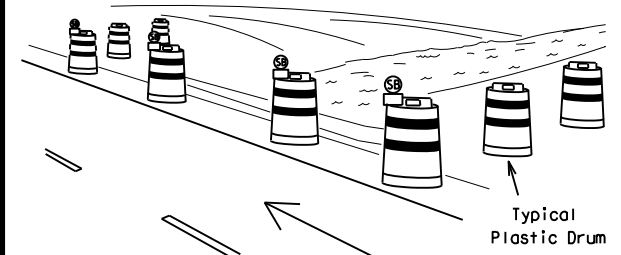

PERSPECTIVE VIEW

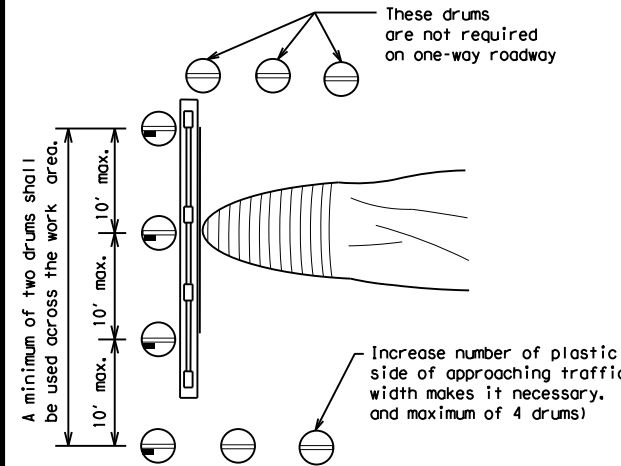

PLAN VIEW

**CULVERT WIDENING OR OTHER ISOLATED WORK WITHIN THE PROJECT LIMITS**

1. Where positive redirection capability is provided, drums may be omitted.
2. Plastic construction fencing may be used with drums for safety as required in the plans.
3. Vertical Panels on flexible support may be substituted for drums when the shoulder width is less than 4 feet.
4. When the shoulder width is greater than 12 feet, steady-burn lights may be omitted if drums are used.
5. Drums must extend the length of the culvert widening.

LEGEND	
	Plastic drum
	Plastic drum with steady burn light or yellow warning reflector
	Steady burn warning light or yellow warning reflector

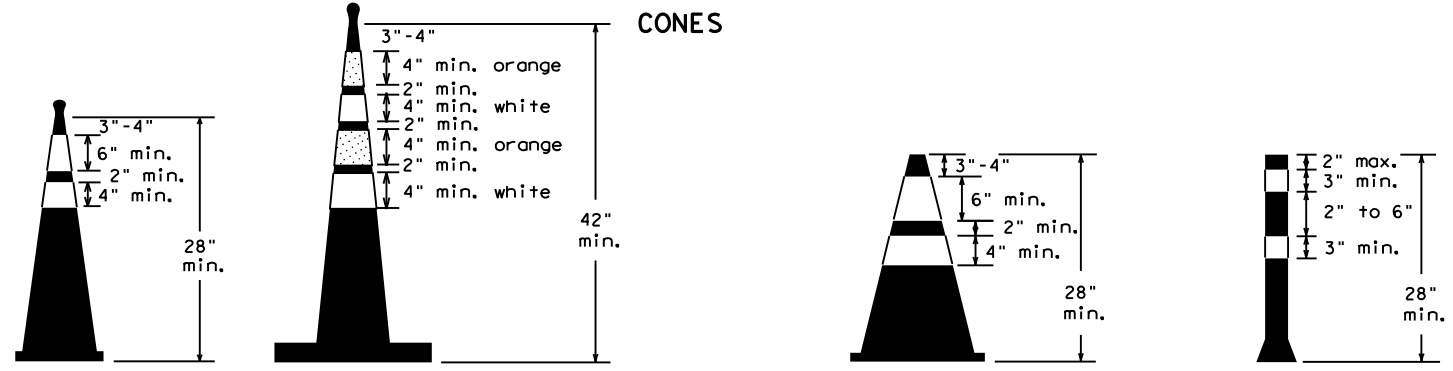

Two-Piece cones

One-Piece cones

Tubular Marker

28" Cones shall have a minimum weight of 9 1/2 lbs.  
 42" 2-piece cones shall have a minimum weight of 30 lbs. including base.

1. Traffic cones and tubular markers shall be predominantly orange, and meet the height and weight requirements shown above.
2. One-piece cones have the body and base of the cone molded in one consolidated unit. Two-piece cones have a cone shaped body and a separate rubber base, or ballast, that is added to keep the device upright and in place.
3. Two-piece cones may have a handle or loop extending up to 8" above the minimum height shown, in order to aid in retrieving the device.
4. Cones or tubular markers shall have white or white and orange reflective bands as shown above. The reflective bands shall have a smooth, sealed outer surface and meet the requirements of Departmental Material Specification DMS-8300 Type A or Type B.
5. 28" cones and tubular markers are generally suitable for short duration and short-term stationary work as defined on BC(4). These should not be used for intermediate-term or long-term stationary work unless personnel is on-site to maintain them in their proper upright position.
6. 42" two-piece cones, vertical panels or drums are suitable for all work zone durations.
7. Cones or tubular markers used on each project should be of the same size and shape.



**BARRICADE AND CONSTRUCTION CHANNELIZING DEVICES**

**BC(10)-21**

FILE: bc-21.dgn	DN: TxDOT	CK: TxDOT	DW: TxDOT	CR: TxDOT
© TxDOT November 2002	CONT	SECT	JOB	HIGHWAY
REVISIONS	0916	28	071	PR 25A
9-07 8-14	DIST	COUNTY	SHEET NO.	
7-13 5-21	CRP	SAN PATRICIO	31	

## WORK ZONE PAVEMENT MARKINGS

### GENERAL

- The Contractor shall be responsible for maintaining work zone and existing pavement markings, in accordance with the standard specifications and special provisions, on all roadways open to traffic within the CSJ limits unless otherwise stated in the plans.
- Color, patterns and dimensions shall be in conformance with the "Texas Manual on Uniform Traffic Control Devices" (TMUTCD).
- Additional supplemental pavement marking details may be found in the plans or specifications.
- Pavement markings shall be installed in accordance with the TMUTCD and as shown on the plans.
- When short term markings are required on the plans, short term markings shall conform with the TMUTCD, the plans and details as shown on the Standard Plan Sheet WZ(STPM).
- When standard pavement markings are not in place and the roadway is opened to traffic, DO NOT PASS signs shall be erected to mark the beginning of the sections where passing is prohibited and PASS WITH CARE signs at the beginning of sections where passing is permitted.
- All work zone pavement markings shall be installed in accordance with Item 662, "Work Zone Pavement Markings."

### RAISED PAVEMENT MARKERS

- Raised pavement markers are to be placed according to the patterns on BC(12).
- All raised pavement markers used for work zone markings shall meet the requirements of Item 672, "RAISED PAVEMENT MARKERS" and Departmental Material Specification DMS-4200 or DMS-4300.

### PREFABRICATED PAVEMENT MARKINGS

- Removable prefabricated pavement markings shall meet the requirements of DMS-8241.
- Non-removable prefabricated pavement markings (foil back) shall meet the requirements of DMS-8240.

### MAINTAINING WORK ZONE PAVEMENT MARKINGS

- The Contractor will be responsible for maintaining work zone pavement markings within the work limits.
- Work zone pavement markings shall be inspected in accordance with the frequency and reporting requirements of work zone traffic control device inspections as required by Form 599.
- The markings should provide a visible reference for a minimum distance of 300 feet during normal daylight hours and 160 feet when illuminated by automobile low-beam headlights at night, unless sight distance is restricted by roadway geometrics.
- Markings failing to meet this criteria within the first 30 days after placement shall be replaced at the expense of the Contractor as per Specification Item 662.

### REMOVAL OF PAVEMENT MARKINGS

- Pavement markings that are no longer applicable, could create confusion or direct a motorist toward or into the closed portion of the roadway shall be removed or obliterated before the roadway is opened to traffic.
- The above shall not apply to detours in place for less than three days, where flaggers and/or sufficient channelizing devices are used in lieu of markings to outline the detour route.
- Pavement markings shall be removed to the fullest extent possible, so as not to leave a discernable marking. This shall be by any method approved by TxDOT Specification Item 677 for "Eliminating Existing Pavement Markings and Markers".
- The removal of pavement markings may require resurfacing or seal coating portions of the roadway as described in Item 677.
- Subject to the approval of the Engineer, any method that proves to be successful on a particular type pavement may be used.
- Blast cleaning may be used but will not be required unless specifically shown in the plans.
- Over-painting of the markings SHALL NOT BE permitted.
- Removal of raised pavement markers shall be as directed by the Engineer.
- Removal of existing pavement markings and markers will be paid for directly in accordance with Item 677, "ELIMINATING EXISTING PAVEMENT MARKINGS AND MARKERS," unless otherwise stated in the plans.
- Black-out marking tape may be used to cover conflicting existing markings for periods less than two weeks when approved by the Engineer.

## Temporary Flexible-Reflective Roadway Marker Tabs

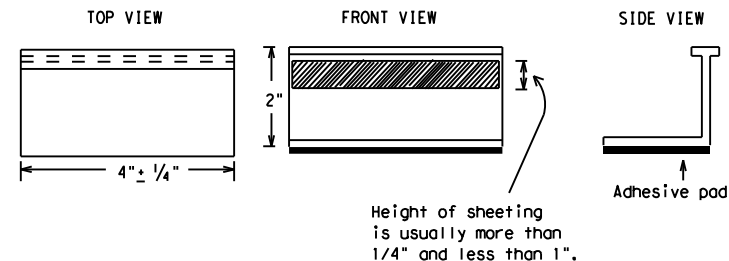

**STAPLES OR NAILS SHALL NOT BE USED TO SECURE  
TEMPORARY FLEXIBLE-REFLECTIVE ROADWAY MARKER  
TABS TO THE PAVEMENT SURFACE**

- Temporary flexible-reflective roadway marker tabs used as guidemarks shall meet the requirements of DMS-8242.
- Tabs detailed on this sheet are to be inspected and accepted by the Engineer or designated representative. Sampling and testing is not normally required, however at the option of the Engineer, either "A" or "B" below may be imposed to assure quality before placement on the roadway.
  - Select five (5) or more tabs at random from each lot or shipment and submit to the Construction Division, Materials and Pavement Section to determine specification compliance.
  - Select five (5) tabs and perform the following test. Affix five (5) tabs at 24 inch intervals on an asphaltic pavement in a straight line. Using a medium size passenger vehicle or pickup, run over the markers with the front and rear tires at a speed of 35 to 40 miles per hour, four (4) times in each direction. No more than one (1) out of the five (5) reflective surfaces shall be lost or displaced as a result of this test.
- Small design variances may be noted between tab manufacturers.
- See Standard Sheet WZ(STPM) for tab placement on new pavements. See Standard Sheet TCP(7-1) for tab placement on seal coat work.

### RAISED PAVEMENT MARKERS USED AS GUIDEMARKS

- Raised pavement markers used as guidemarks shall be from the approved product list, and meet the requirements of DMS-4200.
- All temporary construction raised pavement markers provided on a project shall be of the same manufacturer.
- Adhesive for guidemarks shall be bituminous material hot applied or butyl rubber pad for all surfaces, or thermoplastic for concrete surfaces.

Guidemarks shall be designated as:  
 YELLOW - (two amber reflective surfaces with yellow body).  
 WHITE - (one silver reflective surface with white body).

DEPARTMENTAL MATERIAL SPECIFICATIONS	
PAVEMENT MARKERS (REFLECTORIZED)	DMS-4200
TRAFFIC BUTTONS	DMS-4300
EPOXY AND ADHESIVES	DMS-6100
BITUMINOUS ADHESIVE FOR PAVEMENT MARKERS	DMS-6130
PERMANENT PREFABRICATED PAVEMENT MARKINGS	DMS-8240
TEMPORARY REMOVABLE, PREFABRICATED PAVEMENT MARKINGS	DMS-8241
TEMPORARY FLEXIBLE, REFLECTIVE ROADWAY MARKER TABS	DMS-8242

A list of prequalified reflective raised pavement markers, non-reflective traffic buttons, roadway marker tabs and other pavement markings can be found at the Material Producer List web address shown on BC(1).

SHEET 11 OF 12



## BARRICADE AND CONSTRUCTION PAVEMENT MARKINGS

**BC(11)-21**

FILE: bc-21.dgn	DN: TxDOT	CK: TxDOT	DW: TxDOT	CK: TxDOT
© TxDOT February 1998	CONT	SECT	JOB	HIGHWAY
	0916	28	071	PR 25A
REVISIONS	DIST	COUNTY	SHEET NO.	
2-98 9-07 5-21	CRP	SAN PATRICIO	32	
1-02 7-13				
11-02 8-14				

DISCLAIMER: The use of this standard is governed by the "Texas Engineering Practice Act". No warranty of any kind is made by TxDOT for any purpose whatsoever. TxDOT assumes no responsibility for the conversion of this standard to other formats or for incorrect results or damages resulting from its use.  
 DATE: 1/13/2023 5:16:51 PM  
 FILE: pw://txdot.projectwiseonline.com:txdot4/Documents/16 - CRP/Design Projects/091628071/4 - Design/Plan Set/13 - Standards/TCP/BC(11)-21.dgn

## PAVEMENT MARKING PATTERNS



REFLECTORIZED PAVEMENT MARKINGS - PATTERN A

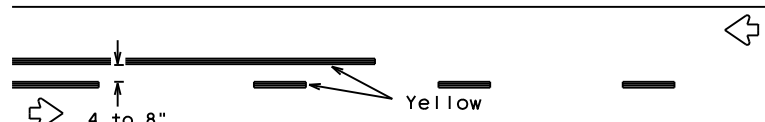

REFLECTORIZED PAVEMENT MARKINGS - PATTERN B

Pattern A is the TXDOT Standard, however Pattern B may be used if approved by the Engineer. Prefabricated markings may be substituted for reflectORIZED pavement markings.

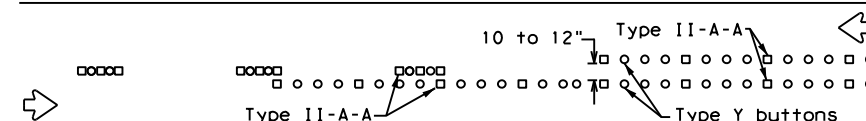

RAISED PAVEMENT MARKERS - PATTERN A

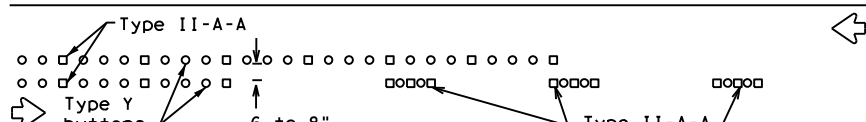

RAISED PAVEMENT MARKERS - PATTERN B

## CENTER LINE & NO-PASSING ZONE BARRIER LINES FOR TWO-LANE, TWO-WAY HIGHWAYS



REFLECTORIZED PAVEMENT MARKINGS

Prefabricated markings may be substituted for reflectORIZED pavement markings.



RAISED PAVEMENT MARKERS

## EDGE & LANE LINES FOR DIVIDED HIGHWAY

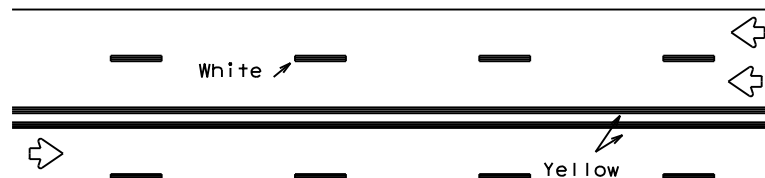

REFLECTORIZED PAVEMENT MARKINGS

Prefabricated markings may be substituted for reflectORIZED pavement markings.

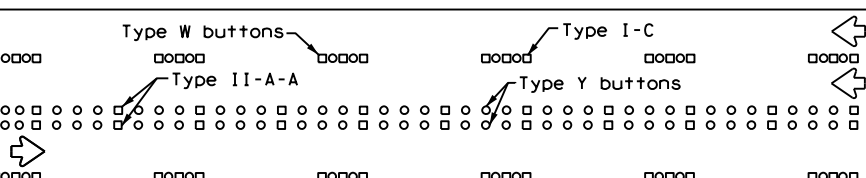

RAISED PAVEMENT MARKERS

## LANE & CENTER LINES FOR MULTILANE UNDIVIDED HIGHWAYS

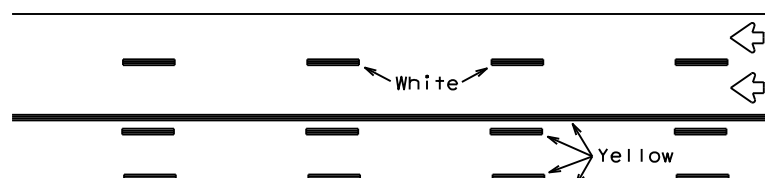

REFLECTORIZED PAVEMENT MARKINGS

Prefabricated markings may be substituted for reflectORIZED pavement markings.

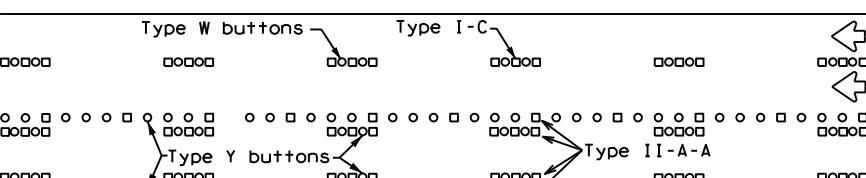

RAISED PAVEMENT MARKERS

## TWO-WAY LEFT TURN LANE

## STANDARD WORK ZONE PAVEMENT MARKINGS DETAILS

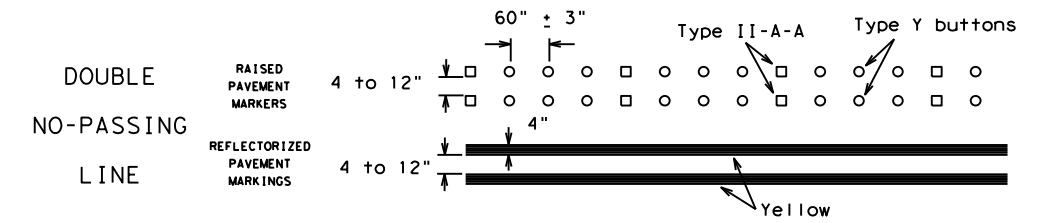

### SOLID LINES

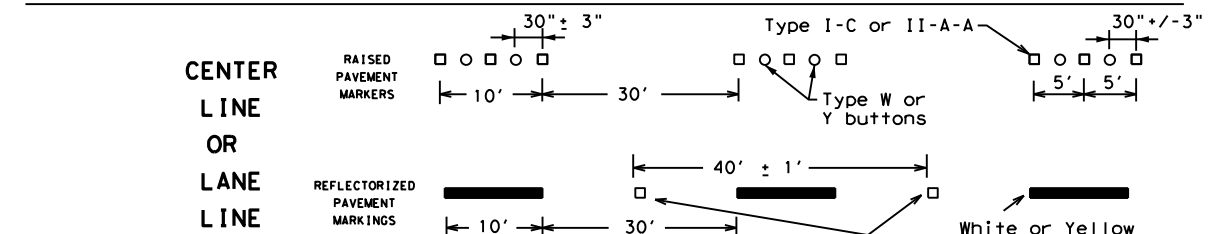
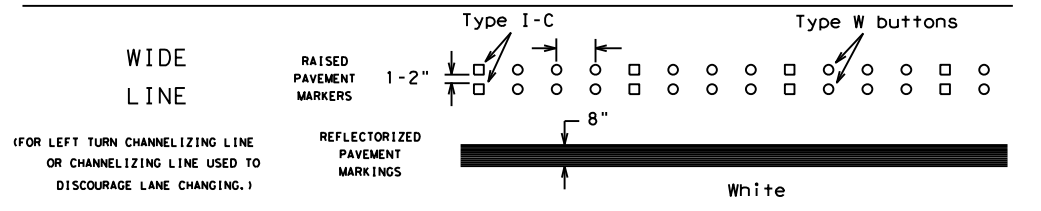
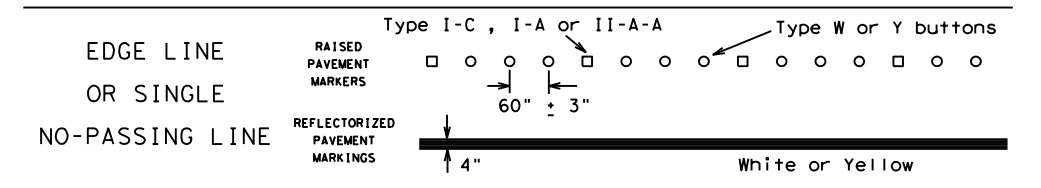

### BROKEN LINES

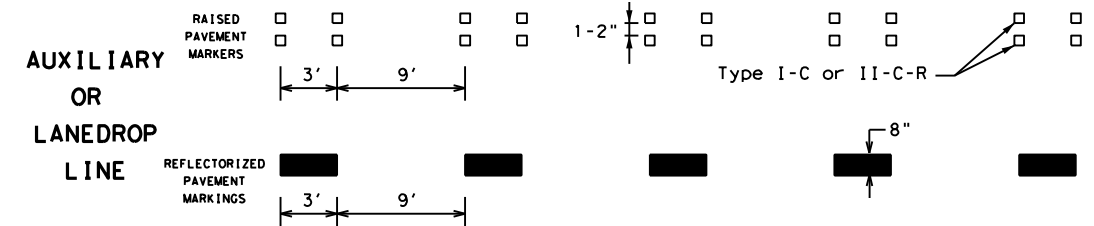

### REMOVABLE MARKINGS WITH RAISED PAVEMENT MARKERS

If raised pavement markers are used to supplement REMOVABLE markings, the markers shall be applied to the top of the tape at the approximate mid length of tape used for broken lines or at 20 foot spacing for solid lines. This allows an easier removal of raised pavement markers and tape.

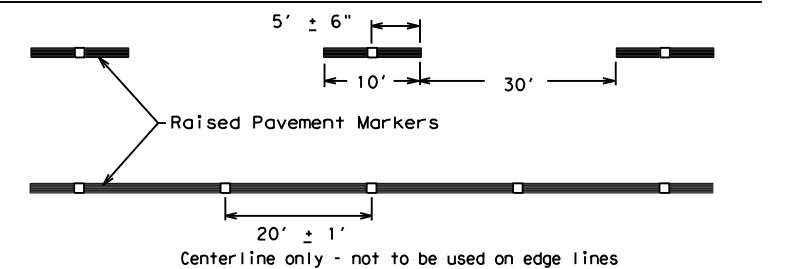

SHEET 12 OF 12



## BARRICADE AND CONSTRUCTION PAVEMENT MARKING PATTERNS

BC(12)-21

FILE: bc-21.dgn	DN: TxDOT	CK: TxDOT	OW: TxDOT	CK: TxDOT
©TxDOT February 1998	CONT	SECT	JOB	HIGHWAY
REVISIONS	0916	28	071	PR 25A
1-97 9-07 5-21				
2-98 7-13				
11-02 8-14	DIST	COUNTY	SHEET NO.	
	CRP	SAN PATRICIO	33	

DISCLAIMER: The use of this standard is governed by the "Texas Engineering Practice Act". No warranty of any kind is made by TxDOT for any purpose whatsoever. TxDOT assumes no responsibility for the conversion of this standard to other formats or for incorrect results or damages resulting from its use.  
 DATE: 1/13/2023 5:16:51 PM  
 FILE: pw://txdot.projectwiseonline.com:TxDOT4/Documents/16 - CRP/Design Projects/091628071/4 - Design/Plan Set/13 - Standards/BC(12)-21.dgn

Raised pavement markers used as standard pavement markings shall be from the approved products list and meet the requirements of Item 672 "RAISED PAVEMENT MARKERS."

DATE: 1/13/2023 5:17:01 PM  
 FILE: \\txdot.projectwiseonline.com:txdot\4\Documents\16 - CRP\Design Projects\16-09-2023\16-09-2023.dgn

DISCLAIMER: The use of this standard is governed by the "Texas Engineering Practice Act". No warranty of any kind is made by TxDOT for any purpose whatsoever. TxDOT assumes no responsibility for the conversion of any information from its use.

Warning Sign Sequence in Opposite Direction Same as Below

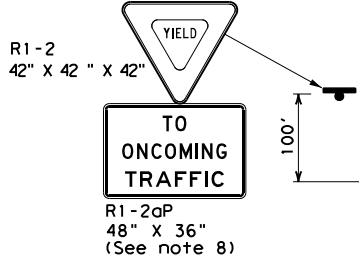

Channelizing devices separate work space from traveled way

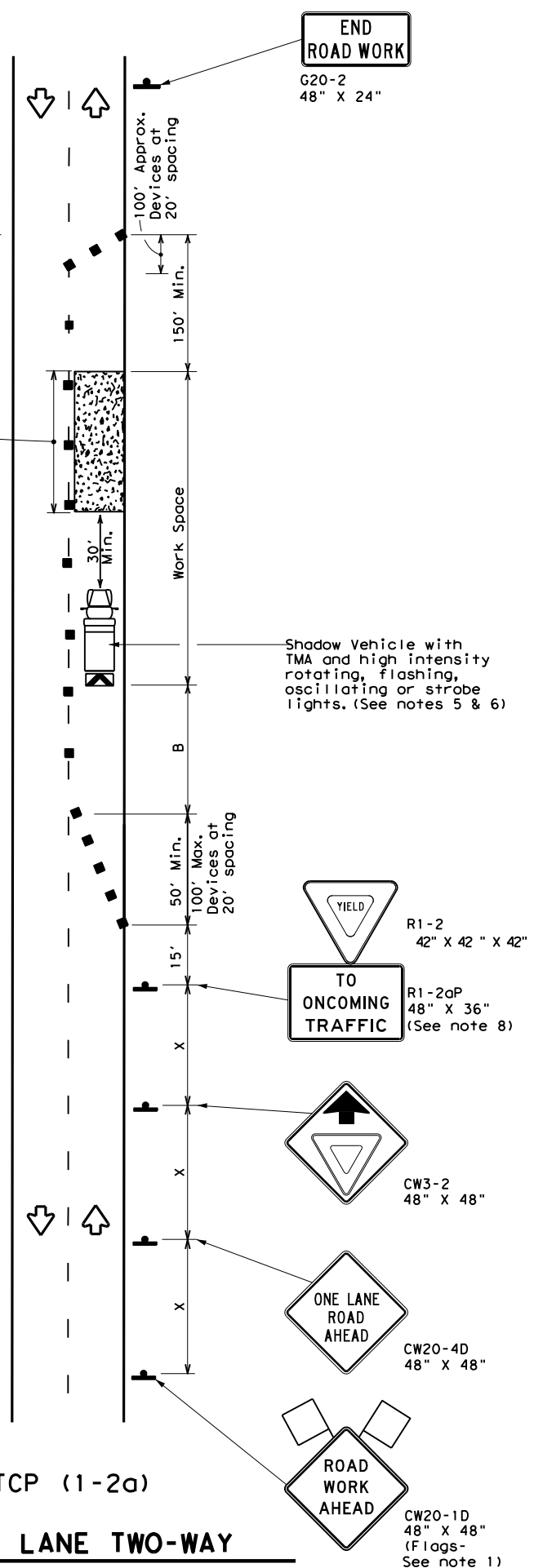

**TCP (1-2a)**  
**ONE LANE TWO-WAY CONTROL WITH YIELD SIGNS**  
 (Less than 2000 ADT - See note 7)

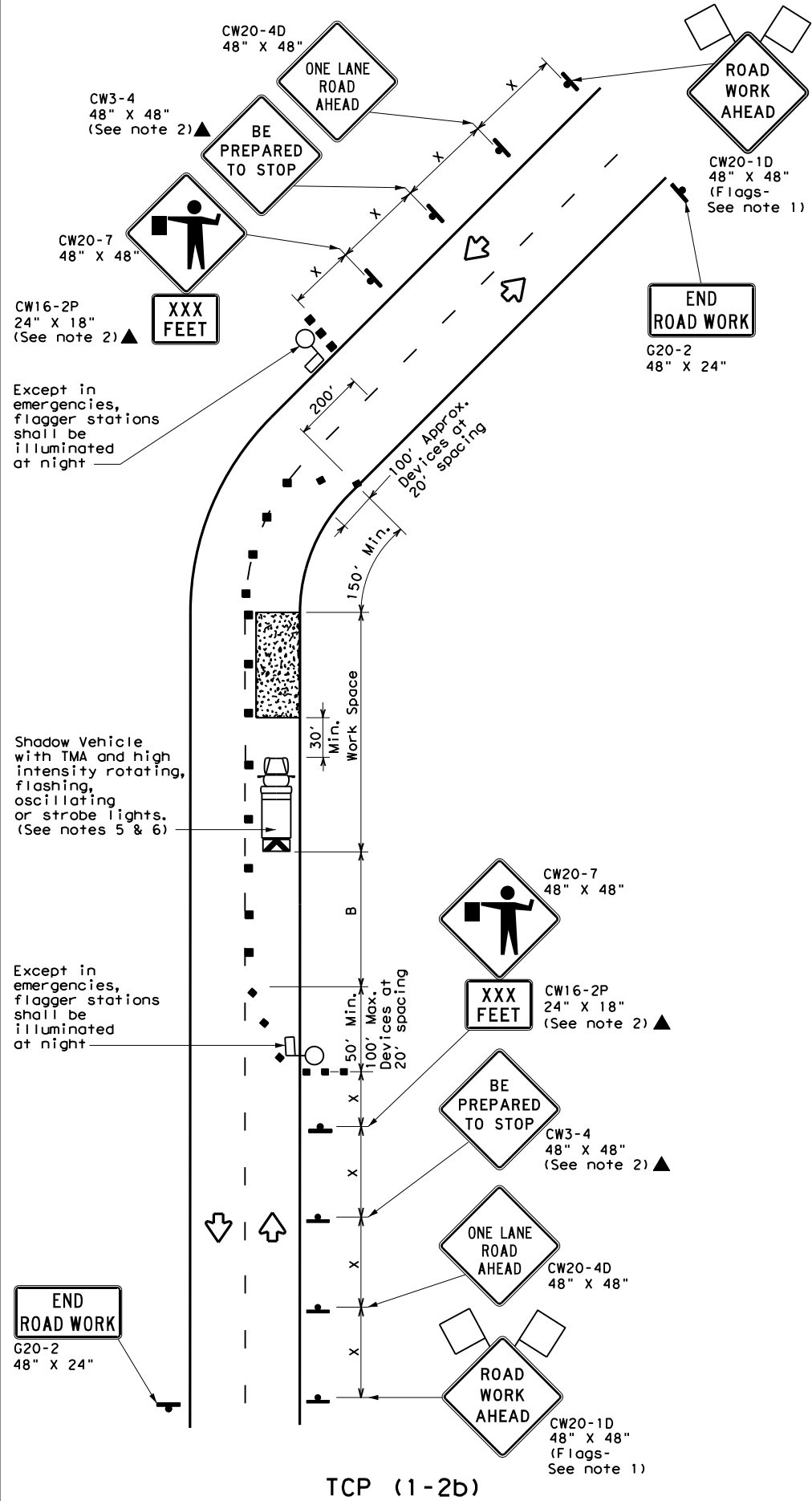

**TCP (1-2b)**  
**ONE LANE TWO-WAY CONTROL WITH FLAGGERS**

LEGEND			
	Type 3 Barricade		Channelizing Devices
	Heavy Work Vehicle		Truck Mounted Attenuator (TMA)
	Trailer Mounted Flashing Arrow Board		Portable Changeable Message Sign (PCMS)
	Sign		Traffic Flow
	Flag		Flagger

Posted Speed * X	Formula L = WS <sup>2</sup> / 60	Minimum Desirable Taper Lengths **			Suggested Maximum Spacing of Channelizing Devices		Minimum Sign Spacing "X" Distance	Suggested Longitudinal Buffer Space "B"	Stopping Sight Distance
		10' Offset	11' Offset	12' Offset	On a Taper	On a Tangent			
30		150'	165'	180'	30'	60'	120'	90'	200'
35		205'	225'	245'	35'	70'	160'	120'	250'
40		265'	295'	320'	40'	80'	240'	155'	305'
45		450'	495'	540'	45'	90'	320'	195'	360'
50		500'	550'	600'	50'	100'	400'	240'	425'
55		550'	605'	660'	55'	110'	500'	295'	495'
60		600'	660'	720'	60'	120'	600'	350'	570'
65		650'	715'	780'	65'	130'	700'	410'	645'
70		700'	770'	840'	70'	140'	800'	475'	730'
75		750'	825'	900'	75'	150'	900'	540'	820'

\* Conventional Roads Only  
 \*\* Taper lengths have been rounded off.  
 L=Length of Taper (FT) W=Width of Offset (FT) S=Posted Speed (MPH)

TYPICAL USAGE				
MOBILE	SHORT DURATION	SHORT TERM STATIONARY	INTERMEDIATE TERM STATIONARY	LONG TERM STATIONARY
	✓	✓		

**GENERAL NOTES**

- Flags attached to signs where shown are REQUIRED.
  - All traffic control devices illustrated are REQUIRED, except those denoted with the triangle symbol may be omitted when stated elsewhere in the plans, or for routine maintenance work, when approved by the Engineer.
  - The CW3-4 "BE PREPARED TO STOP" sign may be installed after the CW20-4D "ONE LANE ROAD AHEAD" sign, but proper sign spacing shall be maintained.
  - Sign spacing may be increased or an additional CW20-1D "ROAD WORK AHEAD" sign may be used if advance warning ahead of the flagger or R1-2 "YIELD" sign is less than 1500 feet.
  - A Shadow Vehicle with a TMA should be used anytime it can be positioned 30 to 100 feet in advance of the area of crew exposure without adversely affecting the performance or quality of the work. If workers are no longer present but road or work conditions require the traffic control to remain in place, Type 3 Barricades or other channelizing devices may be substituted for the Shadow Vehicle and TMA.
  - Additional Shadow Vehicles with TMAs may be positioned off the paved surface, next to those shown in order to protect wider work spaces.
- TCP (1-2a)**
- R1-2 "YIELD" sign traffic control may be used on projects with approaches that have adequate sight distance. For projects in urban areas, work spaces should be no longer than one half city block. In rural areas on roadways with less than 2000 ADT, work spaces should be no longer than 400 feet.
  - R1-2 "YIELD" sign with R1-2aP "TO ONCOMING TRAFFIC" plaque shall be placed on a support at a 7 foot minimum mounting height.
- TCP (1-2b)**
- Flaggers should use two-way radios or other methods of communication to control traffic.
  - Length of work space should be based on the ability of flaggers to communicate.
  - If the work space is located near a horizontal or vertical curve, the buffer distances should be increased in order to maintain adequate stopping sight distance to the flagger and a queue of stopped vehicles (see table above).
  - Channelizing devices on the center-line may be omitted when a pilot car is leading traffic and approved by the Engineer.
  - Flaggers should use 24" STOP/SLOW paddles to control traffic. Flags should be limited to emergency situations.

Texas Department of Transportation  
 Traffic Operations Division Standard

## TRAFFIC CONTROL PLAN ONE-LANE TWO-WAY TRAFFIC CONTROL

### TCP (1-2) - 18

FILE: tcp1-2-18.dgn	DN:	CK:	DW:	CK:
© TxDOT December 1985	CONT	SECT	JOB	HIGHWAY
REVISIONS	0916	28	071	PR 25A
4-90 4-98	DIST	COUNTY	SHEET NO.	
2-94 2-12	CRP	SAN PATRICIO	34	
1-97 2-18				

DISCLAIMER: The use of this standard is governed by the "Texas Engineering Practice Act". No warranty of any kind is made by TxDOT for any purpose whatsoever. TxDOT assumes no responsibility for the conversion of units or for the use of this standard in any project. The user of this standard is advised to consult the Texas Engineering Practice Act and the Texas Transportation Code for any changes or updates to this standard. DATE: 1/13/2023 5:17:12 PM FILE: pw://txdot.projectwiseonline.com:txdot4/Documents/16 - CRP/Design Projects/16-000001/16-000001.dgn

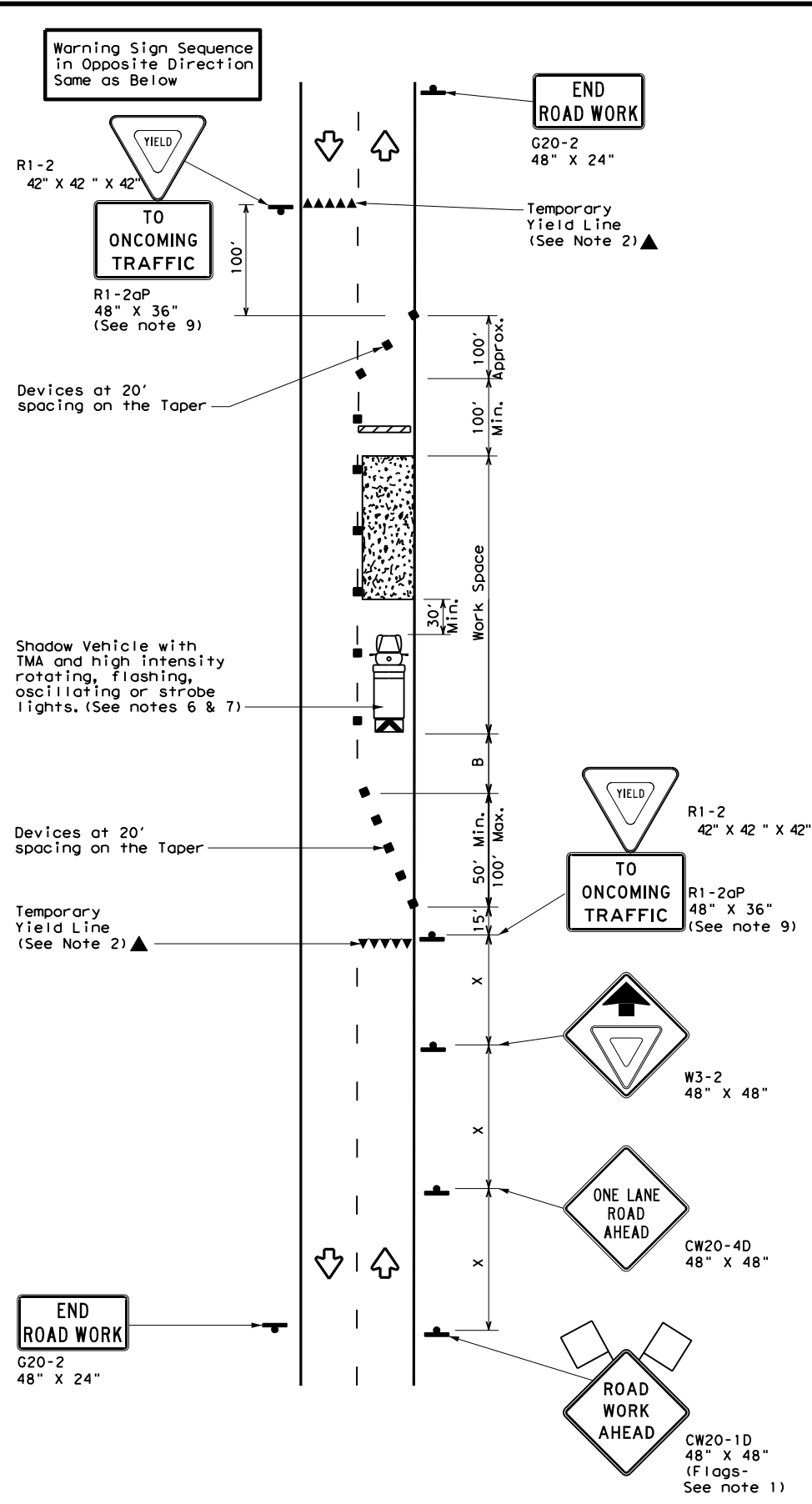

TCP (2-2a)  
2-LANE ROADWAY WITHOUT PAVED SHOULDERS  
ONE LANE TWO-WAY  
CONTROL WITH YIELD SIGNS  
(Less than 2000 ADT - See Note 9)

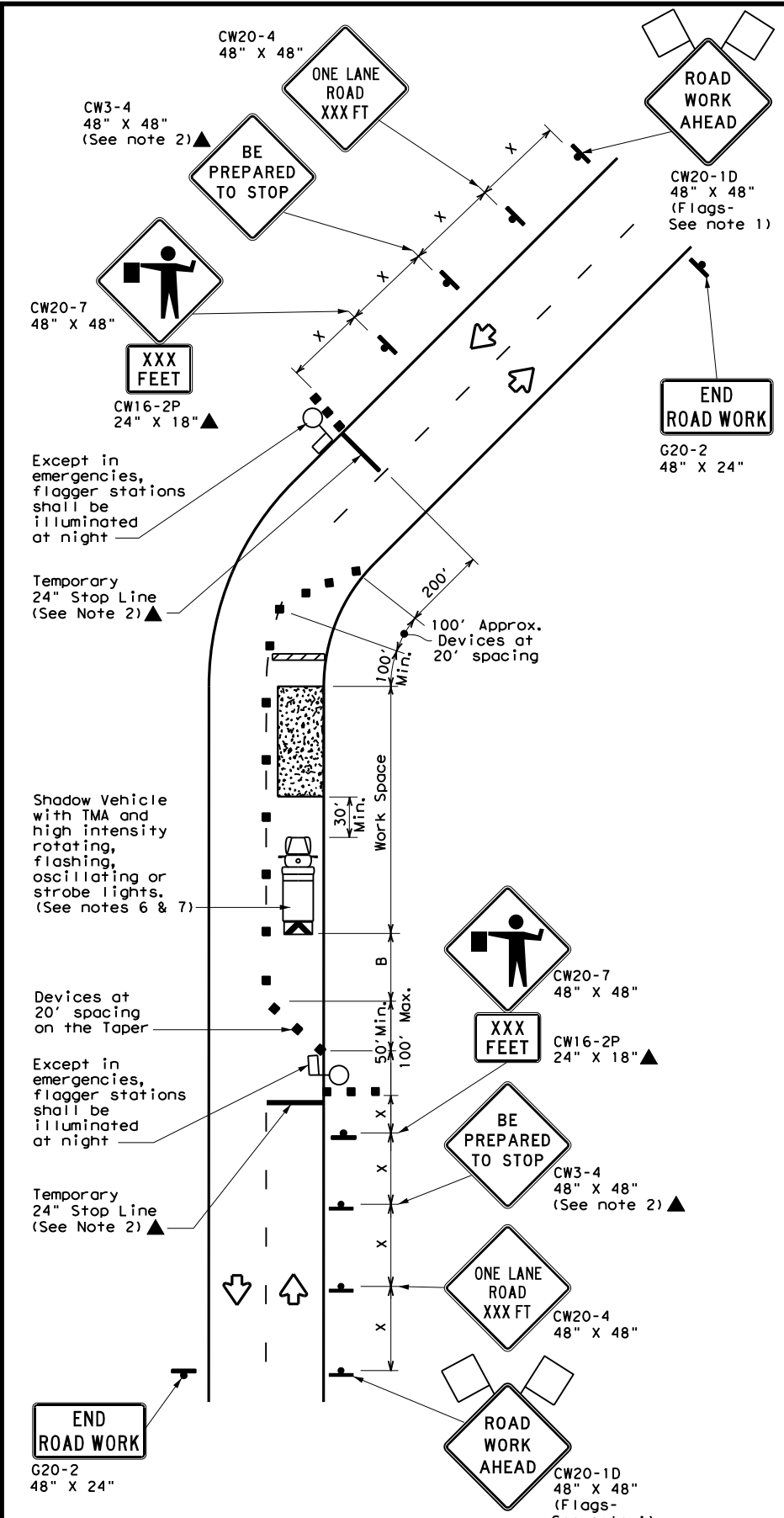

TCP (2-2b)  
2-LANE ROADWAY WITHOUT PAVED SHOULDERS  
ONE LANE TWO-WAY  
CONTROL WITH FLAGGERS

LEGEND			
	Type 3 Barricade		Channelizing Devices
	Heavy Work Vehicle		Truck Mounted Attenuator (TMA)
	Trailer Mounted Flashing Arrow Board		Portable Changeable Message Sign (PCMS)
	Sign		Traffic Flow
	Flag		Flagger

Posted Speed *	Formula	Minimum Desirable Taper Lengths **			Suggested Maximum Spacing of Channelizing Devices		Minimum Sign Spacing "X" Distance	Suggested Longitudinal Buffer Space "B"	Stopping Sight Distance
		10' Offset	11' Offset	12' Offset	On a Taper	On a Tangent			
30	L = WS <sup>2</sup> / 60	150'	165'	180'	30'	60'	120'	90'	200'
35		205'	225'	245'	35'	70'	160'	120'	250'
40		265'	295'	320'	40'	80'	240'	155'	305'
45	L = WS	450'	495'	540'	45'	90'	320'	195'	360'
50		500'	550'	600'	50'	100'	400'	240'	425'
55		550'	605'	660'	55'	110'	500'	295'	495'
60		600'	660'	720'	60'	120'	600'	350'	570'
65		650'	715'	780'	65'	130'	700'	410'	645'
70		700'	770'	840'	70'	140'	800'	475'	730'
75		750'	825'	900'	75'	150'	900'	540'	820'

\* Conventional Roads Only  
 \*\* Taper lengths have been rounded off.  
 L=Length of Taper (FT) W=Width of Offset (FT) S=Posted Speed (MPH)

TYPICAL USAGE				
MOBILE	SHORT DURATION	SHORT TERM STATIONARY	INTERMEDIATE TERM STATIONARY	LONG TERM STATIONARY
	✓	✓	✓	

GENERAL NOTES

- Flags attached to signs where shown, are REQUIRED.
  - All traffic control devices illustrated are REQUIRED, except those denoted with the triangle symbol may be omitted when stated elsewhere in the plans, or for routine maintenance work, when approved by the Engineer.
  - The CW3-4 "BE PREPARED TO STOP" sign may be installed after the CW20-4 "ONE LANE ROAD XXX FT" sign, but proper sign spacing shall be maintained.
  - Flaggers should use two-way radios or other methods of communication to control traffic.
  - Length of work space should be based on the ability of flaggers to communicate.
  - A Shadow Vehicle with a TMA should be used anytime it can be positioned 30 to 100 feet in advance of the area of crew exposure without adversely affecting the performance or quality of the work. If workers are no longer present but road or work conditions require the traffic control to remain in place, Type 3 Barricades or other channelizing devices may be substituted for the Shadow Vehicle and TMA.
  - Additional Shadow Vehicles with TMAs may be positioned off the paved surface, next to those shown in order to protect a wider work space.
- TCP (2-2a)
- The R1-2 "YIELD" sign traffic control may be used on projects with approaches that have adequate sight distance. For projects in urban areas, work space should be no longer than one half city block. In rural areas, roadways with less than 2000 ADT, work space should be no longer than 400 feet.
  - The R1-2aP "YIELD TO ONCOMING TRAFFIC" sign shall be placed on a support at a 7 foot minimum mounting height.
- TCP (2-2b)
- Channelizing devices on the center line may be omitted when a pilot car is leading traffic and approved by the Engineer.
  - If the work space is located near a horizontal or vertical curve, the buffer distances should be increased in order to maintain stopping sight distance to the flagger and a queue of stopped vehicles. (See table above).
  - Flaggers should use 24" STOP/SLOW paddles to control traffic. Flags should be limited to emergency situations.

		Traffic Operations Division Standard	
<b>TRAFFIC CONTROL PLAN</b> <b>ONE-LANE TWO-WAY</b> <b>TRAFFIC CONTROL</b>			
<b>TCP (2-2) - 18</b>			
FILE:	tcp2-2-18.dgn	DN:	CK:
© TxDOT	December 1985	CONT	SECT
REVISIONS	0916	28	071
8-95	3-03		
1-97	2-12		
4-98	2-18		
DIST	COUNTY		SHEET NO.
CRP	SAN PATRICIO		35



DISCLAIMER: The use of this standard is governed by the "Texas Engineering Practice Act". No warranty of any kind is made by TxDOT for any purpose whatsoever. TxDOT assumes no responsibility for the conversion of this standard to other formats or for incorrect results or damages resulting from its use.

DATE: 1/13/2023 5:17:21 PM  
 FILE: pw:///txdot.projectwiseonline.com:txdot4/Documents/16 - CRP/Design Projects/091628071/4 - Design/Plan Set/13. Standards/TCP(S-1)-08A.dgn

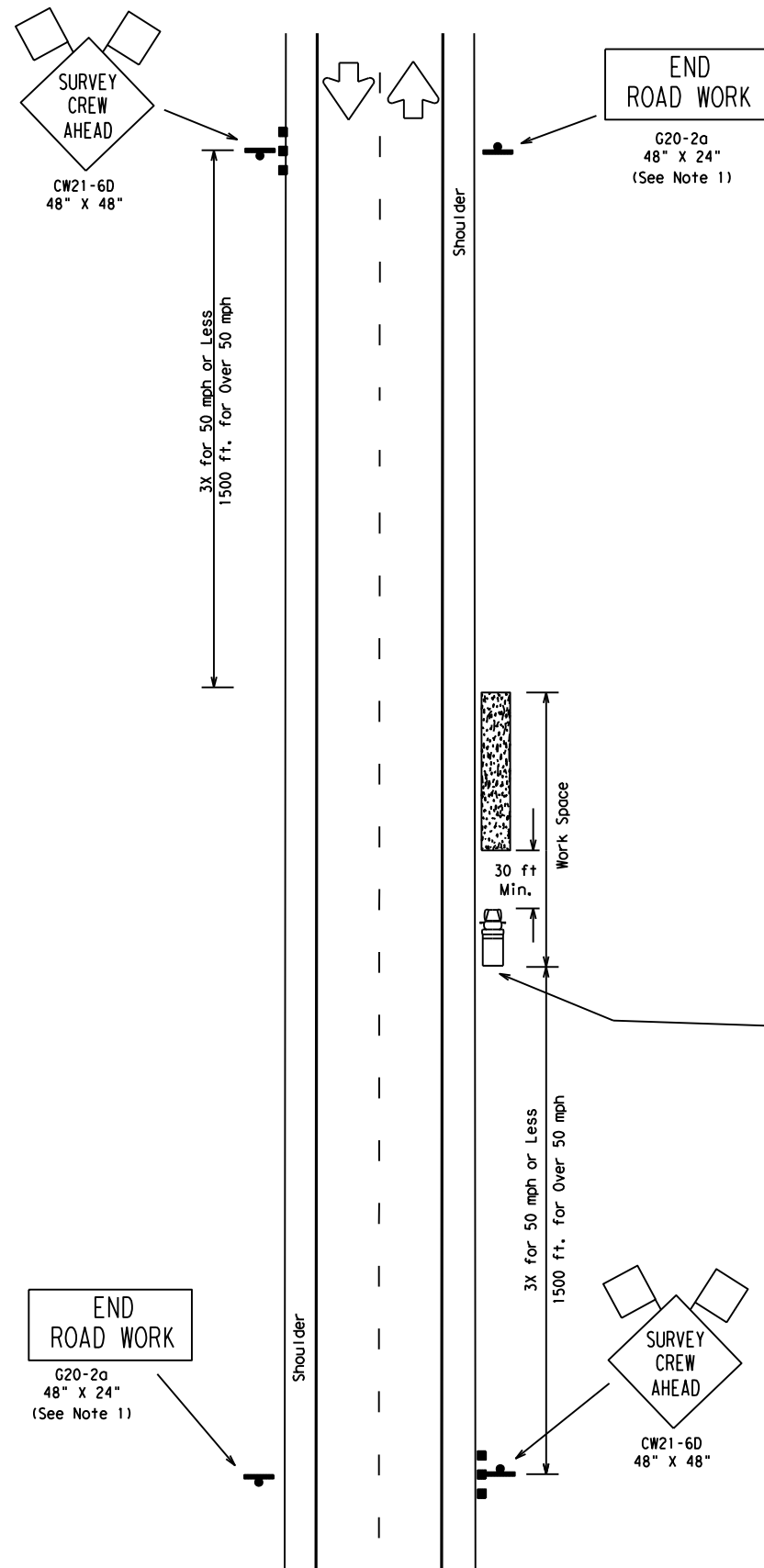

TCP (S-1a)  
 WORK OFF SHOULDER  
 OR PAVED SURFACE

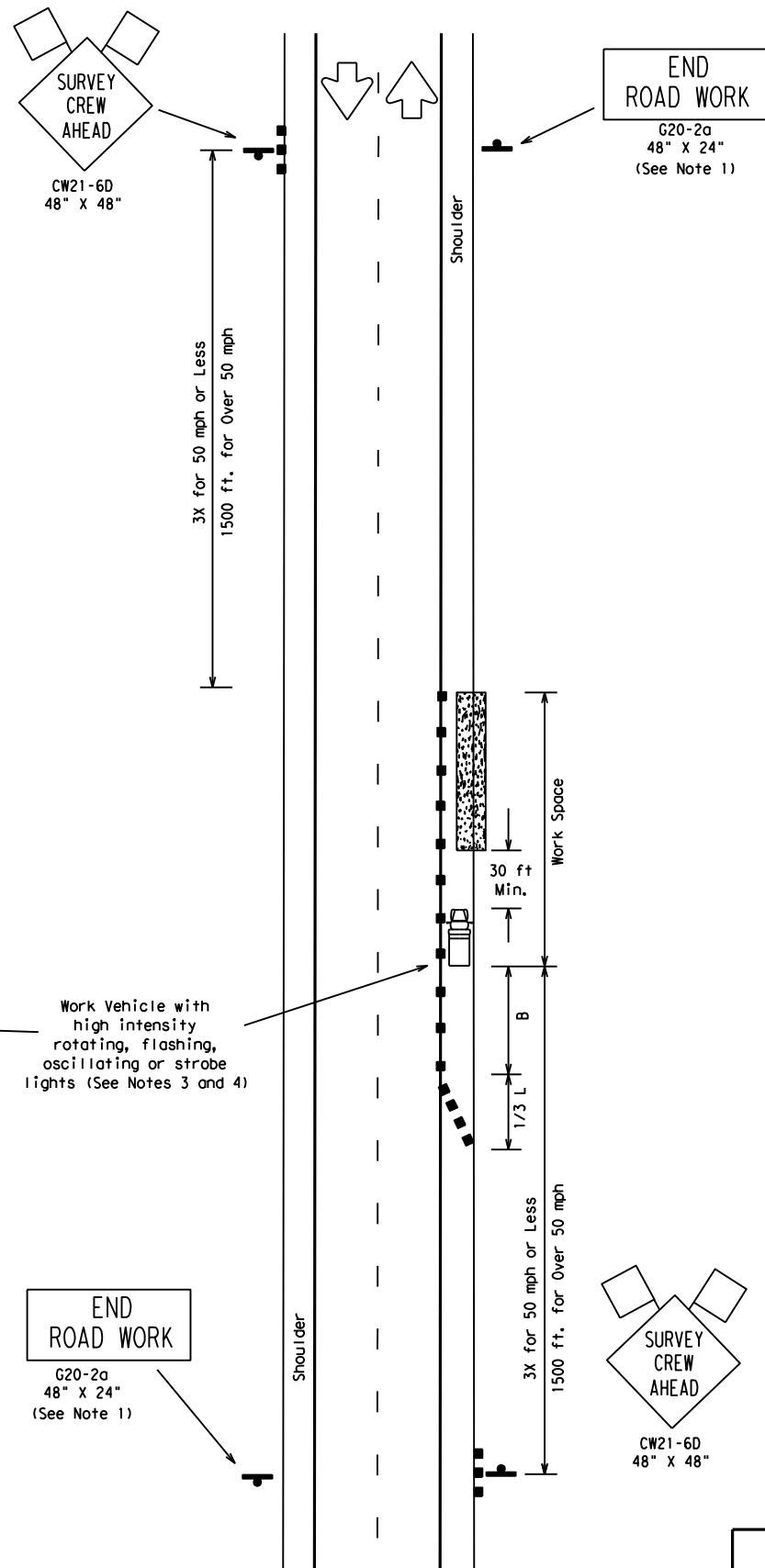

TCP (S-1b)  
 WORK ON SHOULDER

WHENEVER POSSIBLE, SURVEY PARTIES SHOULD AVOID, BY THE USE OF OFFSET LINES, ANY UNNECESSARY PERIODS OF TIME ON THE ROAD SURFACE.

8-18-08 Revision  
 Corrected misspelling.

LEGEND

	Type III Barricade		Channelizing Devices		Flag
	Heavy Work Vehicle		Truck Mounted Attenuator (TMA)		
	Trailer Mounted Flashing Arrow Panel		Portable Changeable Message Sign (PCMS)		
	Flagger		Sign Post		

Posted Speed *	Formula	Minimum Desirable Taper Lengths **			Suggested Maximum Spacing of Device		Min. Sign Spacing "X" Distance	Longitudinal Buffer Space "B"
		10' Offset	11' Offset	12' Offset	On a Taper	On a Tangent		
30	$L = \frac{WS^2}{60}$	150'	165'	180'	30'	60' - 75'	120'	90'
35		205'	225'	245'	35'	70' - 90'	160'	120'
40		265'	295'	320'	40'	80' - 100'	240'	155'
45		450'	495'	540'	45'	90' - 110'	320'	195'
50		500'	550'	600'	50'	100' - 125'	400'	240'
55		550'	605'	660'	55'	110' - 140'	500'	295'
60		600'	660'	720'	60'	120' - 150'	600'	350'
65	650'	715'	780'	65'	130' - 165'	700'	410'	
70	700'	770'	840'	70'	140' - 175'	800'	475'	
75	750'	825'	900'	75'	150' - 185'	900'	540'	

\* Conventional Roads Only  
 \*\* Taper lengths have been rounded off.  
 L=Length of Taper (FT.) W=Width of Offset (FT.) S=Posted Speed (MPH)

TYPICAL USAGE:

MOBILE	SHORT DURATION	SHORT TERM STATIONARY	INTERMEDIATE TERM STATIONARY	LONG TERM STATIONARY
	✓	✓		

DEFINITIONS:  
 SHORT DURATION - work that occupies a location up to 1 hour.  
 SHORT TERM STATIONARY - daytime work that occupies a location for more than 1 hour within a single daylight period.

- GENERAL NOTES:
- The G20-2a "END ROAD WORK" sign may be placed on the back of the CW21-6D "SURVEY CREW AHEAD" sign or may be omitted for short duration (less than 1 hour) work.
  - Channelizing devices on the shoulder taper and tangent section may be omitted for short duration (less than 1 hour) work.
  - If line-of-sight requirements for surveying operations will preclude the placement of the Work Vehicle to protect workers, the channelizing devices mentioned in Note 2 are required.
  - A Shadow Vehicle with a Truck Mounted Attenuator and flashing warning lights/arrow panel in caution mode may be used in lieu of the Work Vehicle to protect the work space.
  - The CW20-1D "ROAD WORK AHEAD" sign may be substituted for the CW21-6D "SURVEY CREW AHEAD" sign.
  - This plan may also be used for shoulder work or off shoulder work for multilane undivided roadways.
  - The CW21-6D "SURVEY CREW AHEAD" sign for low volume intersecting side roads is desirable, but is not required when working less than 15 minutes in area of the side road, as determined by the Engineer.

- TCP (S-1a)
- Cones may be placed at edge of pavement adjacent to the work space to enhance safety.

**Texas Department of Transportation**  
 Traffic Operations Division

**TRAFFIC CONTROL PLAN FOR SURVEYING OPERATIONS**

**TCP (S-1) -08A**

© TxDOT August 2008		DN: TxDOT	CK: TxDOT	DW: TxDOT	CK: TxDOT
8-08	REVISIONS	CONT	SECT	JOB	HIGHWAY
		0916	28	071	PR 25A
		DIST	COUNTY	SHEET NO.	
		CRP	SAN PATRICIO	36	

DISCLAIMER: The use of this standard is governed by the "Texas Engineering Practice Act". No warranty of any kind is made by TxDOT for any purpose whatsoever. TxDOT assumes no responsibility for the conversion of this standard to other formats or for incorrect results or damages resulting from its use.

DATE: 1/13/2023 5:17:30 PM  
 FILE: pw://txdot.projectwiseonline.com:1628071/4 - CRP/Design Projects/091628071/4 - Design/Plan Set/13 - Standards/TCP(S-2) - 08A.dgn

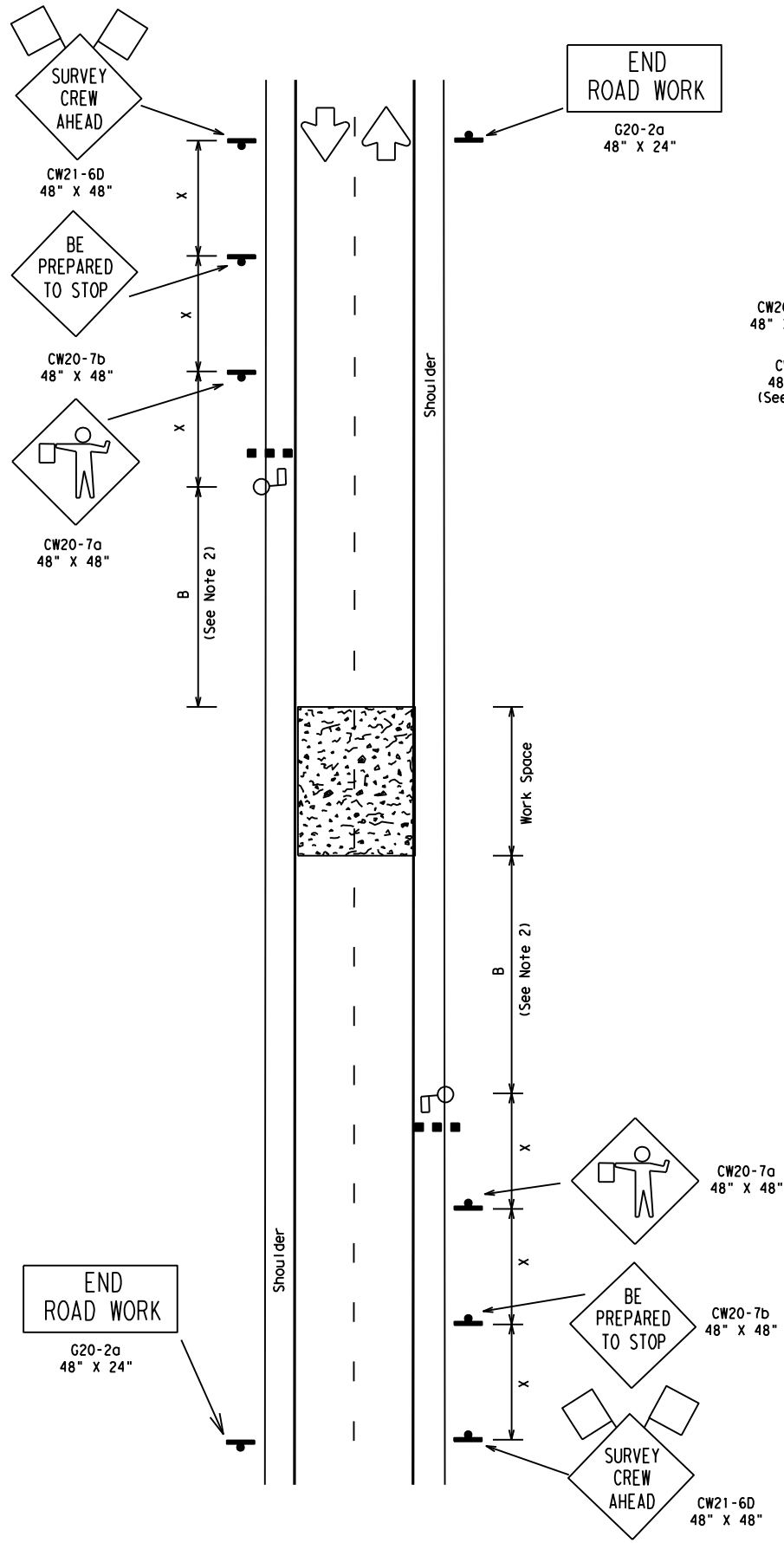

TCP (S-2a)  
 ROAD CLOSED FOR LESS THAN 20 MINUTES -  
 OFF PEAK TRAFFIC HOURS  
 WITH OR WITHOUT SHOULDERS

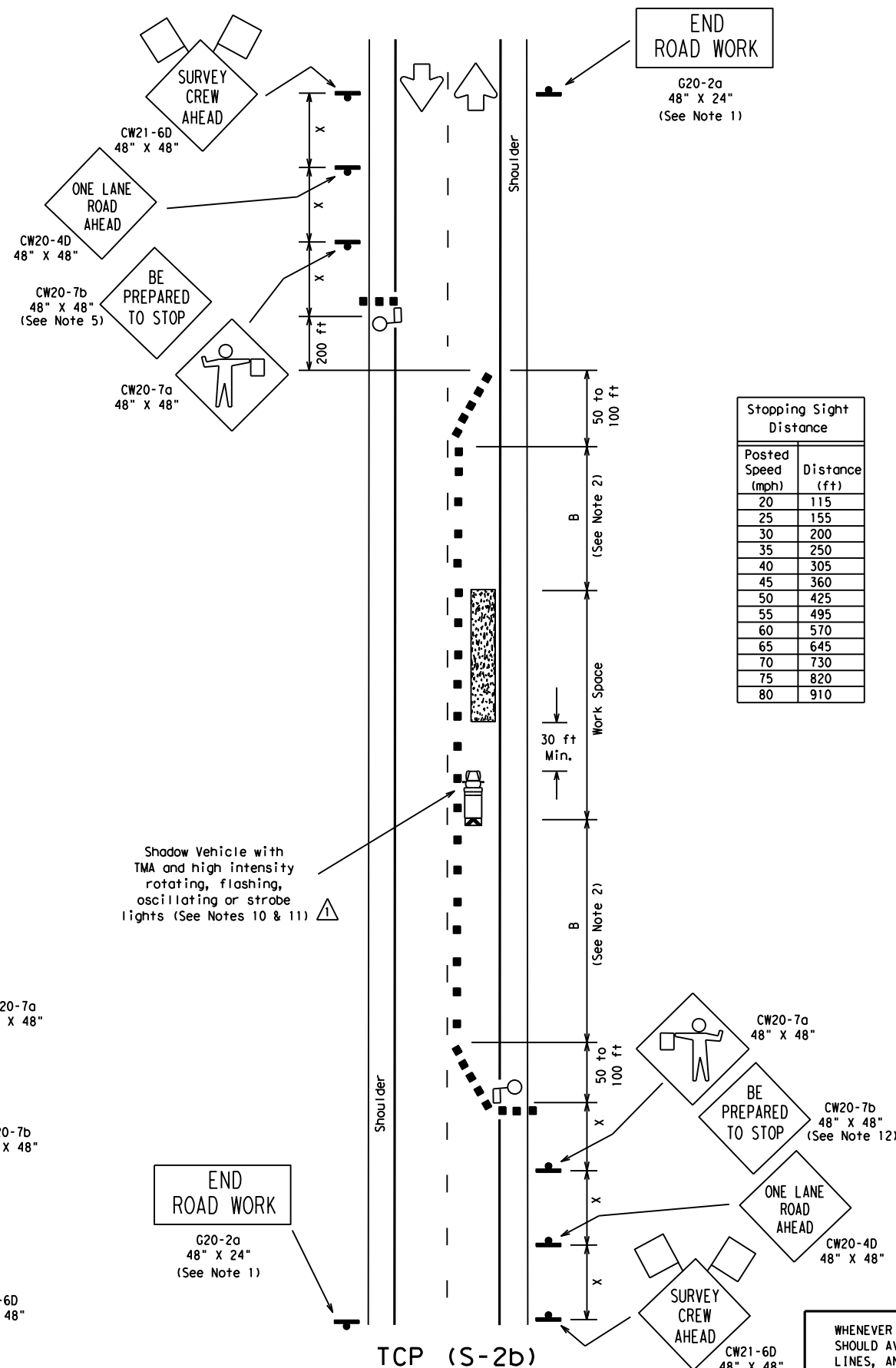

TCP (S-2b)  
 WORK IN ROADWAY  
 OFF PEAK TRAFFIC HOURS  
 WITH OR WITHOUT SHOULDERS

Posted Speed (mph)	Distance (ft)
20	115
25	155
30	200
35	250
40	305
45	360
50	425
55	495
60	570
65	645
70	730
75	820
80	910

LEGEND

- Type III Barricade
- Channelizing Devices
- Flag
- Heavy Work Vehicle
- Truck Mounted Attenuator (TMA)
- Trailer Mounted Flashing Arrow Panel
- Portable Changeable Message Sign (PCMS)
- Flagger
- Sign Post

Posted Speed $\times$	Formula	Minimum Desirable Taper Lengths $\times$			Suggested Maximum Spacing of Device		Min. Sign Spacing "x" Distance	Longitudinal Buffer Space "B"
		10' Offset	11' Offset	12' Offset	On a Taper	On a Tangent		
30	$L = \frac{WS^2}{60}$	150'	165'	180'	30'	60'-75'	120'	90'
35		205'	225'	245'	35'	70'-90'	160'	120'
40		265'	295'	320'	40'	80'-100'	240'	155'
45		450'	495'	540'	45'	90'-110'	320'	195'
50		500'	550'	600'	50'	100'-125'	400'	240'
55	$L = WS$	550'	605'	660'	55'	110'-140'	500'	295'
60		600'	660'	720'	60'	120'-150'	600'	350'
65		650'	715'	780'	65'	130'-165'	700'	410'
70		700'	770'	840'	70'	140'-175'	800'	475'
75		750'	825'	900'	75'	150'-185'	900'	540'

\* Conventional Roads Only  
 \*\* Taper lengths have been rounded off.  
 L=Length of Taper (FT.) W=Width of Offset (FT.) S=Posted Speed (MPH)

TYPICAL USAGE:				
MOBILE	SHORT DURATION	SHORT TERM STATIONARY	INTERMEDIATE TERM STATIONARY	LONG TERM STATIONARY
	✓	✓		

DEFINITIONS:  
 SHORT DURATION - work that occupies a location up to 1 hour.  
 SHORT TERM STATIONARY - daytime work that occupies a location for more than 1 hour within a single daylight period.

- GENERAL NOTES:
- The G20-2a "END ROAD WORK" sign may be placed on the back of the CW21-6D "SURVEY CREW AHEAD" sign or may be omitted for short duration (less than 1 hour) work.
  - Adequate Stopping Sight Distance (see Stopping Sight Distance table) should be maintained from approaching traffic to the flagger or a queue of stopped vehicles. The Buffer Space "B" should be extended around curves or other obstacles, when necessary, to have adequate Stopping Sight Distance to the flagger station.
  - Flaggers should use two-way radios or other means of communication while flagging.
  - The length of the work space should be based on the ability of the flaggers to communicate.
  - CW20-1D "ROAD WORK AHEAD" signs may be substituted for CW21-6D "SURVEY CREW AHEAD" signs.
  - The CW21-6D "SURVEY CREW AHEAD" sign for low volume intersecting side roads is desirable, but is not required when working less than 15 minutes in area of the side road, as determined by the Engineer.
- TCP (S-2a)
- Road closures shall be less than 20 minutes. Closures less than 5 minutes are desirable.
  - Sign spacing should be increased if traffic repeatedly queues past the CW20-7b "BE PREPARED TO STOP" sign.
  - The surveying instrument should not be located on the paved surface.
- TCP (S-2b)
- For short duration work the Shadow Vehicle with a TMA may be replaced by another Work Vehicle with high intensity rotating, flashing or strobe lights.
  - Shadow Vehicles with a TMA are desirable when workers or equipment are in the work space. When approved by the engineer, Type III barricades or other channelizing devices may be substituted for the Shadow Vehicle.
  - The CW20-7b "BE PREPARED TO STOP" sign is optional. When used, it should be installed after the CW20-4D "ONE LANE ROAD AHEAD" sign.

WHENEVER POSSIBLE, SURVEY PARTIES SHOULD AVOID, BY THE USE OF OFFSET LINES, ANY UNNECESSARY PERIODS OF TIME ON THE ROAD SURFACE.

8-18-08 Revision  
 Corrected reference to notes.

Texas Department of Transportation  
 Traffic Operations Division

### TRAFFIC CONTROL PLAN FOR SURVEYING OPERATIONS

TCP (S-2) - 08A

© TxDOT August 2008	DN: TxDOT	CK: TxDOT	DW: TxDOT	CK: TxDOT
8-08	REVISONS	CONT	SECT	JOB
		0916	28	071
	DIST	COUNTY	SHEET NO.	
	CRP	SAN PATRICIO	37	

DATE: 1/13/2023 5:17:41 PM  
 FILE: pw://txdot.projectwiseonline.com:txdot4/Documents/16 - CRP/Design Projects/091628071/4 - Design/Plan Set/13. Standards/TCP(S-2c)-10.dgn

DISCLAIMER:

The use of this standard is governed by the "Texas Engineering Practice Act". No warranty of any kind is made by TxDOT for any purpose whatsoever. TxDOT assumes no responsibility for the conversion of this standard to other formats or for incorrect results or damages resulting from its use.

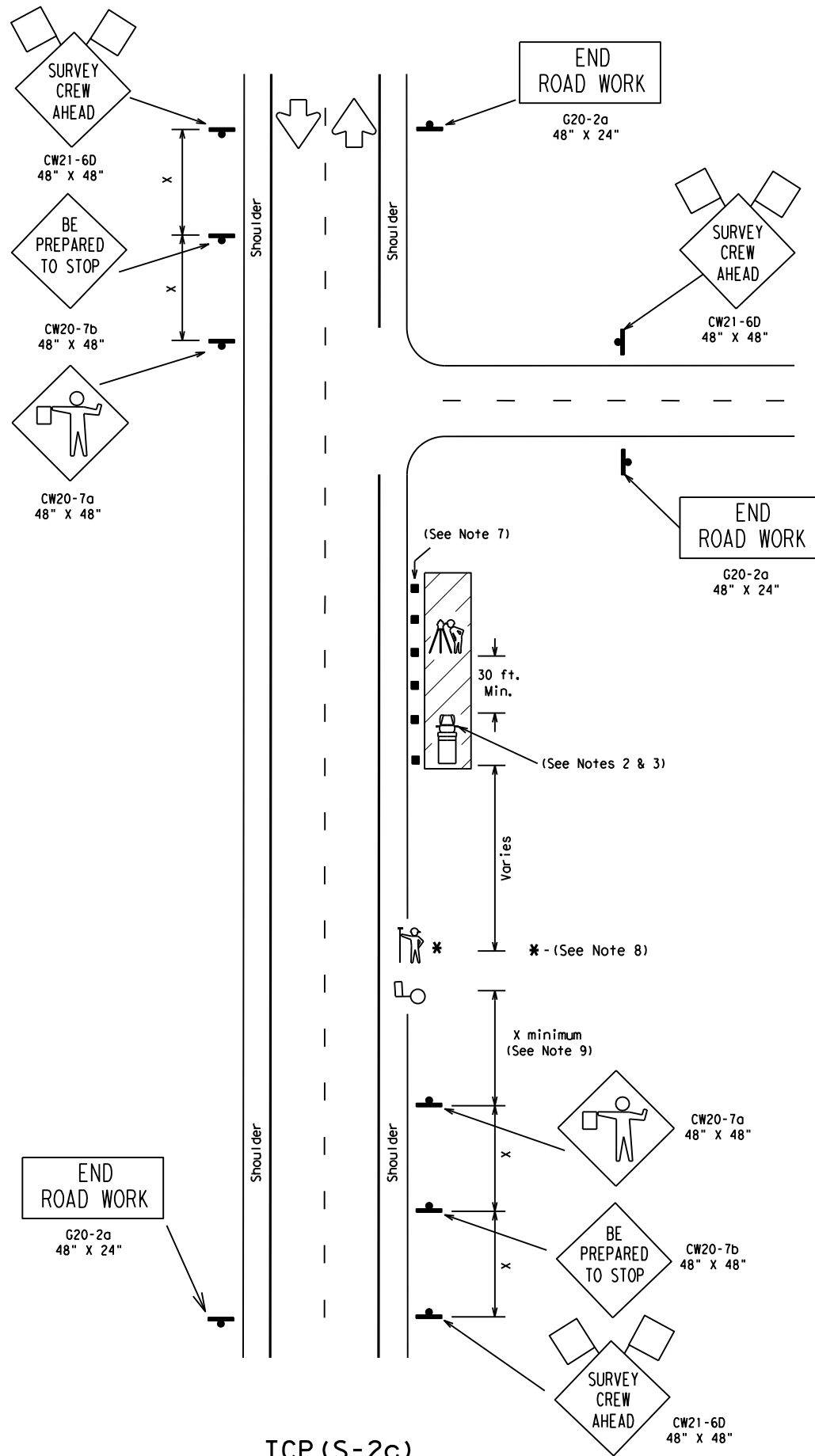

TCP (S-2c)

Posted Speed (mph)	Distance (ft)
20	115
25	155
30	200
35	250
40	305
45	360
50	425
55	495
60	570
65	645
70	730
75	820
80	910

LEGEND

- Type III Barricade
- Channelizing Devices
- Flag
- Work Vehicle
- Truck Mounted Attenuator (TMA)
- Flagger
- Sign Post
- Survey Rodman
- Instrument Person

Posted Speed %	Formula	Minimum Desirable Taper Lengths **			Suggested Maximum Spacing of Device		Min. Sign Spacing "x" Distance	Longitudinal Buffer Space "B"
		10' Offset	11' Offset	12' Offset	On a Taper	On a Tangent		
30	$L = \frac{WS^2}{60}$	150'	165'	180'	30'	60' - 75'	120'	90'
35		205'	225'	245'	35'	70' - 90'	160'	120'
40		265'	295'	320'	40'	80' - 100'	240'	155'
45	L=WS	450'	495'	540'	45'	90' - 110'	320'	195'
50		500'	550'	600'	50'	100' - 125'	400'	240'
55		550'	605'	660'	55'	110' - 140'	500'	295'
60		600'	660'	720'	60'	120' - 150'	600'	350'
65		650'	715'	780'	65'	130' - 165'	700'	410'
70		700'	770'	840'	70'	140' - 175'	800'	475'
75		750'	825'	900'	75'	150' - 185'	900'	540'

\* Conventional Roads Only  
 \*\* Taper lengths have been rounded off.  
 L=Length of Taper (FT.) W=Width of Offset (FT.) S=Posted Speed (MPH)

	SHORT DURATION	SHORT TERM STATIONARY	INTERMEDIATE TERM STATIONARY	LONG TERM STATIONARY
MOBILE	✓	✓		

DEFINITIONS:  
 MOBILE - work that moves continuously or intermittently (stopping up to approximately 15 minutes).  
 SHORT DURATION - work that occupies a location up to 1 hour.  
 SHORT TERM STATIONARY - daytime work that occupies a location for more than 1 hour within a single daylight period.

- GENERAL NOTES:
- The G20-2a "END ROAD WORK" sign may be placed on the back of the CW21-6D "SURVEY CREW AHEAD" sign or may be omitted for short duration (less than 1 hour) work.
  - Work Vehicle with high intensity rotating, flashing, oscillating or strobe lights should be used to protect work space.
  - When approved by the engineer, Type III barricades or other channelizing devices may be substituted for the Heavy Work Vehicle.
  - CW20-1D "ROAD WORK AHEAD" signs may be substituted for CW21-6D "SURVEY CREW AHEAD" SIGNS.
  - The CW21-6D "SURVEY CREW AHEAD" sign for low volume intersecting side roads may be omitted when approved by the Engineer.
  - The Surveying Instrument shall not be located on the paved surface.
  - Cones at edge of pavement adjacent to instrument person may be omitted when approved by the Engineer.
  - Rodman may only enter roadway when accompanied by flagger and as traffic allows.
  - The distance between the advance warning signs and the work should not exceed a two mile maximum.
  - Flaggers and Survey Crew should use two-way radios or other means of communication.
  - Survey Crew and Flaggers shall wear high-visibility apparel meeting the ANSI 107-2007 standard performance for Class 2 or Class 3 risk exposure.
  - Additional traffic control devices may be required to address local site conditions.
  - Stopping Sight Distance shall be maintained from approaching traffic to the flagger. See "Stopping Sight Distance" table.

SURVEY PARTIES SHOULD AVOID ANY UNNECESSARY PERIODS OF TIME ON THE ROAD SURFACE.

This TCP is to cover two lane rural type roadways as determined by the Engineer. All other type roadways will be covered by other established Survey TCP'S.

**Texas Department of Transportation**  
 Traffic Operations Division

**TRAFFIC CONTROL PLAN FOR SURVEYING OPERATIONS**

**TCP (S-2c) - 10**

© TxDOT January 2010		DN: TXDOT	CK: TXDOT	DW: TXDOT	CK: TXDOT
REVISIONS		CONT	SECT	JOB	HIGHWAY
		0916	28	071	PR 25A
		DIST	COUNTY		SHEET NO.
		CRP	SAN PATRICIO		38

DISCLAIMER: The use of this standard is governed by the "Texas Engineering Practice Act". No warranty of any kind is made by TxDOT for any purpose whatsoever. TxDOT assumes no responsibility for the conversion of units or for the accuracy of the information provided. For more information, please refer to the Texas Department of Transportation website at [www.txdot.gov](http://www.txdot.gov).

DATE: 1/13/2023 5:17:49 PM  
 FILE: \\txdot.projectwiseonline.com:txdot14\Documents\16 - CRP\Design Projects\091628\091628.dgn

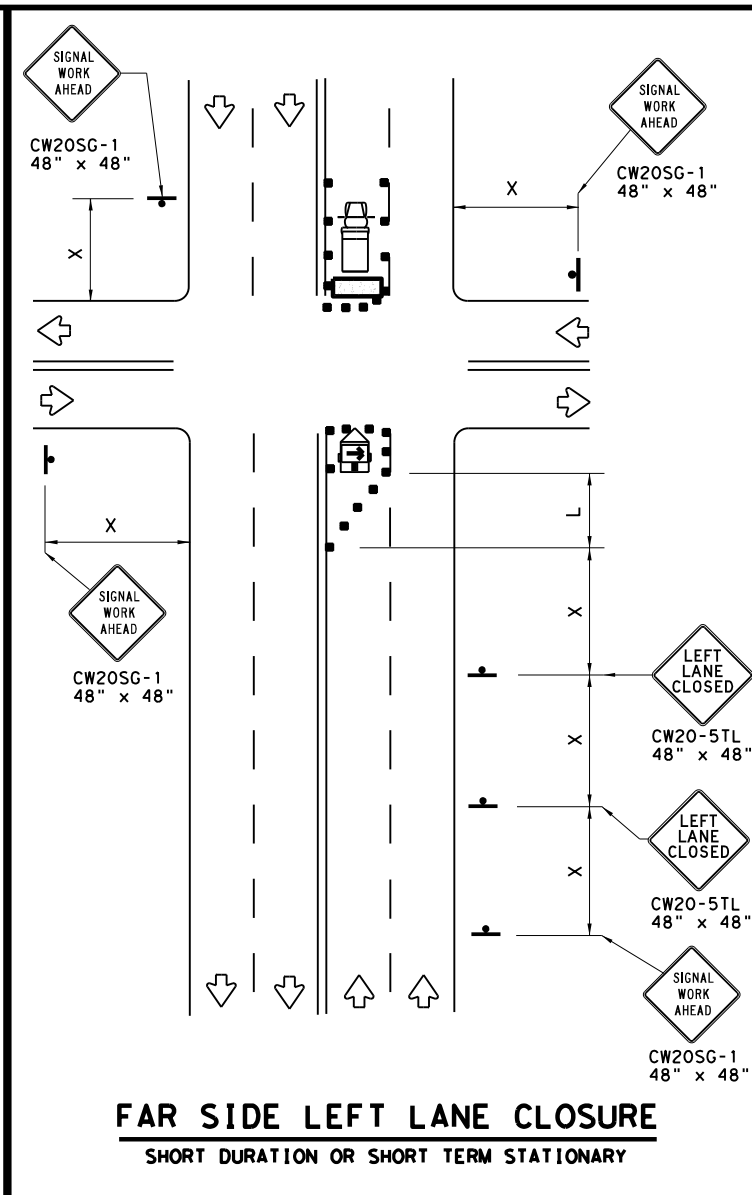
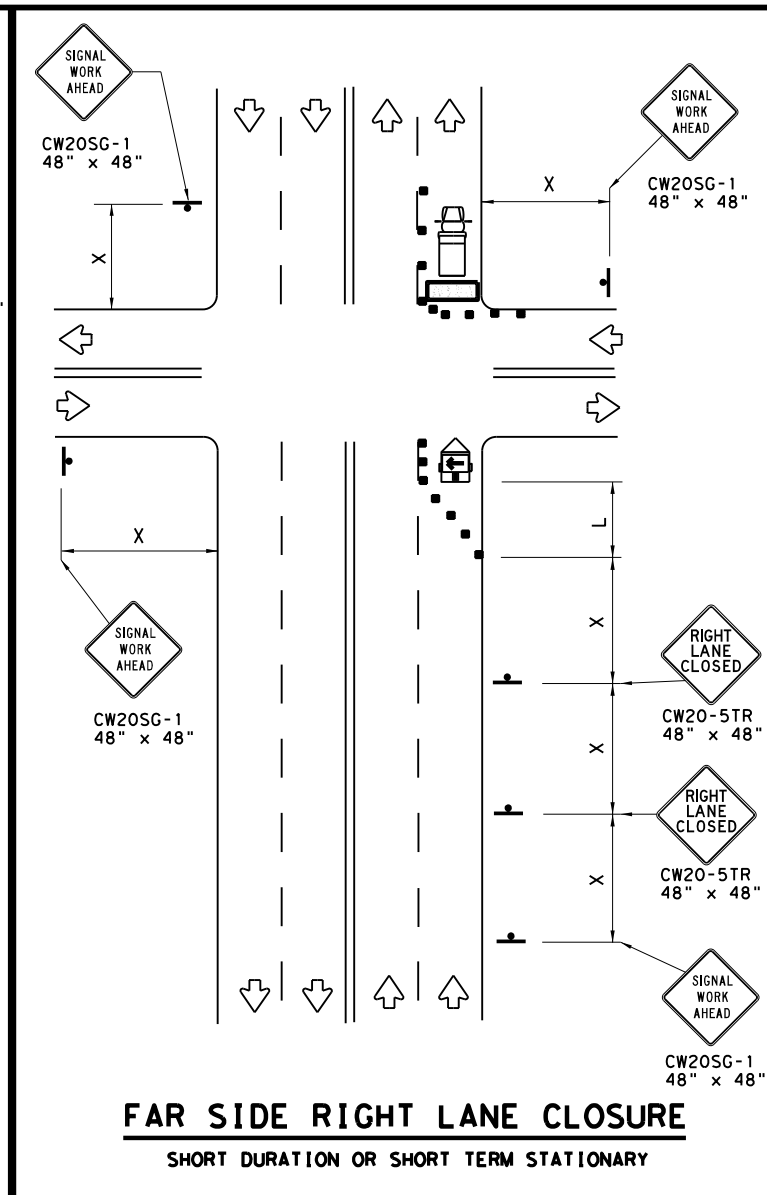
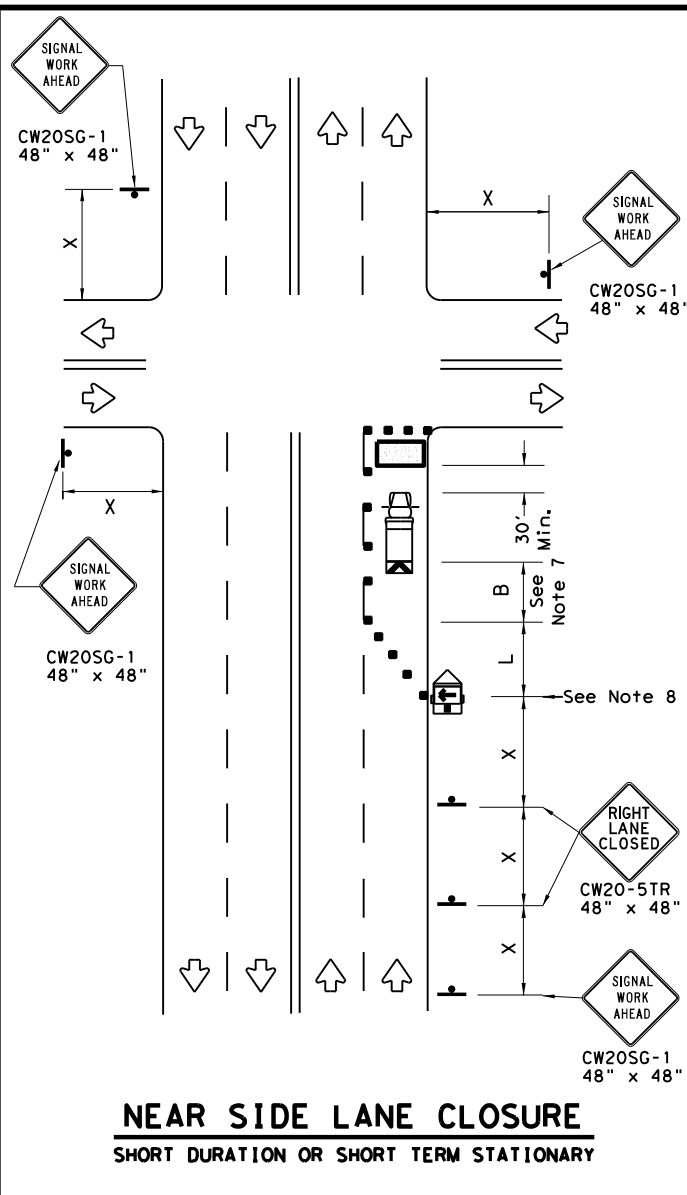

LEGEND			
	Type 3 Barricade		Channelizing Devices
	Heavy Work Vehicle		Truck Mounted Attenuator (TMA)
	Trailer Mounted Flashing Arrow Board		Portable Changeable Message Sign (PCMS)
	Sign		Traffic Flow
	Flag		Flagger

Posted Speed *	Formula	Minimum Desirable Taper Lengths **			Suggested Maximum Spacing of Channelizing Devices		Minimum Sign Spacing "X" Distance	Suggested Longitudinal Buffer Space "B"
		10' Offset	11' Offset	12' Offset	On a Taper	On a Tangent		
30	$L = \frac{WS^2}{60}$	150'	165'	180'	30'	60'	120'	90'
35		205'	225'	245'	35'	70'	160'	120'
40		265'	295'	320'	40'	80'	240'	155'
45	L = WS	450'	495'	540'	45'	90'	320'	195'
50		500'	550'	600'	50'	100'	400'	240'
55		550'	605'	660'	55'	110'	500'	295'
60		600'	660'	720'	60'	120'	600'	350'
65		650'	715'	780'	65'	130'	700'	410'
70		700'	770'	840'	70'	140'	800'	475'
75		750'	825'	900'	75'	150'	900'	540'

\* Conventional Roads Only  
 \*\* Taper lengths have been rounded off.  
 L=Length of Taper (FT) W=Width of Offset (FT) S=Posted Speed (MPH)

**WORKERS IN BUCKET TRUCKS SHALL NOT WORK ABOVE OPEN LANES OF TRAFFIC.**

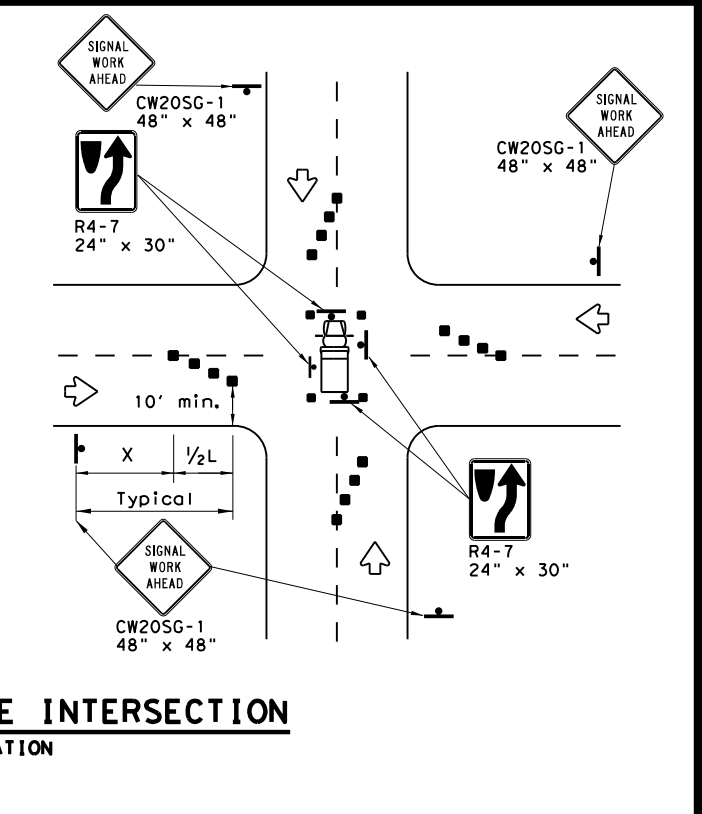
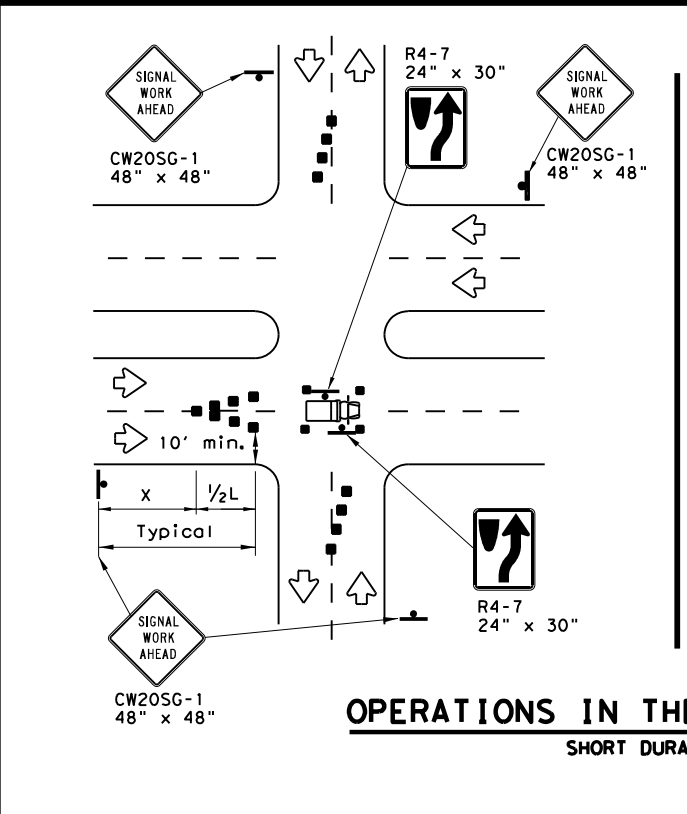

**GENERAL NOTES**

- The minimum size channelizing device is the 28" cone. 42" Two-piece cones, drums, vertical panels or barricades will be required when the device must be left unattended at night.
- Obstructions or hazards at the work area shall be clearly marked and delineated at all times.
- Flaggers and Flagger Symbol (CW20-7) signs may be required according to field conditions.
- Vehicles parked in roadway shall be equipped with at least two high intensity rotating, flashing, oscillating or strobe type lights.
- High level warning devices (flag trees) may be used at corners of the vehicle.
- When work operations are performed on existing signals, the signals may be placed in flashing red mode when approved by the engineer. If existing signals do not have power, All-Way Stop (R1-1 and R1-3P) signs may be implemented when approved by the engineer.
- For Short-Term Stationary work the buffer space "B" from the above table should be used if field conditions permit. For Short Duration (less than 1 hour) any buffer space provided will enhance the safety of the setup.
- The arrow board at this location may be omitted for Short Duration work if the work vehicle has an arrow board in operation. As an option, the arrow board may be placed at the end of the taper in the closed lane if space is not available at the beginning of the taper.
- Signs and devices for the NEAR SIDE LANE CLOSURE may be altered for a left lane closure by using a LEFT LANE CLOSED (CW20-5TL) and adding channelizing devices on the centerline to protect the work space from opposing traffic.



**TRAFFIC SIGNAL WORK TYPICAL DETAILS**

**WZ(BTS-1)-13**

FILE: wzbts-13.dgn	DN: TxDOT	CR: TxDOT	DW: TxDOT	CK: TxDOT
© TxDOT April 1992	CONT	SECT	JOB	HIGHWAY
REVISIONS	091628	071	PR	25A
2-98 10-99 7-13	DIST	COUNTY	SHEET NO.	
4-98 3-03	CRP	SAN PATRICIO	39	

No warranty of any kind is made by TxDOT for any purpose whatsoever. TxDOT assumes no responsibility for the conversion of this standard to metric units. The use of this standard is governed by the "Texas Engineering Practice Act". No warranty of any kind is made by TxDOT for any purpose whatsoever. TxDOT assumes no responsibility for the conversion of this standard to metric units.

DATE: 1/13/2023 5:17:49 PM  
 FILE: \\txdot.projectwiseonline.com:TXDOT4\Documents\16 - CRP\Design Projects\16091011\16091011.dwg

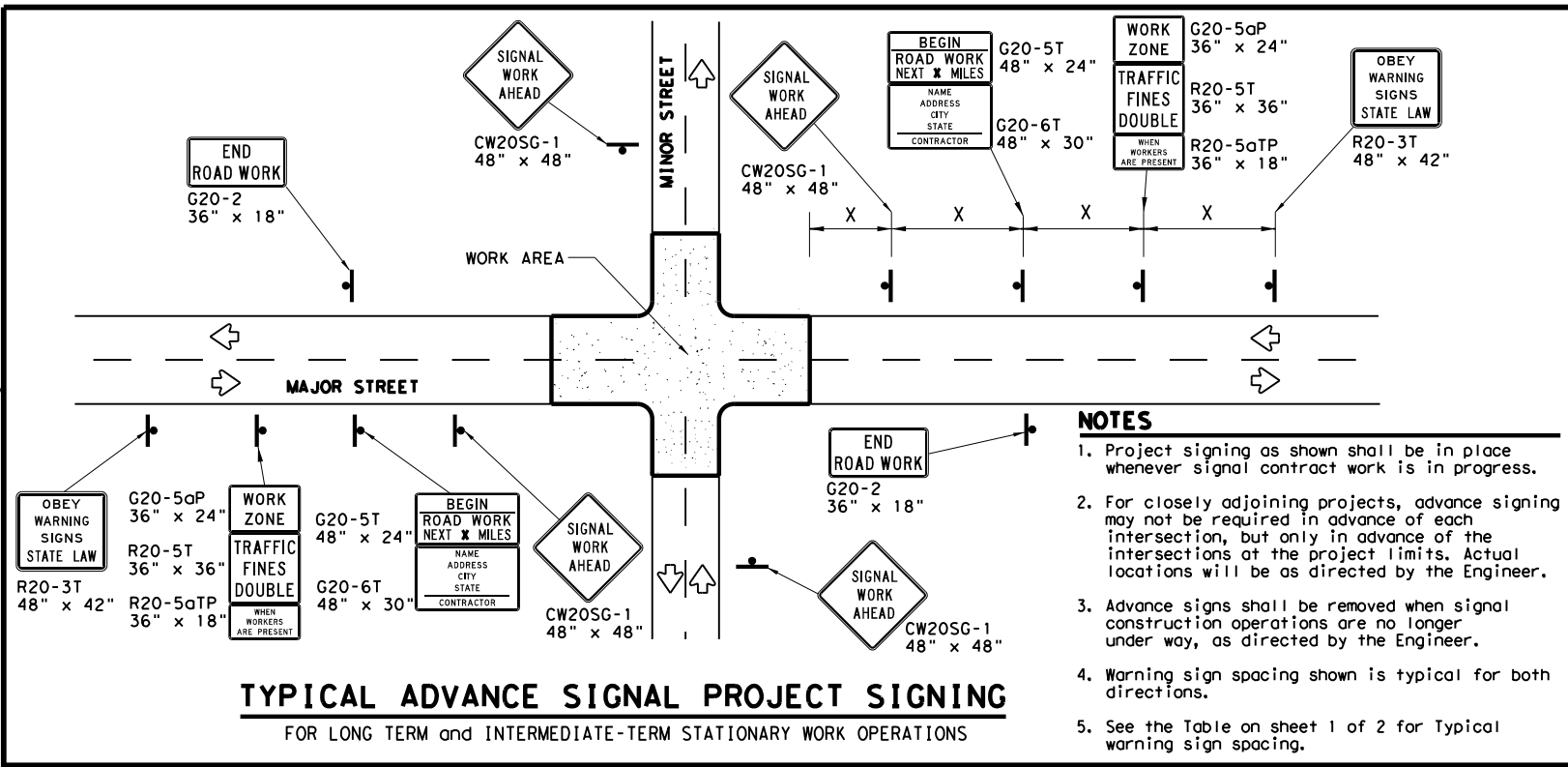

- NOTES**
1. Project signing as shown shall be in place whenever signal contract work is in progress.
  2. For closely adjoining projects, advance signing may not be required in advance of each intersection, but only in advance of the intersections at the project limits. Actual locations will be as directed by the Engineer.
  3. Advance signs shall be removed when signal construction operations are no longer under way, as directed by the Engineer.
  4. Warning sign spacing shown is typical for both directions.
  5. See the Table on sheet 1 of 2 for Typical warning sign spacing.

**GENERAL NOTES FOR WORK ZONE SIGNS**

1. Signs shall be installed and maintained in a straight and plumb condition.
2. Wooden sign posts shall be painted white.
3. Barricades shall NOT be used as sign supports.
4. Nails shall NOT be used to attach signs to any support.
5. All signs shall be installed in accordance with the plans or as directed by the Engineer.
6. The Contractor shall furnish the sign design shown in the plans or in the "Standard Highway Sign Designs for Texas" (SHSD).
7. The Contractor shall furnish sign supports and substrates listed in the "Compliant Work Zone Traffic Control Device List" (CWZTCD), installed as per the manufacturer's recommendations.
8. Temporary signs that have damaged or cracked substrates and/or damaged or marred reflective sheeting shall be replaced as directed by the Engineer.
9. Identification markings may be shown only on the back of the sign substrate. The maximum height of letters and/or company logos used for identification shall be 1".
10. Damaged wood posts shall be replaced. Splicing wood posts will not be allowed.

**DURATION OF WORK**

1. Work zone durations are defined in Part 6, Section 60.02 of the Texas Manual on Uniform Traffic Control Devices (TMUTCD).

**SIGN MOUNTING HEIGHT**

1. Sign height of Long-term/Intermediate-term warning signs shall be as shown on Figure 6F-1 of the TMUTCD.
2. Sign height of Short-term/Short Duration warning signs shall be as shown on Figure 6F-2 of the TMUTCD.
3. Regulatory signs shall be mounted at least 7 feet, but not more than 9 feet, above the paved surface regardless of work duration.

**REMOVING OR COVERING**

1. When sign messages may be confusing or do not apply, the signs shall be removed or completely covered, unless otherwise approved by the Engineer.
2. When signs are covered, the material used shall be opaque, such as heavy mil black plastic, or other materials which will cover the entire sign face and maintain their opaque properties under automobile headlights at night without damaging the sign sheeting. Burlap, or heavy materials such as plywood or aluminum shall not be used to cover signs.
3. Duct tape or other adhesive material shall NOT be affixed to a sign face.
4. Signs and anchor stubs shall be removed and holes back filled upon completion of the work.

**REFLECTIVE SHEETING**

1. All signs shall be retroreflective and constructed of sheeting meeting the requirements of the DMS and color usage table shown on this sheet.

**SIGN SUPPORT WEIGHTS**

1. Weights used to keep signs from turning over should be sandbags filled with dry, cohesionless material.
2. The sandbags will be tied shut to keep the sand from spilling and to maintain a constant weight.
3. Rock, concrete, iron, steel or other solid objects will not be permitted for use as sign support weights.
4. Sandbags should weigh a minimum of 35 lbs and a maximum of 50 lbs.
5. Sandbags shall be made of a durable material that tears upon vehicular impact. Rubber, such as tire inner tubes, shall not be used.
6. Rubber ballasts designed for channelizing devices should not be used for ballast on portable sign supports. Sign supports designed and manufactured with rubber bases may be used when shown on the CWZTCD list.
7. Sandbags shall only be placed along or laid over the base supports of the traffic control device and shall not be suspended above ground level or hung with rope, wire, chains or other fasteners. Sandbags shall be placed along the length of the skids to weigh down the sign support.
8. Sandbags shall NOT be placed under the skid and shall not be used to level sign supports placed on slopes.

**LEGEND**

	Sign
	Channelizing Devices
	Type 3 Barricade

**DEPARTMENTAL MATERIAL SPECIFICATIONS**

SIGN FACE MATERIALS	DMS-8300
FLEXIBLE ROLL-UP REFLECTIVE SIGNS	DMS-8310

COLOR	USAGE	SHEETING MATERIAL
ORANGE	BACKGROUND	TYPE B <sub>FL</sub> OR TYPE C <sub>FL</sub> SHEETING
WHITE	BACKGROUND	TYPE A SHEETING
BLACK	LEGEND & BORDERS	ACRYLIC NON-REFLECTIVE SHEETING

Only pre-qualified products shall be used. A copy of the "Compliant Work Zone Traffic Control Devices List" (CWZTCD) describes pre-qualified products and their sources and may be found at the following web address:  
[http://www.txdot.gov/txdot\\_library/publications/construction.htm](http://www.txdot.gov/txdot_library/publications/construction.htm)

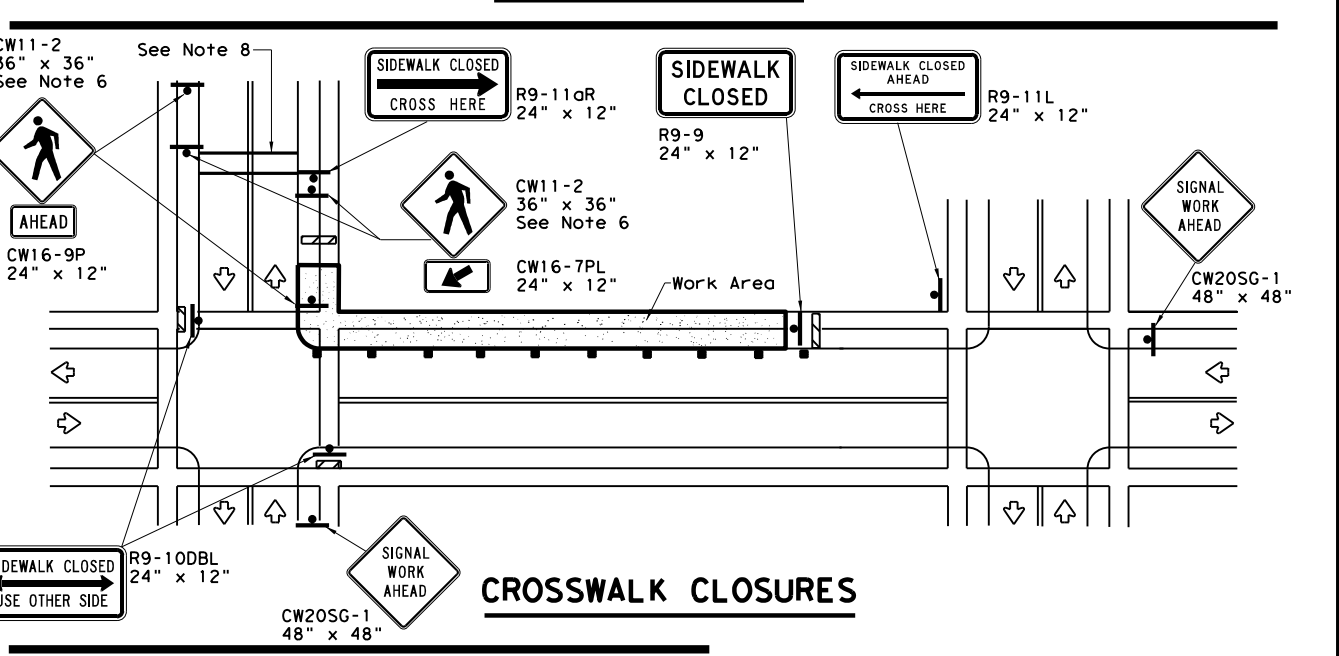
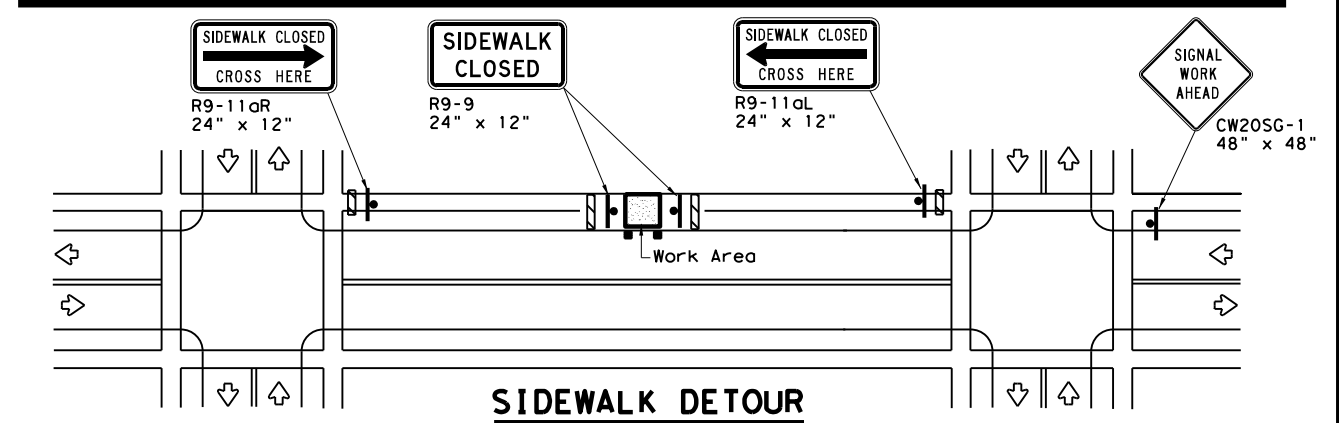
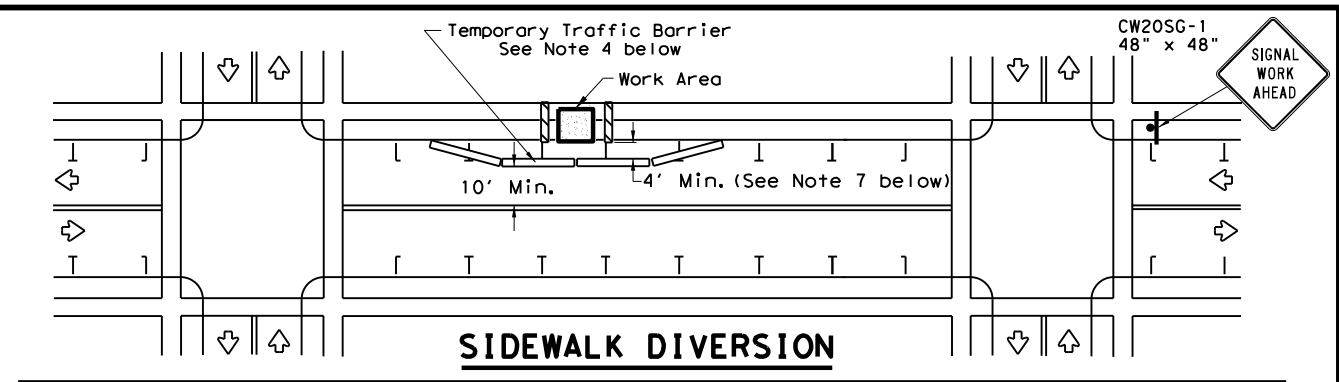

**PEDESTRIAN CONTROL**

1. Holes, trenches or other hazards shall be adequately protected by covering, delineating or surrounding the hazard with orange plastic pedestrian fencing or longitudinal channelizing devices, or as directed by the Engineer.
2. "CROSSWALK CLOSURES" as detailed above will require the Engineer's approval prior to installation.
3. R9 series signs shown may be placed on supports detailed on the BC standards or CWZTCD list, or when fabricated from approved lightweight plastic substrates, they may be mounted on top of a plastic drum at or near the location shown.
4. For speeds less than 45 mph longitudinal channelizing devices may be used instead of traffic barriers when approved by the Engineer. Attenuation of blunt ends and installation of water filled devices shall be as per BC(9) and manufacturer's recommendations.
5. Location of devices are for general guidance. Actual device spacing and location must be field adjusted to meet actual conditions.
6. Where pedestrians with visual disabilities normally use the closed sidewalk Detectable Pedestrian Barricades should be used instead of the Type 3 Barricades shown.
7. The width of existing sidewalk should be maintained if practical.
8. Pavement markings for mid-block crosswalks shall be paid for under the appropriate bid items.
9. When crosswalks or other pedestrian facilities are closed or relocated, temporary facilities shall be detectable and shall include accessibility features consistent with the features present in the existing pedestrian facility.

SHEET 2 OF 2

Traffic Operations Division Standard

TRAFFIC SIGNAL WORK  
 BARRICADES AND SIGNS

WZ (BTS-2) - 13

FILE: wzbts-13.dgn	DN: TxDOT	CR: TxDOT	DW: TxDOT	CK: TxDOT
© TxDOT April 1992	CONT	SECT	JOB	HIGHWAY
REVISIONS	0916 28	071	PR 25A	
2-98 10-99 7-13	DIST	COUNTY	SHEET NO.	
4-98 3-03	CRP	SAN PATRICIO	40	



DISCLAIMER: The use of this standard is governed by the "Texas Engineering Practice Act". No warranty of any kind is made by TxDOT for any purpose whatsoever. TxDOT assumes no responsibility for the conversion of units or the accuracy of the information contained herein. For more information, visit [www.txdot.gov](http://www.txdot.gov).

DATE: 1/13/2023 5:18:09 PM  
 FILE: \\txdot\project\wiseonline.com\txdot\4\Documents\16 - CRP\Design Projects\16-001\16-001.dgn

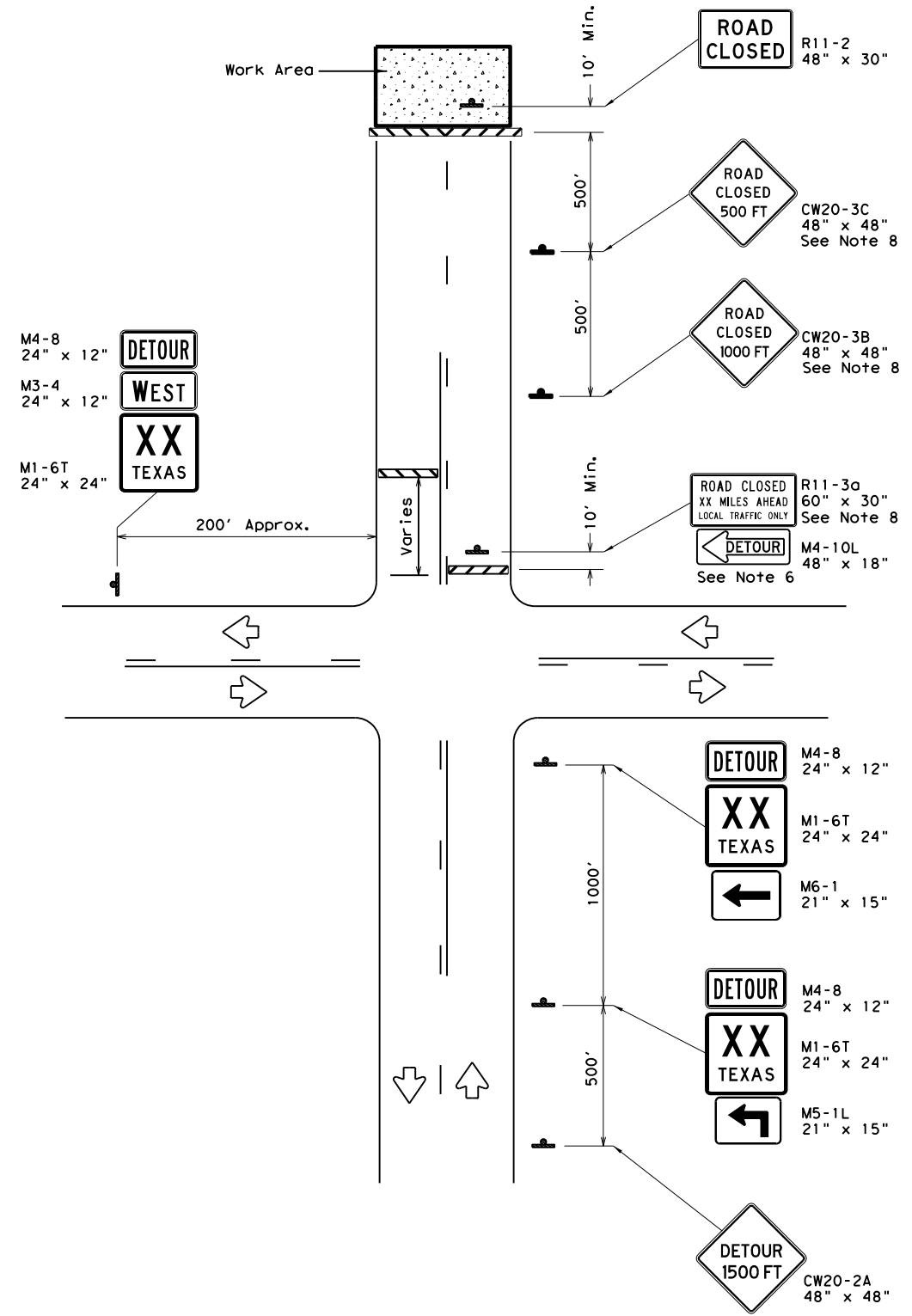

**ROAD CLOSURE BEYOND THE INTERSECTION**  
 Signing for a Numbered Route with an Off-Site Detour

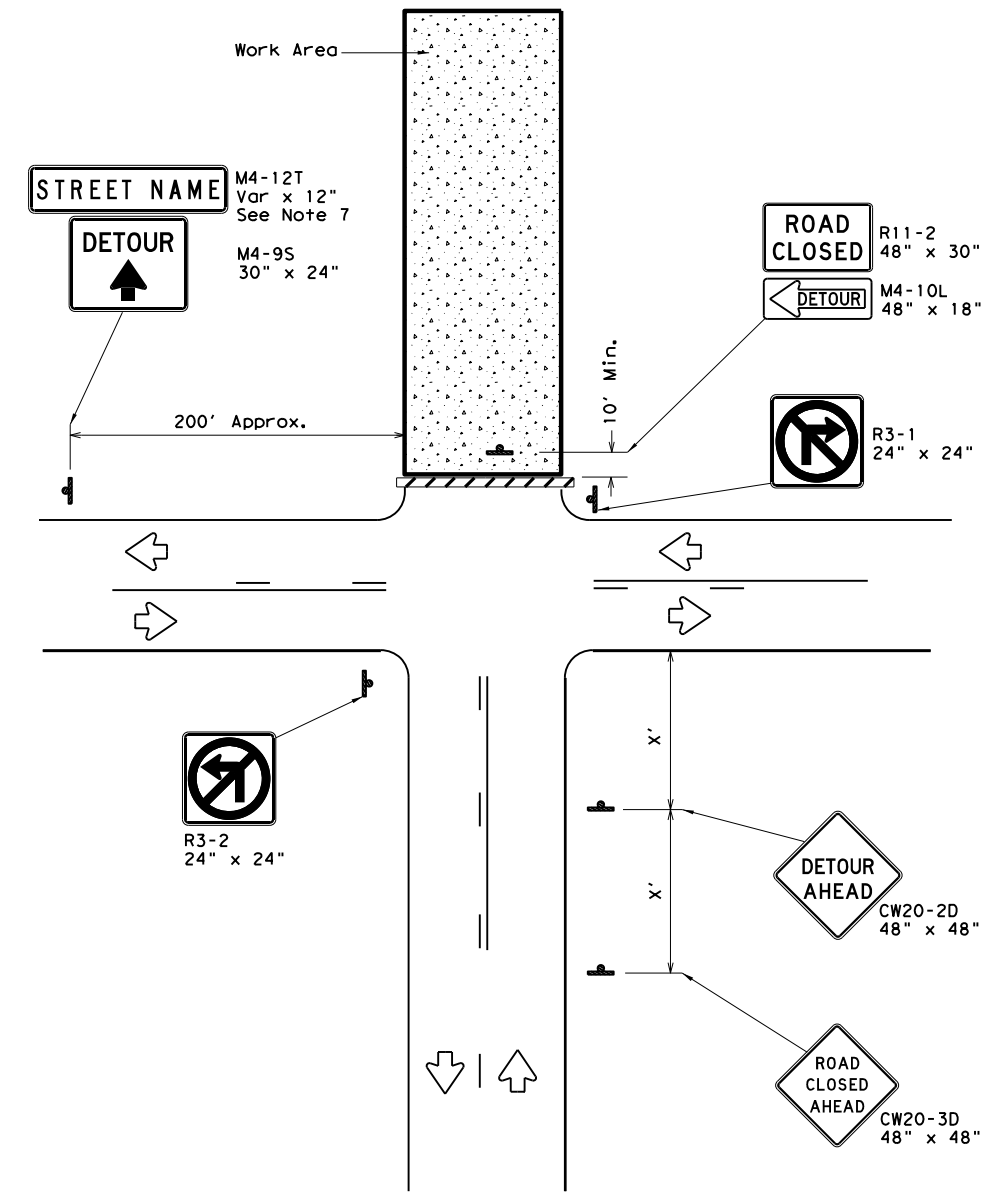

**ROAD CLOSURE AT THE INTERSECTION**  
 Signing for an Un-numbered Route with an Off-Site Detour

LEGEND	
	Type 3 Barricade
	Sign

Posted Speed *	Minimum Sign Spacing "x" Distance
30	120'
35	160'
40	240'
45	320'
50	400'
55	500'
60	600'
65	700'
70	800'
75	900'

\* Conventional Roads Only

**GENERAL NOTES**

- This sheet is intended to provide details for temporary work zone road closures. For permanent road closure details see the D&OM standards.
- Barricades used shall meet the requirements shown on Barricade and Construction Standard BC(10) and listed on the Compliant Work Zone Traffic Control Devices list (CWZTCD).
- Stockpiled materials shall not be placed on the traffic side of barricades.
- Barricades at the road closure should extend from pavement edge to pavement edge.
- Detour signing shown is intended to illustrate the type of signing that is appropriate for numbered routes or un-numbered routes as labeled. It does not indicate the full extent of detour signing required. Detour routes should be signed as shown elsewhere in the plans.
- If the road is open for a significant distance beyond the intersection or there are significant origin/destination points beyond the intersection, the signs and barricades at this location should be located at the edge of the traveled way.
- The Street Name (M4-12T) sign is to be placed above the DETOUR (M4-9S) sign.
- For urban areas where there is a shorter distance between the intersection and the actual closure location, the ROAD CLOSED XX MILES AHEAD (R11-3a) sign may be replaced with a ROAD CLOSED TO THRU TRAFFIC (R11-4) sign. If adequate space does not exist between the intersection and the closure a single ROAD CLOSED AHEAD (CW20-3D) sign spaced as per the table above may replace the ROAD CLOSED 1000 FT (CW20-3B) and ROAD CLOSED 500 FT (CW20-3C) signs.
- Signs and barricades shown shall be subsidiary to Item 502. Locations where these details will be required shall be as shown elsewhere in the plans.

		Traffic Operations Division Standard	
<b>WORK ZONE ROAD CLOSURE DETAILS</b>			
<b>WZ (RCD) - 13</b>			
FILE: wzrcd-13.dgn	DN: TxDOT	CK: TxDOT	DW: TxDOT
© TxDOT August 1995	CONT	SECT	JOB
REVISIONS	0916	28	071
1-97 4-98 7-13	DIST	COUNTY	SHEET NO.
2-98 3-03	CRP	SAN PATRICIO	42

DISCLAIMER: The use of this standard is governed by the "Texas Engineering Practice Act". No warranty of any kind is made by TxDOT for any purpose whatsoever. TxDOT assumes no responsibility for the conversion of units or the accuracy of the information contained herein. The user of this standard is advised to verify the accuracy of the information contained herein for their specific application. DATE: 1/13/2023 5:18:18 PM FILE: pw://txdot.projectwiseonline.com:txdot4/Documents/16 - CRP/Design Projects/091628/071/091628-071-25A.dgn

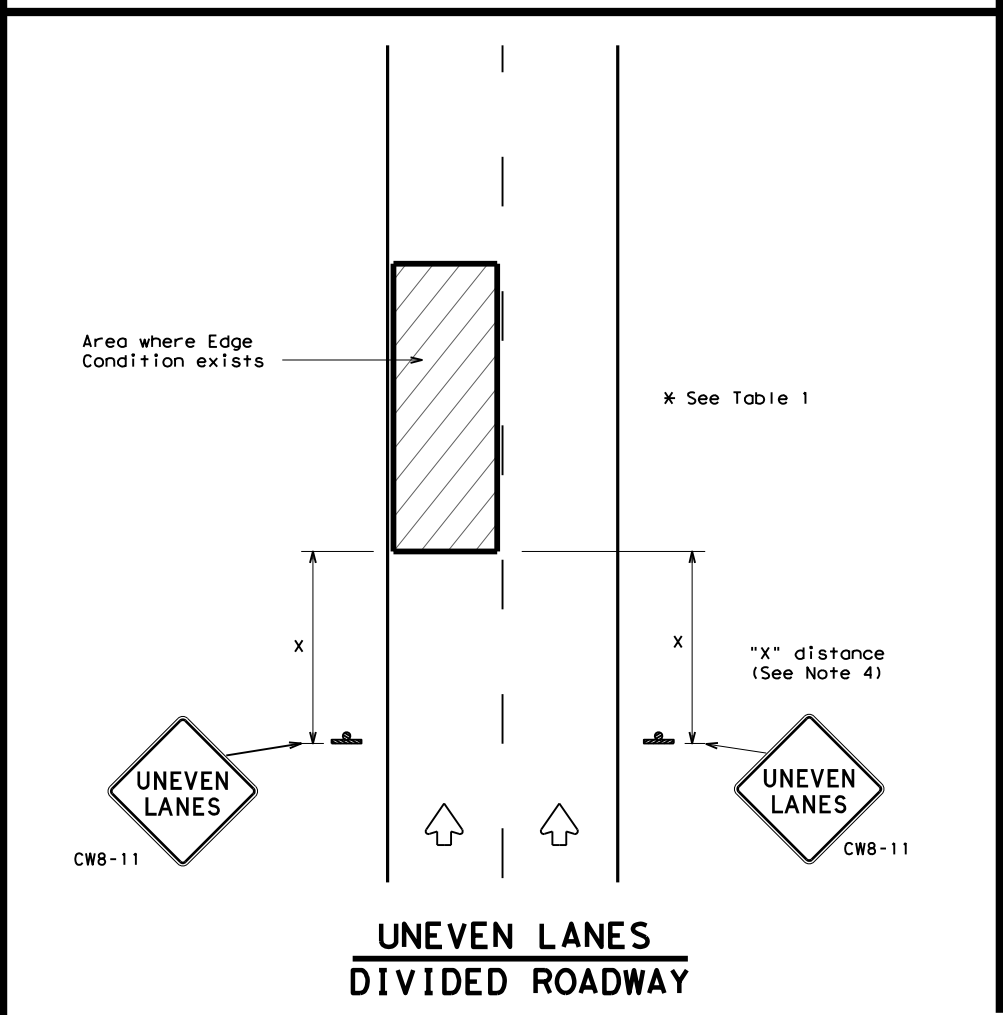
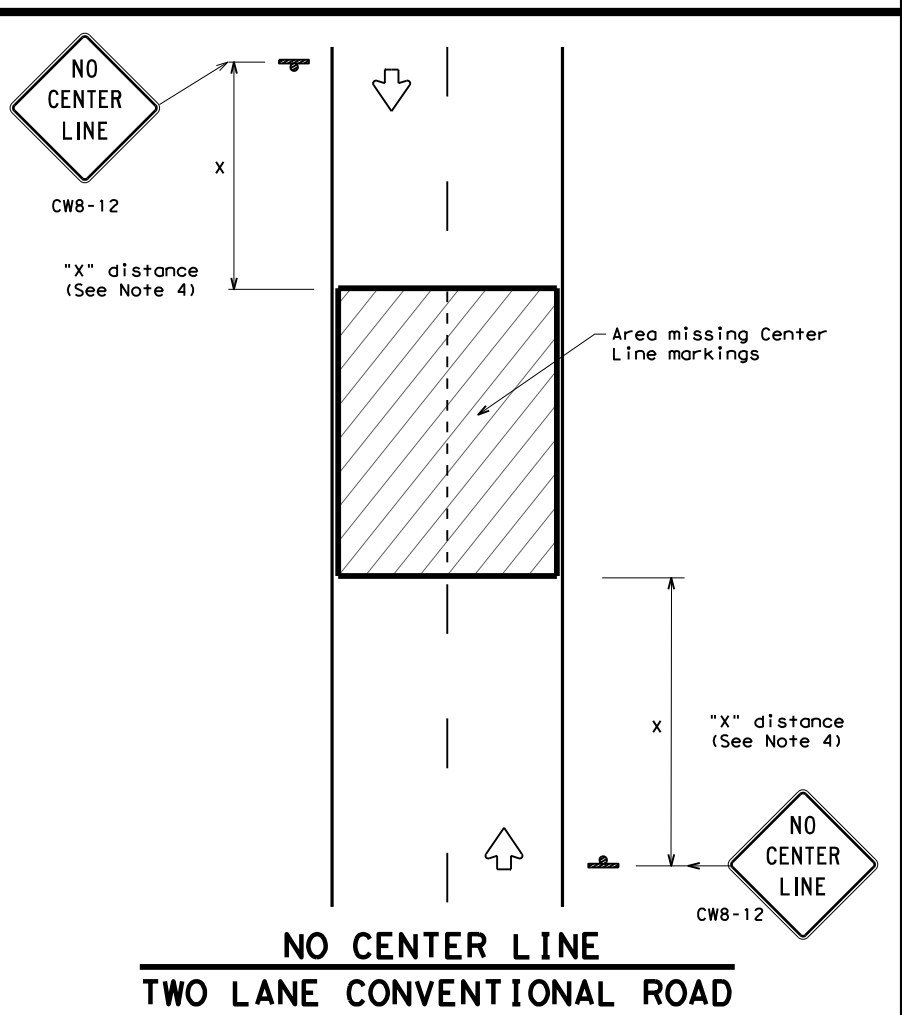
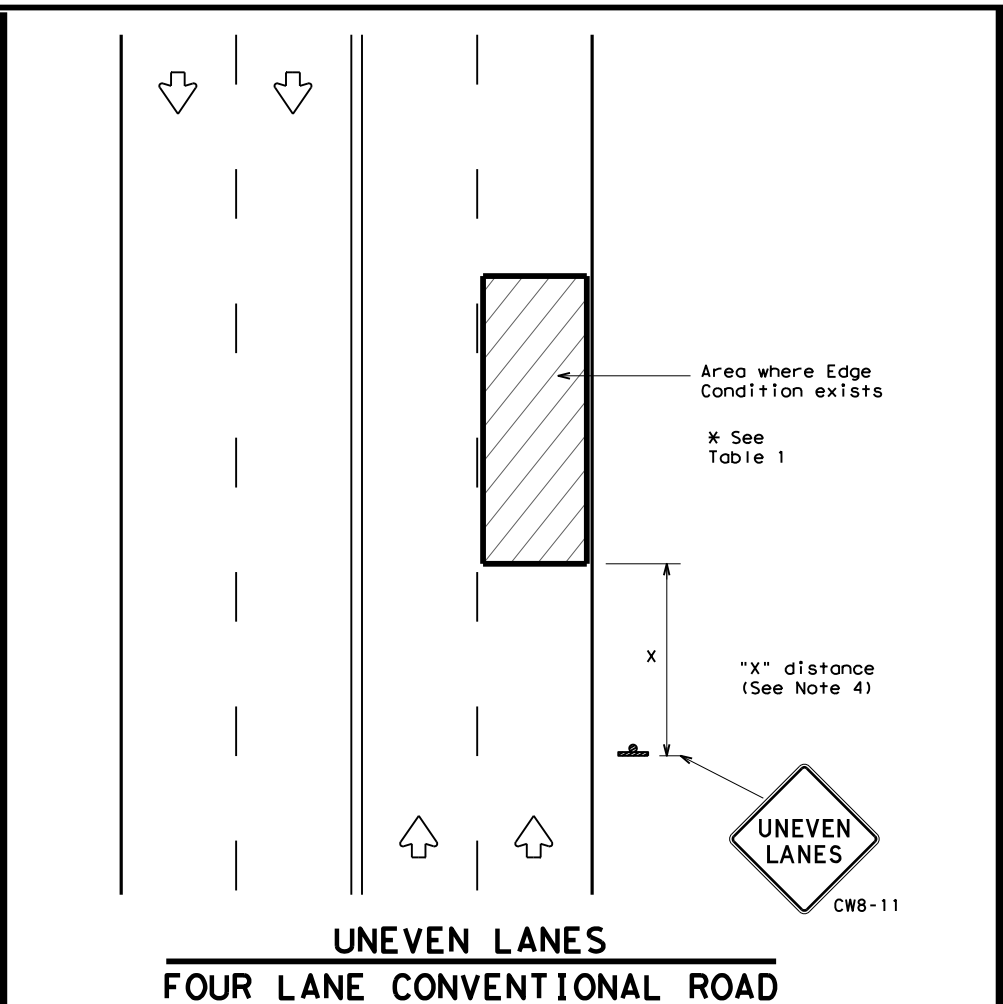
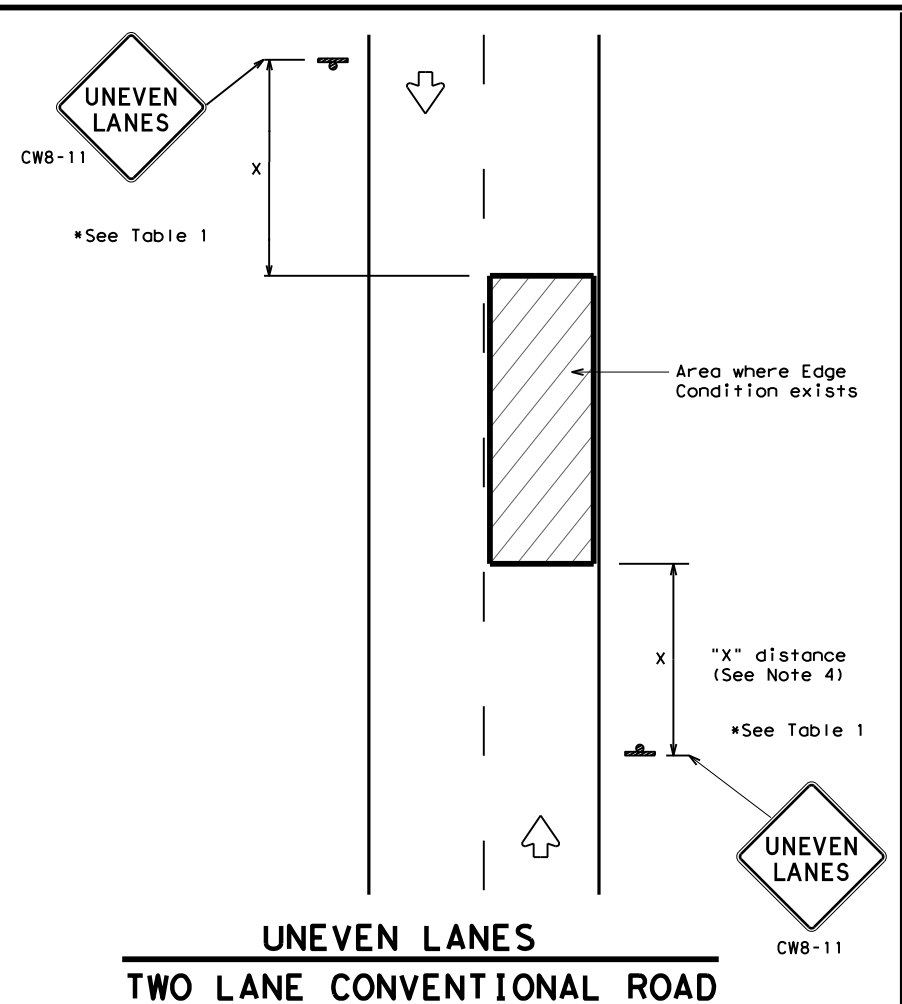

DEPARTMENTAL MATERIAL SPECIFICATIONS	
PERMANENT PREFABRICATED PAVEMENT MARKINGS	DMS-8240
TEMPORARY (REMOVABLE) PREFABRICATED PAVEMENT MARKINGS	DMS-8241
SIGN FACE MATERIALS	DMS-8300

COLOR	USAGE	SHEETING MATERIAL
ORANGE	BACKGROUND	TYPE B <sub>FL</sub> OR TYPE C <sub>FL</sub> SHEETING
BLACK	LEGEND & BORDERS	ACRYLIC NON-REFLECTIVE SHEETING

- GENERAL NOTES**
- If spalling or holes occur, ROUGH ROAD (CW8-8) signs should be placed in advance of the condition and be repeated every two miles where the condition persists.
  - UNEVEN LANES (CW8-11) signs shall be installed in advance of the condition and repeated every mile. Signs installed along the uneven lane condition may be supplemented with the NEXT XX MILES (CW7-3aP) plaque or Advisory Speed (CW13-1P) plaque.
  - NO CENTER LINE (CW8-12) signs and temporary pavement markings as per the WZ(STPM) standard shall be installed if yellow centerlines separating two way traffic are obscured or obliterated. Repeat NO CENTER LINE signs every two miles where the center line markings are not in place. The signs and markings shall remain in place until permanent pavement markings are installed.
  - Signs shall be spaced at the distances recommended as per BC standards.
  - Additional signs may be required as directed by the Engineer. Signs shall remain in place until final surface is applied. Signs shall be considered subsidiary to Item 502 "BARRICADES, SIGNS AND TRAFFIC HANDLING."
  - Signs shall be fabricated and mounted on supports as shown on the BC standards and/or listed on the "Compliant Work Zone Traffic Control Devices" list.
  - Short term markings shall not be used to simulate edge lines.
  - All signs shall be constructed in accordance with the details found in the "Standard Highway Sign Designs for Texas," latest edition.

TABLE 1		
Edge Condition	Edge Height (D)	* Warning Devices
①	Less than or equal to: 1/4" (maximum-planing) 1/2" (typical-overlay)	Sign: CW8-11
②	Less than or equal to 3"	Sign: CW8-11
③	Distance "D" may be a maximum of 3" if uneven lanes with edge condition 2 or 3 are open to traffic after work operations cease. Uneven lanes should not be open to traffic when "D" is greater than 3".	

TRAFFIC CONTROL DURING PLANING, OVERLAY AND LEVELING OPERATIONS ARE SHOWN ELSEWHERE IN THE PLANS.

MINIMUM WARNING SIGN SIZE	
Conventional roads	36" x 36"
Freeways/expressways, divided roadways	48" x 48"

Texas Department of Transportation  
Traffic Operations Division Standard

## SIGNING FOR UNEVEN LANES

### WZ(UL) - 13







FILE: WZUL-13.dgn	DN: TxDOT	CR: TxDOT	DW: TxDOT	CK: TxDOT
© TxDOT	APRIL 1992	CONT	SECT	JOB
REVISIONS	091628	071	PR	25A
8-95 2-98 7-13	DIST	COUNTY	SHEET NO.	
1-97 3-03	CRP	SAN PATRICIO	43	



01/13/2023



LEGEND

-  - BASE REPAIR
-  - HOT-MIX OVERLAY
-  - ACCESSIBLE COMPLIANT PARKING
-  - PARKING LOT
-  - RV BACK-IN LOT
-  - RV PULL-THROUGH
-  - DRIVEWAY

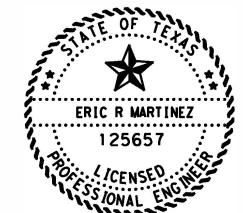

*E. Martinez*

GOOSE ISLAND  
 STATE PARK  
 LAYOUT MAP





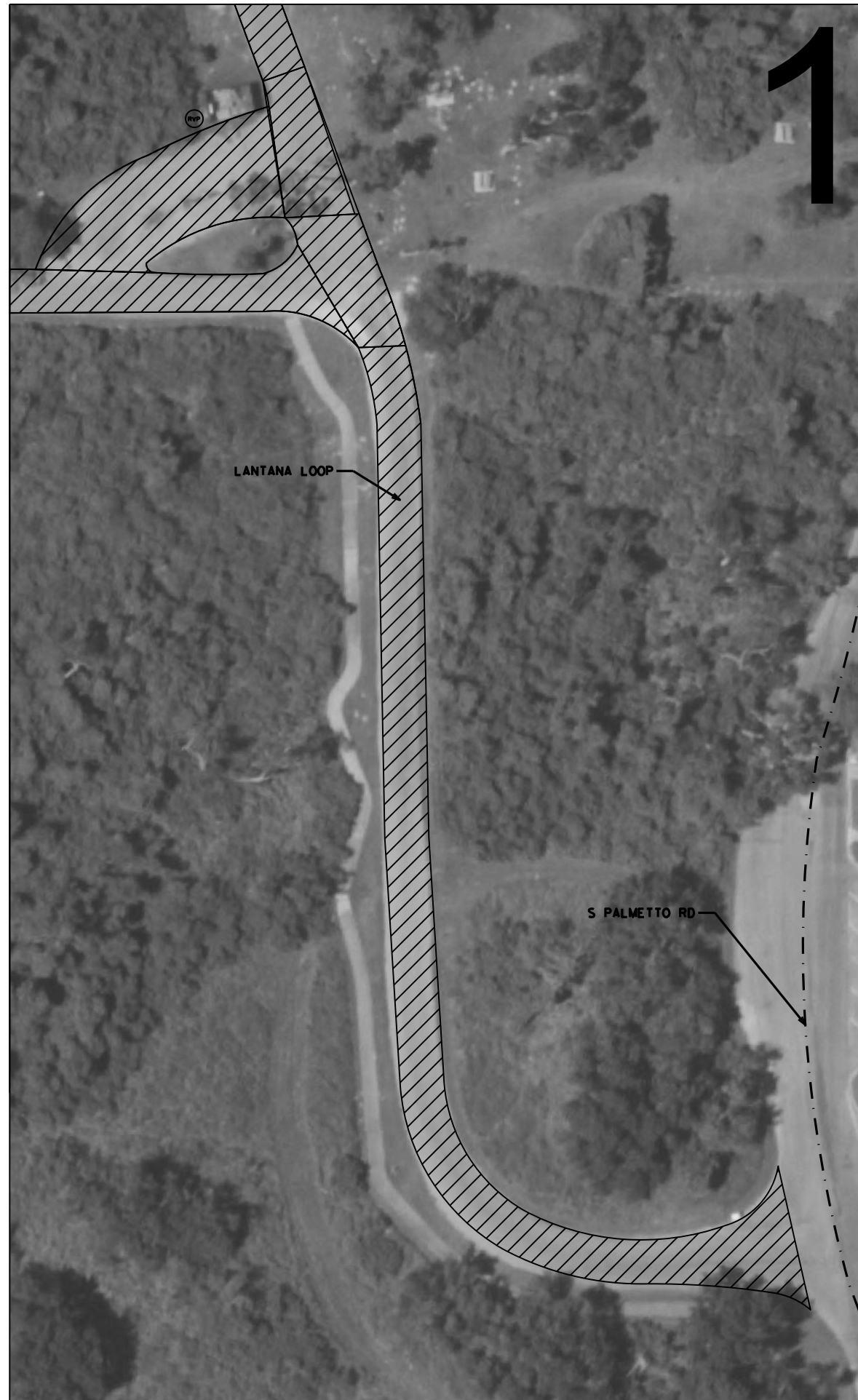

SHEET 1 OF 1

NOT TO SCALE

			
CONT	SECT	JOB	HIGHWAY
0916	28	071	PR 25A
DIST	COUNTY	SHEET NO.	
CRP	SAN PATRICIO	44	



LEGEND

-  - BASE REPAIR
-  - HOT-MIX OVERLAY
-  - ACCESSIBLE COMPLIANT PARKING
-  - PARKING LOT
-  - RV BACK-IN LOT
-  - RV PULL-THROUGH
-  - DRIVEWAY

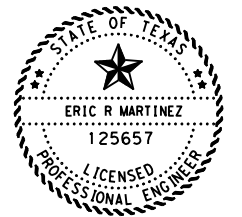

*E. Martinez*

01/13/2023

**GOOSE ISLAND  
 STATE PARK  
 ROADWAY DETAILS**

SHEET 1 OF 8



CONT	SECT	JOB	HIGHWAY
0916	28	071	PR 25A
DIST	COUNTY	SHEET NO.	
CRP	SAN PATRICIO	45	

NOT TO SCALE

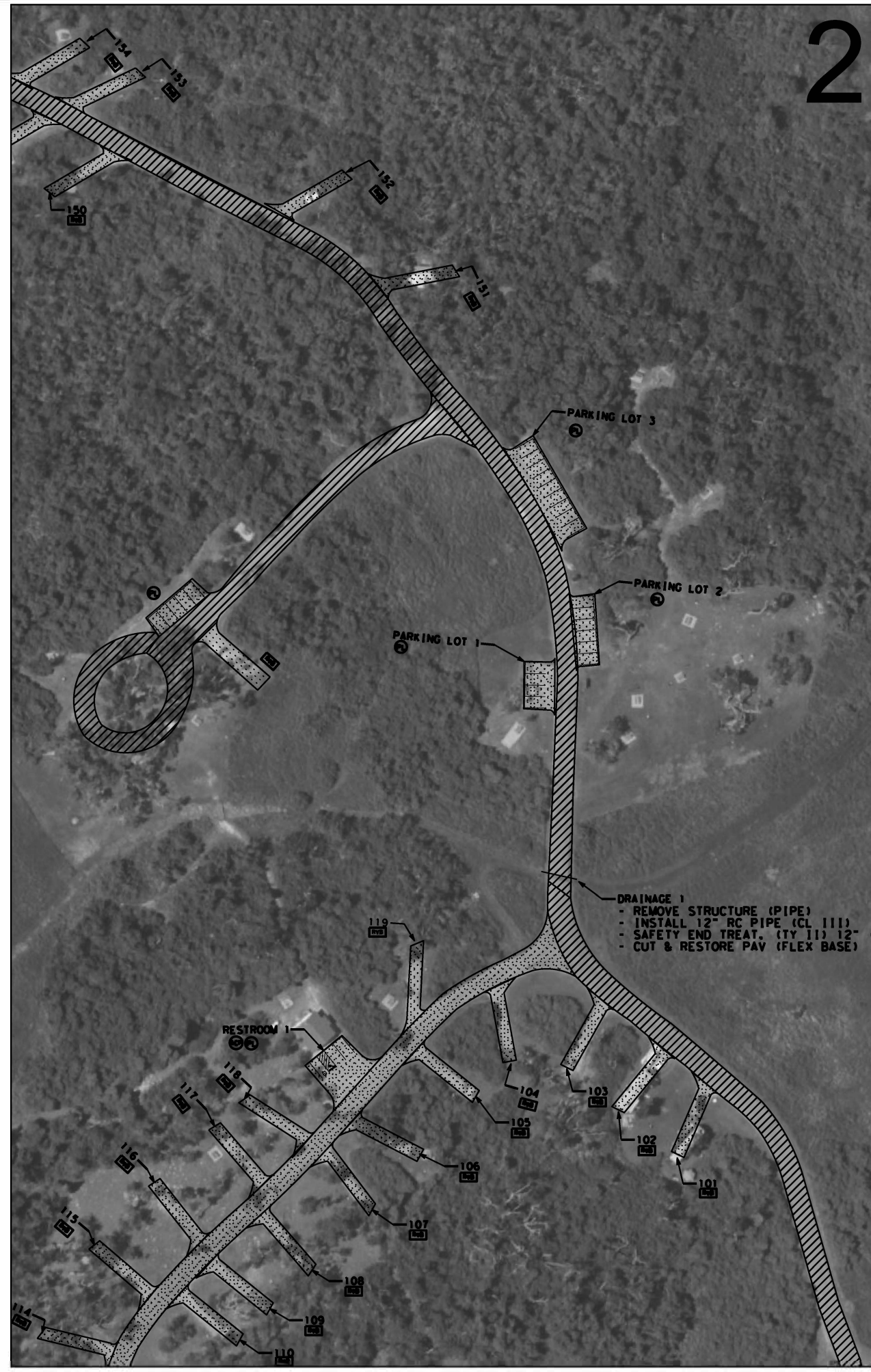

2

01/13/2023

- LEGEND
- BASE REPAIR
  - HOT-MIX OVERLAY
  - ACCESSIBLE COMPLIANT PARKING
  - PARKING LOT
  - RV BACK-IN LOT
  - RV PULL-THROUGH
  - DRIVEWAY

DRAINAGE 1  
 - REMOVE STRUCTURE (PIPE)  
 - INSTALL 12" RC PIPE (CL 111)  
 - SAFETY END TREAT. (TY 11) 12" (RCP) (3:1) (C)  
 - CUT & RESTORE PAV (FLEX BASE)



*E. Martinez*

GOOSE ISLAND  
 STATE PARK  
 ROADWAY DETAILS

SHEET 2 OF 8



NOT TO SCALE

CONT	SECT	JOB	HIGHWAY
0916	28	071	PR 25A
DIST	COUNTY	SHEET NO.	
CRP	SAN PATRICIO	46	



- LEGEND**
- BASE REPAIR
  - HOT-MIX OVERLAY
  - ACCESSIBLE COMPLIANT PARKING
  - PARKING LOT
  - RV BACK-IN LOT
  - RV PULL-THROUGH
  - DRIVEWAY

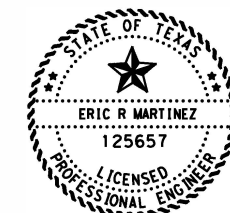

*E. Martinez*

**GOOSE ISLAND  
 STATE PARK  
 ROADWAY DETAILS**

NOT TO SCALE

SHEET 3 OF 8

CONT	SECT	JOB	HIGHWAY
0916	28	071	PR 25A
DIST	COUNTY	SHEET NO.	
CRP	SAN PATRICIO	47	

01/13/2023

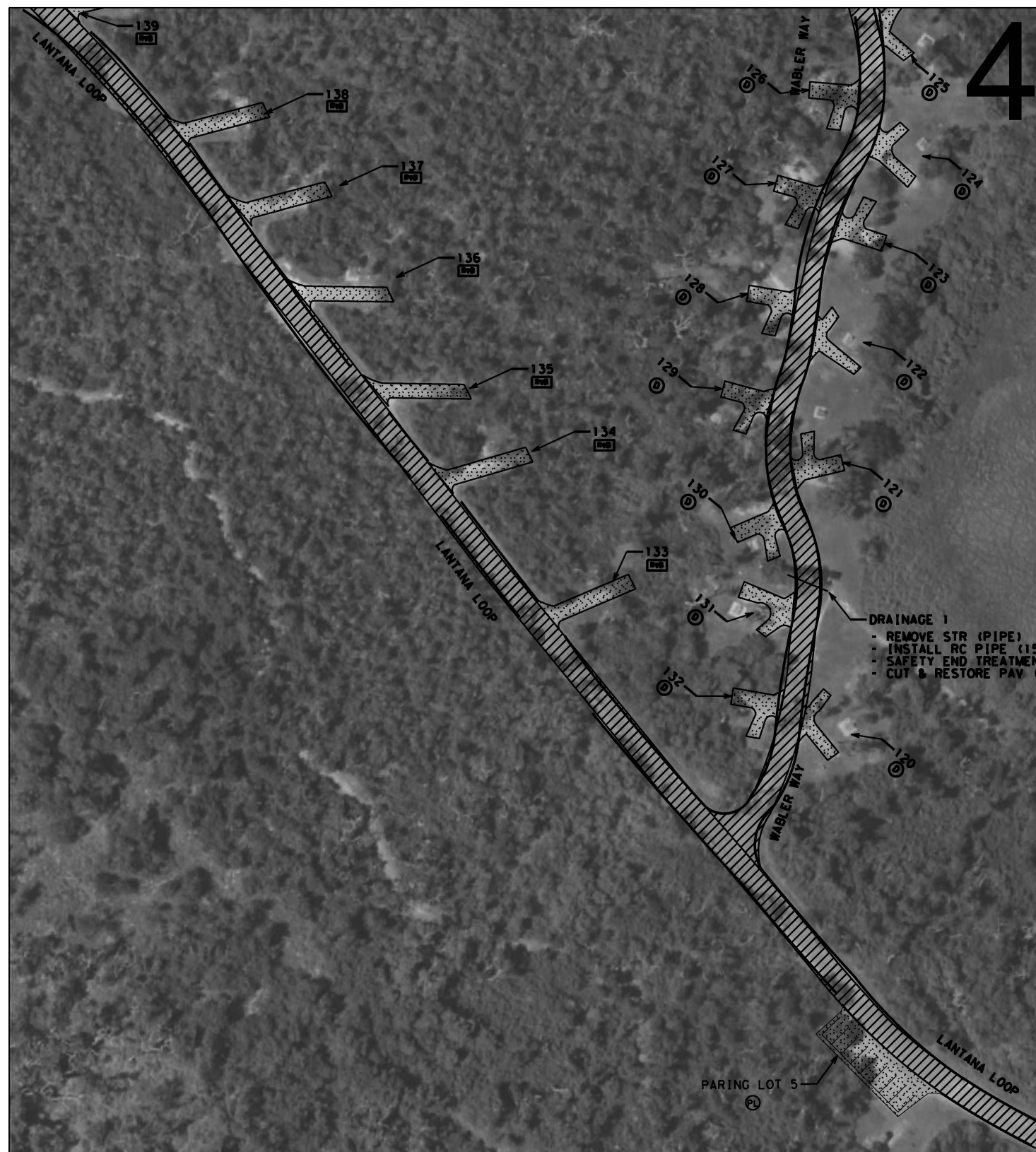

LEGEND

- BASE REPAIR
- HOT-MIX OVERLAY
- ACCESSIBLE COMPLIANT PARKING
- PARKING LOT
- RV BACK-IN LOT
- RV PULL-THROUGH
- DRIVEWAY

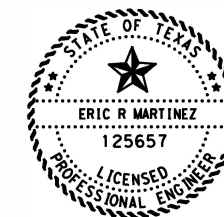

*E. Martinez*

GOOSE ISLAND  
 STATE PARK  
 ROADWAY DETAILS

SHEET 4 OF 8

CONT	SECT	JOB	HIGHWAY
0916	28	071	PR 25A
DIST	COUNTY		SHEET NO.
CRP	SAN PATRICIO		48

NOT TO SCALE

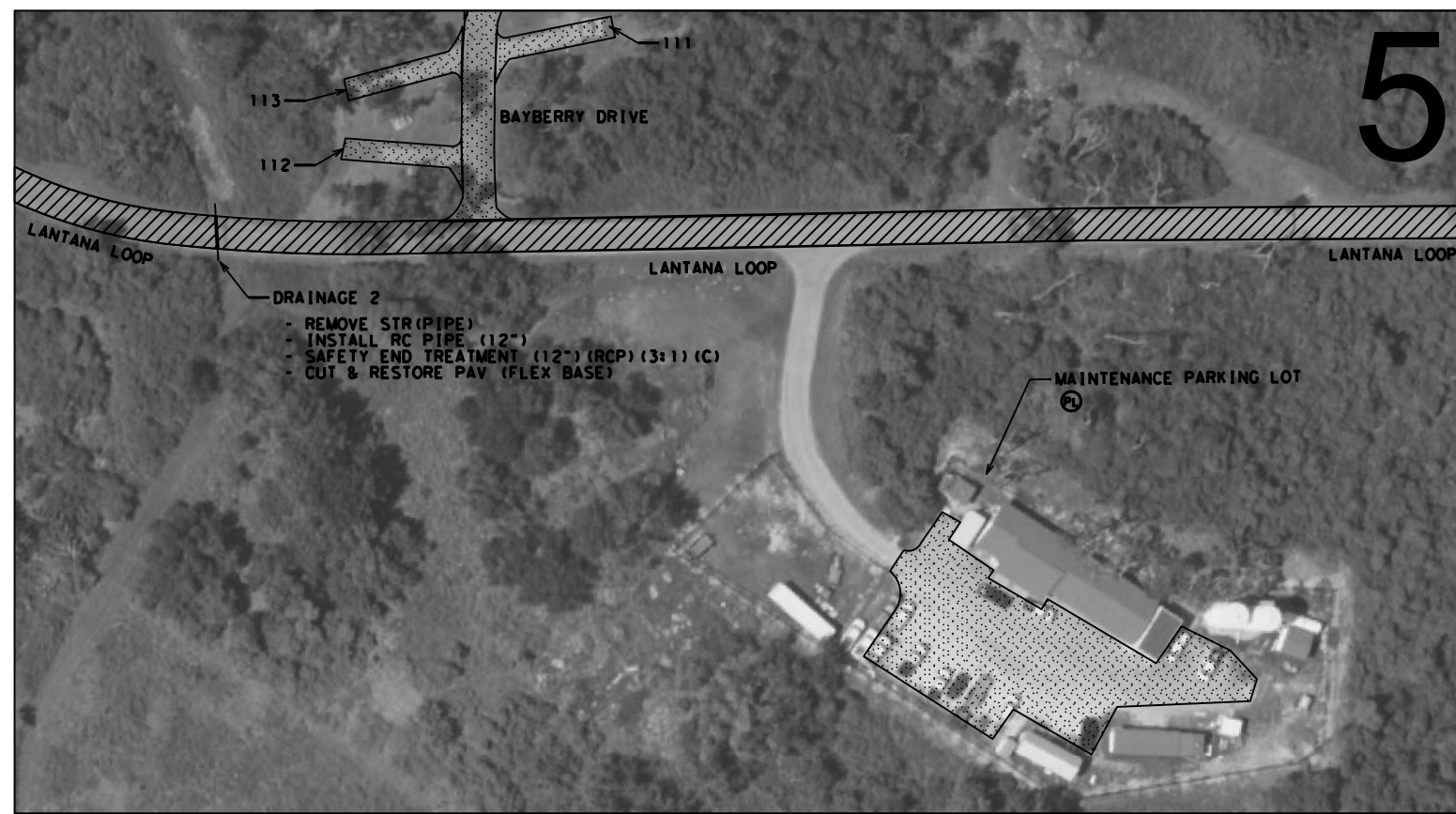

LEGEND

- BASE REPAIR
- HOT-MIX OVERLAY
- ACCESSIBLE COMPLIANT PARKING
- PARKING LOT
- RV BACK-IN LOT
- RV PULL-THROUGH
- DRIVEWAY

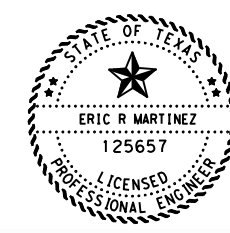

*E. Martinez*

01/13/2023

GOOSE ISLAND  
 STATE PARK  
 ROADWAY DETAILS

SHEET 5 OF 8

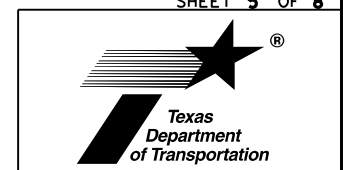



NOT TO SCALE

CONT	SECT	JOB	HIGHWAY
0916	28	071	PR 25A
DIST	COUNTY		SHEET NO.
CRP	SAN PATRICIO		49

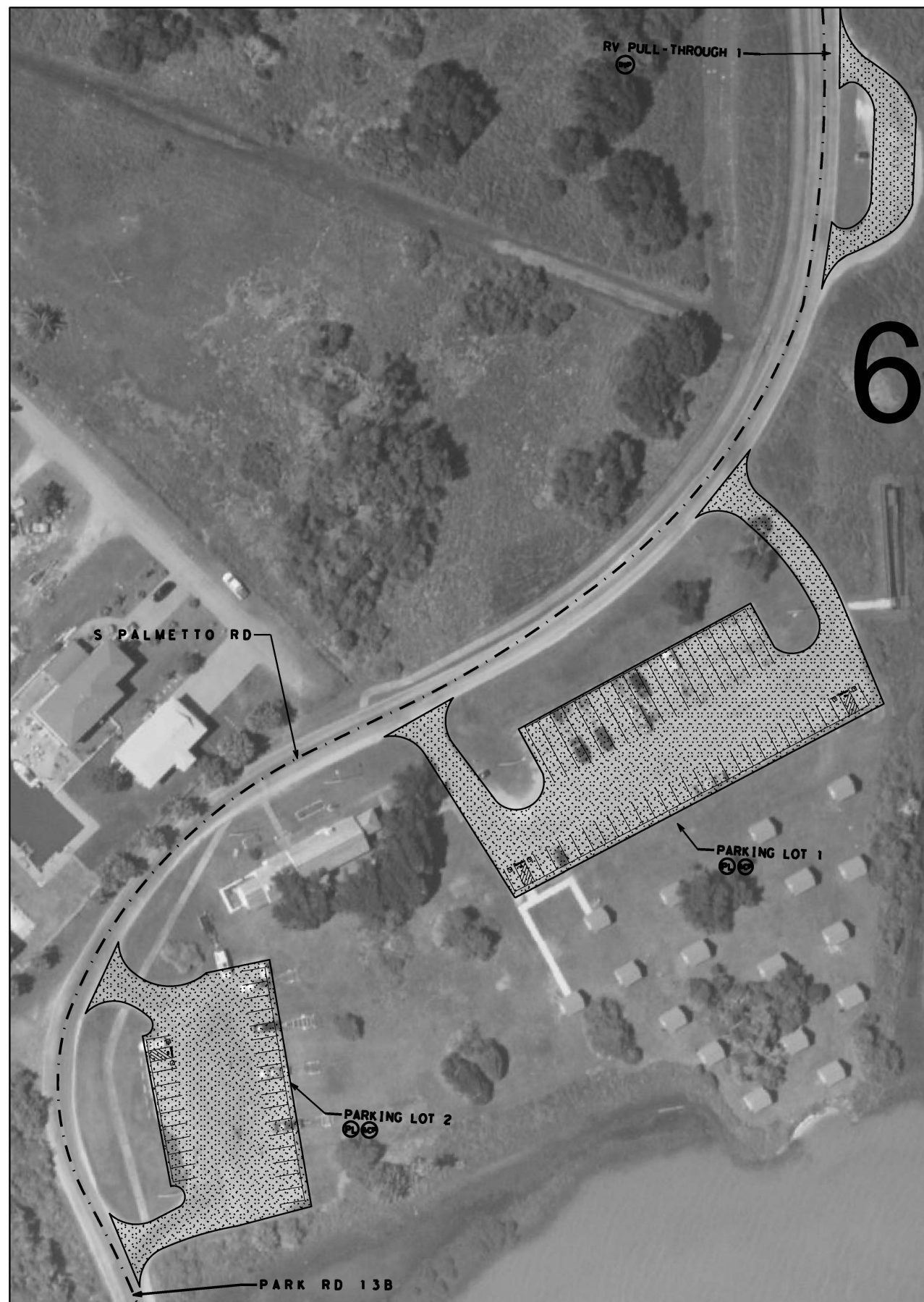
01/13/2023



LEGEND

-  - BASE REPAIR
-  - HOT-MIX OVERLAY
-  - ACCESSIBLE COMPLIANT PARKING
-  - PARKING LOT
-  - RV BACK-IN LOT
-  - RV PULL-THROUGH
-  - DRIVEWAY

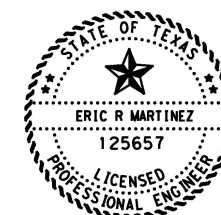

*E. Martinez, P.E.*

GOOSE ISLAND  
 STATE PARK  
 ROADWAY DETAILS

SHEET 6 OF 8







			
CONT	SECT	JOB	HIGHWAY
0916	28	071	PR 25A
DIST	COUNTY		SHEET NO.
CRP	SAN PATRICIO		50

NOT TO SCALE



01/13/2023

LEGEND

-  - BASE REPAIR
-  - HOT-MIX OVERLAY
-  - ACCESSIBLE COMPLIANT PARKING
-  - PARKING LOT
-  - RV BACK-IN LOT
-  - RV PULL-THROUGH
-  - DRIVEWAY



*E. Martinez*

GOOSE ISLAND  
 STATE PARK  
 ROADWAY DETAILS

SHEET 7 OF 8

NOT TO SCALE







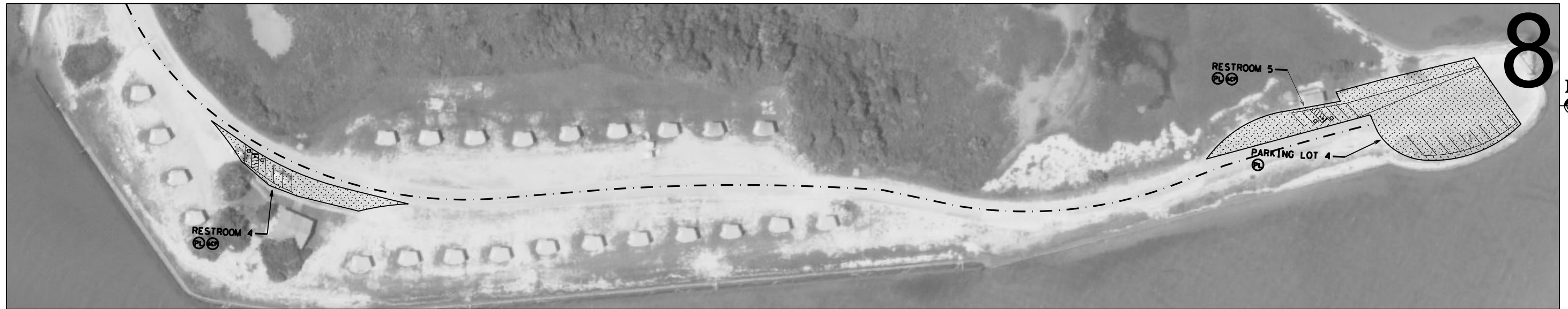

CONT	SECT	JOB	HIGHWAY
0916	28	071	PR 25A
DIST	COUNTY		SHEET NO.
CRP	SAN PATRICIO		51



DATE: 1/13/2023 5:21:06 PM  
 FILE: p:\txdot\projectwiseonline.com\txdot\Documents\16 - CRP\Design Projects\091628071\4 - Design\Plan Set\1. General\GOOSE ISLAND - ROCKPORT ANNEK/LAYOUT: SHEET\MS/GOOSE ISLAND



LEGEND

-  - BASE REPAIR
-  - HOT-MIX OVERLAY
-  - ACCESSIBLE COMPLIANT PARKING
-  - PARKING LOT
-  - RV BACK-IN LOT
-  - RV PULL-THROUGH
-  - DRIVEWAY

8

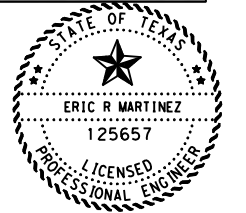

*E. Martinez*

01/13/2023

**GOOSE ISLAND  
 STATE PARK  
 ROADWAY DETAILS**

SHEET 8 OF 8



NOT TO SCALE

CONT	SECT	JOB	HIGHWAY
0916	28	071	PR 25A
DIST	COUNTY		SHEET NO.
CRP	SAN PATRICIO		52

DATE: 1/13/2023 5:21:21 PM  
 FILE: p:\t\dot\project\wiseonline.com\t\dot\4\Documents\16 - CRP\Design Projects\091628071\4 - Design\Plan Set\1. General\GOOSE ISLAND - ROCKPORT ANNEX\ROCKPORT ANNEX\_LAYOUT.dgn

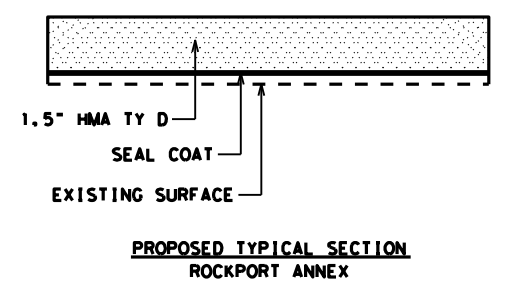
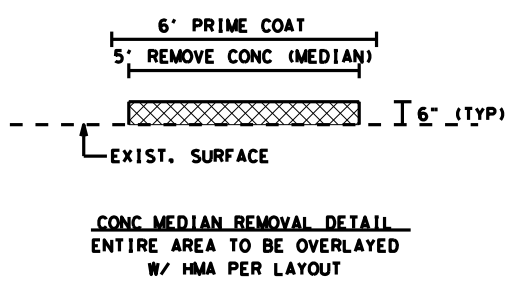
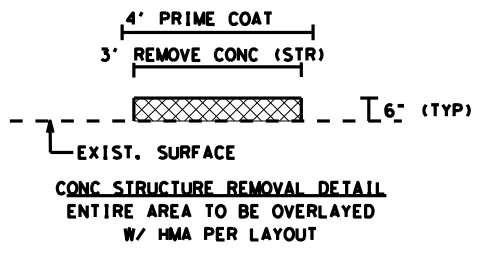

**LEGEND**

- CONC REMOVAL
- HOT-MIX OVERLAY



*E. Martinez*

01/13/2023

**ROCKPORT ANNEX  
 LAYOUT SHEET**

SHEET 1 OF 1

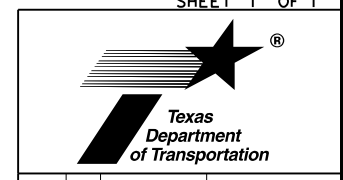

CONT	SECT	JOB	HIGHWAY
0916	28	071	PR 25A
DIST	COUNTY	SHEET NO.	
CRP	SAN PATRICIO	53	

NOT TO SCALE

DATE: 1/13/2023 5:21:39 PM  
 FILE: p:\t\tdot\projectwiseonline.com\txd014\Documents\16 - CRP\Design Projects\091628071\4 - Design\Plan Set\1. General\GOOSE ISLAND - ROCKPORT ANNEX\THE BIG TREE LAYOUT.dgn

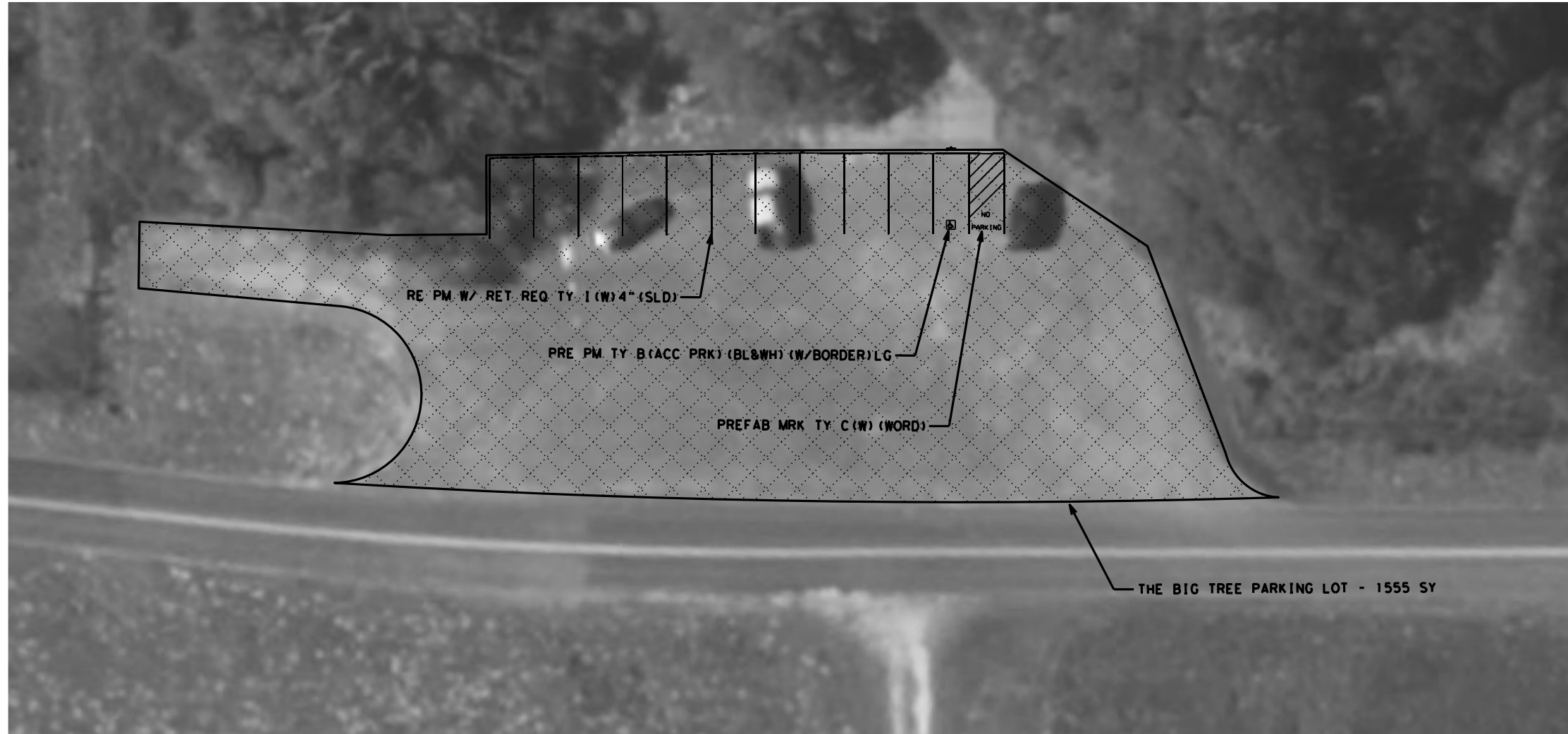

LEGEND

 - HOT-MIX OVERLAY

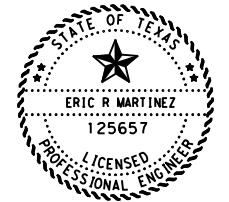

*E. Martinez*

01/13/2023

THE BIG TREE  
 LAYOUT SHEET

SHEET 1 OF 1

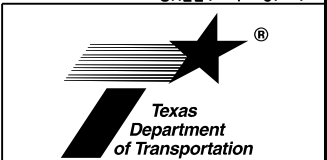

CONT	SECT	JOB	HIGHWAY
0916	28	071	PR 25A
DIST	COUNTY		SHEET NO.
CRP	SAN PATRICIO		54

NOT TO SCALE

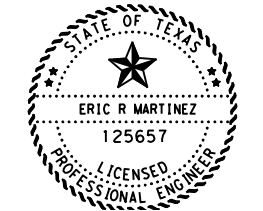
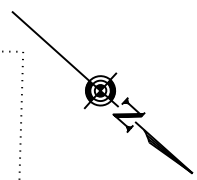
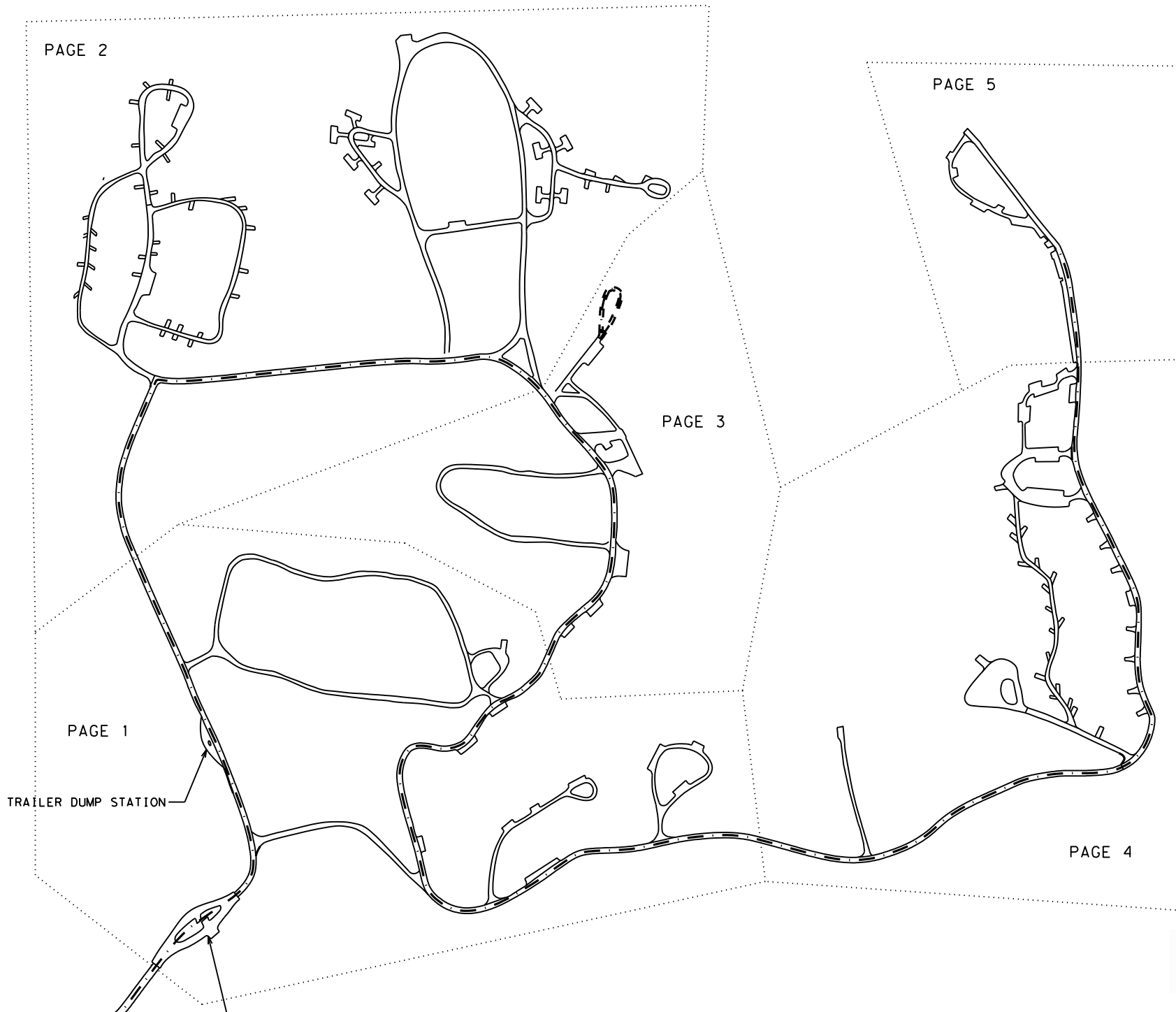

*E. Martinez*

01/13/2023

**LAKE CORPUS CHRISTI  
STATE PARK  
LAYOUT MAP**

NOT TO SCALE

SHEET 1 OF 1



CONT	SECT	JOB	HIGHWAY
0916	28	071	PR 25A
DIST	COUNTY		SHEET NO.
CRP	SAN PATRICIO		55

DATE: 2/1/2023 2:42:52 PM  
 FILE: D:\t\dot\project\wiseonline.com\TXDOT14\Documents\16 - CRP\Design Projects\091628071\4 - Design\Plan Set\3. Roadway\LAKE CC\LAKE CC LAYOUT2

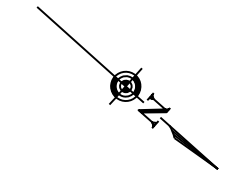
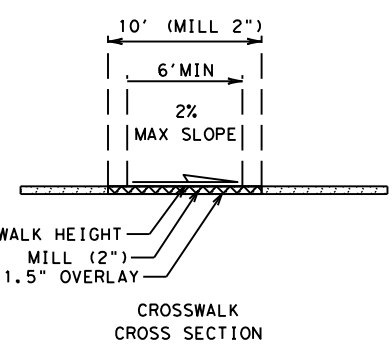
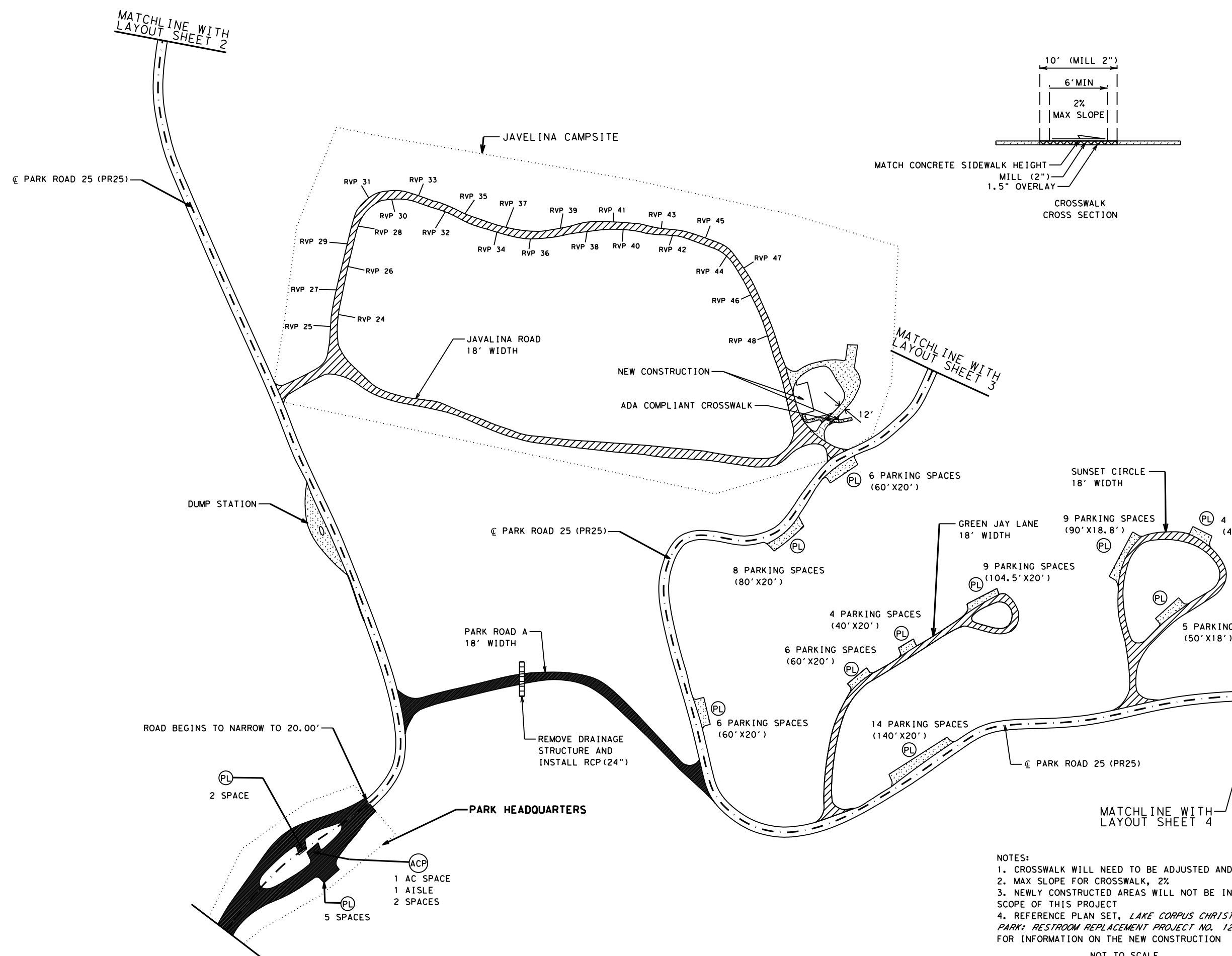

- LEGEND**
- Ⓐ - ACCESSIBLE COMPLAINT PARKING
  - Ⓟ - PARKING LOT
  - RVB - RV BACK-IN LOT
  - RVP - RV PULL-THROUGH
  - S - SHELTER'S DRIVEWAY
  - ▨ - BASE WORK
  - ▩ - HOT-MIX OVERLAY
  - - ONE COURSE SURFACE TREATMENT

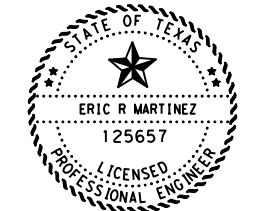

*E. Martinez*  
 02/06/2023

**LAKE CORPUS CHRISTI STATE PARK  
 ROADWAY DETAILS**

SHEET 1 OF 5

- NOTES:**
- CROSSWALK WILL NEED TO BE ADJUSTED AND STRIPED
  - MAX SLOPE FOR CROSSWALK, 2%
  - NEWLY CONSTRUCTED AREAS WILL NOT BE IN THE SCOPE OF THIS PROJECT
  - REFERENCE PLAN SET, LAKE CORPUS CHRISTI STATE PARK: RESTROOM REPLACEMENT PROJECT NO. 1210196A. FOR INFORMATION ON THE NEW CONSTRUCTION

NOT TO SCALE

CONT	SECT	JOB	HIGHWAY
0916	28	071	PR 25A
DIST	COUNTY		SHEET NO.
CRP	SAN PATRICIO		56

DATE: 1/13/2023 5:22:16 PM  
 FILE: pw://twdot.projectwiseonline.com:txdot4/Documents/16 - CRP/Design Projects/091628071/4 - Design/Plan Set/3. Roadway/LAKE\_CC/LAKE\_CC\_LAYOUT3

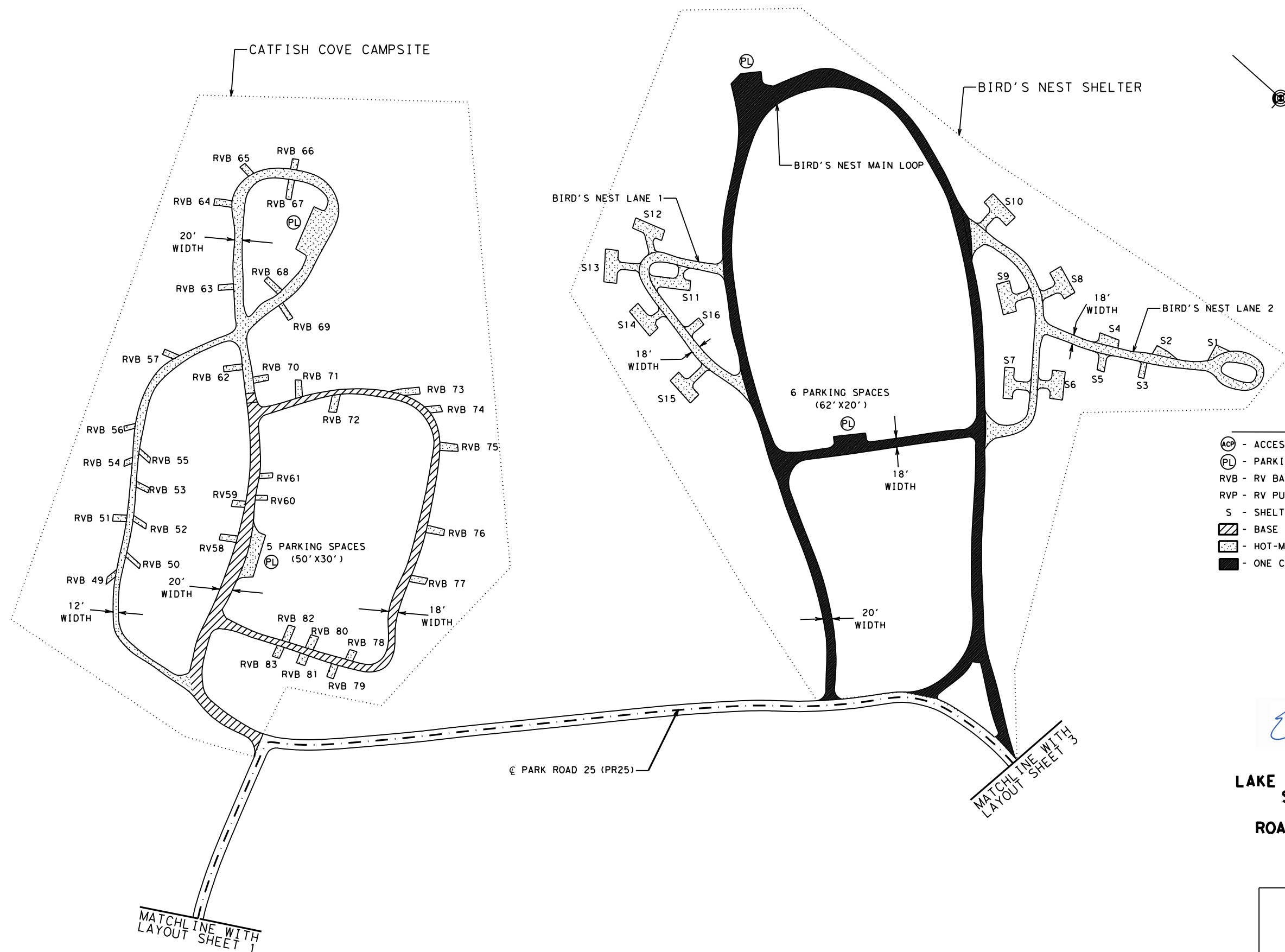

- LEGEND**
- (ACP) - ACCESSIBLE COMPLAINT PARKING
  - (PL) - PARKING LOT
  - RVB - RV BACK-IN LOT
  - RVP - RV PULL-THROUGH
  - S - SHELTER'S DRIVEWAY
  - [Hatched] - BASE WORK
  - [Dotted] - HOT-MIX OVERLAY
  - [Solid Black] - ONE COURSE SURFACE TREATMENT



*Eric R. Martinez*

01/13/2023  
**LAKE CORPUS CHRISTI STATE PARK**  
**ROADWAY DETAILS**

SHEET 2 OF 5

CONT	SECT	JOB	HIGHWAY
0916	28	071	PR 25A
DIST	COUNTY	SHEET NO.	
CRP	SAN PATRICIO	57	

NOT TO SCALE

DATE: 1/13/2023 5:22:26 PM  
 FILE: p:\t\dot\project\wiseonline.com\txdot\Documents\16 - CRP\Design Projects\091628071\4 - Design\Plan Set\3. Roadway\LAKE CC\LAKE CC LAYOUT4

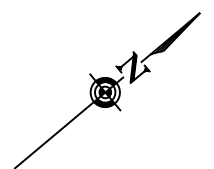
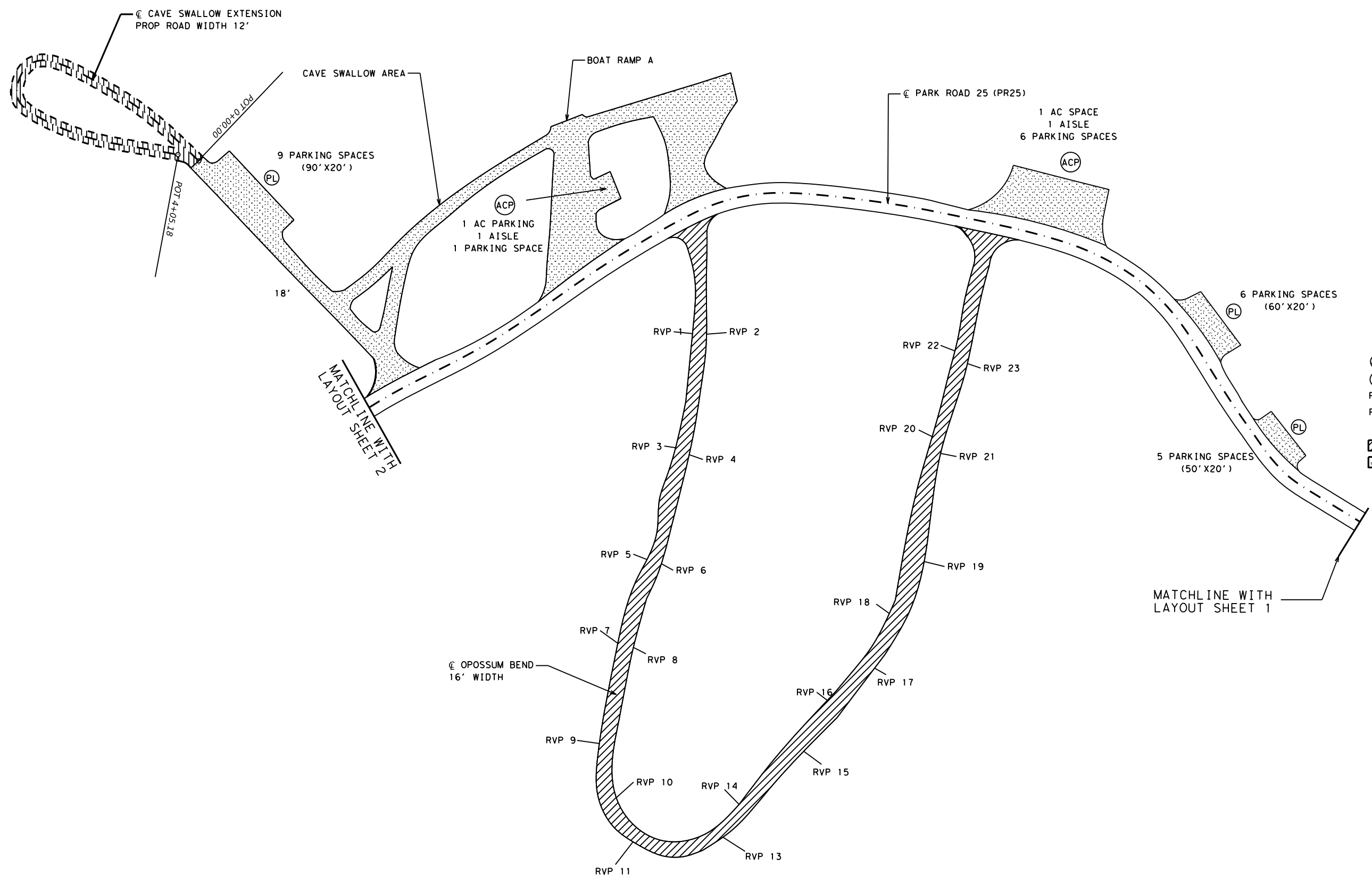

- LEGEND**
- ACP - ACCESSIBLE COMPLAINT PARKING
  - PL - PARKING LOT
  - RVB - RV BACK-IN LOT
  - RVP - RV PULL-THROUGH
  - S - SHELTER'S DRIVEWAY
  - BASE WORK
  - HOT-MIX OVERLAY

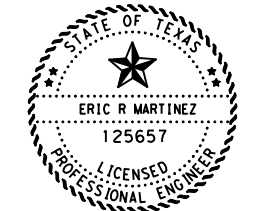

*E. Martinez*

01/13/2023

**LAKE CORPUS CHRISTI  
STATE PARK  
ROADWAY DETAILS**

SHEET 3 OF 5



CONT	SECT	JOB	HIGHWAY
0916	28	071	PR 25A
DIST	COUNTY	SHEET NO.	
CRP	SAN PATRICIO	58	

NOT TO SCALE

DATE: 1/13/2023 5:22:35 PM  
 FILE: \\txdot.projectwiseonline.com:txdot14\Documents\16 - CRP\Design Projects\091628071\4 - Design\Plan Set\3. Roadway\LAKE\_CC\LAKE\_CC\_LAYOUT5

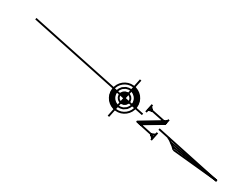
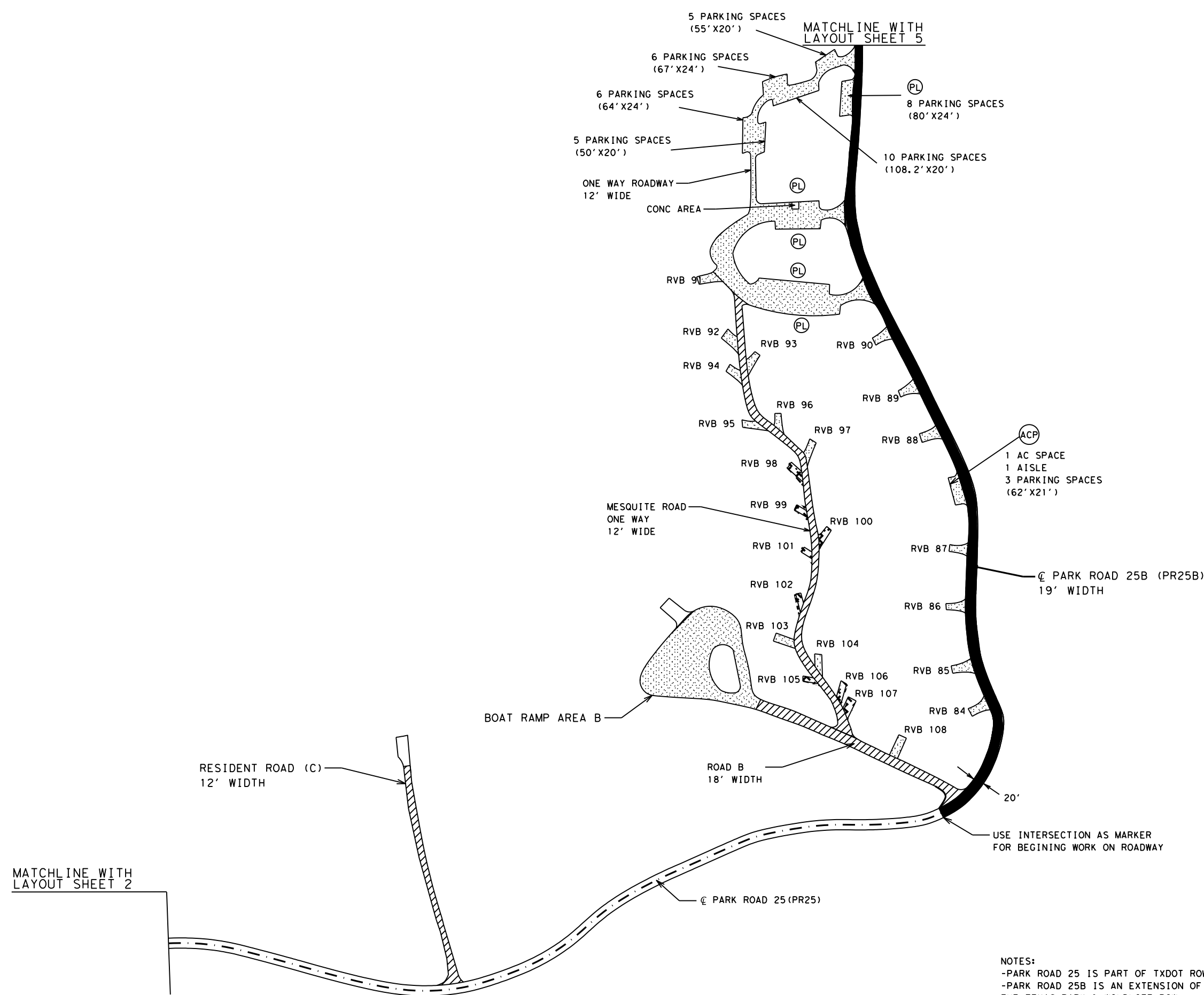

- LEGEND**
- Ⓐ - ACCESSIBLE COMPLAINT PARKING
  - Ⓟ - PARKING LOT
  - RVB - RV BACK-IN LOT
  - RVP - RV PULL-THROUGH
  - S - SHELTER'S DRIVEWAY
  - ▨ - BASE WORK
  - ▩ - HOT-MIX OVERLAY

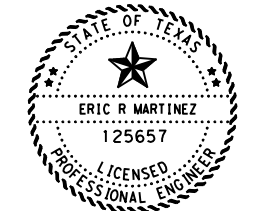

*E. Martinez*

01/13/2023

**LAKE CORPUS CHRISTI STATE PARK**

**LAYOUT SHEET**

SHEET 4 OF 5

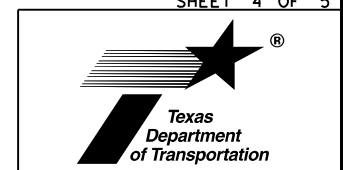

**NOTES:**  
 -PARK ROAD 25 IS PART OF TXDOT ROW  
 -PARK ROAD 25B IS AN EXTENSION OF PR25 AND FALLS UNDER THE TEXAS PARK & WILDLIFE ROW  
 -NOT TO SCALE

CONT	SECT	JOB	HIGHWAY
0916	28	071	PR 25A
DIST	COUNTY	SHEET NO.	
CRP	SAN PATRICIO	59	



DATE: 1/13/2023 5:22:44 PM  
 FILE: p:\t\dot\project\wiseonline.com\txdot\Documents\16 - CRP\Design Projects\091628071\4 - Design\Plan Set\3. Roadway\LAKE\_CC\LAKE\_CC\_LAYOUT6

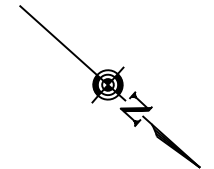
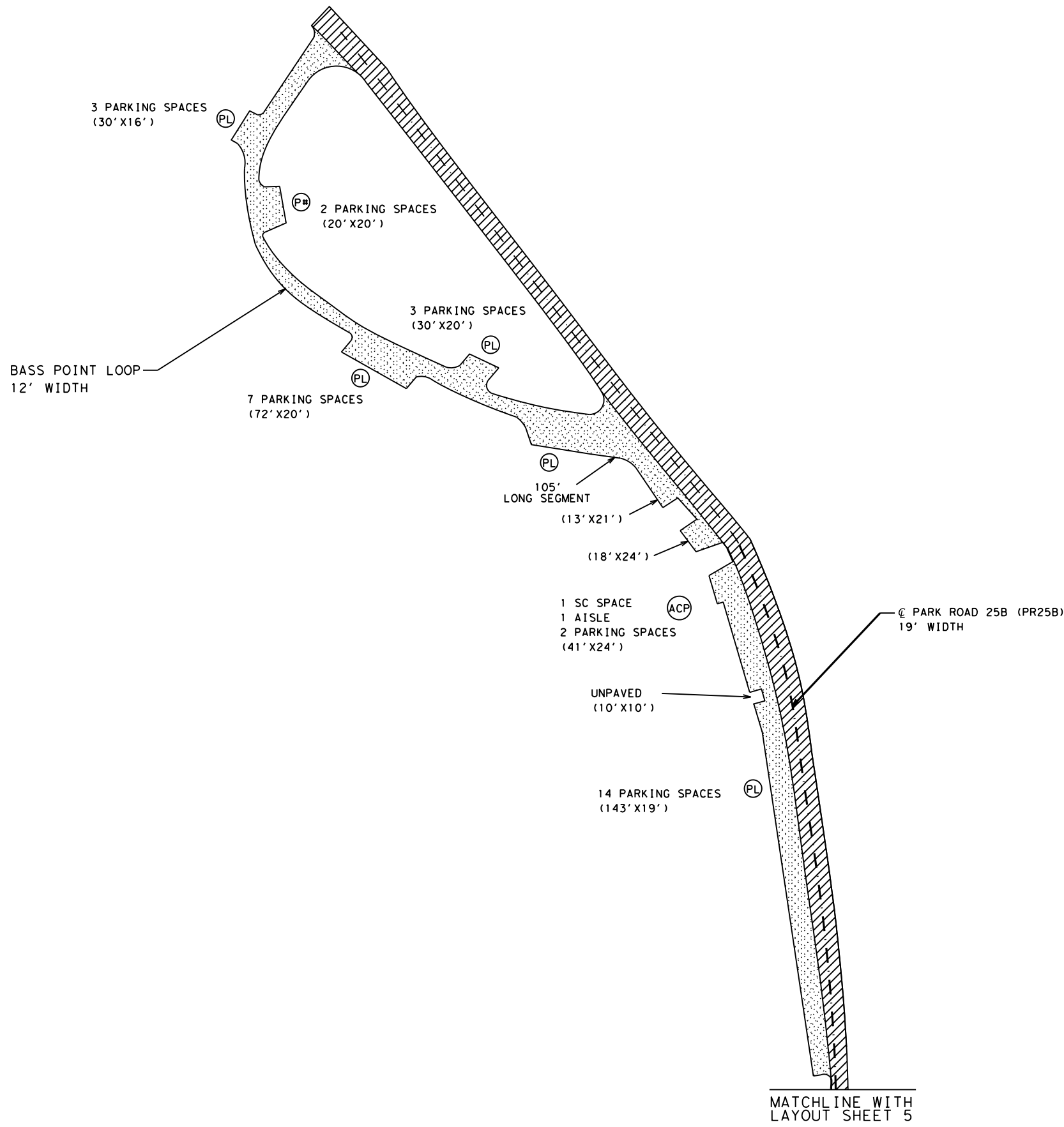

- LEGEND**
- Ⓐ - ACCESSIBLE COMPLAINT PARKING
  - Ⓟ - PARKING LOT
  - RVB - RV BACK-IN LOT
  - RVP - RV PULL-THROUGH
  - S - SHELTER'S DRIVEWAY
  - ▨ - BASE WORK
  - ▩ - HOT-MIX OVERLAY

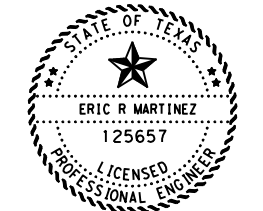

*Eric R. Martinez*

01/13/2023

**LAKE CORPUS CHRISTI STATE PARK**

**LAYOUT SHEET**

SHEET 5 OF 5

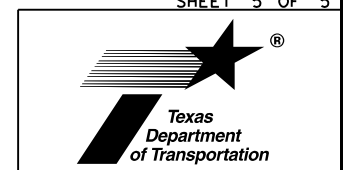

NOT TO SCALE

CONT	SECT	JOB	HIGHWAY
0916	28	071	PR 25A
DIST	COUNTY		SHEET NO.
CRP	SAN PATRICIO		60

DISCLAIMER:  
 The use of this standard is governed by the "Texas Engineering Practice Act". No warranty of any kind is made by TxDOT for any purpose whatsoever. TxDOT assumes no responsibility for the conversion of this standard to other formats or for incorrect results or damages resulting from its use.

DATE: 1/13/2023  
 FILE: pw://txdot.projectwiseonline.com:txdot4/Documents/16 - CRP/Design Projects/091628071/4 - Design/Plan Set/13. Standards/TE (HMAC) - 11.dgn

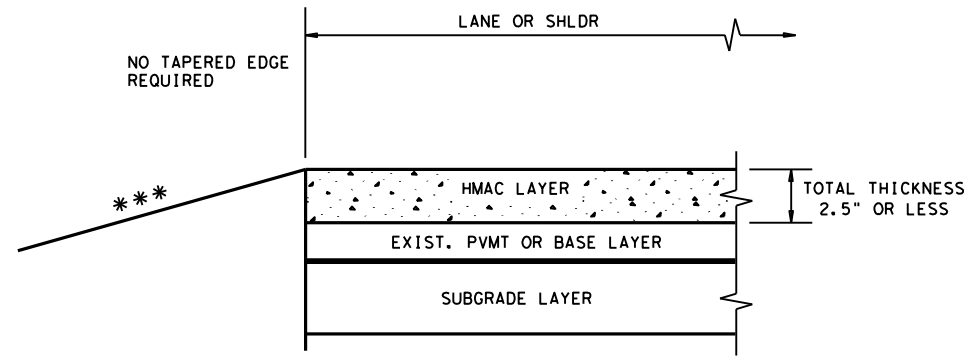

\*\*\* SEE TYPICAL SECTION FOR ROADSIDE DETAILS

**CONDITION - 1**  
 THIN HMAC SURFACES OR HMAC OVERLAY  
 WITH THICKNESS OF 2.5" OR LESS

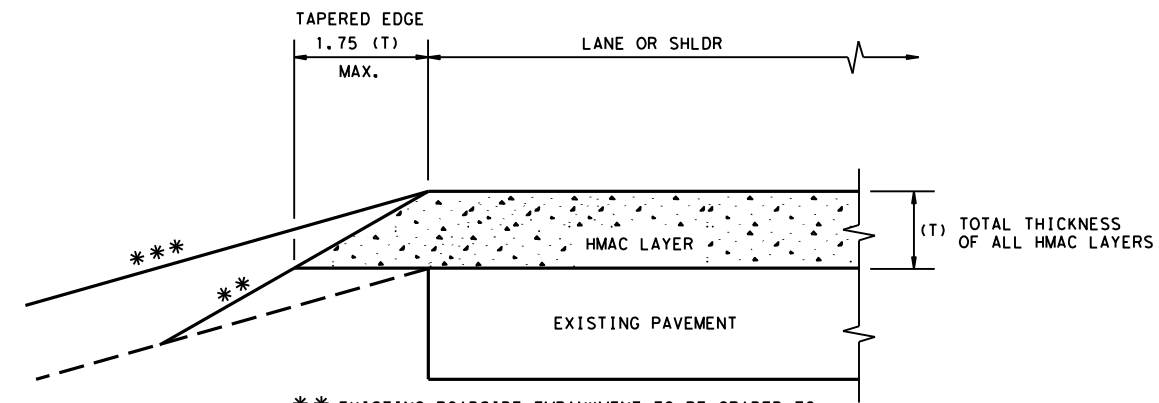

\*\* EXISTING ROADSIDE EMBANKMENT TO BE GRADED TO PRODUCE A SMOOTH LEVEL SURFACE FOR PLACEMENT OF TAPERED EDGE. THIS WORK IS SUBSIDIARY TO THE VARIOUS BID ITEMS.

\*\*\* SEE TYPICAL SECTION FOR ROADSIDE DETAILS

**CONDITION - 2**  
 OVERLAY OF EXISTING PAVEMENT  
 HMAC THICKNESS 2.5" TO 5"

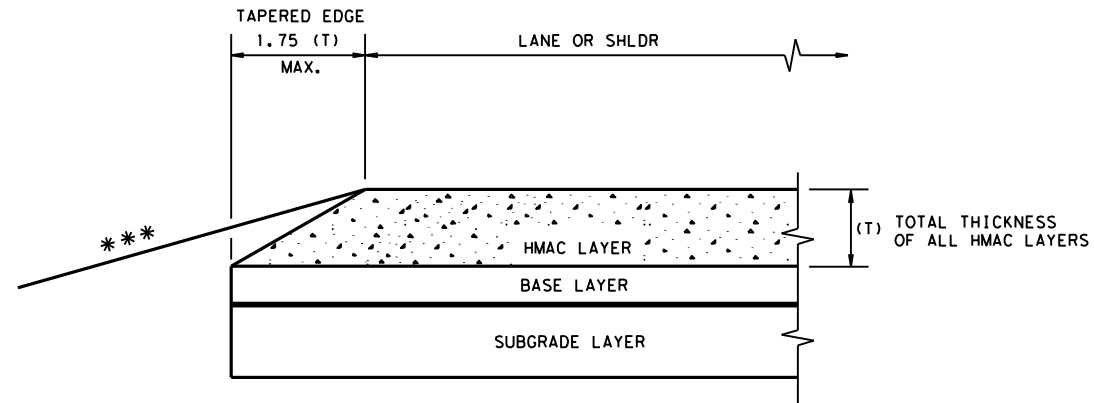

\*\*\* SEE TYPICAL SECTION FOR ROADSIDE DETAILS

**CONDITION - 3**  
 NEW OR RECONSTRUCTED PAVEMENT  
 HMAC THICKNESS 2.5" TO 5"

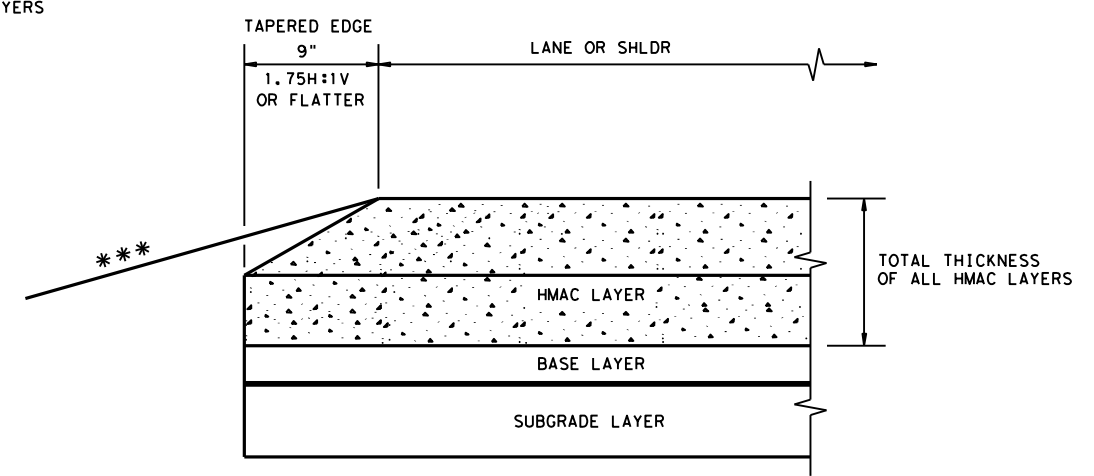

\*\*\* SEE TYPICAL SECTION FOR ROADSIDE DETAILS

**CONDITION - 4**  
 NEW OR RECONSTRUCTED PAVEMENT  
 HMAC THICKNESS 5" OR GREATER

**GENERAL NOTES**

1. UNLESS OTHERWISE SHOWN IN THE PLANS, A VERTICAL EDGE IS PERMISSIBLE FOR HMAC PLACED GREATER THAN 5" BELOW THE EDGE OF PAVEMENT AND FOR THICKNESS OF HMAC LESS THAN 2.5".
2. FOR FURTHER INFORMATION REGARDING THE ROADSIDE AND PAVEMENT DETAILS, SEE TYPICAL SECTIONS.
3. PAYMENT FOR TAPERED EDGE WILL BE IN ACCORDANCE WITH APPLICABLE ITEMS IN THE CONTRACT.
4. THE SLOPE OF THE TAPERED EDGE SHALL BE 1.75H:1V OR FLATTER.
5. THE TAPERED EDGE SHALL BE PRODUCED BY USE OF A SCREED ATTACHMENT CAPABLE OF PRODUCING A SMOOTH COMPACTED SURFACE. ADDITIONAL COMPACTING EFFORT BEHIND THE SCREED IS NOT REQUIRED.

(NOT TO SCALE)

					Design Division Standard
<b>TAPERED EDGE DETAILS          HMAC PAVEMENT</b>					
<b>TE (HMAC) - 11</b>					
FILE: tehmac11.dgn	DN: TxDOT	CK: RL	DW: KB	CK:	
© TxDOT January 2011	CONT	SECT	JOB	HIGHWAY	
REVISIONS		0916 28	071	PR 25A	
DIST	COUNTY	SHEET NO.			
CRP	SAN PATRICIO	61			

DATE: 1/13/2023 5:23:02 PM  
 FILE: //txdot.projectwiseonline.com:txdot4/ Documents/16 - CRP/Design Projects/091628/091628.dgn  
 The use of this standard is governed by the "Texas Engineering Practice Act". No warranty of any kind is made by TxDOT for any purpose whatsoever. TxDOT assumes no responsibility for the conversion of any information from a paper format to a digital format.

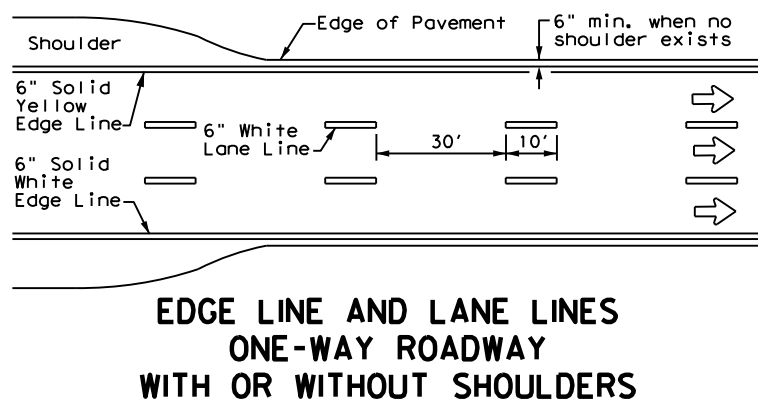

**EDGE LINE AND LANE LINES  
ONE-WAY ROADWAY  
WITH OR WITHOUT SHOULDERS**

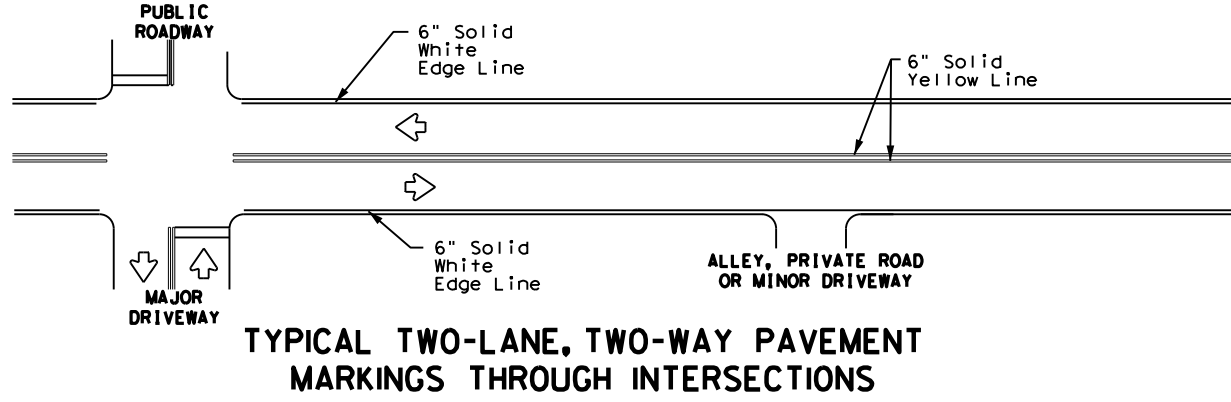

**TYPICAL TWO-LANE, TWO-WAY PAVEMENT  
MARKINGS THROUGH INTERSECTIONS**

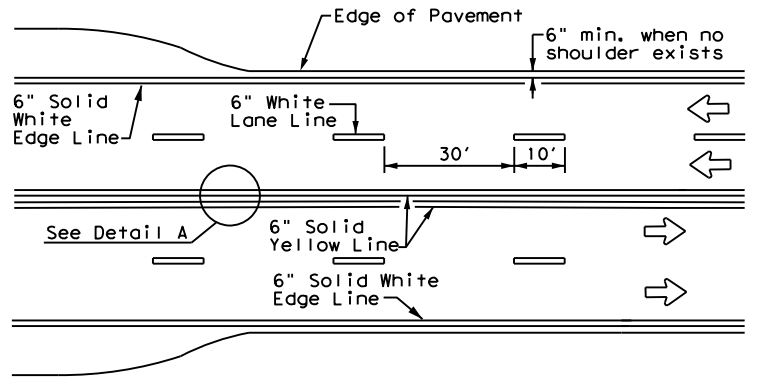

**CENTERLINE AND LANE LINES  
FOUR LANE TWO-WAY ROADWAY  
WITH OR WITHOUT SHOULDERS**

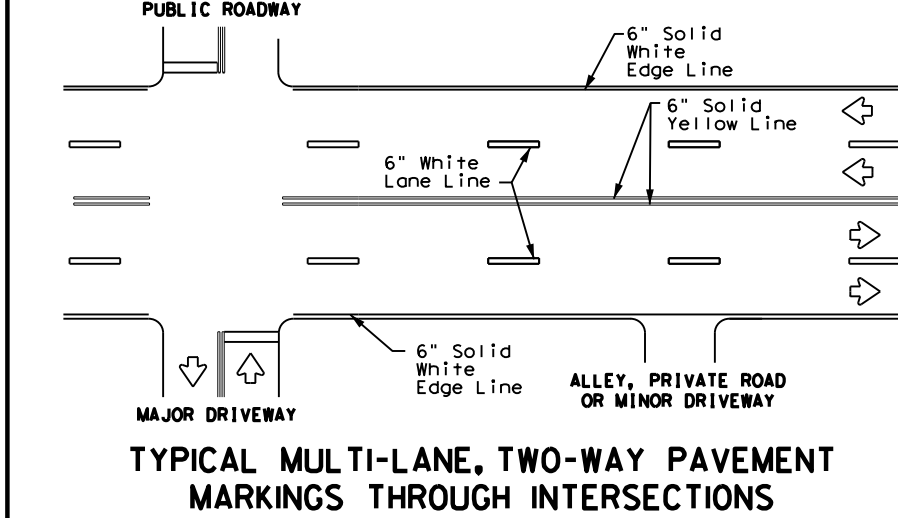
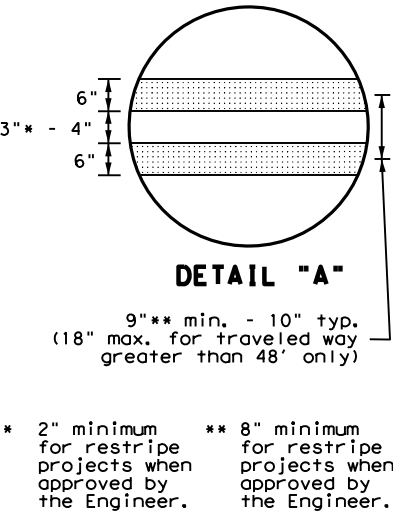

**TYPICAL MULTI-LANE, TWO-WAY PAVEMENT  
MARKINGS THROUGH INTERSECTIONS**

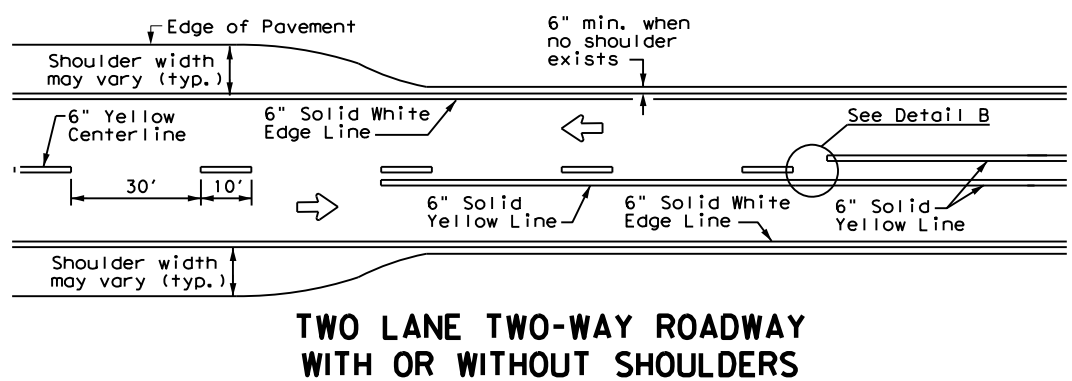

**TWO LANE TWO-WAY ROADWAY  
WITH OR WITHOUT SHOULDERS**

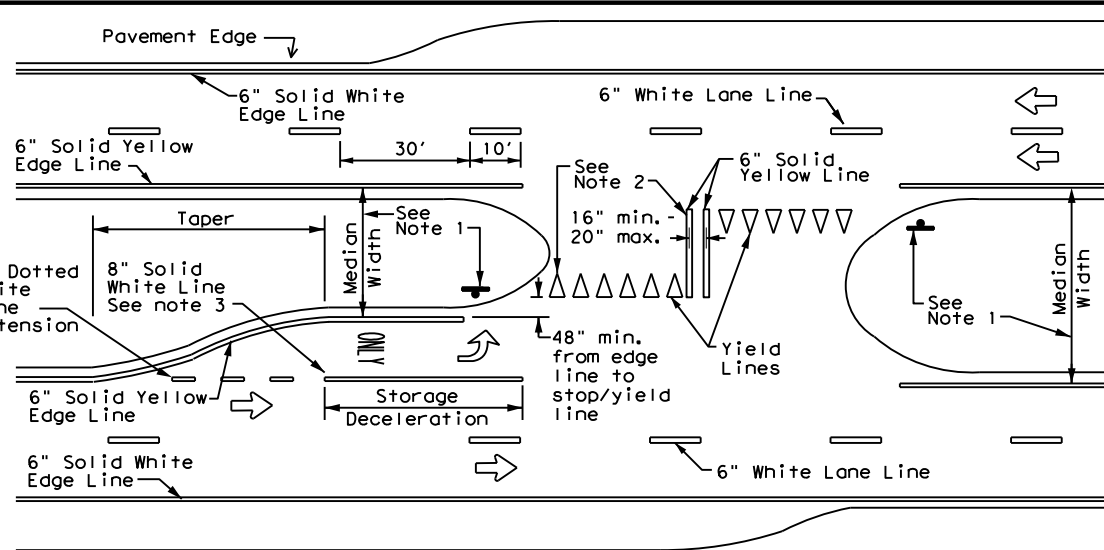
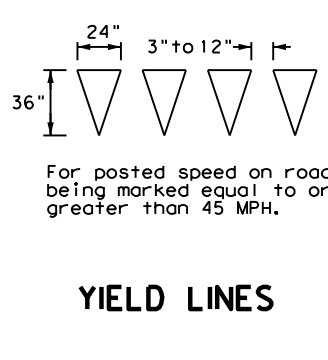
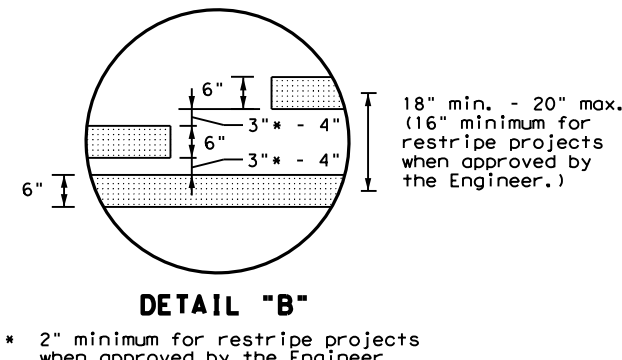

**FOUR LANE DIVIDED ROADWAY CROSSOVERS**

**NOTES**

- Where divided highways are separated by median widths at the median opening itself of 30 feet or more, median openings shall be signed as two separate intersections. Each median opening has two width measurements, with one measurement for each approach. The narrow median width will be the controlling width to determine if signs are required. Yield signs are the typical intersection control. Stop signs and stop bars are optional as determined by the Engineer.
- Install median striping (double yellow centerlines and stop lines/yield lines) when a 50' or greater median centerline can be placed. Stop lines shall only be used with stop signs. Yield lines shall only be used with yield signs.
- Length of turn bays, including taper, deceleration, and storage lengths shall be as shown on the plans or as directed by the Engineer.

**GENERAL NOTES**

- Edge line striping shall be as shown in the plans or as directed by the Engineer. The edge line should not be placed less than 6 inches from the edge of pavement. This distance may vary due to pavement raveling or other conditions. Edge lines are not required in curb and gutter sections of roadways.
- The traveled way includes only that portion of the roadway used for vehicular travel. It does not include the parking lanes, sidewalks, berms and shoulders. The traveled ways shall be measured from the center of edge line to the center of edge line of a two lane roadway.

MATERIAL SPECIFICATIONS	
PAVEMENT MARKERS (REFLECTORIZED)	DMS-4200
EPOXY AND ADHESIVES	DMS-6100
BITUMINOUS ADHESIVE FOR PAVEMENT MARKERS	DMS-6130
TRAFFIC PAINT	DMS-8200
HOT APPLIED THERMOPLASTIC	DMS-8220
PERMANENT PREFABRICATED PAVEMENT MARKINGS	DMS-8240

All pavement marking materials shall meet the required Departmental Material Specifications as specified by the plans.

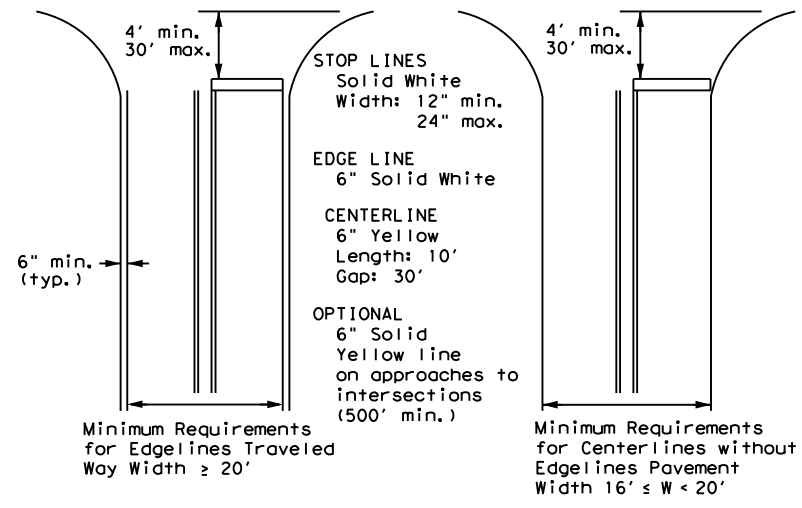

NOTE: Traveled way is exclusive of shoulder widths. Refer to General Note 2 for additional details.

**GUIDE FOR PLACEMENT OF STOP LINES,  
EDGE LINE & CENTERLINE**  
 Based on Traveled Way and Pavement Widths for Undivided Roadways



**TYPICAL STANDARD  
PAVEMENT MARKINGS**

**PM(1) - 22**

FILE: pm1-22.dgn	DN:	CK:	DW:	CK:
© TxDOT December 2022	CONT	SECT	JOB	HIGHWAY
REVISIONS	0916	28	071	PR 25A
11-78 8-00 6-20	DIST	COUNTY	SHEET NO.	
8-95 3-03 12-22	CRP	SAN PATRICIO	62	
5-00 2-12				

DISCLAIMER: The use of this standard is governed by the "Texas Engineering Practice Act". No warranty of any kind is made by TxDOT for any purpose whatsoever. TxDOT assumes no responsibility for the conversion of units or for the accuracy of the information contained herein. TxDOT is not responsible for any errors or omissions in this document.

DATE: 1/13/2023 5:23:11 PM  
 FILE: \\txdot.projectwiseonline.com\txdot\4\Documents\16 - CRP\Design Project\091628\071\PR 25A\091628\071\PR 25A.dwg

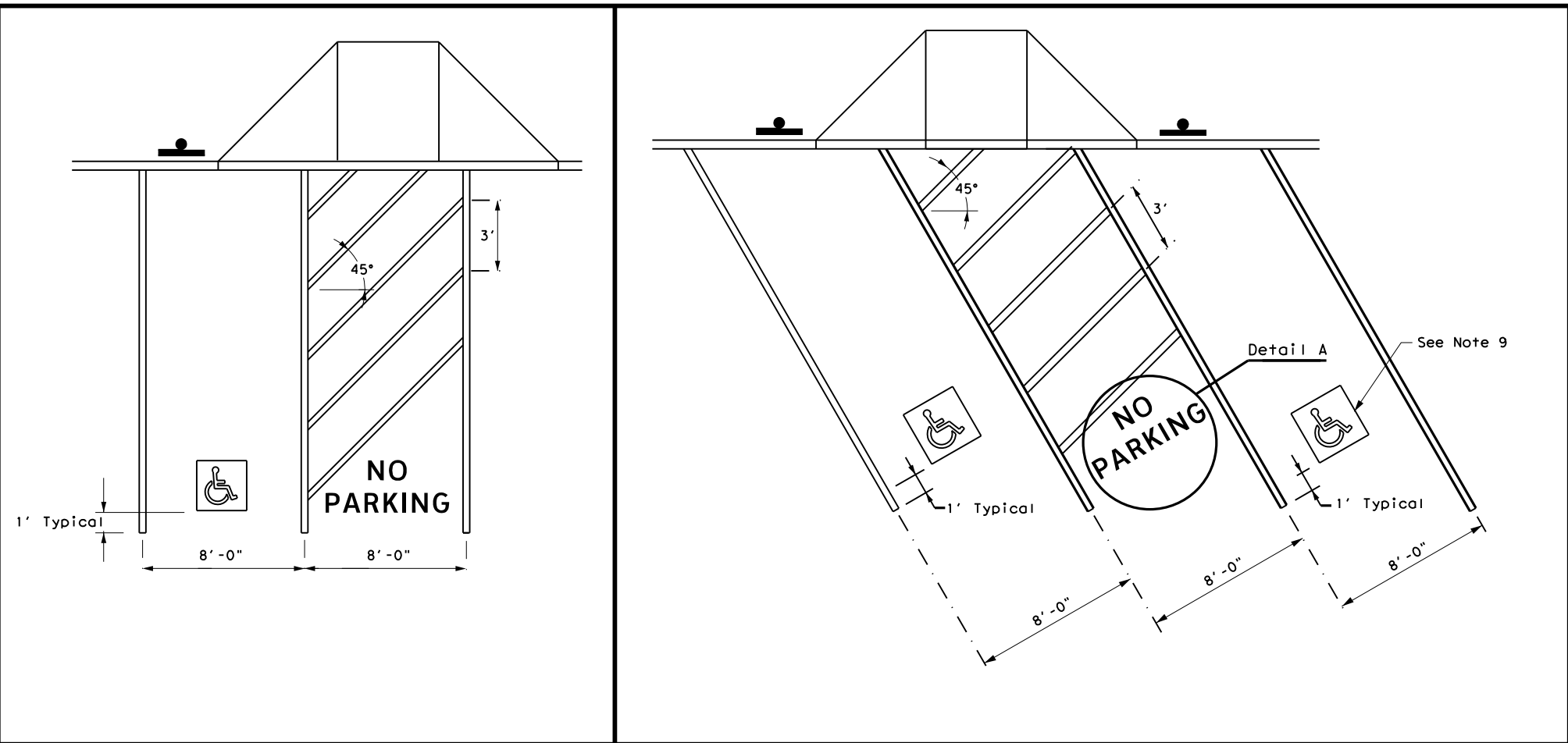

PERPENDICULAR OR ANGLED ACCESSIBLE PARKING SPACE DIMENSIONS

GENERAL NOTES:

1. All paved accessible parking space limit lines shall be 4" solid white lines.
2. Paved accessible parking spaces must include a white International Symbol of Accessibility applied conspicuously on the surface in a color that contrasts the pavement. A blue background with white border may supplement the symbol for additional contrast.
3. The words "NO PARKING" must be applied on any access aisle adjacent to the parking space. The words must be white, applied:
  - a) in all capital letters.
  - b) centered within each access aisle adjacent to the parking space.
4. RESERVED PARKING (R7-8T) sign including the International Symbol of Accessibility.
  - a) shall be REQUIRED for each accessible parking space.
  - b) shall NOT be placed between two accessible parking spaces.
  - c) shall NOT be placed in a location that restricts movement of wheelchairs within the adjacent sidewalk.
  - d) shall have a mounting height of 7 feet to the bottom of the sign.
5. A sign identifying the consequences of parking illegally in a paved accessible parking space. Must:
  - a) at a minimum state "VIOLATORS SUBJECT TO FINE AND TOWING" (Plaque) (R7-8aPT).
  - b) be mounted on a pole, post, wall or freestanding board.
  - c) be no more than eight inches (8") below sign R7-8T a sign required by the Texas Accessibility Standards, 502.6.
  - d) be installed so that the bottom edge of the sign is no lower than 48 inches and no higher than 80 inches above the ground level.
6. Signs identifying van parking spaces shall contain the designation "VAN ACCESSIBLE" (R7-8P) Signs shall be 60 inches minimum above the ground level measured to the bottom of the sign.
7. Perpendicular or angled parking spaces shall be 8 feet wide minimum with an access aisle 8 feet minimum wide (van accessible). Two parking spaces are permitted to share a common access aisle.
8. Access aisles shall be at street level, extend the full length of the parking space they serve, follow ADA surface requirements, and marked to discourage parking in the access aisle. Curb ramps shall connect the access aisle to the adjacent pedestrian access route. Curb ramps shall not be located within the access aisle.
9. International Symbol of Accessibility Parking Space Marking and sign details can be found in The Standard Highway Sign Designs for Texas (SHSD) at the following website. <http://www.txdot.gov/>



R7-8T



R7-8P

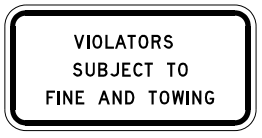

R7-8aPT

ACCESSIBLE PARKING SIGNS



Detail A

ALUMINUM SIGN BLANKS THICKNESS	
Square Feet	Minimum Thickness
Less than 7.5	0.080
7.5 to 15	0.100
Greater than 15	0.125

DEPARTMENTAL MATERIAL SPECIFICATIONS	
ALUMINUM SIGN BLANKS	DMS-7110
TRAFFIC PAINT	DMS-8200
HOT APPLIED THERMOPLASTIC	DMS-8220
PERMANENT PREFABRICATED PAVEMENT MARKINGS	DMS-8240
SIGN FACE MATERIALS	DMS-8300

Texas Department of Transportation

Traffic Safety Division Standard

## PAVEMENT MARKINGS AND SIGNING FOR ACCESSIBLE PARKING

### PM(AP) - 21

FILE: pm(ap)-21	DN: TxDOT	CK: TxDOT	DW: TxDOT	CR: TxDOT
© TxDOT July 2021	CONT	SECT	JOB	HIGHWAY
REVISIONS	091628	071	PR 25A	
DIST	COUNTY	SHEET NO.		
CRP	SAN PATRICIO	63		

**STORMWATER POLLUTION PREVENTION PLAN (SWP3):**

This SWP3 has been developed in accordance with the TPDES Construction General Permit TXR150000 (CGP). The Texas Department of Transportation (TxDOT) ensures that project specifications include adequate best management practices (BMPs) for this project.

For all projects with any soil disturbing activities, TxDOT will maintain a SWP3 with all pertinent records, correspondence, environmental documents, etc. at the project field office. If no field office is available, then this SWP3 shall be kept in the appropriate TxDOT Area Office.

This SWP3 is consistent with requirements specified in applicable stormwater plans and the projects environmental permits, issues, and commitments (EPICs). A copy of the CGP is included in Attachment 2.12 of the SWP3 binder.

**1.0 SITE/PROJECT DESCRIPTION**

**1.1 PROJECT CONTROL SECTION JOB (CSJ):**

0916-28-071

**1.2 PROJECT LIMITS:**

From: \_\_\_\_\_

To: \_\_\_\_\_

**1.3 PROJECT COORDINATES:**

BEGIN: (Lat)\_\_\_\_\_,(Long)\_\_\_\_\_

END: (Lat)\_\_\_\_\_,(Long)\_\_\_\_\_

**1.4 TOTAL PROJECT AREA (Acres):** \_\_\_\_\_

**1.5 TOTAL AREA TO BE DISTURBED (Acres):** \_\_\_\_\_

**1.6 NATURE OF CONSTRUCTION ACTIVITY:**

ROADWAY REHAB, OVERLAY, SURFACE TREATMENT AND UPGRADE EXISTING DRAINAGE STRUCTURES.

**1.7 MAJOR SOIL TYPES:**

Soil Type	Description

**1.8 PROJECT SPECIFIC LOCATIONS (PSLs):**

PSLs must be depicted on the Environmental Layout Sheets in Attachment 1.2 of this SWP3. PSLs may be identified during preconstruction meetings or during the construction process. Please choose from the options below:

- PSLs determined during preconstruction meeting
- PSLs determined during construction
- No PSLs planned for construction

Type	Sheet #s

All off-ROW PSLs required by the Contractor are the Contractor's responsibility. The Contractor shall secure all permits required by local, state, federal laws for off-ROW PSLs. The contractor shall provide diagrams, areas of disturbance, acreage, and BMPs for all off-ROW PSLs within one mile of the project.

**1.9 CONSTRUCTION ACTIVITIES:**

(Use the following list as a starting point when developing the Construction Activity Schedule and Ceasing Record in Attachment 2.5.)

- Mobilization
- Install sediment and erosion controls
- Blade existing topsoil into windrows, prep ROW, clear and grub
- Remove existing pavement
- Grading operations, excavation, and embankment
- Excavate and prepare subgrade for proposed pavement widening
- Remove existing culverts, safety end treatments (SETs)
- Remove existing metal beam guard fence (MBGF), bridge rail
- Install proposed pavement per plans
- Install culverts, culvert extensions, SETs
- Install mow strip, MBGF, bridge rail
- Place flex base
- Rework slopes, grade ditches
- Blade windrowed material back across slopes
- Revegetation of unpaved areas
- Achieve site stabilization and remove sediment and erosion control measures
- Other: \_\_\_\_\_
- Other: \_\_\_\_\_
- Other: \_\_\_\_\_

**1.10 POTENTIAL POLLUTANTS AND SOURCES:**

- Sediment laden stormwater from stormwater conveyance over disturbed area
- Fuels, oils, and lubricants from construction vehicles, equipment, and storage
- Solvents, paints, adhesives, etc. from various construction activities
- Transported soils from offsite vehicle tracking
- Construction debris and waste from various construction activities
- Contaminated water from excavation or dewatering pump-out water
- Sanitary waste from onsite restroom facilities
- Trash from various construction activities/receptacles
- Long-term stockpiles of material and waste
- Other: \_\_\_\_\_
- Other: \_\_\_\_\_
- Other: \_\_\_\_\_

**1.11 RECEIVING WATERS:**

Receiving waters must be depicted on the Environmental Layout Sheets in Attachment 1.2 of this SWP3. Include Segment # for receiving waters.

Tributaries	Classified Waterbody

\* Add (\*) for impaired waterbodies with pollutant in ( ).

**1.12 ROLES AND RESPONSIBILITIES: TxDOT**

- Development of plans and specifications
- Submit Notice of Intent (NOI) to TCEQ (≥5 acres)
- Post Construction Site Notice
- Submit NOI/CSN to local MS4
- Perform SWP3 inspections
- Maintain SWP3 records and update to reflect daily operations
- Complete and submit Notice of Termination to TCEQ
- Maintain SWP3 records for 3 years
- Other: \_\_\_\_\_
- Other: \_\_\_\_\_
- Other: \_\_\_\_\_

**1.13 ROLES AND RESPONSIBILITIES: CONTRACTOR**

- Day To Day Operational Control
- Submit Notice of Intent (NOI) to TCEQ (≥5 acres)
- Post Construction Site Notice
- Submit NOI/CSN to local MS4
- Maintain schedule of major construction activities
- Install, maintain and modify BMPs
- Complete and submit Notice of Termination to TCEQ
- Maintain SWP3 records for 3 years
- Other: \_\_\_\_\_
- Other: \_\_\_\_\_
- Other: \_\_\_\_\_

**1.14 LOCAL MUNICIPAL SEPARATE STORM SEWER SYSTEM (MS4) OPERATOR COORDINATION:**

MS4 Entity

**STORMWATER POLLUTION PREVENTION PLAN (SWP3)**



Sheet 1 of 2

FED. RD. DIV. NO.	PROJECT NO.			SHEET NO.
	0916-28-071			64
STATE	STATE DIST.	COUNTY		
TEXAS	CRP	SAN PATRICIO		
CONT.	SECT.	JOB	HIGHWAY NO.	
0916	28	071	PR 25A	

**STORMWATER POLLUTION PREVENTION PLAN (SWP3):**

**2.0 BEST MANAGEMENT PRACTICES (BMPs) AND CONTROLS, INSPECTION, AND MAINTENANCE**

The Contractor shall be the responsible party for implementing the BMPs described herein and for complying with the SWP3 for control of erosion and sedimentation during day-to-day operations. The Contractor shall implement changes to this SWP3 approved by TxDOT within the times specified in this SWP3 or the CGP.

**2.1 EROSION CONTROL AND SOIL STABILIZATION BMPs:**

**T / P**

- Protection of Existing Vegetation
- Vegetated Buffer Zones
- Soil Retention Blankets
- Geotextiles
- Mulching/ Hydromulching
- Soil Surface Treatments
- Temporary Seeding
- Permanent Planting, Sodding or Seeding
- Biodegradable Erosion Control Logs
- Rock Filter Dams/ Rock Check Dams
- Vertical Tracking
- Interceptor Swale
- Riprap
- Diversion Dike
- Temporary Pipe Slope Drain
- Embankment for Erosion Control
- Paved Flumes
- Other: \_\_\_\_\_
- Other: \_\_\_\_\_
- Other: \_\_\_\_\_
- Other: \_\_\_\_\_

**2.2 SEDIMENT CONTROL BMPs:**

**T / P**

- Biodegradable Erosion Control Logs
- Dewatering Controls
- Inlet Protection
- Rock Filter Dams/ Rock Check Dams
- Sandbag Berms
- Sediment Control Fence
- Stabilized Construction Exit
- Floating Turbidity Barrier
- Vegetated Buffer Zones
- Vegetated Filter Strips
- Other: \_\_\_\_\_
- Other: \_\_\_\_\_
- Other: \_\_\_\_\_
- Other: \_\_\_\_\_

Refer to the Environmental Layout Sheets/ SWP3 Layout Sheets located in Attachment 1.2 of this SWP3

Sediment control BMPs requiring design capacity calculations (See SWP3 Attachment 1.3.):

**T / P**

- Sediment Trap
  - Calculated volume runoff from 2-year, 24-hour storm for each acre of disturbed area
  - 3,600 cubic feet of storage per acre drained
- Sedimentation Basin
  - Not required (<10 acres disturbed)
  - Required (>10 acres) and implemented.
    - Calculated volume runoff from 2-year, 24-hour storm for each acre of disturbed area
    - 3,600 cubic feet of storage per acre drained
  - Required (>10 acres), but not feasible due to:
    - Available area/Site geometry
    - Site slope/Drainage patterns
    - Site soils/Geotechnical factors
    - Public safety
    - Other: \_\_\_\_\_

**2.3 PERMANENT CONTROLS:**

(Coordinate post-construction BMPs with appropriate TxDOT maintenance sections.)

BMPs To Be Left In Place Post Construction:

Type	Stationing	
	From	To

Refer to the Environmental Layout Sheets/ SWP3 Layout Sheets located in Attachment 1.2 of this SWP3

**2.4 OFFSITE VEHICLE TRACKING CONTROLS:**

- Excess dirt/mud on road removed daily
- Haul roads dampened for dust control
- Loaded haul trucks to be covered with tarpaulin
- Stabilized construction exit
- Other: \_\_\_\_\_
- Other: \_\_\_\_\_
- Other: \_\_\_\_\_
- Other: \_\_\_\_\_

**2.5 POLLUTION PREVENTION MEASURES:**

- Chemical Management
- Concrete and Materials Waste Management
- Debris and Trash Management
- Dust Control
- Sanitary Facilities
- Other: \_\_\_\_\_
- Other: \_\_\_\_\_
- Other: \_\_\_\_\_
- Other: \_\_\_\_\_

**2.6 VEGETATED BUFFER ZONES:**

Natural vegetated buffers shall be maintained as feasible to protect adjacent surface waters. If vegetated natural buffer zones are not feasible due to site geometry, the appropriate additional sediment control measures have been incorporated into this SWP3.

Type	Stationing	
	From	To

Refer to the Environmental Layout Sheets/ SWP3 Layout Sheets located in Attachment 1.2 of this SWP3

**2.7 ALLOWABLE NON-STORMWATER DISCHARGES:**

- Fire hydrant flushings
- Irrigation drainage
- Pavement washwater (where spills or leaks have not occurred, and detergents are not used)
- Potable water sources
- Springs
- Uncontaminated groundwater
- Water used to wash vehicles or control dust
- Other allowable non-stormwater discharges as allowed by TPDES GP TXR150000.

**2.8 INSPECTIONS:**

All disturbed areas and erosion and sediment control devices shall be inspected at least once every seven (7) days. Inspections shall be performed by TxDOT as indicated on the Field Inspection and Maintenance Report Form 2118 and retained in Attachment 2.5 of this SWP3 .

**2.9 MAINTENANCE:**

Control measures shall be properly installed according to specifications. If it is determined that a BMP or control measure is not operating effectively, maintenance must be accomplished as soon as possible and before the next anticipated rain event, but in no case later than 7 calendar days after being able to access the site. Maintenance shall be performed by the Contractor as indicated on the Field Inspection and Maintenance Report Form 2118 and retained in Attachment 2.5 of this SWP3.

**STORMWATER POLLUTION PREVENTION PLAN (SWP3)**



Sheet 2 of 2

FED. RD. DIV. NO.	PROJECT NO.		SHEET NO.
	0916-28-071		65
STATE	STATE DIST.	COUNTY	
TEXAS	CRP	SAN PATRICIO	
CONT.	SECT.	JOB	HIGHWAY NO.
0916	28	071	PR 25A

DISCLAIMER: The use of this standard is governed by the "Texas Engineering Practice Act". No warranty of any kind is made by TxDOT for any purpose whatsoever. TxDOT assumes no responsibility for the conversion of this standard to other formats or for incorrect results or damages resulting from its use.

DATE: FILE:

**I. STORMWATER POLLUTION PREVENTION-CLEAN WATER ACT SECTION 402**

TPDES TXR 150000: Stormwater Discharge Permit or Construction General Permit required for projects with 1 or more acres disturbed soil. Projects with any disturbed soil must protect for erosion and sedimentation in accordance with Item 506.

List MS4 Operator(s) that may receive discharges from this project. They may need to be notified prior to construction activities.

1.  
2.  
 No Action Required     Required Action

Action No.

- Prevent stormwater pollution by controlling erosion and sedimentation in accordance with TPDES Permit TXR 150000
- Comply with the SW3P and revise when necessary to control pollution or required by the Engineer.
- Post Construction Site Notice (CSN) with SW3P information on or near the site, accessible to the public and TCEQ, EPA or other inspectors.
- When Contractor project specific locations (PSL's) increase disturbed soil area to 5 acres or more, submit NOI to TCEQ and the Engineer.

**II. WORK IN OR NEAR STREAMS, WATERBODIES AND WETLANDS CLEAN WATER ACT SECTIONS 401 AND 404**

USACE Permit required for filling, dredging, excavating or other work in any water bodies, rivers, creeks, streams, wetlands or wet areas.

The Contractor must adhere to all of the terms and conditions associated with the following permit(s):

- No Permit Required
- Nationwide Permit 14 - PCN not Required (less than 1/10th acre waters or wetlands affected)
- Nationwide Permit 14 - PCN Required (1/10 to <1/2 acre, 1/3 in tidal waters)
- Individual 404 Permit Required
- Other Nationwide Permit Required: NWP# \_\_\_\_\_

Required Actions: List waters of the US permit applies to, location in project and check Best Management Practices planned to control erosion, sedimentation and post-project TSS.

- 
- 
- 
- 

The elevation of the ordinary high water marks of any areas requiring work to be performed in the waters of the US requiring the use of a nationwide permit can be found on the Bridge Layouts.

**Best Management Practices:**

<b>Erosion</b>	<b>Sedimentation</b>	<b>Post-Construction TSS</b>
<input type="checkbox"/> Temporary Vegetation	<input checked="" type="checkbox"/> Silt Fence	<input type="checkbox"/> Vegetative Filter Strips
<input type="checkbox"/> Blankets/Matting	<input type="checkbox"/> Rock Berm	<input type="checkbox"/> Retention/Irrigation Systems
<input type="checkbox"/> Mulch	<input type="checkbox"/> Triangular Filter Dike	<input type="checkbox"/> Extended Detention Basin
<input type="checkbox"/> Sodding	<input type="checkbox"/> Sand Bag Berm	<input type="checkbox"/> Constructed Wetlands
<input type="checkbox"/> Interceptor Swale	<input type="checkbox"/> Straw Bale Dike	<input type="checkbox"/> Wet Basin
<input type="checkbox"/> Diversion Dike	<input type="checkbox"/> Brush Berms	<input type="checkbox"/> Erosion Control Compost
<input type="checkbox"/> Erosion Control Compost	<input type="checkbox"/> Erosion Control Compost	<input type="checkbox"/> Mulch Filter Berm and Socks
<input type="checkbox"/> Mulch Filter Berm and Socks	<input type="checkbox"/> Mulch Filter Berm and Socks	<input type="checkbox"/> Compost Filter Berm and Socks
<input type="checkbox"/> Compost Filter Berm and Socks	<input type="checkbox"/> Compost Filter Berm and Socks	<input type="checkbox"/> Vegetation Lined Ditches
	<input type="checkbox"/> Stone Outlet Sediment Traps	<input type="checkbox"/> Sand Filter Systems
	<input type="checkbox"/> Sediment Basins	<input type="checkbox"/> Grassy Swales

**III. CULTURAL RESOURCES**

Refer to TxDOT Standard Specifications in the event historical issues or archeological artifacts are found during construction. Upon discovery of archeological artifacts (bones, burnt rock, flint, pottery, etc.) cease work in the immediate area and contact the Engineer immediately.

- No Action Required     Required Action

Action No.

- 
- 
- 
- 

**IV. VEGETATION RESOURCES**

Preserve native vegetation to the extent practical. Contractor must adhere to Construction Specification Requirements Specs 162, 164, 192, 193, 506, 730, 751, 752 in order to comply with requirements for invasive species, beneficial landscaping, and tree/brush removal commitments.

- No Action Required     Required Action

Action No.

- 
- 
- 
- 

**V. FEDERAL LISTED, PROPOSED THREATENED, ENDANGERED SPECIES, CRITICAL HABITAT, STATE LISTED SPECIES, CANDIDATE SPECIES AND MIGRATORY BIRDS.**

- No Action Required     Required Action

Action No.

- 
- 
- 
- 

If any of the listed species are observed, cease work in the immediate area, do not disturb species or habitat and contact the Engineer immediately. The work may not remove active nests from bridges and other structures during nesting season of the birds associated with the nests. If caves or sinkholes are discovered, cease work in the immediate area, and contact the Engineer immediately.

**LIST OF ABBREVIATIONS**

BMP: Best Management Practice	SPCC: Spill Prevention Control and Countermeasure
CGP: Construction General Permit	SW3P: Storm Water Pollution Prevention Plan
DSHS: Texas Department of State Health Services	PCN: Pre-Construction Notification
FHWA: Federal Highway Administration	PSL: Project Specific Location
MOA: Memorandum of Agreement	TCEQ: Texas Commission on Environmental Quality
MOU: Memorandum of Understanding	TPDES: Texas Pollutant Discharge Elimination System
MS4: Municipal Separate Stormwater Sewer System	TPWD: Texas Parks and Wildlife Department
MBTA: Migratory Bird Treaty Act	TxDOT: Texas Department of Transportation
NOT: Notice of Termination	T&E: Threatened and Endangered Species
NWP: Nationwide Permit	USACE: U.S. Army Corps of Engineers
NOI: Notice of Intent	USFWS: U.S. Fish and Wildlife Service

**VI. HAZARDOUS MATERIALS OR CONTAMINATION ISSUES**

General (applies to all projects):

Comply with the Hazard Communication Act (the Act) for personnel who will be working with hazardous materials by conducting safety meetings prior to beginning construction and making workers aware of potential hazards in the workplace. Ensure that all workers are provided with personal protective equipment appropriate for any hazardous materials used. Obtain and keep on-site Material Safety Data Sheets (MSDS) for all hazardous products used on the project, which may include, but are not limited to the following categories: Paints, acids, solvents, asphalt products, chemical additives, fuels and concrete curing compounds or additives. Provide protected storage, off bare ground and covered, for products which may be hazardous. Maintain product labelling as required by the Act. Maintain an adequate supply of on-site spill response materials, as indicated in the MSDS. In the event of a spill, take actions to mitigate the spill as indicated in the MSDS, in accordance with safe work practices, and contact the District Spill Coordinator immediately. The Contractor shall be responsible for the proper containment and cleanup of all product spills.

Contact the Engineer if any of the following are detected:

- \* Dead or distressed vegetation (not identified as normal)
- \* Trash piles, drums, canister, barrels, etc.
- \* Undesirable smells or odors
- \* Evidence of leaching or seepage of substances

Does the project involve any bridge class structure rehabilitation or replacements (bridge class structures not including box culverts)?

- Yes     No

If "No", then no further action is required.

If "Yes", then TxDOT is responsible for completing asbestos assessment/inspection.

Are the results of the asbestos inspection positive (is asbestos present)?

- Yes     No

If "Yes", then TxDOT must retain a DSHS licensed asbestos consultant to assist with the notification, develop abatement/mitigation procedures, and perform management activities as necessary. The notification form to DSHS must be postmarked at least 15 working days prior to scheduled demolition.

If "No", then TxDOT is still required to notify DSHS 15 working days prior to any scheduled demolition.

In either case, the Contractor is responsible for providing the date(s) for abatement activities and/or demolition with careful coordination between the Engineer and asbestos consultant in order to minimize construction delays and subsequent claims.

Any other evidence indicating possible hazardous materials or contamination discovered on site. Hazardous Materials or Contamination Issues Specific to this Project:

- No Action Required     Required Action

Action No.

- 
- 
- 

**VII. OTHER ENVIRONMENTAL ISSUES**

(includes regional issues such as Edwards Aquifer District, etc.)

- No Action Required     Required Action

Action No.

- 
- 
- 

 Texas Department of Transportation		<i>Design Division Standard</i>	
<b>ENVIRONMENTAL PERMITS, ISSUES AND COMMITMENTS EPIC</b>			
FILE: epic.dgn	DN: TxDOT	CK: RG	DW: VP
©TxDOT: February 2015	CONT	SECT	JOB
12-12-2011 (DS) REVISIONS	0916	28	071
05-07-14 ADDED NOTE SECTION IV.	DIST	COUNTY	SHEET NO.
01-23-2015 SECTION I (CHANGED ITEM 1122 TO ITEM 506, ADDED GRASSY SWALES.	CRP	SAN PATRICIO	66

10/18/2023  
 projectwiseonline.com  
 TxDOT for any purpose whatsoever. No warranty of any kind is made by TxDOT for the conversion of this standard to other formats or for incorrect results or damages resulting from its use. TxDOT assumes no responsibility for the conversion of this standard to other formats or for incorrect results or damages resulting from its use. CRP/Design Projects/091628071/4 - Design/Plan Set/13. Standards/EC(1)-16.dgn

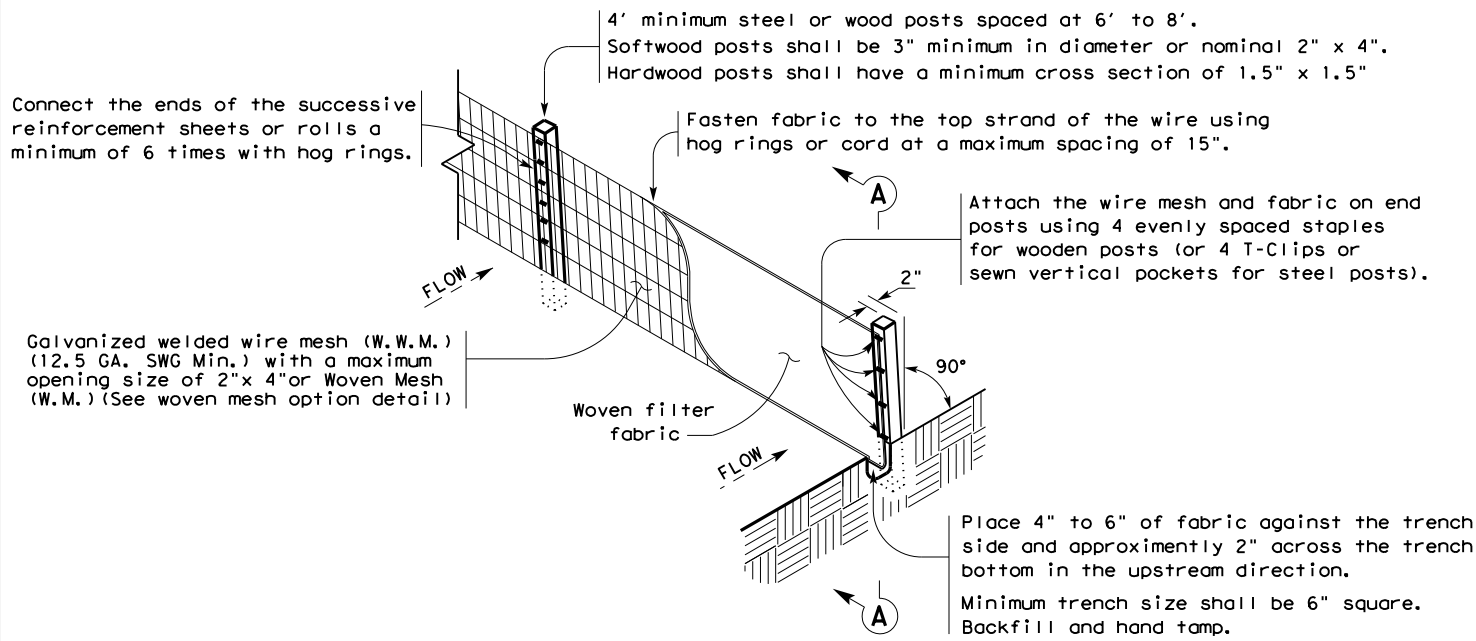

**TEMPORARY SEDIMENT CONTROL FENCE**

SCF

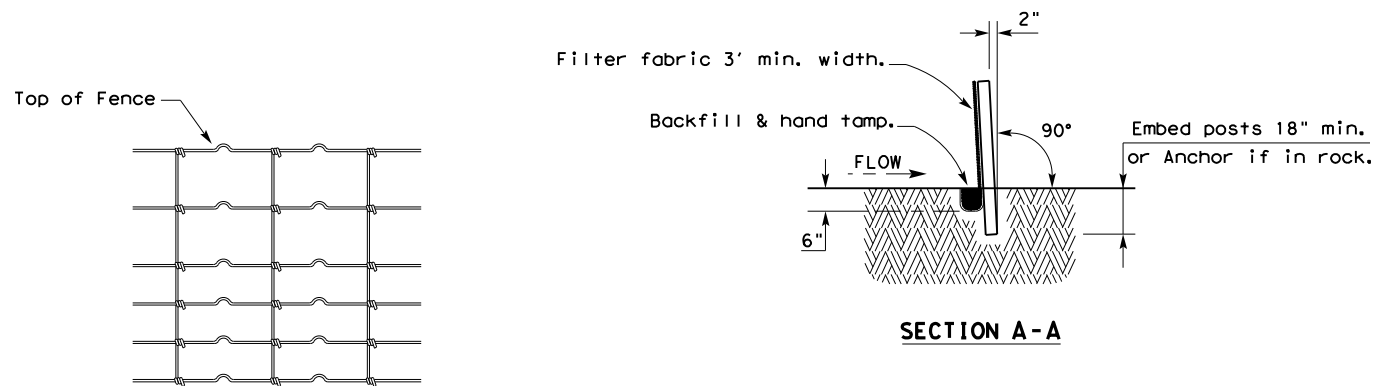

**HINGE JOINT KNOT WOVEN MESH (OPTION) DETAIL**

Galvanized hinge joint knot woven mesh (12.5 GA. SWG Min.) requires a minimum of five horizontal wires spaced at a maximum of 12 inches apart and all vertical wires spaced at a maximum of 12 inches apart.

**SEDIMENT CONTROL FENCE USAGE GUIDELINES**

A sediment control fence may be constructed near the downstream perimeter of a disturbed area along a contour to intercept sediment from overland runoff. A 2 year storm frequency may be used to calculate the flow rate to be filtered.

Sediment control fence should be sized to filter a maximum flow through rate of 100 GPM/FT<sup>2</sup>. Sediment control fence is not recommended to control erosion from a drainage area larger than 2 acres.

**LEGEND**

Sediment Control Fence

SCF

**GENERAL NOTES**

1. Vertical tracking is required on projects where soil distributing activities have occurred unless otherwise approved.
2. Perform vertical tracking on slopes to temporarily stabilize soil.
3. Provide equipment with a track undercarriage capable of producing linear soil impressions measuring a minimum of 12" in length by 2" to 4" in width by 1/2" to 2" in depth.
4. Do not exceed 12" between track impressions.
5. Install continuous linear track impressions where the minimum 12" length impressions are perpendicular to the slope or direction of water flow.

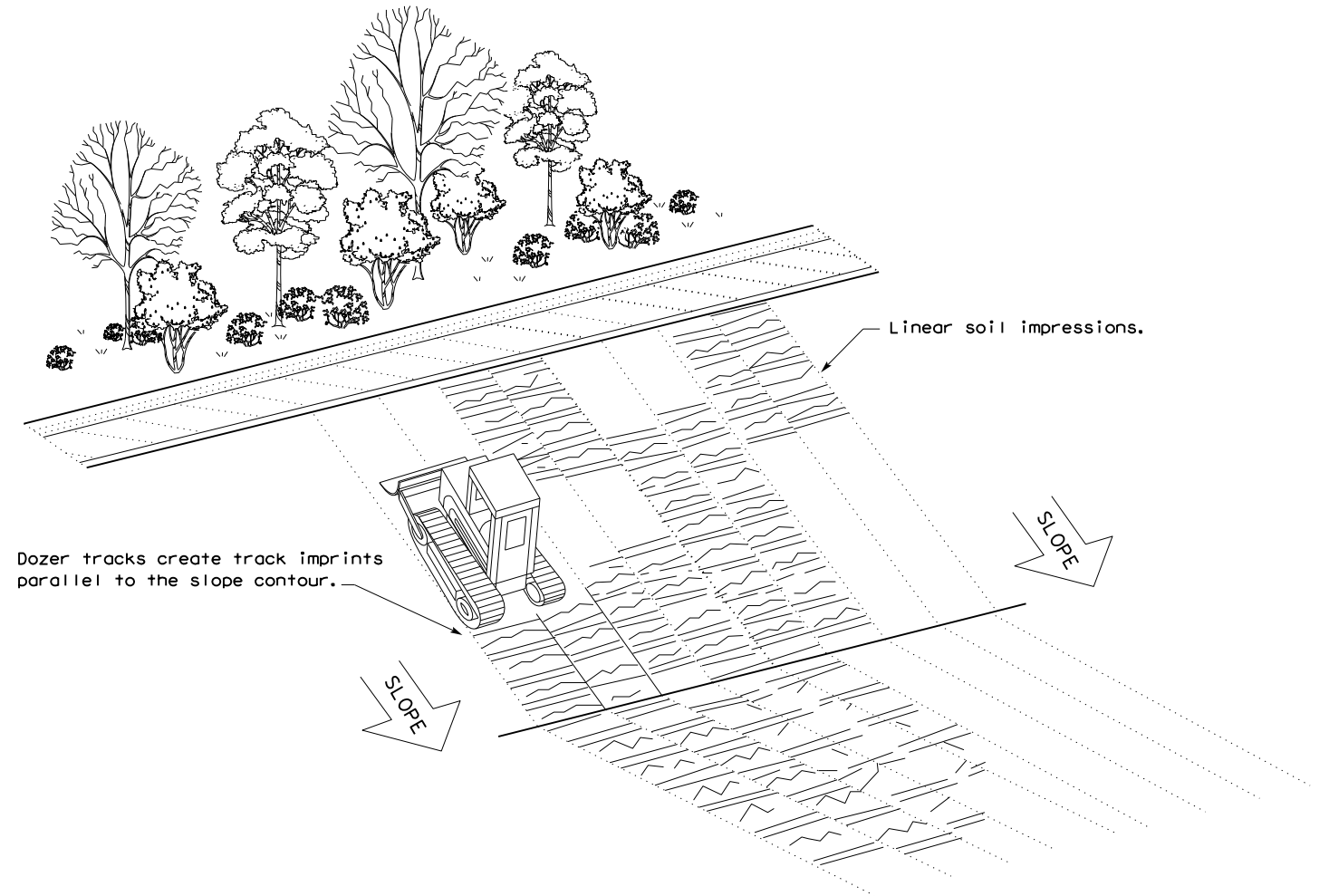

**VERTICAL TRACKING**

				Design Division Standard	
<b>TEMPORARY EROSION, SEDIMENT AND WATER POLLUTION CONTROL MEASURES FENCE &amp; VERTICAL TRACKING EC(1)-16</b>					
FILE: ec116	DN: TxDOT	CK: KM	DW: VP	DN/CK: LS	
© TxDOT: JULY 2016	CONT	SECT	JOB	HIGHWAY	
REVISIONS	0916 28		071	PR 25A	
	DIST	COUNTY		SHEET NO.	
	CRP	SAN PATRICIO		67	



DISCLAIMER: The use of this standard is governed by the "Texas Engineering Practice Act". No warranty of any kind is made by TxDOT for any purpose whatsoever. TxDOT assumes no responsibility for the conversion of this standard to other formats or for incorrect results or damages resulting from its use.

DATE: 1/13/2023  
 FILE: pwt//twdot.projectwiseonline.com/TxDOT4/Documents/16 - CRP/Design Projects/091628071/4 - Design/Plan Set/13. Standards/EC(9) -16.dgn

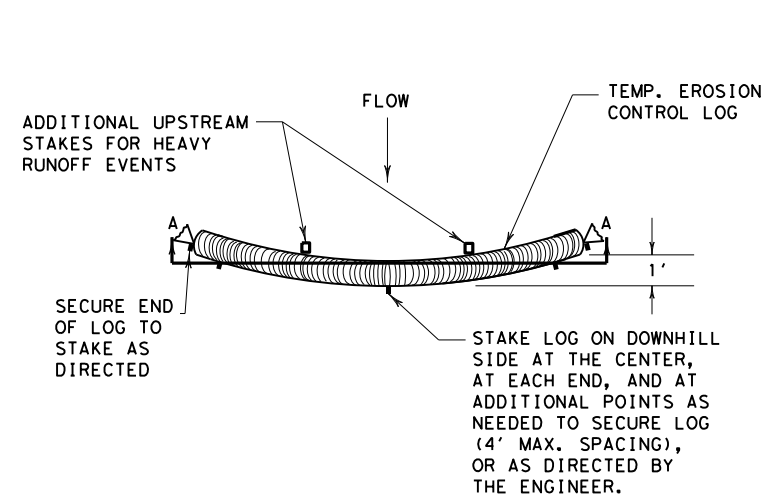

PLAN VIEW

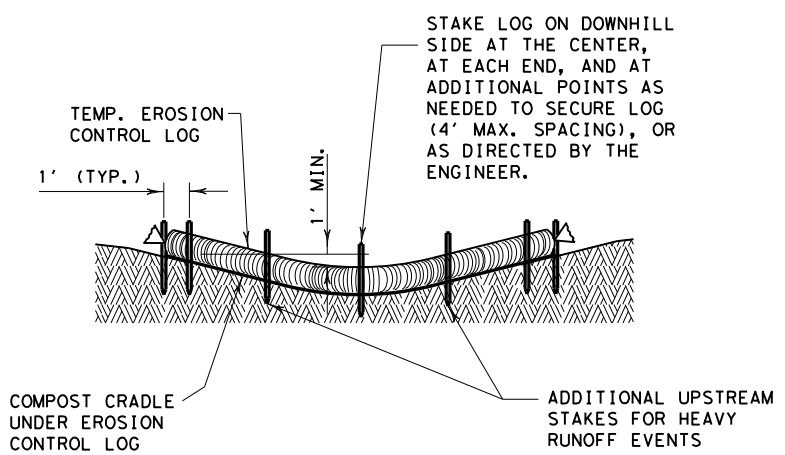

SECTION A-A  
EROSION CONTROL LOG DAM

CL-D

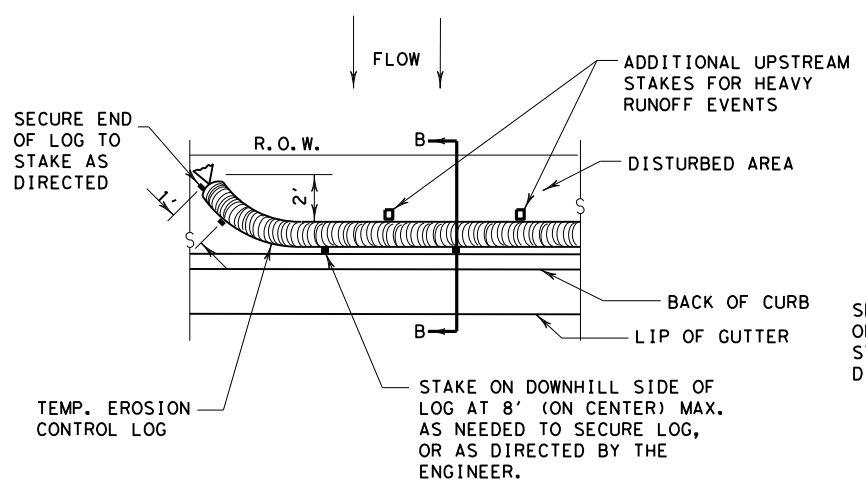

PLAN VIEW

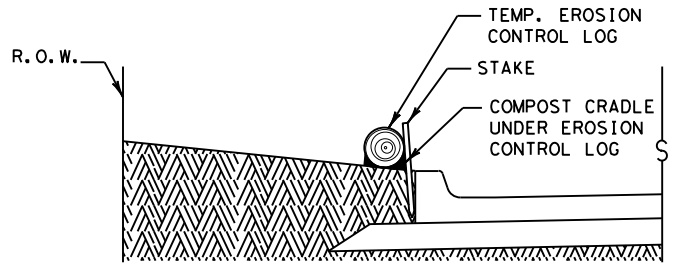

SECTION B-B  
EROSION CONTROL LOG AT BACK OF CURB

CL-BOC

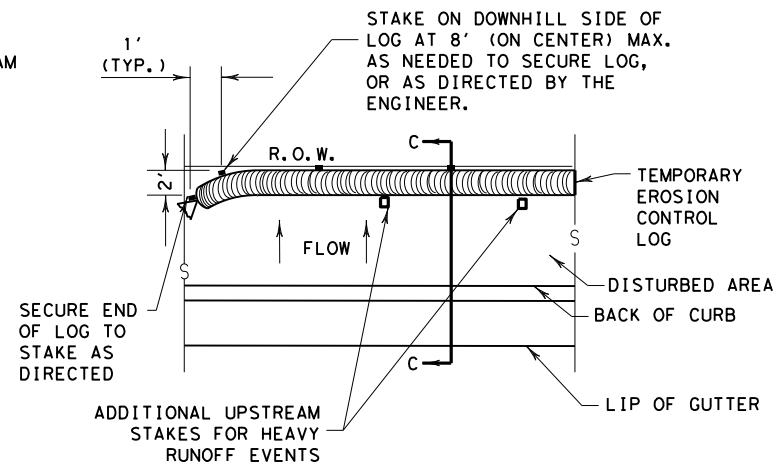

PLAN VIEW

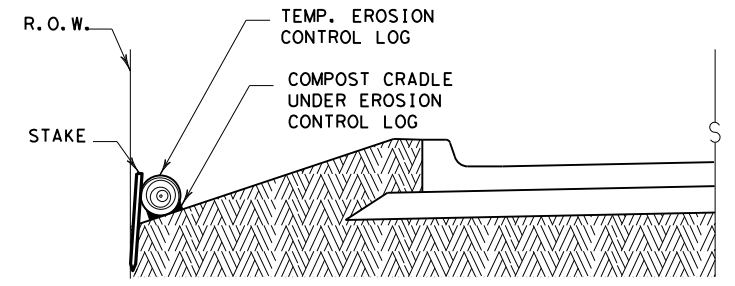

SECTION C-C

EROSION CONTROL LOG AT EDGE OF RIGHT-OF-WAY

CL-ROW

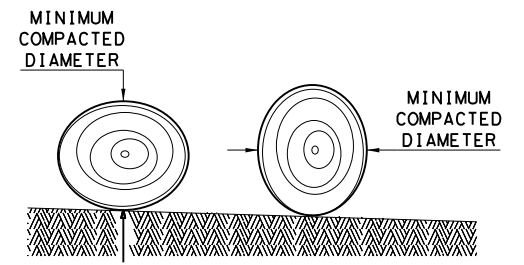

DIAMETER MEASUREMENTS OF EROSION CONTROL LOGS SPECIFIED IN PLANS

- LEGEND**
- CL-D EROSION CONTROL LOG DAM
  - CL-BOC EROSION CONTROL LOG AT BACK OF CURB
  - CL-ROW EROSION CONTROL LOG AT EDGE OF RIGHT-OF-WAY
  - CL-SST EROSION CONTROL LOGS ON SLOPES STAKE AND TRENCHING ANCHORING
  - CL-SSL EROSION CONTROL LOGS ON SLOPES STAKE AND LASHING ANCHORING
  - CL-DI EROSION CONTROL LOG AT DROP INLET
  - CL-CI EROSION CONTROL LOG AT CURB INLET
  - CL-GI EROSION CONTROL LOG AT CURB & GRATE INLET

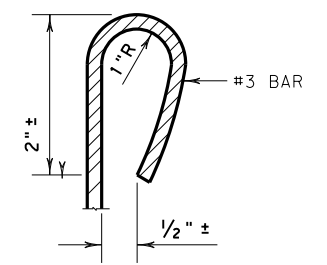

REBAR STAKE DETAIL

**SEDIMENT BASIN & TRAP USAGE GUIDELINES**

An erosion control log sediment trap may be used to filter sediment out of runoff draining from an unstabilized area.

**Log Traps:** The drainage area for a sediment trap should not exceed 5 acres. The trap capacity should be 1800 CF/Acre (0.5" over the drainage area).

Control logs should be placed in the following locations:

1. Within drainage ditches spaced as needed or min. 500' on center
2. Immediately preceding ditch inlets or drain inlets
3. Just before the drainage enters a water course
4. Just before the drainage leaves the right of way
5. Just before the drainage leaves the construction limits where drainage flows away from the project.

The logs should be cleaned when the sediment has accumulated to a depth of 1/2 the log diameter.

Cleaning and removal of accumulated sediment deposits is incidental and will not be paid for separately.

**GENERAL NOTES:**

1. EROSION CONTROL LOGS SHALL BE INSTALLED IN ACCORDANCE WITH MANUFACTURER'S RECOMMENDATIONS, OR AS DIRECTED BY THE ENGINEER.
2. LENGTHS OF EROSION CONTROL LOGS SHALL BE IN ACCORDANCE WITH MANUFACTURER'S RECOMMENDATIONS AND AS REQUIRED FOR THE PURPOSE INTENDED.
3. UNLESS OTHERWISE DIRECTED, USE BIODEGRADABLE OR PHOTODEGRADABLE CONTAINMENT MESH ONLY WHERE LOG WILL REMAIN IN PLACE AS PART OF A VEGETATIVE SYSTEM. FOR TEMPORARY INSTALLATIONS, USE RECYCLABLE CONTAINMENT MESH.
4. FILL LOGS WITH SUFFICIENT FILTER MATERIAL TO ACHIEVE THE MINIMUM COMPACTED DIAMETER SPECIFIED IN THE PLANS WITHOUT EXCESSIVE DEFORMATION.
5. STAKES SHALL BE 2" X 2" WOOD OR #3 REBAR, 2'-4' LONG, EMBEDDED SUCH THAT 2" PROTRUDES ABOVE LOG, OR AS DIRECTED BY THE ENGINEER.
6. DO NOT PLACE STAKES THROUGH CONTAINMENT MESH.
7. COMPOST CRADLE MATERIAL IS INCIDENTAL & WILL NOT BE PAID FOR SEPARATELY.
8. SANDBAGS USED AS ANCHORS SHALL BE PLACED ON TOP OF LOGS & SHALL BE OF SUFFICIENT SIZE TO HOLD LOGS IN PLACE.
9. TURN THE ENDS OF EACH ROW OF LOGS UPSLOPE TO PREVENT RUNOFF FROM FLOWING AROUND THE LOG.
10. FOR HEAVY RUNOFF EVENTS, ADDITIONAL UPSTREAM STAKES MAY BE NECESSARY TO KEEP LOG FROM FOLDING IN ON ITSELF.

SHEET 1 OF 3

		<i>Design Division Standard</i>	
<b>TEMPORARY EROSION, SEDIMENT AND WATER POLLUTION CONTROL MEASURES</b> <b>EROSION CONTROL LOG</b> <b>EC (9) - 16</b>			
FILE: ec916	DN: TxDOT	CK: KM	DW: LS/PT
© TxDOT: JULY 2016	CONT	SECT	JOB
REVISIONS	0916 28	071	PR 25A
	DIST	COUNTY	SHEET NO.
	CRP	SAN PATRICIO	68

DISCLAIMER: The use of this standard is governed by the "Texas Engineering Practice Act". No warranty of any kind is made by TxDOT for any purpose whatsoever. TxDOT assumes no responsibility for the conversion of this standard to other formats or for incorrect results or damages resulting from its use.

DATE: 1/13/2023  
 FILE: p:\twdot\projectwiseonline.com\txdot4\Documents\16 - CRP\Design Projects\091628071\4 - Design\Plan Set\13. Standards\EC(9) -16.dgn

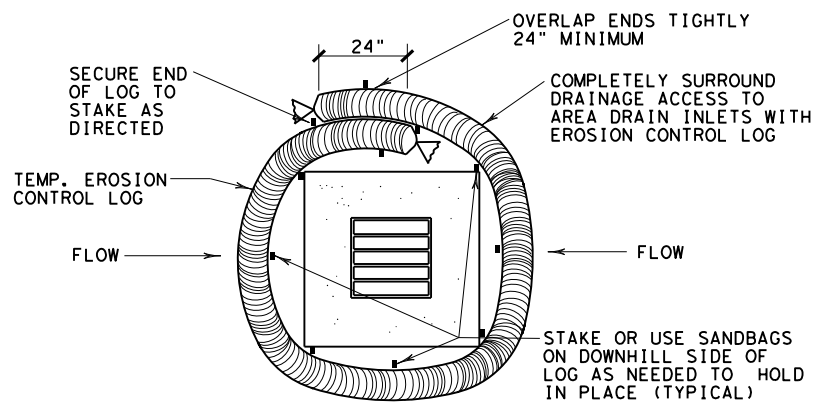

**EROSION CONTROL LOG AT DROP INLET**

CL-DI

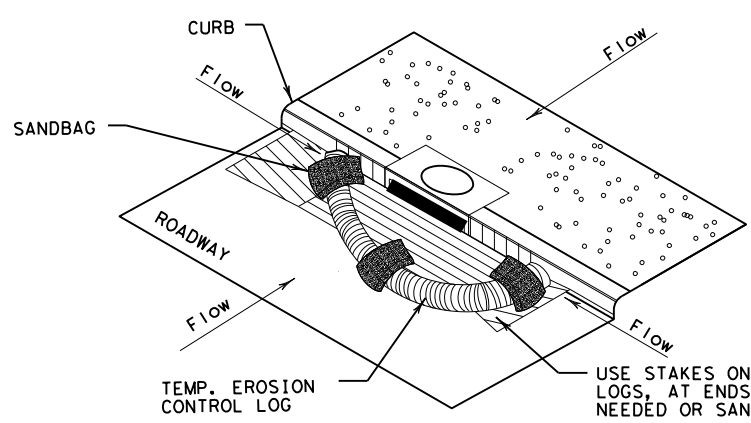

**EROSION CONTROL LOG AT CURB INLET**

CL-CI

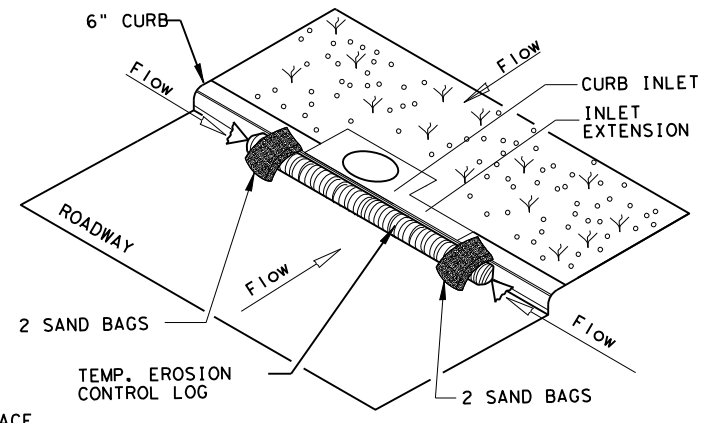

**EROSION CONTROL LOG AT CURB INLET**

CL-CI

NOTE:  
 EROSION CONTROL LOGS USED AT CURB INLETS SHOULD ONLY BE USED IF THEY WILL NOT IMPEDE TRAFFIC OR FLOOD THE ROADWAY OR WHEN THE STORM SEWER SYSTEM IS NOT FULLY FUNCTIONAL.

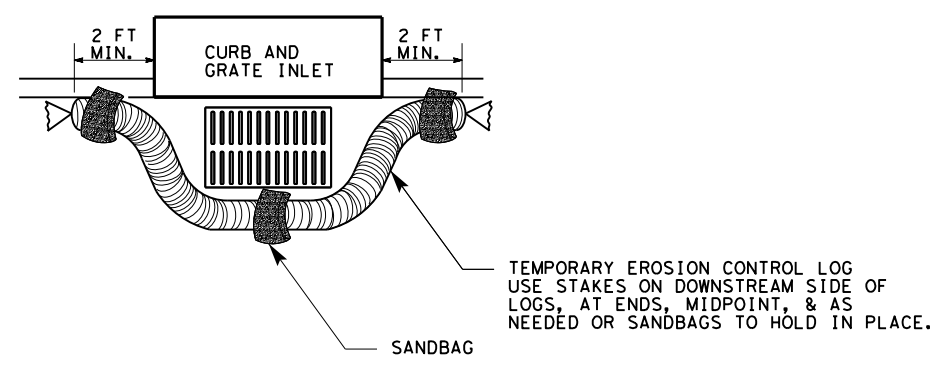

**EROSION CONTROL LOG AT CURB & GRADE INLET**

CL-GI

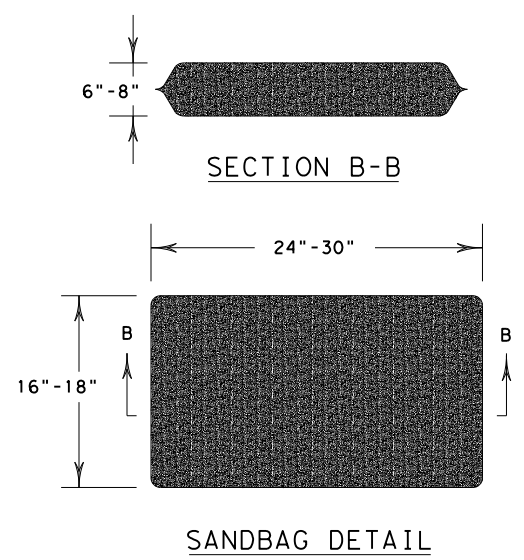

SHEET 3 OF 3

		<i>Design Division Standard</i>	
<b>TEMPORARY EROSION, SEDIMENT AND WATER POLLUTION CONTROL MEASURES</b> <b>EROSION CONTROL LOG</b> <b>EC (9) - 16</b>			
FILE: ec916	DN: TxDOT	CK: KM	DW: LS/PT
© TxDOT: JULY 2016	CONT	SECT	JOB
REVISIONS	0916 28	071	PR 25A
DIST	COUNTY	SHEET NO.	
CRP	SAN PATRICIO	70	

DISCLAIMER: The use of this standard is governed by the "Texas Engineering Practice Act". No warranty of any kind is made by TxDOT for any purpose whatsoever. TxDOT assumes no responsibility for the conversion of this standard to other formats or for incorrect results or damages resulting from its use.

DATE: 1/13/2023  
 FILE: pw://txdot.projectwiseonline.com:txdot4/Documents/16 - CRP/Design Projects/091628071/4 - Design/Plan Set/13. Standards/EC(9) - 16.dgn

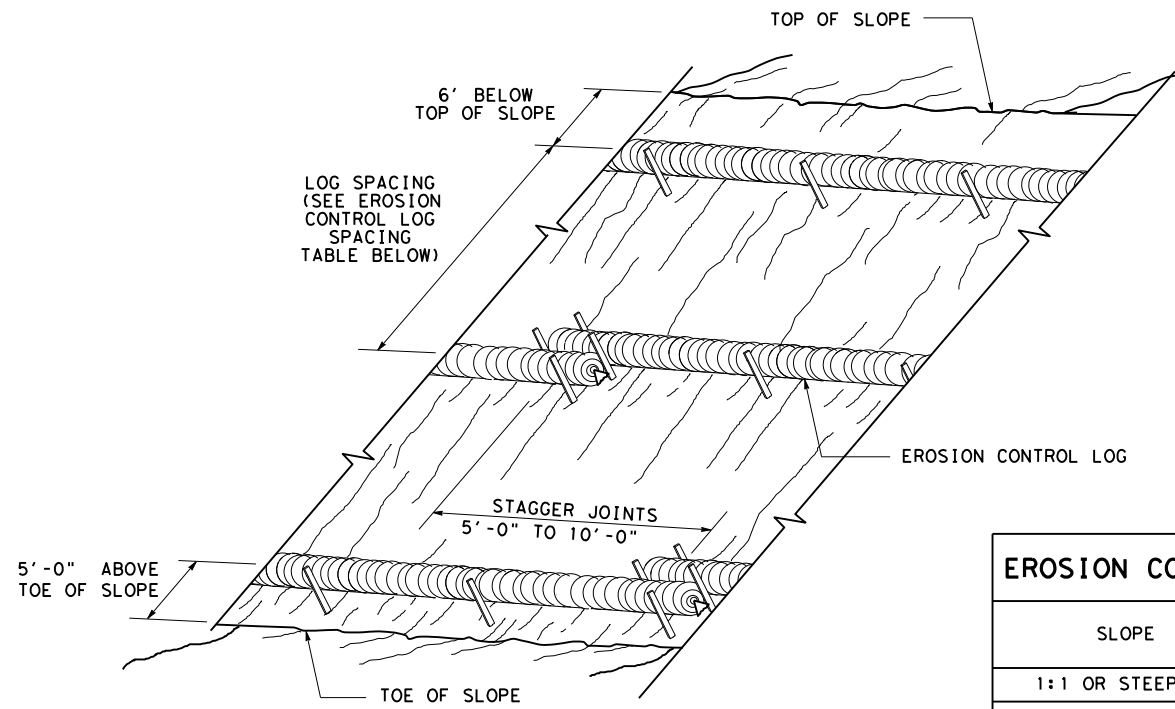

**EROSION CONTROL LOGS ON SLOPES  
 STAKE AND TRENCHING ANCHORING**

CL-SST

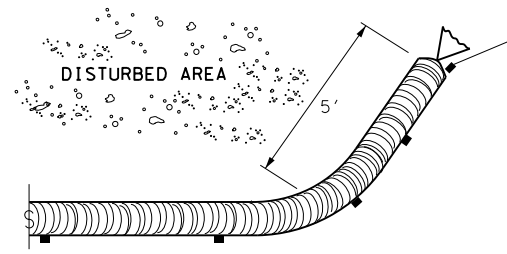

**END SECTION RAP DETAIL**

SLOPE	LOG DIAMETER			
	6"	8"	12"	18"
1:1 OR STEEPER	5'	10'	15'	20'
2:1	10'	20'	30'	40'
3:1	15'	30'	45'	60'
4:1 OR FLATTER	20'	40'	60'	80'

\* ADJUSTMENTS CAN BE MADE FOR SOIL TYPE:  
 SOFT, LOAMY SOILS-ADJUST ROWS CLOSER TOGETHER;  
 HARD, ROCKY SOILS- ADJUST ROWS FARTHER APART

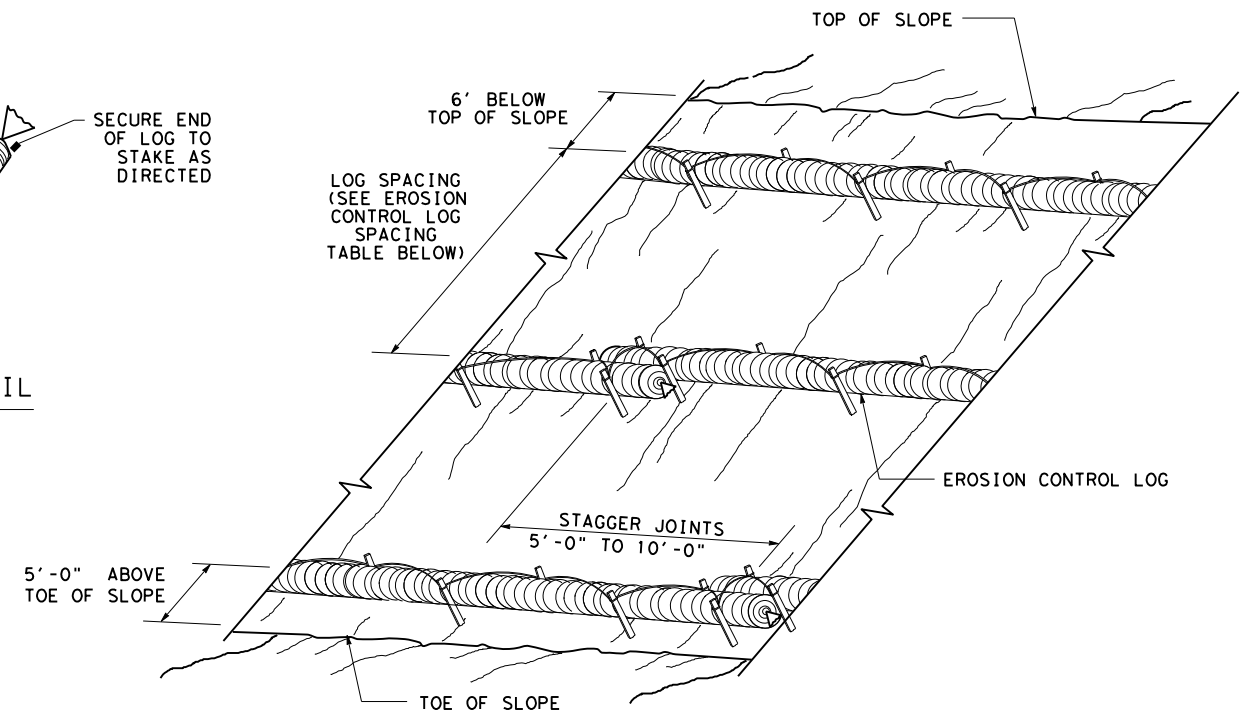

**EROSION CONTROL LOGS ON SLOPES  
 STAKE AND LASHING ANCHORING**

CL-SSL

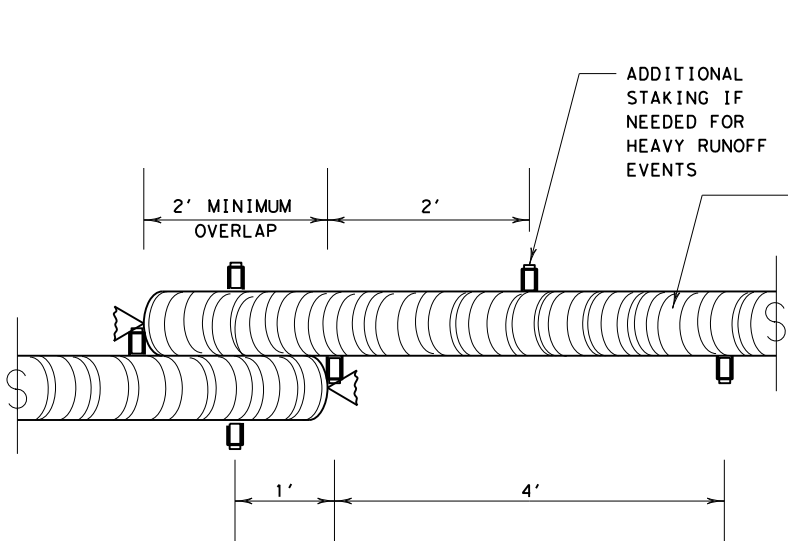

**STAKE AND TRENCHING ANCHORING DETAIL**

CL-SST

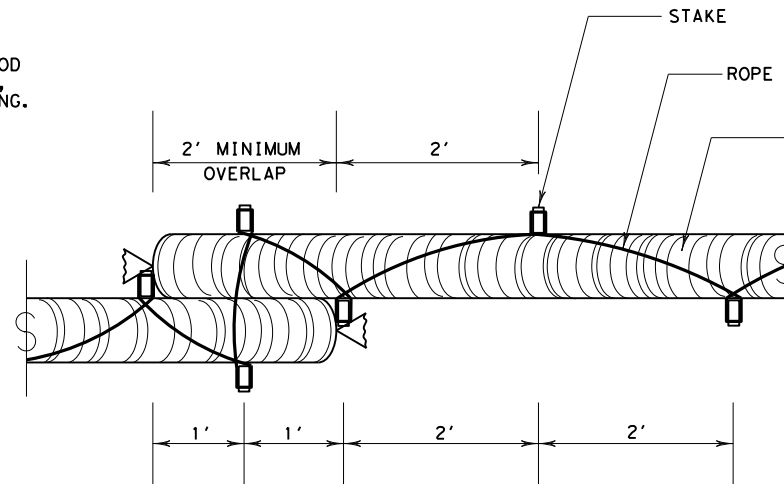
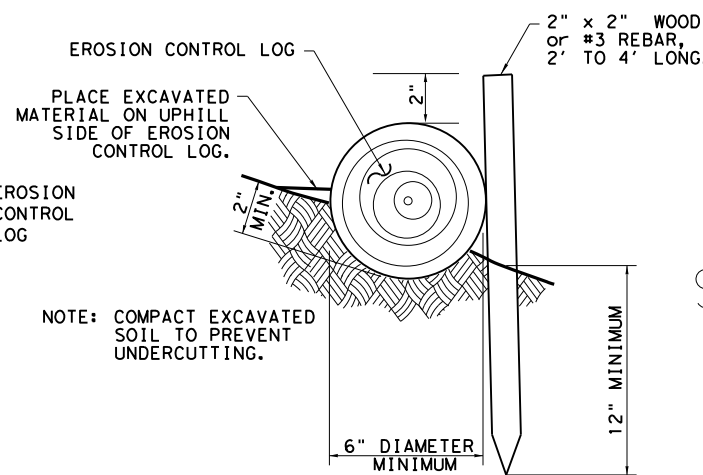

**STAKE AND LASHING ANCHORING DETAIL**

CL-SSL

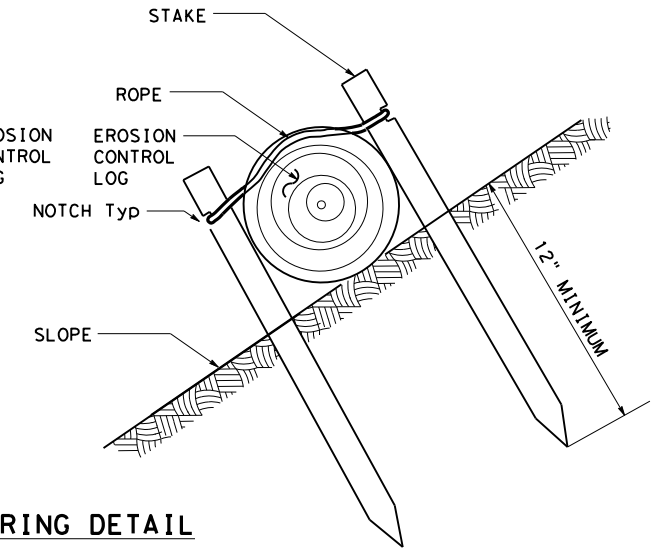

LOG DIAMETER	DEPTH
6"	2"
8"	3"
12"	4"
18"	5"

**TRENCH DEPTH TABLE**

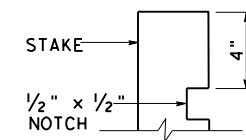

**STAKE NOTCH DETAIL**

SHEET 2 OF 3

		Design Division Standard	
<b>TEMPORARY EROSION,          SEDIMENT AND WATER          POLLUTION CONTROL MEASURES          EROSION CONTROL LOG          EC(9) - 16</b>			
FILE: ec116	DN: TxDOT	CK: KM	DW: LS/PT
© TxDOT: JULY 2016	CONT	SECT	JOB
REVISIONS	0916 28	071	PR 25A
DIST	COUNTY	SHEET NO.	
CRP	SAN PATRICIO	69	