

INDEX OF SHEETS

SHEET NO.	DESCRIPTION
1	TITLE SHEET
2	SUPPLEMENTAL INDEX OF SHEETS

**STATE OF TEXAS
DEPARTMENT OF TRANSPORTATION**

**PLANS OF PROPOSED
STATE HIGHWAY IMPROVEMENT**

PROJECT NO. STP 2022(812)HES
**MARTIN LUTHER KING JR BOULEVARD
SMITH COUNTY**

NET LENGTH OF PROJECT= 2,470.00 FT.= 0.468 MI.

LIMITS: FROM PALACE AVE, TO BROADWAY AVE

FOR THE CONSTRUCTION OF SAFETY IMPROVEMENTS CONSISTING OF
PEDESTRIAN IMPROVEMENTS, VEHICLE DETECTION EQUIPMENT,
AND WIRELESS COMMUNICATION EQUIPMENT

PROJECT NO.			
STP 2022(812)HES			
CONT	SECT	JOB	HIGHWAY
0910	16	165	MLK JR
DIST	COUNTY		SHEET NO.
TYL	SMITH		1

FUNCTIONAL CLASSIFICATION = MINOR ARTERIAL
POSTED SPEED = 40 MPH
A.D.T. (2018) = 8,986

FINAL PLANS

DATE CONTRACT LETTING: _____
DATE CONTRACTOR BEGAN WORK: _____
DATE WORK COMPLETED & ACCEPTED: _____
CONTRACTOR: _____
USED ____ OF ____ ALLOTTED DAYS _____
FINAL CONTRACT COST : \$ _____

FINAL AS BUILT PLANS

THE CONSTRUCTION WAS PERFORMED UNDER MY SUPERVISION
IN ACCORDANCE WITH THE PLANS AND CONTRACT

DATE _____

AREA ENGINEER _____



PLANS PREPARED BY:

Kimley»Horn

TBPE FIRM F-928

13455 NOEL ROAD
TWO GALLERIA OFFICE TOWER, SUITE 700
DALLAS, TEXAS 75240
PH (972) 770-1300
CONTACT: HIRON FERNANDO, P.E.

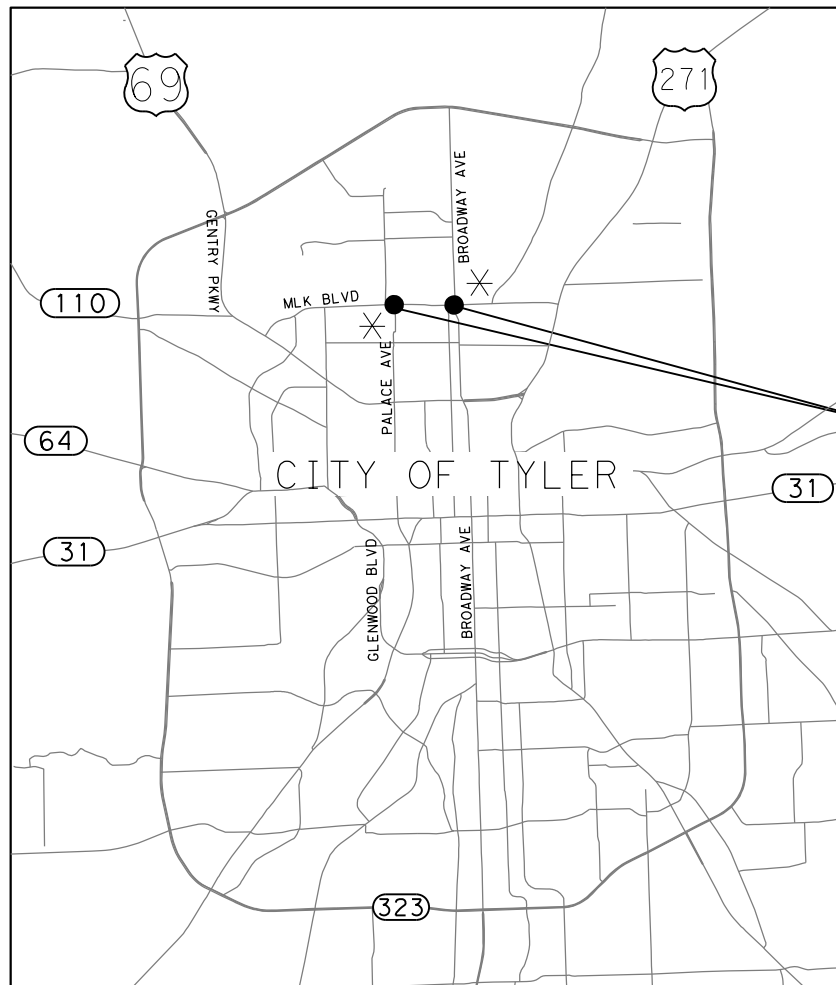

CSJ: 0910-16-165
MLK BLVD AT PALACE AVE
MLK BLVD AT BROADWAY AVE

* SIGN IN ACCORDANCE WITH THE
STANDARD BC SHEETS AND PART 6
OF THE TEXAS MANUAL ON UNIFORM
TRAFFIC CONTROL DEVICES.

EXCEPTIONS: NONE
EQUATIONS: NONE
RAILROAD CROSSINGS: NONE

SPECIFICATIONS ADOPTED BY THE TEXAS DEPARTMENT OF TRANSPORTATION,
NOVEMBER 1, 2014 AND SPECIFICATION ITEMS LISTED AND DATED AS FOLLOWS,
SHALL GOVERN ON THIS PROJECT: REQUIRED CONTRACT PROVISIONS FOR ALL
FEDERAL-AID CONSTRUCTION CONTRACTS (FORM FHWA 1273, MAY 1, 2012)



RECOMMENDED FOR LETTING: 5/30/2022

DocuSigned by:

Juanita Daniels-West

DIRECTOR OF TRANSPORTATION OPERATIONS

SUBMITTED FOR LETTING: 5/31/2022

DocuSigned by:

Rolando Mendez

DISTRICT DESIGN ENGINEER

APPROVED FOR LETTING: 5/31/2022

DocuSigned by:

Hiron M. Fernando

DISTRICT ENGINEER

GENERAL

SHEET NO.	DESCRIPTION
1	TITLE SHEET
2	SUPPLEMENTAL INDEX OF SHEETS
3, 3A-3E	GENERAL NOTES
4	CITY OF TYLER TRAFFIC SIGNAL GENERAL NOTES
5, 5A	ESTIMATE AND QUANTITY SHEET
6, 6A	SUMMARY OF QUANTITIES

TRAFFIC CONTROL PLAN

SHEET NO.	DESCRIPTION
7	CONSTRUCTION SEQUENCE

SHEET NO.	STANDARDS
8 - 19	*BC(1)-21 THRU BC(12)-21
20	*TCP (1-3) - 18
21 - 22	*TCP (2-1)-18, TCP (2-2)-18
23	*TCP (2-4)-18
24 - 25	*WZ (BTS-1)-13, WZ (BTS-2)-13

TRAFFIC ITEMS

SHEET NO.	DESCRIPTION
MLK JR. BOULEVARD AT PALACE AVENUE	
26	PROPOSED CONDITIONS
MLK JR. BOULEVARD AT BROADWAY AVENUE	
27	EXISTING CONDITIONS AND REMOVALS
28	PROPOSED CONDITIONS
29 - 30	PROPOSED QUANTITIES
31	PROPOSED PAVEMENT MARKINGS AND PEDESTRIAN RAMPS
32	PEDESTRIAN SIGNAL AND DETECTOR INSTALLATION DETAILS
33	SIDEWALKS DETAILS

SHEET NO.	STANDARDS
34	*CCCG-21
35 - 38	*PED-18
39 - 45	*ED(1)-14, ED(3)-14 THRU ED(6)-14, ED(8)-14, ED(9)-14
46 - 48	*PM(1)-20 THRU PM(3)-20
49	*PM(4)-22 (MOD)
50	*SMD(GEN)-08
51	*SMD(SLIP-1)-08
52	*SMD(SLIP-2)-08
53	*SMD(SLIP-3)-08
54 - 55	*TSR(3)-13 THRU TSR(4)-13
56	*TS-BP-20
57	*TS-FD-12

ENVIRONMENTAL ISSUES

SHEET NO.	DESCRIPTION
58	STORMWATER POLLUTION PREVENTION PLAN (SW3P)
59	ENVIRONMENTAL PERMITS, ISSUES AND COMMITMENTS (EPIC)

SHEET NO.	STANDARDS
60 - 62	*EC(9)-16

* THE STANDARD SHEETS SPECIFICALLY IDENTIFIED ABOVE HAVE BEEN SELECTED BY ME OR UNDER MY RESPONSIBLE SUPERVISION AS BEING APPLICABLE TO THIS PROJECT.

Hiron M. Fernando

Signature

&

5/13/2022

Date

5/13/2022



Kimley»Horn F-928
 13455 Noel Road
 Two Galleria Office Tower, Suite 700
 Dallas, Texas 75240
 Tel. No. (972) 770-1300
 Fax No. (972) 239-3820



Texas Department of Transportation
 © 2022

TRAFFIC SAFETY IMPROVEMENTS

SUPPLEMENTAL INDEX OF SHEETS

DESIGN	FED. RD. DIV. NO.	FEDERAL AID PROJECT NO.	HIGHWAY NO.
HMF	6	(SEE TITLE SHEET)	CS
CHECK	STATE	DISTRICT	COUNTY
ASA	TEXAS	TYLER	SMITH
CHECK	CONTROL	SECTION	JOB
HMF	0910	16	165

2

GENERAL NOTES:

GENERAL.

Contractor questions on this project are to be addressed to the following individuals:

Juanita Daniels-West, P.E. Juanita.DanielsWest@txdot.gov

Steven Swindell, P.E. Steven.Swindell@txdot.gov

Contractor questions will be accepted through email, phone, and in person by the above individuals.

All Contractor questions will be reviewed by the Engineer. Once a response is developed, it will be posted to TxDOT's Public FTP at the following Address:

<https://ftp.dot.state.tx.us/pub/txdot-info/Pre-Letting%20Responses/>

All questions submitted that generate a response will be posted through this site. The site is organized by District, Project Type (Construction or Maintenance), Letting Date, CCSJ/Project Name.

For this Contract, the following standard sheets have been modified:

PM(4)-22 (MOD)

ITEM 5. CONTROL OF THE WORK

If utility lines need adjustments during construction operations, modify operations and continue the work in a manner that will allow others to make the utility adjustments. Additional working time may be allowed for delays caused by these utility adjustments.

Utility locations shown on the plans are approximate. Contact utilities in accordance with Article 5.6., "Cooperating With Utilities."

Verify survey control for accuracy before beginning construction.

Notify the Engineer if there are conflicts with survey control accuracy.

ITEM 7. LEGAL RELATIONS AND RESPONSIBILITIES

Concrete truck drivers and concrete pump operators are required to wash out only in designated areas specifically constructed for eliminating run-off. Dispose of materials in accordance with federal, state, and local requirements.

Maintain positive drainage for permanent and temporary work for the duration of the project. The Contractor will be responsible for any items associated with the temporary or interim drainage and all related maintenance. This work will be subsidiary to various bid items.

The total disturbed area for this project is 0.08 acres. The disturbed area in this project and the Contractor Project Specific Locations (PSL's) within 1 mile of the project limits for the Contract will further establish the authorization requirements for storm water discharges. The Department will obtain an authorization to discharge storm water from the Texas Commission on Environmental Quality (TCEQ) for the construction activities shown on the plans. Obtain any required authorization from the TCEQ for any Contractor PSL for construction support activities on or off the ROW. When the total area disturbed for all projects in the Contract and PSLs within 1 mile of the project limits exceed 5 acres, before disturbance, provide a copy of the Contractor NOI for PSLs on the ROW and within 1 mile of the project limits to the Engineer and to any local government that operates a Municipal Separate Storm Sewer System (MSSS).

No significant traffic generator events identified.

ITEM 8. PROSECUTION AND PROGRESS

Nighttime work is only allowed on this project with prior approval.

Prepare the progress schedule as a bar chart.

Special Provision 008-003 is included in this Contract. This is to allow for the manufacturer's delay in providing the traffic signal poles.

ITEM 9. MEASUREMENT & PAYMENT

In accordance with Article 9.1., "Measurement of Quantities," furnish the tare and maximum gross weights as well as the volume capacity of all vehicles, trucks, truck-tractors, trailers, semi-trailers, or combination of such vehicles used to deliver materials for this Contract. Also, furnish calculations supporting these weights and capacities. Provide all measurements required for pay a minimum of 2 days before the trucks are used.

ITEM 104. REMOVING CONCRETE

Before removing existing curb & gutter or laydown curb, saw cut between the gutter pan and the roadbed to eliminate the possibility of damage to the pavement structure. When the existing pavement edge has to be removed to facilitate the curb & gutter transition from existing to the proposed ramp landing, remove the old and replace the new pavement structure the same day unless otherwise directed. The use of temporary material may be allowed as approved. This work will be subsidiary to Item 104.

ITEM 416. DRILLED SHAFT FOUNDATIONS

Provide a low clearance drilling rig to avoid overhead transmission line.

ITEM 465. JUNCTION BOXES, MANHOLES, AND INLETS

Paint all iron manhole rings and covers with galvanized paint.

ITEM 502. BARRICADES, SIGNS, AND TRAFFIC HANDLING

The traffic control plan for this Contract consists of: the installation and maintenance of warning signs and other traffic control devices shown on the plans; specification data, which may be included in the general notes; applicable provisions of the Texas Manual on Uniform Traffic Control Devices (TMUTCD); traffic control plan sheets included on the plans; standard BC sheets; Compliant Work Zone Traffic Control Device List, and Item 502 of the standard specifications.

Use ground-mounted sign mounts with two posts for all temporary work zone signs unless otherwise directed.

Inspect and correct deficiencies each day throughout the duration of the Contract. In accordance with Article 502.4., "Payment," no payment will be made for the month if the Contractor fails to provide or properly maintain signs and devices in compliance with Contract requirements. Temporary warning signs that are visible when conditions do not apply will be considered improper maintenance of signs.

Provide at least one employee on call nights and weekends (or any other time that work is not in progress) for maintenance of signs and traffic control devices. This employee must have an address and telephone number near the project, as approved. Notify the Engineer in writing of the name, address, and telephone number of this employee. The Engineer will furnish this information to local law enforcement officials.

In addition to providing a Contractor's Responsible Person and a phone number for emergency contact, have an employee available to respond on the project for emergencies and for taking corrective measures within 30 minutes.

Sign all roads intersecting the project in accordance with current BC standards.

Refer to the traffic control plan sheets for traffic handling through the work area. Contractor may vary the signing arrangement and spacing as necessary to fit field conditions; however, any proposed changes in the traffic control plan must be approved before implementation.

When the sequence of work is shown on the plans, the Contractor may submit an alternate proposal for approval. Submit in writing all proposed variations and revisions.

High-visibility safety apparel is required for workers in accordance with the General Notes on current BC standards.

Place and maintain signs, channelizing devices, and flaggers to direct and route traffic at any location and for any period of time as may be required or directed.

When operations require a lane closure, provide cones, vertical panels, drums, signs, flaggers, and flashing arrow panels as necessary to route traffic around the closed lane as shown on the plans and as directed. Lane closures will be limited to one specific lane as directed.

Lane closures will not be allowed before 8:30 A.M. unless otherwise directed.

Unless otherwise approved, construction operations will not be allowed on Good Friday, Easter weekend, the Friday before Memorial Day thru Memorial Day, July 4th, the Friday before Labor Day thru Labor Day, the Wednesday before Thanksgiving Day thru Sunday, Christmas Eve, Christmas Day, New Year's Eve, New Year's Day, or on any other high traffic days or holidays as determined by the Engineer.

Erect R4-1 (Do Not Pass) and R4-2 (Pass With Care) signs to mark existing no-passing zones as directed. (These signs will not be required if these zones will not be eliminated during construction.)

Maintain existing roadside signs within this project's limits during this Contract. In order to accommodate the grading or other operations, temporarily relocate these signs in accordance with the TMUTCD as directed. Use ground-mounted sign mounts with two posts for all relocated signs unless otherwise directed. This work will not be paid for directly, but will be subsidiary to Item 502.

County: Smith

Control: 0910-16-165

Highway: MLK BLVD

Provide truck-mounted attenuators (TMA) as shown on the appropriate traffic control plan sheets. Provide a letter certifying that all TMA used on this project meet NCHRP 350 or AASHTO Manual for Assessing Safety Hardware (MASH) requirements.

Regulate all construction activities and equipment to minimize inconvenience to the traveling public. At points where it is necessary for trucks to stop, load, or unload, provide warning signs and flaggers to protect the traveling public.

The pavement must be entirely open to traffic each night. Remove or clearly barricade all material stockpiles, equipment left overnight, or any obstruction within 30 ft. of a travelway as approved.

The Contractor Force Account "Safety Contingency" is intended to be used for work zone enhancements that could not be foreseen in the project planning and design stage for the purpose of improving the effectiveness of the Traffic Control Plan. These enhancements will be mutually agreed upon by the Engineer and the Contractor's Responsible Person based on weekly or more frequent traffic management reviews on the project. The Engineer may choose to use existing bid items if it does not slow the implementation of enhancement.

Provide flaggers at county roads, commercial driveways, and other intersecting roadways deemed necessary by the Engineer to maintain control of the work zone during one-lane two-way operations. Provide communication radios to each flagger in the work zone and the pilot vehicle operator.

The use of Law Enforcement Officers (LEOs) will be required for this project. Before the preconstruction meeting, coordinate with local agencies to be prepared for staffing needs.

Provide uniformed LEOs with marked vehicles during work zone activities. The officer in marked vehicle will be located as approved to monitor or direct traffic during the closure. The Engineer will approve the method used to direct traffic at signalized intersections. Additional officers and vehicles may be provided when directed.

Complete the daily tracking form provided by the Department and submit invoices that agree with the tracking form for payment at the end of each month approved services were provided. Minimums, scheduling fees, etc. will not be paid; TxDOT will consider paying cancellation fees on a case-by-case basis.

All law enforcement personnel used in work zone traffic control must be trained for performing duties in work zones and are required to take "Safe and Effective Use of Law Enforcement Personnel in Work Zones" (Course #133119) which can be found online at the following site: www.nhi.fhwa.dot.gov.

County: Smith

Control: 0910-16-165

Highway: MLK BLVD

Certificates of completion should be available to all who finish the course. These should be kept by the officers to verify completion when reporting to the work site.

With prior approval, provide uniformed law enforcement officers for traffic control during construction operations at the signalized intersections unless other traffic control measures are approved. The law enforcement officer's intersection control force account is under control 0910-16-165.

Prior to beginning work, the Contractor and Engineer must agree on the allowable length of lane closure.

Provide at least 1 person to be on the project and on duty at all times during the 1-lane detour operations for maintenance of the temporary traffic signals and other traffic control devices through the bridge construction area. Notify the Engineer in writing of the name, address and telephone number of this employee, or these employees. The Engineer will furnish this information to local law enforcement officials.

Place Type 3 barricades and road closed signs as shown on current BC standards across the closed roadway or the new location at each road, street, closed bridge, and along the closed roadway or new location at 3/4-mi. intervals.

Restrict movement of construction equipment and haul trucks to all paved surfaces. Do not allow construction equipment and haul trucks to cross the median unless specifically authorized. Use entrance and exit ramps for ingress and egress to the main lanes.

When operations require a sidewalk closure, use traffic control devices that control pedestrian flow as necessary to route pedestrians around the closed sidewalk as shown on sidewalk closures and bypass walkway sheet as directed.

All work required by these general notes, except as provided for by Item 502, will not be paid for directly, but will be subsidiary to Item 502 unless otherwise shown on the plans.

ITEM 506. TEMPORARY EROSION, SEDIMENTATION, AND ENVIRONMENTAL CONTROLS

Remove dirt, silt, rocks, debris, and other foreign matter that accumulates in all structures due to project erosion and Contractor's operations. Keep stream channels open at all times. This work will not be paid for directly but will be subsidiary to this Item.

The Engineer will provide copies of documents to meet TxDOT's posting requirements. Laminate, post, and maintain these documents at the project limits and at major roadways intersecting the project as directed. Post required Contractor documents in the same manner and location. This work will be subsidiary to Item 506.

Project Number:

Sheet 3C

County: Smith

Control: 0910-16-165

Highway: MLK BLVD

ITEM 529. CONCRETE CURB, GUTTER, AND COMBINED CURB AND GUTTER

Provide steel reinforcement for all curb and curb and gutter unless otherwise directed.

ITEM 531. SIDEWALKS

Provide steel reinforcement for all sidewalks unless otherwise directed.

ITEM 618. CONDUIT

Conduit placed on the underside of the bridge slab overhang must be anchored with conduit straps at 5 ft. maximum intervals as shown on standard sheets ED(1) and (2)-14. Conduit hangers will not be allowed in this location.

Where conduit is to be placed under existing riprap, cut the existing riprap to neat lines as directed and replace to match original condition after conduit placement.

The Contractor may, at his option, substitute high-density polyethylene (HDPE) conduit meeting the specifications of Item 622 for all bores requiring PVC schedule 40 conduit and, when approved by the Engineer, may substitute HDPE for schedule 80 bored conduit. HDPE must be the same size as the PVC conduit shown on the plans. HDPE must be terminated with UL listed fittings. HDPE may be threaded and used with threaded PVC connectors or couplings. HDPE should be extended through the bore in one continuous piece and should be coupled to RMC elbows or to PVC conduit at the bore pits prior to entering ground boxes (if ground boxes are required by the plans). HDPE should not contain conductors during installation in this manner. No additional compensation will be paid to the Contractor when HDPE is substituted for this purpose.

Do not use cast iron junction boxes in concrete traffic barriers and single slope traffic barriers. Use polymer concrete junction boxes instead of the cast iron junction boxes shown on standard sheets CSB(3), CSB(4), and SSCB(4). Mount the junction boxes flush (+ 0 in., - 1/2 in.) with concrete surface of concrete barrier.

The polymer concrete barrier box will not be paid for separately, but will be subsidiary to Item 618, "Conduit."

Use materials from prequalified material producers list as shown on the Material Producer List found on the TxDOT web site. Category is "Roadway Illumination and Electrical Supplies."

Project Number:

Sheet 3C

County: Smith

Control: 0910-16-165

Highway: MLK BLVD

ITEMS 618, 624, 680 & 684. CONDT, GRND BX, INSTL HWY TRF SIG & TRF SIG CBL

The location of the controller, conductors, conduits, junction boxes and ground boxes are diagrammatic only and may be shifted by the Engineer to accommodate field conditions.

ITEM 624. GROUND BOXES

All ground boxes will be precast polymer concrete of the size and type specified on the plans.

ITEM 636. SIGNS

Install signs in accordance with the Department of Transportation's "Sign Crew Field Book," latest edition, or as directed.

ITEM 644. SMALL ROADSIDE SIGN ASSEMBLIES

Sign types for which details are not shown on the plans must conform to "Standard Highway Sign Designs for Texas," latest edition.

Before construction begins, locate all Texas Reference Marker (TRM) signs and Adopt-a-Highway signs using survey control methods for accuracy. Provide the survey data to the Engineer. If either type of sign is relocated during construction activities, survey the sign location and notify the Engineer before placement of the permanent sign. Stake all sign locations for approval prior to placement.

ITEM 656. FOUNDATIONS FOR TRAFFIC CONTROL DEVICES

The Contractor may reduce the size of the traffic signal controller slab as shown on standard sheet TS-CF in order to accommodate site conditions as approved by the Engineer.

ITEM 666. RETROREFLECTORIZED PAVEMENT MARKINGS

Use the spray method for application of the thermoplastic compound for lane lines, barrier lines, edge lines and channelizing lines.

In high traffic volume areas, do not begin work before 9 A.M. and do not continue work after 4 P.M. unless otherwise approved. In other areas, the Engineer will approve and direct the time of work.

Extrude hot to the pavement surface thermoplastic compound for arrows, stop lines, yield triangles, transverse lines, crosswalk lines, words and symbols.

For lengths greater than 300-ft, provide guide markings that will not leave a permanent mark on the roadway. Have the guide marking material and equipment used for placement approved prior to use. Provide adequate notification for approval of the guide markings prior to placement of the permanent pavement markings.

Provide a crew experienced in the work of installing pilot guideline markings and in the necessary traffic control. Supply all the equipment, personnel, traffic control, and materials necessary for the placement of pilot guideline markings as directed. All work will be in conformance with Part 6 of the TMUTCD.

Correct deficiencies in the alignment of pavement markings at Contractor's expense, as directed. Use a strip seal with aggregate and asphalt types and rates as directed to eliminate the deficient pavement markings.

ITEM 672. RAISED PAVEMENT MARKERS

Provide dispensing equipment such that the bituminous material can be directly applied from the melting pot to the pavement surface without secondary handling. Dispensing material from the melting pot into a separate container and then to the pavement surface will not be permitted.

Intermittent agitation of the bituminous material will be by a method approved by the Engineer to ensure even heat distribution and must be such that the adhesive is agitated at approved and consistent intervals.

ITEM 677. ELIMINATING EXISTING PAVEMENT MARKINGS AND MARKERS

Unless otherwise directed, utilize Surface Treatment Method for removal on asphaltic surfaces. The Engineer will approve materials and rates prior to use.

Furnish a high-pressure water blasting system for removing paint, thermoplastic, epoxy and preformed tape material from the following surfaces without causing any grooves or trenching of the surface: asphalt, concrete, permeable friction course, grooved asphalt and grooved concrete.

Use a high-pressure water blasting system that consists of a vacuum recovery system that must provide for a nearly dry surface eliminating the possibility of uncontained run-off blasting water or debris, or the need for any secondary clean-up vehicles or operations.

All components required for the complete operation of the water blasting system (ultra-high-pressure pump, vacuum system, clean water supply, vacuum recovery storage, primary truck-mounted and optional secondary tractor-mounted blasting components)

must be mounted and transported on a single, fully self-contained and supporting single truck chassis, thereby eliminating the need for any additional water, vacuum or other transport vehicles.

ITEM 680. INSTALLATION OF HIGHWAY TRAFFIC SIGNALS

A manufacturer's representative must be present when the signal lights are placed in operation.

Provide a uniformed law enforcement officer to maintain traffic control when the signal lights are placed in operation and at any time the normal signal operation is interrupted due to failure of Contractor supplied materials or workmanship.

The Contractor's maintenance responsibility begins on the day work is authorized and continues until final acceptance. Designate in writing an IMSA certified signal technician who is available to perform repair work within a 2-hour response time at all times. This work will not be paid for directly but will be subsidiary to Item 680.

Furnish, install, and test Cellular Router – Applied Information AI-500-085-02 Glance Peempt & Priority or equivalent Cellular Router with power supply and power cable assembly. Furnish equipment with 10-year cellular data subscription service with passthrough & video, and Glance Software Configuration.

Install Cellular Router in equipment cabinets in accordance with this Item and details and dimensions as shown on the plans or as directed. Maintain safe construction practices. Equipment will be installed in a neat and workmanlike manner. Adjustments or additions of attachment hardware, support brackets, and appurtenances may be necessary for compatibility, as shown on the plans, or as directed.

Prevent damage to all components. Any unused or removed material deemed salvageable by the Engineer will remain the property of the respective agency and must be delivered to a designated site. Accept ownership of unsalvageable materials and dispose of in accordance with federal, state, and local regulations. Stockpile all materials designated for reuse or to be retained by the respective agency within the project limits or at a designated location as directed.

Equipment to be installed at signal cabinet shown on the plans may include, but not be limited to, the following:

- Cellular Router (provided by the Contractor),
- Cabling and connectors from power source to Cellular Router connection point as specified by the manufacturer (provided by the Contractor),
- Cabling and connectors from telecommunications source to Cellular Router connection point as specified by the Cellular Router manufacturer when required (provided by the Contractor), and

- External Antennas for communications as shown on the plans.

Make all arrangements for connection to the power supply and telecommunications source including any required permits. Supply and install any required materials not provided by the utility companies (power or communications service provider).

Cellular Routers and all related accessories will be assembled on an equipment rack. All items need to be tied to the rack. Screw the equipment rack in the suitable location in the cabinet. Cabinet adjustments or additions of attachment hardware, support racks or brackets may be necessary. All adjustments or additional materials will not be paid for directly but will be subsidiary to this Item.

Install external antennas of the router on the top of the cabinet at optimum location as recommended by the manufacturer. Please follow the manufacturer instruction carefully to water seal the antenna to prevent water leaking. Each Cellular Router will be provided with 20 ft. of coax cable with weather resistant connectors installed to connect the antenna to the Cellular Router.

The work performed, and materials furnished in accordance with this Item will be paid for as subsidiary to Item 680. This price is full compensation for furnishing and installation of Cellular Router, procurement of 10-year cellular data subscription service with passthrough & video, and Glance Software Configuration, and installing any new mounting hardware; storing the Cellular Router when required; testing the Cellular Router; replacement or repair of damaged components; disposal of unsalvageable material and for all manipulations, labor, tools, working drawings, equipment and incidentals.

ITEM 682. VEHICLE AND PEDESTRIAN SIGNAL HEADS

Fabricate the traffic signal heads using polycarbonate. Cover the traffic signal heads with factory-made signal head covers until placed in operation.

ITEM 684. TRAFFIC SIGNAL CABLES

An extra length of 5 ft. for each cable run must remain in each steel signal pole. For each conductor that terminates in the controller cabinet, an extra 5-ft. length must be provided. Wire nuts will not be permitted.

ITEM 686. TRAFFIC SIGNAL POLE ASSEMBLIES (STEEL)

All poles must be round and powder-coated black.

ITEM 688. PEDESTRIAN DETECTORS & VEHICLE LOOP DETECTORS

When installing traffic signal detectors, close only one lane of a roadway at a time. Conduct construction operations to provide the least possible interference to traffic as provided in the specifications or as directed.

ITEM 6001. PORTABLE CHANGEABLE MESSAGE SIGN

Provide a non-erodible, stable surface to place the Portable Changeable Message Sign (PCMS) units adjacent to the roadway as directed. Payment for this surface is incidental to Item 6001.

ITEM 6185. TRUCK MOUNTED ATTENUATOR (TMA)

Shadow vehicles with truck mounted attenuator (TMA) are required on the traffic control plan and TCP standards for this project. The Contractor will be responsible for determining if one or more of these traffic control operations will be ongoing at the same time to determine the total number of TMAs needed for the project. Additional truck mounted attenuators (TMAs) may be required as deemed necessary by the Engineer.

ITEM 6306. VIDEO IMAGING DETECTION SYSTEM

Each VIVDS must include all necessary hardware and software to adjust all detection zone features.

All VIVDS processors and cameras must be from same manufacturers for the duration of this Contract.

All camera cables must be inside the camera support arm.

Use coaxial cable meeting the requirements of Special Specification 6306 for the field communications link.

All software must be windows 10 compatible.

Deliver all system setup disks, including the original operating system setup disks, to the Tyler District Signal Shop at 2709 West Front Street.

CITY OF TYLER NOTES:

1. THE GOVERNING SPECIFICATIONS FOR THIS PROJECT ARE AS FOLLOWS: TxDOT STANDARD SPECIFICATIONS FOR CONSTRUCTION AND MAINTENANCE OF HIGHWAYS, STREETS, AND BRIDGES, 2014 ED.
2. ALL WORK ON THESE PLANS SHALL BE DONE IN STRICT ACCORDANCE WITH THE APPLICABLE CITY OF TYLER/TxDOT SPECIFICATIONS.
3. THE CONTRACTOR IS RESPONSIBLE FOR OBTAINING ALL NECESSARY PERMITS AND APPROVALS BEFORE CONSTRUCTION BEGINS.
4. CONSTRUCTION SHALL COMPLY WITH ALL GOVERNING CODES AND REQUIREMENTS. CONTRACTOR SHALL CONDUCT ALL REQUIRED TESTS TO THE SATISFACTION OF THE OWNER'S INSPECTING AUTHORITIES.
5. EXISTING FACILITIES AND UTILITIES ARE SHOWN IN APPROXIMATE LOCATIONS PER INFORMATION AND RECORDS AVAILABLE. CONTRACTOR IS RESPONSIBLE FOR VERIFYING ALL UTILITIES AND NOTIFYING THE APPROPRIATE UTILITY COMPANY PRIOR TO BEGINNING CONSTRUCTION. CONTACT CITY OF TYLER WATER SERVICE CENTER AT 903-531-1285 FOR WET UTILITY LOCATES.
6. THE CONTRACTOR SHALL TAKE ALL NECESSARY PRECAUTIONS TO PROTECT EXISTING FACILITIES FROM DAMAGE. ANY DAMAGE TO EXISTING FACILITIES RESULTING FROM CONSTRUCTION WORK SHALL BE REPAIRED AT THE CONTRACTOR'S EXPENSE.
7. THE CONTRACTOR SHALL CONTACT THE CITY OF TYLER AT (903) 531-1292 A MINIMUM OF ONE WEEK PRIOR TO THE BEGINNING OF ANY SIGNAL WORK. THE CONTRACTOR SHALL DELIVER ANY SALVAGEABLE MATERIAL, AS DETERMINED BY THE CITY, TO THE SIGNAL SHOP LOCATED AT 406 W. OAKWOOD, TYLER, TX 75702.
8. THE CITY OF TYLER IS TO BE NOTIFIED 48 HOURS (2 WORKING DAYS) PRIOR TO ANY PLANNED WORK ON SATURDAYS. NO WORK IS ALLOWED ON SUNDAYS OR HOLIDAYS. WORKING HOURS DURING WEEKDAYS ARE 7 AM TO 7 PM. HOURS ARE 9 AM TO 7 PM ON SATURDAYS IF PRE-APPROVED.
9. A SIGNAL TECHNICIAN FROM THE CITY OF TYLER SHALL BE PRESENT WHEN THE PEDESTRIAN SIGNALS ARE PLACED IN OPERATION. THE CONTRACTOR SHALL NOTIFY THE CITY AT LEAST 48 HOURS IN ADVANCE OF TURN ON.
10. TEST PERIOD FOR PEDESTRIAN SIGNALS – ONCE THE PERMANENT PEDESTRIAN SIGNALS HAVE BEEN INSTALLED AND PLACED IN OPERATION, THEY SHALL OPERATE CONTINUOUSLY FOR A MINIMUM OF 30 CALENDAR DAYS IN A SATISFACTORY MANNER. EQUIPMENT FAILURES DURING THESE 30 DAYS WILL CAUSE THE TEST PERIOD TO START OVER.
11. COMMUNICATION SETTINGS WILL BE PROVIDED BY THE CITY OF TYLER.
12. NO TRAFFIC SIGNS ARE TO BE RELOCATED OR REMOVED WITHOUT PRIOR APPROVAL OF THE CITY OF TYLER.
13. CONDUIT BOXES SHALL HAVE EXTRA CABLE LENGTH INCLUDED IN EACH RUN TO PROVIDE ADEQUATE SLACK, AS DETERMINED BY THE CITY, AT EACH GROUND BOX OR FOUNDATION.
14. ALL PEDESTRIAN POLES SHALL BE POWDER COATED BLACK.
15. NO PEDESTRIAN POLES SHALL BE PLACED ON THE FOUNDATIONS PRIOR TO SEVEN (7) DAYS FOLLOWING PLACEMENT OF CONCRETE.
16. SIGNAL HOUSINGS AND VISORS SHALL BE BLACK IN COLOR. BACKPLATES SHALL BE POLYCARBONATE.
17. UNLESS OTHERWISE SHOWN ON THE PLANS, SIGNAL HEADS SHALL HAVE LED SIGNAL INDICATIONS.

18. ALL SIGNAL HEADS SHALL BE COVERED WITH BURLAP OR OTHER APPROVED MATERIAL FROM THE TIME OF INSTALLATION UNTIL THE SIGNAL IS PLACED IN OPERATION.
19. NO EXPOSED CABLE OR WIRING WILL BE PERMITTED.
20. THE TRAFFIC SIGNAL INSTALLATION CONSISTS OF THE FOLLOWING ITEMS:
 - a. INSTALLING COMMUNICATION EQUIPMENT.
 - b. FURNISHING AND INSTALLING FOUNDATION PER PLANS AND SPECIFICATIONS.
 - c. FURNISHING AND INSTALLING VEHICLE DETECTORS, PEDESTRIAN PUSH BUTTONS (ACCESSIBLE PEDESTRIAN SIGNALS), AND DETECTOR CABLES.
 - d. FURNISHING AND INSTALLING TRAFFIC SIGNAL SIGNS.
 - e. FURNISHING AND INSTALLING PEDESTRIAN SIGNAL POLES ACCORDING TO TxDOT SPECIFICATIONS.
 - f. FURNISHING AND INSTALLING ALL CONCRETE AND REINFORCING STEEL FOR THE PEDESTRIAN POLE FOUNDATIONS.
 - g. FURNISHING AND INSTALLING STANDARD GROUND BOXES WITH APRONS AS SHOWN ON PLANS.
 - h. FURNISHING AND INSTALLING LED COUNTDOWN PEDESTRIAN SIGNAL LAMPS, AND SIGNAL CABLES.
 - i. THE CONTRACTOR SHALL ALSO FURNISH AND INSTALL ALL OTHER ITEMS NOT LISTED ABOVE WHICH ARE NEEDED TO PROVIDE THE COMPLETE TRAFFIC SIGNAL INSTALLATION AS CALLED FOR IN THE PLANS AND SPECIFICATIONS.

PLOTTED: 5/13/2022 4:00:00 PM / in. BY: Marianne Borrero
 FILENAME: K:\DAL_TPTO\project\063615008 - Tyler HSIP PS&E\CADD\TYL-HSIP_T1_010_3C_GENERAL NOTES.MLK.dgn

5/13/2022





13455 Noel Road
Two Galleria Office Tower, Suite 700
Dallas, Texas 75240

Tel. No. (972) 770-1300
Fax No. (972) 239-3820





© 2022

TRAFFIC SAFETY IMPROVEMENTS

CITY OF TYLER

TRAFFIC SIGNAL GENERAL NOTES

DESIGN	FED. RD. DIV. NO.	FEDERAL AID PROJECT NO.		HIGHWAY NO.
HMF	6	(SEE TITLE SHEET)		CS
GRAPHICS	STATE	DISTRICT	COUNTY	SHEET NO.
MB	TEXAS	TYLER	SMITH	4
CHECK ASA	CONTROL	SECTION	JOB	
CHECK HMF	0910	16	165	



CONTROLLING PROJECT ID 0910-16-165

DISTRICT Tyler
HIGHWAY MLK JR BLVD

COUNTY Smith

Estimate & Quantity Sheet

CONTROL SECTION JOB				0910-16-165		TOTAL EST.	TOTAL FINAL
PROJECT ID				A00177655			
COUNTY				Smith			
HIGHWAY				MLK JR BLVD			
ALT	BID CODE	DESCRIPTION	UNIT	EST.	FINAL		
	104-6001	REMOVING CONC (PAV)	SY	5.000		5.000	
	162-6002	BLOCK SODDING	SY	10.000		10.000	
	500-6001	MOBILIZATION	LS	1.000		1.000	
	502-6001	BARRICADES, SIGNS AND TRAFFIC HANDLING	MO	2.000		2.000	
	506-6040	BIODEG EROSN CONT LOGS (INSTL) (8")	LF	120.000		120.000	
	506-6043	BIODEG EROSN CONT LOGS (REMOVE)	LF	120.000		120.000	
	529-6002	CONC CURB (TY II)	LF	15.000		15.000	
	531-6003	CONC SIDEWALKS (6")	SY	32.000		32.000	
	531-6008	CURB RAMPS (TY 5)	EA	1.000		1.000	
	531-6010	CURB RAMPS (TY 7)	EA	6.000		6.000	
	618-6046	CONDT (PVC) (SCH 80) (2")	LF	70.000		70.000	
	618-6059	CONDT (PVC) (SCH 80) (4") (BORE)	LF	360.000		360.000	
	620-6009	ELEC CONDR (NO.6) BARE	LF	430.000		430.000	
	624-6010	GROUND BOX TY D (162922)W/APRON	EA	4.000		4.000	
	624-6028	REMOVE GROUND BOX	EA	4.000		4.000	
	666-6036	REFL PAV MRK TY I (W)8"(SLD)(100MIL)	LF	390.000		390.000	
	666-6048	REFL PAV MRK TY I (W)24"(SLD)(100MIL)	LF	530.000		530.000	
	666-6224	PAVEMENT SEALER 4"	LF	1,640.000		1,640.000	
	666-6226	PAVEMENT SEALER 8"	LF	390.000		390.000	
	666-6230	PAVEMENT SEALER 24"	LF	530.000		530.000	
	666-6231	PAVEMENT SEALER (ARROW)	EA	3.000		3.000	
	666-6232	PAVEMENT SEALER (WORD)	EA	3.000		3.000	
	666-6300	RE PM W/RET REQ TY I (W)4"(BRK)(100MIL)	LF	290.000		290.000	
	666-6303	RE PM W/RET REQ TY I (W)4"(SLD)(100MIL)	LF	150.000		150.000	
	666-6315	RE PM W/RET REQ TY I (Y)4"(SLD)(100MIL)	LF	1,200.000		1,200.000	
	668-6077	PREFAB PAV MRK TY C (W) (ARROW)	EA	3.000		3.000	
	668-6085	PREFAB PAV MRK TY C (W) (WORD)	EA	3.000		3.000	
	672-6007	REFL PAV MRKR TY I-C	EA	80.000		80.000	
	672-6009	REFL PAV MRKR TY II-A-A	EA	30.000		30.000	
	677-6001	ELIM EXT PAV MRK & MRKS (4")	LF	1,640.000		1,640.000	
	677-6003	ELIM EXT PAV MRK & MRKS (8")	LF	390.000		390.000	
	677-6007	ELIM EXT PAV MRK & MRKS (24")	LF	530.000		530.000	
	677-6008	ELIM EXT PAV MRK & MRKS (ARROW)	EA	6.000		6.000	
	678-6001	PAV SURF PREP FOR MRK (4")	LF	1,640.000		1,640.000	
	678-6004	PAV SURF PREP FOR MRK (8")	LF	390.000		390.000	
	678-6008	PAV SURF PREP FOR MRK (24")	LF	530.000		530.000	
	678-6009	PAV SURF PREP FOR MRK (ARROW)	EA	3.000		3.000	



DISTRICT	COUNTY	CCSJ	SHEET
Tyler	Smith	0910-16-165	5



Estimate & Quantity Sheet

CONTROLLING PROJECT ID 0910-16-165

DISTRICT Tyler
HIGHWAY MLK JR BLVD

COUNTY Smith

CONTROL SECTION JOB				0910-16-165		TOTAL EST.	TOTAL FINAL
PROJECT ID				A00177655			
COUNTY				Smith			
HIGHWAY				MLK JR BLVD			
ALT	BID CODE	DESCRIPTION	UNIT	EST.	FINAL		
	678-6016	PAV SURF PREP FOR MRK (WORD)	EA	3.000		3.000	
	680-6011	INSTALL HWY TRF SIG (UPGRADE)	EA	2.000		2.000	
	682-6018	PED SIG SEC (LED)(COUNTDOWN)	EA	8.000		8.000	
	684-6031	TRF SIG CBL (TY A)(14 AWG)(5 CONDR)	LF	80.000		80.000	
	684-6036	TRF SIG CBL (TY A)(14 AWG)(10 CONDR)	LF	490.000		490.000	
	684-6079	TRF SIG CBL (TY C)(12 AWG)(2 CONDR)	LF	970.000		970.000	
	687-6001	PED POLE ASSEMBLY	EA	5.000		5.000	
	688-6001	PED DETECT PUSH BUTTON (APS)	EA	8.000		8.000	
	688-6003	PED DETECTOR CONTROLLER UNIT	EA	1.000		1.000	
	6001-6001	PORTABLE CHANGEABLE MESSAGE SIGN	DAY	20.000		20.000	
	6027-6003	CONDUIT (PREPARE)	LF	115.000		115.000	
	6185-6002	TMA (STATIONARY)	DAY	7.000		7.000	
	6185-6005	TMA (MOBILE OPERATION)	DAY	2.000		2.000	
	6306-6001	VIVDS PROSR SYS	EA	1.000		1.000	
	6306-6002	VIVDS CAM ASSY FXD LNS	EA	4.000		4.000	
	6306-6005	VIVDS CNTRL SOFTWARE	EA	1.000		1.000	
	6306-6007	VIVDS CABLING	LF	710.000		710.000	
18		SAFETY CONTINGENCY: CONTRACTOR FORCE ACCOUNT WORK (PARTICIPATING)	LS	1.000		1.000	
		EROSION CONTROL MAINTENANCE: CONTRACTOR FORCE ACCOUNT WORK (PART)	LS	1.000		1.000	
		LAW ENFORCEMENT: CONTRACTOR FORCE ACCOUNT WORK (PARTICIPATING)	LS	1.000		1.000	

BASIS OF ESTIMATE

ITEM	DESCRIPTION	CSJ 0190-16-165 AMOUNT	UNIT	PAY UNIT
500	MOBILIZATION	1.0	LS	LS
502	BARRICADES, SIGNS AND TRAFFIC HANDLING	2.0	MO	MO

ROADWAY SUMMARY

LOCATION	ITEM 104	ITEM 529	ITEM 531		
	REMOVING CONC (PAV)	CONC CURB (TY II)	CONC SIDEWALKS (6")	CURB RAMPS (TY 5)	CURB RAMPS (TY 7)
	SY	LF	SY	EA	EA
CSJ 0910-16-165 SUBTOTAL	5	15	32	1	6
PROJECT TOTAL	5	15	32	1	6

PORTABLE CHANGEABLE MESSAGE SIGN

SIGN	LOCATION	ITEM 6001
		PORTABLE CHANGEABLE MESSAGE SIGN
		DAYS
SIGN #1	AS DIRECTED	10
SIGN #2	AS DIRECTED	10
PROJECT TOTAL		20

PAVEMENT MARKING SUMMARY

LOCATION	ITEM 666								ITEM 668			ITEM 672		ITEM 677				ITEM 678						
	REFL PAV MRK TY I (100MIL)		PAVEMENT SEALER						RE PM W/RET REQ TY I (100MIL)			PREFAB PAV MRK TY C		REFL PAV MRKR		ELIM EXT PAV MRK & MRKS				PAV SURF PREP FOR MRK				
	(W)		4"	8"	24"	(ARROW)	(WORD)	(W)			(Y)	(W)		TY I	TY II	4"	8"	24"	(ARROW)	4"	8"	24"	(ARROW)	(WORD)
	8" (SLD)	24" (SLD)	4"	8"	24"	EA	EA	4" (BRK)	4" (SLD)	4" (SLD)	EA	EA	EA	EA	EA	EA	EA	EA	EA	EA	EA	EA	EA	EA
CSJ 0910-16-165 SUBTOTAL	390	530	1640	390	530	3	3	290	150	1200	3	3	80	30	1640	390	530	6	1640	390	530	3	3	
PROJECT TOTAL	390	530	1640	390	530	3	3	290	150	1200	3	3	80	30	1640	390	530	6	1640	390	530	3	3	

NOTE: MULTIPLE MOVE-INS WILL BE REQUIRED TO MAINTAIN COMPLIANCE WITH THE TMUTCD

Kimley»Horn

13455 Noel Road
Two Galleria Office Tower, Suite 700
Dallas, Texas 75240

F-928
Tel. No. (972) 770-1300
Fax No. (972) 239-3820



Texas Department of Transportation
© 2022

TRAFFIC SAFETY IMPROVEMENTS

SUMMARY OF QUANTITIES

SHEET 1 OF 2

DESIGN	FED. RD. DIV. NO.	FEDERAL AID PROJECT NO.	HIGHWAY NO.
HMF	6	(SEE TITLE SHEET)	CS
GRAPHICS	STATE	DISTRICT	COUNTY
MB	TEXAS	TYLER	SMITH
CHECK	CONTROL	SECTION	JOB
ASA	0910	16	165
CHECK			
HMF			6

PLOTTED: 5/13/2022 40,000 ft / in. FILENAME: \\kimley-horn.com\TX_DAL2\DAL_TPTO\project\063615008 - Tyler_HSP_PS&E\CADD\TYL-HSIP_T1_010_3B_QUANTITY_SUMMARY_MLK.dgn

SIGNAL SUMMARY																			
LOCATION	ITEM 416	ITEM 618		ITEM 620	ITEM 624	ITEM 624	ITEM 680	ITEM 682	ITEM 684			ITEM 687	ITEM 688		ITEM 6027	ITEM 6306			
	DRILL SHAFT (TRF SIG POLE) (24 IN) [1]	2" PVC SCH 80 (TRENCH) LF	4" PVC SCH 80 (BORED) LF	ELEC CONDR (NO. 6) BARE LF	GROUND BOX TY D (162922) W/ APRON EA	REMOVE GROUND BOX EA	INSTALL HWY TRF SIG (UPGRADE) EA	PED SIG SEC (LED) (COUNT DOWN) EA	TRF SIG CBL			PED POLE ASSEM BLY EA	PED DETECT CONTROL UNIT EA	PED DETECT PUSH BUTTON (APS) EA	CONDUIT PREPARE LF	VIVIDS			
									(TY A) (14 AWG)		(TY C) (12 AWG)					PROSR SYS EA	CAM ASSY FXD LNS EA	CNTRL SOFTWARE EA	CABLING LF
									(5 CONDR)	(10 CONDR)	(2 CONDR)								
MLK BLVD AT PALACE AVE	0	0	0	0	0	1	0	0	0	0	0	0	0	0	0	0	0	0	
MLK BLVD AT BROADWAY AVE	30	70	360	430	4	4	1	8	80	490	970	5	1	8	115	1	4	1	710
CSJ 0910-16-165 SUBTOTAL	30	70	360	430	4	4	2	8	80	490	970	5	1	8	115	1	4	1	710
TOTAL	30	70	360	430	4	4	2	8	80	490	970	5	1	8	115	1	4	1	710

[1] FOR CONTRACTOR INFORMATION ONLY; PEDESTRIAN POLE FOUNDATIONS ARE SUBSIDIARY TO ITEM 687. OPTIONAL CONCRETE FOUNDATION SHOWN FOR EXAMPLE

TRUCK MOUNTED ATTENUATORS			
STAGE OF PROJECT	NUMBER OF TRUCKS	ITEM 6185	ITEM 6185
		TMA (STATIONARY)	TMA (MOBILE)
		DAY	DAY
MOBILE	2	-	2
STATIONARY	1	7	-
CSJ 0910-16-165 SUBTOTAL	3	7	2
PROJECT TOTAL		7	2

NOTE: ESTIMATED NUMBER OF TRUCKS IS FOR WORKING AT ONE LOCATION AT A TIME.
ADDITIONAL TRUCKS WILL BE REQUIRED IF WORKING AT MULTIPLE LOCATIONS AT A TIME.

EROSION CONTROL SUMMARY			
LOCATION	ITEM 162	ITEM 506	
	BLOCK SODDING	BIODEG EROSN CONT LOGS	
	SY	(IN STL) (8") LF	(REMOVE) LF
0110-16-165 SUBTOTAL	10	120	120
PROJECT TOTAL	10	120	120

NOTE: MULTIPLE MOVE-INS WILL BE REQUIRED TO MAINTAIN ADEQUATE VEGETATION IN COMPLIANCE WITH THE CONSTRUCTION GENERAL PERMIT.

5/13/2022



Kimley»Horn F-928

13455 Noel Road
Two Galleria Office Tower, Suite 700
Dallas, Texas 75240
Tel. No. (972) 770-1300
Fax No. (972) 239-3820



® Texas Department of Transportation
© 2022

TRAFFIC SAFETY IMPROVEMENTS

SUMMARY OF QUANTITIES

SHEET 2 OF 2

DESIGN HMF	FED. RD. DIV. NO. 6	FEDERAL AID PROJECT NO. (SEE TITLE SHEET)	HIGHWAY NO. CS
GRAPHICS MB	STATE TEXAS	DISTRICT TYLER	COUNTY SMITH
CHECK ASA	CONTROL	SECTION	JOB
CHECK HMF	0910	16	165

6A

CONSTRUCTION SEQUENCE

1. INSTALL PROJECT SIGNS.
2. OBTAIN UTILITY INFORMATION FROM 811, TXDOT, AND CITY OF TYLER.
3. INSTALL PEDESTRIAN POLE DRILLED SHAFTS.
4. CONSTRUCT PROPOSED PEDESTRIAN RAMPS AND SIDEWALK FACILITIES ACCORDING TO LAYOUTS.
5. SCHEDULE AND ATTEND PRE STRIPING MEETING.
6. PLACE TYPE I PAVEMENT MARKINGS AND RPMS ACCORDING TO LAYOUTS.
7. PERFORM FINAL CLEAN-UP.
8. REMOVE PROJECT SIGNS.

PLOTTED: 5/13/2022 4:00:00 PM / in. BY: Marjanna Borrero
 FILENAME: K:\DAL_TPTO\project\063615008 - Tyler HSIP PS&E\CADD\TYL-HSIP_T1_010_4_CONSTRUCTION_SEQ_MLK.dgn

5/13/2022



Kimley»Horn

F-928
 13455 Noel Road
 Two Galleria Office Tower, Suite 700
 Dallas, Texas 75240
 Tel. No. (972) 770-1300
 Fax No. (972) 239-3820



CITY OF TYLER



© 2022

TRAFFIC SAFETY IMPROVEMENTS

CONSTRUCTION SEQUENCE

DESIGN	FED. RD. DIV. NO.	FEDERAL AID PROJECT NO.		HIGHWAY NO.
HMF	6	(SEE TITLE SHEET)		CS
MB	STATE	DISTRICT	COUNTY	SHEET NO.
CHECK ASA	TEXAS	TYLER	SMITH	7
CHECK HMF	CONTROL	SECTION	JOB	
	0910	16	165	

DISCLAIMER: The use of this standard is governed by the "Texas Engineering Practice Act". No warranty of any kind is made by TxDOT for any purpose whatsoever. TxDOT assumes no responsibility for the conversion of this standard to other formats or for incorrect results or damages resulting from its use.

DATE: DATE TIME
 FILE: DOCUMENT NAME

BARRICADE AND CONSTRUCTION (BC) STANDARD SHEETS GENERAL NOTES:

1. The Barricade and Construction Standard Sheets (BC sheets) are intended to show typical examples for placement of temporary traffic control devices, construction pavement markings, and typical work zone signs. The information contained in these sheets meet or exceed the requirements shown in the "Texas Manual on Uniform Traffic Control Devices" (TMUTCD).
2. The development and design of the Traffic Control Plan (TCP) is the responsibility of the Engineer.
3. The Contractor may propose changes to the TCP that are signed and sealed by a licensed professional engineer for approval. The Engineer may develop, sign and seal Contractor proposed changes.
4. The Contractor is responsible for installing and maintaining the traffic control devices as shown in the plans. The Contractor may not move or change the approximate location of any device without the approval of the Engineer.
5. Geometric design of lane shifts and detours should, when possible, meet the applicable design criteria contained in manuals such as the American Association of State Highway and Transportation Officials (AASHTO), "A Policy on Geometric Design of Highways and Streets," the TxDOT "Roadway Design Manual" or engineering judgment.
6. When projects abut, the Engineer(s) may omit the END ROAD WORK, TRAFFIC FINES DOUBLE, and other advance warning signs if the signing would be redundant and the work areas appear continuous to the motorists. If the adjacent project is completed first, the Contractor shall erect the necessary warning signs as shown on these sheets, the TCP sheets or as directed by the Engineer. The BEGIN ROAD WORK NEXT X MILES sign shall be revised to show appropriate work zone distance.
7. The Engineer may require duplicate warning signs on the median side of divided highways where median width will permit and traffic volumes justify the signing.
8. All signs shall be constructed in accordance with the details found in the "Standard Highway Sign Designs for Texas," latest edition. Sign details not shown in this manual shall be shown in the plans or the Engineer shall provide a detail to the Contractor before the sign is manufactured.
9. The temporary traffic control devices shown in the illustrations of the BC sheets are examples. As necessary, the Engineer will determine the most appropriate traffic control devices to be used.
10. Where highway construction or maintenance work is being undertaken, other than mobile operations as defined by the Texas Manual on Uniform Traffic Control Devices, CSJ limit signs are required. CSJ limit signs are shown on BC(2). The OBEY WARNING SIGNS STATE LAW sign, STAY ALERT TALK OR TEXT LATER and the WORK ZONE TRAFFIC FINES DOUBLE sign with plaque shall be erected in advance of the CSJ limits. The BEGIN ROAD WORK NEXT X MILES, CONTRACTOR and END ROAD WORK signs shall be erected at or near the CSJ limits. For mobile operations, CSJ limit signs are not required.
11. Traffic control devices should be in place only while work is actually in progress or a definite need exists.
12. The Engineer has the final decision on the location of all traffic control devices.
13. Inactive equipment and work vehicles, including workers' private vehicles must be parked away from travel lanes. They should be as close to the right-of-way line as possible, or located behind a barrier or guardrail, or as approved by the Engineer.

WORKER SAFETY NOTES:

1. Workers on foot who are exposed to traffic or to construction equipment within the right-of-way shall wear high-visibility safety apparel meeting the requirements of ISEA "American National Standard for High-Visibility Apparel," or equivalent revisions, and labeled as ANSI 107-2004 standard performance for Class 2 or 3 risk exposure. Class 3 garments should be considered for high traffic volume work areas or night time work.
2. Except in emergency situations, flagger stations shall be illuminated when flagging is used at night.

COMPLIANT WORKZONE TRAFFIC CONTROL DEVICES

1. Only pre-qualified products shall be used. The "Compliant Work Zone Traffic Control Devices List" (CWZTCD) describes pre-qualified products and their sources.
2. Work zone traffic control devices shall be compliant with the Manual for Assessing safety Hardware (MASH).

THE DOCUMENTS BELOW CAN BE FOUND ON-LINE AT http://www.txdot.gov
COMPLIANT WORK ZONE TRAFFIC CONTROL DEVICES LIST (CWZTCD)
DEPARTMENTAL MATERIAL SPECIFICATIONS (DMS)
MATERIAL PRODUCER LIST (MPL)
ROADWAY DESIGN MANUAL - SEE "MANUALS (ONLINE MANUALS) "
STANDARD HIGHWAY SIGN DESIGNS FOR TEXAS (SHSD)
TEXAS MANUAL ON UNIFORM TRAFFIC CONTROL DEVICES (TMUTCD)
TRAFFIC ENGINEERING STANDARD SHEETS

SHEET 1 OF 12



**BARRICADE AND CONSTRUCTION
 GENERAL NOTES
 AND REQUIREMENTS**

BC (1) - 21

FILE:	bc-21.dgn	DN:	TxDOT	CK:	TxDOT	DW:	TxDOT	CK:	TxDOT
© TxDOT	November 2002	CONT	SECT	JOB	HIGHWAY				
	REVISIONS	0910	16	165	MLK JR				
4-03	7-13	DIST	COUNTY		SHEET NO.				
9-07	8-14	5-10	5-21	TYLER	SMITH	8			

DISCLAIMER: The use of this standard is governed by the "Texas Engineering Practice Act". No warranty of any kind is made by TxDOT for any purpose whatsoever. TxDOT assumes no responsibility for the conversion of this standard to other formats or for incorrect results or damages resulting from its use.

TYPICAL LOCATION OF CROSSROAD SIGNS

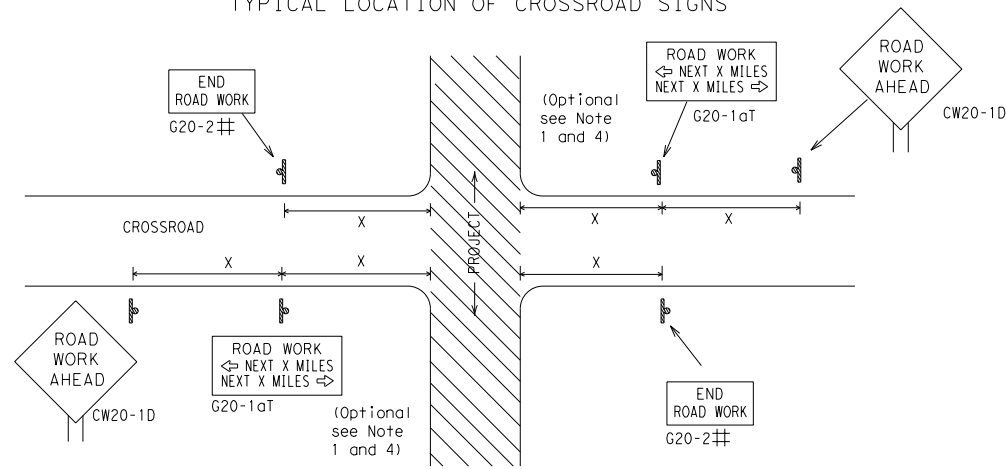

- ## May be mounted on back of "ROAD WORK AHEAD" (CW20-1D) sign with approval of Engineer. (See note 2 below)
- The typical minimum signing on a crossroad approach should be a "ROAD WORK AHEAD" (CW20-1D) sign and a (G20-2) "END ROAD WORK" sign, unless noted otherwise in plans.
 - The Engineer may use the reduced size 36" x 36" ROAD WORK AHEAD (CW20-1D) sign mounted back to back with the reduced size 36" x 18" "END ROAD WORK" (G20-2) sign on low volume crossroads (see Note 4 under "Typical Construction Warning Sign Size and Spacing"). See the "Standard Highway Sign Designs for Texas" manual for sign details. The Engineer may omit the advance warning signs on low volume crossroads. The Engineer will determine whether a road is low volume as per TMUTCD Part 5. This information shall be shown in the plans.
 - Based on existing field conditions, the Engineer/Inspector may require additional signs such as FLAGGER AHEAD, LOOSE GRAVEL, or other appropriate signs. When additional signs are required, these signs will be considered part of the minimum requirements. The Engineer/Inspector will determine the proper location and spacing of any sign not shown on the BC sheets, Traffic Control Plan sheets or the Work Zone Standard Sheets.
 - The "ROAD WORK NEXT X MILES" (G20-1aT) sign shall be required at high volume crossroads to advise motorists of the length of construction in either direction from the intersection. The Engineer will determine whether a roadway is considered high volume.
 - Additional traffic control devices may be shown elsewhere in the plans for higher volume crossroads.
 - When work occurs in the intersection area, appropriate traffic control devices, as shown elsewhere in the plans or as determined by the Engineer/Inspector, shall be in place.

T-INTERSECTION

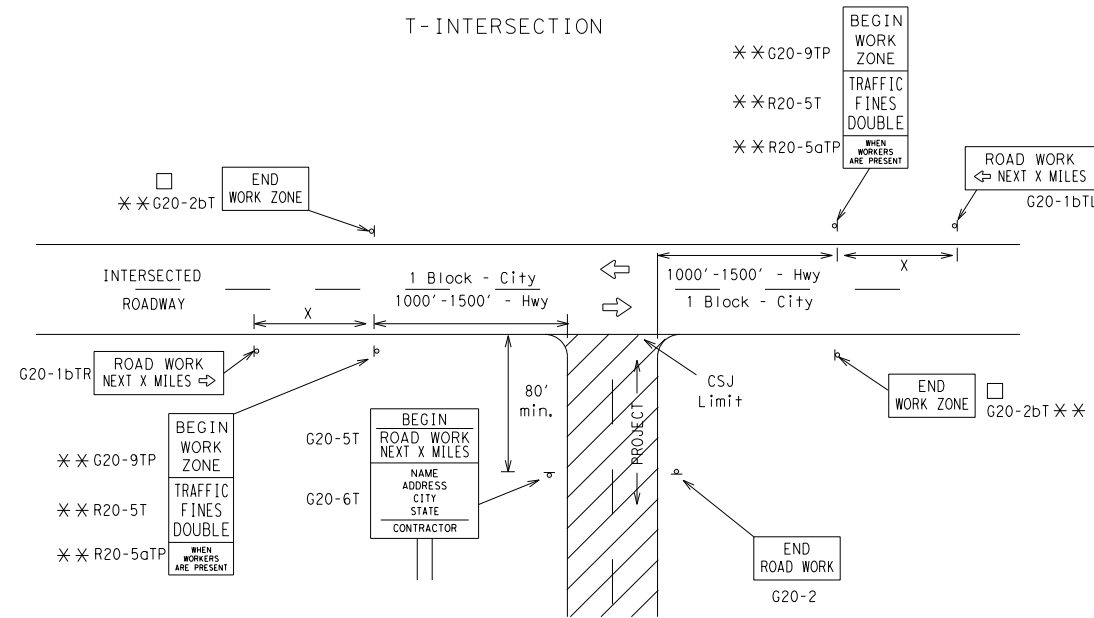

CSJ LIMITS AT T-INTERSECTION

- The Engineer will determine the types and location of any additional traffic control devices, such as a flagger and accompanying signs, or other signs, that should be used when work is being performed at or near an intersection.
- If construction closes the road at a T-intersection, the Contractor shall place the "CONTRACTOR NAME" (G20-6T) sign behind the Type 3 Barricades for the road closure (see BC(10) also). The "ROAD WORK NEXT X MILES" left arrow (G20-1bTL) and "ROAD WORK NEXT X MILES" right arrow (G20-1bTR) signs shall be replaced by the detour signing called for in the plans.

TYPICAL CONSTRUCTION WARNING SIGN SIZE AND SPACING^{1,5,6}

Sign Number or Series	SIZE		SPACING	
	Conventional Road	Expressway/Freeway	Posted Speed MPH	Sign Δ Spacing "x" Feet (Apprx.)
CW20 ⁴	48" x 48"	48" x 48"	30	120
CW21			35	160
CW22			40	240
CW23			45	320
CW25			50	400
CW1, CW2, CW7, CW8, CW9, CW11, CW14	36" x 36"	48" x 48"	55	500 ²
CW3, CW4, CW5, CW6, CW8-3, CW10, CW12	48" x 48"	48" x 48"	60	600 ²
			65	700 ²
			70	800 ²
			75	900 ²
			80	1000 ²
			*	* ³

* For typical sign spacings on divided highways, expressways and freeways, see Part 6 of the "Texas Manual on Uniform Traffic Control Devices" (TMUTCD) typical application diagrams or TCP Standard Sheets.

Δ Minimum distance from work area to first Advance Warning sign nearest the work area and/or distance between each additional sign.

GENERAL NOTES

- Special or larger size signs may be used as necessary.
- Distance between signs should be increased as required to have 1500 feet advance warning.
- Distance between signs should be increased as required to have 1/2 mile or more advance warning.
- 36" x 36" "ROAD WORK AHEAD" (CW20-1D) signs may be used on low volume crossroads at the discretion of the Engineer as per TMUTCD Part 5. See Note 2 under "Typical Location of Crossroad Signs".
- Only diamond shaped warning sign sizes are indicated.
- See sign size listing in "TMUTCD", Sign Appendix or the "Standard Highway Sign Designs for Texas" manual for complete list of available sign design sizes.

WORK AREAS IN MULTIPLE LOCATIONS WITHIN CSJ LIMITS

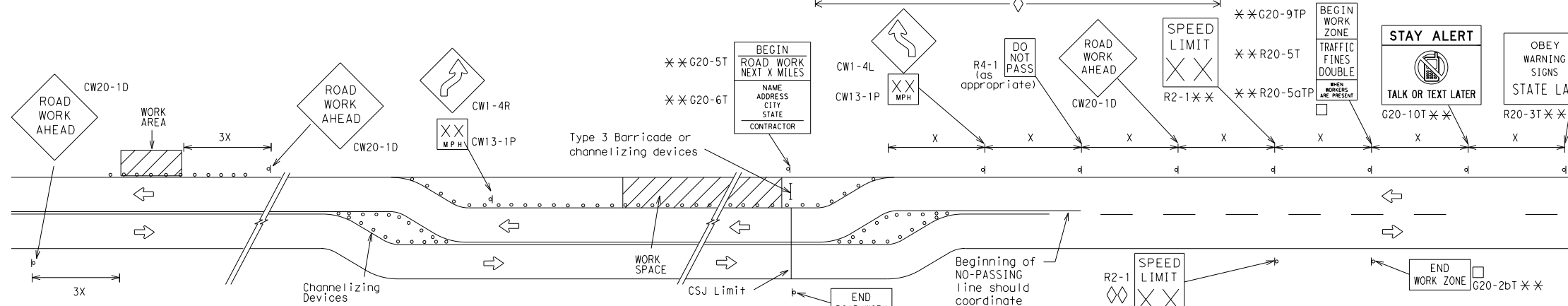

When extended distances occur between minimal work spaces, the Engineer/Inspector should ensure additional "ROAD WORK AHEAD" (CW20-1D) signs are placed in advance of these work areas to remind drivers they are still within the project limits. See the applicable TCP sheets for exact location and spacing of signs and channelizing devices.

SAMPLE LAYOUT OF SIGNING FOR WORK BEGINNING DOWNSTREAM OF THE CSJ LIMITS

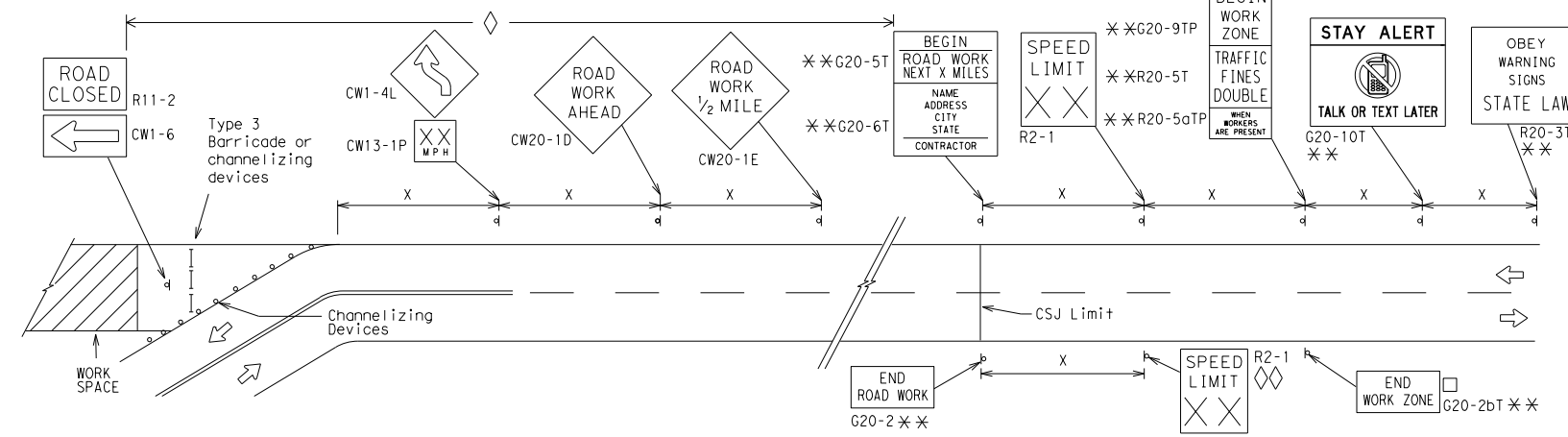

SAMPLE LAYOUT OF SIGNING FOR WORK BEGINNING AT THE CSJ LIMITS

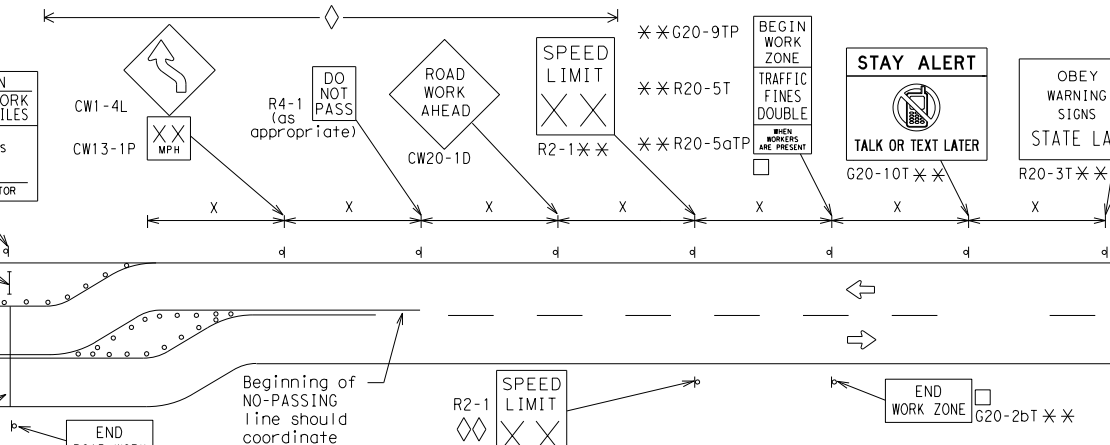

NOTES

- The Contractor shall determine the appropriate distance to be placed on the G20-1 series signs and "BEGIN ROAD WORK NEXT X MILES" (G20-5T) sign for each specific project. This distance shall replace the "x" and shall be rounded to the nearest whole mile with the approval of the Engineer. No decimals shall be used.
- The "BEGIN WORK ZONE" (G20-9TP) and "END WORK ZONE" (G20-2bT) shall be used as shown on the sample layout when advance signs are required outside the CSJ Limits. They inform the motorist of entering or leaving a part of the work zone lying outside the CSJ Limits where traffic fines may double if workers are present.
- CSJ limit signing is required for highway construction and maintenance work, with the exception of mobile operations.
- Area for placement of "ROAD WORK AHEAD" (CW20-1D) sign and other signs or devices as called for on the Traffic Control Plan.
- Contractor will install a regulatory speed limit sign at the end of the work zone.

LEGEND	
—	Type 3 Barricade
○ ○ ○	Channelizing Devices
■	Sign
X	See Typical Construction Warning Sign Size and Spacing chart or the TMUTCD for sign spacing requirements.

SHEET 2 OF 12



BARRICADE AND CONSTRUCTION PROJECT LIMIT

BC(2)-21

FILE: bc-21.dgn	DN: TxDOT	CK: TxDOT	DW: TxDOT	CK: TxDOT
© TxDOT November 2002	CONT	SECT	JOB	HIGHWAY
REVISIONS	0910	16	165	MLK JR
9-07 8-14	DIST	COUNTY		SHEET NO.
7-13 5-21	TYLER	SMITH		9

DATE: FILE:

TYPICAL APPLICATION OF WORK ZONE SPEED LIMIT SIGNS

Work zone speed limits shall be regulatory, established in accordance with the "Procedures for Establishing Speed Zones," and approved by the Texas Transportation Commission, or by City Ordinance when within Incorporated City Limits.

Reduced speeds should only be posted in the vicinity of work activity and not throughout the entire project. Regulatory work zone speed signs (R2-1) shall be removed or covered during periods when they are not needed.

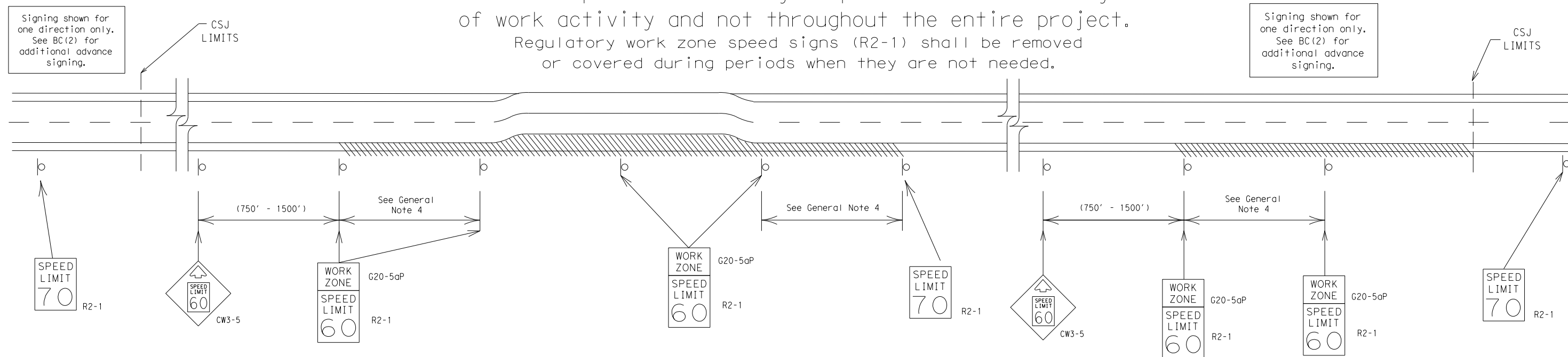

GUIDANCE FOR USE:

LONG/INTERMEDIATE TERM WORK ZONE SPEED LIMITS

This type of work zone speed limit should be included on the design of the traffic control plans when restricted geometrics with a lower design speed are present in the work zone and modification of the geometrics to a higher design speed is not feasible.

Long/Intermediate Term Work Zone Speed Limit signs, when approved as described above, should be posted and visible to the motorist when work activity is present. Work activity may also be defined as a change in the roadway that requires a reduced speed for motorists to safely negotiate the work area, including:

- rough road or damaged pavement surface
- substantial alteration of roadway geometrics (diversions)
- construction detours
- grade
- width
- other conditions readily apparent to the driver

As long as any of these conditions exist, the work zone speed limit signs should remain in place.

SHORT TERM WORK ZONE SPEED LIMITS

This type of work zone speed limit may be included on the design of the traffic control plans when workers or equipment are not behind concrete barrier, when work activity is within 10 feet of the traveled way or actually in the traveled way.

Short Term Work Zone Speed Limit signs should be posted and visible to the motorists only when work activity is present. When work activity is not present, signs shall be removed or covered. (See Removing or Covering on BC(4)).

GENERAL NOTES

- Regulatory work zone speed limits should be used only for sections of construction projects where speed control is of major importance.
- Regulatory work zone speed limit signs shall be placed on supports at a 7 foot minimum mounting height.
- Speed zone signs are illustrated for one direction of travel and are normally posted for each direction of travel.
- Frequency of work zone speed limit signs should be:

40 mph and greater	0.2 to 2 miles
35 mph and less	0.2 to 1 mile
- Regulatory speed limit signs shall have black legend and border on a white reflective background (See "Reflective Sheeting" on BC(4)).
- Fabrication, erection and maintenance of the "ADVANCE SPEED LIMIT" (CW3-5) sign, "WORK ZONE" (G20-5aP) plaque and the "SPEED LIMIT" (R2-1) signs shall not be paid for directly, but shall be considered subsidiary to Item 502.
- Turning signs from view, laying signs over or down will not be allowed, unless as otherwise noted under "REMOVING OR COVERING" on BC(4).
- Techniques that may help reduce traffic speeds include but are not limited to:
 - Law enforcement.
 - Flagger stationed next to sign.
 - Portable changeable message sign (PCMS).
 - Low-power (drone) radar transmitter.
 - Speed monitor trailers or signs.
- Speeds shown on details above are for illustration only. Work Zone Speed Limits should only be posted as approved for each project.
- For more specific guidance concerning the type of work, work zone conditions and factors impacting allowable regulatory construction speed zone reduction see TxDOT form #1204 in the TxDOT e-form system.

DISCLAIMER: The use of this standard is governed by the "Texas Engineering Practice Act". No warranty of any kind is made by TxDOT for any purpose whatsoever. TxDOT assumes no responsibility for the conversion of this standard to other formats or for incorrect results or damages resulting from its use.

DATE:
FILE:

SHEET 3 OF 12



BARRICADE AND CONSTRUCTION WORK ZONE SPEED LIMIT

BC (3) - 21

FILE:	bc-21.dgn	DN: TxDOT	CK: TxDOT	DW: TxDOT	CK: TxDOT
© TxDOT	November 2002	CONT	SECT	JOB	HIGHWAY
REVISIONS		0910	16	165	MLK JR
9-07	8-14	DIST	COUNTY	SHEET NO.	
7-13	5-21	TYLER	SMITH	10	

DISCLAIMER: The use of this standard is governed by the "Texas Engineering Practice Act". No warranty of any kind is made by TxDOT for any purpose whatsoever. TxDOT assumes no responsibility for the conversion of this standard to other formats or for incorrect results or damages resulting from its use.

TYPICAL MINIMUM CLEARANCES FOR LONG TERM AND INTERMEDIATE TERM SIGNS

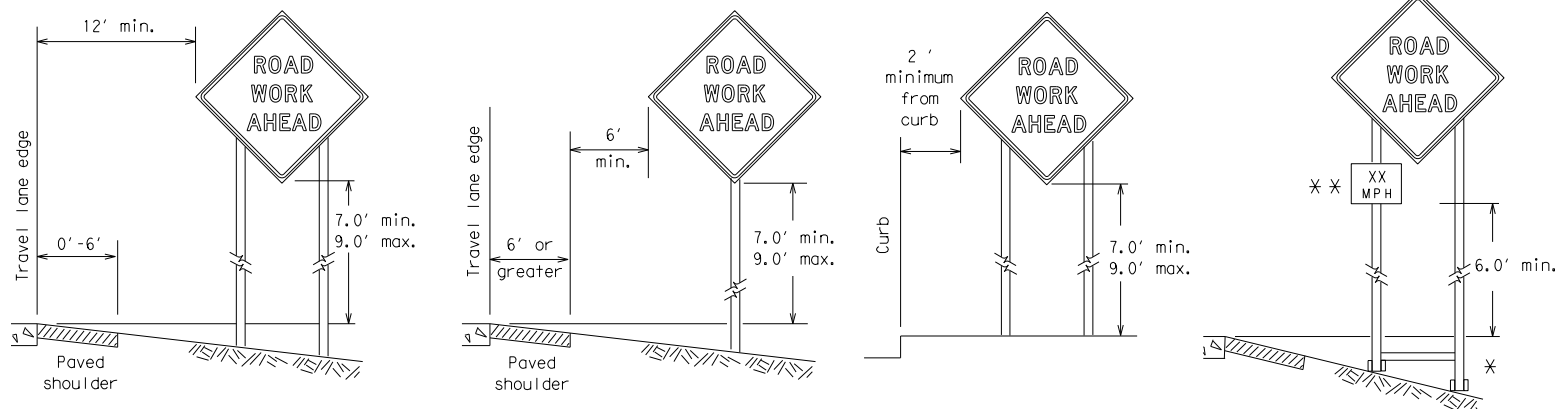

* When placing skid supports on unlevel ground, the leg post lengths must be adjusted so the sign appears straight and plumb. Objects shall NOT be placed under skids as a means of leveling.

** When plaques are placed on dual-leg supports, they should be attached to the upright nearest the travel lane. Supplemental plaques (advisory or distance) should not cover the surface of the parent sign.

ATTACHMENT FOR SIGN SUPPORTS

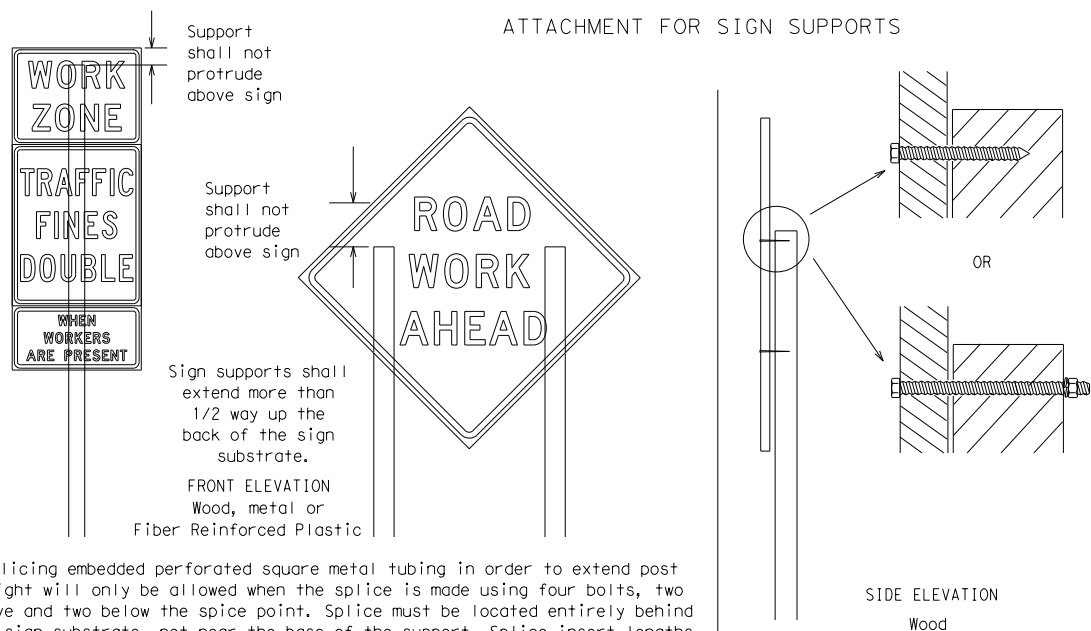

Splicing embedded perforated square metal tubing in order to extend post height will only be allowed when the splice is made using four bolts, two above and two below the splice point. Splice must be located entirely behind the sign substrate, not near the base of the support. Splice insert lengths should be at least 5 times nominal post size, centered on the splice and of at least the same gauge material.

GENERAL NOTES FOR WORK ZONE SIGNS

- Contractor shall install and maintain signs in a straight and plumb condition and/or as directed by the Engineer.
- Wooden sign posts shall be painted white.
- Barricades shall NOT be used as sign supports.
- All signs shall be installed in accordance with the plans or as directed by the Engineer. Signs shall be used to regulate, warn, and guide the traveling public safely through the work zone.
- The Contractor may furnish either the sign design shown in the plans or in the "Standard Highway Sign Designs for Texas" (SHSD). The Engineer/Inspector may require the Contractor to furnish other work zone signs that are shown in the TMUTCD but may have been omitted from the plans. Any variation in the plans shall be documented by written agreement between the Engineer and the Contractor's Responsible Person. All changes must be documented in writing before being implemented. This can include documenting the changes in the Inspector's TxDOT diary and having both the Inspector and Contractor initial and date the agreed upon changes.
- The Contractor shall furnish sign supports listed in the "Compliant Work Zone Traffic Control Device List" (CWZTCD) for small roadside signs. Supports for temporary large roadside signs shall meet the requirements detailed on the Temporary Large Roadside Signs (TLRS) standard sheets. The Contractor shall install the sign support in accordance with the manufacturer's recommendations. If there is a question regarding installation procedures, the Contractor shall furnish the Engineer a copy of the manufacturer's installation recommendations so the Engineer can verify the correct procedures are being followed.
- The Contractor is responsible for installing signs on approved supports and replacing signs with damaged or cracked substrates and/or damaged or marred reflective sheeting as directed by the Engineer/Inspector.
- Identification markings may be shown only on the back of the sign substrate. The maximum height of letters and/or company logos used for identification shall be 1 inch.
- The Contractor shall replace damaged wood posts. New or damaged wood sign posts shall not be spliced.

DURATION OF WORK (as defined by the "Texas Manual on Uniform Traffic Control Devices" Part 6)

- The types of sign supports, sign mounting height, the size of signs, and the type of sign substrates can vary based on the type of work being performed. The Engineer is responsible for selecting the appropriate size sign for the type of work being performed. The Contractor is responsible for ensuring the sign support, sign mounting height and substrate meets manufacturer's recommendations in regard to crashworthiness and duration of work requirements.
 - Long-term stationary - work that occupies a location more than 3 days.
 - Intermediate-term stationary - work that occupies a location more than one daylight period up to 3 days, or nighttime work lasting more than one hour.
 - Short-term stationary - daytime work that occupies a location for more than 1 hour in a single daylight period.
 - Short, duration - work that occupies a location up to 1 hour.
 - Mobile - work that moves continuously or intermittently (stopping for up to approximately 15 minutes.)

SIGN MOUNTING HEIGHT

- The bottom of Long-term/Intermediate-term signs shall be at least 7 feet, but not more than 9 feet, above the paved surface, except as shown for supplemental plaques mounted below other signs.
- The bottom of Short-term/Short Duration signs shall be a minimum of 1 foot above the pavement surface but no more than 2 feet above the ground.
- Long-term/Intermediate-term Signs may be used in lieu of Short-term/Short Duration signing.
- Short-term/Short Duration signs shall be used only during daylight and shall be removed at the end of the workday or raised to appropriate Long-term/Intermediate sign height.
- Regulatory signs shall be mounted at least 7 feet, but not more than 9 feet, above the paved surface regardless of work duration.

SIZE OF SIGNS

- The Contractor shall furnish the sign sizes shown on BC (2) unless otherwise shown in the plans or as directed by the Engineer.

SIGN SUBSTRATES

- The Contractor shall ensure the sign substrate is installed in accordance with the manufacturer's recommendations for the type of sign support that is being used. The CWZTCD lists each substrate that can be used on the different types and models of sign supports.
- "Mesh" type materials are NOT an approved sign substrate, regardless of the tightness of the weave.
- All wooden individual sign panels fabricated from 2 or more pieces shall have one or more plywood cleat, 1/2" thick by 6" wide, fastened to the back of the sign and extending fully across the sign. The cleat shall be attached to the back of the sign using wood screws that do not penetrate the face of the sign panel. The screws shall be placed on both sides of the splice and spaced at 6" centers. The Engineer may approve other methods of splicing the sign face.

REFLECTIVE SHEETING

- All signs shall be retroreflective and constructed of sheeting meeting the color and retro-reflectivity requirements of DMS-8300 for rigid signs or DMS-8310 for roll-up signs. The web address for DMS specifications is shown on BC(1).
- White sheeting, meeting the requirements of DMS-8300 Type A, shall be used for signs with a white background.
- Orange sheeting, meeting the requirements of DMS-8300 Type B_{FL} or Type C_{FL}, shall be used for rigid signs with orange backgrounds.

SIGN LETTERS

- All sign letters and numbers shall be clear, and open rounded type uppercase alphabet letters as approved by the Federal Highway Administration (FHWA) and as published in the "Standard Highway Sign Design for Texas" manual. Signs, letters and numbers shall be of first class workmanship in accordance with Department Standards and Specifications.

REMOVING OR COVERING

- When sign messages may be confusing or do not apply, the signs shall be removed or completely covered.
- Long-term stationary or intermediate stationary signs installed on square metal tubing may be turned away from traffic 90 degrees when the sign message is not applicable. This technique may not be used for signs installed in the median of divided highways or near any intersections where the sign may be seen from approaching traffic.
- Signs installed on wooden skids shall not be turned at 90 degree angles to the roadway. These signs should be removed or completely covered when not required.
- When signs are covered, the material used shall be opaque, such as heavy mil black plastic, or other materials which will cover the entire sign face and maintain their opaque properties under automobile headlights at night, without damaging the sign sheeting.
- Burlap shall NOT be used to cover signs.
- Duct tape or other adhesive material shall NOT be affixed to a sign face.
- Signs and anchor stubs shall be removed and holes backfilled upon completion of work.

SIGN SUPPORT WEIGHTS

- Where sign supports require the use of weights to keep from turning over, the use of sandbags with dry, cohesionless sand should be used.
- The sandbags will be tied shut to keep the sand from spilling and to maintain a constant weight.
- Rock, concrete, iron, steel or other solid objects shall not be permitted for use as sign support weights.
- Sandbags should weigh a minimum of 35 lbs and a maximum of 50 lbs.
- Sandbags shall be made of a durable material that tears upon vehicular impact. Rubber (such as tire inner tubes) shall NOT be used.
- Rubber ballasts designed for channelizing devices should not be used for ballast on portable sign supports. Sign supports designed and manufactured with rubber bases may be used when shown on the CWZTCD list.
- Sandbags shall only be placed along or laid over the base supports of the traffic control device and shall not be suspended above ground level or hung with rope, wire, chains or other fasteners. Sandbags shall be placed along the length of the skids to weigh down the sign support.
- Sandbags shall NOT be placed under the skid and shall not be used to level sign supports placed on slopes.

FLAGS ON SIGNS

- Flags may be used to draw attention to warning signs. When used, the flag shall be 16 inches square or larger and shall be orange or fluorescent red-orange in color. Flags shall not be allowed to cover any portion of the sign face.

STOP/SLOW PADDLES

- STOP/SLOW paddles are the primary method to control traffic by flaggers. The STOP/SLOW paddle size should be 24" x 24".
- STOP/SLOW paddles shall be retroreflectORIZED when used at night.
- STOP/SLOW paddles may be attached to a staff with a minimum length of 6' to the bottom of the sign.
- Any lights incorporated into the STOP or SLOW paddle faces shall only be as specifically described in Section 6E.03 Hand Signaling Devices in the TMUTCD.

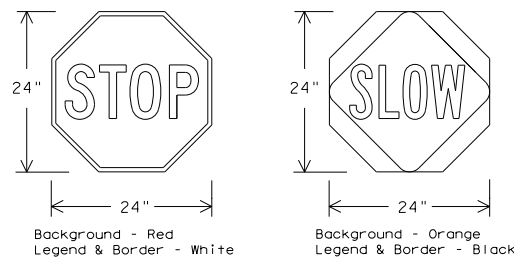

SHEETING REQUIREMENTS (WHEN USED AT NIGHT)		
USAGE	COLOR	SIGN FACE MATERIAL
BACKGROUND	RED	TYPE B OR C SHEETING
BACKGROUND	ORANGE	TYPE B _{FL} OR C _{FL} SHEETING
LEGEND & BORDER	WHITE	TYPE B OR C SHEETING
LEGEND & BORDER	BLACK	ACRYLIC NON-REFLECTIVE FILM

CONTRACTOR REQUIREMENTS FOR MAINTAINING PERMANENT SIGNS WITHIN THE PROJECT LIMITS

- Permanent signs are used to give notice of traffic laws or regulations, call attention to conditions that are potentially hazardous to traffic operations, show route designations, destinations, directions, distances, services, points of interest, and other geographical, recreational, specific service (LOGO), or cultural information. Drivers proceeding through a work zone need the same, if not better route guidance as normally installed on a roadway without construction.
- When permanent regulatory or warning signs conflict with work zone conditions, remove or cover the permanent signs until the permanent sign message matches the roadway condition. For details for covering large guide signs see the TS-CD standard.
- When existing permanent signs are moved and relocated due to construction purposes, they shall be visible to motorists at all times.
- If existing signs are to be relocated on their original supports, they shall be installed on crashworthy bases as shown on the SMD Standard sheets. The signs shall meet the required mounting heights shown on the BC Sheets or the SMD Standards. This work should be paid for under the appropriate pay item for relocating existing signs.
- If permanent signs are to be removed and relocated using temporary supports, the Contractor shall use crashworthy supports as shown on the BC standard sheets, TLRS standard sheets or the CWZTCD list. The signs shall meet the required mounting heights shown on the BC, or the SMD standard sheets during construction. This work should be paid for under the appropriate pay item for relocating existing signs.
- Any sign or traffic control device that is struck or damaged by the Contractor or his/her construction equipment shall be replaced as soon as possible by the Contractor to ensure proper guidance for the motorists. This will be subsidiary to Item 502.

SHEET 4 OF 12



BARRICADE AND CONSTRUCTION TEMPORARY SIGN NOTES

BC (4) - 21

FILE:	bc-21.dgn	DN:	TxDOT	CK:	TxDOT	DW:	TxDOT	CK:	TxDOT
© TxDOT	November 2002	CONT	SECT	JOB	HIGHWAY				
REVISIONS		0910	16	165	MLK JR				
9-07	8-14	DIST	COUNTY	SHEET NO.					
7-13	5-21	TYLER	SMITH	11					

DATE:
FILE:

DISCLAIMER: The use of this standard is governed by the "Texas Engineering Practice Act". No warranty of any kind is made by TxDOT for any purpose whatsoever. TxDOT assumes no responsibility for the conversion of this standard to other formats or for incorrect results or damages resulting from its use.

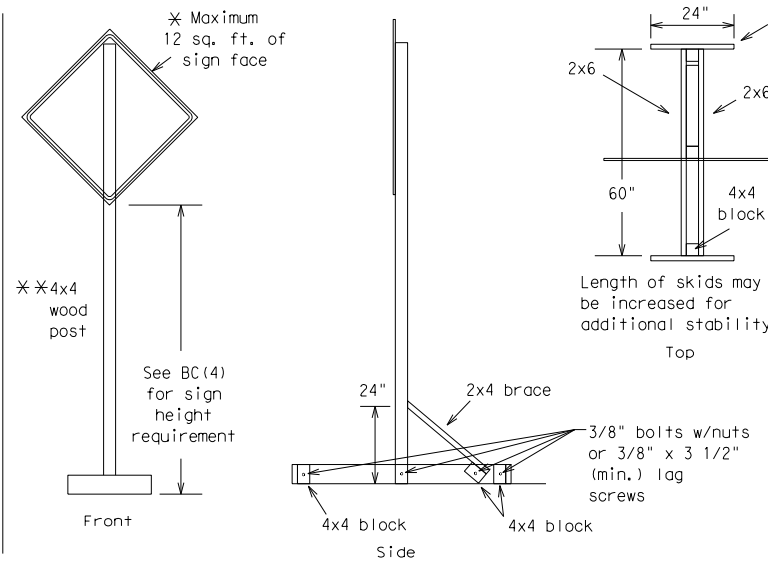
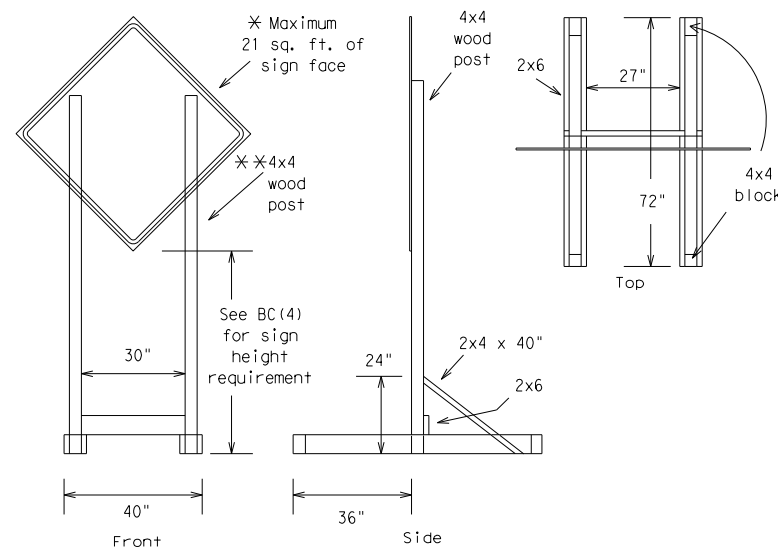

SKID MOUNTED WOOD SIGN SUPPORTS

* LONG/INTERMEDIATE TERM STATIONARY - PORTABLE SKID MOUNTED SIGN SUPPORTS

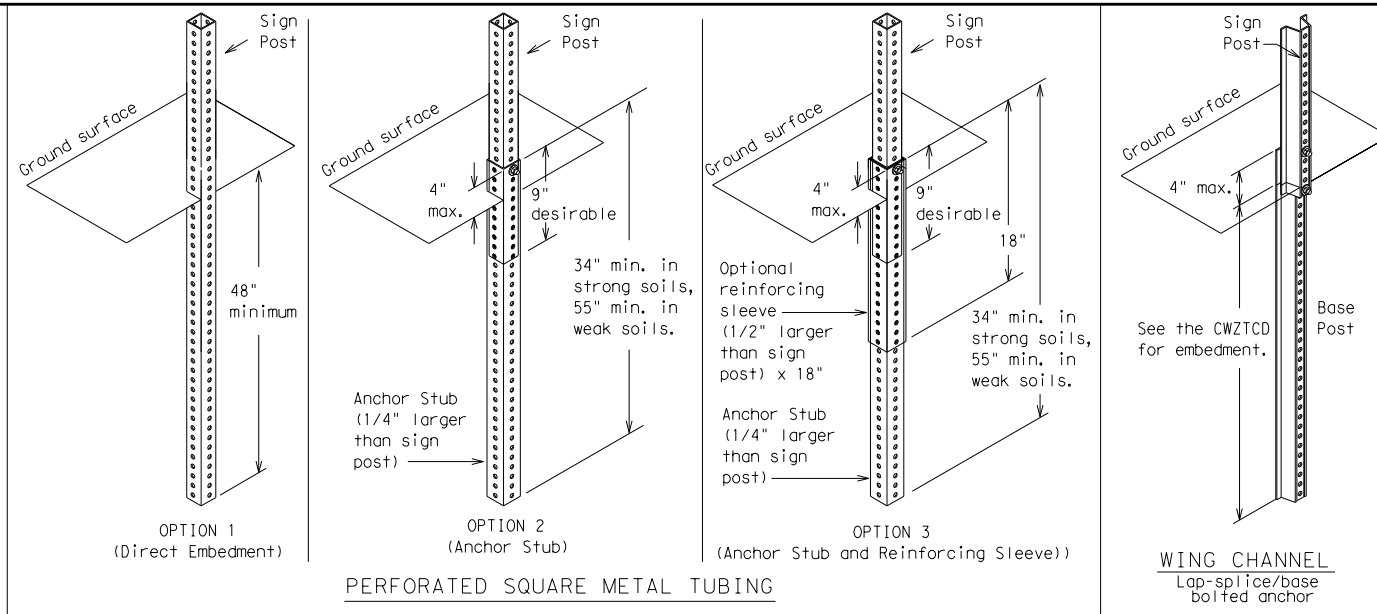

GROUND MOUNTED SIGN SUPPORTS

Refer to the CWZTCD and the manufacturer's installation procedure for each type sign support. The maximum sign square footage shall adhere to the manufacturer's recommendation. Two post installations can be used for larger signs.

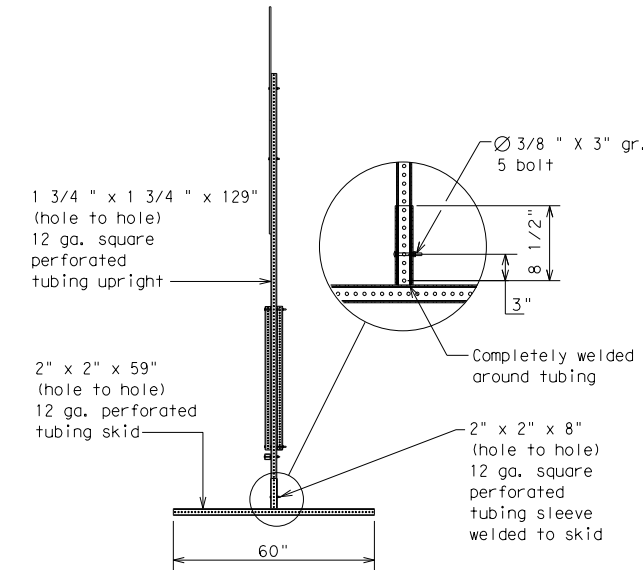
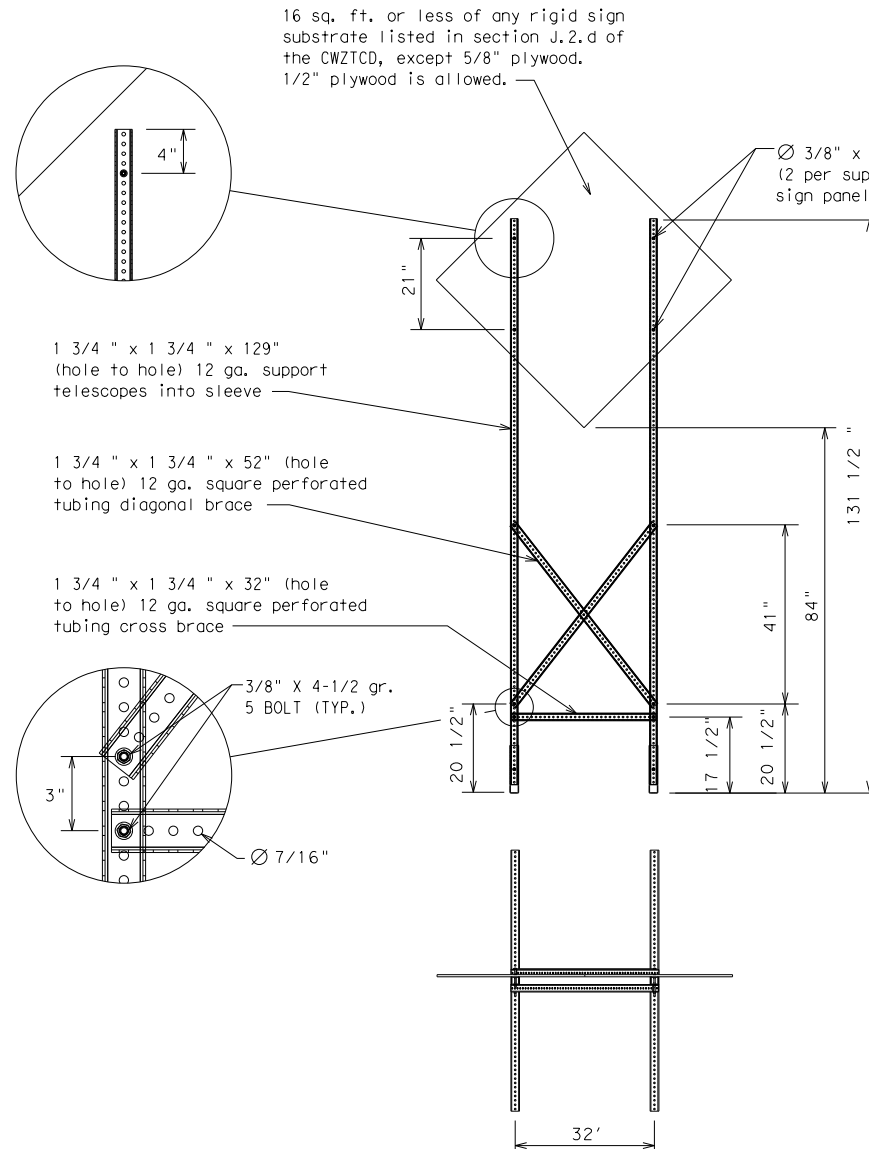
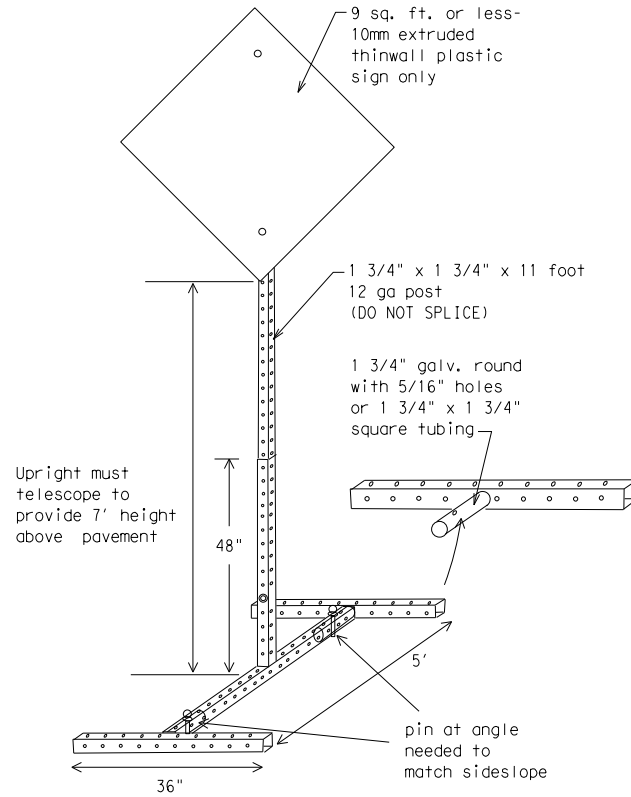

SKID MOUNTED PERFORATED SQUARE STEEL TUBING SIGN SUPPORTS

* LONG/INTERMEDIATE TERM STATIONARY - PORTABLE SKID MOUNTED SIGN SUPPORTS

WEDGE ANCHORS

Both steel and plastic Wedge Anchor Systems as shown on the SMD Standard Sheets may be used as temporary sign supports for signs up to 10 square feet of sign face. They may be set in concrete or in sturdy soils if approved by the Engineer. (See web address for "Traffic Engineering Standard Sheets" on BC(1)).

OTHER DESIGNS

MORE DETAILS OF APPROVED LONG/INTERMEDIATE AND SHORT TERM SUPPORTS CAN BE FOUND ON THE CWZTCD LIST. SEE BC(1) FOR WEBSITE LOCATION.

GENERAL NOTES

- Nails may be used in the assembly of wooden sign supports, but 3/8" bolts with nuts or 3/8" x 3 1/2" lag screws must be used on every joint for final connection.
- No more than 2 sign posts shall be placed within a 7 ft. circle, except for specific materials noted on the CWZTCD List.
- When project is completed, all sign supports and foundations shall be removed from the project site. This will be considered subsidiary to Item 502.

- * See BC(4) for definition of "Work Duration."
- ** Wood sign posts MUST be one piece. Splicing will NOT be allowed. Posts shall be painted white.
- See the CWZTCD for the type of sign substrate that can be used for each approved sign support.

SHEET 5 OF 12



BARRICADE AND CONSTRUCTION TYPICAL SIGN SUPPORT

BC(5) - 21

FILE: bc-21.dgn	DN: TxDOT	CK: TxDOT	DW: TxDOT	CK: TxDOT
© TxDOT November 2002	CONT	SECT	JOB	HIGHWAY
REVISIONS	0910	16	165	MLK JR
9-07 8-14	DIST	COUNTY	SHEET NO.	
7-13 5-21	TYLER	SMITH	12	

DATE: DATE TIME
FILE: DOCUMENT NAME

WHEN NOT IN USE, REMOVE THE PCMS FROM THE RIGHT-OF-WAY OR PLACE THE PCMS BEHIND BARRIER OR GUARDRAIL WITH SIGN PANEL TURNED PARALLEL TO TRAFFIC

RECOMMENDED PHASES AND FORMATS FOR PCMS MESSAGES DURING ROADWORK ACTIVITIES

(The Engineer may approve other messages not specifically covered here.)

PORTABLE CHANGEABLE MESSAGE SIGNS

- The Engineer/Inspector shall approve all messages used on portable changeable message signs (PCMS).
- Messages on PCMS should contain no more than 8 words (about four to eight characters per word), not including simple words such as "TO," "FOR," "AT," etc.
- Messages should consist of a single phase, or two phases that alternate. Three-phase messages are not allowed. Each phase of the message should convey a single thought, and must be understood by itself.
- Use the word "EXIT" to refer to an exit ramp on a freeway; i.e., "EXIT CLOSED." Do not use the term "RAMP."
- Always use the route or interstate designation (IH, US, SH, FM) along with the number when referring to a roadway.
- When in use, the bottom of a stationary PCMS message panel should be a minimum 7 feet above the roadway, where possible.
- The message term "WEEKEND" should be used only if the work is to start on Saturday morning and end by Sunday evening at midnight. Actual days and hours of work should be displayed on the PCMS if work is to begin on Friday evening and/or continue into Monday morning.
- The Engineer/Inspector may select one of two options which are available for displaying a two-phase message on a PCMS. Each phase may be displayed for either four seconds each or for three seconds each.
- Do not "flash" messages or words included in a message. The message should be steady burn or continuous while displayed.
- Do not present redundant information on a two-phase message; i.e., keeping two lines of the message the same and changing the third line.
- Do not use the word "Danger" in message.
- Do not display the message "LANES SHIFT LEFT" or "LANES SHIFT RIGHT" on a PCMS. Drivers do not understand the message.
- Do not display messages that scroll horizontally or vertically across the face of the sign.
- The following table lists abbreviated words and two-word phrases that are acceptable for use on a PCMS. Both words in a phrase must be displayed together. Words or phrases not on this list should not be abbreviated, unless shown in the TMUTCD.
- PCMS character height should be at least 18 inches for trailer mounted units. They should be visible from at least 1/2 (.5) mile and the text should be legible from at least 600 feet at night and 800 feet in daylight. Truck mounted units must have a character height of 10 inches and must be legible from at least 400 feet.
- Each line of text should be centered on the message board rather than left or right justified.
- If disabled, the PCMS should default to an illegible display that will not alarm motorists and will only be used to alert workers that the PCMS has malfunctioned. A pattern such as a series of horizontal solid bars is appropriate.

DISCLAIMER: The use of this standard is governed by the "Texas Engineering Practice Act." No warranty of any kind is made by TxDOT for any purpose whatsoever. TxDOT assumes no responsibility for the conversion of this standard to other formats or for incorrect results or damages resulting from its use.

Phase 1: Condition Lists

Road/Lane/Ramp Closure List

FREEWAY CLOSED X MILE
ROAD CLOSED AT SH XXX
ROAD CLSD AT FM XXXX
RIGHT X LANES CLOSED
CENTER LANE CLOSED
NIGHT LANE CLOSURES
VARIOUS LANES CLOSED
EXIT CLOSED
MALL DRIVEWAY CLOSED
XXXXXXXX BLVD CLOSED

Other Condition List

FRONTAGE ROAD CLOSED
SHOULDER CLOSED XXX FT
RIGHT LN CLOSED XXX FT
RIGHT X LANES OPEN
DAYTIME LANE CLOSURES
I-XX SOUTH EXIT CLOSED
EXIT XXX CLOSED X MILE
RIGHT LN TO BE CLOSED
X LANES CLOSED TUE - FRI
ROADWORK XXX FT
FLAGGER XXXX FT
RIGHT LN NARROWS XXXX FT
MERGING TRAFFIC XXXX FT
LOOSE GRAVEL XXXX FT
DETOUR X MILE
ROADWORK PAST SH XXXX
BUMP XXXX FT
TRAFFIC SIGNAL XXXX FT
ROAD REPAIRS XXXX FT
LANE NARROWS XXXX FT
TWO-WAY TRAFFIC XX MILE
CONST TRAFFIC XXX FT
UNEVEN LANES XXXX FT
ROUGH ROAD XXXX FT
ROADWORK NEXT FRI-SUN
US XXX EXIT X MILES
LANES SHIFT *

* LANES SHIFT in Phase 1 must be used with STAY IN LANE in Phase 2.

Phase 2: Possible Component Lists

Action to Take/Effect on Travel List

MERGE RIGHT
DETOUR NEXT X EXITS
USE EXIT XXX
STAY ON US XXX SOUTH
TRUCKS USE US XXX N
WATCH FOR TRUCKS
EXPECT DELAYS
REDUCE SPEED XXX FT
USE OTHER ROUTES
STAY IN LANE *
FORM X LINES RIGHT
USE XXXXX RD EXIT
USE EXIT I-XX NORTH
USE I-XX E TO I-XX N
WATCH FOR TRUCKS
EXPECT DELAYS
END SHOULDER USE
WATCH FOR WORKERS

Location List

AT FM XXXX
BEFORE RAILROAD CROSSING
NEXT X MILES
PAST US XXX EXIT
XXXXXXXX TO XXXXXXX
US XXX TO FM XXXX

Warning List

SPEED LIMIT XX MPH
MAXIMUM SPEED XX MPH
MINIMUM SPEED XX MPH
ADVISORY SPEED XX MPH
RIGHT LANE EXIT
USE CAUTION
DRIVE SAFELY
DRIVE WITH CARE

** Advance Notice List

TUE-FRI XX AM-X PM
APR XX-XX X PM-X AM
BEGINS MONDAY
BEGINS MAY XX
MAY X-X XX PM - XX AM
NEXT FRI-SUN
XX AM TO XX PM
NEXT TUE AUG XX
TONIGHT XX PM-XX AM

** See Application Guidelines Note 6.

WORD OR PHRASE	ABBREVIATION	WORD OR PHRASE	ABBREVIATION
Access Road	ACCS RD	Major	MAJ
Alternate	ALT	Miles	MI
Avenue	AVE	Miles Per Hour	MPH
Best Route	BEST RTE	Minor	MNR
Boulevard	BLVD	Monday	MON
Bridge	BRDG	Normal	NORM
Canal	CANT	North	N
Center	CTR	Northbound	(route) N
Construction Ahead	CONST AHD	Parking	PKING
CROSSING	XING	Road	RD
Detour Route	DETOUR RTE	Right Lane	RT LN
Do Not	DONT	Saturday	SAT
East	E	Service Road	SERV RD
Eastbound	(route) E	Shoulder	SHLDR
Emergency	EMER	Slippery	SLIP
Emergency Vehicle	EMER VEH	South	S
Entrance, Enter	ENT	Southbound	(route) S
Express Lane	EXP LN	Speed	SPD
Expressway	EXPWY	Street	ST
XXXX Feet	XXXX FT	Sunday	SUN
Fog Ahead	FOG AHD	Telephone	PHONE
Freeway	FRWY, FWY	Temporary	TEMP
Freeway Blocked	FWY BLKD	Thursday	THURS
Friday	FRI	To Downtown	TO DWNTN
Hazardous Driving	HAZ DRIVING	Traffic	TRAF
Hazardous Material	HAZMAT	Travelers	TRVLR
High-Occupancy Vehicle	HOV	Tuesday	TUES
Highway	HWY	Time Minutes	TIME MIN
Hour(s)	HR, HRS	Upper Level	UPR LEVEL
Information	INFO	Vehicles (s)	VEH, VEHS
It Is	ITS	Warning	WARN
Junction	JCT	Wednesday	WED
Left	LFT	Weight Limit	WT LIMIT
Left Lane	LFT LN	West	W
Lane Closed	LN CLOSED	Westbound	(route) W
Lower Level	LWR LEVEL	Wet Pavement	WET PVMT
Maintenance	MAINT	Will Not	WONT

Roadway designation # IH-number, US-number, SH-number, FM-number

APPLICATION GUIDELINES

- Only 1 or 2 phases are to be used on a PCMS.
- The 1st phase (or both) should be selected from the "Road/Lane/Ramp Closure List" and the "Other Condition List".
- A 2nd phase can be selected from the "Action to Take/Effect on Travel, Location, General Warning, or Advance Notice Phase Lists".
- A Location Phase is necessary only if a distance or location is not included in the first phase selected.
- If two PCMS are used in sequence, they must be separated by a minimum of 1000 ft. Each PCMS shall be limited to two phases, and should be understandable by themselves.
- For advance notice, when the current date is within seven days of the actual work date, calendar days should be replaced with days of the week. Advance notification should typically be for no more than one week prior to the work.

WORDING ALTERNATIVES

- The words RIGHT, LEFT and ALL can be interchanged as appropriate.
- Roadway designations IH, US, SH, FM and LP can be interchanged as appropriate.
- EAST, WEST, NORTH and SOUTH (or abbreviations E, W, N and S) can be interchanged as appropriate.
- Highway names and numbers replaced as appropriate.
- ROAD, HIGHWAY and FREEWAY can be interchanged as needed.
- AHEAD may be used instead of distances if necessary.
- FT and MI, MILE and MILES interchanged as appropriate.
- AT, BEFORE and PAST interchanged as needed.
- Distances or AHEAD can be eliminated from the message if a location phase is used.

PCMS SIGNS WITHIN THE R.O.W. SHALL BE BEHIND GUARDRAIL OR CONCRETE BARRIER OR SHALL HAVE A MINIMUM OF FOUR (4) PLASTIC DRUMS PLACED PERPENDICULAR TO TRAFFIC ON THE UPSTREAM SIDE OF THE PCMS, WHEN EXPOSED TO ONE DIRECTION OF TRAFFIC. WHEN EXPOSED TO TWO WAY TRAFFIC, THE FOUR DRUMS SHOULD BE PLACED WITH ONE DRUM AT EACH OF THE FOUR CORNERS OF THE UNIT.

FULL MATRIX PCMS SIGNS

- When Full Matrix PCMS signs are used, the character height and legibility/visibility requirements shall be maintained as listed in Note 15 under "PORTABLE CHANGEABLE MESSAGE SIGNS" above.
- When symbol signs, such as the "Flagger Symbol" (CW20-7) are represented graphically on the Full Matrix PCMS sign and, with the approval of the Engineer, it shall maintain the legibility/visibility requirement listed above.
- When symbol signs are represented graphically on the Full Matrix PCMS, they shall only supplement the use of the static sign represented, and shall not substitute for, or replace that sign.
- A full matrix PCMS may be used to simulate a flashing arrow board provided it meets the visibility, flash rate and dimming requirements on BC(7), for the same size arrow.

SHEET 6 OF 12



BARRICADE AND CONSTRUCTION PORTABLE CHANGEABLE MESSAGE SIGN (PCMS)

BC (6) - 21

FILE: bc-21.dgn	DN: TxDOT	CK: TxDOT	DW: TxDOT	CK: TxDOT
© TxDOT November 2002	CONT	SECT	JOB	HIGHWAY
REVISIONS	0910	16	165	MLK JR
9-07 8-14	DIST	COUNTY	SHEET NO.	
7-13 5-21	TYLER	SMITH	13	

DATE: DATE TIME FILE: DOCUMENT NAME

DISCLAIMER: The use of this standard is governed by the "Texas Engineering Practice Act". No warranty of any kind is made by TxDOT for any purpose whatsoever. TxDOT assumes no responsibility for the conversion of this standard to other formats or for incorrect results or damages resulting from its use.

- Barrier Reflectors shall be pre-qualified, and conform to the color and reflectivity requirements of DMS-8600. A list of prequalified Barrier Reflectors can be found at the Material Producer List web address shown on BC(1).
- Color of Barrier Reflectors shall be as specified in the TMUTCD. The cost of the reflectors shall be considered subsidiary to Item 512.

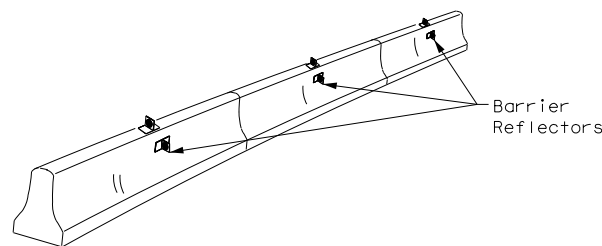

CONCRETE TRAFFIC BARRIER (CTB)

- Where traffic is on one side of the CTB, two (2) Barrier Reflectors shall be mounted in approximately the midsection of each section of CTB. An alternate mounting location is uniformly spaced at one end of each CTB. This will allow for attachment of a barrier grapple without damaging the reflector. The Barrier Reflector mounted on the side of the CTB shall be located directly below the reflector mounted on top of the barrier, as shown in the detail above.
- Where CTB separates two-way traffic, three barrier reflectors shall be mounted on each section of CTB. The reflector unit on top shall have two yellow reflective faces (Bi-Directional) while the reflectors on each side of the barrier shall have one yellow reflective face, as shown in the detail above.
- When CTB separates traffic traveling in the same direction, no barrier reflectors will be required on top of the CTB.
- Barrier Reflector units shall be yellow or white in color to match the edgeline being supplemented.
- Maximum spacing of Barrier Reflectors is forty (40) feet.
- Pavement markers or temporary flexible-reflective roadway marker tabs shall NOT be used as CTB delineation.
- Attachment of Barrier Reflectors to CTB shall be per manufacturer's recommendations.
- Missing or damaged Barrier Reflectors shall be replaced as directed by the Engineer.
- Single slope barriers shall be delineated as shown on the above detail.

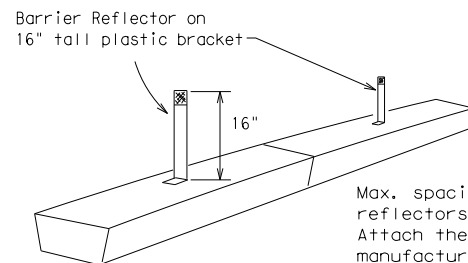

LOW PROFILE CONCRETE BARRIER (LPCB)

LOW PROFILE CONCRETE BARRIER (LPCB) USED IN WORK ZONES

LPCB is approved for use in work zone locations, where the posted speed is 45mph, or less. See Roadway Standard Sheet LPCB.

Max. spacing of barrier reflectors is 20 feet. Attach the delineators as per manufacturer's recommendations.

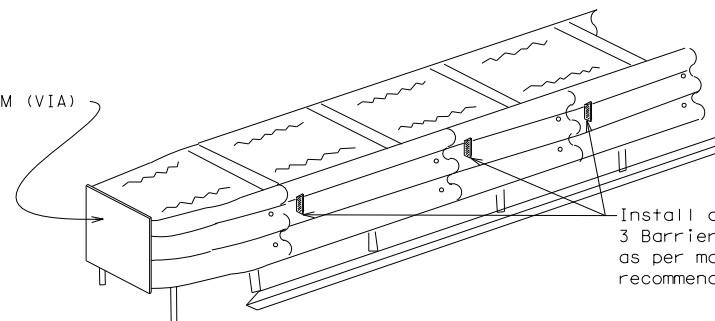

DELINEATION OF END TREATMENTS

END TREATMENTS FOR CTB'S USED IN WORK ZONES

End treatments used on CTB's in work zones shall meet the appropriate crashworthy standards as defined in the Manual for Assessing Safety Hardware (MASH). Refer to the CWZTCD List for approved end treatments and manufacturers.

BARRIER REFLECTORS FOR CONCRETE TRAFFIC BARRIER AND ATTENUATORS

WARNING LIGHTS

- Warning lights shall meet the requirements of the TMUTCD.
- Warning lights shall NOT be installed on barricades.
- Type A-Low Intensity Flashing Warning Lights are commonly used with drums. They are intended to warn of or mark a potentially hazardous area. Their use shall be as indicated on this sheet and/or other sheets of the plans by the designation "FL". The Type A Warning Lights shall not be used with signs manufactured with Type B_{FL} or C_{FL} Sheeting meeting the requirements of Departmental Material Specification DMS-8300.
- Type-C and Type D 360 degree Steady Burn Lights are intended to be used in a series for delineation to supplement other traffic control devices. Their use shall be as indicated on this sheet and/or other sheets of the plans by the designation "SB".
- The Engineer/Inspector or the plans shall specify the location and type of warning lights to be installed on the traffic control devices.
- When required by the Engineer, the Contractor shall furnish a copy of the warning lights certification. The warning light manufacturer will certify the warning lights meet the requirements of the latest ITE Purchase Specifications for Flashing and Steady-Burn Warning Lights.
- When used to delineate curves, Type-C and Type D Steady Burn Lights should only be placed on the outside of the curve, not the inside.
- The location of warning lights and warning reflectors on drums shall be as shown elsewhere in the plans.

WARNING LIGHTS MOUNTED ON PLASTIC DRUMS

- Type A flashing warning lights are intended to warn drivers that they are approaching or are in a potentially hazardous area.
- Type A random flashing warning lights are not intended for delineation and shall not be used in a series.
- A series of sequential flashing warning lights placed on channelizing devices to form a merging taper may be used for delineation. If used, the successive flashing of the sequential warning lights should occur from the beginning of the taper to the end of the merging taper in order to identify the desired vehicle path. The rate of flashing for each light shall be 65 flashes per minute, plus or minus 10 flashes.
- Type C and D steady-burn warning lights are intended to be used in a series to delineate the edge of the travel lane on detours, on lane changes, on lane closures, and on other similar conditions.
- Type A, Type C and Type D warning lights shall be installed at locations as detailed on other sheets in the plans.
- Warning lights shall not be installed on a drum that has a sign, chevron or vertical panel.
- The maximum spacing for warning lights on drums should be identical to the channelizing device spacing.

WARNING REFLECTORS MOUNTED ON PLASTIC DRUMS AS A SUBSTITUTE FOR TYPE C (STEADY BURN) WARNING LIGHTS

- A warning reflector or approved substitute may be mounted on a plastic drum as a substitute for a Type C, steady burn warning light at the discretion of the Contractor unless otherwise noted in the plans.
- The warning reflector shall be yellow in color and shall be manufactured using a sign substrate approved for use with plastic drums listed on the CWZTCD.
- The warning reflector shall have a minimum retroreflective surface area (one-side) of 30 square inches.
- Round reflectors shall be fully reflectorized, including the area where attached to the drum.
- Square substrates must have a minimum of 30 square inches of reflectorized sheeting. They do not have to be reflectorized where it attaches to the drum.
- The side of the warning reflector facing approaching traffic shall have sheeting meeting the color and retroreflectivity requirements for DMS 8300-Type B or Type C.
- When used near two-way traffic, both sides of the warning reflector shall be reflectorized.
- The warning reflector should be mounted on the side of the handle nearest approaching traffic.
- The maximum spacing for warning reflectors should be identical to the channelizing device spacing requirements.

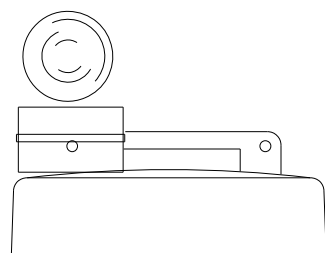

Type C Warning Light or approved substitute mounted on a drum adjacent to the travel way.

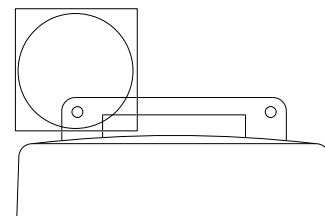

Warning reflector may be round or square. Must have a yellow reflective surface area of at least 30 square inches

DATE: DATE TIME
FILE: DOCUMENT NAME

Arrow Boards may be located behind channelizing devices in place for a shoulder taper or merging taper, otherwise they shall be delineated with four (4) channelizing devices placed perpendicular to traffic on the upstream side of traffic.

- The Flashing Arrow Board should be used for all lane closures on multi-lane roadways, or slow moving maintenance or construction activities on the travel lanes.
- Flashing Arrow Boards should not be used on two-lane, two-way roadways, detours, diversions or work on shoulders unless the "CAUTION" display (see detail below) is used.
- The Engineer/Inspector shall choose all appropriate signs, barricades and/or other traffic control devices that should be used in conjunction with the Flashing Arrow Board.
- The Flashing Arrow Board should be able to display the following symbols:

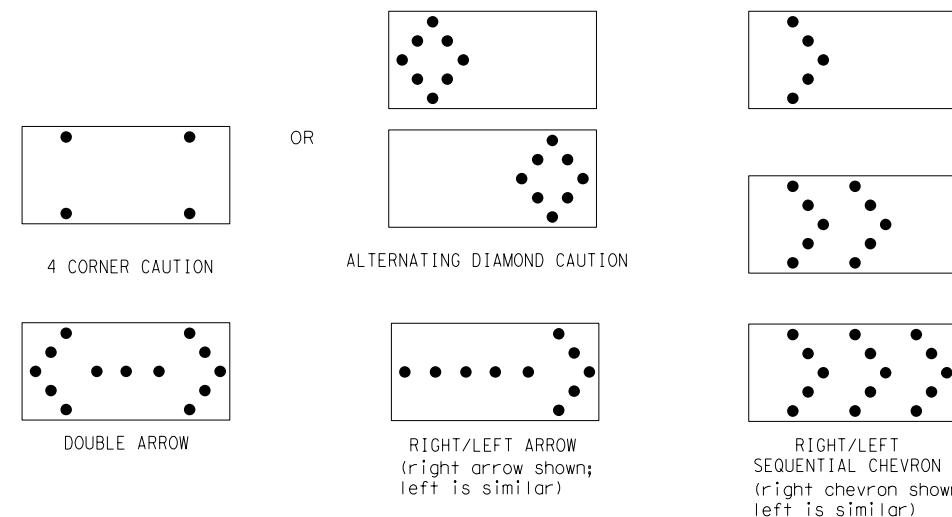

- The "CAUTION" display consists of four corner lamps flashing simultaneously, or the Alternating Diamond Caution mode as shown.
- The straight line caution display is NOT ALLOWED.
- The Flashing Arrow Board shall be capable of minimum 50 percent dimming from rated lamp voltage. The flashing rate of the lamps shall not be less than 25 nor more than 40 flashes per minute.
- Minimum lamp "on time" shall be approximately 50 percent for the flashing arrow and equal intervals of 25 percent for each sequential phase of the flashing chevron.
- The sequential arrow display is NOT ALLOWED.
- The flashing arrow display is the TxDOT standard; however, the sequential chevron display may be used during daylight operations.
- The Flashing Arrow Board shall be mounted on a vehicle, trailer or other suitable support.
- A Flashing Arrow Board SHALL NOT BE USED to laterally shift traffic.
- A full matrix PCMS may be used to simulate a Flashing Arrow Board provided it meets visibility, flash rate and dimming requirements on this sheet for the same size arrow.
- Minimum mounting height of trailer mounted Arrow Boards should be 7 feet from roadway to bottom of panel.

REQUIREMENTS			
TYPE	MINIMUM SIZE	MINIMUM NUMBER OF PANEL LAMPS	MINIMUM VISIBILITY DISTANCE
B	30 x 60	13	3/4 mile
C	48 x 96	15	1 mile

ATTENTION
Flashing Arrow Boards shall be equipped with automatic dimming devices.

WHEN NOT IN USE, REMOVE THE ARROW BOARD FROM THE RIGHT-OF-WAY OR PLACE THE ARROW BOARD BEHIND CONCRETE TRAFFIC BARRIER OR GUARDRAIL.

FLASHING ARROW BOARDS

TRUCK-MOUNTED ATTENUATORS

- Truck-mounted attenuators (TMA) used on TxDOT facilities must meet the requirements outlined in the Manual for Assessing Safety Hardware (MASH).
- Refer to the CWZTCD for the requirements of Level 2 or Level 3 TMAs.
- Refer to the CWZTCD for a list of approved TMAs.
- TMAs are required on freeways unless otherwise noted in the plans.
- A TMA should be used anytime that it can be positioned 30 to 100 feet in advance of the area of crew exposure without adversely affecting the work performance.
- The only reason a TMA should not be required is when a work area is spread down the roadway and the work crew is an extended distance from the TMA.

Traffic Safety Division Standard

BARRICADE AND CONSTRUCTION ARROW PANEL, REFLECTORS, WARNING LIGHTS & ATTENUATOR

BC(7)-21

FILE: bc-21.dgn	DN: TxDOT	CK: TxDOT	DW: TxDOT	CK: TxDOT
©TxDOT November 2002	CONT	SECT	JOB	HIGHWAY
REVISIONS	0910	16	165	MLK JR
9-07 8-14	DIST	COUNTY	SHEET NO.	
7-13 5-21	TYLER	SMITH	14	

DISCLAIMER: The use of this standard is governed by the "Texas Engineering Practice Act". No warranty of any kind is made by TxDOT for any purpose whatsoever. TxDOT assumes no responsibility for the conversion of this standard to other formats or for incorrect results or damages resulting from its use.

DATE: DATE TIME
 FILE: DOCUMENT NAME

GENERAL NOTES

- For long term stationary work zones on freeways, drums shall be used as the primary channelizing device.
- For intermediate term stationary work zones on freeways, drums should be used as the primary channelizing device but may be replaced in tangent sections by vertical panels, or 42" two-piece cones. In tangent sections, one-piece cones may be used with the approval of the Engineer but only if personnel are present on the project at all times to maintain the cones in proper position and location.
- For short term stationary work zones on freeways, drums are the preferred channelizing device but may be replaced in tapers, transitions and tangent sections by vertical panels, two-piece cones or one-piece cones as approved by the Engineer.
- Drums and all related items shall comply with the requirements of the current version of the "Texas Manual on Uniform Traffic Control Devices" (TMUTCD) and the "Compliant Work Zone Traffic Control Devices List" (CWZTCD).
- Drums, bases, and related materials shall exhibit good workmanship and shall be free from objectionable marks or defects that would adversely affect their appearance or serviceability.
- The Contractor shall have a maximum of 24 hours to replace any plastic drums identified for replacement by the Engineer/Inspector. The replacement device must be an approved device.

GENERAL DESIGN REQUIREMENTS

Pre-qualified plastic drums shall meet the following requirements:

- Plastic drums shall be a two-piece design; the "body" of the drum shall be the top portion and the "base" shall be the bottom.
- The body and base shall lock together in such a manner that the body separates from the base when impacted by a vehicle traveling at a speed of 20 MPH or greater but prevents accidental separation due to normal handling and/or air turbulence created by passing vehicles.
- Plastic drums shall be constructed of lightweight flexible, and deformable materials. The Contractor shall NOT use metal drums or single piece plastic drums as channelization devices or sign supports.
- Drums shall present a profile that is a minimum of 18 inches in width at the 36 inch height when viewed from any direction. The height of drum unit (body installed on base) shall be a minimum of 36 inches and a maximum of 42 inches.
- The top of the drum shall have a built-in handle for easy pickup and shall be designed to drain water and not collect debris. The handle shall have a minimum of two widely spaced 9/16 inch diameter holes to allow attachment of a warning light, warning reflector unit or approved compliant sign.
- The exterior of the drum body shall have a minimum of four alternating orange and white retroreflective circumferential stripes not less than 4 inches nor greater than 8 inches in width. Any non-reflectorized space between any two adjacent stripes shall not exceed 2 inches in width.
- Bases shall have a maximum width of 36 inches, a maximum height of 4 inches, and a minimum of two footholds of sufficient size to allow base to be held down while separating the drum body from the base.
- Plastic drums shall be constructed of ultra-violet stabilized, orange, high-density polyethylene (HDPE) or other approved material.
- Drum body shall have a maximum unballasted weight of 11 lbs.
- Drum and base shall be marked with manufacturer's name and model number.

RETROREFLECTIVE SHEETING

- The stripes used on drums shall be constructed of sheeting meeting the color and retroreflectivity requirements of Departmental Materials Specification DMS-8300, "Sign Face Materials." Type A or Type B reflective sheeting shall be supplied unless otherwise specified in the plans.
- The sheeting shall be suitable for use on and shall adhere to the drum surface such that, upon vehicular impact, the sheeting shall remain adhered in-place and exhibit no delaminating, cracking, or loss of retroreflectivity other than that loss due to abrasion of the sheeting surface.

BALLAST

- Unballasted bases shall be large enough to hold up to 50 lbs. of sand. This base, when filled with the ballast material, should weigh between 35 lbs (minimum) and 50 lbs (maximum). The ballast may be sand in one to three sandbags separate from the base, sand in a sand-filled plastic base, or other ballasting devices as approved by the Engineer. Stacking of sandbags will be allowed, however height of sandbags above pavement surface may not exceed 12 inches.
- Bases with built-in ballast shall weigh between 40 lbs. and 50 lbs. Built-in ballast can be constructed of an integral crumb rubber base or a solid rubber base.
- Recycled truck tire sidewalls may be used for ballast on drums approved for this type of ballast on the CWZTCD list.
- The ballast shall not be heavy objects, water, or any material that would become hazardous to motorists, pedestrians, or workers when the drum is struck by a vehicle.
- When used in regions susceptible to freezing, drums shall have drainage holes in the bottoms so that water will not collect and freeze becoming a hazard when struck by a vehicle.
- Ballast shall not be placed on top of drums.
- Adhesives may be used to secure base of drums to pavement.

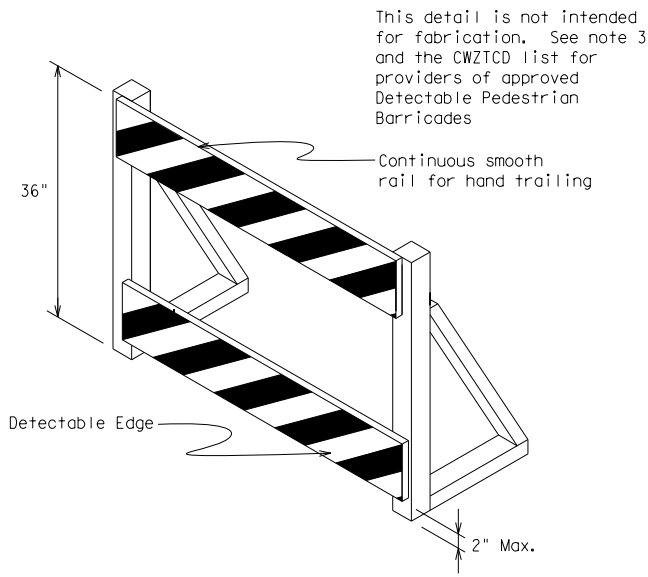
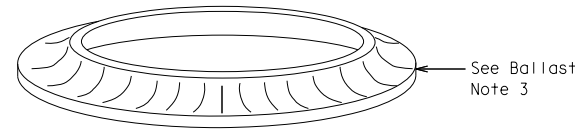
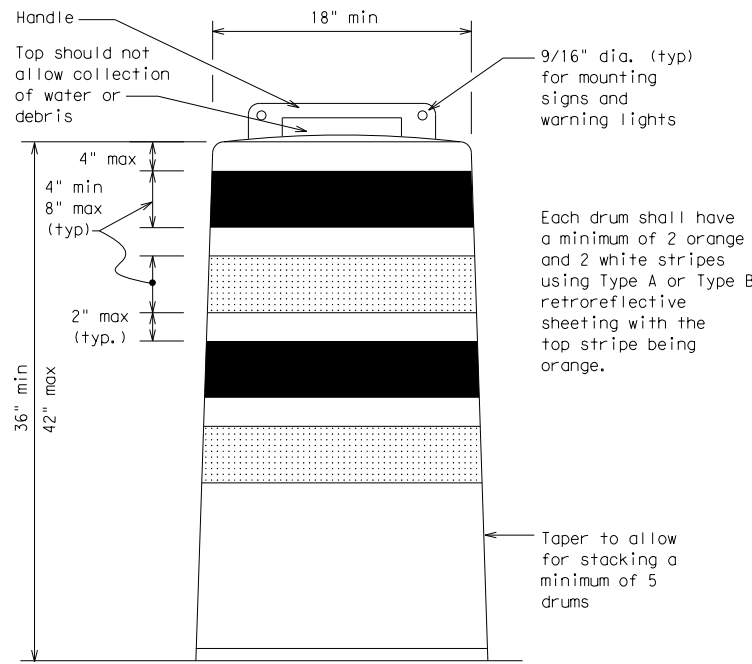

DETECTABLE PEDESTRIAN BARRICADES

- When existing pedestrian facilities are disrupted, closed, or relocated in a TTC zone, the temporary facilities shall be detectable and include accessibility features consistent with the features present in the existing pedestrian facility. Refer to WZ(BTS-2) for Pedestrian Control requirements for Sidewalk Diversions, Sidewalk Detours and Crosswalk Closures.
- Where pedestrians with visual disabilities normally use the closed sidewalk, a Detectable Pedestrian Barricade shall be placed across the full width of the closed sidewalk instead of a Type 3 Barricade.
- Detectable pedestrian barricades similar to the one pictured above, longitudinal channelizing devices, some concrete barriers, and wood or chain link fencing with a continuous detectable edging can satisfactorily delineate a pedestrian path.
- Tape, rope, or plastic chain strung between devices are not detectable, do not comply with the design standards in the "Americans with Disabilities Act Accessibility Guidelines (ADAAG)" and should not be used as a control for pedestrian movements.
- Warning lights shall not be attached to detectable pedestrian barricades.
- Detectable pedestrian barricades should use 8" nominal barricade rails as shown on BC(10) provided that the top rail provides a smooth continuous rail suitable for hand trailing with no splinters, burrs, or sharp edges.

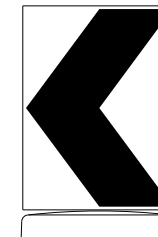

18" x 24" Sign
(Maximum Sign Dimension)
Chevron CW1-8, Opposing Traffic Lane
Divider, Driveway sign D70a, Keep Right
R4 series or other signs as approved
by Engineer

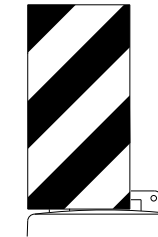

12" x 24"
Vertical Panel
mount with diagonals
sloping down towards
travel way

Plywood, Aluminum or Metal sign
substrates shall NOT be used on
plastic drums

SIGNS, CHEVRONS, AND VERTICAL PANELS MOUNTED ON PLASTIC DRUMS

- Signs used on plastic drums shall be manufactured using substrates listed on the CWZTCD.
- Chevrons and other work zone signs with an orange background shall be manufactured with Type B_{FL} or Type C_{FL} Orange sheeting meeting the color and retroreflectivity requirements of DMS-8300, "Sign Face Material," unless otherwise specified in the plans.
- Vertical Panels shall be manufactured with orange and white sheeting meeting the requirements of DMS-8300 Type A or Type B. Diagonal stripes on Vertical Panels shall slope down toward the intended traveled lane.
- Other sign messages (text or symbolic) may be used as approved by the Engineer. Sign dimensions shall not exceed 18 inches in width or 24 inches in height, except for the R9 series signs discussed in note 8 below.
- Signs shall be installed using a 1/2 inch bolt (nominal) and nut, two washers, and one locking washer for each connection.
- Mounting bolts and nuts shall be fully engaged and adequately torqued. Bolts should not extend more than 1/2 inch beyond nuts.
- Chevrons may be placed on drums on the outside of curves, on merging tapers or on shifting tapers. When used in these locations, they may be placed on every drum or spaced not more than on every third drum. A minimum of three (3) should be used at each location called for in the plans.
- R9-9, R9-10, R9-11 and R9-11a Sidewalk Closed signs which are 24 inches wide may be mounted on plastic drums, with approval of the Engineer.

SHEET 8 OF 12



BARRICADE AND CONSTRUCTION CHANNELIZING DEVICES

BC (8) - 21

FILE:	bc-21.dgn	DN:	TxDOT	CK:	TxDOT	DW:	TxDOT	CK:	TxDOT
© TxDOT	November 2002	CONT	SECT	JOB	HIGHWAY				
REVISIONS		0910	16	165	MLK JR				
4-03	8-14	DIST	COUNTY	SHEET NO.					
9-07	5-21	TYLER	SMITH	15					
7-13									

DISCLAIMER: The use of this standard is governed by the "Texas Engineering Practice Act". No warranty of any kind is made by TxDOT for any purpose whatsoever. TxDOT assumes no responsibility for the conversion of this standard to other formats or for incorrect results or damages resulting from its use.

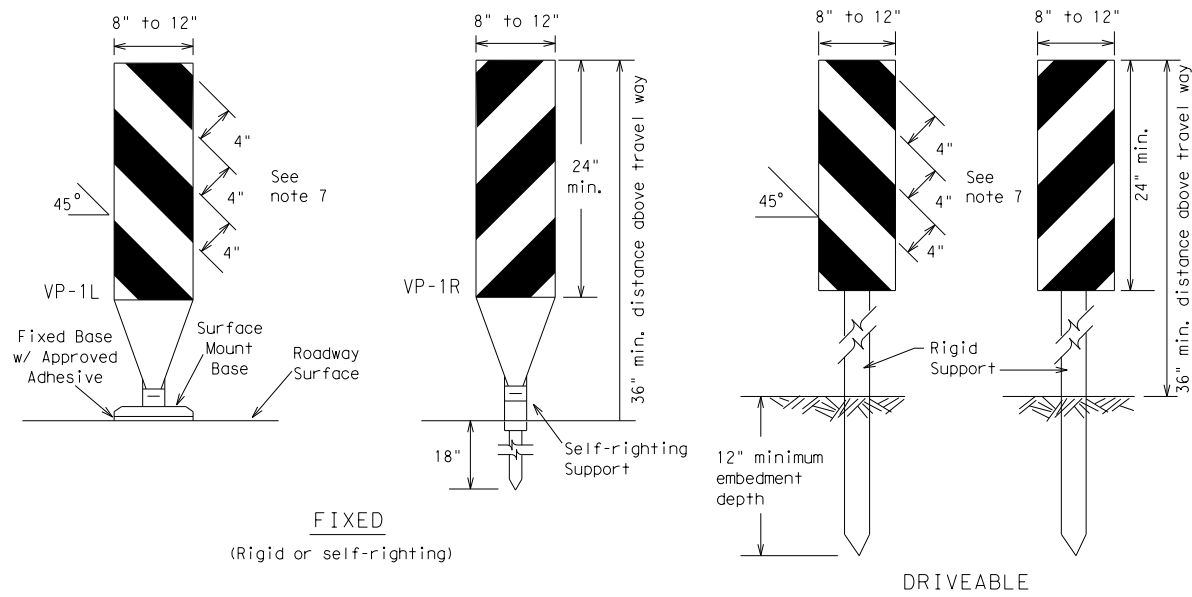

FIXED
(Rigid or self-righting)

DRIVEABLE

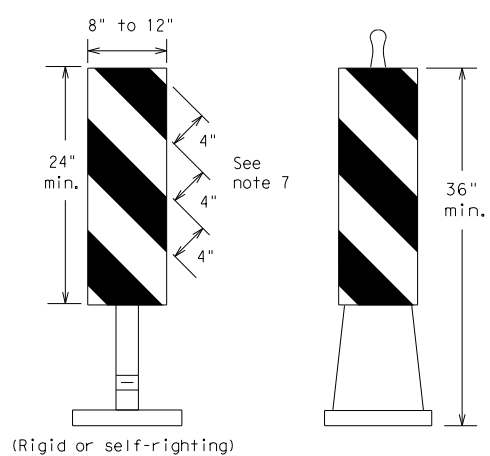

PORTABLE

VERTICAL PANELS (VPs)

- Vertical Panels (VP's) are normally used to channelize traffic or divide opposing lanes of traffic.
- VP's may be used in daytime or nighttime situations. They may be used at the edge of shoulder drop-offs and other areas such as lane transitions where positive daytime and nighttime delineation is required. The Engineer/Inspector shall refer to the Roadway Design Manual for additional requirements on the use VP's for drop-offs.
- VP's should be mounted back to back if used at the edge of cuts adjacent to two-way two lane roadways. Stripes are to be reflective orange and reflective white and should always slope downward toward the travel lane.
- VP's used on expressways and freeways or other high speed roadways, may have more than 270 square inches of retroreflective area facing traffic.
- Self-righting supports are available with portable base. See "Compliant Work Zone Traffic Control Devices List" (CWZTCD).
- Sheeting for the VP's shall be retroreflective Type A or Type B conforming to Departmental Material Specification DMS-8300, unless noted otherwise.
- Where the height of reflective material on the vertical panel is 36 inches or greater, a panel stripe of 6 inches shall be used.

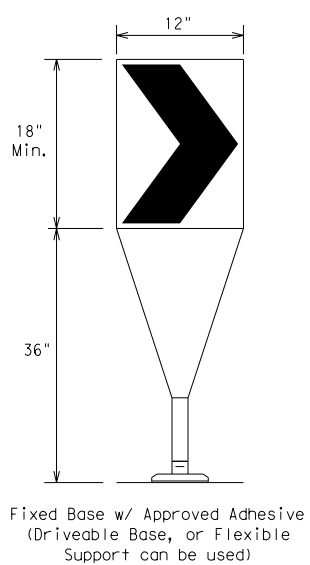

Fixed Base w/ Approved Adhesive
(Driveable Base, or Flexible Support can be used)

- The chevron shall be a vertical rectangle with a minimum size of 12 by 18 inches.
- Chevrons are intended to give notice of a sharp change of alignment with the direction of travel and provide additional emphasis and guidance for vehicle operators with regard to changes in horizontal alignment of the roadway.
- Chevrons, when used, shall be erected on the outside of a sharp curve or turn, or on the far side of an intersection. They shall be in line with and at right angles to approaching traffic. Spacing should be such that the motorist always has three in view, until the change in alignment eliminates its need.
- To be effective, the chevron should be visible for at least 500 feet.
- Chevrons shall be orange with a black nonreflective legend. Sheeting for the chevron shall be retroreflective Type B_{FL} or Type C_{FL} conforming to Departmental Material Specification DMS-8300, unless noted otherwise. The legend shall meet the requirements of DMS-8300.
- For Long Term Stationary use on tapers or transitions on freeways and divided highways, self-righting chevrons may be used to supplement plastic drums but not to replace plastic drums.

CHEVRONS

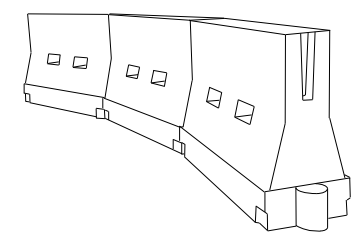

LONGITUDINAL CHANNELIZING DEVICES (LCD)

- LCDs are crashworthy, lightweight, deformable devices that are highly visible, have good target value and can be connected together. They are not designed to contain or redirect a vehicle on impact.
- LCDs may be used instead of a line of cones or drums.
- LCDs shall be placed in accordance to application and installation requirements specific to the device, and used only when shown on the CWZTCD list.
- LCDs should not be used to provide positive protection for obstacles, pedestrians or workers.
- LCDs shall be supplemented with retroreflective delineation as required for temporary barriers on BC(7) when placed roughly parallel to the travel lanes.
- LCDs used as barricades placed perpendicular to traffic should have at least one row of reflective sheeting meeting the requirements for barricade rails as shown on BC(10). Place reflective sheeting near the top of the LCD along the full length of the device.

WATER BALLASTED SYSTEMS USED AS BARRIERS

- Water ballasted systems used as barriers shall not be used solely to channelize road users, but also to protect the work space per the appropriate Manual for Assessing Safety Hardware (MASH) crashworthiness requirements based on roadway speed and barrier application.
- Water ballasted systems used to channelize vehicular traffic shall be supplemented with retroreflective delineation or channelizing devices to improve daytime/nighttime visibility. They may also be supplemented with pavement markings.
- Water ballasted systems used as barriers shall be placed in accordance to application and installation requirements specific to the device, and used only when shown on the CWZTCD list.
- Water ballasted systems used as barriers should not be used for a merging taper except in low speed (less than 45 MPH) urban areas. When used on a taper in a low speed urban area, the taper shall be delineated and the taper length should be designed to optimize road user operations considering the available geometric conditions.
- When water ballasted systems used as barriers have blunt ends exposed to traffic, they should be attenuated as per manufacturer recommendations or flared to a point outside the clear zone.

If used to channelize pedestrians, longitudinal channelizing devices or water ballasted systems must have a continuous detectable bottom for users of long canes and the top of the unit shall not be less than 32 inches in height.

HOLLOW OR WATER BALLASTED SYSTEMS USED AS LONGITUDINAL CHANNELIZING DEVICES OR BARRIERS

GENERAL NOTES

- Work Zone channelizing devices illustrated on this sheet may be installed in close proximity to traffic and are suitable for use on high or low speed roadways. The Engineer/Inspector shall ensure that spacing and placement is uniform and in accordance with the "Texas Manual on Uniform Traffic Control Devices" (TMUTCD).
- Channelizing devices shown on this sheet may have a driveable, fixed or portable base. The requirement for self-righting channelizing devices must be specified in the General Notes or other plan sheets.
- Channelizing devices on self-righting supports should be used in work zone areas where channelizing devices are frequently impacted by errant vehicles or vehicle related wind gusts making alignment of the channelizing devices difficult to maintain. Locations of these devices shall be detailed elsewhere in the plans. These devices shall conform to the TMUTCD and the "Compliant Work Zone Traffic Control Devices List" (CWZTCD).
- The Contractor shall maintain devices in a clean condition and replace damaged, nonreflective, faded, or broken devices and bases as required by the Engineer/Inspector. The Contractor shall be required to maintain proper device spacing and alignment.
- Portable bases shall be fabricated from virgin and/or recycled rubber. The portable bases shall weigh a minimum of 30 lbs.
- Pavement surfaces shall be prepared in a manner that ensures proper bonding between the adhesives, the fixed mount bases and the pavement surface. Adhesives shall be prepared and applied according to the manufacturer's recommendations.
- The installation and removal of channelizing devices shall not cause detrimental effects to the final pavement surfaces, including pavement surface discoloration or surface integrity. Driveable bases shall not be permitted on final pavement surfaces. The Engineer/Inspector shall approve all application and removal procedures of fixed bases.

Posted Speed	Formula	Minimum Desirable Taper Lengths * X			Suggested Maximum Spacing of Channelizing Devices	
		10' Offset	11' Offset	12' Offset	On a Taper	On a Tangent
30	L = WS ² / 60	150'	165'	180'	30'	60'
35		205'	225'	245'	35'	70'
40		265'	295'	320'	40'	80'
45	L = WS	450'	495'	540'	45'	90'
50		500'	550'	600'	50'	100'
55		550'	605'	660'	55'	110'
60		600'	660'	720'	60'	120'
65		650'	715'	780'	65'	130'
70		700'	770'	840'	70'	140'
75		750'	825'	900'	75'	150'
80		800'	880'	960'	80'	160'

*X Taper lengths have been rounded off.
L=Length of Taper (FT.) W=Width of Offset (FT.)
S=Posted Speed (MPH)

SUGGESTED MAXIMUM SPACING OF CHANNELIZING DEVICES AND MINIMUM DESIRABLE TAPER LENGTHS

SHEET 9 OF 12



BARRICADE AND CONSTRUCTION CHANNELIZING DEVICES

BC(9) - 21

FILE: bc-21.dgn	DN: TxDOT	CK: TxDOT	DW: TxDOT	CK: TxDOT
© TxDOT November 2002	CONT	SECT	JOB	HIGHWAY
REVISIONS	0910	16	165	MLK JR
9-07 8-14	DIST	COUNTY	SHEET NO.	
7-13 5-21	TYLER	SMITH	16	

DATE: DATE TIME
FILE: DOCUMENT NAME

OPPOSING TRAFFIC LANE DIVIDERS (OTLD)

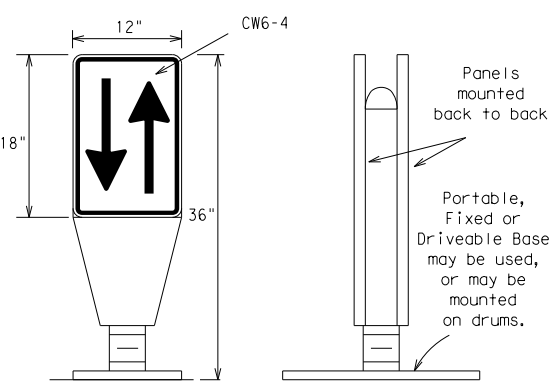

- Opposing Traffic Lane Dividers (OTLD) are delineation devices designed to convert a normal one-way roadway section to two-way operation. OTLD's are used on temporary centerlines. The upward and downward arrows on the sign's face indicate the direction of traffic on either side of the divider. The base is secured to the pavement with an adhesive or rubber weight to minimize movement caused by a vehicle impact or wind gust.
- The OTLD may be used in combination with 42" cones or VPs.
- Spacing between the OTLD shall not exceed 500 feet. 42" cones or VPs placed between the OTLD's should not exceed 100 foot spacing.
- The OTLD shall be orange with a black non-reflective legend. Sheeting for the OTLD shall be retroreflective Type B_{FL} or Type C_{FL} conforming to Departmental Material Specification DMS-8300, unless noted otherwise. The legend shall meet the requirements of DMS-8300.

DISCLAIMER: The use of this standard is governed by the "Texas Engineering Practice Act". No warranty of any kind is made by TxDOT for any purpose whatsoever. TxDOT assumes no responsibility for the conversion of this standard to other formats or for incorrect results or damages resulting from its use.

TYPE 3 BARRICADES

1. Refer to the Compliant Work Zone Traffic Control Devices List (CWZTCD) for details of the Type 3 Barricades and a list of all materials used in the construction of Type 3 Barricades.
2. Type 3 Barricades shall be used at each end of construction projects closed to all traffic.
3. Barricades extending across a roadway should have stripes that slope downward in the direction toward which traffic must turn in detouring. When both right and left turns are provided, the chevron striping may slope downward in both directions from the center of the barricade. Where no turns are provided at a closed road, striping should slope downward in both directions toward the center of roadway.
4. Striping of rails, for the right side of the roadway, should slope downward to the left. For the left side of the roadway, striping should slope downward to the right.
5. Identification markings may be shown only on the back of the barricade rails. The maximum height of letters and/or company logos used for identification shall be 1".
6. Barricades shall not be placed parallel to traffic unless an adequate clear zone is provided.
7. Warning lights shall NOT be installed on barricades.
8. Where barricades require the use of weights to keep from turning over, the use of sandbags with dry, cohesionless sand is recommended. The sandbags will be tied shut to keep the sand from spilling and to maintain a constant weight. Sand bags shall not be stacked in a manner that covers any portion of a barricade rails reflective sheeting. Rock, concrete, iron, steel or other solid objects will NOT be permitted. Sandbags should weigh a minimum of 35 lbs and a maximum of 50 lbs. Sandbags shall be made of a durable material that tears upon vehicular impact. Rubber (such as tire inner tubes) shall not be used for sandbags. Sandbags shall only be placed along or upon the base supports of the device and shall not be suspended above ground level or hung with rope, wire, chains or other fasteners.
9. Sheeting for barricades shall be retroreflective Type A or Type B conforming to Departmental Material Specification DMS-8300 unless otherwise noted.

Barricades shall NOT be used as a sign support.

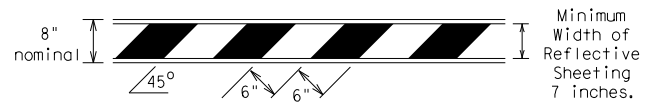

TYPICAL STRIPING DETAIL FOR BARRICADE RAIL

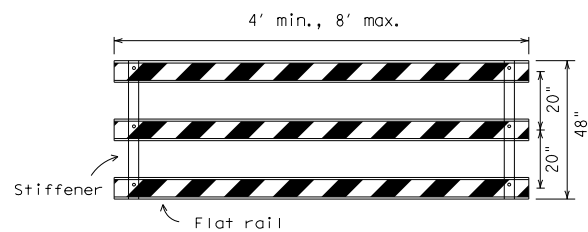

Stiffener may be inside or outside of support, but no more than 2 stiffeners shall be allowed on one barricade.

TYPICAL PANEL DETAIL FOR SKID OR POST TYPE BARRICADES

Each roadway of a divided highway shall be barricaded in the same manner.

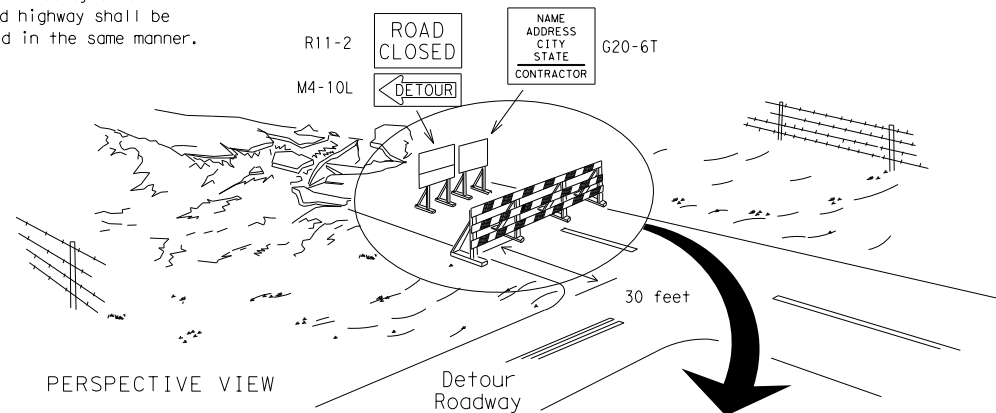

PERSPECTIVE VIEW

The three rails on Type 3 barricades shall be reflectorized orange and reflective white stripes on one side facing one-way traffic and both sides for two-way traffic. Barricade striping should slant downward in the direction of detour.

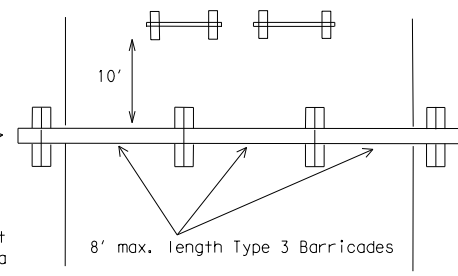

PLAN VIEW

1. Signs should be mounted on independent supports at a 7 foot mounting height in center of roadway. The signs should be a minimum of 10 feet behind Type 3 Barricades.
2. Advance signing shall be as specified elsewhere in the plans.

TYPE 3 BARRICADE (POST AND SKID) TYPICAL APPLICATION

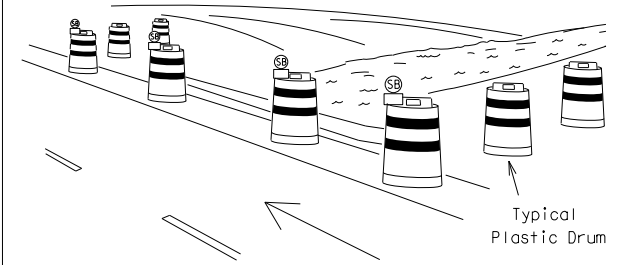

PERSPECTIVE VIEW

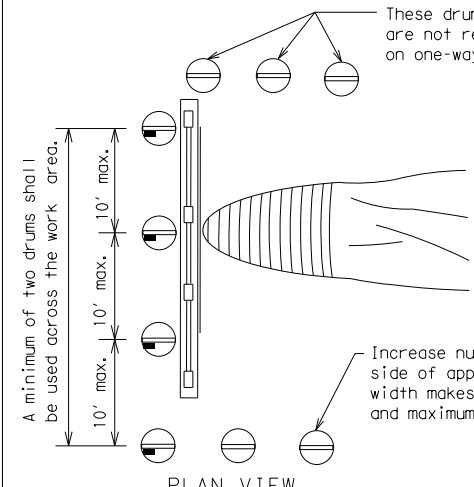

PLAN VIEW

1. Where positive redirection capability is provided, drums may be omitted.
2. Plastic construction fencing may be used with drums for safety as required in the plans.
3. Vertical Panels on flexible support may be substituted for drums when the shoulder width is less than 4 feet.
4. When the shoulder width is greater than 12 feet, steady-burn lights may be omitted if drums are used.
5. Drums must extend the length of the culvert widening.

LEGEND	
	Plastic drum
	Plastic drum with steady burn light or yellow warning reflector
	Steady burn warning light or yellow warning reflector

CULVERT WIDENING OR OTHER ISOLATED WORK WITHIN THE PROJECT LIMITS

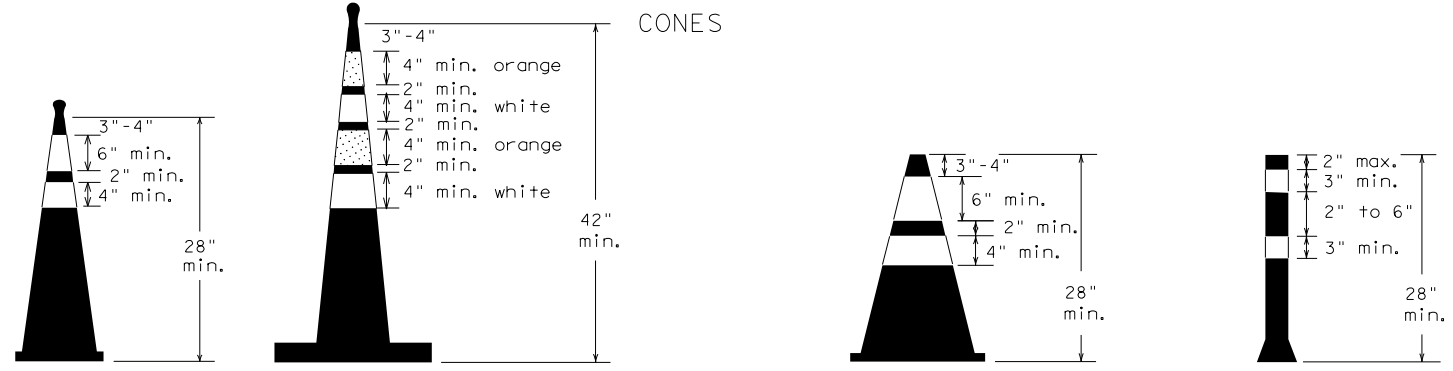

Two-Piece cones

One-Piece cones

Tubular Marker

28" Cones shall have a minimum weight of 9 1/2 lbs.
42" 2-piece cones shall have a minimum weight of 30 lbs. including base.

1. Traffic cones and tubular markers shall be predominantly orange, and meet the height and weight requirements shown above.
2. One-piece cones have the body and base of the cone molded in one consolidated unit. Two-piece cones have a cone shaped body and a separate rubber base, or ballast, that is added to keep the device upright and in place.
3. Two-piece cones may have a handle or loop extending up to 8" above the minimum height shown, in order to aid in retrieving the device.
4. Cones or tubular markers shall have white or white and orange reflective bands as shown above. The reflective bands shall have a smooth, sealed outer surface and meet the requirements of Departmental Material Specification DMS-8300 Type A or Type B.
5. 28" cones and tubular markers are generally suitable for short duration and short-term stationary work as defined on BC(4). These should not be used for intermediate-term or long-term stationary work unless personnel is on-site to maintain them in their proper upright position.
6. 42" two-piece cones, vertical panels or drums are suitable for all work zone durations.
7. Cones or tubular markers used on each project should be of the same size and shape.

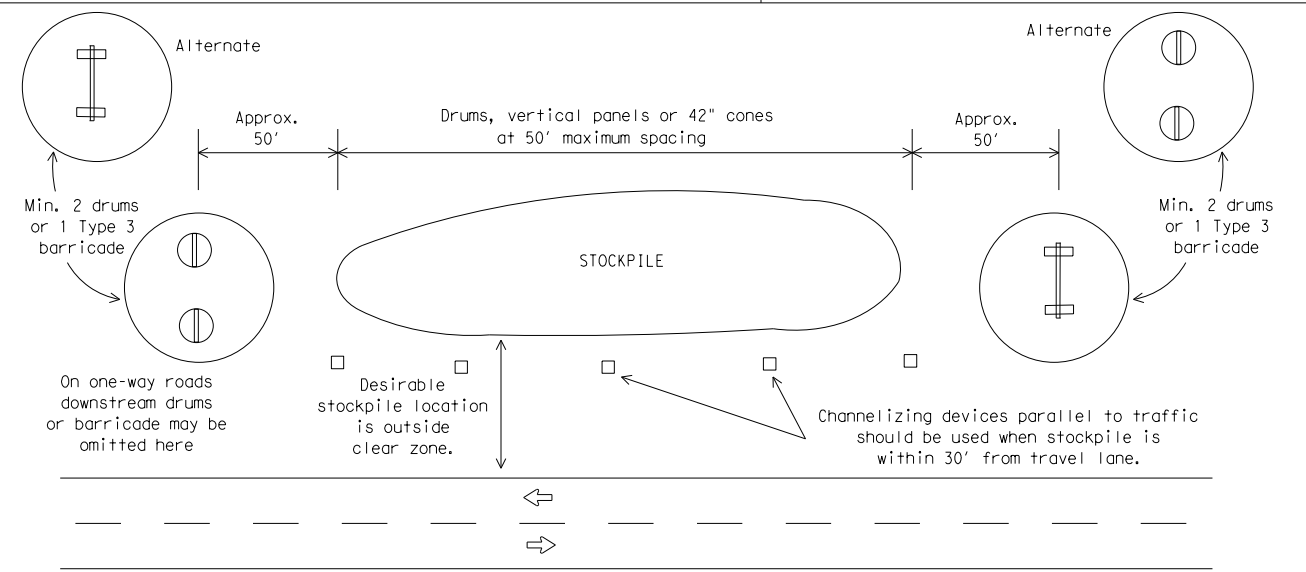

TRAFFIC CONTROL FOR MATERIAL STOCKPILES



BARRICADE AND CONSTRUCTION CHANNELIZING DEVICES

BC (10) - 21

FILE: bc-21.dgn	DN: TxDOT	CK: TxDOT	DW: TxDOT	CK: TxDOT
© TxDOT November 2002	CONT	SECT	JOB	HIGHWAY
REVISIONS	0910	16	165	MLK JR
9-07 8-14	DIST	COUNTY	SHEET NO.	
7-13 5-21	TYLER	SMITH	17	

DATE: DATE TIME
FILE: DOCUMENT NAME

WORK ZONE PAVEMENT MARKINGS

GENERAL

1. The Contractor shall be responsible for maintaining work zone and existing pavement markings, in accordance with the standard specifications and special provisions, on all roadways open to traffic within the CSJ limits unless otherwise stated in the plans.
2. Color, patterns and dimensions shall be in conformance with the "Texas Manual on Uniform Traffic Control Devices" (TMUTCD).
3. Additional supplemental pavement marking details may be found in the plans or specifications.
4. Pavement markings shall be installed in accordance with the TMUTCD and as shown on the plans.
5. When short term markings are required on the plans, short term markings shall conform with the TMUTCD, the plans and details as shown on the Standard Plan Sheet WZ(STPM).
6. When standard pavement markings are not in place and the roadway is opened to traffic, DO NOT PASS signs shall be erected to mark the beginning of the sections where passing is prohibited and PASS WITH CARE signs at the beginning of sections where passing is permitted.
7. All work zone pavement markings shall be installed in accordance with Item 662, "Work Zone Pavement Markings."

RAISED PAVEMENT MARKERS

1. Raised pavement markers are to be placed according to the patterns on BC(12).
2. All raised pavement markers used for work zone markings shall meet the requirements of Item 672, "RAISED PAVEMENT MARKERS" and Departmental Material Specification DMS-4200 or DMS-4300.

PREFABRICATED PAVEMENT MARKINGS

1. Removable prefabricated pavement markings shall meet the requirements of DMS-8241.
2. Non-removable prefabricated pavement markings (foil back) shall meet the requirements of DMS-8240.

MAINTAINING WORK ZONE PAVEMENT MARKINGS

1. The Contractor will be responsible for maintaining work zone pavement markings within the work limits.
2. Work zone pavement markings shall be inspected in accordance with the frequency and reporting requirements of work zone traffic control device inspections as required by Form 599.
3. The markings should provide a visible reference for a minimum distance of 300 feet during normal daylight hours and 160 feet when illuminated by automobile low-beam headlights at night, unless sight distance is restricted by roadway geometrics.
4. Markings failing to meet this criteria within the first 30 days after placement shall be replaced at the expense of the Contractor as per Specification Item 662.

REMOVAL OF PAVEMENT MARKINGS

1. Pavement markings that are no longer applicable, could create confusion or direct a motorist toward or into the closed portion of the roadway shall be removed or obliterated before the roadway is opened to traffic.
2. The above shall not apply to detours in place for less than three days, where flaggers and/or sufficient channelizing devices are used in lieu of markings to outline the detour route.
3. Pavement markings shall be removed to the fullest extent possible, so as not to leave a discernable marking. This shall be by any method approved by TxDOT Specification Item 677 for "Eliminating Existing Pavement Markings and Markers".
4. The removal of pavement markings may require resurfacing or seal coating portions of the roadway as described in Item 677.
5. Subject to the approval of the Engineer, any method that proves to be successful on a particular type pavement may be used.
6. Blast cleaning may be used but will not be required unless specifically shown in the plans.
7. Over-painting of the markings SHALL NOT BE permitted.
8. Removal of raised pavement markers shall be as directed by the Engineer.
9. Removal of existing pavement markings and markers will be paid for directly in accordance with Item 677, "ELIMINATING EXISTING PAVEMENT MARKINGS AND MARKERS," unless otherwise stated in the plans.
10. Black-out marking tape may be used to cover conflicting existing markings for periods less than two weeks when approved by the Engineer.

Temporary Flexible-Reflective Roadway Marker Tabs

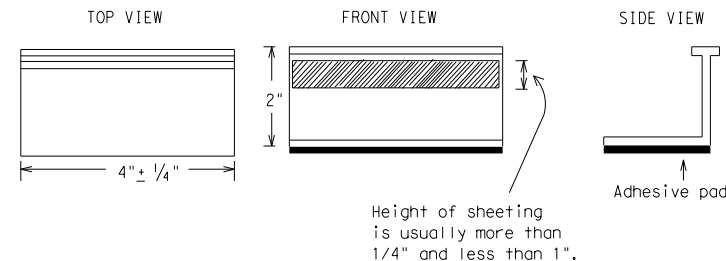

STAPLES OR NAILS SHALL NOT BE USED TO SECURE TEMPORARY FLEXIBLE-REFLECTIVE ROADWAY MARKER TABS TO THE PAVEMENT SURFACE

1. Temporary flexible-reflective roadway marker tabs used as guidemarks shall meet the requirements of DMS-8242.
2. Tabs detailed on this sheet are to be inspected and accepted by the Engineer or designated representative. Sampling and testing is not normally required, however at the option of the Engineer, either "A" or "B" below may be imposed to assure quality before placement on the roadway.
 - A. Select five (5) or more tabs at random from each lot or shipment and submit to the Construction Division, Materials and Pavement Section to determine specification compliance.
 - B. Select five (5) tabs and perform the following test. Affix five (5) tabs at 24 inch intervals on an asphaltic pavement in a straight line. Using a medium size passenger vehicle or pickup, run over the markers with the front and rear tires at a speed of 35 to 40 miles per hour, four (4) times in each direction. No more than one (1) out of the five (5) reflective surfaces shall be lost or displaced as a result of this test.
3. Small design variances may be noted between tab manufacturers.
4. See Standard Sheet WZ(STPM) for tab placement on new pavements. See Standard Sheet TCP(7-1) for tab placement on seal coat work.

RAISED PAVEMENT MARKERS USED AS GUIDEMARKS

1. Raised pavement markers used as guidemarks shall be from the approved product list, and meet the requirements of DMS-4200.
2. All temporary construction raised pavement markers provided on a project shall be of the same manufacturer.
3. Adhesive for guidemarks shall be bituminous material hot applied or butyl rubber pad for all surfaces, or thermoplastic for concrete surfaces.

Guidemarks shall be designated as:
 YELLOW - (two amber reflective surfaces with yellow body).
 WHITE - (one silver reflective surface with white body).

DEPARTMENTAL MATERIAL SPECIFICATIONS	
PAVEMENT MARKERS (REFLECTORIZED)	DMS-4200
TRAFFIC BUTTONS	DMS-4300
EPOXY AND ADHESIVES	DMS-6100
BITUMINOUS ADHESIVE FOR PAVEMENT MARKERS	DMS-6130
PERMANENT PREFABRICATED PAVEMENT MARKINGS	DMS-8240
TEMPORARY REMOVABLE, PREFABRICATED PAVEMENT MARKINGS	DMS-8241
TEMPORARY FLEXIBLE, REFLECTIVE ROADWAY MARKER TABS	DMS-8242

A list of prequalified reflective raised pavement markers, non-reflective traffic buttons, roadway marker tabs and other pavement markings can be found at the Material Producer List web address shown on BC(1).

DISCLAIMER: The use of this standard is governed by the "Texas Engineering Practice Act". No warranty of any kind is made by TxDOT for any purpose whatsoever. TxDOT assumes no responsibility for the conversion of this standard to other formats or for incorrect results or damages resulting from its use.

DATE: DATE TIME
FILE: DOCUMENT NAME

SHEET 11 OF 12



BARRICADE AND CONSTRUCTION PAVEMENT MARKINGS

BC(11)-21

FILE: bc-21.dgn	DN: TxDOT	CK: TxDOT	DW: TxDOT	CK: TxDOT
©TxDOT February 1998	CONT	SECT	JOB	HIGHWAY
REVISIONS	0910	16	165	MLK JR
2-98 9-07 5-21	DIST	COUNTY	SHEET NO.	
1-02 7-13	TYLER	SMITH	18	
11-02 8-14				

PAVEMENT MARKING PATTERNS

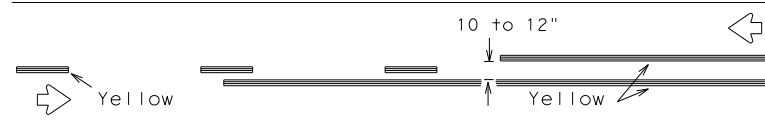

REFLECTORIZED PAVEMENT MARKINGS - PATTERN A

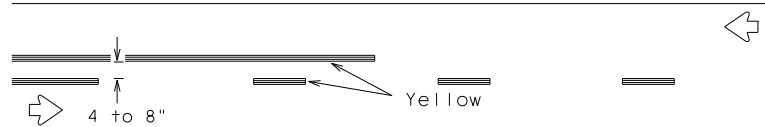

REFLECTORIZED PAVEMENT MARKINGS - PATTERN B

Pattern A is the TXDOT Standard, however Pattern B may be used if approved by the Engineer. Prefabricated markings may be substituted for reflectORIZED pavement markings.

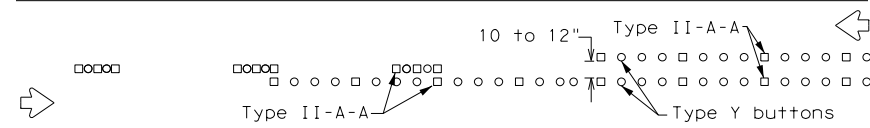

RAISED PAVEMENT MARKERS - PATTERN A

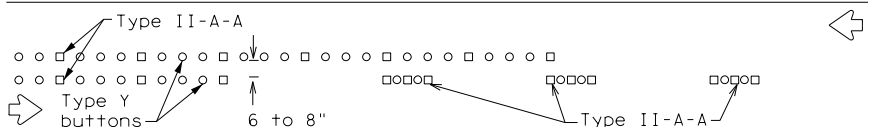

RAISED PAVEMENT MARKERS - PATTERN B

CENTER LINE & NO-PASSING ZONE BARRIER LINES FOR TWO-LANE, TWO-WAY HIGHWAYS

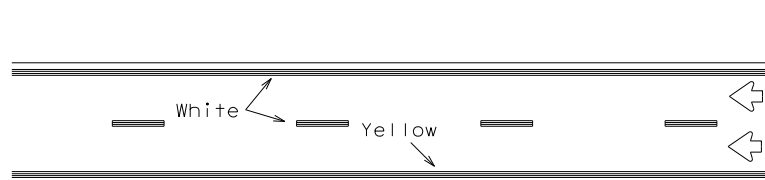

REFLECTORIZED PAVEMENT MARKINGS

Prefabricated markings may be substituted for reflectORIZED pavement markings.

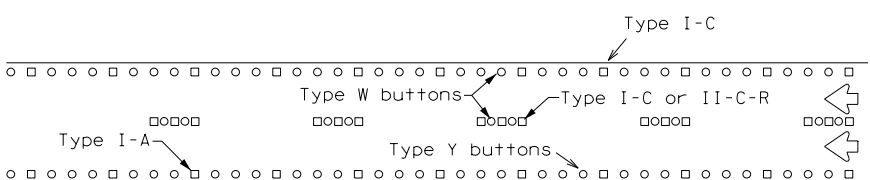

RAISED PAVEMENT MARKERS

EDGE & LANE LINES FOR DIVIDED HIGHWAY

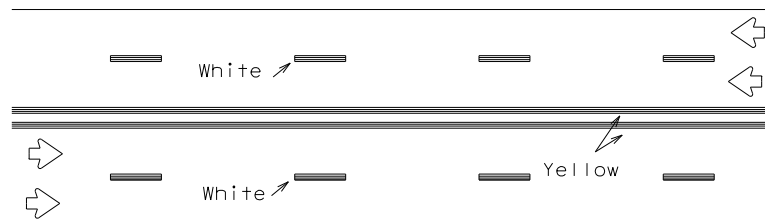

REFLECTORIZED PAVEMENT MARKINGS

Prefabricated markings may be substituted for reflectORIZED pavement markings.

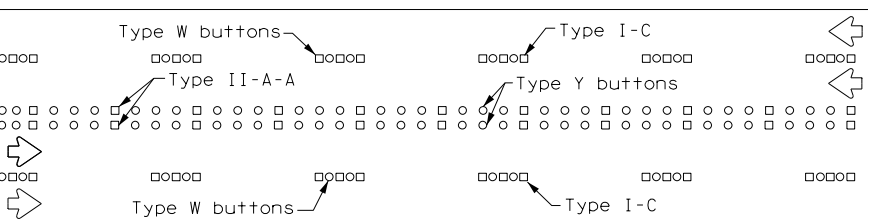

RAISED PAVEMENT MARKERS

LANE & CENTER LINES FOR MULTILANE UNDIVIDED HIGHWAYS

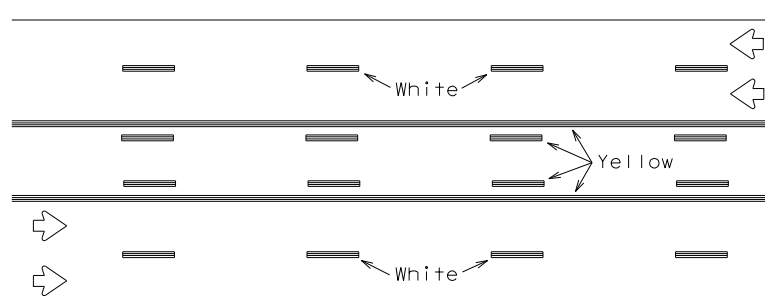

REFLECTORIZED PAVEMENT MARKINGS

Prefabricated markings may be substituted for reflectORIZED pavement markings.

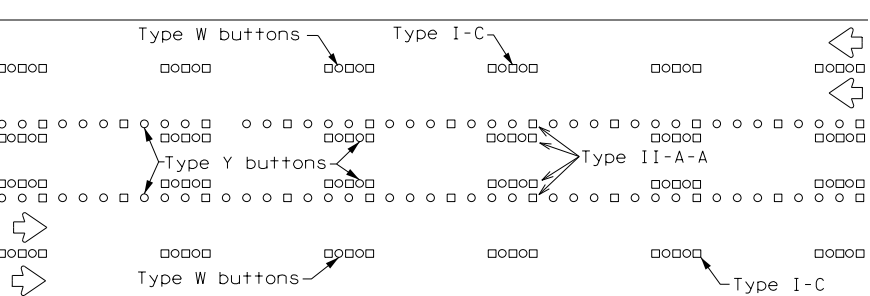

RAISED PAVEMENT MARKERS

TWO-WAY LEFT TURN LANE

STANDARD WORK ZONE PAVEMENT MARKINGS DETAILS

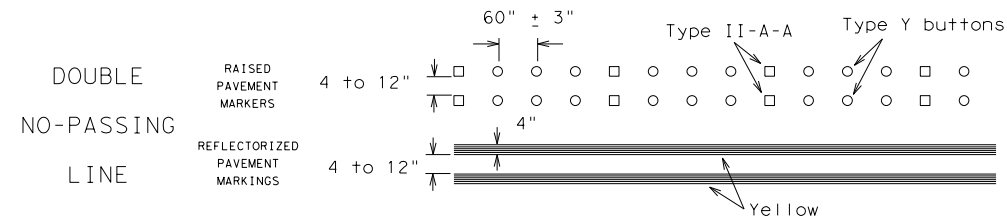

SOLID LINES

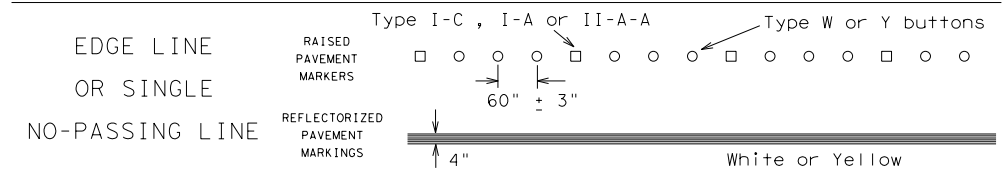

WIDE LINE



CENTER LINE OR LANE LINE

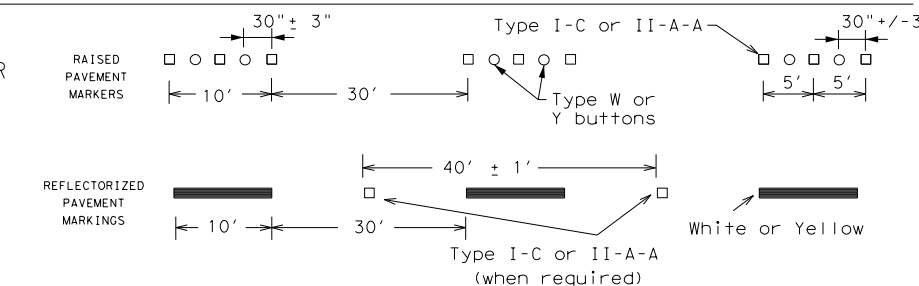

BROKEN LINES

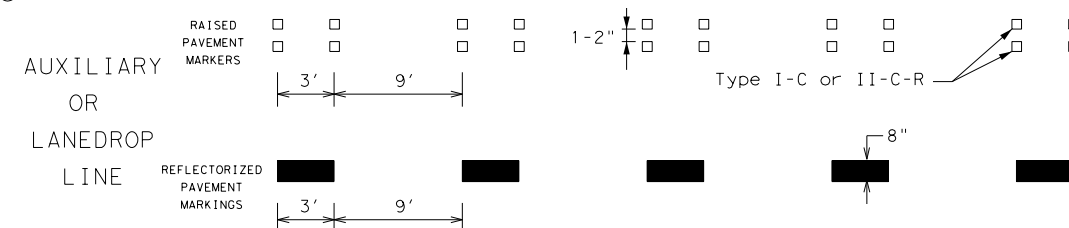

REMOVABLE MARKINGS WITH RAISED PAVEMENT MARKERS

If raised pavement markers are used to supplement REMOVABLE markings, the markers shall be applied to the top of the tape at the approximate mid length of tape used for broken lines or at 20 foot spacing for solid lines. This allows an easier removal of raised pavement markers and tape.

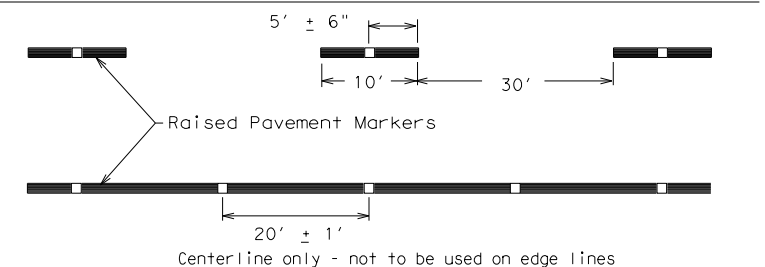

SHEET 12 OF 12



BARRICADE AND CONSTRUCTION PAVEMENT MARKING PATTERNS

BC(12)-21

FILE: bc-21.dgn	DN: TxDOT	CK: TxDOT	DW: TxDOT	CK: TxDOT
©TxDOT February 1998	CONT	SECT	JOB	HIGHWAY
REVISIONS	0910	16	165	MLK JR
1-97 9-07 5-21	DIST	COUNTY	SHEET NO.	
2-98 7-13	TYLER	SMITH	19	
11-02 8-14				

DISCLAIMER: The use of this standard is governed by the "Texas Engineering Practice Act". No warranty of any kind is made by TxDOT for any purpose whatsoever. TxDOT assumes no responsibility for the conversion of this standard to other formats or for incorrect results or damages resulting from its use.

DATE: DATE TIME
FILE: DOCUMENT NAME

Raised pavement markers used as standard pavement markings shall be from the approved products list and meet the requirements of Item 672 "RAISED PAVEMENT MARKERS."

DISCLAIMER: The use of this standard is governed by the "Texas Engineering Practice Act". No warranty of any kind is made by TxDOT for any purpose whatsoever. TxDOT assumes no responsibility for the conversion of this standard to other formats or for incorrect results or damages resulting from its use.

DATE: DATE TIME
FILE: DOCUMENT NAME

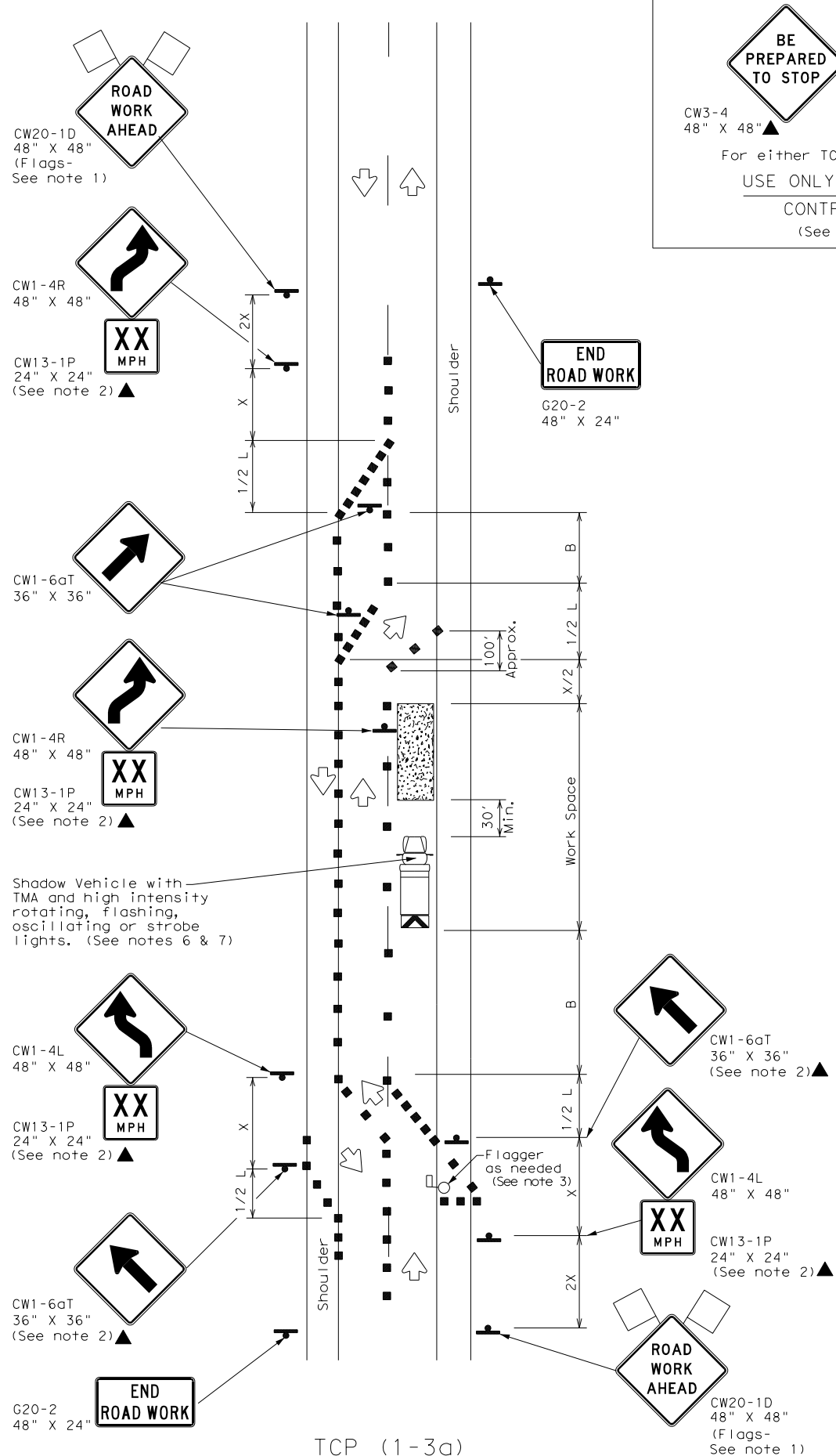

TCP (1-3a)
2-LANE ROADWAY WITH PAVED SHOULDERS
ONE LANE CLOSED
ADEQUATE FIELD OF VIEW

BE PREPARED TO STOP
CW3-4 48" X 48"▲
CW20-7 48" X 48"▲
For either TCP(1-3a) or TCP(1-3b)
USE ONLY WHEN FLAGGERS
CONTROL TRAFFIC
(See Notes 2 & 3)

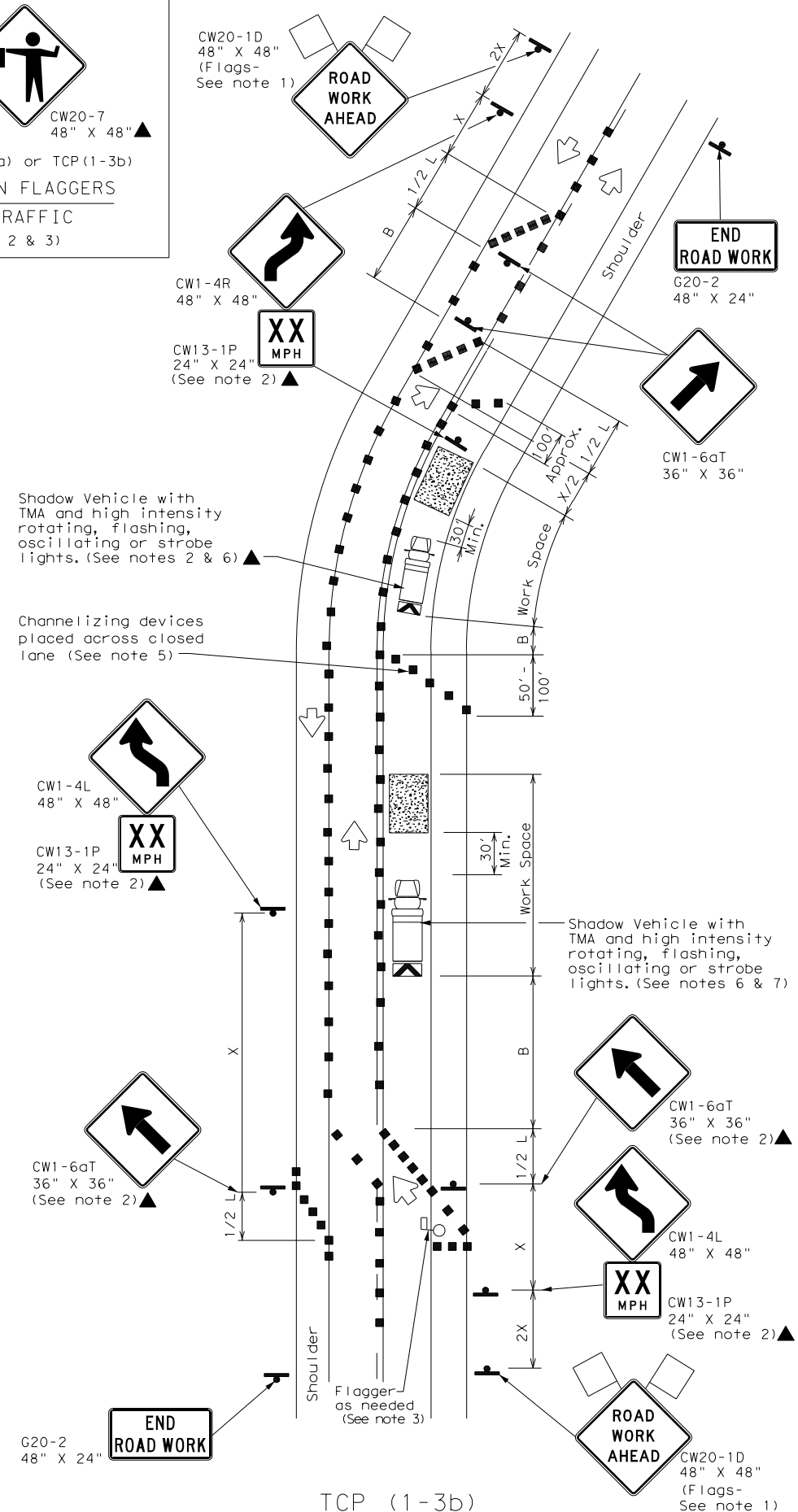

TCP (1-3b)
2-LANE ROADWAY WITH PAVED SHOULDERS
ONE LANE CLOSED
INADEQUATE FIELD OF VIEW

LEGEND			
	Type 3 Barricade		Channelizing Devices
	Heavy Work Vehicle		Truck Mounted Attenuator (TMA)
	Trailer Mounted Flashing Arrow Board		Portable Changeable Message Sign (PCMS)
	Sign		Traffic Flow
	Flag		Flagger

Posted Speed *	Formula	Minimum Desirable Taper Lengths **			Suggested Maximum Spacing of Channelizing Devices		Minimum Sign Spacing "x" Distance	Suggested Longitudinal Buffer Space "B"
		10' Offset	11' Offset	12' Offset	On a Taper	On a Tangent		
30	L = WS/60	150'	165'	180'	30'	60'	120'	90'
35		205'	225'	245'	35'	70'	160'	120'
40		265'	295'	320'	40'	80'	240'	155'
45	L = WS	450'	495'	540'	45'	90'	320'	195'
50		500'	550'	600'	50'	100'	400'	240'
55		550'	605'	660'	55'	110'	500'	295'
60		600'	660'	720'	60'	120'	600'	350'
65		650'	715'	780'	65'	130'	700'	410'
70		700'	770'	840'	70'	140'	800'	475'
75		750'	825'	900'	75'	150'	900'	540'

* Conventional Roads Only
** Taper lengths have been rounded off.
L=Length of Taper (FT) W=Width of Offset (FT) S=Posted Speed (MPH)

TYPICAL USAGE				
MOBILE	SHORT DURATION	SHORT TERM STATIONARY	INTERMEDIATE TERM STATIONARY	LONG TERM STATIONARY
	✓	✓		

- GENERAL NOTES
- Flags attached to signs where shown are REQUIRED.
 - All traffic control devices illustrated are REQUIRED, except those denoted with the triangle symbol may be omitted when stated elsewhere in the plans, or for routine maintenance work, when approved by the Engineer.
 - Flagger control should NOT be used unless roadway conditions or heavy traffic volume require additional emphasis to safely control traffic. Additional flaggers may be positioned in advance of traffic queues to alert traffic to reduce speed.
 - DO NOT PASS, PASS WITH CARE and construction regulatory speed zone signs may be installed downstream of the ROAD WORK AHEAD signs.
 - When the work zone is made up of several work spaces, channelizing devices should be placed laterally across the closed lane to re-emphasize closure. Laterally placed channelizing devices should be repeated every 500 to 1000 feet in urban areas and every 1/4 to 1/2 mile in rural areas.
 - A Shadow Vehicle with a TMA should be used anytime it can be positioned 30 to 100 feet in advance of the area of crew exposure without adversely affecting the performance or quality of the work. If workers are no longer present but road or work conditions require the traffic control to remain in place, Type 3 Barricades or other channelizing devices may be substituted for the Shadow Vehicle and TMA.
 - Additional Shadow Vehicles with TMAs may be positioned off the paved surface, next to those shown in order to protect wider work spaces.
 - Where traffic is directed over a yellow centerline, channelizing devices which separate two-way traffic should be spaced on tapers at 20', or 15' if posted speed are 35 mph or slower, and for tangent sections, at 1/2S where S is the speed in mph. This tighter device spacing is intended for the area of conflicting markings not the entire work zone.

Texas Department of Transportation
Traffic Operations Division Standard

TRAFFIC CONTROL PLAN
TRAFFIC SHIFTS ON
TWO LANE ROADS
TCP(1-3)-18

FILE: tcp1-3-18.dgn	DN:	CK:	DW:	CK:
© TxDOT December 1985	CON:	SECT:	JOB:	HIGHWAY:
REVISIONS	0910	16	165	MLK JR
2-94 4-98	DIST:	COUNTY:	SHEET NO.:	
8-95 2-12	TYLER	SMITH	20	
1-97 2-18				

DISCLAIMER: The use of this standard is governed by the "Texas Engineering Practice Act". No warranty of any kind is made by TxDOT for any purpose whatsoever. TxDOT assumes no responsibility for the conversion of this standard to other formats or for incorrect results or damages resulting from its use.

DATE: DATE TIME
FILE: DOCUMENT NAME

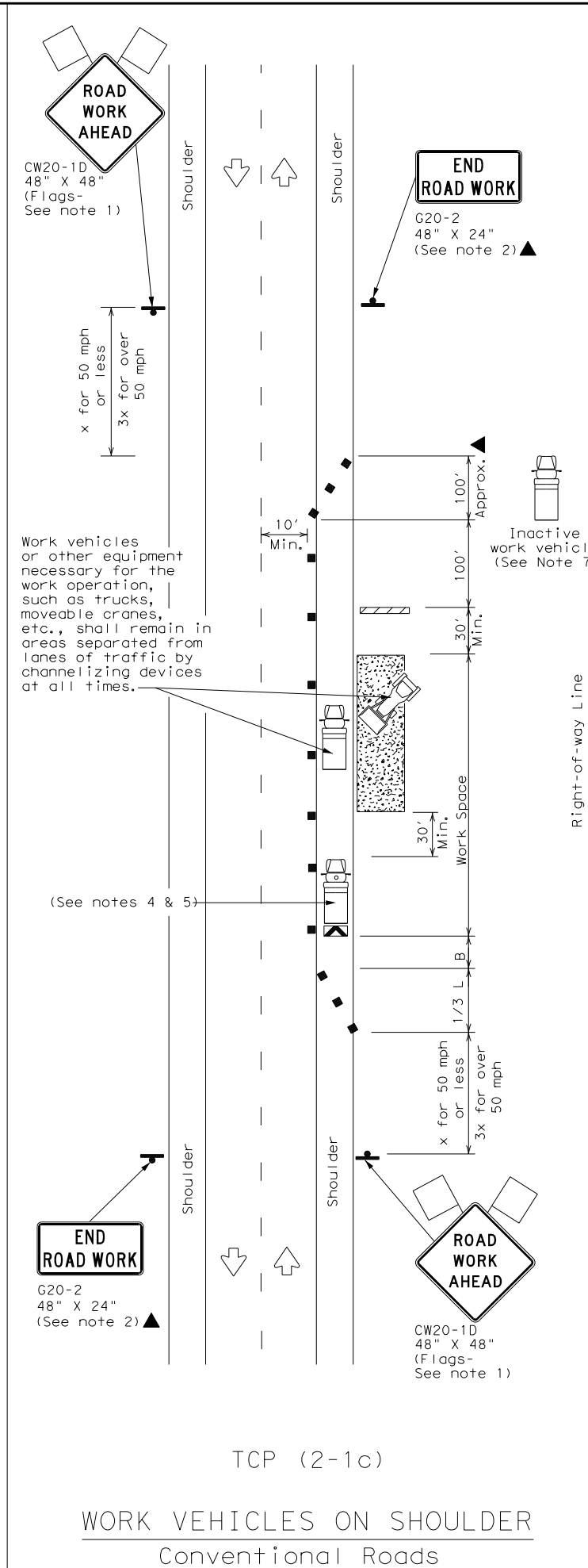
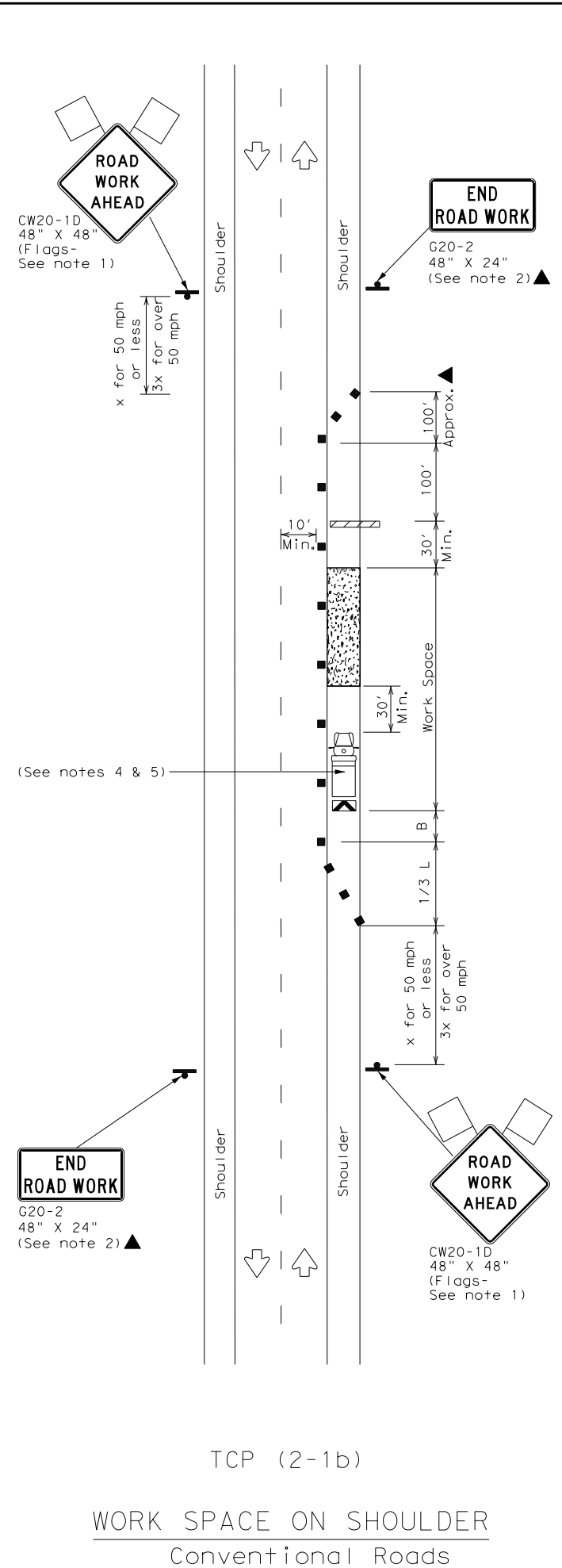
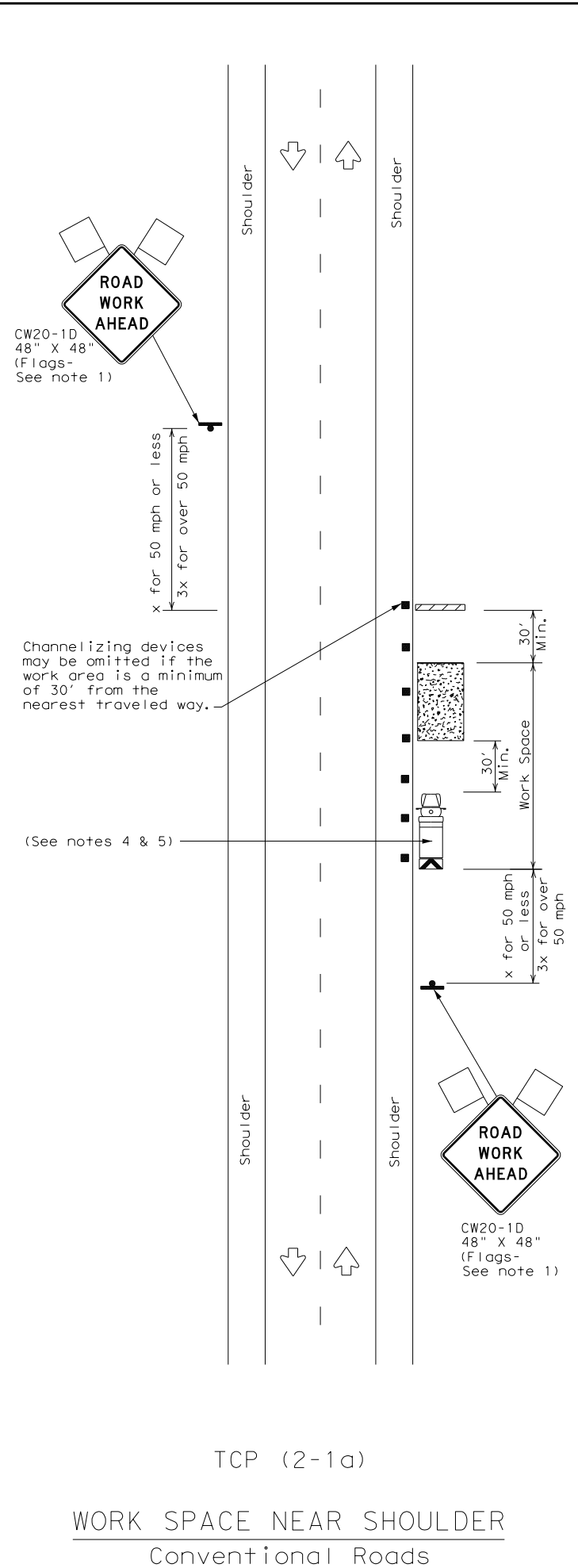

LEGEND			
	Type 3 Barricade		Channelizing Devices
	Heavy Work Vehicle		Truck Mounted Attenuator (TMA)
	Trailer Mounted Flashing Arrow Board		Portable Changeable Message Sign (PCMS)
	Sign		Traffic Flow
	Flag		Flagger

Posted Speed *	Formula	Minimum Desirable Taper Lengths **			Suggested Maximum Spacing of Channelizing Devices		Minimum Sign Spacing "X" Distance	Suggested Longitudinal Buffer Space "B"
		10' Offset	11' Offset	12' Offset	On a Taper	On a Tangent		
30	$L = \frac{WS^2}{60}$	150'	165'	180'	30'	60'	120'	90'
35		205'	225'	245'	35'	70'	160'	120'
40		265'	295'	320'	40'	80'	240'	155'
45	L = WS	450'	495'	540'	45'	90'	320'	195'
50		500'	550'	600'	50'	100'	400'	240'
55		550'	605'	660'	55'	110'	500'	295'
60		600'	660'	720'	60'	120'	600'	350'
65		650'	715'	780'	65'	130'	700'	410'
70		700'	770'	840'	70'	140'	800'	475'
75		750'	825'	900'	75'	150'	900'	540'

* Conventional Roads Only
** Taper lengths have been rounded off.
L=Length of Taper (FT) W=Width of Offset (FT) S=Posted Speed (MPH)

TYPICAL USAGE				
MOBILE	SHORT DURATION	SHORT TERM STATIONARY	INTERMEDIATE TERM STATIONARY	LONG TERM STATIONARY
	✓	✓	✓	✓

- GENERAL NOTES
- Flags attached to signs where shown, are REQUIRED.
 - All traffic control devices illustrated are REQUIRED, except those denoted with the triangle symbol may be omitted when stated in the plans, or for routine maintenance work, when approved by the Engineer.
 - Stockpiled material should be placed a minimum of 30 feet from nearest traveled way.
 - Shadow Vehicle with TMA and high intensity rotating, flashing, oscillating or strobe lights. A Shadow Vehicle with a TMA should be used anytime it can be positioned 30 to 100 feet in advance of the area of crew exposure without adversely affecting the performance or quality of the work. If workers are no longer present but road or work conditions require the traffic control to remain in place, Type 3 Barricades or other channelizing devices may be substituted for the Shadow Vehicle and TMA.
 - Additional Shadow Vehicles with TMAs may be positioned off the paved surface, next to those shown in order to protect a wider work space.
 - See TCP(5-1) for shoulder work on divided highways, expressways and freeways.
 - Inactive work vehicles or other equipment should be parked near the right-of-way line and not parked on the paved shoulder.
 - CW21-5 "SHOULDER WORK" signs may be used in place of CW20-1D "ROAD WORK AHEAD" signs for shoulder work on conventional roadways.

Texas Department of Transportation
Traffic Operations Division Standard

TRAFFIC CONTROL PLAN
CONVENTIONAL ROAD
SHOULDER WORK

TCP (2-1) - 18

FILE: tcp2-1-18.dgn	DN:	CK:	DW:	CK:
© TxDOT December 1985	CON:	SECT:	JOB:	HIGHWAY:
REVISIONS	091016	165	MLK JR	
2-94 4-98	DIST:	COUNTY:	SHEET NO.:	
8-95 2-12	TYLER	SMITH	21	
1-97 2-18				

DISCLAIMER: The use of this standard is governed by the "Texas Engineering Practice Act". No warranty of any kind is made by TxDOT for any purpose whatsoever. TxDOT assumes no responsibility for the conversion of this standard to other formats or for incorrect results or damages resulting from its use.

DATE: DATE TIME
FILE: DOCUMENT NAME

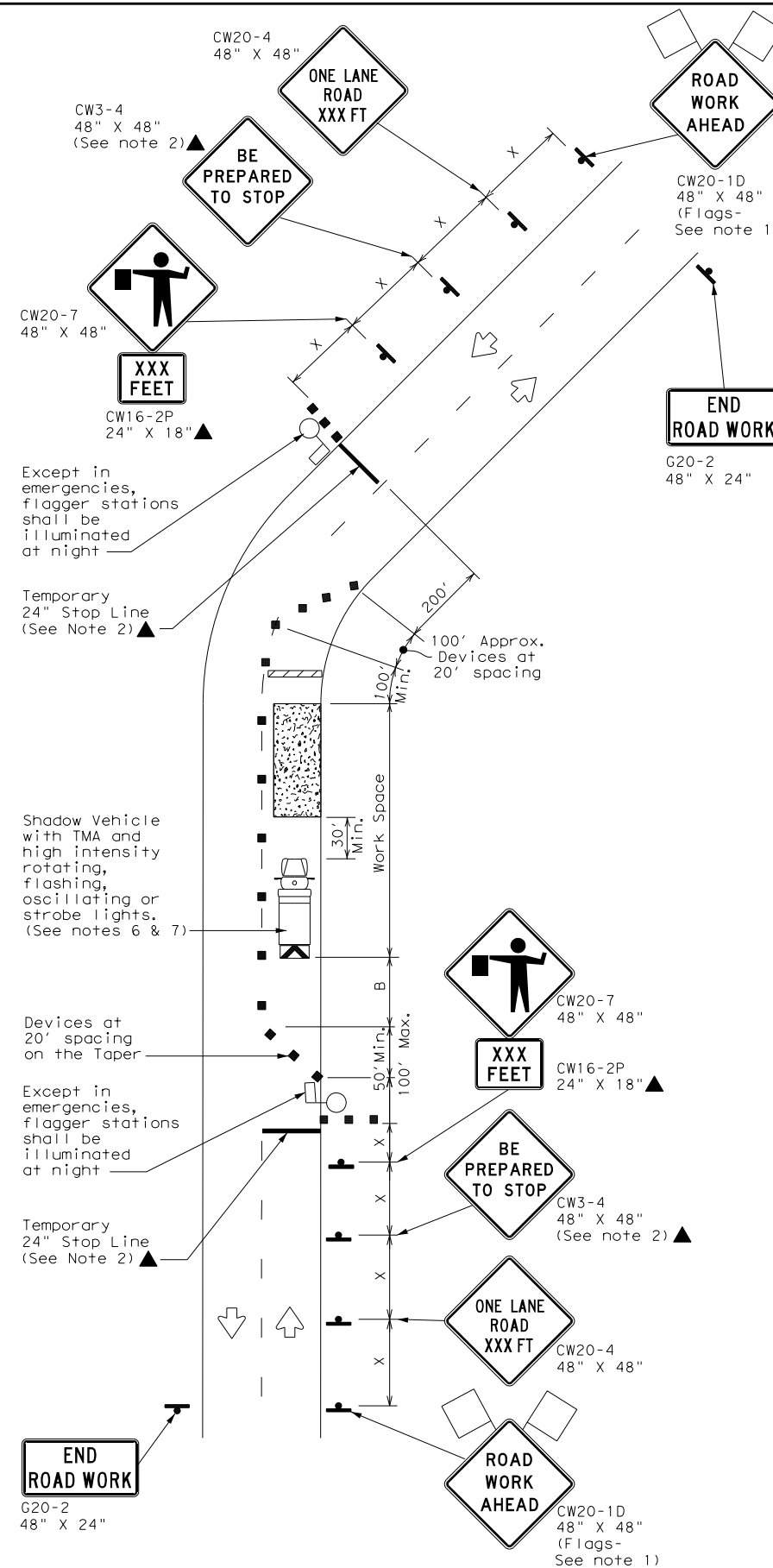
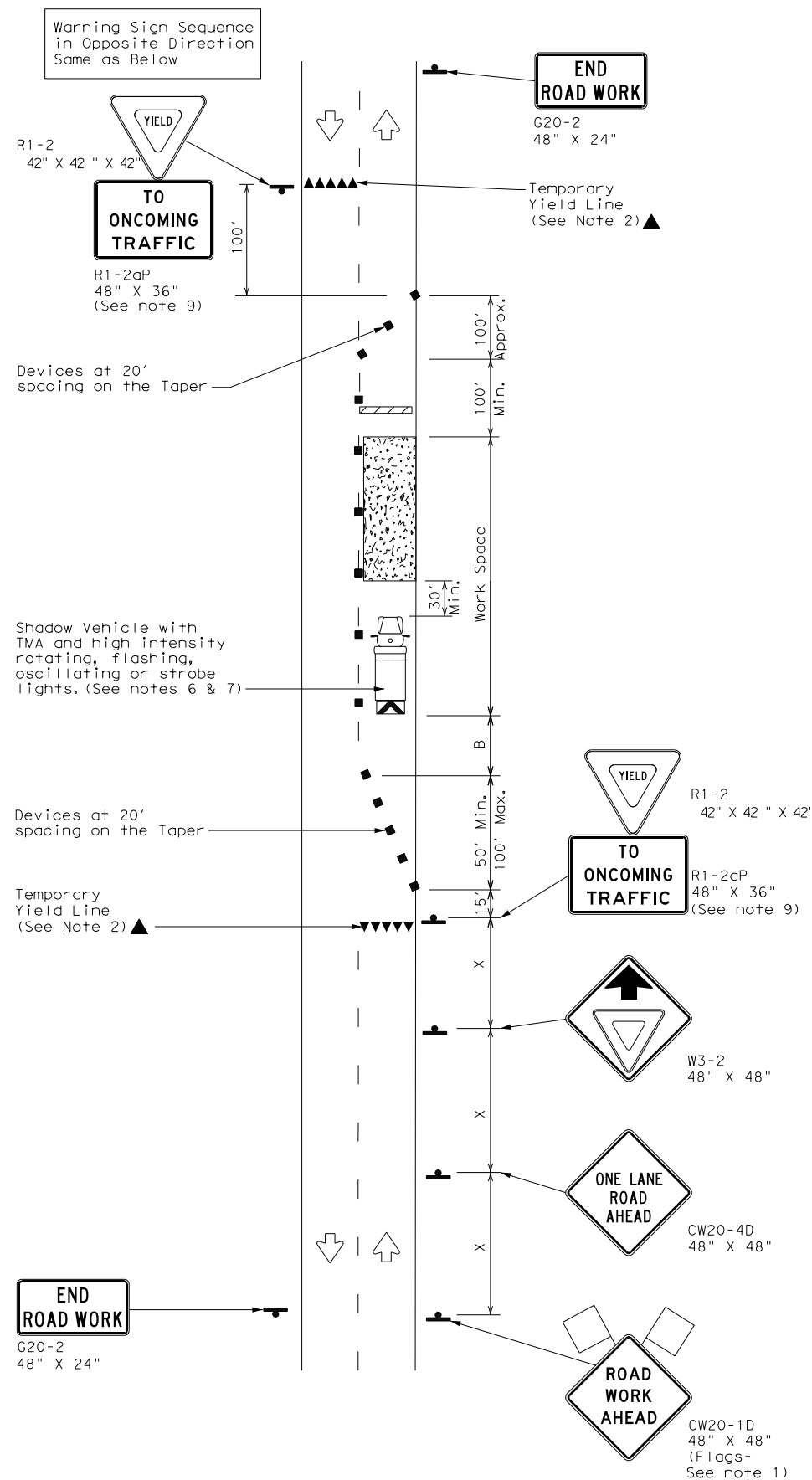

LEGEND

	Type 3 Barricade		Channelizing Devices
	Heavy Work Vehicle		Truck Mounted Attenuator (TMA)
	Trailer Mounted Flashing Arrow Board		Portable Changeable Message Sign (PCMS)
	Sign		Traffic Flow
	Flag		Flagger

Posted Speed *	Formula	Minimum Desirable Taper Lengths **			Suggested Maximum Spacing of Channelizing Devices		Minimum Sign Spacing "X" Distance	Suggested Longitudinal Buffer Space "B"	Stopping Sight Distance
		10' Offset	11' Offset	12' Offset	On a Taper	On a Tangent			
30	L = WS ² / 60	150'	165'	180'	30'	60'	120'	90'	200'
35		205'	225'	245'	35'	70'	160'	120'	250'
40		265'	295'	320'	40'	80'	240'	155'	305'
45	L = WS	450'	495'	540'	45'	90'	320'	195'	360'
50		500'	550'	600'	50'	100'	400'	240'	425'
55		550'	605'	660'	55'	110'	500'	295'	495'
60		600'	660'	720'	60'	120'	600'	350'	575'
65		650'	715'	780'	65'	130'	700'	410'	645'
70		700'	770'	840'	70'	140'	800'	475'	730'
75		750'	825'	900'	75'	150'	900'	540'	820'

* Conventional Roads Only
 ** Taper lengths have been rounded off.
 L=Length of Taper (FT) W=Width of Offset (FT) S=Posted Speed (MPH)

TYPICAL USAGE

MOBILE	SHORT DURATION	SHORT TERM STATIONARY	INTERMEDIATE TERM STATIONARY	LONG TERM STATIONARY
	✓	✓	✓	

GENERAL NOTES

- Flags attached to signs where shown, are REQUIRED.
- All traffic control devices illustrated are REQUIRED, except those denoted with the triangle symbol may be omitted when stated elsewhere in the plans, or for routine maintenance work, when approved by the Engineer.
- The CW3-4 "BE PREPARED TO STOP" sign may be installed after the CW20-4 "ONE LANE ROAD XXX FT" sign, but proper sign spacing shall be maintained.
- Flaggers should use two-way radios or other methods of communication to control traffic.
- Length of work space should be based on the ability of flaggers to communicate.
- A Shadow Vehicle with a TMA should be used anytime it can be positioned 30 to 100 feet in advance of the area of crew exposure without adversely affecting the performance or quality of the work. If workers are no longer present but road or work conditions require the traffic control to remain in place, Type 3 Barricades or other channelizing devices may be substituted for the Shadow Vehicle and TMA.
- Additional Shadow Vehicles with TMAs may be positioned off the paved surface, next to those shown in order to protect a wider work space.

TCP (2-2a)

- The R1-2 "YIELD" sign traffic control may be used on projects with approaches that have adequate sight distance. For projects in urban areas, work space should be no longer than one half city block. In rural areas, roadways with less than 2000 ADT, work space should be no longer than 400 feet.
- The R1-2aP "YIELD TO ONCOMING TRAFFIC" sign shall be placed on a support at a 7 foot minimum mounting height.

TCP (2-2b)

- Channelizing devices on the center line may be omitted when a pilot car is leading traffic and approved by the Engineer.
- If the work space is located near a horizontal or vertical curve, the buffer distances should be increased in order to maintain stopping sight distance to the flagger and a queue of stopped vehicles. (See table above).
- Flaggers should use 24" STOP/SLOW paddles to control traffic. Flags should be limited to emergency situations.



TRAFFIC CONTROL PLAN
ONE-LANE TWO-WAY
TRAFFIC CONTROL

TCP (2-2) - 18

FILE: tcp2-2-18.dgn	DN:	CK:	DW:	CK:
© TxDOT December 1985	CON:	SECT:	JOB:	HIGHWAY:
REVISIONS	091016	165	MLK JR	
8-95 3-03	DIST:	COUNTY:	SHEET NO.:	
1-97 2-12	TYLER	SMITH	22	
4-98 2-18				

DISCLAIMER: The use of this standard is governed by the "Texas Engineering Practice Act". No warranty of any kind is made by TxDOT for any purpose whatsoever. TxDOT assumes no responsibility for the conversion of this standard to other formats or for incorrect results or damages resulting from its use.

DATE: DATE TIME
FILE: DOCUMENT NAME

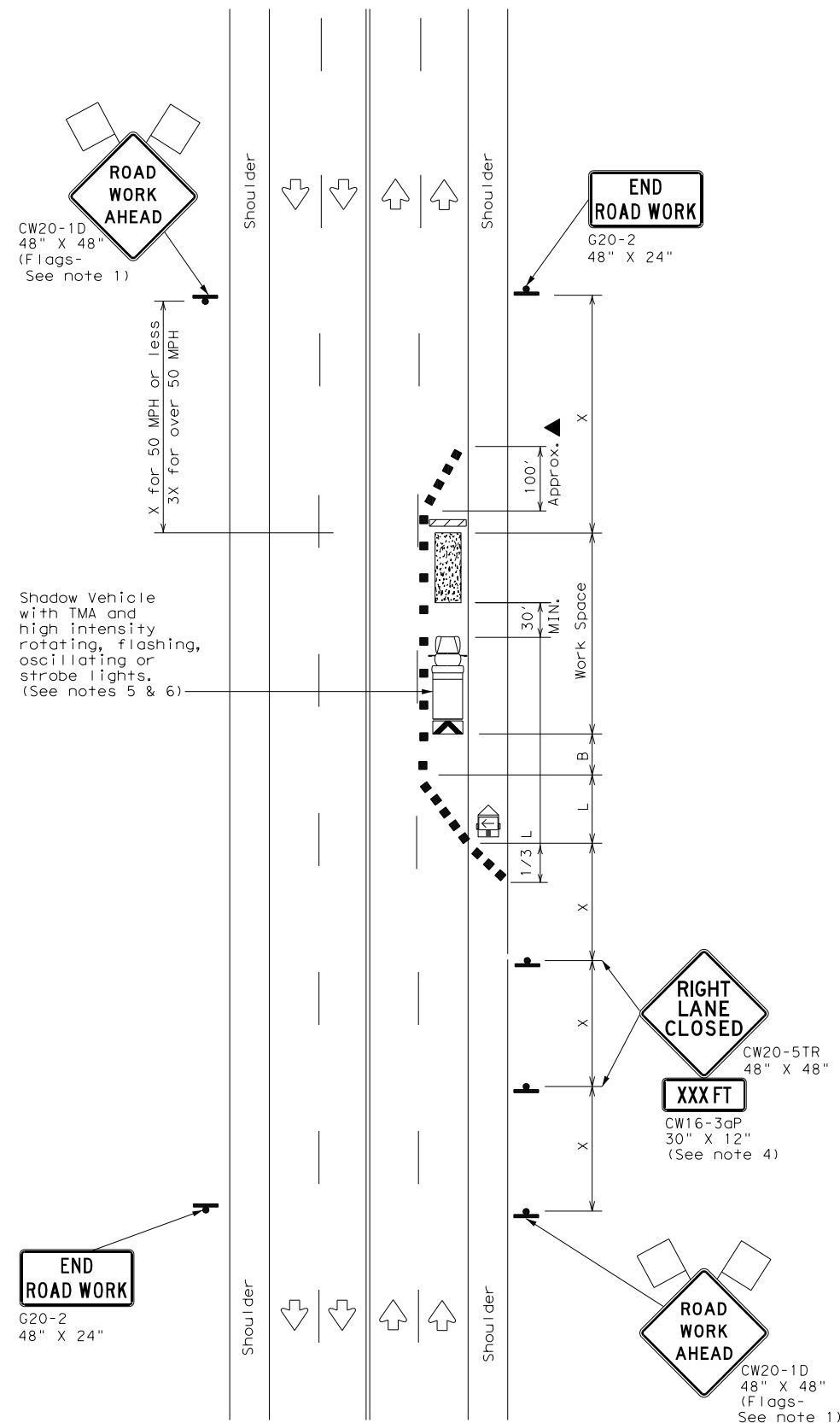

TCP (2-4a)

ONE LANE CLOSED

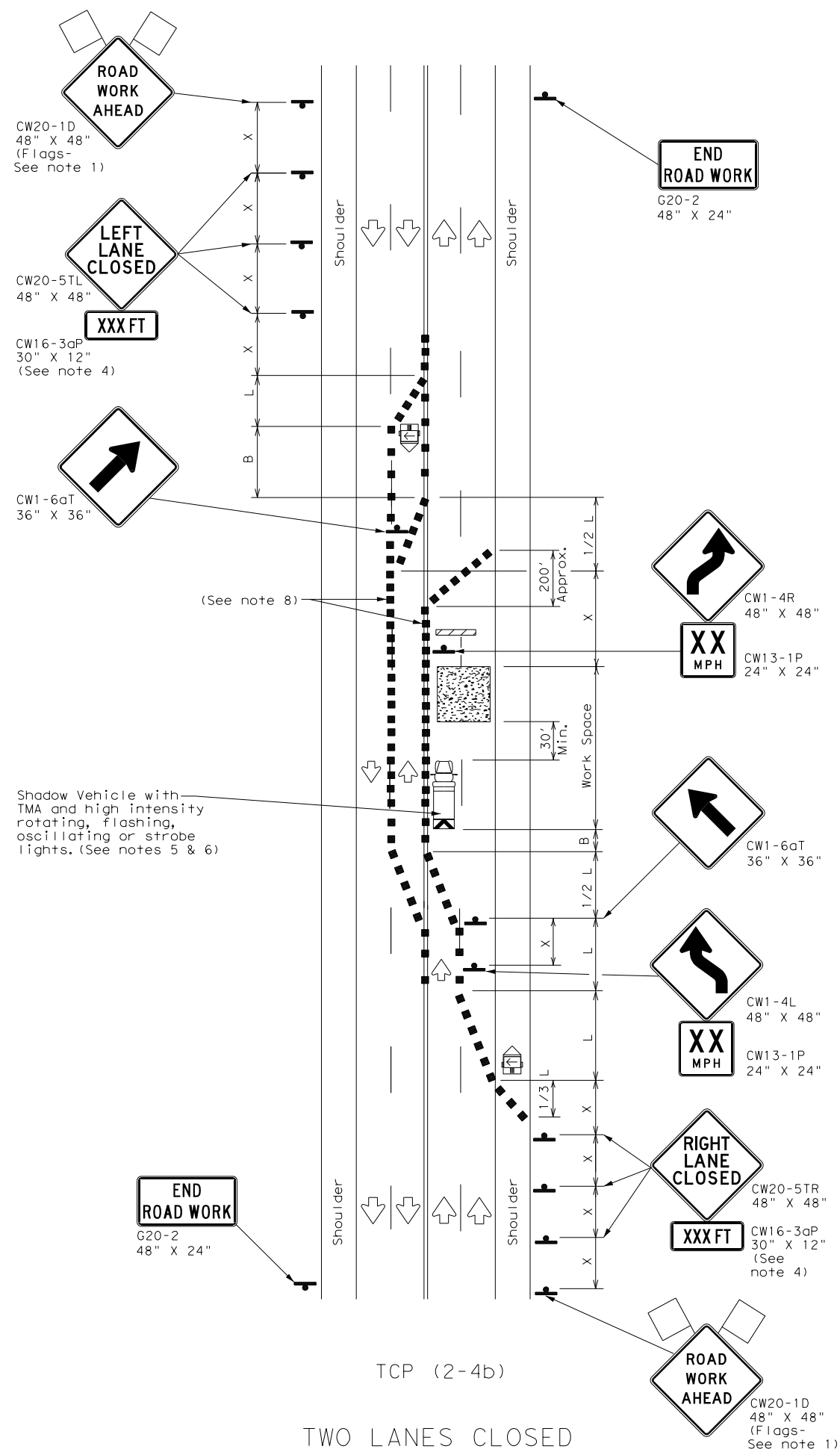

TCP (2-4b)

TWO LANES CLOSED

LEGEND			
	Type 3 Barricade		Channelizing Devices
	Heavy Work Vehicle		Truck Mounted Attenuator (TMA)
	Trailer Mounted Flashing Arrow Board		Portable Changeable Message Sign (PCMS)
	Sign		Traffic Flow
	Flag		Flagger

Posted Speed *	Formula	Minimum Desirable Taper Lengths **			Suggested Maximum Spacing of Channelizing Devices		Minimum Sign Spacing "x" Distance	Suggested Longitudinal Buffer Space "B"
		10' Offset	11' Offset	12' Offset	On a Taper	On a Tangent		
30	$L = \frac{WS^2}{60}$	150'	165'	180'	30'	60'	120'	90'
35		205'	225'	245'	35'	70'	160'	120'
40		265'	295'	320'	40'	80'	240'	155'
45	L = WS	450'	495'	540'	45'	90'	320'	195'
50		500'	550'	600'	50'	100'	400'	240'
55		550'	605'	660'	55'	110'	500'	295'
60		600'	660'	720'	60'	120'	600'	350'
65		650'	715'	780'	65'	130'	700'	410'
70		700'	770'	840'	70'	140'	800'	475'
75		750'	825'	900'	75'	150'	900'	540'

* Conventional Roads Only
 ** Taper lengths have been rounded off.
 L=Length of Taper (FT) W=Width of Offset (FT) S=Posted Speed (MPH)

TYPICAL USAGE				
MOBILE	SHORT DURATION	SHORT TERM STATIONARY	INTERMEDIATE TERM STATIONARY	LONG TERM STATIONARY
		✓	✓	

GENERAL NOTES

- Flags attached to signs where shown, are REQUIRED.
- All traffic control devices illustrated are REQUIRED, except those denoted with the triangle symbol may be omitted when stated elsewhere in the plans, or for routine maintenance work, when approved by the Engineer.
- The downstream taper is optional. When used, it should be 100 feet minimum length per lane.
- For short term applications, when post mounted signs are not used, the distance legend may be shown on the sign face rather than on a CW16-3aP supplemental plaque.
- A Shadow Vehicle with a TMA should be used anytime it can be positioned 30 to 100 feet in advance of the area of crew exposure without adversely affecting the performance or quality of the work. If workers are no longer present but road or work conditions require the traffic control to remain in place, Type 3 Barricades or other channelizing devices may be substituted for the Shadow Vehicle and TMA.
- Additional Shadow Vehicles with TMAs may be positioned in each closed lane, on the shoulder or off the paved surface, next to those shown in order to protect a wider work space.

TCP (2-4a)

- If this TCP is used for a left lane closure, CW20-5TL "LEFT LANE CLOSED" signs shall be used and channelizing devices shall be placed on the centerline to protect the work space from opposing traffic with the arrow board placed in the closed lane near the end of the merging taper.

TCP (2-4b)

- For shorter durations where traffic is directed over a yellow centerline, channelizing devices which separate two-way traffic should be spaced on tapers at 20' or 15' if posted speeds are 35 mph or slower, and for tangent sections, at 1/2(S) where S is the speed in mph. This tighter devices spacing is intended for the area of conflicting markings, not the entire work zone.



TRAFFIC CONTROL PLAN
 LANE CLOSURES ON MULTILANE
 CONVENTIONAL ROADS

TCP (2-4) - 18

FILE: tcp2-4-18.dgn	DN:	CK:	DW:	CK:
© TxDOT December 1985	CON:	SECT:	JOB:	HIGHWAY:
REVISIONS	091016	165	MLK JR	
8-95 3-03	DIST:	COUNTY:	SHEET NO.:	
1-97 2-12	TYLER	SMITH	23	
4-98 2-18				

DISCLAIMER: The use of this standard is governed by the "Texas Engineering Practice Act". No warranty of any kind is made by TxDOT for any purpose whatsoever. TxDOT assumes no responsibility for the conversion of this standard to other formats or for incorrect results or damages resulting from its use.

DATE: FILE:

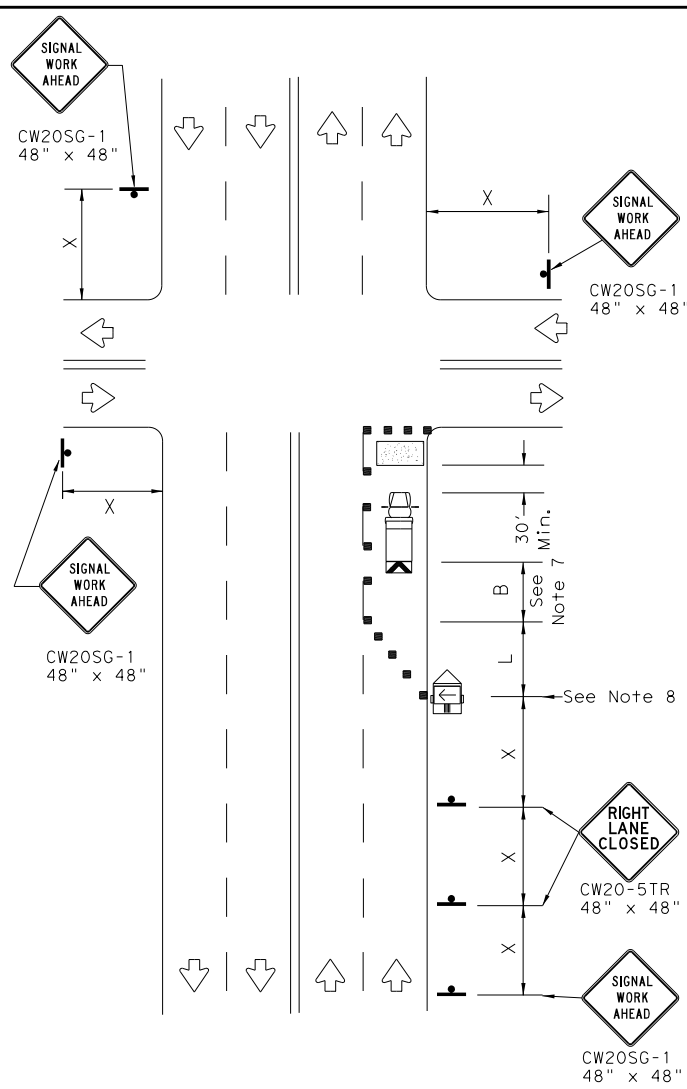

NEAR SIDE LANE CLOSURE
SHORT DURATION OR SHORT TERM STATIONARY

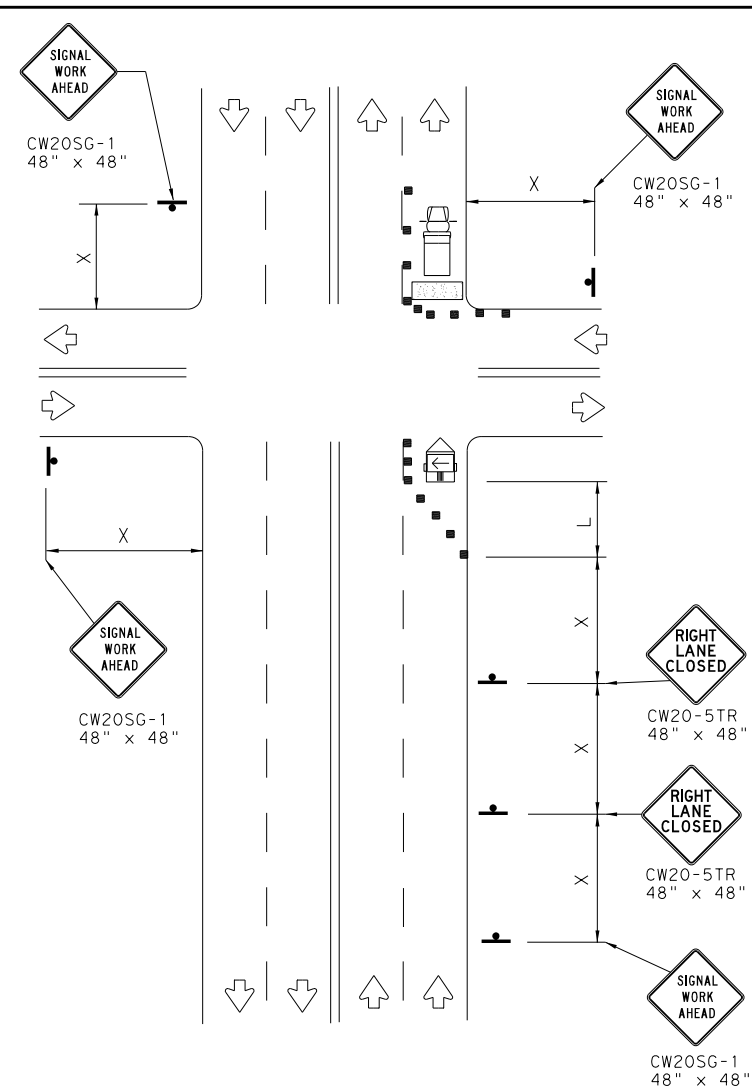

FAR SIDE RIGHT LANE CLOSURE
SHORT DURATION OR SHORT TERM STATIONARY

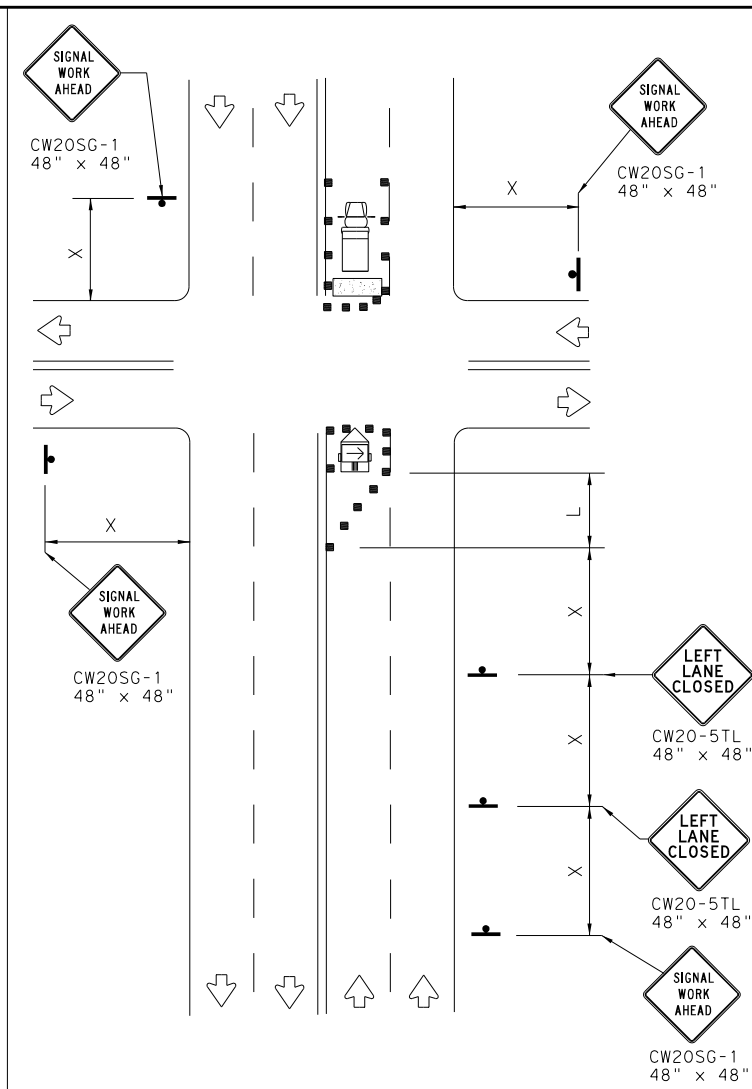

FAR SIDE LEFT LANE CLOSURE
SHORT DURATION OR SHORT TERM STATIONARY

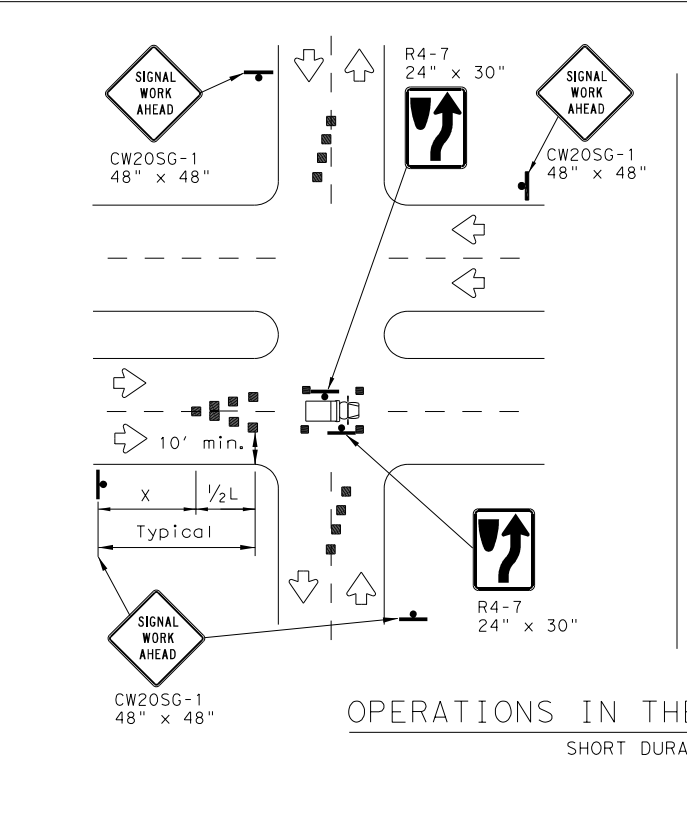

OPERATIONS IN THE INTERSECTION
SHORT DURATION

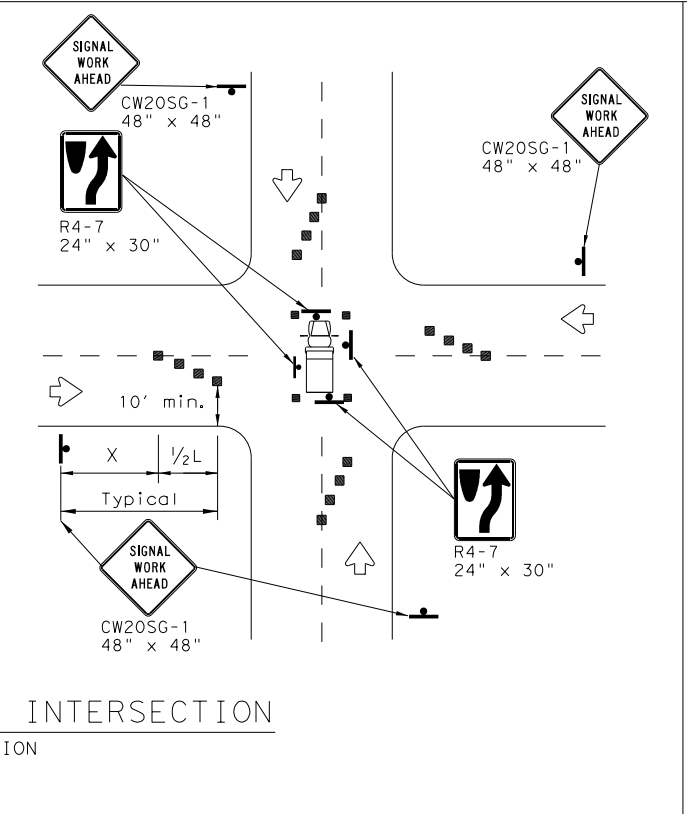

GENERAL NOTES

- The minimum size channelizing device is the 28" cone. 42" Two-piece cones, drums, vertical panels or barricades will be required when the device must be left unattended at night.
- Obstructions or hazards at the work area shall be clearly marked and delineated at all times.
- Flaggers and Flagger Symbol (CW20-7) signs may be required according to field conditions.
- Vehicles parked in roadway shall be equipped with at least two high intensity rotating, flashing, oscillating or strobe type lights.
- High level warning devices (flag trees) may be used at corners of the vehicle.
- When work operations are performed on existing signals, the signals may be placed in flashing red mode when approved by the engineer. If existing signals do not have power, All-Way Stop (R1-1 and R1-3P) signs may be implemented when approved by the engineer.
- For Short-Term Stationary work the buffer space "B" from the above table should be used if field conditions permit. For Short Duration (less than 1 hour) any buffer space provided will enhance the safety of the setup.
- The arrow board at this location may be omitted for Short Duration work if the work vehicle has an arrow board in operation. As an option, the arrow board may be placed at the end of the taper in the closed lane if space is not available at the beginning of the taper.
- Signs and devices for the NEAR SIDE LANE CLOSURE may be altered for a left lane closure by using a LEFT LANE CLOSED (CW20-5TL) and adding channelizing devices on the centerline to protect the work space from opposing traffic.

LEGEND

	Type 3 Barricade		Channelizing Devices
	Heavy Work Vehicle		Truck Mounted Attenuator (TMA)
	Trailer Mounted Flashing Arrow Board		Portable Changeable Message Sign (PCMS)
	Sign		Traffic Flow
	Flag		Flagger

Posted Speed *	Formula	Minimum Desirable Taper Lengths **			Suggested Maximum Spacing of Channelizing Devices		Minimum Sign Spacing "x" Distance	Suggested Longitudinal Buffer Space "B"
		10' Offset	11' Offset	12' Offset	On a Taper	On a Tangent		
30	$L = \frac{WS^2}{60}$	150'	165'	180'	30'	60'	120'	90'
35		205'	225'	245'	35'	70'	160'	120'
40		265'	295'	320'	40'	80'	240'	155'
45	L = WS	450'	495'	540'	45'	90'	320'	195'
50		500'	550'	600'	50'	100'	400'	240'
55		550'	605'	660'	55'	110'	500'	295'
60		600'	660'	720'	60'	120'	600'	350'
65		650'	715'	780'	65'	130'	700'	410'
70		700'	770'	840'	70'	140'	800'	475'
75		750'	825'	900'	75'	150'	900'	540'

* Conventional Roads Only
 ** Taper lengths have been rounded off.
 L=Length of Taper (FT) W=Width of Offset (FT) S=Posted Speed (MPH)

WORKERS IN BUCKET TRUCKS SHALL NOT WORK ABOVE OPEN LANES OF TRAFFIC.



TRAFFIC SIGNAL WORK TYPICAL DETAILS

WZ(BTS-1)-13

FILE: wzbts-13.dgn	DN: TxDOT	CK: TxDOT	DW: TxDOT	CK: TxDOT
© TxDOT April 1992	CONT	SECT	JOB	HIGHWAY
REVISIONS	0910	16	165	MLK JR
2-98 10-99 7-13	DIST	COUNTY	SHEET NO.	
4-98 3-03	TYLER	SMITH	24	

DISCLAIMER: The use of this standard is governed by the "Texas Engineering Practice Act". No warranty of any kind is made by TxDOT for any purpose whatsoever. TxDOT assumes no responsibility for the conversion of this standard to other formats or for incorrect use or damages resulting from its use.

DATE: FILE:

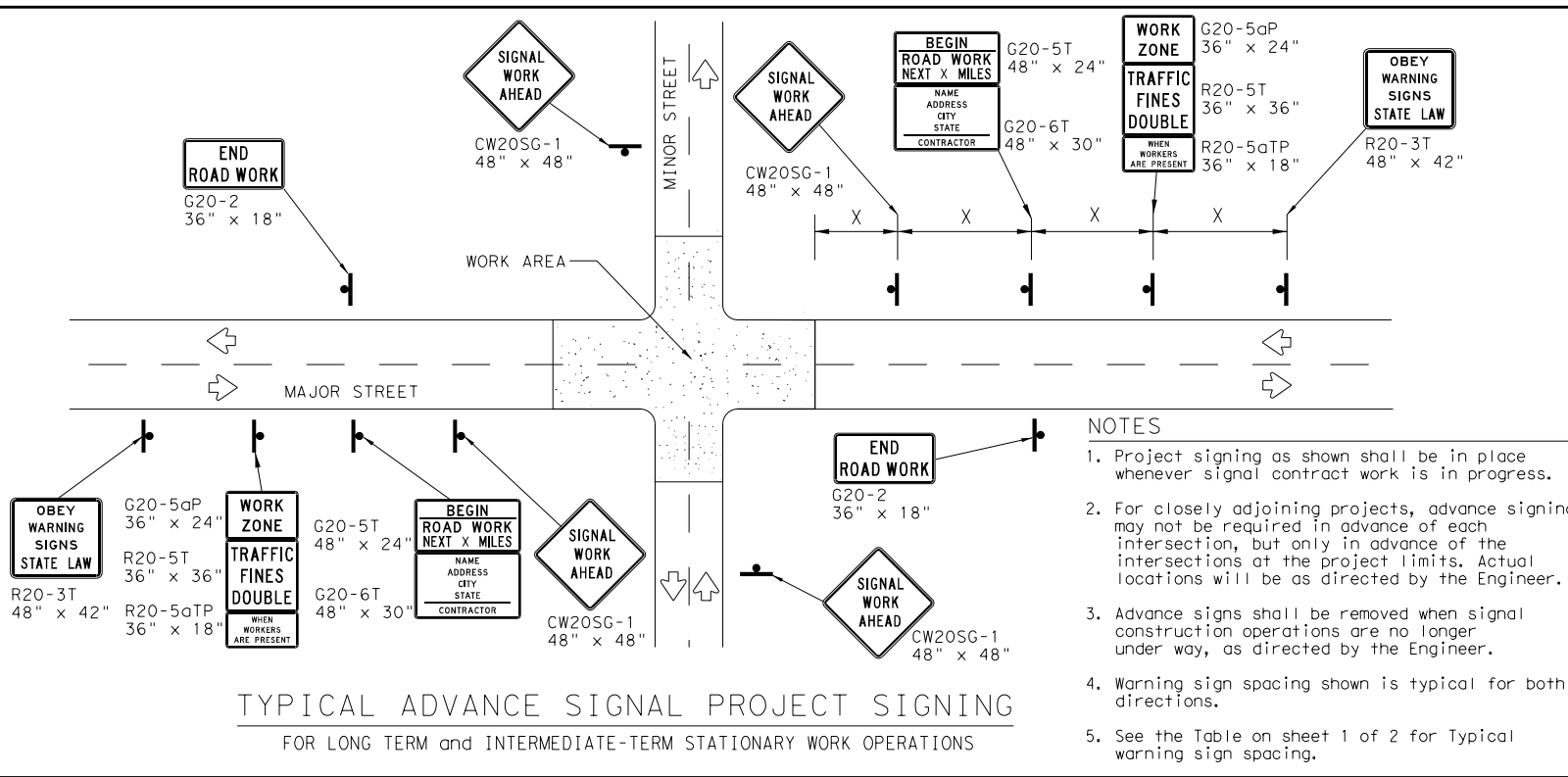

- NOTES**
- Project signing as shown shall be in place whenever signal contract work is in progress.
 - For closely adjoining projects, advance signing may not be required in advance of each intersection, but only in advance of the intersections at the project limits. Actual locations will be as directed by the Engineer.
 - Advance signs shall be removed when signal construction operations are no longer under way, as directed by the Engineer.
 - Warning sign spacing shown is typical for both directions.
 - See the Table on sheet 1 of 2 for Typical warning sign spacing.

GENERAL NOTES FOR WORK ZONE SIGNS

- Signs shall be installed and maintained in a straight and plumb condition.
- Wooden sign posts shall be painted white.
- Barricades shall NOT be used as sign supports.
- Nails shall NOT be used to attach signs to any support.
- All signs shall be installed in accordance with the plans or as directed by the Engineer.
- The Contractor shall furnish the sign design shown in the plans or in the "Standard Highway Sign Designs for Texas" (SHSD).
- The Contractor shall furnish sign supports and substrates listed in the "Compliant Work Zone Traffic Control Device List" (CWZTCD), installed as per the manufacturer's recommendations.
- Temporary signs that have damaged or cracked substrates and/or damaged or marred reflective sheeting shall be replaced as directed by the Engineer.
- Identification markings may be shown only on the back of the sign substrate. The maximum height of letters and/or company logos used for identification shall be 1".
- Damaged wood posts shall be replaced. Splicing wood posts will not be allowed.

DURATION OF WORK

- Work zone durations are defined in Part 6, Section 6G.02 of the Texas Manual on Uniform Traffic Control Devices (TMUTCD).

SIGN MOUNTING HEIGHT

- Sign height of Long-term/Intermediate-term warning signs shall be as shown on Figure 6F-1 of the TMUTCD.
- Sign height of Short-term/Short Duration warning signs shall be as shown on Figure 6F-2 of the TMUTCD.
- Regulatory signs shall be mounted at least 7 feet, but not more than 9 feet, above the paved surface regardless of work duration.

REMOVING OR COVERING

- When sign messages may be confusing or do not apply, the signs shall be removed or completely covered, unless otherwise approved by the Engineer.
- When signs are covered, the material used shall be opaque, such as heavy mil black plastic, or other materials which will cover the entire sign face and maintain their opaque properties under automobile headlights at night without damaging the sign sheeting. Burlap, or heavy materials such as plywood or aluminum shall not be used to cover signs.
- Duct tape or other adhesive material shall NOT be affixed to a sign face.
- Signs and anchor stubs shall be removed and holes backfilled upon completion of the work.

REFLECTIVE SHEETING

- All signs shall be retroreflective and constructed of sheeting meeting the requirements of the DMS and color usage table shown on this sheet.

SIGN SUPPORT WEIGHTS

- Weights used to keep signs from turning over should be sandbags filled with dry, cohesionless material.
- The sandbags will be tied shut to keep the sand from spilling and to maintain a constant weight.
- Rock, concrete, iron, steel or other solid objects will not be permitted for use as sign support weights.
- Sandbags should weigh a minimum of 35 lbs and a maximum of 50 lbs.
- Sandbags shall be made of a durable material that tears upon vehicular impact. Rubber, such as tire inner tubes, shall not be used.
- Rubber ballasts designed for channelizing devices should not be used for ballast on portable sign supports. Sign supports designed and manufactured with rubber bases may be used when shown on the CWZTCD list.
- Sandbags shall only be placed along or laid over the base supports of the traffic control device and shall not be suspended above ground level or hung with rope, wire, chains or other fasteners. Sandbags shall be placed along the length of the skids to weigh down the sign support.
- Sandbags shall NOT be placed under the skid and shall not be used to level sign supports placed on slopes.

LEGEND	
	Sign
	Channelizing Devices
	Type 3 Barricade

DEPARTMENTAL MATERIAL SPECIFICATIONS	
SIGN FACE MATERIALS	DMS-8300
FLEXIBLE ROLL-UP REFLECTIVE SIGNS	DMS-8310

COLOR	USAGE	SHEETING MATERIAL
ORANGE	BACKGROUND	TYPE B _{FL} OR TYPE C _{FL} SHEETING
WHITE	BACKGROUND	TYPE A SHEETING
BLACK	LEGEND & BORDERS	ACRYLIC NON-REFLECTIVE SHEETING

Only pre-qualified products shall be used. A copy of the "Compliant Work Zone Traffic Control Devices List" (CWZTCD) describes pre-qualified products and their sources and may be found at the following web address:
http://www.txdot.gov/txdot_library/publications/construction.htm

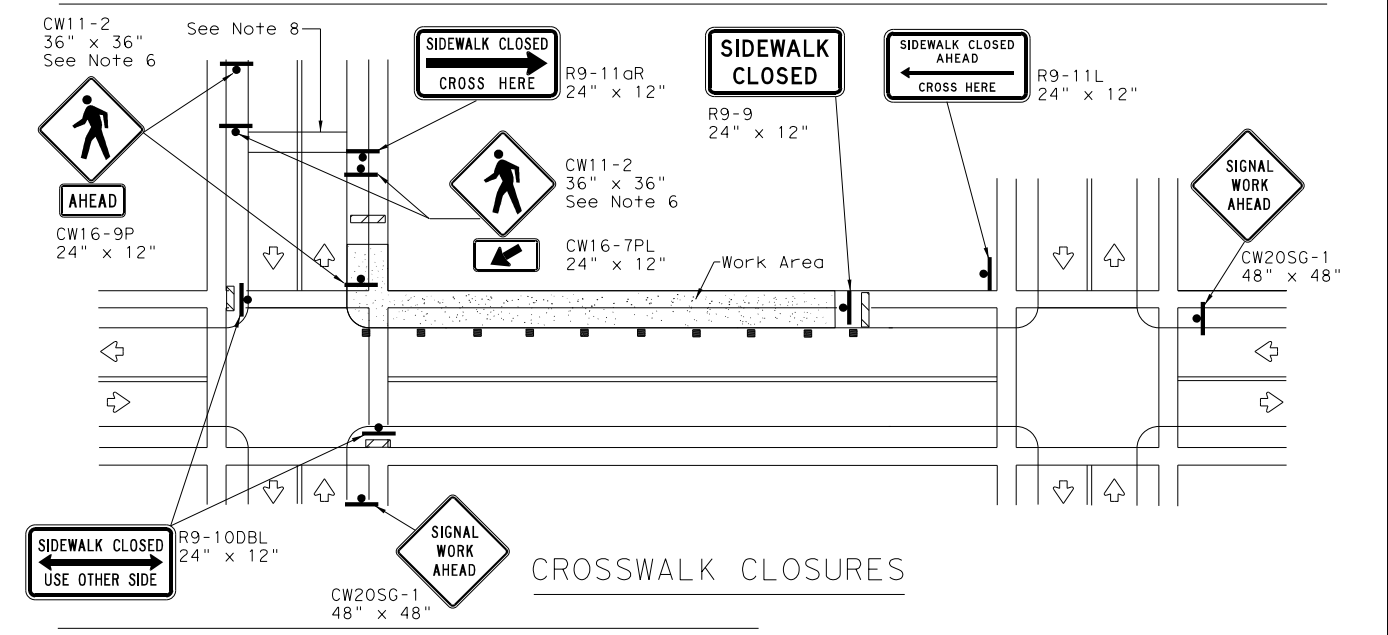
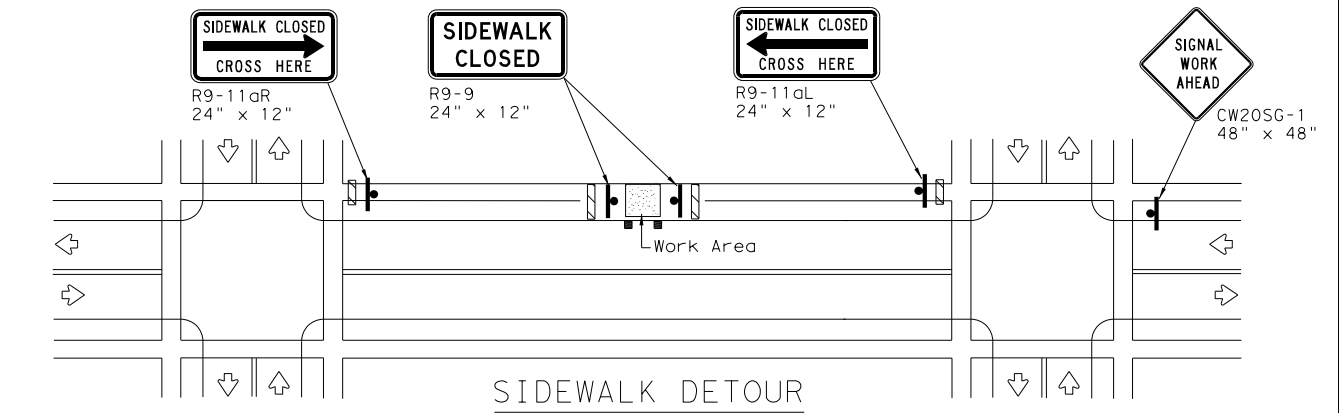
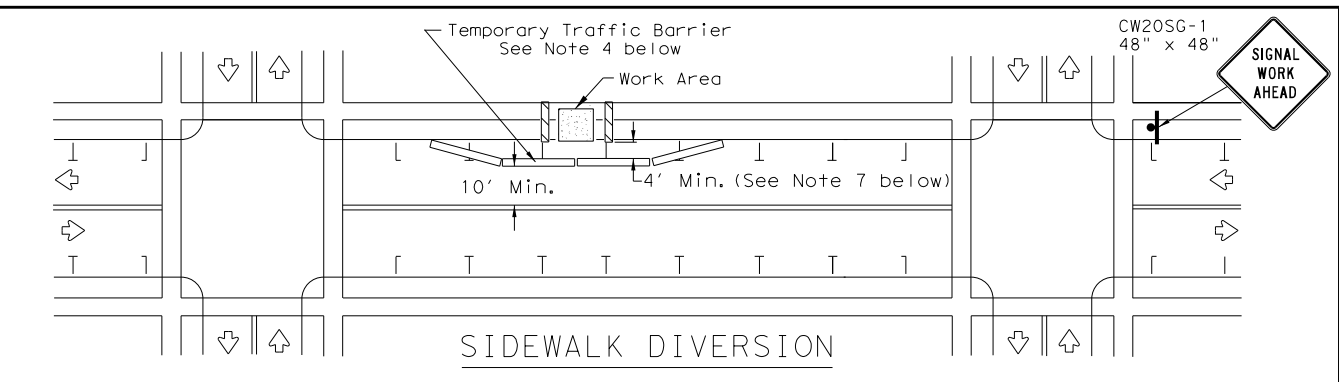

PEDESTRIAN CONTROL

- Holes, trenches or other hazards shall be adequately protected by covering, delineating or surrounding the hazard with orange plastic pedestrian fencing or longitudinal channelizing devices, or as directed by the Engineer.
- "CROSSWALK CLOSURES" as detailed above will require the Engineer's approval prior to installation.
- R9 series signs shown may be placed on supports detailed on the BC standards or CWZTCD list, or when fabricated from approved lightweight plastic substrates, they may be mounted on top of a plastic drum at or near the location shown.
- For speeds less than 45 mph longitudinal channelizing devices may be used instead of traffic barriers when approved by the Engineer. Attenuation of blunt ends and installation of water filled devices shall be as per BC(9) and manufacturer's recommendations.
- Location of devices are for general guidance. Actual device spacing and location must be field adjusted to meet actual conditions.
- Where pedestrians with visual disabilities normally use the closed sidewalk Detectable Pedestrian Barricades should be used instead of the Type 3 Barricades shown.
- The width of existing sidewalk should be maintained if practical.
- Pavement markings for mid-block crosswalks shall be paid for under the appropriate bid items.
- When crosswalks or other pedestrian facilities are closed or relocated, temporary facilities shall be detectable and shall include accessibility features consistent with the features present in the existing pedestrian facility.

SHEET 2 OF 2









TRAFFIC SIGNAL WORK BARRICADES AND SIGNS

WZ(BTS-2) - 13

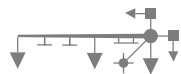
FILE: wzbts-13.dgn	DN: TxDOT	CK: TxDOT	DW: TxDOT	CK: TxDOT
© TxDOT April 1992	CONT	SECT	JOB	HIGHWAY
REVISIONS	0910	16	165	MLK JR
2-98 10-99 7-13	DIST	COUNTY	SHEET NO.	
4-98 3-03	TYLER	SMITH	25	



LEGEND

-  EXISTING TYPICAL MAST ARM COMBINATION SIGNAL \ WITH PEDESTRIAN SIGNAL, PUSH BUTTON, LED LUMINAIRE, AND SIGNAGE
-  EXISTING TRAFFIC SIGNAL CONTROLLER CABINET
-  EXISTING GROUND BOX
-  EXISTING CONDUIT
-  EXISTING ELECTRICAL SERVICE
-  E-# EXISTING TRAFFIC SIGNAL POLE NUMBER
-  PROPOSED CELLULAR WIRELESS COMMUNICATION

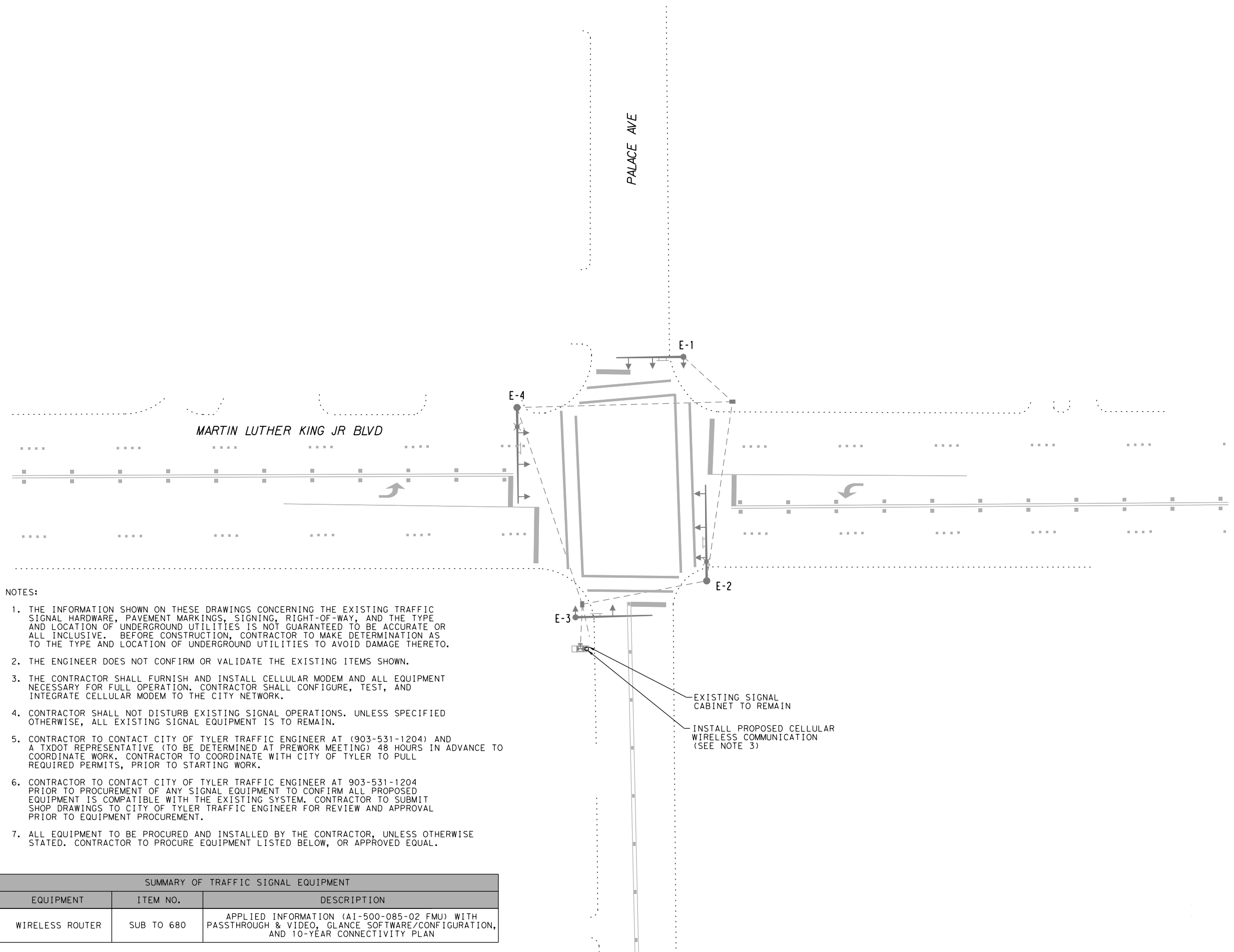

NOTES:

1. THE INFORMATION SHOWN ON THESE DRAWINGS CONCERNING THE EXISTING TRAFFIC SIGNAL HARDWARE, PAVEMENT MARKINGS, SIGNING, RIGHT-OF-WAY, AND THE TYPE AND LOCATION OF UNDERGROUND UTILITIES IS NOT GUARANTEED TO BE ACCURATE OR ALL INCLUSIVE. BEFORE CONSTRUCTION, CONTRACTOR TO MAKE DETERMINATION AS TO THE TYPE AND LOCATION OF UNDERGROUND UTILITIES TO AVOID DAMAGE THERETO.
2. THE ENGINEER DOES NOT CONFIRM OR VALIDATE THE EXISTING ITEMS SHOWN.
3. THE CONTRACTOR SHALL FURNISH AND INSTALL CELLULAR MODEM AND ALL EQUIPMENT NECESSARY FOR FULL OPERATION. CONTRACTOR SHALL CONFIGURE, TEST, AND INTEGRATE CELLULAR MODEM TO THE CITY NETWORK.
4. CONTRACTOR SHALL NOT DISTURB EXISTING SIGNAL OPERATIONS. UNLESS SPECIFIED OTHERWISE, ALL EXISTING SIGNAL EQUIPMENT IS TO REMAIN.
5. CONTRACTOR TO CONTACT CITY OF TYLER TRAFFIC ENGINEER AT (903-531-1204) AND A TXDOT REPRESENTATIVE (TO BE DETERMINED AT PREWORK MEETING) 48 HOURS IN ADVANCE TO COORDINATE WORK. CONTRACTOR TO COORDINATE WITH CITY OF TYLER TO PULL REQUIRED PERMITS, PRIOR TO STARTING WORK.
6. CONTRACTOR TO CONTACT CITY OF TYLER TRAFFIC ENGINEER AT 903-531-1204 PRIOR TO PROCUREMENT OF ANY SIGNAL EQUIPMENT TO CONFIRM ALL PROPOSED EQUIPMENT IS COMPATIBLE WITH THE EXISTING SYSTEM. CONTRACTOR TO SUBMIT SHOP DRAWINGS TO CITY OF TYLER TRAFFIC ENGINEER FOR REVIEW AND APPROVAL PRIOR TO EQUIPMENT PROCUREMENT.
7. ALL EQUIPMENT TO BE PROCURED AND INSTALLED BY THE CONTRACTOR, UNLESS OTHERWISE STATED. CONTRACTOR TO PROCURE EQUIPMENT LISTED BELOW, OR APPROVED EQUAL.

EXISTING SIGNAL CABINET TO REMAIN
 INSTALL PROPOSED CELLULAR WIRELESS COMMUNICATION (SEE NOTE 3)

SUMMARY OF TRAFFIC SIGNAL EQUIPMENT

EQUIPMENT	ITEM NO.	DESCRIPTION
WIRELESS ROUTER	SUB TO 680	APPLIED INFORMATION (AI-500-085-02 FMU) WITH PASSTHROUGH & VIDEO, GLANCE SOFTWARE/CONFIGURATION, AND 10-YEAR CONNECTIVITY PLAN

5/13/2022



Kimley»Horn

13455 Noel Road
 Two Galleria Office Tower, Suite 700
 Dallas, Texas 75240
 Tel. No. (972) 770-1300
 Fax No. (972) 239-3820



CITY OF TYLER

 Texas Department of Transportation
 © 2022

**TRAFFIC SAFETY IMPROVEMENTS
 PROPOSED CONDITIONS**

**W. MLK JR. BOULEVARD
 AT PALACE AVENUE**

DESIGN	FED. RD. DIV. NO.	FEDERAL AID PROJECT NO.	HIGHWAY NO.
HMF	6	(SEE TITLE SHEET)	CS
GRAPHICS	STATE	DISTRICT	COUNTY
MB	TEXAS	TYLER	SMITH
CHECK	CONTROL	SECTION	JOB
ASA	0910	16	165
CHECK			
HMF			

26

PLOTTED: 5/13/2022 4:00:00 PM / in. FILENAME: K:\DAL_TPTO\project\063615008 - Tyler HSIP PS&E\CADD\TYL-HSIP_T1_011_MLK at Palace_Proposed.dgn

EXISTING SIGNALS

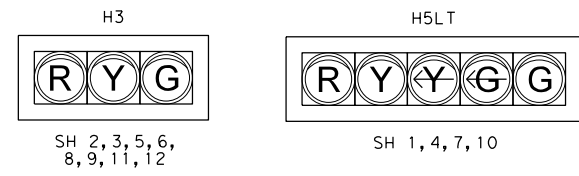

EXISTING SIGNS



LEGEND

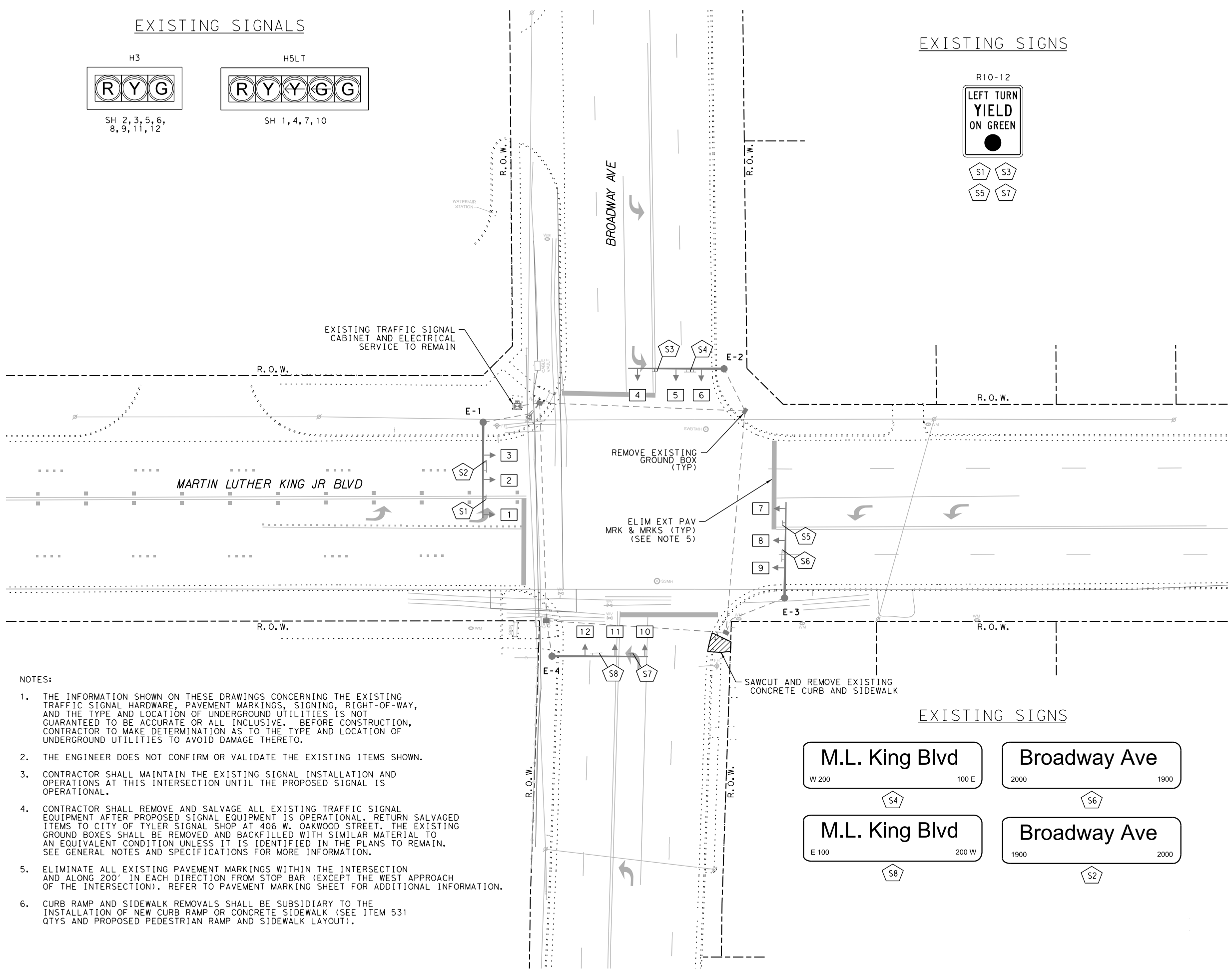
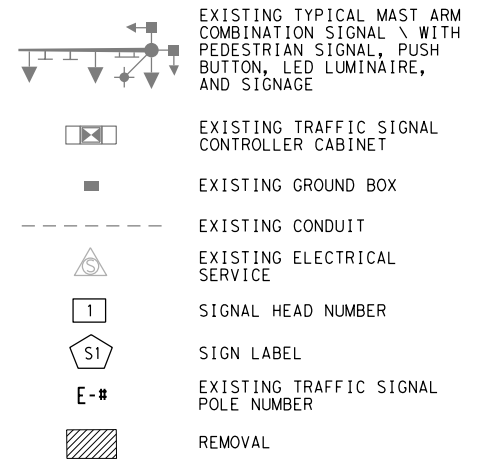

- NOTES:
1. THE INFORMATION SHOWN ON THESE DRAWINGS CONCERNING THE EXISTING TRAFFIC SIGNAL HARDWARE, PAVEMENT MARKINGS, SIGNING, RIGHT-OF-WAY, AND THE TYPE AND LOCATION OF UNDERGROUND UTILITIES IS NOT GUARANTEED TO BE ACCURATE OR ALL INCLUSIVE. BEFORE CONSTRUCTION, CONTRACTOR TO MAKE DETERMINATION AS TO THE TYPE AND LOCATION OF UNDERGROUND UTILITIES TO AVOID DAMAGE THERETO.
 2. THE ENGINEER DOES NOT CONFIRM OR VALIDATE THE EXISTING ITEMS SHOWN.
 3. CONTRACTOR SHALL MAINTAIN THE EXISTING SIGNAL INSTALLATION AND OPERATIONS AT THIS INTERSECTION UNTIL THE PROPOSED SIGNAL IS OPERATIONAL.
 4. CONTRACTOR SHALL REMOVE AND SALVAGE ALL EXISTING TRAFFIC SIGNAL EQUIPMENT AFTER PROPOSED SIGNAL EQUIPMENT IS OPERATIONAL. RETURN SALVAGED ITEMS TO CITY OF TYLER SIGNAL SHOP AT 406 W. OAKWOOD STREET. THE EXISTING GROUND BOXES SHALL BE REMOVED AND BACKFILLED WITH SIMILAR MATERIAL TO AN EQUIVALENT CONDITION UNLESS IT IS IDENTIFIED IN THE PLANS TO REMAIN. SEE GENERAL NOTES AND SPECIFICATIONS FOR MORE INFORMATION.
 5. ELIMINATE ALL EXISTING PAVEMENT MARKINGS WITHIN THE INTERSECTION AND ALONG 200' IN EACH DIRECTION FROM STOP BAR (EXCEPT THE WEST APPROACH OF THE INTERSECTION). REFER TO PAVEMENT MARKING SHEET FOR ADDITIONAL INFORMATION.
 6. CURB RAMP AND SIDEWALK REMOVALS SHALL BE SUBSIDIARY TO THE INSTALLATION OF NEW CURB RAMP OR CONCRETE SIDEWALK (SEE ITEM 531 QTY'S AND PROPOSED PEDESTRIAN RAMP AND SIDEWALK LAYOUT).

5/13/2022

Kimley»Horn F-928
 13455 Noel Road
 Two Galleria Office Tower, Suite 700
 Dallas, Texas 75240
 Tel. No. (972) 770-1300
 Fax No. (972) 239-3820

Texas Department of Transportation
 © 2022

TRAFFIC SAFETY IMPROVEMENTS
 EXISTING CONDITIONS
 AND REMOVALS
 W. MLK JR. BOULEVARD
 AT BROADWAY AVENUE



PLOTTED: 5/13/2022
 FILENAME: K:\DAL_TPTO\project\063615008 - Tyler_HSP_P&E\CADD\TYL-HS_IP_T1_021_MLK of Broadway_Ext.st.dgn
 BY: Marianne Borrego
 40,0024 ft / in.

DESIGN	FED. RD. DIV. NO.	FEDERAL AID PROJECT NO.	HIGHWAY NO.
HMF	6	(SEE TITLE SHEET)	CS
GRAPHICS	STATE	DISTRICT	COUNTY
MB	TEXAS	TYLER	SMITH
CHECK	CONTROL	SECTION	JOB
ASA	0910	16	165
CHECK			
HMF			27

PROPOSED SIGNS

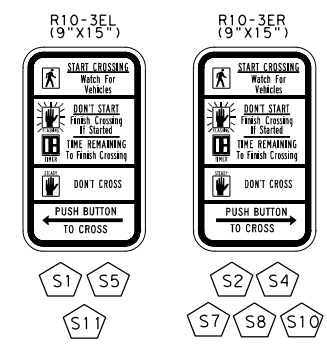

PROPOSED SIGNALS

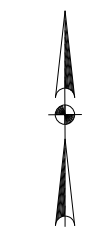

LEGEND

- EXISTING TYPICAL MAST ARM COMBINATION SIGNAL \ WITH PEDESTRIAN SIGNAL, PUSH BUTTON, LED LUMINAIRE, AND SIGNAGE
- EXISTING TRAFFIC SIGNAL CONTROLLER CABINET
- EXISTING GROUND BOX
- EXISTING CONDUIT
- EXISTING ELECTRICAL SERVICE
- CONDUIT RUN NUMBER
- SIGNAL HEAD NUMBER
- SIGN LABEL
- PROPOSED PEDESTRIAN POLE
- PROPOSED CONDUIT
- PROPOSED TYPE D GROUND BOX W/ APRON
- PROPOSED VIVDS DETECTOR AND LABEL
- PROPOSED CELLULAR WIRELESS COMMUNICATION
- EXISTING TRAFFIC SIGNAL POLE NUMBER
- PROPOSED TRAFFIC SIGNAL POLE NUMBER

NOTES CONTINUED:

10. PROPOSED APS UNITS SHALL BE PLACED ADJACENT TO A LEVEL LANDING AREA (2% MAX IN ANY DIRECTION). IF THE DISTANCE FROM THE PUSH BUTTON TO THE EDGE OF ACCESSIBLE PATH EXCEEDS 10", THE CONTRACTOR SHALL FURNISH AND INSTALL A PUSH BUTTON EXTENDER TO MAKE THE REACH 10" OR LESS. MEASUREMENT AND PAYMENT SHALL BE CONSIDERED SUBSIDIARY TO THE INSTALLATION OF THE TRAFFIC SIGNAL EQUIPMENT.
11. IF SIGNAL POLES CANNOT BE INSTALLED IN THE LOCATIONS SHOWN ON THE PLANS, THE CONTRACTOR SHALL CONTACT THE CITY AND ENGINEER TO MEET ON SITE TO DISCUSS NEW LOCATIONS.
12. PROPOSED CURB RAMP LANDING SHALL BE POURED UP TO THE SIGNAL FOUNDATION, LEAVING NO GAPS.

NOTES CONTINUED:

13. CONTRACTOR TO MAINTAIN FULL ACCESS TO A MINIMUM OF TWO PEDESTRIAN CROSSINGS AT ALL TIMES DURING CONSTRUCTION.
14. CONTRACTOR TO CONTACT CITY OF TYLER TRAFFIC ENGINEER AT 903-531-1204 PRIOR TO PROCUREMENT OF ANY SIGNAL EQUIPMENT TO CONFIRM ALL PROPOSED EQUIPMENT IS COMPATIBLE WITH THE EXISTING SYSTEM. CONTRACTOR TO SUBMIT SHOP DRAWINGS TO CITY OF TYLER TRAFFIC ENGINEER FOR REVIEW AND APPROVAL PRIOR TO EQUIPMENT PROCUREMENT.
15. CONTRACTOR TO REMOVE EXISTING GROUND BOX AND INSTALL NEW TYPE D GROUND BOX DIRECTLY ON TOP OF OLD GROUND BOX (TYPICAL).
16. ALL EQUIPMENT TO BE PROCURED AND INSTALLED BY THE CONTRACTOR, UNLESS OTHERWISE STATED. CONTRACTOR TO PROCURE EQUIPMENT LISTED BELOW, OR APPROVED EQUAL.

SUMMARY OF TRAFFIC SIGNAL EQUIPMENT		
EQUIPMENT	ITEM NO.	DESCRIPTION
DETECTION	6306	ITERIS VANTAGE VECTOR/NEXT
WIRELESS ROUTER	SUB TO 680	APPLIED INFORMATION (AI-500-085-02 FMU) WITH PASSTHROUGH & VIDEO, GLANCE SOFTWARE/CONFIGURATION, AND 10-YEAR CONNECTIVITY PLAN
APS	688	POLARA I-NAV

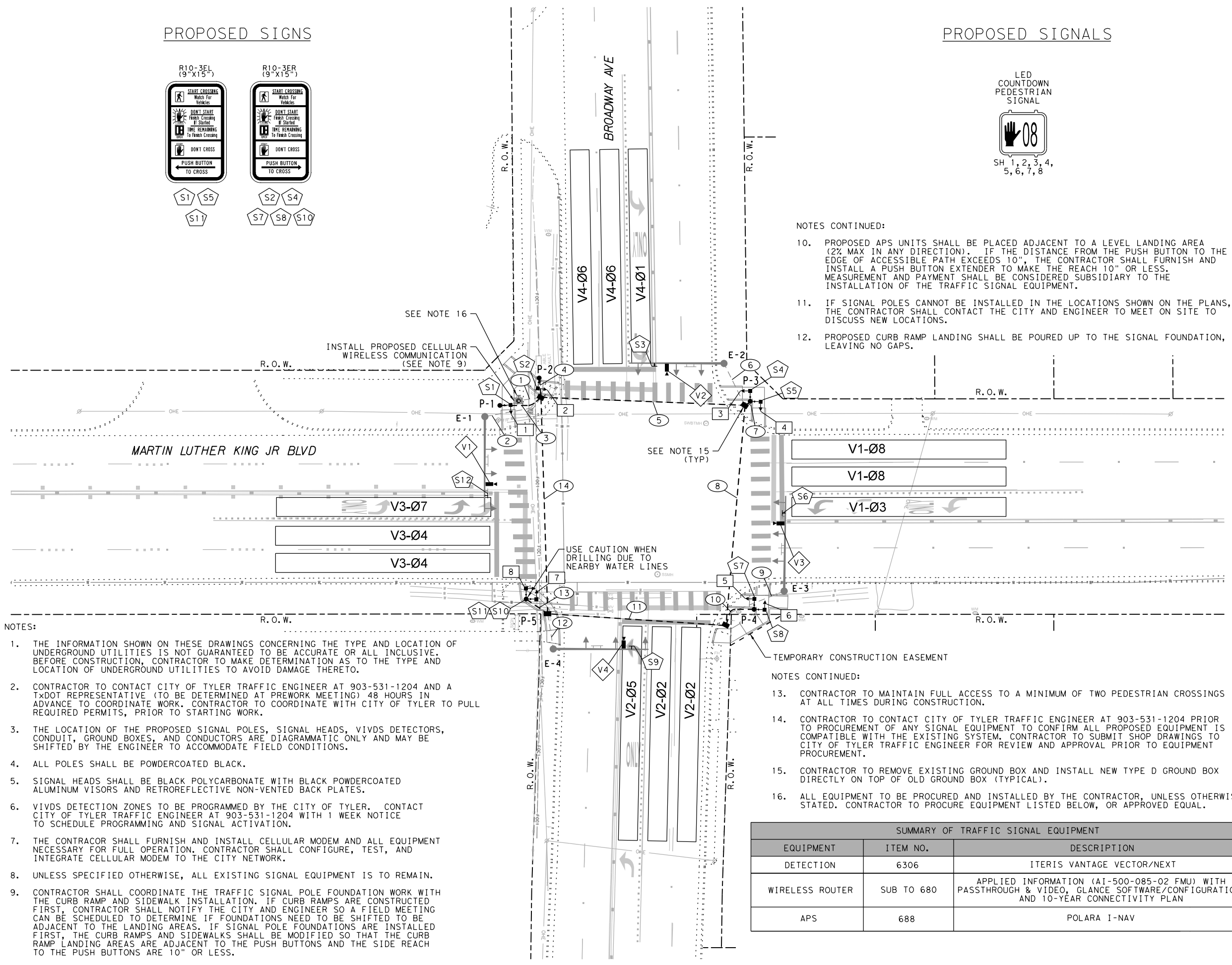

NOTES:

1. THE INFORMATION SHOWN ON THESE DRAWINGS CONCERNING THE TYPE AND LOCATION OF UNDERGROUND UTILITIES IS NOT GUARANTEED TO BE ACCURATE OR ALL INCLUSIVE. BEFORE CONSTRUCTION, CONTRACTOR TO MAKE DETERMINATION AS TO THE TYPE AND LOCATION OF UNDERGROUND UTILITIES TO AVOID DAMAGE THERETO.
2. CONTRACTOR TO CONTACT CITY OF TYLER TRAFFIC ENGINEER AT 903-531-1204 AND A TxDOT REPRESENTATIVE (TO BE DETERMINED AT PREWORK MEETING) 48 HOURS IN ADVANCE TO COORDINATE WORK. CONTRACTOR TO COORDINATE WITH CITY OF TYLER TO PULL REQUIRED PERMITS, PRIOR TO STARTING WORK.
3. THE LOCATION OF THE PROPOSED SIGNAL POLES, SIGNAL HEADS, VIVDS DETECTORS, CONDUIT, GROUND BOXES, AND CONDUCTORS ARE DIAGRAMMATIC ONLY AND MAY BE SHIFTED BY THE ENGINEER TO ACCOMMODATE FIELD CONDITIONS.
4. ALL POLES SHALL BE POWDERCOATED BLACK.
5. SIGNAL HEADS SHALL BE BLACK POLYCARBONATE WITH BLACK POWDERCOATED ALUMINUM VISORS AND RETROREFLECTIVE NON-VENTED BACK PLATES.
6. VIVDS DETECTION ZONES TO BE PROGRAMMED BY THE CITY OF TYLER. CONTACT CITY OF TYLER TRAFFIC ENGINEER AT 903-531-1204 WITH 1 WEEK NOTICE TO SCHEDULE PROGRAMMING AND SIGNAL ACTIVATION.
7. THE CONTRACTOR SHALL FURNISH AND INSTALL CELLULAR MODEM AND ALL EQUIPMENT NECESSARY FOR FULL OPERATION. CONTRACTOR SHALL CONFIGURE, TEST, AND INTEGRATE CELLULAR MODEM TO THE CITY NETWORK.
8. UNLESS SPECIFIED OTHERWISE, ALL EXISTING SIGNAL EQUIPMENT IS TO REMAIN.
9. CONTRACTOR SHALL COORDINATE THE TRAFFIC SIGNAL POLE FOUNDATION WORK WITH THE CURB RAMP AND SIDEWALK INSTALLATION. IF CURB RAMP ARE CONSTRUCTED FIRST, CONTRACTOR SHALL NOTIFY THE CITY AND ENGINEER SO A FIELD MEETING CAN BE SCHEDULED TO DETERMINE IF FOUNDATIONS NEED TO BE SHIFTED TO BE ADJACENT TO THE LANDING AREAS. IF SIGNAL POLE FOUNDATIONS ARE INSTALLED FIRST, THE CURB RAMP AND SIDEWALKS SHALL BE MODIFIED SO THAT THE CURB RAMP LANDING AREAS ARE ADJACENT TO THE PUSH BUTTONS AND THE SIDE REACH TO THE PUSH BUTTONS ARE 10" OR LESS.

PLOTTED: 5/13/2022 4:00:00 ft / in. BY: Marjanna Borrero
 FILENAME: K:\DAL_TPTO\project\063615008 - Tyler_HSP_P&E\CADD\TYL-HSIP_T1_022_MLK at Broadway_Pr-proposed.dgn

5/13/2022

Kimley»Horn F-928
 13455 Noel Road Two Galleria Office Tower, Suite 700 Dallas, Texas 75240 Tel. No. (972) 770-1300 Fax No. (972) 239-3820

Texas Department of Transportation © 2022

TRAFFIC SAFETY IMPROVEMENTS
 PROPOSED CONDITIONS

W. MLK JR. BOULEVARD
 AT BROADWAY AVENUE

DESIGN HMF	FED. RD. DIV. NO. 6	FEDERAL AID PROJECT NO. (SEE TITLE SHEET)	HIGHWAY NO. CS
GRAPHICS MB	STATE	DISTRICT TYLER	COUNTY COUNTY
CHECK ASA	TEXAS	SECTION SMITH	JOB
CHECK HMF	CONTROL	SECTION	JOB
	0910	16	165

28

PLOTTED: 5/13/2022 40.0000 ft / in. BY: Marjanna Borrero
 FILENAME: K:\DAL_TPTO\project\063615008 - Tyler HSIP PS&E\CADD\TYL-HSIP_T1_023_MLK at Broadway_Quantity 1 of 2.dgn

CONDUIT AND CABLE CHART																						
WIRE SIZE AND TYPE																						
RUN NO	CONDUIT STATUS	ITEM 618 CONDUIT (SCH 80)								CABLE STATUS	ITEM 620 ELECTRICAL CONDUCTORS				ITEM 684 TRAFFIC SIGNAL CABLES				ITEM 6306		TOTAL LENGTH OF RUN	RUN NO
		2" PVC (TRENCHED)		3" PVC (TRENCHED)		4" PVC (TRENCHED)		4" PVC (BORED)			NO. 6 BARE WIRE	TY C 2 CNDR NO. 12		TY A 5 CNDR NO. 14		TY A 10 CNDR NO. 14		VIVDS COMM. CABLE				
		Qty	Len	Qty	Len	Qty	Len	Qty	Len			Qty	Len	Qty	Len	Qty	Len	Qty	Len			
1	E	1	10						I													
	E					1	10		I			8	80					4	40			
	E					1	10		I					5	50							
2	E			1	30				I									1	30			
3	I	1	20						I	1	20			1	20							
4	I	1	10						I	1	10			1	10							
5	I							1	90					2	180			2	180			
6	E			1	20				I									1	20			
7	I	1	5						I	1	5			2	10			1	5			
8	I							1	95					2	190			1	95			
9	E			1	35				I									1	35			
10	I	1	20						I	1	20			2	40			1	20			
11	I							1	80													
12	E			1	20				I									1	20			
13	I	1	15						I	1	15			2	30			1	15			
14	I							1	95					2	190			1	95			
SUBTOTAL			70		0		0		360				430		930		0	490	515			
E-1	P								I									50	VARIES			
E-2	P								I									45	VARIES			
E-3	P								I									50	VARIES			
E-4	P								I									50	VARIES			
P-1	P								I				5	10					VARIES			
P-2	P								I				5	10					VARIES			
P-3	P								I				10	20					VARIES			
P-4	P								I				10	20					VARIES			
P-5	P								I				10	20					VARIES			
SUBTOTAL			0		0		0		0				0	40		80		0	195			
TOTAL			70		0		0		360				430		970		80		490	710		

CONDUIT STATUS: I=INSTALL; E=EXISTING; P=WIRE TO BE INSTALLED INSIDE STEEL POLE; A=ABANDON; REM=REMOVE AND SALVAGE
 E/P-# - REFERS TO WIRING WITHIN THE SIGNAL POLE AND MAST ARM.

SIGNAL HEAD AND POLE PLACEMENT (FT)											
POLE NUMBER	STATUS	A (FT)	B (FT)	C (FT)	D (FT)	F (FT)	G (FT)	ITEM 6306	DRILLED SHAFT	FDN. TYPE WIND ZONE 80 MPH	
								VIVDS DETECTOR (EA)	24" DIA SUB TO ITEM 687		
P-1	I	10								24-A	
P-2	I	8								24-A	
P-3	I	9								24-A	
P-4	I	10								24-A	
P-5	I	6								24-A	
E-1	E									-	
E-2	E									-	
E-3	E									-	
E-4	E									-	
TOTAL:								4	30		

SIGNAL POLE STATUS: I=INSTALL; E=EXISTING; REM=REMOVE; F=INSTALL IN FUTURE PHASE
 *- DOES NOT INCLUDE VERTICAL SIDEMOUNT SIGNAL HEADS OR PEDESTRIAN SIGNAL HEADS

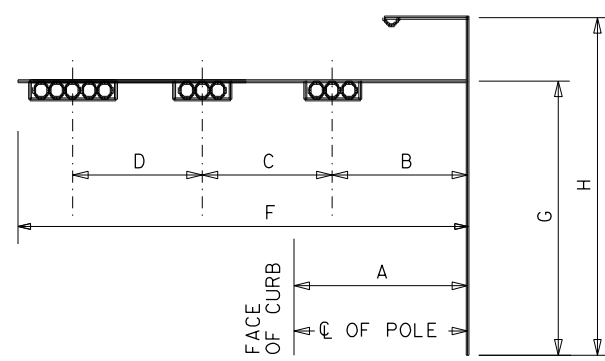

SIGNAL HEADS (ITEM 682)				
SIGNAL HEAD NUMBER	12" LED SIGNAL INDICATION		PED SIG SEC (LED) (COUNTDOWN)	EA
	SIGNAL HEAD TYPE	STATUS		
1	PED	I	1	
2	PED	I	1	
3	PED	I	1	
4	PED	I	1	
5	PED	I	1	
6	PED	I	1	
7	PED	I	1	
8	PED	I	1	
TOTAL (NEW)			8	

STATUS: I=INSTALL; E=EXISTING; REM=EXISTING TO BE REMOVED; REL=RELOCATE

GROUND BOX SUMMARY			
ITEM NO.	DESCRIPTION	UNIT	QTY.
0624	GROUND BOX TY D (162922)W/APRON	EA	4

APS MESSAGE CHART			
POLE LOCATION	PEDESTRIAN MOVEMENT	FUNCTIONS	SPEECH MESSAGE/SOUND DETAILS
P-1	Phase 6	BUTTON PUSH ON DW	WAIT.
		EXTENDED BUTTON PUSH	WAIT TO CROSS MARTIN LUTHER KING JUNIOR BOULEVARD AT BROADWAY AVENUE
		LOCATOR TONE	SLOW TICK
P-2	Phase 8	WALK INDICATION	RAPID TICK
		BUTTON PUSH ON DW	WAIT.
		EXTENDED BUTTON PUSH	WAIT TO CROSS BROADWAY AVENUE AT MARTIN LUTHER KING JUNIOR BOULEVARD
P-3	Phase 2	LOCATOR TONE	SLOW TICK
		WALK INDICATION	MARTIN LUTHER KING JUNIOR BOULEVARD, WALK SIGN IS ON TO CROSS MARTIN LUTHER KING JUNIOR BOULEVARD
		BUTTON PUSH ON DW	WAIT TO CROSS BROADWAY AVENUE AT MARTIN LUTHER KING JUNIOR BOULEVARD
P-3	Phase 8	EXTENDED BUTTON PUSH	WAIT TO CROSS BROADWAY AVENUE AT MARTIN LUTHER KING JUNIOR BOULEVARD
		LOCATOR TONE	SLOW TICK
		WALK INDICATION	BROADWAY AVENUE, WALK SIGN IS ON TO CROSS BROADWAY AVENUE
P-4	Phase 2	BUTTON PUSH ON DW	WAIT TO CROSS MARTIN LUTHER KING JUNIOR BOULEVARD AT BROADWAY AVENUE
		EXTENDED BUTTON PUSH	WAIT TO CROSS MARTIN LUTHER KING JUNIOR BOULEVARD AT BROADWAY AVENUE
		LOCATOR TONE	SLOW TICK
P-4	Phase 4	WALK INDICATION	MARTIN LUTHER KING JUNIOR BOULEVARD, WALK SIGN IS ON TO CROSS MARTIN LUTHER KING JUNIOR BOULEVARD
		BUTTON PUSH ON DW	WAIT TO CROSS BROADWAY AVENUE AT MARTIN LUTHER KING JUNIOR BOULEVARD
		EXTENDED BUTTON PUSH	WAIT TO CROSS BROADWAY AVENUE AT MARTIN LUTHER KING JUNIOR BOULEVARD
P-4	Phase 2	LOCATOR TONE	SLOW TICK
		WALK INDICATION	BROADWAY AVENUE, WALK SIGN IS ON TO CROSS BROADWAY AVENUE
		BUTTON PUSH ON DW	WAIT TO CROSS MARTIN LUTHER KING JUNIOR BOULEVARD AT BROADWAY AVENUE
P-5	Phase 6	EXTENDED BUTTON PUSH	WAIT TO CROSS MARTIN LUTHER KING JUNIOR BOULEVARD AT BROADWAY AVENUE
		LOCATOR TONE	SLOW TICK
		WALK INDICATION	MARTIN LUTHER KING JUNIOR BOULEVARD, WALK SIGN IS ON TO CROSS MARTIN LUTHER KING JUNIOR BOULEVARD
P-5	Phase 4	BUTTON PUSH ON DW	WAIT TO CROSS BROADWAY AVENUE AT MARTIN LUTHER KING JUNIOR BOULEVARD
		EXTENDED BUTTON PUSH	WAIT TO CROSS BROADWAY AVENUE AT MARTIN LUTHER KING JUNIOR BOULEVARD
		LOCATOR TONE	SLOW TICK
		WALK INDICATION	BROADWAY AVENUE, WALK SIGN IS ON TO CROSS BROADWAY AVENUE

* COUNTDOWN SPEECH MESSAGE = "OFF" FOR ALL UNITS

5/13/2022

13455 Noel Road
Two Galleria Office Tower, Suite 700
Dallas, Texas 75240

Tel. No. (972) 770-1300
Fax No. (972) 239-3820

© 2022

TRAFFIC SAFETY IMPROVEMENTS
PROPOSED QUANTITIES

W. MLK JR. BOULEVARD
AT BROADWAY AVENUE

SHEET 1 OF 2

DESIGN HMF	FED. RD. DIV. NO. 6	FEDERAL AID PROJECT NO. (SEE TITLE SHEET)	HIGHWAY NO. CS
GRAPHICS MB	STATE	DISTRICT	COUNTY
CHECK ASA	TEXAS	TYLER	SMITH
CHECK HMF	CONTROL	SECTION	JOB
	0910	16	165

29

CABLE TERMINATION CHART						
CNR. NO.	CONDUCTOR COLOR	CABLE 1 10 CNDR.	CABLE 2 10 CNDR.	CABLE 3 10 CNDR.	CABLE 4 10 CNDR.	CABLE 5 10 CNDR.
		FROM P-1 TO CNTRL.	FROM P-2 TO CNTRL.	FROM P-3 TO CNTRL.	FROM P-4 TO CNTRL.	FROM P-5 TO CNTRL.
1	BLACK	SPARE	SPARE	SPARE	SPARE	SPARE
2	WHITE	SH COM	SH COM	SH COM	SH COM	SH COM
3	RED	SPARE	SPARE	SPARE	SPARE	SPARE
4	GREEN	SPARE	SPARE	SPARE	SPARE	SPARE
5	ORANGE	SPARE	SPARE	SPARE	SPARE	SPARE
6	BLUE	SH 1 - Ø6 DW	SH 2 - Ø8 DW	SH 3 - Ø8 DW	SH 5 - Ø4 DW	SH 7 - Ø6 DW
7	WHITE/BLACK	SH 1 - Ø6 W	SH 2 - Ø8 W	SH 3 - Ø8 W	SH 5 - Ø4 W	SH 7 - Ø6 W
8	RED/BLACK	SPARE	SPARE	SPARE	SPARE	SPARE
9	GREEN/BLACK	SPARE	SPARE	SH 4 - Ø2 DW	SH 6 - Ø2 DW	SH 8 - Ø4 DW
10	ORANGE/BLACK	SPARE	SPARE	SH 4 - Ø2 W	SH 6 - Ø2 W	SH 8 - Ø4 W

*NOTE: HOME RUN 2 CONDR. TO ALL POLES WITH PED HEADS FOR PED CALL

VIVDS DETECTION ZONE DETAILS				
DETECTOR NUMBER	MOUNTING LOCATION	MOUNTING HEIGHT	ZONE (S)	DESCRIPTION
V1	SIGNAL POLE E-1	25'	WB + WBLT	ADVANCED + PRESENCE
V2	SIGNAL POLE E-2	25'	NB + NBLT	ADVANCED + PRESENCE
V3	SIGNAL POLE E-3	25'	EB + EBLT	ADVANCED + PRESENCE
V4	SIGNAL POLE E-4	25'	SB + SBLT	ADVANCED + PRESENCE

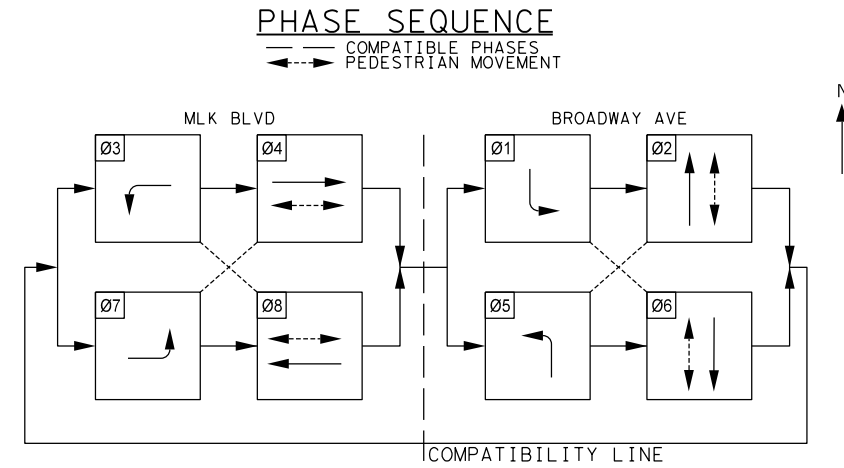

PLOTTED: 5/13/2022 4:00:00 PM BY: Marjanna Borrero
 FILENAME: K:\DAL_TPTO\project\063615008 - Tyler HSIP PS&E\CADD\TYL-HSIP_T1_024_MLK at Broadway_Quantity 2 of 2.dgn

5/13/2022

13455 Noel Road
Two Galleria Office Tower, Suite 700
Dallas, Texas 75240

Tel. No. (972) 770-1300
Fax No. (972) 239-3820

© 2022

**TRAFFIC SAFETY IMPROVEMENTS
PROPOSED QUANTITIES**

**W. MLK JR. BOULEVARD
AT BROADWAY AVENUE**

SHEET 2 OF 2

DESIGN	FED. RD. DIV. NO.	FEDERAL AID PROJECT NO.	HIGHWAY NO.
HMF	6	(SEE TITLE SHEET)	CS
GRAPHICS	STATE	DISTRICT	COUNTY
MB	TEXAS	TYLER	SMITH
CHECK	CONTROL	SECTION	JOB
ASA	0910	16	165
CHECK			
HMF			

NOTES:

1. INSTALLATION AND PAYMENT FOR PROPOSED RAMPS AND SIDEWALKS SHALL INCLUDE ALL INCIDENTAL WORK, INCLUDING EXCAVATION, REMOVAL AND DISPOSAL OF EXISTING CONCRETE CURB AND SIDEWALK, PROPOSED CURB ALONG SIDEWALKS, AND OTHER MISCELLANEOUS MATERIAL NECESSARY TO CONSTRUCT THE PROPOSED RAMPS AND SIDEWALKS. SIDEWALK QUANTITIES PROVIDED ARE ESTIMATES ONLY. PAYMENT FOR SIDEWALK SHALL BE FOR THE QUANTITY APPROVED BY THE ENGINEER AND CONSTRUCTED ON SITE.
2. PROPOSED CURB RAMP LANDING SHALL BE POURED UP TO THE SIGNAL FOUNDATION, LEAVING NO GAPS.
3. REFER TO THE TXDOT PM-20 STANDARDS FOR ADDITIONAL INFORMATION REGARDING TYPICAL PAVEMENT MARKING PLACEMENT.
4. LANE WIDTHS SHALL MATCH EXISTING LANES. ALL PROPOSED PAVEMENT MARKINGS SHALL BE TIED TO EXISTING MARKINGS WHERE APPLICABLE TO REFRESH THE INTERSECTION PAVEMENT MARKINGS.
5. ALL SIGNS TO BE FABRICATED AND INSTALLED BY CONTRACTOR. PROVIDE SHOP DRAWINGS TO CITY OF TYLER SIGNS DEPARTMENT AND OBTAIN APPROVAL PRIOR TO FABRICATION.
6. STRIPING CONTRACTOR SHALL CONTACT CITY OF TYLER TRAFFIC ENGINEER AND TXDOT TRAFFIC SIGNAL OFFICE AT LEAST 24 HOURS IN ADVANCE OF MOBILIZATION. CITY OF TYLER STAFF MUST BE PRESENT TO CONFIRM LAYOUT PRIOR TO THE APPLICATION OF ANY PAVEMENT MARKINGS.
7. CONTRACTOR IS RESPONSIBLE FOR REPAIRS AND SUBSTITUTION OF ANY DAMAGED IRRIGATION EQUIPMENT.
8. INSTALL PAVEMENT MARKINGS 200' IN EACH DIRECTION FROM STOP BAR.
9. CONTRACTOR SHALL ENSURE THAT ALL PED RAMPS DRAIN TOWARDS THE STREET WITHOUT PONDING IN THE RAMP OR GUTTER AREA.
10. RAMP LANDINGS AND PROPOSED SIDEWALKS SHALL NOT EXCEED 2% MAX CROSS SLOPE AND 2% RUNNING SLOPE.
11. ALL PAVEMENT MARKINGS ON THE WEST APPROACH FROM STOP BAR 200' WEST WILL BE INSTALLED AS PART OF A CITY OF TYLER ROADWAY OVERLAY PROJECT.



LEGEND
PEDESTRIAN RAMPS

- [Hatched Pattern] 8.3% MAX RUNNING SLOPE
2% MAX CROSS SLOPE
- [Hatched Pattern] 5% MAX RUNNING SLOPE
2% MAX CROSS SLOPE

LEGEND
PAVEMENT MARKING

- (A) RE PM W/RET REQ TY I (W) 4" (BRK) (100MIL)
- (B) RE PM W/RET REQ TY I (W) 4" (SLD) (100MIL)
- (C) REFL PAV MRK TY I (W) 8" (SLD) (100MIL)
- (D) REFL PAV MRK TY I (W) 12" (SLD) (100MIL)
- (E) REFL PAV MRK TY I (W) 24" (SLD) (100MIL)
- (F) PREFAB PAV MRK TY C (W) (ARROW)
- (G) PREFAB PAV MRK TY C (W) (WORD)
- (H) RE PM W/RET REQ TY I (Y) 4" (SLD) (100MIL)
- (I) REFL PAV MRK TY I (Y) 24" (SLD) (100MIL)
- (J) REFL PAV MRK TY II A-A
- (K) REFL PAV MRK TY I-C
- (L) REFL PAV MRK TY I (W) 4" (DOT) (100MIL)
- (M) REFL PAV MRK TY I (W) 18" (YLD TRI) (<40mph)
- (N) RE PM W/RET REQ TY I (W) 6" (SLD) (100MIL)

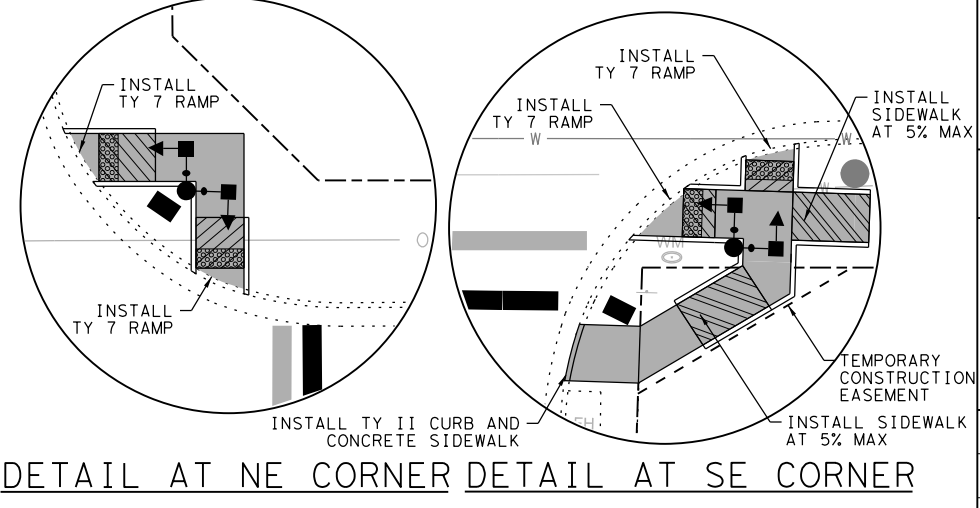
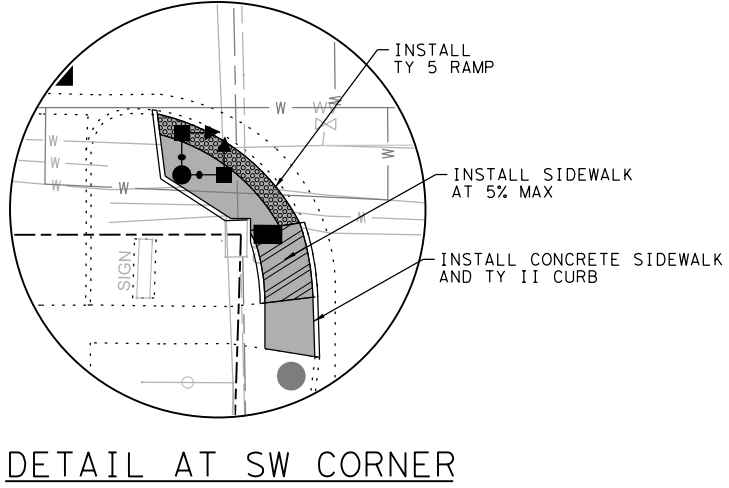
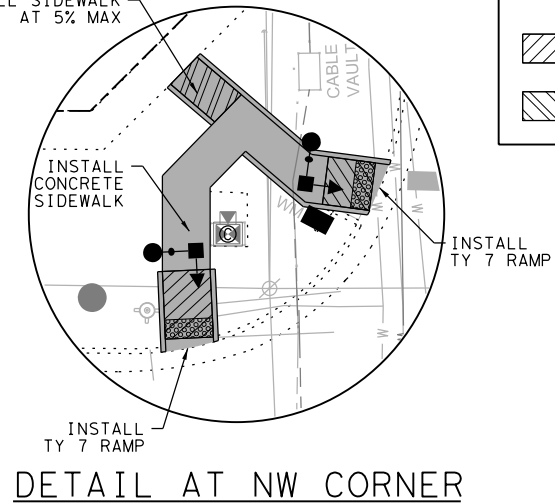
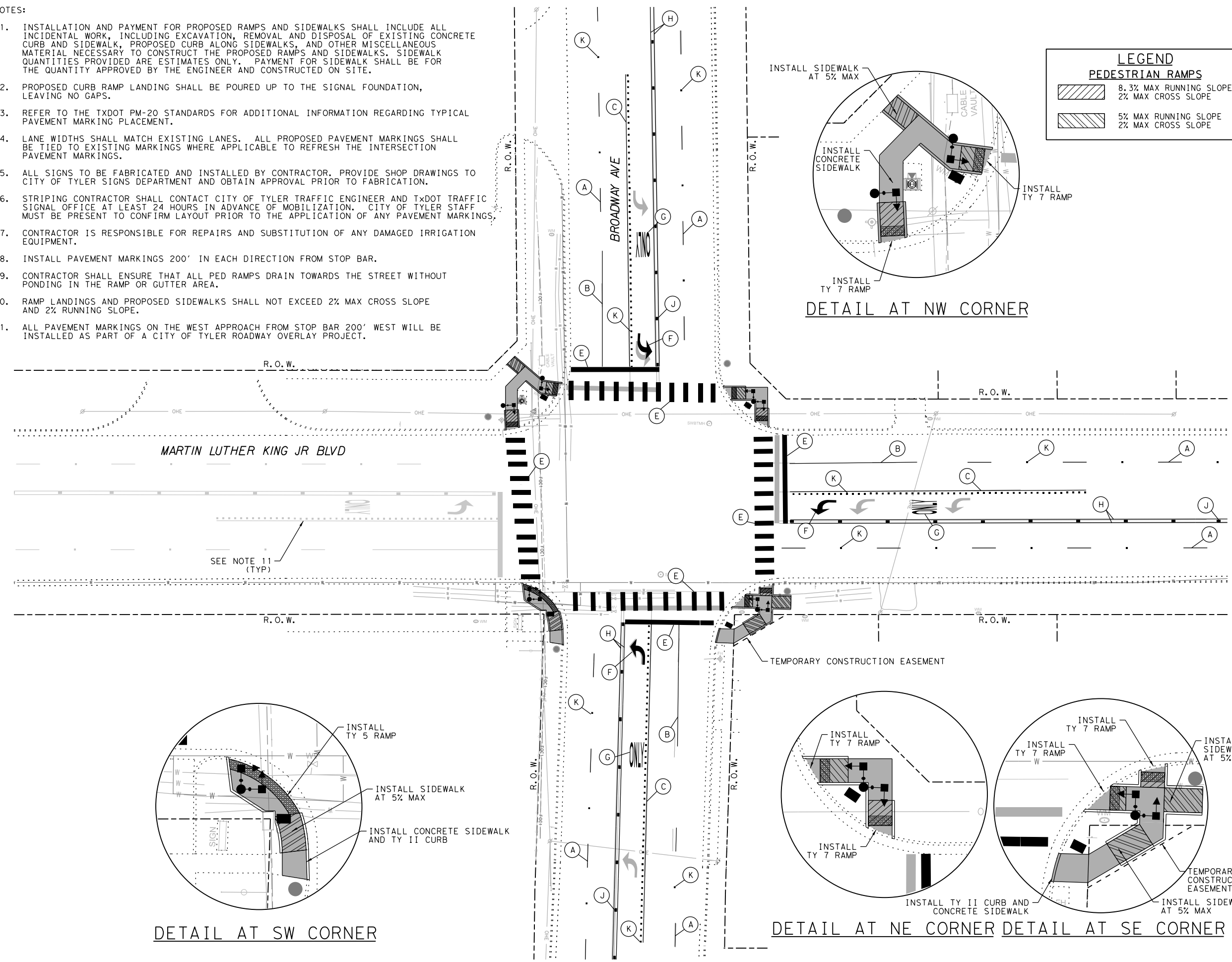

5/25/2022



Kimley»Horn

13455 Noel Road
Two Galleria Office Tower, Suite 700
Dallas, Texas 75240 Tel. No. (972) 770-1300
Fax No. (972) 239-3820



Texas Department of Transportation
© 2022

TRAFFIC SAFETY IMPROVEMENTS
PROPOSED PAVEMENT MARKINGS
AND PEDESTRIAN RAMPS
W. MLK JR. BOULEVARD
AT BROADWAY AVENUE

DESIGN	FED. RD. DIV. NO.	FEDERAL AID PROJECT NO.	HIGHWAY NO.
HMF	6	(SEE TITLE SHEET)	CS
GRAPHICS	STATE	DISTRICT	COUNTY
MB	TEXAS	TYLER	SMITH
CHECK	CONTROL	SECTION	JOB
ASA			
CHECK			
HMF	0910	16	165

PLOTTED: 5/25/2022 4:00:00 ft / in. BY: Marianna Borrero
 FILENAME: K:\DAL_TPT\1project\063615008 - Tyler_HSP_PS&E\CADD\TYL-HS_IP_T1_026_MLK of Broadway_Striping.dgn

K:\DAL\TPTO\Project\063615008 - Tyler_HSP_PS&E\CADD\Standards\MLK_Corridor\Ped_Standard - TYL.dgn

5/25/2022

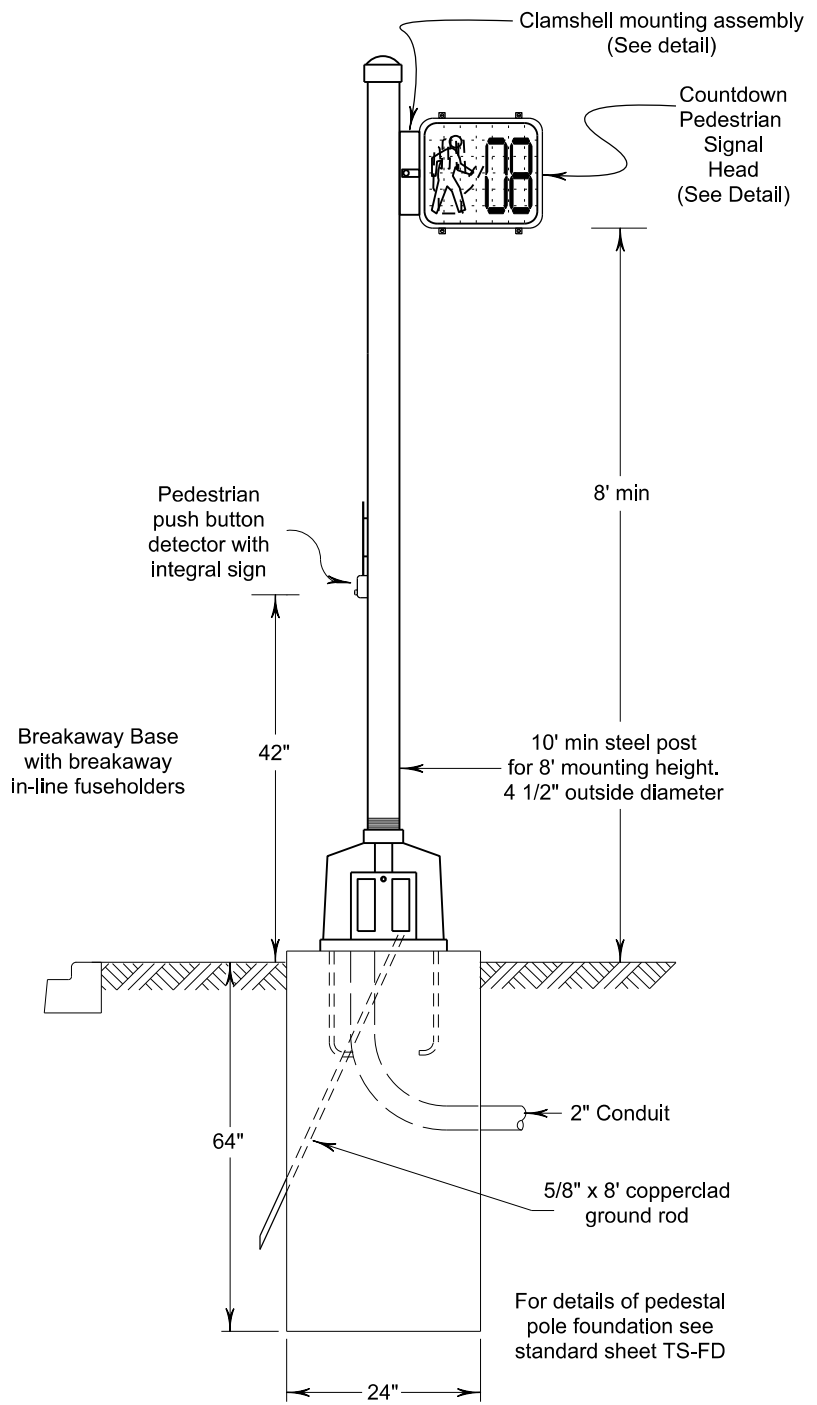

DETAIL OF PEDESTAL POLE WITH OPTIONAL CONCRETE FOUNDATION

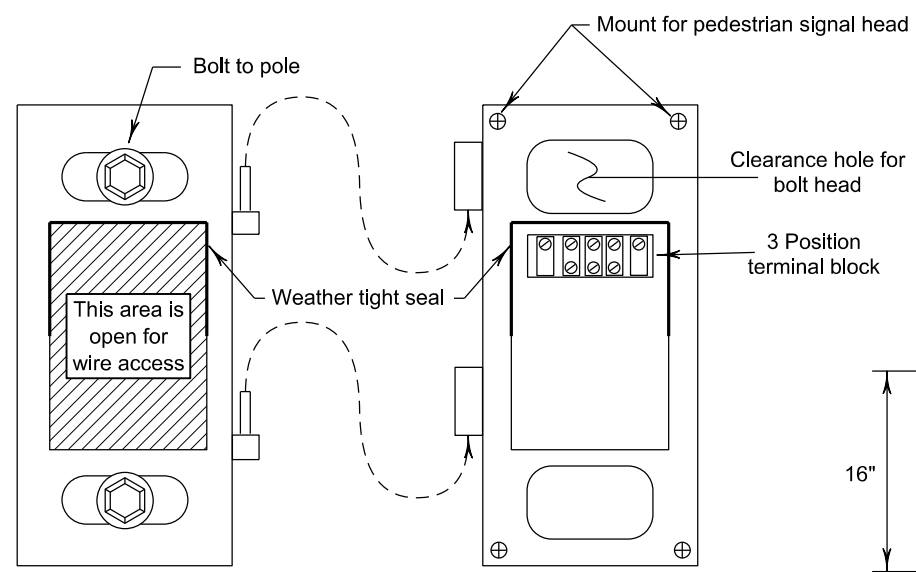

DETAIL OF CLAMSHELL TWO-PART MOUNTING ASSEMBLY WITH VANDAL-PROOF EXTERIOR LOCK

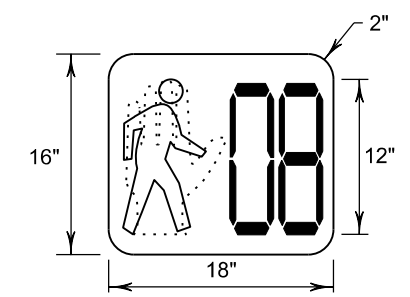

PEDESTRIAN COUNTDOWN SIGNAL HEAD DETAIL

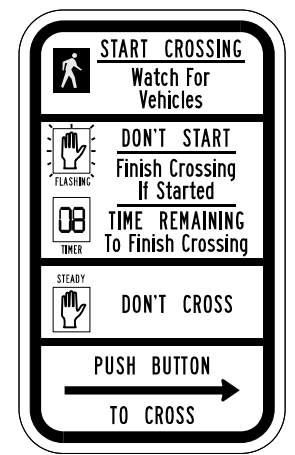

ACCESSIBLE PEDESTRIAN PUSH BUTTON DETECTOR WITH SIGN

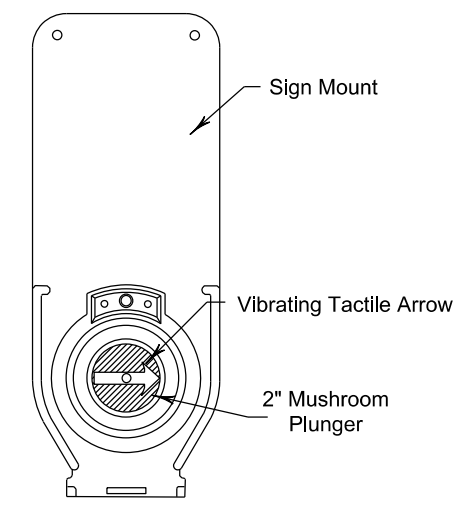

Audible Pedestrian Signal

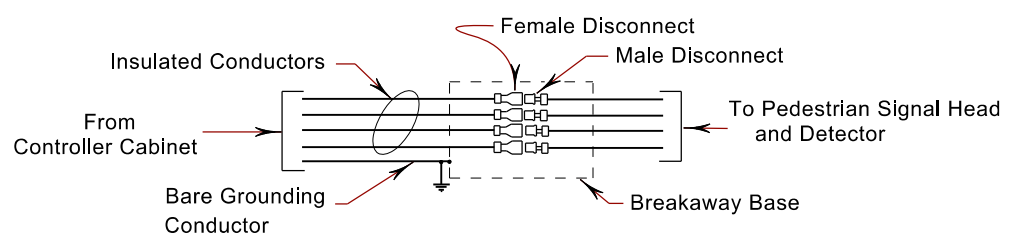

NON-FUSED BREAKAWAY ELECTRICAL CONNECTORS

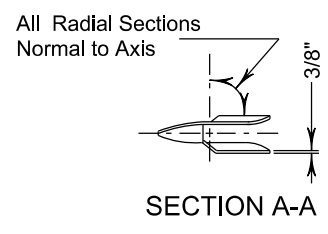

SECTION A-A

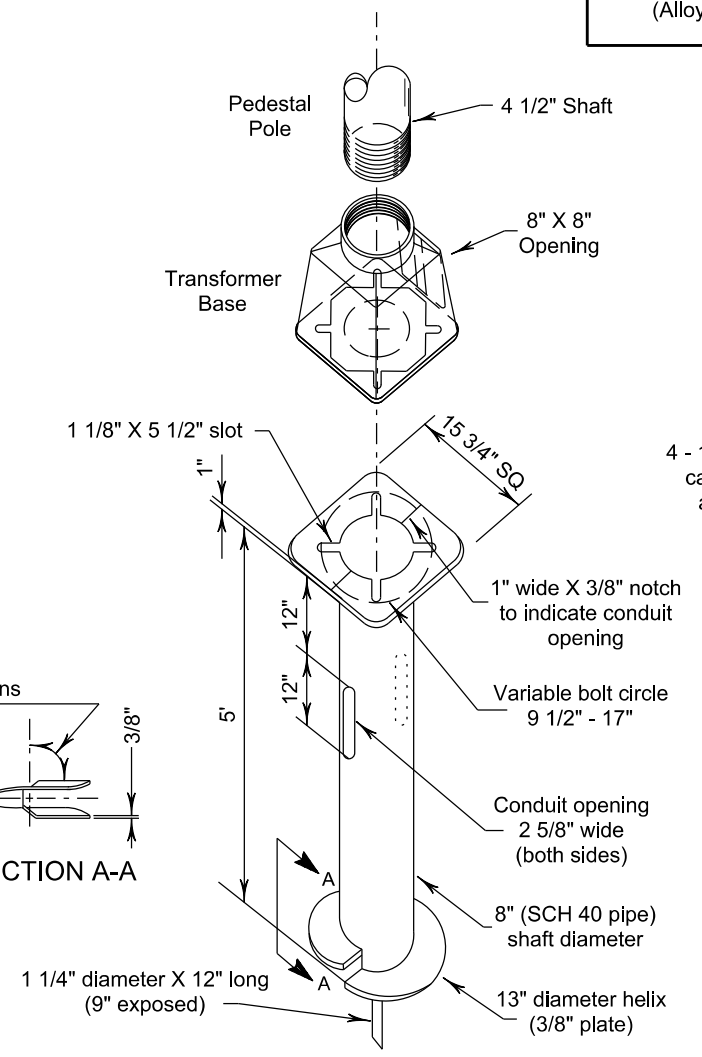

SCREW-IN ANCHOR FOUNDATION DETAIL

NOTES:

1. All pedestrian signal heads shall be installed on the away-from-traffic side of the pedestal pole or signal pole.
2. All wiring for pedestrian signals shall be completely enclosed within the signal mounting hardware.
3. All pedestrian signal heads and push button detectors shall display the symbolized message shown.
4. There shall be a continuous bare ground wire from all steel poles back to the electrical service.
5. All pedestrian signal heads shall be 12" LED with 2 indications per signal head, unless otherwise shown in the plans.
6. Use either a Screw-In Type Anchor Foundation or 24" Drill Shaft Foundation as shown elsewhere in the plans.
7. See Special Specification 4004, "Screw-In Type Anchor Foundations" for further requirements.
8. Engage all thread on the pedestal pole base and pipe, according to manufacturers recommendation, unless pipe is fully seated into base.
9. Conduit in foundation and within 6" of foundation is subsidiary to Item 687, "Pedestal Pole Assemblies."
10. Provide non-fused watertight breakaway electrical connectors for breakaway poles. (Bussmann HET, Littelfuse LET, Ferraz-Shawmut FEBN, or approved equal).
11. For both pedestal pole and signal pole mounts, provide clearance as shown above the sidewalk level.
12. Make connections to ground rods according to the NEC. Ground rod clamps shall be listed for their intended purpose.
13. Provide pedestal pole base in accordance with Departmental Material Specifications.
14. Unless otherwise shown on the plans, pole shaft shall be one piece, SCH 40 aluminum pipe, ASTM B221 (Alloy 6061-T6) only. Aluminum conduit will not be permitted.

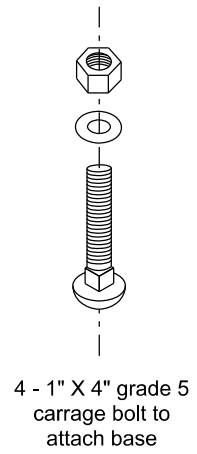

4 - 1" X 4" grade 5 carriage bolt to attach base



THE AFFIXED SEAL ABOVE APPLIES ONLY TO INFORMATION FILLED BY ABOVE STATED ENGINEER.



PEDESTRIAN SIGNAL AND DETECTOR INSTALLATION DETAILS

FED. RD. DIV. NO.	PROJECT NO.	SHEET NO.	
6	(SEE TITLE SHEET)	32	
STATE	DIST.	COUNTY	
TEXAS	TYLER	SMITH	
CONT.	SECT.	JOB	HIGHWAY NO.
0910	16	165	MLK JR

PLOTTED: 5/13/2022 40.0000 ft / in. BY: Maricanna Borrero
 FILENAME: K:\DAL_TPTO\project\063615008 - Tyler HSIP PS&E\CADD\Standards\MLK_Corr\1.dwg\TYL-HSIP_T1_127_Broadway at MLK_Sidewalk_Detail1.s.dwg

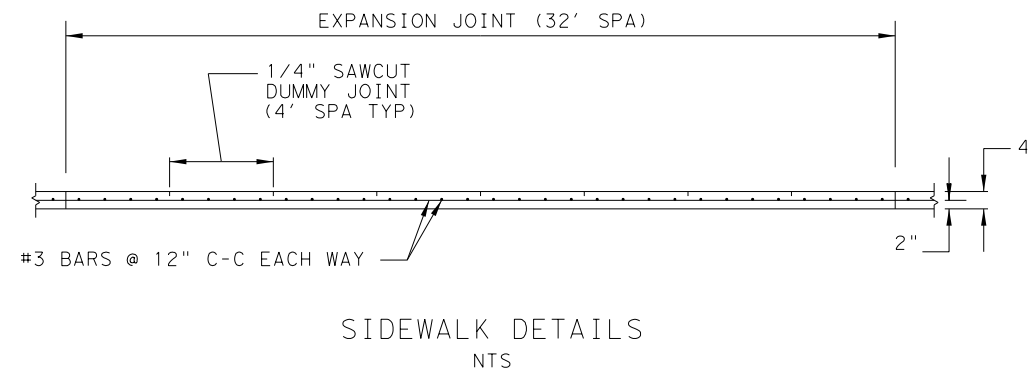
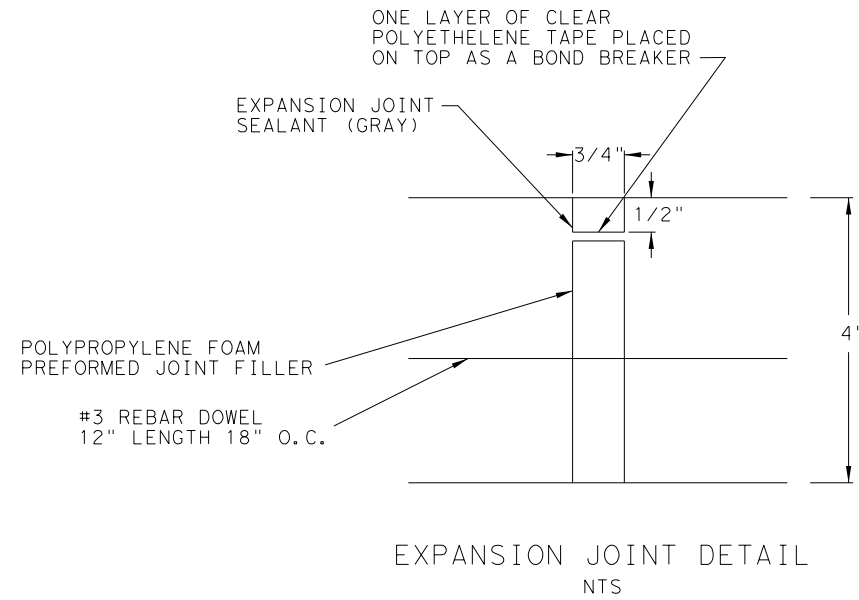

Kimley»Horn F-928

13455 Noel Road Two Galleria Office Tower, Suite 700 Dallas, Texas 75240 Tel. No. (972) 770-1300 Fax No. (972) 239-3820



Texas Department of Transportation © 2022

TRAFFIC SAFETY IMPROVEMENTS

SIDEWALK DETAILS

DESIGN	FED. RD. DIV. NO.	FEDERAL AID PROJECT NO.	HIGHWAY NO.
HMF	6	(SEE TITLE SHEET)	MLK JR
GRAPHICS	STATE	DISTRICT	COUNTY
MB	TEXAS	TYLER	SMITH
CHECK	CONTROL	SECTION	JOB
ASA			
CHECK	0910	16	165
HMF			

33

DISCLAIMER: The use of this standard is governed by the "Texas Engineering Practice Act". No warranty of any kind is made by TxDOT for any purpose whatsoever. TxDOT assumes no responsibility for the conversion of this standard to other formats or for incorrect results or damages resulting from its use.

DATE:
FILE:

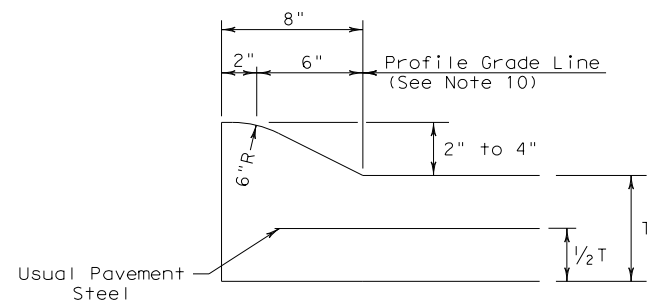

TYPE I CURB (MONOLITHIC)
2" - 4" HEIGHT

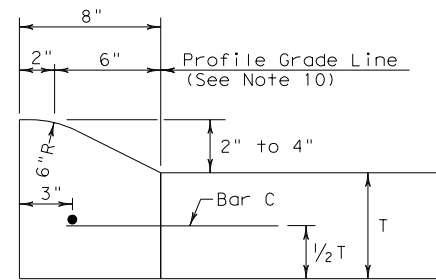

TYPE I CURB
2" - 4" HEIGHT

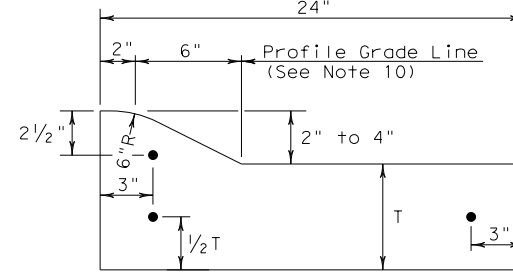

TYPE I CURB AND GUTTER
2" - 4" HEIGHT

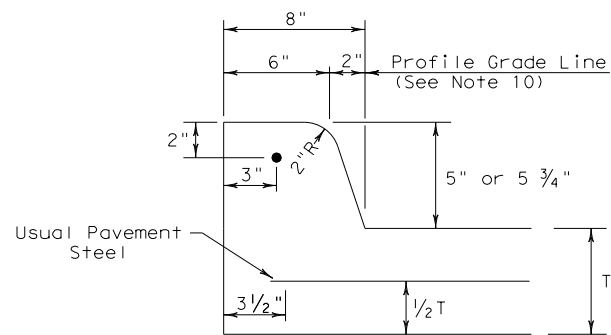

TYPE II CURB (MONOLITHIC)
5" - 5 3/4" HEIGHT

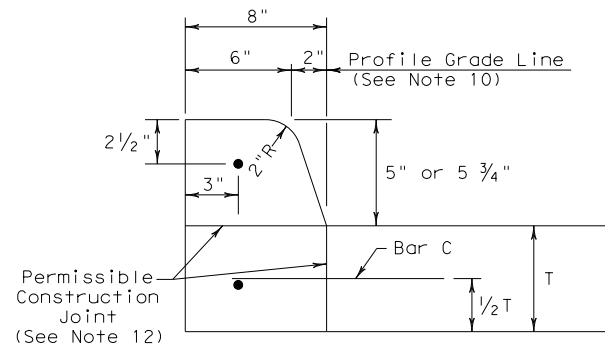

TYPE II CURB
5" - 5 3/4" HEIGHT

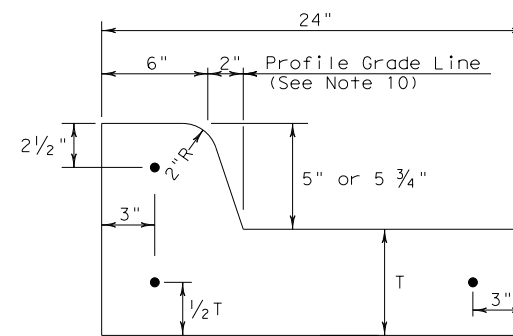

TYPE II CURB AND GUTTER
5" - 5 3/4" HEIGHT

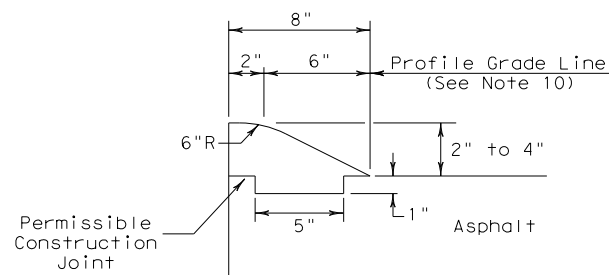

TYPE III CURB (KEYED)
2" - 4" HEIGHT

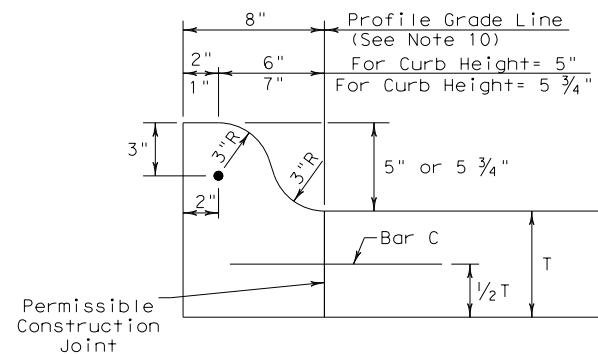

TYPE IIa CURB
5" - 5 3/4" HEIGHT

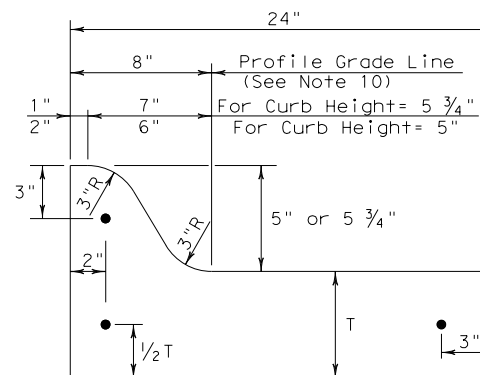

TYPE IIa CURB AND GUTTER
5" - 5 3/4" HEIGHT

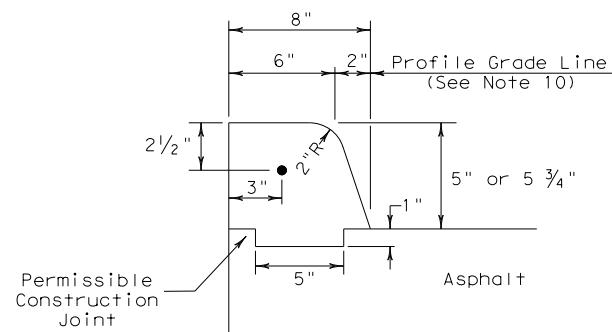

TYPE IV CURB (KEYED)
5" - 5 3/4" HEIGHT

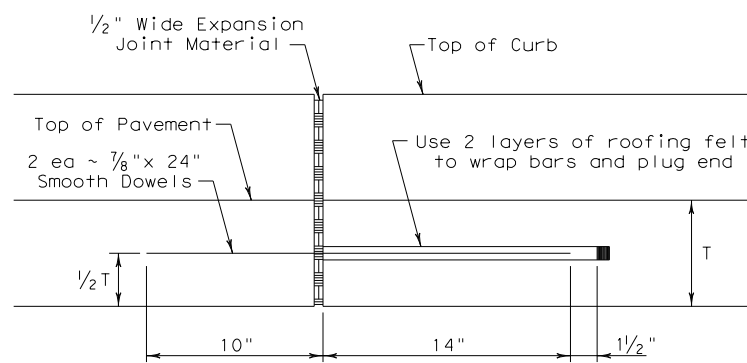

EXPANSION JOINT DETAIL

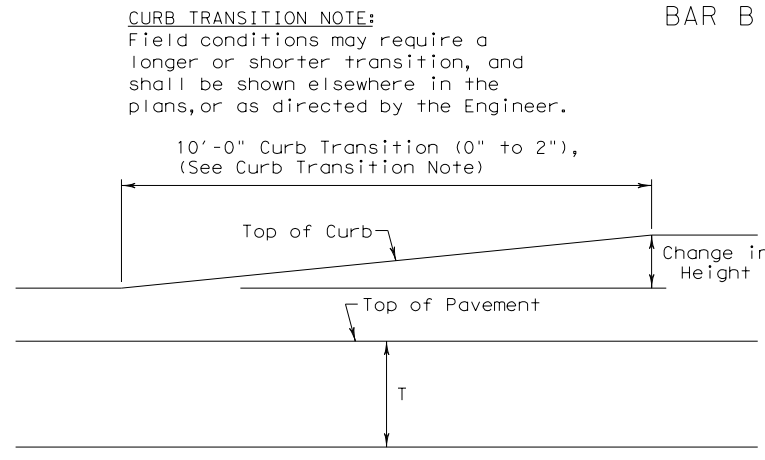

CURB TRANSITION
Note: To be paid for as Highest Curb

GENERAL NOTES

- All materials and construction shall be in accordance with Item 529, "Concrete Curb, Gutter, and Combined Curb and Gutter."
- Concrete shall be Class A.
- When reinforcing bars are used, they shall be No.4 unless otherwise shown. The use of fiber reinforced concrete in lieu of reinforcing steel is acceptable. Use fibers meeting the requirements of DMS 4550, "Fibers for Concrete," and dose fibers in accordance with Material Producers List (MPL) "Fibers for Class A and B Concrete Applications."
- Round exposed sharp edges with a rounding tool, to a minimum radius of 1/4 inch.
- All existing curbs and driveways to be removed shall be sawed or removed at existing joints.
- Where concrete curb is to be placed on existing concrete pavement, Bar B may be drilled and the grouted in place, or may be inserted into fresh concrete.
- Expansion and contraction joints shall be constructed to match pavement joints in all curbs and curb and gutter adjacent to jointed concrete pavement. Where placement of curb or curb and gutter is not adjacent to concrete pavement, expansion joints shall be provided at structures, curb returns at streets, and at locations directed by The Engineer.
- Vertical and horizontal dowel bars and transverse reinforcing bars shall be placed at four feet C-C.
- Dimension 'T' shown is the thickness of concrete pavement. When curb is installed adjacent to flexible pavement dimension 'T' is 8" maximum.
- Usual profile grade line. Refer to typical sections and plan-profile sheets for exact locations.
- One-half inch expansion joint material shall be provided where curb or curb and gutter is adjacent to sidewalk or riprap.
- When horizontal permissible construction joints are used, the longitudinal pavement steel shall be placed in accordance with pavement details shown elsewhere in the plans. Reinforcing steel for curb section shall then conform to that required for concrete curb.
- Bar B used as needed to support curb reinforcing steel during concrete placement.

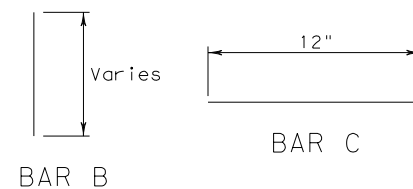

CURB TRANSITION NOTE:
Field conditions may require a longer or shorter transition, and shall be shown elsewhere in the plans, or as directed by the Engineer.

				Design Division Standard	
<p>CONCRETE CURB AND CURB AND GUTTER</p> <p>CCCG-21</p>					
FILE: cccg21.dgn	DN: TxDOT	CK: AN	DW: SS	CK: KM	
© TxDOT: FEBRUARY 2021	CONT	SECT	JOB	HIGHWAY	
REVISTONS	0910	16	165	MLK JR	
	DIST	COUNTY		SHEET NO.	
	TYLER	SMITH		34	

DISCLAIMER: The use of this standard is governed by the "Texas Engineering Practice Act". No warranty of any kind is made by TxDOT for any purpose whatsoever. TxDOT assumes no responsibility for the conversion of this standard to other formats or for incorrect results or damages resulting from its use.

DATE: FILE:

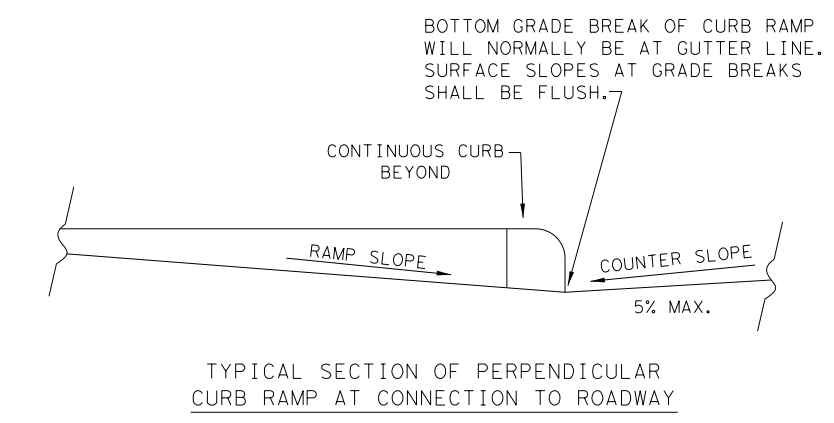
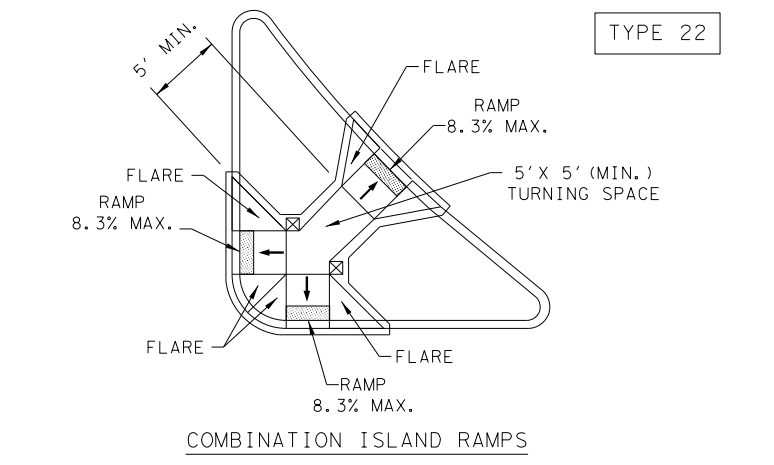
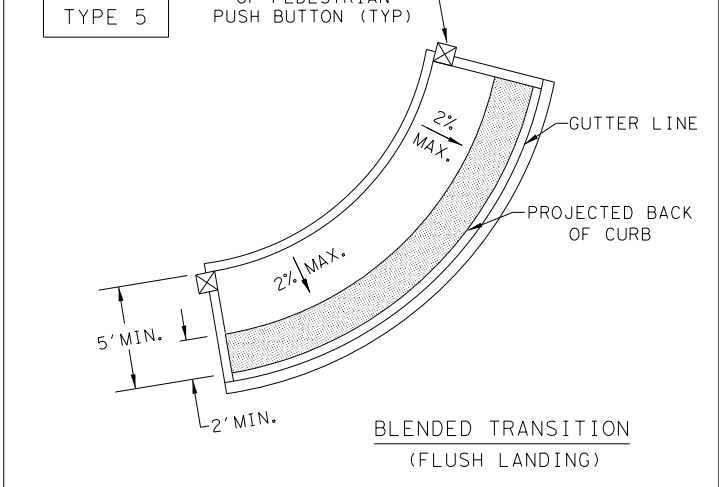
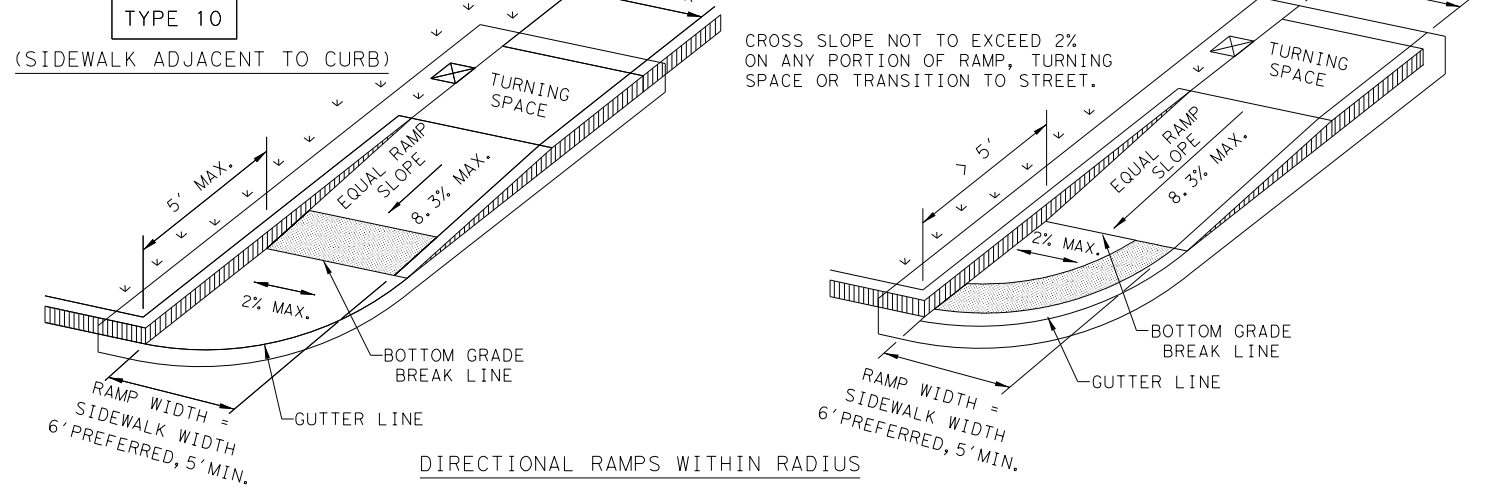
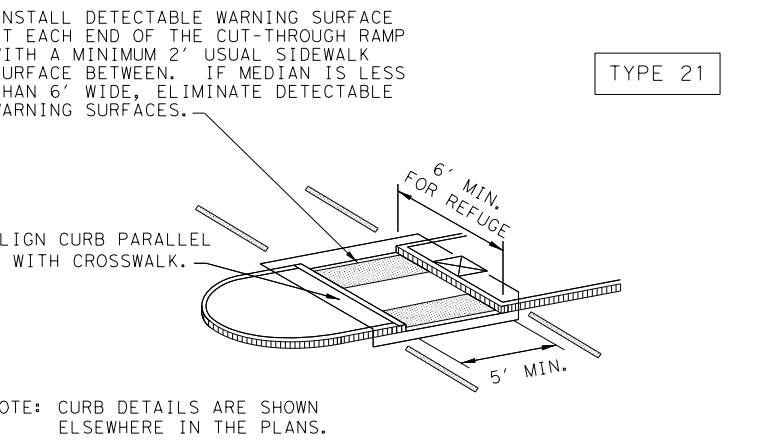
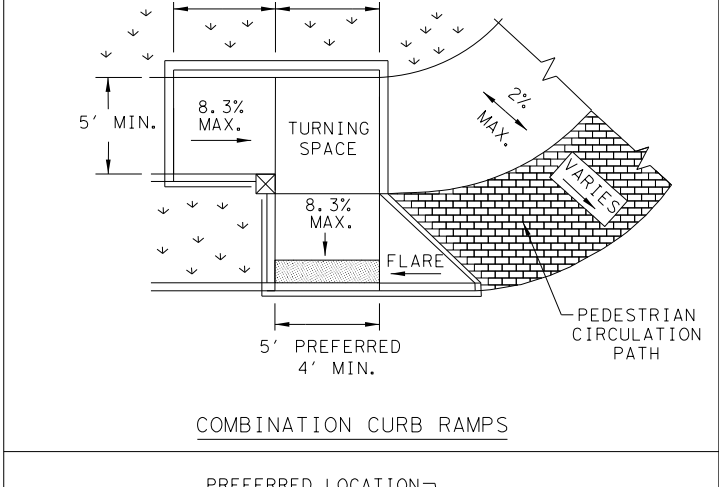
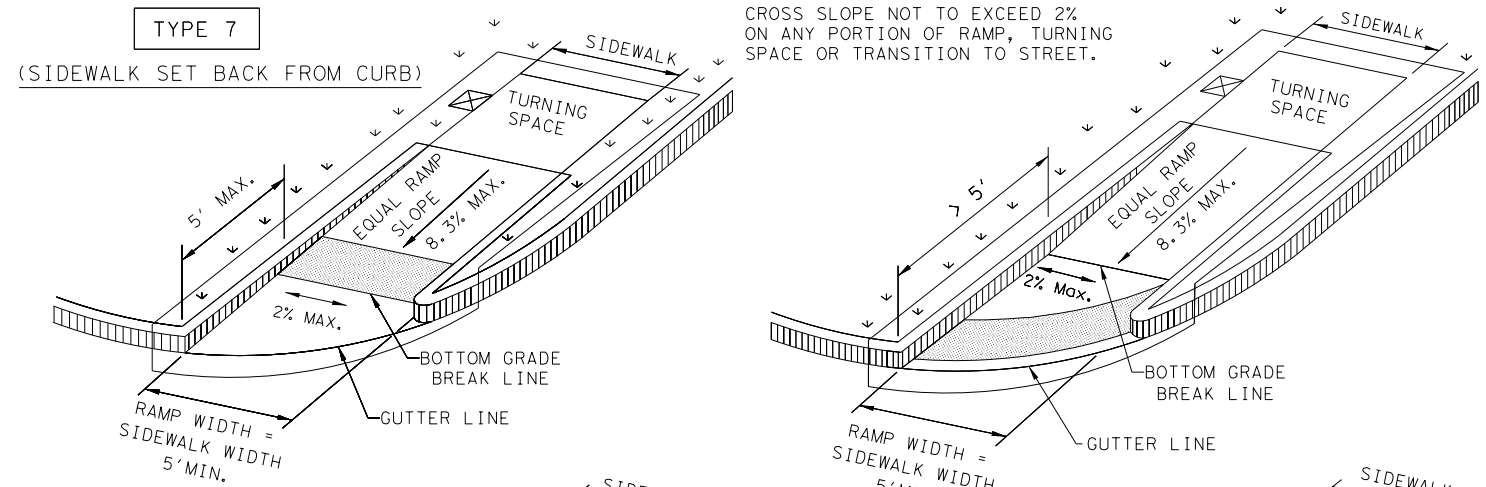
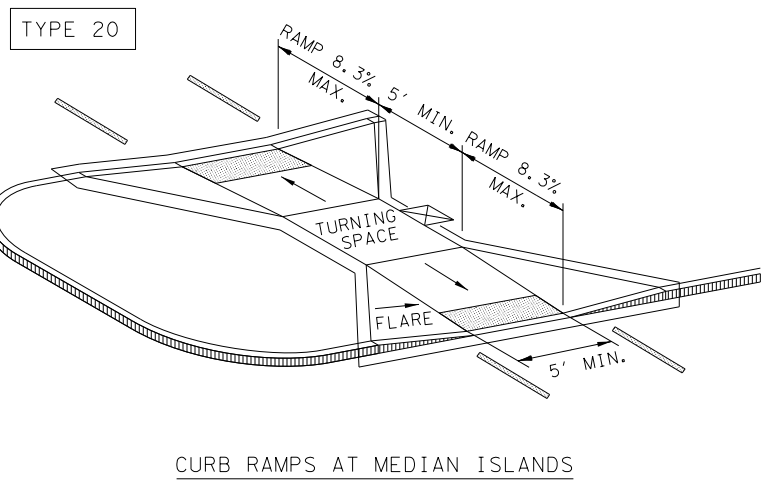
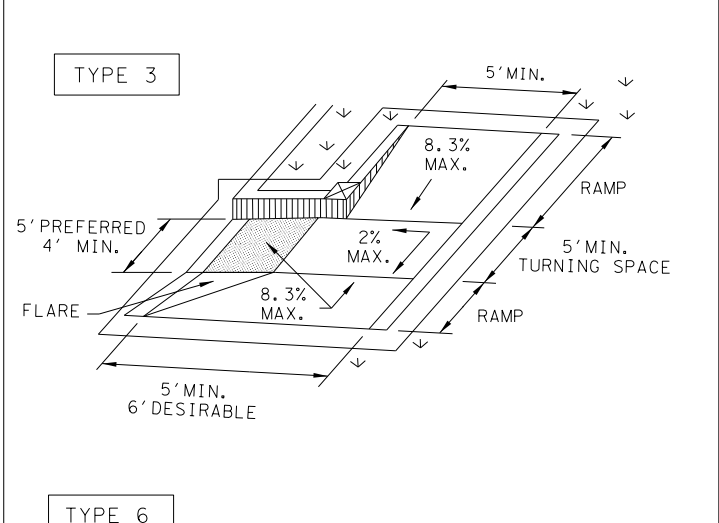
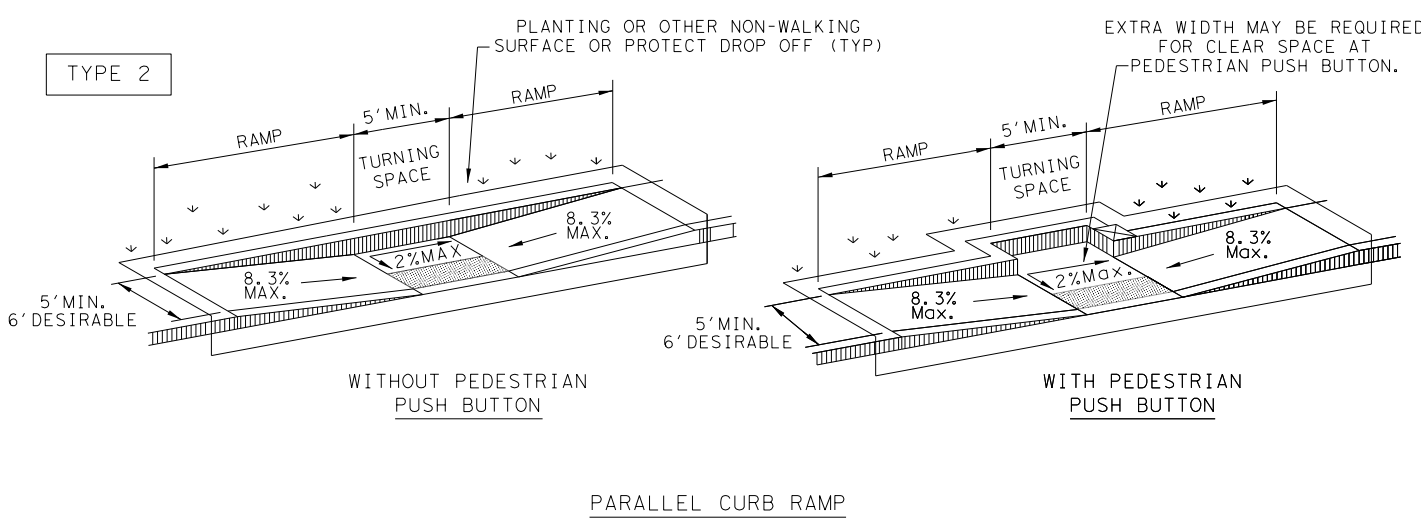
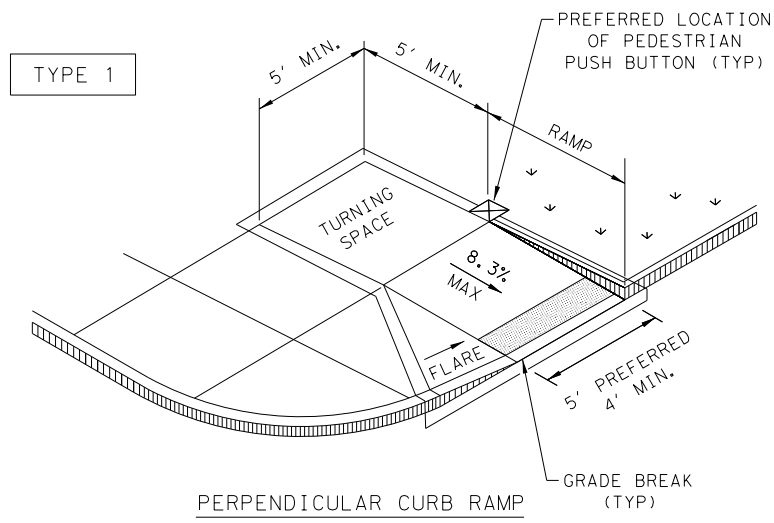

NOTES / LEGEND:
SEE GENERAL NOTES ON SHEET 2 OF 4 FOR MORE INFORMATION.

DENOTES PLANTING OR NON-WALKING SURFACE NOT PART OF PEDESTRIAN CIRCULATION PATH.

DENOTES PREFERRED LOCATION OF PEDESTRIAN PUSH BUTTON IF APPLICABLE.

Detectable Warning Surface: [Symbol]

Grade Break: [Symbol]

Ramp Limits of Payment: [Symbol]

Gutter Line: [Symbol]

SHEET 1 OF 4

Design Division Standard

PEDESTRIAN FACILITIES CURB RAMPS

PED-18

FILE: ped18	DN: TxDOT	DW: VP	CK: KM	CK: PK & JG
© TxDOT: MARCH, 2002	CONT	SECT	JOB	HIGHWAY
REVISED 08, 2005	0910	16	165	MLK JR
REVISED 06, 2012	DIST	COUNTY		SHEET NO.
REVISED 01, 2018	TYLER	SMITH		35

DISCLAIMER: The use of this standard is governed by the "Texas Engineering Practice Act". No warranty of any kind is made by TxDOT for any purpose whatsoever. TxDOT assumes no responsibility for the conversion of this standard to other formats or for incorrect results or damages resulting from its use.

DATE: FILE:

GENERAL NOTES

CURB RAMP

1. Install a curb ramp or blended transition at each pedestrian street crossing.
2. All slopes shown are maximum allowable. Cross slopes of 1.5% and lesser running should be used. Adjust curb ramp length or grade of approach sidewalks as directed.
3. Maximum allowable cross slope on sidewalk and curb ramp surfaces is 2%.
4. The minimum sidewalk width is 5'. Where the sidewalk is adjacent to the back of curb, a 6' sidewalk width is desirable. Where a 5' sidewalk cannot be provided due to site constraints, sidewalk width may be reduced to 4' for short distances. 5' x 5' passing areas at intervals not to exceed 200' are required.
5. Turning Spaces shall be 5' x 5' minimum. Cross slope shall be maximum 2%.
6. Clear space at the bottom of curb ramps shall be a minimum of 4' x 4' wholly contained within the crosswalk and wholly outside the parallel vehicular travel path.
7. Provide flared sides where the pedestrian circulation path crosses the curb ramp. Flared sides shall be sloped at 10% maximum, measured parallel to the curb. Returned curbs may be used only where pedestrians would not normally walk across the ramp, either because the adjacent surface is planted, substantially obstructed, or otherwise protected.
8. Additional information on curb ramp location, design, light reflective value and texture may be found in the latest draft of the Proposed Guidelines for Pedestrian Facilities in the Public Right of Way (PROWAG) as published by the U.S. Architectural and Transportation Barriers Compliance Board (Access Board).
9. To serve as a pedestrian refuge area, the median should be a minimum of 6' wide, measured from back of curbs. Medians should be designed to provide accessible passage over or through them.
10. Small channelization islands, which do not provide a minimum 5' x 5' landing at the top of curb ramps, shall be cut through level with the surface of the street.
11. Crosswalk dimensions, crosswalk markings and stop bar locations shall be as shown elsewhere in the plans. At intersections where crosswalk markings are not required, curb ramps shall align with theoretical crosswalks unless otherwise directed.
12. Provide curb ramps to connect the pedestrian access route at each pedestrian street crossing. Handrails are not required on curb ramps.
13. Curb ramps and landings shall be constructed and paid for in accordance with Item 531 "Sidewalks".
14. Place concrete at a minimum depth of 5" for ramps, flares and landings, unless otherwise directed.
15. Furnish and install No. 3 reinforcing steel bars at 18" o.c. both ways, unless otherwise directed.
16. Provide a smooth transition where the curb ramps connect to the street.
17. Curbs shown on sheet 1 within the limits of payment are considered part of the curb ramp for payment, whether it is concrete curb, gutter, or combined curb and gutter.
18. Existing features that comply with applicable standards may remain in place unless otherwise shown on the plans.

DETECTABLE WARNING MATERIAL

19. Curb ramps must contain a detectable warning surface that consists of raised truncated domes complying with PROWAG. The surface must contrast visually with adjoining surfaces, including side flares. Furnish and install an approved cast-in-place dark brown or dark red detectable warning surface material adjacent to uncolored concrete, unless specified elsewhere in the plans.
20. Detectable Warning Materials must meet TxDOT Departmental Materials Specification DMS 4350 and be listed on the Material Producer List. Install products in accordance with manufacturer's specifications.
21. Detectable warning surfaces must be firm, stable and slip resistant.
22. Detectable warning surfaces shall be a minimum of 24 inches in depth in the direction of pedestrian travel, and extend the full width of the curb ramp or landing where the pedestrian access route enters the street.
23. Detectable warning surfaces shall be located so that the edge nearest the curb line is at the back of curb and neither end of that edge is greater than 5 feet from the back of curb. Detectable warning surfaces may be curved along the corner radius.
24. Shaded areas on Sheet 1 of 4 indicate the approximate location for the detectable warning surface for each curb ramp type.

DETECTABLE WARNING PAVERS (IF USED)

25. Furnish detectable warning paver units meeting all requirements of ASTM C-936, C-33. Lay in a two by two unit basket weave pattern or as directed.
26. Lay full-size units first followed by closure units consisting of at least 25 percent (25%) of a full unit. Cut detectable warning paver units using a power saw.

SIDEWALKS

27. Provide clear ground space at operable parts, including pedestrian push buttons. Operable parts shall be placed within unobstructed reach range specified in PROWAG section R406.
28. Place traffic signal or illumination poles, ground boxes, controller boxes, signs, drainage facilities and other items so as not to obstruct the pedestrian access route or clear ground space.
29. Street grades and cross slopes shall be as shown elsewhere in the plans.
30. Changes in level greater than 1/4 inch are not permitted.
31. The least possible grade should be used to maximize accessibility. The running slope of sidewalks and crosswalks within the public right of way may follow the grade of the parallel roadway. Where a continuous grade greater than five percent (5%) must be provided, handrails may be desirable to improve accessibility. Handrails may also be needed to protect pedestrians from potentially hazardous conditions. If provided, handrails shall comply with PROWAG R409.
32. Handrail extensions shall not protrude into the usable landing area or into intersecting pedestrian routes.
33. Driveways and turnouts shall be constructed and paid for in accordance with Item "Intersections, Driveways and Turnouts". Sidewalks shall be constructed and paid for in accordance with Item, "Sidewalks".
34. Sidewalk details are shown elsewhere in the plans.

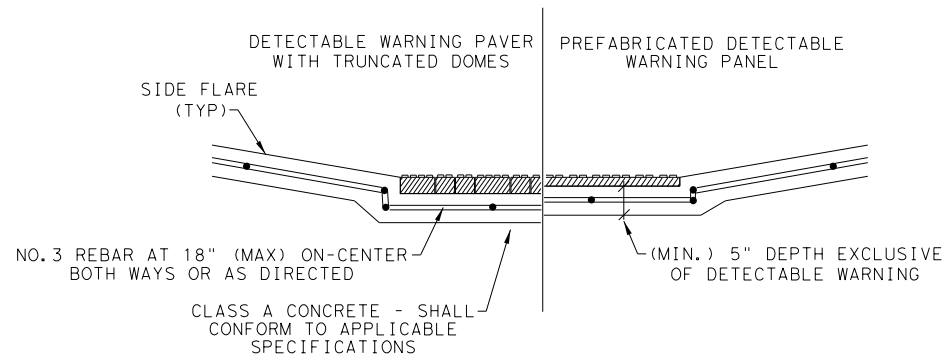

SECTION VIEW DETAIL
CURB RAMP AT DETECTIBLE WARNINGS

DETECTABLE WARNING SURFACE DETAILS

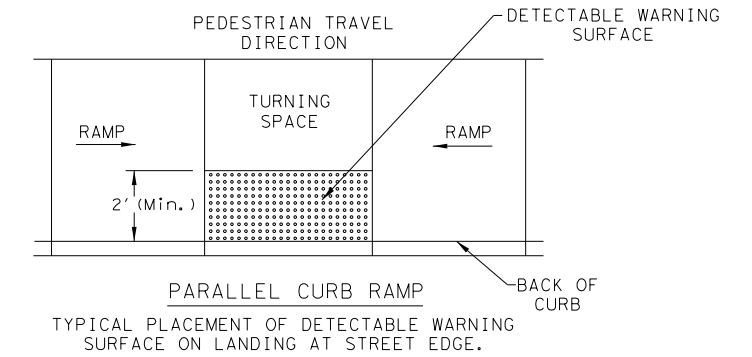

PARALLEL CURB RAMP
TYPICAL PLACEMENT OF DETECTABLE WARNING SURFACE ON LANDING AT STREET EDGE.

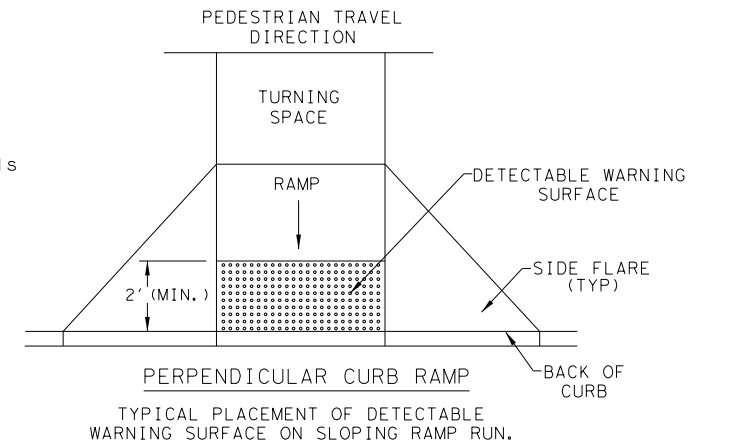

PERPENDICULAR CURB RAMP
TYPICAL PLACEMENT OF DETECTABLE WARNING SURFACE ON SLOPING RAMP RUN.

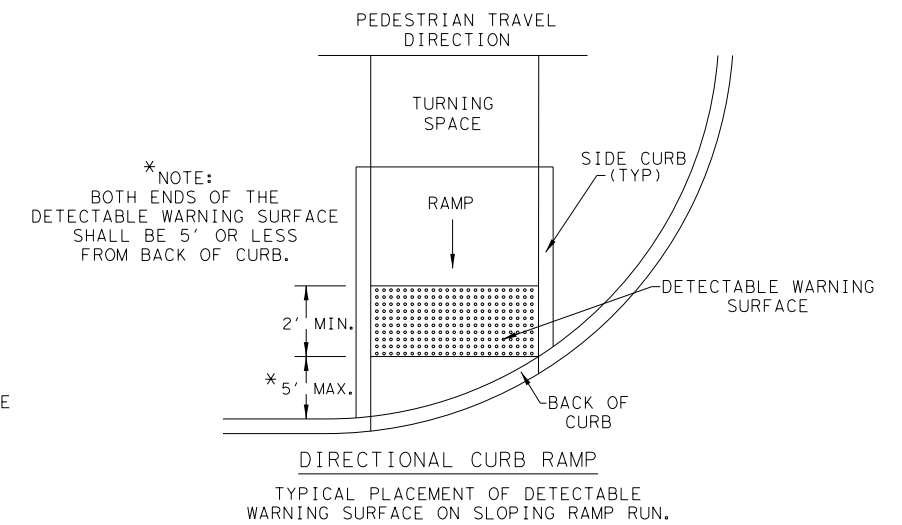

DIRECTIONAL CURB RAMP
TYPICAL PLACEMENT OF DETECTABLE WARNING SURFACE ON SLOPING RAMP RUN.

SHEET 2 OF 4

Texas Department of Transportation		Design Division Standard		
<h1 style="margin: 0;">PEDESTRIAN FACILITIES</h1> <h2 style="margin: 0;">CURB RAMPS</h2> <h3 style="margin: 0;">PED-18</h3>				
FILE: ped18	DN: TxDOT	DW: VP	CK: KM	CK: PK & JG
© TxDOT: MARCH, 2002	CONT	SECT	JOB	HIGHWAY
REVISIONS	0910	16	165	MLK JR
REVISED 08, 2005	DIST	COUNTY	SHEET NO.	
REVISED 06, 2012	TYLER	SMITH	36	
REVISED 01, 2018				

DISCLAIMER: The use of this standard is governed by the "Texas Engineering Practice Act". No warranty of any kind is made by TxDOT for any purpose whatsoever. TxDOT assumes no responsibility for the conversion of this standard to other formats or for incorrect results or damages resulting from its use.

SIDEWALK TREATMENT AT DRIVEWAYS

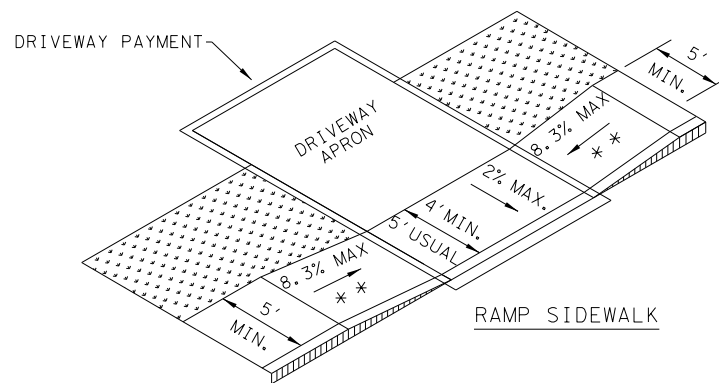
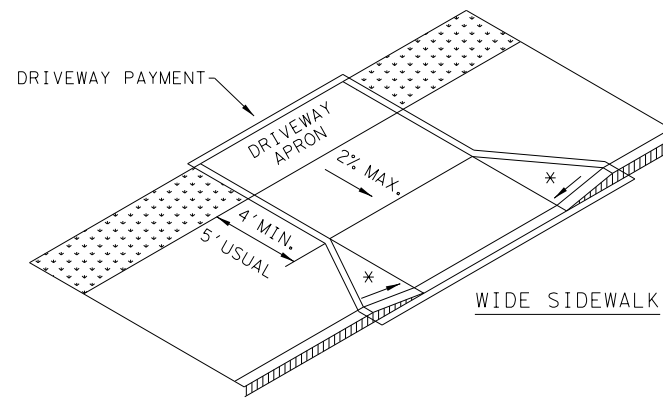
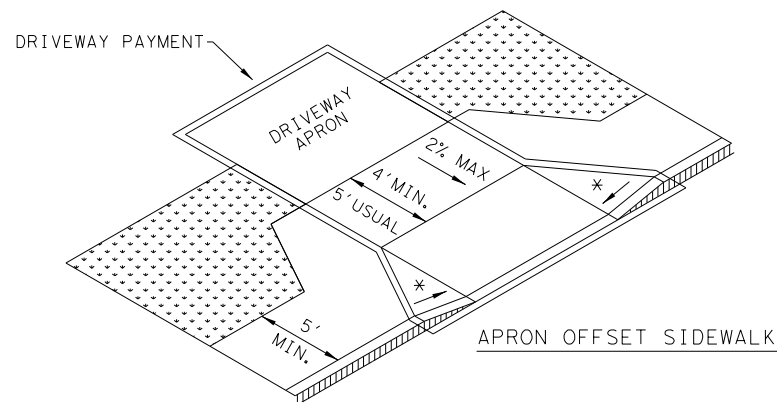
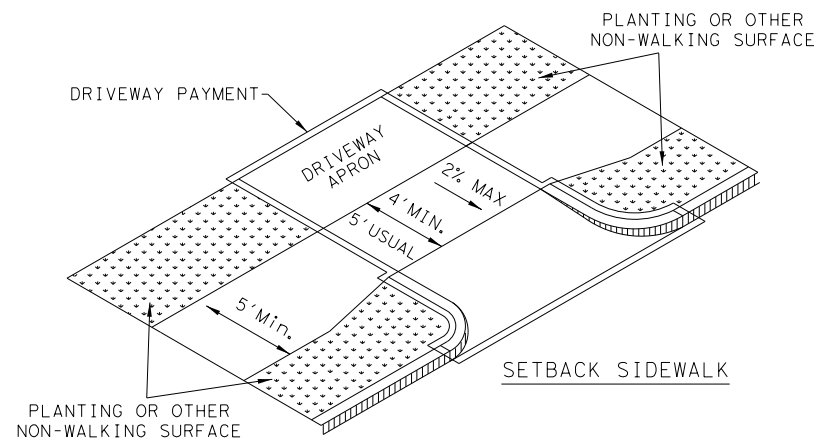

NOTES:

* WHERE DRIVEWAYS CROSS THE PEDESTRIAN ROUTE, SIDES SHALL BE FLARED AT 10% MAX SLOPE.

* * IF CURB HEIGHT IS GREATER THAN 6 INCHES, USE GRADE LESS THAN OR EQUAL TO 5%. HANDRAIL AND DETECTABLE WARNING ARE NOT REQUIRED.

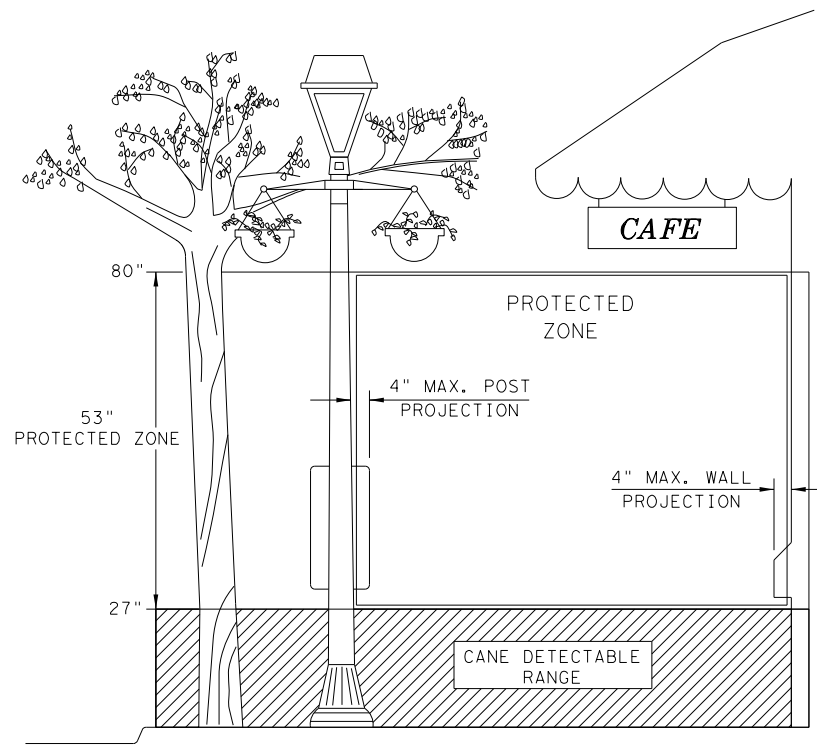

PROTECTED ZONE

NOTE: IN PEDESTRIAN CIRCULATION AREA, MAXIMUM 4" PROJECTION FOR POST OR WALL MOUNTED OBJECTS BETWEEN 27" AND 80" ABOVE THE SURFACE.

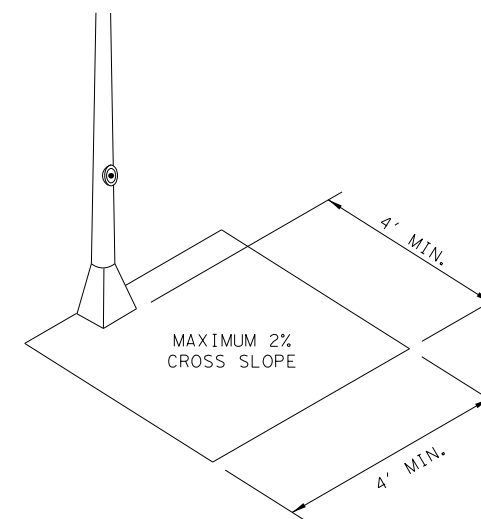

CLEAR SPACE ADJACENT TO PEDESTRIAN PUSH BUTTON

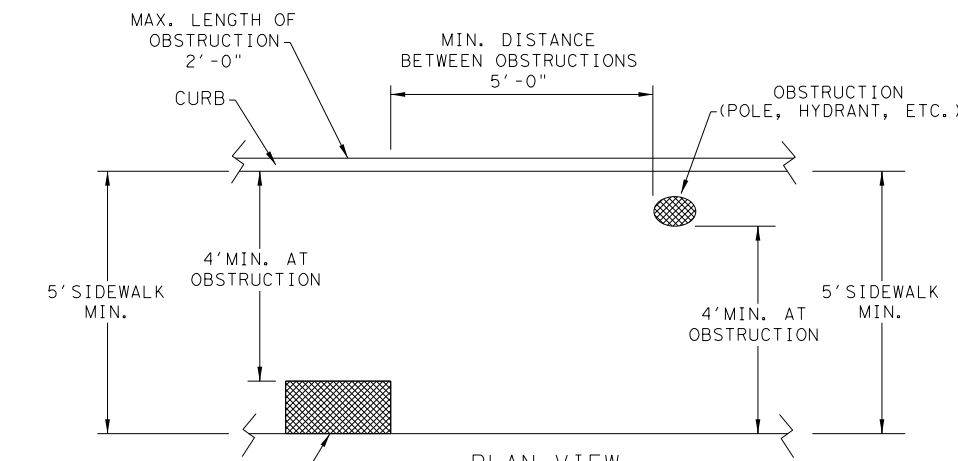

PLAN VIEW
PLACEMENT OF STREET FIXTURES

NOTE: ITEMS NOT INTENDED FOR PUBLIC USE. MINIMUM 4' X 4' CLEAR GROUND SPACE REQUIRED AT PUBLIC USE FIXTURES.

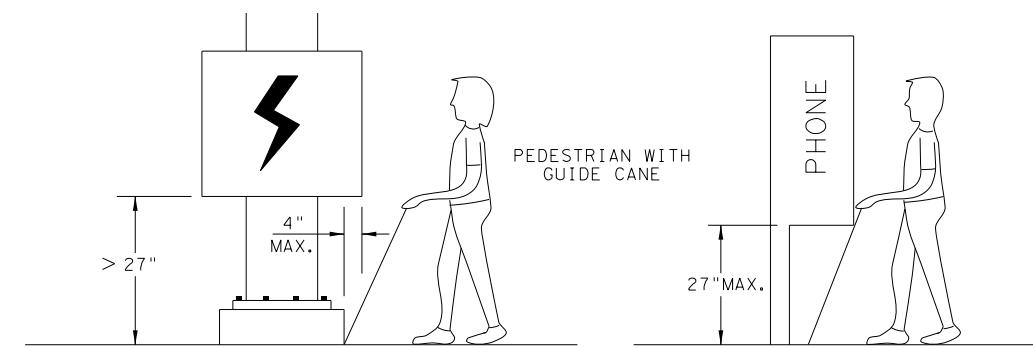

WHEN AN OBSTRUCTION OF A HEIGHT GREATER THAN 27" FROM THE SURFACE WOULD CREATE A PROTRUSION OF MORE THAN 4" INTO THE PEDESTRIAN CIRCULATION AREA, CONSTRUCT ADDITIONAL CURB OR FOUNDATION AT THE BOTTOM TO PROVIDE A MAXIMUM 4" OVERHANG.

PROTRUDING OBJECTS OF A HEIGHT $\leq 27"$ ARE DETECTABLE BY CANE AND DO NOT REQUIRE ADDITIONAL TREATMENT.

DETECTION BARRIER FOR VERTICAL CLEARANCE < 80"

SHEET 3 OF 4



PEDESTRIAN FACILITIES
CURB RAMPS

PED-18

FILE: ped18	DN: TxDOT	DW: VP	CK: KM	CK: PK & JG
© TxDOT: MARCH, 2002	CONT	SECT	JOB	HIGHWAY
REVISIONS	0910	16	165	MLK JR
REVISED 08, 2005	DIST	COUNTY	SHEET NO.	
REVISED 06, 2012	TYLER	SMITH	37	
REVISED 01, 2018				

DATE:
FILE:

DISCLAIMER: The use of this standard is governed by the "Texas Engineering Practice Act". No warranty of any kind is made by TxDOT for any purpose whatsoever. TxDOT assumes no responsibility for the conversion of this standard to other formats or for incorrect results or damages resulting from its use.

TYPICAL CROSSING LAYOUTS
SEE SHEET 1 OF 4 FOR DETAILS AND DIMENSIONS

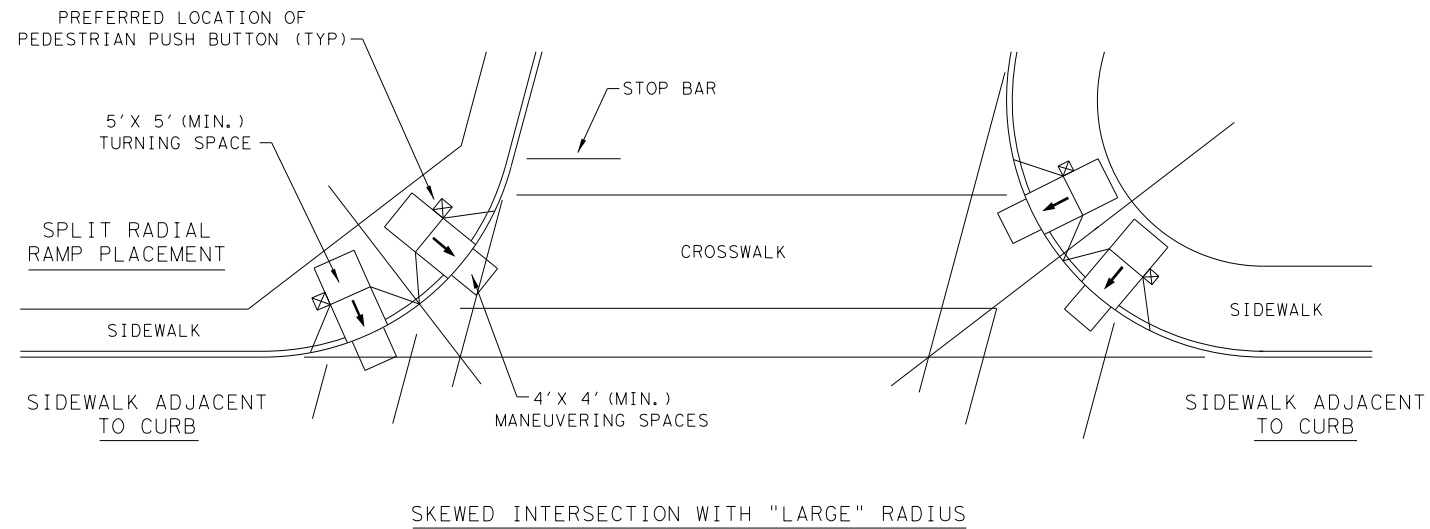

SKewed INTERSECTION WITH "LARGE" RADIUS

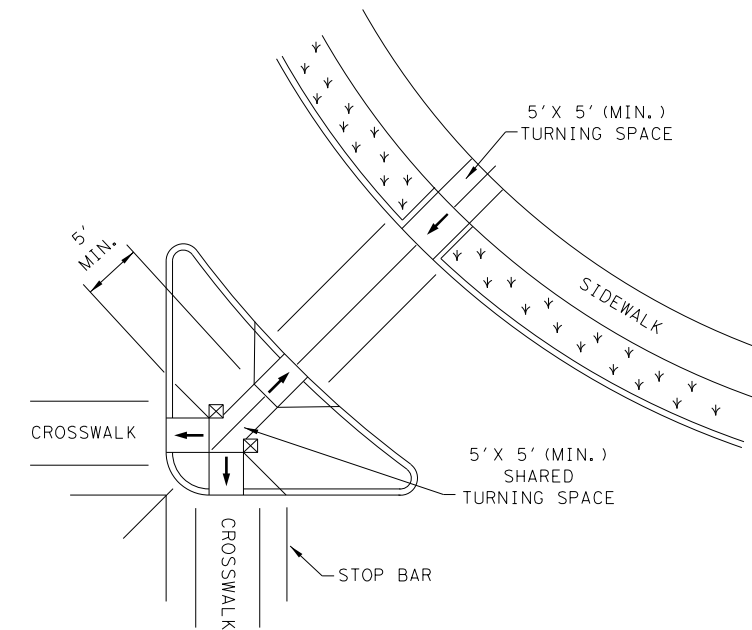

AT INTERSECTION
W/FREE RIGHT TURN & ISLAND

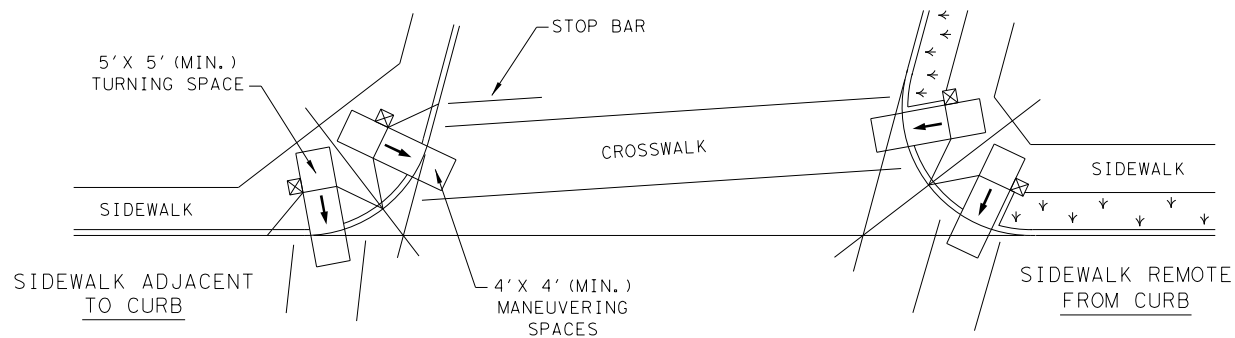

SKewed INTERSECTION WITH "SMALL" RADIUS

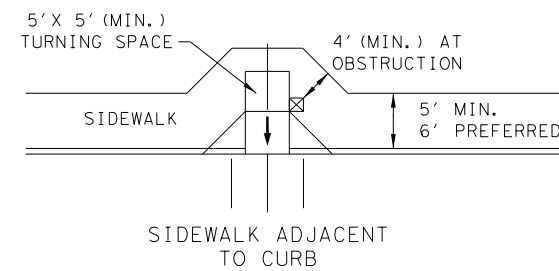

SIDEWALK ADJACENT TO CURB

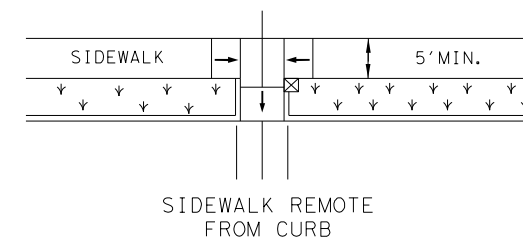

SIDEWALK REMOTE FROM CURB

MID-BLOCK PLACEMENT PERPENDICULAR RAMPS

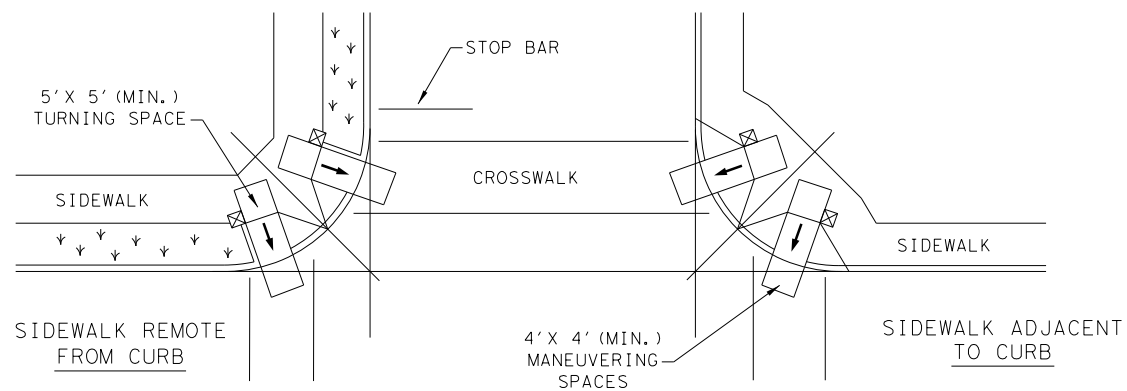

NORMAL INTERSECTION WITH "SMALL" RADIUS

LEGEND:

SHOWS DOWNWARD SLOPE. →

DENOTES PREFERRED LOCATION OF PEDESTRIAN PUSH BUTTON (IF APPLICABLE). ◻

DENOTES PLANTING OR NON-WALKING SURFACE NOT PART OF PEDESTRIAN CIRCULATION PATH. ↙ ↘ ↙ ↘ ↙ ↘

SHEET 4 OF 4



PEDESTRIAN FACILITIES
CURB RAMPS

PED-18

FILE: ped18	DN: TxDOT	DW: VP	CK: KM	CK: PK & JG
© TxDOT: MARCH, 2002	CONT	SECT	JOB	HIGHWAY
REVISIONS	0910	16	165	MLK JR
REVISED 08, 2005	DIST	COUNTY	SHEET NO.	
REVISED 06, 2012	TYLER	SMITH	38	
REVISED 01, 2018				

DATE:
FILE:

DISCLAIMER: The use of this standard is governed by the "Texas Engineering Practice Act". No warranty of any kind is made by TxDOT for any purpose whatsoever. TxDOT assumes no responsibility for the conversion of this standard to other formats or for incorrect results or damages resulting from its use.

DATE: FILE:

GENERAL NOTES FOR ALL ELECTRICAL WORK

- The location of all conduits, junction boxes, ground boxes, and electrical services is diagrammatic and may be shifted to accommodate field conditions.
- Provide new and unused materials. Ensure that all materials and installations comply with the applicable articles of the National Electrical Code (NEC), TxDOT standards and specifications, National Electrical Manufacturers Association (NEMA), and are listed by Underwriters Laboratories (UL) or a Nationally Recognized Testing Lab (NRTL). NRTLs such as Canadian Standard Association (CSA), Intertek Testing Services NA Inc., or FM Approvals LLC can be considered equivalent to UL. Where reference is made to NEMA listed devices, International Electrotechnical Commission (IEC) listed devices will not be considered an acceptable equal to a NEMA listed device. Acceptable devices may have both a NEMA and IEC listing. Faulty fabrication or poor workmanship in any material, equipment, or installation is justification for rejection. Replace or reinstall rejected material or equipment at no additional cost to the Department.
- Miscellaneous nuts, bolts and hardware, except for high strength bolts, may be stainless steel when plans specify galvanized, provided the bolt size is 1/2 in. or less in diameter.
- Provide the following test equipment as required by the Engineer to confirm compliance with the contract and the NEC: voltmeter, ammeter, megohm meter (1000 volt DC), ground resistance tester, torque wrenches, and torque screwdrivers. Ensure all equipment has been properly calibrated within the last year. Provide calibration certification to the Engineer upon request. Operate test equipment during inspection as requested by the Engineer.
- Install grounding as shown on the plans and in accordance with the NEC. Ensure all metallic conduits; metal poles; luminaires; and metal enclosures are bonded to the equipment grounding conductor. Provide stranded bare copper or green insulated grounding conductors. Ground rods, connectors, and bonding jumpers are subsidiary to the various bid items.
- When required by the Engineer, notify the Department in writing of materials from the Material Producers List (MPL) intended for use on each project. Prequalified materials are listed on the MPL on TxDOT's website under "Roadway Illumination and Electrical Supplies." No substitutions will be allowed for materials on this list.

CONDUIT

A. MATERIALS

- Provide conduit, junction boxes, fittings, and hardware as per TxDOT Departmental Material Specification (DMS) 11030 "Conduit" and Item 618 "Conduit" of TxDOT's "Standard Specifications For Construction And Maintenance Of Highways, Streets, And Bridges," latest edition. Provide conduits listed under Item 618 on the MPL under "Roadway Illumination and Electrical Supplies." Provide conduit types according to the descriptive code or as shown on the plans. Do not substitute other types of conduits for those shown. Provide liquidtight flexible metal conduit (LFMC) when flexible conduit is called for on galvanized steel rigid metallic conduit (RMC) systems. Provide liquidtight flexible nonmetallic conduit (LFNC) when flexible conduit is called for on polyvinyl chloride (PVC) systems.
- Provide galvanized steel RMC for all exposed conduits, unless otherwise shown on the plans. Properly bond all metal conduits.
- Unless otherwise shown on the plans, provide junction boxes with a minimum size as shown in the following table, which applies to the greatest number of conductors entering the box through one conduit with no more than four conduits per box. When a mixture of conductor sizes is present, count the conductors as if all are of the larger size. For situations not applicable to the table, size junction boxes in accordance with NEC.

AWG	3 CONDUCTORS	5 CONDUCTORS	7 CONDUCTORS
#1	10" x 10" x 4"	12" x 12" x 4"	16" x 16" x 4"
#2	8" x 8" x 4"	10" x 10" x 4"	12" x 12" x 4"
#4	8" x 8" x 4"	10" x 10" x 4"	10" x 10" x 4"
#6	8" x 8" x 4"	8" x 8" x 4"	10" x 10" x 4"
#8	8" x 8" x 4"	8" x 8" x 4"	8" x 8" x 4"

- Junction boxes with an internal volume of less than 100 cu. in. and supported by entering raceways must have threaded entries or hubs identified for the intended purpose and supported by connection of two or more rigid metal conduits. Secure conduit within 3 ft. of the enclosure or within 18 in. of the enclosure if all conduit entries are on the same side. Mechanically secure all junction boxes with an internal volume greater than 100 cu. inches.
- Provide hot dipped galvanized cast iron or sand cast aluminum outlet boxes for junction boxes containing only 10 AWG or 12 AWG conductors. Do not use die cast aluminum boxes. Size outlet boxes according to the NEC.
- Do not use intermediate metal conduit (IMC) or electrical metallic tubing (EMT) unless specifically required by the plan sheets. When EMT is called for, provide junction boxes made from galvanized steel sheeting, listed and approved for outdoor use, unless otherwise noted on the plans. Size all galvanized steel junction boxes in accordance with the NEC. Provide junction boxes for IMC conduit systems that meet the same requirements for junction boxes used with RMC systems.
- Provide PVC junction boxes intended for outdoor use on PVC conduit systems, unless otherwise noted on the plans.

- Provide PVC elbows in PVC conduit systems, unless otherwise shown on the plans. Use only a flat, high tensile strength polyester fiber pull tape for pulling conductors through the PVC conduit system. When galvanized steel RMC elbows are specifically called for in the plans and any portion of the RMC elbow is buried less than 18 in., ground the RMC elbow by means of a grounding bushing on a rigid metal extension. Grounding of the rigid metal elbow is not required if the entire RMC elbow is encased in a minimum of 2 in. of concrete. PVC extensions are allowed on these concrete encased rigid metal elbows. RMC or PVC elbows are subsidiary to various bid items.
- When required, provide High-Density Polyethylene (HDPE) conduit with factory installed internal conductors according to Item 622 "Duct Cable." At the Contractor's request and with approval by the Engineer, substitute HDPE conduit with no conductors for bored schedule 40 or schedule 80 PVC conduit bid under Item 618. Ensure bored HDPE substituted for PVC is schedule 40 and of the same size PVC called for in the plans. Ensure the substituted HDPE meets the requirements of Item 622, except that the conduit is supplied without factory-installed conductors. Make the transition of the HDPE conduit to PVC (or RMC elbow when required) at the bore pit. Provide conduit of the size and schedule as shown on the plans. Do not extend substituted conduit into ground boxes or foundations. Provide PVC or galvanized steel RMC elbows as called for at all ground boxes and foundations.
- Use two-hole straps when supporting 2 in. and larger conduits. On electrical service poles, properly sized stainless steel or hot dipped galvanized one-hole standoff straps are allowed on the service riser conduit.

B. CONSTRUCTION METHODS

- Provide and install expansion joint conduit fittings on all structure-mounted conduits at the structure's expansion joints to allow for movement of the conduit. In addition, provide and install expansion joint fittings on all continuous runs of galvanized steel RMC conduit externally exposed on structures such as bridges at maximum intervals of 150 ft. When requested by the project Engineer, supply manufacturer's specification sheet for expansion joint conduit fittings. Repair or replace expansion joint fittings that do not allow for movement at no additional cost to the Department. Provide the method of determining the amount of expansion to the Engineer upon request. Do not use LFMC or LFNC as a substitute for the required expansion conduit fittings.
- Space all conduit supports at maximum intervals of 5 ft. Install conduit spacers when attaching metal conduit to surface of concrete structures. See "Conduit Mounting Options" on ED(2). Install conduit support within 3 ft. of all enclosures and conduit terminations.
- Do not attach conduit supports directly to pre-stressed concrete beams except as shown specifically in the plans or as approved by the Engineer.
- Unless otherwise shown on the plans, jack or bore conduit placed beneath existing roadways, driveways, sidewalks, or after the base or surfacing operation has begun. Backfill and compact the bore pits below the conduit per Item 476 "Jacking, Boring, or Tunneling Pipe or Box" prior to installing conduit or duct cable to prevent bending of the connections.
- When placing conduit in the sub-grade of new roadways, backfill all trenches with excavated material unless otherwise noted on the plans. When placing conduit in the sub-base of new roadways, backfill all trenches with cement-stabilized base as per requirements of Items 110 "Excavation", 400 "Excavation and Backfill for Structures", 401 "Flowable Backfill", 402 "Trench Excavation Protection", and 403 "Temporary Special Shoring."
- Provide and place warning tape approximately 10 in. above all trenched conduit as per Item 618.
- During construction, temporarily cap or plug open ends of all conduit and raceways immediately after installation to prevent entry of dirt, debris and animals. Temporary caps constructed of durable duct tape are allowed. Tightly fix the tape to the conduit opening. Clean out the conduit and prove it clear in accordance with Item 618 prior to installing any conductors.
- Ensure conduit entry into the top of any enclosure is waterproof by installing conduit sealing hubs or using boxes with threaded bosses. This includes surface mounted safety switches, meter cans, service enclosures, auxiliary enclosures and junction boxes. Grounding bushings on water tight sealing hubs are not required.
- Fit the ends of all PVC conduit terminations with bushings or bell end fittings. Provide and install a grounding type bushing on all metal conduit terminations.
- Install a bonding jumper from each grounding bushing to the nearest ground rod, grounding lug, or equipment grounding conductor. Ensure all bonding jumpers are the same size as the equipment grounding conductor. Bonding of conduit used as a casing under roadways for duct cable is not required, if the duct extends the full length through the casing.
- At all electrical services, install a 6 AWG solid copper grounding electrode conductor.
- Place conduits entering ground boxes so that the conduit openings are between 3 in. and 6 in. from the bottom of the box. See the ground box detail on sheet ED(4).
- Seal ends of all conduits with duct seal, expandable foam, or by other methods approved by the Engineer. Seal conduit immediately after completion of conductor installation and pull tests. Do not use duct tape as a permanent conduit sealant. Do not use silicone caulk as a conduit sealant.
- File smooth the cut ends of all mounting strut and conduit. Before installing, paint the field cut ends of all mounting strut and RMC (threaded or non-threaded) with zinc rich paint (94% or more zinc content) to alleviate overspray. Use zinc rich paint to touch up galvanized material as allowed under Item 445 "Galvanizing." Do not paint non-galvanized material with a zinc rich paint as an alternative for materials required to be galvanized.

				Traffic Operations Division Standard	
<h1>ELECTRICAL DETAILS CONDUITS & NOTES</h1>					
<h2>ED(1) - 14</h2>					
FILE:	ed1-14.dgn	DN:	CK:	DW:	CK:
© TxDOT	October 2014	CONT	SECT	JOB	HIGHWAY
REVISIONS		0910	16	165	MLK JR
		DIST	COUNTY		SHEET NO.
		TYLER	SMITH		39

ELECTRICAL CONDUCTORS

A. MATERIAL INFORMATION

1. Provide Type XHHW insulated conductors in accordance with Departmental Material Specification (DMS)11040 "Conductors" and Item 620 "Electrical Conductors." Provide conductors as listed on the Material Producers List (MPL) on the Department web site under "Roadway Illumination and Electrical Supplies" Item 620. Color code insulated conductors in conformance with the NEC. Identify grounded (neutral) conductors with white insulation. Identify grounding conductors (ground wires) with green insulation or bare conductors. Identify ungrounded (hot) conductors with any color insulation except green, white, or gray. Keep color scheme consistent throughout the wiring system. Identify conductors 6 American Wire Gauge (AWG) and smaller by continuous color jacket. Identify electrical conductors 4 AWG and larger by continuous color jacket or by colored tape. When identifying conductors with colored tape, mark at least 6 in. of the conductor's insulation with half laps of tape.
2. Provide a solid copper 6 AWG grounding electrode conductor to bond the electrical service equipment to the concrete encased grounding electrode or the ground rod at the service location. Connect the grounding electrode conductor to the ground rod with a UL listed connector in accordance with DMS 11040. Connect the grounding electrode conductor to the concrete encased grounding electrode as shown in the plans.
3. Where two or more circuits are present in one conduit or enclosure, permanently identify the conductors of each branch circuit by attaching a non-metallic tag around both circuit conductors at each accessible location. Provide tags with two straps, large enough to indicate circuit number, letter, or other identification as shown in the plans. Print circuit identification on the tag with a permanent marker.
4. Use listed compression or screw type pressure connectors, terminal blocks, or split bolt connectors for splicing as specified in DMS 11040. Use hot melt adhesive tape to fill the gap and seal the ends of heat shrink tubing. Provide UL listed gel-filled insulating splice covers. Splicing materials, insulating materials, breakaway disconnects, splice covers, and fuse holders are subsidiary to various bid items.

B. CONSTRUCTION METHODS

1. Use only a flat, high tensile strength polyester fiber pull tape for pulling conductors through the conduit system. After installing conductors in conduit, perform conductor pull test. If a conductor cannot be freely pulled, make any needed alterations or repairs at no additional cost to the department. Perform insulation resistance tests in accordance with Item 620. Coordinate with the Engineer to witness the tests.
2. Leave 2 ft. minimum, 3 ft. maximum length for each conductor up to the splice in ground boxes. Leave 3 ft. minimum, 4 ft. maximum length of conductor in ground boxes when pulled through with no splice. Leave 1 ft. minimum, 1.5 ft. maximum length of conductor at enclosures, weatherheads and pole bases.
3. Make splices only in junction boxes, ground boxes, pole bases, or electrical enclosures and use only listed compression or screw type pressure connectors, terminal blocks, or split bolt connectors. Insulate splices with heavy wall heat shrink tubing or gel-filled insulating splice covers to provide a watertight splice. Overlap conductor insulation with heat shrink tubing a minimum of 2 in. past both sides of the splice. Where heat shrink tubing may not shrink sufficiently to provide a watertight seal around the individual conductors, prior to heating the tubing, increase the diameter of the conductor insulation using hot melt adhesive tape to provide a watertight seal between the individual conductors and the heat shrink tubing. Ensure the tape extends past the heat shrink tubing. Use hot melt adhesive tape to fill the gap and seal the ends of heat shrink tubing. Heat shrink tubing that appears to have been burned, or overheated, is considered defective and must be replaced.
4. Size and install gel-filled insulating splice covers according to manufacturer's specifications when used in place of heat shrink tubing.
5. Wire nuts with factory applied waterproof sealant may be used for 8 AWG or smaller conductors in above ground junction boxes, but not in pole bases or ground boxes. Install wire nuts in an upright position to prevent the accumulation of water.
6. Support conductors in illumination poles with a J-hook at the top of the pole.
7. When terminating conductors, remove the insulation and jacketing material without nicking the individual strands of the conductor. Conductors with nicked individual conductor strands or removed strands will be considered damaged.
8. Replace conductors and cables that are damaged beyond repair or that fail an insulation resistance test at no additional cost to the department.
9. Do not repair damaged conductors with duct tape, electrical tape, or wire nuts. Use only approved splicing methods.
10. Do not terminate more than one conductor under a single connector, unless the connector is rated for multiple conductors. Do not exceed the pressure connector's listing for maximum number and size of conductors allowed.
11. Install breakaway connectors on conductors bid under Item 620 whenever those conductors pass through a breakaway support device. Follow manufacturer's instructions when terminating conductors to breakaway connectors. Properly torque threaded connections. Proper terminations are critical to the safe operation of breakaway devices. Trim waterproofing boots on breakaway connectors to fit snugly around the conductor to ensure waterproof connection. Only one conductor may enter a single opening in a boot. Provide waterproof boots with the correct number of openings. Leave unused openings factory sealed. Use prequalified breakaway connectors as shown on the MPL.

12. Provide and install a separate stranded equipment grounding conductor (EGC) in all conduits that contain circuit wiring of 50 volts or more. Unless shown elsewhere, size the EGC to be the same size as the largest current carrying conductor contained in the conduit. Ensure all EGCs are bonded together at every accessible location. For traffic signal installations, provide a minimum size 8 AWG EGC. The EGC is paid for under Item 620.

C. TEMPORARY WIRING

1. Install temporary conductors and electrical equipment in accordance with the NEC article "Temporary Installations" and Department standard sheets.
2. Provide a ground fault circuit interrupter (GFCI) for power outlets for portable electrical equipment, power tools, ice machines, ice storage bins and refrigerators located outdoors at grade. GFCI may be any one of the following: molded cord and plug set, receptacle, or circuit breaker type.
3. Use listed wire nuts with factory applied sealant for temporary wiring where approved.
4. Enclose conductor splices within a listed enclosure or ground box, or ensure the splices are more than 10 ft. above grade vertically and more than 5 ft. horizontally from any metal structure. Where installing temporary conductors in areas subject to vehicle traffic or mobile construction equipment, ensure the vertical clearance to ground is at least 18 ft. when measured at the lowest point. Ground messenger wires that support power conductors in conformance with the NEC.
5. Protect and when necessary repair any existing electrical conduits uncovered during the construction process in a timely manner and in conformance with the NEC.

GROUND RODS & GROUNDING ELECTRODES

A. MATERIAL INFORMATION

1. Provide and install a grounding electrode at electrical services. Provide ground rods according to DMS 11040 and the plans. Larger diameter or longer length rods may be called for in some specific locations, see the individual plans sheets. Concrete encased grounding electrodes may be called for in specific locations including electrical service, see individual plan sheets.

B. CONSTRUCTION METHODS

1. Furnish auxiliary ground rods for lightning protection and install in soil, concrete, or both, as called for in the plans. For ground rods installed in concrete, ensure the connection of the conductor to the ground rod is readily accessible for inspection or repairs. For ground rods installed in soil, ensure that the upper end is between 2 to 4 in. below finished grade.
2. Do not place ground rods in the same drilled hole as a timber pole.
3. Install ground rods so the imprinted part number is at the upper end of the rod.
4. Remove all non-conductive coatings such as concrete splatter from the rod at the clamp location.
5. Route all conductors as short and straight as possible for connection to lightning protection ground rods. When a bend is required, ensure a minimum radius bend of four inches for these conductors.
6. Unless otherwise called for in the plans, protect grounding electrode conductors with non-metallic conduit. When protecting grounding electrode conductors with metal conduit, provide and install a grounding type bushing and properly sized bonding jumper on each end of the metal conduit.
7. Written authorization is required before installing a ground rod in a horizontal trench for rocky soil or a solid rock bottom.

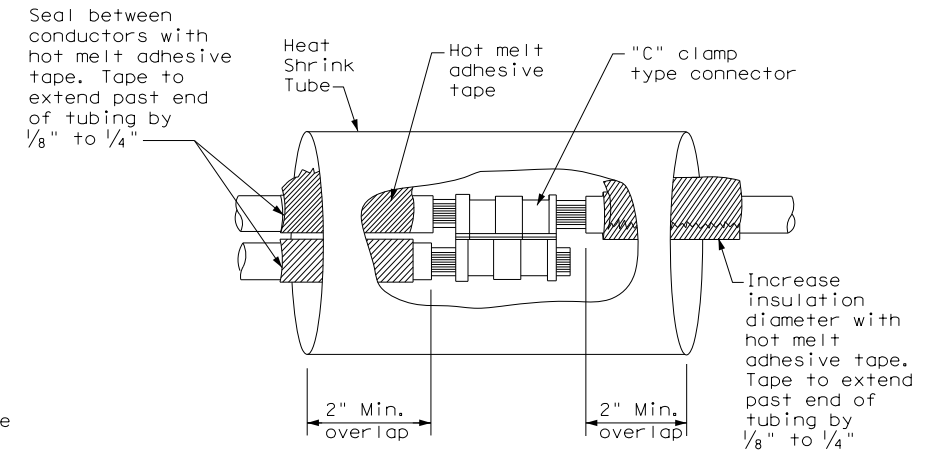

SPLICE OPTION 1
Compression Type

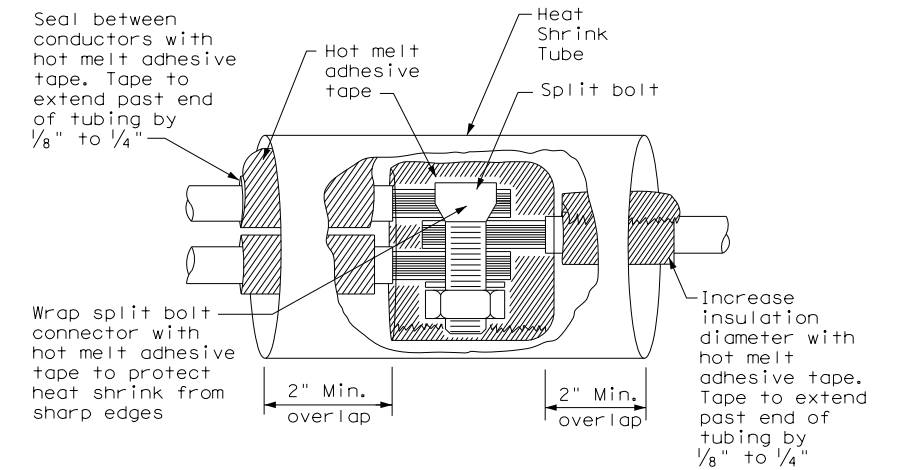

SPLICE OPTION 2
Split Bolt Type

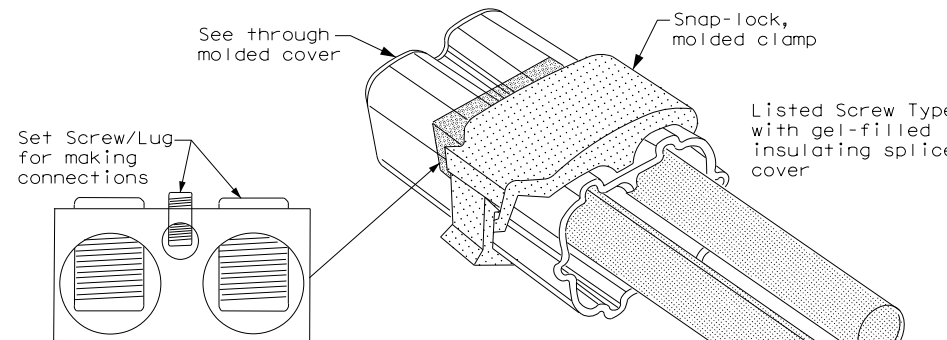

SPLICE OPTION 3
Listed Screw Type

DISCLAIMER: The use of this standard is governed by the "Texas Engineering Practice Act". No warranty of any kind is made by TxDOT for any purpose whatsoever. TxDOT assumes no responsibility for the conversion of this standard to other formats or for incorrect results or damages resulting from its use.

DATE: FILE:

		Texas Department of Transportation		Traffic Operations Division Standard	
<h2>ELECTRICAL DETAILS CONDUCTORS</h2>					
<h3>ED(3) - 14</h3>					
FILE:	ed3-14.dgn	DN:	TxDOT	CK:	TxBOT
© TxDOT	October 2014	CONT:	0910	SECT:	16
REVISIONS		JOB:	165	HIGHWAY:	MLK JR
		DIST:	TYLER	COUNTY:	SMITH
				SHEET NO.:	40

DISCLAIMER: The use of this standard is governed by the "Texas Engineering Practice Act". No warranty of any kind is made by TxDOT for any purpose whatsoever. TxDOT assumes no responsibility for the conversion of this standard to other formats or for incorrect results or damages resulting from its use.

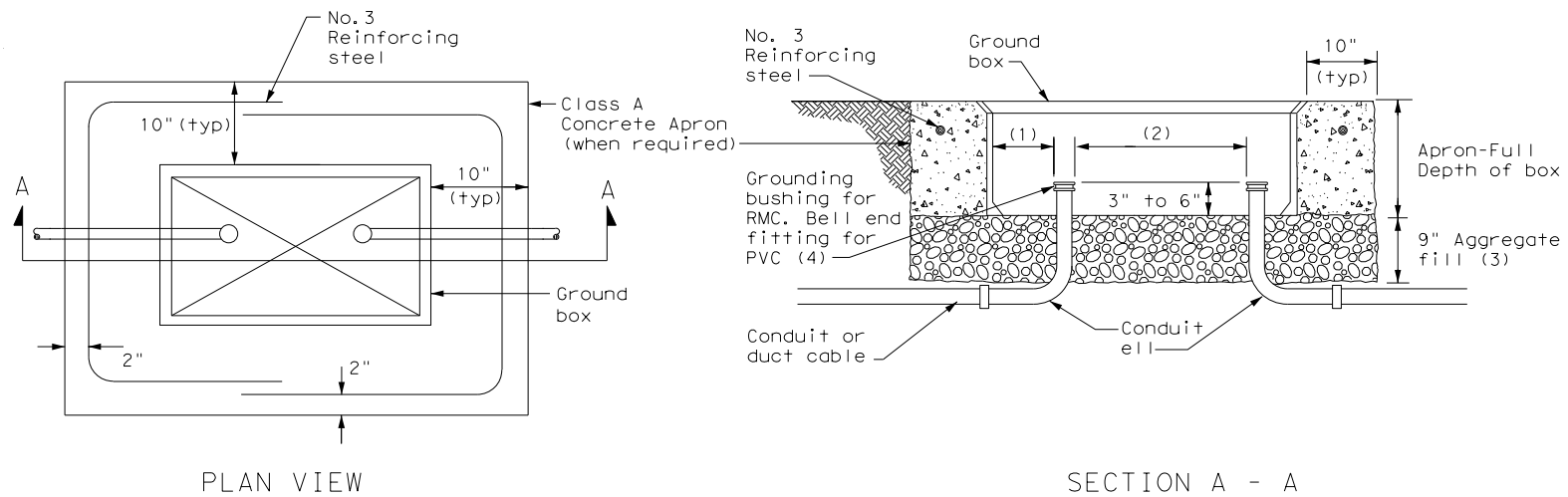

APRON FOR GROUND BOX

- (1) Uniformly space ends of conduits within the ground box. Position ends of conduits so that ground box walls do not interfere with the installation of grounding bushings or bell end fittings.
- (2) Maintain sufficient space between conduits to allow for proper installation of bushings.
- (3) Place aggregate under the box, not in the box. Aggregate should not encroach on the interior volume of the box.
- (4) Install a grounding bushing on the upper end of all RMC terminating in a ground box. Ground RMC elbow when any part of the elbow is less than 18 in. below the bottom of the ground box. Install a PVC bushing or bell end fitting on the upper end of all PVC conduits terminating in a ground box.

GROUND BOX DIMENSIONS

TYPE	OUTSIDE DIMENSIONS (INCHES) (Width x Length X Depth)
A	12 X 23 X 11
B	12 X 23 X 22
C	16 X 29 X 11
D	16 X 29 X 22
E	12 X 23 X 17

GROUND BOX COVER DIMENSIONS

TYPE	DIMENSIONS (INCHES)							
	H	I	J	K	L	M	N	P
A, B & E	23 1/4	23	13 3/4	13 1/2	9 7/8	5 1/8	1 3/8	2
C & D	30 1/2	30 1/4	17 1/2	17 1/4	13 1/4	6 3/4	1 3/8	2

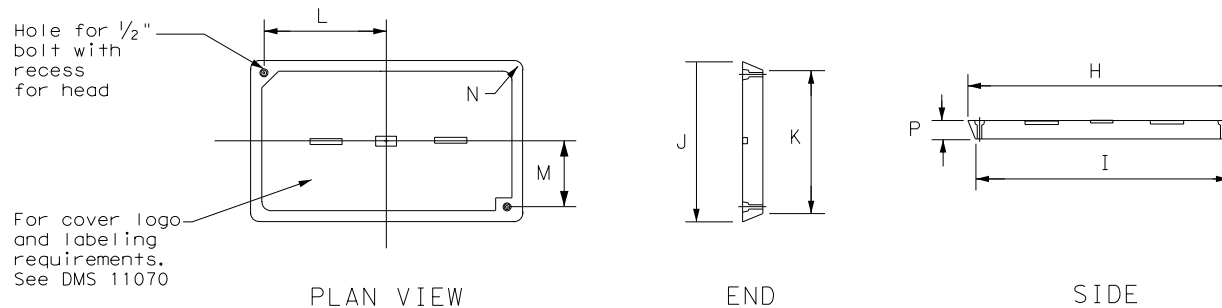

GROUND BOX COVER

GROUND BOXES

A. MATERIALS

1. Provide polymer concrete ground boxes measuring 16x30x24 in. (WxLxD) or smaller in accordance with Departmental Material Specification (DMS) 11070 "Ground Boxes" and Item 624 "Ground Boxes."
2. Provide Type A, B, C, D, and E ground boxes as shown in the plans, and as listed on the Material Producers List (MPL) on the Department web site under "Roadway Illumination and Electrical Supplies," Item 624.

3. Ensure ground box cover is correctly labeled in accordance with DMS 11070.

4. Provide larger ground boxes in accordance with Item 624 and as shown in the plans.

B. CONSTRUCTION METHODS

1. Remove all gravel and dirt from conduit. Cap all conduits prior to placing aggregate and setting ground box. Provide Grade 3 or 4 coarse aggregate as shown on Table 2 of Item 302 "Aggregates for Surface Treatments." Ensure aggregate bed is in place and at least 9 inches deep, prior to setting the ground box. Install ground box on top of aggregate.
2. Cast ground box aprons in place. Reinforcing steel may be field bent. Ensure the depth of concrete for the apron extends from finished grade to the top of the aggregate bed under the box. Ground box aprons, including concrete and reinforcing steel, are subsidiary to ground boxes when called for by descriptive code.
3. Keep bolt holes in the box clear of dirt. Bolt covers down when not working in ground boxes.
4. Install all conduits and ells in a neat and workmanlike manner. Uniformly space conduits so grounding bushings and bell end fittings can easily be installed.
5. Temporarily seal all conduits in the ground box until conductors are installed.
6. Permanently seal conduits immediately after the completion of conductor installation and pull tests. Permanently seal the ends of all conduits with duct seal, expandable foam, or other method as approved. Do not use duct tape as a permanent conduit sealant. Do not use silicone caulk as a sealant.
7. When a ground rod is present in a ground box, bond all equipment grounding conductors together and to the ground rod with listed connectors.
8. When a type B or D ground box is stacked to meet volume requirements, it is allowable to cut an appropriately sized hole for conduit entry in the side wall at least 18 inches below grade.
9. If an existing ground box in the contract has a metal cover, bond the cover to the equipment grounding conductor with a 3 ft. long stranded bonding jumper the same size as the grounding conductor. The bonding jumper is subsidiary to various bid items. Verify existing ground boxes with metal covers are shown on the plans, with notes fully describing the work required.
10. If other ground boxes with metal covers are within the project limits but are not part of the contract, the Engineer may direct the Contractor to bond the metal covers, identifying the specific boxes in writing. This work will be paid for separately.
11. Bond metal ground box covers to the grounding conductor with a tank ground type lug.

DATE:
FILE:

				Traffic Operations Division Standard	
<h2>ELECTRICAL DETAILS GROUND BOXES</h2>					
<h3>ED(4) - 14</h3>					
FILE: ed4-14.dgn	DN: TxDOT	CK: TxDOT	DW: TxDOT	CK: TxDOT	
© TxDOT October 2014	CONT	SECT	JOB	HIGHWAY	
REVISIONS	0910	16	165	MLK JR	
	DIST	COUNTY		SHEET NO.	
	TYLER	SMITH		41	

ELECTRICAL SERVICES NOTES

- Provide new materials. Ensure installation and materials comply with the applicable provisions of the National Electrical Code (NEC) and National Electrical Manufacturers Association (NEMA) standards. Ensure material is Underwriters Laboratories (UL) listed. Provide and install electrical service conduits, conductors, disconnects, contactors, circuit breaker panels, and branch circuit breakers as shown on the Electrical Service Data chart in the plans. Faulty fabrication or poor workmanship in material, equipment, or installation is justification for rejection. Where manufacturers provide warranties and guarantees as a customary trade practice, furnish these to the State.
- Provide electrical services in accordance with Electrical Details standard sheets, Departmental Material Specification (DMS) 11080 "Electrical Services," DMS 11081 "Electrical Services-Type A," DMS 11082 "Electrical Services-Type C," DMS 11083 "Electrical Services-Type D," DMS 11084 "Electrical Services-Type T," DMS 11085 "Electrical Services-Pedestal (PS)", and Item 628 "Electrical Services" of the Standard Specifications. Provide electrical service types A, C, and D, as listed on the Material Producers List (MPL) on the Department web site under "Roadway Illumination and Electrical Supplies," Item 628. Provide other service types as detailed on the plans.
- Provide all work, materials, services, and any incidentals needed to install a complete electrical service as specified in the plans.
- Coordinate with the Engineer and the utility provider for metering and compliance with utility requirements. Primary line extensions, connection charges, meter charges, and other charges by the utility company to provide power to the location are paid for in accordance with Item 628. Get approval for the costs associated with these charges prior to engaging the utility company to do the work. Consult with the utility provider to determine costs and requirements, and coordinate the work as approved.
- The enclosure manufacturer will provide Master Lock Type 2 with brass tumblers keyed #2195 for all custom electrical enclosures. Installing Contractor is to provide Master Lock #2195 Type 2 with brass tumblers for "off the shelf" enclosures. Master Lock #2195 keys and locks become property of the State. Unless otherwise approved, do not energize electrical service equipment until locks are installed.
- Enclosures with external disconnects that de-energize all equipment inside the enclosure do not need a dead front trim. Protect incoming line terminations from incidental contact as required by the NEC.
- When galvanized is specified for nuts, screws, bolts or miscellaneous hardware, stainless steel may be used.
- Provide wiring and electrical components rated for 75°C. Provide red, black, and white colored XHHW service entrance conductors of minimum size 6 American Wire Gauge (AWG). Identify size 6 AWG conductors by continuous color jacket. Identify electrical conductors sized 4 AWG and larger by continuous color jacket or by colored tape. Mark at least 6 inches of the conductor's insulation with half laps of colored tape, when identifying conductors. Ensure each service entrance conductor exits through a separately bushed non-metallic opening in the weatherhead. The lengths of the conductors outside the weatherhead are to be 12 inches minimum, 18 inches maximum, or as required by utility.
- All electrical service conduit and conductors attached to the electrical service including the riser or the elbow below ground are subsidiary to the electrical service. For an underground utility feed, all service conduit and conductors after the elbow, including service conduit and conductors for the utility pole riser when furnished by the Contractor, will be paid for separately.
- Provide rigid metal conduit (RMC) for all conduits on service, except for the 1/2 in. PVC conduit containing the electrical service grounding electrode conductor. Size the service entrance conduit as shown in the plans. Ensure conduit for branch circuit entry to enclosure is the same size as that shown on the layout sheets for branch circuit conduit. Extend all rigid metal conduits a minimum of 6 inches underground and then couple to the type and schedule of the conduit shown on the layout for that particular branch circuit. Install a grounding bushing on the RMC where it terminates in the service enclosure.
- Use of liquidtight flexible metal conduit (LFMC) is allowed between the meter and service enclosure when they are mounted 90 to 180 degrees to each other. Size the LFMC the same size as service entrance conduit. LFMC must not exceed 3 feet in length. Strap LFMC within 1 foot of each end. LFMC less than 12 inches in length need not be strapped. Each end of LFMC must have a grounding bushing or be terminated with a grounding fitting. The LFMC must contain a grounded (neutral) conductor. Ensure any bend in LFMC never exceeds 180 degrees. A pull test is required on all installed conductors, with at least six inches of free conductor movement demonstrated to the satisfaction of the Engineer.
- Ensure all mounting hardware and installation details of services conform to utility company specifications.
- For all electrical service enclosures listed under Item 628 on the MPL, the UL 508 enclosure manufacturers will prepare and submit a schematic drawing unique to each service. Before shipment to the job site, place the applicable laminated schematic drawings and the laminated plan sheet showing the electrical service data chart used to build the enclosure in the enclosure's data pocket. The installing contractor will copy and laminate the actual project plan sheets detailing all equipment and branch circuits supplied by that service. The laminated plan sheets are to be placed in the service enclosure's document pocket. Reduce 11 in. x 17 in. plan sheets to 8 1/2 in. x 11 in. before laminating. If the installation differs from the plan sheets, the installing contractor is to redline plan sheets before laminating.
- When providing an "Off The Shelf" Type D or Type T service, provide laminated plan sheets detailing equipment and branch circuits supplied by that service. Reduce 11 in. x 17 in. plan sheets to 8 1/2 in. x 11 in before laminating. Deliver these drawings before completion of the work to the Engineer, instead of placing in enclosure that has no door pocket.
- Do not install conduit in the back wall of a service enclosure where it would penetrate the equipment mounting panel inside the enclosure. Provide grounding bushings on all metal conduits, and terminate bonding jumpers to grounding bus. Grounding bushings are not required when the end of the metal conduit is fitted with a conduit sealing hub or threaded boss, such as a meter base hub.

SERVICE ASSEMBLY ENCLOSURE

- Provide threaded hub for all conduit entries into the top of enclosure.
- Type galvanized steel (GS) enclosures may be used for Type C panelboards and for Type D and T services that do not use an enclosure mounted photocell or lighting contactor. Provide GS enclosures in accordance with DMS 11080, 11082, 11083, and 11084.
- Provide aluminum (AL) and stainless steel (SS) enclosures for Types A, C, and D in accordance with DMS 11080, 11081, 11082, 11083, and 11084. Do not paint stainless steel.
- Provide pedestal service (PS) enclosures in accordance with ED(9) and DMS 11080 and 11085. Do not provide GS pedestal services. If GS is shown in the PS descriptive code, provide an AL enclosure.

MAIN DISCONNECT & BRANCH CIRCUIT BREAKERS

- Field drill flange-mounted remote operator handle if needed, to ensure handle is lockable in both the "On" and "Off" positions.
- When the utility company provides a transformer larger than 50 KVA, verify that the available fault current is less than the circuit breaker's ampere interrupting capacity (AIC) rating and provide documentation from the electric utility provider to the Engineer.

PHOTOELECTRIC CONTROL

- Provide photocell as listed on the MPL. Move, adjust, or shield the photocell from stray or ambient night time light to ensure proper operation. Mount photocell facing north when practical. Mount top of pole photocells as shown on Top Mounted Photocell Detail.

* ELECTRICAL SERVICE DATA												
Elec. Service ID	Plan Sheet Number	Electrical Service Description	Service Conduit *xS Size	Service Conductors No./Size	Safety Switch Amps	Main Ckt. Bkr. Pole/Amps	Two-Pole Contractor Amps	Panelbd/ Loadcenter Amp Rating	Branch Circuit ID	Branch Ckt. Bkr. Pole/Amps	Branch Circuit Amps	KVA Load
SB 183	289	ELC SRV TY A 240/480 100(SS)AL(E)SF(U)	2"	3/#2	100	2P/100	100	N/A	Lighting NB	2P/40	26	28.1
									Lighting SB	2P/40	25	
									Underpass	1P/20	15	
NB Access	30	ELC SRV TY D 120/240 060(NS)SS(E)TS(O)	1 1/4"	3/#6	N/A	2P/60		100	Sig. Controller	1P/30	23	5.3
							30		Luminaires	2P/20	9	
									CCTV	1P/20	3	
2nd & Main	58	ELC SRV TY T 120/240 000(NS)GS(N)SP(O)	1 1/4"	3/#6	N/A	N/A	N/A	70	Flashing Beacon 1	1P/20	4	1.0
									Flashing Beacon 2	1P/20	4	

* Example only, not for construction. All new electrical services must have electrical service data chart specific to that service as shown in the plans.

** Verify service conduit size with utility. Size may change due to utility meter requirements. Ensure conduit size meets the National Electrical Code.

EXPLANATION OF ELECTRICAL SERVICE DESCRIPTIVE CODE

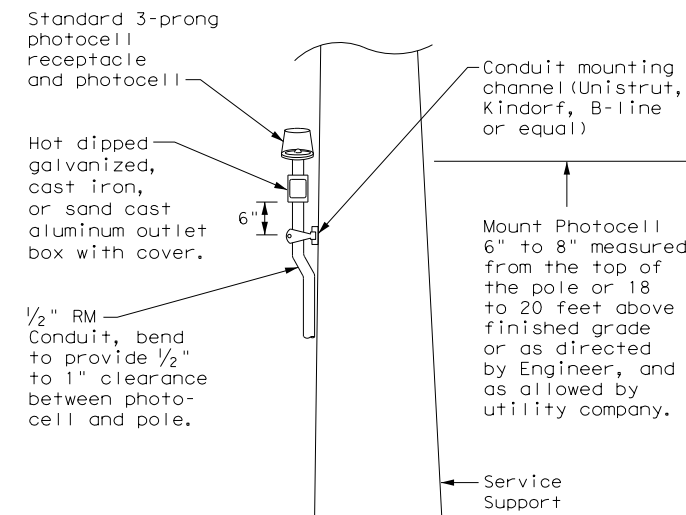
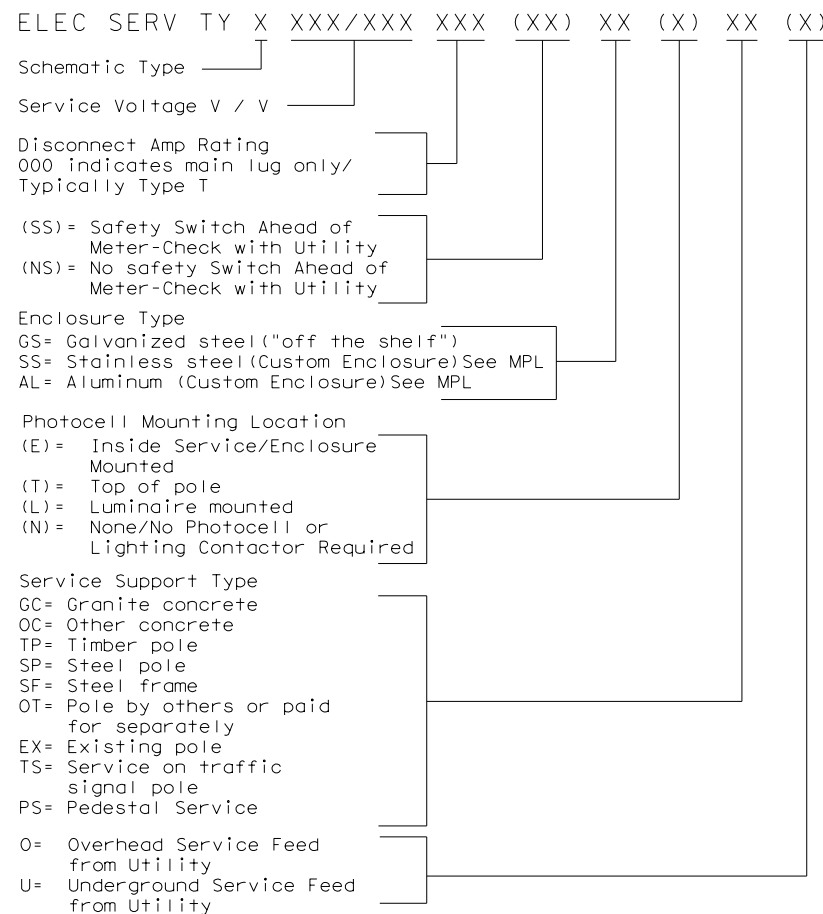

TOP MOUNTED PHOTOCELL

Install conduit strap maximum 3 feet from box. 5 foot maximum spacing between straps supporting conduit.

Texas Department of Transportation Traffic Operations Division Standard

ELECTRICAL DETAILS SERVICE NOTES & DATA

ED(5) - 14

FILE: ed5-14.dgn	DN: TxDOT	CK: TxDOT	DW: TxDOT	CK: TxDOT
© TxDOT October 2014	CONT	SECT	JOB	HIGHWAY
REVISIONS	0910	16	165	MLK JR
	DIST	COUNTY	SHEET NO.	
	TYLER	SMITH	42	

DISCLAIMER: The use of this standard is governed by the "Texas Engineering Practice Act". No warranty of any kind is made by TxDOT for any purpose whatsoever. TxDOT assumes no responsibility for the conversion of this standard to other formats or for incorrect results or damages resulting from its use.

DATE: FILE:

DISCLAIMER: The use of this standard is governed by the "Texas Engineering Practice Act". No warranty of any kind is made by TxDOT for any purpose whatsoever. TxDOT assumes no responsibility for the conversion of this standard to other formats or for incorrect results or damages resulting from its use.

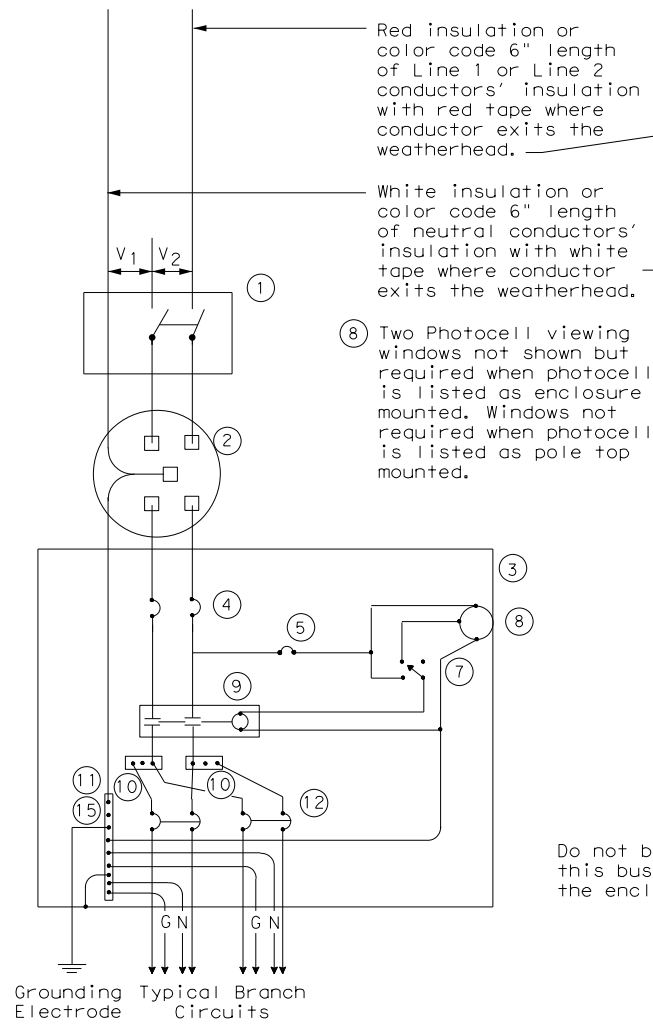

SCHEMATIC TYPE A
THREE WIRE

WIRING LEGEND	
—	Power Wiring
—	Control Wiring
—N—	Neutral Conductor
—G—	Equipment grounding conductor-always required

Red insulation or color code 6" length of Line 1 or Line 2 conductors' insulation with red tape where conductor exits the weatherhead.

White insulation or color code 6" length of neutral conductors' insulation with white tape where conductor exits the weatherhead.

⑧ Two Photocell viewing windows not shown but required when photocell is listed as enclosure mounted. Windows not required when photocell is listed as pole top mounted.

Do not bond this bus to the enclosure

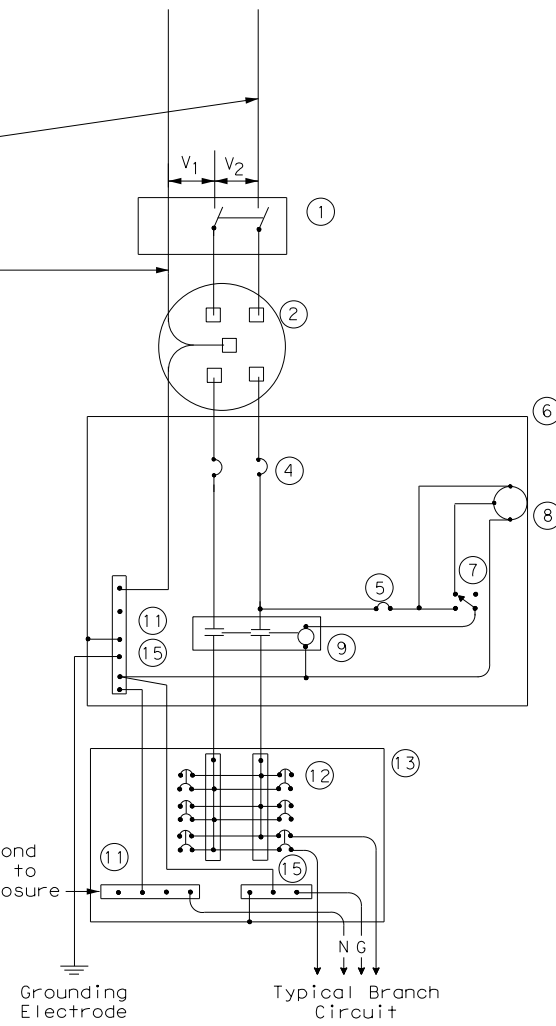

SCHEMATIC TYPE C
THREE WIRE

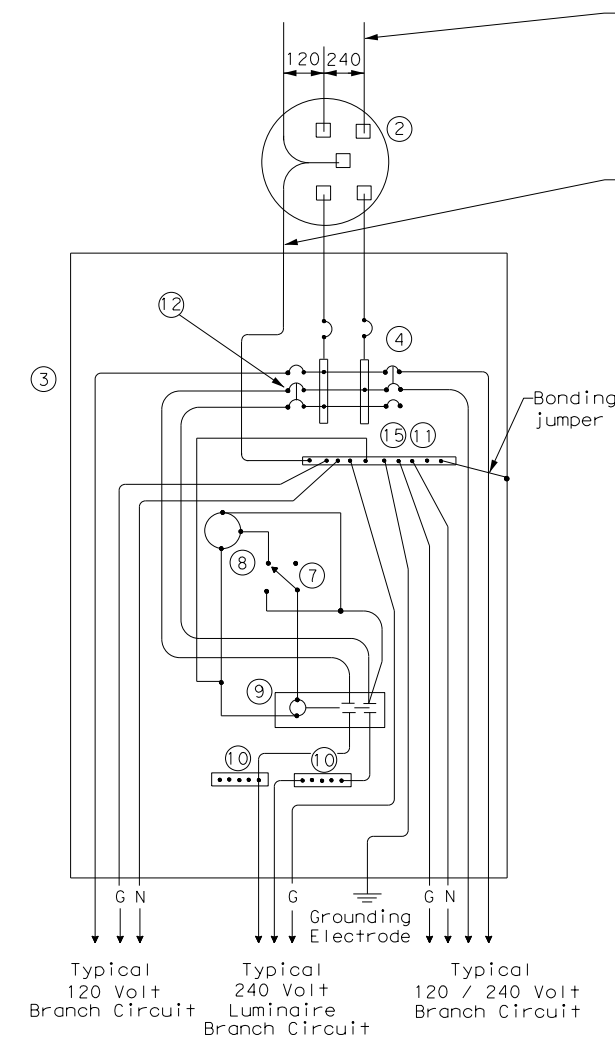

SCHEMATIC TYPE D - CUSTOM
120/240 VOLTS - THREE WIRE

Red insulation or color code 6" length of Line 1 or Line 2 conductors' insulation with red tape where conductor exits the weatherhead.

White insulation or color code 6" length of neutral conductors' insulation with white tape where conductor exits the weatherhead.

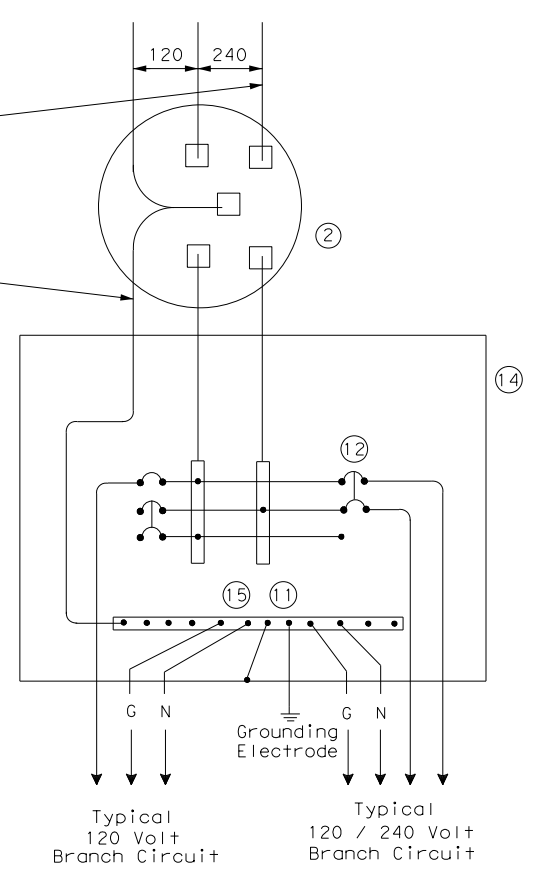

SCHEMATIC TYPE T
120/240 VOLTS - THREE WIRE
Galvanized steel-"Buy Off The Shelf" only. When required install photocell top of the pole or on luminaire only, no lighting contractor will be installed.

SCHEMATIC LEGEND	
1	Safety Switch (when required)
2	Meter (when required-verify with electric utility provider)
3	Service Assembly Enclosure
4	Main Disconnect Breaker (See Electrical Service Data)
5	Circuit Breaker, 15 Amp (Control Circuit)
6	Auxiliary Enclosure
7	Control Station ("H-O-A" Switch)
8	Photo Electric Control (enclosure-mounted shown)
9	Lighting Contactor
10	Power Distribution Terminal Blocks
11	Neutral Bus
12	Branch Circuit Breaker (See Electrical Service Data)
13	Separate Circuit Breaker Panelboard
14	Load Center
15	Ground Bus

				Traffic Operations Division Standard	
ELECTRICAL DETAILS SERVICE ENCLOSURE AND NOTES					
ED(6) - 14					
FILE: ed6-14.dgn	DN: TxDOT	CK: TxDOT	DW: TxDOT	CK: TxDOT	
© TxDOT October 2014	CONT	SECT	JOB	HIGHWAY	
REVISIONS	0910	16	165	MLK JR	
	DIST	COUNTY	SHEET NO.		
	TYLER	SMITH	43		

TRAFFIC SIGNAL NOTES

1. Do not pass luminaire conductors through the signal controller cabinet.
2. Include an equipment grounding conductor in all conduits throughout the electrical system. Bond all exposed metal parts to the grounding conductor.
3. Provide roadway luminaires, when required, in accordance with the material and construction sections of Item 610, "Roadway Illumination Assemblies," except for performance testing of luminaires. Test installed roadway luminaires for proper operation as a part of the associated traffic signal system test.
4. If internally illuminated street name signs are approved for use, ground the fixture to the pole with a 12 AWG green XHHW conductor.
5. Bond anchor bolts to rebar cage in two locations using #3 bars or 6 AWG stranded copper conductors. Use listed mechanical connectors rated for embedment in concrete. See TXDOT standard TS-FD for further details.
6. Drill and tap signal poles for 1/2 in. X 13 UNC tank ground fitting. Provide and install tank ground fitting 4 in. to 6 in. directly below electrical service enclosure. Provide properly sized hole through the bottom of the enclosure for the service grounding electrode conductor. Connect the electrical service grounding electrode conductor to the tank ground fitting. Ensure electrical service grounding electrode conductor is as short and straight as possible from the enclosure to the tank ground fitting. See Inset A detail for further information. Size service entrance conduit and branch circuit conduit as shown in the plans.
7. Mount electrical service enclosure and meter to signal pole with stainless steel bands. Ensure bands are a minimum width of 3/4 in. Secure enclosures to bands using two-bolt brackets. Install brackets near top and bottom of each enclosure. Install properly sized stainless steel washers on each bolt in the enclosure. Band or drill and tap properly sized stand-off straps to signal pole for attaching conduit.
8. Conduct pull tests and insulation resistance tests on all illumination and power conductors as required in Item 620 "Electrical Conductors" and ED(3). To prevent electronics damage, do not conduct insulation resistance tests on traffic signal cables after termination.
9. Lock all enclosures and bolt down all ground box covers before applying power to the signal installation.
10. Terminate conduits entering the top of enclosures with a conduit-sealing hub or threaded boss such as meter hub. Install a grounding bushing on all metal conduits not connected to conduit-sealing hub or threaded boss. Bond the grounding bushing to the ground bus with a bonding jumper. Seal all conduits entering enclosures with duct seal or expanding foam. Do not use silicone to seal conduit ends.
11. For all conduits, ensure the burial depth is a minimum of 18". Ensure the minimum burial depth for conduit placed under a roadway is 24".

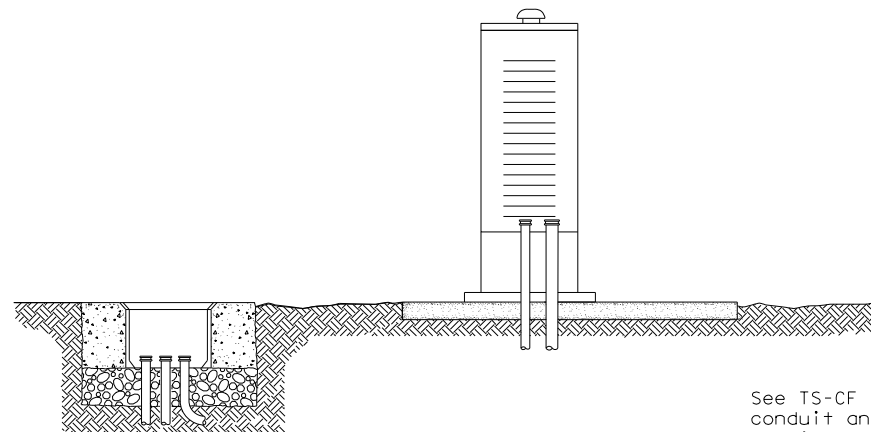
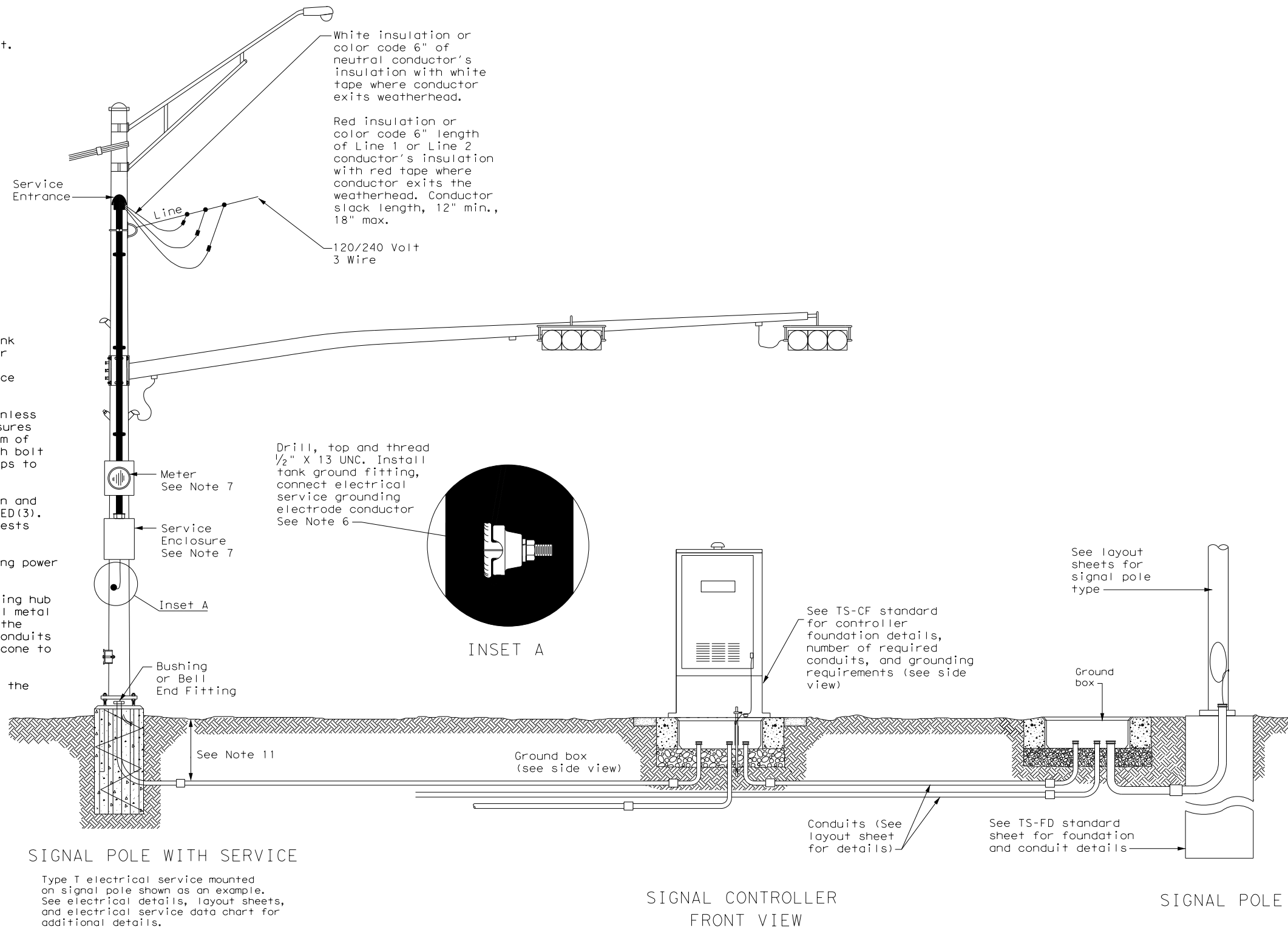

SIGNAL CONTROLLER SIDE VIEW

See TS-CF standard for conduit and grounding requirements. See layout sheets for ground box locations and any additional conduits that are required.

DISCLAIMER: The use of this standard is governed by the "Texas Engineering Practice Act". No warranty of any kind is made by TXDOT for any purpose whatsoever. TXDOT assumes no responsibility for the conversion of this standard to other formats or for incorrect results or damages resulting from its use.

DATE: FILE:

ELECTRICAL DETAILS TYPICAL TRAFFIC SIGNAL SYSTEM DETAILS ED(8) - 14

FILE: ed8-14.dgn	DN: TxDOT	CK: TxDOT	DW: TxDOT	CK: TxDOT
© TXDOT October 2014	CONT	SECT	JOB	HIGHWAY
REVISIONS	0910	16	165	MLK JR
	DIST	COUNTY	SHEET NO.	
	TYLER	SMITH	44	

DISCLAIMER: The use of this standard is governed by the "Texas Engineering Practice Act". No warranty of any kind is made by TxDOT for any purpose whatsoever. TxDOT assumes no responsibility for the conversion of this standard to other formats or for incorrect results or damages resulting from its use.

PEDESTAL SERVICE NOTES

1. Manufacture pedestal electrical services in accordance with Departmental Material Specifications (DMS)11080 "Electrical Services", 11085 "Electrical Services-Pedestal (PS)" and Item 628 "Electrical Services." Provide pedestal electrical services as listed on the Material Producers List (MPL) on the Department's web site under "Roadway Illumination and Electrical Supplies," Item 628. Ensure all mounting hardware and installation details of services meet utility company specifications. Contact the local utility company for approval of pedestal details prior to installing the electrical pedestal service. Submit any changes required by the utility company prior to manufacturing the pedestal enclosure.
2. When a meter socket is required, provide a socket with a minimum 100 amp rating that complies with local utility requirements.
3. Provide Class A or C concrete for pedestal service foundations in accordance with Item 420, "Concrete Substructures," except that concrete will not be paid for directly but is considered subsidiary to Item 628.
4. Provide #4 reinforcing steel for foundations in accordance with Item 440, "Reinforcement for Concrete."
5. Install 1/2 in. X 2 1/16 in. minimum length concrete single expansion type anchors for mounting pedestal enclosure to foundation. Anchor location to match mounting holes in each corner of enclosure. Secure each of the four corners of the pedestal enclosure to the anchors in the foundation with a 1/2 in. galvanized or stainless steel machine thread bolt, a properly sized locknut and a flat washer.
6. Finish top of concrete foundation in a neat and workmanlike manner. If leveling washers are used, ensure no more than 1/8 in. gap at any corner. Do not exceed a maximum dip or rise in the foundation of 1/8 in. per foot. When properly installed, ensure the top of the service enclosure is level front to back and side to side within 1/4 in. Repair rocking or movement of the service enclosure at no additional cost to the department.
7. Do not use liquidtight flexible metal conduit (LFMC) on pedestal type services.
8. Ensure all elbows in the foundation are sized as per utility provider's conduit requirements for underground conduit and feeders. PVC extensions may be installed provided the ends of the rigid metal conduits are more than 2 in. below the top of the concrete foundation. Where extension conduits are metal, grounding bushings must be installed with a bonding jumper properly terminated.

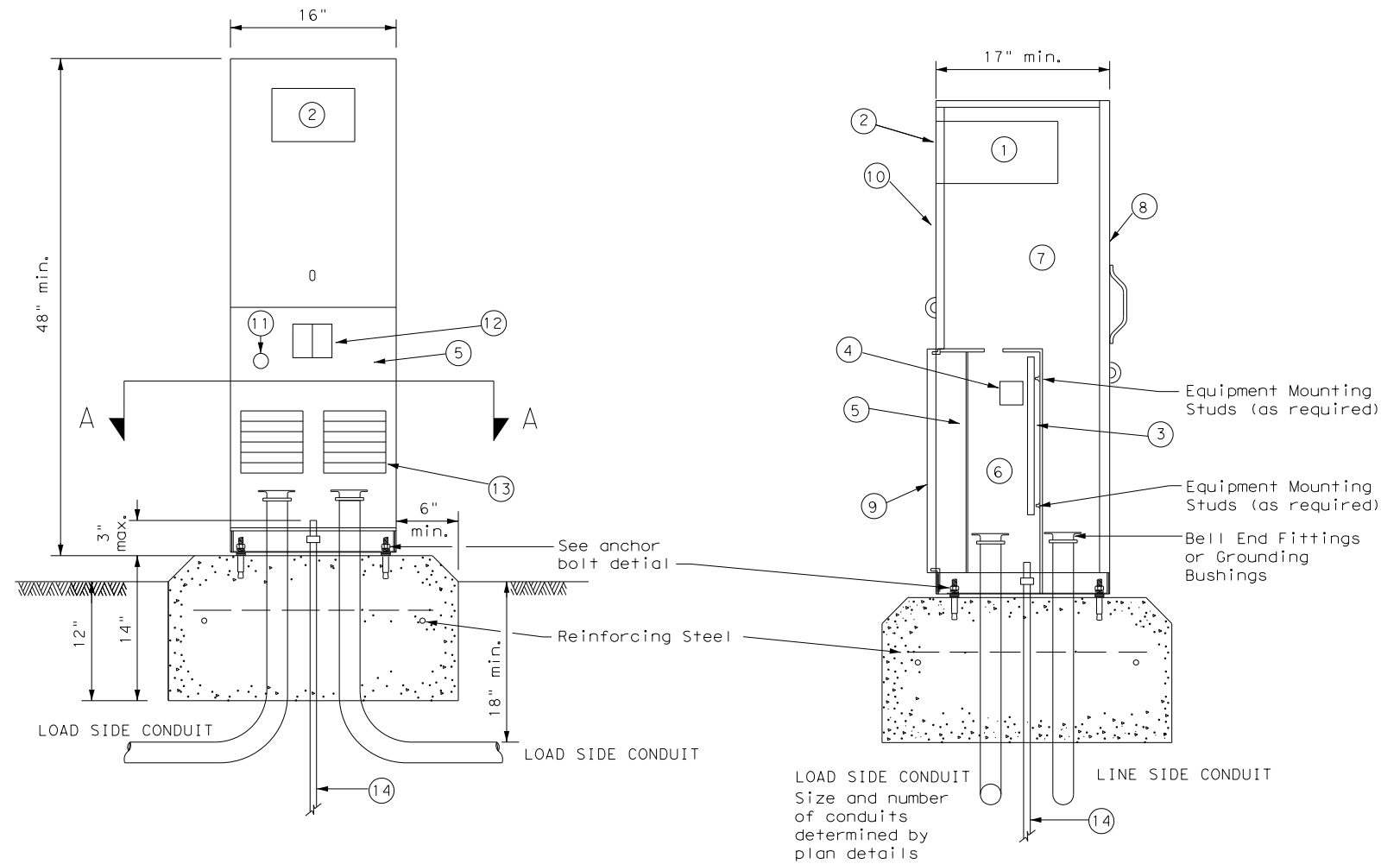

FRONT VIEW

SIDE VIEW

TYPE C shown, TYPE A similar except that TYPE A shall have individual circuit breakers (CB) mounted on an equipment mounting panel. CB Handles shall protrude through hinged deadfront trim.

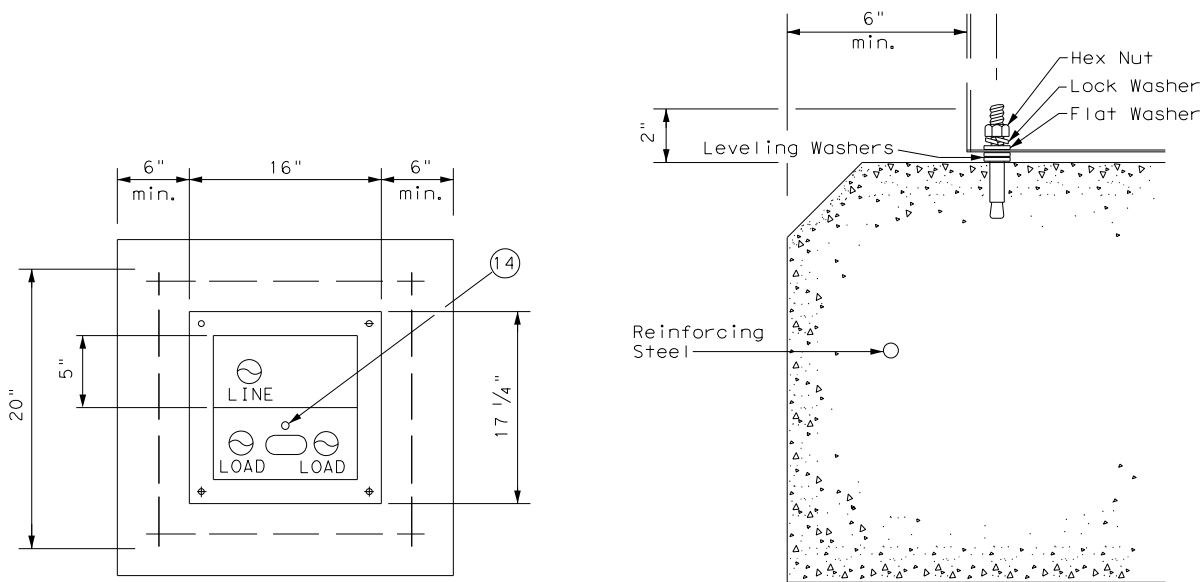

SECTION A-A

ANCHOR BOLT DETAIL

LEGEND

1	Meter Socket, (when required)
2	Meter Socket Window, (when required)
3	Equipment Mounting Panel
4	Photo Electric Control Window, (When required)
5	Hinged Deadfront Trim
6	Load Side Conduit Trim
7	Line Side Conduit Area
8	Utility Access Door, with handle
9	Pedestal Door
10	Hinged Meter Access
11	Control Station (H-O-A Switch)
12	Main Disconnect
13	Branch Circuit Breakers
14	Copper Clad Ground Rod - 5/8" X 10'



ELECTRICAL DETAILS
ELECTRICAL SERVICE SUPPORT
PEDESTAL SERVICE TYPE PS

ED(9) - 14

FILE:	ed9-14.dgn	DN:	TxDOT	CK:	TxDOT	DW:	TxDOT	CK:	TxDOT
© TxDOT	October 2014	CONT	SECT	JOB	HIGHWAY				
REVISIONS		0910	16	165	MLK JR				
		DIST	COUNTY	SHEET NO.					
		TYLER	SMITH	45					

DATE:
FILE:

REFLECTIVE RAISED PAVEMENT MARKERS FOR VEHICLE POSITIONING GUIDANCE

DISCLAIMER: The use of this standard is governed by the "Texas Engineering Practice Act". No warranty of any kind is made by TxDOT for any purpose whatsoever. TxDOT assumes no responsibility for the conversion of this standard to other formats or for incorrect results or damages resulting from its use.

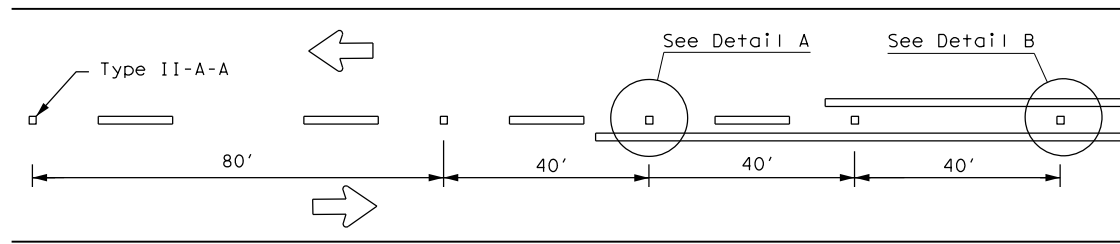

CENTERLINE FOR ALL TWO LANE ROADWAYS

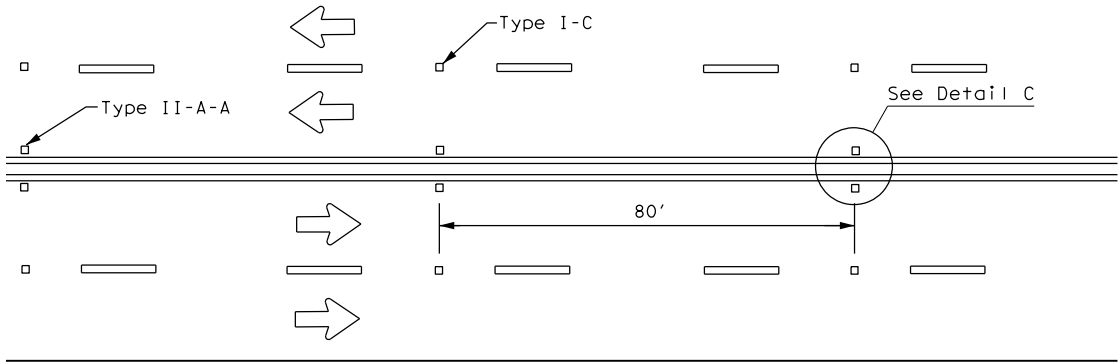

CENTERLINE & LANE LINES
FOR FOUR LANE TWO-WAY HIGHWAYS

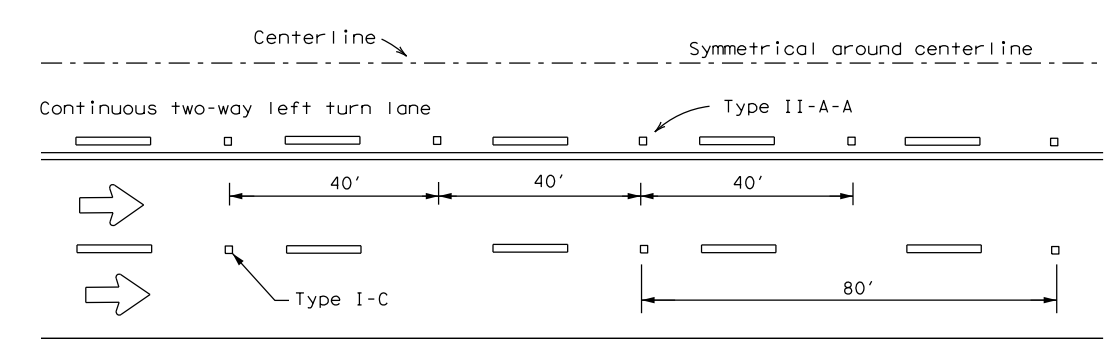
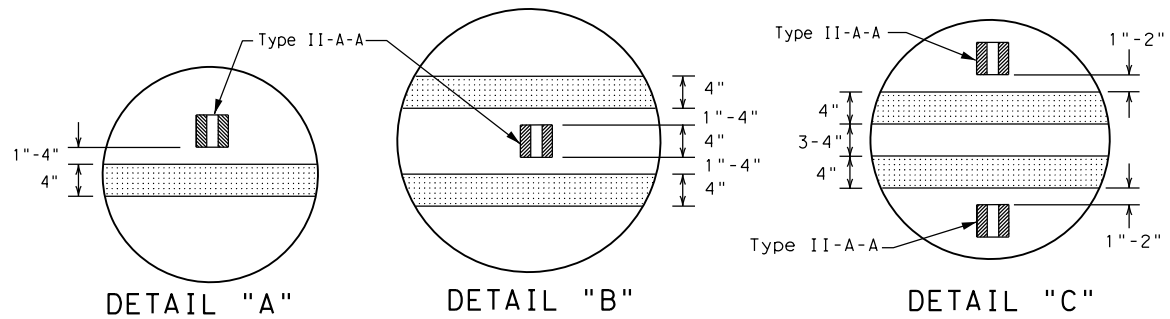

CENTERLINE AND LANE LINES FOR TWO-WAY LEFT TURN LANE

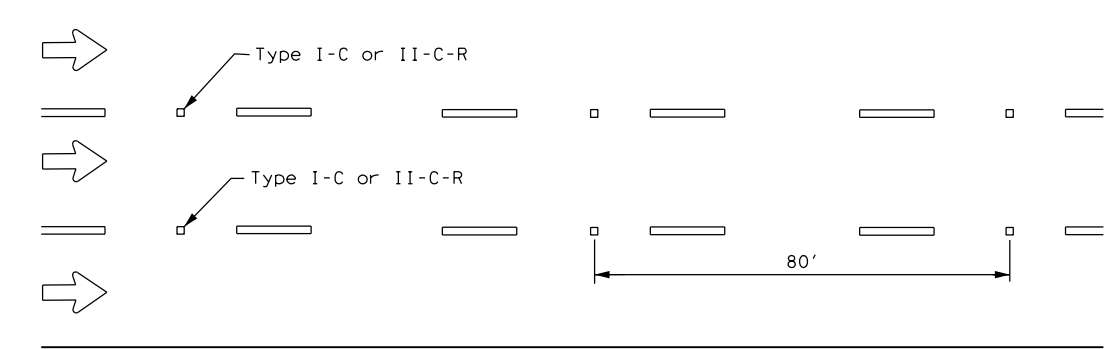

LANE LINES FOR ONE-WAY ROADWAY (NON-FREEWAY FACILITIES)

Raised pavement markers Type II-C-R shall have clear face toward normal traffic and red face toward wrong-way traffic.

MATERIAL SPECIFICATIONS	
PAVEMENT MARKERS (REFLECTORIZED)	DMS-4200
EPOXY AND ADHESIVES	DMS-6100
BITUMINOUS ADHESIVE FOR PAVEMENT MARKERS	DMS-6130
TRAFFIC PAINT	DMS-8200
HOT APPLIED THERMOPLASTIC	DMS-8220
PERMANENT PREFABRICATED PAVEMENT MARKINGS	DMS-8240

All pavement marking materials shall meet the required Departmental Material Specifications as specified by the plans.

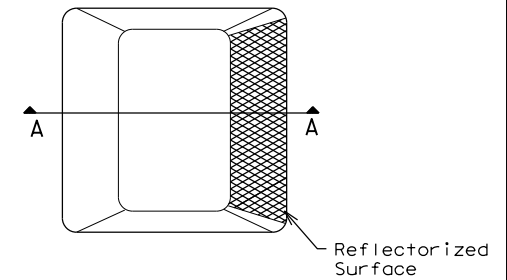

Type I (Top View)

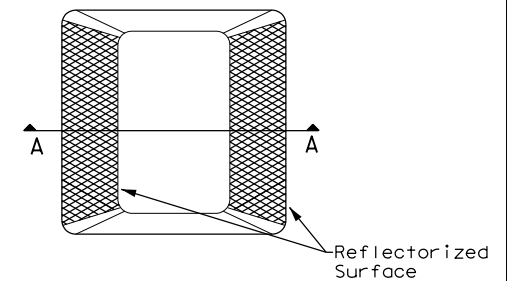

Type II (Top View)

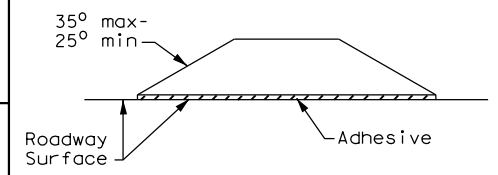

SECTION A

RAISED PAVEMENT MARKERS

GENERAL NOTES

- All raised pavement markers placed in broken lines shall be placed in line with and midway between the stripes.
- On concrete pavements the raised pavement markers should be placed to one side of the longitudinal joints.

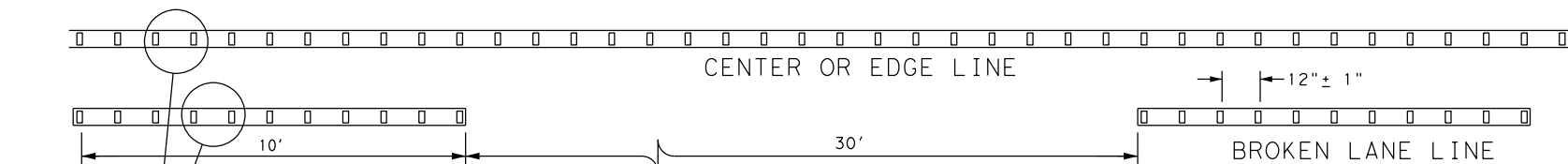

REFLECTORIZED PROFILE PATTERN DETAIL

USING REFLECTIVE PROFILE PAVEMENT MARKINGS

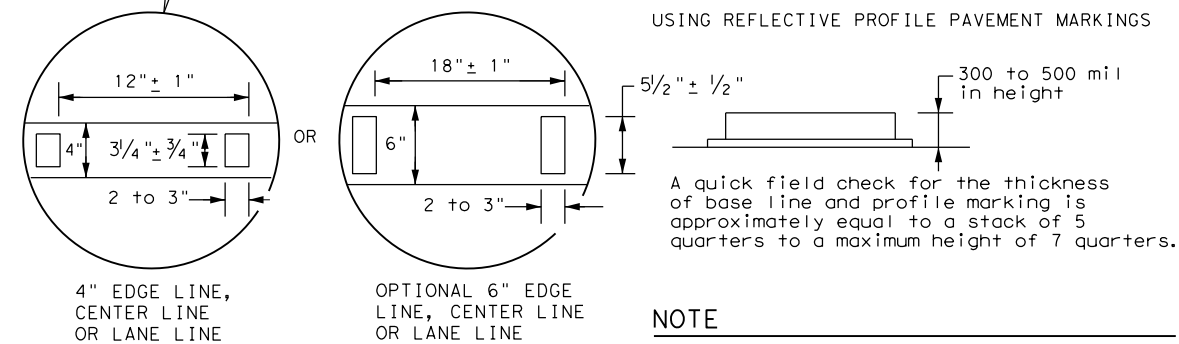

NOTE

Profile markings shall not be placed on roadways with a posted speed limit of 45 MPH or less.



POSITION GUIDANCE USING RAISED MARKERS REFLECTORIZED PROFILE MARKINGS PM(2) - 20

FILE: pm2-20.dgn	DN:	CK:	DW:	CK:
© TxDOT April 1977	CONT	SECT	JOB	HIGHWAY
4-92 2-10 REVISIONS	0910	16	165	MLK JR
5-00 2-12	DIST	COUNTY	SHEET NO.	
8-00 6-20	TYLER	SMITH	47	

DATE: DATE TIME
FILE: DOCUMENT NAME

DISCLAIMER: The use of this standard is governed by the "Texas Engineering Practice Act". No warranty of any kind is made by TxDOT for any purpose whatsoever. TxDOT assumes no responsibility for the conversion of this standard to other formats or for incorrect results or damages resulting from its use.

DATE: DATE TIME
FILE: DOCUMENT NAME

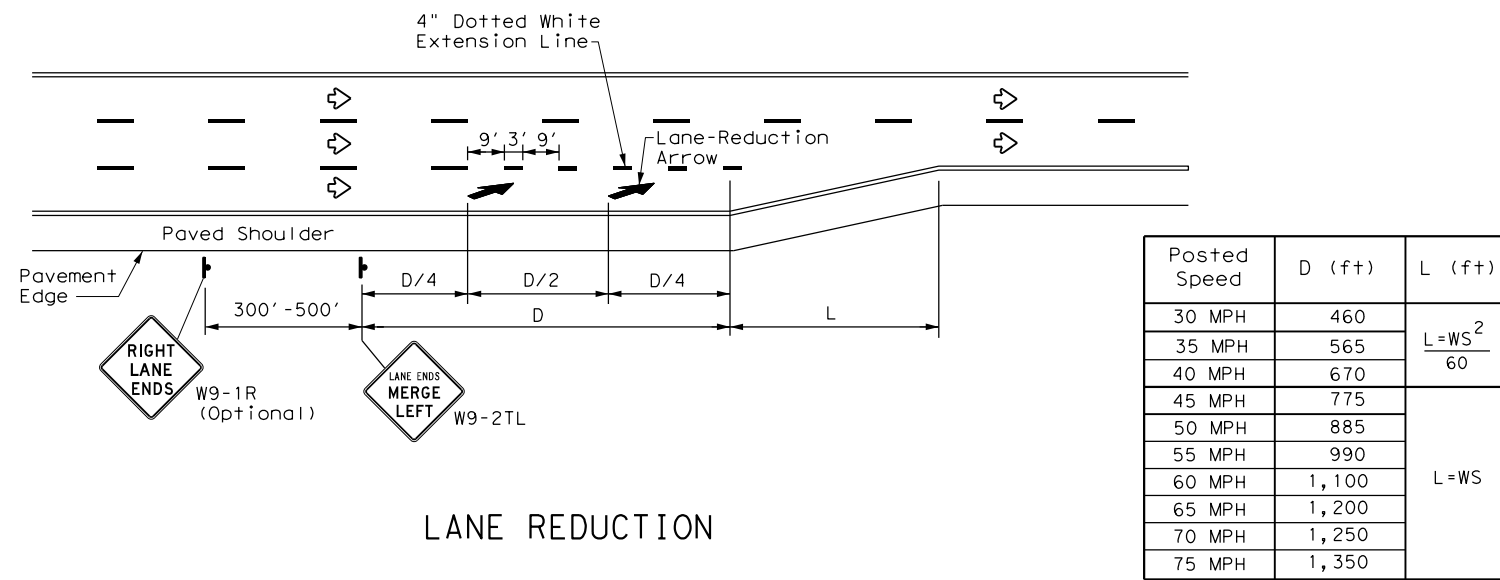

Posted Speed	D (ft)	L (ft)
30 MPH	460	$L = \frac{WS^2}{60}$
35 MPH	565	
40 MPH	670	L = WS
45 MPH	775	
50 MPH	885	
55 MPH	990	
60 MPH	1,100	
65 MPH	1,200	
70 MPH	1,250	
75 MPH	1,350	

LANE REDUCTION

NOTES

- Lane reduction pavement markings are used where the number of through lanes is reduced because of narrowing of the roadway or because of a section of on-street parking in what would otherwise be a through lane. For Texas Super 2 Passing Lanes, see TS2(PL) standard sheets.
- On divided highways, an additional W9-1R "RIGHT LANE ENDS" sign may be installed in the median aligned with the W9-1R sign on the right side of the highway.
- Lane reduction arrows are required for speeds of 45 mph or greater. An optional third lane reduction arrow may be added based on engineering judgement. If used, the optional third lane reduction arrow should be centered between the first and last lane reduction arrows.
- For lane reductions on Freeways and Expressways, signing shall conform to the TxDOT Freeway Signing Handbook.

GENERAL NOTES

- Lane use word and arrow markings shall be used where through lanes approaching an intersection become mandatory turn lanes. Lane use word and arrow markings should be used in auxiliary lanes of substantial length. Lane use arrow markings or word and arrow markings may be used in other lanes and turn bays for emphasis. Details for words and arrows are as shown in the Standard Highway Sign Designs for Texas.
- When lane-use words and arrow markings are used, two sets of arrows should be used if the length of the bay is greater than 180 feet. When a single lane use arrow or word and arrow marking is used for a short turn lane, it should be located at or near the upstream end of the full-width turn lane.
- Use raised pavement marker Type I-C with undivided highways, flush medians and two way left turn lanes. Use raised pavement marker Type II-C-R with divided highways and raised medians.
- Length of turn bays, including taper, deceleration, and storage lengths shall be as shown on the plans or as directed by the Engineer.

MATERIAL SPECIFICATIONS	
PAVEMENT MARKERS (REFLECTORIZED)	DMS-4200
EPOXY AND ADHESIVES	DMS-6100
BITUMINOUS ADHESIVE FOR PAVEMENT MARKERS	DMS-6130
TRAFFIC PAINT	DMS-8200
HOT APPLIED THERMOPLASTIC	DMS-8220
PERMANENT PREFABRICATED PAVEMENT MARKINGS	DMS-8240

All pavement marking materials shall meet the required Departmental Material Specifications as specified by the plans.

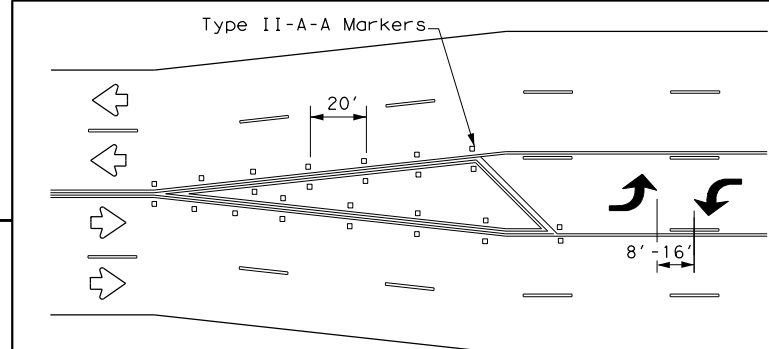

A two-way left-turn (TWLTL) lane-use arrow pavement marking should be used at or just downstream from the beginning of a two-way left-turn lane within a corridor. Repeating the marking after each intersection or dedicated turn bay is not required unless stated elsewhere in the plans.

TYPICAL TRANSITION FOR TWLTL AND DIVIDED HIGHWAY

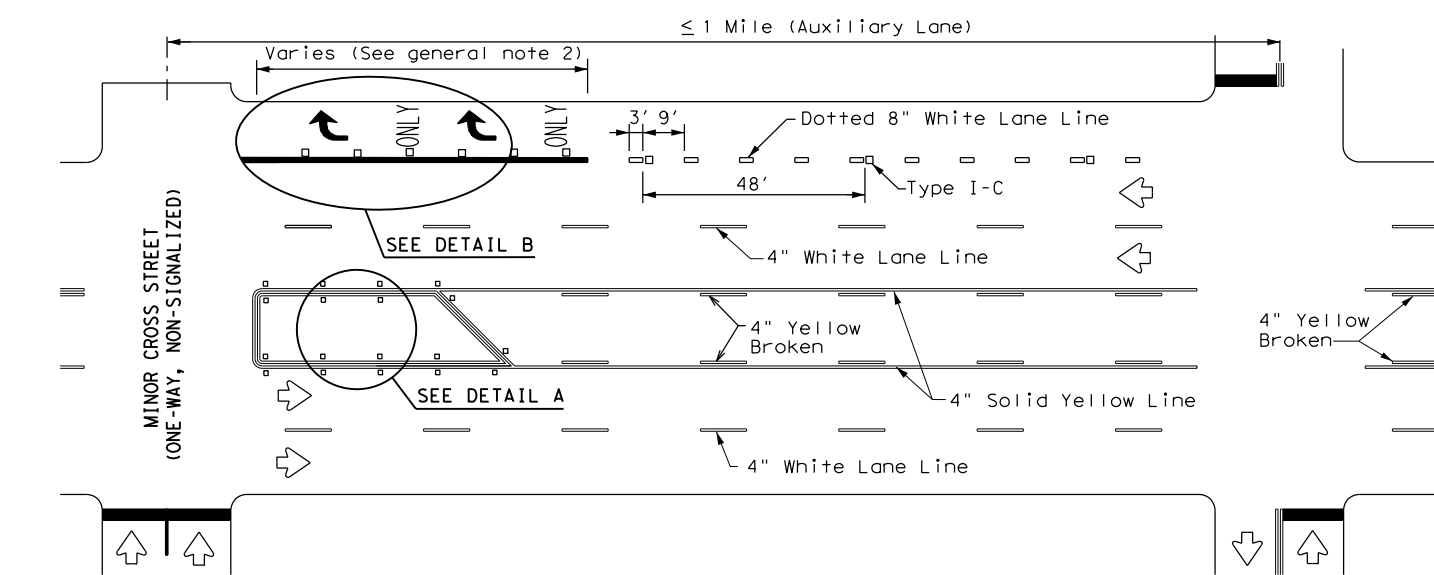

TYPICAL TWLTL AT ONE-WAY STREET AND RIGHT TURN AUXILIARY LANE

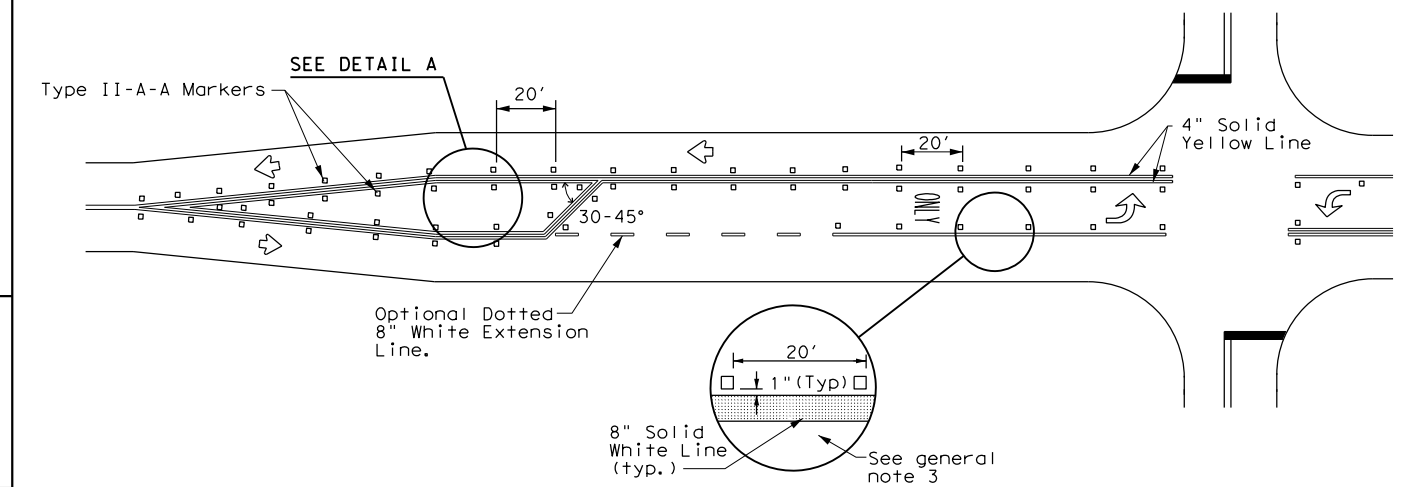

TYPICAL TWO-LANE HIGHWAY INTERSECTION WITH LEFT TURN BAYS

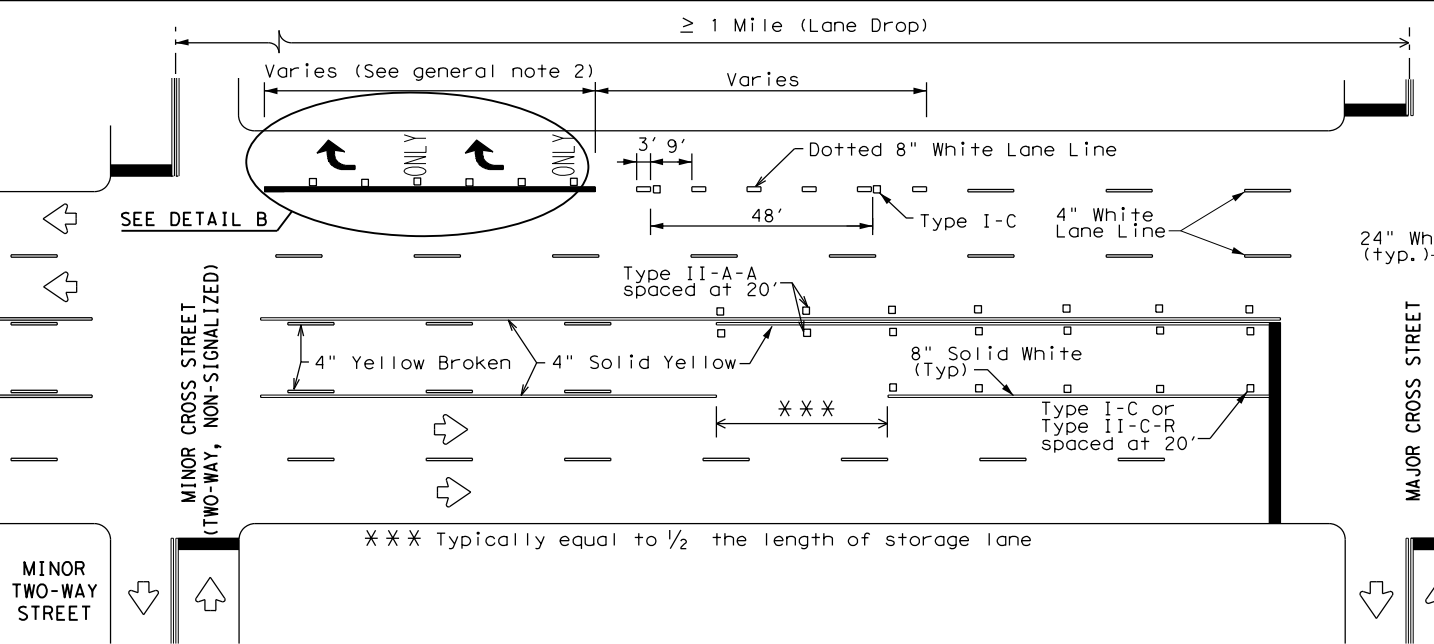

TYPICAL TWLTL AT TWO-WAY CROSS STREET AND RIGHT TURN LANE DROP

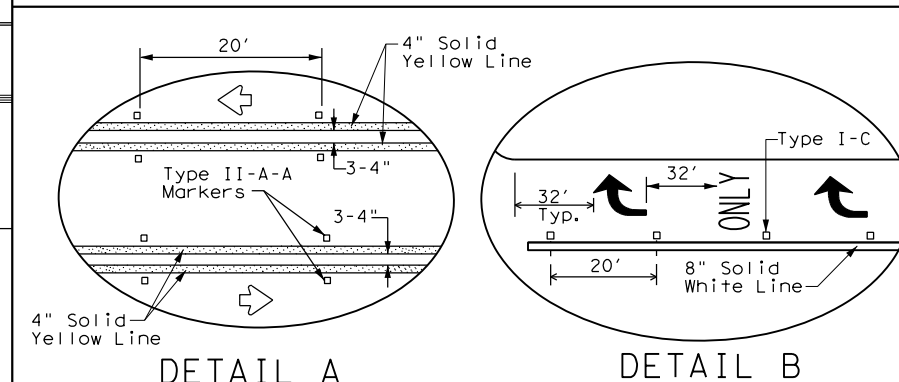

DETAIL A

DETAIL B

Texas Department of Transportation
Traffic Safety Division Standard

TWO-WAY LEFT TURN LANES, RURAL LEFT TURN BAYS, AND LANE REDUCTION PAVEMENT MARKINGS PM(3)-20

FILE: pm3-20.dgn	DN:	CK:	DW:	CK:
© TxDOT April 1998	CON:	SECT:	JOB:	HIGHWAY:
REVISIONS	0910	16	165	MLK JR
5-00 2-10	DIST:	COUNTY:	SHEET NO.	
8-00 2-12	TYLER	SMITH	48	
3-03 6-20				

22C

DISCLAIMER: The use of this standard is governed by the "Texas Engineering Practice Act". No warranty of any kind is made by TxDOT for any purpose whatsoever. TxDOT assumes no responsibility for the conversion of this standard to other formats or for incorrect results or damages resulting from its use.

DATE: DATE TIME
FILE: DOCUMENT NAME

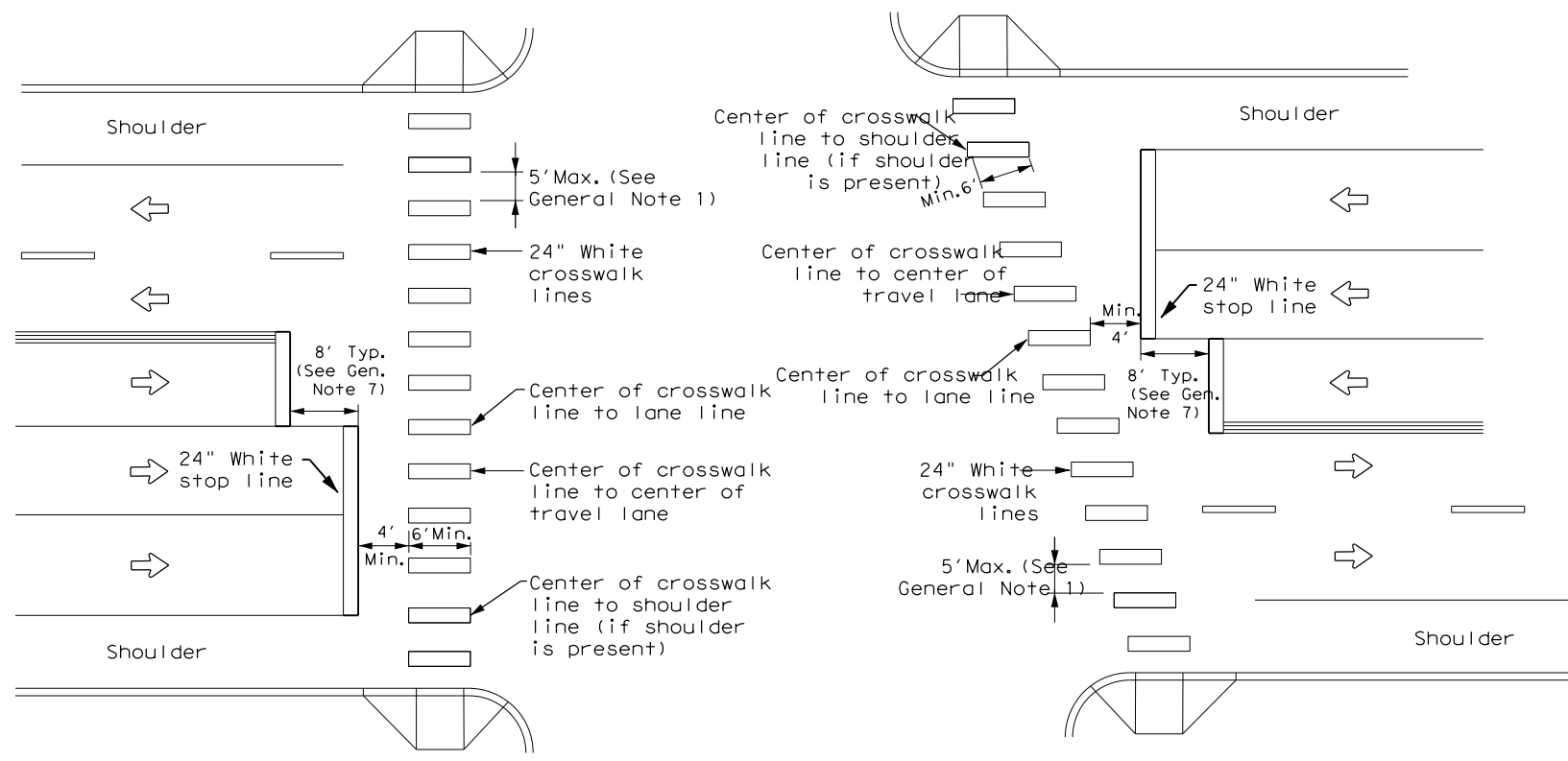

HIGH-VISIBILITY LONGITUDINAL CROSSWALK AT CONTROLLED APPROACH

GENERAL NOTES

1. Longitudinal crosswalk lines should not be placed in the wheel path of vehicles. Center the crosswalk lines on travel lanes, lane lines, and shoulder lines (if present).
2. A minimum 6" clear distance shall be provided to the curb face. If the last crosswalk line falls into this distance it must be omitted.
3. For divided roadways, adjustments in spacing of the crosswalk lines should be made in the median so that the crosswalk lines are maintained in their proper location across the travel portion of the roadway.
4. At skewed crosswalks, the crosswalk lines are to remain parallel to the lane lines.
5. Each crosswalk shall be a minimum of 6' wide.
6. The High-Visibility Longitudinal Crosswalk is the preferred crosswalk pattern on State Highways. Other crosswalk patterns as shown in the "Texas Manual on Uniform Traffic Control Devices" may be used. All crosswalk designs and dimension shall comply with the "Texas Manual on Uniform Traffic Control Devices."
7. Final placement of Stop Bar and Crosswalk shall be approved by the Engineer in the field.

MATERIAL SPECIFICATIONS

PAVEMENT MARKERS (REFLECTORIZED)	DMS-4200
EPOXY AND ADHESIVES	DMS-6100
BITUMINOUS ADHESIVE FOR PAVEMENT MARKERS	DMS-6130
TRAFFIC PAINT	DMS-8200
HOT APPLIED THERMOPLASTIC	DMS-8220
PERMANENT PREFABRICATED PAVEMENT MARKINGS	DMS-8240

All pavement marking materials shall meet the required Departmental Material Specifications as specified by the plans.

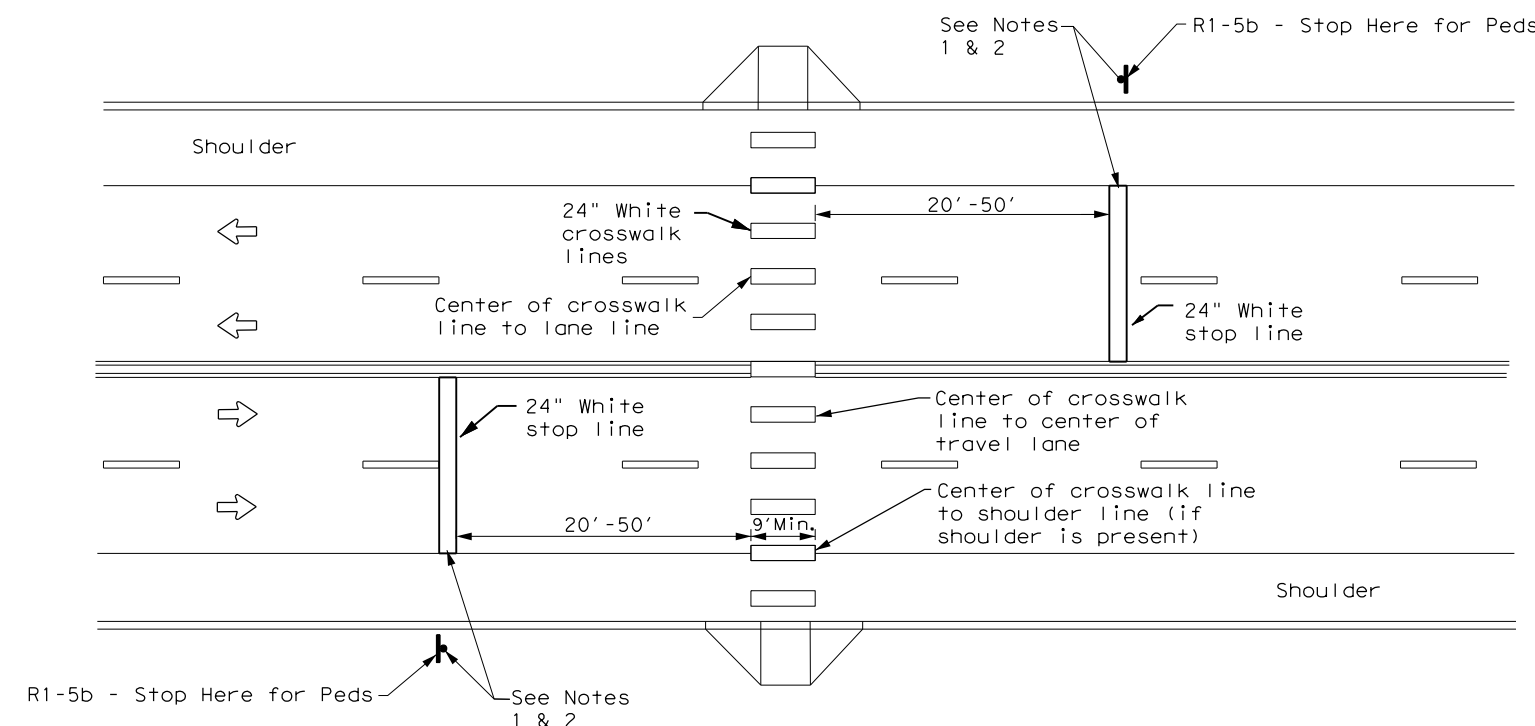

UNSIGNALIZED MID BLOCK HIGH-VISIBILITY LONGITUDINAL CROSSWALK

NOTES:

1. Use stop bars with "Stop Here for Pedestrians" signs at unsignalized mid block crosswalks.
2. Use stop bars with "Stop Here on Red" signs at mid block crosswalks controlled by traffic signals or pedestrian hybrid beacons.

CROSSWALK WIDTH = 9' FOR APPROACH SPEEDS OF 30 MPH OR LESS
CROSSWALK WIDTH = 12' FOR APPROACH SPEEDS OF 35 MPH OR MORE



04/12/2022
THE AFFIXED SEAL ABOVE APPLIES ONLY TO INFORMATION FILLED BY ABOVE STATED ENGINEER.



CROSSWALK PAVEMENT MARKINGS

PM(4)-22 (MOD)

FILE: pm4-22.dgn	DN:	CK:	DW:	CK:
© TxDOT June 2020	CONT	SECT	JOB	HIGHWAY
3-22 REVISIONS	0190	16	165	MLK JR
	DIST	COUNTY	SHEET NO.	
	TYL	SMITH	49	

DISCLAIMER: The use of this standard is governed by the "Texas Engineering Practice Act". No warranty of any kind is made by TxDOT for any purpose whatsoever. TxDOT assumes no responsibility for the conversion of this standard to other formats or for incorrect results or damages resulting from its use.

SIGN SUPPORT DESCRIPTIVE CODES

(Descriptive Codes correspond to project estimate and quantities sheets)

SM RD SGN ASSM TY XXXXX (X) XX (X-XXXX)

Post Type

FRP = Fiberglass Reinforced Plastic Pipe (see SMD(FRP))
 TWT = Thin-Walled Tubing (see SMD(TWT))
 10BWG = 10 BWG Tubing (see SMD(SLIP-1) to (SLIP-3))
 S80 = Schedule 80 Pipe (see SMD(SLIP-1) to (SLIP-3))

Number of Posts (1 or 2)

Anchor Type

UA = Universal Anchor - Concreted (see SMD(FRP) and (TWT))
 UB = Universal Anchor - Bolted down (see SMD(FRP) and (TWT))
 WS = Wedge Anchor Steel - (see SMD(TWT))
 WP = Wedge Anchor Plastic (see SMD(TWT))
 SA = Slipbase - Concreted (see SMD(SLIP-1) to (SLIP-3))
 SB = Slipbase - Bolted Down (see SMD(SLIP-1) to (SLIP-3))

Sign Mounting Designation

P = Prefab. "Plain" (see SMD(SLIP-1) to (SLIP-3), (TWT), (FRP))
 T = Prefab. "T" (see SMD(SLIP-1) to (SLIP-3), (TWT))
 U = Prefab. "U" (see SMD(SLIP-1) to (SLIP-3))
 IF REQUIRED
 1EXT or 2EXT = Number of Extensions (see SMD(SLIP-1) to (SLIP-3), (TWT))
 BM = Extruded Wind Beam (see SMD(SLIP-1) to (SLIP-3))
 WC = 1.12 #/ft Wing Channel (see SMD(SLIP-1) to (SLIP-3))
 EXAL = Extruded Aluminum Sign Panels (see SMD(SLIP-3))

REQUIRED CLEARANCE FOR BREAKAWAY SUPPORT

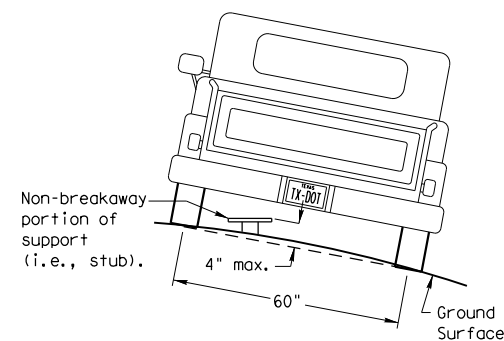

To avoid vehicle undercarriage snagging, any substantial remains of a breakaway support, when it is broken away, should not project more than 4 inches above a 60-inch chord (i.e., typical space between wheel paths).

SIGN LOCATION

PAVED SHOULDERS

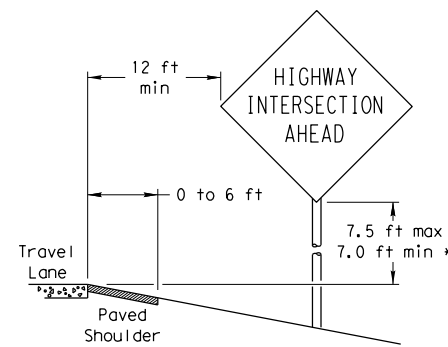

LESS THAN 6 FT. WIDE

When the shoulder is 6 ft. or less in width, the sign must be placed at least 12 ft. from the edge of the travel lane.

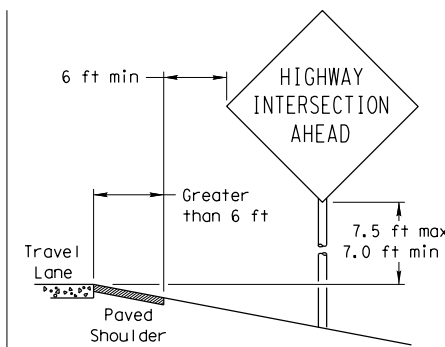

GREATER THAN 6 FT. WIDE

When the shoulder is greater than 6 ft in width, the sign must be placed at least 6 ft. from the edge of the shoulder.

T-INTERSECTION

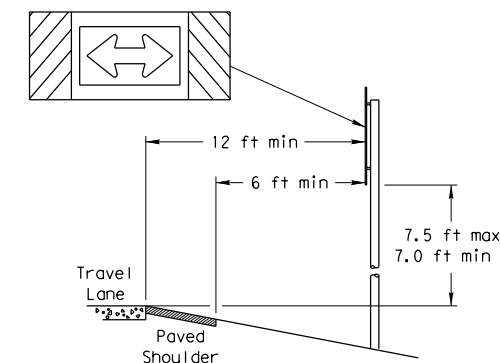

When this sign is needed at the end of a two-lane, two way roadway, the right edge of the sign should be in line with the centerline of the roadway. Place as close to ROW as practical.

No more than 2 sign posts should be located within a 7 ft. circle.

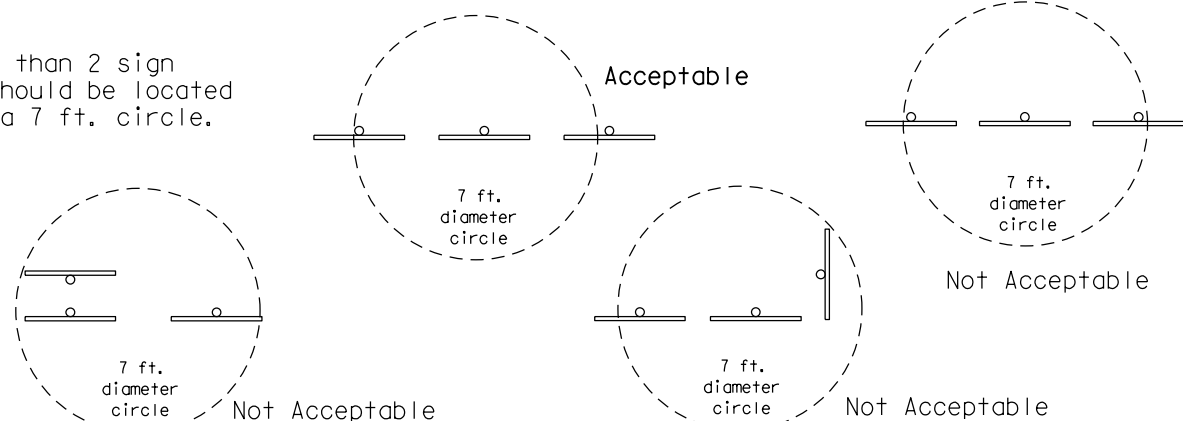

BEHIND BARRIER

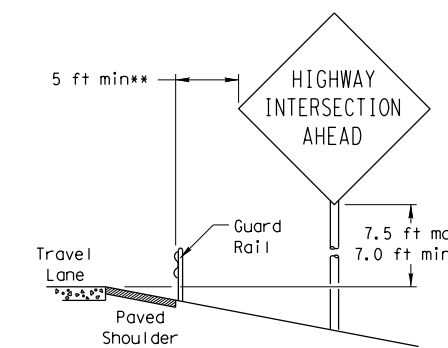

BEHIND GUARDRAIL

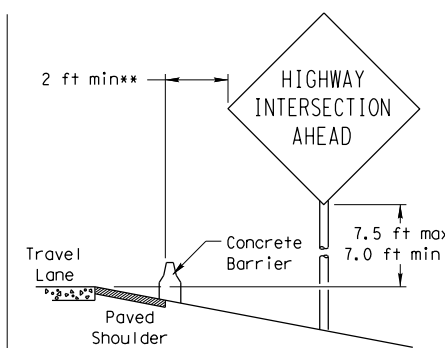

BEHIND CONCRETE BARRIER

**Sign clearance based on distance required for proper guard rail or concrete barrier performance.

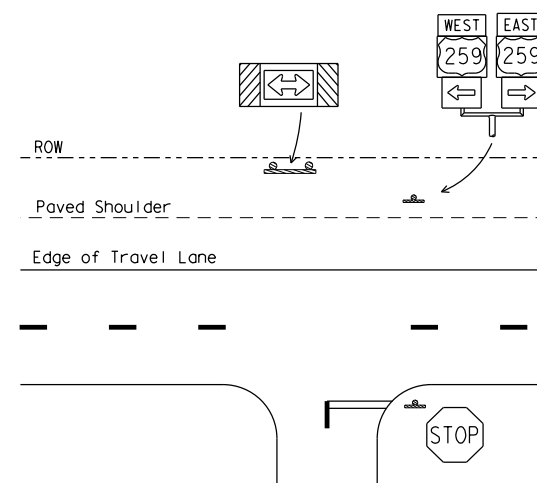

* Signs shall be mounted using the following condition that results in the greatest sign elevation:

- (1) a minimum of 7 to a maximum of 7.5 feet above the edge of the travel lane or
- (2) a minimum of 7 to a maximum of 7.5 feet above the grade at the base of the support when sign is installed on the backslope.

The maximum values may be increased when directed by the Engineer.

See the Traffic Operations Division website for detailed drawings of sign clamps, Triangular Slipbase System components and Wedge Anchor System components.

The website address is:
<http://www.txdot.gov/publications/traffic.htm>

TYPICAL SIGN ATTACHMENT DETAIL

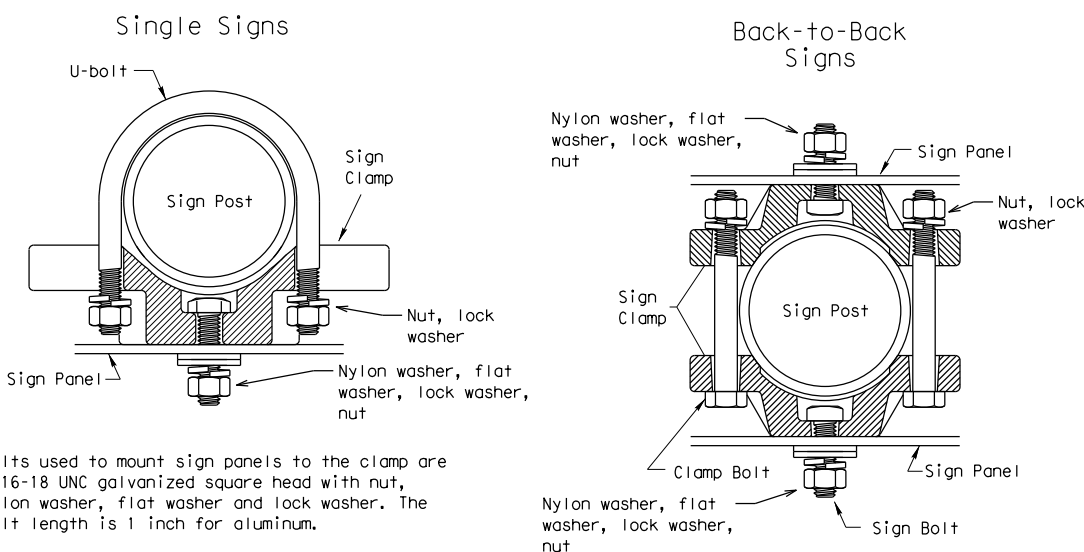

Bolts used to mount sign panels to the clamp are 5/16-18 UNC galvanized square head with nut, nylon washer, flat washer and lock washer. The bolt length is 1 inch for aluminum.

When two sign clamps are used to mount signs back-to-back, use a 5/16-18 UNC galvanized hex head per ASTM A307 with nut and helical-spring lock washer. The approximate bolt lengths for various post sizes and sign clamp types are given in the table at right. The bolt length may need to be adjusted depending upon field conditions.

Sign clamps may be either the specific size clamp or the universal clamp.

Pipe Diameter	Approximate Bolt Length	
	Specific Clamp	Universal Clamp
2" nominal	3"	3 or 3 1/2"
2 1/2" nominal	3 or 3 1/2"	3 1/2 or 4"
3" nominal	3 1/2 or 4"	4 1/2"

SIGNS WITH PLAQUES

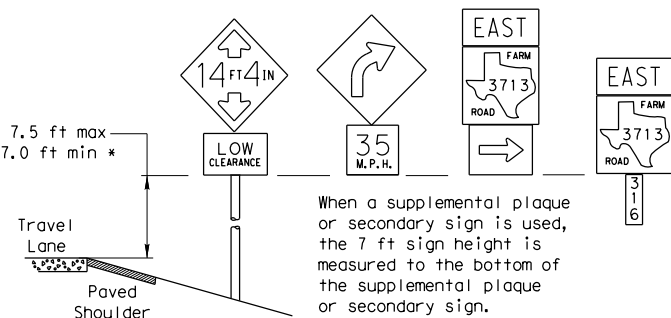

When a supplemental plaque or secondary sign is used, the 7 ft sign height is measured to the bottom of the supplemental plaque or secondary sign.

CURB & GUTTER OR RAISED ISLAND

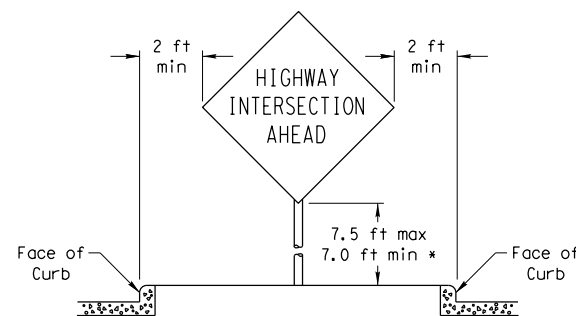

RESTRICTED RIGHT-OF-WAY (When 6 ft min. is not possible.)

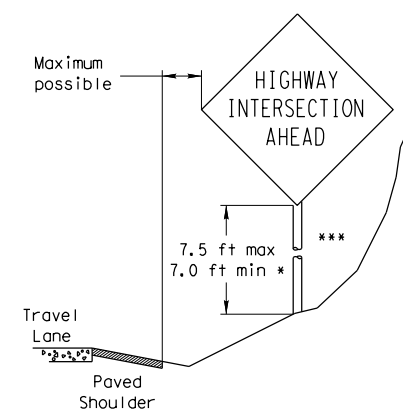

Right-of-way restrictions may be created by rocks, water, vegetation, forest, buildings, a narrow island, or other factors.

In situations where a lateral restriction prevents the minimum horizontal clearance from the edge of the travel lane, signs should be placed as far from the travel lane as practical.

*** Post may be shorter if protected by guardrail or if Engineer determines the post could not be hit due to extreme slope.



SIGN MOUNTING DETAILS SMALL ROADSIDE SIGNS GENERAL NOTES & DETAILS

SMD(GEN)-08

© TxDOT July 2002		DN: TXDOT	CK: TXBOT	DW: TXBOT	CK: TXBOT
9-08	REVISIONS	CONT	SECT	JOB	HIGHWAY
		0910	16	165	MLK JR
		DIST	COUNTY		SHEET NO.
		TYLER	SMITH		50

DISCLAIMER: The use of this standard is governed by the "Texas Engineering Practice Act". No warranty of any kind is made by TxDOT for any purpose whatsoever. TxDOT assumes no responsibility for the conversion of this standard to other formats or for incorrect results or damages resulting from its use.

TRIANGULAR SLIPBASE INSTALLATION GENERAL REQUIREMENTS

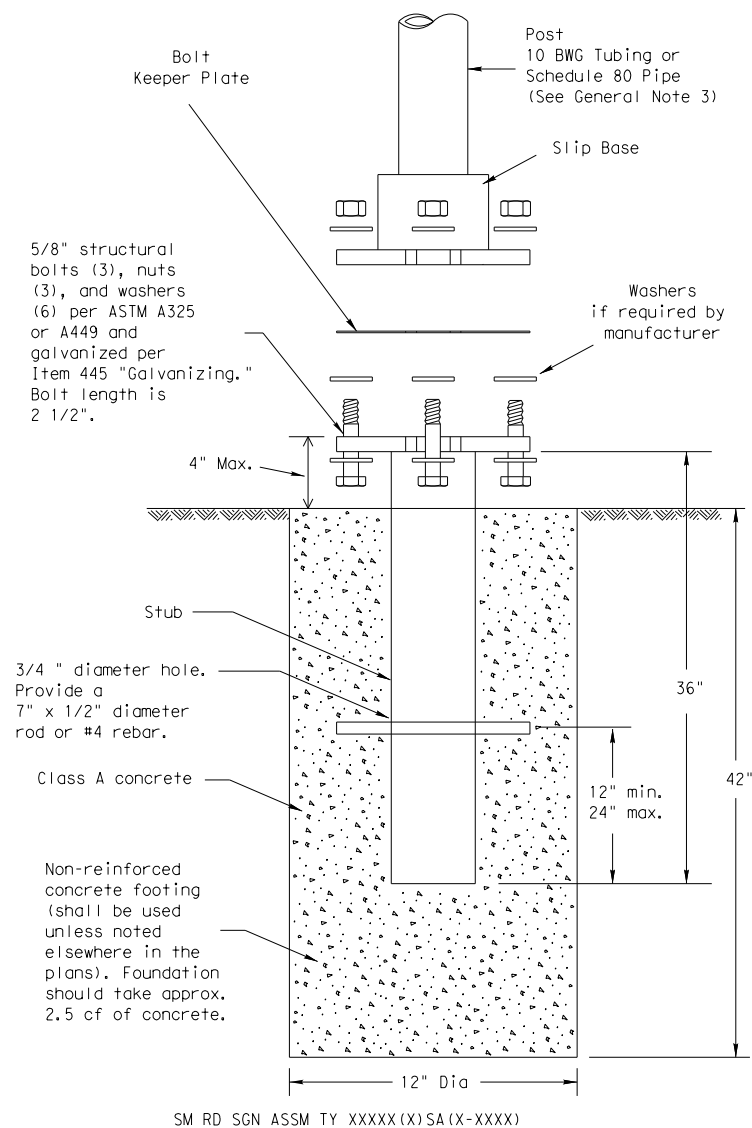

NOTE

There are various devices approved for the Triangular Slipbase System. Please reference the Material Producer List for approved slip base systems. http://www.txdot.gov/business/producer_list.htm The devices shall be installed per manufacturers' recommendations. Installation procedures shall be provided to the Engineer by Contractor.

GENERAL NOTES:

- Slip base shall be permanently marked to indicate manufacturer. Method, design, and location of marking are subject to approval of the TxDOT Traffic Standards Engineer.
- Material used as post with this system shall conform to the following specifications:
 - 10 BWG Tubing (2.875" outside diameter)
 - 0.134" nominal wall thickness
 - Seamless or electric-resistance welded steel tubing or pipe
 - Steel shall be HSLAS Gr 55 per ASTM A1011 or ASTM A1008
 - Other steels may be used if they meet the following:
 - 55,000 PSI minimum yield strength
 - 70,000 PSI minimum tensile strength
 - 20% minimum elongation in 2"
 - Wall thickness (uncoated) shall be within the range of 0.122" to 0.138"
 - Outside diameter (uncoated) shall be within the range of 2.867" to 2.883"
 - Galvanization per ASTM A123 or ASTM A653 G210. For precoated steel tubing (ASTM A653), recoat tube outside diameter weld seam by metallizing with zinc wire per ASTM B833.
 - Schedule 80 Pipe (2.875" outside diameter)
 - 0.276" nominal wall thickness
 - Steel tubing per ASTM A500 Gr C
 - Other seamless or electric-resistance welded steel tubing or pipe with equivalent outside diameter and wall thickness may be used if they meet the following:
 - 46,000 PSI minimum yield strength
 - 62,000 PSI minimum tensile strength
 - 21% minimum elongation in 2"
 - Wall thickness (uncoated) shall be within the range of 0.248" to 0.304"
 - Outside diameter (uncoated) shall be within the range of 2.855" to 2.895"
 - Galvanization per ASTM A123
- See the Traffic Operations Division website for detailed drawings of sign clamps and Texas Universal Triangular Slipbase System components. The website address is: <http://www.txdot.gov/publications/traffic.htm>
- Sign supports shall not be spliced except where shown. Sign support posts shall not be spliced.

ASSEMBLY PROCEDURE

Foundation

- Prepare 12-inch diameter by 42-inch deep hole. If solid rock is encountered, the depth of the foundation may be reduced such that it is embedded a minimum of 18 inches into the solid rock.
- The Engineer may permit batches of concrete less than 2 cubic yards to be mixed with a portable, motor-driven concrete mixer. For small placements less than 0.5 cubic yards, hand mixing in a suitable container may be allowed by Engineer. Concrete shall be Class A.
- Push the pipe end of the slip base stub into the center of the concrete. Rotate the stub back and forth while pushing it down into the concrete to assure good contact between the concrete and stub. Continue to work the stub into the concrete until it is between 2 to 4 inches above the ground.
- Plumb the stub. Allow a minimum of 4 days to set, unless otherwise directed by the Engineer.
- The triangular slipbase system is multidirectional and is designed to release when struck from any direction.

Support

- Cut support so that the bottom of the sign will be 7 to 7.5 feet above the edge of the travelway (i.e., edge of the closest lane) when slip plate is below the edge of pavement or 7 to 7.5 feet above slip plate when the slip plate is above the edge of the travelway. The cut shall be plumb and straight.
- Attach sign to support using connections shown. When multiple signs are installed on the same support, ensure the minimum clearance between each sign is maintained. See SMD(SLIP-2) for clearances based on sign types.

CONCRETE ANCHOR

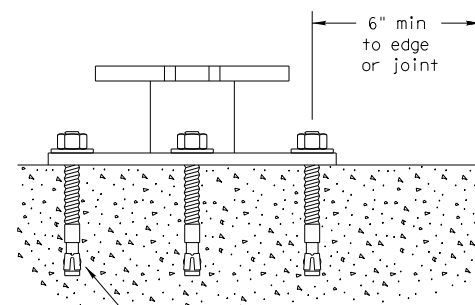

Concrete anchor consists of 5/8" diameter stud bolt with UNC series bolt threads on the upper end. Heavy hex nut per ASTM A563, and hardened washer per ASTM F436. The stud bolt shall have a minimum yield and ultimate tensile strength of 50 and 75 KSI, respectively. Nuts, bolts and washers shall be galvanized per Item 445, "Galvanizing." Adhesive type anchors shall have stud bolts installed with Type III epoxy per DMS-6100, "Epoxyes and Adhesives." Adhesive anchors may be loaded after adequate epoxy cure time per the manufacturer's recommendations. Top of bolt shall extend at least flush with top of the nut when installed. The anchor, when installed in 4000 psi normal-weight concrete with a 5 1/2" minimum embedment, shall have a minimum allowable tension and shear of 3900 and 3100 psi, respectively.

DATE:
FILE:

Texas Department of Transportation
Traffic Operations Division

SIGN MOUNTING DETAILS
SMALL ROADSIDE SIGNS
TRIANGULAR SLIPBASE SYSTEM

SMD(SLIP-1)-08

© TxDOT July 2002		DN: TxDOT	CK: TxDOT	DW: TxDOT	CK: TxDOT
9-08	REVISIONS	CONT	SECT	JOB	HIGHWAY
		0910	16	165	MLK JR
		DIST	COUNTY		SHEET NO.
		TYLER	SMITH		51

26B

DISCLAIMER: The use of this standard is governed by the "Texas Engineering Practice Act". No warranty of any kind is made by TxDOT for any purpose whatsoever. TxDOT assumes no responsibility for the conversion of this standard to other formats or for incorrect results or damages resulting from its use.

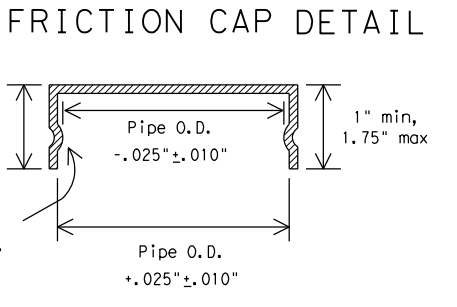
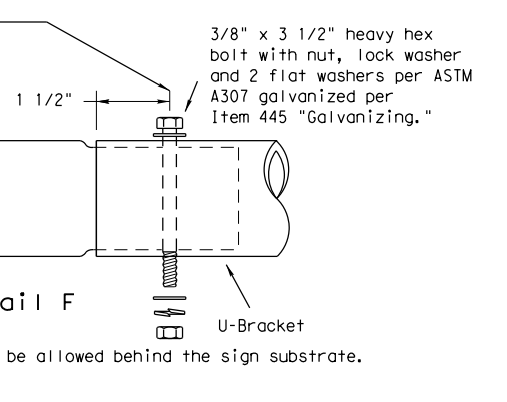
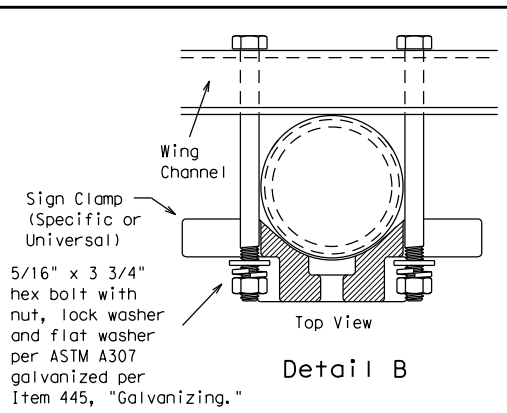
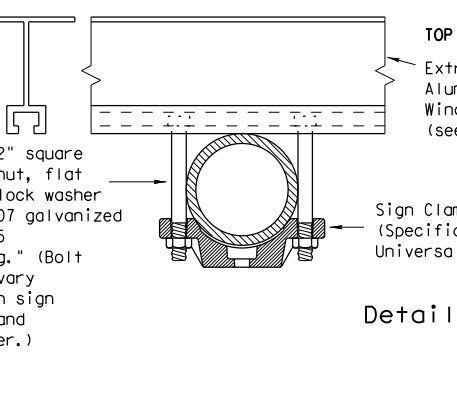
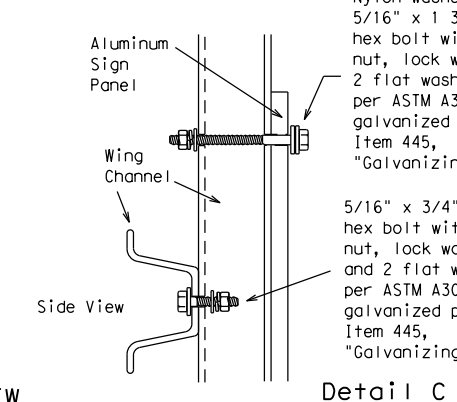
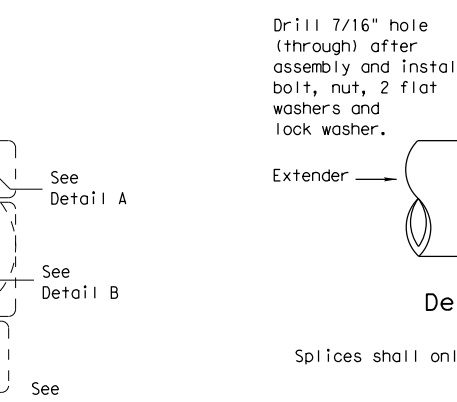
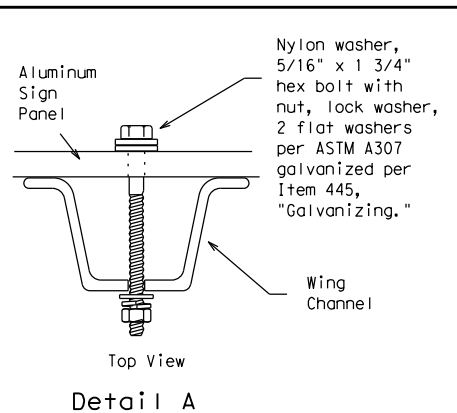
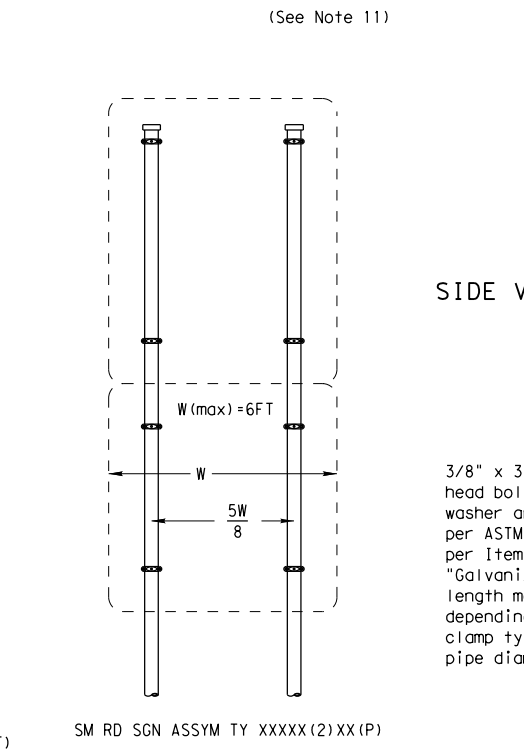
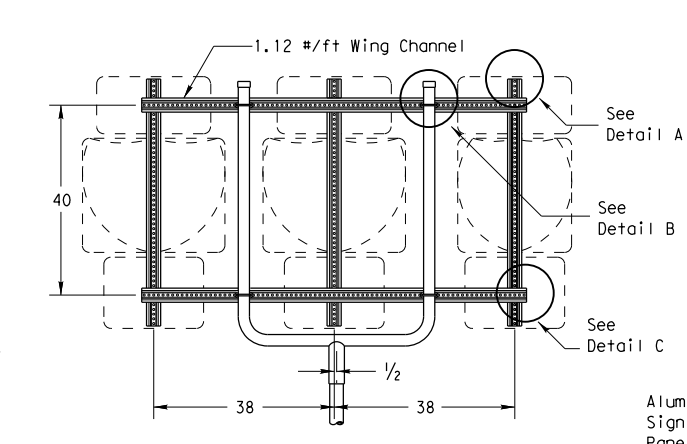
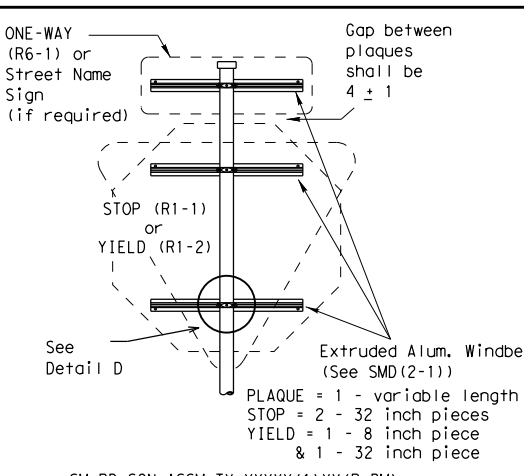
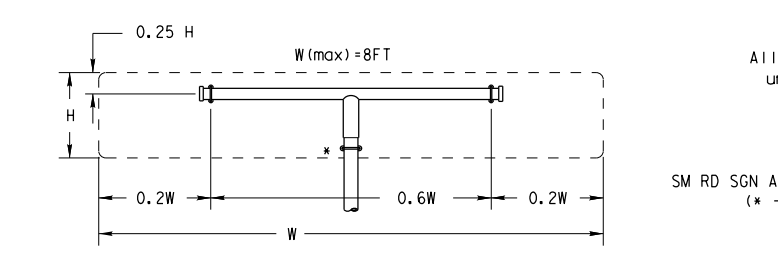
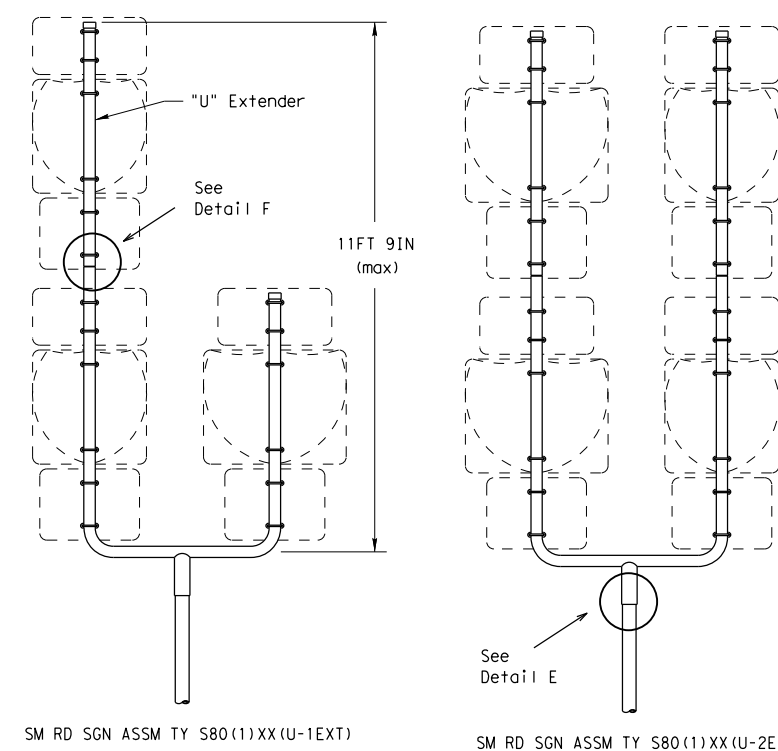
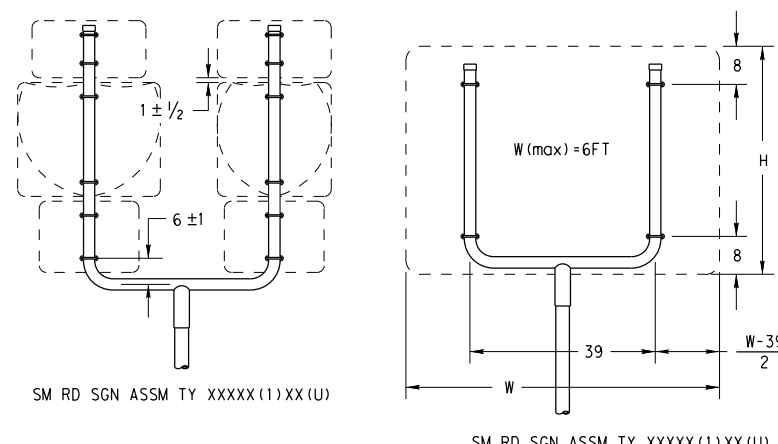
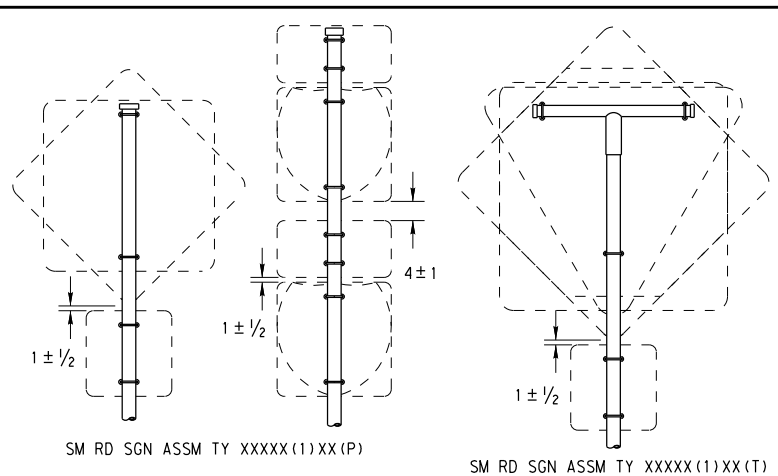

All dimensions are in english unless detailed otherwise.

SM RD SGN ASSM TY XXXXX(1)XX(T) (* - See Note 12)

GENERAL NOTES:

- | SIGN SUPPORT | # OF POSTS | MAX. SIGN AREA |
|--------------|------------|----------------|
| 10 BWG | 1 | 16 SF |
| 10 BWG | 2 | 32 SF |
| Sch 80 | 1 | 32 SF |
| Sch 80 | 2 | 64 SF |
- The Engineer may require that a Schedule 80 post be used in place of a 10 BWG where a sign height is abnormally high due to a fill slope.
- Sign supports shall not be spliced except where shown. Sign support posts shall not be spliced.
- Aluminum sign blanks shall conform to Departmental Material Specifications DMS-7110 and shall have the following minimum thicknesses: 0.080 for signs less than 7.5 sq. ft., 0.100 for signs 7.5 to 15 sq. ft., and 0.125 for signs greater than 15 sq. ft.
- Signs that require specific supports due to reasons in addition to windloading are indicated on the "REQUIRED SUPPORT" table on this sheet.
- For horizontal rectangular signs fabricated from flat aluminum, T-brackets are used for signs 24 inches or less in height. U-brackets are used for signs of greater height.
- When two triangular slipbase supports are used to support a single sign, they shall not be "rigidly" connected to each other except through the sign panel. This will allow each support to act independently when impacted by an errant vehicle.
- Wing channel shall meet ASTM A 1011 SS Gr 50 and be galvanized per ASTM A 123.
- Excess pipe, wing channel, or windbeam shall be cut off so that it does not extend beyond the sign panel (i.e., excess support shall not be visible when the sign is viewed from the front.) Repair galvanized coating at cut support ends per Item 445, "Galvanizing."
- Additional route markers may be added vertically, provided the total sign area does not exceed the maximum allowable amount per Note 1.
- Additional sign clamp required on the "T-bracket" post for 24 inch height signs. Place the clamp 3 inches above bottom of sign when possible.
- Post open ends shall be fitted with Friction Caps.
- Sign blanks shall be the sizes and shapes shown on the plans.

REQUIRED SUPPORT		
SIGN DESCRIPTION	SUPPORT	
Regulatory	48-inch STOP sign (R1-1)	TY 10BWG(1)XX(T) TY 10BWG(1)XX(P-BM)
	60-inch YIELD sign (R1-2)	TY 10BWG(1)XX(T) TY 10BWG(1)XX(P-BM)
	48x16-inch ONE-WAY sign (R6-1)	TY 10BWG(1)XX(T) TY 10BWG(1)XX(P-BM)
	36x48, 48x36, and 48x48-inch signs	TY 10BWG(1)XX(T)
Warning	48x60-inch signs	TY S80(1)XX(T)
	48x48-inch signs (diamond or square)	TY 10BWG(1)XX(T)
	48x60-inch signs	TY S80(1)XX(T)
	48-inch Advance School X-ing sign (S1-1)	TY 10BWG(1)XX(T)
	48-inch School X-ing sign (S2-1)	TY 10BWG(1)XX(T)
Large Arrow sign (W1-6 & W1-7)	TY 10BWG(1)XX(T)	

Friction caps may be manufactured from hot rolled or cold rolled steel sheets. The minimum sheet metal thickness shall be 24 gauge for all cap sizes. The rim edges shall be reasonably straight and smooth. Caps shall be sized and formed in such a manner as to produce a drive-on friction fit and have no tendency to rock when seated on the pipe. The depth shall be sufficient to give positive protection against entrance of rainwater. They shall be free of sharp creases or indentations and show no evidence of metal fracture. Caps shall have an electrodeposited coating of zinc in accordance with the requirements of ASTM B633 Class FE/ZN 8.



SIGN MOUNTING DETAILS
SMALL ROADSIDE SIGNS
TRIANGULAR SLIPBASE SYSTEM
SMD(SLIP-2)-08

© TxDOT July 2002		DN: TXDOT	CK: TXBOT	DW: TXBOT	CK: TXBOT
9-08	REVISIONS	CONT	SECT	JOB	HIGHWAY
		0910	16	165	MLK JR
		DIST	COUNTY		SHEET NO.
		TYLER	SMITH		52

DISCLAIMER: The use of this standard is governed by the "Texas Engineering Practice Act". No warranty of any kind is made by TxDOT for any purpose whatsoever. TxDOT assumes no responsibility for the conversion of this standard to other formats or for incorrect results or damages resulting from its use.

DATE:
FILE:

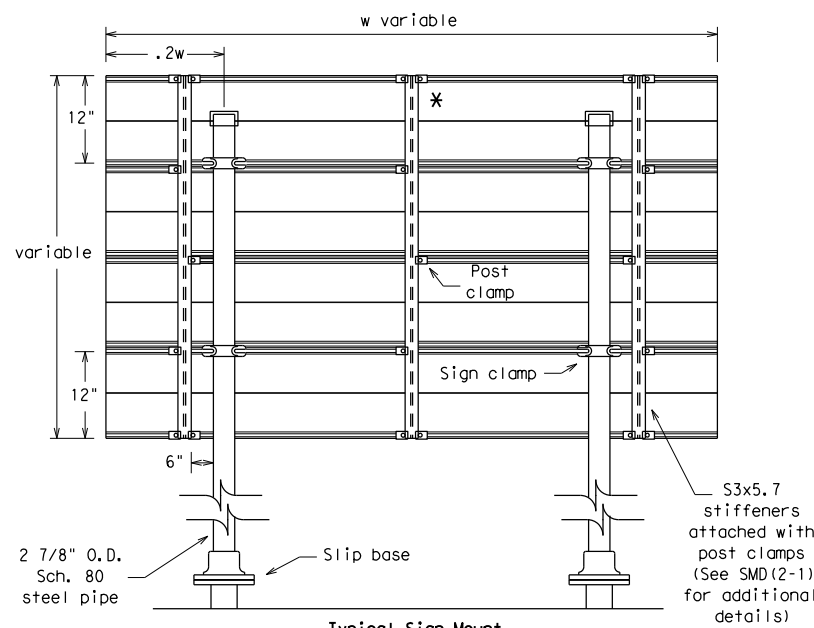
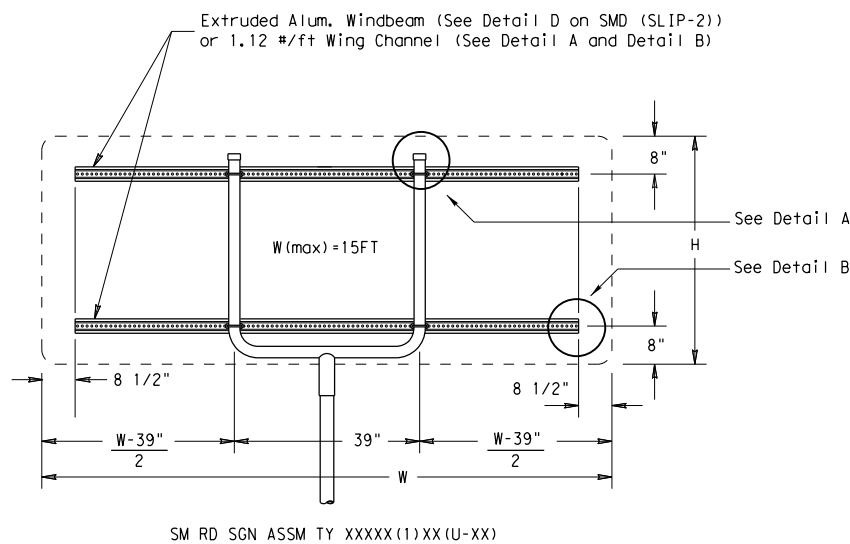
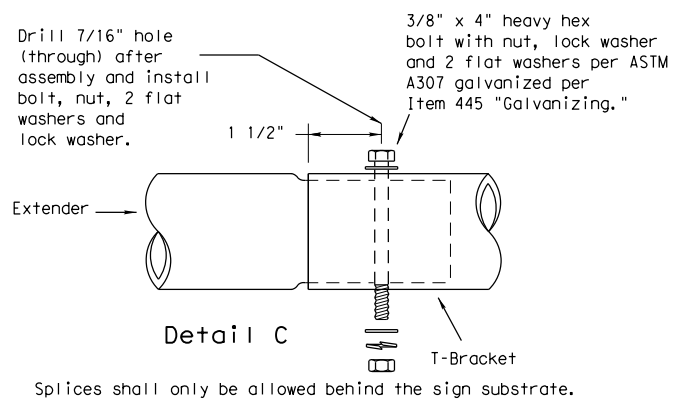
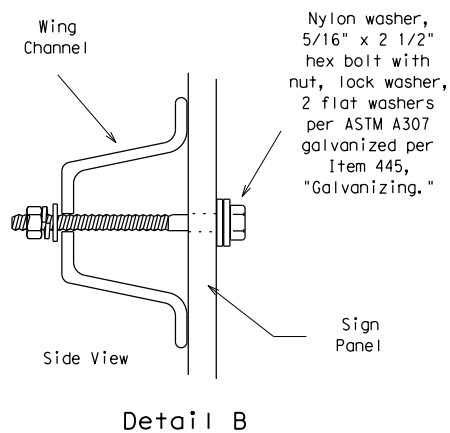
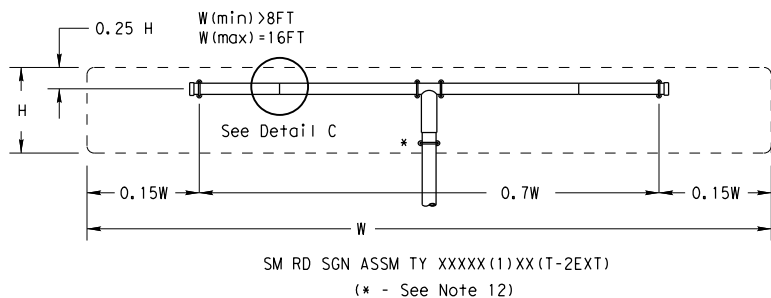

* Additional stiffener placed at approximate center of signs when sign width is greater than 10'.

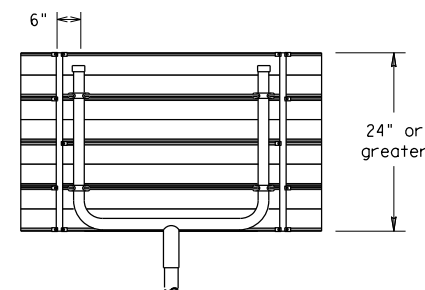
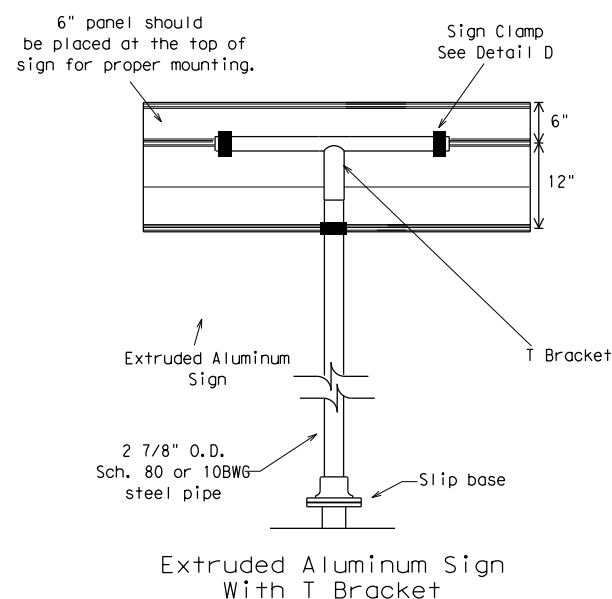
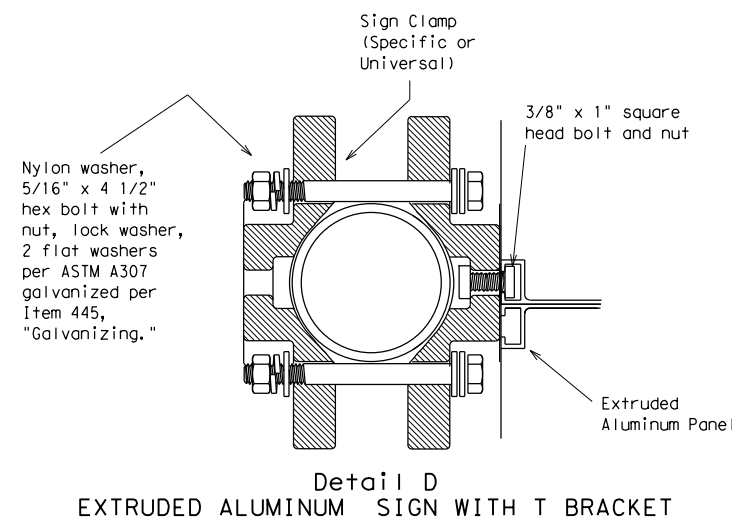
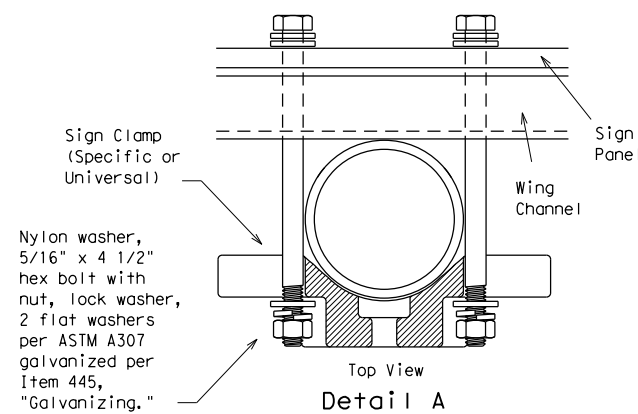
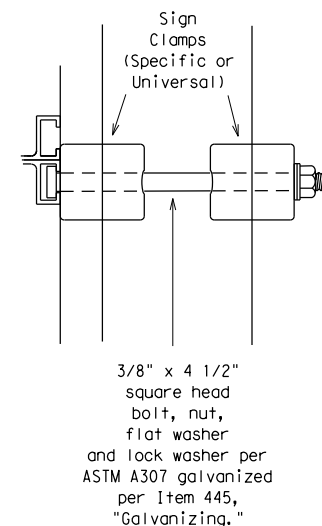

Use Extruded Alum. Windbeam as stiffeners See SMD (2-1) for additional details
See Detail E for clamp installation

GENERAL NOTES:

- | SIGN SUPPORT | # OF POSTS | MAX. SIGN AREA |
|--------------|------------|----------------|
| 10 BWG | 1 | 16 SF |
| 10 BWG | 2 | 32 SF |
| Sch 80 | 1 | 32 SF |
| Sch 80 | 2 | 64 SF |
- The Engineer may require that a Schedule 80 post be used in place of a 10 BWG where a sign height is abnormally high due to a fill slope.
- Sign supports shall not be spliced except where shown. Sign support posts shall not be spliced.
- Aluminum sign blanks shall conform to Departmental Material Specifications DMS-7110 and shall have the following minimum thicknesses: 0.080 for signs less than 7.5 sq. ft., 0.100 for signs 7.5 to 15 sq. ft., and 0.125 for signs greater than 15 sq. ft.
- Signs that require specific supports due to reasons in addition to windloading are indicated on the "REQUIRED SUPPORT" table on this sheet.
- For horizontal rectangular signs fabricated from flat aluminum, T-brackets are used for signs 24 inches or less in height. U-brackets are used for signs of greater height.
- When two triangular slipbase supports are used to support a single sign, they shall not be "rigidly" connected to each other except through the sign panel. This will allow each support to act independently when impacted by an errant vehicle.
- Wing channel shall meet ASTM A 1011 SS Gr 50 and be galvanized per ASTM A 123.
- Excess pipe, wing channel, or windbeam shall be cut off so that it does not extend beyond the sign panel (i.e., excess support shall not be visible when the sign is viewed from the front.) Repair galvanized coating at cut support ends per Item 445, "Galvanizing."
- Sign blanks shall be the sizes and shapes shown on the plans.
- Additional sign clamp required on the "T-bracket" post for 24 inch high signs. Place the clamp 3 inches above bottom of sign when possible.
- Post open ends shall be fitted with Friction Caps.

REQUIRED SUPPORT		
	SIGN DESCRIPTION	SUPPORT
Regulatory	48-inch STOP sign (R1-1)	TY 10BWG(1)XX(T) TY 10BWG(1)XX(P-BM)
	60-inch YIELD sign (R1-2)	TY 10BWG(1)XX(T) TY 10BWG(1)XX(P-BM)
	48x16-inch ONE-WAY sign (R6-1)	TY 10BWG(1)XX(T) TY 10BWG(1)XX(P-BM)
	36x48, 48x36, and 48x48-inch signs	TY 10BWG(1)XX(T)
Warning	48x60-inch signs	TY S80(1)XX(T)
	48x48-inch signs (diamond or square)	TY 10BWG(1)XX(T)
	48x60-inch signs	TY S80(1)XX(T)
	48-inch Advance School X-ing sign (S1-1)	TY 10BWG(1)XX(T)
	48-inch School X-ing sign (S2-1)	TY 10BWG(1)XX(T)
	Large Arrow sign (W1-6 & W1-7)	TY 10BWG(1)XX(T)

Texas Department of Transportation
Traffic Operations Division

SIGN MOUNTING DETAILS
SMALL ROADSIDE SIGNS
TRIANGULAR SLIPBASE SYSTEM
SMD(SLIP-3)-08

© TxDOT July 2002		DN: TXDOT	CK: TXBOT	DW: TXBOT	CK: TXBOT
9-08	REVISIONS	CONT	SECT	JOB	HIGHWAY
		0910	16	165	MLK JR
		DIST	COUNTY		SHEET NO.
		TYLER	SMITH		53

DISCLAIMER: The use of this standard is governed by the "Texas Engineering Practice Act". No warranty of any kind is made by TxDOT for any purpose whatsoever. TxDOT assumes no responsibility for the conversion of this standard to other formats or for incorrect results or damages resulting from its use.

DATE: FILE:

REQUIREMENTS FOR INDEPENDENT MOUNTED ROUTE SIGNS

SHEETING REQUIREMENTS		
USAGE	COLOR	SIGN FACE MATERIAL
BACKGROUND	WHITE	TYPE A SHEETING
BACKGROUND	ALL OTHERS	TYPE B OR C SHEETING
LEGEND & BORDERS	WHITE	TYPE A SHEETING
LEGEND & BORDERS	BLACK	ACRYLIC NON-REFLECTIVE FILM
LEGEND & BORDERS	ALL OTHERS	TYPE B or C SHEETING

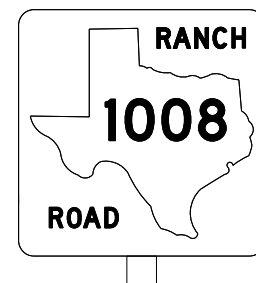
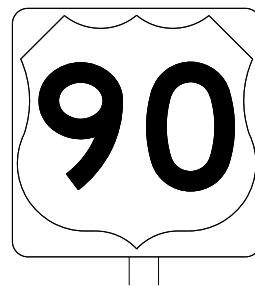

TYPICAL EXAMPLES

REQUIREMENTS FOR BLUE, BROWN & GREEN D AND I SERIES GUIDE SIGNS

SHEETING REQUIREMENTS		
USAGE	COLOR	SIGN FACE MATERIAL
BACKGROUND	ALL	TYPE B OR C SHEETING
LEGEND & BORDERS	WHITE	TYPE D SHEETING
LEGEND, SYMBOLS & BORDERS	ALL OTHERS	TYPE B OR C SHEETING

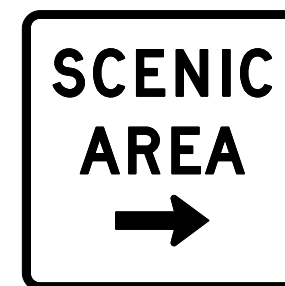
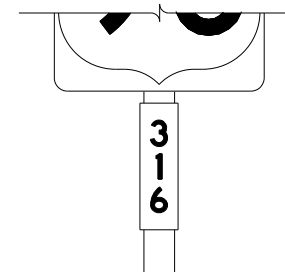

TYPICAL EXAMPLES

GENERAL NOTES

- Signs to be furnished shall be as detailed elsewhere in the plans and/or as shown on sign tabulation sheet. Standard sign designs and arrow dimensions can be found in the "Standard Highway Sign Designs for Texas" (SHSD).
- White legend shall use the Clearview Alphabet. The following Clearview fonts shall be used to replace the existing white Federal Highway Administration (FHWA) Standard Highway Alphabets, when not specified in the SHSD, or in the plans.

B	CV-1W
C	CV-2W
D	CV-3W
E	CV-4W
Emod	CV-5WR
F	CV-6W

- Route sign legend (ie. IH, US, SH and FM shields) shall use the Federal Highway Administration (FHWA) Standard Highway Alphabets B, C, D, E, Emod or F).
- Lateral spacing between letters and numerals shall conform with the SHSD, and any approved changes thereto. Lateral spacing of legend shall provide a balanced appearance when spacing is not shown.
- Independent mounted route sign with white or colored legend and borders shall be applied by screening process with transparent color ink, transparent colored overlay film to white background sheeting or cut-out white sheeting to colored background sheeting, or combination thereof. White legend, symbols and borders on all other signs shall be cut-out white sheeting applied to colored background sheeting.
- Information regarding borders and radii for signs is found in the "Standard Highway Sign Designs for Texas". Dimensions shown and described for borders and corner radii on parent sign are nominal. Borders may vary in width as much as 1/2 inch. Corner radii above 3 inches may vary in width as much as 1 inch. Borders and corner radii within a parent sign must be of matching widths. The sign area outside the corner radius should be trimmed or rounded.
- Sign substrate shall be any material that meets the Departmental Material Specification requirements of DMS-7110 or approved alternative.
- Mounting details of roadside signs are shown in the "SMD series" Standard Plan Sheets.

DEPARTMENTAL MATERIAL SPECIFICATIONS	
ALUMINUM SIGN BLANKS	DMS-7110
SIGN FACE MATERIALS	DMS-8300

ALUMINUM SIGN BLANKS THICKNESS	
Square Feet	Minimum Thickness
Less than 7.5	0.080
7.5 to 15	0.100
Greater than 15	0.125

The Standard Highway Sign Designs for Texas (SHSD) can be found at the following website.

<http://www.txdot.gov/>



TYPICAL SIGN REQUIREMENTS

TSR(3) - 13

FILE: tsr3-13.dgn	DN: TxDOT	CK: TxDOT	DW: TxDOT	CK: TxDOT
© TxDOT October 2003	CONT	SECT	JOB	HIGHWAY
REVISIONS	0910	16	165	MLK JR
12-03 7-13	DIST	COUNTY	SHEET NO.	
9-08	TYLER	SMITH	54	

DISCLAIMER: The use of this standard is governed by the "Texas Engineering Practice Act". No warranty of any kind is made by TxDOT for any purpose whatsoever. TxDOT assumes no responsibility for the conversion of this standard to other formats or for incorrect results or damages resulting from its use.

DATE: FILE:

REQUIREMENTS FOR RED BACKGROUND REGULATORY SIGNS

(STOP, YIELD, DO NOT ENTER AND WRONG WAY SIGNS)

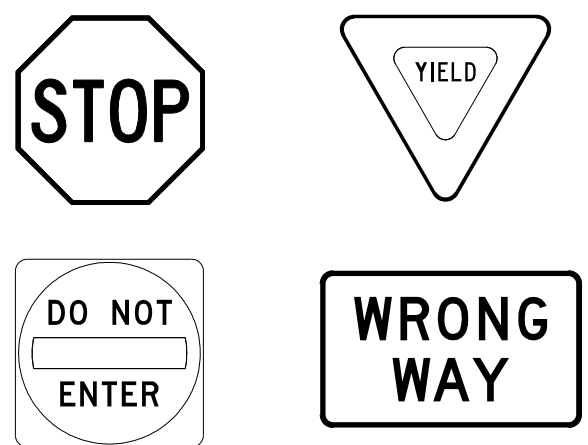

REQUIREMENTS FOR FOUR SPECIFIC SIGNS ONLY

SHEETING REQUIREMENTS		
USAGE	COLOR	SIGN FACE MATERIAL
BACKGROUND	RED	TYPE B OR C SHEETING
BACKGROUND	WHITE	TYPE B OR C SHEETING
LEGEND & BORDERS	WHITE	TYPE B OR C SHEETING
LEGEND	RED	TYPE B OR C SHEETING

REQUIREMENTS FOR WHITE BACKGROUND REGULATORY SIGNS

(EXCLUDING STOP, YIELD, DO NOT ENTER AND WRONG WAY SIGNS)



TYPICAL EXAMPLES

SHEETING REQUIREMENTS		
USAGE	COLOR	SIGN FACE MATERIAL
BACKGROUND	WHITE	TYPE A SHEETING
BACKGROUND	ALL OTHERS	TYPE B OR C SHEETING
LEGEND, BORDERS AND SYMBOLS	BLACK	ACRYLIC NON-REFLECTIVE FILM
LEGEND, BORDERS AND SYMBOLS	ALL OTHER	TYPE B OR C SHEETING

REQUIREMENTS FOR WARNING SIGNS

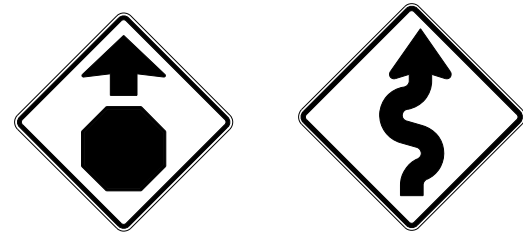

TYPICAL EXAMPLES

SHEETING REQUIREMENTS		
USAGE	COLOR	SIGN FACE MATERIAL
BACKGROUND	FLOURESCENT YELLOW	TYPE B _{FL} OR C _{FL} SHEETING
LEGEND & BORDERS	BLACK	ACRYLIC NON-REFLECTIVE FILM
LEGEND & SYMBOLS	ALL OTHER	TYPE B OR C SHEETING

REQUIREMENTS FOR SCHOOL SIGNS



TYPICAL EXAMPLES

SHEETING REQUIREMENTS		
USAGE	COLOR	SIGN FACE MATERIAL
BACKGROUND	WHITE	TYPE A SHEETING
BACKGROUND	FLOURESCENT YELLOW GREEN	TYPE B _{FL} OR C _{FL} SHEETING
LEGEND, BORDERS AND SYMBOLS	BLACK	ACRYLIC NON-REFLECTIVE FILM
SYMBOLS	RED	TYPE B OR C SHEETING

GENERAL NOTES

- Signs to be furnished shall be as detailed elsewhere in the plans and/or as shown on sign tabulation sheet. Standard sign designs and arrow dimensions can be found in the "Standard Highway Sign Designs for Texas" (SHSD).
- Sign legend shall use the Federal Highway Administration (FHWA) Standard Highway Alphabets (B, C, D, E, Emod or F).
- Lateral spacing between letters and numerals shall conform with the SHSD, and any approved changes thereto. Lateral spacing of legend shall provide a balanced appearance when spacing is not shown.
- Black legend and borders shall be applied by screening process or cut-out acrylic non-reflective black film to background sheeting, or combination thereof.
- White legend and borders shall be applied by screening process with transparent colored ink, transparent colored overlay film to white background sheeting or cut-out white sheeting to colored background sheeting, or combination thereof.
- Colored legend shall be applied by screening process with transparent colored ink, transparent colored overlay film or colored sheeting to background sheeting, or combination thereof.
- Sign substrate shall be any material that meets the Departmental Material Specification requirements of DMS-7110 or approved alternative.
- Mounting details for roadside mounted signs are shown in the "SMD series" Standard Plan Sheets.

ALUMINUM SIGN BLANKS THICKNESS	
Square Feet	Minimum Thickness
Less than 7.5	0.080
7.5 to 15	0.100
Greater than 15	0.125

DEPARTMENTAL MATERIAL SPECIFICATIONS	
ALUMINUM SIGN BLANKS	DMS-7110
SIGN FACE MATERIALS	DMS-8300

The Standard Highway Sign Designs for Texas (SHSD) can be found at the following website:
<http://www.txdot.gov/>



TYPICAL SIGN REQUIREMENTS

TSR(4) - 13

FILE: tsr4-13.dgn	DN: TxDOT	CK: TxDOT	DW: TxDOT	CK: TxDOT
© TxDOT October 2003	CONT	SECT	JOB	HIGHWAY
REVISIONS	0910	16	165	MLK JR
12-03 7-13	DIST	COUNTY	SHEET NO.	
9-08	TYLER	SMITH	55	

DISCLAIMER: The use of this standard is governed by the "Texas Engineering Practice Act". No warranty of any kind is made by TxDOT for any purpose whatsoever. TxDOT assumes no responsibility for the conversion of this standard to other formats or for incorrect results or damages resulting from its use.

DATE: DATE TIME
FILE: DOCUMENT NAME

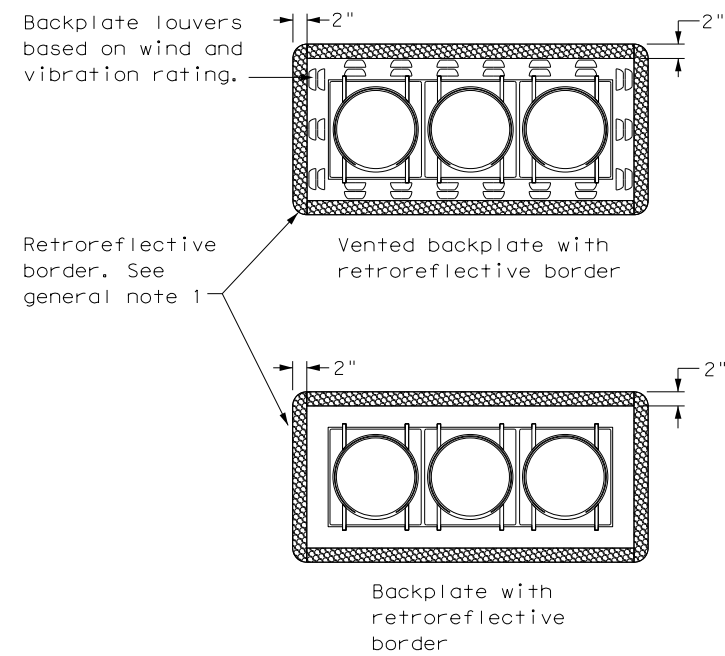

THREE-SECTION HEAD
HORIZONTAL OR VERTICAL

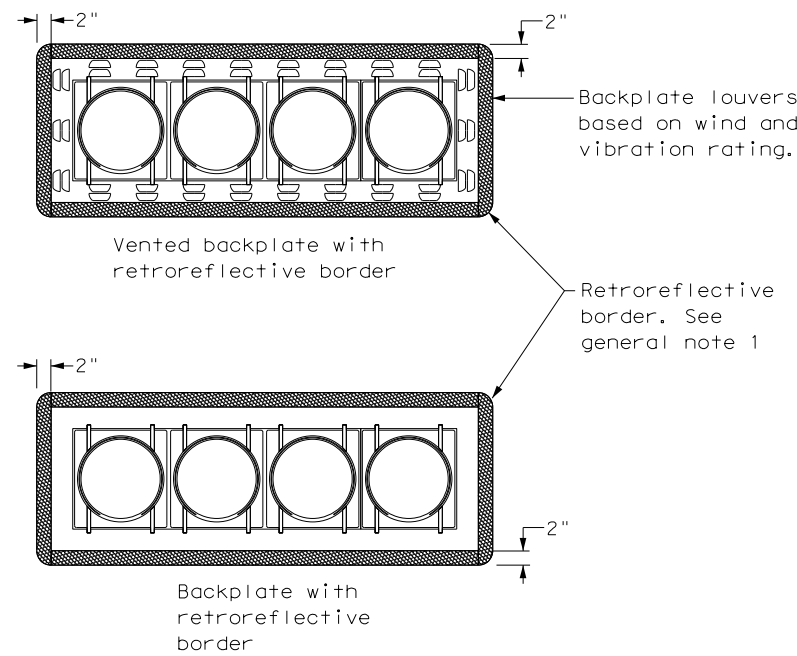

FOUR-SECTION HEAD
HORIZONTAL OR VERTICAL

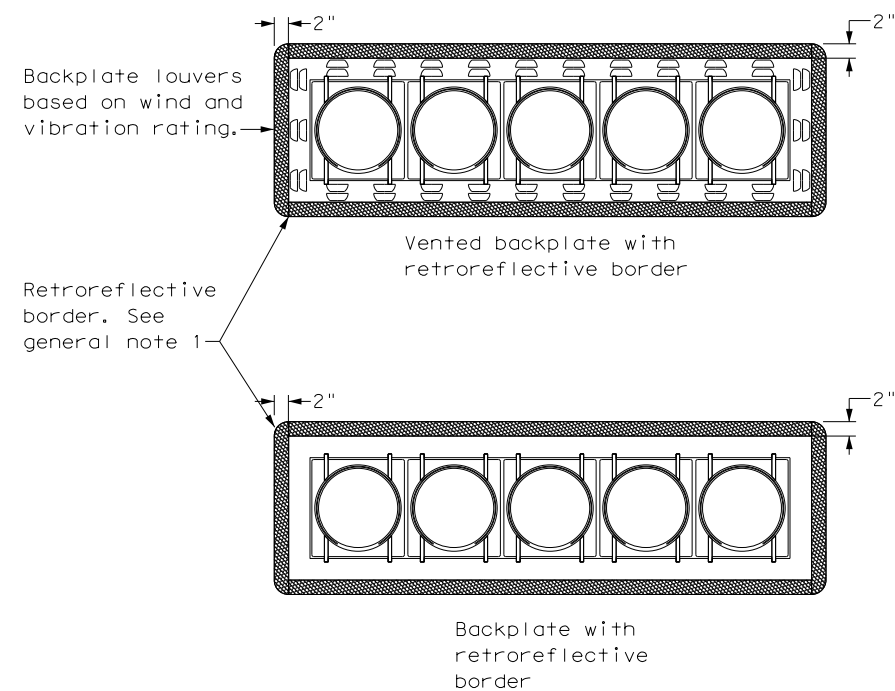

FIVE-SECTION HEAD
HORIZONTAL OR VERTICAL

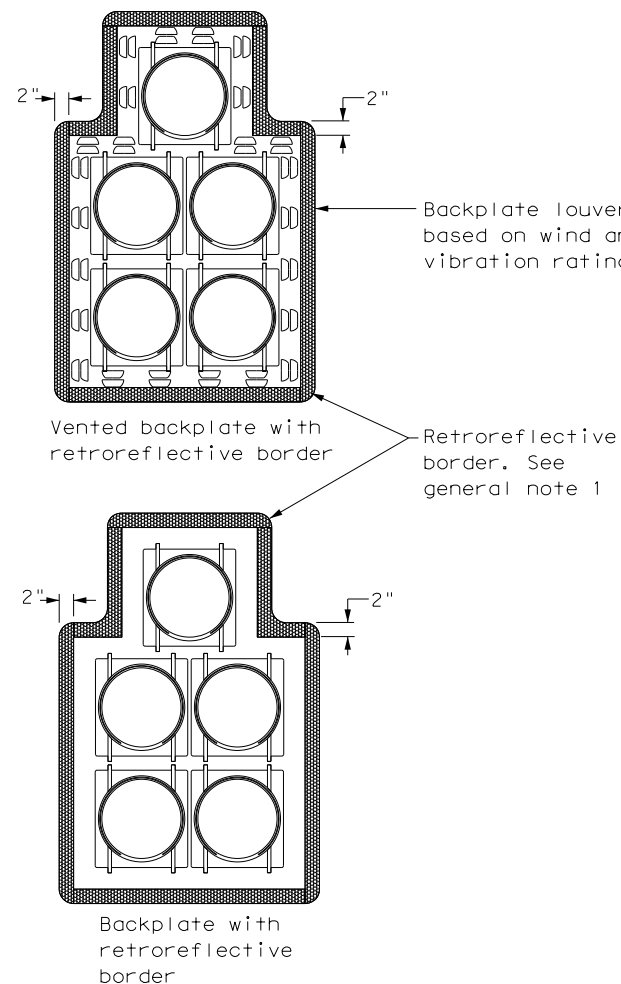

FIVE-SECTION HEAD
CLUSTER

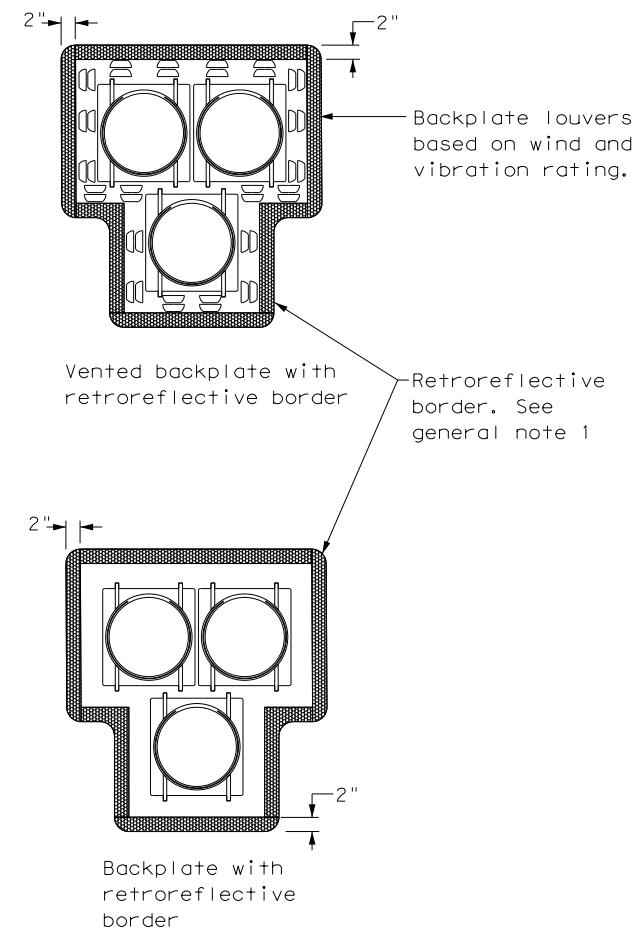

PEDESTRIAN HYBRID
BEACON

GENERAL NOTES:

1. Backplates are optional for traffic signals and pedestrian hybrid beacons. When backplates are used, a 2-inch wide fluorescent yellow AASHTO Type B_{FL} or C_{FL} retroreflective border conforming to TxDOT DMS-8300 is required. Place on all approaches when used.
2. Signal head and backplate compatibility must be verified by the contractor prior to installation.
3. When using backplates on signal heads, venting is preferred to reduce cyclic vibration stress.
4. When a vented backplate is used, the retroreflective border must not be placed over the louvers.
5. This standard sheet applies to all signal heads with backplates, including but not limited to:
 - Pole mounted
 - Overhead mounted
 - Span wire mounted
 - Mast arm mounted
 - Vertical signal heads
 - Horizontal signal heads
 - Clustered signal heads
 - Pedestrian hybrid beacons

<p>TRAFFIC SIGNAL HEAD WITH BACKPLATE</p> <p>TS-BP-20</p>				
FILE: ts-bp-20.dgn	DN: TxDOT	CK: TxDOT	DW: TxDOT	CK: TxDOT
© TxDOT June 2020	CONT	SECT	JOB	HIGHWAY
REVISIONS	0910	16	165	MLK JR
	DIST	COUNTY	SHEET NO.	
	TYLER	SMITH	56	

DISCLAIMER: The use of this standard is governed by the "Texas Engineering Practice Act". No warranty of any kind is made by TxDOT for any purpose whatsoever. TxDOT assumes no responsibility for the conversion of this standard to other formats or for incorrect results or damages resulting from its use.

DATE: 5/13/2022 1:38:00 PM
 FILE: \\k:\miley-horn.com\TX-DAL2\DAL2\TPT0\1project\063615008 - Tyler HSIP PS&E\CADD\Standards\MLK Corridor\TYL - TS-FD-12.dgn

FDN TYPE	DRILLED SHAFT DIA	REINFORCING STEEL		EMBEDDED DRILLED SHAFT LENGTH-ft (4), (5), (6)			ANCHOR BOLT DESIGN (1)			FOUNDATION DESIGN LOAD (2)		TYPICAL APPLICATION	
		VERT BARS	SPIRAL & PITCH	TEXAS CONE PENETROMETER N blows/ft			ANCHOR BOLT DIA	Fy (ksi)	BOLT CIR DIA	ANCHOR TYPE	MOMENT K-ft		SHEAR Kips
				10	15	40							
24-A	24"	4- #5	#2 at 12"	5.7	5.3	4.5	3/4"	36	12 3/4"	1	10	1	Pedestal pole, pedestal mounted controller.
30-A	30"	8- #9	#3 at 6"	11.3	10.3	8.0	1 1/2"	55	17"	2	87	3	Mast arm assembly. (see Selection Table)
36-A	36"	10- #9	#3 at 6"	13.2	12.0	9.4	1 3/4"	55	19"	2	131	5	Mast arm assembly. (see Selection Table) 30' strain pole with or without luminaire.
36-B	36"	12- #9	#3 at 6"	15.2	13.6	10.4	2"	55	21"	2	190	7	Mast arm assembly. (see Selection Table) Strain pole taller than 30' & strain pole with mast arm
42-A	42"	14- #9	#3 at 6"	17.4	15.6	11.9	2 1/4"	55	23"	2	271	9	Mast arm assembly. (see Selection Table)

FOUNDATION SELECTION TABLE FOR STANDARD MAST ARM PLUS ILSN SUPPORT ASSEMBLIES (ft)					
80 MPH DESIGN WIND SPEED	MAX SINGLE ARM LENGTH	FDN 30-A	FDN 36-A	FDN 36-B	FDN 42-A
		MAXIMUM DOUBLE ARM LENGTH COMBINATIONS	24' X 24' 28' X 28' 32' X 28'	32' X 32' 36' X 36' 40' X 36' 44' X 28'	44' X 36'
100 MPH DESIGN WIND SPEED	MAX SINGLE ARM LENGTH		36'	44'	
		MAXIMUM DOUBLE ARM LENGTH COMBINATIONS	24' X 24' 28' X 28' 32' X 24'	32' X 32' 36' X 36' 40' X 24'	40' X 36' 44' X 36'

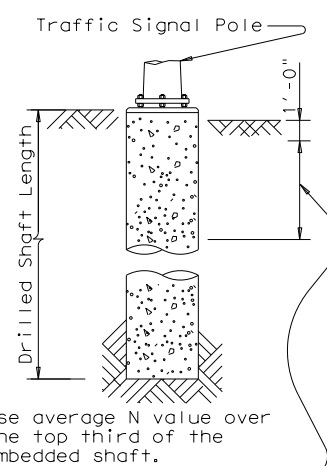

ANCHOR BOLT & TEMPLATE SIZES						
BOLT DIA IN.	(7) BOLT LENGTH	TOP THREAD	BOTTOM THREAD	BOLT CIRCLE	R2	R1
3/4"	1'-6"	3"	—	12 3/4"	7 1/8"	5 5/8"
1 1/2"	3'-4"	6"	4"	17"	10"	7"
1 3/4"	3'-10"	7"	4 1/2"	19"	11 1/4"	7 3/4"
2"	4'-3"	8"	5"	21"	12 1/2"	8 1/2"
2 1/4"	4'-9"	9"	5 1/2"	23"	13 3/4"	9 1/4"

(7) Min dimensions given, longer bolts are acceptable.

- EXAMPLE:
- For 80mph design wind speed, foundation 30-A can support up to a 32' arm with another arm up to 28'
 - For 100mph design wind speed, foundation 36-A can support a single 36' mast arm.

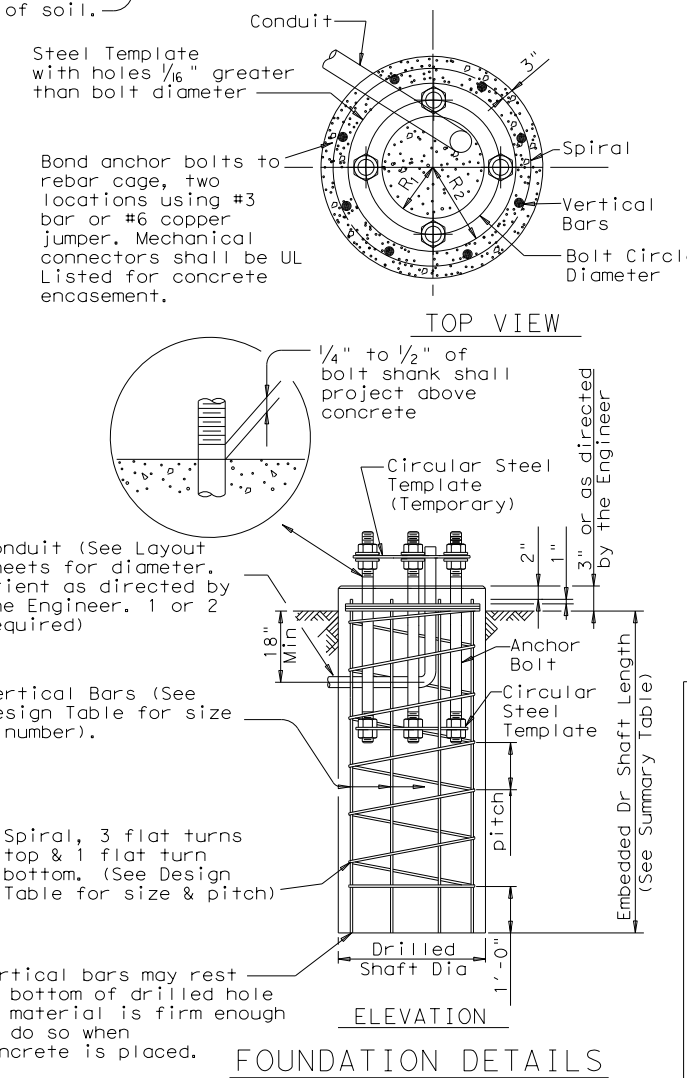
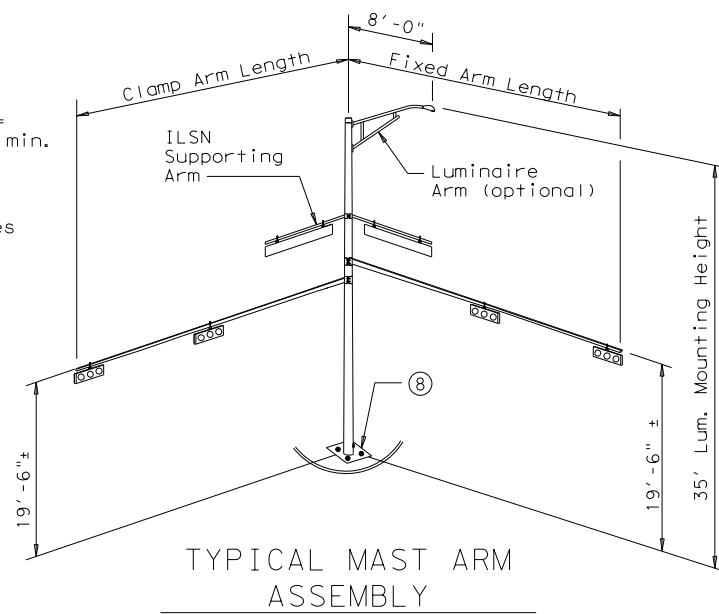
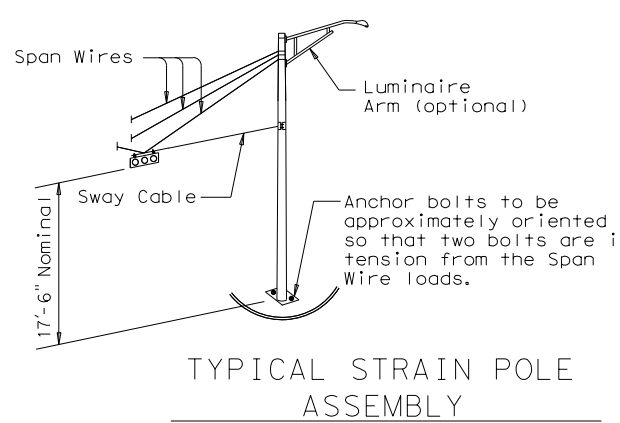
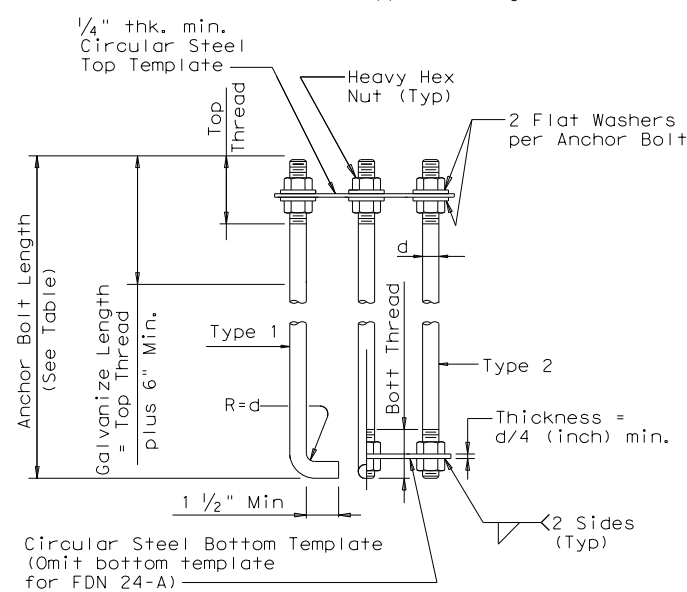

NOTES:

- Anchor bolt design develops the foundation capacity given under Foundation Design Loads.
- Foundation Design Loads are the allowable moments and shears at the base of the structure.
- Foundations may be listed separately or grouped according to similarity of location and type. Quantities are for the Contractor's information only.
- Field Penetrometer readings at a depth of approximately 3 to 5 feet may be used to adjust shaft lengths.
- If rock is encountered, the Drilled Shaft shall extend a minimum of two diameters into solid rock.
- Decimal lengths in Design Table are to allow interpolation for other penetrometer values. Round to nearest foot for entry into Summary Table.

FOUNDATION SUMMARY TABLE (3)

LOCATION IDENTIFICATION	AVG. N BLOW /ft.	FDN TYPE	NO. EA	DRILLED SHAFT LENGTH (6) (FEET)				
				24-A	30-A	36-A	36-B	42-A
W. MLK JR. BLVD AT BROADWAY AVE	10	24-A	5	30				
TOTAL DRILLED SHAFT LENGTHS				30				

GENERAL NOTES:

Design conforms to 1994 AASHTO Standard Specifications for Structural Supports for Highway Signs, Luminaires and Traffic Signals and interim revisions thereto.

Reinforcing steel shall conform to Item 440, "Reinforcing Steel".

Concrete shall be Class "C".

Threads for anchor bolts and nuts shall be rolled or cut threads of 8UN series up to 2" in diameter or UNC series for all sizes. Bolts and nuts shall have Class 2A and 2B fit tolerances. Galvanized nuts shall be tapped after galvanizing.

Anchor bolts that are larger than 1" in diameter shall conform to "alloy steel" or "medium-strength mild steel" per Item 449, "Anchor Bolts". Anchor bolts that are 1" in diameter or less shall conform to ASTM A36. Galvanize a minimum of the top end thread length plus 6" for all anchor bolts unless otherwise noted. Exposed washers and exposed nuts shall be galvanized. All galvanizing shall be in accordance with Item 445, "Galvanizing".

Templates and embedded nuts need not be galvanized. Lubricate and tighten anchor bolts when erecting the structure in accordance with Item 449, "Anchor Bolts".



Texas Department of Transportation
 Traffic Operations Division

TRAFFIC SIGNAL
 POLE FOUNDATION

TS-FD-12

© TxDOT August 1995		DN: MS	CK: JSY	DW: MAO/MMF	CK: JSY/TEB
REVISIONS		CONT	SECT	JOB	HIGHWAY
5-96		0910	16	165	MLK JR
11-99		DIST	COUNTY		SHEET NO.
1-12		TYL	SMITH		57

A. GENERAL SITE DATA

1. PROJECT LIMITS: TWO SIGNALIZED INTERSECTIONS ALONG MLK BOULEVARD AT PALACE AVENUE AND BROADWAY AVENUE

PROJECT LOCATION:
 BEGIN PROJECT : PALACE AVENUE
 END PROJECT : BROADWAY AVENUE

PROJECT COORDINATES:
 BEG LATITUDE: +32.370350 BEG LONGITUDE: -95.309808
 END LATITUDE: +32.370119 END LONGITUDE: -95.301936

2. PROJECT SITE MAPS:
 * PROJECT LOCATION MAP: TITLE SHEET
 * DRAINAGE PATTERNS: N/A
 * SLOPES ANTICIPATED AFTER MAJOR GRADINGS OR AREAS OF SOIL DISTURBANCE: N/A
 * LOCATION OF EROSION AND SEDIMENT CONTROLS: N/A
 * SURFACE WATERS AND DISCHARGE LOCATIONS: N/A
 * PROJECT SPECIFIC LOCATIONS: TO BE SPECIFIED BY THE PROJECT FIELD OFFICE DURING CONSTRUCTION AND LOCATED IN THE PROJECT SW3P FILE. REFERENCE ITEM #10 BELOW

3. PROJECT DESCRIPTION:
 TRAFFIC SIGNAL IMPROVEMENTS, IMPROVEMENTS TO PEDESTRIAN FACILITIES, VEHICLE DETECTION IMPROVEMENTS, AND WIRELESS COMMUNICATION IMPROVEMENTS AT PROJECT INTERSECTIONS.

4. MAJOR SOIL DISTURBING ACTIVITIES:
 DRILL SHAFT INSTALLATIONS, CONDUIT INSTALLATIONS, GROUND BOX INSTALLATIONS, ETC.

5. EXISTING CONDITION OF SOIL & VEGETATIVE COVER AND % OF EXISTING VEGETATIVE COVER:
 WELL MAINTAINED SOD WITH APPROXIMATELY 90% COVERAGE.

6. TOTAL PROJECT AREA: 1.2 ACRES

7. TOTAL AREA TO BE DISTURBED: 0.012 ACRES

8. WEIGHTED RUNOFF COEFFICIENT
 BEFORE CONSTRUCTION: 0.90
 AFTER CONSTRUCTION: 0.90

9. NAME OF RECEIVING WATERS: (SEGMENT NUMBER OF RECEIVING WATERS)
 SEGMENT 0606 - NECHES RIVER ABOVE LAKE PALESTINE

10. PROJECT SW3P FILE: FOR PROJECTS DISTURBING ONE ACRE OR MORE, TXDOT WILL MAINTAIN AN SW3P FILE WITH ALL PERTINENT ENVIRONMENTAL DOCUMENTS, CORRESPONDENCE, ETC. AT THE PROJECT FIELD OFFICE. IF NO FIELD OFFICE IS AVAILABLE THEN THE SW3P FILE SHALL BE KEPT IN THE INSPECTOR'S TRUCK.

B. EROSION AND SEDIMENT CONTROLS

1. SOIL STABILIZATION PRACTICES:

- TEMPORARY SEEDING
- PERMANENT PLANTING, SODDING, OR SEEDING
- MULCHING
- SOIL RETENTION BLANKET
- BUFFER ZONES
- PRESERVATION OF NATURAL RESOURCES

OTHER:

2. STRUCTURAL PRACTICES:

- SILT FENCES
- ROCK FILTER DAMS
- DIVERSION, INTERCEPTOR, OR PERIMETER DIKES
- DIVERSION, INTERCEPTOR, OR PERIMETER SWALES
- DIVERSION DIKE AND SWALE COMBINATIONS
- PIPE SLOPE DRAINS
- PAVED FLUMES
- ROCK BEDDING AT CONSTRUCTION EXIT
- TIMBER MATTING AT CONSTRUCTION EXIT
- CHANNEL LINERS
- SEDIMENT TRAPS
- SEDIMENT BASINS
- STORM INLET SEDIMENT TRAP
- STONE OUTLET STRUCTURES
- CURBS AND GUTTERS
- STORM SEWERS
- VELOCITY CONTROL DEVICES

OTHER: EROSION CONTROL LOGS

3. STORM WATER MANAGEMENT:

STORM WATER DRAINAGE WILL BE PROVIDED BY MUNICIPAL STORM WATER SYSTEM
 THIS SYSTEM WILL CARRY THE DRAINAGE WITHIN THE RIGHT-OF-WAY TO NATURAL CHANNELS

4. STORM WATER MANAGEMENT ACTIVITIES: (SEQUENCE OF CONSTRUCTION)

USE EROSION CONTROL LOGS, IF NEEDED

5. NON-STORM WATER DISCHARGES:

FILTER NON-STORM WATER DISCHARGES, OR HOLD RETENTION BASINS, BEFORE BEING ALLOWED TO MIX WITH STORM WATER. THESE DISCHARGES CONSIST OF NON-POLLUTED GROUND WATER, SPRING WATER, FOUNDATION AND/OR FOOTING DRAIN WATER; AND WATER USED FOR DUST CONTROL, PAVEMENT WASHING AND VEHICLE WASHWATER CONTAINING NO DETERGENTS.

C. OTHER REQUIREMENTS & PRACTICES

1. MAINTENANCE:

MAINTENANCE WILL BE PERFORMED AS INDICATED ON FIELD INSPECTION AND MAINTENANCE REPORT FORM 2118.

2. INSPECTION:

INSPECTION WILL BE PERFORMED AS INDICATED ON FIELD INSPECTION AND MAINTENANCE REPORT FORM 2118.

3. WASTE MATERIALS:

ALL WASTE MATERIALS WILL BE COLLECTED, STORED AND DISPOSED OF IN A LIDDED DUMPSTER IN A LEGAL AND PROPER MANNER. NO CONSTRUCTION WASTE MATERIAL WILL BE BURIED ON SITE.

4. HAZARDOUS WASTE (INCLUDING SPILL REPORTING):

AT A MINIMUM, ANY PRODUCTS IN THE FOLLOWING CATEGORIES ARE CONSIDERED TO BE HAZARDOUS. PAINTS, ACIDS FOR CLEANING MASONRY SURFACES, CLEANING SOLVENTS, ASPHALT PRODUCTS, CHEMICAL ADDITIVES FOR SOIL STABILIZATION, OR CONCRETE CURING COMPOUNDS AND ADDITIVES. IN THE EVENT OF A SPILL WHICH MAY BE HAZARDOUS, THE SPILL COORDINATOR MUST BE CONTACTED IMMEDIATELY.

5. SANITARY WASTE:

ALL SANITARY WASTE WILL BE COLLECTED FROM THE PORTABLE UNITS AS NECESSARY OR AS REQUIRED BY LOCAL REGULATION BY A LICENSED SANITARY WASTE MANAGEMENT CONTRACTOR.

OFFSITE VEHICLE TRACKING:

- HAUL ROADS DAMPENED FOR DUST CONTROL
- LOADED HAUL TRUCKS TO BE COVERED WITH TARPAULIN
- EXCESS DIRT ON ROAD REMOVED DAILY
- STABILIZED CONSTRUCTION ENTRANCE

OTHER:

REMARKS: DISPOSAL AREAS, STOCKPILES AND HAUL ROADS SHALL BE CONSTRUCTED IN A MANNER THAT WILL MINIMIZE AND CONTROL SEDIMENT FROM ENTERING RECEIVING WATERS. DISPOSAL AREAS SHALL NOT BE LOCATED IN ANY WATERBODY OR STREAMBED.

CONSTRUCTION STAGING AREAS AND VEHICLE MAINTENANCE AREAS SHALL BE CONSTRUCTED TO MINIMIZE THE RUNOFF OF POLLUTANTS.

5/13/2022



THE AFFIXED SEAL ABOVE APPLIES ONLY TO INFORMATION FILLED BY ABOVE STATED ENGINEER.

MLK BLVD
 STORM WATER
 POLLUTION
 PREVENTION
 PLAN (SW3P)



CONT	SECT	JOB	HIGHWAY
0910	16	165	MLK JR
DIST	COUNTY	SHEET NO.	
TYL	SMITH	58	

DISCLAIMER: The use of this standard is governed by the "Texas Engineering Practice Act". No warranty of any kind is made by TxDOT for any purpose whatsoever. TxDOT assumes no responsibility for the conversion of this standard to other formats or for incorrect results or damages resulting from its use.

DATE:
FILE:

I. STORMWATER POLLUTION PREVENTION-CLEAN WATER ACT SECTION 402

TPDES TXR 150000: Stormwater Discharge Permit or Construction General Permit required for projects with 1 or more acres disturbed soil. Projects with any disturbed soil must protect for erosion and sedimentation in accordance with Item 506.

List MS4 Operator(s) that may receive discharges from this project. They may need to be notified prior to construction activities.

1. City of Tyler

2.

No Action Required Required Action

Action No.

1. Prevent stormwater pollution by controlling erosion and sedimentation in accordance with TPDES Permit TXR 150000
2. Comply with the SW3P and revise when necessary to control pollution or required by the Engineer.
3. Post Construction Site Notice (CSN) with SW3P information on or near the site, accessible to the public and TCEQ, EPA or other inspectors.
4. When Contractor project specific locations (PSL's) increase disturbed soil area to 5 acres or more, submit NOI to TCEQ and the Engineer.

II. WORK IN OR NEAR STREAMS, WATERBODIES AND WETLANDS CLEAN WATER ACT SECTIONS 401 AND 404

USACE Permit required for filling, dredging, excavating or other work in any water bodies, rivers, creeks, streams, wetlands or wet areas.

The Contractor must adhere to all of the terms and conditions associated with the following permit(s):

- No Permit Required
- Nationwide Permit 14 - PCN not Required (less than 1/10th acre waters or wetlands affected)
- Nationwide Permit 14 - PCN Required (1/10 to <1/2 acre, 1/3 in tidal waters)
- Individual 404 Permit Required
- Other Nationwide Permit Required: NWP# _____

Required Actions: List waters of the US permit applies to, location in project and check Best Management Practices planned to control erosion, sedimentation and post-project TSS.

- 1.
- 2.
- 3.
- 4.

The elevation of the ordinary high water marks of any areas requiring work to be performed in the waters of the US requiring the use of a nationwide permit can be found on the Bridge Layouts.

Best Management Practices:

Erosion	Sedimentation	Post-Construction TSS
<input type="checkbox"/> Temporary Vegetation	<input type="checkbox"/> Silt Fence	<input type="checkbox"/> Vegetative Filter Strips
<input type="checkbox"/> Blankets/Matting	<input type="checkbox"/> Rock Berm	<input type="checkbox"/> Retention/Irrigation Systems
<input type="checkbox"/> Mulch	<input type="checkbox"/> Triangular Filter Dike	<input type="checkbox"/> Extended Detention Basin
<input type="checkbox"/> Sodding	<input type="checkbox"/> Sand Bag Berm	<input type="checkbox"/> Constructed Wetlands
<input type="checkbox"/> Interceptor Swale	<input type="checkbox"/> Straw Bale Dike	<input type="checkbox"/> Wet Basin
<input type="checkbox"/> Diversion Dike	<input type="checkbox"/> Brush Berms	<input type="checkbox"/> Erosion Control Compost
<input type="checkbox"/> Erosion Control Compost	<input type="checkbox"/> Erosion Control Compost	<input type="checkbox"/> Mulch Filter Berm and Socks
<input type="checkbox"/> Mulch Filter Berm and Socks	<input type="checkbox"/> Mulch Filter Berm and Socks	<input type="checkbox"/> Compost Filter Berm and Socks
<input type="checkbox"/> Compost Filter Berm and Socks	<input type="checkbox"/> Compost Filter Berm and Socks	<input type="checkbox"/> Vegetation Lined Ditches
	<input type="checkbox"/> Stone Outlet Sediment Traps	<input type="checkbox"/> Sand Filter Systems
	<input type="checkbox"/> Sediment Basins	<input type="checkbox"/> Grassy Swales

III. CULTURAL RESOURCES

Refer to TxDOT Standard Specifications in the event historical issues or archeological artifacts are found during construction. Upon discovery of archeological artifacts (bones, burnt rock, flint, pottery, etc.) cease work in the immediate area and contact the Engineer immediately.

No Action Required Required Action

Action No.

1. No action necessary above those required by the 2004 Texas Standard for Specifications Construction and Maintenance of Highways, Streets, and Bridges.
- 2.
- 3.
- 4.

IV. VEGETATION RESOURCES

Preserve native vegetation to the extent practical. Contractor must adhere to Construction Specification Requirements Specs 162, 164, 192, 193, 506, 730, 751, 752 in order to comply with requirements for invasive species, beneficial landscaping, and tree/brush removal commitments.

No Action Required Required Action

Action No.

1. Contractor to adhere to specifications listed above.
- 2.
- 3.
- 4.

V. FEDERAL LISTED, PROPOSED THREATENED, ENDANGERED SPECIES, CRITICAL HABITAT, STATE LISTED SPECIES, CANDIDATE SPECIES AND MIGRATORY BIRDS.

No Action Required Required Action

Action No.

1. Contractor to adhere to direction concerning migratory birds described below.
- 2.
- 3.
- 4.

If any of the listed species are observed, cease work in the immediate area, do not disturb species or habitat and contact the Engineer immediately. The work may not remove active nests from bridges and other structures during nesting season of the birds associated with the nests. If caves or sinkholes are discovered, cease work in the immediate area, and contact the Engineer immediately.

LIST OF ABBREVIATIONS

BMP: Best Management Practice	SPCC: Spill Prevention Control and Countermeasure
CGP: Construction General Permit	SW3P: Storm Water Pollution Prevention Plan
DSHS: Texas Department of State Health Services	PCN: Pre-Construction Notification
FHWA: Federal Highway Administration	PSL: Project Specific Location
MOA: Memorandum of Agreement	TCEQ: Texas Commission on Environmental Quality
MOU: Memorandum of Understanding	TPDES: Texas Pollutant Discharge Elimination System
MS4: Municipal Separate Stormwater Sewer System	TPWD: Texas Parks and Wildlife Department
MBTA: Migratory Bird Treaty Act	TxDOT: Texas Department of Transportation
NOT: Notice of Termination	T&E: Threatened and Endangered Species
NWP: Nationwide Permit	USACE: U.S. Army Corps of Engineers
NOI: Notice of Intent	USFWS: U.S. Fish and Wildlife Service

VI. HAZARDOUS MATERIALS OR CONTAMINATION ISSUES

General (applies to all projects):

Comply with the Hazard Communication Act (the Act) for personnel who will be working with hazardous materials by conducting safety meetings prior to beginning construction and making workers aware of potential hazards in the workplace. Ensure that all workers are provided with personal protective equipment appropriate for any hazardous materials used. Obtain and keep on-site Material Safety Data Sheets (MSDS) for all hazardous products used on the project, which may include, but are not limited to the following categories: Paints, acids, solvents, asphalt products, chemical additives, fuels and concrete curing compounds or additives. Provide protected storage, off bare ground and covered, for products which may be hazardous. Maintain product labelling as required by the Act.

Maintain an adequate supply of on-site spill response materials, as indicated in the MSDS. In the event of a spill, take actions to mitigate the spill as indicated in the MSDS, in accordance with safe work practices, and contact the District Spill Coordinator immediately. The Contractor shall be responsible for the proper containment and cleanup of all product spills.

Contact the Engineer if any of the following are detected:

- * Dead or distressed vegetation (not identified as normal)
- * Trash piles, drums, canister, barrels, etc.
- * Undesirable smells or odors
- * Evidence of leaching or seepage of substances

Does the project involve any bridge class structure rehabilitation or replacements (bridge class structures not including box culverts)?

Yes No

If "No", then no further action is required.

If "Yes", then TxDOT is responsible for completing asbestos assessment/inspection.

Are the results of the asbestos inspection positive (is asbestos present)?

Yes No

If "Yes", then TxDOT must retain a DSHS licensed asbestos consultant to assist with the notification, develop abatement/mitigation procedures, and perform management activities as necessary. The notification form to DSHS must be postmarked at least 15 working days prior to scheduled demolition.

If "No", then TxDOT is still required to notify DSHS 15 working days prior to any scheduled demolition.

In either case, the Contractor is responsible for providing the date(s) for abatement activities and/or demolition with careful coordination between the Engineer and asbestos consultant in order to minimize construction delays and subsequent claims.

Any other evidence indicating possible hazardous materials or contamination discovered on site. Hazardous Materials or Contamination Issues Specific to this Project:

No Action Required Required Action

Action No.

- 1.
- 2.
- 3.

VII. OTHER ENVIRONMENTAL ISSUES

(includes regional issues such as Edwards Aquifer District, etc.)

No Action Required Required Action

Action No.

- 1.
- 2.
- 3.

 Texas Department of Transportation		<i>Design Division Standard</i>	
ENVIRONMENTAL PERMITS, ISSUES AND COMMITMENTS			
EPIC			
FILE: epic.dgn	DN: TxDOT	CK: RG	DW: VP
© TxDOT: February 2015	CONT	SECT	JOB
12-12-2011 (DS) REVISIONS	0910	16	165
05-07-14 ADDED NOTE SECTION IV.	DIST	COUNTY	SHEET NO.
01-23-2015 SECTION I (CHANGED ITEM 1122 TO ITEM 506, ADDED GRASSY SWALES.	TYL	SMITH	59

DATE: 5/13/2022
 FILE: K:\DAL_TPTO\project\063615008 - Tyler HSIP PS&E\CADD\Standards\MLK Corridor\EC(9)_1-16.dgn
 DISCLAIMER: The use of this standard is governed by the "Texas Engineering Practice Act". No warranty of any kind is made by TxDOT for any purpose whatsoever. TxDOT assumes no responsibility for the conversion of this standard to other formats or for incorrect results or damages resulting from its use.

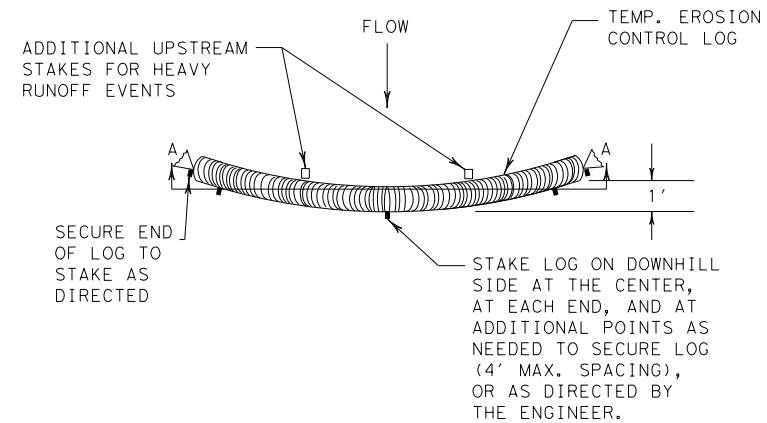

PLAN VIEW

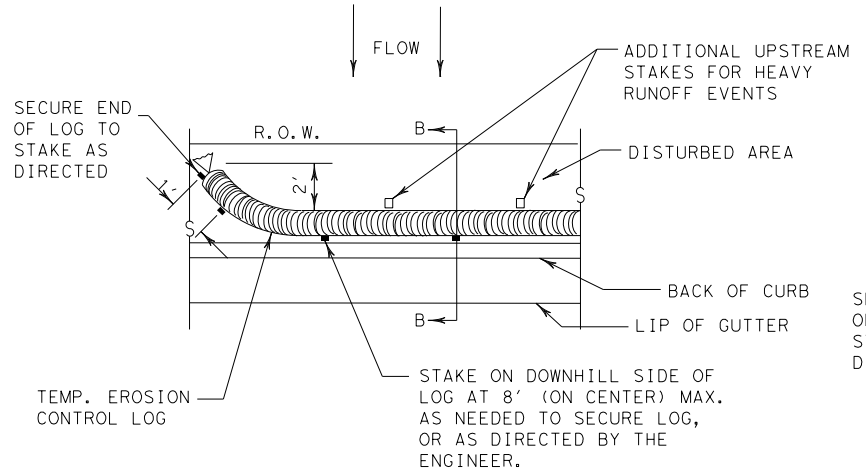

PLAN VIEW

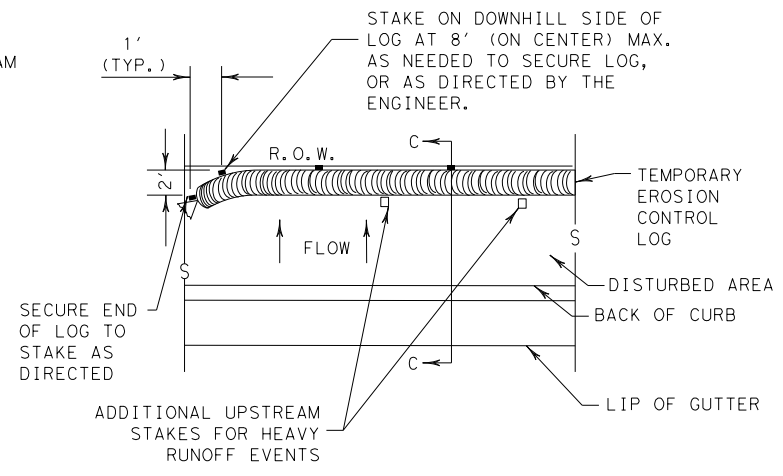

PLAN VIEW

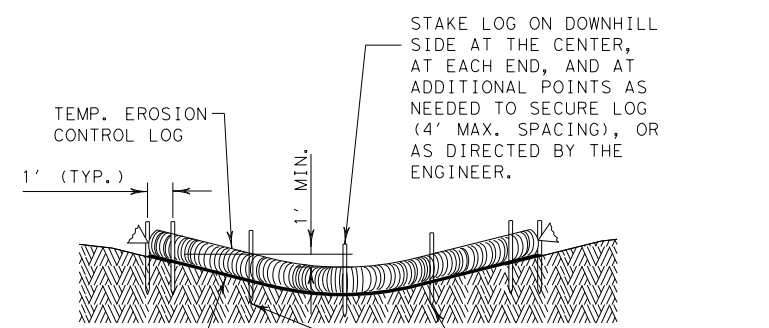

SECTION A-A

EROSION CONTROL LOG DAM

CL-D

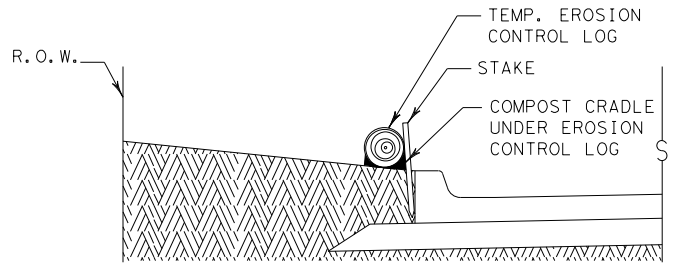

SECTION B-B

EROSION CONTROL LOG AT BACK OF CURB

CL-BOC

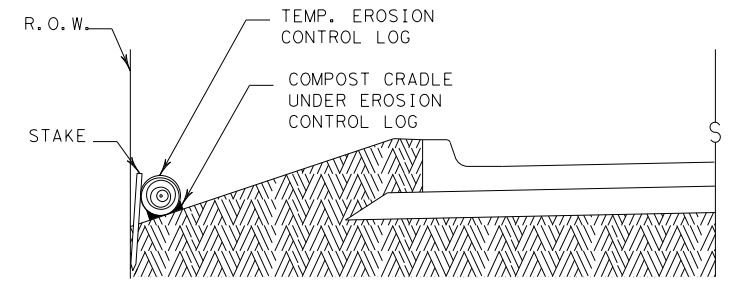

SECTION C-C

EROSION CONTROL LOG AT EDGE OF RIGHT-OF-WAY

CL-ROW

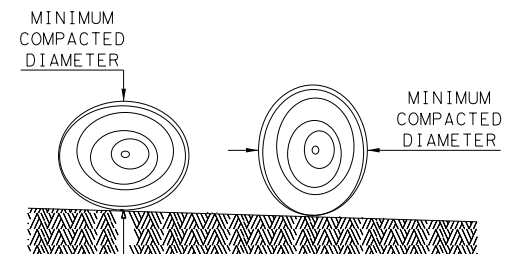

DIAMETER MEASUREMENTS OF EROSION CONTROL LOGS SPECIFIED IN PLANS

- LEGEND
- CL-D EROSION CONTROL LOG DAM
 - CL-BOC EROSION CONTROL LOG AT BACK OF CURB
 - CL-ROW EROSION CONTROL LOG AT EDGE OF RIGHT-OF-WAY
 - CL-SST EROSION CONTROL LOGS ON SLOPES STAKE AND TRENCHING ANCHORING
 - CL-SSL EROSION CONTROL LOGS ON SLOPES STAKE AND LASHING ANCHORING
 - CL-DI EROSION CONTROL LOG AT DROP INLET
 - CL-CI EROSION CONTROL LOG AT CURB INLET
 - CL-GI EROSION CONTROL LOG AT CURB & GRATE INLET

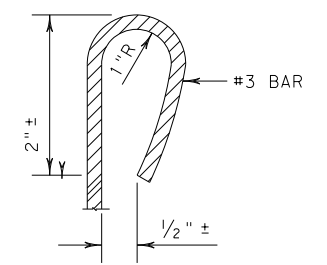

REBAR STAKE DETAIL

SEDIMENT BASIN & TRAP USAGE GUIDELINES

An erosion control log sediment trap may be used to filter sediment out of runoff draining from an unstabilized area.

Log Traps: The drainage area for a sediment trap should not exceed 5 acres. The trap capacity should be 1800 CF/Acre (0.5" over the drainage area).

Control logs should be placed in the following locations:

1. Within drainage ditches spaced as needed or min. 500' on center
2. Immediately preceding ditch inlets or drain inlets
3. Just before the drainage enters a water course
4. Just before the drainage leaves the right of way
5. Just before the drainage leaves the construction limits where drainage flows away from the project.

The logs should be cleaned when the sediment has accumulated to a depth of 1/2 the log diameter.

Cleaning and removal of accumulated sediment deposits is incidental and will not be paid for separately.

- GENERAL NOTES:**
1. EROSION CONTROL LOGS SHALL BE INSTALLED IN ACCORDANCE WITH MANUFACTURER'S RECOMMENDATIONS, OR AS DIRECTED BY THE ENGINEER.
 2. LENGTHS OF EROSION CONTROL LOGS SHALL BE IN ACCORDANCE WITH MANUFACTURER'S RECOMMENDATIONS AND AS REQUIRED FOR THE PURPOSE INTENDED.
 3. UNLESS OTHERWISE DIRECTED, USE BIODEGRADABLE OR PHOTODEGRADABLE CONTAINMENT MESH ONLY WHERE LOG WILL REMAIN IN PLACE AS PART OF A VEGETATIVE SYSTEM. FOR TEMPORARY INSTALLATIONS, USE RECYCLABLE CONTAINMENT MESH.
 4. FILL LOGS WITH SUFFICIENT FILTER MATERIAL TO ACHIEVE THE MINIMUM COMPACTED DIAMETER SPECIFIED IN THE PLANS WITHOUT EXCESSIVE DEFORMATION.
 5. STAKES SHALL BE 2" X 2" WOOD OR #3 REBAR, 2'-4' LONG, EMBEDDED SUCH THAT 2" PROTRUDES ABOVE LOG, OR AS DIRECTED BY THE ENGINEER.
 6. DO NOT PLACE STAKES THROUGH CONTAINMENT MESH.
 7. COMPOST CRADLE MATERIAL IS INCIDENTAL & WILL NOT BE PAID FOR SEPARATELY.
 8. SANDBAGS USED AS ANCHORS SHALL BE PLACED ON TOP OF LOGS & SHALL BE OF SUFFICIENT SIZE TO HOLD LOGS IN PLACE.
 9. TURN THE ENDS OF EACH ROW OF LOGS UPSLOPE TO PREVENT RUNOFF FROM FLOWING AROUND THE LOG.
 10. FOR HEAVY RUNOFF EVENTS, ADDITIONAL UPSTREAM STAKES MAY BE NECESSARY TO KEEP LOG FROM FOLDING IN ON ITSELF.

SHEET 1 OF 3

		Design Division Standard	
TEMPORARY EROSION, SEDIMENT AND WATER POLLUTION CONTROL MEASURES EROSION CONTROL LOG EC(9)-16			
FILE: ec916	DN: TxDOT	CK: KM	DW: LS/PT
© TxDOT: JULY 2016	CONT	SECT	JOB
REVISIONS	0910	16	165
	DIST	COUNTY	SHEET NO.
	TYLER	SMITH	60

DISCLAIMER: The use of this standard is governed by the "Texas Engineering Practice Act". No warranty of any kind is made by TxDOT for any purpose whatsoever. TxDOT assumes no responsibility for the conversion of this standard to other formats or for incorrect results or damages resulting from its use.

DATE: 5/13/2022
 FILE: K:\DAL\TPTON\project\063615008 - Tyler HSIP PS&E\CADD\Standards\MLK Corridor\EC (9) -2-16.dgn

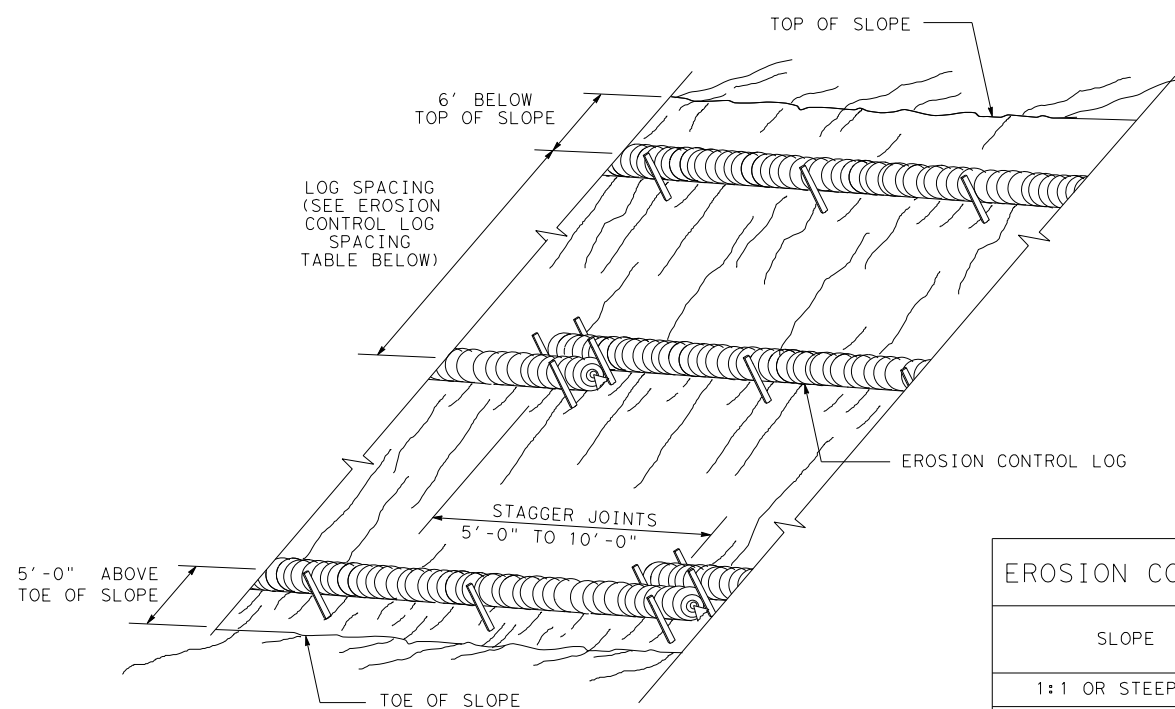

EROSION CONTROL LOGS ON SLOPES
 STAKE AND TRENCHING ANCHORING

CL-SST

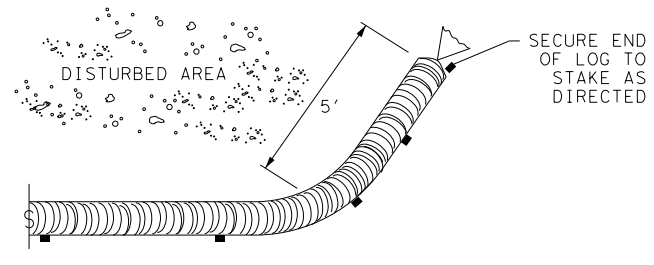

END SECTION RAP DETAIL

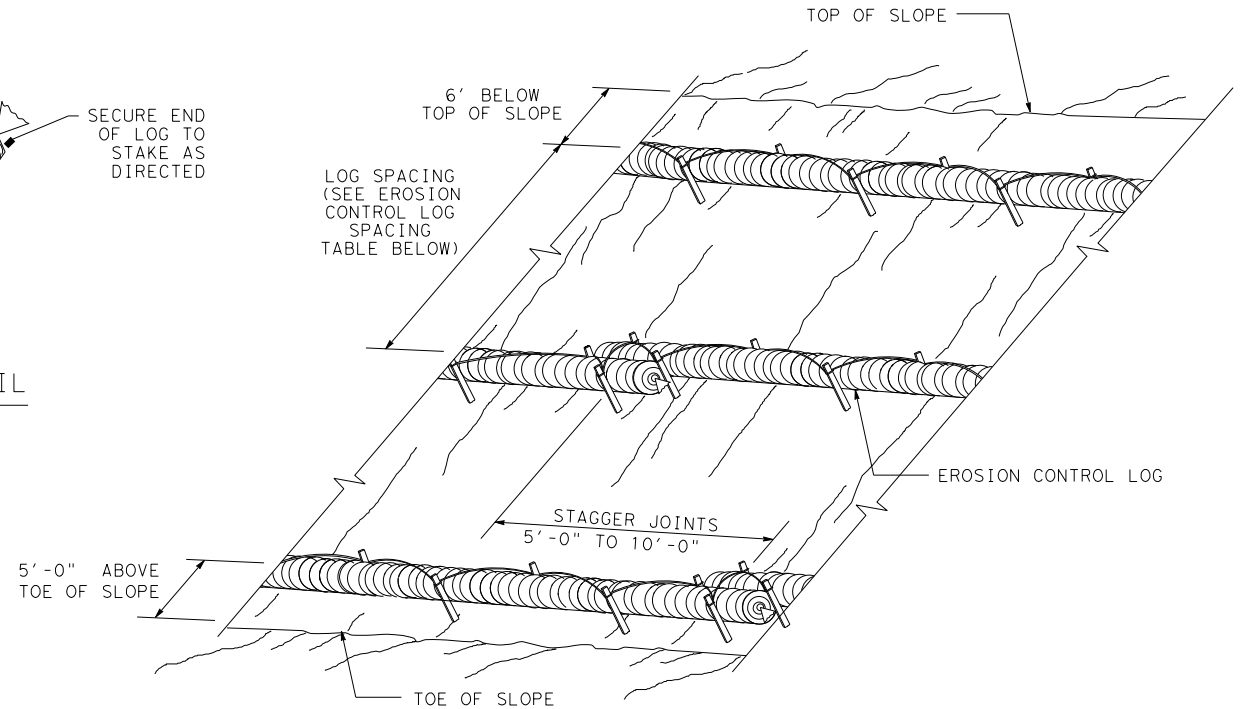

EROSION CONTROL LOGS ON SLOPES
 STAKE AND LASHING ANCHORING

CL-SSL

SLOPE	LOG DIAMETER			
	6"	8"	12"	18"
1:1 OR STEEPER	5'	10'	15'	20'
2:1	10'	20'	30'	40'
3:1	15'	30'	45'	60'
4:1 OR FLATTER	20'	40'	60'	80'

* ADJUSTMENTS CAN BE MADE FOR SOIL TYPE:
 SOFT, LOAMY SOILS-ADJUST ROWS CLOSER TOGETHER;
 HARD, ROCKY SOILS- ADJUST ROWS FARTHER APART

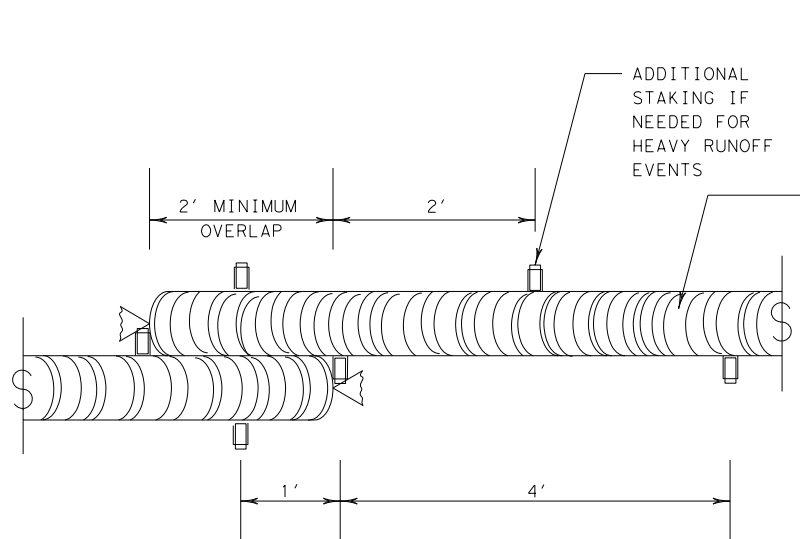

STAKE AND TRENCHING ANCHORING DETAIL

CL-SST

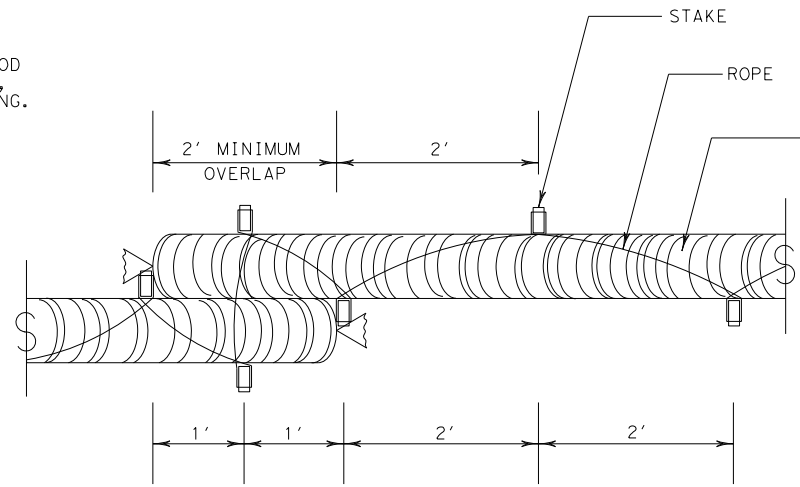
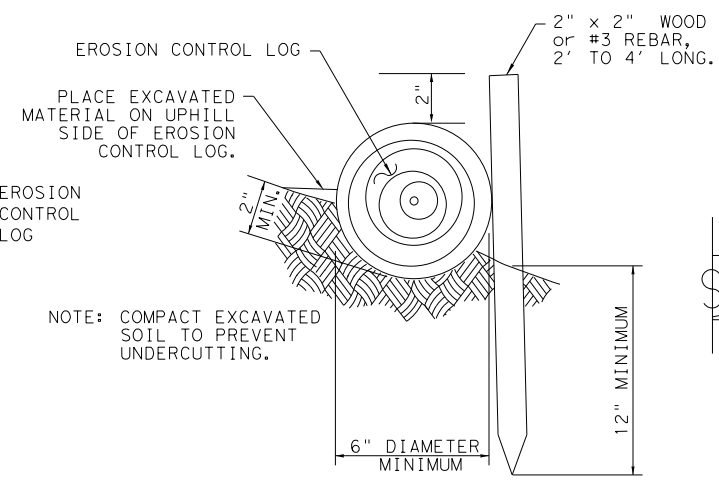

STAKE AND LASHING ANCHORING DETAIL

CL-SSL

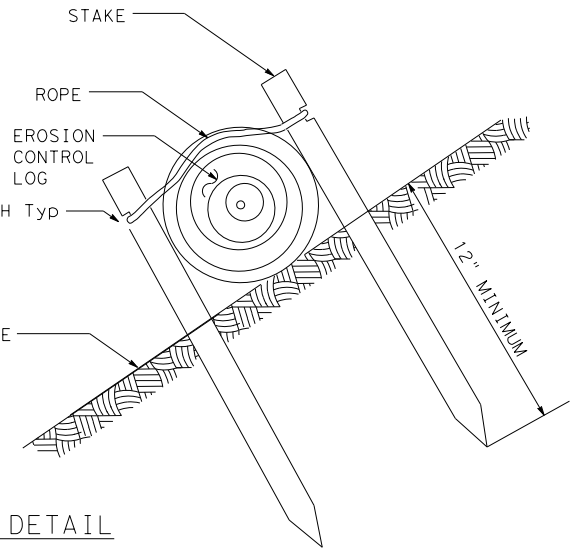

LOG DIAMETER	DEPTH
6"	2"
8"	3"
12"	4"
18"	5"

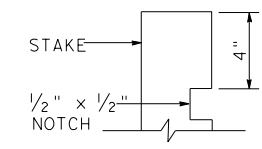

STAKE NOTCH DETAIL

SHEET 2 OF 3

Texas Department of Transportation
 Design Division Standard

TEMPORARY EROSION, SEDIMENT AND WATER POLLUTION CONTROL MEASURES
 EROSION CONTROL LOG
 EC (9) - 16

FILE: ec116	DN: TxDOT	CK: KM	DW: LS/PT	CK: LS
© TxDOT: JULY 2016	CONT	SECT	JOB	HIGHWAY
REVISIONS	0910	16	165	MLK JR
	DIST	COUNTY	SHEET NO.	
	TYLER	SMITH	61	

DATE: 5/13/2022
 FILE: K:\DAL_TPT\project\063615008 - Tyler HSIP PS&E\CADD\Standards\MLK Corridor\EC (9) -3-16.dgn
 DISCLAIMER: The use of this standard is governed by the "Texas Engineering Practice Act". No warranty of any kind is made by TxDOT for any purpose whatsoever. TxDOT assumes no responsibility for the conversion of this standard to other formats or for incorrect results or damages resulting from its use.

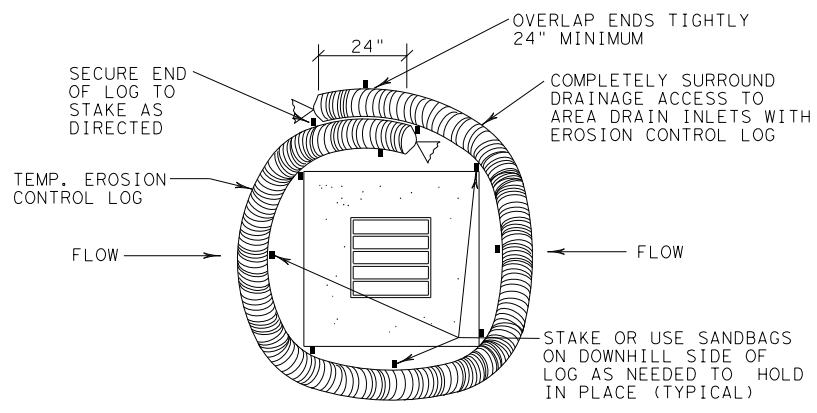

EROSION CONTROL LOG AT DROP INLET

CL-DI

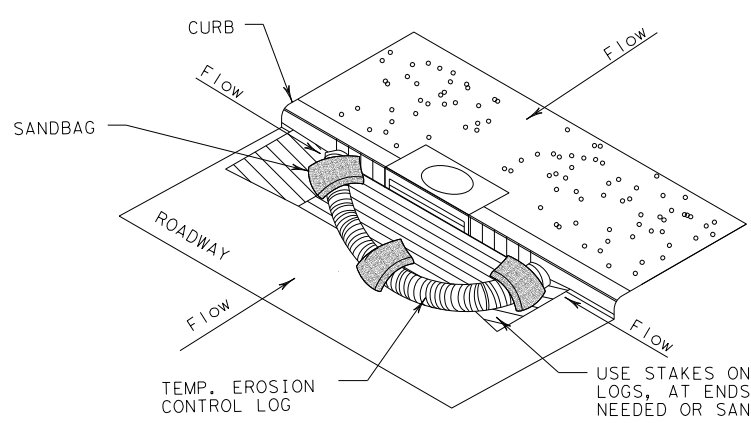

EROSION CONTROL LOG AT CURB INLET

CL-CI

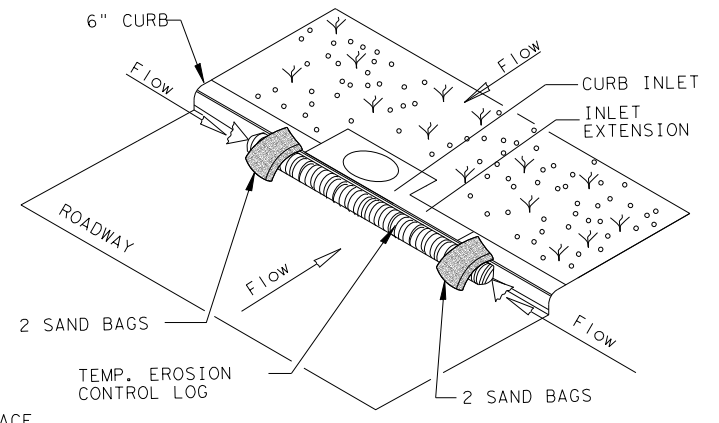

EROSION CONTROL LOG AT CURB INLET

CL-CI

NOTE:
 EROSION CONTROL LOGS USED AT CURB INLETS SHOULD ONLY BE USED IF THEY WILL NOT IMPEDE TRAFFIC OR FLOOD THE ROADWAY OR WHEN THE STORM SEWER SYSTEM IS NOT FULLY FUNCTIONAL.

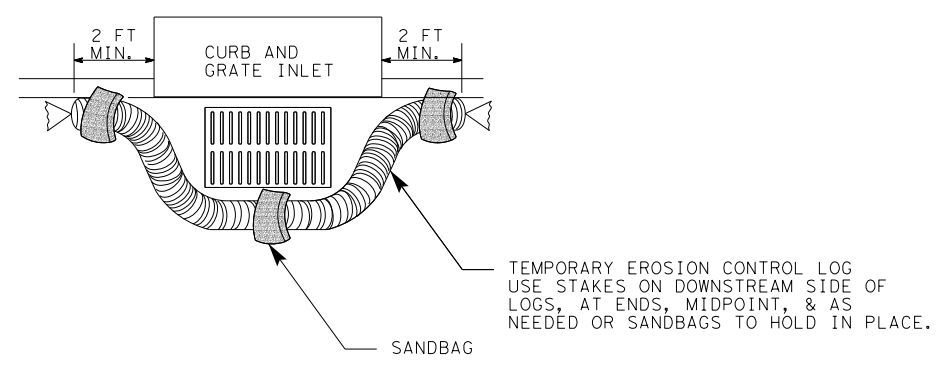

EROSION CONTROL LOG AT CURB & GRADE INLET

CL-GI

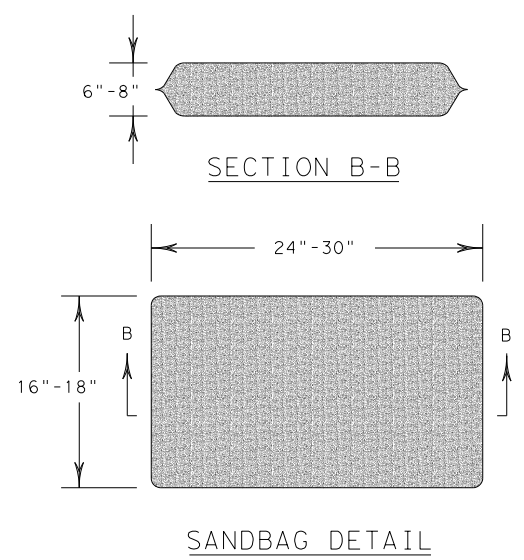

SHEET 3 OF 3

		Design Division Standard	
TEMPORARY EROSION, SEDIMENT AND WATER POLLUTION CONTROL MEASURES EROSION CONTROL LOG EC (9) -16			
FILE: ec916	DN: TxDOT	CK: KM	DW: LS/PT
© TxDOT: JULY 2016	CONT	SECT	JOB
REVISIONS	0910	16	165
	DIST	COUNTY	SHEET NO.
	TYLER	SMITH	62