

FHWA TEXAS DIVISION		SHEET NO. 1	
STATE	DISTRICT	COUNTY	
TEXAS	PAR	HOPKINS, ETC	
CONTROL	SECTION	JOB	HIGHWAY NO.
0083	03	056, ETC	SH 154, ETC

INDEX OF SHEETS
SEE SHEET 2 FOR INDEX OF SHEETS

STATE OF TEXAS DEPARTMENT OF TRANSPORTATION

PLANS OF PROPOSED STATE HIGHWAY IMPROVEMENT

FEDERAL AID PROJECT. STP 2021(409)HES SH 154, ETC. HOPKINS COUNTY, ETC.

NET LENGTH OF PROJECT= VARIOUS

LIMITS: SH 154 FROM SH 11 TO BILL BRADFORD (RADIO RD)
US 69 FROM SH 276 TO FM 2795
SH 11 FROM SH 19 AT FM 2324

TYPE OF WORK: SAFETY RELATED PROJECTS

IMPROVE TRAFFIC SIGNALS, INTERCONNECT SIGNALS,
INSTALL FLASHING BEACON, AND SAFETY LIGHTING.

FINAL PLANS

LETTING DATE: _____
 DATE CONTRACTOR BEGAN WORK: _____
 DATE WORK WAS COMPLETED: _____
 DATE WORK WAS ACCEPTED: _____
 ORIGINAL CONTRACT WORKING DAYS: _____
 USED _____ OF _____ WORKING DAYS
 NO. OF CHANGE ORDERS: _____
 FINAL CONTRACT COST: _____
 PERCENT OVER/UNDER RUN: _____
 CONTRACTOR: _____

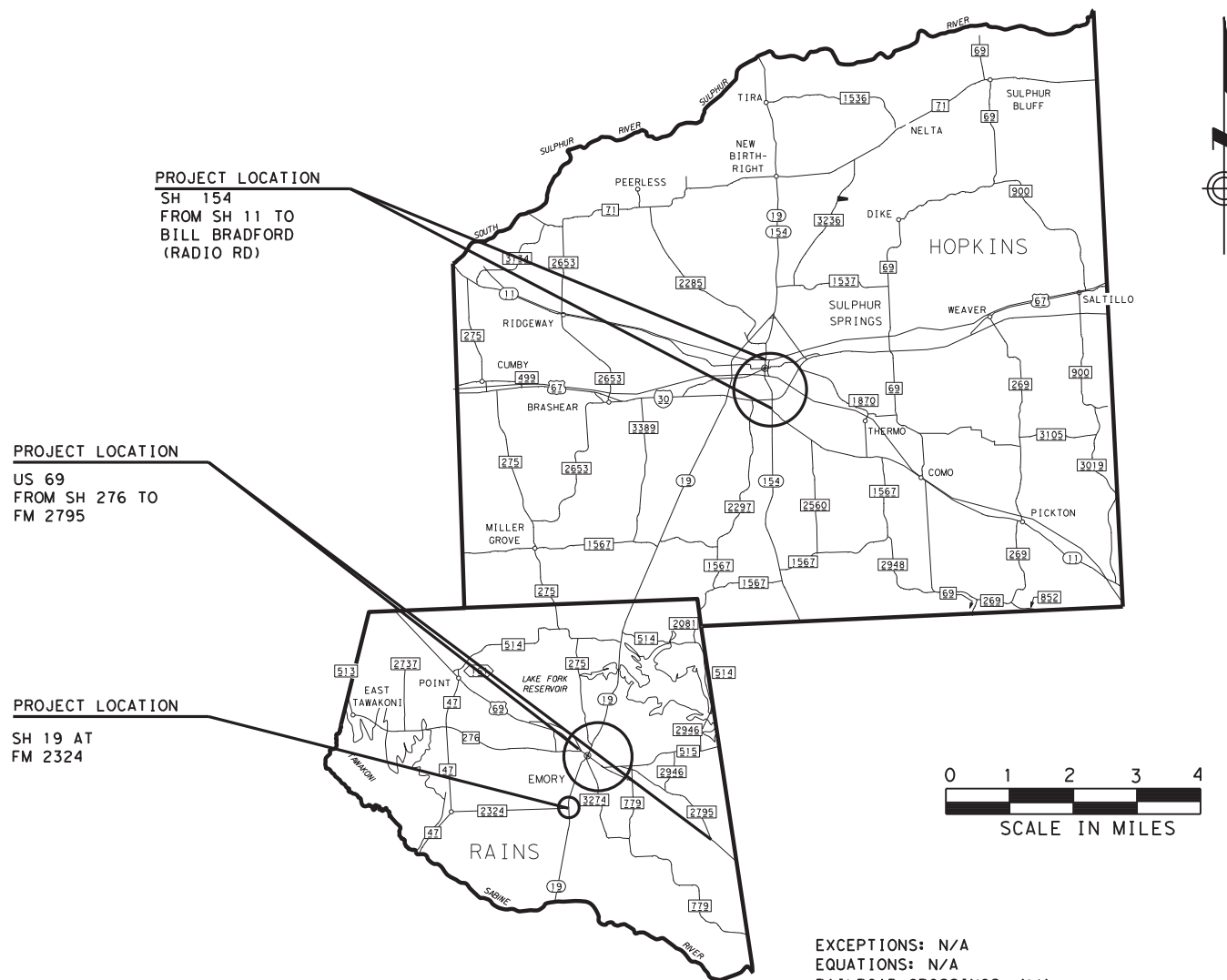

PROJECT LOCATION
SH 154
FROM SH 11 TO
BILL BRADFORD
(RADIO RD)

PROJECT LOCATION
US 69
FROM SH 276 TO
FM 2795

PROJECT LOCATION
SH 19 AT
FM 2324

I CERTIFY THAT THIS PROJECT WAS BUILT IN ACCORDANCE WITH PLANS AND SPECIFICATIONS.

AREA ENGINEER _____ DATE _____

REQUIRED SIGNS SHALL BE IN ACCORDANCE WITH BC (1)- 14 THRU BC (12)- 14 AND THE "TEXAS MANUAL ON UNIFORM TRAFFIC CONTROL DEVICES".



SUBMITTED FOR LETTING: 12/21/2020

DocuSigned by:
Darius Samuels
RA37FC370A7E1E ENGINEER

RECOMMENDED FOR LETTING: 12/21/2020

DocuSigned by:
Jesse Herrera
2FA3E703E3F0A7 ENGINEER

APPROVED FOR LETTING: 12/21/2020

DocuSigned by:
Noel Paramonathan
4E7AF4A4E9F05E ENGINEER

EXCEPTIONS: N/A
EQUATIONS: N/A
RAILROAD CROSSINGS: N/A

© 2021
BY TEXAS DEPARTMENT OF TRANSPORTATION
ALL RIGHTS RESERVED.

SPECIFICATIONS ADOPTED BY THE TEXAS DEPARTMENT OF TRANSPORTATION, NOVEMBER 1, 2014 AND SPECIFICATION ITEMS LISTED AND DATED AS FOLLOWS, SHALL GOVERN ON THIS PROJECT: REQUIRED CONTRACT PROVISIONS FOR ALL FEDERAL-AID CONSTRUCTION CONTRACTS (FORM FHWA 1273, MAY 2012)

FILE: t:\portraf\touasha\esj_0083-03-056 etc.\CSJ_0083-03-056 TITLESHEET.dgn
DATE: 12/4/2020 9:05:35 AM

INDEX OF SHEETS

DWG: _____
 CHK: _____
 DWF: _____
 CDS: _____

<u>SHEET NO.</u>	<u>DESCRIPTION</u>
<u>GENERAL</u>	
1	TITLE SHEET
2	INDEX OF SHEETS
3, 3A-3D	GENERAL NOTES
4, 4A	ESTIMATE & QUANTITY
<u>SH 154</u>	
5	INTERCONNECT AND SIGNAL LAYOUT
6	QUANTITY SUMMARY
<u>US 69</u>	
7	INTERCONNECT AND SIGNAL LAYOUT
8	QUANTITY SUMMARY
<u>SH 19</u>	
9	CONDITION DIAGRAM
10	FLASHING BEACON LAYOUT
11	WIRING DIAGRAM
12	SUMMARY SHEET
13	RIGID METAL CONDUIT SWEEP ELL
14	SIGNAL CONSTRUCTION DETAILS
15	TYPICAL VIRVDS CAMERA MOUNTING DETAILS
16	DETAIL FOR COMMUNICATION EQUIPMENT

<u>SHEET NO.</u>	<u>DESCRIPTION</u>
<u>STANDARDS</u>	
17	> SP-80(1)-12
18	> SP-80(2)-12
19	> TS-BP-20
20	> TS-FD-12
21	> LUM-A-12
22	> RID(1)-17
23	> ITS(6)-15
24	> ED(1)-14
25	> ED(3)-14
26	> ED(4)-14
27	> ED(5)-14
28	> ED(6)-14
29	> ED(7)-14
30	> ED(8)-14
31	> ED(9)-14
32	> WZIBTS-1)-13
33	> WZIBTS-2)-13
34	> BC (1)-14
35	> BC (2)-14
36	> BC (3)-14
37	> BC (4)-14
38	> BC (5)-14
39	> BC (6)-14
40	> BC (7)-14
41	> BC (8)-14
42	> BC (9)-14
43	> BC (10)-14
44	> BC (11)-14
45	> BC (12)-14
46	> EC(1)-16
47	EPIC
48	SW3P

DATE: 12/4/2020 9:05:39 AM
 FILE: t:\portraf\tausho\csj_0083-03-056 etc.\INDEX OF SHEETS.dgn

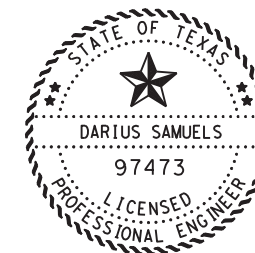

THE STANDARD SHEETS SPECIFICALLY IDENTIFIED WITH A " > " HAVE BEEN ISSUED BY ME AND ARE APPLICABLE TO THIS PROJECT.

12/16/2020
 NAME _____ DATE _____

SH 154, ETC. INDEX OF SHEETS



CONT	SECT	JOB	HIGHWAY
0083	03	056	SH 154, ETC
DIST	COUNTY		SHEET NO.
PAR	HOPKINS, ETC		2

County: HOPKINS, ETC.

Control: 0083-03-056, ETC.

Highway: SH 154, ETC.

Sheet:

GENERAL NOTES

General:

Install Flashing Beacon, Battery Backup Unit (BBU), CCTV Field Equipment (Digital), and Video Imaging and Radar Vehicle Detection System (VIRVDS) in accordance with the current Texas Manual on Uniform Traffic Control Devices and the current National Electrical Code unless otherwise specified on the plans.

Contractor questions on this project are to be addressed to the following individual(s):

Sulphur Springs Area Office

Jesse D Herrera - Jesse.Herrera@txdot.gov

Dustin C Lyday - Dustin.Lyday@txdot.gov

Contractor questions will be accepted through email, phone, and in person by the above individuals.

All contractor questions will be reviewed by the Engineer. Once a response is developed, it will be posted to TxDOT's Public FTP at the following Address:

[https://ftp.dot.state.tx.us/pub/txdot-info/Pre-Letting Responses/](https://ftp.dot.state.tx.us/pub/txdot-info/Pre-Letting%20Responses/)

All questions submitted that generate a response will be posted through this site. The site is organized by District, Project Type (Construction or Maintenance), Letting Date, CCSJ/Project Name.

Dispose of waste materials at an approved site. Furnish written approval from the property owner before disposal of waste materials.

Locate equipment a minimum of 30 feet from roadway when possible. Place signs and barricades as approved.

Stockpile sites for construction materials must be approved. Give at least 48 hours notification prior to stockpiling material.

Item 2 Instructions to Bidders:

View plans on-line or download from the web at:

<http://www.txdot.gov/business/letting-bids/plans-online.html>

Order plans from any of the plan reproduction companies shown on the web at:

<http://www.txdot.gov/business/letting-bids/repro-companies.html>

Item 5 Control of the Work:

The responsibility for the construction surveying on this contract will be in accordance with Section 5.9.3, Method C.

Item 7 Legal Relations and Responsibilities:

No significant traffic generator events identified.

County: HOPKINS, ETC.

Control: 0083-03-056, ETC.

Highway: SH 154, ETC.

Sheet: 3

Item 8 Prosecution and Progress:

Before beginning work on this project submit in writing, for approval, a plan of construction operations outlining in detail a sequence of work to be followed.

Provide a Bar Chart progress schedule for this project.

This project includes SP 008---003 which allows up to a 90-day delay to begin work on the project to acquire materials such as traffic signal poles and Video Equipment.

Working days will be computed and charged in accordance with Article 8.3.1.4 Standard Work Week.

Item 9 Measurement and Payment:

Items of work for the Monthly Estimate will be cut off on the 25th of each month. Items of work performed after the 25th will be processed and paid on the following month's estimate. Material On Hand (MOH) will cut off on the 20th of each month. Special circumstances will be considered on a case by case basis.

Maintain all new signal equipment on the project until accepted by TxDOT.

Item 416 Drill shaft foundations:

The locations shown on the plans for pole foundations are approximate. Achieve the correct signal head placement and clearance before drilling and pouring pole foundations. Extend all pole foundations at least ten feet below ground.

Dispose of all excavated material off right-of-way at an approved location.

Item 502 Barricades, Signs and Traffic Handling:

The Contractor Force Account "Safety Contingency" that has been established for this project is intended to be utilized for work zone enhancements, to improve the effectiveness of the Traffic Control Plan, that could not be foreseen in the project planning and design stage. These enhancements will be mutually agreed upon by the Engineer and the Contractor's Responsible Person based on weekly or more frequent traffic management reviews on the project. The Engineer may choose to use existing bid items if it does not slow the implementation of enhancement.

All flaggers are required to wear a white hard hat while performing flagging operations.

The traffic control plan for this contract consists of the installation and maintenance of warning signs and other traffic control devices shown in the plans, specification data which may be included in the general notes, applicable provisions of the Texas Manual on Uniform Traffic Control Devices (TMUTCD), traffic control plan sheets included in the plans, standard BC sheets and Item 502 of the Standard Specifications.

Do not begin Item 502, Barricades, Signs, and Traffic Handling, on the roadway until both of the following conditions are met:

County: HOPKINS, ETC.

Control: 0083-03-056, ETC.

Highway: SH 154, ETC.

Sheet:

1. The work schedule is approved.
2. No more than 5 workdays will pass between the beginning of Item 502 and the actual commencement of roadway work bid items.

The final estimate will be withheld until all disturbed areas are covered with at least 70% perennial vegetative cover.

Correct all deficiencies within the time frame noted on the Traffic Control Device Inspection Form 599. Failure to make corrections within time frame specified may result in no payment for this Item for the month of the noted deficiency.

Signing and traffic control for traffic signal work is in accordance with standard sheets WZ (BTS-1)-13, WZ (BTS-2)-13, BC (1)-14 thru BC (12)-14, and the current Texas Manual on Uniform Traffic Control Devices. Use major street Traffic Control on all approaches.

Furnish and place portable 48" x 48" stop signs with an all way placard at the intersection when signal is placed in flash or power is off. Portable signs will not be paid for directly but will be considered subsidiary to various bid items. All signing must be approved by the Engineer before work begins.

The standard sheets WZ (BTS-1)-13 and WZ (BTS-2)-13 govern when they conflict with BC (1)-14 – BC (12)-14 sheets.

Cover all signal heads with satisfactory material specified or point down when not in operation.

Furnish a phone number reachable 24 hours a day. Be available to return call within two hours.

Ensure that all travel lanes are open at night.

Item 506 Temporary Erosion, Sedimentation & Environmental Controls:

It is the intent of this contract that no disturbance of vegetation occurs as a result of the roadway operations. However, if vegetation is disturbed, treat the disturbed area as follows at no additional costs to the department.

Place temporary sediment control fence, or an alternative material as approved, to minimize and control the amount of sediment that might enter receiving waters from the disturbed area(s). Maintain the sediment controls in a satisfactory manner until the disturbed area(s) is stabilized. After the area(s) has been stabilized, remove the sediment controls. The location and length of the sediment controls will be determined.

The work performed, materials furnished, equipment, labor, tools, and incidentals will not be measured or paid for directly, but will be considered subsidiary to the various bid items.

Item 618 Conduit

Use rigid metal sweep ells for all conduits entering the controller base.

County: HOPKINS, ETC.

Control: 0083-03-056, ETC.

Highway: SH 154, ETC.

Sheet: 3A

Rigid metallic conduit elbows that are required to be installed on conduit system will not be paid for directly but will be considered subsidiary to the various bid items.

Where the rigid metal conduit is exposed at any point, and where rigid metal conduit extends into ground boxes, bond the metal conduit to the grounding conductor with grounding type bushings or by other UL listed grounding connectors as approved.

Attach all conduits to any type pole with conduit straps spaced at maximum intervals of five feet and within three feet of each side of any enclosure.

Provide boring equipment capable of tracking location and depth of bore head at all times. Bore head must be able to change bore direction without removing bore head. Mark depth of conduit at ten feet intervals along the length of bore and provide a copy of depth and location information.

Make all threaded conduit and conduit fittings wrench tight.

Shore pits for jacking or boring conduit when closer than five feet to the back of the curb. Consider shoring subsidiary to this item.

Maintain a minimum vertical cover of 24 inches on all conduits except when it crosses flow line at which point it is a minimum of 36 inches. Maximum depth of sweep ells will be 36 inches unless otherwise shown.

Item 620 Electric Conductor:

Install a continuous #6 AWG XHHW green ground wire throughout the traffic signal system. Bond grounding conductors that share the same conduit, junction box, ground box or structure at every accessible point in accordance with the current National Electric Code and TxDOT Standard Sheets.

Item 621 Tray Cable

Identify luminaire wiring at the fuse holder in the pole base as to line side, load side, and luminaire number.

Label tray Cable in the load center within 2 inches of termination as to what they serve.(FB A, FB C, ILLUM A, ILLUM B, etc.)

Item 628 Electrical services

Install according to utility company requirements. Coordinate service with Engineer.

County: HOPKINS, ETC.

Control: 0083-03-056, ETC.

Highway: SH 154, ETC.

Sheet:

Item 680 Installation of Highway Traffic Signals

Send all signal related material submittals to District Traffic Operations for approval.

Use pre-qualified materials and products from the TxDOT "Material Producer List" on the TxDOT website.

The below materials will be supplied by the Department. Install as shown on the plans or as directed by engineer.

MATERIAL FURNISHED BY STATE			
CSJ	TRAFFIC SIGNAL CONTROLLER (EA)	BLUETOOTH READER (EA)	FLASHER CABINET(EA)
0083-03-056	4	4	
0203-03-049	3	3	
0108-11-021			1

All signal control equipment furnished has been shop tested. The contractor must sign for the equipment received from TxDOT Signal Shop.

Electrical licenses and certifications for this project will be as per Item 7 of the current Texas Standard Specifications and any special provisions to Item 7.

Furnish all materials and repair any sod, pavement, sidewalk, or other property damaged during the course of the construction, this is according to Article 7.15 of the standard specification.

Ensure that all materials furnished are corrosion resistant and exhibit no rust.

Verify actual location of utilities and take adequate precautions to prevent damage to utilities, storm sewers, and existing signal equipment.
Return removed material to TxDOT unless otherwise approved by engineer.

Pick up all TxDOT furnished equipment at one time at the District Signal Shop located at 1365 North Main Street in Paris for the intersection location. Assume responsibility for all such equipment until final acceptance of the project.

After all signal construction is complete, all circuits are checked, and the signal is ready to turn on, District Transportation Operation are notified and will perform a preliminary check of all signal plan details. Prepare all field wiring inside the controller cabinet for termination prior to this inspection. When the signal installation is complete, all safety related items on the punch list are completed, place in normal operation, this will start the thirty day test period.

County: HOPKINS, ETC.

Control: 0083-03-056, ETC.

Highway: SH 154, ETC.

Sheet: 3B

Item 682 Vehicle and Pedestrian Signal Heads

Mount vehicle heads vertical except where noted on plans.

Mount signal heads so that the bottom of the head is between eighteen and nineteen feet above the pavement surface. Mount at the same elevation when there are two or more heads on the same support.

Mount each signal head plumb and aim parallel with the lane it is controlling, unless otherwise directed.

Adjust the location of signal heads as needed so that one head does not block the view of another head.

Item 684 Traffic Signal Cable

Expose no cables unless shown on plans.

Do not strip back the outer jacket of Type A signal cable entering the head until it is inside the signal head. Terminate all field wiring in the bottom section of the signal head.

Strip back the outer jacket of Type A signal cable to within two inches above conduit in the controller cabinet.

Leave an extra length of five feet coiled in the controller cabinet for each cable run to the controller cabinet.

Label all cables going to signal heads in the hand hole according to phase, direction and position (ex: 02 NB RT). Label field wiring terminated in the cabinet within two inches of termination by phase and direction.

Tie together and bond all wires in pole access compartments colored solid green to pole ground.

All exposed cables shown on plans have a drip loop of two or more five to six-inch diameter turns.

Test conductors for continuity. Reject any conductor testing more than ten-ohms resistance.

Item 686 Traffic Signal Pole Assemblies (Steel)

Plug all holes in signal poles and mast arms with metal plugs or caps colored to match poles. Replace terminal strips with marathon type strips and fuse blocks.

Item 6004 Networking Intelligent Transportation System (ITS) Communications Cable

Communication cable shall consist of Cat 5e or Cat 6 as called for in the plans. The cable shall be rated for outdoor direct burial, shielded, and gel filled or with waterblock tape as approved by Engineer. The estimated length shown on plans is subsidiary to Item 6010 and/or Item 6062.

County: HOPKINS, ETC.

Control: 0083-03-056, ETC.

Highway: SH 154, ETC.

Sheet:

Item 6010 Closed Circuit Television (CCTV) Field Equipment

The CCTV Camera (ITS HD PTZ camera) shall be a high performance 1/2.8-in. progressive scan day/night CMOS sensor with up to 1920 x 1080 resolution with a 30x optical zoom lens and a 12x digital zoom, produce a color image with a minimum scene illumination of 0.0077 lux and a monochrome image when in the night mode with a minimum illumination of 0.0008 lux at 30 IRE, comply with the IK10 impact rating and with the IP68 and TYPE 6P environmental protection rating, provide direct network connection using H.264, H.265 and JPEG compression and bandwidth throttling to efficiently manage bandwidth, have embedded video analysis (VA) that process and analyze video within the camera that eliminates dedicated PCs and associated software maintenance, conform to the ONVIF standard to provide interoperability, offer configurable quad streaming with individually configurable HD streams, be able to control optional illuminator to produce white light to capture full scene details in color and produce 850m IR array to allow detection of objects at a maximum distance of 450m, be the most recent version of the product at time of purchase.

Each camera shall include a power assembly consisting of (1) Microsemi PD-9501GI/DC Poe (1) Phoenix Contact Power Supply Unit 2902993-UNO=PS/1AC/24DC/100w (1) Phoenix Contact Surge Protection Device 2881007 –DT-LAN-Cat.6+, all necessary parts to pole mount the camera, and any other parts needed to install as directed by engineer.

Example: Bosch MIC 7000I PTZ Starlight Camera

Four (4) Bosch UML-554-90 55-inch UHD (4K) LED monitor (3840 x 2160 resolution, DP, HDMI, DVI, VGA inputs, audio, remote, desktop stand, ST650 tilt wall mount, suitable for 24/7 operation), and any other items need to complete system setup.

Install CCTV as shown on plans or as directed by engineer. If mounting location is less than 30 feet high use two astro clamps (AB 3040-84-SS-PNC) installed at the top of the pole with a minimum of 16 feet of 2" galvanized TWT (Thin Wall Tubing) to attach CCTV or approved by engineer. No training required.

Item 6062 Intelligent Transportation System (ITS) Radio

Install Encom E-Lite 450 INT Dual (or approved equal) – IEEE 802.11a/n/ac dual 5.8Ghz radio with 23 DBI or greater integrated dual polarity panel antenna, two external type n female connectors, two 3-meter LMR-400 cables, one external dual polarity panel antenna, Ethernet cable from POE to radio, POE device, and any other material required for proper operation.

Install new radio on pole where CCTV is located or location approved by engineer.

Removal of existing radio and cables is subsidiary to the installation of this item.

Item 6058 Battery Backup System (BBU)

Install battery backup system as called for and, in a manner, as directed by Engineer. The BBU enclosure shall have an external locking generator access door with a L5-30 F1 plug, be a minimum of 21" wide, and include a remote battery management system (example Myers MP2000E-TBE UPS, PTS-722535-G

County: HOPKINS, ETC.

Control: 0083-03-056, ETC.

Highway: SH 154, ETC.

Sheet: 3C

PTS/MBPS with generator option, and ICBM Battery Manager Kit for 48v 1 string in a minimum 21" wide cabinet or equal).

Cat 5e cable shall be installed to connect the BBU to the switch in the signal cabinet and any wire/material needed to connect existing service conductors to the BBU and back to the signal cabinet are to be installed and are considered subsidiary to the pay item.

Item 6083 Video Imaging and Radar Vehicle Detection System (VIRVDS)

Leave an extra 5 ft. of cable inside controller cabinet. Secure the drip loop using cable ties suitable for outdoor use. Seal VIRVDS cable ends at all times to prevent moisture contamination. Identify VIRVDS communications cable runs by color tape on both ends of the runs and at hand holes. Use different color tape for each run.

Detection areas are in accordance to TTI guidelines (or as directed by engineer). Detection zones shown on plans are for informational purposes only.

Furnish documentation as to how the detection zones are setup, (example: where the detector is mapped to, how the detection cards are identified, if there are any extends or delays on the detection zones or in the VIRVDS system, etc.)

The VIRVDS system will transmit and receive all information needed for detection setup, monitoring vehicle detection while viewing traffic flow and interrogating all required stored data. This information will be accessible at any remote location by any new or existing computer that has Windows 10 Professional software.

Provide an Ethernet device in the controller cabinet for remote communications with each VIRVDS system. Communications with VIRVDS will be made by Ethernet connection with no additional hardware. The system shall display 4 camera views simultaneously with overlays on each camera view without having to select another camera view. The system will view video with detection zones overlaid on the same field of view including radar operations while monitoring actual operation, during setup and while editing detection zones.

Minimum signal cabinet VIRVDS monitor size is 10".

A managed Ethernet switch shall be included with each VIRVDS system and is considered subsidiary to ITEM 6083. The switch shall consist of a minimum of eight 10/100 Ethernet ports and two gigabit ports (8+2G) and shall be an all-in-one firewall/NAT/VPN/router/switch (example MOXA EDR-810-VPN-2GSFP or equal) as well as any other equipment needed for remote communication.

Any items not specifically listed in the table below or described in the General notes needed for connection and communication will be required and are considered subsidiary to ITEM 6083.

County: HOPKINS, ETC.

Control: 0083-03-056, ETC.

Highway: SH 154, ETC.

Sheet:

Required Items for Item 6083:

Description	Not Required	Required
Central Control Workstation (Described in General Notes)	X	
TS-2 interface		X
Camera adjustment. Furnish adjustment module. (1 per project)	X	
Field Communications Link Cat5e as specified by manufacture		X
System Set-Up: Video Monitor with interface software (1 for each intersection)		X
Field setup computer (Tablet as described in General Notes.) (1- per project)		X
Operation from Control. System will transmit and receive all information needed for detector setup, monitor the vehicle detection, view the vehicle traffic flow and interrogate all required stored data from any desktop or laptop that has the operating software on it.		X

Field setup computer (12" Rugged Tablet) must meet the following minimum requirements:

Intel Core i7-8650U Processor

16 GB 1866MHz LPDDR3 Memory

M.2 512 GB PCIe NVMe Class 40 Opal 2.0 SED Drive

Active Pen for 12" Rugged Tablet

Desktop Dock for 12" Rugged Tablet

Keyboard Cover with Kickstand for Rugged Tablet

Intel 8265 Wi-Fi + BT 4.2 Wireless Card (2x2)

2-cell (34Wh) Lithium Ion Primary Battery

2-cell (34Wh) Lithium Ion Secondary Battery

45-Watt AC Adaptor

Battery Charger for Rugged Tablet

Windows 10 Professional 64bit with Recovery USB

WLAN Chassis 11.6 FHD Outdoor-Readable Glove-Capable Touchscreen w/Gorilla Glass

County: HOPKINS, ETC.

Control: 0083-03-056, ETC.

Highway: SH 154, ETC.

Sheet: 3D

Micro Serial Port

USB to Serial (9 pin) Adaptor

USB to Ethernet Adaptor

Field setup computer configuration will be submitted to the District Signal Shop to verify it meets the minimum requirements prior to purchase and the computer to be provided at the start of construction.

Supply Iteris Vantage Next Video Imaging and Radar Vehicle Detection system (VIRVDS) with SPM as one unit in accordance with Item 6083 and includes but not limited to:

Location	Vector camera/radar units	Vantage Next shelf-mount CCU's	10" Color Monitors	Cat5e Cable as specified by manufacture and as shown (LF) *	System Set-up
SH 154 AT BILL BRADFORD RD	4	1	1	600	1
SH 154 AT LEE	4	1	1	600	1
SH 154 AT IH 30	6	2	1	1500	1
SH 154 AT SH 11	4	1	1	700	1
US 69 AT SH 276	4	1	1	800	1

*Length is estimated.

Install VIRVDS cameras directly to the mast arm in accordance with the details shown in the plans and shall be capable of monitoring 3 to 4 lanes of oncoming traffic.

Removal of video equipment and cables is subsidiary to the installation of this item.

The VIRVDS will be tested in a typical intersection application.

Provide ample personnel, equipment and any necessary incidentals to perform testing for detection accuracy, count and flow rate accuracy, speed accuracy, occupancy accuracy and classification accuracy of the VIRVDS in accordance with this item and as directed by the Engineer.

Estimate Sheet

ESTIMATE SUMMARY															
						CONTROL 0083-03-056, ETC SH 154		A L T	ITEM CODE			DESCRIPTION	UNIT	TOTAL	
EST	FINAL	EST	FINAL	EST	FINAL	EST	FINAL		ITEM CODE	DESC CODE	SP NO			EST	FINAL
						1.000			100	6011		PREPARING ROW(TREE)(24" TO 36" DIA.)	EA	1.000	
						24.000			416	6032		DRILL SHAFT (TRF SIG POLE) (36 IN)	LF	24.000	
						1.000			500	6001		MOBILIZATION	LS	1.000	
						3.000			502	6001	008	BARRICADES, SIGNS AND TRAFFIC HANDLING	MO	3.000	
						50.000			506	6038	002	TEMP SEDMT CONT FENCE (INSTALL)	LF	50.000	
						50.000			506	6039	002	TEMP SEDMT CONT FENCE (REMOVE)	LF	50.000	
						8.000			610	6102		REPLACE LUMINAIRE W/LED (250W EQ)	EA	8.000	
						283.000			621	6002		TRAY CABLE (3 CONDR) (12 AWG)	LF	283.000	
						1.000			628	6119		ELC SRV TY D 120/240 060(NS)AL(E)TS(O)	EA	1.000	
						1.000			680	6001	006	INSTALL HWY TRF SIG (FLASH BEACON)	EA	1.000	
						4.000			682	6003		VEH SIG SEC (12")LED(YEL)	EA	4.000	
						4.000			682	6005		VEH SIG SEC (12")LED(RED)	EA	4.000	
						104.000			684	6008		TRF SIG CBL (TY A)(12 AWG)(3 CONDR)	LF	104.000	
						2.000			686	6020		INS TRF SIG PL AM (S)STR(TY D)LUM	EA	2.000	
						7.000			6010	6002		CCTV FIELD EQUIPMENT (DIGITAL)	EA	7.000	
						7.000			6010	6004		CCTV MOUNT (POLE)	EA	7.000	
						7.000			6058	6001		BBU SYSTEM (EXTERNAL BATT CABINET)	EA	7.000	
						7.000			6062	6034		ITS RADIO (DUAL)(5 GHZ/5 GHZ)-I-U	EA	7.000	
						5.000			6083	6001		VIDEO IMAGING AND RAD VEH DETECTION SYS	EA	5.000	
						7.000			6146	6001		INSTALLATION OF BLUETOOTH READER	EA	7.000	
												MATERIAL FURNISHED BY THE STATE			
												TRAFFIC SIGNAL CONTROLLER	LS	1.000	
												MATERIAL FURNISHED BY THE STATE			
												BLUETOOTH READER	LS	1.000	
												CONTRACTOR FORCE ACCOUNT WORK (PARTICIP			
												EROSION CONTROL MAINTENANCE CONTRACTOR	LS	1.000	
												CONTRACTOR FORCE ACCOUNT WORK (PARTICIP			
												SAFETY CONTINGENCY CONTRACTOR FORCE AC	LS	1.000	
												STATE FORCE ACCOUNT WORK			
												SIGNAL TECHNICIAN CHARGES	LS	1.000	
												MATERIAL FURNISHED BY THE STATE			
												FLASHER CABINET	LS	1.000	
												STATE FORCE ACCOUNT WORK			
												SIGNAL TECHNICIAN CHARGES	LS	1.000	
												MATERIAL FURNISHED BY THE STATE			
												TRAFFIC SIGNAL CONTROLLER	LS	1.000	
												MATERIAL FURNISHED BY THE STATE			
												BLUETOOTH READER	LS	1.000	









Estimate Sheet

ESTIMATE SUMMARY																
						CONTROL 0083-03-056, ETC SH 154		A L T	ITEM CODE			DESCRIPTION	UNIT	TOTAL		
EST	FINAL	EST	FINAL	EST	FINAL	EST	FINAL		ITEM CODE	DESC CODE	SP NO			EST	FINAL	
													STATE FORCE ACCOUNT WORK			
													SIGNAL TECHNICIAN CHARGES	LS	1.000	

ESTIMATE & QUANTITY SHEET

DIST	COUNTY	CCSJ	SHEET
01	HOPKINS, ETC	0083-03-056, ETC	4A

LEGEND

-  TRAFFIC CONTROLLER GROUND MOUNTED
-  TRAFFIC SIGNAL POLE
-  TRAFFIC CONTROLLER ON SIGNAL POLE
-  SERVICE POLE
-  PEDESTAL SERVICE
-  RADIO
-  CCTV
-  PED DETECTION PUSH BUTTON (APS)
-  BBU (EXTERNAL BATTERY CABINET)

* REPLACE VIVDS WITH VIRVDS (VIDEO IMAGING AND RAD VEH DETECTION).

SULPHUR SPRINGS

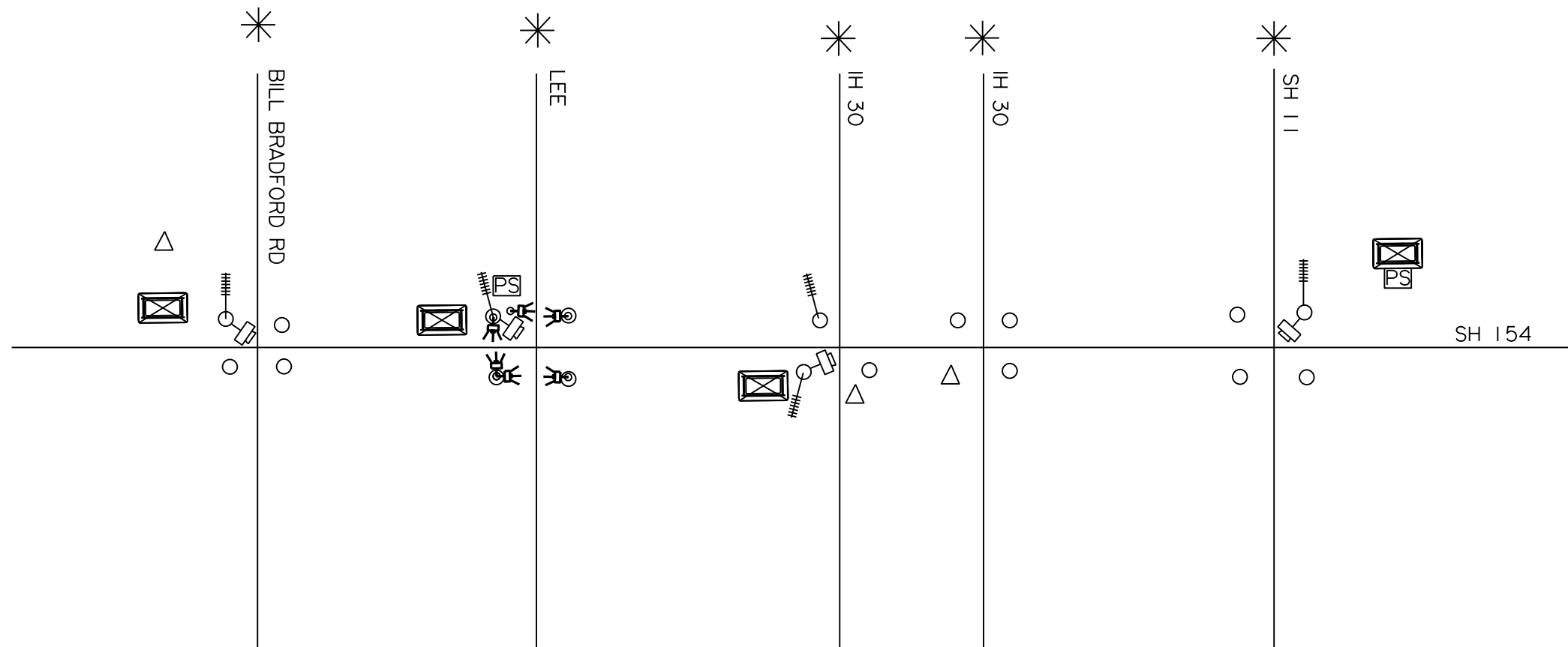

REFER TO QUANTITY SUMMARY FOR EQUIPMENT TO INSTALL.

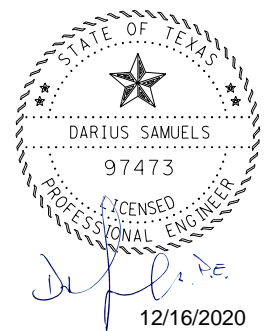

**INTERCONNECT
AND SIGNAL
LAYOUT
SH 154
0083-03-056**

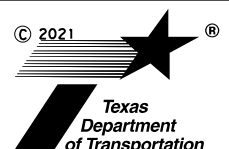
© 2021 

CONT	SECT	JOB	HIGHWAY
0083	03	056	SH 154, ETC
DIST	COUNTY		SHEET NO.
PAR	HOPKINS, ETC		5

NOT TO SCALE

INTERCONNECT SUMMARY FOR SH 154								
ITEM NO	DESC CODE	DESCRIPTION	UNIT	BILL BRADFORD	LEE	IH 30	SH 11	TOTAL
	**	ITS COMM CBL (ETHERNET)	LF	300	300	300	300	1200
6010	6002	CCTV FIELD EQUIPMENT (DIGITAL)	EA	1	1	1	1	4
6010	6004	CCTV MOUNT (POLE)	EA	1	1	1	1	4
6058	6001	BBU SYSTEM (EXTERNAL BATT CABINET)	EA	1	1	1	1	4
6062	6034	ITS RADIO (DUAL)(5 GHZ/5 GHZ)-I-U	EA	1	1	1	1	4
6083	6001	VIDEO IMAGING AND RAD VEH DETECTION SY	EA	1	1	1	1	4
6146	6001	INSTALLATION OF BLUETOOTH READER	LF	1	1	1	1	4

** ESTIMATED LENGTH IS SUBSIDIARY TO ITEM 6010 AND/OR ITEM 6062.

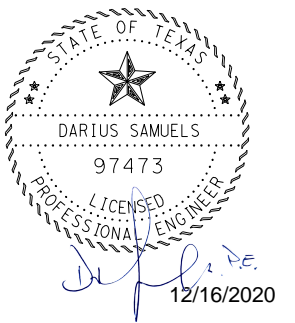



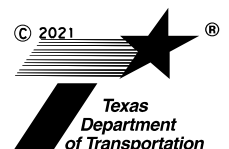





**QUANTITY
SUMMARY
SH 154
0083-03-056**

© 2021  [®]

Texas
Department
of Transportation

CONT	SECT	JOB	HIGHWAY
0083	03	056	SH 154, ETC
DIST	COUNTY		SHEET NO.
PAR	HOPKINS, ETC		6

LEGEND

-  TRAFFIC CONTROLLER GROUND MOUNTED
-  TRAFFIC SIGNAL POLE
-  TRAFFIC CONTROLLER ON SIGNAL POLE
-  SERVICE POLE
-  PEDESTAL SERVICE
-  RADIO
-  CCTV
-  PED DETECTION PUSH BUTTON (APS)
-  BBU (EXTERNAL BATTERY CABINET)

* REPLACE VIVDS WITH VIRVDS (VIDEO IMAGING AND RAD VEH DETECTION).

EMORY

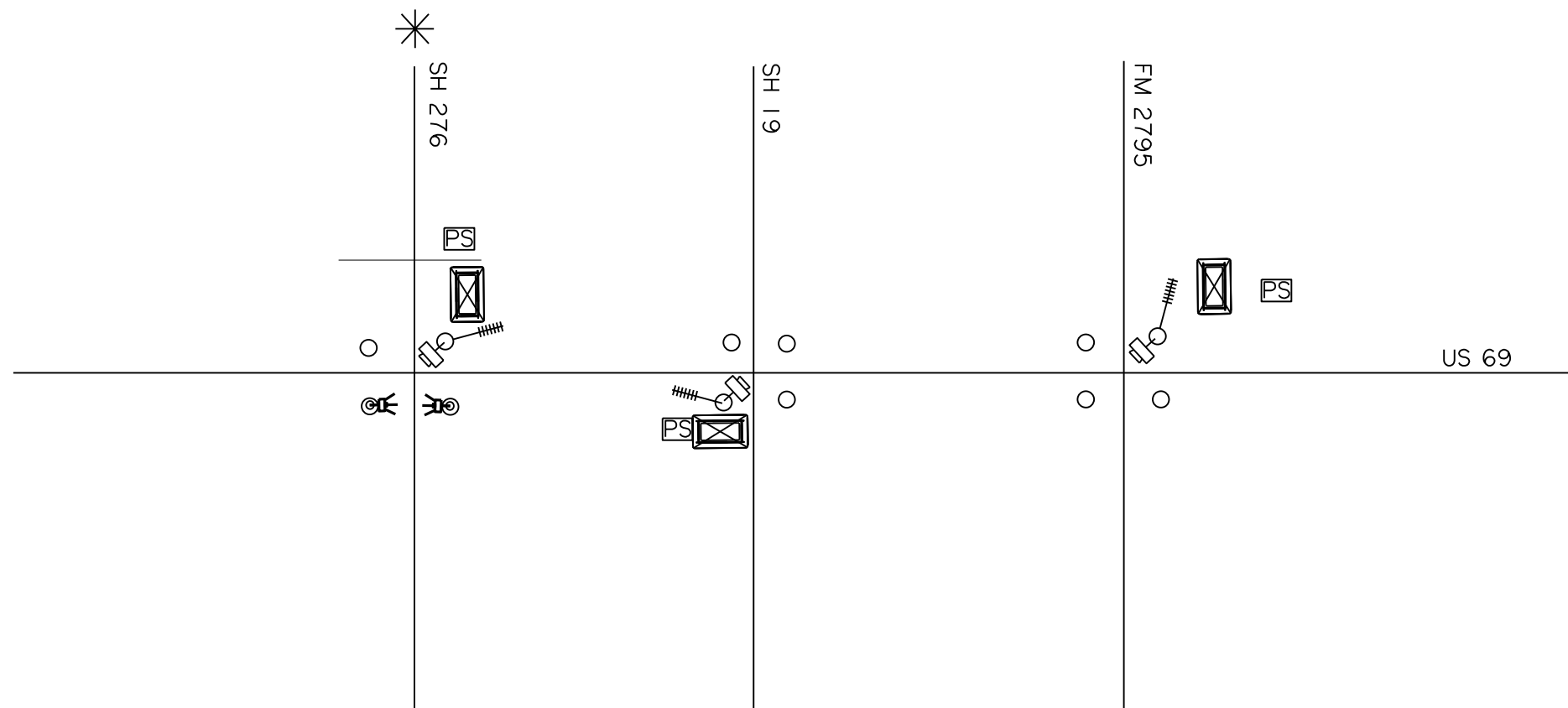

REFER TO QUANTITY SUMMARY FOR EQUIPMENT TO INSTALL.

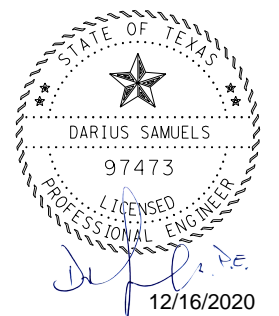

**INTERCONNECT
AND SIGNAL
LAYOUT
US 69
0203-03-049**

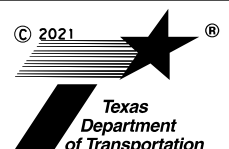
© 2021 

CONT	SECT	JOB	HIGHWAY
0083	03	056	SH 154, ETC
DIST	COUNTY		SHEET NO.
PAR	HOPKINS, ETC		7

NOT TO SCALE

INTERCONNECT SUMMARY FOR US 69							
ITEM NO	DESC CODE	DESCRIPTION	UNIT	SH 276	SH 19	FM 2795	TOTAL
610	6102	REPLACE LUMINAIRE W/LED (250W EQ)	EA	2	4	2	8
	**	ITS COMM CBL (ETHERNET)	LF	300	150	450	900
6010	6002	CCTV FIELD EQUIPMENT (DIGITAL)	EA	1	1	1	3
6010	6004	CCTV MOUNT (POLE)	EA	1	1	1	3
6058	6001	BBU SYSTEM (EXTERNAL BATT CABINET)	EA	1	1	1	3
6062	6034	ITS RADIO (DUAL)(5 GHZ/5 GHZ)-I-U	EA	1	1	1	3
6083	6001	VIDEO IMAGING AND RAD VEH DETECTION SY	EA	1			1
6146	6001	INSTALLATION OF BLUETOOTH READER	LF	1	1	1	3

** ESTIMATED LENGTH IS SUBSIDIARY TO ITEM 6010 AND/OR ITEM 6062.

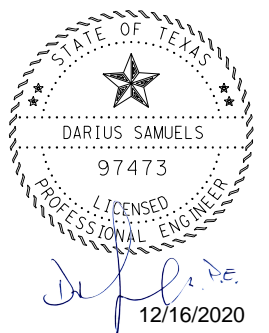

**QUANTITY
SUMMARY
US 69
0203-03-049**

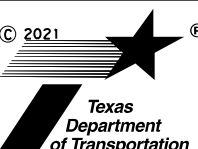
© 2021  [®]

Texas
Department
of Transportation

CONT	SECT	JOB	HIGHWAY
0083	03	056	SH 154, ETC
DIST	COUNTY		SHEET NO.
PAR	HOPKINS, ETC		8

DATE:
FILE:

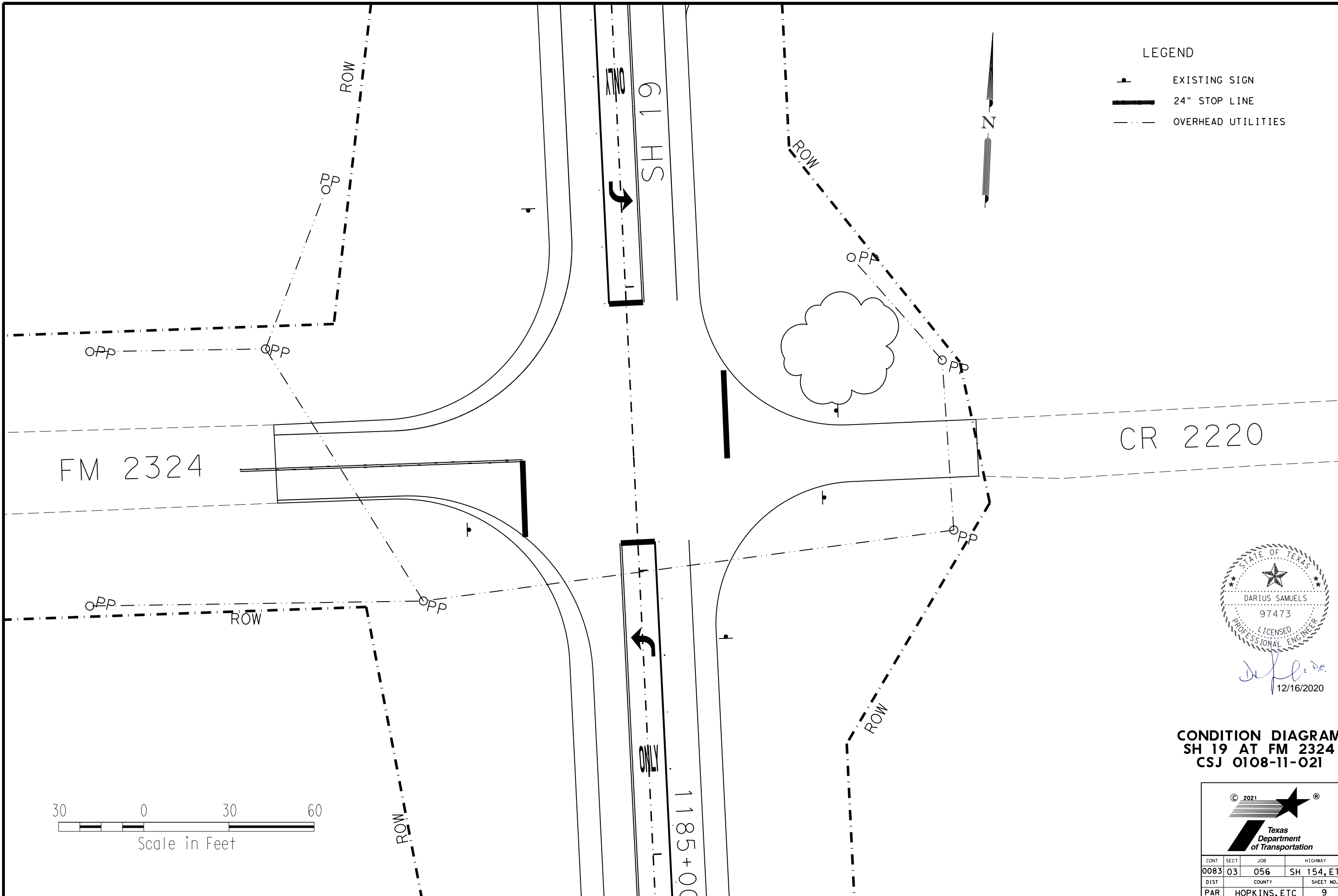

LEGEND

- EXISTING SIGN
- 24" STOP LINE
- OVERHEAD UTILITIES

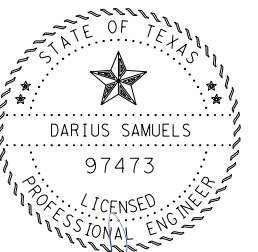





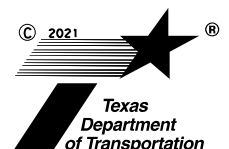



Darius Samuels
12/16/2020

CONDITION DIAGRAM
SH 19 AT FM 2324
CSJ 0108-11-021

© 2021 			
CONT	SECT	JOB	HIGHWAY
0083	03	056	SH 154, ETC
DIST	COUNTY		SHEET NO.
PAR	HOPKINS, ETC		9

LEGEND

-  FLASHING BEACON CONTROLLER
-  EXISTING SIGN
-  FLASHING BEACON
-  STRAIN POLE
-  24" STOP LINE
-  LUMINAIRE
-  OVERHEAD UTILITIES
-  ANCHOR BOLT ORIENTATION

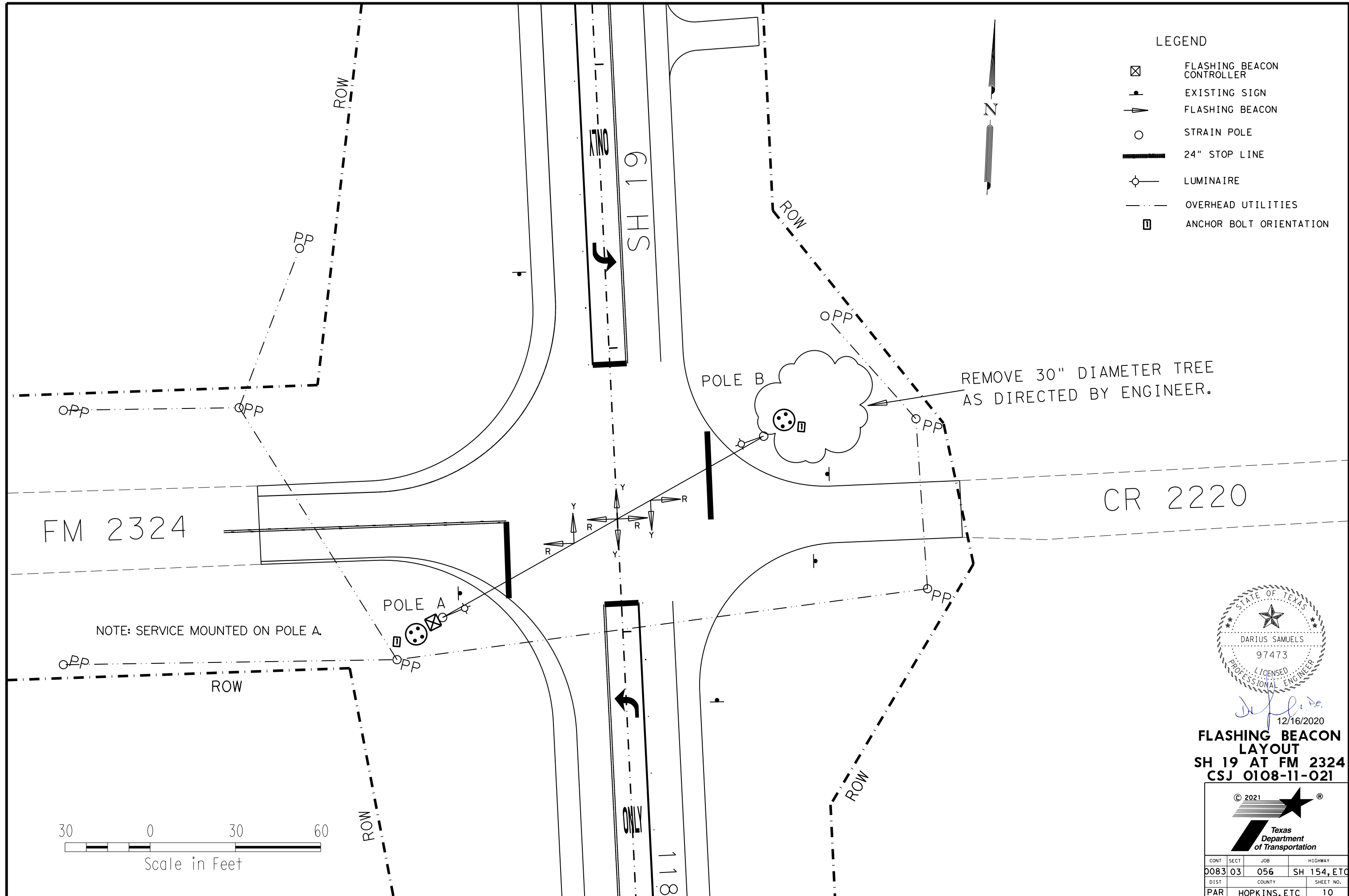

CR 2220

FM 2324

SH 19

NOTE: SERVICE MOUNTED ON POLE A.

REMOVE 30" DIAMETER TREE AS DIRECTED BY ENGINEER.

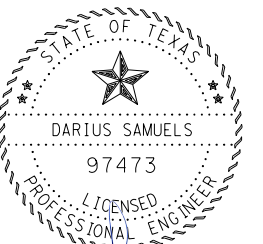

Darius Samuels
12/16/2020

FLASHING BEACON LAYOUT
SH 19 AT FM 2324
CSJ 0108-11-021

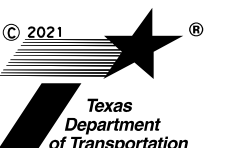

DATE:
FILE:

CONT	SECT	JOB	HIGHWAY
0083	03	056	SH 154, ETC
DIST	COUNTY	SHEET NO.	
PAR	HOPKINS, ETC	10	

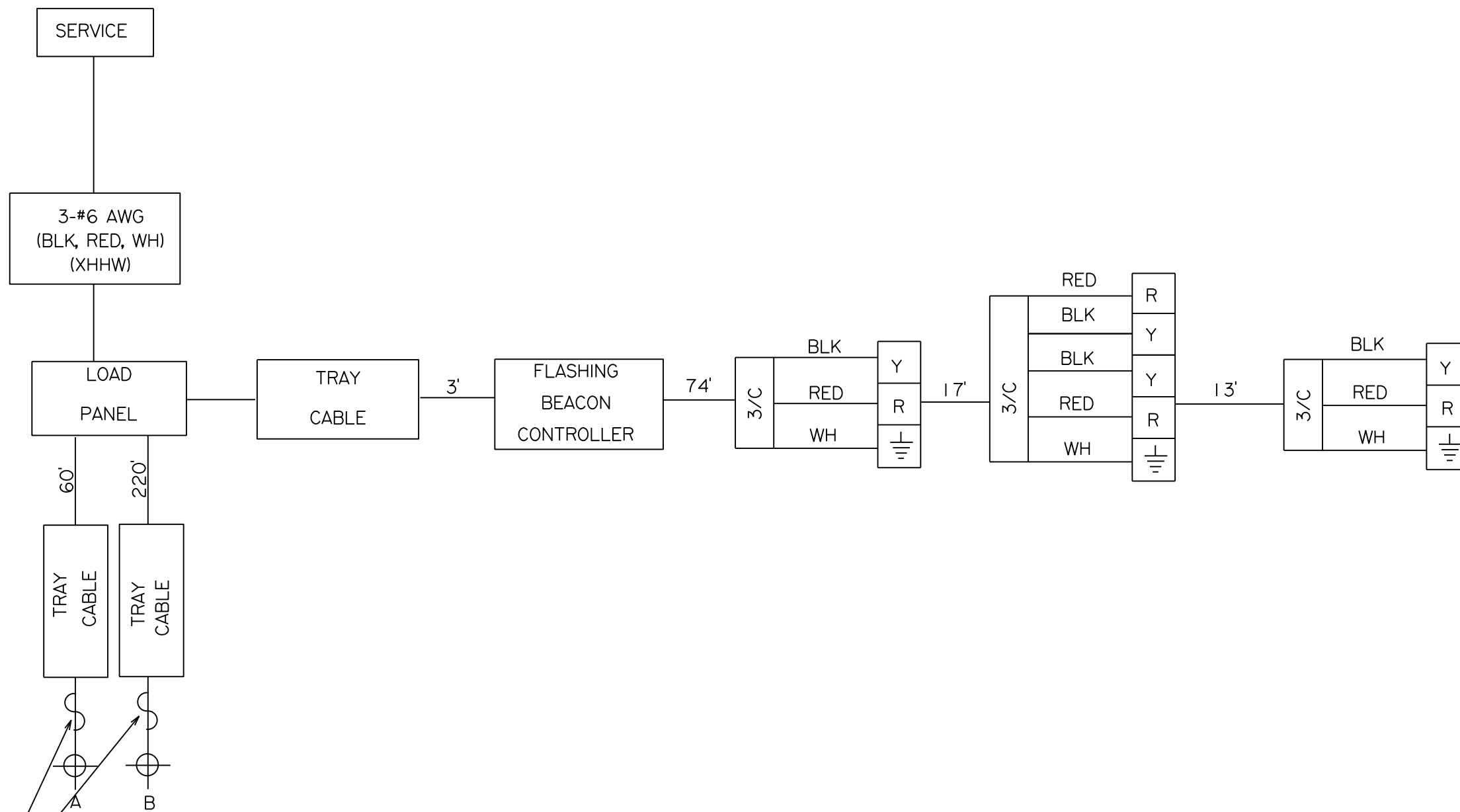

APPROVED _____
 FUSED CONNECTOR-
 LOCATED IN HAND HOLE
 LUMINAIRE IS MOUNTED ON.

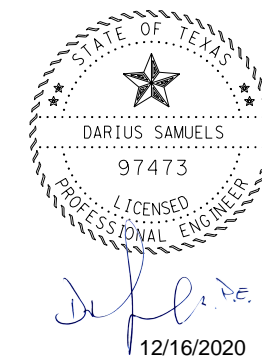

WIRING DIAGRAM
SH 19 AT FM 2324
CSJ 0108-11-021

© 2021 Texas Department of Transportation

CONT	SECT	JOB	HIGHWAY
0083	03	056	SH 154, ETC
DIST	COUNTY	SHEET NO.	
PAR	HOPKINS, ETC	11	

ELECTRICAL SERVICE DATA

ELECTRICAL SERVICE DESCRIPTION (SEE ED(4) (5))	SERVICE CONDUIT SIZE (RMC)	SERVICE CONDUCTORS NO./SIZE	SAFETY SWITCH AMPS	MAIN DISCONNECT		TWO-POLE CONTACTOR AMPS	PANELBD./LOADCENTER AMP RATING (MIN)	CIRCUIT NO.	BRANCH CKT. BRK. POLE/AMPS	KVA LOAD
				SWITCH AMP/FUSES	CKT. BRK. POLE/AMP					
628 6119 ELC SRV TY D 120/240 060(NS)AL(E)TS(O)	2"	SUPPLIED BY OTHERS	N/A	N/A	2P/60	30	100	F.B. Luminaire	1P/15 1P/15	<1.0 <1.0

POLE ASSEMBLY SUMMARY

ITEM NO.	DESC CODE	DESCRIPTION	POLE NO.	UNIT	QUANTITY
686	6020	INS TRF SIG PL AM(S)STR(TY D) LUM	A	EA	1
686	6020	INS TRF SIG PL AM(S)STR(TY D) LUM	B	EA	1

CONDUCTORS AND TRAFFIC SIGNAL CABLE SUMMARY

ITEM NO.	DESC CODE	DESCRIPTION	UNIT	QUANTITY
621	6002	TRAY CABLE (3 COND) (12 AWG)	LF	283
684	6008	TRF SIG CBL (TY A) (12 AWG) (3 CONDR)	LF	104

FLASHING BEACON SUMMARY

ITEM NO.	DESC CODE	DESCRIPTION	UNIT	QUANTITY
416	6032	DRILL SHAFT (TRF SIG POLE) (36 IN)	LF	24
680	6001	INSTAL OF HWY TRAF SIG(FLASH BEACON)	EA	1

DRILL SHAFT POLE A-14 LF AND POLE B-10 LF

SIGNAL HEAD SUMMARY

ITEM NO.	DESC CODE	DESCRIPTION	UNIT	QUANTITY
682	6003	VEH SIG SEC (12")LED(YEL)	EA	4
682	6005	VEH SIG SEC (12")LED(RED)	EA	4

MISCELLANEOUS ITEMS

ITEM NO.	DESC CODE	DESCRIPTION	UNIT	QUANTITY
506	6038	TEMP SEDMT CONT FENCE (INSTALL)	LF	50
506	6039	TEMP SEDMT CONT FENCE (REMOVE)	LF	50
100	6011	PREPARING ROW(TREE) (24" TO 36" DIA.)	EA	1

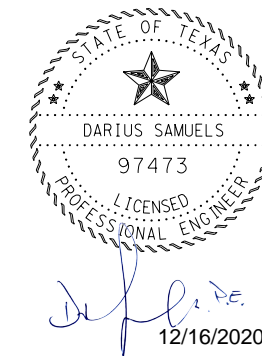

SUMMARY SHEET
SH 19 AT FM 2324
CSJ 0108-11-021

© 2021 [®]

Texas
Department
of Transportation

CONT	SECT	JOB	HIGHWAY
0083	03	056	SH 154, ETC
DIST	COUNTY	SHEET NO.	
PAR	HOPKINS, ETC	12	

DATE: 12/15/2020 4:53:55 PM
FILE: t:\pdr\trf\tausho\csj_0083-03-056 etc.\SH19\FM2324\SH19 @ FM 2324.dgn

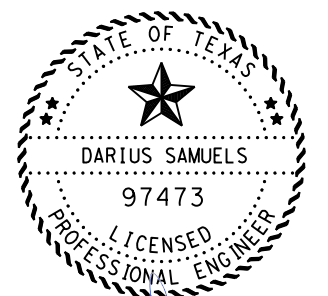
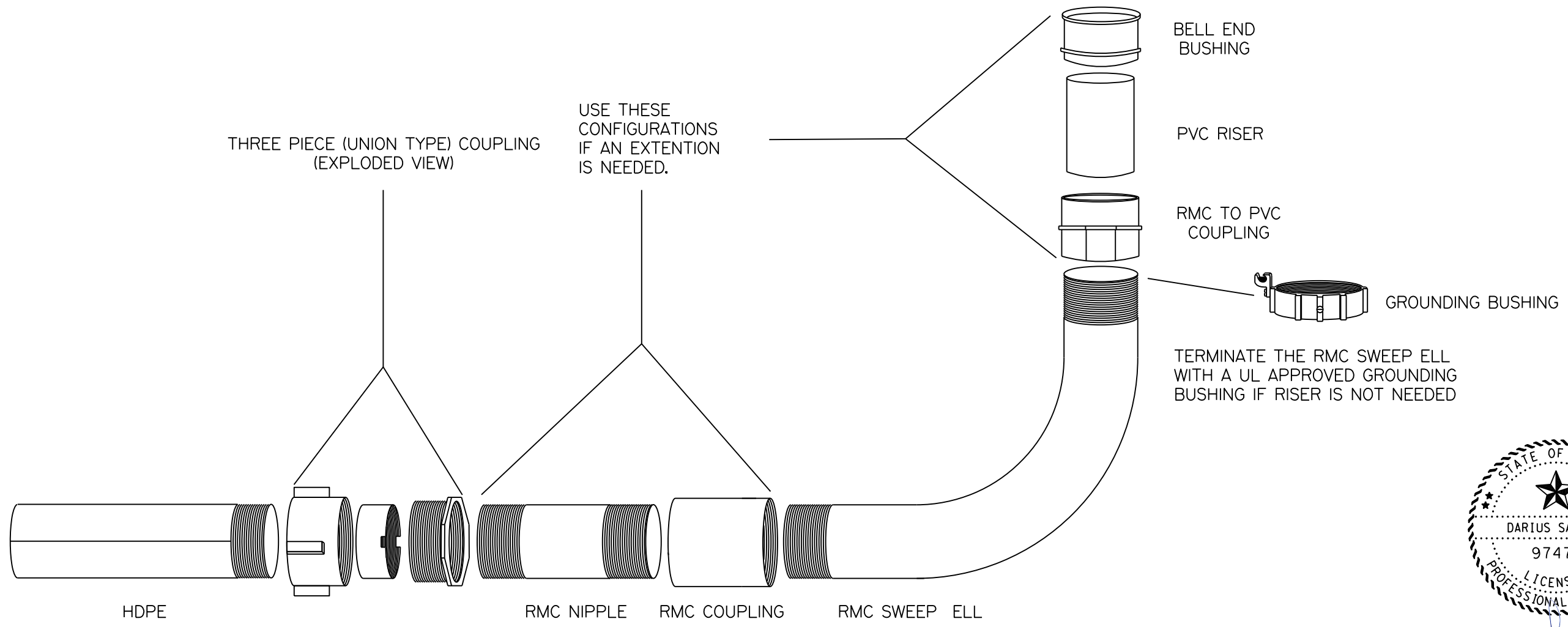

Darius Samuels
12/18/2020

RIGID METAL CONDUIT SWEEP ELL

NOT TO SCALE

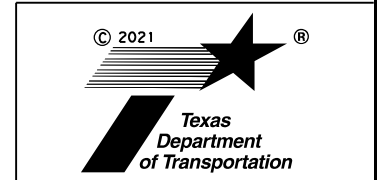

CONT	SECT	JOB	HIGHWAY
0083	03	056	SH 154, ETC
DIST	COUNTY		SHEET NO.
PAR	HOPKINS, ETC		13

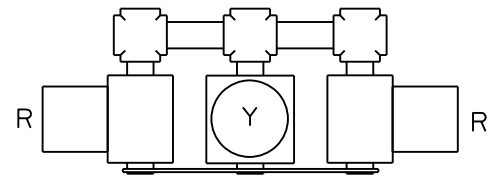

TYPE C

(ONE- TO FOUR-WAY, AS SHOWN ON SIGNAL LAYOUT)

SIGNAL HEAD INDICATIONS

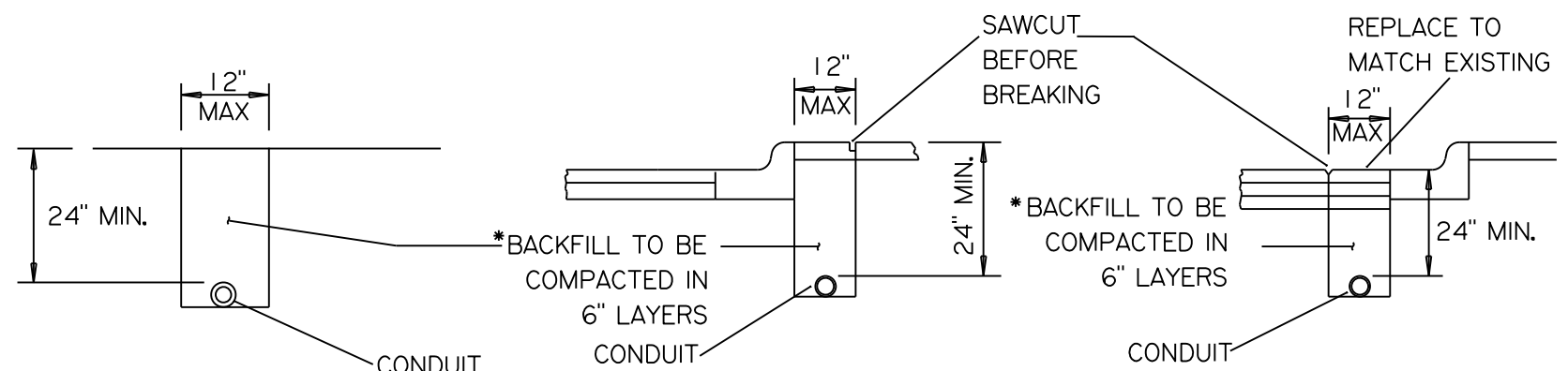

TYPICAL TRENCH DETAILS

*Stabilize all backfill material under pavement with Portland Cement and mix in a concrete mixer or transit mix equipment. Use pit run sand and gravel, and stabilize with two sacks of cement per cubic yard. Mechanically tamp backfill in a moist condition or add water to provide a free flowing mixture.

NOTES:

- 1) SELF TAPPING SCREWS ARE NOT ALLOWED.
- 2) ALL CONDUIT FITTINGS ARE WATERTIGHT.

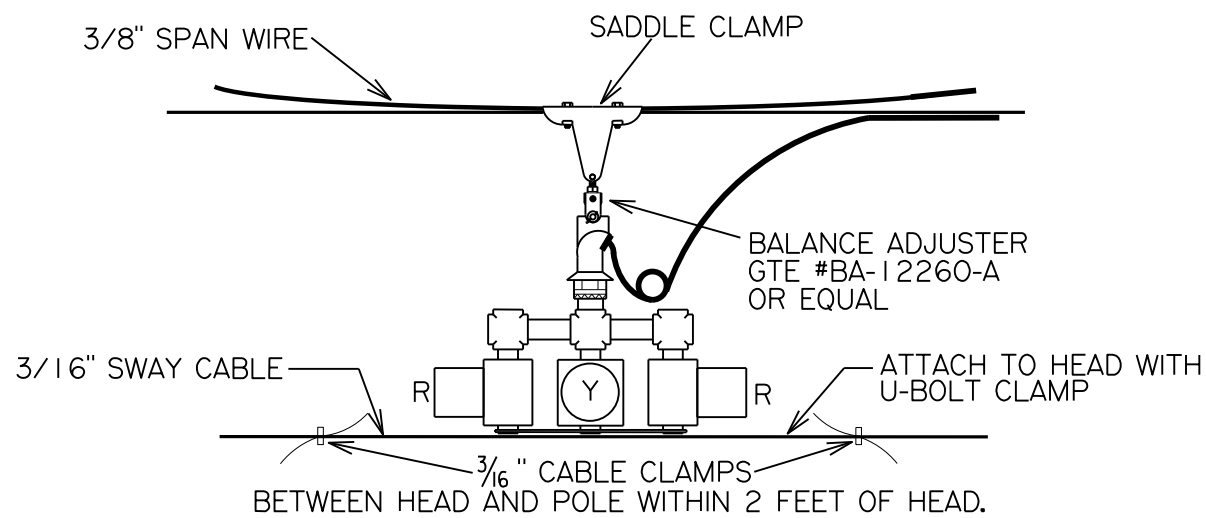

TYPICAL SPAN WIRE MOUNTING

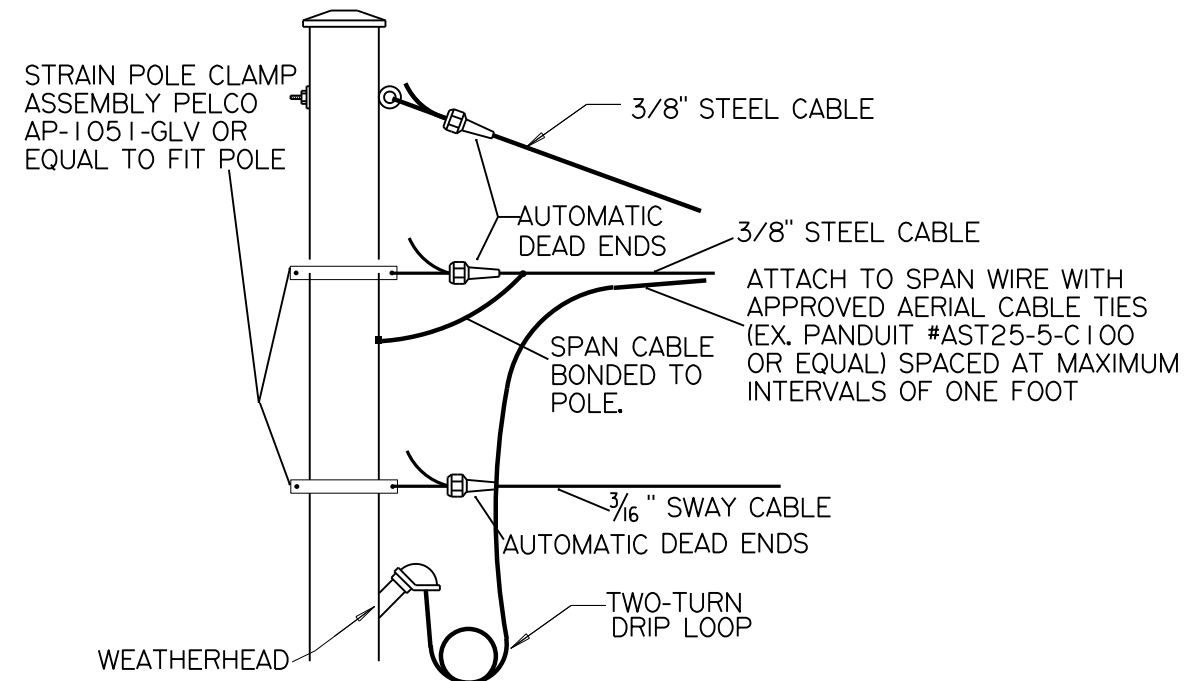

TYPICAL SPAN WIRE ATTACHMENT

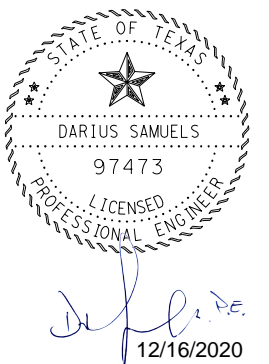

SIGNAL CONSTRUCTION DETAILS

CONT	SECT	JOB	HIGHWAY
0083	03	056	SH 154, ETC
DIST	COUNTY		SHEET NO.
PAR	HOPKINS, ETC		14

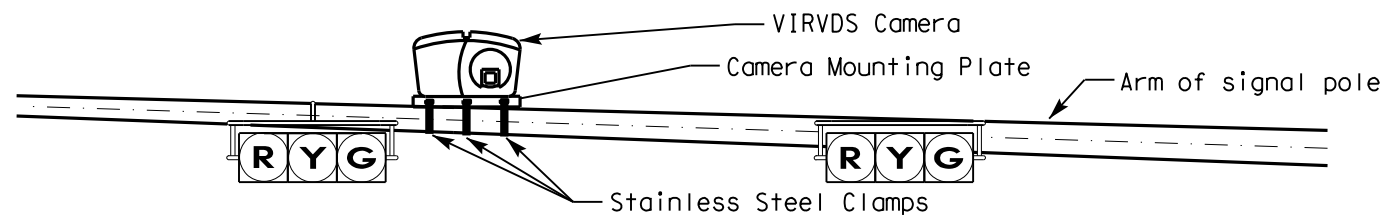

Elevation View

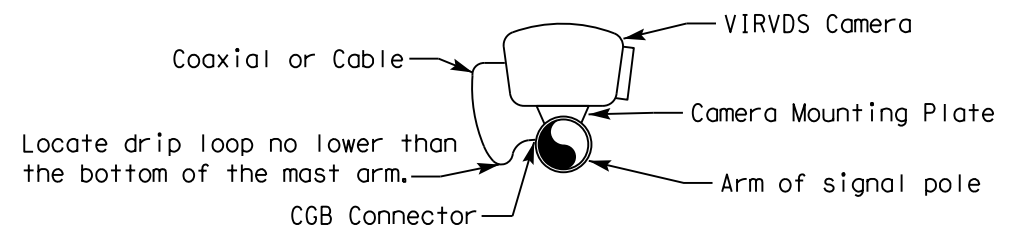

Side View

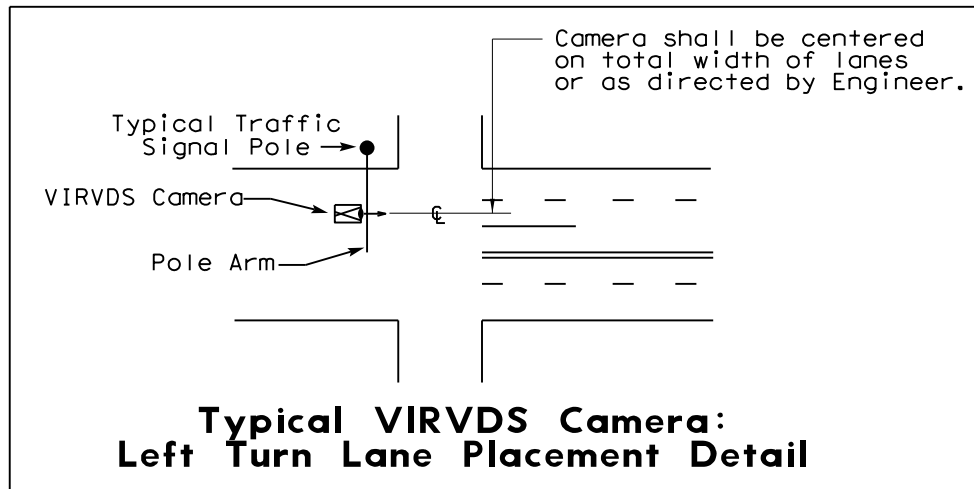
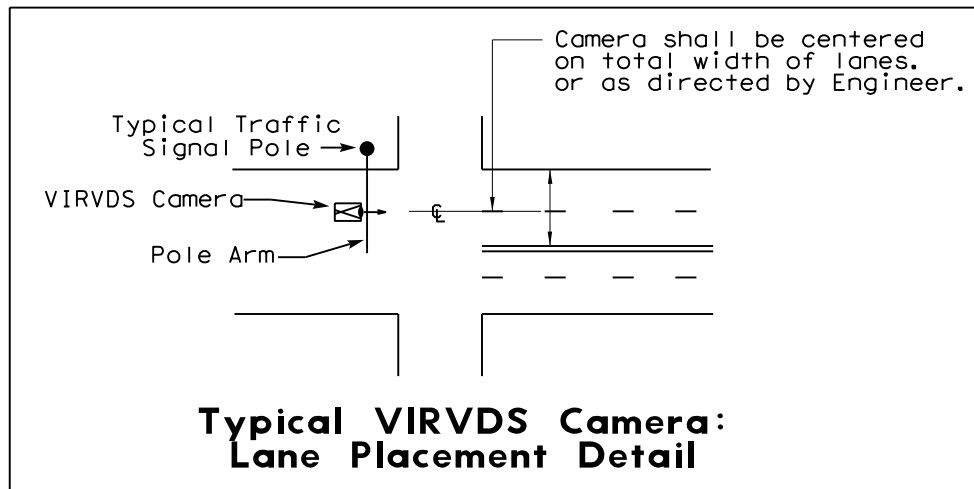

Notes:

1. INSTALL VIDEO DETECTION PROCESSOR UNIT(S) INSIDE THE CONTROLLER CABINET.
2. INSTALL VIDEO DETECTION CAMERA & BRACKET AS DETAILED OR AS APPROVED BY THE ENGINEER.
3. USE STAINLESS STEEL CLAMPS TO INSTALL CAMERA MOUNTS OR METHOD APPROVED BY ENGINEER.
4. AIM THE CAMERA SO THAT THE HORIZON IS NOT VISIBLE IN THE FIELD OF VIEW.
5. INSURE WATER TIGHT CABLE ENTRY AND EXIT POINTS ARE IN THE MAST ARM.

VIDEO IMAGING AND RADAR VEHICLE DETECTION SYSTEM (VIRVDS)

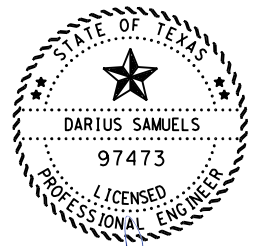

Darius Samuels, P.E.
12/16/2020

TYPICAL VIRVDS CAMERA MOUNTING DETAILS

© 2021 			
CONT	SECT	JOB	HIGHWAY
0083	03	056	SH 154, ETC
DIST	COUNTY	SHEET NO.	
PAR	HOPKINS, ETC	15	

DATE: 12/4/2020
 FILE: U:\TAUSHA\dgnfiles\Our Standards 2012\Maint\eqcomm-ITS.dgn

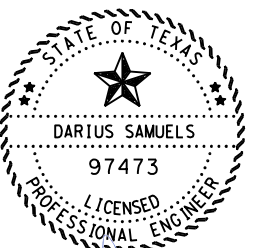
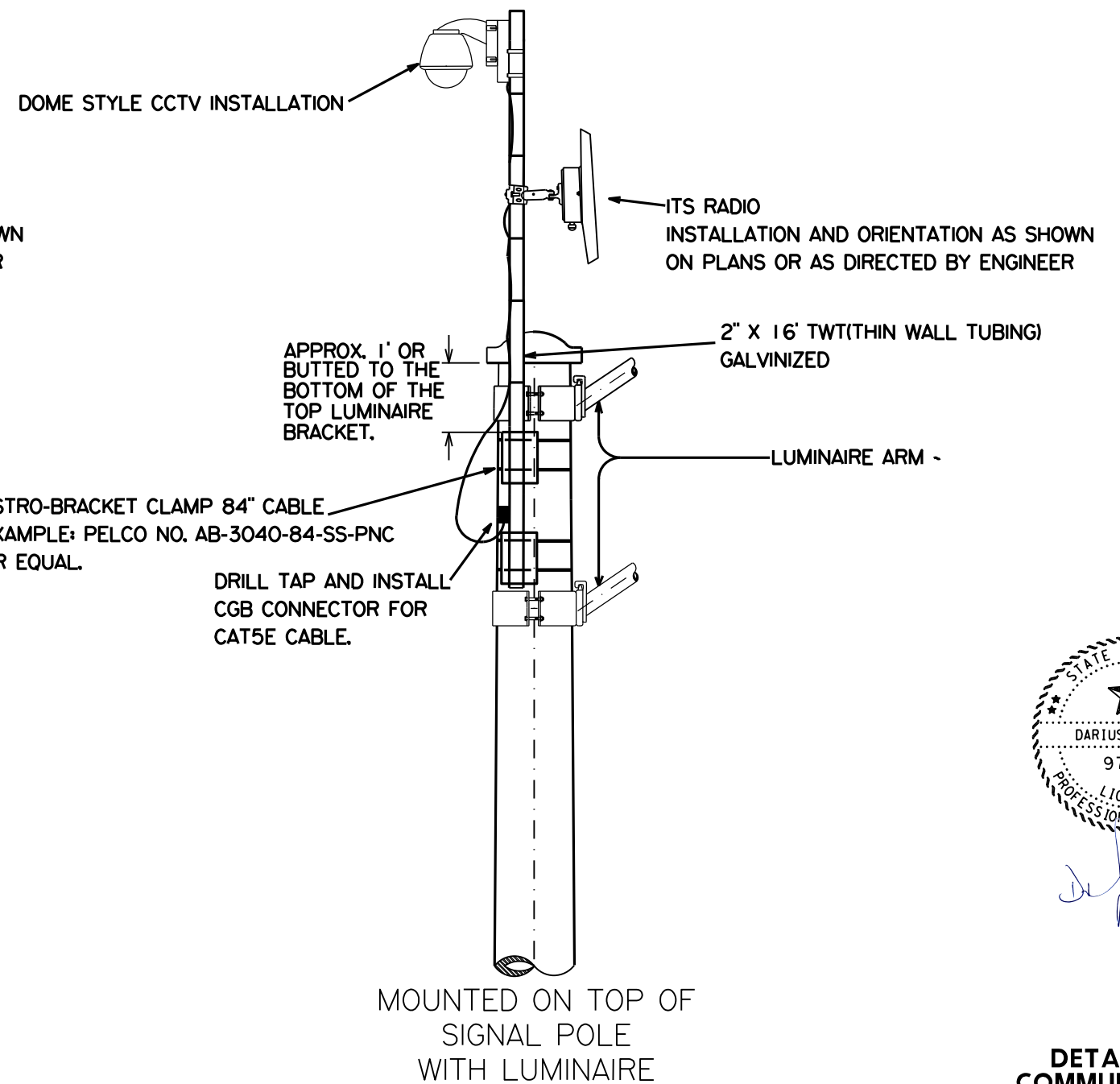
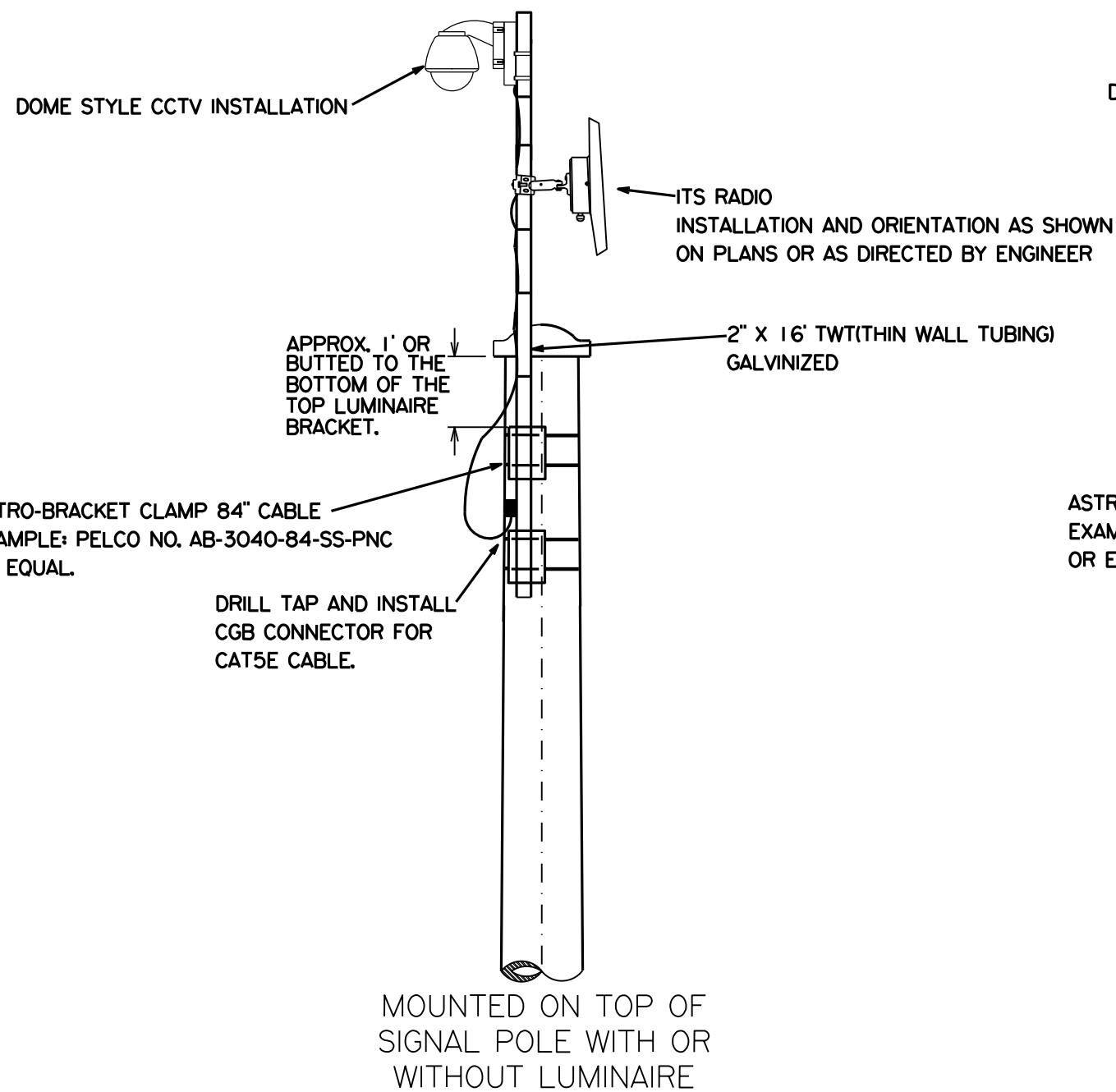

Darius Samuels
 12/16/2020

**DETAIL FOR
 COMMUNICATION
 EQUIPMENT**

© 2021			
CONT	SECT	JOB	HIGHWAY
0083	03	056	SH 154, ETC
DIST	COUNTY		SHEET NO.
PAR	HOPKINS, ETC		16

DISCLAIMER: The use of this standard is governed by the "Texas Engineering Practice Act". No warranty of any kind is made by TxDOT for any purpose whatsoever. TxDOT assumes no responsibility for the conversion of this standard to other formats or for incorrect results or damages resulting from its use.

DATE: 12/4/2020 9:07:01 AM
 FILE: U:\TAUSHA\gnfiles\Our Standards_2012\Maint\sp80.dgn

STRAIN POLE DESCRIPTION	Pole Type	Founda-tion Type	Maximum Permissible Span Wire Load (lbs.)
26' Pole	A	36-A	5200
30' Pole	B	36-A	4600
30' Pole with Lum.	B	36-A	4400
30' Pole with 20' Mast Arm	C	36-B	5600
30' Pole with 24' Mast Arm	C	36-B	5500
30' Pole with 28' Mast Arm	C	36-B	5300
30' Pole with 32' Mast Arm	C	36-B	5100
30' Pole with 36' Mast Arm	C	36-B	4900
30' Pole with 20' Mast Arm & Lum.	C	36-B	5300
30' Pole with 24' Mast Arm & Lum.	C	36-B	5200
30' Pole with 28' Mast Arm & Lum.	C	36-B	5000
30' Pole with 32' Mast Arm & Lum.	C	36-B	4800
30' Pole with 36' Mast Arm & Lum.	C	36-B	4500
34' Pole	D	36-B	5600
34' Pole with Lum.	D	36-B	5400

② Numbers on Load Span Charts indicate the number of signal heads on the span. The total span wire design load is based on one 5-section head and one or more additional 3-section head(s). Design wind pressures on cables are assumed as 1.0 lb/ft. Weight of span wire cables (one per signal head) is assumed as 0.65 lb/ft which includes an allowance for conductor cables and miscellaneous hardware. The effect of the sway cable on load distribution is ignored as it is assumed to break at design wind conditions. When a pole supports 2 spans, the span wire design loads for both spans should be added vectorially to determine the design load for that pole.

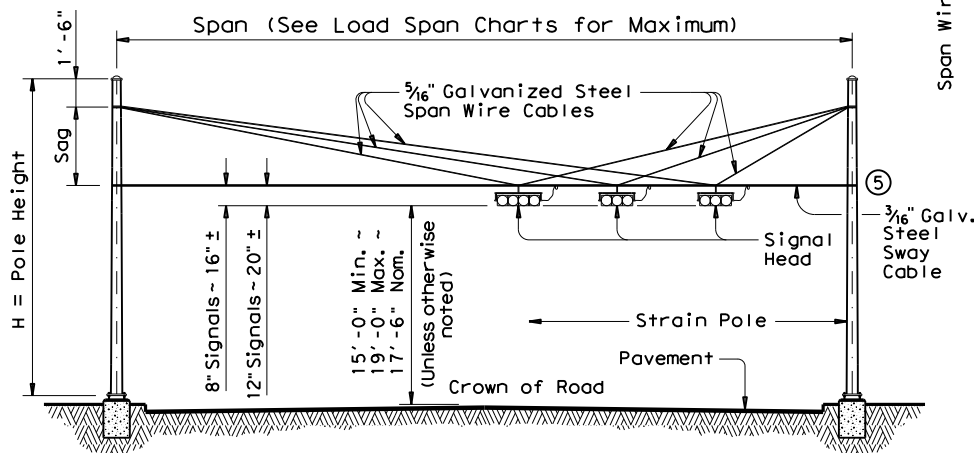

**STRAIN POLE ELEVATIONS
 HORIZONTAL SIGNALS**

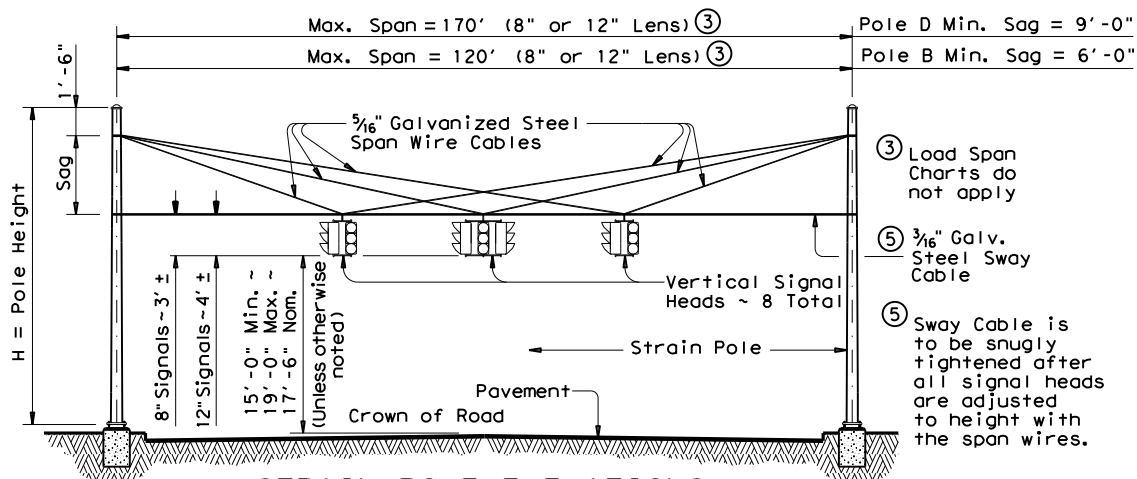

**STRAIN POLE ELEVATIONS
 VERTICAL SIGNALS**
 (Mast arms are not used with vertical signals)

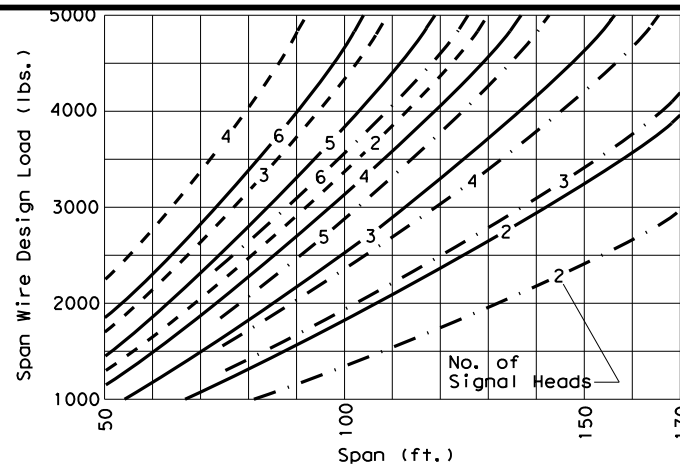

② SIGNALS WITH 12-INCH LENS

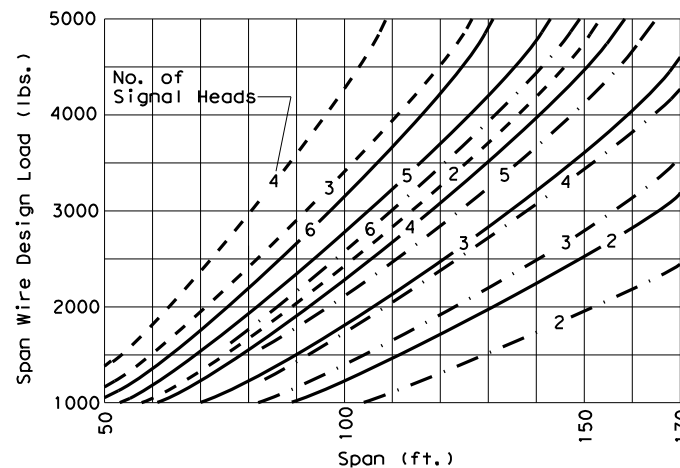

② SIGNALS WITH 8-INCH LENS

Signal Head Type	Wt. Per Head	Wind Area
5-Section, 12" Lens	125 lbs	9.6 sq. ft.
5-Section, 8" Lens	70 lbs	4.8 sq. ft.
3-Section, 12" Lens	75 lbs	5.64 sq. ft.
3-Section, 8" Lens	45 lbs	3.0 sq. ft.

④ Effective projected design wind area (actual area times drag coefficient)

- Sag = 4'-6" (26' or 30' Pole)
- Sag = 8'-0" (30' or 34' Pole)
- - - - - Sag = 11'-6" (34' Pole)

Pole Type	ROUND POLES				POLYGONAL POLES			
	D _B	D _T	(4)thk	H	D _B	D _T	(4)thk	H
A	12.5	8.9	.239	26	13.0	9.0	.239	26
B	13.5	9.3	.239	30	14.0	9.0	.239	30
C	15.5	11.3	.239	30	16.0	11.0	.239	30
D	15.5	10.7	.239	34	16.0	11.0	.239	34

D_B = Pole Base O.D. D_T = Pole Top O.D. H = Pole Height

④ Thickness shown are minimum, thicker materials may be used.

SHIPPING PARTS LIST

Poles (Without Traffic Signal Arm)						
Pole Type	Strain poles with Luminaire			Strain poles without Luminaire		
	Description	Designation	Quantity	Description	Designation	Quantity
A	Ship each pole with the following hardware attached: handhole at base, pole cap, 2 clamp-on simplex and 1 pipe plug.			Ship each pole with the following hardware attached: handhole at base, pole cap and 1 pipe plug.		
B	30' Strain Pole	SPL 30 B-80		30' Strain Pole	SP 30 B-80	
D	34' Strain Pole	SPL 34 D-80	2	34' Strain Pole	SP 34 D-80	

Poles (With Traffic Signal Arm)						
Pole Type	Strain poles with Luminaire			Strain poles without Luminaire		
	Description	Designation	Quantity	Description	Designation	Quantity
C	Ship each pole with the following hardware attached: handhole at base, pole cap, clamp-on simplex and 3 pipe plugs.			Ship each pole with the following hardware attached: handhole at base, pole cap and 3 pipe plugs.		
	30' SPw/TS Arm	SPL 30 C-80		30' SPw/TS Arm	SP 30 C-80	

Traffic Signal Arms (For Type C poles)						
Nominal Arm Length	Type I Arm (1 Signal)		Type II Arm (2 Signals)		Type III Arm (3 Signals)	
	Description	Quantity	Description	Quantity	Description	Quantity
ft.	Ship each Type I Arm with the following hardware attached: 2 CGB Connectors, 1 clamp with bolts and washers		Ship each Type II Arm with the following hardware attached: 1 Bracket Assembly ①, 3 CGB Connectors and 1 clamp with bolts and washers		Ship each Type III Arm with the following hardware attached: 2 Bracket Assemblies ①, 4 CGB Connectors and 1 clamp with bolts and washers	
20	20I-80					
24	24I-80		24 II -80			
28	28I-80		28 II -80			
32			32 II -80		32 III -80	
36			36 II -80		36 III -80	

Anchor Bolt Assemblies (1 per pole)

Anchor Bolt Diameter	Anchor Bolt Length	Quantity
1 3/4"	3'-10"	
2"	4'-3"	2

Luminaire Arms

Nominal Arm Length	Quantity
8' Arm	2

Each Anchor Bolt Assembly consists of the following: Top and Bottom templates, 4 anchor bolts, 8 nuts, 8 flat washers, and 4 nut anchor devices (Type 2) per Standard Drawing "TS-FD".

① See Sheet "DMA-80"

Texas Department of Transportation
 Traffic Operations Division
TRAFFIC SIGNAL SUPPORT STRUCTURES STRAIN POLE ASSEMBLIES
 (80 MPH WIND ZONE)
SP-80(1)-12

© TxDOT March 1996		DN: MS	CK: JSY	DW: BR	CK: JSY
REVISIONS					
0083	03	056	SH 154, ETC		
PAR	HOPKINS, ETC		SHEET NO. 17		

DISCLAIMER: The use of this standard is governed by the "Texas Engineering Practice Act". No warranty of any kind is made by TxDOT for any purpose whatsoever. TxDOT assumes no responsibility for the conversion of this standard to other formats or for incorrect results or damages resulting from its use.

DATE: 12/4/2020 9:07:03 AM
 FILE: U:\TAUSHA\gnfiles\Our Standards_2012\Maint\sp80.dgn

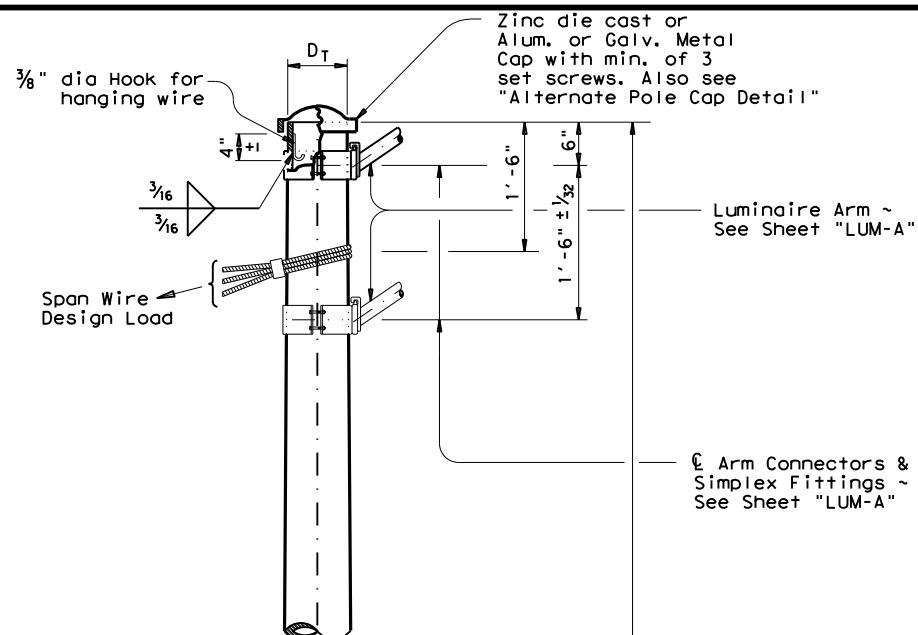

DETAIL A

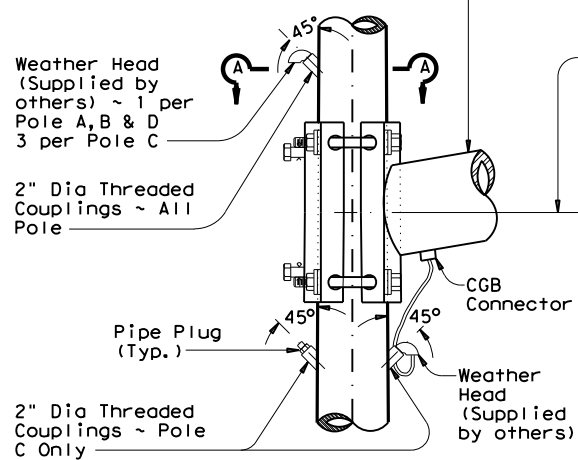

DETAIL B

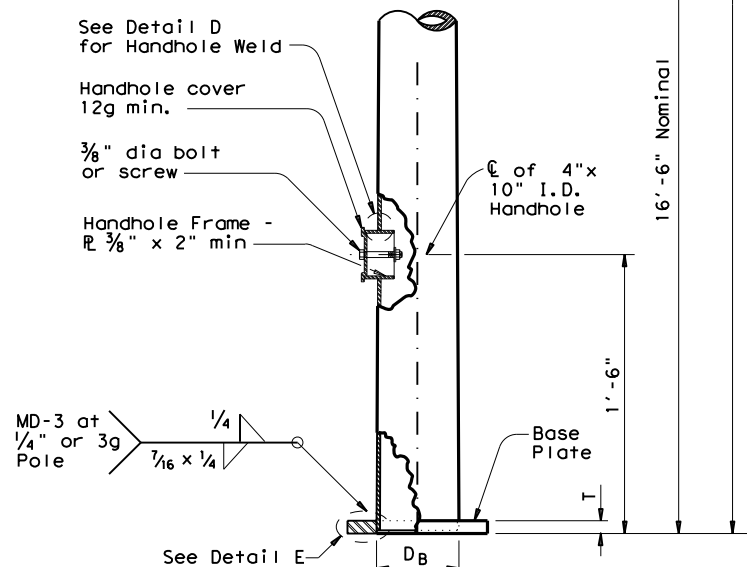

DETAIL C

POLE ELEVATION

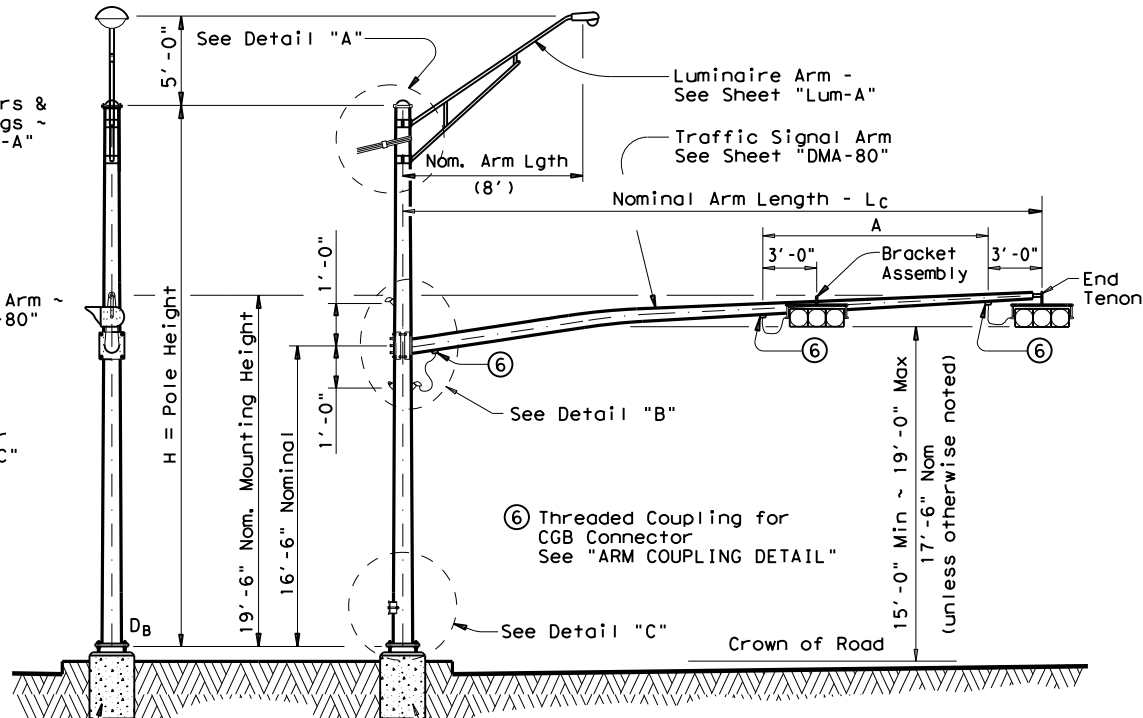
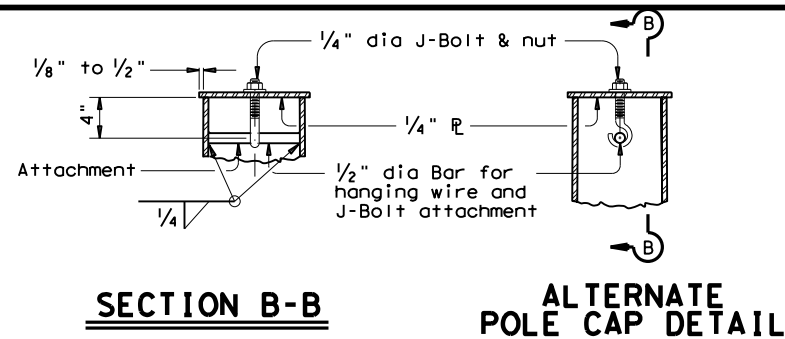

STRUCTURE ASSEMBLY

TABLE OF DIMENSIONS "A"

Arm Length	24'	28'	32'	36'
Arm Type II	10'	11'	12'	13'
Arm Type III			10'	11'

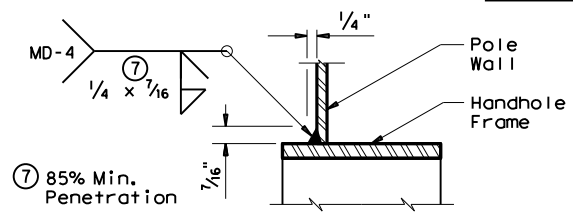

DETAIL D

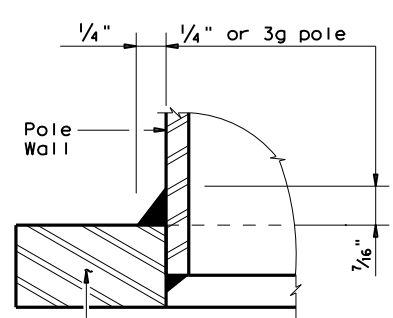

DETAIL E

SECTION A-A
(Pole Coupling and Seam Weld Details)

8 60% Min. penetration, except 100% penetration within 6" of circumferential base welds.

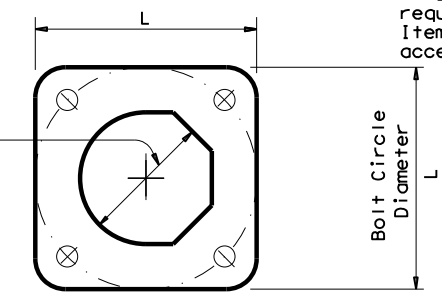

BASE PLATE PLAN

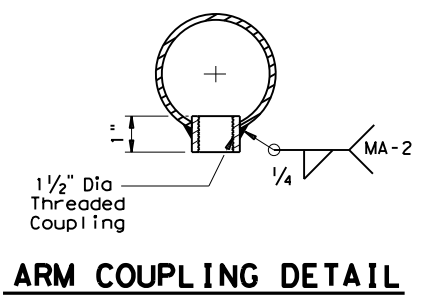

MATERIALS

Round Shafts or Polygonal Shafts 9	ASTM A595 Gr. A, A588, A1008 HSLAS Gr. 50 Class 2, A1011 HSLAS Gr. 50 Class 2, A572 Gr. 50 or A1011 SS Gr. 50 10
Plates 9	ASTM A36, A588, or A572 Gr. 50
Connection Bolts	ASTM A325 except where noted
Pin Bolts	ASTM A325
Pipe 9	ASTM A53 Gr. B, A501, A1008 HSLAS-F Gr. 50, A1011 HSLAS-F Gr. 50
Steel Cable	ASTM A475, 7 Wire Utilities Grade
Misc. Hardware	Galvanized steel or stainless steel or as noted

9 ASTM A572, A1008 HSLAS, A1011 HSLAS, A1008 HSLAS-F, A1011 HSLAS-F, or A1011 SS may have higher yield strengths but shall not have less elongation than the grade indicated.

10 ASTM A1011 SS Gr. 50 shall also have a minimum elongation of 18 percent in 8 inches or 23 percent in 2 inches. Material thickness in excess of those stipulated under A1011 SS will be acceptable providing the material meets all other A1011 SS requirements and the requirements of this item.

GENERAL NOTES

Design conforms to 1994 AASHTO Standard Specifications for Structural Supports for Highway Signs, Luminaires, and Traffic Signals and Interim Specifications thereto. Design Wind Speed equals 80 mph plus a 1.3 gust factor. The maximum permissible span wire design loads tabulated are calculated at a stress load of 1.4 times the basic allowable stress. A simultaneous wind on the pole, mast arm, and luminaire is also included.

See standard sheet "DMA-80" for details of clamp-on traffic signal arms, sheet "MA-C" for traffic signal arm connection details, sheet "LUM-A" for luminaire arm and connection details, and sheet "TS-FD" for anchor bolt and foundation details.

Fabrication shall be in accordance with Item 686, "Traffic Signal Pole Assemblies (Steel)" and with the details, dimensions, and weld procedures shown herein. Weld references call for preapproved weld procedures which the Fabricator must obtain prior to fabrication. Materials, fabrication tolerances, and shipping practices shall meet the requirements of this sheet and Item 686, "Traffic Signal Pole Assemblies (Steel)".

Unless otherwise noted, all parts shall be galvanized in accordance with Item 445, "Galvanizing", after fabrication.

Deviation from the details and dimensions shown herein require submission of shop drawings in accordance with Item 441, "Steel Structures". Alternate designs are not acceptable.

Foundation Type	Anchor Bolt Diameter	Bolt Hole Diameter	Bolt Circle Diameter	Base R. Dim. L x T
36-A	1 3/4"	2"	19"	19" x 1 3/4"
36-B	2"	2 1/4"	21"	21" x 2"

Texas Department of Transportation
 Traffic Operations Division
TRAFFIC SIGNAL SUPPORT STRUCTURES STRAIN POLE ASSEMBLIES
 (80 MPH WIND ZONE)
SP-80(2)-12

© TxDOT March 1996

DN: MS	CK: JSY	DW: BR	CK: JSY
CON: 0083	SECT: 03	JOB: 056	HIGHWAY: SH 154, ETC
DIST: PAR	COUNTY: HOPKINS, ETC	SHEET NO. 18	

DISCLAIMER: The use of this standard is governed by the "Texas Engineering Practice Act". No warranty of any kind is made by TxDOT for any purpose whatsoever. TxDOT assumes no responsibility for the conversion of this standard to other formats or for incorrect results or damages resulting from its use.

DATE: 12/4/2020 9:07:08 AM
 FILE: u:\tausha\dgnfiles\Our Standards_2012\Maint\ts-bp-20.dgn

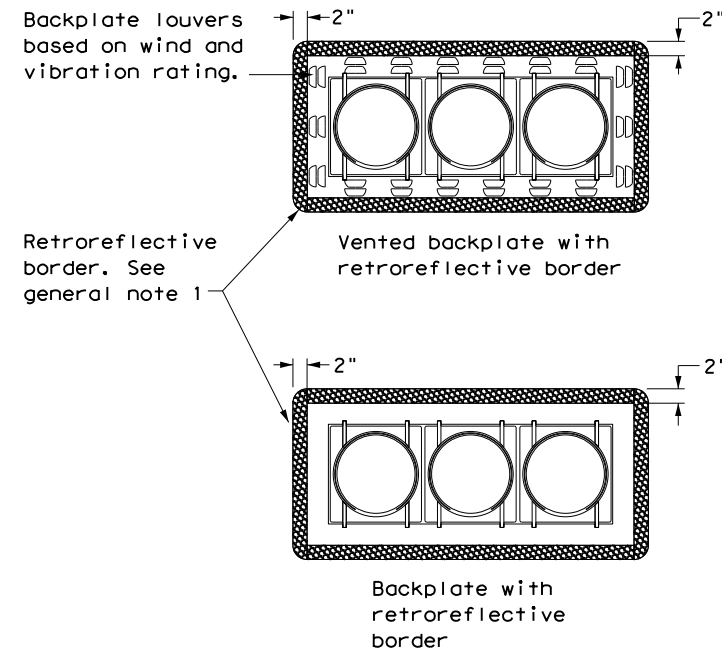

THREE-SECTION HEAD
 HORIZONTAL OR VERTICAL

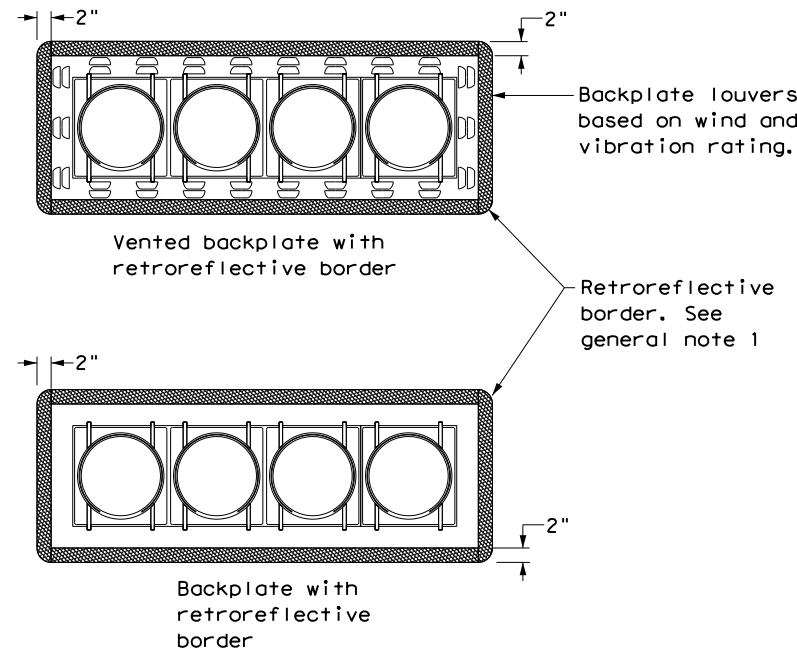

FOUR-SECTION HEAD
 HORIZONTAL OR VERTICAL

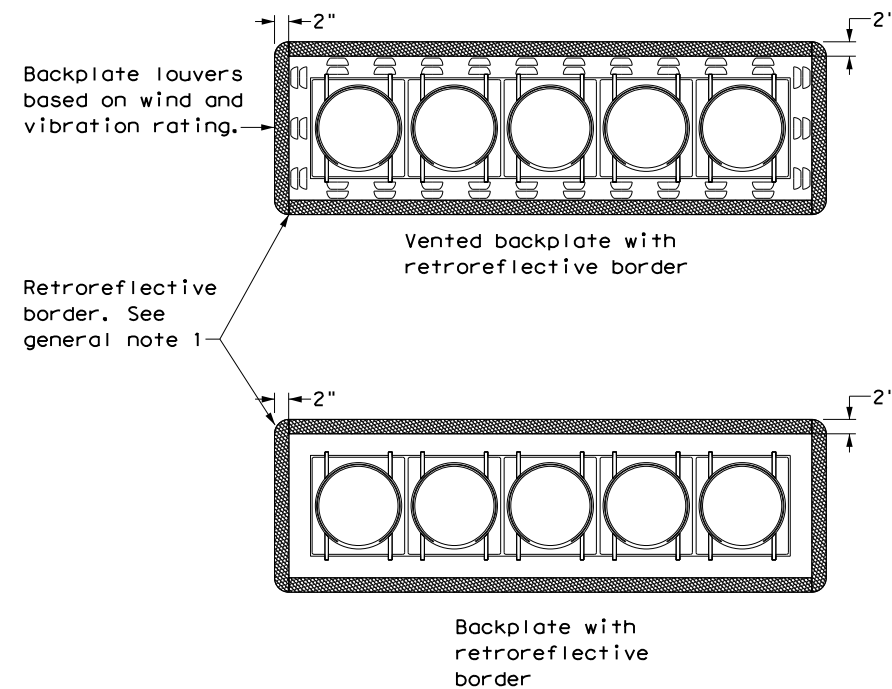

FIVE-SECTION HEAD
 HORIZONTAL OR VERTICAL

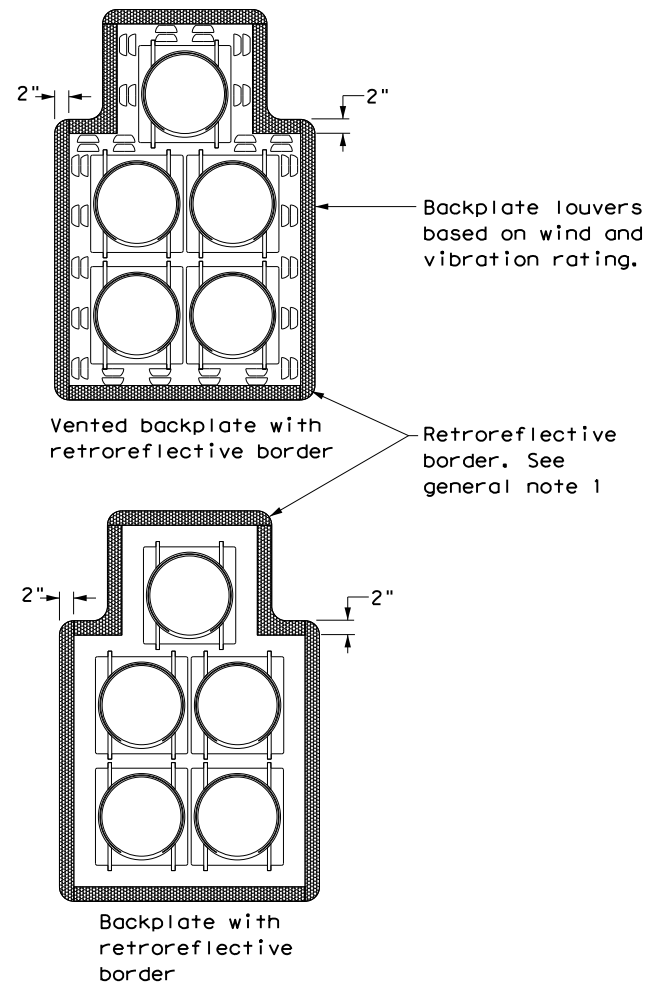

FIVE-SECTION HEAD
 CLUSTER

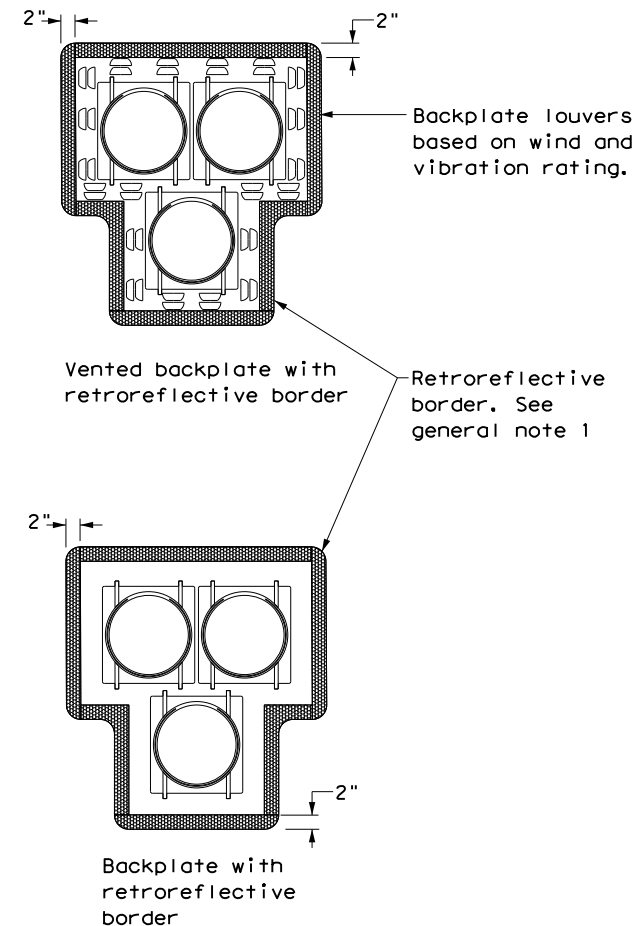

PEDESTRIAN HYBRID
 BEACON

GENERAL NOTES:

1. Backplates are optional for traffic signals and pedestrian hybrid beacons. When backplates are used, a 2-inch wide fluorescent yellow AASHTO Type B_{FL} or C_{FL} retroreflective border conforming to TxDOT DMS-8300 is required. Place on all approaches when used.
2. Signal head and backplate compatibility must be verified by the contractor prior to installation.
3. When using backplates on signal heads, venting is preferred to reduce cyclic vibration stress.
4. When a vented backplate is used, the retroreflective border must not be placed over the louvers.
5. This standard sheet applies to all signal heads with backplates, including but not limited to:
 - Pole mounted
 - Overhead mounted
 - Span wire mounted
 - Mast arm mounted
 - Vertical signal heads
 - Horizontal signal heads
 - Clustered signal heads
 - Pedestrian hybrid beacons

		Texas Department of Transportation		Traffic Safety Division Standard	
TRAFFIC SIGNAL HEAD WITH BACKPLATE					
TS-BP-20					
FILE: ts-bp-20.dgn	DN: TxDOT	CK: TxDOT	DW: TxDOT	CK: TxDOT	
© TxDOT June 2020	CONT	SECT	JOB	HIGHWAY	
REVISIONS	0083	03	056	SH 154, ETC	
DIST	COUNTY		SHEET NO.		
PAR	HOPKINS, ETC		19		

DISCLAIMER: The use of this standard is governed by the "Texas Engineering Practice Act". No warranty of any kind is made by TxDOT for any purpose whatsoever. TxDOT assumes no responsibility for the conversion of this standard to other formats or for incorrect results or damages resulting from its use.

DATE: 12/4/2020 9:07:18 AM
 FILE: T:\PARTRAFAshley\PROJECTS\sh37mtvernonSig\lum-a.dgn

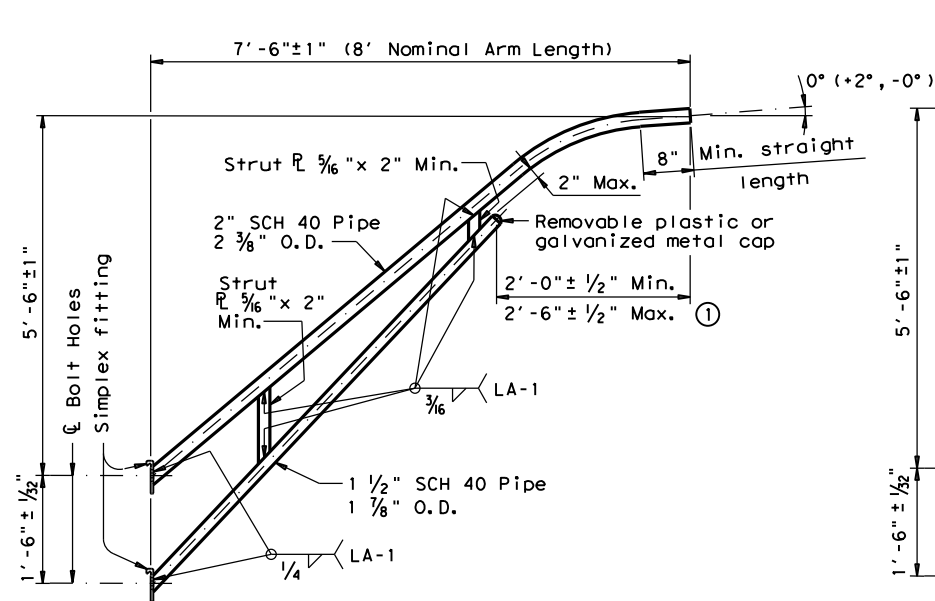

8-FOOT LUMINAIRE ARM

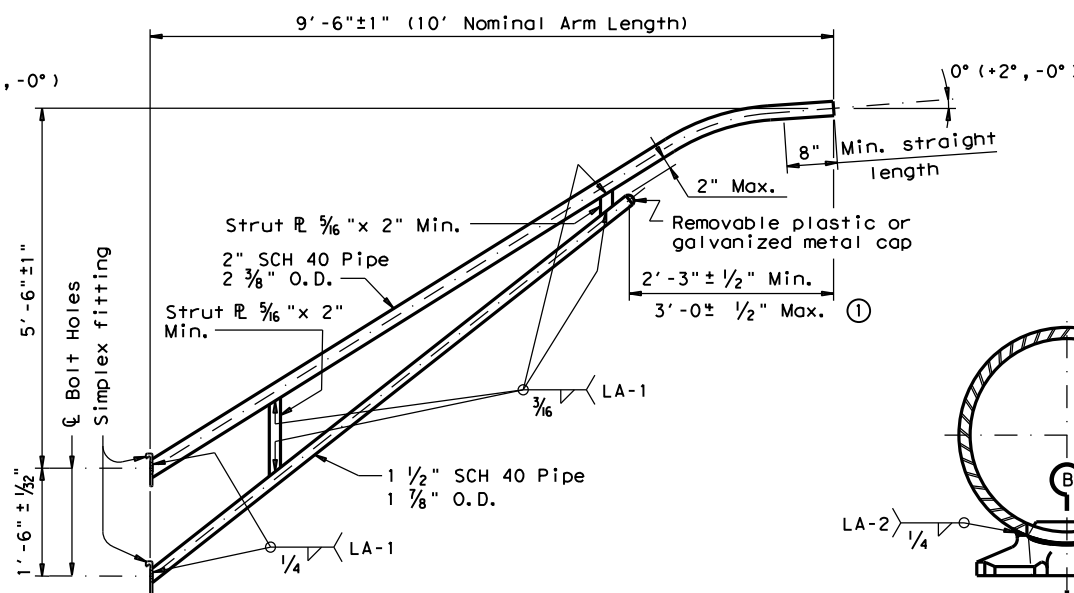

10-FOOT LUMINAIRE ARM

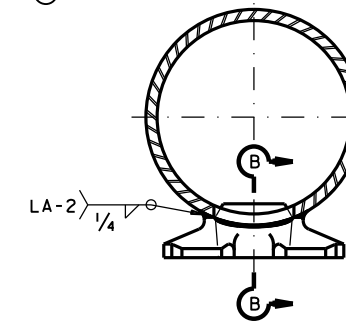

DIRECT ATTACHMENT DETAIL

MATERIALS	
Pole or Arm Simplex	ASTM A27 Gr. 65-35 or A148 Gr. 80-50, A576 Gr. 1021 (3), or A36 (Arm only)
Arm Pipes	ASTM A53 Gr. B, A501, A1008 HSLAS-F Gr. 50 (4), or A1011 HSLAS-F Gr. 50 (4)
Arm Strut Plates (2)	ASTM A36, A572 Gr. 50 (4), or A588
Misc.	ASTM designations as noted

- Dimensional limits are given to show acceptable variation in design. All of a Fabricator's production of a particular arm length shall have the same dimensions within specified tolerances.
- Any of the materials listed for plates may be used where the drawings do not specify a particular ASTM designation.
- A576 must be suitable for forging and also meet minimum tensile strength of 65 ksi, minimum yield of 35 ksi, and elongation in 2 inches of 22 percent.
- ASTM A572, A1008 HSLAS-F, and A1011 HSLAS-F may have higher yield strengths but shall not have less elongation than the grade indicated.

GENERAL NOTES:

Design conforms to 1994 AASHTO Standard Specifications for Structural Supports for Highway Signs, Luminaires, and Traffic Signals and Interim Revisions thereto. Design Wind Speed equals 90 mph plus a 1.3 gust factor. Arms are designed to support a 60 lb. luminaire having an effective projected area (actual area times drag coefficient) of 1.6 sq. ft.

Materials and fabrication shall be in accordance with Item 686, "Traffic Signal Pole Assemblies (Steel)" and with the details, dimensions, and weld procedures shown herein. Weld references call for preapproved weld procedures which the Fabricator must obtain prior to fabrication. In the absence of specified Fabricator tolerances, dimensions shall be within the tolerances generally obtainable in normal fabrication practice.

Unless otherwise noted, all parts shall be galvanized after fabrication in accordance with Item 445, "Galvanizing".

Deviation from the details and dimensions shown herein require submission of shop drawings in accordance with Item 441, "Steel Structures". Alternate designs are not acceptable.

Each pole simplex fitting shall be supplied with 2 ASTM A325 bolts and 2 lock washers of the size specified. The bolts and lock washers shall be secured to the pole with the other hardware items called for in the plans. When clamp attachment is specified, the Fabricator shall ship the clamp assembly securely attached to the pole at the location shown on the plans.

If clamp assemblies are ordered without poles, the Fabricator shall ship one upper and one lower clamp assembly together in a single package, including all nuts and washers required for the clamps and simplex fittings.

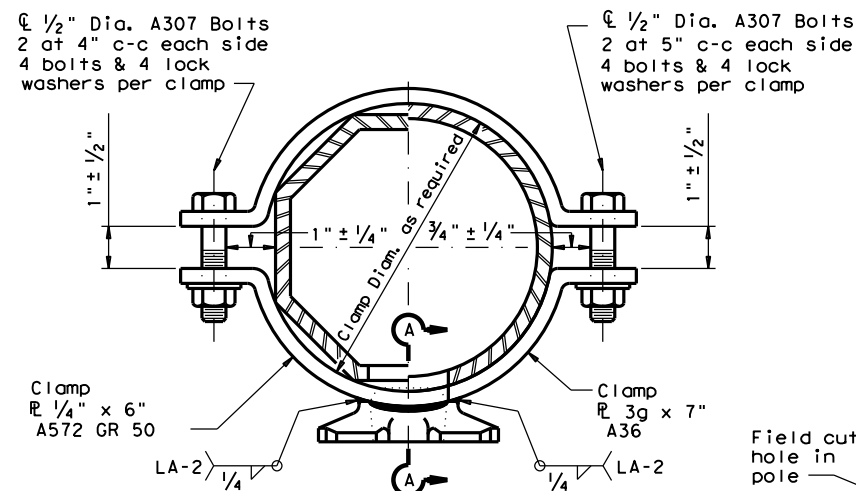

CLAMP ATTACHMENT DETAIL NO. 1 (HALF SECTION)

CLAMP ATTACHMENT DETAIL NO. 2 (HALF SECTION)

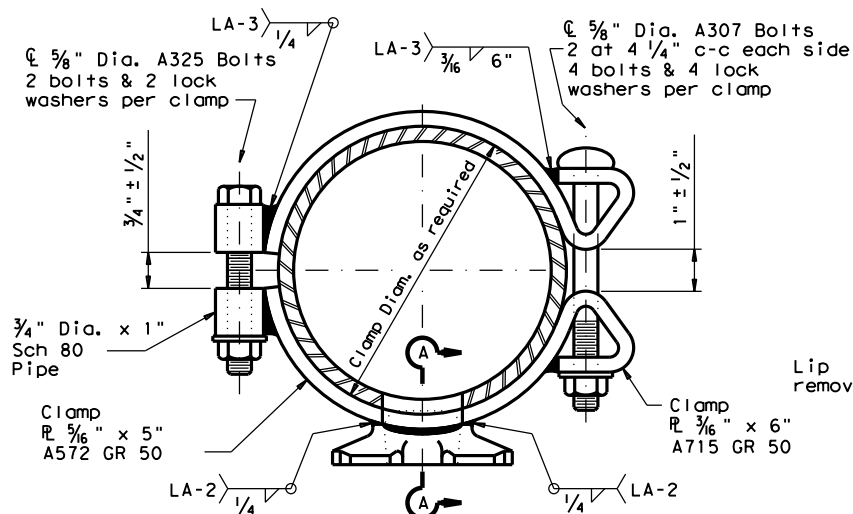

CLAMP ATTACHMENT DETAIL NO. 3 (HALF SECTION)

CLAMP ATTACHMENT DETAIL NO. 4 (HALF SECTION)

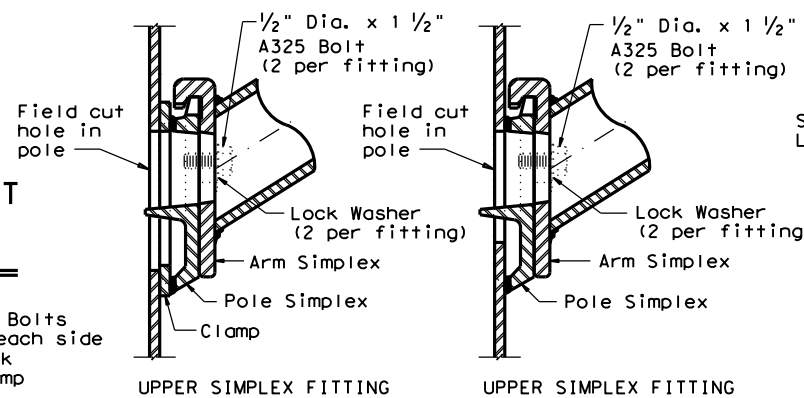

UPPER SIMPLEX FITTING

UPPER SIMPLEX FITTING

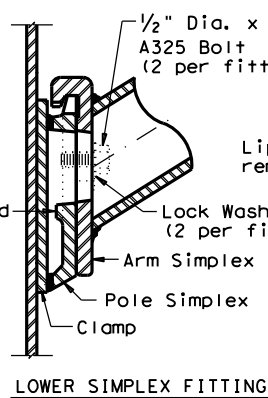

LOWER SIMPLEX FITTING

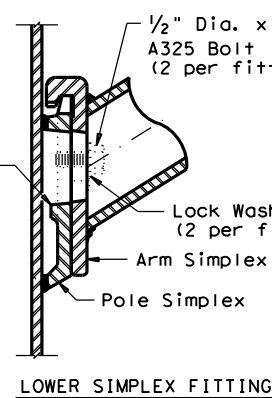

LOWER SIMPLEX FITTING

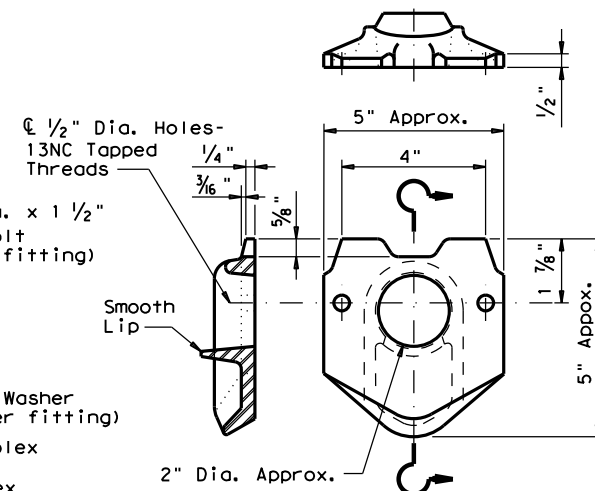

POLE SIMPLEX DETAIL

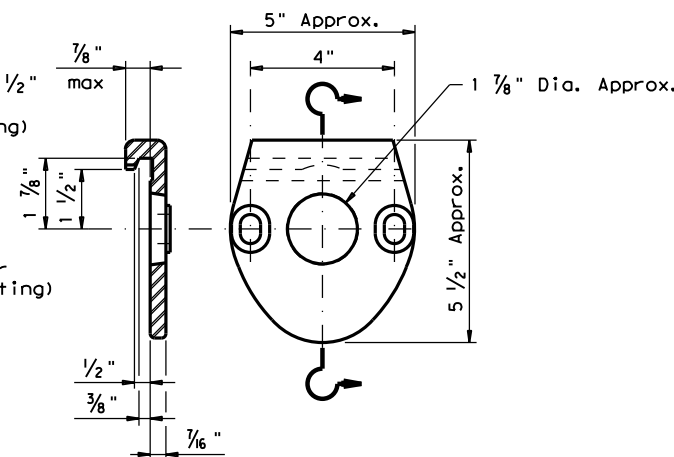

ARM SIMPLEX DETAIL

SECTION A-A

SECTION B-B

Texas Department of Transportation
 Traffic Operations Division
STANDARD ASSEMBLY DRAWINGS FOR LUMINAIRE SUPPORT STRUCTURES
ARM DETAILS
LUM-A-12

© TxDOT August 1995		DN: LEH	CK: JSY	DW: LTT	CK: TEB
5-96	REVISIONS	CONT	SECT	JOB	HIGHWAY
1-99		0083	03	056	SH 154, ETC
1-12		DIST	COUNTY	SHEET NO.	
		PAR	HOPKINS, ETC		21

ROADWAY ILLUMINATION ASSEMBLY NOTES

DISCLAIMER: The use of this standard is governed by the "Texas Engineering Practice Act". No warranty of any kind is made by TxDOT for any purpose whatsoever. TxDOT assumes no responsibility for the conversion of this standard to other formats or for incorrect results or damages resulting from its use.

DATE: 12/4/2020 9:07:23 AM
 FILE: U:\TAUSHA\gnfiles\Our Standards 2012\Maint\rid1-17.dgn

1. Details apply to roadway lighting installations bid or referenced under Item 610, "Roadway Illumination Assemblies." Provide, furnish, and install all other materials not shown on the plans which may be necessary for complete and proper construction. Where manufacturers provide warranties or guarantees as a customary trade practice, furnish to the State such warranties or guarantees.
2. The locations of poles and fixtures may be shifted by the Engineer to accommodate local conditions. Install or remove poles and luminaires located near overhead electrical lines using established industry and utility safety practices and in accordance with laws governing such work. Consult with the appropriate utility company prior to beginning such work.
3. Provide new and unused materials. Ensure that all materials and installations comply with the applicable articles of the National Electrical Code (NEC), TxDOT standards and specifications, National Electrical Manufacturers Association (NEMA), and are listed by Underwriters Laboratories (UL) or a Nationally Recognized Testing Lab (NRTL). NRTLs such as Canadian Standard Association, Intertek Testing Services NA Inc., or FM Approvals LLC can be considered equivalent to UL. Faulty fabrication or poor workmanship in any material, equipment, or installation is justification for rejection.
4. Provide Roadway Illumination Light Fixtures as per TxDOT Departmental Material Specification (DMS) 11010, Item 610, and as shown on the Material Producers List (MPL) for Roadway Illumination and Electrical Supplies.
5. Fabricate steel roadway illumination poles in accordance with Roadway Illumination Poles (RIP) standards and Item 610. Poles fabricated according to RIP standards do not require shop drawing submittals.
 - a. Alternate designs to RIP standards or the use of aluminum to fabricate poles will require the submission of shop drawings electronically. For instructions on submitting shop drawings electronically see "Guide to Electronic Shop Drawing Submittal" on the TxDOT web site.
 - b. Limitations on use of the RIP standard: The RIP standard details were developed for installations in locations where the 3-second gust basic maximum wind speed is 110 mph, and where the elevation of the base of the pole is less than (i.e. not more than) 25' above the elevation of the surrounding terrain, in accordance with the "AASHTO Standard Specifications for Structural Supports for Highway Signs, Luminaires and Traffic Signals," 4th Edition (2001) (AASHTO Design Specifications). For poles to be installed in regions where the maximum basic wind speed exceeds 110 mph or to be mounted more than 25' above the surrounding terrain, provide poles meeting the following requirements:
 - i. Submittals. Following the electronic shop drawing submittal process (see Guide to Electronic Shop Drawing Submittal on the TxDOT web site), submit to the Engineer for approval fabrication drawings and calculations for the poles, sealed by a Texas licensed professional engineer (P.E.).
 - ii. Luminaire Structural Support Requirements. Provide light poles, arms, and anchor bolt assemblies with a 25 year design life to safely resist dead loads, ice loads and the required basic wind speeds at the location of installation in accordance with the 6th edition (2013) of the AASHTO Design Specifications. For transformer base poles, include transformer base and connecting hardware in calculations and shop drawing submittals. Structurally test all transformer bases to resist the theoretical plastic moment capacity of the pole. Submit certification of the plastic moment load test and FHWA breakaway requirement test of the model of base being furnished with the shop drawings. Show breakaway base model number, manufacturer's name, and logo on shop drawings. Include on manufacturer's shop drawings the ASTM designations for all materials to be used.
6. For both transformer and shoe-base type illumination poles, provide and install double-pole breakaway fuse holders as specified by DMS-11040. Breakaway fuse holders are listed on the MPL for Roadway Illumination and Electrical Supplies under Items 610 & 620. Provide 10 amp time delay fuses for breakaway connectors in light poles, or inside the light fixture for underpass luminaires. In each pole, connect luminaires to the breakaway connector with continuous stranded 12 AWG copper conductors as listed on the MPL. Bond all equipment grounding conductors together and to the ground lug in the transformer base or hand hole.
7. Tighten anchor bolts for shoe base, concrete traffic barrier base, and bridge mount roadway illumination poles, in accordance with Item 449.
8. Install T-Base with following procedure:
 - a. Anchor Bolt Tightening.
 - i. Coat the threads of the anchor bolts with electrically conductive lubricant.
 - ii. Place the T-base over the anchor bolts. Foundation must be level and flat. The maximum permissible gap under any one corner of the t-base is 1/8" before nuts are tightened.
 - iii. Coat the bearing surfaces of the nuts and washers with electrically conductive lubricant. Install (1) 1/2" hold down washer, (1) lock washer, and (1) nut on each anchor bolt. Turn the nuts onto the bolts so that each is hand-tight against the washer.
 - iv. Using a torque wrench, tighten each nut to 150 ft-lb. Uniform contact is required between the foundation and the T-base in the corner regions of the T-base, and all corner gaps must be closed after applying torque. If a gap still exists after torquing to 150 ft-lbs, continue torquing each bolt incrementally until gap is closed or maximum allowable torque of 250 ft. pound is reached, whichever comes first. If 250 ft-lbs is not enough to close the gap the foundation must be leveled. Gaps along the straight sides of the T-bases and the foundation are permissible. Ensure that no high point of contact occurs between the straight sides of the T-base and the foundation.
 - v. Check top of T-base for level. If not level then foundation must be leveled.
 - b. Top Bolt Procedure
 - i. Erect pole over T-base with crane. Coat bolts, nuts, washers, and lock washers with electrically conductive lubricant.

- ii. Install bolts and 1/2" connecting washers from the inside of the T-base, thread up through the pole base. Install flat washers, lock washers and nuts snug tight according to Item 447, "Structural Bolting."
 - iii. Tighten each nut to 150 ft-lb. using a torque wrench.
- c. Level and Plumb
- i. Ensure pole is plumb and mast arm is perpendicular to the roadway according to plans to within 5 degrees.
9. Construct luminaire pole foundations in accordance with Item 416, "Drilled Shaft Foundations," and TxDOT standard sheet RID(2).
 10. Provide and install underpass luminaires in accordance with Item 610, DMS-11010, and TxDOT standard sheet RID(3). Typical luminaire size for underpass luminaires is 150W HPS or 150W EQ LED.
 11. Mount luminaires on arms level as shown by the luminaire level indicator.
 12. Orient luminaires perpendicular to the roadway intended to be lit unless otherwise shown on the plans.

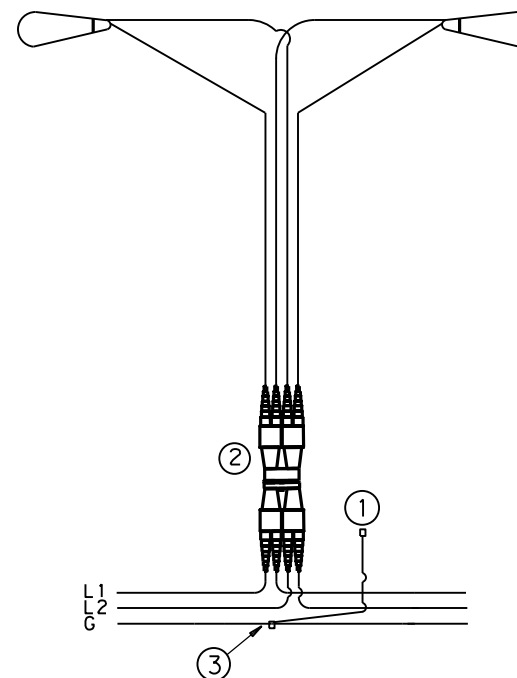

L1, L2 = Hot Conductors
G = Grounding Conductor

TYPICAL WIRING DIAGRAM

LUMINAIRES SERVED AT 480V ON 240/480 VOLT SERVICE OR LUMINAIRES SERVED AT 240V FOR 120/240 VOLT SERVICE.

NOTES:

- ① Use 1/2 in. -13 UNC threaded, copper or tin-plated copper, pole bonding connector, sized appropriately for conductors, bonded to T-base, or use ground lug in handhole as available.
- ② Use pre-qualified two-pole breakaway connectors for all luminaire pole installations. For luminaires fed by a circuit with a neutral conductor, use double pole breakaway connectors with the neutral side unfused and marked white.
- ③ Split Bolt or other connector.

				Traffic Operations Division Standard	
<h1>ROADWAY ILLUMINATION DETAILS</h1> <h2>RID(1)-17</h2>					
FILE:	rid1-17.dgn	DN:	CK:	DW:	CK:
© TxDOT January 2007		CONT	SECT	JOB	HIGHWAY
7-17		0083	03	056	SH 154, ETC
REVISIONS		DIST	COUNTY	SHEET NO.	
		PAR	HOPKINS, ETC	22	

DISCLAIMER: The use of this standard is governed by the "Texas Engineering Practice Act". No warranty of any kind is made by TxDOT for any purpose whatsoever. TxDOT assumes no responsibility for the conversion of this standard to other formats or for incorrect results or damages resulting from its use.

DATE: 12/4/2020 9:07:27 AM
 FILE: u:\tausha\gnfiles\our standards_2012\maint\its(6)-15.dgn

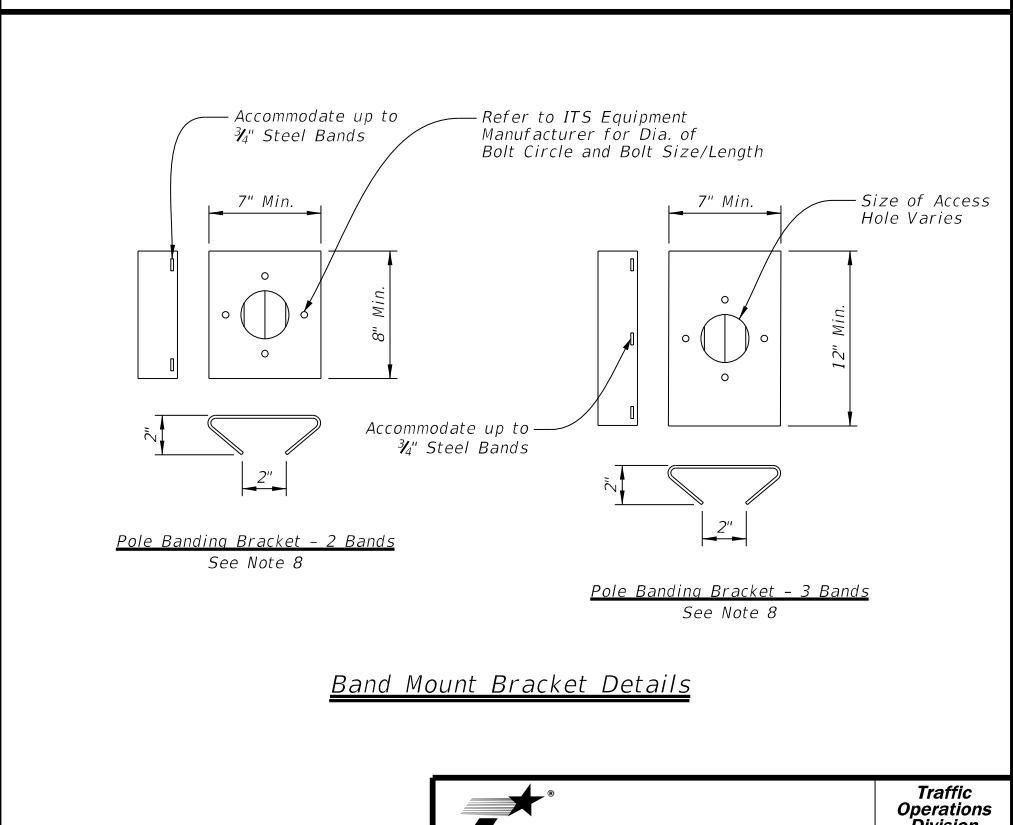
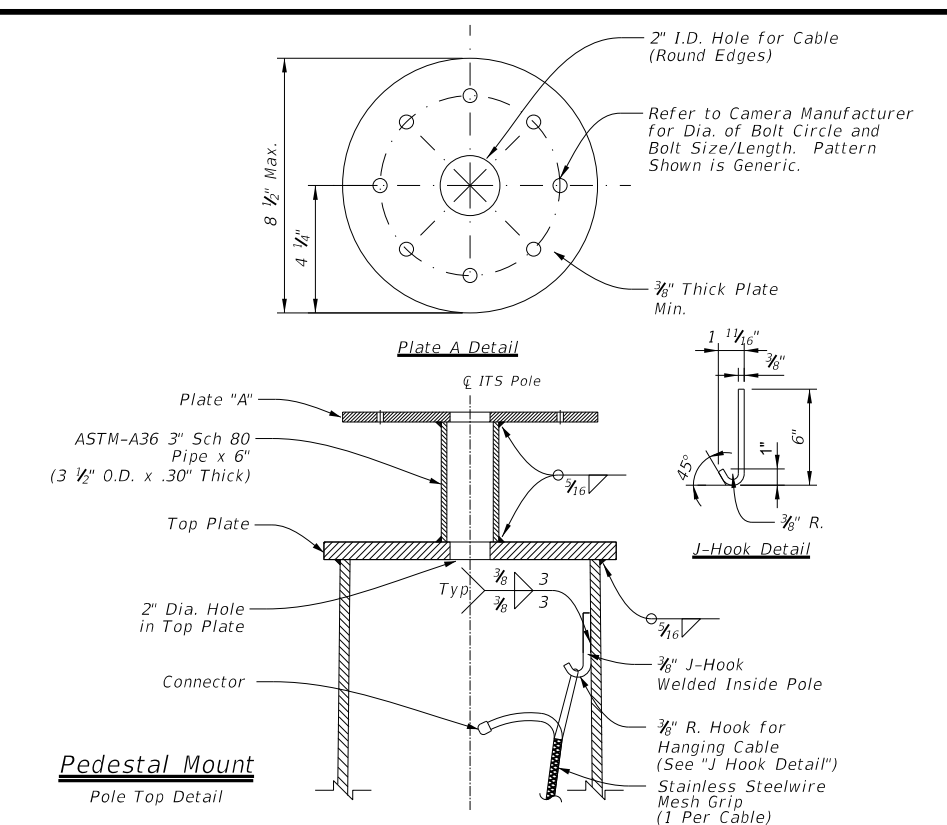
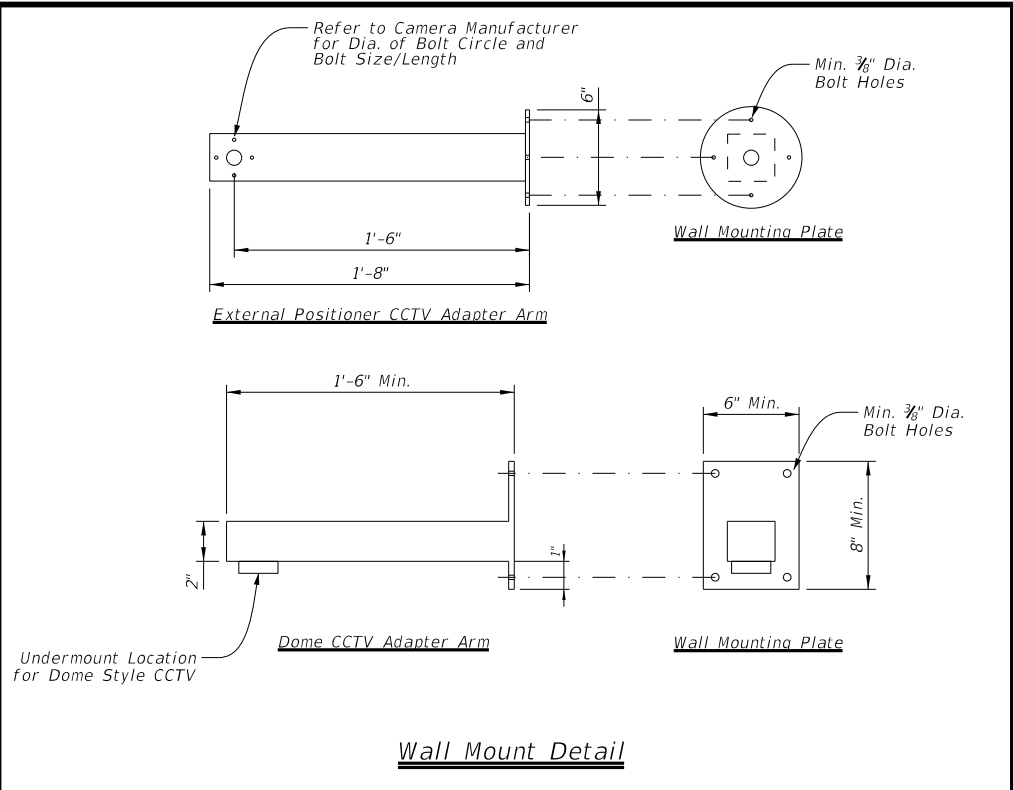
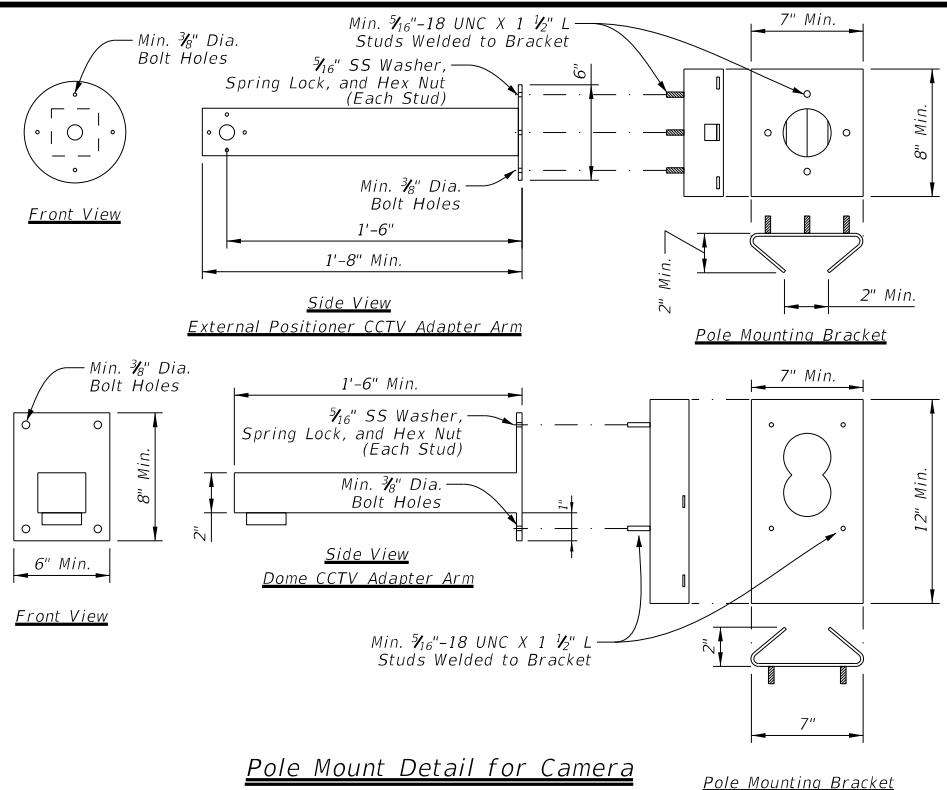
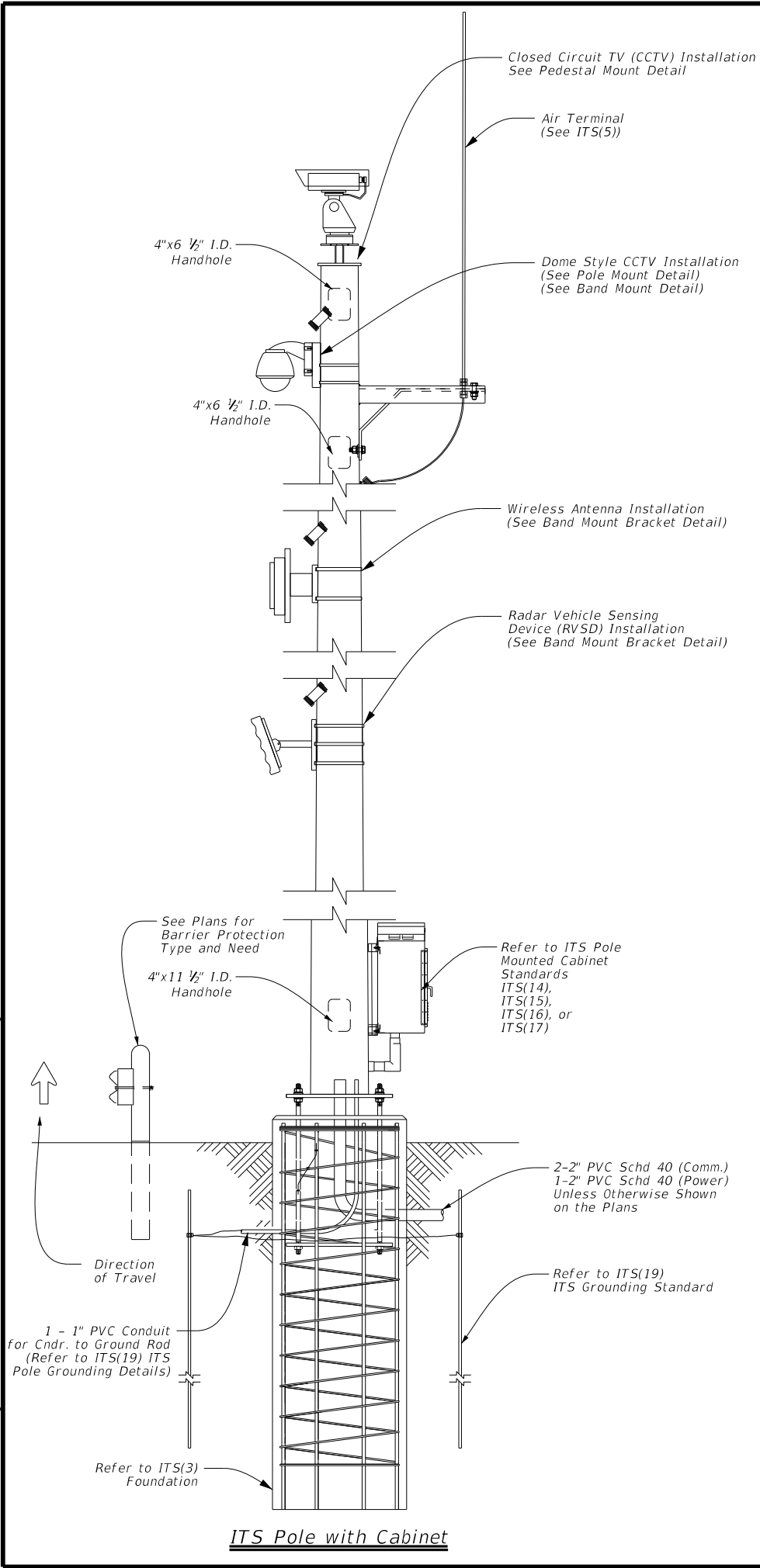

- General Notes:**
- Designed according to Sixth Edition AASHTO Standard Specifications for Structural Supports for Highway Signs, Luminaires, and Traffic Signals and Interim Specifications.
 - Hang all cabling inside ITS pole structure with stainless steel wire mesh grips.
 - Bolt positioning in the pedestal top plate (Plate "A") for the pan/tilt base must be determined in the field per camera manufacturers recommendations. This will allow positioning of the camera to maximize coverage area. The Engineer will determine the camera's blind zone at each location.
 - Provide pedestal top plate and Plate "A" that conform to ASTM A36.
 - Make all welds conform to Item 441 and AWS D1.1 (Structural Welding). Repair damaged galvanized coating per Item 445, "Galvanizing."
 - Galvanize parts in accordance with Item 445, "Galvanizing" unless otherwise noted.
 - The type of ITS equipment shown to be mounted to the ITS pole is intended to represent the most common ITS equipment applications and should not be treated as all inclusive. Other ITS equipment applications may exist that are project specific.
 - Mounting brackets are intended to be diagrammatic and for information only, and are not all inclusive. Contractor responsible for submitting mounting bracket design for approval by the Engineer prior to fabrication. Mounting bracket designed to support a maximum 35 Lbs. Off-the-shelf mounting brackets are acceptable and shall be submitted by shop drawing for approval.
 - Mounting heights to be determined in the field based on manufacturer recommendations.

Texas Department of Transportation
 Traffic Operations Division Standard

ITS POLE EQUIPMENT MOUNTING DETAILS

ITS(6) - 15

FILE: its(6)-15.dgn	DN: TxDOT	CK: TxDOT	DW: TxDOT	CK: TxDOT
© TxDOT June 2015	CONT	SECT	JOB	HIGHWAY
REVISIONS	0083	03	056	SH 154, ETC
	DIST	COUNTY	SHEET NO.	
	PAR	HOPKINS, ETC	23	

GENERAL NOTES FOR ALL ELECTRICAL WORK

1. The location of all conduits, junction boxes, ground boxes, and electrical services is diagrammatic and may be shifted to accommodate field conditions.
2. Provide new and unused materials. Ensure that all materials and installations comply with the applicable articles of the National Electrical Code (NEC), TxDOT standards and specifications, National Electrical Manufacturers Association (NEMA), and are listed by Underwriters Laboratories (UL) or a Nationally Recognized Testing Lab (NRTL). NRTLs such as Canadian Standard Association (CSA), Intertek Testing Services NA Inc., or FM Approvals LLC can be considered equivalent to UL. Where reference is made to NEMA listed devices, International Electrotechnical Commission (IEC) listed devices will not be considered an acceptable equal to a NEMA listed device. Acceptable devices may have both a NEMA and IEC listing. Faulty fabrication or poor workmanship in any material, equipment, or installation is justification for rejection. Replace or reinstall rejected material or equipment at no additional cost to the Department.
3. Miscellaneous nuts, bolts and hardware, except for high strength bolts, may be stainless steel when plans specify galvanized, provided the bolt size is 1/2 in. or less in diameter.
4. Provide the following test equipment as required by the Engineer to confirm compliance with the contract and the NEC: voltmeter, ammeter, megohm meter (1000 volt DC), ground resistance tester, torque wrenches, and torque screwdrivers. Ensure all equipment has been properly calibrated within the last year. Provide calibration certification to the Engineer upon request. Operate test equipment during inspection as requested by the Engineer.
5. Install grounding as shown on the plans and in accordance with the NEC. Ensure all metallic conduits; metal poles; luminaires; and metal enclosures are bonded to the equipment grounding conductor. Provide stranded bare copper or green insulated grounding conductors. Ground rods, connectors, and bonding jumpers are subsidiary to the various bid items.
6. When required by the Engineer, notify the Department in writing of materials from the Material Producers List (MPL) intended for use on each project. Prequalified materials are listed on the MPL on TxDOT's website under "Roadway Illumination and Electrical Supplies." No substitutions will be allowed for materials on this list.

CONDUIT

A. MATERIALS

1. Provide conduit, junction boxes, fittings, and hardware as per TxDOT Departmental Material Specification (DMS) 11030 "Conduit" and Item 618 "Conduit" of TxDOT's "Standard Specifications For Construction And Maintenance Of Highways, Streets, And Bridges," latest edition. Provide conduits listed under Item 618 on the MPL under "Roadway Illumination and Electrical Supplies." Provide conduit types according to the descriptive code or as shown on the plans. Do not substitute other types of conduits for those shown. Provide liquidtight flexible metal conduit (LFMC) when flexible conduit is called for on galvanized steel rigid metallic conduit (RMC) systems. Provide liquidtight flexible nonmetallic conduit (LFNC) when flexible conduit is called for on polyvinyl chloride (PVC) systems.
2. Provide galvanized steel RMC for all exposed conduits, unless otherwise shown on the plans. Properly bond all metal conduits.
3. Unless otherwise shown on the plans, provide junction boxes with a minimum size as shown in the following table, which applies to the greatest number of conductors entering the box through one conduit with no more than four conduits per box. When a mixture of conductor sizes is present, count the conductors as if all are of the larger size. For situations not applicable to the table, size junction boxes in accordance with NEC.

AWG	3 CONDUCTORS	5 CONDUCTORS	7 CONDUCTORS
#1	10" x 10" x 4"	12" x 12" x 4"	16" x 16" x 4"
#2	8" x 8" x 4"	10" x 10" x 4"	12" x 12" x 4"
#4	8" x 8" x 4"	10" x 10" x 4"	10" x 10" x 4"
#6	8" x 8" x 4"	8" x 8" x 4"	10" x 10" x 4"
#8	8" x 8" x 4"	8" x 8" x 4"	8" x 8" x 4"

4. Junction boxes with an internal volume of less than 100 cu. in. and supported by entering raceways must have threaded entries or hubs identified for the intended purpose and supported by connection of two or more rigid metal conduits. Secure conduit within 3 ft. of the enclosure or within 18 in. of the enclosure if all conduit entries are on the same side. Mechanically secure all junction boxes with an internal volume greater than 100 cu. inches.
5. Provide hot dipped galvanized cast iron or sand cast aluminum outlet boxes for junction boxes containing only 10 AWG or 12 AWG conductors. Do not use die cast aluminum boxes. Size outlet boxes according to the NEC.
6. Do not use intermediate metal conduit (IMC) or electrical metallic tubing (EMT) unless specifically required by the plan sheets. When EMT is called for, provide junction boxes made from galvanized steel sheeting, listed and approved for outdoor use, unless otherwise noted on the plans. Size all galvanized steel junction boxes in accordance with the NEC. Provide junction boxes for IMC conduit systems that meet the same requirements for junction boxes used with RMC systems.
7. Provide PVC junction boxes intended for outdoor use on PVC conduit systems, unless otherwise noted on the plans.

8. Provide PVC elbows in PVC conduit systems, unless otherwise shown on the plans. Use only a flat, high tensile strength polyester fiber pull tape for pulling conductors through the PVC conduit system. When galvanized steel RMC elbows are specifically called for in the plans and any portion of the RMC elbow is buried less than 18 in., ground the RMC elbow by means of a grounding bushing on a rigid metal extension. Grounding of the rigid metal elbow is not required if the entire RMC elbow is encased in a minimum of 2 in. of concrete. PVC extensions are allowed on these concrete encased rigid metal elbows. RMC or PVC elbows are subsidiary to various bid items.
9. When required, provide High-Density Polyethylene (HDPE) conduit with factory installed internal conductors according to Item 622 "Duct Cable." At the Contractor's request and with approval by the Engineer, substitute HDPE conduit with no conductors for bored schedule 40 or schedule 80 PVC conduit bid under Item 618. Ensure bored HDPE substituted for PVC is schedule 40 and of the same size PVC called for in the plans. Ensure the substituted HDPE meets the requirements of Item 622, except that the conduit is supplied without factory-installed conductors. Make the transition of the HDPE conduit to PVC (or RMC elbow when required) at the bore pit. Provide conduit of the size and schedule as shown on the plans. Do not extend substituted conduit into ground boxes or foundations. Provide PVC or galvanized steel RMC elbows as called for at all ground boxes and foundations.
10. Use two-hole straps when supporting 2 in. and larger conduits. On electrical service poles, properly sized stainless steel or hot dipped galvanized one-hole standoff straps are allowed on the service riser conduit.

B. CONSTRUCTION METHODS

1. Provide and install expansion joint conduit fittings on all structure-mounted conduits at the structure's expansion joints to allow for movement of the conduit. In addition, provide and install expansion joint fittings on all continuous runs of galvanized steel RMC conduit externally exposed on structures such as bridges at maximum intervals of 150 ft. When requested by the project Engineer, supply manufacturer's specification sheet for expansion joint conduit fittings. Repair or replace expansion joint fittings that do not allow for movement at no additional cost to the Department. Provide the method of determining the amount of expansion to the Engineer upon request. Do not use LFMC or LFNC as a substitute for the required expansion conduit fittings.
2. Space all conduit supports at maximum intervals of 5 ft. Install conduit spacers when attaching metal conduit to surface of concrete structures. See "Conduit Mounting Options" on ED(2). Install conduit support within 3 ft. of all enclosures and conduit terminations.
3. Do not attach conduit supports directly to pre-stressed concrete beams except as shown specifically in the plans or as approved by the Engineer.
4. Unless otherwise shown on the plans, jack or bore conduit placed beneath existing roadways, driveways, sidewalks, or after the base or surfacing operation has begun. Backfill and compact the bore pits below the conduit per Item 476 "Jacking, Boring, or Tunneling Pipe or Box" prior to installing conduit or duct cable to prevent bending of the connections.
5. When placing conduit in the sub-grade of new roadways, backfill all trenches with excavated material unless otherwise noted on the plans. When placing conduit in the sub-base of new roadways, backfill all trenches with cement-stabilized base as per requirements of Items 110 "Excavation", 400 "Excavation and Backfill for Structures", 401 "Flowable Backfill", 402 "Trench Excavation Protection", and 403 "Temporary Special Shoring."
6. Provide and place warning tape approximately 10 in. above all trenched conduit as per Item 618.
7. During construction, temporarily cap or plug open ends of all conduit and raceways immediately after installation to prevent entry of dirt, debris and animals. Temporary caps constructed of durable duct tape are allowed. Tightly fix the tape to the conduit opening. Clean out the conduit and prove it clear in accordance with Item 618 prior to installing any conductors.
8. Ensure conduit entry into the top of any enclosure is waterproof by installing conduit sealing hubs or using boxes with threaded bosses. This includes surface mounted safety switches, meter cans, service enclosures, auxiliary enclosures and junction boxes. Grounding bushings on water tight sealing hubs are not required.
9. Fit the ends of all PVC conduit terminations with bushings or bell end fittings. Provide and install a grounding type bushing on all metal conduit terminations.
10. Install a bonding jumper from each grounding bushing to the nearest ground rod, grounding lug, or equipment grounding conductor. Ensure all bonding jumpers are the same size as the equipment grounding conductor. Bonding of conduit used as a casing under roadways for duct cable is not required, if the duct extends the full length through the casing.
11. At all electrical services, install a 6 AWG solid copper grounding electrode conductor.
12. Place conduits entering ground boxes so that the conduit openings are between 3 in. and 6 in. from the bottom of the box. See the ground box detail on sheet ED(4).
13. Seal ends of all conduits with duct seal, expandable foam, or by other methods approved by the Engineer. Seal conduit immediately after completion of conductor installation and pull tests. Do not use duct tape as a permanent conduit sealant. Do not use silicone caulk as a conduit sealant.
14. File smooth the cut ends of all mounting strut and conduit. Before installing, paint the field cut ends of all mounting strut and RMC (threaded or non-threaded) with zinc rich paint (94% or more zinc content) to alleviate overspray. Use zinc rich paint to touch up galvanized material as allowed under Item 445 "Galvanizing." Do not paint non-galvanized material with a zinc rich paint as an alternative for materials required to be galvanized.

DISCLAIMER: The use of this standard is governed by the "Texas Engineering Practice Act". No warranty of any kind is made by TxDOT for any purpose whatsoever. TxDOT assumes no responsibility for the conversion of this standard to other formats or for incorrect results or damages resulting from its use.

DATE: 12/4/2020 9:07:33 AM
FILE: T:\PARTRAFAshley\PROJECTS\sh37mtvernonSig\ed1-14.dgn

 Texas Department of Transportation		Traffic Operations Division Standard	
<h1>ELECTRICAL DETAILS CONDUITS & NOTES</h1>			
<h2>ED(1) - 14</h2>			
FILE:	ed1-14.dgn	DW:	CK:
© TxDOT	October 2014	CONT	SECT
REVISIONS		0083	03
		056	SH 154, ETC
DIST	COUNTY	SHEET NO.	
PAR	HOPKINS, ETC	24	

ELECTRICAL CONDUCTORS

A. MATERIAL INFORMATION

1. Provide Type XHHW insulated conductors in accordance with Departmental Material Specification (DMS) 11040 "Conductors" and Item 620 "Electrical Conductors." Provide conductors as listed on the Material Producers List (MPL) on the Department web site under "Roadway Illumination and Electrical Supplies" Item 620. Color code insulated conductors in conformance with the NEC. Identify grounded (neutral) conductors with white insulation. Identify grounding conductors (ground wires) with green insulation or bare conductors. Identify ungrounded (hot) conductors with any color insulation except green, white, or gray. Keep color scheme consistent throughout the wiring system. Identify conductors 6 American Wire Gauge (AWG) and smaller by continuous color jacket. Identify electrical conductors 4 AWG and larger by continuous color jacket or by colored tape. When identifying conductors with colored tape, mark at least 6 in. of the conductor's insulation with half laps of tape.
2. Provide a solid copper 6 AWG grounding electrode conductor to bond the electrical service equipment to the concrete encased grounding electrode or the ground rod at the service location. Connect the grounding electrode conductor to the ground rod with a UL listed connector in accordance with DMS 11040. Connect the grounding electrode conductor to the concrete encased grounding electrode as shown in the plans.
3. Where two or more circuits are present in one conduit or enclosure, permanently identify the conductors of each branch circuit by attaching a non-metallic tag around both circuit conductors at each accessible location. Provide tags with two straps, large enough to indicate circuit number, letter, or other identification as shown in the plans. Print circuit identification on the tag with a permanent marker.
4. Use listed compression or screw type pressure connectors, terminal blocks, or split bolt connectors for splicing as specified in DMS 11040. Use hot melt adhesive tape to fill the gap and seal the ends of heat shrink tubing. Provide UL listed gel-filled insulating splice covers. Splicing materials, insulating materials, breakaway disconnects, splice covers, and fuse holders are subsidiary to various bid items.

B. CONSTRUCTION METHODS

1. Use only a flat, high tensile strength polyester fiber pull tape for pulling conductors through the conduit system. After installing conductors in conduit, perform conductor pull test. If a conductor cannot be freely pulled, make any needed alterations or repairs at no additional cost to the department. Perform insulation resistance tests in accordance with Item 620. Coordinate with the Engineer to witness the tests.
2. Leave 2 ft. minimum, 3 ft. maximum length for each conductor up to the splice in ground boxes. Leave 3 ft. minimum, 4 ft. maximum length of conductor in ground boxes when pulled through with no splice. Leave 1 ft. minimum, 1.5 ft. maximum length of conductor at enclosures, weatherheads and pole bases.
3. Make splices only in junction boxes, ground boxes, pole bases, or electrical enclosures and use only listed compression or screw type pressure connectors, terminal blocks, or split bolt connectors. Insulate splices with heavy wall heat shrink tubing or gel-filled insulating splice covers to provide a watertight splice. Overlap conductor insulation with heat shrink tubing a minimum of 2 in. past both sides of the splice. Where heat shrink tubing may not shrink sufficiently to provide a watertight seal around the individual conductors, prior to heating the tubing, increase the diameter of the conductor insulation using hot melt adhesive tape to provide a watertight seal between the individual conductors and the heat shrink tubing. Ensure the tape extends past the heat shrink tubing. Use hot melt adhesive tape to fill the gap and seal the ends of heat shrink tubing. Heat shrink tubing that appears to have been burned, or overheated, is considered defective and must be replaced.
4. Size and install gel-filled insulating splice covers according to manufacturer's specifications when used in place of heat shrink tubing.
5. Wire nuts with factory applied waterproof sealant may be used for 8 AWG or smaller conductors in above ground junction boxes, but not in pole bases or ground boxes. Install wire nuts in an upright position to prevent the accumulation of water.
6. Support conductors in illumination poles with a J-hook at the top of the pole.
7. When terminating conductors, remove the insulation and jacketing material without nicking the individual strands of the conductor. Conductors with nicked individual conductor strands or removed strands will be considered damaged.
8. Replace conductors and cables that are damaged beyond repair or that fail an insulation resistance test at no additional cost to the department.
9. Do not repair damaged conductors with duct tape, electrical tape, or wire nuts. Use only approved splicing methods.
10. Do not terminate more than one conductor under a single connector, unless the connector is rated for multiple conductors. Do not exceed the pressure connector's listing for maximum number and size of conductors allowed.
11. Install breakaway connectors on conductors bid under Item 620 whenever those conductors pass through a breakaway support device. Follow manufacturer's instructions when terminating conductors to breakaway connectors. Properly torque threaded connections. Proper terminations are critical to the safe operation of breakaway devices. Trim waterproofing boots on breakaway connectors to fit snugly around the conductor to ensure waterproof connection. Only one conductor may enter a single opening in a boot. Provide waterproof boots with the correct number of openings. Leave unused openings factory sealed. Use prequalified breakaway connectors as shown on the MPL.

12. Provide and install a separate stranded equipment grounding conductor (EGC) in all conduits that contain circuit wiring of 50 volts or more. Unless shown elsewhere, size the EGC to be the same size as the largest current carrying conductor contained in the conduit. Ensure all EGCs are bonded together at every accessible location. For traffic signal installations, provide a minimum size 8 AWG EGC. The EGC is paid for under Item 620.

C. TEMPORARY WIRING

1. Install temporary conductors and electrical equipment in accordance with the NEC article "Temporary Installations" and Department standard sheets.
2. Provide a ground fault circuit interrupter (GFCI) for power outlets for portable electrical equipment, power tools, ice machines, ice storage bins and refrigerators located outdoors at grade. GFCI may be any one of the following: molded cord and plug set, receptacle, or circuit breaker type.
3. Use listed wire nuts with factory applied sealant for temporary wiring where approved.
4. Enclose conductor splices within a listed enclosure or ground box, or ensure the splices are more than 10 ft. above grade vertically and more than 5 ft. horizontally from any metal structure. Where installing temporary conductors in areas subject to vehicle traffic or mobile construction equipment, ensure the vertical clearance to ground is at least 18 ft. when measured at the lowest point. Ground messenger wires that support power conductors in conformance with the NEC.
5. Protect and when necessary repair any existing electrical conduits uncovered during the construction process in a timely manner and in conformance with the NEC.

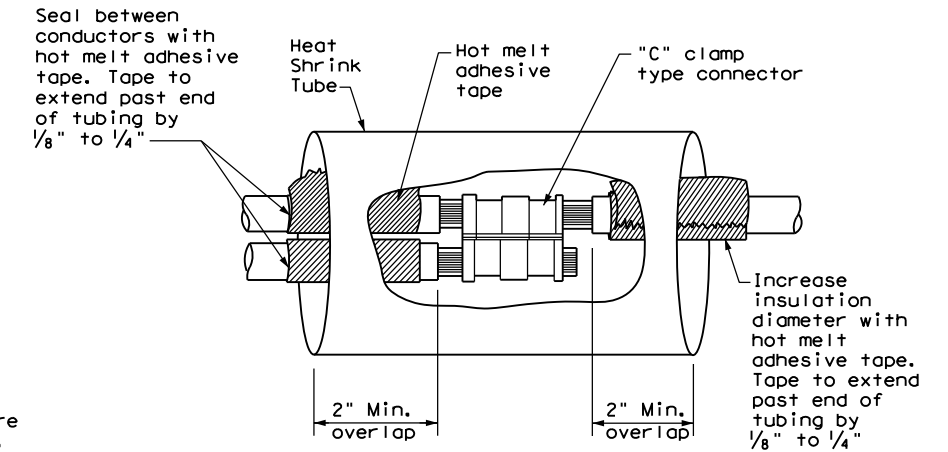

**SPLICE OPTION 1
Compression Type**

GROUND RODS & GROUNDING ELECTRODES

A. MATERIAL INFORMATION

1. Provide and install a grounding electrode at electrical services. Provide ground rods according to DMS 11040 and the plans. Larger diameter or longer length rods may be called for in some specific locations, see the individual plans sheets. Concrete encased grounding electrodes may be called for in specific locations including electrical service, see individual plan sheets.

B. CONSTRUCTION METHODS

1. Furnish auxiliary ground rods for lightning protection and install in soil, concrete, or both, as called for in the plans. For ground rods installed in concrete, ensure the connection of the conductor to the ground rod is readily accessible for inspection or repairs. For ground rods installed in soil, ensure that the upper end is between 2 to 4 in. below finished grade.
2. Do not place ground rods in the same drilled hole as a timber pole.
3. Install ground rods so the imprinted part number is at the upper end of the rod.
4. Remove all non-conductive coatings such as concrete splatter from the rod at the clamp location.
5. Route all conductors as short and straight as possible for connection to lightning protection ground rods. When a bend is required, ensure a minimum radius bend of four inches for these conductors.
6. Unless otherwise called for in the plans, protect grounding electrode conductors with non-metallic conduit. When protecting grounding electrode conductors with metal conduit, provide and install a grounding type bushing and properly sized bonding jumper on each end of the metal conduit.
7. Written authorization is required before installing a ground rod in a horizontal trench for rocky soil or a solid rock bottom.

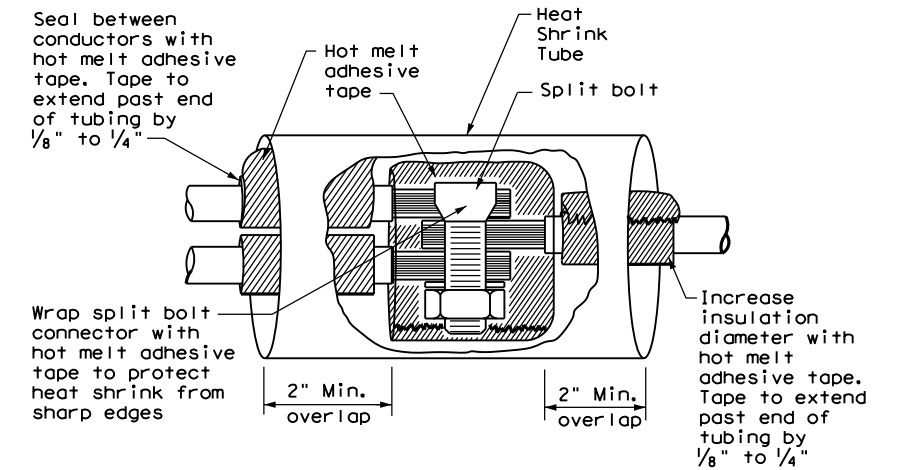

**SPLICE OPTION 2
Split Bolt Type**

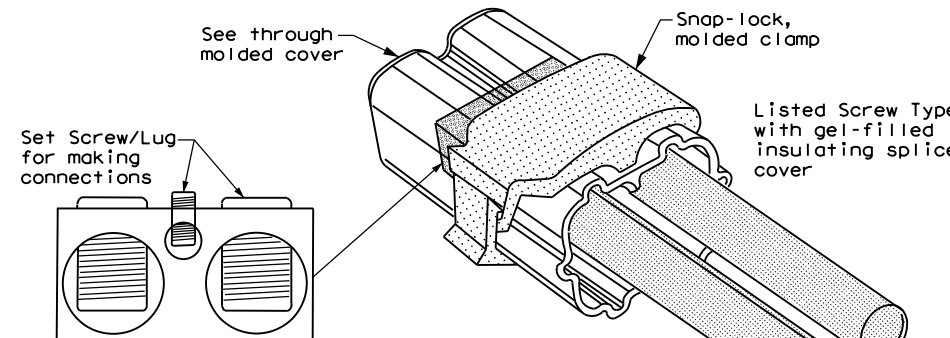

**SPLICE OPTION 3
Listed Screw Type**

		Traffic Operations Division Standard	
<h1>ELECTRICAL DETAILS CONDUCTORS</h1>			
<h2>ED(3) - 14</h2>			
FILE: ed3-14.dgn	DN: TxDOT	CK: TxDOT	DW: TxDOT
© TxDOT October 2014	CONT: 0083	SECT: 03	JOB: SH 154, ETC
REVISIONS	DIST: PAR	COUNTY: HOPKINS, ETC	SHEET NO.: 25

DISCLAIMER: The use of this standard is governed by the "Texas Engineering Practice Act". No warranty of any kind is made by TxDOT for any purpose whatsoever. TxDOT assumes no responsibility for the conversion of this standard to other formats or for incorrect results or damages resulting from its use.
 DATE: 12/4/2020 9:07:38 AM
 FILE: T:\PARTRAF\Ashley\PROJECTS\sh37mtvernonSig\ed3-14.dgn

DISCLAIMER: The use of this standard is governed by the "Texas Engineering Practice Act". No warranty of any kind is made by TxDOT for any purpose whatsoever. TxDOT assumes no responsibility for the conversion of this standard to other formats or for incorrect results or damages resulting from its use.

DATE: 12/4/2020 9:07:43 AM
 FILE: T:\PARTRAF\Ashley\PROJECTS\sh37mtvernonSig\ed4-14.dgn

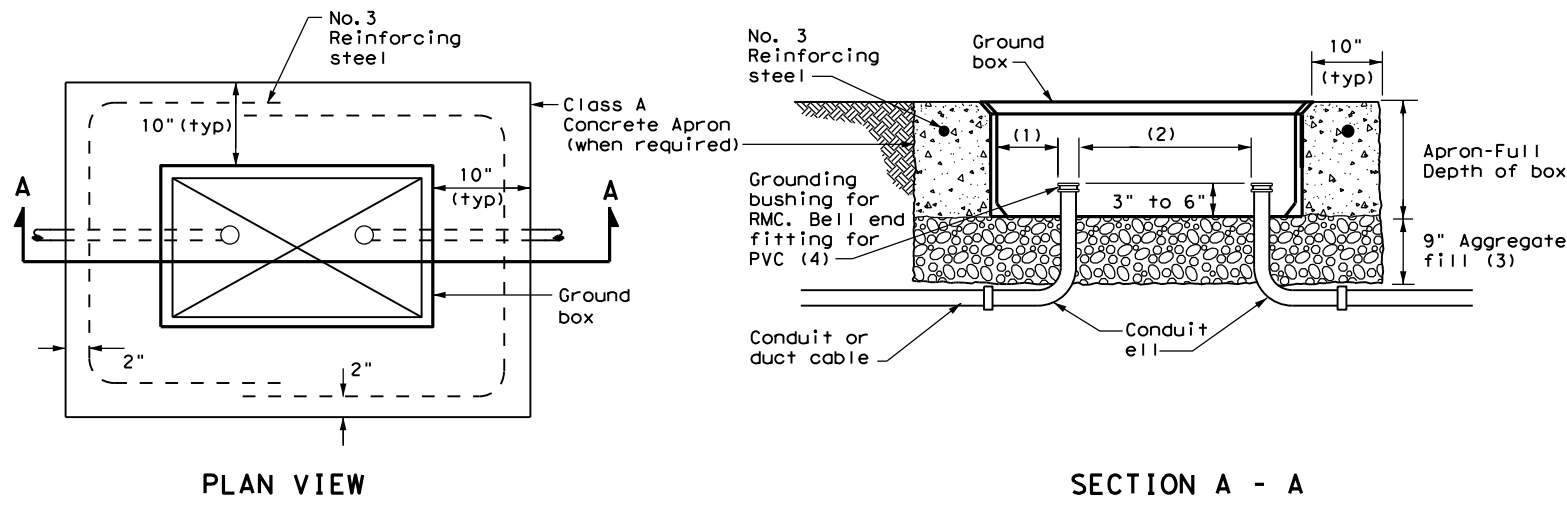

APRON FOR GROUND BOX

- (1) Uniformly space ends of conduits within the ground box. Position ends of conduits so that ground box walls do not interfere with the installation of grounding bushings or bell end fittings.
- (2) Maintain sufficient space between conduits to allow for proper installation of bushing.
- (3) Place aggregate under the box, not in the box. Aggregate should not encroach on the interior volume of the box.
- (4) Install a grounding bushing on the upper end of all RMC terminating in a ground box. Ground RMC elbows when any part of the elbow is less than 18 in. below the bottom of the ground box. Install a PVC bushing or bell end fitting on the upper end of all PVC conduits terminating in a ground box.

GROUND BOX DIMENSIONS	
TYPE	OUTSIDE DIMENSIONS (INCHES) (Width x Length X Depth)
A	12 X 23 X 11
B	12 X 23 X 22
C	16 X 29 X 11
D	16 X 29 X 22
E	12 X 23 X 17

GROUND BOX COVER DIMENSIONS								
TYPE	DIMENSIONS (INCHES)							
	H	I	J	K	L	M	N	P
A, B & E	23 1/4	23	13 3/4	13 1/2	9 7/8	5 1/8	1 3/8	2
C & D	30 1/2	30 1/4	17 1/2	17 1/4	13 1/4	6 3/4	1 3/8	2

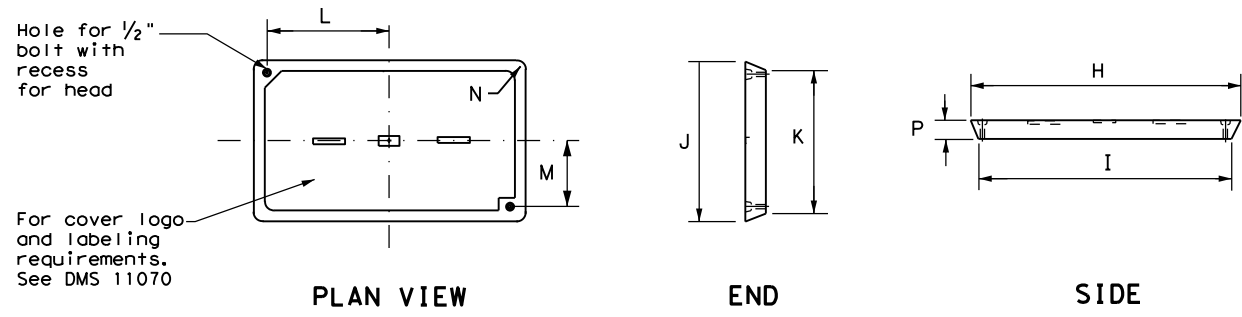

GROUND BOX COVER

GROUND BOXES

A. MATERIALS

1. Provide polymer concrete ground boxes measuring 16x30x24 in. (WxLxD) or smaller in accordance with Departmental Material Specification (DMS) 11070 "Ground Boxes" and Item 624 "Ground Boxes."
2. Provide Type A, B, C, D, and E ground boxes as shown in the plans, and as listed on the Material Producers List (MPL) on the Department web site under "Roadway Illumination and Electrical Supplies," Item 624.
3. Ensure ground box cover is correctly labeled in accordance with DMS 11070.
4. Provide larger ground boxes in accordance with Item 624 and as shown in the plans.

B. CONSTRUCTION METHODS

1. Remove all gravel and dirt from conduit. Cap all conduits prior to placing aggregate and setting ground box. Provide Grade 3 or 4 coarse aggregate as shown on Table 2 of Item 302 "Aggregates for Surface Treatments." Ensure aggregate bed is in place and at least 9 inches deep, prior to setting the ground box. Install ground box on top of aggregate.
2. Cast ground box aprons in place. Reinforcing steel may be field bent. Ensure the depth of concrete for the apron extends from finished grade to the top of the aggregate bed under the box. Ground box aprons, including concrete and reinforcing steel, are subsidiary to ground boxes when called for by descriptive code.
3. Keep bolt holes in the box clear of dirt. Bolt covers down when not working in ground boxes.
4. Install all conduits and ells in a neat and workmanlike manner. Uniformly space conduits so grounding bushings and bell end fittings can easily be installed.
5. Temporarily seal all conduits in the ground box until conductors are installed.
6. Permanently seal conduits immediately after the completion of conductor installation and pull tests. Permanently seal the ends of all conduits with duct seal, expandable foam, or other method as approved. Do not use duct tape as a permanent conduit sealant. Do not use silicone caulk as a sealant.
7. When a ground rod is present in a ground box, bond all equipment grounding conductors together and to the ground rod with listed connectors.
8. When a type B or D ground box is stacked to meet volume requirements, it is allowable to cut an appropriately sized hole for conduit entry in the side wall at least 18 inches below grade.
9. If an existing ground box in the contract has a metal cover, bond the cover to the equipment grounding conductor with a 3 ft. long stranded bonding jumper the same size as the grounding conductor. The bonding jumper is subsidiary to various bid items. Verify existing ground boxes with metal covers are shown on the plans, with notes fully describing the work required.
10. If other ground boxes with metal covers are within the project limits but are not part of the contract, the Engineer may direct the Contractor to bond the metal covers, identifying the specific boxes in writing. This work will be paid for separately.
11. Bond metal ground box covers to the grounding conductor with a tank ground type lug.

				Traffic Operations Division Standard	
<h2>ELECTRICAL DETAILS GROUND BOXES</h2> <h3>ED(4) - 14</h3>					
FILE:	ed4-14.dgn	DN:	TxDOT	CK:	TxDOT
© TxDOT	October 2014	CONT	SECT	JOB	HIGHWAY
REVISIONS		0083	03	056	SH 154, ETC
DIST	COUNTY	SHEET NO.			
PAR	HOPKINS, ETC	26			

ELECTRICAL SERVICES NOTES

- Provide new materials. Ensure installation and materials comply with the applicable provisions of the National Electrical Code (NEC) and National Electrical Manufacturers Association (NEMA) standards. Ensure material is Underwriters Laboratories (UL) listed. Provide and install electrical service conduits, conductors, disconnects, contactors, circuit breaker panels, and branch circuit breakers as shown on the Electrical Service Data chart in the plans. Faulty fabrication or poor workmanship in material, equipment, or installation is justification for rejection. Where manufacturers provide warranties and guarantees as a customary trade practice, furnish these to the State.
- Provide electrical services in accordance with Electrical Details standard sheets, Departmental Material Specification (DMS) 11080 "Electrical Services," DMS 11081 "Electrical Services-Type A," DMS 11082 "Electrical Services-Type C," DMS 11083 "Electrical Services-Type D," DMS 11084 "Electrical Services-Type T," DMS 11085 "Electrical Services-Pedestal (PS)", and Item 628 "Electrical Services" of the Standard Specifications. Provide electrical service types A, C, and D, as listed on the Material Producers List (MPL) on the Department web site under "Roadway Illumination and Electrical Supplies," Item 628. Provide other service types as detailed on the plans.
- Provide all work, materials, services, and any incidentals needed to install a complete electrical service as specified in the plans.
- Coordinate with the Engineer and the utility provider for metering and compliance with utility requirements. Primary line extensions, connection charges, meter charges, and other charges by the utility company to provide power to the location are paid for in accordance with Item 628. Get approval for the costs associated with these charges prior to engaging the utility company to do the work. Consult with the utility provider to determine costs and requirements, and coordinate the work as approved.
- The enclosure manufacturer will provide Master Lock Type 2 with brass tumblers keyed #2195 for all custom electrical enclosures. Installing Contractor is to provide Master Lock #2195 Type 2 with brass tumblers for "off the shelf" enclosures. Master Lock #2195 keys and locks become property of the State. Unless otherwise approved, do not energize electrical service equipment until locks are installed.
- Enclosures with external disconnects that de-energize all equipment inside the enclosure do not need a dead front trim. Protect incoming line terminations from incidental contact as required by the NEC.
- When galvanized is specified for nuts, screws, bolts or miscellaneous hardware, stainless steel may be used.
- Provide wiring and electrical components rated for 75°C. Provide red, black, and white colored XHHW service entrance conductors of minimum size 6 American Wire Gauge (AWG). Identify size 6 AWG conductors by continuous color jacket. Identify electrical conductors sized 4 AWG and larger by continuous color jacket or by colored tape. Mark at least 6 inches of the conductor's insulation with half laps of colored tape, when identifying conductors. Ensure each service entrance conductor exits through a separately bushed non-metallic opening in the weatherhead. The lengths of the conductors outside the weatherhead are to be 12 inches minimum, 18 inches maximum, or as required by utility.
- All electrical service conduit and conductors attached to the electrical service including the riser or the elbow below ground are subsidiary to the electrical service. For an underground utility feed, all service conduit and conductors after the elbow, including service conduit and conductors for the utility pole riser when furnished by the Contractor, will be paid for separately.
- Provide rigid metal conduit (RMC) for all conduits on service, except for the 1/2 in. PVC conduit containing the electrical service grounding electrode conductor. Size the service entrance conduit as shown in the plans. Ensure conduit for branch circuit entry to enclosure is the same size as that shown on the layout sheets for branch circuit conduit. Extend all rigid metal conduits a minimum of 6 inches underground and then couple to the type and schedule of the conduit shown on the layout for that particular branch circuit. Install a grounding bushing on the RMC where it terminates in the service enclosure.
- Use of liquidtight flexible metal conduit (LFMC) is allowed between the meter and service enclosure when they are mounted 90 to 180 degrees to each other. Size the LFMC the same size as service entrance conduit. LFMC must not exceed 3 feet in length. Strap LFMC within 1 foot of each end. LFMC less than 12 inches in length need not be strapped. Each end of LFMC must have a grounding bushing or be terminated with a grounding fitting. The LFMC must contain a grounded (neutral) conductor. Ensure any bend in LFMC never exceeds 180 degrees. A pull test is required on all installed conductors, with at least six inches of free conductor movement demonstrated to the satisfaction of the Engineer.
- Ensure all mounting hardware and installation details of services conform to utility company specifications.
- For all electrical service enclosures listed under Item 628 on the MPL, the UL 508 enclosure manufacturers will prepare and submit a schematic drawing unique to each service. Before shipment to the job site, place the applicable laminated schematic drawings and the laminated plan sheet showing the electrical service data chart used to build the enclosure in the enclosure's data pocket. The installing contractor will copy and laminate the actual project plan sheets detailing all equipment and branch circuits supplied by that service. The laminated plan sheets are to be placed in the service enclosure's document pocket. Reduce 11 in. x 17 in. plan sheets to 8 1/2 in. x 11 in. before laminating. If the installation differs from the plan sheets, the installing contractor is to redline plan sheets before laminating.
- When providing an "Off The Shelf" Type D or Type T service, provide laminated plan sheets detailing equipment and branch circuits supplied by that service. Reduce 11 in. x 17 in. plan sheets to 8 1/2 in. x 11 in. before laminating. Deliver these drawings before completion of the work to the Engineer, instead of placing in enclosure that has no door pocket.
- Do not install conduit in the back wall of a service enclosure where it would penetrate the equipment mounting panel inside the enclosure. Provide grounding bushings on all metal conduits, and terminate bonding jumpers to grounding bus. Grounding bushings are not required when the end of the metal conduit is fitted with a conduit sealing hub or threaded boss, such as a meter base hub.

SERVICE ASSEMBLY ENCLOSURE

- Provide threaded hub for all conduit entries into the top of enclosure.
- Type galvanized steel (GS) enclosures may be used for Type C panelboards and for Type D and T services that do not use an enclosure mounted photocell or lighting contactor. Provide GS enclosures in accordance with DMS 11080, 11082, 11083, and 11084.
- Provide aluminum (AL) and stainless steel (SS) enclosures for Types A, C, and D in accordance with DMS 11080, 11081, 11082, 11083, and 11084. Do not paint stainless steel.
- Provide pedestal service (PS) enclosures in accordance with ED(9) and DMS 11080 and 11085. Do not provide GS pedestal services. If GS is shown in the PS descriptive code, provide an AL enclosure.

MAIN DISCONNECT & BRANCH CIRCUIT BREAKERS

- Field drill flange-mounted remote operator handle if needed, to ensure handle is lockable in both the "On" and "Off" positions.
- When the utility company provides a transformer larger than 50 KVA, verify that the available fault current is less than the circuit breaker's ampere interrupting capacity (AIC) rating and provide documentation from the electric utility provider to the Engineer.

PHOTOELECTRIC CONTROL

- Provide photocell as listed on the MPL. Move, adjust, or shield the photocell from stray or ambient night time light to ensure proper operation. Mount photocell facing north when practical. Mount top of pole photocells as shown on Top Mounted Photocell Detail.

* ELECTRICAL SERVICE DATA												
Elec. Service ID	Plan Sheet Number	Electrical Service Description	Service Conduit *xSize	Service Conductors No./Size	Safety Switch Amps	Main Ckt. Bkr. Pole/Amps	Two-Pole Contractor Amps	Panelbd/ Loadcenter Amp Rating	Branch Circuit ID	Branch Ckt. Bkr. Pole/Amps	Branch Circuit Amps	KVA Load
SB 183	289	ELC SRV TY A 240/480 100(SS)AL(E)SF(U)	2"	3/#2	100	2P/100	100	N/A	Lighting NB	2P/40	26	28.1
									Lighting SB	2P/40	25	
									Underpass	1P/20	15	
NB Access	30	ELC SRV TY D 120/240 060(NS)SS(E)TS(O)	1 1/4"	3/#6	N/A	2P/60		100	Sig. Controller	1P/30	23	5.3
							30		Luminaires	2P/20	9	
									CCTV	1P/20	3	
2nd & Main	58	ELC SRV TY T 120/240 000(NS)GS(N)SP(O)	1 1/4"	3/#6	N/A	N/A	N/A	70	Flashing Beacon 1	1P/20	4	1.0
									Flashing Beacon 2	1P/20	4	

* Example only, not for construction. All new electrical services must have electrical service data chart specific to that service as shown in the plans.
 ** Verify service conduit size with utility. Size may change due to utility meter requirements. Ensure conduit size meets the National Electrical Code.

EXPLANATION OF ELECTRICAL SERVICE DESCRIPTIVE CODE

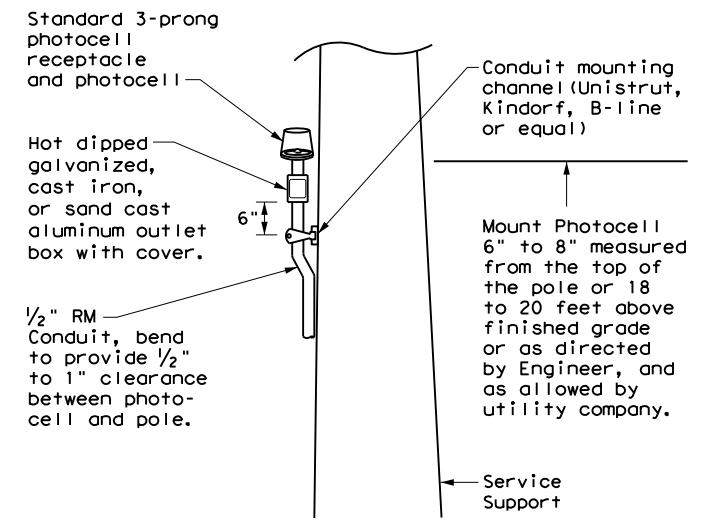
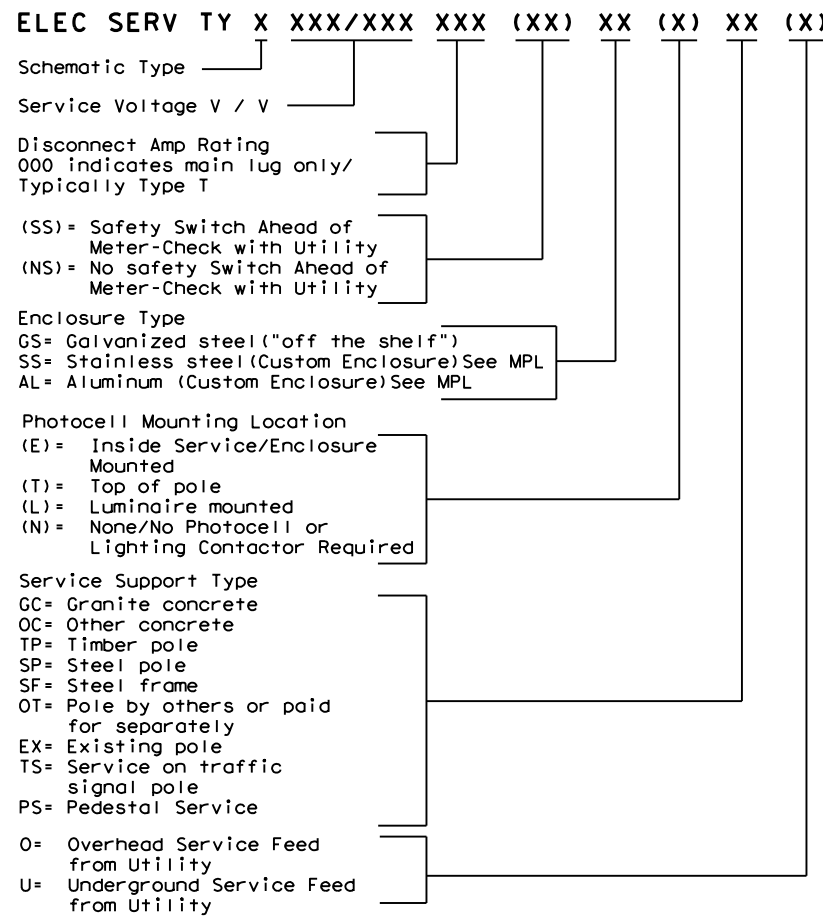

TOP MOUNTED PHOTOCELL

Install conduit strap maximum 3 feet from box. 5 foot maximum spacing between straps supporting conduit.

Texas Department of Transportation
 Traffic Operations Division Standard

ELECTRICAL DETAILS SERVICE NOTES & DATA

ED(5) - 14

FILE: ed5-14.dgn	DWG: TxDOT	CHK: TxDOT	DWG: TxDOT	CHK: TxDOT
© TxDOT October 2014	CONT	SECT	JOB	HIGHWAY
REVISIONS	0083	03	056	SH 154, ETC
DIST	COUNTY		SHEET NO.	
PAR	HOPKINS, ETC		27	

DISCLAIMER: The use of this standard is governed by the "Texas Engineering Practice Act". No warranty of any kind is made by TxDOT for any purpose whatsoever. TxDOT assumes no responsibility for the conversion of this standard to other formats or for incorrect results or damages resulting from its use.
 DATE: FILE:

DISCLAIMER: The use of this standard is governed by the "Texas Engineering Practice Act". No warranty of any kind is made by TxDOT for any purpose whatsoever. TxDOT assumes no responsibility for the conversion of this standard to other formats or for incorrect results or damages resulting from its use.

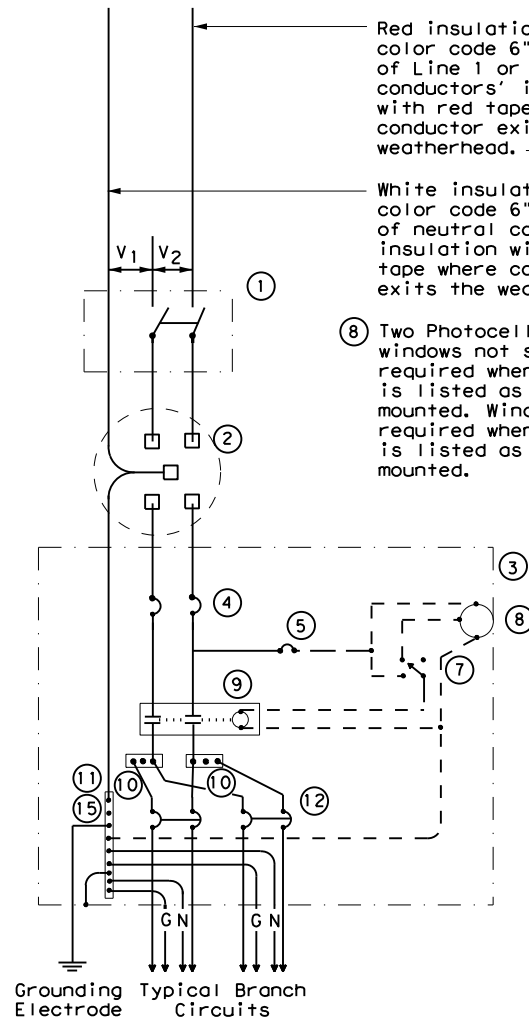

**SCHEMATIC TYPE A
THREE WIRE**

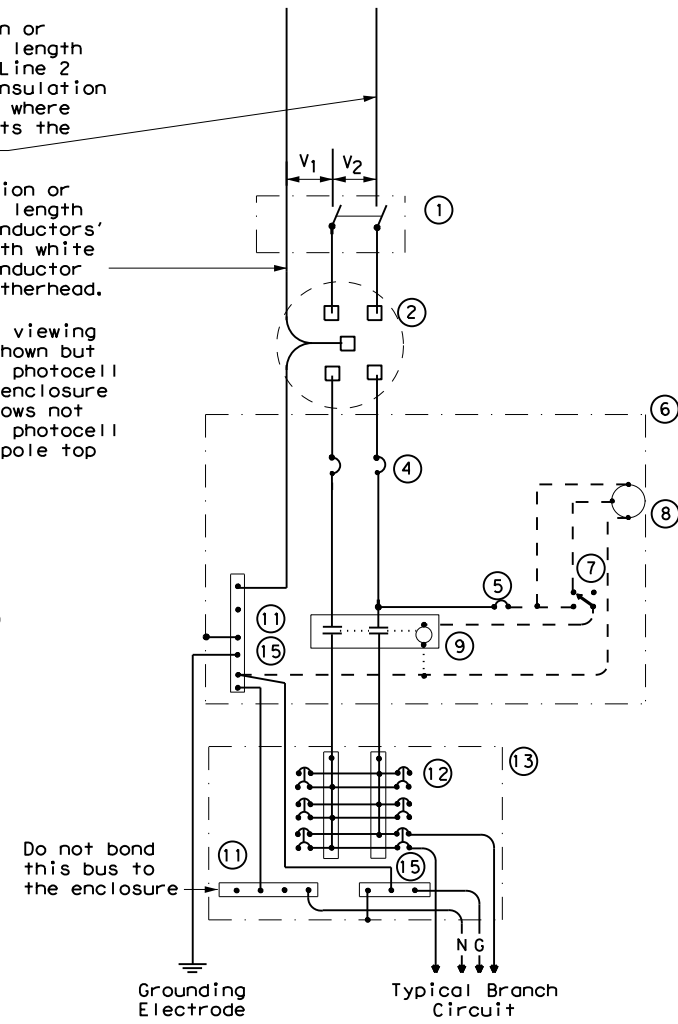

**SCHEMATIC TYPE C
THREE WIRE**

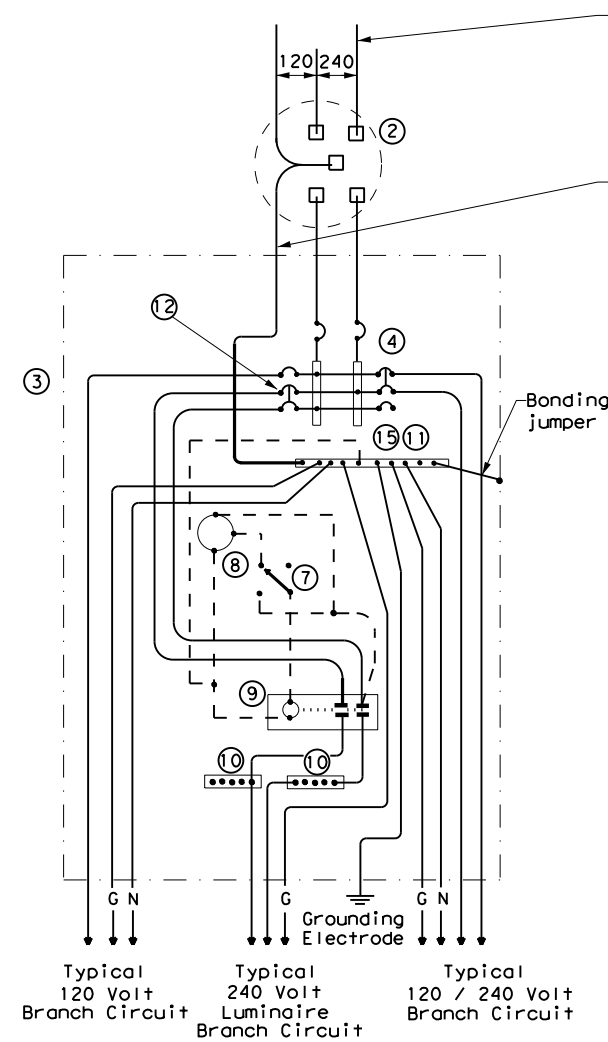

**SCHEMATIC TYPE D - CUSTOM
120/240 VOLTS - THREE WIRE**

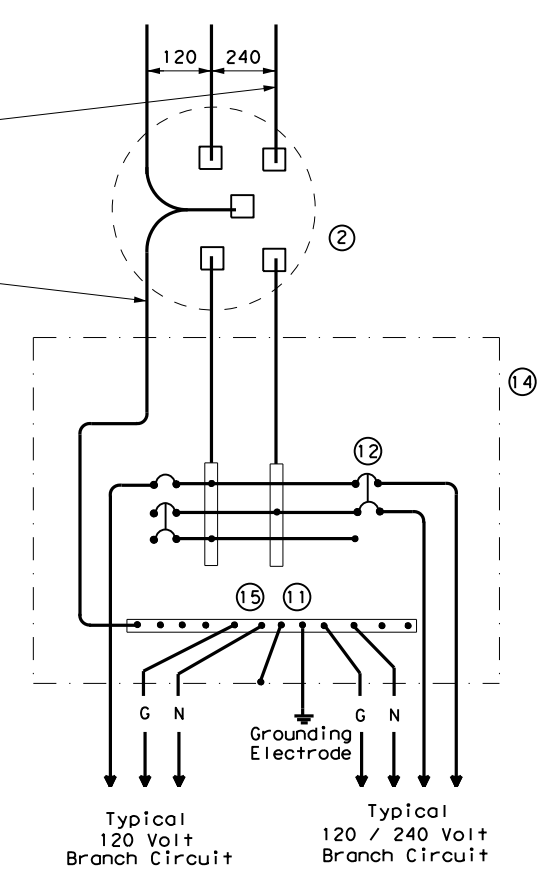

**SCHEMATIC TYPE T
120/240 VOLTS - THREE WIRE**
Galvanized steel - "Buy Off The Shelf" only. When required install photo cell top of the pole or on luminaire only, no lighting contractor will be installed.

WIRING LEGEND	
————	Power Wiring
- - - -	Control Wiring
—N—	Neutral Conductor
—G—	Equipment grounding conductor-always required

SCHEMATIC LEGEND	
1	Safety Switch (when required)
2	Meter (when required-verify with electric utility provider)
3	Service Assembly Enclosure
4	Main Disconnect Breaker (See Electrical Service Data)
5	Circuit Breaker, 15 Amp (Control Circuit)
6	Auxiliary Enclosure
7	Control Station ("H-O-A" Switch)
8	Photo Electric Control (enclosure-mounted shown)
9	Lighting Contactor
10	Power Distribution Terminal Blocks
11	Neutral Bus
12	Branch Circuit Breaker (See Electrical Service Data)
13	Separate Circuit Breaker Panelboard
14	Load Center
15	Ground Bus

				Traffic Operations Division Standard	
ELECTRICAL DETAILS SERVICE ENCLOSURE AND NOTES					
ED(6) - 14					
FILE:	ed6-14.dgn	DN:	TxDOT	CK:	TxDOT
© TxDOT	October 2014	CONT:	SECT:	JOB:	HIGHWAY:
REVISIONS		0083	03	056	SH 154, ETC
DIST:	COUNTY:	SHEET NO.			
PAR	HOPKINS, ETC	28			

DATE:
FILE:

DISCLAIMER: The use of this standard is governed by the "Texas Engineering Practice Act". No warranty of any kind is made by TxDOT for any purpose whatsoever. TxDOT assumes no responsibility for the conversion of this standard to other formats or for incorrect results or damages resulting from its use.

DATE: 12/4/2020 9:08:01 AM
 FILE: u:\tausha\dgnfiles\Our Standards 2012\Maint\ed7-14.dgn

SUPPORT TYPE STEEL POLE (SP) AND STEEL FRAME (SF)

1. Provide steel pole and steel frame supports as per TxDOT Departmental Material Specification (DMS) 11080 "Electrical Services." Mount all equipment and conduit on 12 gauge galvanized steel or stainless steel channel strut, 1 1/2 in. or 1 3/8 in. wide by 1 in. up to 3 3/4 in. deep Unistrut, Kindorf, B-line or equal. Bolt or weld all channel and hardware to vertical members as approved. Do not stack channel. File smooth and paint field cut ends of all channel with zinc-rich paint before installing.
2. Provide poles for overhead service with an eyebolt or similar fitting for attachment of the service drop to the pole in conformance with the electric utility provider's specifications.
3. Provide and install galvanized 3/4 in. x 18 in. x 4 in. (dia. x length x hook length) anchor bolts for underground service supports. Provide and install galvanized 3/4 in. x 56 in. x 4 in. anchor bolts for overhead service supports. Ensure anchor bolts have 3 in. of thread, with 3 1/4 in. to 3 1/2 in. of the exposed anchor bolt projecting above finished foundation. Provide and install leveling nuts for all anchor bolts.
4. Bond one of the anchor bolts to the rebar cage with 6 AWG bare stranded copper conductor. Use listed mechanical connectors rated for embedment in concrete. See Inset B.
5. Furnish and install rigid metallic ellis in all steel pole and steel frame foundations for all conduits entering the service from underground.
6. Use class C concrete for foundations. Ensure reinforcing steel is Grade 60 with 3" of unobstructed concrete cover.
7. Drill and tap steel poles and frames for 1/2 in. X 13 UNC tank ground fitting. For steel pole service supports, provide and install tank ground fitting 4 in. to 6 in. below electrical service enclosure. Provide properly sized hole through the bottom of the enclosure for the service grounding electrode conductor. Ensure electrical service grounding electrode conductor is as short and straight as possible from the enclosure to the tank ground fitting. For steel frame service supports, provide and install tank ground fitting on steel frame post. Install service grounding electrode conductor in a non-metallic conduit or tubing from the enclosure to the steel frame post. Connect electrical service grounding electrode conductor to the tank ground fitting. See steel frame and steel pole details and Inset A for more information. Size service entrance conduit and branch circuit conduit as shown in the plans. For underground conduit runs from the electrical service, extend RMC from the service enclosure to an RMC elbow, and then connect the schedule type and size of conduit shown in the plans. Provide and install grounding bushings where RMC terminates in the enclosure. Grounding bushings are not required when RMC is fitted into a sealing hub or threaded boss.
8. If Steel pole or frame is painted, bond each separate painted piece with a bonding jumper attached to a tapped hole.
9. Provide 1/4" - 20 machine screws for bonding. Do not use sheet metal screws. Remove all non-conductive material at contact points. Terminate bonding jumpers with listed devices. Install minimum size 6 AWG stranded copper bonding jumpers. Make up all threaded bonding connections wrench tight.
10. Avoid contact of the service drop and service entrance conductors with the metal pole to prevent abrasion of the insulated conductors.
11. Shop drawings are not required for service support structure unless specifically stated elsewhere or directed by the Engineer.

White insulation or color code 6" of neutral conductor's insulation with white tape where conductor exits weatherhead.

Red insulation or color code 6" length of Line 1 or Line 2 conductor's insulation with red tape where conductor exits the weatherhead. Conductor slack length, 12" min., 18" max.

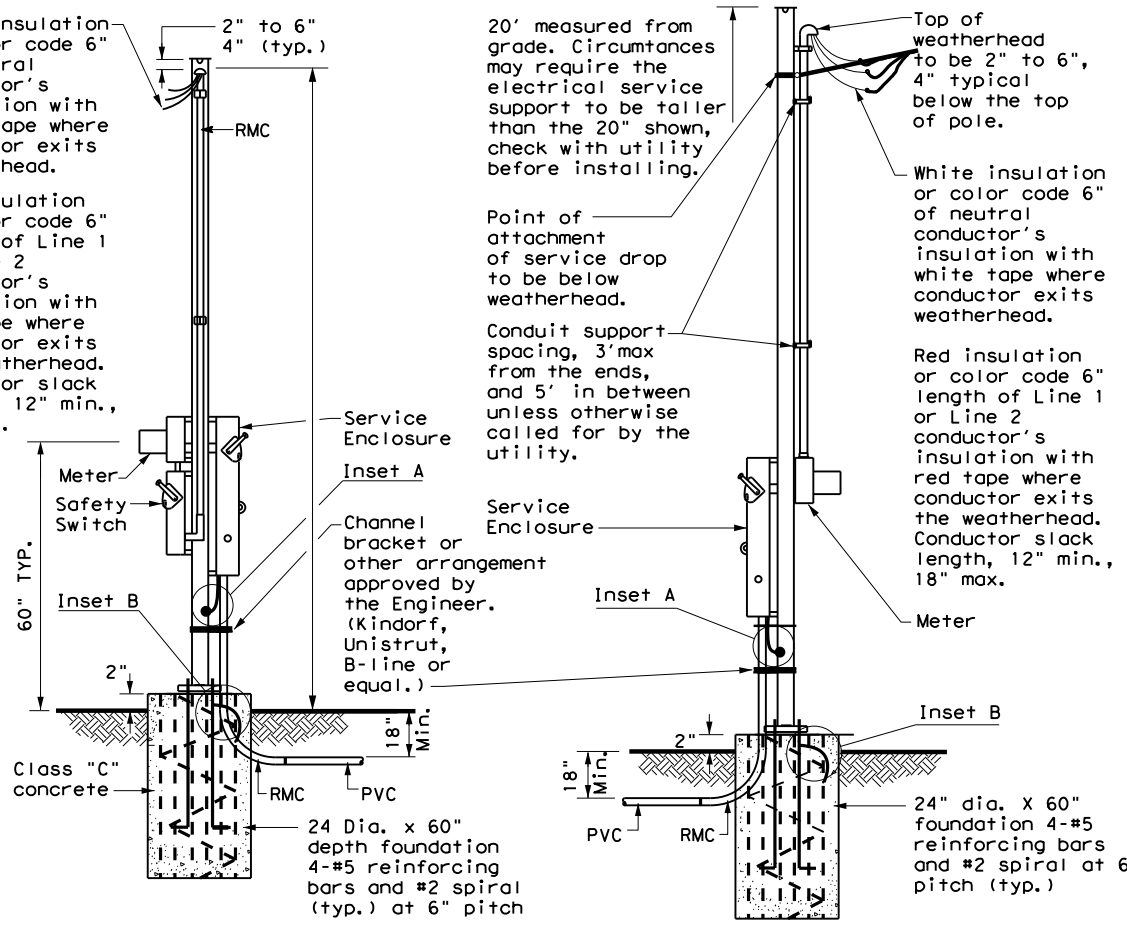

WITH SAFETY SWITCH WITHOUT SAFETY SWITCH
 SERVICE SUPPORT TYPE SP (O) - OVERHEAD SERVICE

Drill, top, and thread 1/2" X 13 UNC. Install tank ground fitting, connect electrical service grounding electrode conductor. See Note 7.

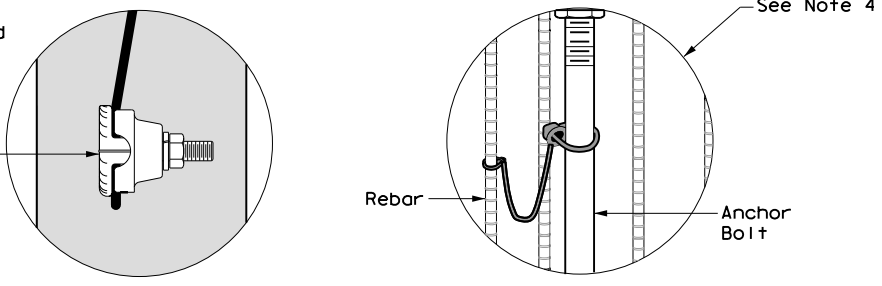

FRONT VIEW INSET A INSET B

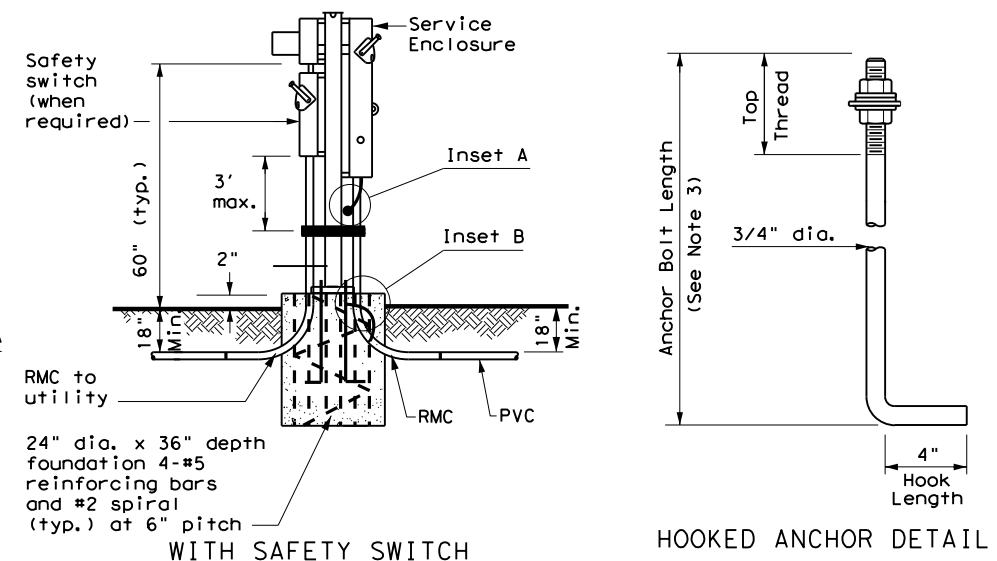

WITH SAFETY SWITCH HOOKED ANCHOR DETAIL
 SERVICE SUPPORT TYPE SP (U) - UNDERGROUND SERVICE

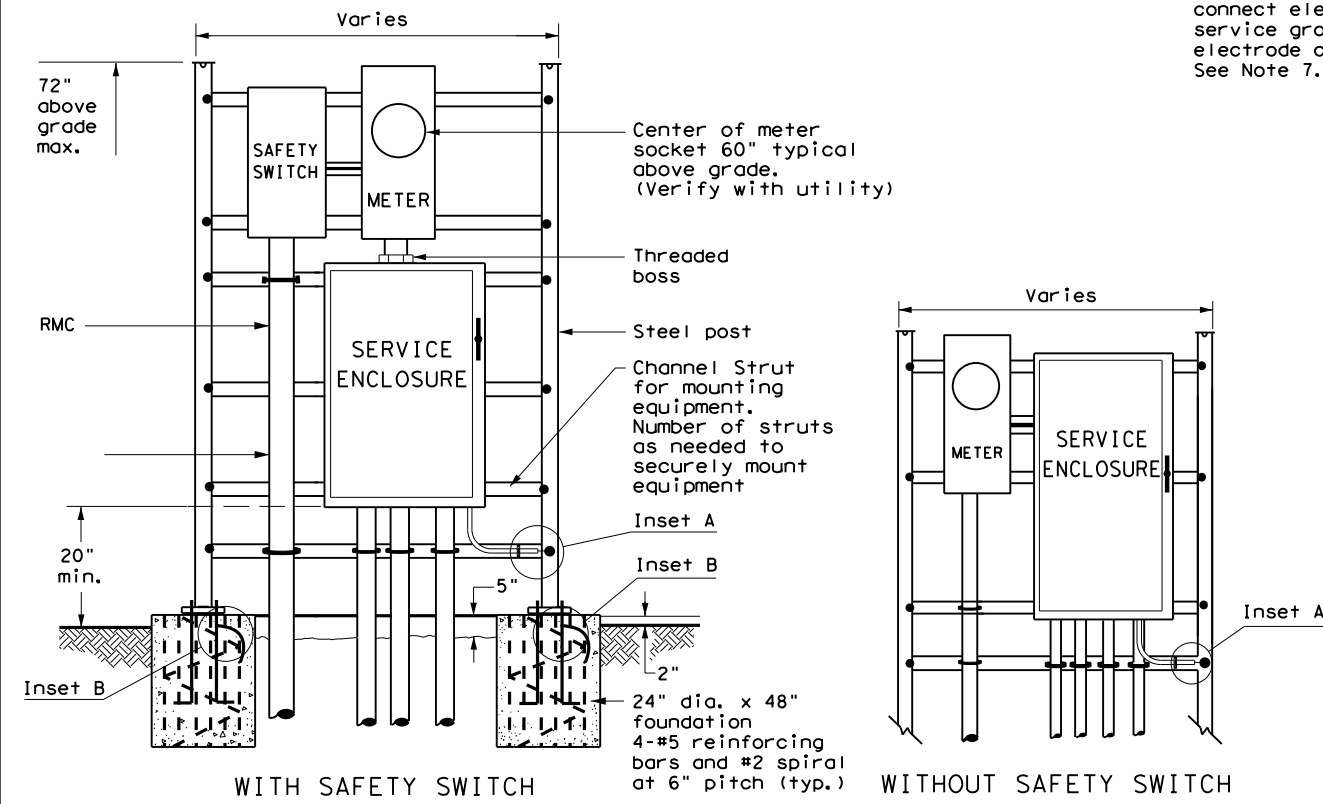

WITH SAFETY SWITCH WITHOUT SAFETY SWITCH
 FRONT VIEW
 SERVICE SUPPORT TYPE SF (U) - UNDERGROUND SERVICE

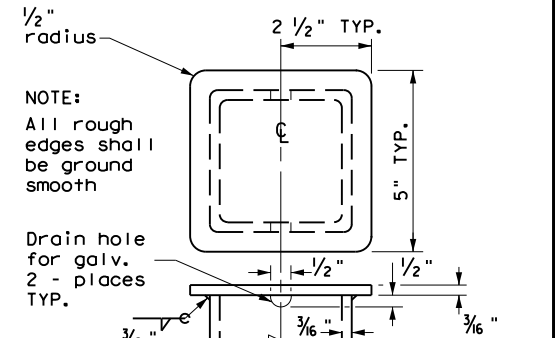

POLE TOP PLATE

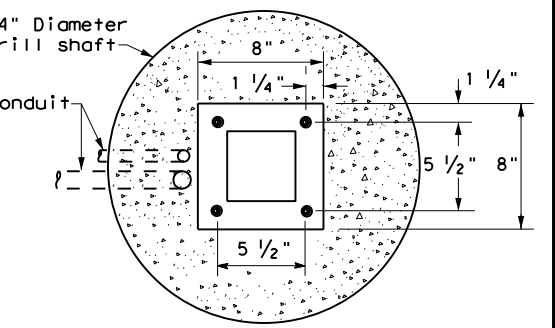

BASE PLATE DETAIL

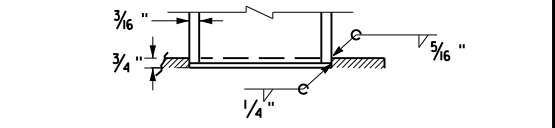

BOTTOM OF POLE

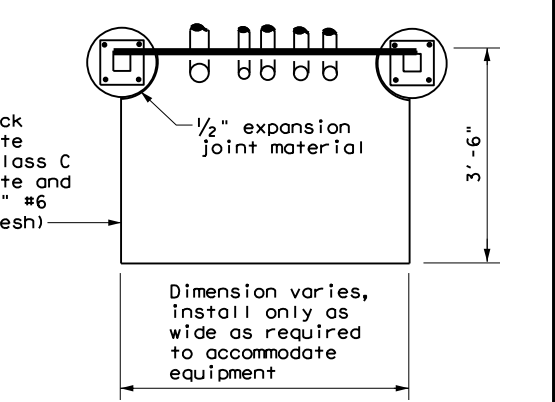

TOP VIEW
 SERVICE SUPPORT TY SF (O) & SF (U)

		Traffic Operations Division Standard	
ELECTRICAL DETAILS SERVICE SUPPORT TYPES SF & SP ED(7)-14			
FILE: ed7-14.dgn	DW: TxDOT	CK: TxDOT	DW: TxDOT
©TxDOT October 2014	CON: 0083	SECT: 03	JOB: 056
REVISIONS	PAR	COUNTY: HOPKINS, ETC	SHEET NO.: 29

DISCLAIMER: The use of this standard is governed by the "Texas Engineering Practice Act". No warranty of any kind is made by TxDOT for any purpose whatsoever. TxDOT assumes no responsibility for the conversion of this standard to other formats or for incorrect results or damages resulting from its use.

DATE: 12/4/2020 9:08:06 AM
 FILE: u:\tausha\dgnfiles\Our Standards_2012\Maint\ed8-14.dgn

TRAFFIC SIGNAL NOTES

1. Do not pass luminaire conductors through the signal controller cabinet.
2. Include an equipment grounding conductor in all conduits throughout the electrical system. Bond all exposed metal parts to the grounding conductor.
3. Provide roadway luminaires, when required, in accordance with the material and construction sections of Item 610, "Roadway Illumination Assemblies," except for performance testing of luminaires. Test installed roadway luminaires for proper operation as a part of the associated traffic signal system test.
4. If internally illuminated street name signs are approved for use, ground the fixture to the pole with a 12 AWG green XHHW conductor.
5. Bond anchor bolts to rebar cage in two locations using #3 bars or 6 AWG stranded copper conductors. Use listed mechanical connectors rated for embedment in concrete. See TxDOT standard TS-FD for further details.
6. Drill and tap signal poles for 1/2 in. X 13 UNC tank ground fitting. Provide and install tank ground fitting 4 in. to 6 in. directly below electrical service enclosure. Provide properly sized hole through the bottom of the enclosure for the service grounding electrode conductor. Connect the electrical service grounding electrode conductor to the tank ground fitting. Ensure electrical service grounding electrode conductor is as short and straight as possible from the enclosure to the tank ground fitting. See Inset A detail for further information. Size service entrance conduit and branch circuit conduit as shown in the plans.
7. Mount electrical service enclosure and meter to signal pole with stainless steel bands. Ensure bands are a minimum width of 3/4 in. Secure enclosures to bands using two-bolt brackets. Install brackets near top and bottom of each enclosure. Install properly sized stainless steel washers on each bolt in the enclosure. Band or drill and tap properly sized stand-off straps to signal pole for attaching conduit.
8. Conduct pull tests and insulation resistance tests on all illumination and power conductors as required in Item 620 "Electrical Conductors" and ED(3). To prevent electronics damage, do not conduct insulation resistance tests on traffic signal cables after termination.
9. Lock all enclosures and bolt down all ground box covers before applying power to the signal installation.
10. Terminate conduits entering the top of enclosures with a conduit-sealing hub or threaded boss such as meter hub. Install a grounding bushing on all metal conduits not connected to conduit-sealing hub or threaded boss. Bond the grounding bushing to the ground bus with a bonding jumper. Seal all conduits entering enclosures with duct seal or expanding foam. Do not use silicone to seal conduit ends.
11. For all conduits, ensure the burial depth is a minimum of 18". Ensure the minimum burial depth for conduit placed under a roadway is 24".

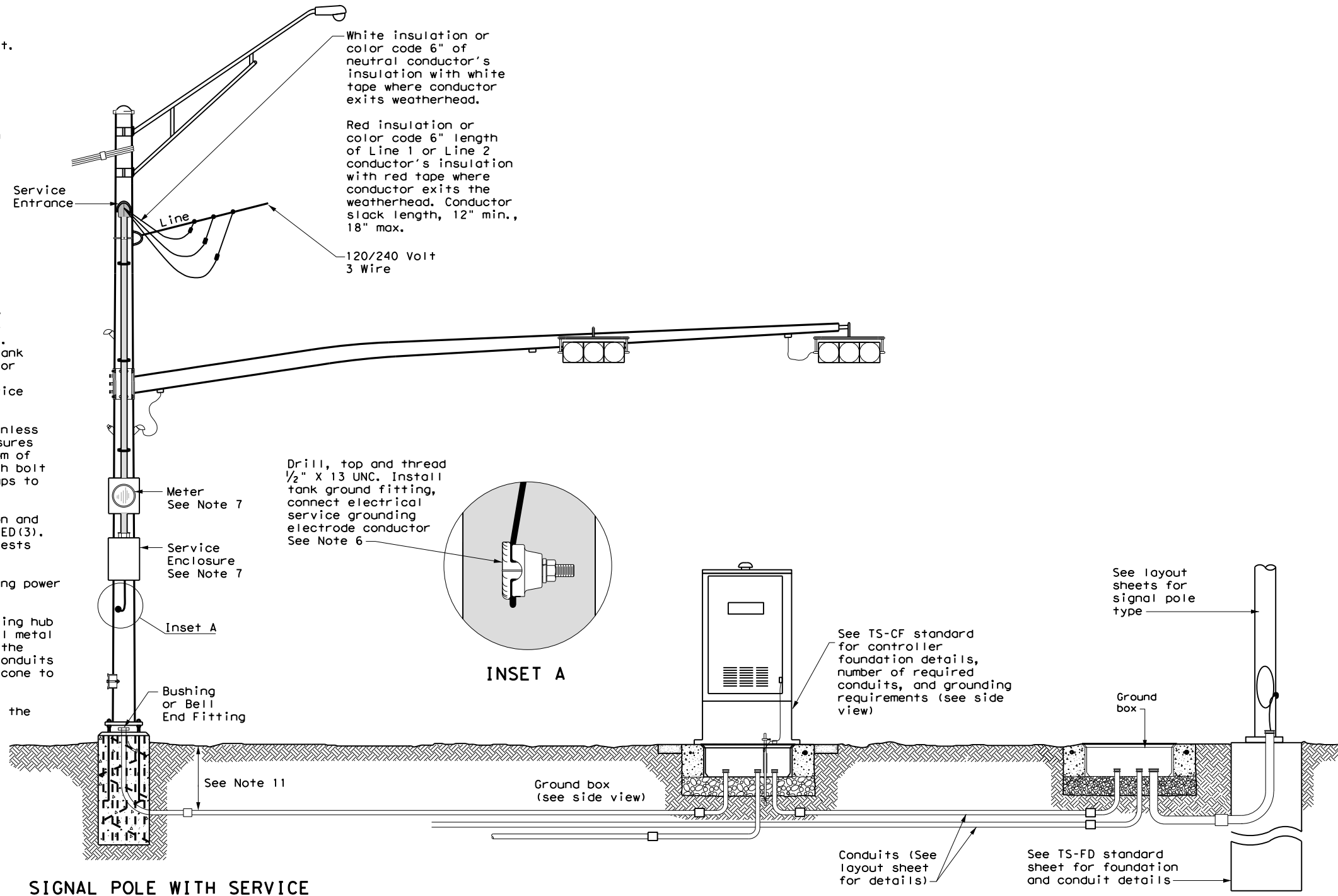

SIGNAL POLE WITH SERVICE

Type T electrical service mounted on signal pole shown as an example. See electrical details, layout sheets, and electrical service data chart for additional details.

SIGNAL CONTROLLER FRONT VIEW

SIGNAL POLE

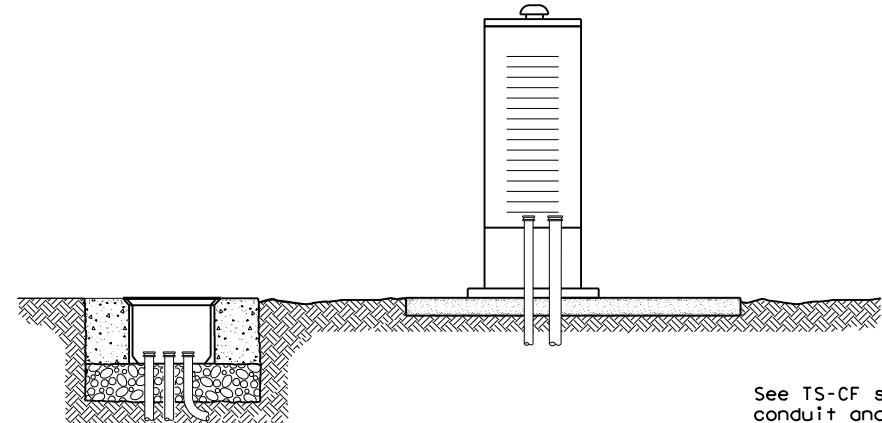

SIGNAL CONTROLLER SIDE VIEW

See TS-CF standard for conduit and grounding requirements. See layout sheets for ground box locations and any additional conduits that are required.

		Traffic Operations Division Standard	
<h2>ELECTRICAL DETAILS TYPICAL TRAFFIC SIGNAL SYSTEM DETAILS</h2> <h3>ED(8) - 14</h3>			
FILE: ed8-14.dgn	DN: TxDOT	CK: TxDOT	DW: TxDOT
© TxDOT October 2014	CONT: 0083	SECT: 03	JOB: 056
REVISIONS	SH: 154	ETC	
DIST: PAR	COUNTY: HOPKINS, ETC	SHEET NO.: 30	

DISCLAIMER: The use of this standard is governed by the "Texas Engineering Practice Act". No warranty of any kind is made by TxDOT for any purpose whatsoever. TxDOT assumes no responsibility for the conversion of this standard to other formats or for incorrect results or damages resulting from its use.

PEDESTAL SERVICE NOTES

1. Manufacture pedestal electrical services in accordance with Departmental Material Specifications (DMS) 11080 "Electrical Services", 11085 "Electrical Services-Pedestal (PS)" and Item 628 "Electrical Services." Provide pedestal electrical services as listed on the Material Producers List (MPL) on the Department's web site under "Roadway Illumination and Electrical Supplies," Item 628. Ensure all mounting hardware and installation details of services meet utility company specifications. Contact the local utility company for approval of pedestal details prior to installing the electrical pedestal service. Submit any changes required by the utility company prior to manufacturing the pedestal enclosure.
2. When a meter socket is required, provide a socket with a minimum 100 amp rating that complies with local utility requirements.
3. Provide Class A or C concrete for pedestal service foundations in accordance with Item 420, "Concrete Substructures," except that concrete will not be paid for directly but is considered subsidiary to Item 628.
4. Provide #4 reinforcing steel for foundations in accordance with Item 440, "Reinforcement for Concrete."
5. Install 1/2 in. X 2 1/16 in. minimum length concrete single expansion type anchors for mounting pedestal enclosure to foundation. Anchor location to match mounting holes in each corner of enclosure. Secure each of the four corners of the pedestal enclosure to the anchors in the foundation with a 1/2 in. galvanized or stainless steel machine thread bolt, a properly sized locknut and a flat washer.
6. Finish top of concrete foundation in a neat and workmanlike manner. If leveling washers are used, ensure no more than 1/8 in. gap at any corner. Do not exceed a maximum dip or rise in the foundation of 1/8 in. per foot. When properly installed, ensure the top of the service enclosure is level front to back and side to side within 1/4 in. Repair rocking or movement of the service enclosure at no additional cost to the department.
7. Do not use liquidtight flexible metal conduit (LFMC) on pedestal type services.
8. Ensure all elbows in the foundation are sized as per utility provider's conduit requirements for underground conduit and feeders. PVC extensions may be installed provided the ends of the rigid metal conduits are more than 2 in. below the top of the concrete foundation. Where extension conduits are metal, grounding bushings must be installed with a bonding jumper properly terminated.

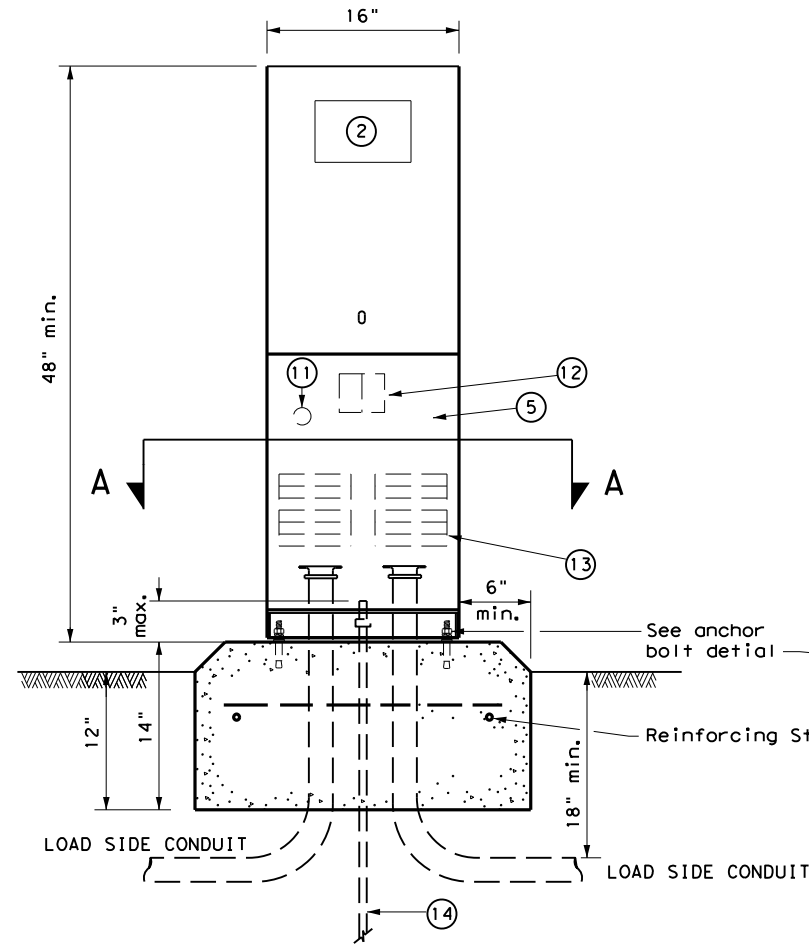

FRONT VIEW

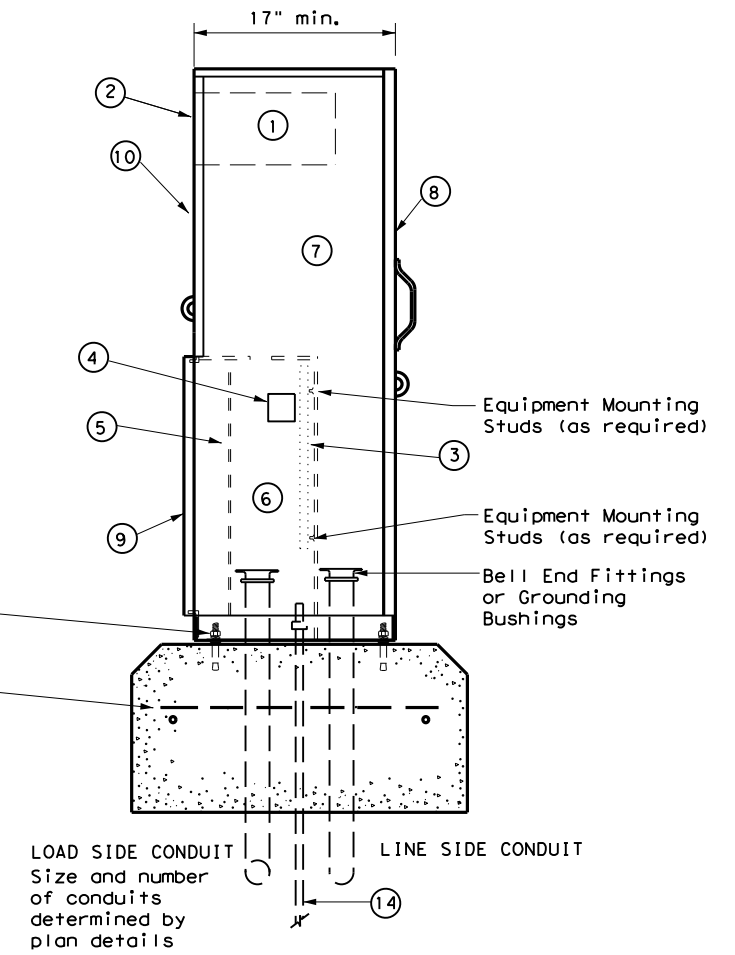

SIDE VIEW

TYPE C shown, TYPE A similar except that TYPE A shall have individual circuit breakers (CB) mounted on an equipment mounting panel. CB Handles shall protrude through hinged deadfront trim.

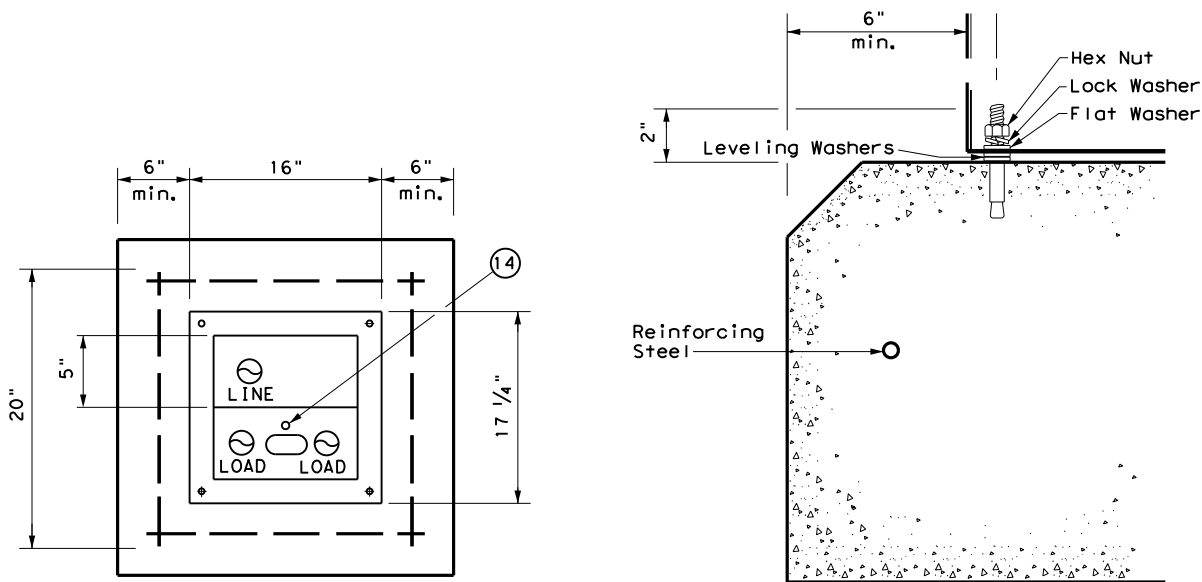

SECTION A-A

ANCHOR BOLT DETAIL

LEGEND

1	Meter Socket, (when required)
2	Meter Socket Window, (when required)
3	Equipment Mounting Panel
4	Photo Electric Control Window, (When required)
5	Hinged Deadfront Trim
6	Load Side Conduit Trim
7	Line Side Conduit Area
8	Utility Access Door, with handle
9	Pedestal Door
10	Hinged Meter Access
11	Control Station (H-O-A Switch)
12	Main Disconnect
13	Branch Circuit Breakers
14	Copper Clad Ground Rod - 5/8" X 10'

		Traffic Operations Division Standard	
ELECTRICAL DETAILS ELECTRICAL SERVICE SUPPORT PEDESTAL SERVICE TYPE PS			
ED(9) - 14			
FILE: ed9-14.dgn	DN: TxDOT	CK: TxDOT	DW: TxDOT
© TxDOT October 2014	CONT	SECT	JOB
REVISIONS	0083	03	056 SH 154, ETC
	DIST	COUNTY	SHEET NO.
	PAR	HOPKINS, ETC	31

DATE: FILE:

DISCLAIMER: The use of this standard is governed by the "Texas Engineering Practice Act". No warranty of any kind is made by TxDOT for any purpose whatsoever. TxDOT assumes no responsibility for the conversion of this standard to other formats or for incorrect results or damages resulting from its use.

DATE: 12/4/2020 9:08:20 AM
 FILE: U:\TAUSA\Drawings\Our Standards 2012\Maint\wzbt-13.dgn

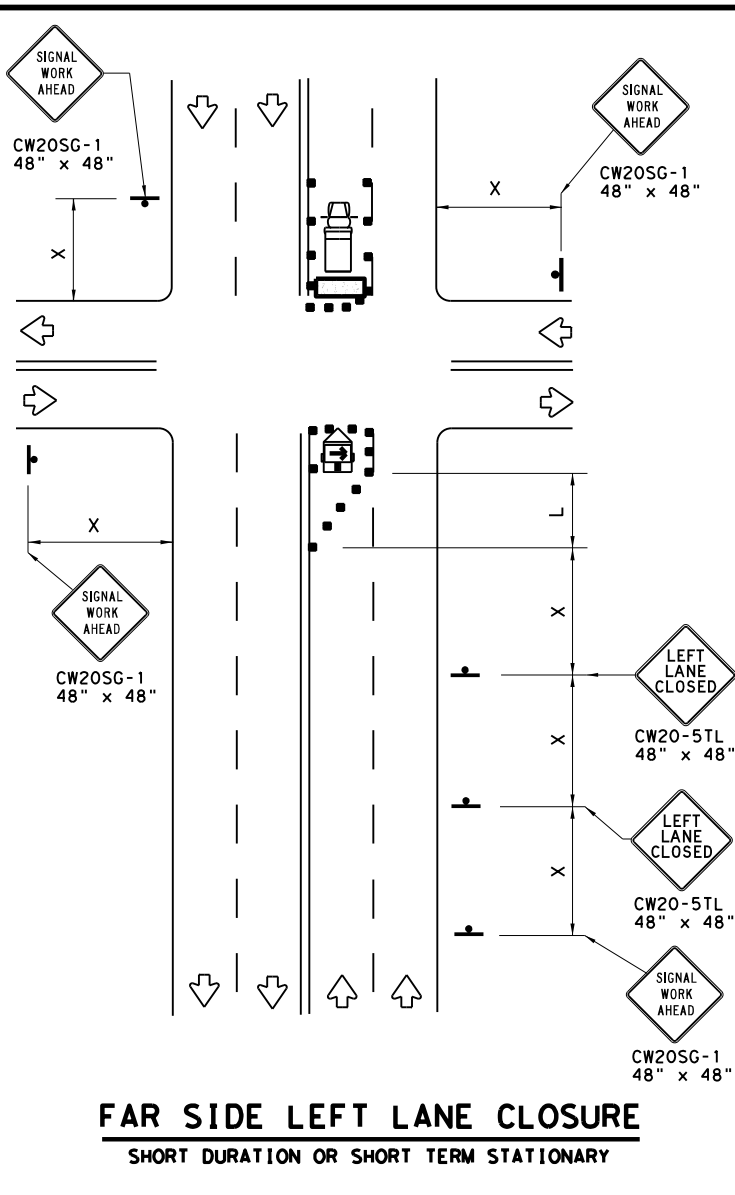
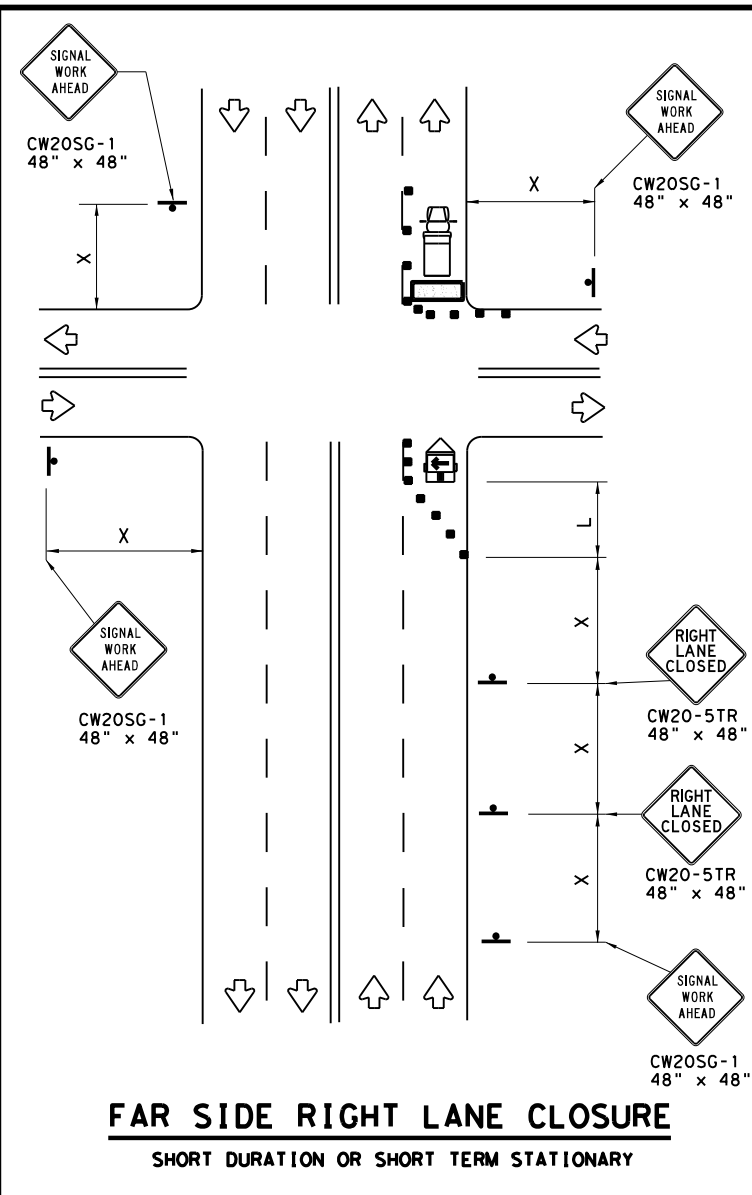
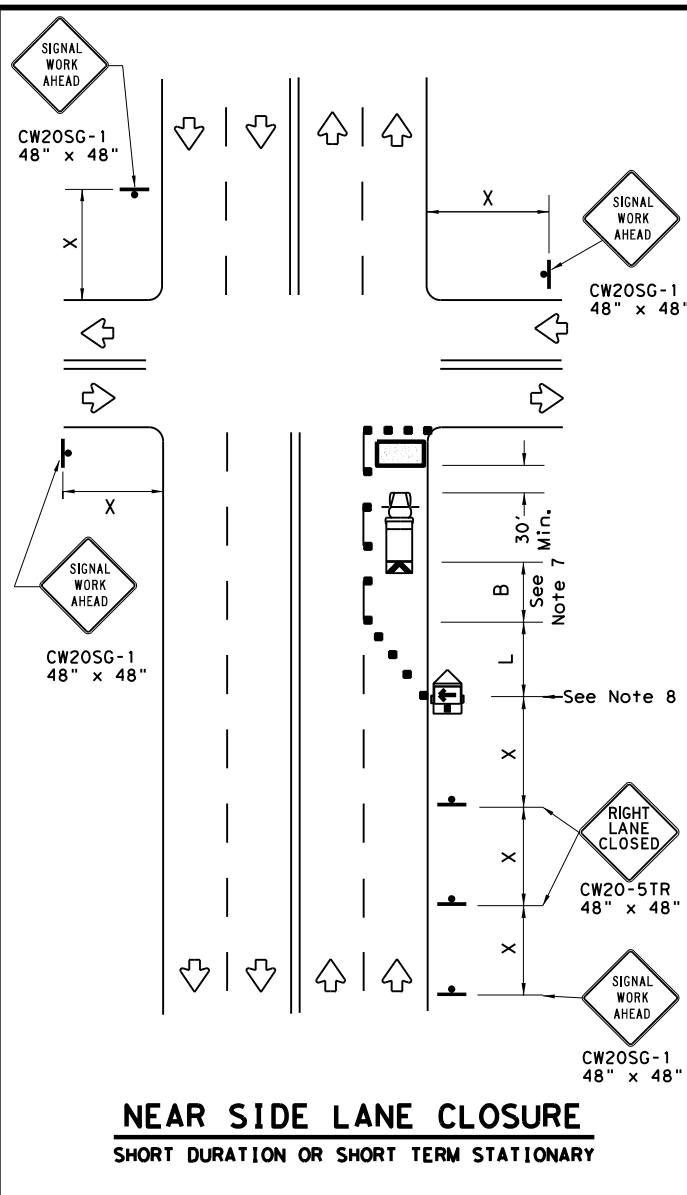

LEGEND			
	Type 3 Barricade		Channelizing Devices
	Heavy Work Vehicle		Truck Mounted Attenuator (TMA)
	Trailer Mounted Flashing Arrow Board		Portable Changeable Message Sign (PCMS)
	Sign		Traffic Flow
	Flag		Flagger

Posted Speed *	Formula	Minimum Desirable Taper Lengths **			Suggested Maximum Spacing of Channelizing Devices		Minimum Sign Spacing "X" Distance	Suggested Longitudinal Buffer Space "B"
		10' Offset	11' Offset	12' Offset	On a Taper	On a Tangent		
30	$L = \frac{WS^2}{60}$	150'	165'	180'	30'	60'	120'	90'
35		205'	225'	245'	35'	70'	160'	120'
40		265'	295'	320'	40'	80'	240'	155'
45	L = WS	450'	495'	540'	45'	90'	320'	195'
50		500'	550'	600'	50'	100'	400'	240'
55		550'	605'	660'	55'	110'	500'	295'
60		600'	660'	720'	60'	120'	600'	350'
65		650'	715'	780'	65'	130'	700'	410'
70		700'	770'	840'	70'	140'	800'	475'
75		750'	825'	900'	75'	150'	900'	540'

* Conventional Roads Only
 ** Taper lengths have been rounded off.
 L=Length of Taper (FT) W=Width of Offset (FT) S=Posted Speed (MPH)

WORKERS IN BUCKET TRUCKS SHALL NOT WORK ABOVE OPEN LANES OF TRAFFIC.

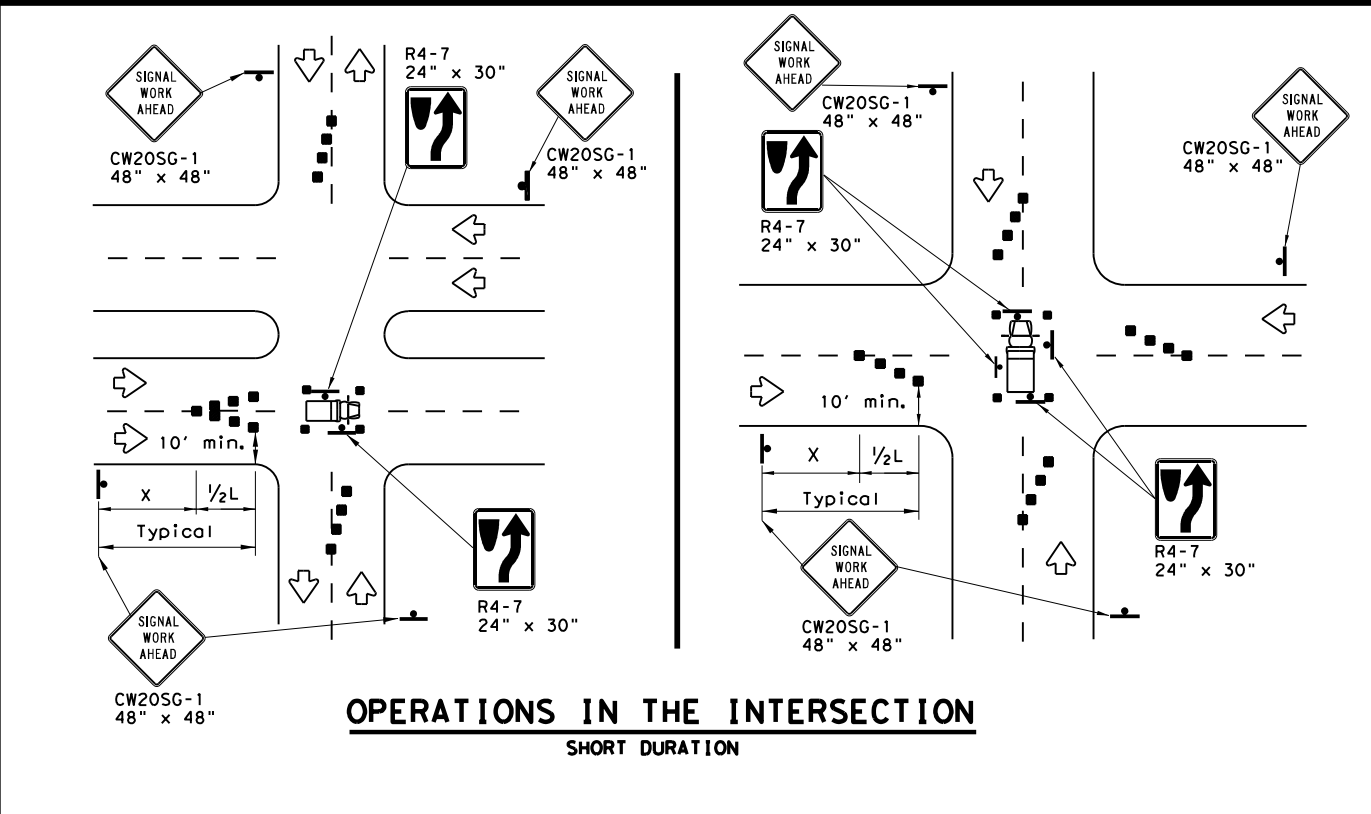

GENERAL NOTES

- The minimum size channelizing device is the 28" cone. 42" Two-piece cones, drums, vertical panels or barricades will be required when the device must be left unattended at night.
- Obstructions or hazards at the work area shall be clearly marked and delineated at all times.
- Flaggers and Flagger Symbol (CW20-7) signs may be required according to field conditions.
- Vehicles parked in roadway shall be equipped with at least two high intensity rotating, flashing, oscillating or strobe type lights.
- High level warning devices (flag trees) may be used at corners of the vehicle.
- When work operations are performed on existing signals, the signals may be placed in flashing red mode when approved by the engineer. If existing signals do not have power, All-Way Stop (R1-1 and R1-3P) signs may be implemented when approved by the engineer.
- For Short-Term Stationary work the buffer space "B" from the above table should be used if field conditions permit. For Short Duration (less than 1 hour) any buffer space provided will enhance the safety of the setup.
- The arrow board at this location may be omitted for Short Duration work if the work vehicle has an arrow board in operation. As an option, the arrow board may be placed at the end of the taper in the closed lane if space is not available at the beginning of the taper.
- Signs and devices for the NEAR SIDE LANE CLOSURE may be altered for a left lane closure by using a LEFT LANE CLOSED (CW20-5TL) and adding channelizing devices on the centerline to protect the work space from opposing traffic.



TRAFFIC SIGNAL WORK TYPICAL DETAILS

WZ(BTS-1)-13

FILE: wzbt-13.dgn	DN: TxDOT	CR: TxDOT	OW: TxDOT	CK: TxDOT
© TxDOT April 1992	CONT	SECT	JOB	HIGHWAY
REVISIONS	0083	03	056	SH 154, ETC
2-98 10-99 7-13	DIST	COUNTY	SHEET NO.	
4-98 3-03	PAR	HOPKINS, ETC	32	

DISCLAIMER: The use of this standard is governed by the "Texas Engineering Practice Act". No warranty of any kind is made by TxDOT for any purpose whatsoever. TxDOT assumes no responsibility for the conversion of this standard to other formats or for incorrect or damages resulting from its use.

DATE: 12/4/2020 9:08:21 AM
 FILE: U:\TAUSHA\dgnfiles\Our Standards 2012\Maint\wzlbs-13.dgn

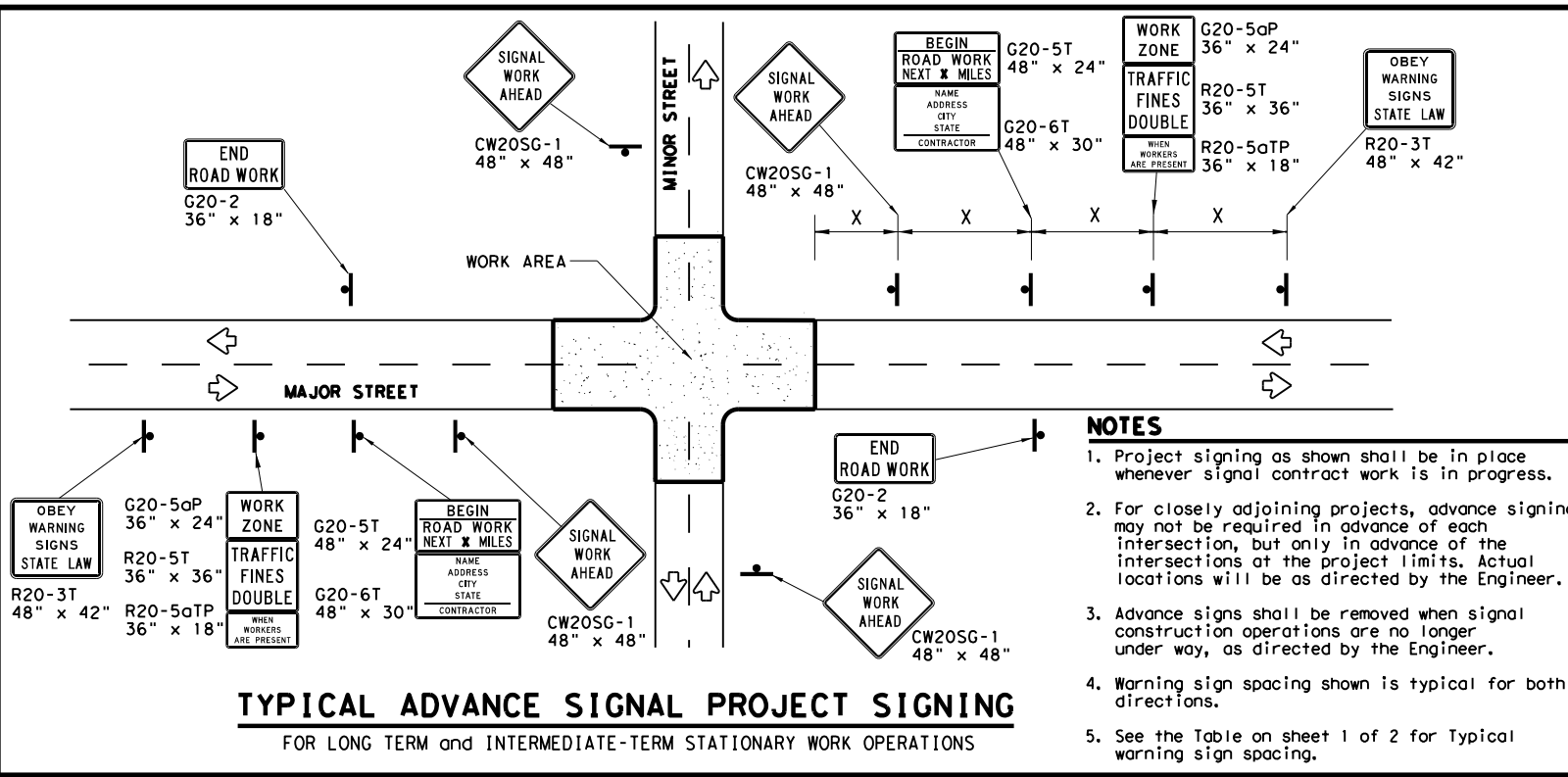

TYPICAL ADVANCE SIGNAL PROJECT SIGNING
 FOR LONG TERM and INTERMEDIATE-TERM STATIONARY WORK OPERATIONS

- NOTES**
1. Project signing as shown shall be in place whenever signal contract work is in progress.
 2. For closely adjoining projects, advance signing may not be required in advance of each intersection, but only in advance of the intersections at the project limits. Actual locations will be as directed by the Engineer.
 3. Advance signs shall be removed when signal construction operations are no longer under way, as directed by the Engineer.
 4. Warning sign spacing shown is typical for both directions.
 5. See the Table on sheet 1 of 2 for Typical warning sign spacing.

GENERAL NOTES FOR WORK ZONE SIGNS

1. Signs shall be installed and maintained in a straight and plumb condition.
2. Wooden sign posts shall be painted white.
3. Barricades shall NOT be used as sign supports.
4. Nails shall NOT be used to attach signs to any support.
5. All signs shall be installed in accordance with the plans or as directed by the Engineer.
6. The Contractor shall furnish the sign design shown in the plans or in the "Standard Highway Sign Designs for Texas" (SHSD).
7. The Contractor shall furnish sign supports and substrates listed in the "Compliant Work Zone Traffic Control Device List" (CWZTCD), installed as per the manufacturer's recommendations.
8. Temporary signs that have damaged or cracked substrates and/or damaged or marred reflective sheeting shall be replaced as directed by the Engineer.
9. Identification markings may be shown only on the back of the sign substrate. The maximum height of letters and/or company logos used for identification shall be 1".
10. Damaged wood posts shall be replaced. Splicing wood posts will not be allowed.

DURATION OF WORK

1. Work zone durations are defined in Part 6, Section 60.02 of the Texas Manual on Uniform Traffic Control Devices (TMUTCD).

SIGN MOUNTING HEIGHT

1. Sign height of Long-term/Intermediate-term warning signs shall be as shown on Figure 6F-1 of the TMUTCD.
2. Sign height of Short-term/Short Duration warning signs shall be as shown on Figure 6F-2 of the TMUTCD.
3. Regulatory signs shall be mounted at least 7 feet, but not more than 9 feet, above the paved surface regardless of work duration.

REMOVING OR COVERING

1. When sign messages may be confusing or do not apply, the signs shall be removed or completely covered, unless otherwise approved by the Engineer.
2. When signs are covered, the material used shall be opaque, such as heavy mil black plastic, or other materials which will cover the entire sign face and maintain their opaque properties under automobile headlights at night without damaging the sign sheeting. Burlap, or heavy materials such as plywood or aluminum shall not be used to cover signs.
3. Duct tape or other adhesive material shall NOT be affixed to a sign face.
4. Signs and anchor stubs shall be removed and holes back filled upon completion of the work.

REFLECTIVE SHEETING

1. All signs shall be retroreflective and constructed of sheeting meeting the requirements of the DMS and color usage table shown on this sheet.

SIGN SUPPORT WEIGHTS

1. Weights used to keep signs from turning over should be sandbags filled with dry, cohesionless material.
2. The sandbags will be tied shut to keep the sand from spilling and to maintain a constant weight.
3. Rock, concrete, iron, steel or other solid objects will not be permitted for use as sign support weights.
4. Sandbags should weigh a minimum of 35 lbs and a maximum of 50 lbs.
5. Sandbags shall be made of a durable material that tears upon vehicular impact. Rubber, such as tire inner tubes, shall not be used.
6. Rubber ballasts designed for channelizing devices should not be used for ballast on portable sign supports. Sign supports designed and manufactured with rubber bases may be used when shown on the CWZTCD list.
7. Sandbags shall only be placed along or laid over the base supports of the traffic control device and shall not be suspended above ground level or hung with rope, wire, chains or other fasteners. Sandbags shall be placed along the length of the skids to weigh down the sign support.
8. Sandbags shall NOT be placed under the skid and shall not be used to level sign supports placed on slopes.

LEGEND

	Sign
	Channelizing Devices
	Type 3 Barricade

DEPARTMENTAL MATERIAL SPECIFICATIONS

SIGN FACE MATERIALS	DMS-8300
FLEXIBLE ROLL-UP REFLECTIVE SIGNS	DMS-8310

COLOR	USAGE	SHEETING MATERIAL
ORANGE	BACKGROUND	TYPE B _{FL} OR TYPE C _{FL} SHEETING
WHITE	BACKGROUND	TYPE A SHEETING
BLACK	LEGEND & BORDERS	ACRYLIC NON-REFLECTIVE SHEETING

Only pre-qualified products shall be used. A copy of the "Compliant Work Zone Traffic Control Devices List" (CWZTCD) describes pre-qualified products and their sources and may be found at the following web address:
http://www.txdot.gov/txdot_library/publications/construction.htm

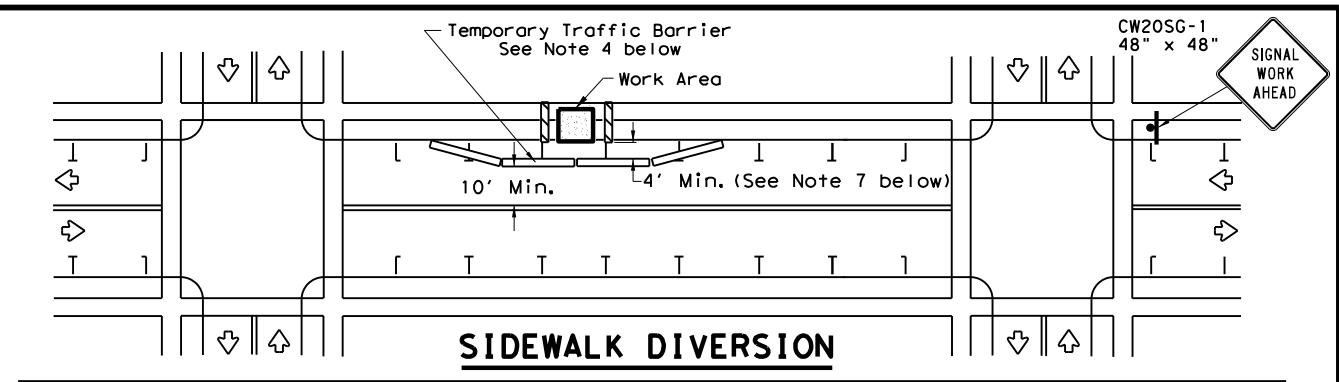

SIDEWALK DIVERSION

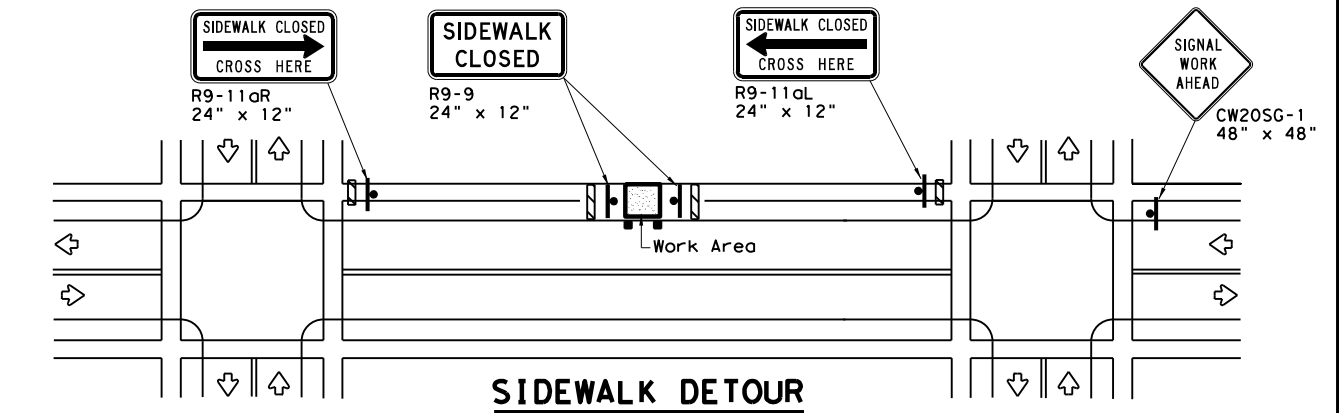

SIDEWALK DETOUR

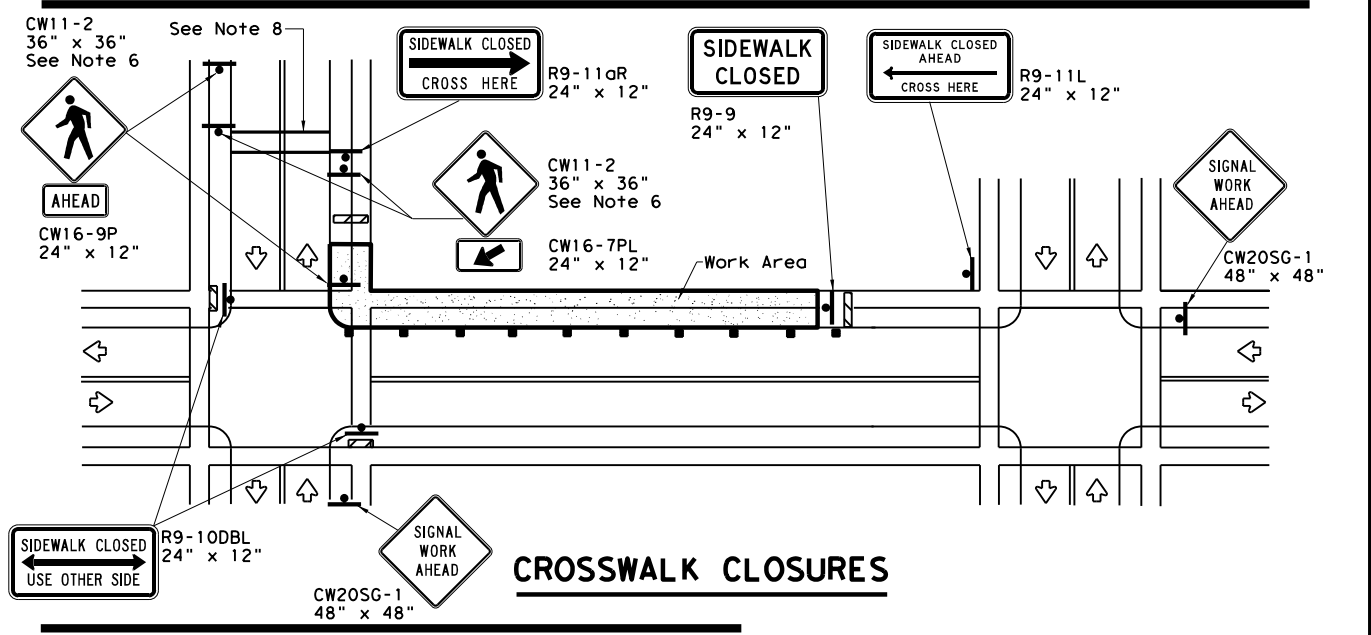

CROSSWALK CLOSURES

PEDESTRIAN CONTROL

1. Holes, trenches or other hazards shall be adequately protected by covering, delineating or surrounding the hazard with orange plastic pedestrian fencing or longitudinal channelizing devices, or as directed by the Engineer.
2. "CROSSWALK CLOSURES" as detailed above will require the Engineer's approval prior to installation.
3. R9 series signs shown may be placed on supports detailed on the BC standards or CWZTCD list, or when fabricated from approved lightweight plastic substrates, they may be mounted on top of a plastic drum at or near the location shown.
4. For speeds less than 45 mph longitudinal channelizing devices may be used instead of traffic barriers when approved by the Engineer. Attenuation of blunt ends and installation of water filled devices shall be as per BC(9) and manufacturer's recommendations.
5. Location of devices are for general guidance. Actual device spacing and location must be field adjusted to meet actual conditions.
6. Where pedestrians with visual disabilities normally use the closed sidewalk Detectable Pedestrian Barricades should be used instead of the Type 3 Barricades shown.
7. The width of existing sidewalk should be maintained if practical.
8. Pavement markings for mid-block crosswalks shall be paid for under the appropriate bid items.
9. When crosswalks or other pedestrian facilities are closed or relocated, temporary facilities shall be detectable and shall include accessibility features consistent with the features present in the existing pedestrian facility.

SHEET 2 OF 2

Texas Department of Transportation
 Traffic Operations Division Standard

TRAFFIC SIGNAL WORK BARRICADES AND SIGNS

WZ (BTS-2) - 13

FILE: wzlbs-13.dgn	DN: TxDOT	CR: TxDOT	OW: TxDOT	CK: TxDOT
© TxDOT April 1992	CONT	SECT	JOB	HIGHWAY
REVISIONS	0083	03	056	SH 154, ETC
2-98 10-99 7-13	DIST	COUNTY	SHEET NO.	
4-98 3-03	PAR	HOPKINS, ETC	33	

DISCLAIMER: The use of this standard is governed by the "Texas Engineering Practice Act". No warranty of any kind is made by TxDOT for any purpose whatsoever. TxDOT assumes no responsibility for the conversion of this standard to other formats or for incorrect results or damages resulting from its use.

BARRICADE AND CONSTRUCTION (BC) STANDARD SHEETS GENERAL NOTES:

- The Barricade and Construction Standard Sheets (BC sheets) are intended to show typical examples for placement of temporary traffic control devices, construction pavement markings, and typical work zone signs. The information contained in these sheets meet or exceed the requirements shown in the "Texas Manual on Uniform Traffic Control Devices" (TMUTCD).
- The development and design of the Traffic Control Plan (TCP) is the responsibility of the Engineer.
- The Contractor may propose changes to the TCP that are signed and sealed by a licensed professional engineer for approval. The Engineer may develop, sign and seal Contractor proposed changes.
- The Contractor is responsible for installing and maintaining the traffic control devices as shown in the plans. The Contractor may not move or change the approximate location of any device without the approval of the Engineer.
- Geometric design of lane shifts and detours should, when possible, meet the applicable design criteria contained in manuals such as the American Association of State Highway and Transportation Officials (AASHTO), "A Policy on Geometric Design of Highways and Streets," the TxDOT "Roadway Design Manual" or engineering judgment.
- When projects abut, the Engineer(s) may omit the END ROAD WORK, TRAFFIC FINES DOUBLE, and other advance warning signs if the signing would be redundant and the work areas appear continuous to the motorists. If the adjacent project is completed first, the Contractor shall erect the necessary warning signs as shown on these sheets, the TCP sheets or as directed by the Engineer. The BEGIN ROAD WORK NEXT X MILES sign shall be revised to show appropriate work zone distance.
- The Engineer may require duplicate warning signs on the median side of divided highways where median width will permit and traffic volumes justify the signing.
- All signs shall be constructed in accordance with the details found in the "Standard Highway Sign Designs for Texas," latest edition. Sign details not shown in this manual shall be shown in the plans or the Engineer shall provide a detail to the Contractor before the sign is manufactured.
- The temporary traffic control devices shown in the illustrations of the BC sheets are examples. As necessary, the Engineer will determine the most appropriate traffic control devices to be used.
- As shown on BC(2), the OBEY WARNING SIGNS STATE LAW sign, STAY ALERT TALK OR TEXT LATER (see Sign Detail G20-10T) and the WORK ZONE TRAFFIC FINES DOUBLE sign with plaque shall be erected in advance of the CSJ limits. However, the TRAFFIC FINES DOUBLE sign will not be required on projects consisting solely of mobile operation work, such as striping or milling edgeline rumble strips. The BEGIN ROAD WORK NEXT X MILES, CONTRACTOR and END ROAD WORK signs shall be erected at or near the CSJ limits.
- Except for devices required by Note 10, traffic control devices should be in place only while work is actually in progress or a definite need exists.
- The Engineer has the final decision on the location of all traffic control devices.
- Inactive equipment and work vehicles, including workers' private vehicles must be parked away from travel lanes. They should be as close to the right-of-way line as possible, or located behind a barrier or guardrail, or as approved by the Engineer.

WORKER SAFETY APPAREL NOTES:

- Workers on foot who are exposed to traffic or to construction equipment within the right-of-way shall wear high-visibility safety apparel meeting the requirements of ISEA "American National Standard for High-Visibility Apparel," or equivalent revisions, and labeled as ANSI 107-2004 standard performance for Class 2 or 3 risk exposure. Class 3 garments should be considered for high traffic volume work areas or night time work.

DATE:
 FILE:

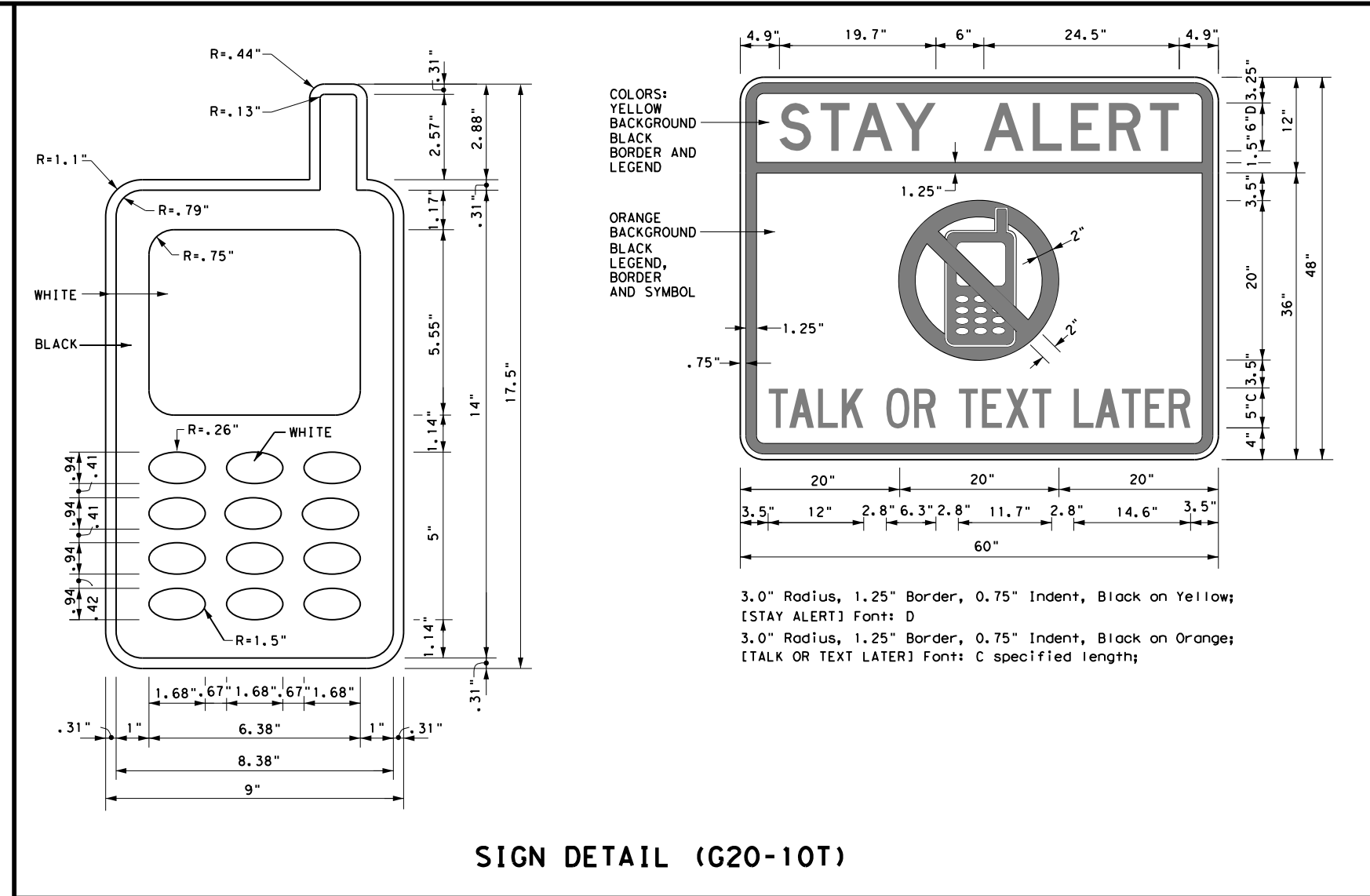

Only pre-qualified products shall be used. The "Compliant Work Zone Traffic Control Devices List" (CWZTCD) describes pre-qualified products and their sources and may be found on-line at the web address given below or by contacting:

Texas Department of Transportation
 Traffic Operations Division - TE
 Phone (512) 416-3118

THE DOCUMENTS BELOW CAN BE FOUND ON-LINE AT http://www.txdot.gov	
COMPLIANT WORK ZONE TRAFFIC CONTROL DEVICES LIST (CWZTCD)	
DEPARTMENTAL MATERIAL SPECIFICATIONS (DMS)	
MATERIAL PRODUCER LIST (MPL)	
ROADWAY DESIGN MANUAL - SEE "MANUALS (ONLINE MANUALS)"	
STANDARD HIGHWAY SIGN DESIGNS FOR TEXAS (SHSD)	
TEXAS MANUAL ON UNIFORM TRAFFIC CONTROL DEVICES (TMUTCD)	
TRAFFIC ENGINEERING STANDARD SHEETS	

SHEET 1 OF 12

		<i>Traffic Operations Division Standard</i>
BARRICADE AND CONSTRUCTION GENERAL NOTES AND REQUIREMENTS		
BC (1) - 14		
FILE: bc-14.dgn	DW: TxDOT	CK: TxDOT
© TxDOT November 2002	CONT: 0083	SECT: 03
REVISIONS		JOB: 056
4-03 5-10 8-14	DIST: COUNTY	SH 154, ETC
9-07 7-13	PAR: HOPKINS, ETC	SHEET NO. 34

DISCLAIMER: The use of this standard is governed by the "Texas Engineering Practice Act". No warranty of any kind is made by TxDOT for any purpose whatsoever. TxDOT assumes no responsibility for incorrect results or damages resulting from its use.

TYPICAL LOCATION OF CROSSROAD SIGNS

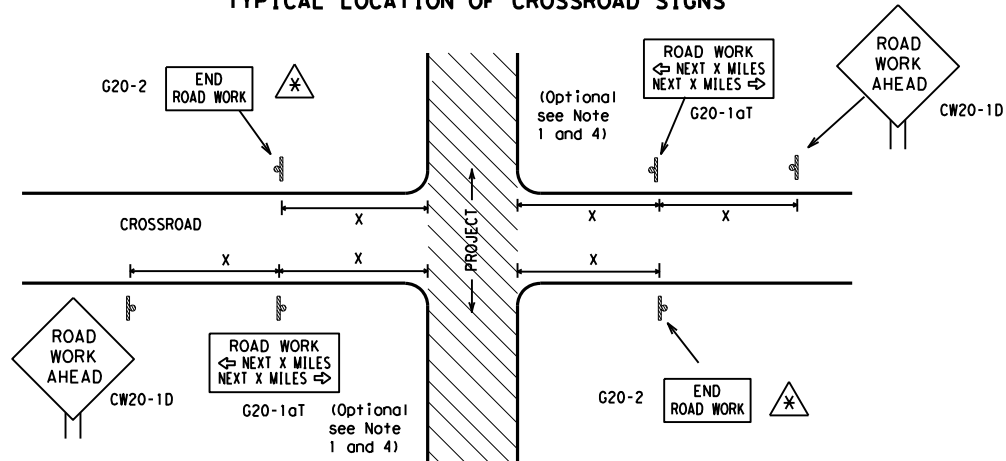

* May be mounted on back of "ROAD WORK AHEAD" (CW20-1D) sign with approval of Engineer. (See note 2 below)

- The typical minimum signing on a crossroad approach should be a "ROAD WORK AHEAD" (CW20-1D) sign and a (G20-2) "END ROAD WORK" sign, unless noted otherwise in plans.
- The Engineer may use the reduced size 36" x 36" ROAD WORK AHEAD (CW20-1D) sign mounted back to back with the reduced size 36" x 18" "END ROAD WORK" (G20-2) sign on low volume crossroads (see Note 4 under "Typical Construction Warning Sign Size and Spacing"). See the "Standard Highway Sign Designs for Texas" manual for sign details. The Engineer may omit the advance warning signs on low volume crossroads. The Engineer will determine whether a road is low volume. This information shall be shown in the plans.
- Based on existing field conditions, the Engineer/Inspector may require additional signs such as FLAGGER AHEAD, LOOSE GRAVEL, or other appropriate signs. When additional signs are required, these signs will be considered part of the minimum requirements. The Engineer/Inspector will determine the proper location and spacing of any sign not shown on the BC sheets, Traffic Control Plan sheets or the Work Zone Standard Sheets.
- The "ROAD WORK NEXT X MILES" (G20-1aT) sign shall be required at high volume crossroads to advise motorists of the length of construction in either direction from the intersection. The Engineer will determine whether a roadway is considered high volume.
- Additional traffic control devices may be shown elsewhere in the plans for higher volume crossroads.
- When work occurs in the intersection area, appropriate traffic control devices, as shown elsewhere in the plans or as determined by the Engineer/Inspector, shall be in place.

T-INTERSECTION

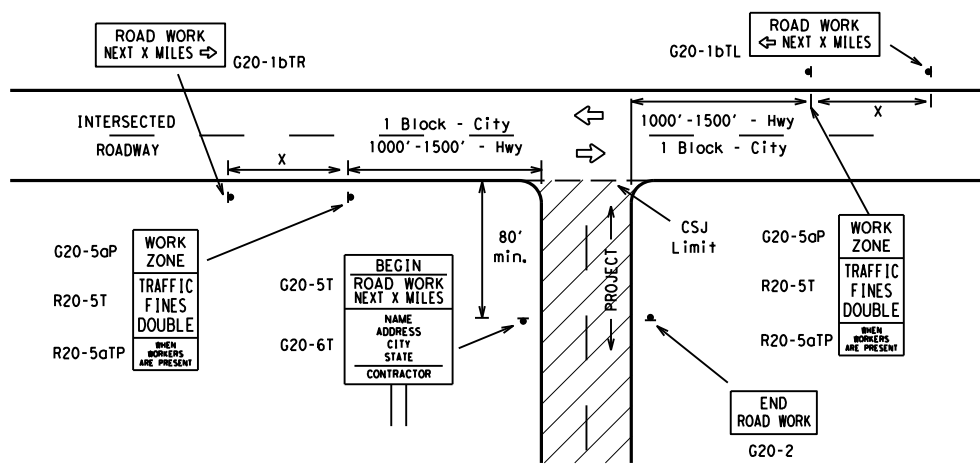

CSJ LIMITS AT T-INTERSECTION

- The Engineer will determine the types and location of any additional traffic control devices, such as a flagger and accompanying signs, or other signs, that should be used when work is being performed at or near an intersection.
- If construction closes the road at a T-intersection the Contractor shall place the "CONTRACTOR NAME" (G20-6T) sign behind the Type 3 Barricades for the road closure (see BC(10) also). The "ROAD WORK NEXT X MILES" left arrow (G20-1bTL) and "ROAD WORK NEXT X MILES" right arrow (G20-1bTR) signs shall be replaced by the detour signing called for in the plans.

TYPICAL CONSTRUCTION WARNING SIGN SIZE AND SPACING^{1,5,6}

Sign Number or Series	SIZE		SPACING	
	Conventional Road	Expressway/Freeway	Posted Speed MPH	Sign Spacing "X" Feet (Approx.)
CW20 ⁴	48" x 48"	48" x 48"	30	120
CW21			35	160
CW22			40	240
CW23			45	320
CW25			50	400
CW1, CW2, CW7, CW8, CW9, CW11, CW14	36" x 36"	48" x 48"	55	500 ²
CW3, CW4, CW5, CW6, CW8-3, CW10, CW12	48" x 48"	48" x 48"	60	600 ²
			65	700 ²
			70	800 ²
			75	900 ²
			80	1000 ²
			*	* ³

* For typical sign spacings on divided highways, expressways and freeways, see Part 6 of the "Texas Manual on Uniform Traffic Control Devices" (TMUTCD) typical application diagrams or TCP Standard Sheets.

Δ Minimum distance from work area to first Advance Warning sign nearest the work area and/or distance between each additional sign.

GENERAL NOTES

- Special or larger size signs may be used as necessary.
- Distance between signs should be increased as required to have 1500 feet advance warning.
- Distance between signs should be increased as required to have 1/2 mile or more advance warning.
- 36" x 36" "ROAD WORK AHEAD" (CW20-1D) signs may be used on low volume crossroads at the discretion of the Engineer. See Note 2 under "Typical Location of Crossroad Signs".
- Only diamond shaped warning sign sizes are indicated.
- See sign size listing in "TMUTCD", Sign Appendix or the "Standard Highway Sign Designs for Texas" manual for complete list of available sign design sizes.

WORK AREAS IN MULTIPLE LOCATIONS WITHIN CSJ LIMITS

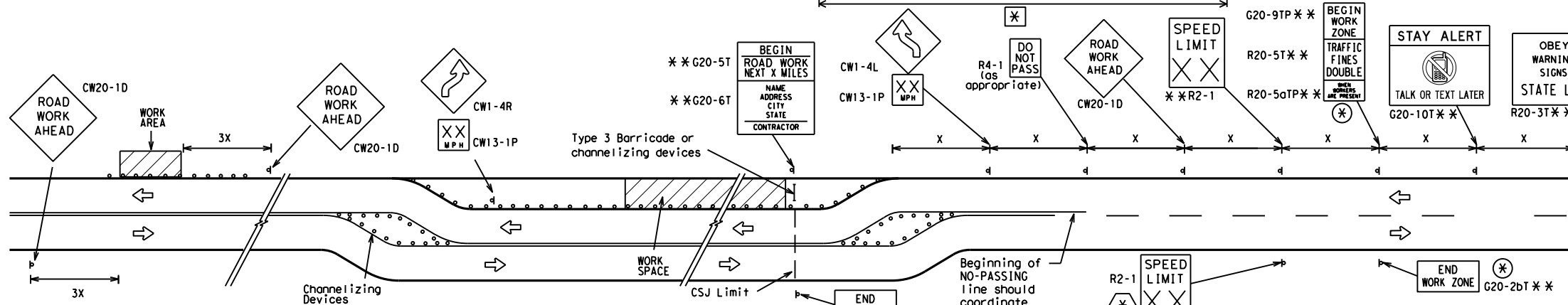

When extended distances occur between minimal work spaces, the Engineer/Inspector should ensure additional "ROAD WORK AHEAD" (CW20-1D) signs are placed in advance of these work areas to remind drivers they are still within the project limits. See the applicable TCP sheets for exact location and spacing of signs and channelizing devices.

SAMPLE LAYOUT OF SIGNING FOR WORK BEGINNING DOWNSTREAM OF THE CSJ LIMITS

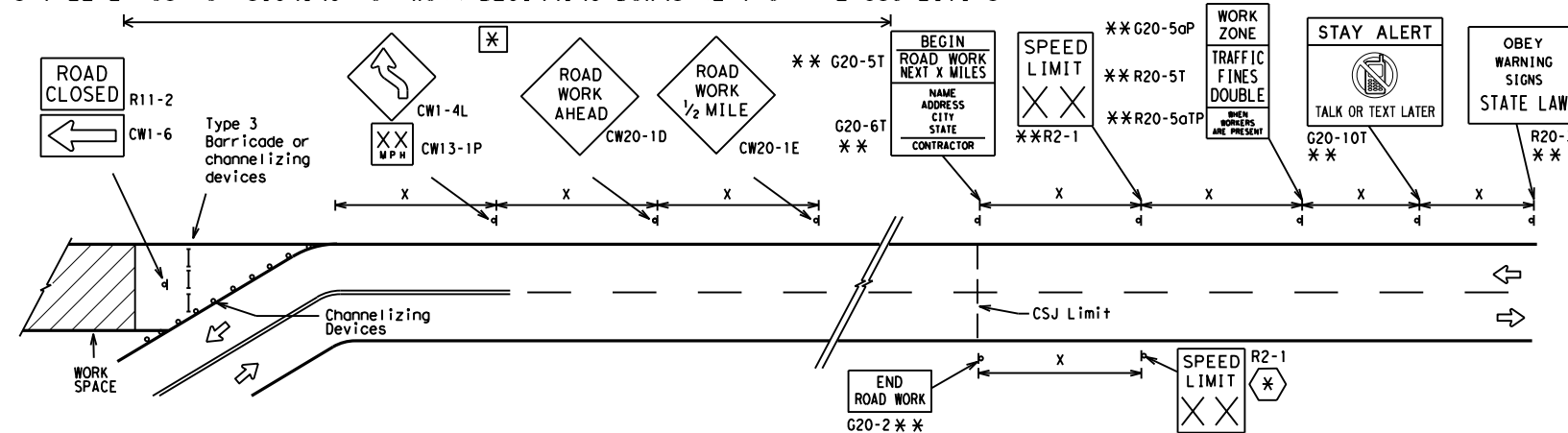

SAMPLE LAYOUT OF SIGNING FOR WORK BEGINNING AT THE CSJ LIMITS

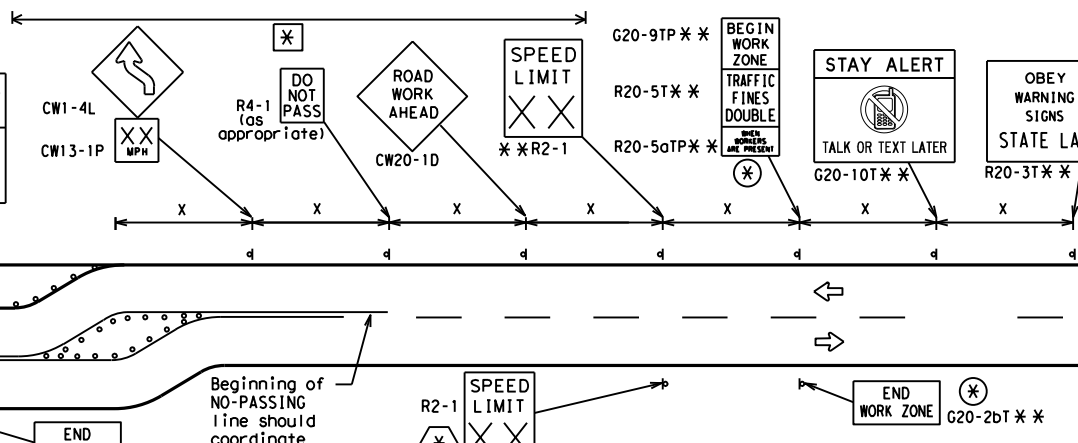

NOTES

The Contractor shall determine the appropriate distance to be placed on the G20-1 series signs and "BEGIN ROAD WORK NEXT X MILES" (G20-5T) sign for each specific project. This distance shall replace the "X" and shall be rounded to the nearest whole mile with the approval of the Engineer. No decimals shall be used.

* The "BEGIN WORK ZONE" (G20-9TP) and "END WORK ZONE" (G20-2bT) shall be used as shown on the sample layout when advance signs are required outside the CSJ Limits. They inform the motorist of entering or leaving a part of the work zone lying outside the CSJ Limits where traffic fines may double if workers are present.

** Required CSJ Limit signing. See Note 10 on BC(1). TRAFFIC FINES DOUBLE signs will not be required on projects consisting solely of mobile operations work.

* Area for placement of "ROAD WORK AHEAD" (CW20-1D) sign and other signs or devices as called for on the Traffic Control Plan.

* Contractor will install a regulatory speed limit sign at the end of the work zone.

LEGEND

—	Type 3 Barricade
○ ○ ○	Channelizing Devices
—	Sign
X	See Typical Construction Warning Sign Size and Spacing chart or the TMUTCD for sign spacing requirements.

SHEET 2 OF 12



BARRICADE AND CONSTRUCTION PROJECT LIMIT

BC(2)-14

FILE: bc-14.dgn	DN: TxDOT	CR: TxDOT	OW: TxDOT	CK: TxDOT
© TxDOT November 2002	CONT	SECT	JOB	HIGHWAY
REVISIONS	0083	03	056	SH 154, ETC
9-07 8-14	DIST	COUNTY	SHEET NO.	
7-13	PAR	HOPKINS, ETC	35	

DATE: FILE:

TYPICAL APPLICATION OF WORK ZONE SPEED LIMIT SIGNS

Work zone speed limits shall be regulatory, established in accordance with the "Procedures for Establishing Speed Zones," and approved by the Texas Transportation Commission, or by City Ordinance when within Incorporated City Limits.

Reduced speeds should only be posted in the vicinity of work activity and not throughout the entire project. Regulatory work zone speed signs (R2-1) shall be removed or covered during periods when they are not needed.



GUIDANCE FOR USE:

LONG/INTERMEDIATE TERM WORK ZONE SPEED LIMITS

This type of work zone speed limit should be included on the design of the traffic control plans when restricted geometrics with a lower design speed are present in the work zone and modification of the geometrics to a higher design speed is not feasible.

Long/Intermediate Term Work Zone Speed Limit signs, when approved as described above, should be posted and visible to the motorist when work activity is present. Work activity may also be defined as a change in the roadway that requires a reduced speed for motorists to safely negotiate the work area, including:

- rough road or damaged pavement surface
- substantial alteration of roadway geometrics (diversions)
- construction detours
- grade
- width
- other conditions readily apparent to the driver

As long as any of these conditions exist, the work zone speed limit signs should remain in place.

SHORT TERM WORK ZONE SPEED LIMITS

This type of work zone speed limit may be included on the design of the traffic control plans when workers or equipment are not behind concrete barrier, when work activity is within 10 feet of the traveled way or actually in the traveled way.

Short Term Work Zone Speed Limit signs should be posted and visible to the motorists only when work activity is present. When work activity is not present, signs shall be removed or covered. (See Removing or Covering on BC(4)).

GENERAL NOTES

- Regulatory work zone speed limits should be used only for sections of construction projects where speed control is of major importance.
- Regulatory work zone speed limit signs shall be placed on supports at a 7 foot minimum mounting height.
- Speed zone signs are illustrated for one direction of travel and are normally posted for each direction of travel.
- Frequency of work zone speed limit signs should be:

40 mph and greater	0.2 to 2 miles
35 mph and less	0.2 to 1 mile
- Regulatory speed limit signs shall have black legend and border on a white reflective background (See "Reflective Sheeting" on BC(4)).
- Fabrication, erection and maintenance of the "ADVANCE SPEED LIMIT" (CW3-5) sign, "WORK ZONE" (G20-5aP) plaque and the "SPEED LIMIT" (R2-1) signs shall not be paid for directly, but shall be considered subsidiary to Item 502.
- Turning signs from view, laying signs over or down will not be allowed, unless as otherwise noted under "REMOVING OR COVERING" on BC(4).
- Techniques that may help reduce traffic speeds include but are not limited to:
 - Law enforcement.
 - Flagger stationed next to sign.
 - Portable changeable message sign (PCMS).
 - Low-power (drone) radar transmitter.
 - Speed monitor trailers or signs.
- Speeds shown on details above are for illustration only. Work Zone Speed Limits should only be posted as approved for each project.
- For more specific guidance concerning the type of work, work zone conditions and factors impacting allowable regulatory construction speed zone reduction see TxDOT form #1204 in the TxDOT e-form system.

DISCLAIMER: The use of this standard is governed by the "Texas Engineering Practice Act". No warranty of any kind is made by TxDOT for any purpose whatsoever. TxDOT assumes no responsibility for the conversion of this standard to other formats or for incorrect results or damages resulting from its use.

DATE:
FILE:

SHEET 3 OF 12



BARRICADE AND CONSTRUCTION WORK ZONE SPEED LIMIT

BC (3) - 14

FILE:	bc-14.dgn	DN: TxDOT	CK: TxDOT	DW: TxDOT	CK: TxDOT
© TxDOT	November 2002	CONT	SECT	JOB	HIGHWAY
REVISIONS		0083	03	056	SH 154, ETC
9-07	8-14	DIST	COUNTY	SHEET NO.	
7-13		PAR	HOPKINS, ETC	36	

TYPICAL MINIMUM CLEARANCES FOR LONG TERM AND INTERMEDIATE TERM SIGNS

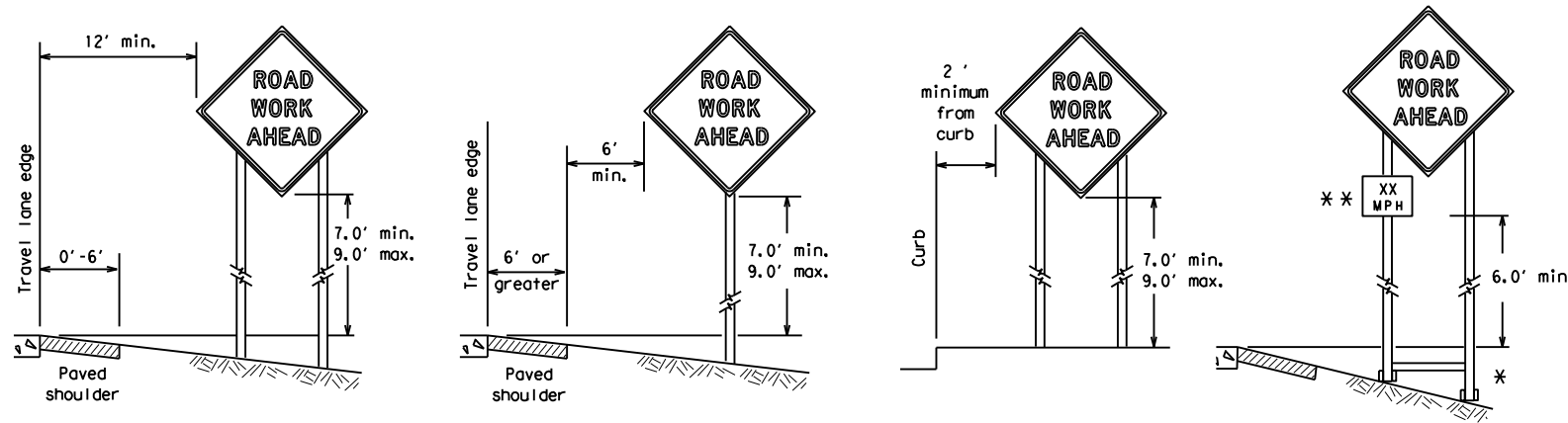

* When placing skid supports on unlevel ground, the leg post lengths must be adjusted so the sign appears straight and plumb. Objects shall NOT be placed under skids as a means of leveling.

** When plaques are placed on dual-leg supports, they should be attached to the upright nearest the travel lane. Supplemental plaques (advisory or distance) should not cover the surface of the parent sign.

ATTACHMENT FOR SIGN SUPPORTS

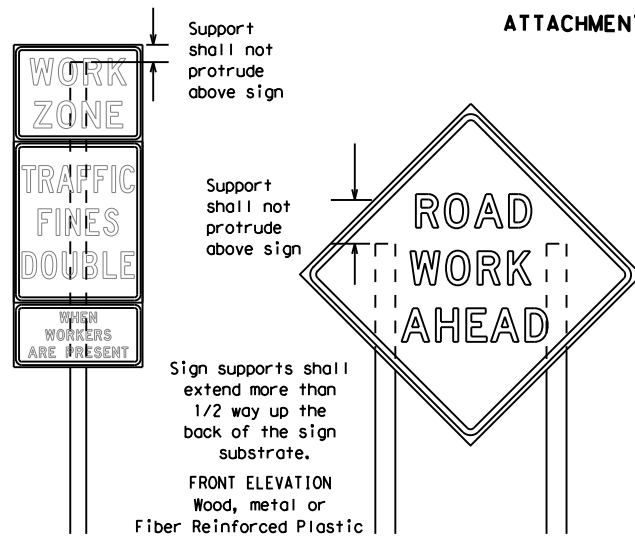

Attachment to wooden supports will be by bolts and nuts or screws. Use TxDOT's or manufacturer's recommended procedures for attaching sign substrates to other types of sign supports

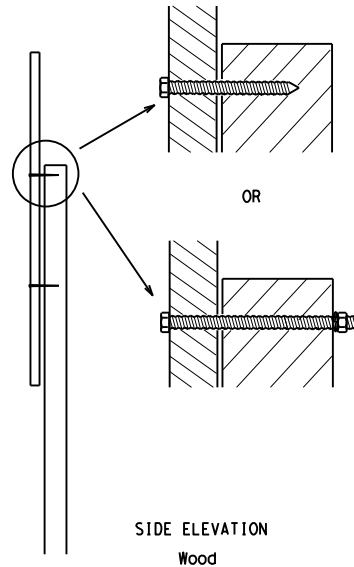

Nails shall NOT be allowed. Each sign shall be attached directly to the sign support. Multiple signs shall not be joined or spliced by any means. Wood supports shall not be extended or repaired by splicing or other means.

Splicing embedded perforated square metal tubing in order to extend post height will only be allowed when the splice is made using four bolts, two above and two below the splice point. Splice must be located entirely behind the sign substrate, not near the base of the support. Splice insert lengths should be at least 5 times nominal post size, centered on the splice and of at least the same gauge material.

STOP/SLOW PADDLES

1. STOP/SLOW paddles are the primary method to control traffic by flaggers. The STOP/SLOW paddle size should be 24" x 24" as detailed below.
2. When used at night, the STOP/SLOW paddle shall be retroreflectORIZED.
3. STOP/SLOW paddles may be attached to a staff with a minimum length of 6' to the bottom of the sign.
4. Any lights incorporated into the STOP or SLOW paddle faces shall only be as specifically described in Section 6E.03 Hand Signaling Devices in the TMUTCD.

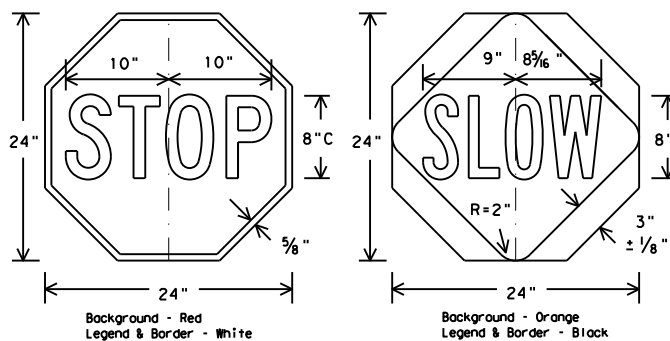

CONTRACTOR REQUIREMENTS FOR MAINTAINING PERMANENT SIGNS WITHIN THE PROJECT LIMITS

1. Permanent signs are used to give notice of traffic laws or regulations, call attention to conditions that are potentially hazardous to traffic operations, show route designations, destinations, directions, distances, services, points of interest, and other geographical, recreational, or cultural information. Drivers proceeding through a work zone need the same, if not better route guidance as normally installed on a roadway without construction.
2. When permanent regulatory or warning signs conflict with work zone conditions, remove or cover the permanent signs until the permanent sign message matches the roadway condition.
3. When existing permanent signs are moved and relocated due to construction purposes, they shall be visible to motorists at all times.
4. If existing signs are to be relocated on their original supports, they shall be installed on crashworthy bases as shown on the SMD Standard sheets. The signs shall meet the required mounting heights shown on the BC Sheets or the SMD Standards. This work should be paid for under the appropriate pay item for relocating existing signs.
5. If permanent signs are to be removed and relocated using temporary supports, the Contractor shall use crashworthy supports as shown on the BC sheets or the CWZTCD. The signs shall meet the required mounting heights shown on the BC Sheets or the SMD Standards during construction. This work should be paid for under the appropriate pay item for relocating existing signs.
6. Any sign or traffic control device that is struck or damaged by the Contractor or his/her construction equipment shall be replaced as soon as possible by the Contractor to ensure proper guidance for the motorists. This will be subsidiary to Item 502.

GENERAL NOTES FOR WORK ZONE SIGNS

1. Contractor shall install and maintain signs in a straight and plumb condition and/or as directed by the Engineer.
 2. Wooden sign posts shall be painted white.
 3. Barricades shall NOT be used as sign supports.
 4. All signs shall be installed in accordance with the plans or as directed by the Engineer. Signs shall be used to regulate, warn, and guide the traveling public safely through the work zone.
 5. The Contractor may furnish either the sign design shown in the plans or in the "Standard Highway Sign Designs for Texas" (SHSD). The Engineer/Inspector may require the Contractor to furnish other work zone signs that are shown in the TMUTCD but may have been omitted from the plans. Any variation in the plans shall be documented by written agreement between the Engineer and the Contractor's Responsible Person. All changes must be documented in writing before being implemented. This can include documenting the changes in the Inspector's TxDOT diary and having both the Inspector and Contractor initial and date the agreed upon changes.
 6. The Contractor shall furnish sign supports listed in the "Compliant Work Zone Traffic Control Device List" (CWZTCD). The Contractor shall install the sign support in accordance with the manufacturer's recommendations. If there is a question regarding installation procedures, the Contractor shall furnish the Engineer a copy of the manufacturer's installation recommendations so the Engineer can verify the correct procedures are being followed.
 7. The Contractor is responsible for installing signs on approved supports and replacing signs with damaged or cracked substrates and/or damaged or marred reflective sheeting as directed by the Engineer/Inspector.
 8. Identification markings may be shown only on the back of the sign substrate. The maximum height of letters and/or company logos used for identification shall be 1 inch.
 9. The Contractor shall replace damaged wood posts. New or damaged wood sign posts shall not be spliced.
- DURATION OF WORK (as defined by the "Texas Manual on Uniform Traffic Control Devices" Part 6)**
1. The types of sign supports, sign mounting height, the size of signs, and the type of sign substrates can vary based on the type of work being performed. The Engineer is responsible for selecting the appropriate size sign for the type of work being performed. The Contractor is responsible for ensuring the sign support, sign mounting height and substrate meets manufacturer's recommendations in regard to crashworthiness and duration of work requirements.
 - a. Long-term stationary - work that occupies a location more than 3 days.
 - b. Intermediate-term stationary - work that occupies a location more than one daylight period up to 3 days, or nighttime work lasting more than one hour.
 - c. Short-term stationary - daytime work that occupies a location for more than 1 hour in a single daylight period.
 - d. Short, duration - work that occupies a location up to 1 hour.
 - e. Mobile - work that moves continuously or intermittently (stopping for up to approximately 15 minutes.)

SIGN MOUNTING HEIGHT

1. The bottom of Long-term/Intermediate-term signs shall be at least 7 feet, but not more than 9 feet, above the paved surface, except as shown for supplemental plaques mounted below other signs.
2. The bottom of Short-term/Short Duration signs shall be a minimum of 1 foot above the pavement surface but no more than 2 feet above the ground.
3. Long-term/Intermediate-term Signs may be used in lieu of Short-term/Short Duration signing.
4. Short-term/Short Duration signs shall be used only during daylight and shall be removed at the end of the workday or raised to appropriate Long-term/Intermediate sign height.
5. Regulatory signs shall be mounted at least 7 feet, but not more than 9 feet, above the paved surface regardless of work duration.

SIZE OF SIGNS

1. The Contractor shall furnish the sign sizes shown on BC (2) unless otherwise shown in the plans or as directed by the Engineer.

SIGN SUBSTRATES

1. The Contractor shall ensure the sign substrate is installed in accordance with the manufacturer's recommendations for the type of sign support that is being used. The CWZTCD lists each substrate that can be used on the different types and models of sign supports.
2. "Mesh" type materials are NOT an approved sign substrate, regardless of the tightness of the weave.
3. All wooden individual sign panels fabricated from 2 or more pieces shall have one or more plywood cleat, 1/2" thick by 6" wide, fastened to the back of the sign and extending fully across the sign. The cleat shall be attached to the back of the sign using wood screws that do not penetrate the face of the sign panel. The screws shall be placed on both sides of the splice and spaced at 6" centers. The Engineer may approve other methods of splicing the sign face.

REFLECTIVE SHEETING

1. All signs shall be retroreflective and constructed of sheeting meeting the color and retro-reflectivity requirements of DMS-8300 for rigid signs or DMS-8310 for roll-up signs. The web address for DMS specifications is shown on BC(1).
2. White sheeting, meeting the requirements of DMS-8300 Type A, shall be used for signs with a white background.
3. Orange sheeting, meeting the requirements of DMS-8300 Type B_{FL} or Type C_{FL}, shall be used for rigid signs with orange backgrounds.

SIGN LETTERS

1. All sign letters and numbers shall be clear, and open rounded type uppercase alphabet letters as approved by the Federal Highway Administration (FHWA) and as published in the "Standard Highway Sign Design for Texas" manual. Signs, letters and numbers shall be of first class workmanship in accordance with Department Standards and Specifications.

REMOVING OR COVERING

1. When sign messages may be confusing or do not apply, the signs shall be removed or completely covered.
2. Long-term stationary or intermediate stationary signs installed on square metal tubing may be turned away from traffic 90 degrees when the sign message is not applicable. This technique may not be used for signs installed in the median of divided highways or near any intersections where the sign may be seen from approaching traffic.
3. Signs installed on wooden skids shall not be turned at 90 degree angles to the roadway. These signs should be removed or completely covered when not required.
4. When signs are covered, the material used shall be opaque, such as heavy mil black plastic, or other materials which will cover the entire sign face and maintain their opaque properties under automobile headlights at night, without damaging the sign sheeting.
5. Burlap shall NOT be used to cover signs.
6. Duct tape or other adhesive material shall NOT be affixed to a sign face.
7. Signs and anchor stubs shall be removed and holes backfilled upon completion of work.

SIGN SUPPORT WEIGHTS

1. Where sign supports require the use of weights to keep from turning over, the use of sandbags with dry, cohesionless sand should be used.
2. The sandbags will be tied shut to keep the sand from spilling and to maintain a constant weight.
3. Rock, concrete, iron, steel or other solid objects shall not be permitted for use as sign support weights.
4. Sandbags should weigh a minimum of 35 lbs and a maximum of 50 lbs.
5. Sandbags shall be made of a durable material that tears upon vehicular impact. Rubber (such as tire inner tubes) shall NOT be used.
6. Rubber ballasts designed for channelizing devices should not be used for ballast on portable sign supports. Sign supports designed and manufactured with rubber bases may be used when shown on the CWZTCD list.
7. Sandbags shall only be placed along or laid over the base supports of the traffic control device and shall not be suspended above ground level or hung with rope, wire, chains or other fasteners. Sandbags shall be placed along the length of the skids to weigh down the sign support.
8. Sandbags shall NOT be placed under the skid and shall not be used to level sign supports placed on slopes.

FLAGS ON SIGNS

1. Flags may be used to draw attention to warning signs. When used the flag shall be 16 inches square or larger and shall be orange or fluorescent red-orange in color. Flags shall not be allowed to cover any portion of the sign face.

SHEET 4 OF 12



BARRICADE AND CONSTRUCTION TEMPORARY SIGN NOTES

BC (4) - 14

FILE:	bc-14.dgn	DN:	TxDOT	CR:	TxDOT	OW:	TxDOT	CK:	TxDOT
© TxDOT	November 2002	CONT	SECT	JOB	HIGHWAY				
REVISIONS		0083	03	056	SH 154, ETC				
9-07	8-14	DIST	COUNTY		SHEET NO.				
7-13		PAR	HOPKINS, ETC		37				

DISCLAIMER: The use of this standard is governed by the "Texas Engineering Practice Act". No warranty of any kind is made by TxDOT for any purpose whatsoever. TxDOT assumes no responsibility for the conversion of this standard to other formats or for incorrect results or damages resulting from its use.

DATE:
FILE:

DISCLAIMER: The use of this standard is governed by the "Texas Engineering Practice Act". No warranty of any kind is made by TxDOT for any purpose whatsoever. TxDOT assumes no responsibility for the conversion of this standard to other formats or for incorrect results or damages resulting from its use.

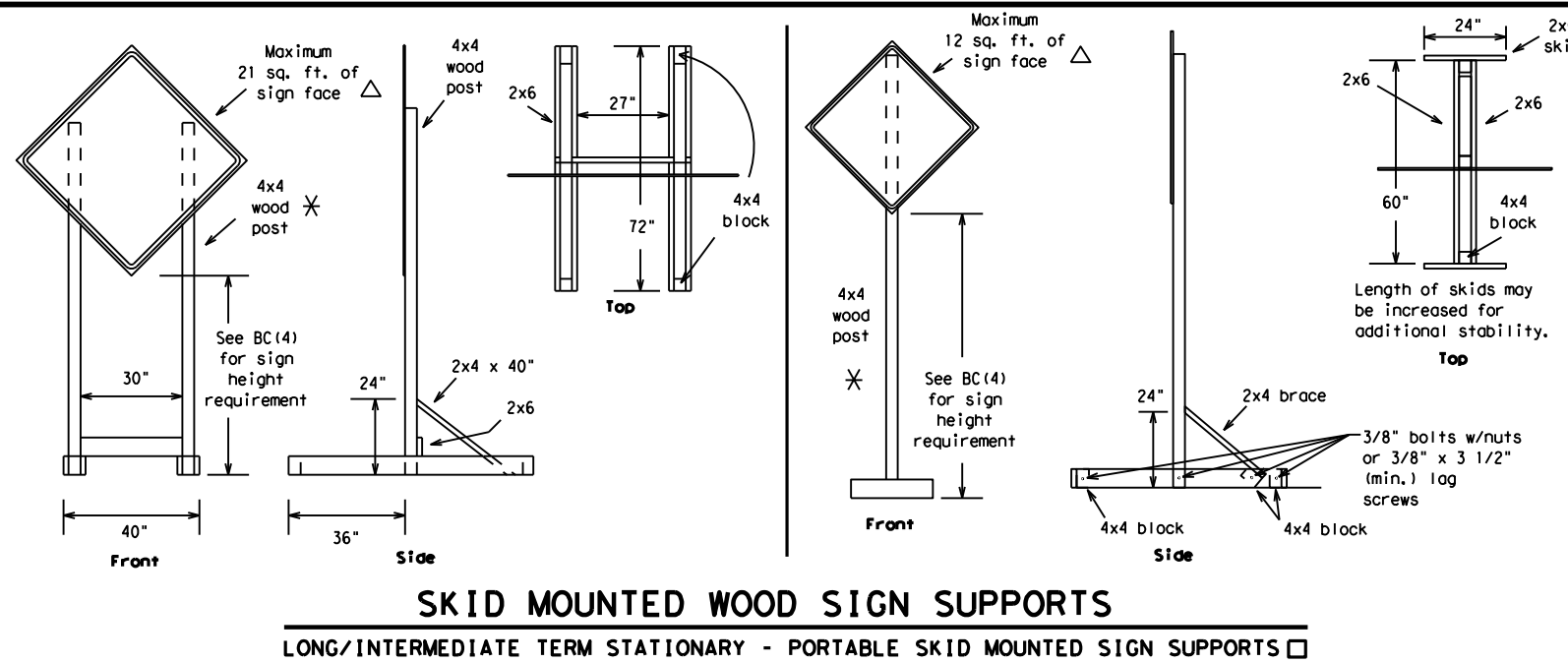

SKID MOUNTED WOOD SIGN SUPPORTS

LONG/INTERMEDIATE TERM STATIONARY - PORTABLE SKID MOUNTED SIGN SUPPORTS □

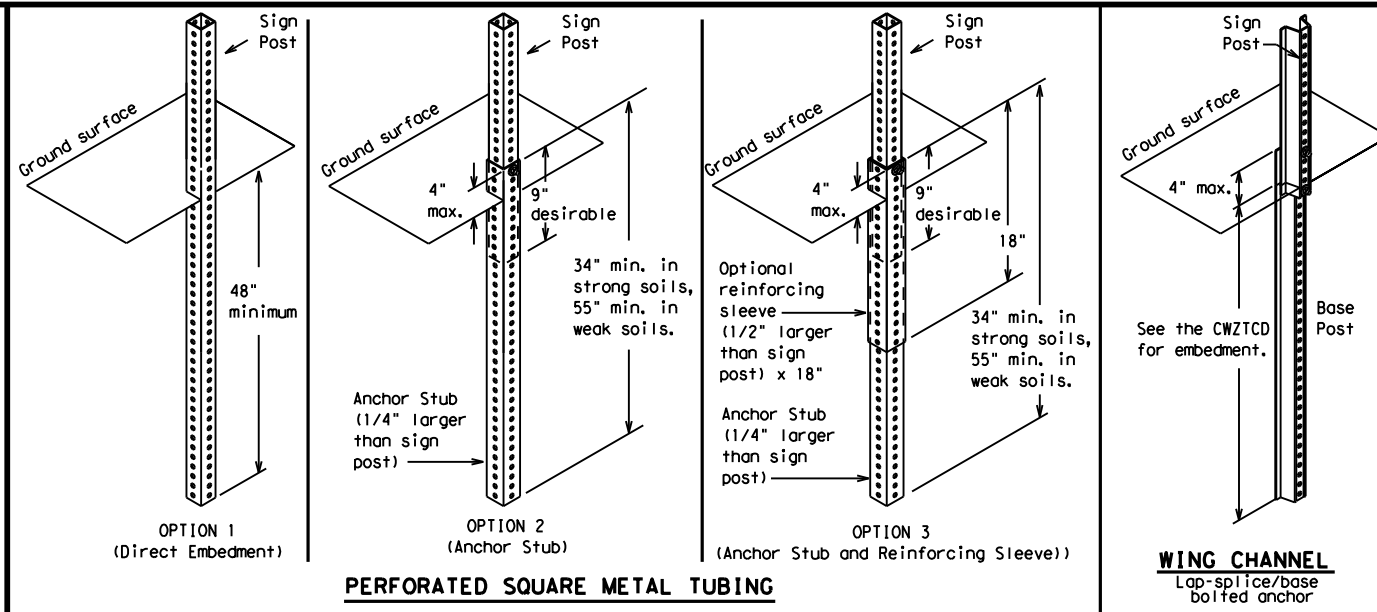

GROUND MOUNTED SIGN SUPPORTS

Refer to the CWZTCD and the manufacturer's installation procedure for each type sign support. The maximum sign square footage shall adhere to the manufacturer's recommendation. Two post installations can be used for larger signs.

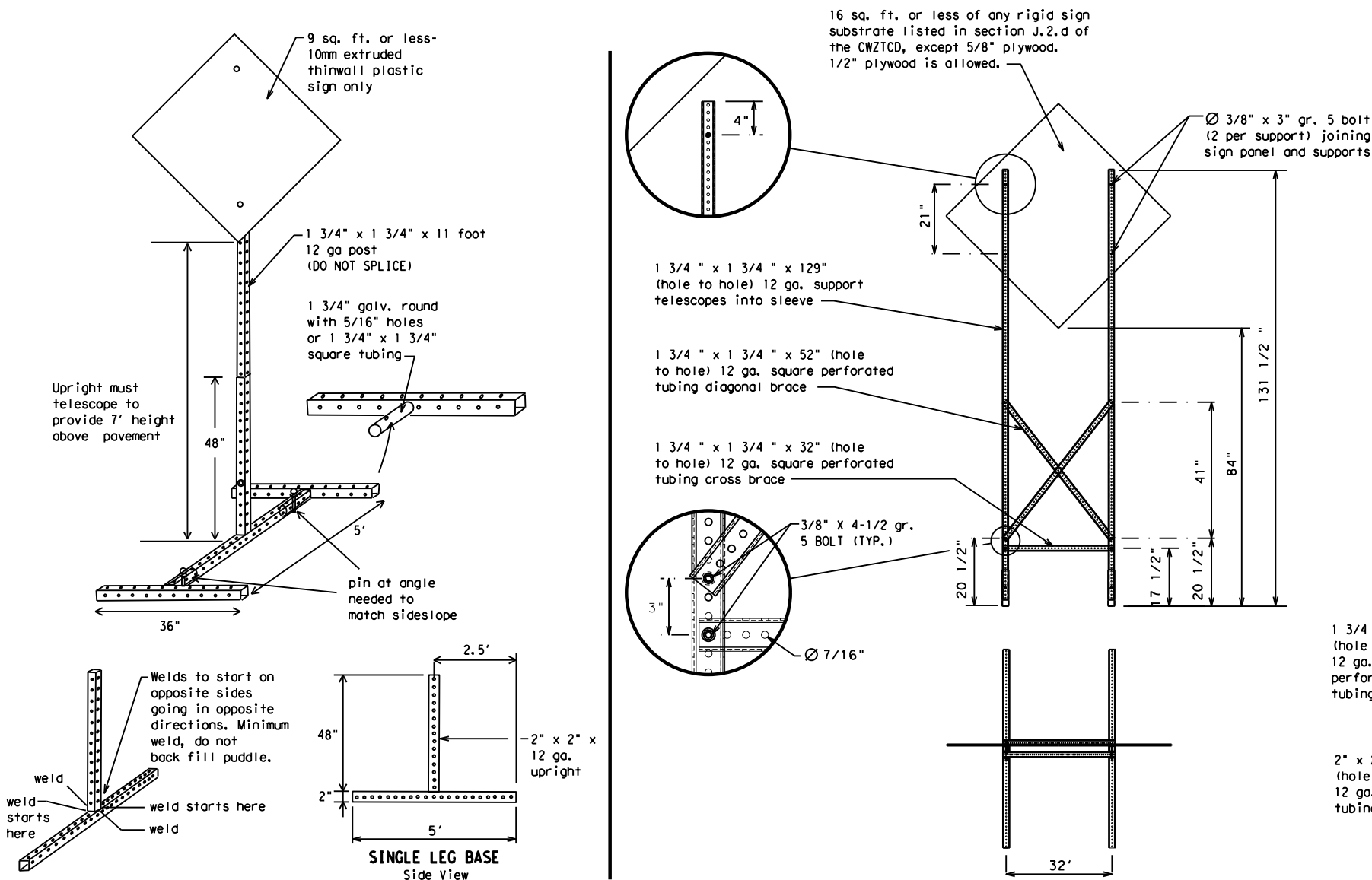

SKID MOUNTED PERFORATED SQUARE STEEL TUBING SIGN SUPPORTS

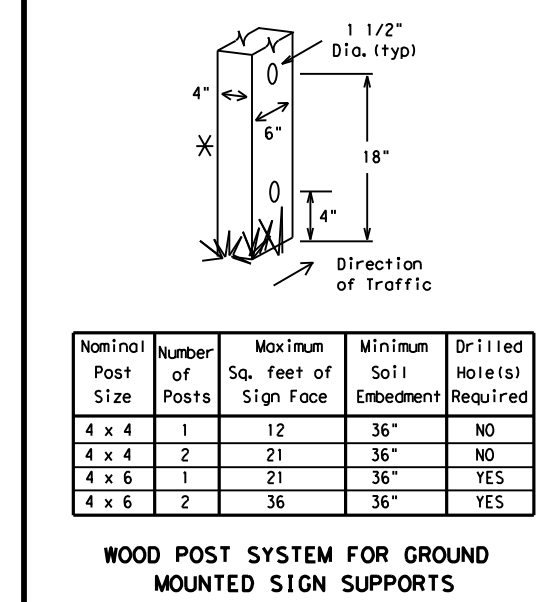

WOOD POST SYSTEM FOR GROUND MOUNTED SIGN SUPPORTS

WEDGE ANCHORS
Both steel and plastic Wedge Anchor Systems as shown on the SMD Standard Sheets may be used as temporary sign supports for signs up to 10 square feet of sign face. They may be set in concrete or in sturdy soils if approved by the Engineer. (See web address for "Traffic Engineering Standard Sheets" on BC(1)).

OTHER DESIGNS
MORE DETAILS OF APPROVED LONG/INTERMEDIATE AND SHORT TERM SUPPORTS CAN BE FOUND ON THE CWZTCD LIST. SEE BC(1) FOR WEBSITE LOCATION.

- GENERAL NOTES**
- Nails may be used in the assembly of wooden sign supports, but 3/8" bolts with nuts or 3/8" x 3 1/2" lag screws must be used on every joint for final connection.
 - No more than 2 sign posts shall be placed within a 7 ft. circle, except for specific materials noted on the CWZTCD List.
 - When project is completed, all sign supports and foundations shall be removed from the project site. This will be considered subsidiary to Item 502.

- See BC(4) for definition of "Work Duration."
- * Wood sign posts MUST be one piece. Splicing will NOT be allowed. Posts shall be painted white.
- △ See the CWZTCD for the type of sign substrate that can be used for each approved sign support.

SHEET 5 OF 12



BARRICADE AND CONSTRUCTION TYPICAL SIGN SUPPORT

BC(5) - 14

FILE: bc-14.dgn	DN: TxDOT	CK: TxDOT	DW: TxDOT	CR: TxDOT
© TxDOT November 2002	CONT	SECT	JOB	HIGHWAY
REVISIONS	0083	03	056	SH 154, ETC
9-07 8-14	DIST	COUNTY	SHEET NO.	
7-13	PAR	HOPKINS, ETC		38

DATE: FILE:

WHEN NOT IN USE, REMOVE THE PCMS FROM THE RIGHT-OF-WAY OR PLACE THE PCMS BEHIND BARRIER OR GUARDRAIL WITH SIGN PANEL TURNED PARALLEL TO TRAFFIC

RECOMMENDED PHASES AND FORMATS FOR PCMS MESSAGES DURING ROADWORK ACTIVITIES

(The Engineer may approve other messages not specifically covered here.)

PORTABLE CHANGEABLE MESSAGE SIGNS

- The Engineer/Inspector shall approve all messages used on portable changeable message signs (PCMS).
- Messages on PCMS should contain no more than 8 words (about four to eight characters per word), not including simple words such as "TO," "FOR," "AT," etc.
- Messages should consist of a single phase, or two phases that alternate. Three-phase messages are not allowed. Each phase of the message should convey a single thought, and must be understood by itself.
- Use the word "EXIT" to refer to an exit ramp on a freeway; i.e., "EXIT CLOSED." Do not use the term "RAMP."
- Always use the route or interstate designation (IH, US, SH, FM) along with the number when referring to a roadway.
- When in use the bottom of a stationary PCMS message panel should be a minimum 7 feet above the roadway, where possible.
- The message term "WEEKEND" should be used only if the work is to start on Saturday morning and end by Sunday evening at midnight. Actual days and hours of work should be displayed on the PCMS if work is to begin on Friday evening and/or continue into Monday morning.
- The Engineer/Inspector may select one of two options which are available for displaying a two-phase message on a PCMS. Each phase may be displayed for either four seconds each or for three seconds each.
- Do not "flash" messages or words included in a message. The message should be steady burn or continuous while displayed.
- Do not present redundant information on a two-phase message; i.e., keeping two lines of the message the same and changing the third line.
- Do not use the word "Danger" in message.
- Do not display the message "LANES SHIFT LEFT" or "LANES SHIFT RIGHT" on a PCMS. Drivers do not understand the message.
- Do not display messages that scroll horizontally or vertically across the face of the sign.
- The following table lists abbreviated words and two-word phrases that are acceptable for use on a PCMS. Both words in a phrase must be displayed together. Words or phrases not on this list should not be abbreviated, unless shown in the TMUTCD.
- PCMS character height should be at least 18 inches for trailer mounted units. They should be visible from at least 1/2 (.5) mile and the text should be legible from at least 600 feet at night and 800 feet in daylight. Truck mounted units must have a character height of 10 inches and must be legible from at least 400 feet.
- Each line of text should be centered on the message board rather than left or right justified.
- If disabled, the PCMS should default to an illegible display that will not alarm motorists and will only be used to alert workers that the PCMS has malfunctioned. A pattern such as a series of horizontal solid bars is appropriate.

Phase 1: Condition Lists

Road/Lane/Ramp Closure List

FREEWAY CLOSED X MILE
ROAD CLOSED AT SH XXX
ROAD CLSD AT FM XXXX
RIGHT X LANES CLOSED
CENTER LANE CLOSED
NIGHT LANE CLOSURES
VARIOUS LANES CLOSED
EXIT CLOSED
MALL DRIVEWAY CLOSED
XXXXXXXX BLVD CLOSED

Other Condition List

FRONTAGE ROAD CLOSED
SHOULDER CLOSED XXX FT
RIGHT LN CLOSED XXX FT
RIGHT X LANES OPEN
DAYTIME LANE CLOSURES
I-XX SOUTH EXIT CLOSED
EXIT XXX CLOSED X MILE
RIGHT LN TO BE CLOSED
X LANES CLOSED TUE - FRI

ROADWORK XXX FT
FLAGGER XXXX FT
RIGHT LN NARROWS XXXX FT
MERGING TRAFFIC XXXX FT
LOOSE GRAVEL XXXX FT
DETOUR X MILE
ROADWORK PAST SH XXXX
BUMP XXXX FT
TRAFFIC SIGNAL XXXX FT

ROAD REPAIRS XXXX FT
LANE NARROWS XXXX FT
TWO-WAY TRAFFIC XX MILE
CONST TRAFFIC XXX FT
UNEVEN LANES XXXX FT
ROUGH ROAD XXXX FT
ROADWORK NEXT FRI-SUN
US XXX EXIT X MILES
LANES SHIFT *

* LANES SHIFT in Phase 1 must be used with STAY IN LANE in Phase 2.

Phase 2: Possible Component Lists

Action to Take/Effect on Travel List

MERGE RIGHT
DETOUR NEXT X EXITS
USE EXIT XXX
STAY ON US XXX SOUTH
TRUCKS USE US XXX N
WATCH FOR TRUCKS
EXPECT DELAYS
REDUCE SPEED XXX FT
USE OTHER ROUTES
STAY IN LANE *

FORM X LINES RIGHT
USE XXXXX RD EXIT
USE EXIT I-XX NORTH
USE I-XX E TO I-XX N
WATCH FOR TRUCKS
EXPECT DELAYS
PREPARE TO STOP
END SHOULDER USE
WATCH FOR WORKERS

Location List

AT FM XXXX
BEFORE RAILROAD CROSSING
NEXT X MILES
PAST US XXX EXIT
XXXXXXXX TO XXXXXX
US XXX TO FM XXXX

Warning List

SPEED LIMIT XX MPH
MAXIMUM SPEED XX MPH
MINIMUM SPEED XX MPH
ADVISORY SPEED XX MPH
RIGHT LANE EXIT
USE CAUTION
DRIVE SAFELY
DRIVE WITH CARE

** Advance Notice List

TUE-FRI XX AM-X PM
APR XX-XX X PM-X AM
BEGINS MONDAY
BEGINS MAY XX
MAY X-X XX PM - XX AM
NEXT FRI-SUN
XX AM TO XX PM
NEXT TUE AUG XX
TONIGHT XX PM-XX AM

** See Application Guidelines Note 6.

APPLICATION GUIDELINES

- Only 1 or 2 phases are to be used on a PCMS.
- The 1st phase (or both) should be selected from the "Road/Lane/Ramp Closure List" and the "Other Condition List".
- A 2nd phase can be selected from the "Action to Take/Effect on Travel, Location, General Warning, or Advance Notice Phase Lists".
- A Location Phase is necessary only if a distance or location is not included in the first phase selected.
- If two PCMS are used in sequence, they must be separated by a minimum of 1000 ft. Each PCMS shall be limited to two phases, and should be understandable by themselves.
- For advance notice, when the current date is within seven days of the actual work date, calendar days should be replaced with days of the week. Advance notification should typically be for no more than one week prior to the work.

WORDING ALTERNATIVES

- The words RIGHT, LEFT and ALL can be interchanged as appropriate.
- Roadway designations IH, US, SH, FM and LP can be interchanged as appropriate.
- EAST, WEST, NORTH and SOUTH (or abbreviations E, W, N and S) can be interchanged as appropriate.
- Highway names and numbers replaced as appropriate.
- ROAD, HIGHWAY and FREEWAY can be interchanged as needed.
- AHEAD may be used instead of distances if necessary.
- FT and MI, MILE and MILES interchanged as appropriate.
- AT, BEFORE and PAST interchanged as needed.
- Distances or AHEAD can be eliminated from the message if a location phase is used.

PCMS SIGNS WITHIN THE R.O.W. SHALL BE BEHIND GUARDRAIL OR CONCRETE BARRIER OR SHALL HAVE A MINIMUM OF FOUR (4) PLASTIC DRUMS PLACED PERPENDICULAR TO TRAFFIC ON THE UPSTREAM SIDE OF THE PCMS, WHEN EXPOSED TO ONE DIRECTION OF TRAFFIC. WHEN EXPOSED TO TWO WAY TRAFFIC, THE FOUR DRUMS SHOULD BE PLACED WITH ONE DRUM AT EACH OF THE FOUR CORNERS OF THE UNIT.

FULL MATRIX PCMS SIGNS

- When Full Matrix PCMS signs are used, the character height and legibility/visibility requirements shall be maintained as listed in Note 15 under "PORTABLE CHANGEABLE MESSAGE SIGNS" above.
- When symbol signs, such as the "Flagger Symbol" (CW20-7) are represented graphically on the Full Matrix PCMS sign and, with the approval of the Engineer, it shall maintain the legibility/visibility requirement listed above.
- When symbol signs are represented graphically on the Full Matrix PCMS, they shall only supplement the use of the static sign represented, and shall not substitute for, or replace that sign.
- A full matrix PCMS may be used to simulate a flashing arrow board provided it meets the visibility, flash rate and dimming requirements on BC(7), for the same size arrow.

DISCLAIMER: The use of this standard is governed by the "Texas Engineering Practice Act". No warranty of any kind is made by TxDOT for any purpose whatsoever. TxDOT assumes no responsibility for the conversion of this standard to other formats or for incorrect results or damages resulting from its use.

DATE: FILE:

WORD OR PHRASE	ABBREVIATION	WORD OR PHRASE	ABBREVIATION
Access Road	ACCS RD	Major	MAJ
Alternate	ALT	Miles	MI
Avenue	AVE	Miles Per Hour	MPH
Best Route	BEST RTE	Minor	MNR
Boulevard	BLVD	Monday	MON
Bridge	BRDG	Normal	NORM
Canal	CANT	North	N
Center	CTR	Northbound	(route) N
Construction Ahead	CONST AHD	Parking	PKING
CROSSING	XING	Road	RD
Detour Route	DETOUR RTE	Right Lane	RT LN
Do Not	DONT	Saturday	SAT
East	E	Service Road	SERV RD
Eastbound	(route) E	Shoulder	SHLDR
Emergency	EMER	Slippery	SLIP
Emergency Vehicle	EMER VEH	South	S
Entrance, Enter	ENT	Southbound	(route) S
Express Lane	EXP LN	Speed	SPD
Expressway	EXPWY	Street	ST
XXXX Feet	XXXX FT	Sunday	SUN
Fog Ahead	FOG AHD	Telephone	PHONE
Freeway	FRWY, FWY	Temporary	TEMP
Freeway Blocked	FWY BLKD	Thursday	THURS
Friday	FRI	To Downtown	TO DWNTN
Hazardous Driving	HAZ DRIVING	Traffic	TRAF
Hazardous Material	HAZMAT	Travelers	TRVLR
High-Occupancy Vehicle	HOV	Tuesday	TUES
Highway	HWY	Time Minutes	TIME MIN
Hour(s)	HR, HRS	Upper Level	UPR LEVEL
Information	INFO	Vehicles (s)	VEH, VEHS
It Is	ITS	Warning	WARN
Junction	JCT	Wednesday	WED
Left	LFT	Weight Limit	WT LIMIT
Left Lane	LFT LN	West	W
Lane Closed	LN CLOSED	Westbound	(route) W
Lower Level	LWR LEVEL	Wet Pavement	WET PVMT
Maintenance	MAINT	Will Not	WONT

Roadway designation # IH-number, US-number, SH-number, FM-number

SHEET 6 OF 12

<h2>BARRICADE AND CONSTRUCTION PORTABLE CHANGEABLE MESSAGE SIGN (PCMS)</h2>			
<h3>BC (6) - 14</h3>			
FILE: bc-14.dgn	DN: TxDOT	CR: TxDOT	DW: TxDOT
© TxDOT November 2002	CONT: 0083	SECT: 03	JOB: SH 154, ETC
REVISIONS: 9-07 8-14	DIST: PAR	COUNTY: HOPKINS, ETC	SHEET NO.: 39

DISCLAIMER: The use of this standard is governed by the "Texas Engineering Practice Act". No warranty of any kind is made by TxDOT for any purpose whatsoever. TxDOT assumes no responsibility for the conversion of this standard to other formats or for incorrect results or damages resulting from its use.

- Barrier Reflectors shall be pre-qualified, and conform to the color and reflectivity requirements of DMS-8600. A list of prequalified Barrier Reflectors can be found at the Material Producer List web address shown on BC(1).
- Color of Barrier Reflectors shall be as specified in the TMUTCD. The cost of the reflectors shall be considered subsidiary to Item 512.

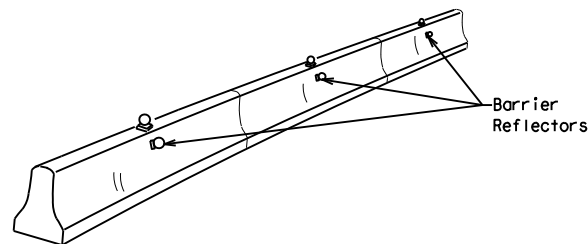

CONCRETE TRAFFIC BARRIER (CTB)

- Where traffic is on one side of the CTB, two (2) Barrier Reflectors shall be mounted in approximately the midsection of each section of CTB. An alternate mounting location is uniformly spaced at one end of each CTB. This will allow for attachment of a barrier grapple without damaging the reflector. The Barrier Reflector mounted on the side of the CTB shall be located directly below the reflector mounted on top of the barrier, as shown in the detail above.
- Where CTB separates two-way traffic, three barrier reflectors shall be mounted on each section of CTB. The reflector unit on top shall have two yellow reflective faces (Bi-Directional) while the reflectors on each side of the barrier shall have one yellow reflective face, as shown in the detail above.
- When CTB separates traffic traveling in the same direction, no barrier reflectors will be required on top of the CTB.
- Barrier Reflector units shall be yellow or white in color to match the edgeline being supplemented.
- Maximum spacing of Barrier Reflectors is forty (40) feet.
- Pavement markers or temporary flexible-reflective roadway marker tabs shall NOT be used as CTB delineation.
- Attachment of Barrier Reflectors to CTB shall be per manufacturer's recommendations.
- Missing or damaged Barrier Reflectors shall be replaced as directed by the Engineer.
- Single slope barriers shall be delineated as shown on the above detail.

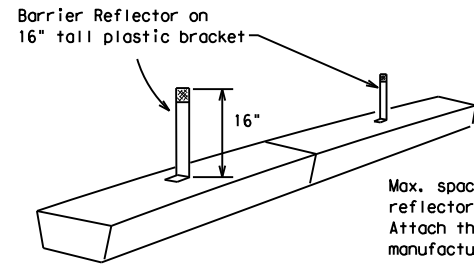

LOW PROFILE CONCRETE BARRIER (LPCB)

Max. spacing of barrier reflectors is 20 feet. Attach the delineators as per manufacturer's recommendations.

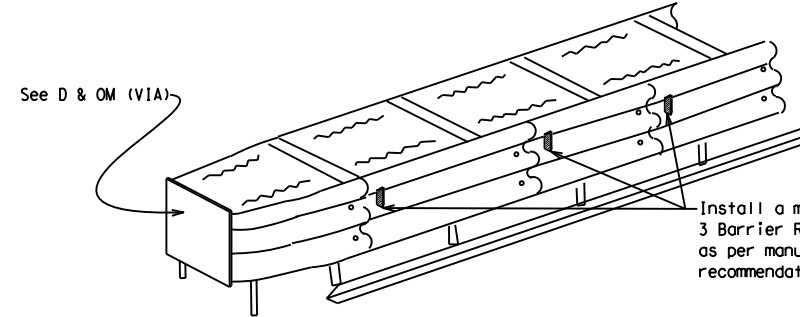

DELINEATION OF END TREATMENTS

END TREATMENTS FOR CTB'S USED IN WORK ZONES
 End treatments used on CTB's in work zones shall meet crashworthy standards as defined in the National Cooperative Highway Research Report 350. Refer to the CWZTCD List for approved end treatments and manufacturers.

BARRIER REFLECTORS FOR CONCRETE TRAFFIC BARRIER AND ATTENUATORS

WARNING LIGHTS

- Warning lights shall meet the requirements of the TMUTCD.
- Warning lights shall NOT be installed on barricades.
- Type A-Low Intensity Flashing Warning Lights are commonly used with drums. They are intended to warn of or mark a potentially hazardous area. Their use shall be as indicated on this sheet and/or other sheets of the plans by the designation "FL". The Type A Warning Lights shall not be used with signs manufactured with Type B_{FL} or C_{FL} Sheeting meeting the requirements of Departmental Material Specification DMS-8300.
- Type-C and Type D 360 degree Steady Burn Lights are intended to be used in a series for delineation to supplement other traffic control devices. Their use shall be as indicated on this sheet and/or other sheets of the plans by the designation "SB".
- The Engineer/Inspector or the plans shall specify the location and type of warning lights to be installed on the traffic control devices.
- When required by the Engineer, the Contractor shall furnish a copy of the warning lights certification. The warning light manufacturer will certify the warning lights meet the requirements of the latest ITE Purchase Specifications for Flashing and Steady-Burn Warning Lights.
- When used to delineate curves, Type-C and Type D Steady Burn Lights should only be placed on the outside of the curve, not the inside.
- The location of warning lights and warning reflectors on drums shall be as shown elsewhere in the plans.

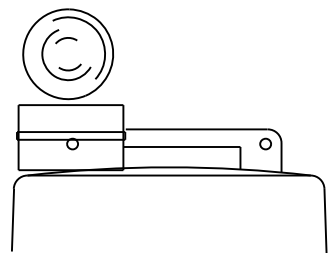

Type C Warning Light or approved substitute mounted on a drum adjacent to the travel way.

WARNING LIGHTS MOUNTED ON PLASTIC DRUMS

- Type A flashing warning lights are intended to warn drivers that they are approaching or are in a potentially hazardous area.
- Type A random flashing warning lights are not intended for delineation and shall not be used in a series.
- A series of sequential flashing warning lights placed on channelizing devices to form a merging taper may be used for delineation. If used, the successive flashing of the sequential warning lights should occur from the beginning of the taper to the end of the merging taper in order to identify the desired vehicle path. The rate of flashing for each light shall be 65 flashes per minute, plus or minus 10 flashes.
- Type C and D steady-burn warning lights are intended to be used in a series to delineate the edge of the travel lane on detours, on lane changes, and on lane closures, and on other similar conditions.
- Type A, Type C and Type D warning lights shall be installed at locations as detailed on other sheets in the plans.
- Warning lights shall not be installed on a drum that has a sign, chevron or vertical panel.
- The maximum spacing for warning lights on drums should be identical to the channelizing device spacing.

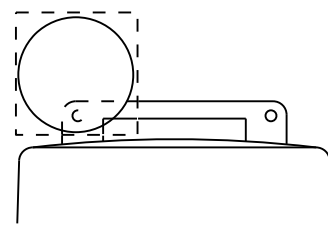

Warning reflector may be round or square. Must have a yellow reflective surface area of at least 30 square inches

WARNING REFLECTORS MOUNTED ON PLASTIC DRUMS AS A SUBSTITUTE FOR TYPE C (STEADY BURN) WARNING LIGHTS

- A warning reflector or approved substitute may be mounted on a plastic drum as a substitute for a Type C, steady burn warning light at the discretion of the Contractor unless otherwise noted in the plans.
- The warning reflector shall be yellow in color and shall be manufactured using a sign substrate approved for use with plastic drums listed on the CWZTCD.
- The warning reflector shall have a minimum retroreflective surface area (one-side) of 30 square inches.
- Round reflectors shall be fully reflectorized, including the area where attached to the drum.
- Square substrates must have a minimum of 30 square inches of reflectorized sheeting. They do not have to be reflectorized where it attaches to the drum.
- The side of the warning reflector facing approaching traffic shall have sheeting meeting the color and retroreflectivity requirements for DMS 8300-Type B or Type C.
- When used near two-way traffic, both sides of the warning reflector shall be reflectorized.
- The warning reflector should be mounted on the side of the handle nearest approaching traffic.
- The maximum spacing for warning reflectors should be identical to the channelizing device spacing requirements.

Arrow Boards may be located behind channelizing devices in place for a shoulder taper or merging taper, otherwise they shall be delineated with four (4) channelizing devices placed perpendicular to traffic on the upstream side of traffic.

- The Flashing Arrow Board should be used for all lane closures on multi-lane roadways, or slow moving maintenance or construction activities on the travel lanes.
- Flashing Arrow Boards should not be used on two-lane, two-way roadways, detours, diversions or work on shoulders unless the "CAUTION" display (see detail below) is used.
- The Engineer/Inspector shall choose all appropriate signs, barricades and/or other traffic control devices that should be used in conjunction with the Flashing Arrow Board.
- The Flashing Arrow Board should be able to display the following symbols:

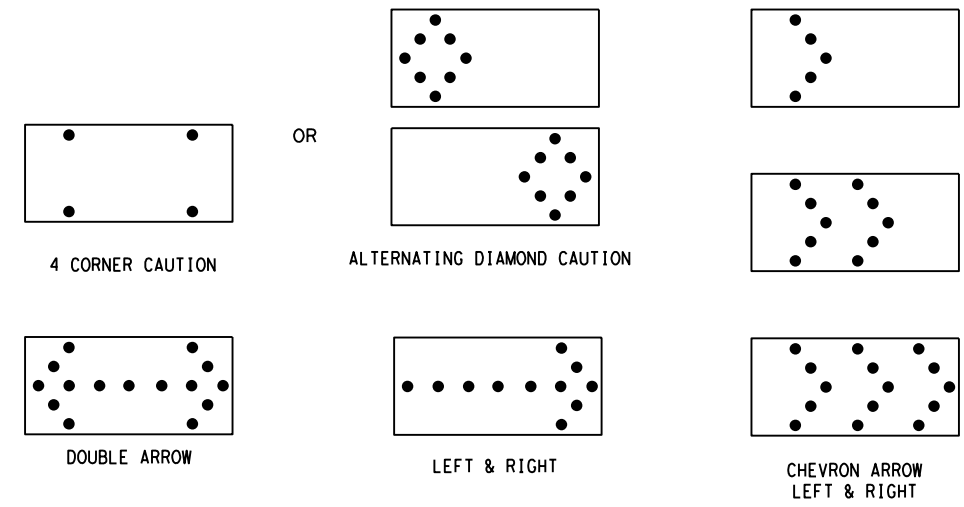

- The "CAUTION" display consists of four corner lamps flashing simultaneously, or the Alternating Diamond Caution mode as shown.
- The straight line caution display is NOT ALLOWED.
- The Flashing Arrow Board shall be capable of minimum 50 percent dimming from rated lamp voltage. The flashing rate of the lamps shall not be less than 25 nor more than 40 flashes per minute.
- Minimum lamp "on time" shall be approximately 50 percent for the flashing arrow and equal intervals of 25 percent for each sequential phase of the flashing chevron.
- The sequential arrow display is NOT ALLOWED.
- The flashing arrow display is the TxDOT standard; however, the sequential Chevron display may be used during daylight operations.
- The Flashing Arrow Board shall be mounted on a vehicle, trailer or other suitable support.
- A Flashing Arrow Board SHALL NOT BE USED to laterally shift traffic.
- A full matrix PCMS may be used to simulate a Flashing Arrow Board provided it meets visibility, flash rate and dimming requirements on this sheet for the same size arrow.
- Minimum mounting height of trailer mounted Arrow Boards should be 7 feet from roadway to bottom of panel.

REQUIREMENTS			
TYPE	MINIMUM SIZE	MINIMUM NUMBER OF PANEL LAMPS	MINIMUM VISIBILITY DISTANCE
B	30 x 60	13	3/4 mile
C	48 x 96	15	1 mile

ATTENTION
 Flashing Arrow Boards shall be equipped with automatic dimming devices.

WHEN NOT IN USE, REMOVE THE ARROW BOARD FROM THE RIGHT-OF-WAY OR PLACE THE ARROW BOARD BEHIND CONCRETE TRAFFIC BARRIER OR GUARDRAIL.

FLASHING ARROW BOARDS

SHEET 7 OF 12

TRUCK-MOUNTED ATTENUATORS

- Truck-mounted attenuators (TMA) used on TxDOT facilities must meet the requirements outlined in the National Cooperative Highway Research Report No. 350 (NCHRP 350) or the Manual for Assessing Safety Hardware (MASH).
- Refer to the CWZTCD for the requirements of Level 2 or Level 3 TMAs.
- Refer to the CWZTCD for a list of approved TMAs.
- TMAs are required on freeways unless otherwise noted in the plans.
- A TMA should be used anytime that it can be positioned 30 to 100 feet in advance of the area of crew exposure without adversely affecting the work performance.
- The only reason a TMA should not be required is when a work area is spread down the roadway and the work crew is an extended distance from the TMA.



BARRICADE AND CONSTRUCTION ARROW PANEL, REFLECTORS, WARNING LIGHTS & ATTENUATOR

BC(7)-14

FILE:	bc-14.dgn	DN:	TxDOT	CR:	TxDOT	DW:	TxDOT	CK:	TxDOT
© TxDOT	November 2002	CONT	SECT	JOB	HIGHWAY				
REVISIONS		0083	03	056	SH 154, ETC				
9-07	8-14	DIST	COUNTY		SHEET NO.				
7-13		PAR	HOPKINS, ETC		40				

DATE:
FILE:

DISCLAIMER: The use of this standard is governed by the "Texas Engineering Practice Act". No warranty of any kind is made by TxDOT for any purpose whatsoever. TxDOT assumes no responsibility for the conversion of this standard to other formats or for incorrect results or damages resulting from its use.

GENERAL NOTES

- For long term stationary work zones on freeways, drums shall be used as the primary channelizing device.
- For intermediate term stationary work zones on freeways, drums should be used as the primary channelizing device but may be replaced in tangent sections by vertical panels, or 42" two-piece cones. In tangent sections one-piece cones may be used with the approval of the Engineer but only if personnel are present on the project at all times to maintain the cones in proper position and location.
- For short term stationary work zones on freeways, drums are the preferred channelizing device but may be replaced in tapers, transitions and tangent sections by vertical panels, two-piece cones or one-piece cones as approved by the Engineer.
- Drums and all related items shall comply with the requirements of the current version of the "Texas Manual on Uniform Traffic Control Devices" (TMUTCD) and the "Compliant Work Zone Traffic Control Devices List" (CWZTCD).
- Drums, bases, and related materials shall exhibit good workmanship and shall be free from objectionable marks or defects that would adversely affect their appearance or serviceability.
- The Contractor shall have a maximum of 24 hours to replace any plastic drums identified for replacement by the Engineer/Inspector. The replacement device must be an approved device.

GENERAL DESIGN REQUIREMENTS

Pre-qualified plastic drums shall meet the following requirements:

- Plastic drums shall be a two-piece design; the "body" of the drum shall be the top portion and the "base" shall be the bottom.
- The body and base shall lock together in such a manner that the body separates from the base when impacted by a vehicle traveling at a speed of 20 MPH or greater but prevents accidental separation due to normal handling and/or air turbulence created by passing vehicles.
- Plastic drums shall be constructed of lightweight flexible, and deformable materials. The Contractor shall NOT use metal drums or single piece plastic drums as channelization devices or sign supports.
- Drums shall present a profile that is a minimum of 18 inches in width at the 36 inch height when viewed from any direction. The height of drum unit (body installed on base) shall be a minimum of 36 inches and a maximum of 42 inches.
- The top of the drum shall have a built-in handle for easy pickup and shall be designed to drain water and not collect debris. The handle shall have a minimum of two widely spaced 9/16 inch diameter holes to allow attachment of a warning light, warning reflector unit or approved compliant sign.
- The exterior of the drum body shall have a minimum of four alternating orange and white retroreflective circumferential stripes not less than 4 inches nor greater than 8 inches in width. Any non-reflectORIZED space between any two adjacent stripes shall not exceed 2 inches in width.
- Bases shall have a maximum width of 36 inches, a maximum height of 4 inches, and a minimum of two footholds of sufficient size to allow base to be held down while separating the drum body from the base.
- Plastic drums shall be constructed of ultra-violet stabilized, orange, high-density polyethylene (HDPE) or other approved material.
- Drum body shall have a maximum unballasted weight of 11 lbs.
- Drum and base shall be marked with manufacturer's name and model number.

RETROREFLECTIVE SHEETING

- The stripes used on drums shall be constructed of sheeting meeting the color and retroreflectivity requirements of Departmental Materials Specification DMS-8300, "Sign Face Materials." Type A reflective sheeting shall be supplied unless otherwise specified in the plans.
- The sheeting shall be suitable for use on and shall adhere to the drum surface such that, upon vehicular impact, the sheeting shall remain adhered in-place and exhibit no delaminating, cracking, or loss of retroreflectivity other than that loss due to abrasion of the sheeting surface.

BALLAST

- Unballasted bases shall be large enough to hold up to 50 lbs. of sand. This base, when filled with the ballast material, should weigh between 35 lbs (minimum) and 50 lbs (maximum). The ballast may be sand in one to three sandbags separate from the base, sand in a sand-filled plastic base, or other ballasting devices as approved by the Engineer. Stacking of sandbags will be allowed, however height of sandbags above pavement surface may not exceed 12 inches.
- Bases with built-in ballast shall weigh between 40 lbs. and 50 lbs. Built-in ballast can be constructed of an integral crumb rubber base or a solid rubber base.
- Recycled truck tire sidewalls may be used for ballast on drums approved for this type of ballast on the CWZTCD list.
- The ballast shall not be heavy objects, water, or any material that would become hazardous to motorists, pedestrians, or workers when the drum is struck by a vehicle.
- When used in regions susceptible to freezing, drums shall have drainage holes in the bottoms so that water will not collect and freeze becoming a hazard when struck by a vehicle.
- Ballast shall not be placed on top of drums.
- Adhesives may be used to secure base of drums to pavement.

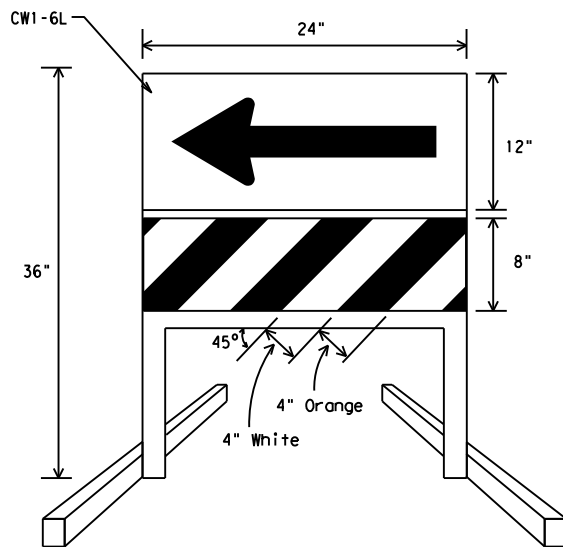
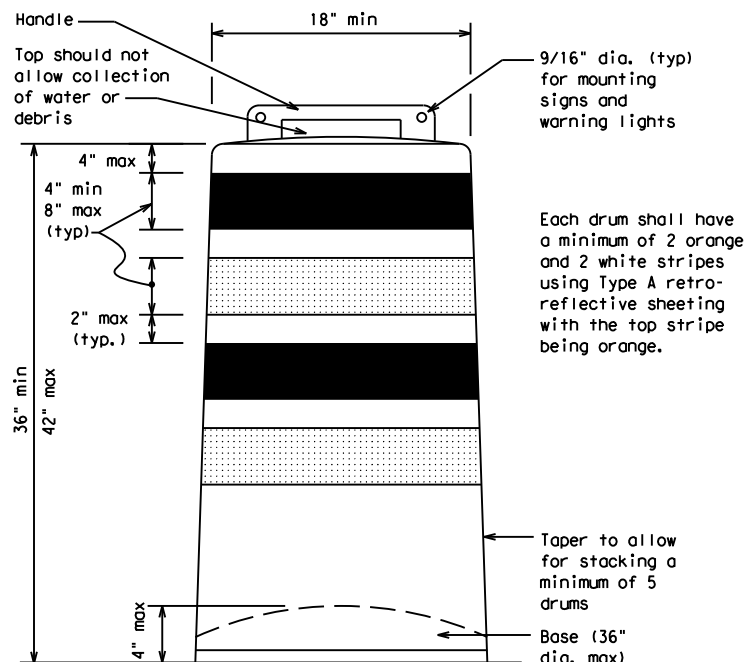

DIRECTION INDICATOR BARRICADE

- The Direction Indicator Barricade may be used in tapers, transitions, and other areas where specific directional guidance to drivers is necessary.
- If used, the Direction Indicator Barricade should be used in series to direct the driver through the transition and into the intended travel lane.
- The Direction Indicator Barricade shall consist of One-Direction Large Arrow (CWI-6) sign in the size shown with a black arrow on a background of Type B_{FL} or Type C_{FL} Orange retroreflective sheeting above a rail with Type A retroreflective sheeting in alternating 4" white and orange stripes sloping downward at an angle of 45 degrees in the direction road users are to pass. Sheetting types shall be as per DMS 8300.
- Double arrows on the Direction Indicator Barricade will not be allowed.
- Approved manufacturers are shown on the CWZTCD List. Ballast shall be as approved by the manufacturers instructions.

DETECTABLE PEDESTRIAN BARRICADES

- When existing pedestrian facilities are disrupted, closed, or relocated in a TTC zone, the temporary facilities shall be detectable and include accessibility features consistent with the features present in the existing pedestrian facility.
- Where pedestrians with visual disabilities normally use the closed sidewalk, a device that is detectable by a person with a visual disability traveling with the aid of a long cane shall be placed across the full width of the closed sidewalk.
- Detectable pedestrian barricades similar to the one pictured above, longitudinal channelizing devices, some concrete barriers, and wood or chain link fencing with a continuous detectable edging can satisfactorily delineate a pedestrian path.
- Tape, rope, or plastic chain strung between devices are not detectable, do not comply with the design standards in the "Americans with Disabilities Act Accessibility Guidelines for Buildings and Facilities (ADAAG)" and should not be used as a control for pedestrian movements.
- Warning lights shall not be attached to detectable pedestrian barricades.
- Detectable pedestrian barricades may use 8" nominal barricade rails as shown on BC(10) provided that the top rail provides a smooth continuous rail suitable for hand trailing with no splinters, burrs, or sharp edges.

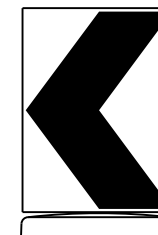

18" x 24" Sign
(Maximum Sign Dimension)
Chevron CWI-8, Opposing Traffic Lane
Divider, Driveway sign D70a, Keep Right
R4 series or other signs as approved
by Engineer

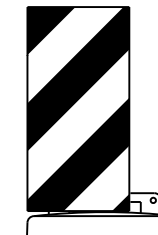

12" x 24"
Vertical Panel
mount with diagonals
sloping down towards
travel way

Plywood, Aluminum or Metal sign
substrates shall NOT be used on
plastic drums

SIGNS, CHEVRONS, AND VERTICAL PANELS MOUNTED ON PLASTIC DRUMS

- Signs used on plastic drums shall be manufactured using substrates listed on the CWZTCD.
- Chevrons and other work zone signs with an orange background shall be manufactured with Type B_{FL} or Type C_{FL} Orange sheeting meeting the color and retroreflectivity requirements of DMS-8300, "Sign Face Material," unless otherwise specified in the plans.
- Vertical Panels shall be manufactured with orange and white sheeting meeting the requirements of DMS-8300 Type A Diagonal stripes on Vertical Panels shall slope down toward the intended traveled lane.
- Other sign messages (text or symbolic) may be used as approved by the Engineer. Sign dimensions shall not exceed 18 inches in width or 24 inches in height, except for the R9 series signs discussed in note 8 below.
- Signs shall be installed using a 1/2 inch bolt (nominal) and nut, two washers, and one locking washer for each connection.
- Mounting bolts and nuts shall be fully engaged and adequately torqued. Bolts should not extend more than 1/2 inch beyond nuts.
- Chevrons may be placed on drums on the outside of curves, on merging tapers or on shifting tapers. When used in these locations they may be placed on every drum or spaced not more than on every third drum. A minimum of three (3) should be used at each location called for in the plans.
- R9-9, R9-10, R9-11 and R9-11a Sidewalk Closed signs which are 24 inches wide may be mounted on plastic drums, with approval of the Engineer.

SHEET 8 OF 12



BARRICADE AND CONSTRUCTION CHANNELIZING DEVICES

BC (8) - 14

FILE: bc-14.dgn	DW: TxDOT	CR: TxDOT	DW: TxDOT	CR: TxDOT
© TxDOT November 2002	CONT	SECT	JOB	HIGHWAY
REVISIONS	0083	03	056	SH 154, ETC
4-03 7-13	DIST	COUNTY	SHEET NO.	
9-07 8-14	PAR	HOPKINS, ETC	41	

DATE: FILE:

DISCLAIMER: The use of this standard is governed by the "Texas Engineering Practice Act". No warranty of any kind is made by TxDOT for any purpose whatsoever. TxDOT assumes no responsibility for the conversion of this standard to other formats or for incorrect results or damages resulting from its use.

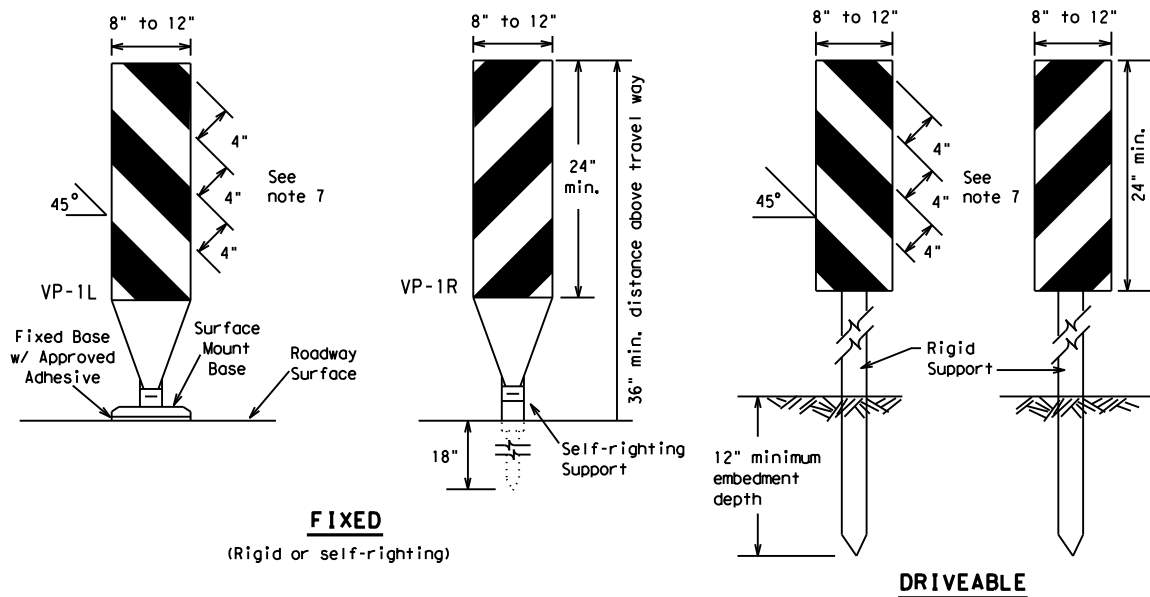

FIXED
(Rigid or self-righting)

DRIVEABLE

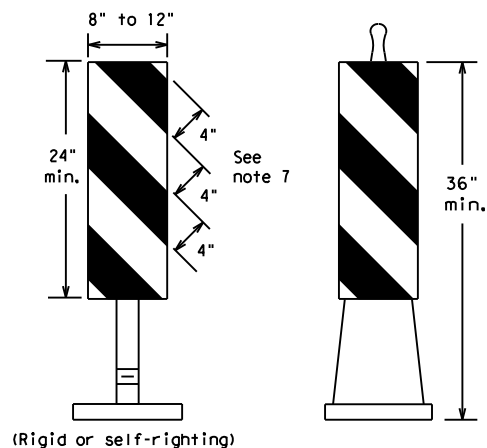

(Rigid or self-righting)

PORTABLE

VERTICAL PANELS (VPs)

- Vertical Panels (VP's) are normally used to channelize traffic or divide opposing lanes of traffic.
- VP's may be used in daytime or nighttime situations. They may be used at the edge of shoulder drop-offs and other areas such as lane transitions where positive daytime and nighttime delineation is required. The Engineer/Inspector shall refer to the Roadway Design Manual Appendix B "Treatment of Pavement Drop-offs in Work Zones" for additional guidelines on the use of VP's for drop-offs.
- VP's should be mounted back to back if used at the edge of cuts adjacent to two-way two lane roadways. Stripes are to be reflective orange and reflective white and should always slope downward toward the travel lane.
- VP's used on expressways and freeways or other high speed roadways, may have more than 270 square inches of retroreflective area facing traffic.
- Self-righting supports are available with portable base. See "Compliant Work Zone Traffic Control Devices List" (CWZTCD).
- Sheeting for the VP's shall be retroreflective Type A conforming to Departmental Material Specification DMS-8300, unless noted otherwise.
- Where the height of reflective material on the vertical panel is 36 inches or greater, a panel stripe of 6 inches shall be used.

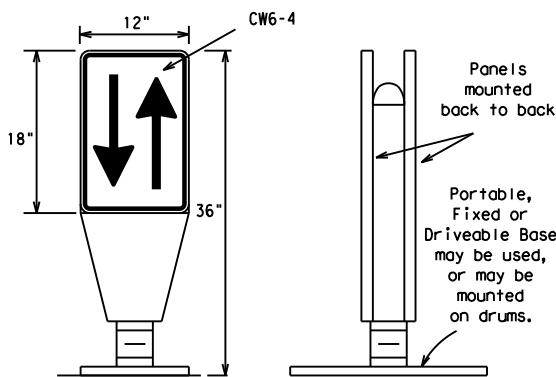

OPPOSING TRAFFIC LANE DIVIDERS (OTLD)

- Opposing Traffic Lane Dividers (OTLD) are delineation devices designed to convert a normal one-way roadway section to two-way operation. OTLD's are used on temporary centerlines. The upward and downward arrows on the sign's face indicate the direction of traffic on either side of the divider. The base is secured to the pavement with an adhesive or rubber weight to minimize movement caused by a vehicle impact or wind gust.
- The OTLD may be used in combination with 42" cones or VPs.
- Spacing between the OTLD shall not exceed 500 feet. 42" cones or VPs placed between the OTLD's should not exceed 100 foot spacing.
- The OTLD shall be orange with a black non-reflective legend. Sheeting for the OTLD shall be retroreflective Type B_{FL} or Type C_{FL} conforming to Departmental Material Specification DMS-8300, unless noted otherwise. The legend shall meet the requirements of DMS-8300.

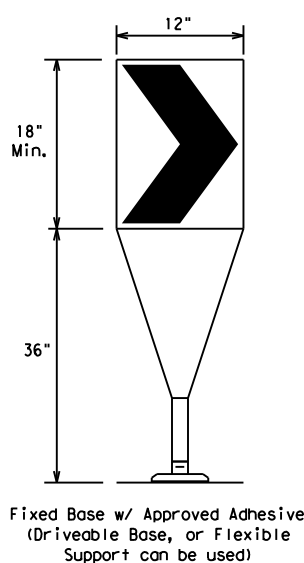

Fixed Base w/ Approved Adhesive (Driveable Base, or Flexible Support can be used)

- The chevron shall be a vertical rectangle with a minimum size of 12 by 18 inches.
- Chevrons are intended to give notice of a sharp change of alignment with the direction of travel and provide additional emphasis and guidance for vehicle operators with regard to changes in horizontal alignment of the roadway.
- Chevrons, when used, shall be erected on the outside of a sharp curve or turn, or on the far side of an intersection. They shall be in line with and at right angles to approaching traffic. Spacing should be such that the motorist always has three in view, until the change in alignment eliminates its need.
- To be effective, the chevron should be visible for at least 500 feet.
- Chevrons shall be orange with a black nonreflective legend. Sheeting for the chevron shall be retroreflective Type B_{FL} or Type C_{FL} conforming to Departmental Material Specification DMS-8300, unless noted otherwise. The legend shall meet the requirements of DMS-8300.
- For Long Term Stationary use on tapers or transitions on freeways and divided highways self-righting chevrons may be used to supplement plastic drums but not to replace plastic drums.

CHEVRONS

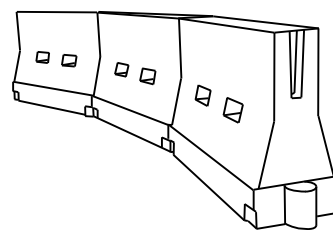

LONGITUDINAL CHANNELIZING DEVICES (LCD)

- LCDs are crashworthy, lightweight, deformable devices that are highly visible, have good target value and can be connected together. They are not designed to contain or redirect a vehicle on impact.
- LCDs may be used instead of a line of cones or drums.
- LCDs shall be placed in accordance to application and installation requirements specific to the device, and used only when shown on the CWZTCD list.
- LCDs should not be used to provide positive protection for obstacles, pedestrians or workers.
- LCDs shall be supplemented with retroreflective delineation as required for temporary barriers on BC(7) when placed roughly parallel to the travel lanes.
- LCDs used as barricades placed perpendicular to traffic should have at least one row of reflective sheeting meeting the requirements for barricade rails as shown on BC(10) placed near the top of the LCD along the full length of the device.

WATER BALLASTED SYSTEMS USED AS BARRIERS

- Water ballasted systems used as barriers shall not be used solely to channelize road users, but also to protect the work space per the appropriate NCHRP 350 crashworthiness requirements based on roadway speed and barrier application.
- Water ballasted systems used to channelize vehicular traffic shall be supplemented with retroreflective delineation or channelizing devices to improve daytime/nighttime visibility. They may also be supplemented with pavement markings.
- Water ballasted systems used as barriers shall be placed in accordance to application and installation requirements specific to the device, and used only when shown on the CWZTCD list.
- Water ballasted systems used as barriers should not be used for a merging taper except in low speed (less than 45 MPH) urban areas. When used on a taper in a low speed urban area, the taper shall be delineated and the taper length should be designed to optimize road user operations considering the available geometric conditions.
- When water ballasted systems used as barriers have blunt ends exposed to traffic, they should be attenuated as per manufacturer recommendations or flared to a point outside the clear zone.

If used to channelize pedestrians, longitudinal channelizing devices or water ballasted systems must have a continuous detectable bottom for users of long canes and the top of the unit shall not be less than 32 inches in height.

HOLLOW OR WATER BALLASTED SYSTEMS USED AS LONGITUDINAL CHANNELIZING DEVICES OR BARRIERS

GENERAL NOTES

- Work Zone channelizing devices illustrated on this sheet may be installed in close proximity to traffic and are suitable for use on high or low speed roadways. The Engineer/Inspector shall ensure that spacing and placement is uniform and in accordance with the "Texas Manual on Uniform Traffic Control Devices" (TMUTCD).
- Channelizing devices shown on this sheet may have a driveable, fixed or portable base. The requirement for self-righting channelizing devices must be specified in the General Notes or other plan sheets.
- Channelizing devices on self-righting supports should be used in work zone areas where channelizing devices are frequently impacted by errant vehicles or vehicle related wind gusts making alignment of the channelizing devices difficult to maintain. Locations of these devices shall be detailed elsewhere in the plans. These devices shall conform to the TMUTCD and the "Compliant Work Zone Traffic Control Devices List" (CWZTCD).
- The Contractor shall maintain devices in a clean condition and replace damaged, nonreflective, faded, or broken devices and bases as required by the Engineer/Inspector. The Contractor shall be required to maintain proper device spacing and alignment.
- Portable bases shall be fabricated from virgin and/or recycled rubber. The portable bases shall weigh a minimum of 30 lbs.
- Pavement surfaces shall be prepared in a manner that ensures proper bonding between the adhesives, the fixed mount bases and the pavement surface. Adhesives shall be prepared and applied according to the manufacturer's recommendations.
- The installation and removal of channelizing devices shall not cause detrimental effects to the final pavement surfaces, including pavement surface discoloration or surface integrity. Driveable bases shall not be permitted on final pavement surfaces. The Engineer/Inspector shall approve all application and removal procedures of fixed bases.

Posted Speed * S	Formula L = WS ² / 60	Minimum Desirable Taper Lengths **			Suggested Maximum Spacing of Channelizing Devices	
		10' Offset	11' Offset	12' Offset	On a Taper	On a Tangent
30	L = WS ² / 60	150'	165'	180'	30'	60'
35		205'	225'	245'	35'	70'
40	L = WS	265'	295'	320'	40'	80'
45		450'	495'	540'	45'	90'
50	L = WS	500'	550'	600'	50'	100'
55		600'	660'	720'	60'	120'
60	L = WS	650'	715'	780'	65'	130'
65		700'	770'	840'	70'	140'
70	L = WS	750'	825'	900'	75'	150'
75		800'	880'	960'	80'	160'
80	L = WS	800'	880'	960'	80'	160'
80		800'	880'	960'	80'	160'

**Taper lengths have been rounded off.
L=Length of Taper (FT.) W=Width of Offset (FT.)
S=Posted Speed (MPH)

SUGGESTED MAXIMUM SPACING OF CHANNELIZING DEVICES AND MINIMUM DESIRABLE TAPER LENGTHS

SHEET 9 OF 12



BARRICADE AND CONSTRUCTION CHANNELIZING DEVICES

BC (9) - 14

FILE: bc-14.dgn	DN: TxDOT	CK: TxDOT	DW: TxDOT	CR: TxDOT
© TxDOT November 2002	CONT	SECT	JOB	HIGHWAY
REVISIONS	0083	03	056	SH 154, ETC
9-07 8-14	DIST	COUNTY	SHEET NO.	
7-13	PAR	HOPKINS, ETC	42	

DATE: FILE:

DISCLAIMER: The use of this standard is governed by the "Texas Engineering Practice Act". No warranty of any kind is made by TxDOT for any purpose whatsoever. TxDOT assumes no responsibility for the conversion of this standard to other formats or for incorrect results or damages resulting from its use.

TYPE 3 BARRICADES

1. Refer to the Compliant Work Zone Traffic Control Devices List (CWZTCD) for details of the Type 3 Barricades and a list of all materials used in the construction of Type 3 Barricades.
2. Type 3 Barricades shall be used at each end of construction projects closed to all traffic.
3. Barricades extending across a roadway should have stripes that slope downward in the direction toward which traffic must turn in detouring. When both right and left turns are provided, the chevron striping may slope downward in both directions from the center of the barricade. Where no turns are provided at a closed road striping should slope downward in both directions toward the center of roadway.
4. Striping of rails, for the right side of the roadway, should slope downward to the left. For the left side of the roadway, striping should slope downward to the right.
5. Identification markings may be shown only on the back of the barricade rails. The maximum height of letters and/or company logos used for identification shall be 1".
6. Barricades shall not be placed parallel to traffic unless an adequate clear zone is provided.
7. Warning lights shall NOT be installed on barricades.
8. Where barricades require the use of weights to keep from turning over, the use of sandbags with dry, cohesionless sand is recommended. The sandbags will be tied shut to keep the sand from spilling and to maintain a constant weight. Sand bags shall not be stacked in a manner that covers any portion of a barricade rails reflective sheeting. Rock, concrete, iron, steel or other solid objects will NOT be permitted. Sandbags should weigh a minimum of 35 lbs and a maximum of 50 lbs. Sandbags shall be made of a durable material that tears upon vehicular impact. Rubber (such as tire inner tubes) shall not be used for sandbags. Sandbags shall only be placed along or upon the base supports of the device and shall not be suspended above ground level or hung with rope, wire, chains or other fasteners.
9. Sheeting for barricades shall be retroreflective Type A conforming to Departmental Material Specification DMS-8300 unless otherwise noted.

Barricades shall NOT be used as a sign support.



TYPICAL STRIPING DETAIL FOR BARRICADE RAIL



Stiffener may be inside or outside of support, but no more than 2 stiffeners shall be allowed on one barricade.

TYPICAL PANEL DETAIL FOR SKID OR POST TYPE BARRICADES

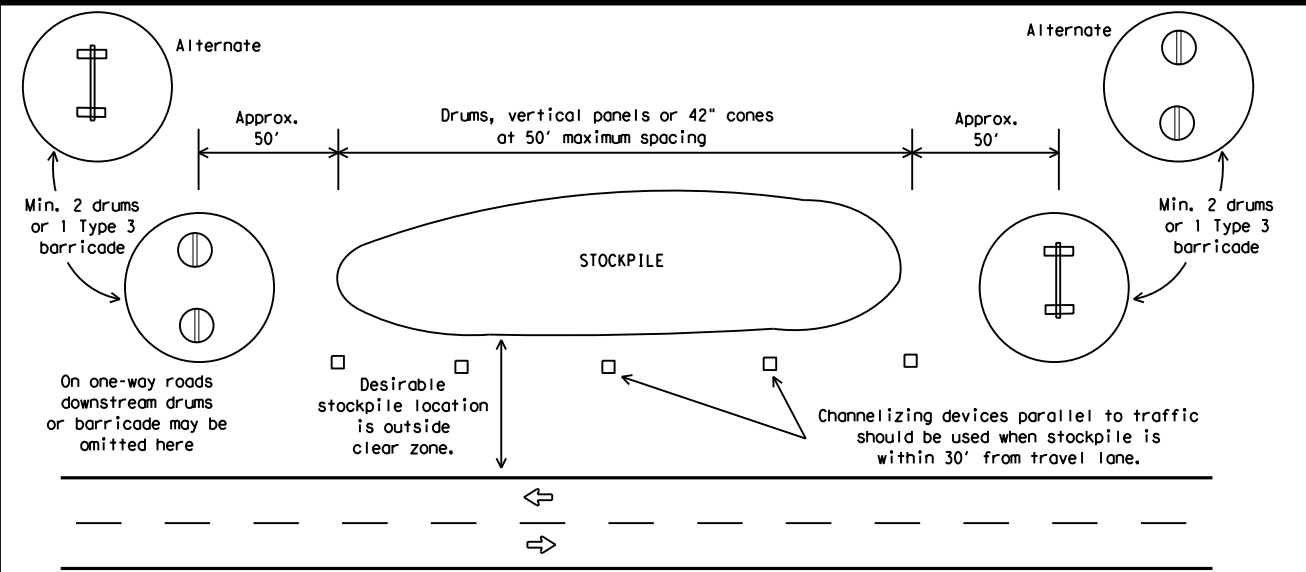

TRAFFIC CONTROL FOR MATERIAL STOCKPILES

Each roadway of a divided highway shall be barricaded in the same manner.

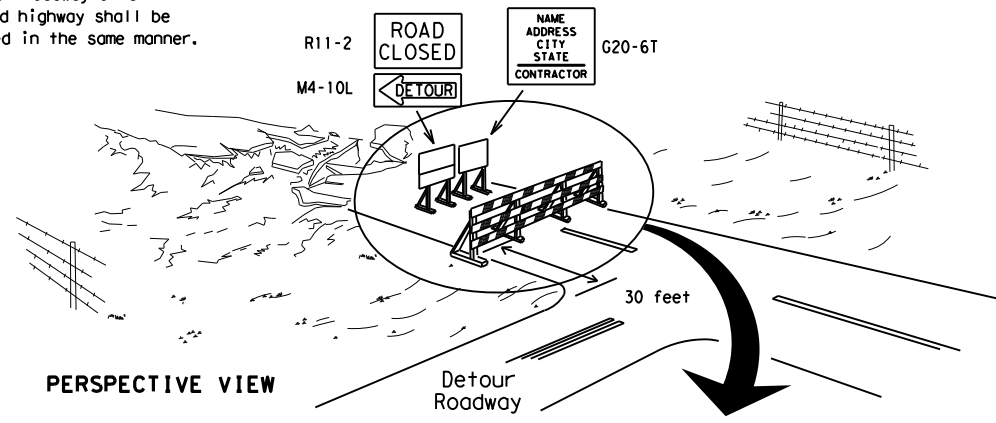

PERSPECTIVE VIEW

The three rails on Type 3 barricades shall be reflectorized orange and reflective white stripes on one side facing one-way traffic and both sides for two-way traffic. Barricade striping should slant downward in the direction of detour.

1. Signs should be mounted on independent supports at a 7 foot mounting height in center of roadway. The signs should be a minimum of 10 feet behind Type 3 Barricades.
2. Advance signing shall be as specified elsewhere in the plans.

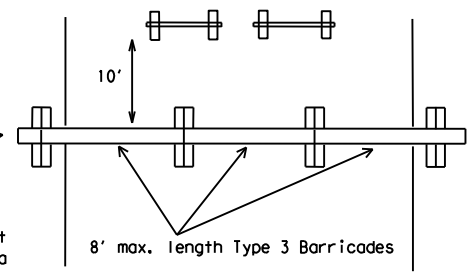

PLAN VIEW

TYPE 3 BARRICADE (POST AND SKID) TYPICAL APPLICATION

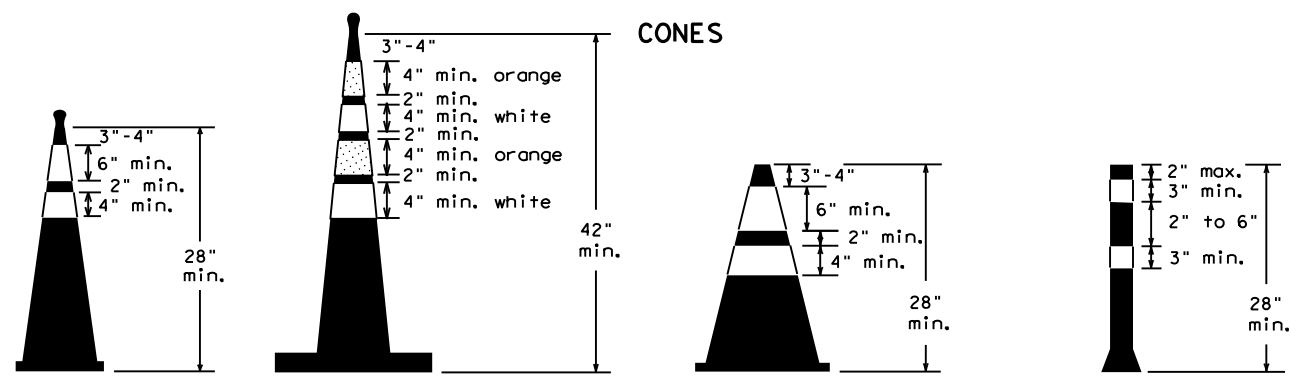

Two-Piece cones

One-Piece cones

Tubular Marker

28" Cones shall have a minimum weight of 9 1/2 lbs.
42" 2-piece cones shall have a minimum weight of 30 lbs. including base.

1. Traffic cones and tubular markers shall be predominantly orange, and meet the height and weight requirements shown above.
2. One-piece cones have the body and base of the cone molded in one consolidated unit. Two-piece cones have a cone shaped body and a separate rubber base, or ballast, that is added to keep the device upright and in place.
3. Two-piece cones may have a handle or loop extending up to 8" above the minimum height shown, in order to aid in retrieving the device.
4. Cones or tubular markers used at night shall have white or white and orange reflective bands as shown above. The reflective bands shall have a smooth, sealed outer surface and meet the requirements of Departmental Material Specification DMS-8300 Type A.
5. 28" cones and tubular markers are generally suitable for short duration and short-term stationary work as defined on BC(4). These should not be used for intermediate-term or long-term stationary work unless personnel is on-site to maintain them in their proper upright position.
6. 42" two-piece cones, vertical panels or drums are suitable for all work zone durations.
7. Cones or tubular markers used on each project should be of the same size and shape.

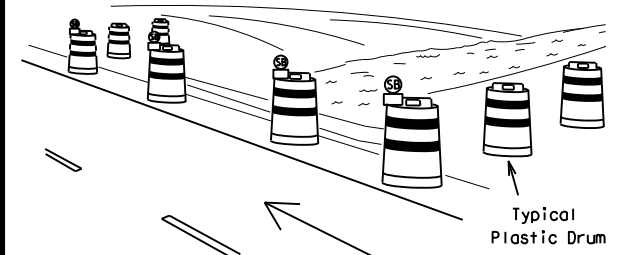

PERSPECTIVE VIEW

These drums are not required on one-way roadway

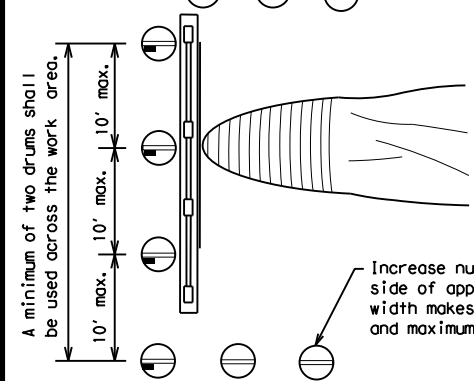

PLAN VIEW

Increase number of plastic drums on the side of approaching traffic if the crown width makes it necessary. (minimum of 2 and maximum of 4 drums)

CULVERT WIDENING OR OTHER ISOLATED WORK WITHIN THE PROJECT LIMITS

1. Where positive redirection capability is provided, drums may be omitted.
2. Plastic construction fencing may be used with drums for safety as required in the plans.
3. Vertical Panels on flexible support may be substituted for drums when the shoulder width is less than 4 feet.
4. When the shoulder width is greater than 12 feet, steady-burn lights may be omitted if drums are used.
5. Drums must extend the length of the culvert widening.

LEGEND	
	Plastic drum
	Plastic drum with steady burn light or yellow warning reflector
	Steady burn warning light or yellow warning reflector

THIS DEVICE SHALL NOT BE USED ON PROJECTS LET AFTER MARCH 2014.

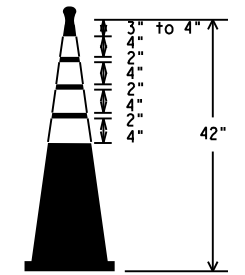

EDGE LINE CHANNELIZER

1. This device is intended only for use in place of a vertical panel to channelize traffic by indicating the edge of the travel lane. It is not intended to be used in transitions or tapers.
2. This device shall not be used to separate lanes of traffic (opposing or otherwise) or warn of objects.
3. This device is based on a 42 inch, two-piece cone with an alternate striping pattern: four 4 inch retroreflective bands, with an approximate 2 inch gap between bands. The color of the band should correspond to the color of the edgeline (yellow for left edgeline, white for right edgeline) for which the device is substituted or for which it supplements. The reflectorized bands shall be retroreflective Type A conforming to Departmental Material Specification DMS-8300, unless otherwise noted.
4. The base must weigh a minimum of 30 lbs.

SHEET 10 OF 12



BARRICADE AND CONSTRUCTION CHANNELIZING DEVICES

BC (10) - 14

FILE: bc-14.dgn	DW: TxDOT	CK: TxDOT	OW: TxDOT	CR: TxDOT
© TxDOT November 2002	CONT	SECT	JOB	HIGHWAY
REVISIONS	0083	03	056	SH 154, ETC
9-07 8-14	DIST	COUNTY	SHEET NO.	
7-13	PAR	HOPKINS, ETC	43	

DATE: FILE:

WORK ZONE PAVEMENT MARKINGS

GENERAL

- The Contractor shall be responsible for maintaining work zone and existing pavement markings, in accordance with the standard specifications and special provisions, on all roadways open to traffic within the CSJ limits unless otherwise stated in the plans.
- Color, patterns and dimensions shall be in conformance with the "Texas Manual on Uniform Traffic Control Devices" (TMUTCD).
- Additional supplemental pavement marking details may be found in the plans or specifications.
- Pavement markings shall be installed in accordance with the TMUTCD and as shown on the plans.
- When short term markings are required on the plans, short term markings shall conform with the TMUTCD, the plans and details as shown on the Standard Plan Sheet WZ(STPM).
- When standard pavement markings are not in place and the roadway is opened to traffic, DO NOT PASS signs shall be erected to mark the beginning of the sections where passing is prohibited and PASS WITH CARE signs at the beginning of sections where passing is permitted.
- All work zone pavement markings shall be installed in accordance with Item 662, "Work Zone Pavement Markings."

RAISED PAVEMENT MARKERS

- Raised pavement markers are to be placed according to the patterns on BC(12).
- All raised pavement markers used for work zone markings shall meet the requirements of Item 672, "RAISED PAVEMENT MARKERS" and Departmental Material Specification DMS-4200 or DMS-4300.

PREFABRICATED PAVEMENT MARKINGS

- Removable prefabricated pavement markings shall meet the requirements of DMS-8241.
- Non-removable prefabricated pavement markings (foil back) shall meet the requirements of DMS-8240.

MAINTAINING WORK ZONE PAVEMENT MARKINGS

- The Contractor will be responsible for maintaining work zone pavement markings within the work limits.
- Work zone pavement markings shall be inspected in accordance with the frequency and reporting requirements of work zone traffic control device inspections as required by Form 599.
- The markings should provide a visible reference for a minimum distance of 300 feet during normal daylight hours and 160 feet when illuminated by automobile low-beam headlights at night, unless sight distance is restricted by roadway geometrics.
- Markings failing to meet this criteria within the first 30 days after placement shall be replaced at the expense of the Contractor as per Specification Item 662.

REMOVAL OF PAVEMENT MARKINGS

- Pavement markings that are no longer applicable, could create confusion or direct a motorist toward or into the closed portion of the roadway shall be removed or obliterated before the roadway is opened to traffic.
- The above shall not apply to detours in place for less than three days, where flaggers and/or sufficient channelizing devices are used in lieu of markings to outline the detour route.
- Pavement markings shall be removed to the fullest extent possible, so as not to leave a discernable marking. This shall be by any method approved by TxDOT Specification Item 677 for "Eliminating Existing Pavement Markings and Markers".
- The removal of pavement markings may require resurfacing or seal coating portions of the roadway as described in Item 677.
- Subject to the approval of the Engineer, any method that proves to be successful on a particular type pavement may be used.
- Blast cleaning may be used but will not be required unless specifically shown in the plans.
- Over-painting of the markings SHALL NOT BE permitted.
- Removal of raised pavement markers shall be as directed by the Engineer.
- Removal of existing pavement markings and markers will be paid for directly in accordance with Item 677, "ELIMINATING EXISTING PAVEMENT MARKINGS AND MARKERS," unless otherwise stated in the plans.
- Black-out marking tape may be used to cover conflicting existing markings for periods less than two weeks when approved by the Engineer.

Temporary Flexible-Reflective Roadway Marker Tabs

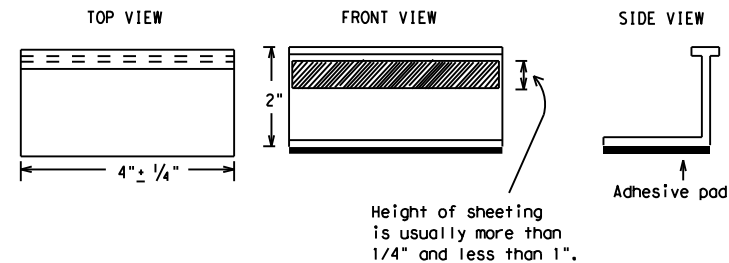

**STAPLES OR NAILS SHALL NOT BE USED TO SECURE
TEMPORARY FLEXIBLE-REFLECTIVE ROADWAY MARKER
TABS TO THE PAVEMENT SURFACE**

- Temporary flexible-reflective roadway marker tabs used as guidemarks shall meet the requirements of DMS-8242.
- Tabs detailed on this sheet are to be inspected and accepted by the Engineer or designated representative. Sampling and testing is not normally required, however at the option of the Engineer, either "A" or "B" below may be imposed to assure quality before placement on the roadway.
 - Select five (5) or more tabs at random from each lot or shipment and submit to the Construction Division, Materials and Pavement Section to determine specification compliance.
 - Select five (5) tabs and perform the following test. Affix five (5) tabs at 24 inch intervals on an asphaltic pavement in a straight line. Using a medium size passenger vehicle or pickup, run over the markers with the front and rear tires at a speed of 35 to 40 miles per hour, four (4) times in each direction. No more than one (1) out of the five (5) reflective surfaces shall be lost or displaced as a result of this test.
- Small design variances may be noted between tab manufacturers.
- See Standard Sheet WZ(STPM) for tab placement on new pavements. See Standard Sheet TCP(7-1) for tab placement on seal coat work.

RAISED PAVEMENT MARKERS USED AS GUIDEMARKS

- Raised pavement markers used as guidemarks shall be from the approved product list, and meet the requirements of DMS-4200.
- All temporary construction raised pavement markers provided on a project shall be of the same manufacturer.
- Adhesive for guidemarks shall be bituminous material hot applied or butyl rubber pad for all surfaces, or thermoplastic for concrete surfaces.

Guidemarks shall be designated as:
 YELLOW - (two amber reflective surfaces with yellow body).
 WHITE - (one silver reflective surface with white body).

DEPARTMENTAL MATERIAL SPECIFICATIONS	
PAVEMENT MARKERS (REFLECTORIZED)	DMS-4200
TRAFFIC BUTTONS	DMS-4300
EPOXY AND ADHESIVES	DMS-6100
BITUMINOUS ADHESIVE FOR PAVEMENT MARKERS	DMS-6130
PERMANENT PREFABRICATED PAVEMENT MARKINGS	DMS-8240
TEMPORARY REMOVABLE, PREFABRICATED PAVEMENT MARKINGS	DMS-8241
TEMPORARY FLEXIBLE, REFLECTIVE ROADWAY MARKER TABS	DMS-8242

A list of prequalified reflective raised pavement markers, non-reflective traffic buttons, roadway marker tabs and other pavement markings can be found at the Material Producer List web address shown on BC(1).

DISCLAIMER: The use of this standard is governed by the "Texas Engineering Practice Act". No warranty of any kind is made by TxDOT for any purpose whatsoever. TxDOT assumes no responsibility for the conversion of this standard to other formats or for incorrect results or damages resulting from its use.

DATE:
FILE:

SHEET 11 OF 12



BARRICADE AND CONSTRUCTION PAVEMENT MARKINGS

BC(11) - 14

FILE: bc-14.dgn	DN: TxDOT	CR: TxDOT	OW: TxDOT	CK: TxDOT
© TxDOT February 1998	CONT	SECT	JOB	HIGHWAY
REVISIONS		0083	03	056
2-98	9-07			SH 154, ETC
1-02	7-13			
11-02	8-14	PAR	HOPKINS, ETC	SHEET NO. 44

105

PAVEMENT MARKING PATTERNS



REFLECTORIZED PAVEMENT MARKINGS - PATTERN A

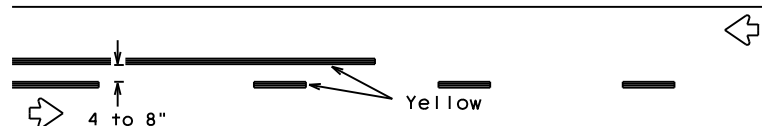

REFLECTORIZED PAVEMENT MARKINGS - PATTERN B

Pattern A is the TXDOT Standard, however Pattern B may be used if approved by the Engineer. Prefabricated markings may be substituted for reflectorized pavement markings.

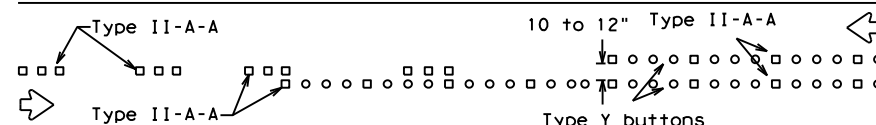

RAISED PAVEMENT MARKERS - PATTERN A

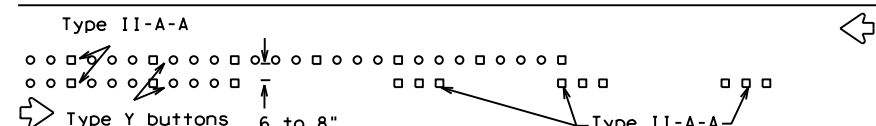

RAISED PAVEMENT MARKERS - PATTERN B

CENTER LINE & NO-PASSING ZONE BARRIER LINES FOR TWO-LANE, TWO-WAY HIGHWAYS

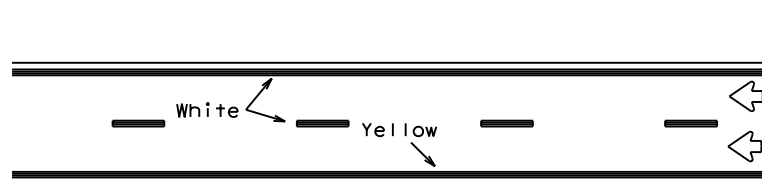

REFLECTORIZED PAVEMENT MARKINGS

Prefabricated markings may be substituted for reflectorized pavement markings.

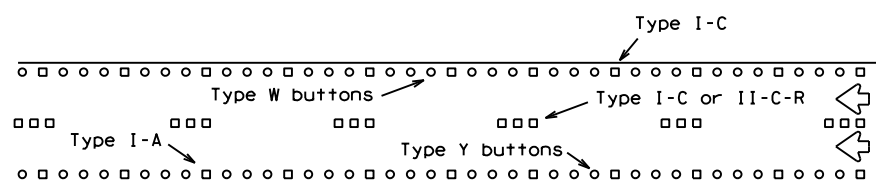

RAISED PAVEMENT MARKERS

EDGE & LANE LINES FOR DIVIDED HIGHWAY

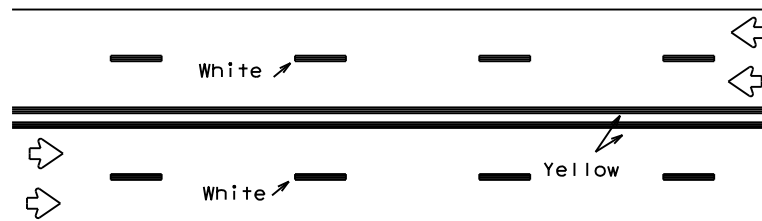

REFLECTORIZED PAVEMENT MARKINGS

Prefabricated markings may be substituted for reflectorized pavement markings.

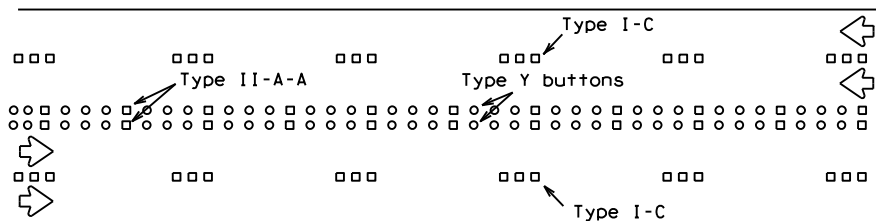

RAISED PAVEMENT MARKERS

LANE & CENTER LINES FOR MULTILANE UNDIVIDED HIGHWAYS

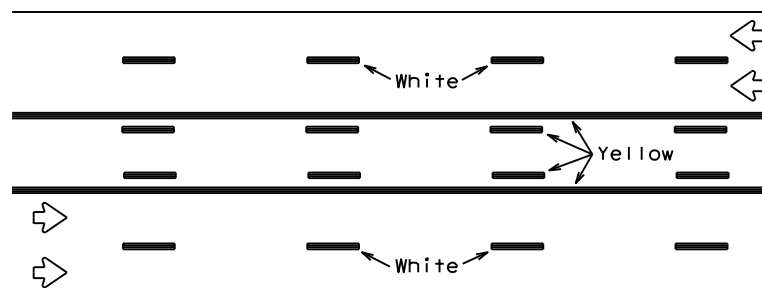

REFLECTORIZED PAVEMENT MARKINGS

Prefabricated markings may be substituted for reflectorized pavement markings.

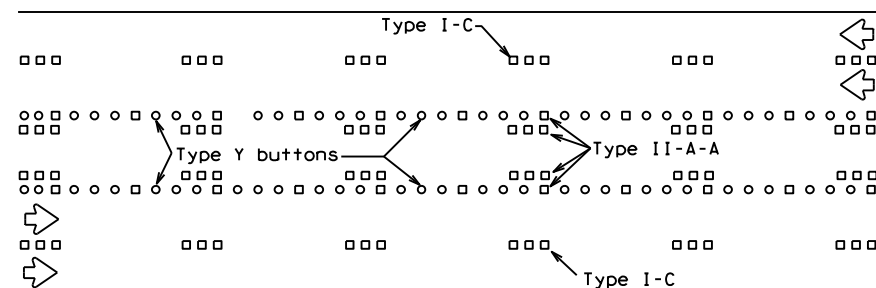

RAISED PAVEMENT MARKERS

TWO-WAY LEFT TURN LANE

STANDARD WORK ZONE PAVEMENT MARKINGS DETAILS

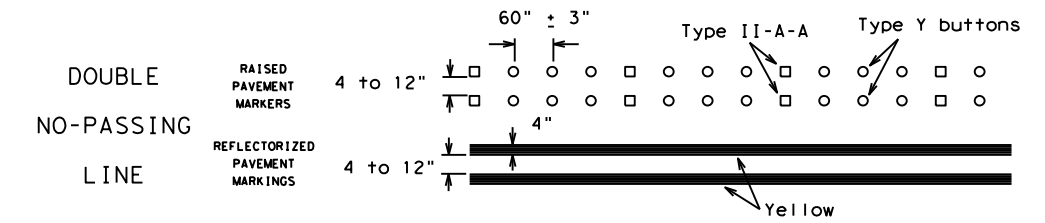

SOLID LINES

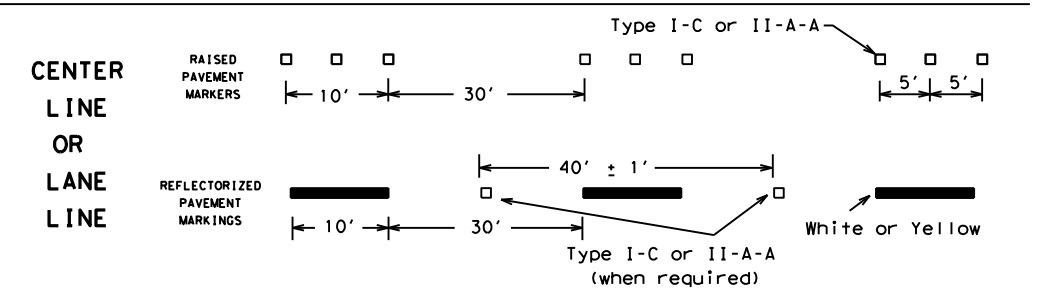
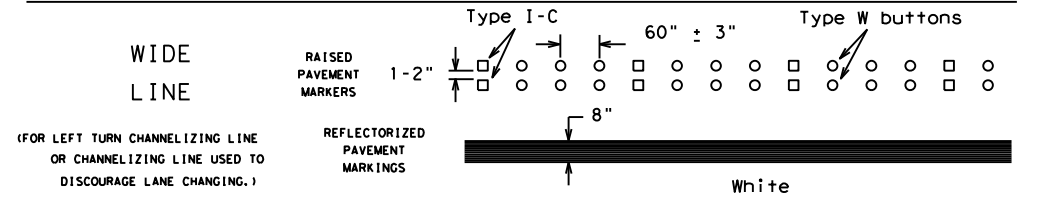
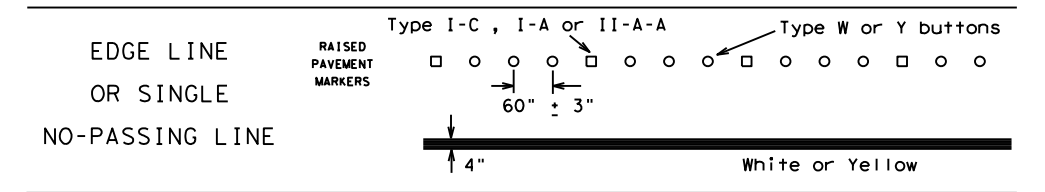

BROKEN LINES

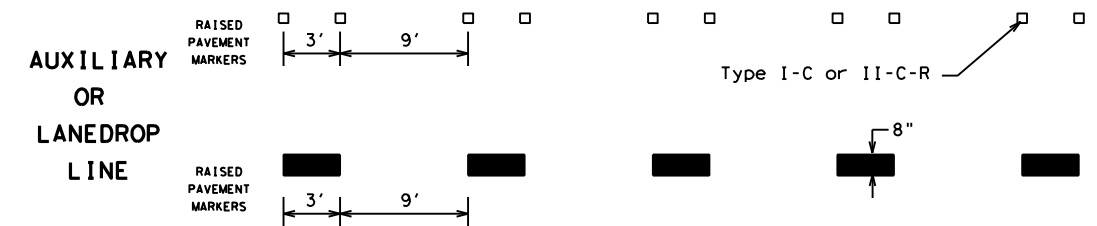

REMOVABLE MARKINGS WITH RAISED PAVEMENT MARKERS

If raised pavement markers are used to supplement REMOVABLE markings, the markers shall be applied to the top of the tape at the approximate mid length of tape used for broken lines or at 20 foot spacing for solid lines. This allows an easier removal of raised pavement markers and tape.

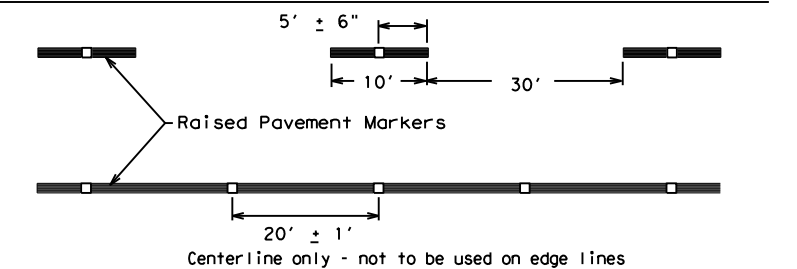

SHEET 12 OF 12



BARRICADE AND CONSTRUCTION PAVEMENT MARKING PATTERNS

BC (12) - 14

FILE: bc-14.dgn	DN: TxDOT	CK: TxDOT	DW: TxDOT	CK: TxDOT
©TxDOT February 1998	CONT	SECT	JOB	HIGHWAY
REVISIONS	0083	03	056	SH 154, ETC
1-97 9-07	DIST	COUNTY	SHEET NO.	
2-98 7-13	PAR	HOPKINS, ETC	45	
11-02 8-14				

DISCLAIMER: The use of this standard is governed by the "Texas Engineering Practice Act". No warranty of any kind is made by TxDOT for any purpose whatsoever. TxDOT assumes no responsibility for the conversion of this standard to other formats or for incorrect results or damages resulting from its use.

DATE: FILE:

DISCLAIMER: This use of this standard is governed by the "Texas Engineering Practice Act". No warranty of any kind is made by TxDOT for any purpose whatsoever. TxDOT assumes no responsibility for the conversion of this standard to other formats or for incorrect results or damages resulting from its use.

10/04/2020
JF111111\SHA\dgnfiles\Our_Standards_2012\Maint\ec116.dgn

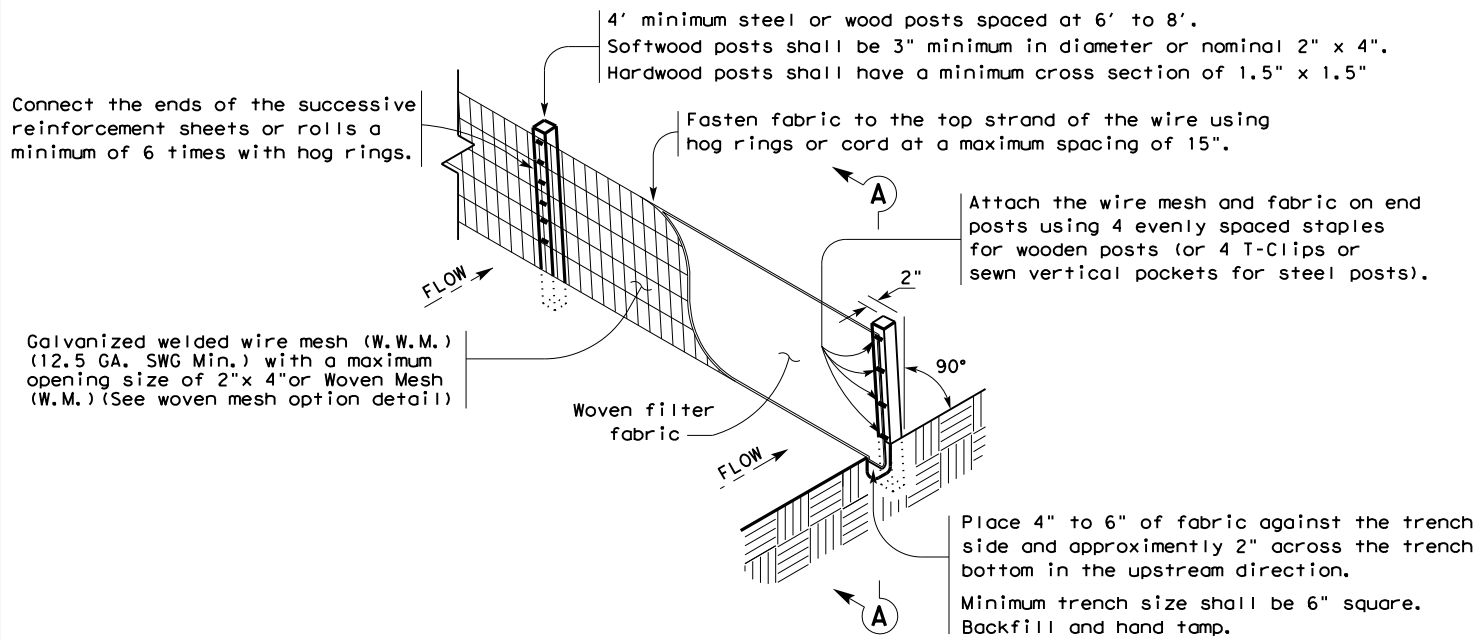

TEMPORARY SEDIMENT CONTROL FENCE

SCF

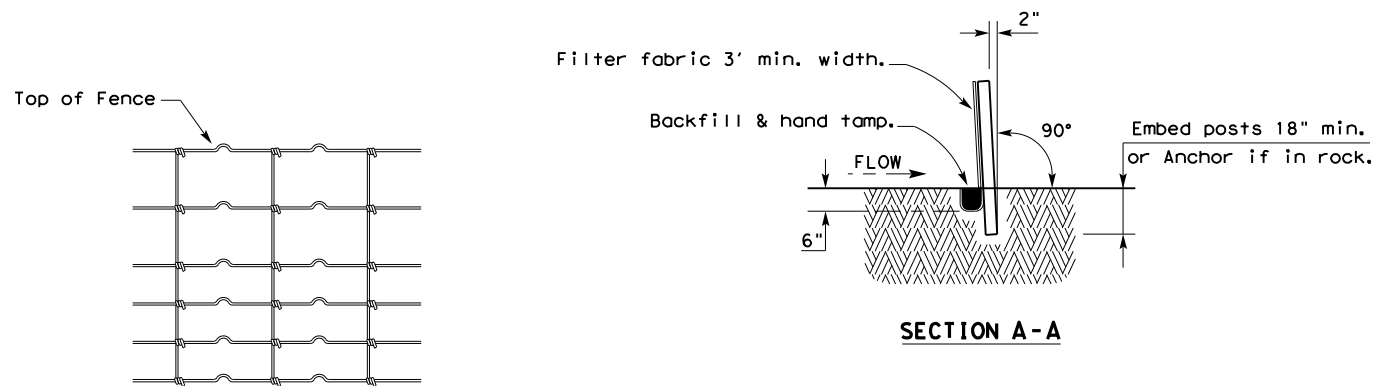

HINGE JOINT KNOT WOVEN MESH (OPTION) DETAIL

Galvanized hinge joint knot woven mesh (12.5 GA. SWG Min.) requires a minimum of five horizontal wires spaced at a maximum of 12 inches apart and all vertical wires spaced at a maximum of 12 inches apart.

SEDIMENT CONTROL FENCE USAGE GUIDELINES

A sediment control fence may be constructed near the downstream perimeter of a disturbed area along a contour to intercept sediment from overland runoff. A 2 year storm frequency may be used to calculate the flow rate to be filtered.

Sediment control fence should be sized to filter a maximum flow through rate of 100 GPM/FT². Sediment control fence is not recommended to control erosion from a drainage area larger than 2 acres.

LEGEND

Sediment Control Fence

SCF

GENERAL NOTES

1. Vertical tracking is required on projects where soil distributing activities have occurred unless otherwise approved.
2. Perform vertical tracking on slopes to temporarily stabilize soil.
3. Provide equipment with a track undercarriage capable of producing linear soil impressions measuring a minimum of 12" in length by 2" to 4" in width by 1/2" to 2" in depth.
4. Do not exceed 12" between track impressions.
5. Install continuous linear track impressions where the minimum 12" length impressions are perpendicular to the slope or direction of water flow.

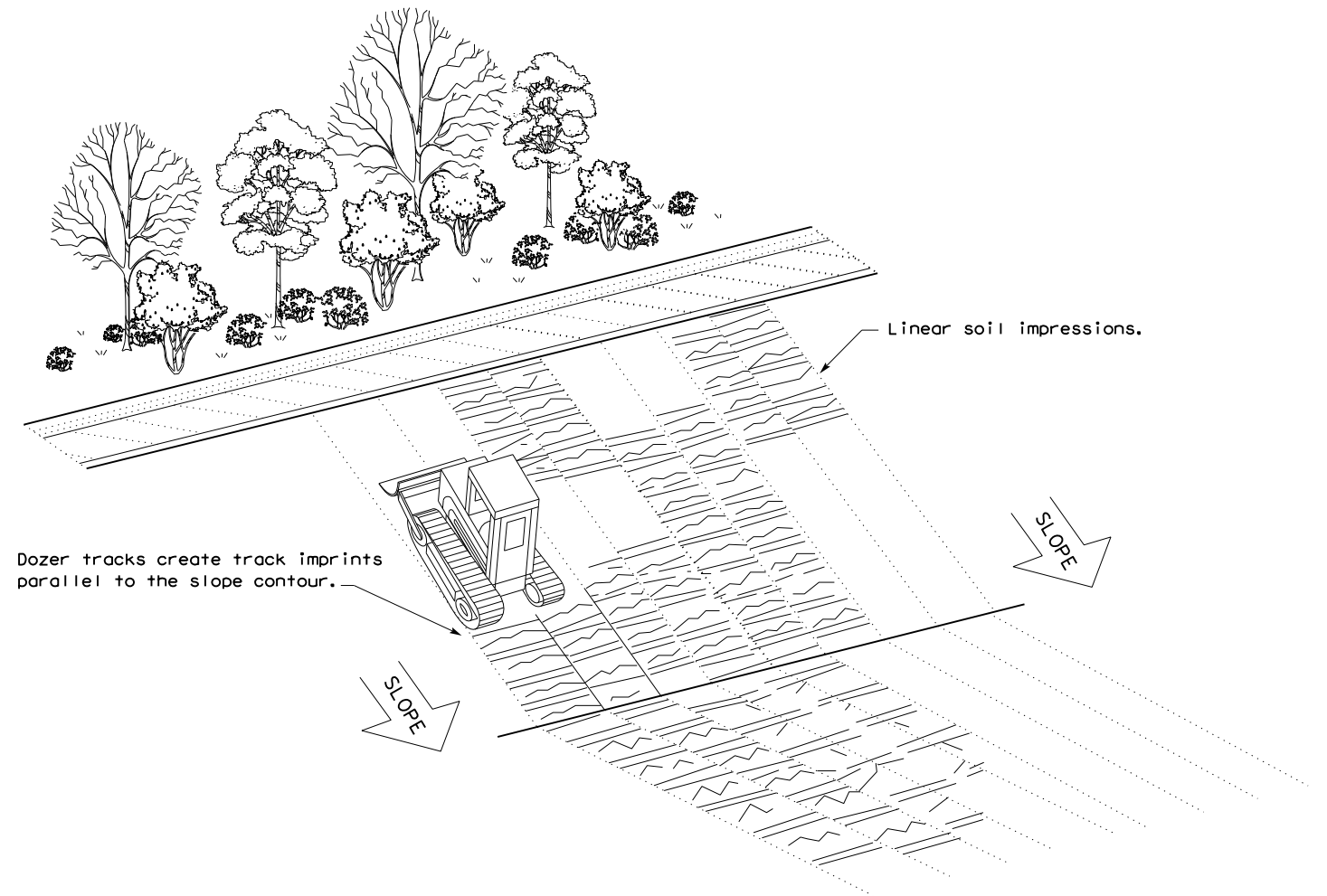

VERTICAL TRACKING

				Design Division Standard	
TEMPORARY EROSION, SEDIMENT AND WATER POLLUTION CONTROL MEASURES FENCE & VERTICAL TRACKING EC(1)-16					
FILE: ec116	DN: TxDOT	CK: KM	DW: VP	DN/CK: LS	
© TxDOT: JULY 2016	CONT	SECT	JOB	HIGHWAY	
REVISIONS	0083	03	056	SH 154, ETC	
	DIST	COUNTY	SHEET NO.		
	PAR	HOPKINS, ETC	46		

DATE: 12/4/2020
 FILE: U:\TAUSHA\dgnfiles\our Standards 2012\Maint\epic.dgn
 DISCLAIMER: The use of this standard is governed by the "Texas Engineering Practice Act". No warranty of any kind is made by TxDOT for any purpose whatsoever. TxDOT assumes no responsibility for the conversion of this standard to other formats or for incorrect results or damages resulting from its use.

I. STORMWATER POLLUTION PREVENTION-CLEAN WATER ACT SECTION 402

TPDES TXR 150000: Stormwater Discharge Permit or Construction General Permit required for projects with 1 or more acres disturbed soil. Projects with any disturbed soil must protect for erosion and sedimentation in accordance with Item 506.

List MS4 Operator(s) that may receive discharges from this project. They may need to be notified prior to construction activities.

-
- No Action Required Required Action

Action No.

- Prevent stormwater pollution by controlling erosion and sedimentation in accordance with TPDES Permit TXR 150000
- Comply with the SW3P and revise when necessary to control pollution or required by the Engineer.
- Post Construction Site Notice (CSN) with SW3P information on or near the site, accessible to the public and TCEQ, EPA or other inspectors.
- When Contractor project specific locations (PSL's) increase disturbed soil area to 5 acres or more, submit NOI to TCEQ and the Engineer.

II. WORK IN OR NEAR STREAMS, WATERBODIES AND WETLANDS CLEAN WATER ACT SECTIONS 401 AND 404

USACE Permit required for filling, dredging, excavating or other work in any water bodies, rivers, creeks, streams, wetlands or wet areas.

The Contractor must adhere to all of the terms and conditions associated with the following permit(s):

- No Permit Required
- Nationwide Permit 14 - PCN not Required (less than 1/10th acre waters or wetlands affected)
- Nationwide Permit 14 - PCN Required (1/10 to <1/2 acre, 1/3 in tidal waters)
- Individual 404 Permit Required
- Other Nationwide Permit Required: NWP# _____

Required Actions: List waters of the US permit applies to, location in project and check Best Management Practices planned to control erosion, sedimentation and post-project TSS.

-
-
-
-

The elevation of the ordinary high water marks of any areas requiring work to be performed in the waters of the US requiring the use of a nationwide permit can be found on the Bridge Layouts.

Best Management Practices:

Erosion	Sedimentation	Post-Construction TSS
<input type="checkbox"/> Temporary Vegetation	<input checked="" type="checkbox"/> Silt Fence	<input type="checkbox"/> Vegetative Filter Strips
<input type="checkbox"/> Blankets/Matting	<input type="checkbox"/> Rock Berm	<input type="checkbox"/> Retention/Irrigation Systems
<input type="checkbox"/> Mulch	<input type="checkbox"/> Triangular Filter Dike	<input type="checkbox"/> Extended Detention Basin
<input type="checkbox"/> Sodding	<input type="checkbox"/> Sand Bag Berm	<input type="checkbox"/> Constructed Wetlands
<input type="checkbox"/> Interceptor Swale	<input type="checkbox"/> Straw Bale Dike	<input type="checkbox"/> Wet Basin
<input type="checkbox"/> Diversion Dike	<input type="checkbox"/> Brush Berms	<input type="checkbox"/> Erosion Control Compost
<input type="checkbox"/> Erosion Control Compost	<input type="checkbox"/> Erosion Control Compost	<input type="checkbox"/> Mulch Filter Berm and Socks
<input type="checkbox"/> Mulch Filter Berm and Socks	<input type="checkbox"/> Mulch Filter Berm and Socks	<input type="checkbox"/> Compost Filter Berm and Socks
<input type="checkbox"/> Compost Filter Berm and Socks	<input type="checkbox"/> Compost Filter Berm and Socks	<input type="checkbox"/> Vegetation Lined Ditches
	<input type="checkbox"/> Stone Outlet Sediment Traps	<input type="checkbox"/> Sand Filter Systems
	<input type="checkbox"/> Sediment Basins	<input type="checkbox"/> Grassy Swales

III. CULTURAL RESOURCES

Refer to TxDOT Standard Specifications in the event historical issues or archeological artifacts are found during construction. Upon discovery of archeological artifacts (bones, burnt rock, flint, pottery, etc.) cease work in the immediate area and contact the Engineer immediately.

- No Action Required Required Action

Action No.

-
-
-
-

IV. VEGETATION RESOURCES

Preserve native vegetation to the extent practical. Contractor must adhere to Construction Specification Requirements Specs 162, 164, 192, 193, 506, 730, 751, 752 in order to comply with requirements for invasive species, beneficial landscaping, and tree/brush removal commitments.

- No Action Required Required Action

Action No.

-
-
-
-

V. FEDERAL LISTED, PROPOSED THREATENED, ENDANGERED SPECIES, CRITICAL HABITAT, STATE LISTED SPECIES, CANDIDATE SPECIES AND MIGRATORY BIRDS.

- No Action Required Required Action

Action No.

-
-
-
-

If any of the listed species are observed, cease work in the immediate area, do not disturb species or habitat and contact the Engineer immediately. The work may not remove active nests from bridges and other structures during nesting season of the birds associated with the nests. If caves or sinkholes are discovered, cease work in the immediate area, and contact the Engineer immediately.

LIST OF ABBREVIATIONS

BMP: Best Management Practice	SPCC: Spill Prevention Control and Countermeasure
CGP: Construction General Permit	SW3P: Storm Water Pollution Prevention Plan
DSHS: Texas Department of State Health Services	PCN: Pre-Construction Notification
FHWA: Federal Highway Administration	PSL: Project Specific Location
MOA: Memorandum of Agreement	TCEQ: Texas Commission on Environmental Quality
MOU: Memorandum of Understanding	TPDES: Texas Pollutant Discharge Elimination System
MS4: Municipal Separate Stormwater Sewer System	TPWD: Texas Parks and Wildlife Department
MBTA: Migratory Bird Treaty Act	TxDOT: Texas Department of Transportation
NOT: Notice of Termination	T&E: Threatened and Endangered Species
NWP: Nationwide Permit	USACE: U.S. Army Corps of Engineers
NOI: Notice of Intent	USFWS: U.S. Fish and Wildlife Service

VI. HAZARDOUS MATERIALS OR CONTAMINATION ISSUES

General (applies to all projects):

Comply with the Hazard Communication Act (the Act) for personnel who will be working with hazardous materials by conducting safety meetings prior to beginning construction and making workers aware of potential hazards in the workplace. Ensure that all workers are provided with personal protective equipment appropriate for any hazardous materials used. Obtain and keep on-site Material Safety Data Sheets (MSDS) for all hazardous products used on the project, which may include, but are not limited to the following categories: Paints, acids, solvents, asphalt products, chemical additives, fuels and concrete curing compounds or additives. Provide protected storage, off bare ground and covered, for products which may be hazardous. Maintain product labelling as required by the Act. Maintain an adequate supply of on-site spill response materials, as indicated in the MSDS. In the event of a spill, take actions to mitigate the spill as indicated in the MSDS, in accordance with safe work practices, and contact the District Spill Coordinator immediately. The Contractor shall be responsible for the proper containment and cleanup of all product spills.

Contact the Engineer if any of the following are detected:

- * Dead or distressed vegetation (not identified as normal)
- * Trash piles, drums, canister, barrels, etc.
- * Undesirable smells or odors
- * Evidence of leaching or seepage of substances

Does the project involve any bridge class structure rehabilitation or replacements (bridge class structures not including box culverts)?

- Yes No

If "No", then no further action is required.

If "Yes", then TxDOT is responsible for completing asbestos assessment/inspection.

Are the results of the asbestos inspection positive (is asbestos present)?

- Yes No

If "Yes", then TxDOT must retain a DSHS licensed asbestos consultant to assist with the notification, develop abatement/mitigation procedures, and perform management activities as necessary. The notification form to DSHS must be postmarked at least 15 working days prior to scheduled demolition.

If "No", then TxDOT is still required to notify DSHS 15 working days prior to any scheduled demolition.

In either case, the Contractor is responsible for providing the date(s) for abatement activities and/or demolition with careful coordination between the Engineer and asbestos consultant in order to minimize construction delays and subsequent claims.

Any other evidence indicating possible hazardous materials or contamination discovered on site. Hazardous Materials or Contamination Issues Specific to this Project:

- No Action Required Required Action

Action No.

-
-
-

VII. OTHER ENVIRONMENTAL ISSUES

(includes regional issues such as Edwards Aquifer District, etc.)

- No Action Required Required Action

Action No.

-
-
-

 Texas Department of Transportation		Design Division Standard			
<h2 style="margin: 0;">ENVIRONMENTAL PERMITS, ISSUES AND COMMITMENTS</h2> <h1 style="margin: 0;">EPIC</h1>					
FILE: epic.dgn	DN: TxDOT	CK: RG	DW: VP	CK: AR	
©TxDOT: February 2015		CONT	SECT	JOB	HIGHWAY
12-12-2011 (DS) REVISIONS		0083	03	056	SH 154, ETC
05-07-14 ADDED NOTE SECTION IV.		DIST	COUNTY	SHEET NO.	
01-23-2015 SECTION I CHANGED ITEM 1122 TO ITEM 506, ADDED GRASSY SWALES.		PAR	HOPKINS, ETC	47	

C:\S:\0083-03-056 etc.\SW3P.dgn
 DATE: 12/4/2020 9:09:02 AM
 FILE: t:\part\traf\tausha\csj\0083-03-056 etc.\SW3P.dgn

SITE DESCRIPTION

PROJECT LIMITS: SH 154 FROM SH 11 TO BILL BRADFORD RD (RADIO RD)
 US 69 FROM SH 276 TO FM 2795
 SH 19 AT FM 2324

PROJECT DESCRIPTION: IMPROVE AND UPGRADE TRAFFIC SIGNALS

MAJOR SOIL DISTURBING ACTIVITIES:

INCLUDES FOUNDATIONS, EROSION AND SEDIMENTARY CONTROLS, AND RAISED ISLANDS.

TOTAL PROJECT AREA: 5.4 ACRES

TOTAL AREA TO BE DISTURBED: 0.29 AC (5.37%)

EXISTING CONDITION OF SOIL & VEGETATIVE COVER AND % OF EXISTING VEGETATIVE COVER:

SH 154 FROM SH 11 TO BILL BRADFORD (RADIO ROAD)
 Freestone Fine Sandy Loam, 1 to 3 percent slopes, moderately well drained, nonsaline to very slightly saline;
 Nahatche Soils, 0 to 1 percent slopes, somewhat poorly drained, nonsaline to very slightly saline.

US 69 FROM SH 276 TO FM 2795
 Annona-Raino Complex, 0 to 1 percent slopes, moderately well drained, nonsaline to very slightly saline;
 Freestone Fine Sandy Loam, 1 to 3 percent slopes, moderately well drained, nonsaline to very slightly saline;
 Wolfpen Loamy Fine Sand, 2 to 5 percent slopes, well drained, nonsaline.

SH 19 AT FM 2324
 Wolfpen Loamy Fine Sandy, 2 to 5 percent slopes, well drained, nonsaline;
 Lufkin-Raino Complex, 0 to 1 percent slopes, moderately well drained, nonsaline to slightly saline.

NAME OF RECEIVING WATERS:

SH 154 FROM SH 11 TO BILL BRADFORD RD (RADIO RD)
 Segment ID 0303D
 Segment Name Rock Creek
 Segment Class Unclassified
 Segment Type Freshwater Stream
 Segment Description Rock Creek - from the confluence with southwest corner of Sulphur Springs
 approximately 2 mi southeast of the Intersection of I-30 and State Hwy 19
 Basin Name Sulphur River Basin

US 69 FROM SH 276 TO FM 2795
 SH 19 @ FM 2324
 Segment ID 0506B
 Segment Name Sandy Creek
 Segment Class Unclassified
 Segment Type Freshwater Stream
 Segment Description Sandy Creek - perennial stream from the confluence of Glade Creek upstream to
 the confluence of an unnamed tributary 0.3 km below SH 19
 Basin Name Sabine River Basin

EROSION AND SEDIMENT CONTROLS

SOIL STABILIZATION PRACTICES & STRUCTURAL PRACTICES:

EROSION CONTROL:

- TEMPORARY SEEDING
- PERMANENT PLANTING, SODDING, OR SEEDING
- MULCHING
- SOIL RETENTION BLANKET
- BUFFER ZONES
- PRESERVATION OF NATURAL RESOURCES

OTHER:

DISTURBED AREAS ON WHICH CONSTRUCTION ACTIVITY HAS CEASED (TEMPORARILY OR PERMANENTLY) SHALL BE STABILIZED WITHIN 14 DAYS UNLESS ACTIVITIES ARE SCHEDULED TO RESUME AND DO WITHIN 21 DAYS.

SEDIMENTATION CONTROL:

- SILT FENCES
- HAY BALES
- ROCK BERMS
- DIVERSION, INTERCEPTOR, OR PERIMETER DIKES
- DIVERSION, INTERCEPTOR, OR PERIMETER SWALES
- DIVERSION DIKE AND SWALE COMBINATIONS
- PIPE SLOPE DRAINS
- PAVED FLUMES
- ROCK BEDDING AT CONSTRUCTION EXIT
- TIMBER MATTING AT CONSTRUCTION EXIT
- CHANNEL LINERS
- SEDIMENT TRAPS
- SEDIMENT BASINS
- STORM INLET SEDIMENT TRAP
- STONE OUTLET STRUCTURES
- CURBS AND GUTTERS
- STORM SEWERS
- VELOCITY CONTROL DEVICES

POST-CONSTRUCTION CONTROLS:

- RETENTION / IRRIGATION
- EXTENDED DETENTION BASIN (ie: ROCK BERMS)
- VEGETATIVE FILTER STRIPS
- GRASSY SWALES
- VEGETATIVE LINED DRAINAGE DITCHES
- CONSTRUCTED WET LANDS
- WET BASINS
- SAND FILTER SYSTEMS

NARRATIVE - SEQUENCE OF CONSTRUCTION (STORM WATER MANAGEMENT) ACTIVITIES:

THE ORDER OF ACTIVITIES WILL BE AS FOLLOWS:

INSTALL EROSION AND SEDIMENTATION CONTROLS PRIOR TO SOIL DISTURBANCE WHENEVER POSSIBLE.

ONCE BEGUN, EARTHWORK ACTIVITIES SHALL BE PROGRESSED WITHOUT DELAY, UNLESS APPROVED BY THE ENGINEER, UNTIL FINAL GRADING IS ACCOMPLISHED.

REMARKS: Disposal areas, stockpiles, and haul roads shall be constructed in a manner that will minimize and control the amount of sediment that may enter receiving waters. Disposal areas shall not be located in any wetland, waterbody or streambed.
 The Contractor shall designate a location for, construct, and maintain an area for concrete mixing, handling and delivery equipment to wash out.
 Construction staging areas and vehicle maintenance areas shall be constructed by the Contractor in a manner to minimize the runoff of pollutants.
 All waterways shall be cleared as soon as practicable of temporary embankment, temporary bridges, matting, falsework, piling, debris or other obstructions placed during construction operations that are not a part of the finished work.

MAINTENANCE: All erosion and sediment controls will be maintained in good working order. If a repair is necessary, it will be done at the earliest date possible, but no later than 7 calendar days after the surrounding exposed ground has dried sufficiently to prevent further damage from heavy equipment. The areas adjacent to creeks and drainageways shall have priority followed by devices protecting storm sewer inlets.

INSPECTION: An inspection will be performed by a TxDOT Inspector at least once every seven (7) calendar days. An inspection and maintenance report will be made per each inspection. Stormwater controls will be modified as directed by the Engineer based on these reports.

OTHER EROSION AND SEDIMENT CONTROLS:

WASTE MATERIALS: All trash and construction debris from the job site will be disposed of by the Contractor at a local dump. No construction materials will be buried on site.

HAZARDOUS WASTE (INCLUDING SPILL REPORTING): Any hazardous waste spills shall be reported to the TxDOT Safety Officer in Paris. It shall be the responsibility of the waste owner to provide for the required clean-up. If the owner cannot be determined, the district laboratory shall direct in the clean-up operation.

SANITARY WASTE: Any sanitary waste shall be collected from portable units as necessary or as required by local regulation by a licensed sanitary waste management contractor. All sanitary waste from permanent sites will be collected by local sanitary sewer systems.

OFFSITE VEHICLE TRACKING:

- HAUL ROADS DAMPENED FOR DUST CONTROL
- LOADED HAUL TRUCKS TO BE COVERED WITH TARPAULIN
- EXCESS DIRT ON ROAD REMOVED DAILY
- STABILIZED CONSTRUCTION ENTRANCE

THE CONTRACTOR IS RESPONSIBLE FOR ENSURING THAT ALL SUBCONTRACTORS ARE AWARE OF AND COMPLY WITH ALL COMPONENTS OF THE SW3P.

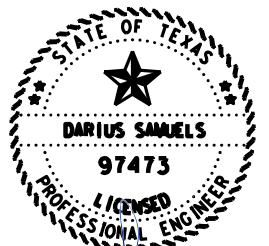

Darius Samuels
 12/16/2020

SH 154, ETC
 SW3P

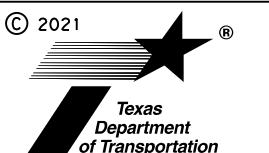

CONT	SECT	JOB	HIGHWAY
0083	03	056	SH 154, ETC
DIST	COUNTY	SHEET NO.	
PAR	HOPKINS, ETC	48	