

STATE OF TEXAS
DEPARTMENT OF TRANSPORTATION

FHWA	PROJECT NO.		SHEET NO.
TEXAS	6442-70-001		1
DIVISION	DISTRICT	COUNTY	
TEXAS	LFK	SABINE	
CONTROL	SECTION	JOB	HIGHWAY NO.
6442	70	001	US 96, ETC.

SEE SHEET 2 FOR INDEX OF SHEETS

PLANS OF PROPOSED
STATE HIGHWAY ROUTINE MAINTENANCE CONTRACT
TYPE OF WORK:
REPAIR AND MAINTENANCE OF METAL BEAM GUARD FENCE

6442-70-001

US 96, ETC.

SABINE COUNTY

LIMITS: VARIOUS LOCATIONS THROUGHOUT THE SABINE COUNTY MAINTENANCE SECTION

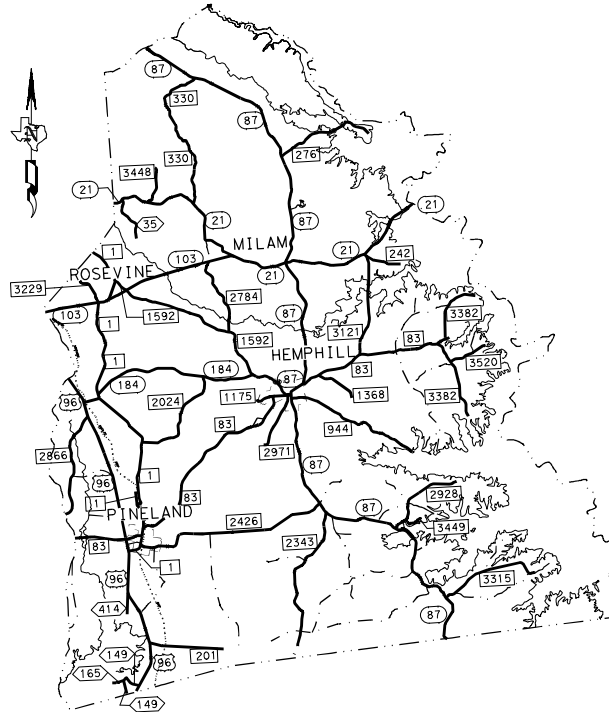

WORK LOCATION MAP

N. T. S.

BARRICADES AND WARNING SIGNS

PROJECT LIMIT BARRICADES WILL NOT BE REQUIRED.
THE CONTRACTOR SHALL PROVIDE AND ERECT WARNING SIGNS IN ACCORDANCE WITH THE BARRICADE & CONSTRUCTION STANDARDS, TCF STANDARDS, THE "TEXAS MANUAL ON UNIFORM TRAFFIC CONTROL DEVICES" AND AS DIRECTED.

© 2023



RECOMMENDED FOR LETTING:

DocuSigned by:
Jeremy King, P.E. 5/17/2023
DISTRICT MAINTENANCE ENGINEER DATE
APPROVED FOR LETTING: 5135292FE4184A4...

DocuSigned by:
Z. Boyer, P.E. 5/17/2023
DIRECTOR OF OPERATIONS DATE

SPECIFICATIONS ADOPTED BY THE TEXAS DEPARTMENT OF TRANSPORTATION NOVEMBER 1, 2014 AND SPECIAL SPECIFICATION ITEMS INCLUDED IN THE CONTRACT SHALL GOVERN ON THIS PROJECT.

© 2023 BY TEXAS DEPARTMENT OF TRANSPORTATION. ALL RIGHTS RESERVED.

5/15/2023 8:01:15 AM T:\LF\DOM\Maint\contracts\o_rmc - Routine Maintenance Contracts\FY23 Plans\6442-70-001 Sabine MBGF\DCN\TITLE_Sabine_MBGF_6411-49-001.dgn

INDEX OF SHEETS

<u>SHEET NO.</u>	<u>DESCRIPTION</u>
<u>GENERAL</u>	
1	TITLE SHEET
2	INDEX OF SHEETS
3, 3A-3C	GENERAL NOTES
4, 4A	ESTIMATE AND QUANTITY SHEET
5	QUANTITY SUMMARY
<u>TRAFFIC CONTROL PLAN</u>	
* 6-17	BC (1)-21 THRU BC (12)-21
* 18-23	TCP (2-1)-18 THRU TCP (2-6)-18
* 24	WZ (RS)-22
<u>ROADWAY DETAILS</u>	
* 25	MBGF-19
* 26	MBGF (SR)-19
* 27	MBGF (T101)-19
* 28	MBGF (TR)-19
* 29	GF (31)-19
* 30	GF (31)DAT-19
* 31	GF (31)LS-19
* 32	GF (31)T101-19
* 33	GF (31)TRTL2-19
* 34-35	GF (31)TRTL3-20
* 36	CCCG-22
* 37	TRACC (W)-16
* 38	D & OM (1)-20
* 39	D & OM (3)-20
* 40	D & OM (VIA)-20
* 41	SGT (10S) 31-16
* 42	SGT (11S) 31-18
* 43	SGT (12S) 31-18
* 44	RAIL-ADJ (A)-19
<u>BRIDGE ITEMS</u>	
* 45	T631-CM
* 46-47	T631
* 48-49	T631LS
* 50	BED (28)-19
* 51	BED-14
* 52	T202TR (MOD)
* 53	T2/T201TR (MOD)
<u>INFORMATIONAL SHEETS</u>	
54	"AS BUILT" TYPE T6
55	"AS BUILT" TYPE T101
56-58	"AS BUILT" TYPE T101RC (MOD)
<u>ENVIRONMENTAL SHEETS</u>	
59	EPIC



THE STANDARD SHEETS SPECIFICALLY IDENTIFIED BY * HAVE BEEN SELECTED BY ME OR UNDER MY RESPONSIBLE SUPERVISION AS BEING APPLICABLE TO THIS PROJECT.

DocuSigned by:
Jeremy King, P.E. 5/17/2023
 ENGINEER NAME P.E. DATE
 5135292FE4184A4...

INDEX OF SHEETS

©2023			
CONT	SECT	JOB	HIGHWAY
6442	70	001	US 96, ETC.
DIST	COUNTY	SHEET NO.	
LFK	SABINE	2	

5/15/2023 8:04:28 AM
 T:\LF\RD00\Maint\Contracts\FY23 Plans\6442-70-001 SabIne MBGF.DGN\INDEX_MBGF_6411-49-001.dgn

Project Number: RMC 6422-70-001**Control: 6442-70-001****County: SABINE****Highway: US 96, ETC.****GENERAL NOTES:**

PROJECT DESCRIPTION: This project consists of Repair/Upgrade Metal Beam Guard Fence, Crash Attenuator Systems and Bridge Rail, on a call-out basis in the Sabine County Maintenance Section.

TXDOT PROJECT SUPERVISORS: All work on this contract will be scheduled and directed by the Maintenance Section Supervisor(s) listed below. Payment will be made on a monthly basis for work completed and accepted according to specifications. All payment requests should be directed to the following Maintenance Section Supervisor(s) listed below.

<u>COUNTY</u>	<u>SUPERVISOR</u>	<u>ADDRESS</u>	<u>CONTACT #</u>
SABINE	Kenneth L Courville	300 FM 83 Hemphill, TX 75948	(409) 787-1751

CONTRACT PROSECUTION:

Each contract awarded by the Department stands on its own and, as such, is separate from other contracts. A Contractor awarded multiple contracts must be capable and sufficiently staffed to concurrently process any or all contracts at the same time.

There is a potential for work to be done in environmentally sensitive areas within these maintenance sections. All work shall be performed as directed by the Maintenance Section Supervisor to avoid impacts to these areas.

Several roadways in Sabine County are located on property owned by the US Forest Service (USFS). The Maintenance Section Office will notify the appropriate USFS District Ranger before any work begins on any roadway that is located on USFS property.

Minimize vehicles and equipment in construction areas to lessen the impact on existing vegetation. The intent of the plans is to prepare only that portion of the right-of-way necessary for construction.

Contractor questions on this project are to be addressed to the following individual(s):

Jeremy King Jeremy.King@TxDOT.gov
 Tamara Gibson Tamara.Gibson@TxDOT.gov

Questions may be submitted via the Letting Pre-Bid Q&A web page. This webpage can be accessed from the Notice to Contractors dashboard located at the following Address:

<https://tableau.txdot.gov/views/ProjectInformationDashboard/NoticetoContractors>

All contractor questions will be reviewed by the Engineer. All questions and any corresponding responses that are generated will be posted through the same Letting Pre-Bid Q&A web page. The Letting Pre-Bid Q&A web page for each project can be accessed by using the dashboard to navigate to the project you are interested in by scrolling or filtering the dashboard using the

Project Number: RMC 6422-70-001**Control: 6442-70-001****County: SABINE****Highway: US 96, ETC.**

controls on the left. Hover over the blue hyperlink for the project you want to view the Q&A for and click on the link in the window that pops up.

In case of emergency, the contractor shall begin work within 48 hours after verbal notification.

All workers on TxDOT right-of-way shall wear reflective clothing meeting ANSI Class II requirements during the day and ANSI Class III requirements during the night. Non-compliance with any of these requirements shall be grounds for suspension of work.

The following standard detail sheets have been modified; T202TR & T2/T201TR.

Item 2: Instructions to Bidders

View plans on-line or download from the web at:

http://www.txdot.gov/business/contractors_consultants/plans_online.htm

Order plans from any of the plan reproduction companies shown on the web at:

http://www.txdot.gov/business/contractors_consultants/repro_companies.htm

Item 4: Scope of Work

The contract may be extended if in the judgment of the Engineer, the Contractor has satisfactorily fulfilled the terms and conditions of the contract. The extension must be agreed upon in writing by both parties to the contract and may be extended for an additional period not to exceed the original contract period. The extended contract may be for additional quantities up to the original bid quantities plus any quantities added by an approved change order. The extensions will meet the terms and conditions of the original contract or any mutually agreed modifications to the said terms and conditions by one or more cumulative change orders. The Engineer will set a deadline for completing the agreements. This deadline will be based on the time needed to re-let and award a new contract if no extension is agreed upon.

Item 5: Control of the Work

The Contractor shall become knowledgeable of the location of utilities within the right-of-way and shall use

Item 7: Legal Relations and Responsibilities

The proposed work of this project is to repair damaged guard fence, attenuator, and metal rail within the Sabine County Maintenance Section on State right-of-way that may affect the safety of the traveling public. This activity maintains the original line and grade, hydraulic capacity, and original purpose of the site. Therefore, this project meets the definition of a routine maintenance activity as defined in the TPDES General Permit No. TXR150000 issued March 5, 2023, and TCEQ's TPDES CGP does not apply.

Project Number: RMC 6422-70-001**Control: 6442-70-001****County: SABINE****Highway: US 96, ETC.**

Red-cockaded Woodpecker (federally listed endangered species) habitat is present adjacent to the ROW along SH 87, FM 2426, and FM 2343. Conservation measures have been agreed upon by the United States Fish and Wildlife Service and TxDOT to ensure that the proposed action will not adversely affect the red-cockaded woodpecker. The conservation measures below must be followed to be in compliance with the Endangered Species Act.

NO WORK shall be performed at the below roadway limits from April 1 to July 31.

Work shall begin one hour after sunrise and cease one hour before sunset.

NO STOCKPILES or EQUIPMENT STORAGE shall be allowed along the below roadway limits. - On SH 87 from 0.75 miles South of FM 3315 to the Newton County line - On FM 2426 from 2.8 miles East of FM 1 to 8.1 miles east of FM 1 - On FM 2343 from 1.5 miles South of SH 87 to 2.15 miles south of SH 87

Texas golden glade cress (federally listed endangered species) critical habitat is present within the ROW along SH 21. The conservation measure below must be followed to be in compliance with the Endangered Species Act:

NO STOCKPILING or EQUIPMENT storage shall be allowed within the ROW along SH 21 at below roadway limits

NO EQUIPMENT or VEHICLES shall leave the pavement within the below roadway limits:

- SH 21 from 0.57 miles East of FM 330 to 1.63 miles East of FM 330

Portions of State Highway (SH) SH 21, SH 87, Farm-to-Market (FM) 330, FM 242, FM 3121, FM 83, FM 3382, FM 3520, FM 1368, FM 944, FM 2971, FM 2426, FM 2928, FM 2343 and FM 201 in Sabine County pass through compartments of the Sabine National Forest. The following actions are required:

Maintenance Supervisor shall notify Sabine National Forest (USFS) prior to commencing work on the above listed roadways within the USFS boundaries.

NO stockpiling or storage of materials and equipment within USFS boundaries.

Contractor to repair or replace in kind, at their own expense, any historic materials damaged (buildings, historical markers, etc.) while executing the work. Contractor is responsible for locating replacement source for historic materials damaged in the course of the work. TxDOT Environmental Affairs Division is to be informed of proposed repairs to facilitate consultation with Texas Historical Commission prior to execution of repairs. Care when working near them.

Item 7: Legal Relations and Responsibilities

The proposed work of this project is to repair damaged guard fence, attenuator, and metal rail within the Sabine County Maintenance Section on State right-of-way that may affect the safety of the traveling public. This activity maintains the original line and grade, hydraulic capacity, and original purpose of the site. Therefore, this project meets the definition of a routine

General Notes**Sheet 3A****Project Number: RMC 6422-70-001****Control: 6442-70-001****County: SABINE****Highway: US 96, ETC.**

maintenance activity as defined in the TPDES General Permit No. TXR150000 issued March 5, 2023, and TCEQ's TPDES CGP does not apply.

Dispose of all vegetative matter and any other materials removed from State Right of Way in accordance with applicable environmental laws, rules, regulations, and requirements.

Red-cockaded Woodpecker (federally listed endangered species) habitat is present adjacent to the ROW along SH 87, FM 2426, and FM 2343. Conservation measures have been agreed upon by the United States Fish and Wildlife Service and TxDOT to ensure that the proposed action will not adversely affect the red-cockaded woodpecker. The conservation measures below must be followed to be in compliance with the Endangered Species Act. NO WORK shall be performed at the below roadway limits from April 1 to July 31.

Work shall begin one hour after sunrise and cease one hour before sunset.

NO STOCKPILES or EQUIPMENT STORAGE shall be allowed along the below roadway limits.

- On SH 87 from 0.75 miles South of FM 3315 to the Newton County line
- On FM 2426 from 2.8 miles East of FM 1 to 8.1 miles east of FM 1
- On FM 2343 from 1.5 miles South of SH 87 to 2.15 miles south of SH 8

Texas golden glade cress (federally listed endangered species) critical habitat is present within the ROW along SH 21. The conservation measure below must be followed to be in compliance with the Endangered Species Act: NO STOCKPILING or EQUIPMENT storage shall be allowed within the ROW along SH 21 at below roadway limits
NO EQUIPMENT or VEHICLES shall leave the pavement within the below roadway limits

- SH 21 from 0.57 miles East of FM 330 to 1.63 miles East of FM 330

Portions of State Highway (SH) SH 21, SH 87, Farm-to-Market (FM) 330, FM 242, FM 3121, FM 83, FM 3382, FM 3520, FM 1368, FM 944, FM 2971, FM 2426, FM 2928, FM 2343, and FM 201 in Sabine County pass through compartments of the Sabine National Forest. The following actions are required:

Maintenance Supervisor shall notify Sabine National Forest (USFS) prior to commencing work on the above listed roadways within the USFS boundaries.

NO stockpiling or storage of materials and equipment within USFS boundaries.

Contractor to repair or replace in kind, at their own expense, any historic materials damaged (buildings, historical markers, etc.) while executing the work. Contractor is responsible for locating replacement source for historic materials damaged in the course of the work. TxDOT Environmental Affairs Division is to be informed of proposed repairs to facilitate consultation with Texas Historical Commission prior to execution of repairs.

General Notes**Sheet 3A**

Project Number: RMC 6422-70-001**Control: 6442-70-001****County: SABINE****Highway: US 96, ETC.****Item 8: Prosecution and Progress**

Contract Time: This project shall be 365 days or 1 year after the execution of this contract.

For this project, working days will be computed and charged in accordance with Item 8, Section 3.1.5, "Calendar Day".

This contract includes callout work; the number of working days will be established in each work order.

The Engineer will specify the number of working days granted for each work order based on a percentage of the dollar amount of the work order versus the total dollar amount of the contract or based on typical production rates for the work ordered.

The Contractor shall be on site within 48 hours for emergency work orders or within five business days for regular work orders.

Verbal notification may be given for the work orders above, however, written notification will be delivered electronically following the verbal notification. Written notification will state the date of verbal approval to begin work.

Notify the Engineer at least 24 hours before proceeding with planned work activities to the requesting Maintenance Section or appropriate contact person. Any work performed without proper notification will not be eligible for payment.

Perform work only as directed by a work order. Any work performed at locations not covered by a work order will not be paid for, unless directly authorized.

In accordance with Article 8.6 "Failure to Complete the Work on Time", liquidated damages will be charged for failure to complete each work order in the specified number of days. The Liquidated Damage amount to be assessed per day, until the work is completed will be 1% of the estimated cost of the Work Order, but not less than \$50 per day and not to exceed \$200 per day

Item 9: Measurement and Payment

This Contract includes callout work. In accordance with Article 9.2., "Plans Quantity Measurement", plans quantity measurement requirements are not applicable. The quantities shown are for estimates only and payment will be based on the actual quantities placed.

NONCOMPLIANCE PENALTY – A penalty will be assessed for each instance the contractor is in noncompliance. A noncompliance instance is defined by the following:

- The contractor fails to begin work at the specified time and/or location(s).

General Notes**Sheet 3B****Project Number: RMC 6422-70-001****Control: 6442-70-001****County: SABINE****Highway: US 96, ETC.**

- The contractor does not have all the personnel and pieces of equipment necessary to fulfill the requirement of the item(s) called out at the specified time and/or location(s)
- The contractor does not complete the work continuously, unless approved by the Engineer.

The Noncompliance penalty will be deducted from any money due or to become due for any completed item(s) or work. The Noncompliance Penalty will be assessed as follows: \$250 per instance, per location, and per day until the contractor returns to a state of compliance.

Item 502: Barricades, Signs, and Traffic Handling

Traffic Control Plan (TCP):

Furnish and maintain all warning signs, flaggers, channelizing devices, etc. required for traffic control on this contract in accordance with Item 502.1 & 502.2. This work will not be paid for directly but will be considered subsidiary to the various bid items.

For protection of the traveling public, direct traffic through the work area using signs, flaggers, and other devices. Required signs are shown in the plans on the Barricade and Construction Standards and Traffic Control Plan Sheets. The latest edition of the "Texas Manual on Uniform Traffic Control Devices" shall also be used as a guide for handling traffic on this project.

Texas Transportation Code 547.105 authorizes the use of warning lights to promote safety and provides an effective means of gaining the travelling public's attention as they drive in areas where construction crews are present. To influence the public to move over when high risk construction activities are taking place, minimize the utilization of blue warning lights. These lights must be used only while performing work on or near the travel lanes or shoulder where the travelling public encounters construction crews that are not protected by a standard work zone set up such as a lane closure, shoulder closure, or one-way traffic control. Refrain from leaving the warning lights engaged while travelling from one work location to another or while parked on State right-of-way away from the pavement or a work zone.

Restrict construction work to single lane widths with only minor disruptions in traffic flow. Lane closures shall conform to the traffic control plan for lane closures as shown in the plans. No overnight closures will be permitted.

Provide temporary Rumble Strips as shown on Work Zone standards when lane closures are necessary.

Provide a flashing arrow panel and a truck-mounted attenuator to supplement required signs and devices for each lane closure.

Provide adequate flaggers to protect the traveling public. All flaggers shall wear approved hardhats and reflective safety vests while flagging. Safety vests shall be clean and worn fully fastened.

General Notes**Sheet 3B**

Project Number: RMC 6422-70-001

Control: 6442-70-001

County: SABINE

Highway: US 96, ETC.

Install “Be Prepared to Stop” (CW20-7B) and “Flagger Ahead” (CW22-7D) signs when flaggers are present. Position the signs where good visibility and traffic control can be maintained.

Provide one high-intensity yellow, rotating dome-light on all equipment such as distributors, spreader boxes, lay-down machines, rollers, backhoes, road graders, loaders, etc. Mount lights high enough to be visible from all directions and operating when the equipment is within 30 ft. of the travel way. On all other equipment such as trucks, trailers, automobiles, etc., use emergency flashers while within the work zone.

No lane closures will be allowed after 12:00 Noon on Fridays or on days preceding Major Holidays on US 96, SH 21, and SH 103, unless otherwise directed.

Plan the sequence of work to minimize the time lane closures are in place.

All traffic control for this project, apart from Truck Mounted Attenuators (TMA’s), shall be subsidiary to the various bid items.

Item 540: Metal Beam Guard Fence & Item 770: Guard Fence Repair

GF (31)-19, GF(31)TRTL2-19, GF(31)TRTL3-20, SGT(10S)31-16, SGT(11S)31-18, SGT(12S)31-18, MBGF-19 & BED-14 standards shall be used on upgrades unless otherwise directed by the Engineer.

All materials removed and deemed salvageable by the maintenance section supervisor shall be hauled to and neatly stockpiled at the Sabine County Maintenance Section yard at 300 FM 83 in Hemphill. All non-salvageable materials shall become the property of the Contractor.

All materials furnished by the Contractor shall be new.

Existing concrete that will conflict with installing the new system shall be completely removed and disposed of by the Contractor. This work will not be paid for directly but shall be considered subsidiary to removal of the existing guardrail terminal.

Timber posts shall be domed. When posts are placed, new posts shall match the existing post such that each is uniform in height.

At the close of work each day, if repairs are not complete, the Contractor shall protect the ends of metal beam guard fence in an approved manner, so that no blunt ends are exposed to approaching traffic. Plastic drums will be required at these locations. This work will be subsidiary to the work performed under Item 540, Metal Beam Guard Fence (MBGF) or Item 770, Guard Fence Repair.

Completely clean the area of all debris including debris left from reconstruction of the Guardrail or Bridge Rail assembly as well as any litter created by the crew. Remove or spread surplus soil and material that has collected under the rail to the natural grade of the surrounding area.

General Notes

Sheet 3C

Project Number: RMC 6422-70-001

Control: 6442-70-001

County: SABINE

Highway: US 96, ETC.

Item 658: Delineator and Object Marker Assemblies

Install delineators on the departure side of block outs when mounting to metal beam guard fence and guardrail end treatments.

Install CTB barrier reflectors on top of concrete bridge rail and concrete barriers.

Install D-SW delineators on the departure side of steel bridge rail posts.

Item 774: Attenuator Repair

The contractor shall furnish details on the method proposed to “Retrofit” the new systems at the existing crash cushion locations, prior to beginning this work. FASTER Systems will be furnished by TxDOT.

Item 6185: Truck Mounted Attenuator (TMA) and Trailer Attenuator (TA)

Truck Mounted Attenuators (TMA’s) shall meet the requirements of this item and the Department’s Compliant Work Zone Traffic Control Device List.

Truck Mounted Attenuators (TMA’s) as shown on the TCP’s shall be used. Whether shown on the TCP’s or added by the Department, TMAs shall be paid for under Item 6185, “Truck Mounted Attenuator” for the type of operation being performed.

General Notes

Sheet 3C



Estimate & Quantity Sheet

CONTROLLING PROJECT ID 6442-70-001

DISTRICT Lufkin
HIGHWAY US0096

COUNTY Sabine

CONTROL SECTION JOB				6442-70-001		TOTAL EST.	TOTAL FINAL
PROJECT ID				A00196600			
COUNTY				Sabine			
HIGHWAY				US0096			
ALT	BID CODE	DESCRIPTION	UNIT	EST.	FINAL		
	104-6021	REMOVING CONC (CURB)	LF	60.000		60.000	
	429-6007	CONC STR REPAIR (VERTICAL & OVERHEAD)	SF	100.000		100.000	
	429-6009	CONC STR REPAIR (STANDARD)	SF	15.000		15.000	
	450-6018	RAIL (TY T631)	LF	30.000		30.000	
	450-6019	RAIL (TY T631LS)	LF	20.000		20.000	
	500-6033	MOBILIZATION (CALLOUT)	EA	10.000		10.000	
	540-6001	MTL W-BEAM GD FEN (TIM POST)	LF	400.000		400.000	
	540-6005	TERMINAL ANCHOR SECTION	EA	4.000		4.000	
	540-6006	MTL BEAM GD FEN TRANS (THRIE-BEAM)	EA	2.000		2.000	
	540-6008	MTL BEAM GD FEN TRANS (T101)	EA	4.000		4.000	
	540-6014	SHORT RADIUS	LF	50.000		50.000	
	540-6015	DRIVEWAY TERMINAL ANCHOR SECTION	EA	2.000		2.000	
	540-6016	DOWNSTREAM ANCHOR TERMINAL SECTION	EA	4.000		4.000	
	540-6017	MTL BM GD FEN (LONG SPAN SYSTEM)	LF	65.000		65.000	
	540-6018	MTL BM GD FEN TRANS (NON - SYM)	EA	8.000		8.000	
	540-6020	MTL W - BEAM GD FEN (LOW FILL CULVERT)	LF	35.000		35.000	
	542-6001	REMOVE METAL BEAM GUARD FENCE	LF	4,000.000		4,000.000	
	542-6002	REMOVE TERMINAL ANCHOR SECTION	EA	3.000		3.000	
	542-6003	REMOVE DOWNSTREAM ANCHOR TERMINAL	EA	20.000		20.000	
	542-6004	RM MTL BM GD FENCE TRANS (THRIE-BEAM)	EA	6.000		6.000	
	544-6001	GUARDRAIL END TREATMENT (INSTALL)	EA	6.000		6.000	
	544-6002	GUARDRAIL END TREATMENT (MOVE & RESET)	EA	6.000		6.000	
	544-6006	GDRAIL END TRT(INST)(WOOD POST)(TY III)	EA	6.000		6.000	
	658-6016	INSTL DEL ASSM (D-SW)SZ (BRF)GF1 (BI)	EA	10.000		10.000	
	658-6099	INSTL OM ASSM (OM-2Z)(WFLX)GND	EA	10.000		10.000	
	770-6001	REPAIR RAIL ELEMENT (W - BEAM)	LF	600.000		600.000	
	770-6003	REP RAIL ELMNT(THRIE-BM TRANS TO W -BM)	LF	25.000		25.000	
	770-6010	REM / REPL TIMBER/STL POST W/O CONC FND	EA	40.000		40.000	
	770-6011	REM / REPL TIMBER / STL POST W/CONC FND	EA	15.000		15.000	
	770-6016	REPAIR STEEL POST WITH BASE PLATE	EA	5.000		5.000	
	770-6017	REALIGN POSTS	EA	20.000		20.000	
	770-6018	INSTALL BLOCKOUT (TYPE SPECIFIED)	EA	20.000		20.000	
	770-6019	REMOVE & REPLACE BLOCKOUT	EA	5.000		5.000	
	770-6021	REPLACE SINGLE GDRAIL TERMINAL RAIL	LF	75.000		75.000	
	770-6022	REPLACE SINGLE GDRAIL TERMINAL POST	EA	15.000		15.000	
	770-6023	REPAIR OF TERMINAL ANCHORS POSTS	EA	20.000		20.000	
	770-6024	REPLACE TERMINAL ANCHOR POSTS	EA	20.000		20.000	



DISTRICT	COUNTY	CCSJ	SHEET
Lufkin	Sabine	6442-70-001	4



Estimate & Quantity Sheet

CONTROLLING PROJECT ID 6442-70-001

DISTRICT Lufkin
HIGHWAY US0096

COUNTY Sabine

CONTROL SECTION JOB				6442-70-001		TOTAL EST.	TOTAL FINAL
PROJECT ID				A00196600			
COUNTY				Sabine			
HIGHWAY				US0096			
ALT	BID CODE	DESCRIPTION	UNIT	EST.	FINAL		
	770-6027	REMOVE GDRAIL END TRT / REPL WITH SGT	EA	3.000		3.000	
	770-6028	REPL SINGLE GDRAIL TERM IMPACT HEAD	EA	4.000		4.000	
	770-6029	REM & RESET SGT IMPACT HEAD	EA	4.000		4.000	
	770-6030	REPLACE SGT CABLE ASSEMBLY	EA	5.000		5.000	
	770-6031	REPLACE SGT CABLE ANCHOR	EA	5.000		5.000	
	770-6032	REPLACE SGT STRUT	EA	5.000		5.000	
	770-6033	REPLACE SGT OBJECT MARKER	EA	5.000		5.000	
	770-6034	REPAIR RAIL ELEMENT(W - BEAM FURNISHED)	LF	50.000		50.000	
	774-6017	REPAIR (WIDE QUAD)	EA	2.000		2.000	
	776-6004	REPAIR (STL POST W/ DOUBLED W-BEAMS-T6)	LF	25.000		25.000	
	776-6020	REPAIR (TY T101RC)	LF	25.000		25.000	
	6185-6002	TMA (STATIONARY)	DAY	10.000		10.000	

DISTRICT	COUNTY	CCSJ	SHEET
Lufkin	Sabine	6442-70-001	4A

4/12/2023 8:53:47 AM T:\LF\KDM\Main\Print\contracts\O-RMC - Rout\ne Maintenance Contracts\FY23 Plans\6442-70-001 Sob\ne MBGF\DGN\OSUM_Sob\ne MBGF_6341-09-001.dgn

SUMMARY OF GUARD FENCE, ATTENUATOR & RAIL REPAIR			
BID ITEM	DESCRIPTION	UNIT	QUANTITY
0104-6021	REMOVING CONC (CURB)	LF	60
0429-6007	CONC STR REPAIR (VERTICAL & OVERHEAD)	SF	100
0429-6009	CONC STR REPAIR (STANDARD)	SF	15
0450-6018	RAIL (TY T631)	LF	30
0450-6019	RAIL (TY T631LS)	LF	20
0540-6001	MTL W-BEAM GD FEN (TIM POST)	LF	400
0540-6005	TERMINAL ANCHOR SECTION	EA	4
0540-6006	MTL BEAM GD FEN TRANS (THRIE-BEAM)	EA	2
0540-6008	MTL BEAM GD FEN TRANS (T101)	EA	4
0540-6014	SHORT RADIUS	LF	50
0540-6015	DRIVEWAY TERMINAL ANCHOR SECTION	EA	2
0540-6016	DOWNSTREAM ANCHOR TERMINAL SECTION	EA	4
0540-6017	MTL BM GD FEN (LONG SPAN SYSTEM)	LF	65
0540-6018	MTL BM GD FEN TRANS (NON - SYM)	EA	8
0540-6020	MTL W - BEAM GD FEN (LOW FILL CULVERT)	LF	35
0542-6001	REMOVE METAL BEAM GUARD FENCE	LF	4000
0542-6002	REMOVE TERMINAL ANCHOR SECTION	EA	3
0542-6003	REMOVE DOWNSTREAM ANCHOR TERMINAL	LF	20
0542-6004	RM MTL BM GD FENCE TRANS (THRIE-BEAM)	EA	6
0544-6001	GUARDRAIL END TREATMENT (INSTL)	EA	6
0544-6002	GUARDRAIL END TREATMENT (MOVE & RESET)	EA	6
0544-6006	GDRAIL END TRT (INST) (WOOD POST) (TY III)	EA	6
0658-6016	INSTL DEL ASSM (D-SW)SZ (BRF)GF1 (BI)	EA	10
0658-6099	INSTL OM ASSM (OM-2Z) (WFLX)GND	EA	10
0770-6001	REPAIR RAIL ELEMENT (W - BEAM)	LF	600
0770-6003	REP RAIL ELMNT (THRIE-BM TRANS TO W - BM)	LF	25
0770-6010	REM / REPL TIMBER / STL POST W/O CONC FND	EA	40
0770-6011	REM / REPL TIMBER / STL POST W/CONC FND	EA	15
0770-6016	REPAIR STEEL POST WITH BASE PLATE	EA	5
0770-6017	REALIGN POSTS	EA	20
0770-6018	INSTALL BLOCKOUT (TYPE SPECIFIED)	EA	20
0770-6019	REMOVE & REPLACE BLOCKOUT	EA	5
0770-6021	REPLACE SINGLE GDRAIL TERMINAL RAIL	LF	75
0770-6022	REPLACE SINGLE GDRAIL TERMINAL POST	EA	15
0770-6023	REPAIR OF TERMINAL ANCHORS POSTS	EA	20
0770-6024	REPLACE TERMINAL ANCHOR POSTS	EA	20
0770-6027	REMOVE GDRAIL END TRT / REPL WITH SGT	EA	3
0770-6028	REPL SINGLE GDRAIL TERM IMPACT HEAD	EA	4
0770-6029	REM & RESET SGT IMPACT HEAD	EA	4
0770-6030	REPLACE SGT CABLE ASSEMBLY	EA	5
0770-6031	REPLACE SGT CABLE ANCHOR	EA	5
0770-6032	REPLACE SGT STRUT	EA	5
0770-6033	REPLACE SGT OBJECT MARKER	EA	5
0770-6034	REPAIR RAIL ELEMENT (W - BEAM FURNISHED)	LF	50
0774-6017	REPAIR (WIDE QUAD)	EA	2
0776-6004	REPAIR (STL POST W / DOUBLE W - BEAMS - T6)	LF	25
0776-6020	REPAIR (TY T101RC)	LF	25

1 WHEN ATTACHING THRIE BEAM TO T202, T2 OR T201 RAILS, ANCHOR PLATES AS SHOWN ON DETAILS T202 TR & T2/T201 TR WILL BE CONSIDERED SUBSIDIARY TO THE THRIE-BEAM SYSTEM.

TRUCK MOUNTED ATTENUATOR SUMMARY			
BID ITEM	DESCRIPTION	UNIT	QUANTITY
6185-6001	TMA (STATIONARY)	DAY	10

QUANTITY SUMMARY

©2023 Texas Department of Transportation

CONT	SECT	JOB	HIGHWAY
6442	70	001	US 96, ETC.
DIST	COUNTY	SHEET NO.	
LFK	SABINE	5	

DISCLAIMER: The use of this standard is governed by the "Texas Engineering Practice Act". No warranty of any kind is made by the Texas Department of Transportation for the use of this standard for any other purpose, or for any other project, or for any other use. The user assumes all liability for any damage resulting from its use.

DATE: 4/12/2023 7:22:41 AM
 FILE: T:\LKDD\MAINT\Contracts\00.RMC - Routine Maintenance Contracts\rv23 Plans\6442-70-001\Subline\BARR-CON-STDNSC-21.dgn

BARRICADE AND CONSTRUCTION (BC) STANDARD SHEETS GENERAL NOTES:

- The Barricade and Construction Standard Sheets (BC sheets) are intended to show typical examples for placement of temporary traffic control devices, construction pavement markings, and typical work zone signs. The information contained in these sheets meet or exceed the requirements shown in the "Texas Manual on Uniform Traffic Control Devices" (TMUTCD).
- The development and design of the Traffic Control Plan (TCP) is the responsibility of the Engineer.
- The Contractor may propose changes to the TCP that are signed and sealed by a licensed professional engineer for approval. The Engineer may develop, sign and seal Contractor proposed changes.
- The Contractor is responsible for installing and maintaining the traffic control devices as shown in the plans. The Contractor may not move or change the approximate location of any device without the approval of the Engineer.
- Geometric design of lane shifts and detours should, when possible, meet the applicable design criteria contained in manuals such as the American Association of State Highway and Transportation Officials (AASHTO), "A Policy on Geometric Design of Highways and Streets," the TxDOT "Roadway Design Manual" or engineering judgment.
- When projects abut, the Engineer(s) may omit the END ROAD WORK, TRAFFIC FINES DOUBLE, and other advance warning signs if the signing would be redundant and the work areas appear continuous to the motorists. If the adjacent project is completed first, the Contractor shall erect the necessary warning signs as shown on these sheets, the TCP sheets or as directed by the Engineer. The BEGIN ROAD WORK NEXT X MILES sign shall be revised to show appropriate work zone distance.
- The Engineer may require duplicate warning signs on the median side of divided highways where median width will permit and traffic volumes justify the signing.
- All signs shall be constructed in accordance with the details found in the "Standard Highway Sign Designs for Texas," latest edition. Sign details not shown in this manual shall be shown in the plans or the Engineer shall provide a detail to the Contractor before the sign is manufactured.
- The temporary traffic control devices shown in the illustrations of the BC sheets are examples. As necessary, the Engineer will determine the most appropriate traffic control devices to be used.
- Where highway construction or maintenance work is being undertaken, other than mobile operations as defined by the Texas Manual on Uniform Traffic Control Devices, CSJ limit signs are required. CSJ limit signs are shown on BC(2). The OBEY WARNING SIGNS STATE LAW sign, STAY ALERT TALK OR TEXT LATER and the WORK ZONE TRAFFIC FINES DOUBLE sign with plaque shall be erected in advance of the CSJ limits. The BEGIN ROAD WORK NEXT X MILES, CONTRACTOR and END ROAD WORK signs shall be erected at or near the CSJ limits. For mobile operations, CSJ limit signs are not required.
- Traffic control devices should be in place only while work is actually in progress or a definite need exists.
- The Engineer has the final decision on the location of all traffic control devices.
- Inactive equipment and work vehicles, including workers' private vehicles must be parked away from travel lanes. They should be as close to the right-of-way line as possible, or located behind a barrier or guardrail, or as approved by the Engineer.

WORKER SAFETY NOTES:

- Workers on foot who are exposed to traffic or to construction equipment within the right-of-way shall wear high-visibility safety apparel meeting the requirements of ISEA "American National Standard for High-Visibility Apparel," or equivalent revisions, and labeled as ANSI 107-2004 standard performance for Class 2 or 3 risk exposure. Class 3 garments should be considered for high traffic volume work areas or night time work.
- Except in emergency situations, flagger stations shall be illuminated when flagging is used at night.

COMPLIANT WORKZONE TRAFFIC CONTROL DEVICES

- Only pre-qualified products shall be used. The "Compliant Work Zone Traffic Control Devices List" (CWZTCD) describes pre-qualified products and their sources.
- Work zone traffic control devices shall be compliant with the Manual for Assessing safety Hardware (MASH).

THE DOCUMENTS BELOW CAN BE FOUND ON-LINE AT http://www.txdot.gov
COMPLIANT WORK ZONE TRAFFIC CONTROL DEVICES LIST (CWZTCD)
DEPARTMENTAL MATERIAL SPECIFICATIONS (DMS)
MATERIAL PRODUCER LIST (MPL)
ROADWAY DESIGN MANUAL - SEE "MANUALS (ONLINE MANUALS)"
STANDARD HIGHWAY SIGN DESIGNS FOR TEXAS (SHSD)
TEXAS MANUAL ON UNIFORM TRAFFIC CONTROL DEVICES (TMUTCD)
TRAFFIC ENGINEERING STANDARD SHEETS

SHEET 1 OF 12

 Texas Department of Transportation		Traffic Safety Division Standard	
BARRICADE AND CONSTRUCTION GENERAL NOTES AND REQUIREMENTS			
BC(1) - 21			
FILE:	bc-21.dgn	DN:	TxDOT
CONT:	6442	SECT:	70
REV:	NOVEMBER 2002	JOB:	001
DATE:	4-03	DIST:	US 96, ETC.
	7-13	COUNTY:	
	9-07	SHEET NO.:	6
	8-14		
	5-10		
	5-21		

TYPICAL LOCATION OF CROSSROAD SIGNS

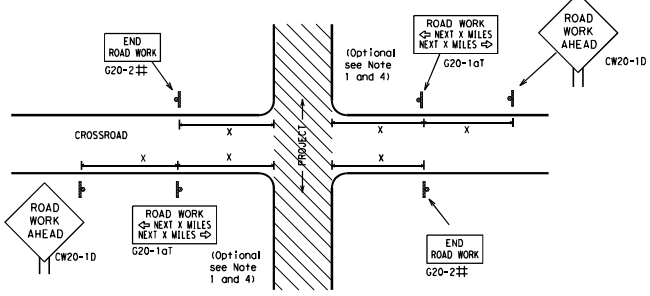

May be mounted on back of "ROAD WORK AHEAD" (CW20-1D) sign with approval of Engineer. (See note 2 below)

- The typical minimum signing on a crossroad approach should be a "ROAD WORK AHEAD" (CW20-1D) sign and a (G20-2) "END ROAD WORK" sign, unless noted otherwise in plans.
- The Engineer may use the reduced size 36" x 36" ROAD WORK AHEAD (CW20-1D) sign mounted back to back with the reduced size 36" x 18" "END ROAD WORK" (G20-2) sign on low volume crossroads (see Note 4 under "Typical Construction Warning Sign Size and Spacing"). See the "Standard Highway Sign Designs for Texas" manual for sign details. The Engineer may omit the advance warning signs on low volume crossroads. The Engineer will determine whether a road is low volume as per TMUTCD Part 5. This information shall be shown in the plans.
- Based on existing field conditions, the Engineer/Inspector may require additional signs such as FLAGGER AHEAD, LOOSE GRAVEL, or other appropriate signs. When additional signs are required, these signs will be considered part of the minimum requirements. The Engineer/Inspector will determine the proper location and spacing of any sign not shown on the BC sheets, Traffic Control Plan sheets or the Work Zone Standard Sheets.
- The "ROAD WORK NEXT X MILES" (G20-1aT) sign shall be required at high volume crossroads to advise motorists of the length of construction in either direction from the intersection. The Engineer will determine whether a roadway is considered high volume.
- Additional traffic control devices may be shown elsewhere in the plans for higher volume crossroads.
- When work occurs in the intersection area, appropriate traffic control devices, as shown elsewhere in the plans or as determined by the Engineer/Inspector, shall be in place.

T-INTERSECTION

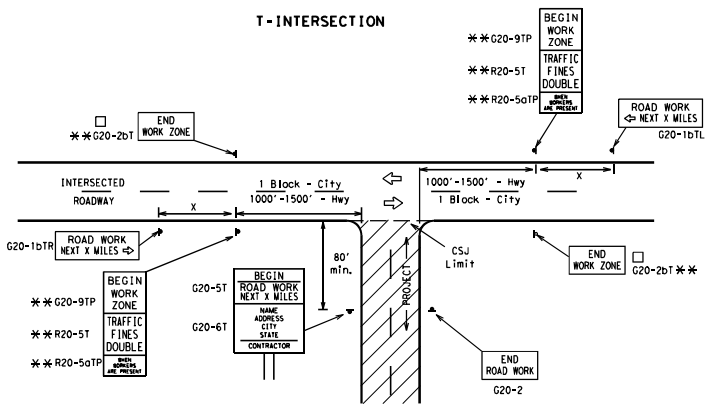

CSJ LIMITS AT T-INTERSECTION

- The Engineer will determine the types and location of any additional traffic control devices, such as a flagger and accompanying signs, or other signs, that should be used when work is being performed at or near an intersection.
- If construction closes the road at a T-intersection, the Contractor shall place the "CONTRACTOR NAME" (G20-6T) sign behind the Type 3 Barricades for the road closure (see BC(10) also). The "ROAD WORK NEXT X MILES" left arrow (G20-1bTL) and "ROAD WORK NEXT X MILES" right arrow (G20-1bTR) signs shall be replaced by the detour signing called for in the plans.

TYPICAL CONSTRUCTION WARNING SIGN SIZE AND SPACING^{15.6}

Sign Number or Series	SIZE		SPACING	
	Conventional Road	Expressway/Freeway	Posted Speed	Sign Δ Spacing "X"
CW20 ⁴	48" x 48"	48" x 48"	MPH	Feet (Approx.)
CW21			30	120
CW22			35	160
CW23			40	240
CW25			45	320
CW1, CW2, CW7, CW8, CW9, CW11, CW14	36" x 36"	48" x 48"	50	400
			55	500 ²
			60	600 ²
			65	700 ²
			70	800 ²
CW3, CW4, CW5, CW6, CW8-3, CW10, CW12	48" x 48"	48" x 48"	75	900 ²
			80	1000 ²
			*	*
			*	* 3

* For typical sign spacings on divided highways, expressways and freeways, see Part 6 of the "Texas Manual on Uniform Traffic Control Devices" (TMUTCD) typical application diagrams or TCP Standard Sheets.

Δ Minimum distance from work area to first Advance Warning sign nearest the work area and/or distance between each additional sign.

GENERAL NOTES

- Special or larger size signs may be used as necessary.
- Distance between signs should be increased as required to have 1500 feet advance warning.
- Distance between signs should be increased as required to have 1/2 mile or more advance warning.
- 36" x 36" "ROAD WORK AHEAD" (CW20-1D) signs may be used on low volume crossroads at the discretion of the Engineer as per TMUTCD Part 5. See Note 2 under "Typical Location of Crossroad Signs".
- Only diamond shaped warning sign sizes are indicated.
- See sign size listing in "TMUTCD", Sign Appendix or the "Standard Highway Sign Designs for Texas" manual for complete list of available sign design sizes.

WORK AREAS IN MULTIPLE LOCATIONS WITHIN CSJ LIMITS

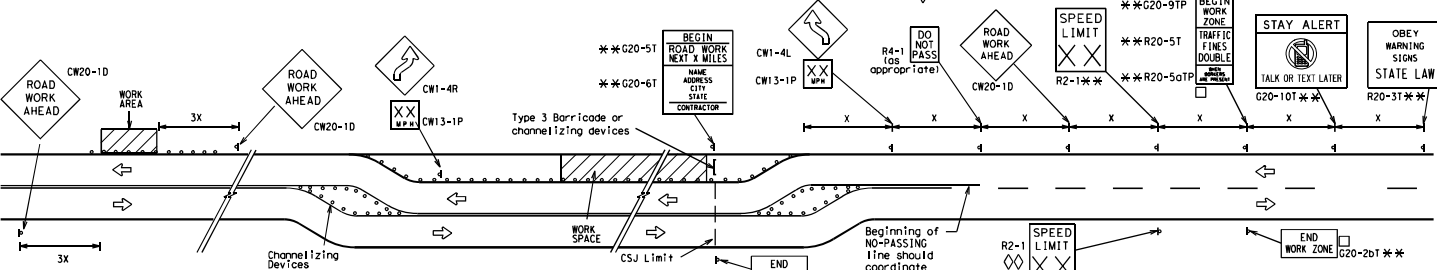

When extended distances occur between minimal work spaces, the Engineer/Inspector should ensure additional "ROAD WORK AHEAD" (CW20-1D) signs are placed in advance of these work areas to remind drivers they are still within the project limits. See the applicable TCP sheets for exact location and spacing of signs and channelizing devices.

SAMPLE LAYOUT OF SIGNING FOR WORK BEGINNING AT THE CSJ LIMITS

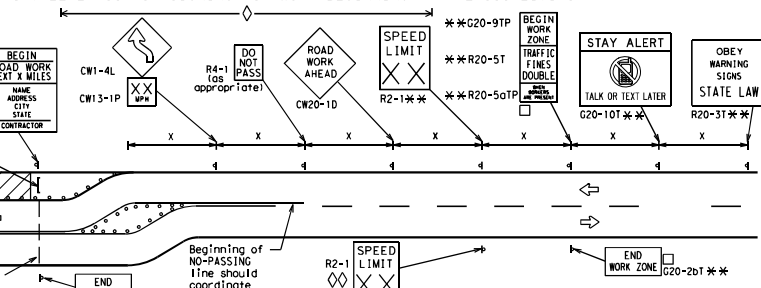

NOTES

- The Contractor shall determine the appropriate distance to be placed on the G20-1 series signs and "BEGIN ROAD WORK NEXT X MILES" (G20-5T) sign for each specific project. This distance shall replace the "X" and shall be rounded to the nearest whole mile with the approval of the Engineer. No decimals shall be used.
- The "BEGIN WORK ZONE" (G20-9TP) and "END WORK ZONE" (G20-2bT) shall be used as shown on the sample layout when advance signs are required outside the CSJ Limits. They inform the motorist of entering or leaving a part of the work zone lying outside the CSJ Limits where traffic fines may double if workers are present.
 - CSJ limit signing is required for highway construction and maintenance work, with the exception of mobile operations.
 - Area for placement of "ROAD WORK AHEAD" (CW20-1D) sign and other signs or devices as called for on the Traffic Control Plan.
 - Contractor will install a regulatory speed limit sign at the end of the work zone.

SAMPLE LAYOUT OF SIGNING FOR WORK BEGINNING DOWNSTREAM OF THE CSJ LIMITS

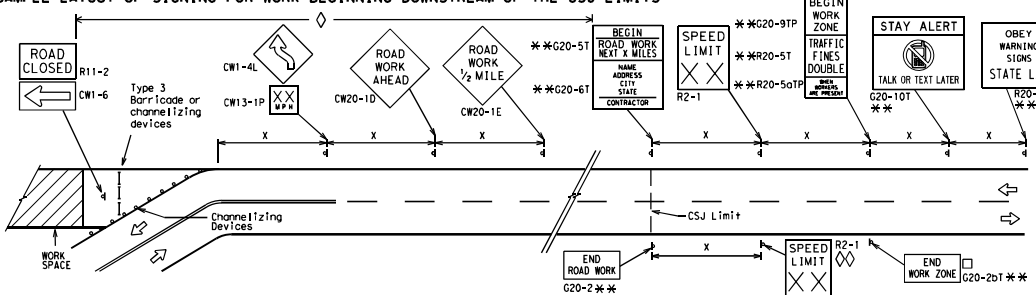

LEGEND	
	Type 3 Barricade
	Channelizing Devices
	Sign
X	See Typical Construction Warning Sign Size and Spacing chart or the TMUTCD for sign spacing requirements.

SHEET 2 OF 12

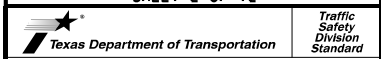

BARRICADE AND CONSTRUCTION PROJECT LIMIT

BC(2)-21

FILE: bc-21.dgn	DATE: TxDOT	DATE: TxDOT	DATE: TxDOT	DATE: TxDOT
REVISED: November 2002	CONT: 6442	SECT: 70	JOB: 001	HIGHWAY: US 96, ETC.
DATE: 9-07	DATE: 8-14	DATE: 7-13	DATE: 5-21	DATE: 7-13
FILE: LFK	DATE: SABINE	DATE:	DATE:	DATE:

DISCLAIMER: The use of this standard is governed by the "Texas Engineering Practice Act". No warranty of any kind is made by the State of Texas for the use of this standard. The user of this standard is responsible for the results of its use. The user of this standard is responsible for the results of its use. The user of this standard is responsible for the results of its use.

DATE: 4/12/2023 7:22:42 AM
 FILE: T:\LK\KDM\mnt\contracts\0-RMC - Routine Maintenance Contracts\123-123-001-001.dgn

TYPICAL APPLICATION OF WORK ZONE SPEED LIMIT SIGNS

Work zone speed limits shall be regulatory, established in accordance with the "Procedures for Establishing Speed Zones," and approved by the Texas Transportation Commission, or by City Ordinance when within Incorporated City Limits.

Reduced speeds should only be posted in the vicinity of work activity and not throughout the entire project. Regulatory work zone speed signs (R2-1) shall be removed or covered during periods when they are not needed.

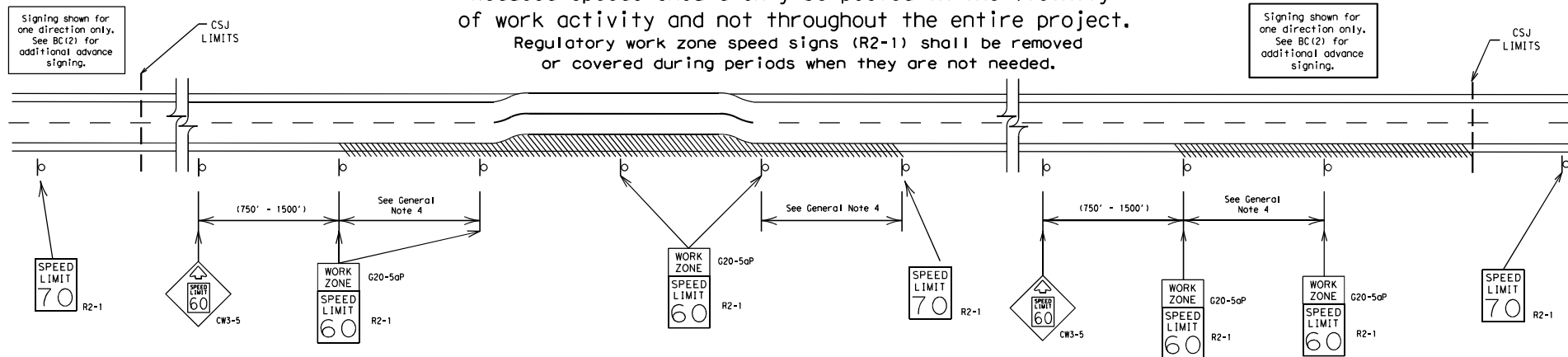

GUIDANCE FOR USE:

LONG/INTERMEDIATE TERM WORK ZONE SPEED LIMITS

This type of work zone speed limit should be included on the design of the traffic control plans when restricted geometrics with a lower design speed are present in the work zone and modification of the geometrics to a higher design speed is not feasible.

Long/Intermediate Term Work Zone Speed Limit signs, when approved as described above, should be posted and visible to the motorist when work activity is present. Work activity may also be defined as a change in the roadway that requires a reduced speed for motorists to safely negotiate the work area, including:

- a) rough road or damaged pavement surface
- b) substantial alteration of roadway geometrics (diversions)
- c) construction detours
- d) grade
- e) width
- f) other conditions readily apparent to the driver

As long as any of these conditions exist, the work zone speed limit signs should remain in place.

SHORT TERM WORK ZONE SPEED LIMITS

This type of work zone speed limit may be included on the design of the traffic control plans when workers or equipment are not behind concrete barrier, when work activity is within 10 feet of the traveled way or actually in the traveled way.

Short Term Work Zone Speed Limit signs should be posted and visible to the motorists only when work activity is present. When work activity is not present, signs shall be removed or covered. (See Removing or Covering on BC(4)).

GENERAL NOTES

1. Regulatory work zone speed limits should be used only for sections of construction projects where speed control is of major importance.
2. Regulatory work zone speed limit signs shall be placed on supports at a 7 foot minimum mounting height.
3. Speed zone signs are illustrated for one direction of travel and are normally posted for each direction of travel.
4. Frequency of work zone speed limit signs should be:
 - 40 mph and greater 0.2 to 2 miles
 - 35 mph and less 0.2 to 1 mile
5. Regulatory speed limit signs shall have black legend and border on a white reflective background (See "Reflective Sheeting" on BC(4)).
6. Fabrication, erection and maintenance of the "ADVANCE SPEED LIMIT" (CW3-5) sign, "WORK ZONE" (G20-5aP) plaque and the "SPEED LIMIT" (R2-1) signs shall not be paid for directly, but shall be considered subsidiary to Item 502.
7. Turning signs from view, laying signs over or down will not be allowed, unless as otherwise noted under "REMOVING OR COVERING" on BC(4).
8. Techniques that may help reduce traffic speeds include but are not limited to:
 - A. Law enforcement.
 - B. Flagger stationed next to sign.
 - C. Portable changeable message sign (PCMS).
 - D. Low-power (drone) radar transmitter.
 - E. Speed monitor trailers or signs.
9. Speeds shown on details above are for illustration only. Work Zone Speed Limits should only be posted as approved for each project.
10. For more specific guidance concerning the type of work, work zone conditions and factors impacting allowable regulatory construction speed zone reduction see TxDOT form #1204 in the TxDOT e-form system.

DISCLAIMER: The use of this standard is governed by the "Texas Engineering Practice Act". No warranty of any kind is made by TxDOT for any purpose whatsoever. TxDOT assumes no responsibility for the conversion of units or for any errors or omissions in the drawings or for any damages resulting from the use.

DATE: 4/12/2023 7:22:43 AM
FILE: T:\LFK\DM\Int\Contr\contracts\0-RMC - Routine Maintenance Contracts\123 - 9-07-13\001-6442-70-001-96-ETC.dgn

SHEET 3 OF 12

Texas Department of Transportation		Traffic Safety Division Standard	
<h2 style="margin: 0;">BARRICADE AND CONSTRUCTION WORK ZONE SPEED LIMIT</h2>			
<h3 style="margin: 0;">BC (3) - 21</h3>			
FILE: dc-21.dgn	DW: TxDOT	CK: TxDOT	DW: TxDOT
© TxDOT November 2002	CONT SECT	JOB	HIGHWAY
REVISORS	6442 70	001	US 96, ETC.
9-07 8-14	DIST	COUNTY	SHEET NO.
7-13 5-21	LFK	SABINE	8

TYPICAL MINIMUM CLEARANCES FOR LONG TERM AND INTERMEDIATE TERM SIGNS

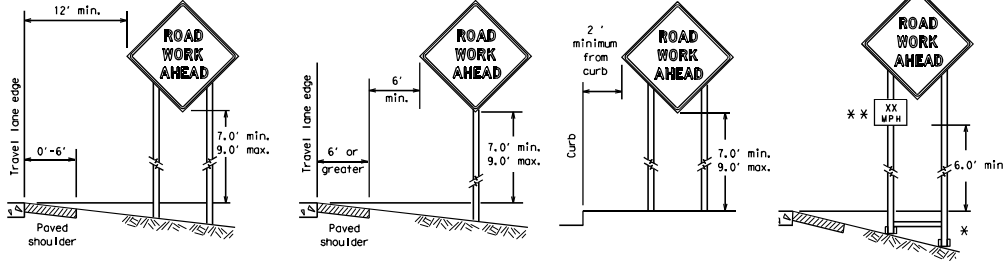

* When placing skid supports on unlevel ground, the leg post lengths must be adjusted so the sign appears straight and plumb. Objects shall NOT be placed under skids as a means of leveling.

** When plaques are placed on dual-leg supports, they should be attached to the upright nearest the travel lane. Supplemental plaques (advisory or distance) should not cover the surface of the nearest sign.

ATTACHMENT FOR SIGN SUPPORTS

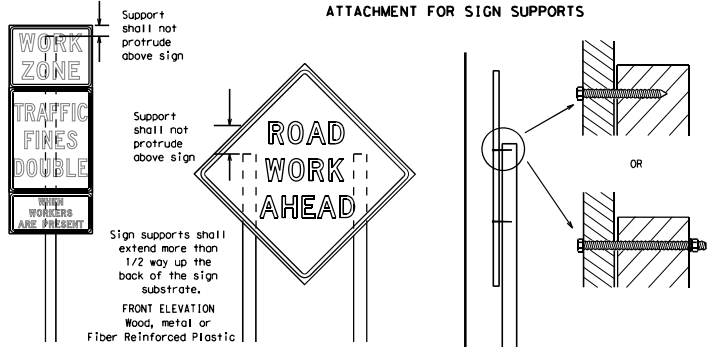

Attachment to wooden supports will be by bolts and nuts or screws. Use TxDOT's or manufacturer's recommended procedures for attaching sign substrates to other types of sign supports

Nails shall NOT be allowed.
Each sign shall be attached directly to the sign support. Multiple signs shall not be joined or spliced by any means. Wood supports shall not be extended or repaired by splicing or other means.

Splicing embedded perforated square metal tubing in order to extend post height will only be allowed when the splice is made using four bolts, two above and two below the splice point. Splice must be located entirely behind the sign substrate, not near the base of the support. Splice insert lengths should be at least 5 times nominal post size, centered on the splice and of at least the same gauge material.

STOP/SLOW PADDLES

- STOP/SLOW paddles are the primary method to control traffic by flaggers. The STOP/SLOW paddle size should be 24" x 24".
- STOP/SLOW paddles shall be retroreflective when used at night.
- STOP/SLOW paddles may be attached to a staff with a minimum length of 6' to the bottom of the sign.
- Any lights incorporated into the STOP or SLOW paddle faces shall only be as specifically described in Section 6E.03 Hand Signaling Devices in the TMDOT.

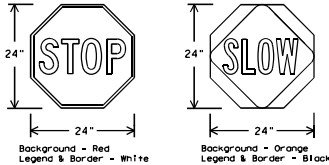

SHEETING REQUIREMENTS (WHEN USED AT NIGHT)		
USAGE	COLOR	SIGN FACE MATERIAL
BACKGROUND	RED	TYPE B OR C SHEETING
BACKGROUND	ORANGE	TYPE B _L OR C _L SHEETING
LEGEND & BORDER	WHITE	TYPE B OR C SHEETING
LEGEND & BORDER	BLACK	ACRYLIC NON-REFLECTIVE FILM

CONTRACTOR REQUIREMENTS FOR MAINTAINING PERMANENT SIGNS WITHIN THE PROJECT LIMITS

- Permanent signs are used to give notice of traffic laws or regulations, call attention to conditions that are potentially hazardous to traffic operations, show route designations, destinations, directions, distances, services, points of interest, and other geographical, recreational, specific service (L000), or cultural information. Drivers proceeding through a work zone need the same, if not better route guidance as normally installed on a roadway without construction.
- When permanent regulatory or warning signs conflict with work zone conditions, remove or cover the permanent signs until the permanent sign message matches the roadway condition. For details for covering large guide signs see the TS-CD standard.
- When existing permanent signs are moved and relocated due to construction purposes, they shall be visible to motorists at all times.
- If existing signs are to be relocated on their original supports, they shall be installed on crashworthy bases as shown on the SMD Standard sheets. The signs shall meet the required mounting heights shown on the BC sheets or the SMD Standards. This work should be paid for under the appropriate pay item for relocating existing signs.
- If permanent signs are to be removed and relocated using temporary supports, the Contractor shall use crashworthy supports as shown on the BC standard sheets, TLRs standard sheets or the CWZTCD list. The signs shall meet the required mounting heights shown on the BC, or the SMD standard sheets during construction. This work should be paid for under the appropriate pay item for relocating existing signs.
- Any sign or traffic control device that is struck or damaged by the Contractor or his/her construction equipment shall be replaced as soon as possible by the Contractor to ensure proper guidance for the motorists. This will be subsidiary to item 502.

GENERAL NOTES FOR WORK ZONE SIGNS

- Contractor shall install and maintain signs in a straight and plumb condition and/or as directed by the Engineer.
- Wooden sign posts shall be painted white.
- Barricades shall NOT be used as sign supports.
- All signs shall be installed in accordance with the plans or as directed by the Engineer. Signs shall be used to regulate, warn, and guide the traveling public safely through the work zone.
- The Contractor may furnish either the sign design shown in the plans or in the "Standard Highway Sign Designs for Texas" (SHSD). The Engineer/Inspector may require the Contractor to furnish other work zone signs that are shown in the TMDOT but may have been omitted from the plans. Any deviation in the plans shall be documented by written agreement between the Engineer and the Contractor's Responsible Person. All changes must be documented in writing before being implemented. This can include documenting the changes in the Inspector's TxDOT diary and having both the Inspector and Contractor initial and date the agreed upon changes.
- The Contractor shall furnish sign supports listed in the "Compliant Work Zone Traffic Control Device List" (CWZTCD) for small roadside signs. Supports for temporary large roadside signs shall meet the requirements detailed on the Temporary Large Roadside Signs (TLRS) standard sheets. The Contractor shall install the sign support in accordance with the manufacturer's recommendations. If there is a question regarding installation procedures, the Contractor shall furnish the Engineer a copy of the manufacturer's installation recommendations so the Engineer can verify the correct procedures are being followed.
- The Contractor is responsible for installing signs on approved supports and replacing signs with damaged or cracked substrates and/or damaged or marred reflective sheeting as directed by the Engineer/Inspector.
- Identification markings may be shown only on the back of the sign substrate. The maximum height of letters and/or company logos used for identification shall be 1 inch.
- The Contractor shall replace damaged wood posts. New or damaged wood sign posts shall not be spliced.

DURATION OF WORK (as defined by the "Texas Manual on Uniform Traffic Control Devices" Part 6)

- The types of sign supports, sign mounting height, the size of signs, and the type of sign substrates can vary based on the type of work being performed. The Engineer is responsible for selecting the appropriate size sign for the type of work being performed. The Contractor is responsible for ensuring the sign support, sign mounting height and substrate meets manufacturer's recommendations in regard to crashworthiness and duration of work requirements.
 - Long-term stationary - work that occupies a location more than 3 days.
 - Intermediate-term stationary - work that occupies a location more than one daylight period up to 3 days, or nighttime work lasting more than one hour.
 - Short-term stationary - daytime work that occupies a location for more than 1 hour in a single daylight period.
 - Short, duration - work that occupies a location up to 1 hour.
 - Mobile - work that moves continuously or intermittently (stopping for up to approximately 15 minutes.)

SIGN MOUNTING HEIGHT

- The bottom of Long-Term/Intermediate-term signs shall be at least 7 feet, but not more than 9 feet, above the paved surface, except as shown for supplemental plaques mounted below other signs.
- The bottom of Short-term/Short Duration signs shall be a minimum of 1 foot above the pavement surface but no more than 2 feet above the ground.
- Long-term/Intermediate-term Signs may be used in lieu of Short-term/Short Duration signing.
- Short-term/Short Duration signs shall be used only during daylight and shall be removed at the end of the workday or raised to appropriate Long-term/Intermediate sign height.
- Regulatory signs shall be mounted at least 7 feet, but not more than 9 feet, above the paved surface regardless of work duration.

SIGN SIZES

- The Contractor shall furnish the sign sizes shown on BC (2) unless otherwise shown in the plans or as directed by the Engineer.

SIGN SUBSTRATES

- The Contractor shall ensure the sign substrate is installed in accordance with the manufacturer's recommendations for the type of sign support that is being used. The CWZTCD lists each substrate that can be used on the different types and models of sign supports.
- "Mesh" type materials are NOT an approved sign substrate, regardless of the tightness of the weave.
- All wooden individual sign panels fabricated from 2 or more pieces shall have one or more plywood cleat, 1/2" thick by 6" wide, fastened to the back of the sign and extending fully across the sign. The cleat shall be attached to the back of the sign using wood screws that do not penetrate the face of the sign panel. The screws shall be placed on both sides of the splice and spaced at 6" centers. The Engineer may approve other methods of splicing the sign face.

REFLECTIVE SHEETING

- All signs shall be retroreflective and constructed of sheeting meeting the color and retro-reflectivity requirements of DMS-8300 for rigid signs or DMS-8310 for roll-up signs. The web address for DMS specifications is shown on BC(1).
- White sheeting, meeting the requirements of DMS-8300 Type A₁, shall be used for signs with a white background.
- Orange sheeting, meeting the requirements of DMS-8300 Type B_L or Type C_L, shall be used for rigid signs with orange backgrounds.

SIGN LETTERS

- All sign letters and numbers shall be clear, and open rounded type uppercase alphabet letters as approved by the Federal Highway Administration (FHWA) and as published in the "Standard Highway Sign Design for Texas" manual. Signs, letters and numbers shall be of first class workmanship in accordance with Department Standards and Specifications.

REMOVING OR COVERING

- When sign messages may be confusing or do not apply, the signs shall be removed or completely covered.
- Long-term stationary or intermediate stationary signs installed on square metal tubing may be turned away from traffic 90 degrees when the sign message is not applicable. This technique may not be used for signs installed in the median of divided highways or near any intersections where the sign may be seen from approaching traffic.
- Signs installed on wooden skids shall not be turned at 90 degree angles to the roadway. These signs should be removed or completely covered when not required.
- When signs are covered, the material used shall be opaque, such as heavy mil black plastic, or other materials which will cover the entire sign face and maintain their opaque properties under automobile headlights at night, without damaging the sign sheeting.
- Burlap shall NOT be used to cover signs.
- Duct tape or other adhesive material shall NOT be affixed to a sign face.
- Signs and anchor studs shall be removed and holes backfilled upon completion of work.

SIGN SUPPORT WEIGHTS

- Where sign supports require the use of weights to keep from turning over, the use of sandbags with dry, construction sand shall be used and shall be:
 - The sandbags will be tied shut to keep the sand from spilling and to maintain a constant weight.
 - Rock, concrete, iron, steel or other solid objects shall not be permitted for use as sign support weights.
 - Sandbags should weigh a minimum of 35 lbs and a maximum of 50 lbs.
 - Sandbags shall be made of a durable material that tears upon vehicular impact. Rubber (such as fire inner tubes) shall NOT be used.
 - Rubber ball or channelizing devices shall not be used for ballast on portable sign supports. Sign supports designed and manufactured with rubber bases may be used when shown on the CWZTCD list.
 - Sandbags shall only be placed along or laid over the base supports of the traffic control device and shall not be suspended above ground level or hung with rope, wire, chains or other fasteners. Sandbags shall be placed along the length of the skids to weigh down the sign support.
 - Sandbags shall NOT be placed under the skid and shall not be used to level sign supports placed on slopes.

FLAGS ON SIGNS

- Flags may be used to draw attention to warning signs. When used, the flag shall be 16 inches square or larger and shall be orange or fluorescent red-orange in color. Flags shall not be allowed to cover any portion of the sign face.

Texas Department of Transportation

Traffic Safety Division Standard

BARRICADE AND CONSTRUCTION TEMPORARY SIGN NOTES

BC (4) - 21

FILE:	bc-21.dgn	DATE:	TxDOT	DATE:	TxDOT	DATE:	TxDOT	DATE:	TxDOT
REVISED:	November 2002	DATE:	6442	DATE:	70	DATE:	001	DATE:	US 96, ETC.
DATE:	9-07	DATE:	8-14	DATE:		DATE:		DATE:	
FILE:	7-13	DATE:	5-21	DATE:		DATE:		DATE:	
		DATE:		DATE:		DATE:		DATE:	

DISCLAIMER: The use of this standard is governed by the "Texas Engineering Practice Act". No warranty of any kind is made by the TxDOT for the use of this standard or for incorrect results or damages resulting from its use. DATE: 4/12/2023 7:22:44 AM FILE: T:\LFDK\WgIntn\Contracts\0-RMC - Routine Maintenance Contracts\1723 Plans\6442-70-001 Sabine WgR\WgR\STD30-21.dgn

DISCLAIMER: The use of this standard is governed by the "Texas Engineering Practice Act". No warranty of any kind is made by the manufacturer of this standard or other materials for incorrect results or damages resulting from its use.

DATE: 4/12/2023 7:22:45 AM
 FILE: T:\LFKDM\Int Contracts\0-RMC - Routine Maintenance Contracts\123 Plans\6442-70-001 Sabine W&F STD\NSC-21.dgn

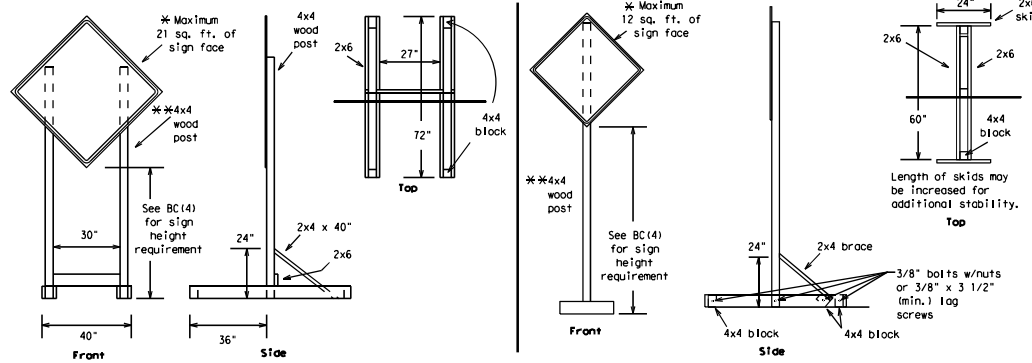

SKID MOUNTED WOOD SIGN SUPPORTS

* LONG/INTERMEDIATE TERM STATIONARY - PORTABLE SKID MOUNTED SIGN SUPPORTS

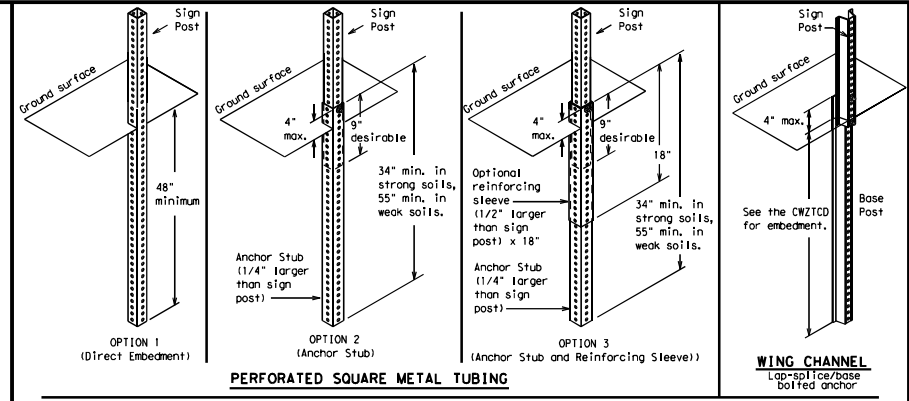

GROUND MOUNTED SIGN SUPPORTS

Refer to the CWZTCD and the manufacturer's installation procedure for each type sign support. The maximum sign square footage shall adhere to the manufacturer's recommendation. Two post installations can be used for larger signs.

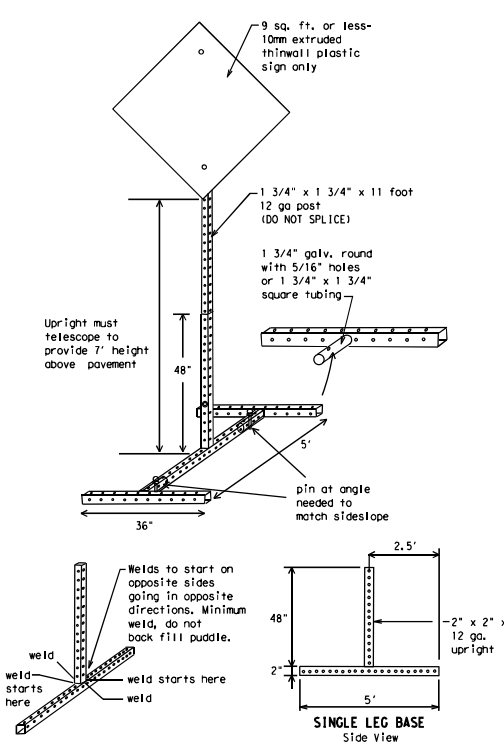

SKID MOUNTED PERFORATED SQUARE STEEL TUBING SIGN SUPPORTS

* LONG/INTERMEDIATE TERM STATIONARY - PORTABLE SKID MOUNTED SIGN SUPPORTS

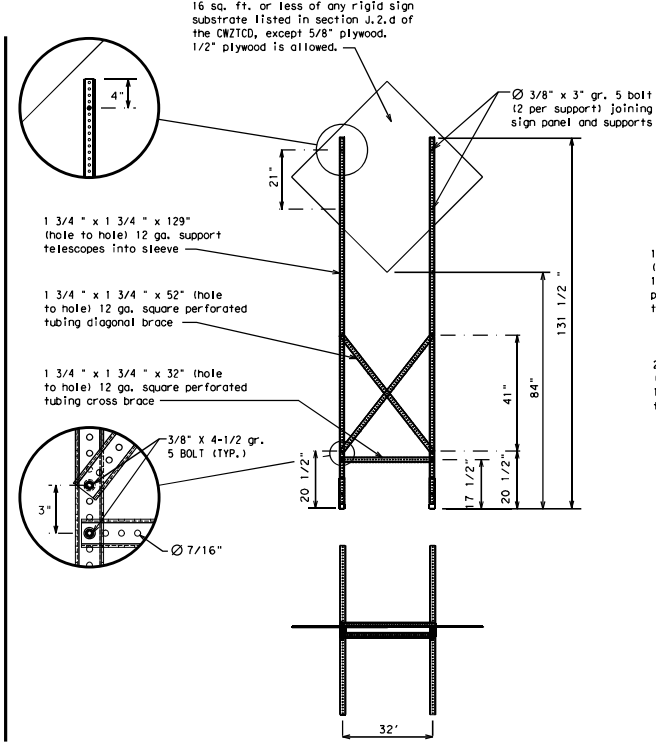

WEDGE ANCHORS

Both steel and plastic Wedge Anchor Systems as shown on the SMD Standard Sheets may be used as temporary sign supports for signs up to 10 square feet of sign face. They may be set in concrete or in sturdy soils if approved by the Engineer. (See web address for "Traffic Engineering Standard Sheets" on BC(1)).

OTHER DESIGNS

MORE DETAILS OF APPROVED LONG/INTERMEDIATE AND SHORT TERM SUPPORTS CAN BE FOUND ON THE CWZTCD LIST. SEE BC(1) FOR WEBSITE LOCATION.

GENERAL NOTES

1. Nails may be used in the assembly of wooden sign supports, but 3/8" bolts with nuts or 3/8" x 1 1/2" lag screws must be used on every joint for final connection.
 2. No more than 2 sign posts shall be placed within a 7 ft. circle, except for specific materials noted on the CWZTCD List.
 3. When project is completed, all sign supports and foundations shall be removed from the project site. This will be considered subsidiary to Item 502.
- * See BC(4) for definition of "Work Duration."
 ** Wood sign posts MUST be one piece. Splicing will NOT be allowed. Posts shall be painted white.
 See the CWZTCD for the type of sign substrate that can be used for each approved sign support.

SHEET 5 OF 12



BARRICADE AND CONSTRUCTION TYPICAL SIGN SUPPORT

BC(5) - 21

FILE:	bc-21.dgn	DATE:	TxDOT	DATE:	TxDOT	DATE:	TxDOT
REVISED:	November 2002	CONT:	6442	TO:	70	JOB:	001
DATE:	9-07	DATE:	8-14	COUNTY:	US 96, ETC.	DATE:	7-13
FILE:	LFK	DATE:	5-21	COUNTY:	SABINE	DATE:	10

WHEN NOT IN USE, REMOVE THE PCMS FROM THE RIGHT-OF-WAY OR PLACE THE PCMS BEHIND BARRIER OR GUARDRAIL WITH SIGN PANEL TURNED PARALLEL TO TRAFFIC

PORTABLE CHANGEABLE MESSAGE SIGNS

- The Engineer/Inspector shall approve all messages used on portable changeable message signs (PCMS).
- Messages on PCMS should contain no more than 8 words (about four to eight characters per word), not including simple words such as "TO," "FOR," "AT," etc.
- Messages should consist of a single phase, or two phases that alternate. Three-phase messages are not allowed. Each phase of the message should convey a single thought, and must be understood by itself.
- Use the word "EXIT" to refer to an exit ramp on a freeway; i.e., "EXIT CLOSED." Do not use the term "RAMP."
- Always use the route or interstate designation (IH, US, SH, FM) along with the number when referring to a roadway.
- When in use, the bottom of a stationary PCMS message panel should be a minimum 7 feet above the roadway, where possible. The message term "NEEKEND" should be used only if the work is to start on Saturday morning and end by Sunday evening at midnight. Actual days and hours of work should be displayed on the PCMS if work is to begin on Friday evening and/or continue into Monday morning.
- The Engineer/Inspector may select one of two options which are available for displaying a two-phase message on a PCMS. Each phase may be displayed for either four seconds each or for three seconds each. Do not use "flash" messages or words included in a message. The message should be steady burn or continuous while displayed.
- Do not present redundant information on a two-phase message; i.e., keeping two lines of the message the same and changing the third line. Do not use the word "Danger" in message.
- Do not display the message "LANES SHIFT LEFT" or "LANES SHIFT RIGHT" on a PCMS. Drivers do not understand the message.
- Do not display messages that scroll horizontally or vertically across the face of the sign.
- The following table lists abbreviated words and two-word phrases that are acceptable for use on a PCMS. Both words in a phrase must be displayed together. Words or phrases not on this list should not be abbreviated, unless shown in the table.
- PCMS character height should be at least 18 inches for trailer mounted units. They should be visible from at least 1/2 (.5) mile and the text should be legible from at least 600 feet at night and 800 feet in daylight. Truck mounted units must have a character height of 10 inches and must be legible from at least 400 feet.
- Each line of text should be centered on the message board rather than left or right justified.
- If disabled, the PCMS should default to an illegible display that will not alarm motorists and will only be used to alert workers that the PCMS has malfunctioned. A pattern such as a series of horizontal solid bars is appropriate.

RECOMMENDED PHASES AND FORMATS FOR PCMS MESSAGES DURING ROADWORK ACTIVITIES

(The Engineer may approve other messages not specifically covered here.)

Phase 1: Condition Lists

Road/Lane/Ramp Closure List

FREEWAY CLOSED X MILE	FRONTAGE ROAD CLOSED
ROAD CLOSED AT SH XXX	SHOULDER CLOSED XXX FT
ROAD CLSD AT FM XXXX	RIGHT LN CLOSED XXX FT
RIGHT X LANES CLOSED	RIGHT X LANES OPEN
CENTER LANE CLOSED	DAYTIME LANE CLOSURES
NIGHT LANE CLOSURES	I-XX SOUTH EXIT CLOSED
VARIOUS LANES CLOSED	EXIT XXX CLOSED X MILE
EXIT CLOSED	RIGHT LN TO BE CLOSED
MALL DRIVEWAY CLOSED	X LANES CLOSED TUE - FRI
XXXXXXXX BLVD CLOSED	

Other Condition List

ROADWORK XXX FT	ROAD REPAIRS XXXX FT
FLAGGER XXXX FT	LANE NARROWS XXXX FT
RIGHT LN CLOSED XXXX FT	TWO-WAY TRAFFIC XX MILE
MERGING TRAFFIC XXXX FT	CONST TRAFFIC XXX FT
LOOSE GRAVEL XXXX FT	UNEVEN LANES XXXX FT
DETOUR X MILE	ROUGH ROAD XXXX FT
ROADWORK PAST SH XXXX	ROADWORK NEXT FRI-SUN
BUMP XXXX FT	US XXX EXIT X MILES
TRAFFIC SIGNAL XXXX FT	LANES SHIFT *

* LANES SHIFT in Phase 1 must be used with STAY IN LANE in Phase 2.

Phase 2: Possible Component Lists

Action to Take/Effect on Travel List

MERGE RIGHT	FORM X LINES RIGHT
DETOUR NEXT X EXITS	USE XXXXX RD EXIT
USE EXIT XXX	USE EXIT I-XX NORTH
STAY ON US XXX SOUTH	USE I-XX E TO I-XX N
TRUCKS USE US XXX N	WATCH FOR TRUCKS
WATCH FOR TRUCKS	EXPECT DELAYS
EXPECT DELAYS	PREPARE TO STOP
REDUCE SPEED XXX FT	END SHOULDER USE
USE OTHER ROUTES	WATCH FOR WORKERS
STAY IN LANE *	

Location List

AT FM XXXX	BEFORE RAILROAD CROSSING	XXXXXX TO XXXXXXX	US XXX TO FM XXXX
------------	--------------------------	-------------------	-------------------

Warning List

SPEED LIMIT XX MPH	MAXIMUM SPEED XX MPH	MINIMUM SPEED XX MPH	ADVISORY SPEED XX MPH	RIGHT LANE EXIT	USE CAUTION	DRIVE SAFELY	DRIVE WITH CARE
--------------------	----------------------	----------------------	-----------------------	-----------------	-------------	--------------	-----------------

**** Advance Notice List**

TUE-FRI XX AM - X PM	APR XX - XX X PM-X AM	BEGINS MONDAY	BEGINS MAY XX	MAY X-X XX PM - XX AM	NEXT FRI-SUN	XX AM TO XX PM	NEXT TUE AUG XX	TONIGHT XX PM - XX AM
----------------------	-----------------------	---------------	---------------	-----------------------	--------------	----------------	-----------------	-----------------------

** See Application Guidelines Note 6.

APPLICATION GUIDELINES

- Only 1 or 2 phases are to be used on a PCMS.
- The 1st phase (or both) should be selected from the "Road/Lane/Ramp Closure List" and the "Other Condition List".
- A 2nd phase can be selected from the "Action to Take/Effect on Travel, Location, General Warning, or Advance Notice Phase Lists".
- A Location Phase is necessary only if a distance or location is not included in the first phase selected.
- If two PCMS are used in sequence, they must be separated by a minimum of 1000 ft. Each PCMS shall be limited to two phases, and should be understandable by themselves.
- For advance notice, when the current date is within seven days of the actual work date, calendar days should be replaced with days of the week. Advance notification should typically be for no more than one week prior to the work.

WORDING ALTERNATIVES

- The words RIGHT, LEFT and ALL can be interchanged as appropriate.
- Roadway designations IH, US, SH, FM and LP can be interchanged as appropriate.
- EAST, WEST, NORTH and SOUTH (or abbreviations E, W, N and S) can be interchanged as appropriate.
- Highway names and numbers replaced as appropriate.
- ROAD, HIGHWAY and FREEWAY can be interchanged as needed.
- AHEAD may be used instead of distances if necessary.
- FT and MI, MILE and MILES interchanged as appropriate.
- AT, BEFORE and PAST interchanged as needed.
- Distances or AHEAD can be eliminated from the message if a location phase is used.

PCMS SIGNS WITHIN THE R.O.W. SHALL BE BEHIND GUARDRAIL OR CONCRETE BARRIER OR SHALL HAVE A MINIMUM OF FOUR (4) PLASTIC DRUMS PLACED PERPENDICULAR TO TRAFFIC ON THE UPSTREAM SIDE OF THE PCMS, WHEN EXPOSED TO ONE DIRECTION OF TRAFFIC. WHEN EXPOSED TO TWO WAY TRAFFIC, THE FOUR DRUMS SHOULD BE PLACED WITH ONE DRUM AT EACH OF THE FOUR CORNERS OF THE UNIT.

FULL MATRIX PCMS SIGNS

- When Full Matrix PCMS signs are used, the character height and legibility/visibility requirements shall be maintained as listed in Note 15 under "PORTABLE CHANGEABLE MESSAGE SIGNS" above.
- When symbol signs, such as the "Flagger Symbol" (CW20-7) are represented graphically on the Full Matrix PCMS sign and, with the approval of the Engineer, it shall maintain the legibility/visibility requirement listed above.
- When symbol signs are represented graphically on the Full Matrix PCMS, they shall only supplement the use of the static sign represented, and shall not substitute for, or replace that sign.
- A full matrix PCMS may be used to simulate a flashing arrow board provided it meets the visibility, flash rate and dimming requirements on BC(7), for the same size arrow.

DISCLAIMER: The use of this standard is governed by the "Texas Engineering Practice Act". No warranty of any kind is made by the Board of Professional Engineers, Architects, and Surveyors. The Board's conversion of this standard to other formats or for incorrect results or damages resulting from its use. FILE: T-1\FKDMaint\Contracrs\0-RMC - Routine Maintenance Contracrs\123 Plans\6442-70-001 Sabine\6442-70-001_Sabine\M6442-70-001.dgn

WORD OR PHRASE	ABBREVIATION	WORD OR PHRASE	ABBREVIATION
Access Road	ACCS RD	Major	MAJ
Alternate	ALT	Miles	MI
Avenue	AVE	Miles Per Hour	MPH
Best Route	BEST RTE	Minor	MNR
Boulevard	BLVD	Monday	MON
Bridge	BRDG	Normal	NORM
Cannot	CANT	North	N
Center	CTR	Northbound (route) N	
Construction Ahead	CONST AHD	Parking	PKING
CROSSING	XING	Road	RD
Detour Route	DETOUR RTE	Right Lane	RT LN
Do Not	DONT	Saturday	SAT
East	E	Service Road	SERV RD
Eastbound (route) E		Shoulder	SHLDR
Emergency	EMER	Slippery	SLIP
Emergency Vehicle	EMER VEH	South	S
Entrance, Enter	ENT	Southbound (route) S	
Express Lane	EXP LN	Speed	SPD
Expressway	EXPWY	Street	ST
XXXX Feet	XXXX FT	Sunday	SUN
Flag Ahead	FLG AHD	Telephone	PHONE
Freeway	FRWY, FWY	Temporary	TRMPT
Freeway Blocked	FWY BLKD	Thursday	THURS
Friday	FRI	To Downtown	TO DOWNTN
Hazardous Driving	HAZ DRIVING	Traffic	TRAF
Hazardous Material	HAZMAT	Travelers	TRVLRS
High Occupancy	HOV	Tuesday	TUES
Vehicle	VEH	Time Minutes	TIME MIN
Hour(s)	HR, HRS	Upper Level	UPPR LEVEL
Information	INFO	Vehicles (s)	VEH, VEHs
Left	L	Warning	WARN
Junction	JCT	Wednesday	WED
Left Lane	LFT LN	Weight Limit	WT LIMIT
Lane Closed	LN CLOSED	West	W
Lower Level	LRR LEVEL	Westbound (route) W	
Maintenance	MAINT	Wet Pavement	WET PVMT
		Will Not	WONT

Roadway designation = IH-number, US-number, SH-number, FM-number

BARRICADE AND CONSTRUCTION PORTABLE CHANGEABLE MESSAGE SIGN (PCMS)			
BC (6) - 21			
FILE: dc-21.dgn	DNV: TXDOT	CHK: TXDOT	DRW: TXDOT
REV: November 2002	CONT: 6442	SECT: 70	JOB: 001
9-07	8-14	DIST: LFK	COUNTY: SABINE
7-13	5-21		SHEET NO. 11

DISCLAIMER: This sheet is prepared by the Texas Engineering, Precast, Inc. No warranty of any kind is made by TxDOT for any purpose whatsoever. TxDOT assumes no responsibility for the conversion of this standard to other formats or for incorrect results or damages resulting from its use.

- Barrier Reflectors shall be pre-qualified, and conform to the color and reflectivity requirements of DMS-8600. A list of prequalified Barrier Reflectors can be found at the Material Producer List web address shown on BC(1).
- Color of Barrier Reflectors shall be as specified in the TMUTCD. The cost of the reflectors shall be considered subsidiary to Item 512.

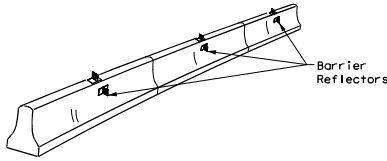

- Where traffic is on one side of the CTB, two (2) Barrier Reflectors shall be mounted in approximately the midsection of each section of CTB. An alternate mounting location is uniformly spaced at one end of each CTB. This will allow for attachment of a barrier grapple without damaging the reflector. The Barrier Reflector mounted on the side of the CTB shall be located directly below the reflector mounted on top of the barrier, as shown in the detail above.
- Where CTB separates two-way traffic, three barrier reflectors shall be mounted on each section of CTB. The reflector unit on top shall have two yellow reflective faces (Bi-Directional) while the reflectors on each side of the barrier shall have one yellow reflective face, as shown in the detail above.
- When CTB separates traffic traveling in the same direction, no barrier reflectors will be required on top of the CTB.
- Barrier Reflector units shall be yellow or white in color to match the edgeline being supplemented.
- Maximum spacing of Barrier Reflectors is forty (40) feet.
- Pavement markers or temporary flexible-reflective roadway marker tabs shall NOT be used as CTB delineation.
- Attachment of Barrier Reflectors to CTB shall be per manufacturer's recommendations.
- Missing or damaged Barrier Reflectors shall be replaced as directed by the Engineer.
- Single slope barriers shall be delineated as shown on the above detail.

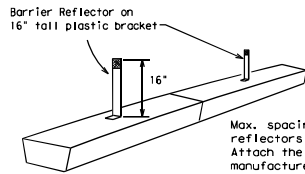

LOW PROFILE CONCRETE BARRIER (LPCB) USED IN WORK ZONES

LPCB is approved for use in work zone locations, where the posted speed is 45mph, or less. See Roadway Standard Sheet LPCB.

Max. spacing of barrier reflectors is 20 feet. Attach the delineators as per manufacturer's recommendations.

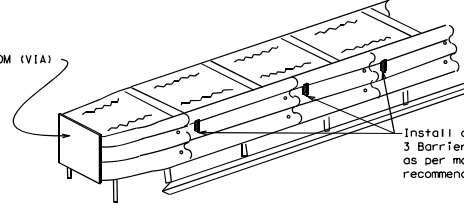

END TREATMENTS FOR CTB'S USED IN WORK ZONES

End treatments used on CTB's in work zones shall meet the appropriate crashworthy standards as defined in the Manual for Assessing Safety Hardware (MASH). Refer to the CWZTCD List for approved end treatments and manufacturers.

BARRIER REFLECTORS FOR CONCRETE TRAFFIC BARRIER AND ATTENUATORS

WARNING LIGHTS

- Warning lights shall meet the requirements of the TMUTCD.
- Warning lights shall NOT be installed on barricades.
- Type A-Low Intensity Flashing Warning Lights are commonly used with drums. They are intended to warn or mark a potentially hazardous area. Their use shall be as indicated on this sheet and/or other sheets of the plans by the designation "FL". The Type A Warning Lights shall not be used with signs manufactured with Type B₁ or C₁ Sheeting meeting the requirements of Departmental Material Specification DMS-8300.
- Type-C and Type D 360 degree Steady Burn Lights are intended to be used in a series for delineation to supplement other traffic control devices. Their use shall be as indicated on this sheet and/or other sheets of the plans by the designation "SB".
- The Engineer/Inspector or the plans shall specify the location and type of warning lights to be installed on the traffic control devices.
- When required by the Engineer, the Contractor shall furnish a copy of the warning lights certification. The warning light manufacturer will certify the warning lights meet the requirements of the latest ITE Purchase Specifications for Flashing and Steady-Burn Warning Lights.
- When used to delineate curves, Type-C and Type D Steady Burn Lights should only be placed on the outside of the curve, not the inside.
- The location of warning lights and warning reflectors on drums shall be as shown elsewhere in the plans.

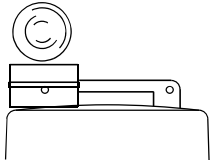

WARNING LIGHTS MOUNTED ON PLASTIC DRUMS

- Type A flashing warning lights are intended to warn drivers that they are approaching or are in a potentially hazardous area.
- Type A random flashing warning lights are not intended for delineation and shall not be used in a series.
- A series of sequential flashing warning lights placed on channelizing devices to form a merging taper may be used for delineation. If used, the successive flashing of the sequential warning lights should occur from the beginning of the taper to the end of the merging taper in order to identify the desired vehicle path. The rate of flashing for each light shall be 65 flashes per minute, plus or minus 10 flashes.
- Type C and D steady-burn warning lights are intended to be used in a series to delineate the edge of the travel lane on detours, on lane changes, on lane closures, and on other similar conditions.
- Type A, Type C and Type D warning lights shall be installed at locations as detailed on other sheets in the plans.
- Warning lights shall not be installed on a drum that has a sign, chevron or vertical panel.
- The maximum spacing for warning lights on drums should be identical to the channelizing device spacing.

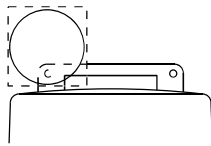

WARNING REFLECTORS MOUNTED ON PLASTIC DRUMS AS A SUBSTITUTE FOR TYPE C (STEADY BURN) WARNING LIGHTS

- A warning reflector or approved substitute may be mounted on a plastic drum as a substitute for a Type C, steady burn warning light at the discretion of the Contractor unless otherwise noted in the plans.
- The warning reflector shall be yellow in color and shall be manufactured using a sign substrate approved for use with plastic drums listed on the CWZTCD.
- The warning reflector shall have a minimum retroreflective surface area (one-side) of 30 square inches.
- Round reflectors shall be fully reflectorized, including the area where attached to the drum.
- Square substrates must have a minimum of 30 square inches of reflectorized sheeting. They do not have to be reflectorized where it attaches to the drum.
- The side of the warning reflector facing approaching traffic shall have sheeting meeting the color and retroreflectivity requirements for DMS 8300-Type B or Type C.
- When used near two-way traffic, both sides of the warning reflector shall be reflectorized.
- The warning reflector should be mounted on the side of the handle nearest approaching traffic.
- The maximum spacing for warning reflectors should be identical to the channelizing device spacing requirements.

Arrow Boards may be located behind channelizing devices in place for a shoulder taper or merging taper, otherwise they shall be delineated with four (4) channelizing devices placed perpendicular to traffic on the upstream side of traffic.

- The Flashing Arrow Board should be used for all lane closures on multi-lane roadways, or slow moving maintenance or construction activities on the travel lanes.
- Flashing Arrow Boards should not be used on two-lane, two-way roadways, detours, diversions or work on shoulders unless the "CAUTION" display (see detail below) is used.
- The Engineer/Inspector shall choose all appropriate signs, barricades and/or other traffic control devices that should be used in conjunction with the Flashing Arrow Board.
- The Flashing Arrow Board should be able to display the following symbols:

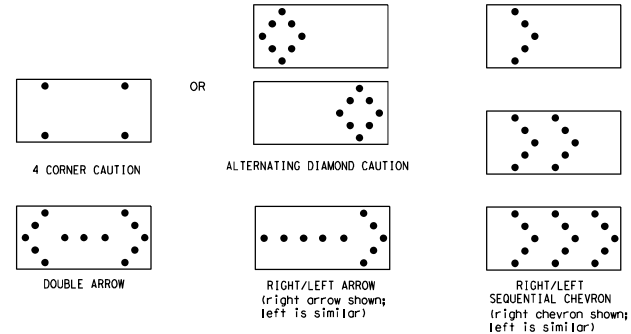

- The "CAUTION" display consists of four corner lamps flashing simultaneously, or the Alternating Diamond Caution mode as shown.
- The straight line caution display is NOT ALLOWED.
- The Flashing Arrow Board shall be capable of minimum 50 percent dimming from rated lamp voltage.
- The flashing rate of the lamps shall not be less than 25 nor more than 40 flashes per minute.
- Minimum lamp "on time" shall be approximately 50 percent for the flashing arrow and equal intervals of 25 percent for each sequential phase of the flashing chevron.
- The sequential arrow display is NOT ALLOWED.
- The flashing arrow display is the TxDOT standard; however, the sequential chevron display may be used during daylight operations.
- The Flashing Arrow Board shall be mounted on a vehicle, trailer or other suitable support.
- A Flashing Arrow Board SHALL NOT BE USED to laterally shift traffic.
- A full matrix PMS may be used to simulate a Flashing Arrow Board provided it meets visibility, flash rate and dimming requirements on this sheet for the same size arrow.
- Minimum mounting height of trailer mounted Arrow Boards should be 7 feet from roadway to bottom of panel.

REQUIREMENTS			
TYPE	MINIMUM SIZE	MINIMUM NUMBER OF PANEL LAMPS	MINIMUM VISIBILITY DISTANCE
B	30 x 60	13	3/4 mile
C	48 x 96	15	1 mile

ATTENTION
Flashing Arrow Boards shall be equipped with automatic dimming devices.

WHEN NOT IN USE, REMOVE THE ARROW BOARD FROM THE RIGHT-OF-WAY OR PLACE THE ARROW BOARD BEHIND CONCRETE TRAFFIC BARRIER OR GUARDRAIL.

FLASHING ARROW BOARDS

SHEET 7 OF 12

TRUCK-MOUNTED ATTENUATORS

- Truck-mounted attenuators (TMA) used on TxDOT facilities must meet the requirements outlined in the Manual for Assessing Safety Hardware (MASH).
- Refer to the CWZTCD for the requirements of Level 2 or Level 3 TMAs.
- Refer to the CWZTCD for a list of approved TMAs.
- TMAs are required on freeways unless otherwise noted in the plans.
- A TMA should be used anytime that it can be positioned 30 to 100 feet in advance of the area of crew exposure without adversely affecting the work performance.
- The only reason a TMA should not be required is when a work area is spread down the roadway and the work crew is an extended distance from the TMA.



BARRICADE AND CONSTRUCTION ARROW PANEL, REFLECTORS, WARNING LIGHTS & ATTENUATOR

BC (7) - 21

FILE:	bc-21.dgn	DATE:	TxDOT	DATE:	TxDOT	DATE:	TxDOT	DATE:	TxDOT
REVISED:	November 2002	DATE:	6442	DATE:	70	DATE:	001	DATE:	US 96, ETC.
REVISED:	9-07	REVISED:	8-14	REVISED:	7-13	REVISED:	5-21	REVISED:	
		DIST:	LFK	COUNTY:	SABINE	SHEET NO.:			

DATE: 4/12/2023 7:22:47 AM
FILE: T:\LKFD\MAINT\ Contracts\0-RMC - Routine Maintenance Contracts\FY23 Plans\6442-70-001 Sabine MGR_VGN\STD\BC-21.dgn

DISCLAIMER: This standard is governed by the "Texas Engineering Practice Act". No warranty of any kind is made by TxDOT for any purpose whatsoever. TxDOT assumes no responsibility for the conversion of this standard to other formats or for incorrect results or damages resulting from its use.

DATE: 4/12/2023 7:22:48 AM
 FILE: T:\LKFD\MAINT\Contractions\O-RMC - Routine Maintenance Contractions\23 Plans\6442-70-001 Sabine\MOF\MOF\STD\BC-21.dgn

GENERAL NOTES

- For long term stationary work zones on freeways, drums shall be used as the primary channelizing device.
- For intermediate term stationary work zones on freeways, drums should be used as the primary channelizing device but may be replaced in tangent sections by vertical panels, or 42" two-piece cones. In tangent sections, one-piece cones may be used with the approval of the Engineer but only if personnel are present on the project at all times to maintain the cones in proper position and location.
- For short term stationary work zones on freeways, drums are the preferred channelizing device but may be replaced in tapers, transitions and tangent sections by vertical panels, two-piece cones or one-piece cones as approved by the Engineer.
- Drums and all related items shall comply with the requirements of the current version of the "Texas Manual on Uniform Traffic Control Devices" (TMUTCD) and the "Compliant Work Zone Traffic Control Devices List" (CWZTCD).
- Drums, bases, and related materials shall exhibit good workmanship and shall be free from objectionable marks or defects that would adversely affect their appearance or serviceability.
- The Contractor shall have a maximum of 24 hours to replace any plastic drums identified for replacement by the Engineer/Inspector. The replacement device must be an approved device.

GENERAL DESIGN REQUIREMENTS

Pre-qualified plastic drums shall meet the following requirements:

- Plastic drums shall be a two-piece design; the "body" of the drum shall be the top portion and the "base" shall be the bottom.
- The body and base shall "lock" together in such a manner that the body separates from the base when impacted by a vehicle traveling at a speed of 20 MPH or greater but prevents accidental separation due to normal handling and/or air turbulence created by passing vehicles.
- Plastic drums shall be constructed of lightweight flexible, and deformable materials. The Contractor shall NOT use metal drums or single piece plastic drums as channelizing devices or sign supports.
- Drums shall present a profile that is a minimum of 18 inches in width at the 36 inch height when viewed from any direction. The height of drum unit (body installed on base) shall be a minimum of 36 inches and a maximum of 42 inches.
- The top of the drum shall have a built-in handle for easy pickup and shall be designed to drain water and not collect debris. The handle shall have a minimum of two widely spaced 9/16 inch diameter holes to allow attachment of a warning light, warning reflector unit or approved compliant sign.
- The exterior of the drum body shall have a minimum of four alternating orange and white retroreflective circumferential stripes not less than 4 inches nor greater than 8 inches in width. Any non-reflectorized space between any two adjacent stripes shall not exceed 2 inches in width.
- Bases shall have a maximum width of 36 inches, a maximum height of 4 inches, and a minimum of two footholds of sufficient size to allow base to be held down while separating the drum body from the base.
- Plastic drums shall be constructed of ultra-violet stabilized, orange, high-density polyethylene (HDPE) or other approved material.
- Drum body shall have a maximum unballasted weight of 11 lbs.
- Drum and base shall be marked with manufacturer's name and model number.

RETROREFLECTIVE SHEETING

- The stripes used on drums shall be constructed of sheeting meeting the color and retroreflectivity requirements of Departmental Materials Specification DMS-8300, "Sign Face Materials." Type A or Type B reflective sheeting shall be supplied unless otherwise specified in the plans.
- The sheeting shall be suitable for use on and shall adhere to the drum surface such that, upon vehicular impact, the sheeting shall remain adhered in-place and exhibit no delaminating, cracking, or loss of retroreflectivity other than that loss due to abrasion of the sheeting surface.

BALLAST

- Unballasted bases shall be large enough to hold up to 50 lbs. of sand. This base, when filled with the ballast material, should weigh between 35 lbs (minimum) and 50 lbs (maximum). The ballast may be sand in one to three sandbags separate from the base, sand in a sand-filled plastic base, or other ballasting devices as approved by the Engineer. Stacking of sandbags will be allowed, however height of sandbags above pavement surface may not exceed 12 inches.
- Bases with built-in ballast shall weigh between 40 lbs. and 50 lbs. Built-in ballast can be constructed of an integral crumb rubber base or a solid rubber base.
- Recycled truck tire sidewalls may be used for ballast on drums approved for this type of ballast on the CWZTCD list.
- The ballast shall not be heavy objects, water, or any material that would become hazardous to motorists, pedestrians, or workers when the drum is struck by a vehicle.
- When used in regions susceptible to freezing, drums shall have drainage holes in the bottoms so that water will not collect and freeze becoming a hazard when struck by a vehicle.
- Ballast shall not be placed on top of drums.
- Adhesives may be used to secure base of drums to pavement.

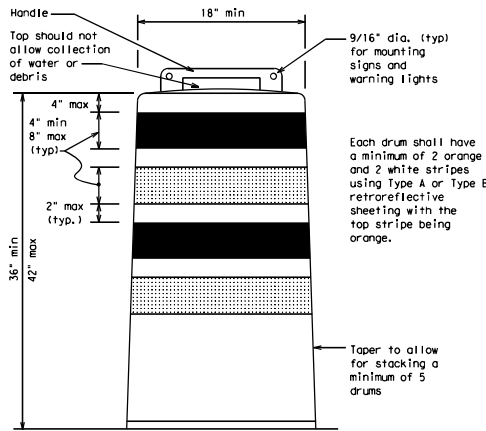

Each drum shall have a minimum of 2 orange and 2 white stripes using Type A or Type B retroreflective sheeting with the top stripe being orange.

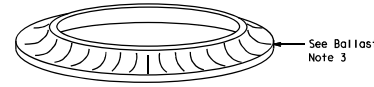

See Ballast Note 3

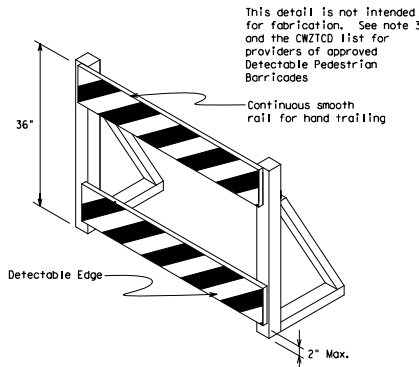

DETECTABLE PEDESTRIAN BARRICADES

- When existing pedestrian facilities are disrupted, closed, or relocated in a TTC zone, the temporary facilities shall be detectable and include accessibility features consistent with the features present in the existing pedestrian facility. Refer to WZ(BTS-2) for Pedestrian Control requirements for Sidewalk Diversions, Sidewalk Detours and Crosswalk Closures.
- Where pedestrians with visual disabilities normally use the closed sidewalk, a Detectable Pedestrian Barricade shall be placed across the full width of the closed sidewalk instead of a Type 3 Barricade.
- Detectable pedestrian barricades similar to the one pictured above, longitudinal channelizing devices, some concrete barriers, and wood or chain link fencing with a continuous detectable edging can satisfactorily delineate a pedestrian path.
- Tape, rope, or plastic chain strung between devices are not detectable, do not comply with the design standards in the "Americans with Disabilities Act Accessibility Guidelines (ADAAG)" and should not be used as a control for pedestrian movements.
- Warning lights shall not be attached to detectable pedestrian barricades.
- Detectable pedestrian barricades should use 8" nominal barricade rolls as shown on BC(10) provided that the top roll provides a smooth continuous roll suitable for hand trailing with no splinters, burrs, or sharp edges.



18" x 24" Sign
(Maximum Sign Dimension)
Chevron CW1-8, Opposing Traffic Lane Divider, Driveway Sign D70a, Keep Right R4 series or other signs as approved by Engineer

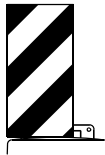

12" x 24" Vertical Panel
mount with diagonals sloping down towards travel way

Plywood, Aluminum or Metal sign substrates shall NOT be used on plastic drums

SIGNS, CHEVRONS, AND VERTICAL PANELS MOUNTED ON PLASTIC DRUMS

- Signs used on plastic drums shall be manufactured using substrates listed on the CWZTCD.
- Chevrons and other work zone signs with an orange background shall be manufactured with Type B_{FL} or Type C_{FL} Orange sheeting meeting the color and retroreflectivity requirements of DMS-8300, "Sign Face Material," unless otherwise specified in the plans.
- Vertical Panels shall be manufactured with orange and white sheeting meeting the requirements of DMS-8300 Type A or Type B. Diagonal stripes on Vertical Panels shall slope down toward the intended traveled lane.
- Other sign messages (text or symbolic) may be used as approved by the Engineer. Sign dimensions shall not exceed 18 inches in width or 24 inches in height, except for the R9 series signs discussed in note 8 below.
- Signs shall be installed using a 1/2 inch bolt (nominal) and nut, two washers, and one locking washer for each connection.
- Mounting bolts and nuts shall be fully engaged and adequately torqued. Bolts should not extend more than 1/2 inch beyond nuts.
- Chevrons may be placed on drums on the outside of curves, on merging tapers or on shifting tapers. When used in these locations, they may be placed on every drum or spaced not more than on every third drum. A minimum of three (3) should be used at each location called for in the plans.
- R9-9, R9-10, R9-11 and R9-11a Sidewalk Closed signs which are 24 inches wide may be mounted on plastic drums, with approval of the Engineer.

SHEET 8 OF 12



BARRICADE AND CONSTRUCTION CHANNELIZING DEVICES

BC (8) - 21

FILE:	bc-21.dgn	DN:	TxDOT	CR:	TxDOT	DR:	TxDOT	EX:	TxDOT
REV:	November 2002	CONT:	SECT:	JOB:	HIGHWAY:				
4-03	8-14	6442	70	001	US 96, ETC.				
9-07	5-21	DIST:	COUNTY:	SHEET NO.:					
7-13		LFK	SABINE	13					

DISCLAIMER: The use of this standard is governed by the "Texas Engineering Practice Act". No warranty of any kind is made by TxDOT for any use of this standard other than for the conversion of this standard to other formats or for incorrect results or damages resulting from its use.

DATE: 4/12/2023 7:22:49 AM
 FILE: T:\LKFD\Main\Int Contracts\0-RMC - Routine Maintenance Contracts\0-21.dgn

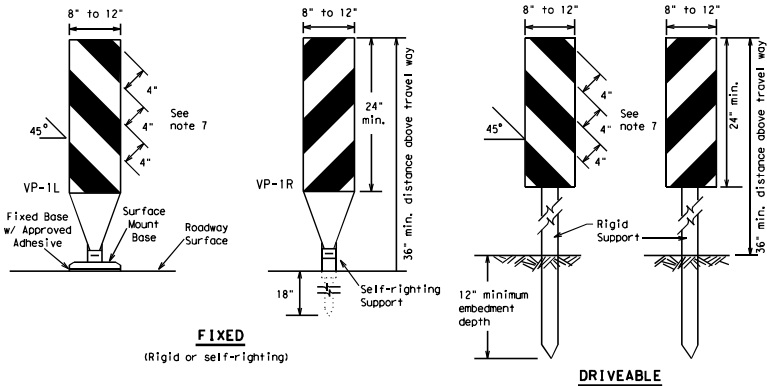

FIXED
(Rigid or self-righting)

DRIVEABLE

- Vertical Panels (VP's) are normally used to channelize traffic or divide opposing lanes of traffic.
- VP's may be used in daytime or nighttime situations. They may be used at the edge of shoulder drop-offs and other areas such as lane transitions where positive daytime and nighttime delineation is required. The Engineer/Inspector shall refer to the Roadway Design Manual for additional requirements on the use VP's for drop-offs.
- VP's should be mounted back to back if used at the edge of cuts adjacent to two-way two lane roadways. Stripes are to be reflective orange and reflective white and should always slope downward toward the travel lane.
- VP's used on expressways and freeways or other high speed roadways, may have more than 270 square inches of retroreflective area facing traffic.
- Self-righting supports are available with portable base. See "Compliant Work Zone Traffic Control Devices List" (CWZTCD).
- Sheeting for the VP's shall be retroreflective Type A or Type B conforming to Departmental Material Specification DMS-8300, unless noted otherwise.
- Where the height of reflective material on the vertical panel is 36 inches or greater, a panel stripe of 6 inches shall be used.

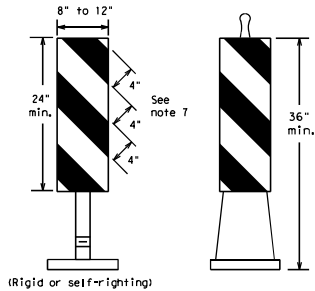

(Rigid or self-righting)

PORTABLE

VERTICAL PANELS (VPs)

- Opposing Traffic Lane Dividers (OTLD) are delineation devices designed to convert a normal one-way roadway section to two-way operation. OTLD's are used on temporary centerlines. The upward and downward arrows on the sign's face indicate the direction of traffic on either side of the divider. The base is secured to the pavement with an adhesive or rubber weight to minimize movement caused by a vehicle impact or wind gust.
- The OTLD may be used in combination with 42" cones or VPs.
- Spacing between the OTLD shall not exceed 500 feet. 42" cones or VPs placed between the OTLD's should not exceed 100 foot spacing.
- The OTLD shall be orange with a black non-reflective legend. Sheeting for the OTLD shall be retroreflective Type B₁ or Type C₁ conforming to Departmental Material Specification DMS-8300, unless noted otherwise. The legend shall meet the requirements of DMS-8300.

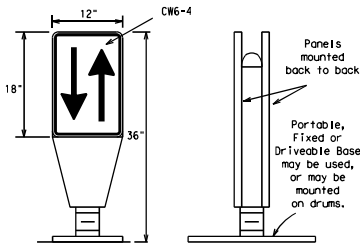

OPPOSING TRAFFIC LANE DIVIDERS (OTLD)

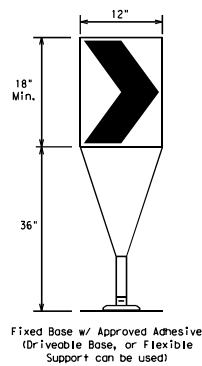

Fixed Base w/ Approved Adhesive (Driveable Base, or Flexible Support can be used)

- The chevron shall be a vertical rectangle with a minimum size of 12 by 18 inches.
- Chevrons are intended to give notice of a sharp change of alignment with the direction of travel and provide additional emphasis and guidance for vehicle operators with regard to changes in horizontal alignment of the roadway.
- Chevrons, when used, shall be erected on the outside of a sharp curve or turn, or on the far side of an intersection. They shall be in line with and at right angles to approaching traffic. Spacing should be such that the motorist always has three in view, until the change in alignment eliminates its need.
- To be effective, the chevron should be visible for at least 500 feet.
- Chevrons shall be orange with a black nonreflective legend. Sheeting for the chevron shall be retroreflective Type B₁ or Type C₁ conforming to Departmental Material Specification DMS-8300, unless noted otherwise. The legend shall meet the requirements of DMS-8300.
- For Long Term Stationary use on tapers or transitions on freeways and divided highways, self-righting chevrons may be used to supplement plastic drums but not to replace plastic drums.

CHEVRONS

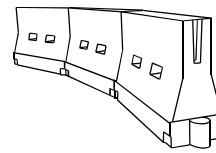

LONGITUDINAL CHANNELIZING DEVICES (LCD)

- LCDs are crashworthy, lightweight, deformable devices that are highly visible, have good target value and can be connected together. They are not designed to contain or redirect a vehicle on impact.
- LCDs may be used instead of a line of cones or drums.
- LCDs shall be placed in accordance to application and installation requirements specific to the device, and used only when shown on the CWZTCD list.
- LCDs should not be used to provide positive protection for obstacles, pedestrians or workers.
- LCDs shall be supplemented with retroreflective delineation as required for temporary barriers on BC(7) when placed roughly parallel to the travel lanes.
- LCDs used as barricades perpendicular to traffic should have at least one row of reflective sheeting meeting the requirements for barricade rails as shown on BC(10). Place reflective sheeting near the top of the LCD along the full length of the device.

WATER BALLASTED SYSTEMS USED AS BARRIERS

- Water ballasted systems used as barriers shall not be used solely to channelize road users, but also to protect the work space per the appropriate Manual for Assessing Safety Hardware (MASH) crashworthiness requirements based on roadway speed and barrier application.
- Water ballasted systems used to channelize vehicular traffic shall be supplemented with retroreflective delineation or channelizing devices to improve daytime/nighttime visibility. They may also be supplemented with pavement markings.
- Water ballasted systems used as barriers shall be placed in accordance to application and installation requirements specific to the device, and used only when shown on the CWZTCD list.
- Water ballasted systems used as barriers should not be used for a merging taper except in low speed (less than 45 MPH) urban areas. When used on a taper in a low speed urban area, the taper shall be delineated and the taper length should be designed to optimize road user operations considering the available geometric conditions.
- When water ballasted systems used as barriers have blunt ends exposed to traffic, they should be attenuated as per manufacturer recommendations or flared to a point outside the clear zone.

If used to channelize pedestrians, longitudinal channelizing devices or water ballasted systems must have a continuous detectable bottom for users of long cones and the top of the unit shall not be less than 32 inches in height.

HOLLOW OR WATER BALLASTED SYSTEMS USED AS LONGITUDINAL CHANNELIZING DEVICES OR BARRIERS

GENERAL NOTES

- Work Zone channelizing devices illustrated on this sheet may be installed in close proximity to traffic and are suitable for use on high or low speed roadways. The Engineer/Inspector shall ensure that spacing and placement is uniform and in accordance with the "Texas Manual on Uniform Traffic Control Devices" (TMUTCD).
- Channelizing devices shown on this sheet may have a driveable, fixed or portable base. The requirement for self-righting channelizing devices must be specified in the General Notes or other plan sheets.
- Channelizing devices on self-righting supports should be used in work zone areas where channelizing devices are frequently impacted by errant vehicles or vehicle related wind gusts making alignment of the channelizing devices difficult to maintain. Locations of these devices shall be detailed elsewhere in the plans. These devices shall conform to the TMUTCD and the "Compliant Work Zone Traffic Control Devices List" (CWZTCD).
- The Contractor shall maintain devices in a clean condition and replace damaged, nonreflective, faded, or broken devices and bases as required by the Engineer/Inspector. The Contractor shall be required to maintain proper device spacing and alignment.
- Portable bases shall be fabricated from virgin and/or recycled rubber. The portable bases shall weigh a minimum of 30 lbs.
- Pavement surfaces shall be prepared in a manner that ensures proper bonding between the adhesives, the fixed mount bases and the pavement surface. Adhesives shall be prepared and applied according to the manufacturer's recommendations.
- The installation and removal of channelizing devices shall not cause detrimental effects to the final pavement surfaces, including pavement surface discoloration or surface integrity. Driveable bases shall not be permitted on final pavement surfaces. The Engineer/Inspector shall approve all application and removal procedures of fixed bases.

Posted Speed	Formula	Minimum Desirable Taper Lengths **			Suggested Maximum Spacing of Channelizing Devices	
		10' Offset	11' Offset	12' Offset	On a Taper	On a Tangent
30	L = WS/60	150'	165'	180'	30'	60'
35		205'	225'	245'	35'	70'
40	L = WS	265'	295'	320'	40'	80'
45		450'	495'	540'	45'	90'
50	L = WS	500'	550'	600'	50'	100'
55		550'	605'	660'	55'	110'
60	L = WS	600'	660'	720'	60'	120'
65		650'	715'	780'	65'	130'
70	L = WS	700'	770'	840'	70'	140'
75		750'	825'	900'	75'	150'
80	L = WS	800'	880'	960'	80'	160'
85		850'	935'	1020'	85'	170'

** Taper lengths have been rounded off.
 L=Length of Taper (FT.) W=Width of Offset (FT.)
 S=Posted Speed (MPH)

SUGGESTED MAXIMUM SPACING OF CHANNELIZING DEVICES AND MINIMUM DESIRABLE TAPER LENGTHS

SHEET 9 OF 12



BARRICADE AND CONSTRUCTION CHANNELIZING DEVICES

BC (9) - 21

FILE:	bc-21.dgn	DATE:	TxDOT	DATE:	TxDOT	DATE:	TxDOT
REVISED:	November 2002	DATE:	NOV	DATE:	NOV	DATE:	NOV
REVISED:	6442	DATE:	70	DATE:	001	DATE:	US 96, ETC.
REVISED:	9-07	DATE:	8-1	DATE:		DATE:	
REVISED:	7-13	DATE:	5-21	DATE:		DATE:	
REVISED:		DATE:	LFK	DATE:	COUNTY	DATE:	SHEET NO.
REVISED:		DATE:		DATE:	SABINE	DATE:	14

103

TYPE 3 BARRICADES

1. Refer to the Compliant Work Zone Traffic Control Devices List (CWZTD) for details of the Type 3 Barricades and a list of all materials used in the construction of Type 3 Barricades.
2. Type 3 Barricades shall be used at each end of construction projects closed to all traffic.
3. Barricades extending across a roadway should have stripes that slope downward in the direction toward which traffic must turn in detouring. When both right and left turns are provided, the chevron striping may slope downward in both directions from the center of the barricade. Where no turns are provided at a closed road, striping should slope downward in both directions toward the center of roadway.
4. Striping of rails, for the right side of the roadway, should slope downward to the left. For the left side of the roadway, striping should slope downward to the right.
5. Identification markings may be shown only on the back of the barricade rails. The maximum height of letters and/or company logos used for identification shall be 1".
6. Barricades shall not be placed parallel to traffic unless an adequate clear zone is provided.
7. Warning lights shall NOT be installed on barricades.
8. Where barricades require the use of weights to keep from turning over, the use of sandbags with dry, cohesionless sand is recommended. The sandbags will be tied shut to keep the sand from spilling and to maintain a constant weight. Sand bags shall not be stacked in a manner that covers any portion of a barricade rails reflective sheeting. Rock, concrete, iron, steel or other solid objects will NOT be permitted. Sandbags should weigh a minimum of 35 lbs and a maximum of 50 lbs. Sandbags shall be made of a durable material that tears upon vehicular impact. Rubber (such as fire inner tubes) shall not be used for sandbags. Sandbags shall only be placed along or upon the base supports of the device and shall not be suspended above ground level or hung with rope, wire, chains or other fasteners.
9. Sheeting for barricades shall be retroreflective Type A or Type B conforming to Departmental Material Specification DMS-8300 unless otherwise noted.

Barricades shall NOT be used as a sign support.

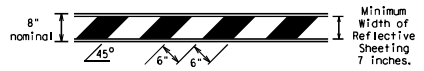

TYPICAL STRIPING DETAIL FOR BARRICADE RAIL

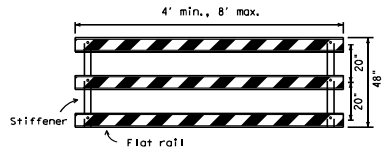

TYPICAL PANEL DETAIL FOR SKID OR POST TYPE BARRICADES

Each roadway of a divided highway shall be barricaded in the same manner.

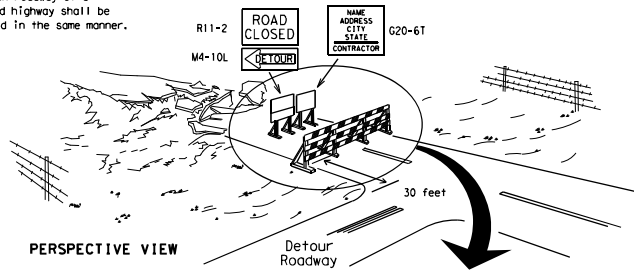

PERSPECTIVE VIEW

The three rails on Type 3 barricades shall be reflectorized orange and reflective white stripes on one side facing one-way traffic and both sides for two-way traffic. Barricade striping should slant downward in the direction of detour.

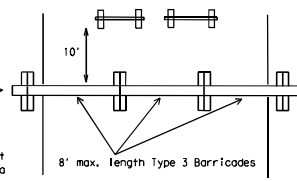

PLAN VIEW

1. Signs should be mounted on independent supports at a 7 foot mounting height in center of roadway. The signs should be a minimum of 10 feet behind Type 3 Barricades.
2. Advance signing shall be as specified elsewhere in the plans.

TYPE 3 BARRICADE (POST AND SKID) TYPICAL APPLICATION

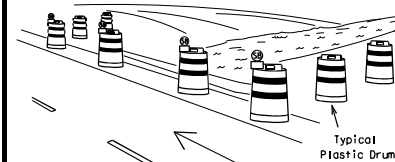

PERSPECTIVE VIEW

These drums are not required on one-way roadway

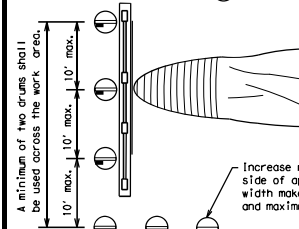

PLAN VIEW

Increase number of plastic drums on the side of approaching traffic if the crown width makes it necessary. (minimum of 2 and maximum of 4 drums)

1. Where positive redirection capability is provided, drums may be omitted.
2. Plastic construction fencing may be used with drums for safety as required in the plans.
3. Vertical Panels on flexible support may be substituted for drums when the shoulder width is less than 4 feet.
4. When the shoulder width is greater than 12 feet, steady-burn lights may be omitted if drums are used.
5. Drums must extend the length of the culvert widening.

LEGEND

	Plastic drum
	Plastic drum with steady burn light or yellow warning reflector
	Steady burn warning light or yellow warning reflector

CULVERT WIDENING OR OTHER ISOLATED WORK WITHIN THE PROJECT LIMITS

CONES

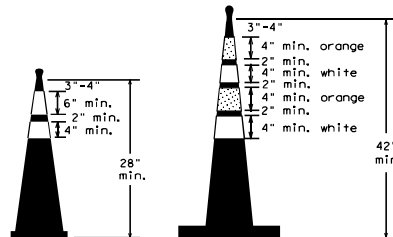

Two-Piece cones

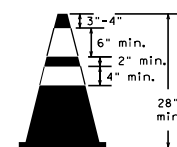

One-Piece cones

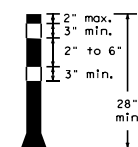

Tubular Marker

28" Cones shall have a minimum weight of 9 1/2 lbs.

42" 2-piece cones shall have a minimum weight of 30 lbs. including base.

1. Traffic cones and tubular markers shall be predominantly orange, and meet the height and weight requirements shown above.
2. One-piece cones have the body and base of the cone molded in one consolidated unit. Two-piece cones have a cone shaped body and a separate rubber base, or ballast, that is added to keep the device upright and in place.
3. Two-piece cones may have a handle or loop extending up to 8" above the minimum height shown, in order to aid in retrieving the device.
4. Cones or tubular markers shall have white or white and orange reflective bands as shown above. The reflective bands shall have a smooth, sealed outer surface and meet the requirements of Departmental Material Specification DMS-8300 Type A or Type B.
5. 28" cones and tubular markers are generally suitable for short duration and short-term stationary work as defined on BC(4). These should not be used for intermediate-term or long-term stationary work unless personnel is on-site to maintain them in their proper upright position.
6. 42" two-piece cones, vertical panels or drums are suitable for all work zone durations.
7. Cones or tubular markers used on each project should be of the same size and shape.

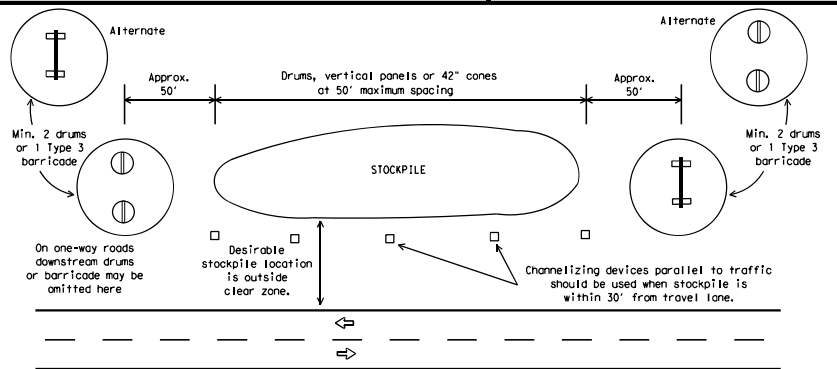

TRAFFIC CONTROL FOR MATERIAL STOCKPILES

Texas Department of Transportation
Traffic Safety Division Standard

BARRICADE AND CONSTRUCTION CHANNELIZING DEVICES

BC (10) - 21

FILE: dc-21.dgn	DATE: TXDOT	DATE: TXDOT	DATE: TXDOT	DATE: TXDOT
© TXDOT November 2002	CONT: 6442	SECT: 70	JOB: 001	HIGHWAY: US 96, ETC.
9-07 8-14	DIST: LFK	COUNTY: SABINE	SHEET NO.:	15
7-13 5-21				

DISCLAIMER: The use of this standard is governed by the Texas Engineering Practice Act. No warranty of any kind is made by the State of Texas for the use of this standard or for any incorrect results or damages resulting from its use.

DATE: 4/12/2023 7:22:50 AM
FILE: T:\LFKDMaint\Contractors\0-RMC - Routine Maintenance Contracts\123 Plans\6442-70-001 Sabine\00R-STD-BC-21.dgn

The use of this standard is governed by the "Texas Engineering Practice Act". No warranty of any kind is made by the State of Texas for the use of this standard for other purposes or for incorrect results or damages resulting from its use.
 DATE: 4/12/2023 7:22:51 AM
 FILE: T:\LFKDDM\mnt Contracts\0-RMC - Routine Maintenance Contracts\123 Plans\6442-70-001 Sabine\BGF_VGN\STD\BC-21.dgn

WORK ZONE PAVEMENT MARKINGS

GENERAL

- The Contractor shall be responsible for maintaining work zone and existing pavement markings, in accordance with the standard specifications and special provisions, on all roadways open to traffic within the CSJ limits unless otherwise stated in the plans.
- Color, patterns and dimensions shall be in conformance with the "Texas Manual on Uniform Traffic Control Devices" (TMUTCD).
- Additional supplemental pavement marking details may be found in the plans or specifications.
- Pavement markings shall be installed in accordance with the TMUTCD and as shown on the plans.
- When short term markings are required on the plans, short term markings shall conform with the TMUTCD, the plans and details as shown on the Standard Plan Sheet WZ(SIPM).
- When standard pavement markings are not in place and the roadway is opened to traffic, DO NOT PASS signs shall be erected to mark the beginning of the sections where passing is prohibited and PASS WITH CARE signs at the beginning of sections where passing is permitted.
- All work zone pavement markings shall be installed in accordance with Item 662, "Work Zone Pavement Markings."

RAISED PAVEMENT MARKERS

- Raised pavement markers are to be placed according to the patterns on BC(1)2.
- All raised pavement markers used for work zone markings shall meet the requirements of Item 672, "RAISED PAVEMENT MARKERS" and Departmental Material Specification DMS-4200 or DMS-4300.

PREFABRICATED PAVEMENT MARKINGS

- Removable prefabricated pavement markings shall meet the requirements of DMS-8241.
- Non-removable prefabricated pavement markings (foil back) shall meet the requirements of DMS-8240.

MAINTAINING WORK ZONE PAVEMENT MARKINGS

- The Contractor will be responsible for maintaining work zone pavement markings within the work limits.
- Work zone pavement markings shall be inspected in accordance with the frequency and reporting requirements of work zone traffic control device inspections as required by Form 599.
- The markings should provide a visible reference for a minimum distance of 300 feet during normal daylight hours and 160 feet when illuminated by automobile low-beam headlights at night, unless sight distance is restricted by roadway geometrics.
- Markings failing to meet this criteria within the first 30 days after placement shall be replaced at the expense of the Contractor as per Specification Item 662.

REMOVAL OF PAVEMENT MARKINGS

- Pavement markings that are no longer applicable, could create confusion or direct a motorist toward or into the closed portion of the roadway shall be removed or obliterated before the roadway is opened to traffic.
- The above shall not apply to detours in place for less than three days, where flaggers and/or sufficient channelizing devices are used in lieu of markings to outline the detour route.
- Pavement markings shall be removed to the fullest extent possible, so as not to leave a discernable marking. This shall be by any method approved by TxDOT Specification Item 677 for "Eliminating Existing Pavement Markings and Markers".
- The removal of pavement markings may require resurfacing or seal coating portions of the roadway as described in Item 677.
- Subject to the approval of the Engineer, any method that proves to be successful on a particular type pavement may be used.
- Blast cleaning may be used but will not be required unless specifically shown in the plans.
- Over-painting of the markings SHALL NOT BE permitted.
- Removal of raised pavement markers shall be as directed by the Engineer.
- Removal of existing pavement markings and markers will be paid for directly in accordance with Item 677, "ELIMINATING EXISTING PAVEMENT MARKINGS AND MARKERS," unless otherwise stated in the plans.
- Black-out marking tape may be used to cover conflicting existing markings for periods less than two weeks when approved by the Engineer.

Temporary Flexible-Reflective Roadway Marker Tabs

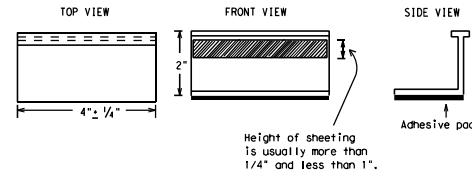

**STAPLES OR NAILS SHALL NOT BE USED TO SECURE
TEMPORARY FLEXIBLE-REFLECTIVE ROADWAY MARKER
TABS TO THE PAVEMENT SURFACE**

- Temporary flexible-reflective roadway marker tabs used as guidemarks shall meet the requirements of DMS-8242.
- Tabs detailed on this sheet are to be inspected and accepted by the Engineer or designated representative. Sampling and testing is not normally required, however at the option of the Engineer, either "A" or "B" below may be imposed to assure quality before placement on the roadway.
 - Select five (5) or more tabs at random from each lot or shipment and submit to the Construction Division, Materials and Pavement Section to determine specification compliance.
 - Select five (5) tabs and perform the following test. Affix five (5) tabs at 24 inch intervals on an asphaltic pavement in a straight line. Using a medium size passenger vehicle or pickup, run over the markers with the front and rear tires at a speed of 35 to 40 miles per hour, four (4) times in each direction. No more than one (1) out of the five (5) reflective surfaces shall be lost or displaced as a result of this test.
- Small design variances may be noted between tab manufacturers.
- See Standard Sheet WZ(SIPM) for tab placement on new pavements. See Standard Sheet TCP(7-1) for tab placement on seal coat work.

RAISED PAVEMENT MARKERS USED AS GUIDEMARKS

- Raised pavement markers used as guidemarks shall be from the approved product list, and meet the requirements of DMS-4200.
- All temporary construction raised pavement markers provided on a project shall be of the same manufacturer.
- Adhesive for guidemarks shall be bituminous material hot applied or butyl rubber pad for all surfaces, or thermoplastic for concrete surfaces.

Guidemarks shall be designated as:
 YELLOW - (two amber reflective surfaces with yellow body).
 WHITE - (one silver reflective surface with white body).

DEPARTMENTAL MATERIAL SPECIFICATIONS	
PAVEMENT MARKERS (REFLECTORIZED)	DMS-4200
TRAFFIC BUTTONS	DMS-4300
EPOXY AND ADHESIVES	DMS-6100
BITUMINOUS ADHESIVE FOR PAVEMENT MARKERS	DMS-6130
PERMANENT PREFABRICATED PAVEMENT MARKINGS	DMS-8240
TEMPORARY REMOVABLE, PREFABRICATED PAVEMENT MARKINGS	DMS-8241
TEMPORARY FLEXIBLE, REFLECTIVE ROADWAY MARKER TABS	DMS-8242

A list of prequalified reflective raised pavement markers, non-reflective traffic buttons, roadway marker tabs and other pavement markings can be found at the Material Producer List web address shown on BC(1).

SHEET 11 OF 12

 Texas Department of Transportation	Traffic Safety Division Standard
<h2 style="margin: 0;">BARRICADE AND CONSTRUCTION PAVEMENT MARKINGS</h2> <h3 style="margin: 0;">BC(1) - 21</h3>	
FILE: bc-21.dgn © TxDOT February 1998	DWS: TxDOT CONT: 6442 SECT: 70 JOB: 001 US 96, ETC. DIST: LFK COUNTY: SABINE SHEET NO.: 16

PAVEMENT MARKING PATTERNS

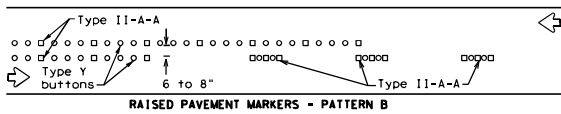
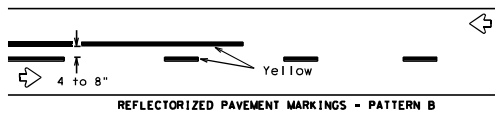
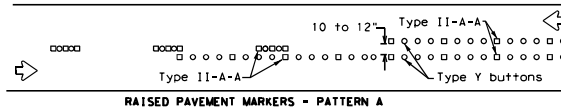
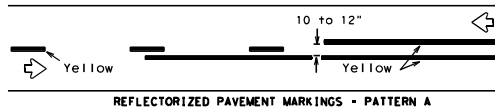

Pattern A is the TXDOT Standard, however Pattern B may be used if approved by the Engineer. Prefabricated markings may be substituted for reflectORIZED pavement markings.

CENTER LINE & NO-PASSING ZONE BARRIER LINES FOR TWO-LANE, TWO-WAY HIGHWAYS

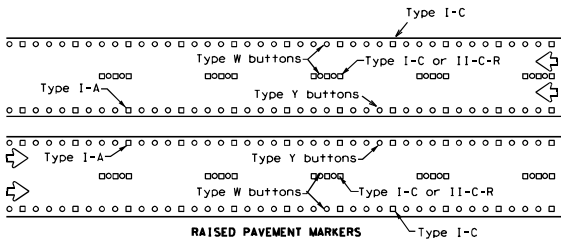
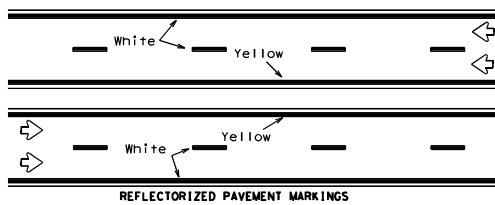

Prefabricated markings may be substituted for reflectORIZED pavement markings.

EDGE & LANE LINES FOR DIVIDED HIGHWAY

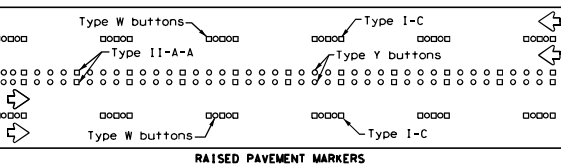
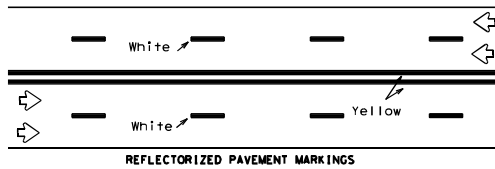

Prefabricated markings may be substituted for reflectORIZED pavement markings.

LANE & CENTER LINES FOR MULTILANE UNDIVIDED HIGHWAYS

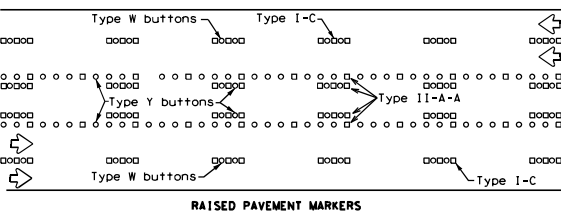
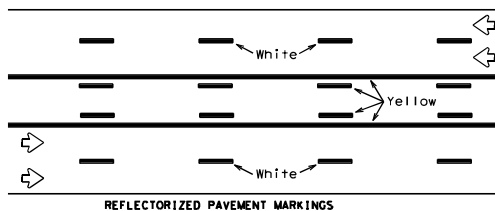

Prefabricated markings may be substituted for reflectORIZED pavement markings.

TWO-WAY LEFT TURN LANE

STANDARD WORK ZONE PAVEMENT MARKINGS DETAILS

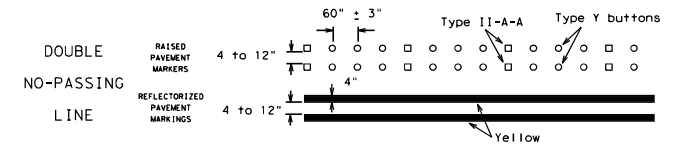

SOLID LINES

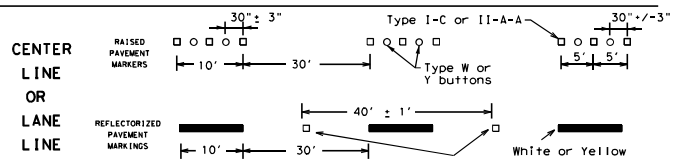
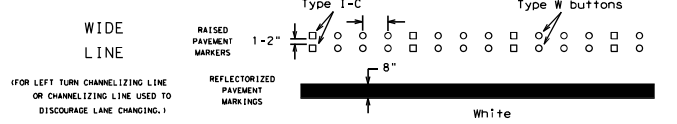
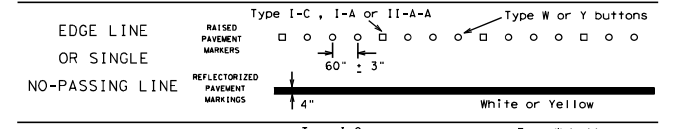

BROKEN LINES

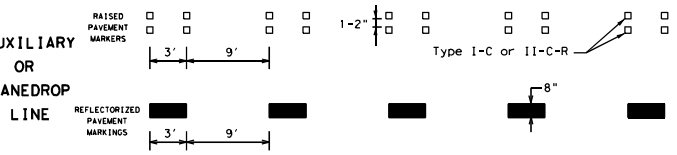

REMOVABLE MARKINGS WITH RAISED PAVEMENT MARKERS

If raised pavement markers are used to supplement REMOVABLE markings, the markers shall be applied to the top of the tape at the approximate mid length of tape used for broken lines or at 20 foot spacing for solid lines. This allows an easier removal of raised pavement markers and tape.

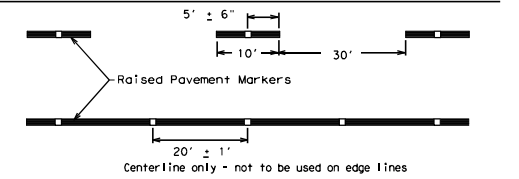

BARRICADE AND CONSTRUCTION PAVEMENT MARKING PATTERNS

BC (12) - 21

Raised pavement markers used as standard pavement markings shall be from the approved products list and meet the requirements of Item 672 "RAISED PAVEMENT MARKERS."

FILE: bc-21.dgn	DATE: TxDOT February 1998	REV: 6442	JOB: 001	US 96, ETC.
DATE: 4/12/2023 7:22:52 AM	FILE: T:\LFKDMaint Contracts\0-RMC - Routine Maintenance Contracts\123 Plans\6442-70-001 Sabine MGR-VGN-STD-BC-21.dgn	REV: 2-98 7-13	COUNTY: LFK	SHEET NO: 17
DATE: 11-02 8-14	FILE: T\LFKDMaint Contracts\0-RMC - Routine Maintenance Contracts\123 Plans\6442-70-001 Sabine MGR-VGN-STD-BC-21.dgn	REV: 11-02 8-14	COUNTY: LFK	SHEET NO: 17

DISCLAIMER: The use of this standard is governed by the Texas Engineering Practice Act. No warranty of any kind is made by the author of this standard or by the publisher for any incorrect results or damages resulting from its use.

DATE: 4/12/2023 7:22:52 AM
FILE: T:\LFKDMaint Contracts\0-RMC - Routine Maintenance Contracts\123 Plans\6442-70-001 Sabine MGR-VGN-STD-BC-21.dgn

DISCLAIMER:
The use of this standard is governed by the "Texas Engineering Practice Act". No warranty of any kind is made by TxDOT for any purpose whatsoever. TxDOT assumes no responsibility for the conversion or use of this standard in any way other than that intended by the Texas Department of Transportation.

DATE: 4/12/2023 7:22:53 AM
FILE: T:\LFK\DM\Main\Contract\0-RMC - Routine Maintenance\Contract\18-11667C815B2

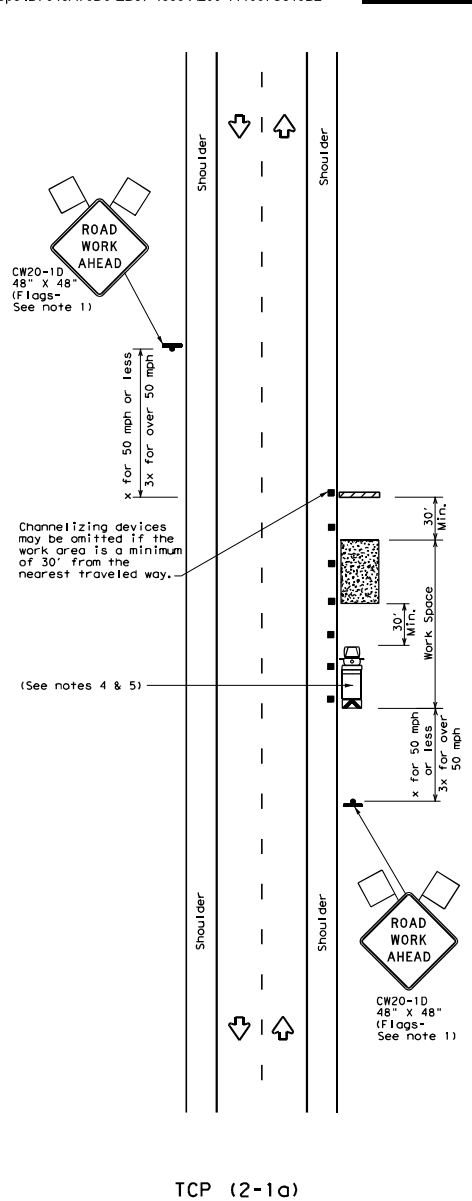

TCP (2-1a)

WORK SPACE NEAR SHOULDER
Conventional Roads

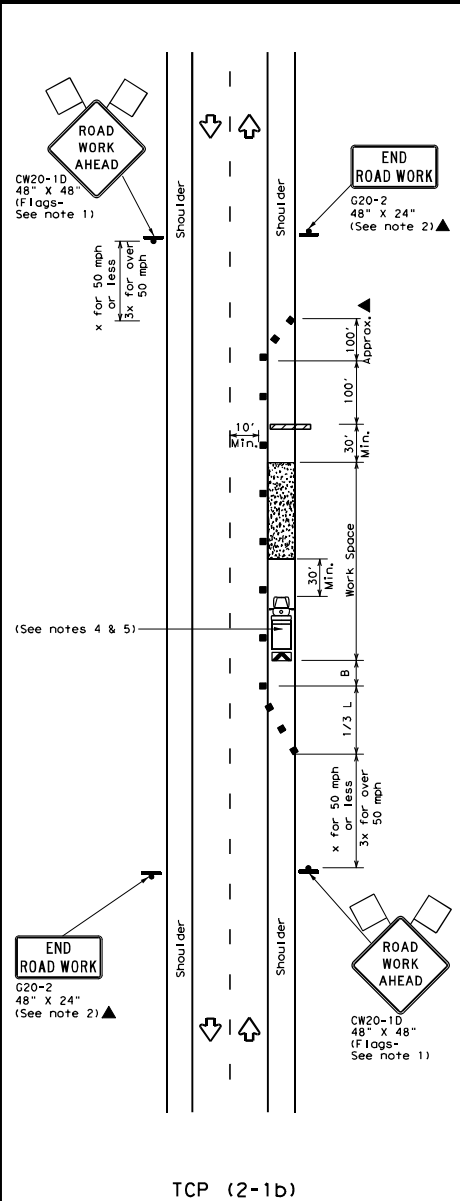

TCP (2-1b)

WORK SPACE ON SHOULDER
Conventional Roads

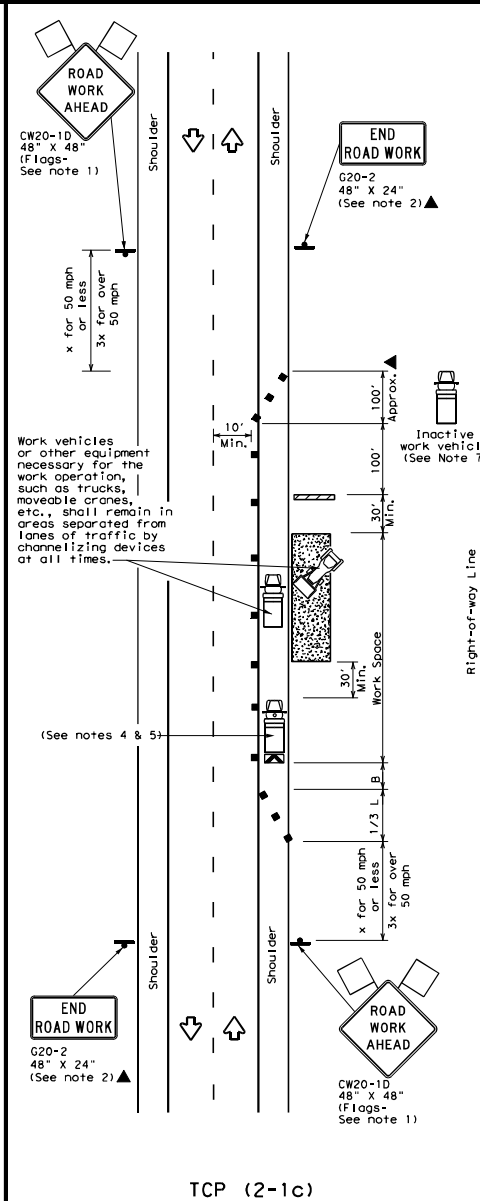

TCP (2-1c)

WORK VEHICLES ON SHOULDER
Conventional Roads

LEGEND			
	Type 3 Barricade		Channelizing Devices
	Heavy Work Vehicle		Truck Mounted Attenuator (TMA)
	Trailer Mounted Flashing Arrow Board		Portable Changeable Message Sign (PCMS)
	Sign		Traffic Flow
	Flag		Flagger

Posted Speed * *	Formula	Minimum Desirable Taper Lengths **			Suggested Maximum Spacing of Channelizing Devices		Minimum Sign Spacing Distance	Suggested Longitudinal Buffer Space * B'
		10' Offset	11' Offset	12' Offset	On a Taper	On a Tangent		
30	L = $\frac{WS^2}{60}$	150'	165'	180'	30'	60'	120'	90'
35		205'	225'	245'	35'	70'	160'	120'
40	L = WS	265'	295'	320'	40'	80'	240'	155'
45		450'	495'	540'	45'	90'	320'	195'
50	L = WS	500'	550'	600'	50'	100'	400'	240'
55		550'	605'	660'	55'	110'	500'	295'
60	L = WS	600'	660'	720'	60'	120'	600'	350'
65		650'	715'	780'	65'	130'	700'	410'
70	L = WS	700'	770'	840'	70'	140'	800'	475'
75		750'	825'	900'	75'	150'	900'	540'

* Conventional Roads Only
** Taper lengths have been rounded off.
L=Length of Taper (FT) W=Width of Offset (FT) S=Posted Speed (MPH)

TYPICAL USAGE			
MOBILE	SHORT DURATION	SHORT TERM STATIONARY	LONG TERM STATIONARY
	✓	✓	✓

- GENERAL NOTES**
- Flags attached to signs where shown, are REQUIRED.
 - All traffic control devices illustrated are REQUIRED, except those denoted with the triangle symbol may be omitted when stated in the plans, or for routine maintenance work, when approved by the Engineer.
 - Stockpiled material should be placed a minimum of 30 feet from nearest traveled way.
 - Shadow Vehicle with TMA and high intensity rotating, flashing, oscillating or strobe lights. A Shadow Vehicle with a TMA should be used anytime it can be positioned 30 to 100 feet in advance of the area of crew exposure without adversely affecting the performance or quality of the work. If workers are no longer present but road or work conditions require the traffic control to remain in place, Type 3 Barricades or other channelizing devices may be substituted for the Shadow Vehicle and TMA.
 - Additional Shadow Vehicles with TMAs may be positioned off the paved surface, next to those shown in order to protect a wider work space.
 - See TCP(5-1) for shoulder work on divided highways, expressways and freeways.
 - Inactive work vehicles or other equipment should be parked near the right-of-way line and not parked on the paved shoulder.
 - CW21-5 "SHOULDER WORK" signs may be used in place of CW20-1D "ROAD WORK AHEAD" signs for shoulder work on conventional roadways.

Texas Department of Transportation
Traffic Operations Division Standard

TRAFFIC CONTROL PLAN
CONVENTIONAL ROAD
SHOULDER WORK

TCP (2-1) - 18

FILE: tcp2-1-18.dgn	DATE: 12/18/95	BY: LFK	CHK: LFK	DATE: 12/18/95	CHK: LFK
© TxDOT	December 1985	CONT. SECT.	6442	70	JOB
2-94	4-98	REVISONS	6442	70	001
8-95	2-12	DIST	LFK	COUNTY	SABINE
1-97	2-18				SHEET NO. 18

DISCLAIMER: The use of this standard is governed by the "Texas Engineering Practice Act". No warranty of any kind is made by TxDOT for any purpose whatsoever. TxDOT assumes no responsibility for the conversion of units or the use of this standard in any manner other than that intended by the Texas Department of Transportation.

DATE: 4/12/2023 7:22:55 AM
 FILE: T:\LK\KDM\Int\Contr\act\0-RMC - Routine Maintenance Contracts\123 of Lights\Legend\CPA\TCP(2-3)18.dgn

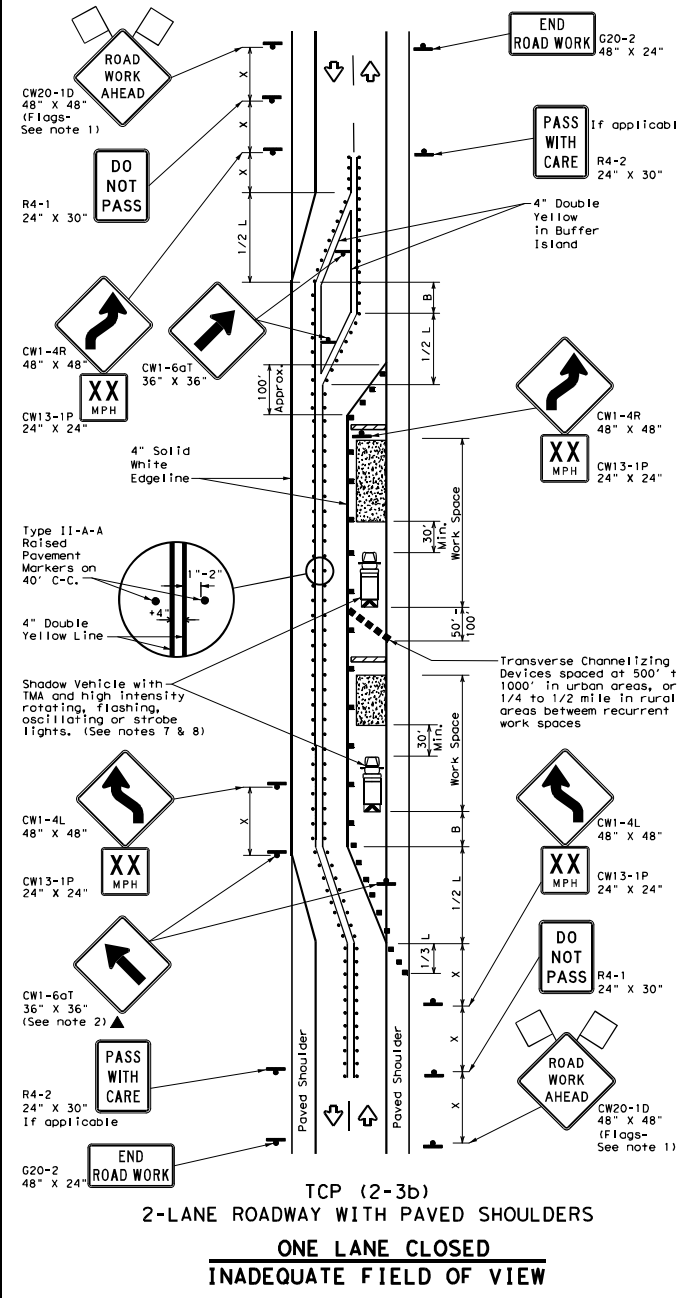
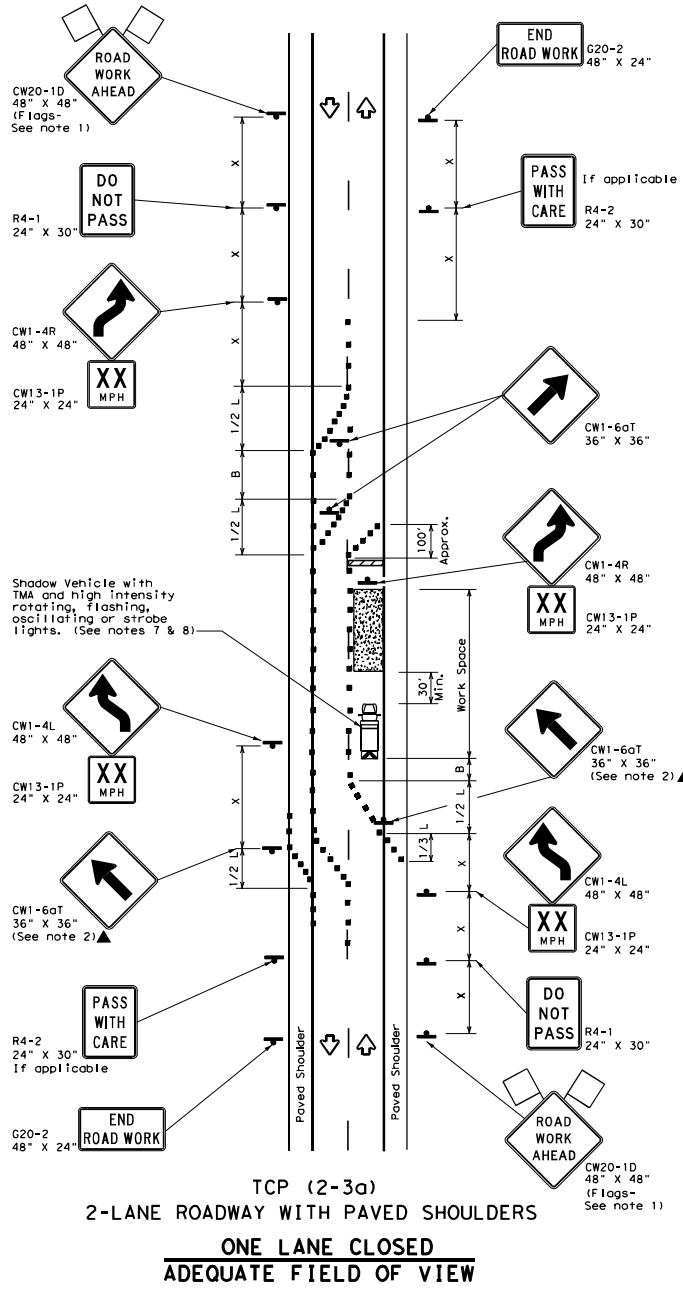

LEGEND			
	Type 3 Barricade		Channelizing Devices
	Heavy Work Vehicle		Truck Mounted Attenuator (TMA)
	Trailer Mounted Flashing Arrow Board		Raised Pavement Markers Ty II-AA
	Sign		Traffic Flow
	Flag		Flagger

Posted Speed * mph	Formula L = WS ² 60	Minimum Desirable Taper Lengths **			Suggested Maximum Spacing of Channelizing Devices		Minimum Sign Spacing Distance	Suggested Longitudinal Buffer Space "B"
		10' Offset	11' Offset	12' Offset	On a Taper	On a Tangent		
30		150'	165'	180'	30'	60'	120'	90'
35		205'	225'	245'	35'	70'	160'	120'
40		265'	295'	320'	40'	80'	240'	155'
45		450'	495'	540'	45'	90'	320'	195'
50		500'	550'	600'	50'	100'	400'	240'
55		550'	605'	660'	55'	110'	500'	295'
60		600'	660'	720'	60'	120'	600'	350'
65		650'	715'	780'	65'	130'	700'	410'
70		700'	770'	840'	70'	140'	800'	475'
75		750'	825'	900'	75'	150'	900'	540'

* Conventional Roads Only
 ** Taper Lengths have been rounded off.
 L=Length of Taper (FT) W=Width of Offset (FT) S=Posted Speed (MPH)

MOBILE	TYPICAL USAGE			
	SHORT DURATION	SHORT TERM STATIONARY	INTERMEDIATE TERM STATIONARY	LONG TERM STATIONARY
				TCP (2-3b) ONLY

- GENERAL NOTES**
- Flags attached to signs where shown, are REQUIRED.
 - All traffic control devices illustrated are REQUIRED, except those denoted with the triangle symbol may be omitted when stated elsewhere in the plans, or for routine maintenance work, when approved by the Engineer.
 - When work space will be in place less than three days existing pavement markings may remain in place. Channelizing devices shall be used to separate traffic.
 - Flagger control should NOT be used unless roadway conditions or heavy traffic volume require additional emphasis to safely control traffic. Flagger should be positioned at end of traffic queue.
 - The R4-1 "DO NOT PASS," R4-2 "PASS WITH CARE" and construction regulatory speed zone signs may be installed within CW20-1D "ROAD WORK AHEAD" signs. Proper spacing of signs shall be maintained.
 - Conflicting pavement marking shall be removed for long term projects.
 - A Shadow Vehicle with a TMA should be used anytime it can be positioned 30 to 100 feet in advance of the area of crew exposure without adversely affecting the performance or quality of the work. If workers are no longer present but road or work conditions require the traffic control to remain in place, Type 3 Barricades or other channelizing devices may be substituted.
 - Additional Shadow Vehicles with TMAs may be positioned off the paved surface, next to those shown in order to protect a wider work space.
- TCP (2-3a)**
- Conflicting pavement markings shall be removed for long-term projects. For shorter durations where traffic is directed over a yellow centerline, channelizing devices which separate two-way traffic should be spaced on tapers at 20' or 15' if posted speeds are 35 mph or slower, and for tangent sections, at 1/2(S) where S is the speed in mph. This tighter device spacing is intended for the area of the conflicting markings, not the entire work zone.

Texas Department of Transportation
 Traffic Operations Division Standard

TRAFFIC CONTROL PLAN
TRAFFIC SHIFTS ON
TWO-LANE ROADS

TCP (2-3)-18

FILE:	tcp(2-3)-18.dgn	DATE:	08/18/2018	BY:	CK1
© TxDOT	December 1985	CONT	SECT	JOB	HIGHWAY
8-95	3-01	6442	70	001	US 96, ETC.
1-97	2-12	DIST	COUNTY		SHEET NO.
4-98	2-18	LFK	SABINE		20

DISCLAIMER:
The use of this standard is governed by the "Texas Engineering Practice Act". No warranty of any kind is made by TxDOT for any purpose whatsoever. TxDOT assumes no responsibility for the conversion of this standard into a contract or for any damages resulting from its use.

DATE: 4/12/2023 7:22:56 AM
FILE: T:\LKFD\Main\Int\Contracts\O-RMC - Routine Maintenance Contracts\FY23\11667C815B2\Traffic Control Plans\TCP (2-4) - 18.dgn

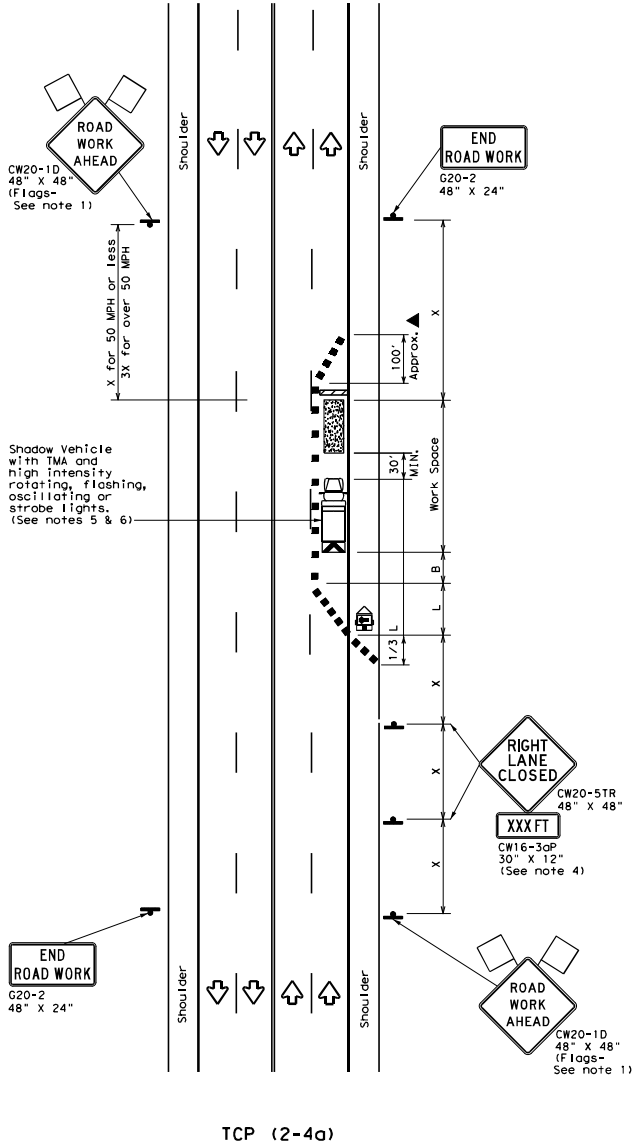

TCP (2-4a)
ONE LANE CLOSED

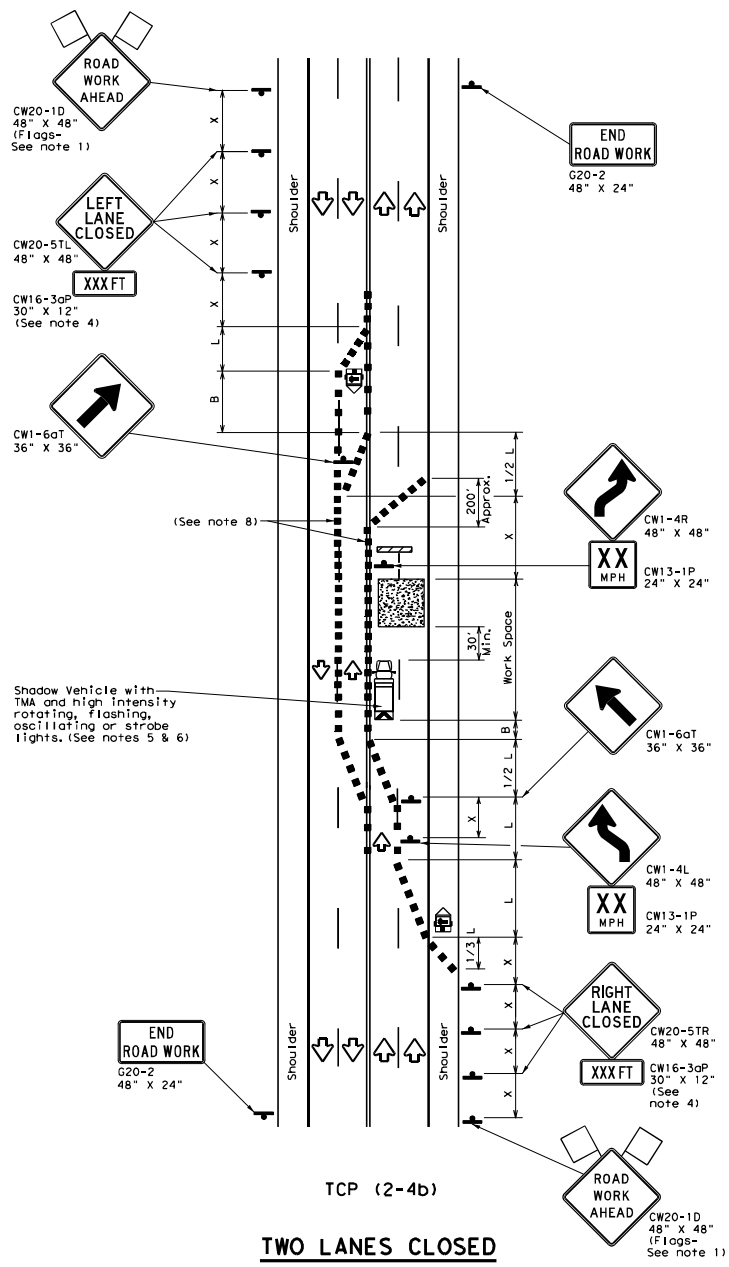

TCP (2-4b)
TWO LANES CLOSED

LEGEND			
	Type 3 Barricade		Channelizing Devices
	Heavy Work Vehicle		Truck Mounted Attenuator (TMA)
	Trailer Mounted Flashing Arrow Board		Portable Changeable Message Sign (PCMS)
	Sign		Traffic Flow
	Flag		Flagger

Posted Speed *	Formula	Minimum Desirable Taper Lengths * X			Suggested Maximum Spacing of Channelizing Devices		Minimum Sign Spacing * Distance	Suggested Longitudinal Buffer Space * "B"
		10' Offset	11' Offset	12' Offset	On a Taper	On a Tangent		
30	$L = \frac{WS^2}{60}$	150'	165'	180'	30'	60'	120'	90'
35		205'	225'	245'	35'	70'	160'	120'
40		265'	295'	320'	40'	80'	240'	155'
45		330'	365'	395'	45'	90'	320'	195'
50	L = WS	500'	550'	600'	50'	100'	400'	240'
55		550'	605'	660'	55'	110'	500'	295'
60		600'	660'	720'	60'	120'	600'	350'
65		650'	715'	780'	65'	130'	700'	410'
70		700'	770'	840'	70'	140'	800'	475'
75		750'	825'	900'	75'	150'	900'	540'

* Conventional Roads Only
** Taper lengths have been rounded off.
L=Length of Taper (FT) W=Width of Offset(FT) S=Posted Speed(MPH)

TYPICAL USAGE				
MOBILE	SHORT DURATION	SHORT TERM STATIONARY	INTERMEDIATE TERM STATIONARY	LONG TERM STATIONARY
		✓	✓	

- GENERAL NOTES**
- Flags attached to signs where shown, are REQUIRED.
 - All traffic control devices illustrated are REQUIRED, except those denoted with the triangle symbol may be omitted when stated elsewhere in the plans, or for routine maintenance work, when approved by the Engineer.
 - The downstream taper is optional. When used, it should be 100 feet minimum length per lane.
 - For short term applications, when post mounted signs are not used, the distance legend may be shown on the sign face rather than on a CW16-3AP supplemental plaque.
 - A Shadow Vehicle with a TMA should be used anytime it can be positioned 30 to 100 feet in advance of the area of crew exposure without adversely affecting the performance or quality of the work. If workers are no longer present but road or work conditions require the traffic control to remain in place, Type 3 Barricades or other channelizing devices may be substituted for the Shadow Vehicle and TMA.
 - Additional Shadow Vehicles with TMAs may be positioned in each closed lane, on the shoulder or off the paved surface, next to those shown in order to protect a wider work space.
- TCP (2-4a)**
- If this TCP is used for a left lane closure, CW20-5TL "LEFT LANE CLOSED" signs shall be used and channelizing devices shall be placed on the centerline to protect the work space from opposing traffic with the arrow board placed in the closed lane near the end of the merging taper.
- TCP (2-4b)**
- For shorter durations where traffic is directed over a yellow centerline, channelizing devices which separate two-way traffic should be spaced on tapers at 20' or 15' if posted speeds are 35 mph or slower, and for tangent sections, at 1/2(S) where S is the speed in mph. This tighter device spacing is intended for the area of conflicting markings, not the entire work zone.

		Traffic Operations Division Standard	
TRAFFIC CONTROL PLAN LANE CLOSURES ON MULTILANE CONVENTIONAL ROADS			
TCP (2-4) - 18			
FILE: tcp2-4-18.dgn	DATE: December 1985	CONTRACT NO: 6442	SECTION: 70
REVISIONS	JOB NO: 001	COUNTY: LFK	HIGHWAY: SABINE
8-95 3-01	1-97 2-12	SHEET NO. 21	
4-98 2-18			

DISCLAIMER: The use of this standard is governed by the "Texas Engineering Practice Act". No warranty of any kind is made by TxDOT for any purpose whatsoever. TxDOT assumes no responsibility for the conversion of flags or damages resulting from its use.

DATE: 4/12/2023 7:22:57 AM
 FILE: T:\LFK\DM\mnt\contracts\0-RMC - Routine Maintenance Contracts\1223\1223-11667C815B2.dgn

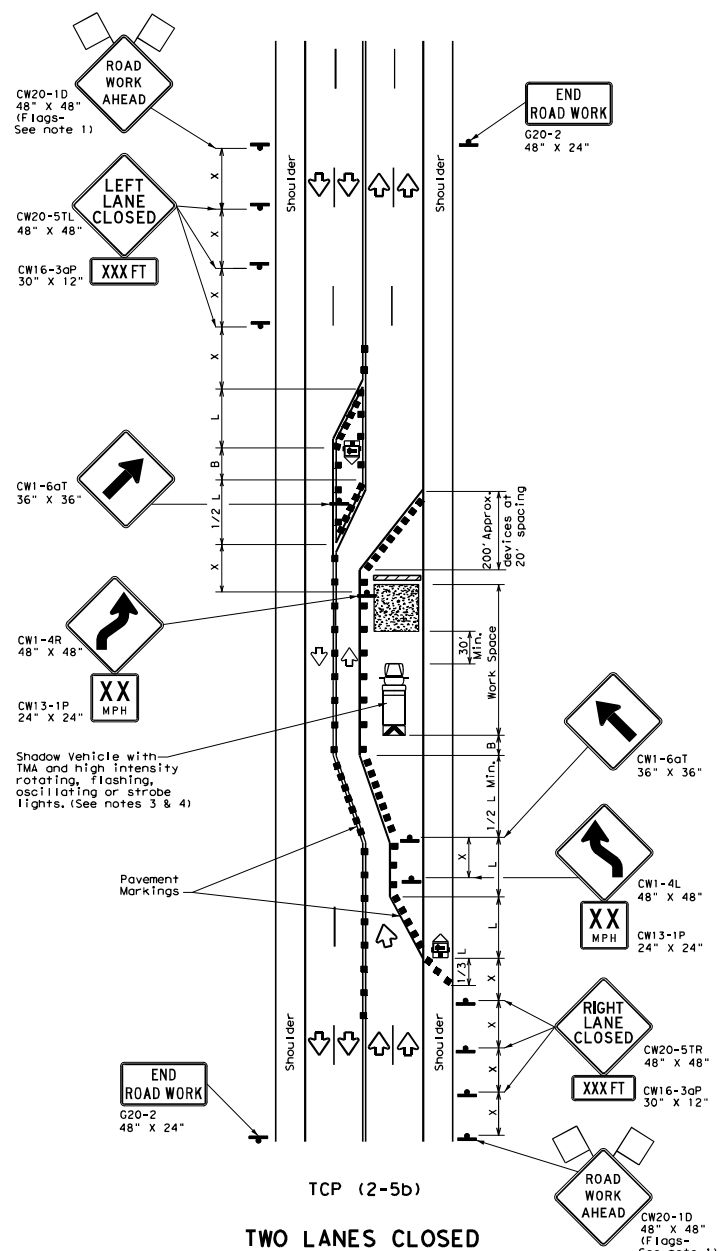
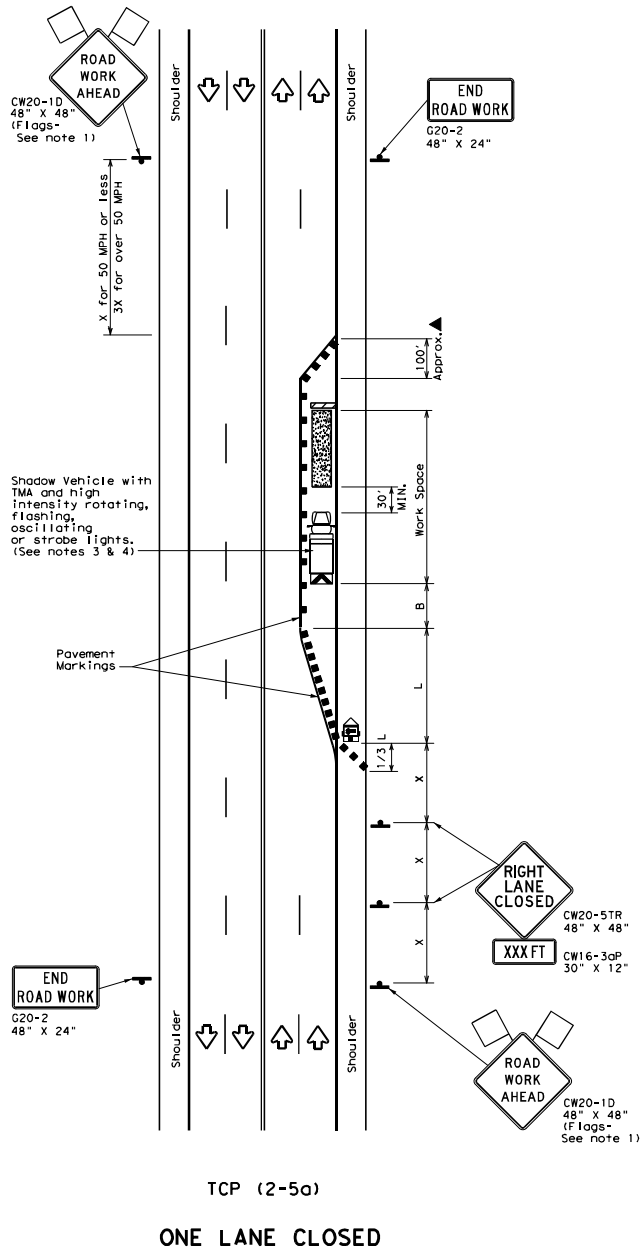

LEGEND			
	Type 3 Barricade		Channelizing Devices
	Heavy Work Vehicle		Truck Mounted Attenuator (TMA)
	Trailer Mounted Flashing Arrow Board		Portable Changeable Message Sign (PCMS)
	Sign		Traffic Flow
	Flag		Flagger

Posted Speed X	Formula	Minimum Desirable Taper Lengths			Suggested Maximum Spacing of Channelizing Devices		Minimum Sign Spacing "x" Distance	Suggested Longitudinal Buffer Space "B"
		10' Offset	11' Offset	12' Offset	On a Taper	On a Tangent		
30	L = WS ² / 60	150'	165'	180'	30'	60'	120'	90'
35		205'	225'	245'	35'	70'	160'	120'
40	L = WS	265'	295'	320'	40'	80'	240'	155'
45		450'	495'	540'	45'	90'	320'	195'
50	L = WS	500'	550'	600'	50'	100'	400'	240'
55		550'	605'	660'	55'	110'	500'	295'
60	L = WS	600'	660'	720'	60'	120'	600'	350'
65		650'	715'	780'	65'	130'	700'	410'
70	L = WS	700'	770'	840'	70'	140'	800'	475'
75		750'	825'	900'	75'	150'	900'	540'

* Conventional Roads Only
 ** Taper lengths have been rounded off.
 L=Length of Taper (FT) W=Width of Offset (FT) S=Posted Speed (MPH)

TYPICAL USAGE				
MOBILE	SHORT DURATION	SHORT TERM STATIONARY	INTERMEDIATE TERM STATIONARY	LONG TERM STATIONARY
			✓	✓

- GENERAL NOTES**
- Flags attached to signs where shown, are REQUIRED.
 - All traffic control devices illustrated are REQUIRED, except those denoted with the triangle symbol may be omitted when stated elsewhere in the plans, or for routine maintenance work, when approved by the Engineer.
 - A Shadow Vehicle with a TMA should be used anytime it can be positioned 30 to 100 feet in advance of the area of crew exposure without adversely affecting the performance or quality of the work. If workers are no longer present but road or work conditions require the traffic control to remain in place, Type 3 Barricades or other channelizing devices may be substituted for the Shadow Vehicle and TMA.
 - Additional Shadow Vehicles with TMAs may be positioned in each closed lane, on the shoulder or off the paved surface, next to those shown in order to protect a wider work space.
 - The downstream taper is optional. When used, it should be 100 feet approximately per lane, with channelizing devices spaced at 20 feet.
- TCP (2-5a)**
- If this TCP is used for a left lane closure, CW20-5TL "LEFT LANE CLOSED" signs shall be used and channelizing devices shall be placed on the centerline to protect the work space from opposing traffic, with the arrow board placed in the closed lane near the end of the merging taper.
- TCP (2-5b)**
- Conflicting pavement markings shall be removed for long-term projects.

Traffic Operations Division Standard

TRAFFIC CONTROL PLAN
 LONG TERM LANE CLOSURES
 MULTILANE CONVENTIONAL RDS.

TCP (2-5) - 18

FILE: tcp2-5-18.dgn	DATE: 12/01/1985	CONT: 6442	SECT: 70	JOB: 001	US: 96	ETC:
REVISIONS		DIST		COUNTY		SHEET NO.
8-95 2-12		1-97 3-03		4-98 2-18		22
LFK		SABINE				

DISCLAIMER: This is standard is covered by the "Texas Engineering Practice Act". No warranty of any kind is made by TxDOT for any purpose whatsoever. TxDOT assumes no responsibility for the conversion of this standard to other formats or for incorrect results or damages resulting from its use.

DATE: 4/12/2023
 FILE: T:\LFKDM\Main\ Contracts\0-RMC - Routine Maintenance Contracts\FY23 Plans\6442-70-001 Sabine MGF_VGN\STD\mbgf19.dgn

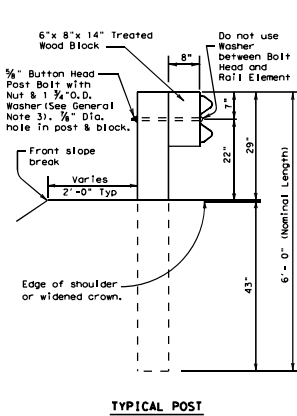

TYPICAL POST

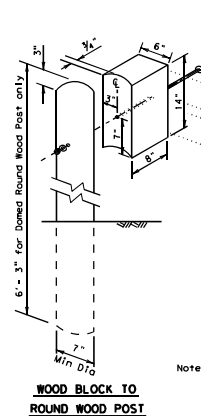

WOOD BLOCK TO RECTANGULAR WOOD POST

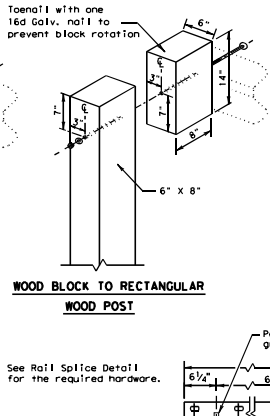

WOOD BLOCK TO STEEL POST

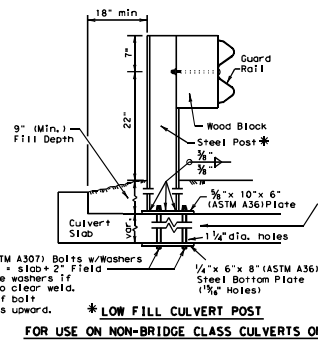

FOR USE ON NON-BRIDGE CLASS CULVERTS ONLY

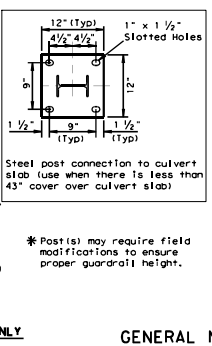

RAIL SPLICE DETAIL

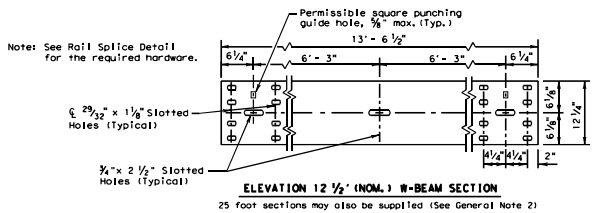

ELEVATION 12 1/2" (NOM.) W-BEAM SECTION

25 foot sections may also be supplied (See General Note 2)

GENERAL NOTES

- The type of post (round wood post, rectangular wood post, or steel post) will be shown elsewhere in the plans. The exact position of MBEF shall be shown elsewhere in the plans or as directed by the Engineer. Steel posts to be galvanized in accordance with Item 445, "Galvanizing."
- Rail element shall meet the requirements of Item 540, "Metal Beam Guard Fence" except as modified on the plans. The Contractor may furnish rail elements of 12 1/2 or 25 foot nominal lengths.
- Button head "post" bolts (ASTM A307) shall be of sufficient length to extend through the full thickness of the nut (ASTM A563) and Type A (1 3/4" O.D.) washer and not more than 1" beyond it. Button head "splice" bolts (ASTM A307) are 3/4" x 1 1/4" (or 2" long at triple rail splices) with a 3/8" double recessed nut (ASTM A563).
- Fittings (bolts, nuts, and washers) shall be galvanized in accordance with Item 445, "Galvanizing." Fittings shall be subsidiary to the bid item.
- Crown shall be widened to accommodate the Metal Beam Guard Fence.
- The lateral approach to the guard fence, shall have a slope rate of not more than 1V:10H.
- Unless otherwise shown in the plans, guard fence placed in the vicinity of curbs shall be positioned so that the face of curb is located directly below or behind the face of the block. Rail placed over curbs shall be installed so that the post bolt is located approximately 21 inches above the gutter pan or roadway surface.
- If solid rock is encountered within 0 to 18" of the finished grade, drill a 22" dia. hole, 24" into the rock, or drill two 12" dia. front to back overlapping holes, 24" into the rock. If solid rock is encountered below 18", drill a 12" dia. hole, 12" into the rock or to the standard embedment depth, whichever is less. Any excess post length, after meeting these depths, may be field cut to ensure proper guardrail mounting height. Backfill with a cohesionless material.
- Posts shall not be set in concrete, of any depth.
- Special fabrication will be required at installations having a curvature of less than 150 ft. radius.
- The terminal anchor section (TAS) post shall be set in Class A concrete (unless otherwise shown in the plans) in accordance with Item 421, "Hydraulic Cement Concrete." Concrete shall be subsidiary to the bid item requiring construction of the terminal anchor section (TAS). Terminal anchor post to be galvanized in accordance with Item 445, "Galvanizing."
- Unless otherwise shown in the plans, a composite material post and/or block that meets the requirements of DMS-7210, "Composite Material Posts and Blocks for Metal Beam Guard Fence" may be substituted for posts and/or blocks of similar dimensions. The Construction Division, TxDOT maintains a Material Producer List (MPL) for producers of materials conforming to DMS-7210. Only producers on the MPL can furnish composite material posts and/or blocks.

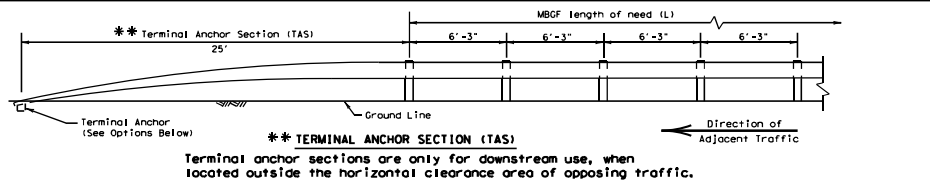

**** TERMINAL ANCHOR SECTION (TAS)**

Terminal anchor sections are only for downstream use, when located outside the horizontal clearance area of opposing traffic.

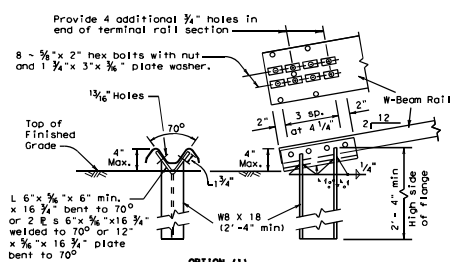

OPTION 11

Note: This anchor post requires four additional 3/4" holes (shop or field) in the rail member with eight 3/4" hex bolts with nut and plate washer.

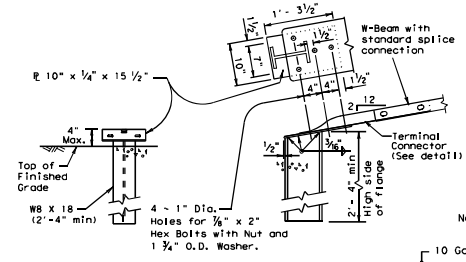

OPTION 12

Note: This anchor post requires the use of the 10 ga. terminal connector with four 3/4" hex bolts with nut and washer.

TERMINAL ANCHOR POST OPTIONS

(See General Note 11)

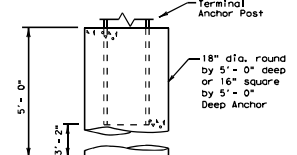

Notes:

Either concrete anchor may be used with either post option above. No construction joint is allowed in the concrete anchor. Terminal rail may be bolted to post and in twist position prior to placing concrete anchor. If concrete anchor is precast, the area should be compacted as directed by the Engineer, when placed in the field.

TERMINAL CONCRETE ANCHOR OPTIONS

(See General Note 11)

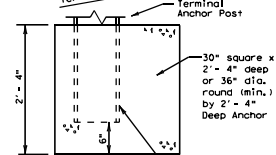

TERMINAL CONNECTOR

For connection hardware to concrete rails, see the MBEF transition standards.

ONLY FOR USE IN MAINTENANCE REPAIRS OR HIGHLY CONSTRAINED SITE CONDITIONS.

		Design Division Standard		
<h2>METAL BEAM GUARD FENCE</h2> <h3>MBGF - 19</h3>				
FILE: mbgf19.dgn	DN: TxDOT	CK: KM	DN: BD	CK: VP
REVISIONS	6442	70	001	US 96, ETC.
	DIST	COUNTY	SABINE	SHEET NO. 25

DISCUSS MFR. THIS STANDARD IS COVERED BY THE "TEXAS ENGINEERING PRACTICE ACT". NO WARRANTY OF ANY KIND IS MADE BY TxDOT FOR ANY PURPOSE WHATSOEVER. TxDOT ASSUMES NO RESPONSIBILITY FOR THE CONVERSION OF THIS STANDARD TO OTHER FORMATS OR FOR INCORRECT RESULTS OR DAMAGES RESULTING FROM ITS USE.

DATE: 4/12/2023
 FILE: T:\LFK\DM\mnt\contracts\0-RMC - Routine Maintenance Contracts\1923 Plans\6442-70-001 Sabine MBGF\03\STD\mbgfr19.dgn

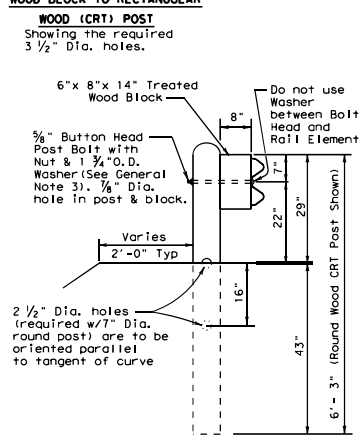
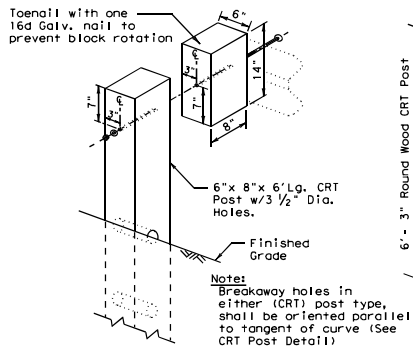

(CRT) POST DETAIL CONTROLLED RELEASE TERMINAL POST

Two or more wood CRT post(s) are required at any radius installation located at intersecting roadways or driveways.

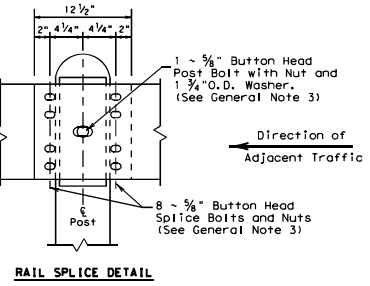
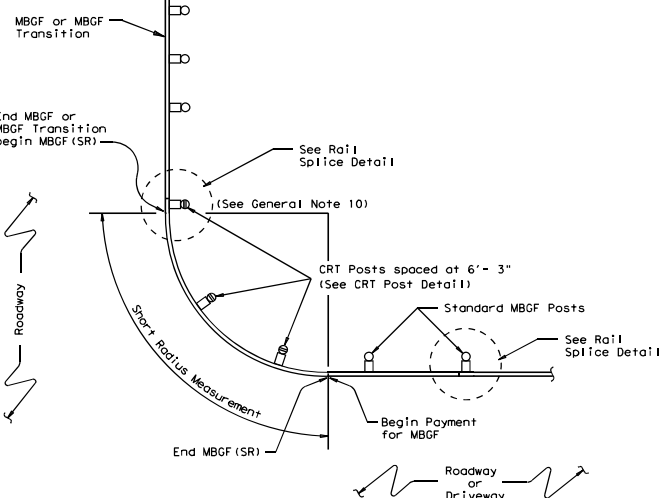
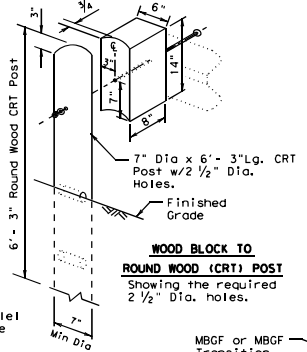

GENERAL NOTES

- The type of (CRT) post (round wood post, or rectangular wood post) will be shown elsewhere in the plans. The exact position of MBGF shall be shown elsewhere in the plans or as directed by the Engineer.
- Steel posts are not permitted at CRT post positions.
- Rail element shall meet the requirements of Item 540, "Metal Beam Guard Fence" except as modified on the plans. The Contractor may furnish rail elements of 12 1/2 or 25 foot nominal lengths.
- Button head "post" bolts (ASTM A307) shall be of sufficient length to extend through the full thickness of the nut (ASTM A563) and Type A (1 3/4" O.D.) washer and not more than 1" beyond it. Button head "splice" bolts (ASTM A307) are 5/8" x 1 1/4" (or 2" long at triple rail splices) with a 5/8" double recessed nut (ASTM A563).
- Fittings (bolts, nuts, and washers) shall be galvanized in accordance with Item 445, "Galvanizing." Fittings shall be subsidiary to the bid item.
- Crown shall be widened to accommodate the Metal Beam Guard Fence.
- The lateral approach to the guard fence, shall have a slope rate of not more than 1V:10H.
- Unless otherwise shown in the plans, guard fence placed in the vicinity of curbs shall be positioned so that the face of curb is located directly below or behind the face of the block. Rail placed over curbs shall be installed so that the post bolt is located approximately 21 inches above the gutter pan or roadway surface.
- If solid rock is encountered within 0 to 18" of the finished grade, drill a 22" dia. hole, 24" into the rock, or drill two 12" dia. front to back overlapping holes, 24" into the rock. If solid rock is encountered below 18", drill a 12" dia. hole, 12" into the rock or to the standard embedment depth, whichever is less. Any excess post length, after meeting these depths, may be field cut to ensure proper guardrail mounting height. Backfill with a cohesionless material.
- Guardrail posts shall not be set in concrete, of any depth.
- Special rail fabrication will be required at installations having a curvature of less than 150 ft. radius. The required radius shall be shown on the plans.
- The terminal anchor section (TAS) post shall be set in Class A concrete (unless otherwise shown in the plans) in accordance with Item 421, "Hydraulic Cement Concrete." Concrete shall be subsidiary to the bid item requiring construction of the terminal anchor section (TAS). Terminal anchor post to be galvanized in accordance with Item 445, "Galvanizing."
- Unless otherwise shown in the plans, a composite material post and/or block that meets the requirements of DMS-7210, "Composite Material Posts and Blocks for Metal Beam Guard Fence" may be substituted for posts and/or blocks of similar dimensions. The Construction Division, TxDOT maintains a Material Producer List (MPL) for producers of materials conforming to DMS-7210. Only producers on the MPL can furnish composite material posts and/or blocks.

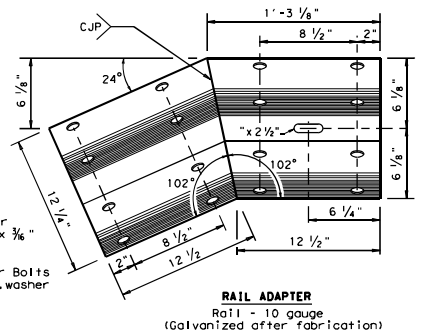
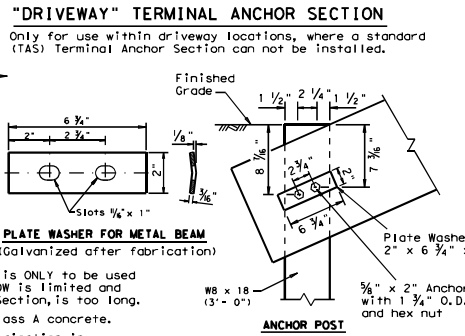
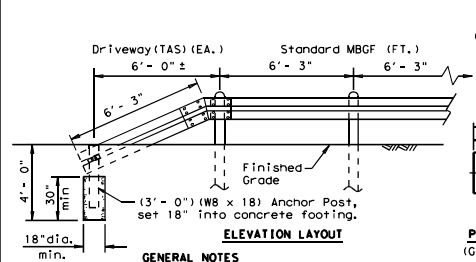

ONLY FOR USE IN MAINTENANCE REPAIRS OR HIGHLY CONSTRAINED SITE CONDITIONS.

Texas Department of Transportation
Design Division Standard

METAL BEAM GUARD FENCE (SHORT RADIUS) MBGF (SR) - 19

FILE: mbgfr19.dgn	DN: TxDOT	CR: KM	DM: BD	CK: VP
© TxDOT NOVEMBER 2019	CONT: 6442	SECT: 70	JOB: 001	HIGHWAY: US 96, ETC.
REVISIONS	DIST: LFK	COUNTY: SABINE	SHEET NO. 26	

DISCUSS W/CR. THIS STANDARD IS COVERED BY THE "TEXAS ENGINEERING PRACTICE ACT". NO WARRANTY OF ANY KIND IS MADE BY TxDOT FOR ANY PURPOSE WHATSOEVER. TxDOT ASSUMES NO RESPONSIBILITY FOR THE CONVERSION OF THIS STANDARD TO OTHER FORMATS OR FOR INCORRECT RESULTS OR DAMAGES RESULTING FROM ITS USE.
 DATE: 4/12/2023
 FILE: T:\LFK\DM\Main\Contract\10-RMC - Routine Maintenance Contracts\1023 Plans\6442-70-001 Sabine MBGF_VGN\STD\mbgff101019.dgn

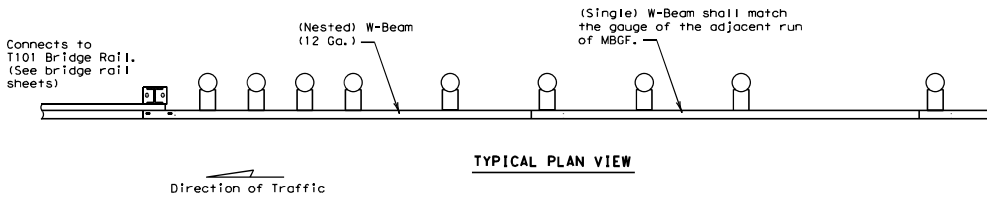

TYPICAL PLAN VIEW

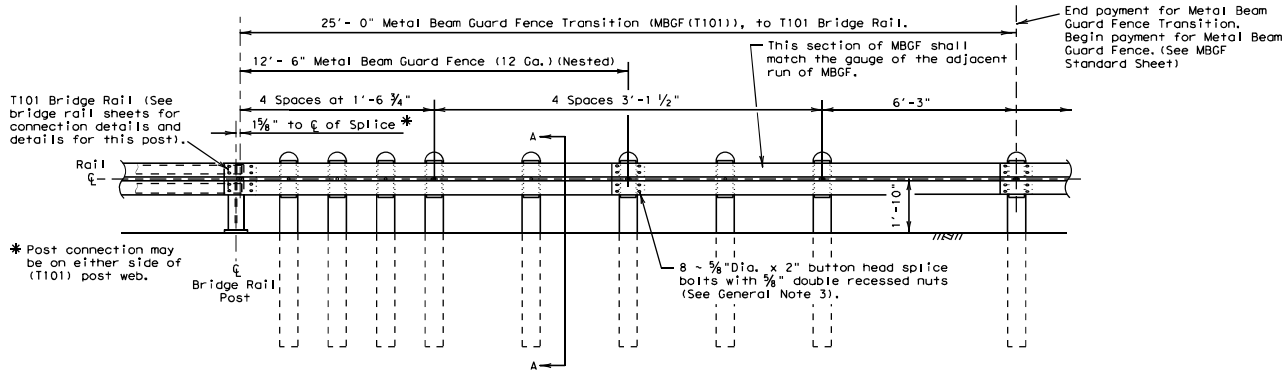

TYPICAL ELEVATION VIEW

* Post connection may be on either side of (T101) post web.

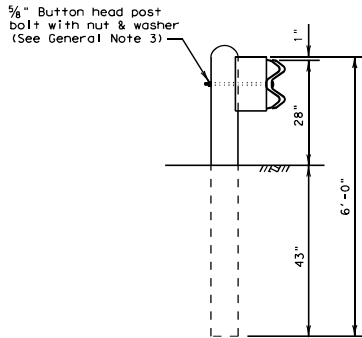

SECTION A-A

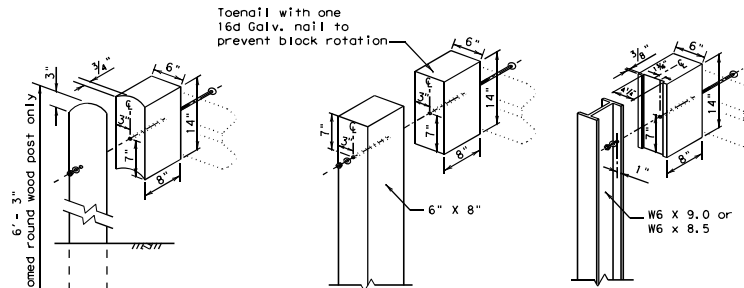

WOOD BLOCK TO RECTANGULAR WOOD POST

WOOD BLOCK TO STEEL POST

WOOD BLOCK TO ROUND WOOD POST

GENERAL NOTES

- The type of post (round wood post, rectangular wood post, or steel post) will be shown elsewhere in the plans. The exact position of transitions shall be shown elsewhere in the plans or as directed by the Engineer.
- Rail element shall meet the requirements of Item 540, "Metal Beam Guard Fence" except as modified on the plans.
- Button head "post" bolts (ASTM A307) shall be of sufficient length to extend through the full thickness of the nut (ASTM A563) and the Type A 1 1/4" O.D. washer and not more than 1" beyond it. Button head "splice" bolts (ASTM A307) are 5/8" x 2" (at triple rail splices) with a 3/8" double recessed nuts (ASTM A563).
- Fittings (bolts, nuts, and washers) shall be galvanized in accordance with Item 445, "Galvanizing." Fittings shall be subsidiary to the bid item requiring construction of the transition.
- Crown will be widened to accommodate transitions.
- If solid rock is encountered. See the MBGF standard sheet for proper installation guidance.
- Posts shall not be set in concrete.
- Unless otherwise shown in the plans, a composite material post and/or block that meets the requirements of DMS-7210, "Composite Material Posts and Blocks for Metal Beam Guard Fence" may be substituted for posts and/or blocks of similar dimensions. The Construction Division, TxDOT, maintains a Material Producer List (MPL) for producers of materials conforming to DMS-7210. Only producers on the MPL can furnish composite material posts and/or blocks.
- Refer to MBGF Standard Sheet for additional details.

ONLY FOR USE IN MAINTENANCE REPAIRS.

				Design Division Standard	
METAL BEAM GUARD FENCE TRANSITION (T101) (T101 BRIDGE RAIL) MBGF (T101)-19					
FILE: mbgff101019.dgn	DN: TxDOT	CR: KM	DR: BD	CK: VP	
© TxDOT NOVEMBER 2019	CONT	SECT	JOB	HIGHWAY	
REVISIONS	6442	70	001	US 96, ETC.	
	DIST	COUNTY		SHEET NO.	
	LFK	SABINE		27	

DISCUSS MGF - THIS STANDARD IS GOVERNED BY THE "TEXAS ENGINEERING PRACTICE ACT" - NO WARRANTY OF ANY KIND IS MADE BY TxDOT FOR ANY PURPOSE WHATSOEVER. TxDOT ASSUMES NO RESPONSIBILITY FOR THE CONVERSION OF THIS STANDARD TO OTHER FORMATS OR FOR INCORRECT RESULTS OR DAMAGES RESULTING FROM ITS USE.

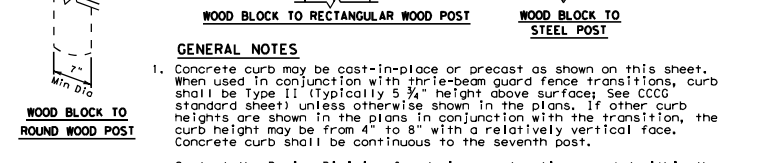
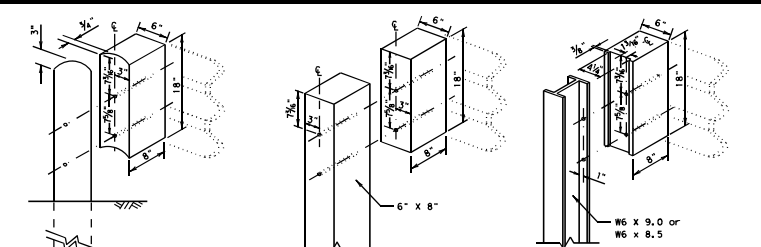
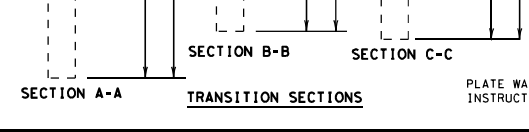
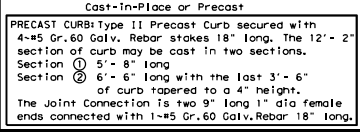
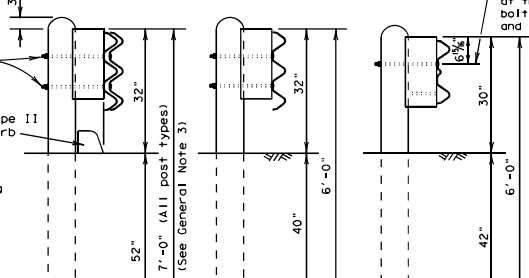
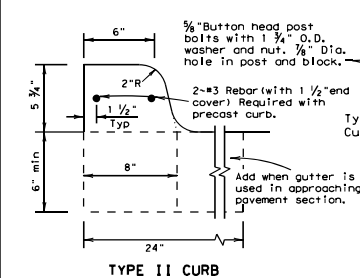
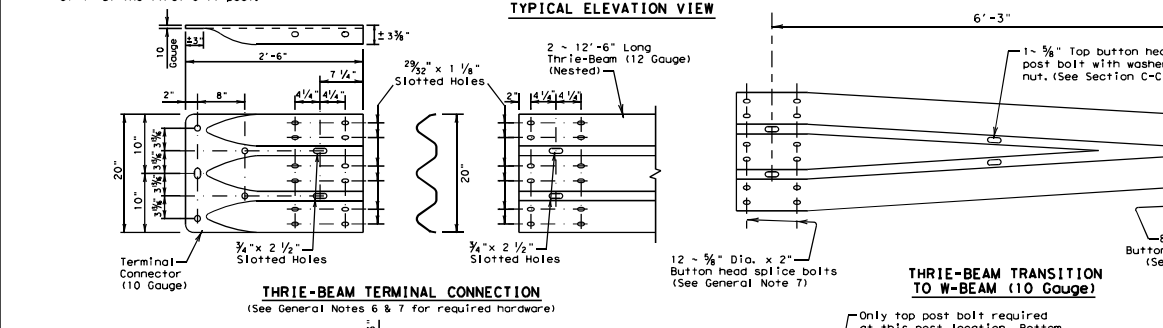
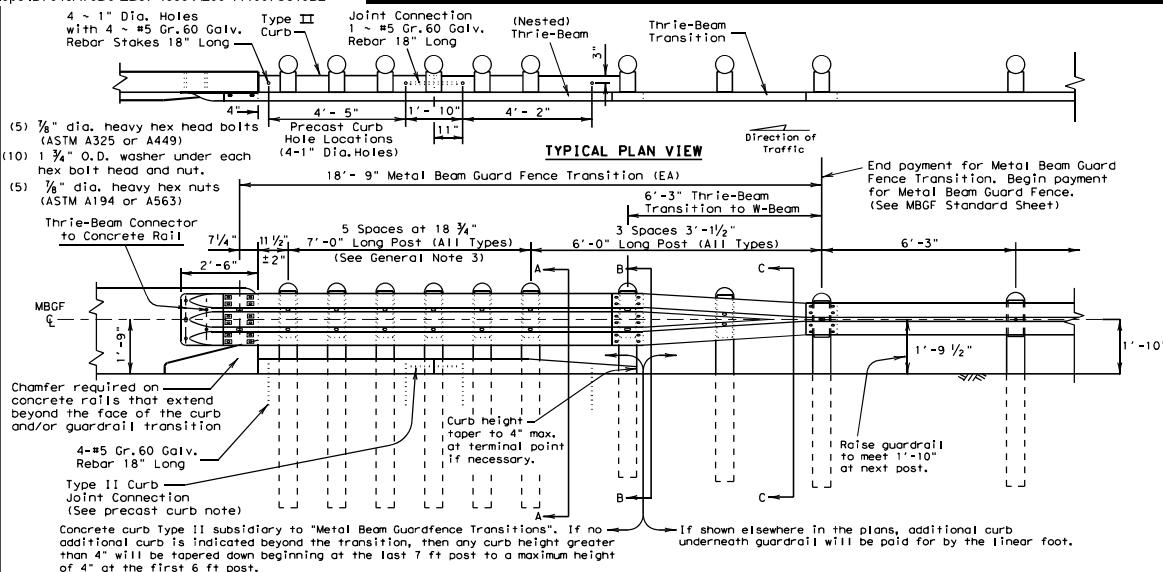

- GENERAL NOTES**
- Concrete curb may be cast-in-place or precast as shown on this sheet. When used in conjunction with thrie-beam guard fence transitions, curb shall be Type II (Typically 5 3/4" height above surface; See CCCC standard sheet) unless otherwise shown in the plans. If other curb heights are shown in the plans in conjunction with the transition, the curb height may be from 4" to 8" with a relatively vertical face. Concrete curb shall be continuous to the seventh post.
 - Contact the Design Division for drainage cut options needed within the curb section of the transition.
 - The type of post (round wood, rectangular wood or steel) will be shown elsewhere in the plans.
 - The post length shall be marked on all 7'-0" long posts by the Manufacturer. The mark shall be located within the top 1 ft. region of the post, at least 3/8" in height, and visible after installation. Wooden posts shall be marked with a brand, and steel posts with a stencil before galvanizing.
 - Rail element shall meet the requirements of Item 540, "Metal Beam Guard Fence" except as modified on the plans. The thrie-beam terminal connector and the thrie-beam transition to w-beam shall be of the same material, but shall not be less than 10 gauge.
 - Contractor shall verify that the locations of bolt holes match those in the thrie-beam terminal connector prior to ordering materials.
 - Unless otherwise shown in the plans, transitions shall be placed with the block face in front of or directly above the curb face.
 - Install terminal connector with (12) rectangular guardrail plate washers (FWR03) and (12) 3/8" x 2" button head splice bolts with recessed nuts.
 - Button head "post bolts & nuts" shall meet the requirements of (ASTM A307), and shall be of sufficient length to extend through the full thickness of the nut and 3/8" washer (FWC16a) and not more than 1" beyond it. Trim remaining bolt length to meet required length.
 - Fittings (bolts, nuts, and washers) shall be galvanized in accordance with Item 445, "Galvanizing". Fittings shall be subsidiary to the bid item.
 - Crown shall be widened to accommodate transitions.
 - If solid rock is encountered. See the MGF standard sheet for the proper installation guidance.
 - Posts shall not be set in concrete.
 - Unless otherwise shown in the plans, a composite material post and/or block that meets the requirements of DMS-7210, "Composite Material Posts and Blocks for Metal Beam Guard Fence" may be substituted for posts and/or blocks of similar dimensions. The Construction Division, TxDOT, maintains a Material Producer List (MPL) for producers of materials conforming to DMS-7210. Only producers on the MPL can furnish composite material posts and/or blocks.

NOTES:

(5) 3/8" dia. heavy hex bolts, length will vary depending on width of concrete rail, leave 1" of bolt length past the 3/8" hex nut. Trim as required. See General Notes 6 & 7 for additional connection details.

BRIDGE APPROACH - UPSTREAM: THE NESTED RAIL LAPS OVER THE TERMINAL CONNECTOR. PLATE WASHERS ARE INSTALLED UNDER THE SPLICE NUTS AGAINST INSIDE OF CONNECTOR.

BRIDGE EXIT - DOWNSTREAM: THE TERMINAL CONNECTOR LAPS OVER THE NESTED RAIL. PLATE WASHERS ARE INSTALLED UNDER THE BOLT HEAD AGAINST OUTSIDE OF CONNECTOR.

ONLY FOR USE IN MAINTENANCE REPAIRS.

Design Division Standard

METAL BEAM GUARD FENCE TRANSITION (THRIE-BEAM TRANSITION) MBSF (TR) - 19

FILE: mbgtr19.dgn	DN: TxDOT	CK: KM	DN: BD	CK: VP
© TxDOT NOVEMBER 2019	CONT: SECT	JOB: 644270	HIGHWAY: 001	US 96, ETC.
REVISIONS:	644270	001	US 96, ETC.	
DIST: LFK	COUNTY: SABINE	SHEET NO.:	28	

DISCUSS MFR. THIS STANDARD IS COVERED BY THE TEXAS ENGINEERING PRACTICE ACT. NO WARRANTY OF ANY KIND IS MADE BY TxDOT FOR ANY PURPOSE WHATSOEVER. TxDOT ASSUMES NO RESPONSIBILITY FOR THE CONVERSION OF THIS STANDARD TO OTHER FORMATS OR FOR INCORRECT RESULTS OR DAMAGES RESULTING FROM ITS USE.

DATE: 4/12/2023 FILE: T:\L\FKDM\mnt Contracts\0-RMC - Routine Maintenance Contracts\1923 Plans\6442-70-001 Subline MBGF\JGM\STD\GF3119.dgn

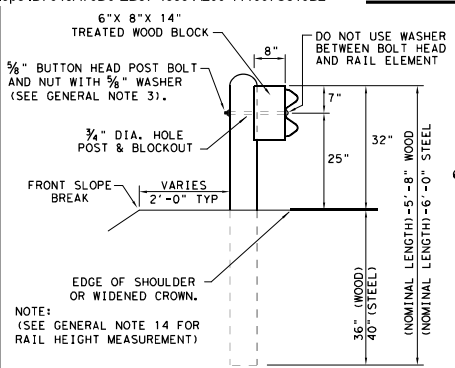

TYPICAL POST PLACEMENT

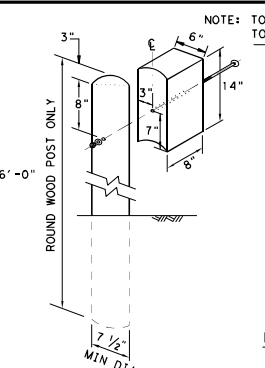

WOOD BLOCK TO ROUND WOOD POST

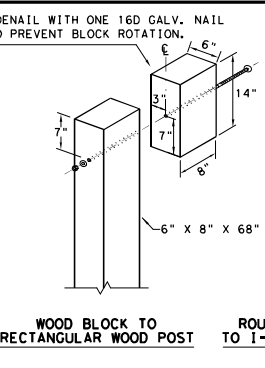

WOOD BLOCK TO RECTANGULAR WOOD POST

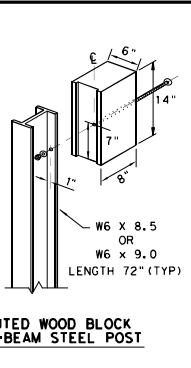

ROUTED WOOD BLOCK TO I-BEAM STEEL POST

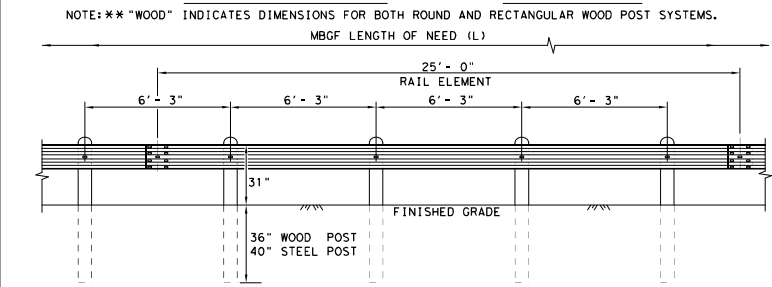

ELEVATION MID-SPAN RAIL SPLICE

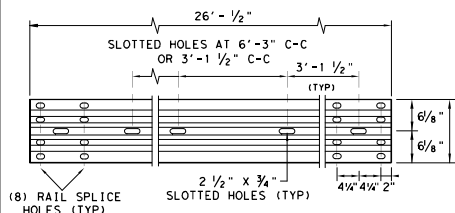

ELEVATION 25' - 0" (NOM.) W-BEAM SECTION

NOTES: SEE GENERAL NOTE 2 FOR ALLOWABLE RAIL TYPES. SEE RAIL SPLICE DETAIL FOR REQUIRED HARDWARE.

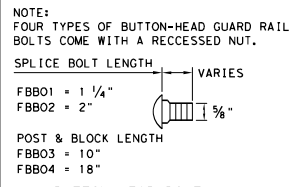

BUTTON HEAD BOLT

NOTE: SEE GENERAL NOTE 3 FOR SPLICE & POST BOLT DETAILS.

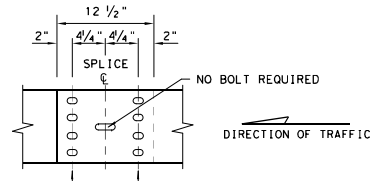

MID-SPAN RAIL SPLICE DETAIL

NOTE: GF(31), MID-SPAN RAIL SPLICES ARE REQUIRED WITH 6'-3" POST SPACINGS.

* POST(S) MAY REQUIRE FIELD MODIFICATION TO ENSURE PROPER GUARDRAIL HEIGHT.

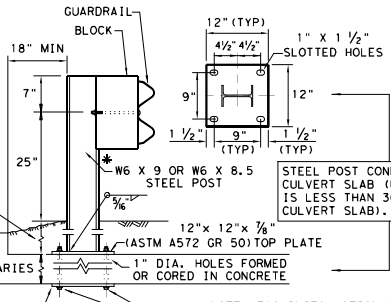

LOW FILL CULVERT POST

- BOLT-THROUGH OPTION:** REQUIRES A 6" MIN. SLAB THICKNESS. 7/8" DIA (ASTM A449) HEAVY HEX BOLTS WITH TWO HARDENED WASHER EACH AND HEAVY HEX NUTS. NOTE: BOLT LENGTH = SLAB PLUS 2 1/4" MIN.
- EPOXY ANCHOR OPTION:** THIS OPTION MAY ONLY BE USED IF THE CULVERT SLAB IS 9" MIN. THICK. THREADED ANCHOR RODS MUST BE 7/8" DIA. ASTM A449 OR A193 GRADE B7 WITH HEAVY HEX NUT, AND ONE HARDENED WASHER EACH. EMBED ANCHOR RODS 6" WITH HILTI HIT RE 500 EPOXY ADHESIVE. OTHER TYPE III CLASS C EPOXY ADHESIVES MEETING THE REQUIREMENTS OF DMS-6100, "EPOXIES AND ADHESIVES", MAY BE USED IF IT CAN BE DEMONSTRATED THAT THEY MEET OR EXCEED THE STRENGTH OF HILTI HIT RE 500 WITH THE SAME EMBEDMENT DEPTH AND THREADED ROD DIA. FOLLOW THE MANUFACTURER'S REQUIREMENTS FOR INSTALLING EPOXIED THREADED RODS. EXTEND RODS 1/4" MIN. BEYOND NUT.

NOTE: CULVERTS OF 25 FT. OR LESS, SEE GF(31)LS STANDARD FOR "LONG SPAN" OPTION.

GENERAL NOTES

- THE TYPE OF POST (ROUND WOOD POST, RECTANGULAR WOOD POST, OR STEEL POST) WILL BE AS SHOWN IN THE PLANS. THE EXACT POSITION OF MBGF SHALL BE SHOWN IN THE PLANS OR AS DIRECTED BY THE ENGINEER. STEEL POSTS TO BE GALVANIZED IN ACCORDANCE WITH ITEM 445, "GALVANIZING."
- RAIL ELEMENTS SHALL MEET THE REQUIREMENTS OF ITEM 540, "METAL BEAM GUARD FENCE" EXCEPT AS MODIFIED IN THE PLANS. THE CONTRACTOR MAY FURNISH RAIL ELEMENTS OF 25'-0", OR 12'-6" (NOM.) LENGTHS. RAIL ELEMENTS MAY HAVE SLOTTED HOLES AT 3'-1 1/2" C-C OR 6'-3" C-C. A SPECIAL LENGTH OF RAIL MAY BE MANUFACTURED TO ACCOMMODATE THE DOWNSTREAM ANCHOR TERMINAL (DAT) AND THE TRANSITION SECTIONS OF GUARDRAIL.
- BUTTON HEAD "POST BOLTS & NUTS" SHALL MEET THE REQUIREMENTS OF (ASTM A307), AND SHALL BE OF SUFFICIENT LENGTH TO EXTEND THROUGH THE FULL THICKNESS OF THE NUT AND 3/4" WASHER (FWC16c) AND NOT MORE THAN 1" BEYOND IT. TRIM REMAINING BOLT LENGTH TO MEET REQUIRED LENGTH.
- FITTINGS (BOLTS, NUTS, AND WASHERS) SHALL BE GALVANIZED IN ACCORDANCE WITH ITEM 445, "GALVANIZING." FITTINGS SHALL BE SUBSIDIARY TO THE BID ITEM.
- CROWN SHALL BE WIDENED TO ACCOMMODATE THE METAL BEAM GUARD FENCE.
- THE LATERAL APPROACH TO THE GUARD FENCE, SHALL HAVE A MAXIMUM SLOPE OF 1V:10H.
- IF SHOWN ELSEWHERE IN THE PLANS OR AS DIRECTED BY THE ENGINEER, THE GUARD FENCE MAY BE FLARED AT A RATE OF 25:1 OR FLATTER.
- UNLESS OTHERWISE SHOWN IN THE PLANS, GUARD FENCE PLACED IN THE VICINITY OF CURBS SHALL BE POSITIONED SO THAT THE FACE OF CURB IS LOCATED DIRECTLY BELOW OR BEHIND THE FACE OF THE RAIL. RAIL PLACED OVER CURBS SHALL BE INSTALLED SO THAT THE POST BOLT IS LOCATED APPROXIMATELY 25 INCHES ABOVE THE GUTTER PAN OR EDGE OF SHOULDER.
- APPLICATIONS IN SOLID ROCK ARE ONLY ALLOWED WITH STEEL POSTS. IF SOLID ROCK IS ENCOUNTERED WITHIN 0 TO 18" OF THE FINISHED GRADE, DRILL A 24" DIA. HOLE, 24" INTO THE ROCK. IF SOLID ROCK IS ENCOUNTERED BELOW 18", DRILL A 12" DIA. HOLE, 12" INTO THE ROCK OR TO THE STANDARD EMBEDMENT DEPTH, WHICHEVER MAYBE LESS. ANY EXCESS POST LENGTH, AFTER MEETING THESE DEPTHS, MAY BE FIELD CUT TO ENSURE PROPER GUARDRAIL MOUNTING HEIGHT. BACKFILL WITH COARSE AGGREGATE MATERIAL.
- POSTS SHALL NOT BE SET IN CONCRETE, OF ANY DEPTH.
- SPECIAL FABRICATION WILL BE REQUIRED AT INSTALLATION LOCATIONS HAVING A CURVATURE OF LESS THAN 150 FT. RADIUS.
- UNLESS OTHERWISE SHOWN IN THE PLANS, A COMPOSITE MATERIAL BLOCK THAT MEETS THE REQUIREMENTS OF DMS-7210, "COMPOSITE MATERIAL POSTS AND BLOCKS FOR METAL BEAM GUARD FENCE" MAY BE SUBSTITUTED FOR BLOCKS OF SIMILAR DIMENSIONS. THE CONSTRUCTION DIVISION, TxDOT MAINTAINS A MATERIAL PRODUCER LIST (MPL) FOR PRODUCERS OF MATERIALS CONFORMING TO DMS-7210 ONLY PRODUCERS ON THE MPL MAY FURNISH COMPOSITE MATERIAL BLOCKS.
- FOR THE LOW FILL CULVERT OPTION, POSTS LOCATED PARTIALLY OR WHOLLY BETWEEN PRECAST BOX CULVERT UNITS, THE USE OF A CAST-IN-PLACE CONCRETE CLOSURE BETWEEN BOXES IS REQUIRED. THE LENGTH OF THE CAST-IN-PLACE CONCRETE CLOSURE SHALL ACCOMMODATE THE PLACEMENT OF THE LOW FILL CULVERT OPTION. SEE CONCRETE CLOSURE DETAILS ON BRIDGE STANDARD SCP-MD.
- GUARDRAIL HEIGHT MEASUREMENT: WHEN THE GUARDRAIL IS LOCATED ABOVE PAVEMENT, MEASURE THE HEIGHT FROM THE PAVEMENT TO THE TOP OF THE W-BEAM RAIL. WHEN THE GUARDRAIL IS LOCATED UP TO 2 FT. OFF OF THE EDGE OF PAVEMENT OR FOR A PAVEMENT OVERLAY, USE A 10-FOOT STRAIGHTEDGE TO EXTEND THE PAVEMENT/SHOULDER SLOPE TO THE BACK OF RAIL, MEASURE FROM THE BOTTOM OF STRAIGHTEDGE TO THE TOP OF RAIL. FOR GUARDRAIL LOCATED DOWN A 10:1 SLOPE, MEASURE FROM THE NOMINAL TERRAIN.

		Design Division Standard	
METAL BEAM GUARD FENCE TL-3 MASH COMPLIANT GF(31)-19			
FILE: gf3119.dgn	DN: TxDOT	CR: KM	DR: VP
REV: NOVEMBER 2019	CONT: 6442	SECT: 70	JOB: 001
REV: NOVEMBER 2019	CONT: 6442	SECT: 70	JOB: 001
DIST: LFK	COUNTY: SABINE	US: 96	ETC.
			SHEET NO. 29

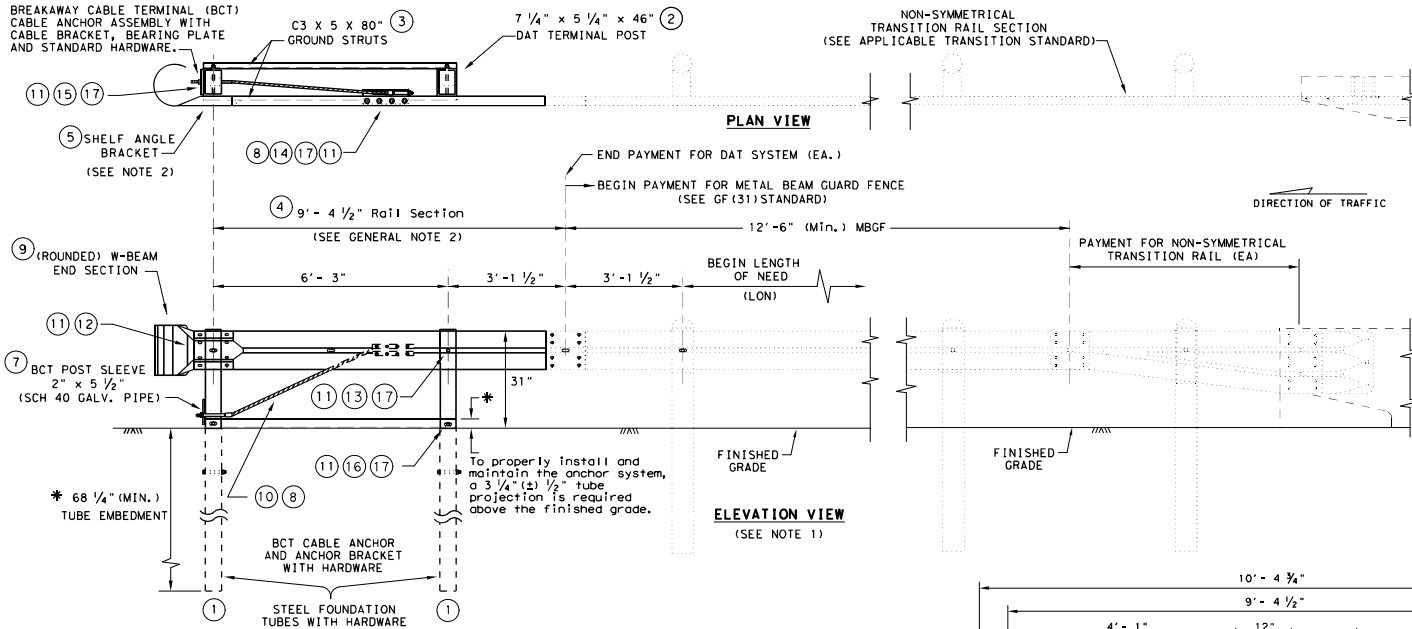

GENERAL NOTES

1. THE DETAIL SHOWN IS THE MINIMUM LENGTH OF NEED (LON) FOR A DOWNSTREAM ANCHOR TERMINAL (DAT) CONNECTED TO A CONCRETE RAIL.
2. THE RAIL SECTION AT THE END POST IS SUPPORTED BY THE SHELF ANGLE BRACKET. THE RAIL ELEMENT IS NOT ATTACHED TO THE END POST.
3. THE FOUNDATION TUBES SHALL NOT PROJECT MORE THAN 3 3/4" ABOVE THE FINISHED GRADE.
4. ALL HARDWARE FOR DAT SHALL BE ASTM A307 UNLESS OTHERWISE SHOWN.
5. REFER TO GF (31) SHEET FOR TERMINAL CONNECTION DETAILS.

MOW STRIP INSTALLATION

IF A MOW STRIP IS REQUIRED WITH THE DAT INSTALLATION THE LEAVE-OUT AREA AROUND THE STEEL FOUNDATION TUBES AND THE TWO CHANNEL STRUTS MAY BE OMITTED. THIS WILL REQUIRE A FULL POUR AT THE FOUNDATION TUBES.

DOWNSTREAM ANCHOR TERMINAL (DAT)

NOTE: ONLY FOR DOWNSTREAM USE, WHEN LOCATED OUTSIDE THE HORIZONTAL CLEARANCE AREA OF OPPOSING TRAFFIC.

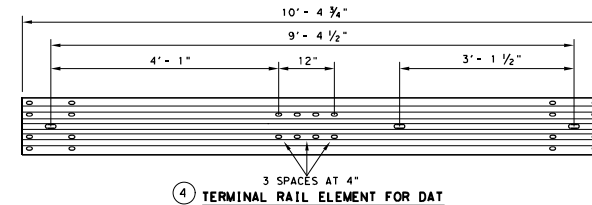

#	(DAT) PARTS LIST	QTY
1	STEEL FOUNDATION TUBE	2
2	DAT TERMINAL POST	2
3	CHANNEL STRUT	2
4	TERMINAL RAIL ELEMENT	1
5	SHELF ANGLE BRACKET	1
6	BCT BEARING PLATE	1
7	BCT POST SLEEVE	1
8	GUARDRAIL ANCHOR BRACKET	1
9	(ROUNDED) W-BEAM END SECTION	1
10	BCT CABLE ANCHOR	1
11	RECESSED NUT, GUARDRAIL	20
12	1 1/4" BUTTON HEAD BOLT	4
13	10" BUTTON HEAD BOLT	2
14	5/8" X 2" HEX HEAD BOLT	8
15	5/8" X 8" HEX HEAD BOLT	4
16	5/8" X 10" HEX HEAD BOLT	2
17	5/8" FLAT WASHER	18

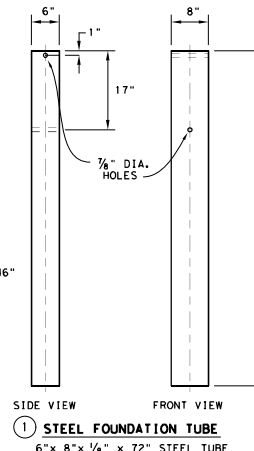
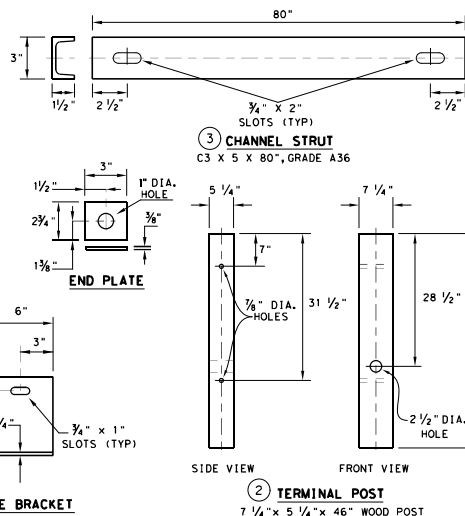
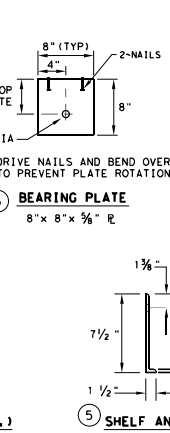
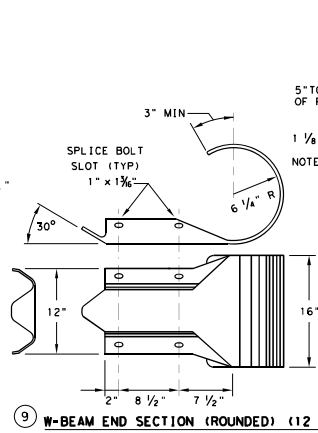
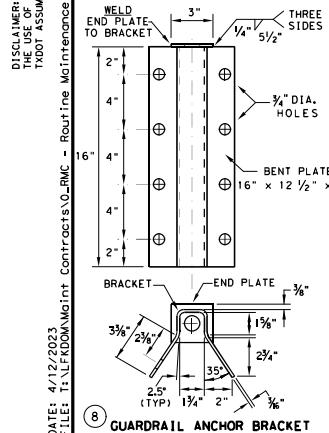

Design Division Standard

METAL BEAM GUARD FENCE (DOWNSTREAM ANCHOR TERMINAL) TL-3 MASH COMPLIANT GF (31) DAT-19

FILE: gf31dat19.dgn	DN: TXDOT	CK: KM	DR: VP	CR: CGL/AG
© TXDOT: NOVEMBER 2019	CONT SECT	JOB	HIGHWAY	
REVISIONS	6442	70	001	US 96, ETC.
	DIST	COUNTY	SHEET NO.	
	LFK	SABINE		30

DISCUSS: THIS STANDARD IS COVERED BY THE "TEXAS ENGINEERING PRACTICE ACT". NO WARRANTY OF ANY KIND IS MADE BY TxDOT FOR ANY PURPOSE WHATSOEVER. TxDOT ASSUMES NO RESPONSIBILITY FOR THE CONVERSION OF THIS STANDARD TO OTHER FORMATS OR FOR INCORRECT RESULTS OR DAMAGES RESULTING FROM ITS USE.
 DATE: 4/12/2023
 FILE: TL-3FDDMgmt Contracts 0-RMC - Routine Maintenance Contracts 1923 Plans 6442-70-001 Sabine MBGF VGM STD gf31dat19.dgn

NOTE: TOENAIL WITH ONE 16D GALV. NAIL TO PREVENT BLOCK ROTATION.

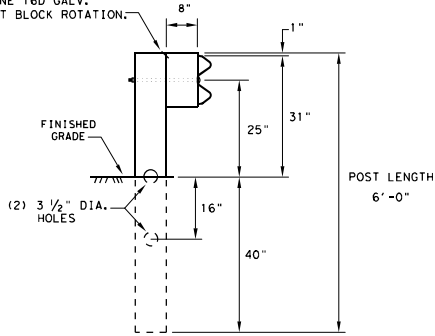

**RECTANGULAR CRT POST
(6' X 8" X 6' LONG)**

(6) CRT REQUIRED
SEE ELEVATION DETAIL FOR LOCATIONS

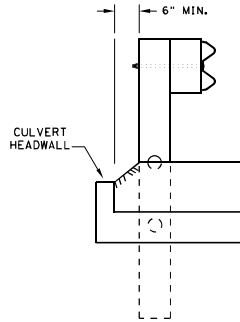

**LATERAL OFFSET BETWEEN THE
GUARDRAIL AND THE CULVERT HEADWALL**

GENERAL NOTES

1. THE TYPE OF LINE POST (ROUND WOOD POST, RECTANGULAR WOOD POST, OR STEEL POST) WILL BE AS SHOWN IN THE PLANS. THE EXACT POSITION OF THE TRANSITIONS SHALL BE AS SHOWN IN THE PLANS OR AS DIRECTED BY THE ENGINEER. STEEL POSTS TO BE GALVANIZED IN ACCORDANCE WITH ITEM 445, "GALVANIZING."
2. RAIL ELEMENT SHALL MEET ALL REQUIREMENTS OF ITEM 540, "METAL BEAM GUARD FENCE" EXCEPT AS MODIFIED ON THE PLANS. THE CONTRACTOR MAY FURNISH RAIL ELEMENTS OF 12'-6" OR 25'-0" NOMINAL LENGTHS.
3. RAIL POST HOLES ARE OFFSET 3'-1 1/2" FROM STANDARD GUARDRAIL TO ACCOMMODATE THE MIDSPAN SPICING.
4. BUTTON HEAD "POST BOLTS & NUTS" SHALL MEET THE REQUIREMENTS OF (ASTM A307), AND SHALL BE OF SUFFICIENT LENGTH TO EXTEND THROUGH THE FULL THICKNESS OF THE NUT AND 5/8" WASHER (FNC16g) AND NO MORE THAN 1" BEYOND IT.
5. FITTINGS (BOLTS, NUTS, AND WASHERS) SHALL BE GALVANIZED IN ACCORDANCE WITH ITEM 445, "GALVANIZING". FITTINGS SHALL BE SUBSIDIARY TO THE BID ITEM.
6. WHERE SOLID ROCK IS ENCOUNTERED, CONTACT THE DESIGN DIVISION FOR ADDITIONAL GUIDANCE. (512) 416-2678
7. POSTS SHALL NOT BE SET IN CONCRETE, OF ANY DEPTH.
8. REFER TO GF(31) STANDARD SHEET FOR ADDITIONAL DETAILS.
9. FLAME CUTTING OF HOLES IN GUARDRAIL SHALL NOT BE PERMITTED. IF YOU ENCOUNTER MIS-ALIGNED BOLT HOLES IN GUARDRAIL CONTACT THE DESIGN DIVISION FOR ADDITIONAL INFORMATION & OPTIONS.

NOTE: SEE GF(31) STANDARD FOR STANDARD LINE POSTS.

DIRECTION OF TRAFFIC

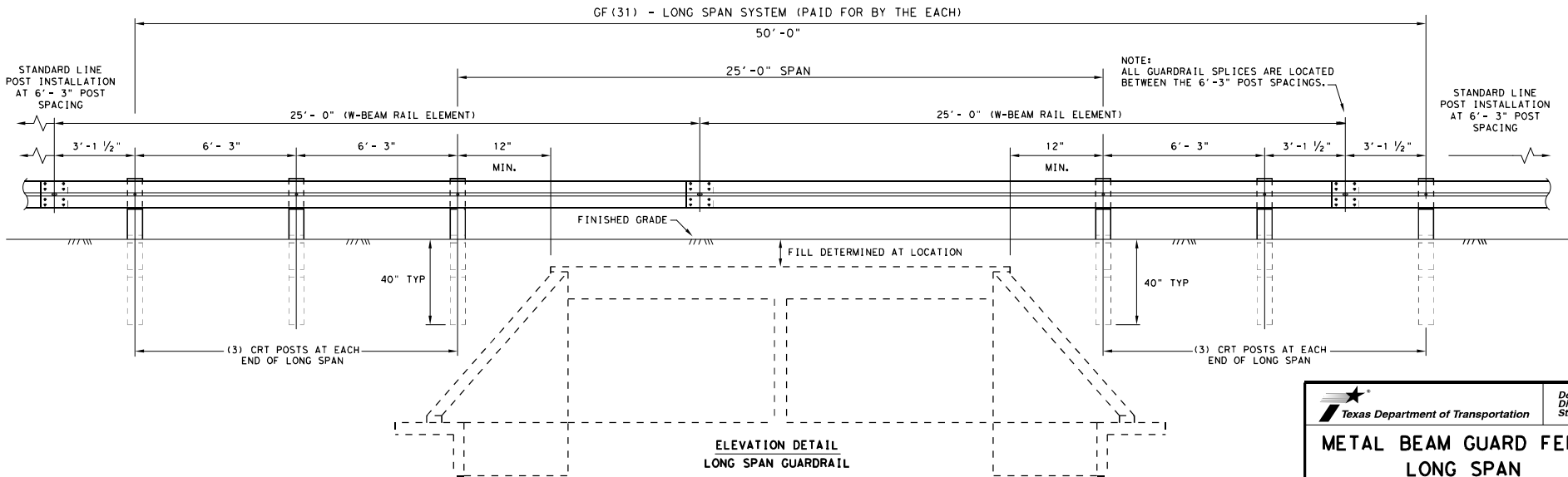

**ELEVATION DETAIL
LONG SPAN GUARDRAIL**

DISCLAIMER: THIS STANDARD IS COVERED BY THE "TEXAS ENGINEERING PRACTICE ACT". NO WARRANTY OF ANY KIND IS MADE BY TxDOT FOR ANY PURPOSE WHATSOEVER. TxDOT ASSUMES NO RESPONSIBILITY FOR THE CONVERSION OF THIS STANDARD TO OTHER FORMATS OR FOR INCORRECT RESULTS OR DAMAGES RESULTING FROM ITS USE.

DATE: 4/12/2023
FILE: T:\LFKDM\mnt Contracts\0-RMC - Routine Maintenance Contracts\1923 Plans\6442-70-001 Sabine MBGF_VGN\STD\GF311s19.dgn

		Design Division Standard	
METAL BEAM GUARD FENCE LONG SPAN TL-3 MASH COMPLIANT GF(31)LS-19			
FILE: gf311s19.dgn	DN: TxDOT	CK: KM	DR: VP
© TxDOT: NOVEMBER 2019	CONT SECT	JOB	HIGHWAY
REVISIONS	6442 70	001	US 96, ETC.
DIST	COUNTY	SHEET NO.	
LFK	SABINE	31	

DISCUSS W/ER. THIS STANDARD IS COVERED BY THE "TEXAS ENGINEERING PRACTICE ACT". NO WARRANTY OF ANY KIND IS MADE BY TxDOT FOR ANY PURPOSE WHATSOEVER. TxDOT ASSUMES NO RESPONSIBILITY FOR THE CONVERSION OF THIS STANDARD TO OTHER FORMATS OR FOR INCORRECT RESULTS OR DAMAGES RESULTING FROM ITS USE.

DATE: 4/12/2023 FILE: T:\L\FKDMaint Contracts\0-RMC - Routine Maintenance Contracts\1723 Plots\16442-70-001 Sabine MBEF\GDM\STD\GF31T10119.dgn

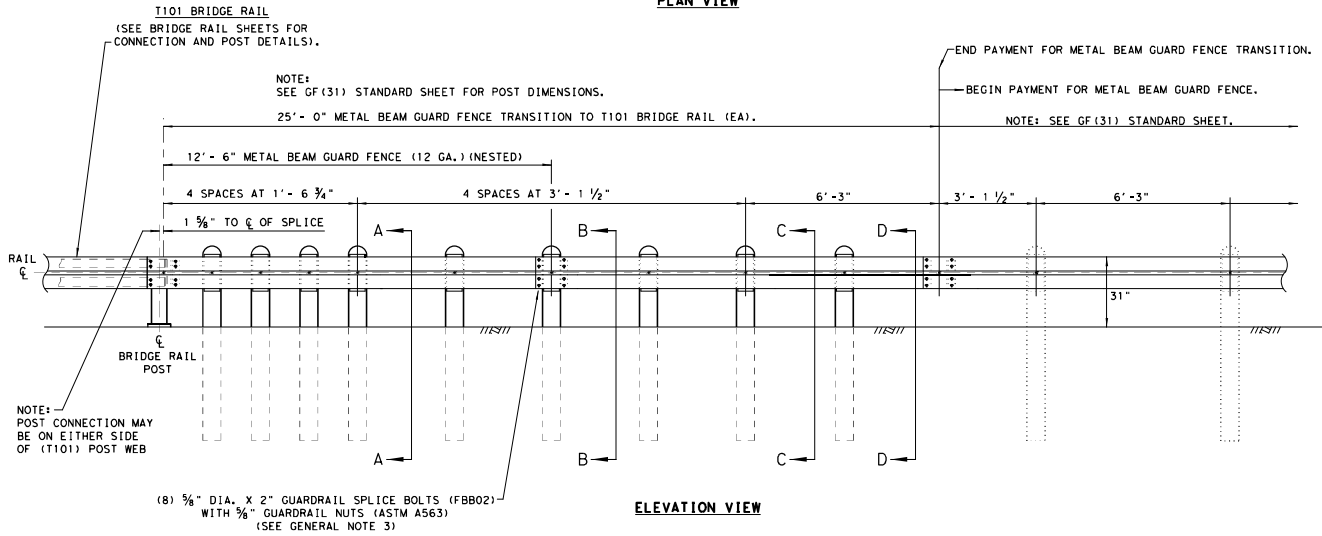
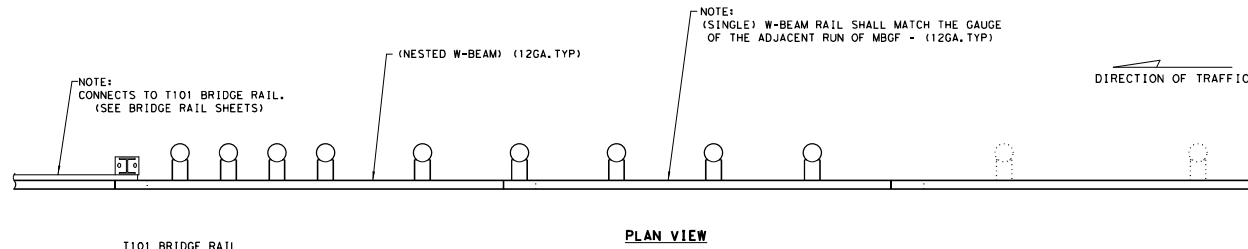

* "WOOD" INDICATES DIMENSIONS FOR BOTH ROUND AND RECTANGULAR WOOD POST SYSTEMS.

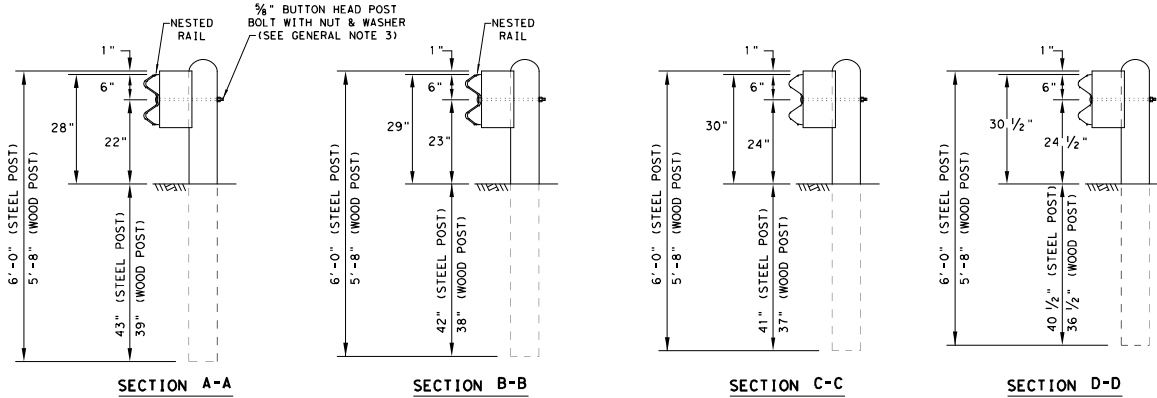

GENERAL NOTES

1. THE TYPE OF POST (ROUND WOOD POST, RECTANGULAR WOOD POST, OR STEEL POST) WILL BE AS SHOWN IN THE PLANS. THE EXACT POSITION OF MBEF SHALL BE SHOWN IN THE PLANS OR AS DIRECTED BY THE ENGINEER. STEEL POSTS TO BE GALVANIZED IN ACCORDANCE WITH ITEM 445, "GALVANIZING."
2. RAIL ELEMENT SHALL MEET THE REQUIREMENTS OF ITEM 540, "METAL BEAM GUARD FENCE" EXCEPT AS MODIFIED IN THE PLANS. THE CONTRACTOR MAY FURNISH RAIL ELEMENTS OF 25'-0", OR 12'-6" (NOM.) LENGTHS. RAIL ELEMENTS MAY HAVE SLOTTED HOLES AT 3'-1 1/2" C-C OR 6'-3" C-C. A SPECIAL LENGTH OF RAIL MAY BE MANUFACTURED TO ACCOMMODATE THE TRANSITION SECTIONS OF GUARDRAIL.
3. BUTTON HEAD "POST" BOLTS (ASTM A307 GR. A) SHALL BE OF SUFFICIENT LENGTH TO EXTEND THROUGH THE FULL THICKNESS OF THE NUT (ASTM A563) AND 5/8" ROUND WASHER (ASTM F436) AND NOT MORE THAN 1" BEYOND IT. BUTTON HEAD "SPLICE" BOLTS (ASTM A307) ARE 5/8" X 1-1/4" WITH 5/8" NUTS (ASTM A563).
4. FITTINGS (BOLTS, NUTS, AND WASHERS) SHALL BE GALVANIZED IN ACCORDANCE WITH ITEM 445, "GALVANIZING." FITTINGS SHALL BE SUBSIDIARY TO THE BID ITEM REQUIRING CONSTRUCTION OF THE TRANSITION.
5. CROWN SHALL BE WIDENED TO ACCOMMODATE THE METAL BEAM GUARD FENCE.
6. WHERE SOLID ROCK IS ENCOUNTERED. CONTACT THE DESIGN DIVISION FOR ADDITIONAL GUIDANCE. (512) 416-2678
7. POSTS SHALL NOT BE SET IN CONCRETE.
8. UNLESS OTHERWISE SHOWN IN THE PLANS, A COMPOSITE MATERIAL BLOCK THAT MEETS THE REQUIREMENTS OF DMS-7210, "COMPOSITE MATERIAL POSTS AND BLOCKS FOR METAL BEAM GUARD FENCE" MAY BE SUBSTITUTED FOR BLOCKS OF SIMILAR DIMENSIONS. THE CONSTRUCTION DIVISION, TxDOT MAINTAINS A MATERIAL PRODUCER LIST (MPL) FOR PRODUCERS OF MATERIALS CONFORMING TO DMS-7210. ONLY PRODUCERS ON THE MPL MAY FURNISH COMPOSITE MATERIAL BLOCKS.
9. REFER TO STANDARD GF(31) AND APPLICABLE BRIDGE RAILING STANDARD FOR ADDITIONAL DETAILS.

		Design Division Standard	
METAL BEAM GUARD FENCE TRANSITION (T101)			
GF (31) T101-19			
FILE: gf31t10119	DN: TxDOT	CK: KM	DR: VP
© TxDOT: NOVEMBER 2019	CONT SECT	JOB	HIGHWAY
REVISIONS	6442 70	001	US 96, ETC.
DIST	COUNTY		SHEET NO.
LFK	SABINE		32

DISCLAIMER: THIS STANDARD IS GOVERNED BY THE "TEXAS ENGINEERING PRACTICE ACT". NO WARRANTY OF ANY KIND IS MADE BY TXDOT FOR ANY PURPOSE WHATSOEVER. TXDOT ASSUMES NO RESPONSIBILITY FOR THE CONVERSION OF THIS STANDARD TO OTHER FORMATS OR FOR INCORRECT RESULTS OR DAMAGES RESULTING FROM ITS USE.

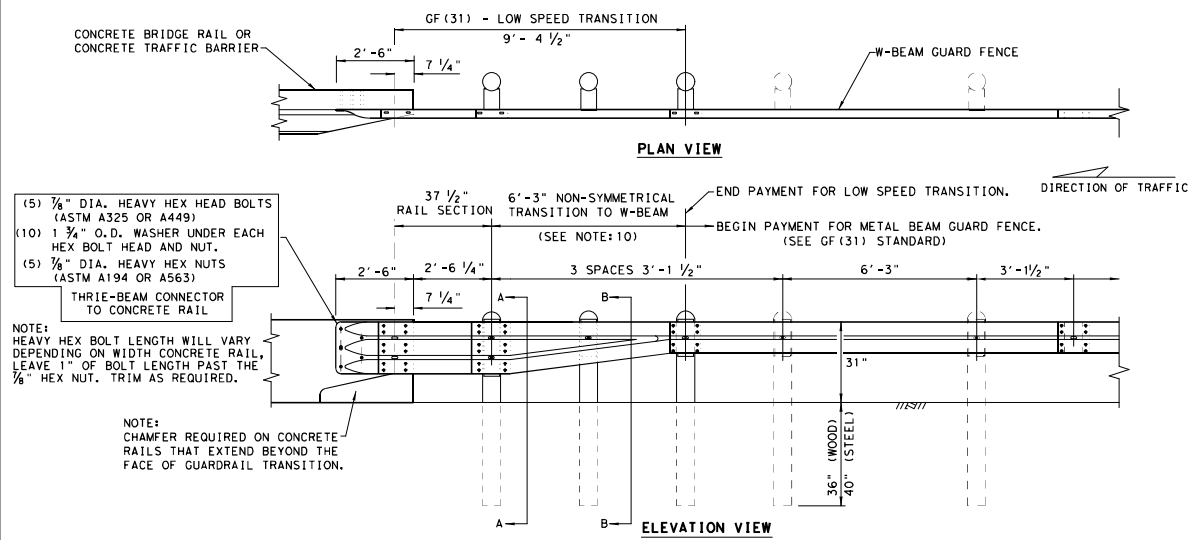

- (5) 7/8" DIA. HEAVY HEX HEAD BOLTS (ASTM A325 OR A449)
 - (10) 1 3/4" O.D. WASHER UNDER EACH HEX BOLT HEAD AND NUT.
 - (5) 7/8" DIA. HEAVY HEX NUTS (ASTM A194 OR A563)
- THRIE-BEAM CONNECTOR TO CONCRETE RAIL
- NOTE: HEAVY HEX BOLT LENGTH WILL VARY DEPENDING ON WIDTH CONCRETE RAIL. LEAVE 1" OF BOLT LENGTH PAST THE 7/8" HEX NUT. TRIM AS REQUIRED.
- NOTE: CHAMFER REQUIRED ON CONCRETE RAILS THAT EXTEND BEYOND THE FACE OF GUARDRAIL TRANSITION.

GENERAL NOTES

1. THE TYPE OF POST (ROUND WOOD POST, RECTANGULAR WOOD POST, OR STEEL POST) WILL BE AS SHOWN IN THE PLANS. THE EXACT POSITION OF TRANSITIONS SHALL BE AS SHOWN IN THE PLANS OR AS DIRECTED BY THE ENGINEER. REFER TO GF(31) STANDARD SHEET.
2. RAIL ELEMENT SHALL MEET THE REQUIREMENTS OF ITEM 540, "METAL BEAM GUARD FENCE" EXCEPT AS MODIFIED IN THE PLANS.
3. FITTINGS (BOLTS, NUTS, AND WASHERS) SHALL BE GALVANIZED IN ACCORDANCE WITH ITEM 445, "GALVANIZING." FITTINGS SHALL BE SUBSIDIARY TO THE BID ITEM REQUIRING CONSTRUCTION OF THE TRANSITION.
4. BUTTON HEAD "POST BOLTS & NUTS" SHALL MEET THE REQUIREMENTS OF (ASTM A307), AND SHALL BE OF SUFFICIENT LENGTH TO EXTEND THROUGH THE FULL THICKNESS OF THE NUT AND 3/8" WASHER (FWC16G) AND NOT MORE THAN 1" BEYOND IT. TRIM BOLT LENGTH TO MEET REQUIRED LENGTH.
5. POSTS SHALL NOT BE SET IN CONCRETE, OF ANY DEPTH.
6. CROWN SHALL BE WIDENED TO ACCOMMODATE TRANSITIONS.
7. WHERE SOLID ROCK IS ENCOUNTERED, CONTACT THE DESIGN DIVISION FOR ADDITIONAL GUIDANCE. (512) 416-2678
8. UNLESS OTHERWISE SHOWN IN THE PLANS, A COMPOSITE MATERIAL BLOCK THAT MEETS THE REQUIREMENTS OF DMS-7210, "COMPOSITE MATERIAL POSTS AND BLOCKS FOR METAL BEAM GUARD FENCE" MAY BE SUBSTITUTED FOR BLOCKS OF SIMILAR DIMENSIONS. THE CONSTRUCTION DIVISION, TXDOT, MAINTAINS A MATERIAL PRODUCER LIST (MPL) FOR PRODUCERS OF MATERIALS CONFORMING TO DMS-7210. ONLY PRODUCERS ON THE MPL CAN FURNISH COMPOSITE MATERIAL BLOCKS.
9. REFER TO GF(31) STANDARD SHEET & BRIDGE RAILING DETAILS FOR ADDITIONAL DETAILS.
10. FOR ROUND WOOD POSTS SYSTEMS, ALL ROUND WOOD POSTS SHALL BE 7 1/2" DIA. MINIMUM THROUGHOUT THE TRANSITION.

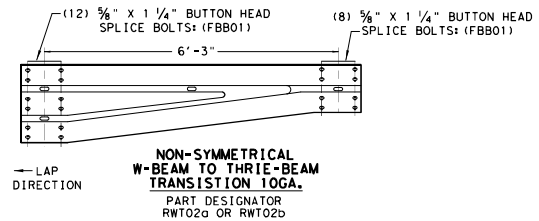
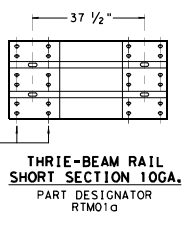
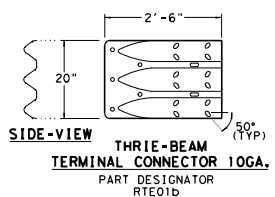

- (2) 5/8" BUTTON HEAD POST BOLTS & NUTS: (FBB04)
- (1) 3/8" FLAT WASHER: (FWC14g) UNDER EACH NUT
- (1) 5/8" BUTTON HEAD POST BOLT & NUT: (FBB04)
- (1) 3/8" FLAT WASHER: (FWC14g) UNDER EACH NUT

PLATE WASHER INSTRUCTIONS

BRIDGE APPROACH - UPSTREAM: THE SHORT RAIL LAPS OVER THE TERMINAL CONNECTOR. PLATE WASHERS ARE INSTALLED UNDER THE SPLICE NUTS AGAINST INSIDE OF CONNECTOR.

BRIDGE EXIT - DOWNSTREAM: THE TERMINAL CONNECTOR LAPS OVER THE NESTED RAIL. PLATE WASHERS ARE INSTALLED UNDER THE BOLT HEAD AGAINST OUTSIDE OF CONNECTOR.

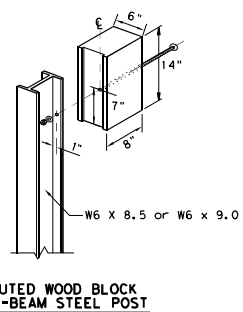
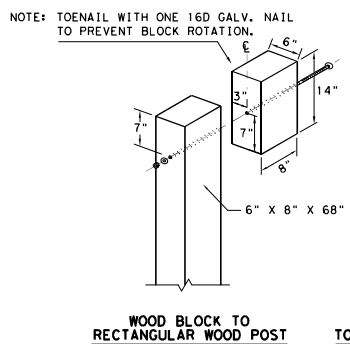
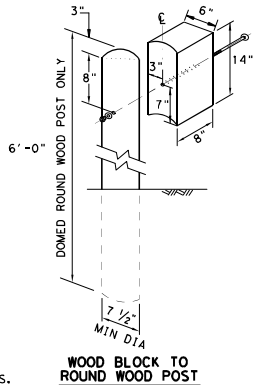
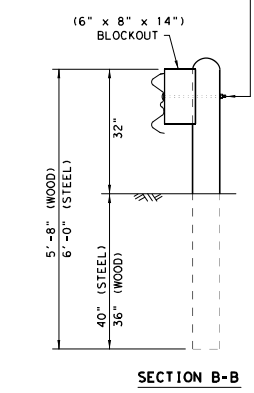
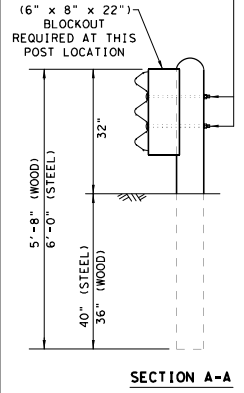

NOTE: * "WOOD" INDICATES DIMENSIONS FOR BOTH ROUND AND RECTANGULAR WOOD POST SYSTEMS.

LOW-SPEED TRANSITION

		Design Division Standard	
METAL BEAM GUARD FENCE THRIE-BEAM TRANSITION TL-2 MASH COMPLIANT GF(31) TR TL2-19			
FILE: gf31trtl219.dgn	DN: TXDOT	CK: KM	DR: VP
© TXDOT: NOVEMBER 2019	CONT SECT	JOB	HIGHWAY
REVISIONS	6442	70	001 US 96, ETC.
DIST	COUNTY		SHEET NO.
LFK	SABINE		33

DISCUSS: THIS STANDARD IS GOVERNED BY THE "TEXAS ENGINEERING PRACTICE ACT". NO WARRANTY OF ANY KIND IS MADE BY TxDOT FOR ANY PURPOSE WHATSOEVER. TxDOT ASSUMES NO RESPONSIBILITY FOR THE CONVERSION OF THIS STANDARD TO OTHER FORMATS OR FOR INCORRECT RESULTS OR DAMAGES RESULTING FROM ITS USE.
 DATE: 4/12/2023
 FILE: T:\LFK\DM\mnt Contracts\0.RMC - Routine Maintenance Contracts\123 Plans\6442-70-001 Sabine MGF_VGN\STD\GF31tr+1320.dgn

REQUIRED ALTERNATIVE FOR CONTINUOUS CURB EXTENDING PAST POST 7 (SEE SHT. 1 GENERAL NOTE 17)

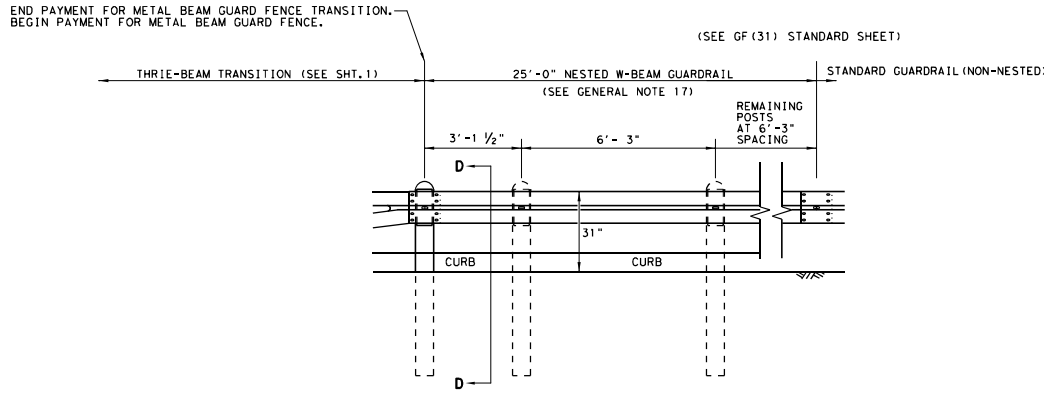

ELEVATION VIEW

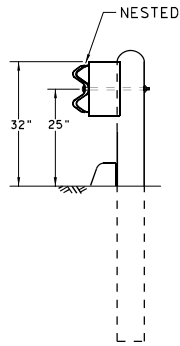

SECTION D-D

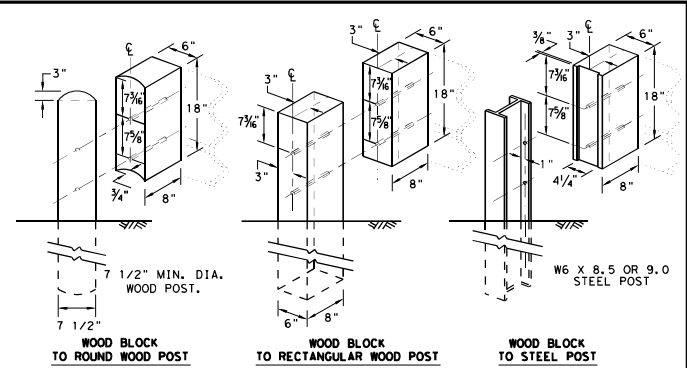

THREE BEAM TRANSITION BLOCKOUT DETAILS

HIGH-SPEED TRANSITION

SHEET 2 OF 2

		Design Division Standard	
METAL BEAM GUARD FENCE THREE-BEAM TRANSITION TL-3 MASH COMPLIANT GF (31) TR TL3-20			
FILE: gf31tr+1320.dgn	DN: TxDOT	CK: KM	DR: KM
© TxDOT: NOVEMBER 2020	CONT	SECT	JOB
REVISIONS	6442	70	001 US 96, ETC.
DIST	COUNTY		SHEET NO.
LFK	SABINE		35

DISCLAIMER: The use of this standard is governed by the "Texas Engineering Practice Act". No warranty of any kind is made by TxDOT for any purpose whatsoever. TxDOT assumes no responsibility for the conversion of this standard to other formats or for incorrect results or damages resulting from its use.

DATE: 4/12/2023
 FILE: T:\LFK\DM\Main\Contract\00.RMC - Routine Maintenance\Contract\023\Plans\6442-70-001 Sabine MBGF\00M\STD\cccc22.dgn

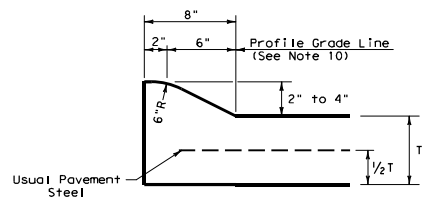

TYPE I CURB (MONOLITHIC)
2" - 4" HEIGHT

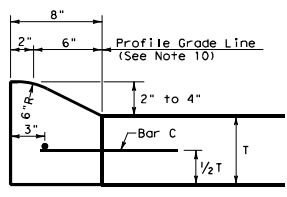

TYPE I CURB
2" - 4" HEIGHT

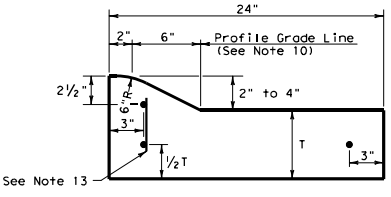

TYPE I CURB AND GUTTER
2" - 4" HEIGHT

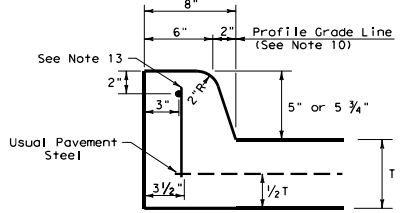

TYPE II CURB (MONOLITHIC)
5" - 5 3/4" HEIGHT

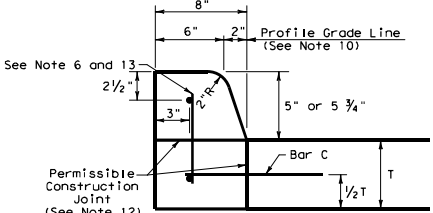

TYPE II CURB
5" - 5 3/4" HEIGHT

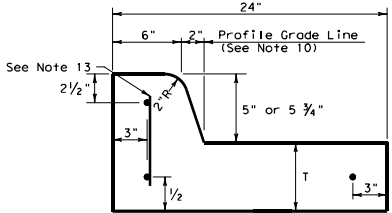

TYPE II CURB AND GUTTER
5" - 5 3/4" HEIGHT

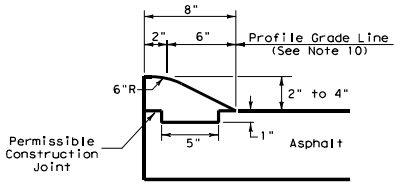

TYPE III CURB (KEYED)
2" - 4" HEIGHT

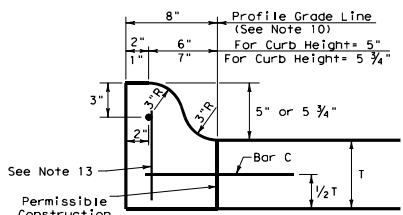

TYPE IIa CURB
5" - 5 3/4" HEIGHT

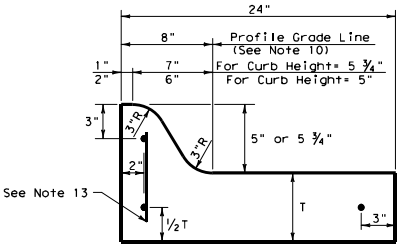

TYPE IIa CURB AND GUTTER
5" - 5 3/4" HEIGHT

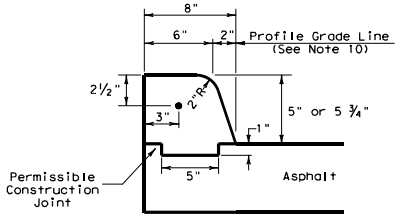

TYPE IV CURB (KEYED)
5" - 5 3/4" HEIGHT

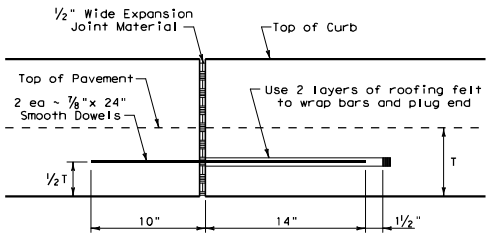

EXPANSION JOINT DETAIL

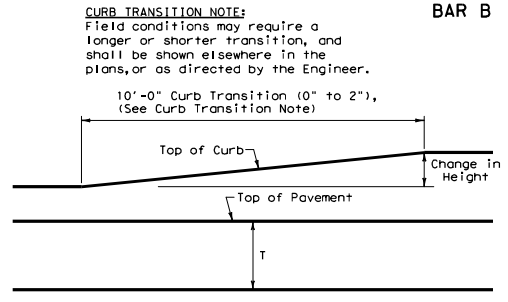

CURB TRANSITION
Note: To be paid for as Highest Curb

GENERAL NOTES

- All materials and construction shall be in accordance with Item 529, "Concrete Curb, Gutter, and Combined Curb and Gutter."
- Concrete shall be Class A.
- When reinforcing bars are used, they shall be No.4 unless otherwise shown. The use of fiber reinforced concrete in lieu of reinforcing steel is acceptable. Use fibers meeting the requirements of DMS 4550, "Fibers for Concrete," and dose fibers in accordance with Material Producers List (MPL) "Fibers for Class A and B Concrete Applications."
- Round exposed sharp edges with a rounding tool, to a minimum radius of 1/4 inch.
- All existing curbs and driveways to be removed shall be sawed or removed at existing joints.
- Where concrete curb is to be placed on existing concrete pavement, Bar B may be drilled and grouted in place, or may be inserted into fresh concrete.
- Expansion and contraction joints shall be constructed to match pavement joints in all curbs and curb and gutter adjacent to jointed concrete pavement. Where placement of curb or curb and gutter is not adjacent to concrete pavement, expansion joints shall be provided at structures, curb returns at streets, and at locations directed by The Engineer.
- Vertical and horizontal dowel bars and transverse reinforcing bars shall be placed at four feet C-C.
- Dimension 'T' shown is the thickness of concrete pavement. When curb is installed adjacent to flexible pavement dimension 'T' is 8" maximum.
- Usual profile grade line. Refer to typical sections and plan-profile sheets for exact locations.
- One-half inch expansion joint material shall be provided where curb or curb and gutter is adjacent to sidewalk or r/prop.
- When horizontal permissible construction joints are used, the longitudinal pavement steel shall be placed in accordance with pavement details shown elsewhere in the plans. Reinforcing steel for curb section shall then conform to that required for concrete curb.
- Bar B placement as needed (typically at four ft. C-C) to support curb reinforcing steel during concrete placement.

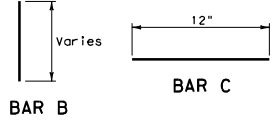

CURB TRANSITION NOTE:
Field conditions may require a longer or shorter transition, and shall be shown elsewhere in the plans, or as directed by The Engineer.

				Design Division Standard	
CONCRETE CURB AND GUTTER					
CCCC-22					
FILE: cccg21.dgn	DN: TXDOT	CR: AN	DM: CS	DR: KM	
© TXDOT: JUNE 2022	CONT: 6442	SECT: 70	JOB: 001	US 96, ETC.	
	DIST: LFK	COUNTY: SABINE	SHEET NO.:		36

DATE: 4/12/2023
 FILE: I:\LFKDM\mnt Contracts\0-RMC - Routine Maintenance Contracts\123 Plans\6442-70-001 Sabine MGR\00M\STD\Traccw16.dgn
 DISCLAIMER: This standard is covered by the "Texas Engineering Practice Act". No warranty of any kind is made by TxDOT for any purpose whatsoever. TxDOT assumes no responsibility for the conversion of this standard to other formats or for inaccuracies or damages resulting from its use.

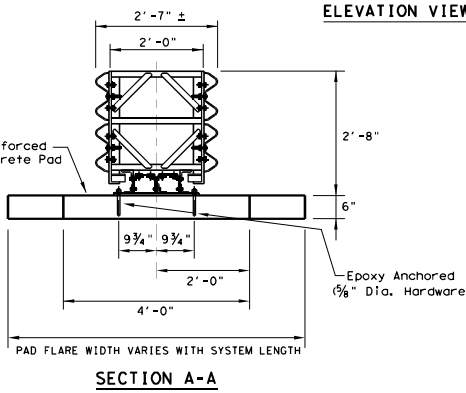
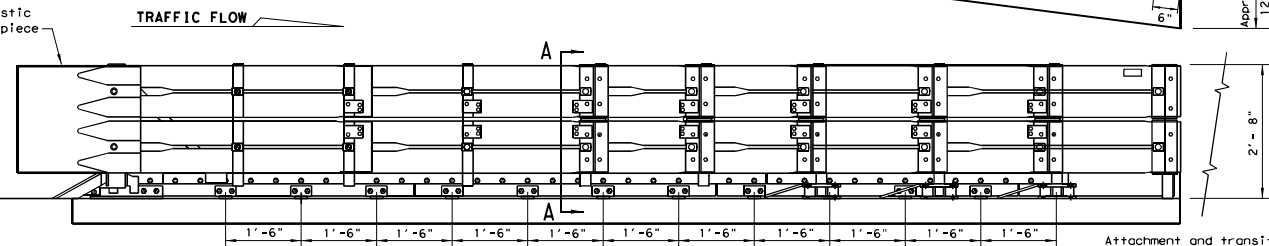
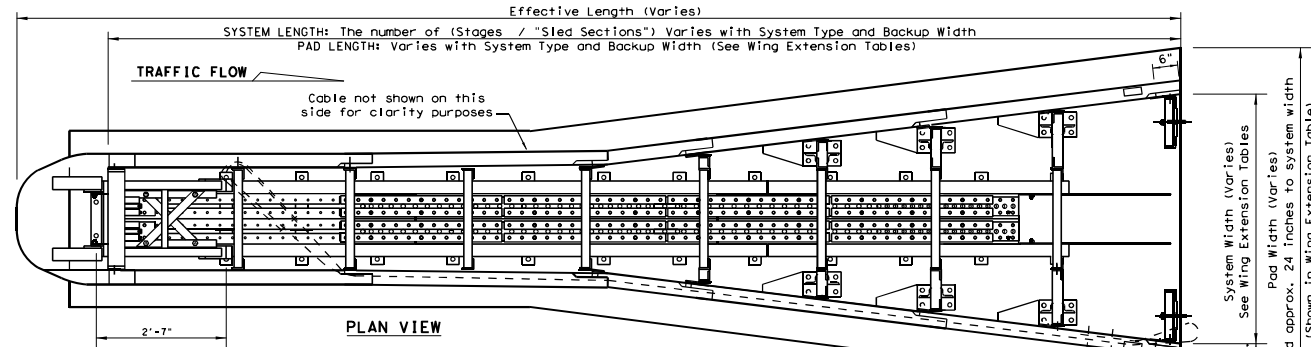

TYPE (WIDE)	TEST LEVEL
FASTRACC (4 Stage System)	70
TRACC (3 Stage System)	TL-3
SHORTTRACC (2 Stage System)	TL-2

NOTE: The Stage System refers to number of replaceable "sled sections" that could be replaced independently.

Wide-FASTRACC WING EXTENSIONS				
NUMBER OF WING EXTENSIONS	WIDTH	SYSTEM LENGTH	EFFECTIVE LENGTH	Wide-FASTRACC EXTENSION PART NUMBER (LEFT# / RIGHT#)
0 (BASE UNIT)	71"	25'-11"	27'-11"	33940
1	85"	28'-7"	30'-7"	33941 / 33942
2	92"	32'-11"	34'-11"	33943 / 33944
3	99"	35'-2"	37'-2"	33945 / 33946
4	106"	37'-6"	39'-6"	33947 / 33948
5	113"	39'-10"	41'-10"	33949 / 33950
6	120"	42'-2"	44'-2"	33951 / 33952
7	127"	44'-5"	46'-5"	33953 / 33954
8	134"	46'-9"	48'-9"	33955 / 33956
9	141"	49'-1"	51'-1"	33957 / 33958
10+				CONSULT TRINITY SALES PERSON

Wide-TRACC WING EXTENSIONS				
NUMBER OF WING EXTENSIONS	WIDTH	SYSTEM LENGTH	EFFECTIVE LENGTH	Wide-TRACC EXTENSION PART NUMBER (LEFT# / RIGHT#)
0 (BASE UNIT)	58"	21'	23'	33940
1	65"	23'-4"	25'-4"	33941 / 33942
2	72"	25'-8"	27'-8"	33943 / 33944
3	79"	28'	30'	33945 / 33946
4	86"	30'-4"	32'-4"	33947 / 33948
5	92"	32'-8"	34'-8"	33949 / 33948
6	99"	35'	37'	33949 / 33950
7	106"	37'-4"	39'-4"	33951 / 33952
8	113"	39'-8"	41'-8"	33953 / 33954
9	120"	42'	44'	33955 / 33956
10	127"	44'-4"	46'-4"	33957 / 33958
10+				CONSULT TRINITY SALES PERSON

Wide-SHORTTRACC WING EXTENSIONS				
NUMBER OF WING EXTENSIONS	WIDTH	SYSTEM LENGTH	EFFECTIVE LENGTH	Wide-SHORTTRACC EXTENSION PART NUMBER (LEFT# / RIGHT#)
0 (BASE UNIT)	39"	15'	17'	33940
1	46"	17'-4"	19'-4"	33941 / 33942
2	53"	18'-9"	20'-9"	33943 / 33944
3	60"	21'-1"	23'-1"	33945 / 33946
4	66"	23'-5"	25'-5"	33947 / 33948
5	73"	25'-8"	27'-8"	33949 / 33950
6	80"	28'-1"	30'-1"	33949 / 33950
7	87"	30'-4"	32'-4"	33951 / 33952
8	94"	32'-7"	34'-7"	33953 / 33954
9	101"	34'-11"	36'-11"	33955 / 33956
10	108"	37'-3"	39'-3"	33957 / 33958
10+				CONSULT TRINITY SALES PERSON

- GENERAL NOTES**
- For specific information regarding installation and technical guidance of the system, contact: Trinity Highway at (888)323-6374, 2525 N. Stemmons Freeway - Dallas, TX 75207
 - Contact the company for: Custom widths from 31" up to 57" wide, and transition panels for bi-directional traffic applications.
 - Details of components for the WideTRACC, Backups and re-inforcing details will be shown on the manufacturer's shop drawings furnished to the Engineer.
 - Concrete shall be class "5" with a min. compressive strength 4,000 p.s.i.
 - If the cross-slope varies more than 2% over the length of the system, the concrete pad will require leveling. Maximum permissible cross-slope 8%.
 - The installation area should be free from curbs, elevated objects, or depressions.
 - The WideTRACC system should be approximately parallel with the barrier or $\frac{1}{2}$ of merging barriers.
 - The unit shown is flared on both sides, but can be flared on a single side either left or right. The flares will effect the length and width of the system. (See Wing Extension Tables)

Wide-TRACC - BILL OF MATERIAL				
PART #	FAST TRACC QTY	TRACC QTY	SHORT TRACC QTY	DESCRIPTION
25937A	1			WIDEFASTRACC UNIT ASSEMBLY
25939A		1		WIDE TRACC UNIT ASSEMBLY
25997A			1	WIDESHORTTRACC UNIT ASSEMBLY
3310G	4	4	4	5/8" LOCKWASHER
4372C	4	4	4	5/8" FLATWASHER
4451G	4	4	4	5/8" DIA X 6" EXP. WEDGE ANCHOR
6531B	1	1	1	PLASTIC NOSEPIECE
6668B	4	4	4	REFLECTIVE SHEETING
ANCHOR HARDWARE (CONCRETE BASE)				
5204B	72	50	18	5/8" DIA X 7-1/2" THD ANCHOR STUD
4372G	72	50	18	5/8" FLATWASHER
3310G	72	50	18	5/8" LOCKWASHER
3361G	72	50	18	5/8" HEX NUT
5206B	6	4	2	Adhesive, HILTI HIT HY-150
ANCHOR HARDWARE (ASPHALT BASE)				
6380G	72	50	18	5/8" Dia x 18" Thd Anchor Stud
4372C	72	50	18	5/8" Flatwasher
3310G	72	50	18	5/8" Lockwasher
3361G	72	50	18	5/8" HEX NUT
5206B	15	11	4	ADHESIVE, HILTI HIT HY-150
ANCHOR HARDWARE (OPTIONAL ITEMS, AS NEEDED)				
5207B	A/R	A/R	A/R	NOZZLE, MIXER, HILTI HIT HY-150
5208B	A/R	A/R	A/R	EXT. TUBE, MIXER, HILTI HIT HY-150
5205B	A/R	A/R	A/R	DISPENSER GUN, HILTI HIT HY-150
5209B	A/R	A/R	A/R	DRILL BIT, 1/2", HILTI SDS

Attachment and transitions to other shapes, barriers, railings and bi-directional traffic flows are available. (See manufacturer's product manual).

- BACKUP SUPPORT OPTIONS**
- SQUARE CONCRETE BACKUP
 - CONCRETE BARRIER (CTB) BACKUP
 - SINGLE SLOPE CONCRETE BARRIER (SSCB)
 - GUARDRAIL BACKUP (BASE-PLATED POST)
 - GUARDRAIL BACKUP (DRIVEN POST)
- TRANSITION OPTIONS**
- VERTICAL WALL
 - MODIFIED (CTB) TO VERTICAL WALL
 - CONCRETE BARRIER (CTB)
 - GUARDRAIL (W-BEAM)
 - GUARDRAIL (THREE-BEAM)
- FOR BI-DIRECTIONAL TRANSITION PANEL DETAILS (SEE MANUFACTURER'S PRODUCT MANUAL).
- BACKUP AND TRANSITION TYPES ARE SHOWN ELSEWHERE ON THE PLANS, (I.E., ATTENUATOR LOCATION DETAILS) OR IN THE GENERAL NOTES).

- FOUNDATION OPTIONS**
- 6" REINFORCED CONCRETE
 - 8" UNREINFORCED CONCRETE
 - 3" MIN. ASPHALT OVER 3" MIN. CONCRETE
 - 6" ASPHALT OVER 6" COMPACT SUBBASE
 - 8" MINIMUM ASPHALT
- FOR STEEL PLACEMENT IN CONCRETE FOUNDATIONS, (SEE MANUFACTURER'S PRODUCT MANUAL).

REUSABLE

Texas Department of Transportation
 Design Division Standard

**TRINITY HIGHWAY
 CRASH CUSHION
 (WIDE UNIT)
 TRACC (W) - 16**

FILE: traccw16.dgn	DN: TxDOT	CK: KM	DN: VP	CK: VP
© TxDOT February 2006	CONT	SECT	JOB	HIGHWAY
REVISIONS	6442	70	001	US 96, ETC.
REVISED 06, 2015 (VP)	DIST	COUNTY	SHEET NO.	
REVISED 03, 2016 (VP)	LFK	SABINE		37

DISCLAIMER: The use of this standard is governed by the "Texas Engineering Practice Act". No warranty of any kind is made by TxDOT for any purpose whatsoever. TxDOT assumes no responsibility for the conversion of this standard into a contract or for any errors or omissions. The user of this standard assumes all liability for damages resulting from its use.

REFLECTOR UNIT SIZES FOR DELINEATORS AND OBJECT MARKERS

DELINEATORS

D & OM DESCRIPTIVE CODES

DEVICE	SIZE 1	SIZE 2	SIZE 3	SIZE 4
SHEETING	Yellow, White or Red Type B or C reflective sheeting			

DEVICE	SINGLE	DOUBLE
SHEETING	Yellow, White or Red Type B or C Reflective Sheeting	

INSTL DEL ASSM (D-XX) SZ X (XXXX) XXX (XX)
 NUMBER OF REFLECTORS
 S = Single
 D = Double
 COLOR OF REFLECTORS
 W = White
 Y = Yellow
 R = Red
 REFLECTOR UNIT SIZE
 1 or 2
 TYPE OF POST OR DELINEATOR
 WC = Wing Channel Post
 YFLX = Yellow Flexible Post
 WFLX = White Flexible Post
 BR = Barrier Reflector
 TYPE OF MOUNT
 GND = Embedded (drivable or set in concrete)
 CTB = Concrete Barrier Mount
 GF1 or GF2 = Guard Fence Attachment
 SRF = Surface Mount

NOTE
 1. Size 1 and 4 - Direct applied reflective sheeting for use on flexible post (flx).
 2. Size 2 and 3 - For use on wing channel (wc) post only. Use approved metal, plastic or fiberglass backplate with 17/64" mounting holes.

SHEETING	POST TYPE	MOUNT TYPE
Yellow, White or Red Type B or C Reflective Sheeting	WC, YFLX, WFLX	GND, GND, SRF

INSTL OM ASSM (OM-XX) (XXXX) XXX (XX)
 TYPE OF OBJECT MARKER
 1, 2, 3, or 4
 NUMBER OF REFLECTORS OR DIRECTION
 X = 3-Size 2 reflector units (Type 2 only)
 Y = 1-Size 3 reflector unit (Type 2 only)
 Z = 3-Size 1 or 1-Size 4 reflector unit (Type 2 only)
 L = Left Side (Type 3 Object Marker only)
 R = Right Side (Type 3 Object Marker only)
 C = Center (Type 3 Object Marker only)

OBJECT MARKERS

DEVICE	Type 1 (OM-1)	Type 2 (OM-2)	Type 3 (OM-3)	Type 4 (OM-4)
SHEETING	Yellow-Type B _{FL} or C _{FL} Sheeting	Yellow - Type B or C Sheeting		Red -Type B _{FL} or C _{FL} Sheeting
POST TYPE	TWT	WC	WFLX	TWT
MOUNT TYPE	WAS, WAP	GND	GND, SRF	WAS, WAP

DEVICE	OM-3L	OM-3R	OM-3C
SHEETING	Alternating acrylic black and retroreflective yellow - Type B _{FL} or C _{FL} Sheeting		
POST TYPE	TWT		
MOUNT TYPE	WAS, WAP		

TYPE OF MOUNT
 GND = Embedded (drivable)
 SRF = Surface Mount
 WAS = Wedge Anchor Steel
 WAP = Wedge Anchor Plastic
 DIRECTION
 If Required
 BI = Bi-Directional

DEPARTMENTAL MATERIAL SPECIFICATIONS	
FLEXIBLE DELINEATOR & OBJECT MARKER POSTS (EMBEDDED & SURFACE MOUNT TYPES)	DMS-4400
SIGN FACE MATERIALS	DMS-8300
DELINEATORS, OBJECT MARKERS AND BARRIER REFLECTORS	DMS-8600

BARRIER REFLECTORS (BRF)

CHEVRONS

ONE DIRECTION LARGE ARROW

NOTE:
 Delineator and object marker substrates and sign substrates shall be 0.080" Aluminum sign blank to conform to ASTM B-209 Alloy 6061-T6 or approved alternative.

DEVICE	GF1	GF2	CTB
SHEETING	Yellow, White, Red		

DEVICE	W1-8
SIZE (W x L)	18"x 24" (Conventional), 24"x 30" (Conventional Oversize), 30"x 36" (Expressway), 36" x 48" (Freeway)
MOUNTING HEIGHT	4'-0" or 7'-0" (Conventional), 7'-0" Only (Expressway & Freeway)

DEVICE	W1-6
SIZE (W x L)	48" x 24" (Conventional), 60" x 30" (Expressway & Freeway)
MOUNTING HEIGHT	7'-0"

NOTE
 1. Barrier reflectors shall meet the requirements of DMS 8600.
 2. Approved Barrier Reflectors are listed on the "Barrier Reflectors" Material Producer List at: www.txdot.gov.

NOTE
 1. CHEVRON (W1-8) signs and ONE DIRECTION LARGE ARROW (W1-6) Signs shall be installed per Sign Mounting Details (SMD) Standard Sheets and paid under Item 644 (Small Roadside Sign Assemblies).
 2. When there is a need to increase conspicuity, the Texas version of the ONE DIRECTION LARGE ARROW sign (W1-9T) may be used instead of the ONE DIRECTION LARGE ARROW (W1-6).

Texas Department of Transportation
 Traffic Safety Division Standard

DELINEATOR & OBJECT MARKER MATERIAL DESCRIPTION
D & OM(1)-20

FILE: dcm1-20.dgn	DN: TXDOT	CK: TXDOT	DN: TXDOT	CK: TXDOT
© TXDOT August 2004	CONT	SECT	JOB	HIGHWAY
REVISIONS	6442	70	001	US 96, ETC.
10-09 3-15	DIST	COUNTY	SHEET NO.	
4-10 7-20	LFK	SABINE	38	

DISCLAIMER: The use of this standard is governed by the "Texas Engineering Practice Act". No warranty of any kind is made by TxDOT for any purpose whatsoever. TxDOT assumes no responsibility for the conversion of units or the accuracy of the information contained herein.

DATE: 4/12/2023 7:38:02 AM
 FILE: T:\LKFD\Main\Int Contracts\0-RMC - Routine Maintenance Contracts\1523 of Lights\delimiters\031523.dwg

MINIMUM WARNING DEVICES AT CURVES WITH ADVISORY SPEEDS

Amount by which Advisory Speed is less than Posted Speed	Curve Advisory Speed	
	Turn (30 MPH or less)	Curve (35 MPH or more)
5 MPH & 10 MPH	• RPMs	• RPMs
15 MPH & 20 MPH	• RPMs and One Direction Large Arrow sign	• RPMs and Chevrons; or • RPMs and One Direction Large Arrow sign where geometric conditions or roadside obstacles prevent the installation of chevrons.
25 MPH & more	• RPMs and Chevrons; or • RPMs and One Direction Large Arrow sign where geometric conditions or roadside obstacles prevent the installation of chevrons	• RPMs and Chevrons

SUGGESTED SPACING FOR DELINEATORS ON HORIZONTAL CURVES

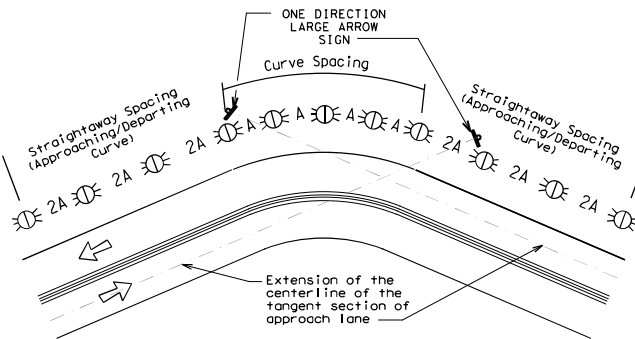

NOTE
 ONE DIRECTION LARGE ARROW (W1-6) sign should be located at approximately and perpendicular to the extension of the centerline of the tangent section of approach lane.

SUGGESTED SPACING FOR CHEVRONS ON HORIZONTAL CURVES

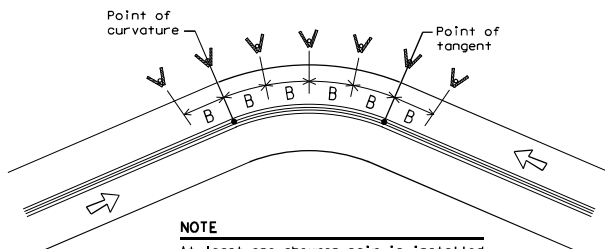

NOTE
 At least one chevron pair is installed beyond the point of tangent in tangent section.

DELINEATOR AND CHEVRON SPACING

WHEN DEGREE OF CURVE OR RADIUS IS KNOWN				
Degree of Curve	FEET			
	Radius of Curve	Spacing in Curve	Spacing in Straightway	
			A	B
1	5730	225	450	—
2	2865	160	320	—
3	1910	130	260	200
4	1433	110	220	160
5	1146	100	200	160
6	955	90	180	160
7	819	85	170	160
8	716	75	150	160
9	637	75	150	120
10	573	70	140	120
11	521	65	130	120
12	478	60	120	120
13	441	60	120	120
14	409	55	110	80
15	382	55	110	80
16	358	55	110	80
19	302	50	100	80
23	249	40	80	80
29	198	35	70	40
38	151	30	60	40
57	101	20	40	40

Curve delineator approach and departure spacing should include 3 delineators spaced at 2A. This spacing should be used during design preparation or when the degree of curve is known.

DELINEATOR AND CHEVRON SPACING

WHEN DEGREE OF CURVE OR RADIUS IS NOT KNOWN			
Advisory Speed (MPH)	Spacing in Curve	Spacing in Straightway	
		A	B
65	130	260	200
60	110	220	160
55	100	200	160
50	85	170	160
45	75	150	120
40	70	140	120
35	60	120	120
30	55	110	80
25	50	100	80
20	40	80	80
15	35	70	40

If the degree of curve is not known, delineator spacing may be determined based on the Advisory Speed of the curve. Use the delineator curve spacing for each Advisory Speed (MPH).

DELINEATOR AND OBJECT MARKER APPLICATION AND SPACING

CONDITION	REQUIRED TREATMENT	MINIMUM SPACING
Frwy./Exp. Tangent	RPMs	See PM-series and FPM-series standard sheets
Frwy./Exp. Curve	Single delineators on right side	See delineator spacing table
Frwy./Exp. Ramp	Single delineators on at least one side of ramp (should be on outside of curves) (see Detail 3 on D&OM(4))	100 feet on ramp tangents Use delineator spacing table for ramp curves ("straightway spacing" does not apply to ramp curves)
Acceleration/Deceleration Lane	Double delineators (see Detail 3 on D&OM(4))	100 feet (See Detail 3 on D & OM (4))
Truck Escape Ramp	Single red delineators on both sides	50 feet
Bridge Rail (steel or concrete) and Metal Beam Guard Fence	Bi-Directional Delineators when undivided with one lane each direction Single Delineators when multiple lanes each direction	Equal spacing (100' max) but not less than 3 delineators
Concrete Traffic Barrier (CTB) or Steel Traffic Barrier	Barrier reflectors matching the color of the edge line	Equal spacing 100' max
Cable Barrier	Reflectors matching the color of the edge line	Every 5th cable barrier post (up to 100' max)
Guard Rail Terminus/Impact Head	Divided highway - Object marker on approach end Undivided 2-lane highways - Object marker on approach and departure end	Requires reflective sheeting provided by manufacturer per D & OM (VIA) or a Type 3 Object Marker (OM-3) in front of the terminal end See D & OM (5) and D & OM (6)
Bridges with no Approach Rail	Type 3 Object Marker (OM-3) at end of rail and 3 single delineators approaching rail	See D & OM(5)
Reduced Width Approaches to Bridge Rail	Type 2 and Type 3 Object Markers (OM-3) and 3 single delineators approaching bridge	Requires reflective sheeting provided by manufacturer per D & OM (VIA) or a Type 3 Object Marker (OM-3) in front of the terminal end See D & OM (5)
Culverts without MBGF	Type 2 Object Markers	See Detail 2 on D & OM(4)
Crossovers	Double yellow delineators and RPMs	See Detail 1 on D & OM (4)
Pavement Narrowing (Lane merge) on Freeways/Expressway	Single delineators adjacent to affected lane for full length of transition	100 feet

NOTES

- Unless indicated otherwise, the delineator or barrier reflector color shall conform to the color of the pavement edge line on the side of the road where the delineators or barrier reflectors are placed.
- Barrier reflectors may be used to replace required delineators.
- Single red delineators may be mounted on the back side of delineator posts for wrong way driver applications

LEGEND	
	Bi-directional Delineator
	Delineator
	Sign

Traffic Safety Division Standard

DELINEATOR & OBJECT MARKER PLACEMENT DETAILS

D & OM(3)-20

FILE: dom3-20.dgn	DN: TXDOT	CK: TXDOT	DN: TXDOT	CK: TXDOT
© TXDOT	REVISED	CONT	SECT	JOB
3-15 9-15	8-15 7-20	6442	70	001
		DIST	COUNTY	US 96, ETC.
		LFK	SABINE	SHEET NO. 39

DISCLAIMER: The use of this standard is governed by the "Texas Engineering Practice Act". No warranty of any kind is made by TxDOT for any purpose whatsoever. TxDOT assumes no responsibility for the conversion of this standard into a contract or for any damages resulting from its use.

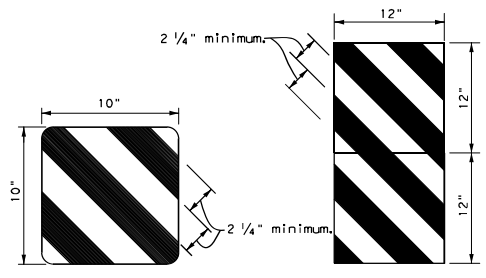
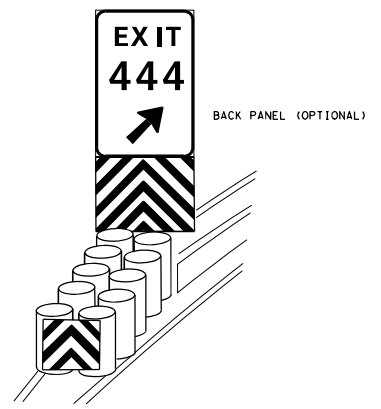
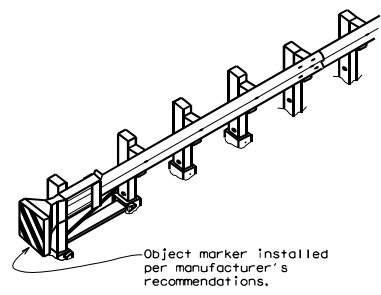
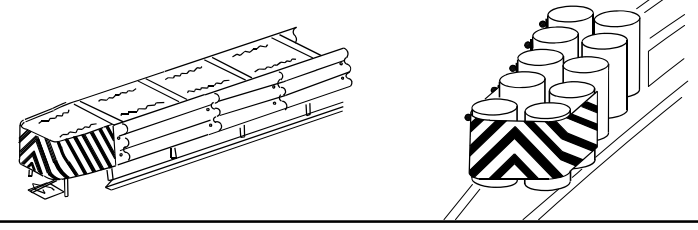
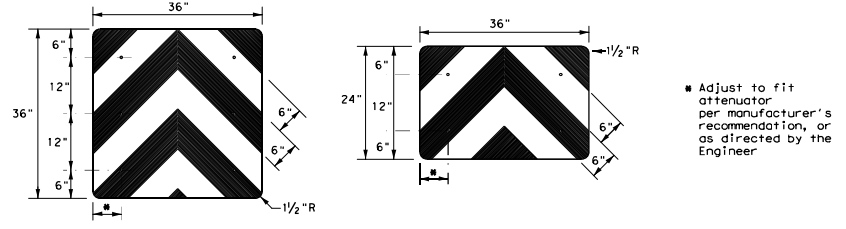
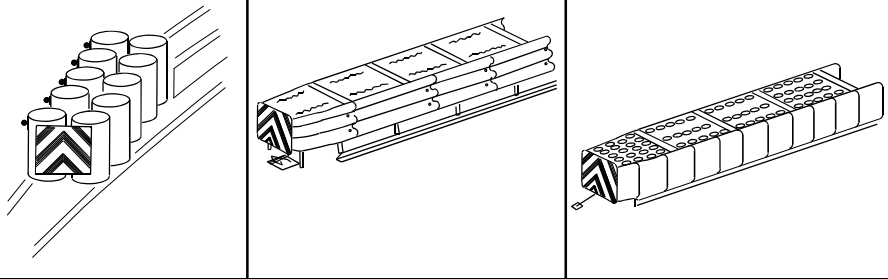

OBJECT MARKERS SMALLER THAN 3 FT²

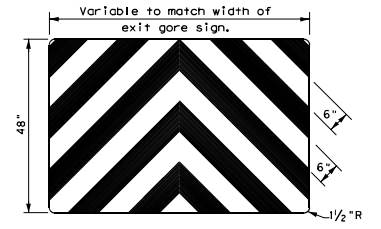

NOTES

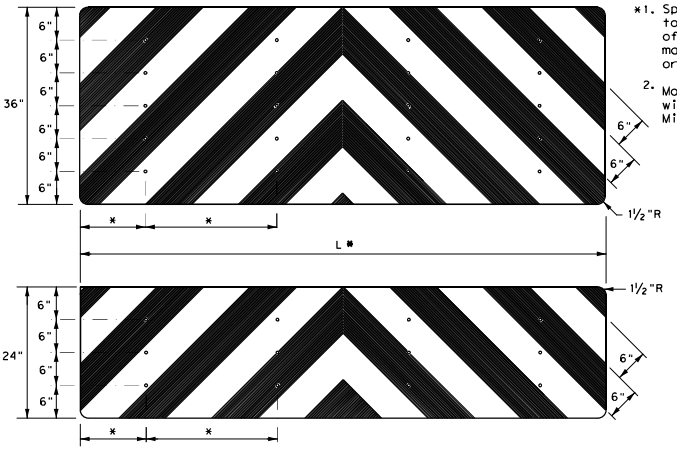

- *1. Spacing should be adjusted to attach through centerline of drum, per attenuator manufacturer's recommendation, or as directed by the Engineer.
- 2. Mounting should be flush with top of attenuator. Minimum size 96" x 24".

NOTES

1. Object Markers shall conform to the Texas MUTCD and meet the color and reflectivity requirement of Department Material Specification DMS 8300. Background shall be yellow reflective sheeting (Type B or C) and Chevron shall be black.
2. Object Markers may be fabricated from adhesive backed reflective sheeting applied directly to guardrail end treatment, or applied directly to an "end cap" as per the manufacturer's recommendation. Direct applied sheeting shall provide a smooth surface and have no wrinkles, air bubbles, cuts or tears. A radius at the corners is not required for direct applied sheeting.
3. Object Marker size may be reduced to fit smaller devices. Width of alternating black and yellow stripes are typically 6". Object Markers smaller than 3ft may have reduced width stripes of a minimum of 2 1/4".
4. Pop rivets, screws, or nuts and bolts may be used to attach object markers and reflectors. Holes, slots or other openings may be cut or drilled through object markers to allow cable or other attachments.
5. Object Marker at nose of attenuator is subsidiary to the attenuator.
6. See D & OM (1-4) for required barrier reflectors.

DATE: 4/12/2023 7:38:04 AM
 FILE: T:\LFK\DM\WgInt Contracts\0-RMC - Routine Maintenance Contracts\1723 of 1723.dgn

		Traffic Safety Division Standard	
DELINEATOR & OBJECT MARKER FOR VEHICLE IMPACT ATTENUATORS D & OM (VIA) - 20			
FILE: ddm\1a20.dgn	DN: TXDOT	CK: TXDOT	OK: TXDOT
© TXDOT December 1989	CONT SECT	JOB	HIGHWAY
4-92 8-04 REVISIONS	6442 70	001	US 96, ETC.
8-95 3-15	DIST	COUNTY	SHEET NO.
4-98 7-20	LFK	SABINE	40
206			

DISCLAIMER: This standard is covered by the "Texas Engineering Practice Act". No warranty of any kind is made by TxDOT for any purpose whatsoever. TxDOT assumes no responsibility for the conversion of this standard to other formats or for incorrect results or damages resulting from its use.

DATE: 4/12/2023
 FILE: T:\LFKDM\mnt Contracts\1723 Plans\6442-70-001 Sabine MBGF\DMG\STD\sgt1083116.dgn

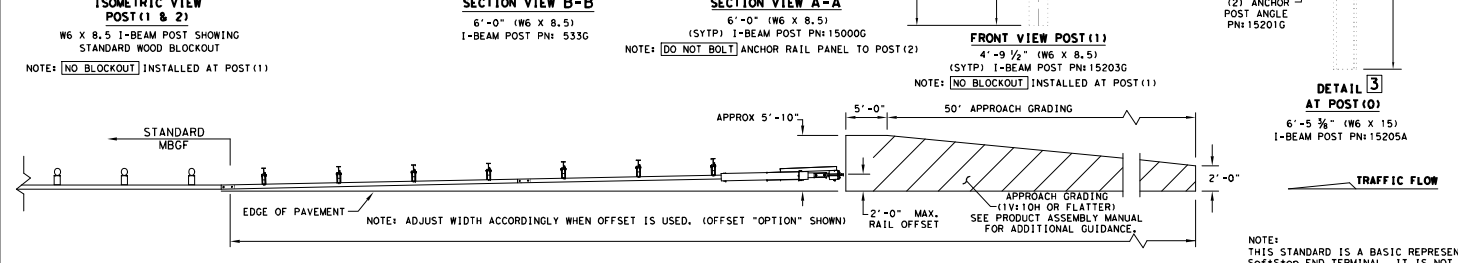
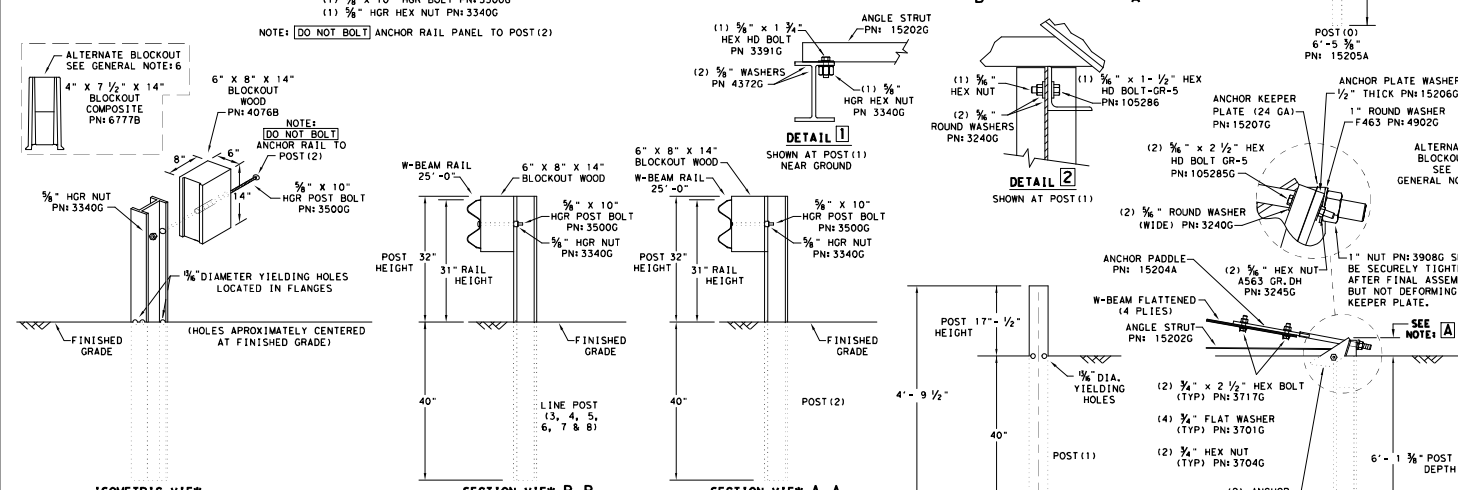
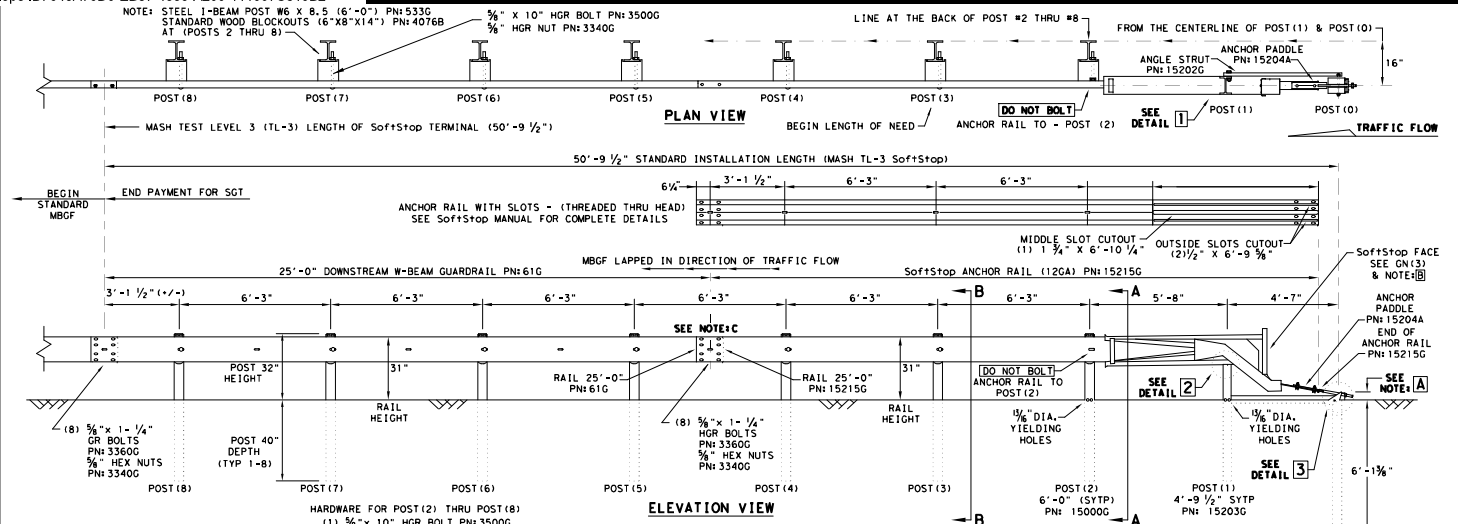

- GENERAL NOTES**
- FOR SPECIFIC INFORMATION REGARDING INSTALLATION AND TECHNICAL GUIDANCE OF THE SYSTEM, CONTACT: TRINITY HIGHWAY AT 1(888)323-6374, 2525 N. STEMMONS FREEWAY, DALLAS, TX 75207
 - FOR INSTALLATION, REPAIR AND MAINTENANCE REFER TO THE SoftStop END TERMINAL, PRODUCT DESCRIPTION ASSEMBLY MANUAL. PN: 620237B
 - APPLY HIGH INTENSITY REFLECTIVE SHEETING. OBJECT MARKERS ON THE FRONT FACE OF THE DEVICE PER MANUFACTURER'S RECOMMENDATIONS. OBJECT MARKER SHALL CONFORM TO THE STANDARDS REQUIRED IN TEXAS MUTCD.
 - FOR POST (LEAVE-OUT) INSTALLATION AND GUIDANCE SEE TxDOT'S LATEST ROADWAY MOW STRIP STANDARD.
 - HARDWARE (BOLTS, NUTS, & WASHERS) SHALL BE GALVANIZED IN ACCORDANCE WITH ITEM 445, "GALVANIZING". FITTINGS SHALL BE SUBSIDIARY TO THE BID ITEM.
 - A COMPOSITE MATERIAL BLOCKOUT THAT MEETS THE REQUIREMENTS OF DMS-7210, MAY BE SUBSTITUTED FOR BLOCKOUTS OF SIMILAR DIMENSIONS. SEE CONSTRUCTION DIVISION MATERIAL PRODUCER LIST (MPL) FOR CERTIFIED PRODUCERS.
 - IF SOLID ROCK IS ENCOUNTERED SEE THE MANUFACTURER'S INSTALLATION MANUAL AND REFER TO THE LATEST ROADWAY MBGF STANDARD FOR INSTALLATION GUIDANCE.
 - POSTS SHALL NOT BE SET IN CONCRETE.
 - IT IS ACCEPTABLE TO INSTALL THE SoftStop IMPACT HEAD PARALLEL TO THE GRADE LINE OR WITH AN UPWARD TILT.
 - DO NOT ATTACH THE SoftStop SYSTEM DIRECTLY TO A RIGID BARRIER.
 - UNDER NO CIRCUMSTANCES SHALL THE GUARDRAIL WITHIN THE SoftStop SYSTEM BE CURVED.
 - A FLARE RATE OF UP TO 25% MAY BE USED TO PREVENT THE TERMINAL HEAD FROM ENCRUCHING ON THE SHOULDER. THE FLARE MAY BE DECREASED OR ELIMINATED FOR SPECIFIC INSTALLATIONS, IF DIRECTED BY THE ENGINEER.

NOTE A THE INSTALLATION HEIGHT OF FULLY ASSEMBLED ANCHOR POST WILL VARY FROM 3 3/4" MIN. TO 4" MAX. ABOVE FINISHED GRADE.

NOTE B PART PN: 5852B RIGHT-SIDE (HIGH INTENSITY REFLECTIVE SHEETING) PART PN: 5851B LEFT-SIDE (HIGH INTENSITY REFLECTIVE SHEETING)

NOTE C W-BEAM SPLICE LOCATED BETWEEN LINE POST (4) AND LINE POST (5) GUARDRAIL PANEL 25'-0" PN: 61G ANCHOR RAIL 25'-0" PN: 15215G LAP GUARDRAIL IN DIRECTION OF TRAFFIC FLOW.

PART	QTY	MAIN SYSTEM COMPONENTS
620237B	1	PRODUCT DESCRIPTION ASSEMBLY MANUAL (LATEST REV.)
15208A	1	SoftStop HEAD (SEE MANUAL FOR RIGHT-LEFT APPROACH)
15215G	1	SoftStop ANCHOR RAIL (12GA) WITH CUTOUT SLOTS
61G	1	SoftStop DOWNSTREAM W-BEAM RAIL (12GA) (25'-0")
15205A	1	POST #0 - ANCHOR POST (6'-5 3/8")
15203G	1	POST #1 - (SYTP) (4'-9 1/2")
15000G	1	POST #2 - (SYTP) (6'-0")
533G	6	POST #3 THRU #8 - I-BEAM (W6 X 8.5) (6'-0")
4076B	7	BLOCKOUT - WOOD (ROUTED) (6" X 8" X 14")
6777B	7	BLOCKOUT - COMPOSITE (4" X 7 1/2" X 14")
15204A	1	ANCHOR PADDLE
15207G	1	ANCHOR KEEPER PLATE (24 GA)
15206G	1	ANCHOR PLATE WASHER (1/2" THICK)
15201G	2	ANCHOR POST ANGLE (10" LONG)
15202G	1	ANGLE STRUT
HARDWARE		
4902G	1	1" ROUND WASHER F436
3908G	1	1" HEAVY HEX NUT A563 GR.DH
3717G	2	3/4" X 2 1/2" HEX BOLT A325
3701G	4	3/4" ROUND WASHER F436
3704G	2	3/4" HEAVY HEX NUT A563 GR.DH
3360G	16	3/8" X 1 1/4" W-BEAM RAIL SPLICE BOLTS HGR
3340G	25	3/8" W-BEAM RAIL SPLICE NUTS HGR
3500G	7	3/8" X 10" HGR POST BOLT A307
3391G	1	3/8" X 1 1/2" HEX HD BOLT A325
4489G	1	3/8" X 9" HEX HD BOLT A325
4372G	4	3/4" WASHER F436
105285G	2	3/4" X 2 1/2" HEX HD BOLT GR-5
105286G	1	3/4" X 1 1/2" HEX HD BOLT GR-5
3240G	6	3/4" ROUND WASHER (WIDE)
3245G	3	3/8" HEX NUT A563 GR.DH
5852B	1	HIGH INTENSITY REFLECTIVE SHEETING - SEE NOTE B

**TRINITY HIGHWAY
SOFTSTOP END TERMINAL
MASH - TL-3
SGT (10S) 31-16**

FILE: sgt1083116	DN: TxDOT	CR: KM	DN: VP	CR: MB/VP
REVISIONS	CONT	SECT	JOB	HIGHWAY
6442	70	001	US 96	E.T.C.
DIST	COUNTY	CITY	SHEET NO.	
LFK	SABINE		41	

NOTE: THIS STANDARD IS A BASIC REPRESENTATION OF THE SoftStop END TERMINAL. IT IS NOT INTENDED TO REPLACE THE PRODUCT DESCRIPTION ASSEMBLY MANUAL.

DISCLAIMER: The use of this standard is governed by the "Texas Engineering Practice Act". No warranty of any kind is made by TxDOT for any purpose whatsoever. TxDOT assumes no responsibility for the conversion of this standard to digital format or for any errors or omissions that may appear hereon.

DATE: 4/12/2023
 FILE: T:\LFDK\MAINT\ Contracts\0-RMC - Routine Maintenance Contracts\FY23 of Highways\0001\0001.dgn

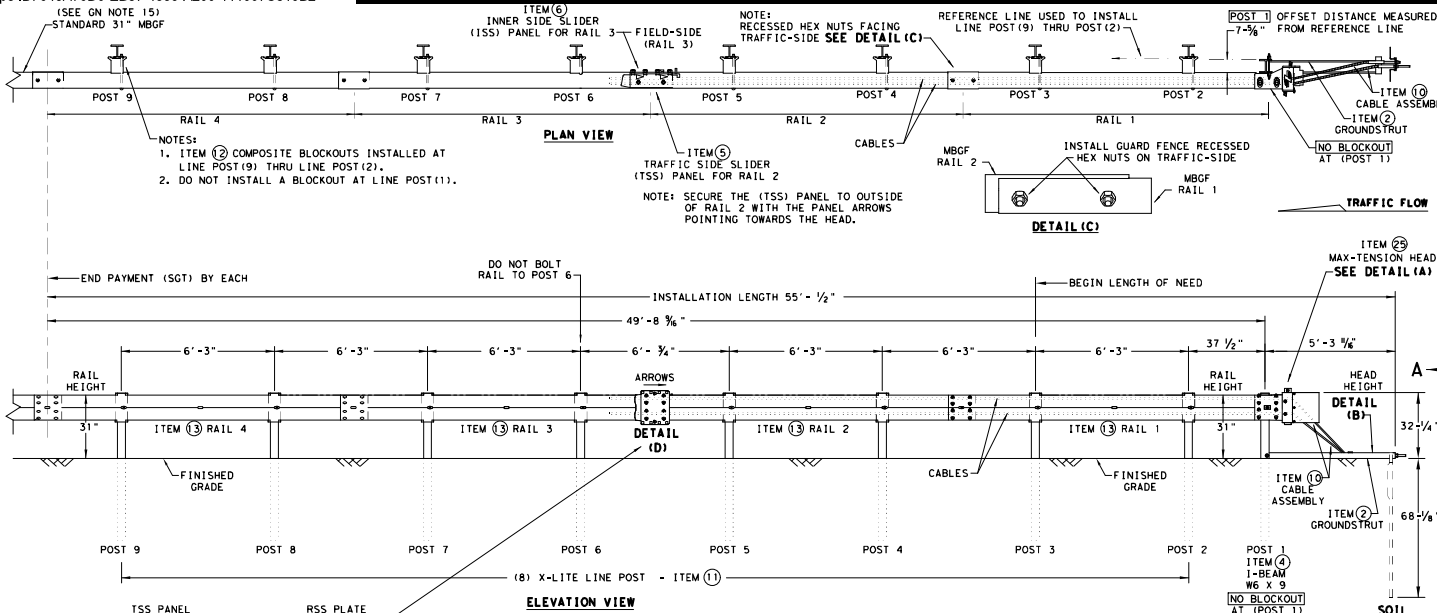

- GENERAL NOTES**
- FOR SPECIFIC INFORMATION REGARDING INSTALLATION AND TECHNICAL GUIDANCE OF THE SYSTEM, CONTACT: LINDSAY TRANSPORTATION SOLUTIONS (LTS) - BARRIER SYSTEMS, INC. AT (707) 374-6800
 - FOR INSTALLATION, REPAIR, & MAINTENANCE REFER TO THE MAX-TENSION INSTALLATION INSTRUCTION MANUAL, P/N MANMAX REV D (ECN 3516).
 - APPLY HIGH INTENSITY REFLECTIVE SHEETING, "OBJECT MARKER" ON THE FRONT FACE OF THE DEVICE PER MANUFACTURER'S RECOMMENDATIONS. OBJECT MARKER SHALL CONFORM TO THE STANDARDS REQUIRED IN TEXAS MUTCD.
 - FOR POST (LEAVE-OUT) INSTALLATION AND GUIDANCE SEE TxDOT'S LATEST ROADWAY MOW STRIP STANDARD.
 - ALL STEEL COMPONENTS ARE GALVANIZED PER ASTM A123 OR EQUIVALENT UNLESS OTHERWISE STATED.
 - SYSTEM SHOWN USING STEEL WIDE FLANGE POST WITH COMPOSITE BLOCKOUTS.
 - COMPOSITE MATERIAL BLOCKOUT THAT MEETS THE REQUIREMENTS OF DMS-7210, MAY BE SUBSTITUTED FOR BLOCKOUTS SIMILAR DIMENSIONS. SEE CONSTRUCTION DIVISION MATERIAL PRODUCER LIST (MPL) FOR CERTIFIED PRODUCERS.
 - REFER TO INSTALLATION MANUAL FOR SPECIFIC PANEL LAPPING GUIDANCE.
 - IF SOLID ROCK IS ENCOUNTERED SEE THE MANUFACTURER'S INSTALLATION MANUAL FOR INSTALLATION GUIDANCE.
 - POSTS SHALL NOT BE SET IN CONCRETE.
 - A DRIVING CAP WITH A TIMBER OR PLASTIC INSERT SHALL BE USED WHEN DRIVING POST TO PREVENT DAMAGE TO THE GALVANIZING ON TOP OF THE POST.
 - MAX-TENSION SYSTEM SHALL NEVER BE INSTALLED WITHIN A CURVED SECTION OF GUARDRAIL.
 - IF A DELINEATION MARKER IS REQUIRED, MARKER SHALL BE IN ACCORDANCE WITH TEXAS MUTCD.
 - THE SYSTEM IS SHOWN WITH 12'-6" MBGF PANELS, 25'-0" MBGF PANELS ARE ALSO ALLOWED.
 - A MINIMUM OF 12'-6" OF 12GA. MBGF IS REQUIRED IMMEDIATELY DOWNSTREAM OF THE MAX-TENSION SYSTEM.

ITEM #	PART NUMBER	DESCRIPTION	QTY
1	BS1-1610060-00	SOIL ANCHOR - GALVANIZED	1
2	BS1-1610061-00	GROUND STRUT - GALVANIZED	1
3	BS1-1610062-00	MAX-TENSION IMPACT HEAD	1
4	BS1-1610063-00	W6x9 I-BEAM POST 6FT., GALVANIZED	1
5	BS1-1610064-00	TSS PANEL - TRAFFIC SIDE SLIDER	1
6	BS1-1610065-00	ISS PANEL - INNER SIDE SLIDER	1
7	BS1-1610066-00	TOOTH - GEOMET	1
8	BS1-1610067-00	RSS PLATE - REAR SIDE SLIDER	1
9	B061058	CABLE FRICTION PLATE - HEAD UNIT	1
10	BS1-1610069-00	CABLE ASSEMBLY - MASH X-TENSION	2
11	BS1-1012078-00	X-LITE LINE POST-GALVANIZED	8
12	B090534	8" W-BEAM COMPOSITE-BLOCKOUT XT110	8
13	BS1-4004386	12'-6" W-BEAM GUARD FENCE PANELS 12GA.	4
14	BS1-1102027-00	X-LITE SQUARE WASHER	1
15	BS1-2001886	3/8" x 7" THREAD BOLT HH (GR.5) GEOMET	1
16	BS1-2001885	3/4" x 3" ALL-THREAD BOLT HH (GR.5) GEOMET	4
17	4001115	3/8" x 1 1/2" GUARD FENCE BOLTS (GR.2)MGAL	48
18	2001840	3/8" x 10" GUARD FENCE BOLTS MGAL	8
19	2001636	3/8" WASHER F436 STRUCTURAL MGAL	2
20	4001116	3/8" RECESSED GUARD FENCE NUT (GR.2)MGAL	59
21	BS1-2001888	3/8" x 2" ALL THREAD BOLT (GR.5)GEOMET	1
22	BS1-1701063-00	DELINEATION MOUNTING (BRACKET)	1
23	BS1-2001887	1/4" x 3/4" SCREW SD HH 410SS	7
24	4002051	GUARDRAIL WASHER RECT AASHTO FW903	1
25	SEE NOTE BELOW	HIGH INTENSITY REFLECTIVE SHEETING	1
26	4002337	8" W-BEAM TIMBER-BLOCKOUT, POB018	8
27	BS1-4004431	25' W-BEAM GUARDRAIL PANEL, 8-SPACE, 12GA.	2
28	MANMAX Rev-(D)	MAX-TENSION INSTALLATION INSTRUCTIONS	1

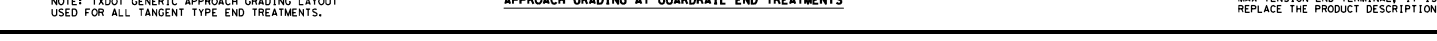
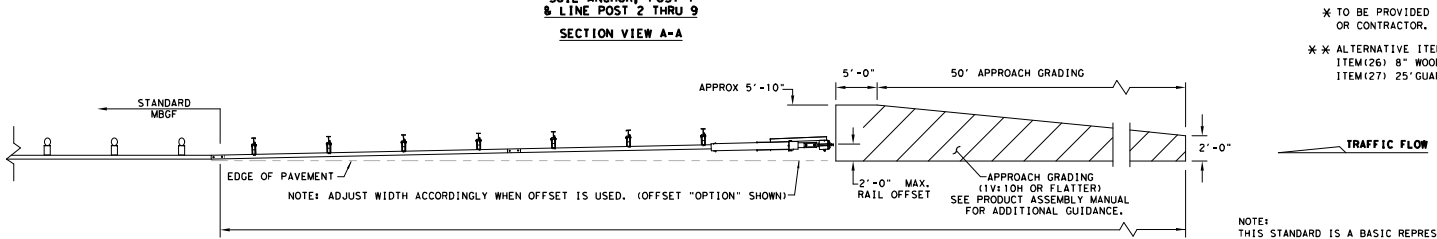
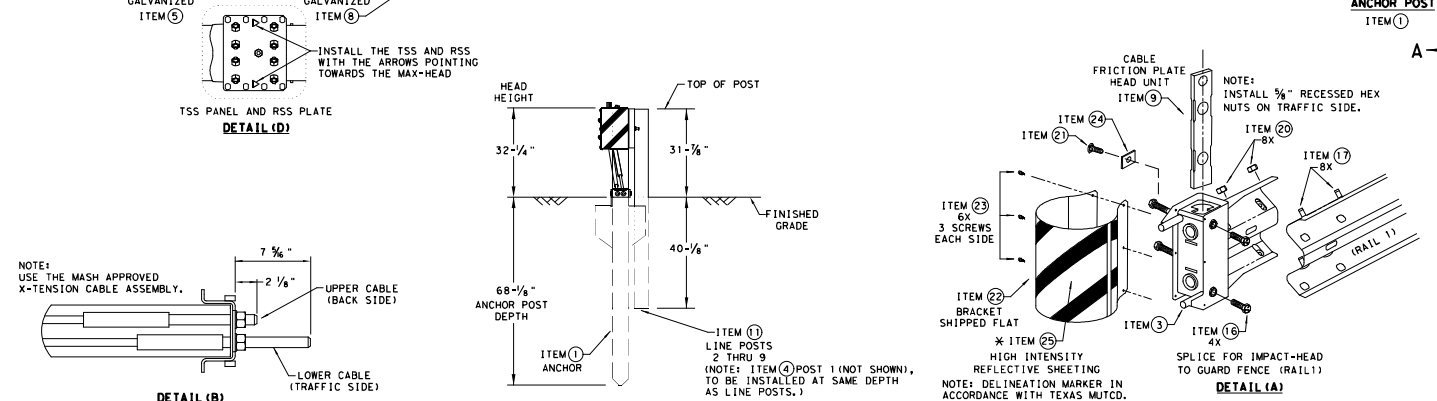

NOTE: TxDOT GENERIC APPROACH GRADING LAYOUT USED FOR ALL TANGENT TYPE END TREATMENTS.

NOTE: THIS STANDARD IS A BASIC REPRESENTATION OF THE MAX-TENSION END TERMINAL, IT IS NOT INTENDED TO REPLACE THE PRODUCT DESCRIPTION ASSEMBLY MANUAL.

Texas Department of Transportation
 Design Division Standard

MAX-TENSION END TERMINAL
MASH - TL-3
SGT(11S)31-18

FILE: 8gt1183118.dgn DWG: TxDOT CHK: KM DWG: TxDOT CHK: CL
 © TxDOT: FEBRUARY 2018 CONT: SECT JOB: HIGHWAY
 REVISIONS: 6442 TO 001 US 96, ETC.
 DIST: COUNTY SHEET NO.
 LFK CABINE 42

DISCLAIMER: THIS STANDARD IS GOVERNED BY THE "TEXAS ENGINEERING PRACTICE ACT". NO WARRANTY OF ANY KIND IS MADE BY TXDOT FOR ANY PURPOSE WHATSOEVER. TXDOT ASSUMES NO RESPONSIBILITY FOR THE CONVERSION OF THIS STANDARD TO OTHER FORMATS OR FOR INCORRECT RESULTS OR DAMAGES RESULTING FROM ITS USE.

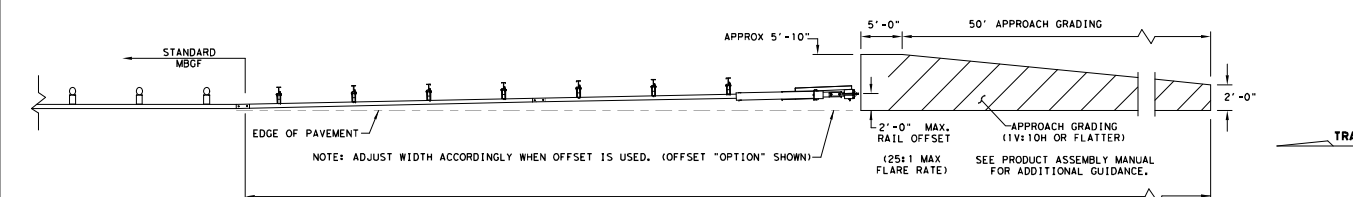
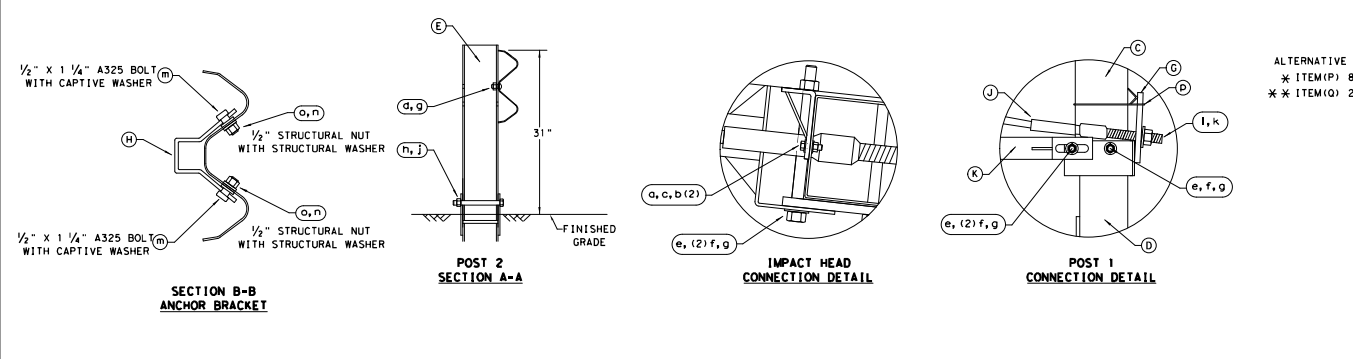
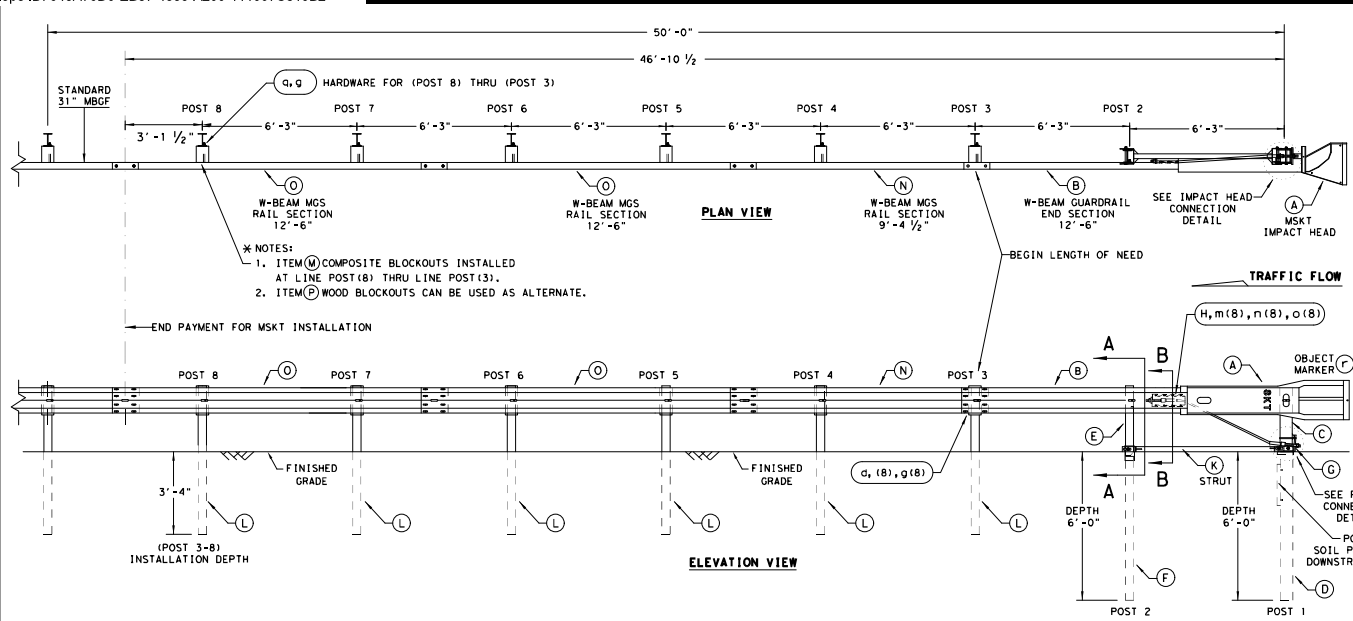

NOTE: TXDOT GENERIC APPROACH GRADING LAYOUT USED FOR ALL TANGENT TYPE END TREATMENTS.

NOTE: THIS STANDARD IS A BASIC REPRESENTATION OF THE MSKT END TERMINAL, IT IS NOT INTENDED TO REPLACE THE PRODUCT DESCRIPTION ASSEMBLY MANUAL.

GENERAL NOTES

- FOR SPECIFIC INFORMATION REGARDING INSTALLATION AND TECHNICAL GUIDANCE OF THE SYSTEM, CONTACT: ROAD SYSTEMS, INC. (432)263-2435, 3616 OLD HOWARD COUNTY AIRPORT, BIG SPRING, TX 79720
- FOR INSTALLATION, REPAIR AND MAINTENANCE REFER TO THE: MSKT END TERMINAL, PRODUCT DESCRIPTION ASSEMBLY MANUAL (PUBLICATION-062717).
- APPLY HIGH INTENSITY REFLECTIVE SHEETING, "OBJECT MARKER" ON THE FRONT FACE OF THE DEVICE PER MANUFACTURER'S RECOMMENDATIONS. "OBJECT MARKER SHALL CONFORM TO THE STANDARDS REQUIRED IN TEXAS MUTCD.
- FOR POST (LEAVE-OUT) INSTALLATION AND GUIDANCE SEE TXDOT'S LATEST ROADWAY MOW STRIP STANDARD.
- HARDWARE (BOLTS, NUTS, & WASHERS) SHALL BE GALVANIZED IN ACCORDANCE WITH ITEM 445, "GALVANIZING". FITTINGS SHALL BE SUBSIDIARY TO THE BID ITEM.
- SYSTEM SHOWN USING STEEL WIDE FLANGE POSTS WITH COMPOSITE BLOCKOUTS.
- A COMPOSITE MATERIAL BLOCKOUTS THAT MEETS THE REQUIREMENTS OF DMS-7210, MAY BE SUBSTITUTED FOR BLOCKOUTS OF SIMILAR DIMENSIONS. SEE CONSTRUCTION DIVISION MATERIAL PRODUCER LIST (MPL) FOR CERTIFIED PRODUCERS.
- IF SOLID ROCK IS ENCOUNTERED IN THE AREA OF (POST 1) AND / OR (POST 2) CONTACT THE MANUFACTURER, & REFER TO THE LATEST ROADWAY MBGF STANDARD FOR INSTALLATION GUIDANCE.
- POSTS SHALL NOT BE SET IN CONCRETE.
- SYSTEM MUST BE ATTACHED TO STANDARD 31" MBGF.
- UNDER NO CIRCUMSTANCES SHALL THE GUARDRAIL WITHIN THE MSKT SYSTEM BE CURVED.
- A FLARE RATE OF UP TO 25:1 MAY BE USED TO PREVENT THE TERMINAL HEAD FROM ENCRANCHING ON THE SHOULDER, THE FLARE MAY BE DECREASED OR ELIMINATED FOR SPECIFIC INSTALLATIONS, IF DIRECTED BY THE ENGINEER.
- THE SYSTEM IS SHOWN WITH TWO 12'-6" MBGF PANELS, ONE 25'-0" MBGF PANEL IS ALSO ALLOWED IN THEIR PLACE.
- A DRIVING CAP WITH A TIMBER OR PLASTIC INSERT SHALL BE USED WHEN DRIVING POSTS 3-8 TO PREVENT DAMAGE TO THE GALVANIZING ON TOP OF THE POST. SPECIAL DRIVING CAP TO BE USED ON LOWER POSTS 1 & 2 TO PREVENT DAMAGE TO THE WELDED PLATES.

ITEM	QTY	MAIN SYSTEM COMPONENTS	ITEM NUMBERS
A	1	MSKT IMPACT HEAD	MS3000
B	1	W-BEAM GUARDRAIL END SECTION, 12 Gg.	SF1303
C	1	POST 1 - TOP (6" X 6" X 1/4" TUBE)	MTPHP1A
D	1	POST 1 - BOTTOM (6" W6X15)	MTPHP1B
E	1	POST 2 - ASSEMBLY TOP	UHP2A
F	1	POST 2 - ASSEMBLY BOTTOM (6" W6X9)	HP2B
G	1	BEARING PLATE	E750
H	1	CABLE ANCHOR BOX	S760
J	1	BCT CABLE ANCHOR ASSEMBLY	E770
K	1	GROUND STRUT	MS785
L	6	W6x9 OR W6x8.5 STEEL POST	P621
M	6	COMPOSITE BLOCKOUTS	CBSP-14
N	1	W-BEAM MGS RAIL SECTION (9'-4 1/2")	G12025
O	2	W-BEAM MGS RAIL SECTION (12'-6")	G1203A
P	6	WOOD BLOCKOUT 6" X 8" X 14"	P675
Q	1	W-BEAM MGS RAIL SECTION (25'-0")	G1209

SMALL HARDWARE			
o	2	3/8" x 1" HEX BOLT (GRD 5)	B5160104A
b	4	3/8" WASHER	W0516
c	2	3/8" HEX NUT	N0516
d	25	3/8" Dia. x 1 1/4" SPLICE BOLT (POST 2)	B580122
e	2	3/8" Dia. x 9" HEX BOLT (GRD A449)	B580904A
f	3	3/8" WASHER	W050
g	33	3/8" Dia. H.G.R. NUT	N050
n	1	3/4" Dia. x 8 1/2" HEX BOLT (GRD A449)	B340854A
j	1	3/4" Dia. HEX NUT	N030
k	2	1 ANCHOR CABLE HEX NUT	N100
l	2	1 ANCHOR CABLE WASHER	W100
m	8	1/2" x 1 1/4" A325 BOLT WITH CAPTIVE WASHER	SB12A
n	8	1/2" STRUCTURAL NUTS	NO12A
o	8	1 1/4" O.D. x 3/8" I.D. STRUCTURAL WASHERS	WO12A
d	1	BEARING PLATE RETAINER TIE	CT-1005T
q	6	3/4" x 10" H.G.R. BOLT	B581002
r	1	OBJECT MARKER 18" X 18"	E3151

Design Division Standard

SINGLE GUARDRAIL TERMINAL

MSKT-MASH-TL-3

SGT (12S) 31-18

FILE: sgt12s3118.dgn	DN: TXDOT	CR: KM	DW: VP	CK: CL
© TXDOT: APRIL 2018	CONT: 70	SECT: 001	JOB: US 96, ETC.	HIGHWAY: 43
REVISIONS:	DIST: LFK	COUNTY: SABINE	SHEET NO.:	

GENERAL NOTES

1. THE TYPE OF POST (ROUND WOOD POST, RECTANGULAR WOOD POST, OR STEEL POST) WILL BE AS SHOWN IN THE PLANS. THE EXACT POSITION OF MBGF SHALL BE AS SHOWN IN THE PLANS OR AS DIRECTED BY THE ENGINEER. STEEL POSTS TO BE GALVANIZED IN ACCORDANCE WITH ITEM 445, "GALVANIZING."
2. RAIL ELEMENT SHALL MEET THE REQUIREMENTS OF ITEM 540, "METAL BEAM GUARD FENCE" EXCEPT AS MODIFIED IN THE PLANS. THE CONTRACTOR MAY FURNISH RAIL ELEMENTS OF 25'-0", OR 12'-6" (NOM.) LENGTHS. RAIL ELEMENTS MAY HAVE SLOTTED HOLES AT 3'-1 1/2" C-C OR 6'-3" C-C. A SPECIAL LENGTH OF RAIL MAY BE MANUFACTURED TO ACCOMMODATE THE TRANSITION SECTIONS OF GUARDRAIL.
3. BUTTON HEAD "POST" BOLTS (ASTM A307) SHALL BE OF SUFFICIENT LENGTH TO EXTEND THROUGH THE FULL THICKNESS OF THE NUT (ASTM A563) AND 3/8" ROUND WASHER (ASTM F436) AND NOT MORE THAN 1" BEYOND IT. BUTTON HEAD "SPLICE" BOLTS (ASTM A307) ARE 3/8" X 1-1/4" WITH 3/8" NUTS (ASTM A563).
4. FITTINGS (BOLTS, NUTS, AND WASHERS) SHALL BE GALVANIZED IN ACCORDANCE WITH ITEM 445, "GALVANIZING." FITTINGS SHALL BE SUBSIDIARY TO THE BID ITEM REQUIRING CONSTRUCTION OF THE TRANSITION.
5. CROWN SHALL BE WIDENED TO ACCOMMODATE THE METAL BEAM GUARD FENCE.
6. THE LATERAL APPROACH TO THE GUARD FENCE, SHALL HAVE A MAXIMUM SLOPE OF 1V:10H.
7. IF SHOWN ELSEWHERE IN THE PLANS OR AS DIRECTED BY THE ENGINEER, THE GUARD FENCE MAY BE FLARED AT A RATE OF 25:1 OR FLATTER.
8. APPLICATIONS IN SOLID ROCK ARE ONLY ALLOWED WITH STEEL POSTS. SEE GF (31) STANDARD FOR INSTALLATION GUIDANCE.
9. POSTS SHALL NOT BE SET IN CONCRETE.
10. UNLESS OTHERWISE SHOWN IN THE PLANS, A COMPOSITE MATERIAL BLOCK THAT MEETS THE REQUIREMENTS OF DMS-7210, "COMPOSITE MATERIAL POSTS AND BLOCKS FOR METAL BEAM GUARD FENCE" MAY BE SUBSTITUTED FOR BLOCKS OF SIMILAR DIMENSIONS. THE CONSTRUCTION DIVISION, TXDOT MAINTAINS A MATERIAL PRODUCER LIST (MPL) FOR PRODUCERS OF MATERIALS CONFORMING TO DMS-7210. ONLY PRODUCERS ON THE MPL MAY FURNISH COMPOSITE MATERIAL BLOCKS.
11. REFER TO STANDARD GF (31) FOR ADDITIONAL DETAILS.
12. RAIL HEIGHT ADJUSTMENT IS ASSESSED AT TL-3 MASH COMPLIANT FOR STEEL POST HEIGHT TRANSITION TO 28" STEEL POST GUARDRAIL.

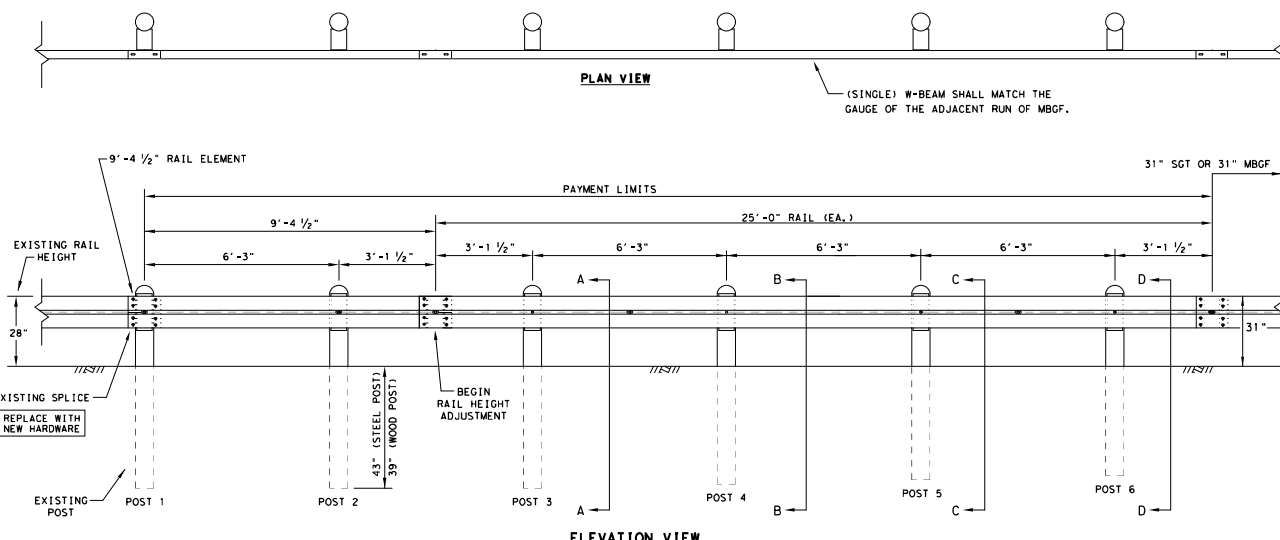

ELEVATION VIEW

* "WOOD" INDICATES DIMENSIONS FOR BOTH ROUND AND RECTANGULAR WOOD POST SYSTEMS.

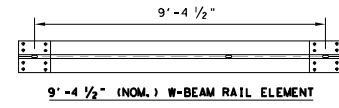
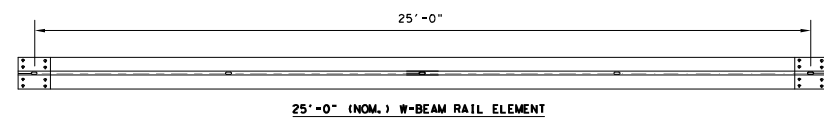
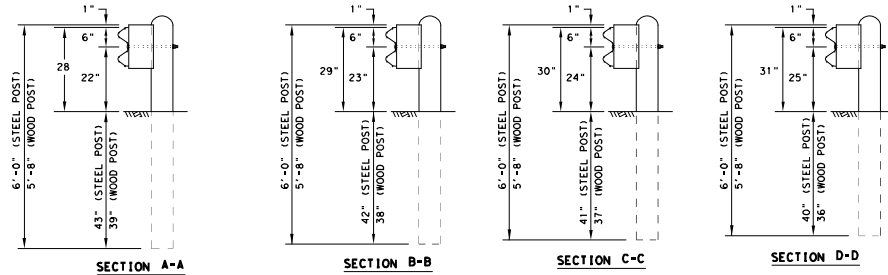

HARDWARE LIST	
QTY	DESCRIPTION
1	9'-4 1/2" W-BEAM RAIL ELEMENT 12GA.
1	25'-0" W-BEAM RAIL ELEMENT 12GA. (TYP)
6	7 1/2" DIA X 6'-0" DOMED ROUND WOOD POSTS (TYP)
6	6" X 8" X 68" RECTANGULAR WOOD POSTS (TYP)
6	W6 X 8.5 OR W6 X 9 X 72" STEEL POSTS (TYP)
6	6" X 8" X 14" WOOD BLOCKS OR COMPOSITE (TYP)
6	3/8" X 18" GUARDRAIL BOLTS WITH NUTS (FBB04)
6	3/8" ROUND WASHERS (ASTM F436) (FWC16G)
6	3/8" X 10" GUARDRAIL BOLTS WITH NUTS (FBB03)
24	3/8" X 1-1/4" GUARDRAIL SPLICE BOLTS WITH DOUBLE RECESSED NUTS (ASTM A563) (FBB01)

POST AND BLOCK-OUT TYPES AVAILABLE

FOR WOOD POST

FOR STEEL POST

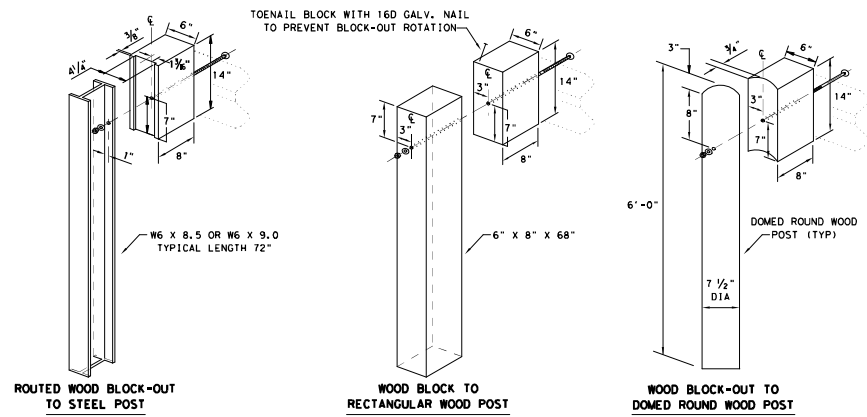

NOTE: HARDWARE SHALL MEET THE FOLLOWING REQUIREMENTS.

GUARDRAIL POST BOLTS (ASTM A307 GR. A)
 GUARDRAIL ROUND WASHERS (ASTM F436)
 GUARDRAIL DOUBLE RECESSED NUTS (ASTM A563)
 GUARDRAIL SPLICE BOLTS (ASTM A307 GR. A)
 GUARDRAIL SPLICE NUTS (ASTM A563)

Texas Department of Transportation
 Design Division Standard

**METAL BEAM GUARD FENCE
 RAIL HEIGHT ADJUSTMENT
 (28" TO 31")
 TL-3 MASH COMPLIANT
 RAIL-ADJ(A)-19**

FILE: r011ad019	DN:TXDOT	CK:KM	DR:VP	CK:GCL/AG
©TXDOT NOVEMBER 2019	CONT	SECT	JOB	HIGHWAY
REVISIONS	6442	70	001	US 96, ETC.
	DIST	COUNTY		SHEET NO.
	LFK	SABINE		44

DMS - Plans
 This use of this standard is governed by the "Texas Engineering Practice Act". No warranty of any kind is made by TxDOT for any purpose whatsoever. TxDOT assumes no responsibility for the conversion of units.

DATE: 4/12/2023 8:22:00 AM
 FILE: T:\LFDKDM\mnt\contracts\0-RMC - Routine Maintenance Contracts\FY23\plans\16547\16547-16547.dgn

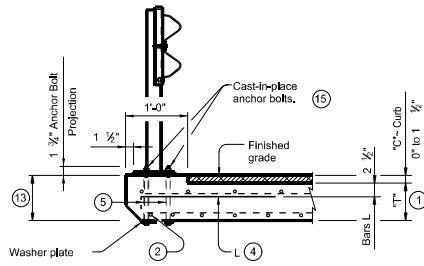

SECTION - TYPE 1
 Used for curbs 1 1/2" and Less
 (Showing "C" = 1 1/2")

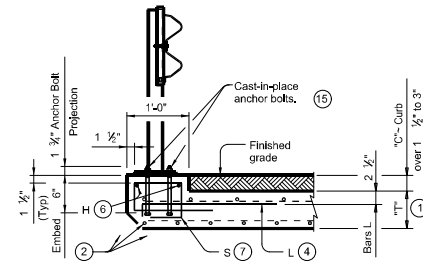

SECTION - TYPE 2
 Used for curbs over 1 1/2" to 3"
 (Showing "C" = 3")

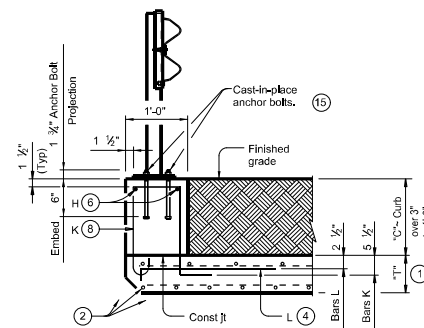

SECTION - TYPE 3
 Used for curbs over 3" to 1'-0"
 (Showing "C" = 1'-0")

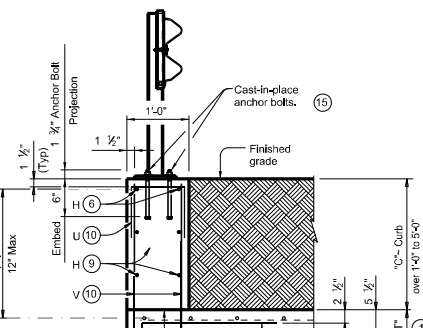

SECTION - TYPE 4
 Used for curbs over 1'-0" to 5'-0"
 (Showing "C" = 2'-0")

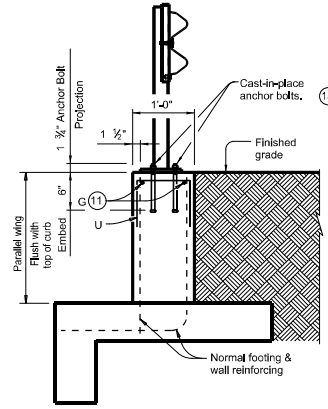

TYPICAL SECTION THRU PARALLEL WINGWALL
 Use with all curb heights shown.

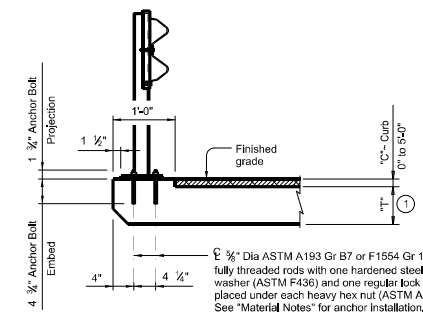

OPTIONAL ADHESIVE ANCHORAGE

Optional adhesive anchor may replace cast-in-place anchor bolts for Type 1 thru Type 4 and on Typical Section Thru Parallel Wingwalls. Reinforcement for optional adhesive anchorage matches details shown for Type 1 thru Type 4 and on Typical Section Thru Parallel Wingwalls.

- ① "T" is equal to the culvert top slab thickness. For precast boxes with slabs less than 8" thick, see SCP-MD standard for additional details.
- ② Adjust normal culvert slab bars as necessary to clear obstructions.
- ③ Omit normal culvert curb Bars K and H.
- ④ Place Bars L as shown. Tilt hook as necessary to maintain cover.
- ⑤ 4 formed holes for anchor bolts at each rail post. See rail standard for information not shown.
- ⑥ Place normal culvert curb Bars H (#4) as shown. Adjust as necessary to clear obstructions.
- ⑦ Omit normal culvert curb Bars K. Place Bars S as shown. Tilt Bars S as necessary to maintain cover.
- ⑧ Place normal culvert curb Bars K spaced at 12" Max as shown. Tilt Bars K as necessary to maintain cover. Refer to box culvert details sheets for Bars K details.
- ⑨ Additional Bars H (#4) as required to maintain 12" Max spa.
- ⑩ At TYPE 4 mountings, replace normal culvert curb Bars K with one Bar U and two Bars V as shown spaced at 12" Max. Adjust length of Bars V as necessary to maintain clear cover.
- ⑪ Adjust parallel wing Bars G to positions shown.
- ⑫ Optional Bars L are to be used only for precast box culverts with 3'-0" closure pour.
- ⑬ If "T" plus "C" is greater than 8", provide reinforcement per TYPE 1 mounting and anchor bolts per TYPE 2 mounting.
- ⑭ Quantities shown are for Contractor's information only. Quantities are per linear foot of curb length. The values for each section type in table can be interpolated for intermediate values of curb height, "C". Quantity includes Bars K (when applicable).
- ⑮ See "Cast-In-Place & Formed Hole Anchor Bolt Options".

1/2" Dia heavy hex head anchor bolt (ASTM F3125 Gr A325 or A449) or threaded rod (ASTM A193 Gr B7 or F1554 Gr 105) with one hardened steel washer (ASTM F436) and one regular lock washer placed under each heavy hex nut (ASTM A563). One additional heavy hex nut must be furnished and tack welded for each threaded rod.

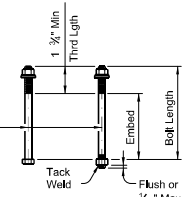

CAST-IN-PLACE & FORMED HOLE ANCHOR BOLT OPTIONS
 Applies to T631LS and T631 traffic rails.

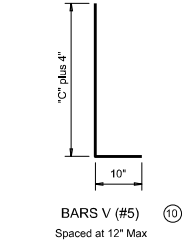

BARS V (#5)
 Spaced at 12" Max

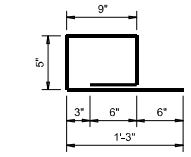

BARS S (#4)
 Spaced at 12" Max

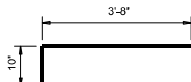

BARS L (#5)
 Spaced at 12" Max

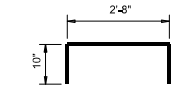

OPTIONAL BARS L (#5)
 Spaced at 12" Max

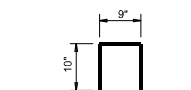

BARS U (#4)
 Spaced at 12" Max

TABLE OF ESTIMATED CURB QUANTITIES ⁽¹⁴⁾				
Curb Height "C"	Section Type	Conc (CY/LF)	Reinf Steel (Lb/LF)	
1 1/2"	1	0.005	4.7	
3"	2	0.009	8.4	
6"	3	0.019	8.9	
1'-0"	3	0.037	8.9	
1'-6"	4	0.056	14.3	
2'-0"	4	0.074	15.4	
2'-6"	4	0.093	17.7	
3'-0"	4	0.111	19.8	
3'-6"	4	0.130	21.2	
4'-0"	4	0.148	22.2	
4'-6"	4	0.167	24.6	
5'-0"	4	0.185	25.6	

CONSTRUCTION NOTES:
 For vehicle safety, finished grade must be flush with top of curb. Adjust reinforcing as necessary to provide 1 1/2" cover. At the Contractor's option, anchor bolts may be an adhesive anchor system. Test adhesive anchors in accordance with Item 450.3.3, "Tests". Test 3 anchors per 100 anchors installed. Perform corrective measures to provide adequate capacity if any of the tests do not meet the required test load. Repair damage from testing as directed.

MATERIAL NOTES:
 Provide concrete for curb of the same Class and strength as the box culvert top slab. Galvanize all steel components of steel rail system. Provide Grade 60 reinforcing steel. Galvanize all reinforcing steel if required elsewhere. Anchor bolts for base plate must be 1/2" Dia ASTM F3125 Gr A325 or A449 bolts (or ASTM A193 Gr B7 or F1554 Gr 105 threaded rods with one tack welded heavy hex nut each) with one hardened steel washer (ASTM F436) and one regular lock washer placed under each heavy hex nut. Nuts must conform to ASTM A563 requirements. Optional adhesive anchor system must be 1/2" Dia ASTM A193 Gr B7 or F1554 Gr 105 fully threaded rods with one hardened steel washer (ASTM F436) and one regular lock washer placed under each heavy hex nut. Nuts must conform to ASTM A563 requirements. Embed fully threaded rod into slab and/or abutment wingwall using a Type III, Class C, D, E, or F anchor adhesive. Minimum adhesive anchor embedment depth is 4 3/4". Anchor adhesive chosen must be able to achieve a nominal bond strength in tension of a single anchor. No. of 8 kips (edge distance must be accounted for). Submit signed and sealed calculations or the manufacturer's published literature showing the proposed anchor adhesive's ability to develop this load to the Engineer for approval prior to use. Anchor installation, including hole size, drilling, and clean out, must be in accordance with Item 450, "Railings".

GENERAL NOTES:
 Designed in accordance with AASHTO LRFD Bridge Design Specifications. See T631LS or T631 rail standard for approved speed restrictions, notes and details not shown. The curb is considered as part of the box culvert for payment. These details are for use with curbs that are 5'-0" tall and less only. Curb heights that are less than or greater than those shown will require special design.

Cover dimensions are clear dimensions, unless noted otherwise. Reinforcing bar dimensions shown are out-to-out of bar.

The use of the T631LS rail is restricted to speeds of 45 mph or less.

Bridge Division Standard

BOX CULVERT MOUNTING DETAILS FOR TYPE T631LS & T631 RAILS (CURBS 5' TALL AND LESS ONLY)

T631-CM

FILE: f1610420.dgn	DATE: TxDOT	CHK: TxDOT	DATE: JTR	DATE: AES
TxDOT February 2020 REV: rev06	COUNT: 6442	SHEET: 70	JOB: 001	HIGHWAY: US 96, ETC.
	BRIDGE: LFK	COUNTY: SABINE	SHEET NO.: 45	

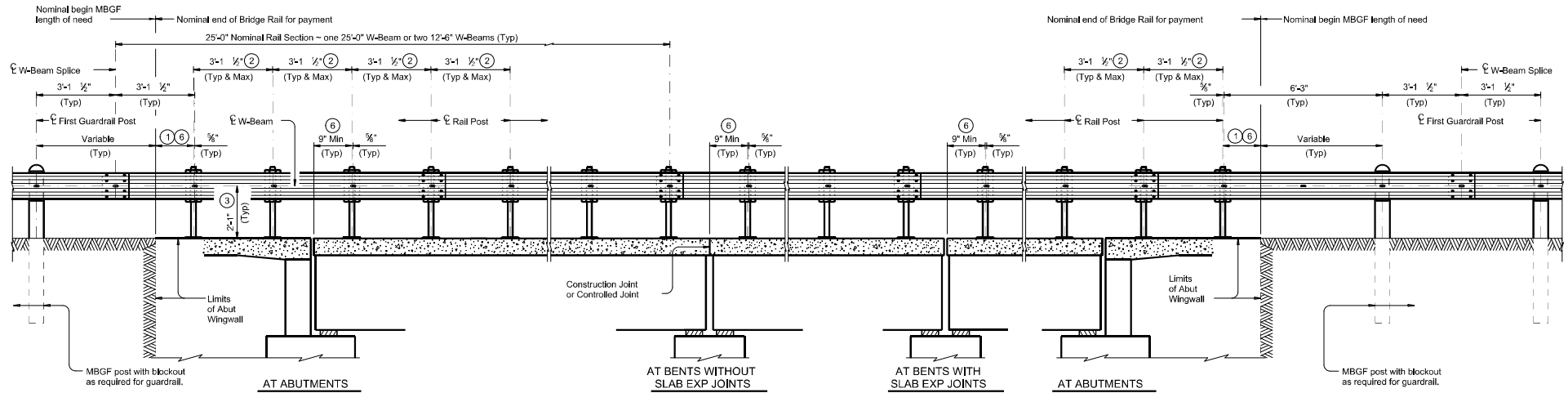

ROADWAY ELEVATION OF RAIL
Showing without overlay.

- ① 9" Min, 5'-0" Max
- ② Maintain 3'-1 1/2" Rail Post spacing wherever possible for use with nominal 25'-0" or 12'-6" W-Beam sections. Symmetry of post spacing on both sides and along the structure is not necessary.
- ③ Increase 2" for structures with overlay.
- ④ Tighten the first hex nut by hand until the top and bottom edges of the W-Beam engage the Backer Plate (Backer Plate should be snug against the post). Then tighten hex nut one revolution with wrench and secure with the second hex nut.
- ⑤ PL 1/2" x 1 1/2" x 1/4" with 3/8" Dia Hole centered in PL (ASTM A36). Square Guardrail Washer (FWR01).
- ⑥ The post nearest to a slab joint or end of structure may be shifted up to 9" in order to satisfy the minimum offset dimension. Drill a new 3/4" Dia hole in the centerline of W-beam for shifted post. Paint hole with two coats of zinc-rich paint conforming to the Item "Galvanizing". All other posts must remain on the typical spacing.
- ⑦ 3/4" Dia formed holes for 3/4" Dia heavy hex head anchor bolt (ASTM F3125 Gr A325 or A449) or threaded rod (ASTM A193 Gr B7 or F1554 Gr 105) with one hardened steel washer (ASTM F436) and one regular lock washer placed under heavy hex nut (ASTM A563). One additional heavy hex nut must be furnished and tack welded for each threaded rod. See "Cast-In-Place & Formed Hole Anchor Bolt Options".
- ⑧ 5/8" Dia heavy hex head anchor bolt (ASTM F3125 Gr A325 or A449) or threaded rod (ASTM A193 Gr B7 or F1554 Gr 105) with one hardened steel washer (ASTM F436) and one regular lock washer placed under heavy hex nut (ASTM A563). One additional heavy hex nut must be furnished and tack welded for each threaded rod. See "Cast-In-Place & Formed Hole Anchor Bolt Options".

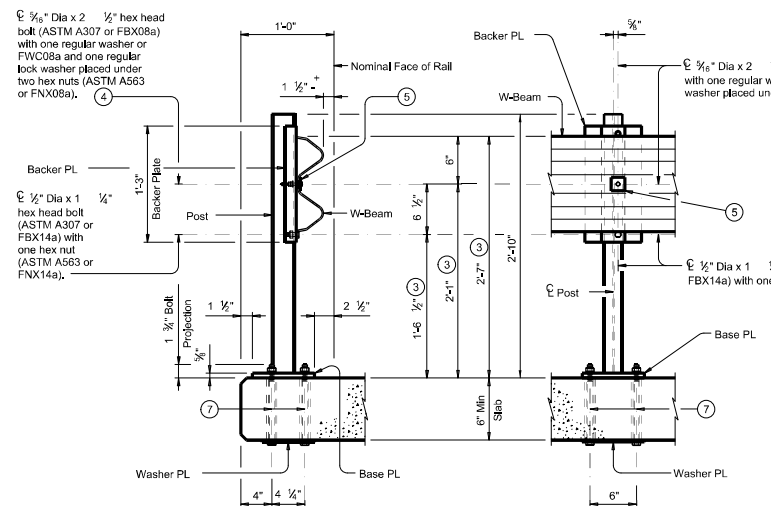

RAIL DETAILS ON BRIDGE SLAB
Showing without overlay.

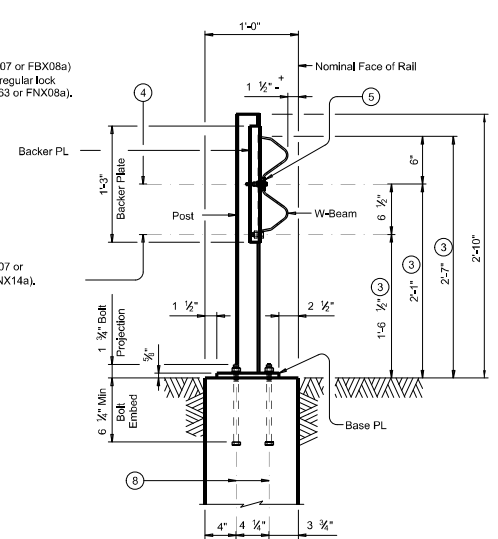

RAIL SECTION ON ABUTMENT WINGWALL
Showing without overlay.

DATE: 4/12/2023 8:22:01 AM
 FILE: T:\LFK\DM\mnt\contracts\0-RMC - Routine Maintenance Contracts\1723 - Highway 96\96-100\96-100-01.dwg
 DWG: ASES
 This use of this standard is governed by the "Texas Engineering Practice Act". No warranty of any kind is made by TxDOT for any purpose whatsoever. TxDOT assumes no responsibility for the conversation of this drawing.

SHEET 1 OF 2

Texas Department of Transportation

Bridge Division Standard

TRAFFIC RAIL

TYPE T631

FILE: flst03820.dgn	DATE: TxDOT	CHK: AES	DATE: JTR	CHK: AES
PROJECT: September 2019	CONTRACT: 6442	SHEET: 70	JOB: 001	HS-WAY: US 96, ETC.
DATE: 03-20-2019	BY: LFK	COUNTY: LFK	SHEET NO.: 46	

DISCLAIMER: This standard is covered by the "Texas Engineering Practice Act". No warranty of any kind is made by TxDOT for any purpose whatsoever. TxDOT assumes no responsibility for the conversion of this standard to other formats or for incorrect results or damages resulting from its use.

DATE: 4/12/2023 8:22:07 AM
 FILE: T:\LFK\DM\Int Contracts\0-RMC - Routine Maintenance Contracts\123 Plans\6442-70-001 Sabine MBEF.dgn\STD\bed14.dgn

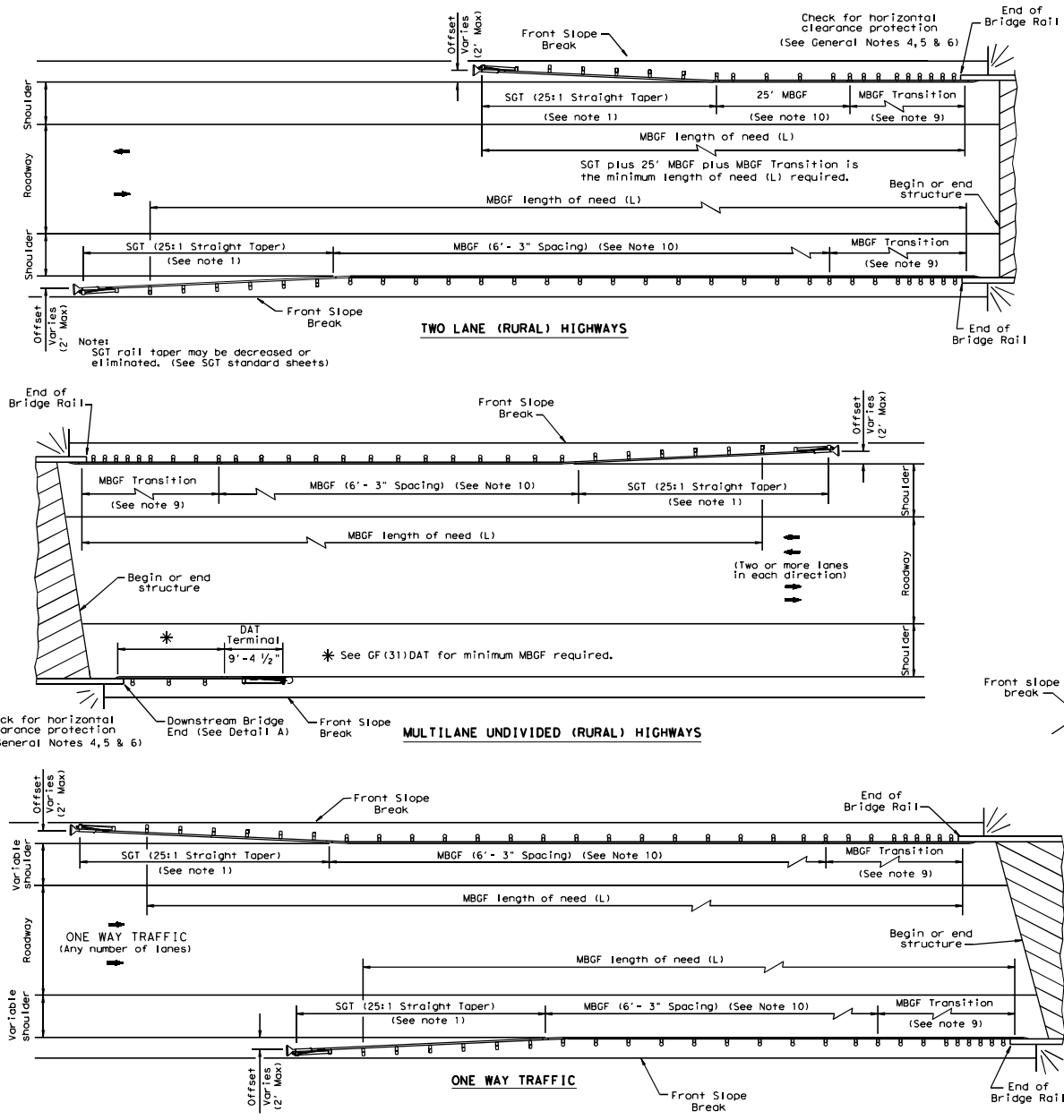

GENERAL NOTES

- For more detail: See GF (31), SGT (31), GF (31)TR, and GF (31)TL2 standard sheets.
- Quantities of metal beam guard fence (MBGF) at individual bridge ends are as shown in the plans.
- Use average daily traffic (ADT) for the current year to determine MBEF length of need in accordance with the Roadway Design Manual unless otherwise specified. Where significant traffic volume growth is anticipated on low volume (0-750 ADT) highways, use length determinations for the higher volume category.
- MBGF may not be required to shield departure end of bridge unless other obstacles within the horizontal clearance limits or opposing traffic indicate a MBEF consideration.
- Downstream anchor terminals (DAT) are only for downstream end anchorage use, outside the horizontal clearance area of opposing traffic.
- Direct connection of MBEF to concrete rails are only for downstream rail connections outside the horizontal clearance area of opposing traffic. (This requires a minimum of three standard line posts plus the DAT terminal, See Detail A)
- The crown shall be widened to accommodate MBEF. Typically the "front slope" break should be 2'-0" from the back of the MBEF post. This applies to new construction on new alignment or where existing roadway cross section is to be widened to increase roadway width. This does not apply to rehabilitation work where existing roadway crown width is to be retained (See Typical Cross Section at MBEF).
- For restrictive bridge widths: The MBEF should be properly transitioned from the existing bridge rail to the adjoining MBEF (See MBEF Transition Standards). Metal beam guard fence at these bridge location(s) shall be flared at the rate of 25:1 or flatter, and be of the length necessary to locate the terminal end at the 2 ft. "maximum" offset from the shoulder edge in the approach direction.
- Transition length and post spacing will vary depending on the transition type. Transition type will be shown elsewhere in the plans.
- A minimum 25' length of MBEF will be required.

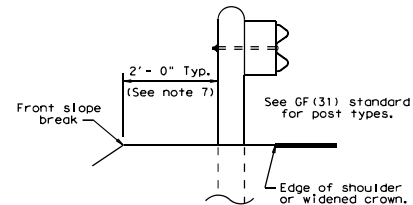

TYPICAL CROSS SECTION AT MBEF

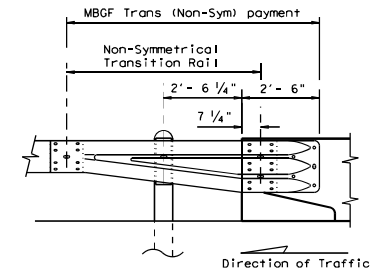

DETAIL A
Showing Downstream Rail Attachment

		Design Division Standard	
BRIDGE END DETAILS (METAL BEAM GUARD FENCE APPLICATIONS TO RIGID RAILS) BED-14			
FILE: bed14.dgn	DN: TxDOT	CR: AM	DN: BD/VP
© TxDOT: December 2011 REVISED APRIL 2014 REL: (NEW 04/14)	CONT SECT 6442 70	JOB 001 US 96, ETC.	C&C CGL HIGHWAY SHEET NO.
DIST	COUNTY	SHEET NO.	
LFK	SABINE	51	

DMS - MISC.
 This use of this standard is governed by the "Texas Engineering Practice Act". No warranty of any kind is made by TxDOT for any purpose whatsoever. TxDOT assumes no responsibility for the convention of the drawings.
 DATE: 4/12/2023 8:22:08 AM
 FILE: T:\LFDK\MOInt\Contracts\0-RMC - Routine MOIntence Contracts\1723 - Bridge\1723-19\1723-19.dgn

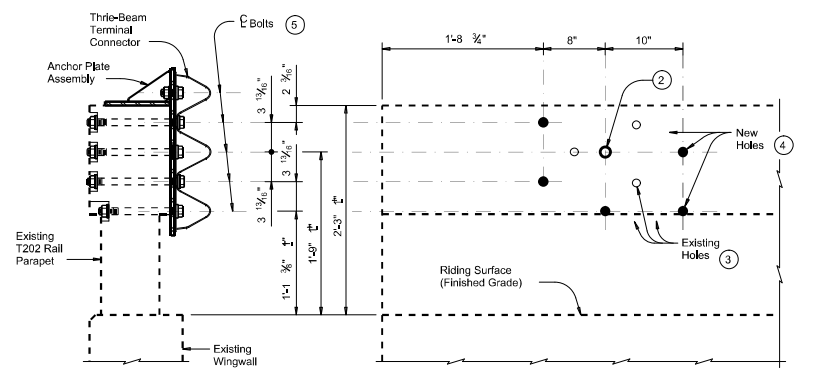
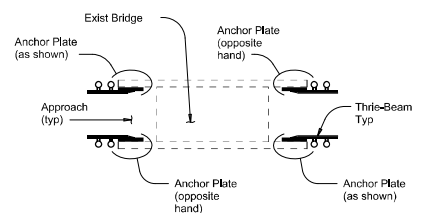
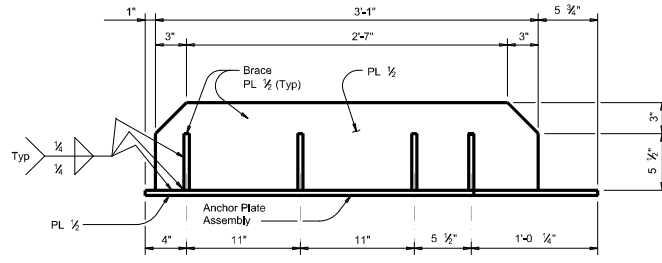

DETAILS OF BOLTS AND HOLES

CONSTRUCTION NOTES:
 Field verify dimensions before commencing work and ordering materials.
 Plugging of newly exposed existing bolt holes is not necessary except as stated here in or otherwise indicated on the plans. This work is considered subsidiary to the pertinent bid items.
 Attach the MBGF Transition to the existing parapet using the Anchor Plate assembly and the Thrie-Beam Terminal Connector. Splice the Thrie-Beam Terminal Connector to the Thrie-Beam with the normal 12 connection bolts. Refer to Metal Beam Guard Fence Transition and Metal Beam Guard Fence Detail sheets for additional details and information not shown herein.

MATERIAL NOTES:
 Fabricate Anchor Plate assembly with steel conforming to either ASTM A36 or A572 Gr 50. Anchor Plate assembly must be free of burrs, sharp edges and weld spatter. Grind edges and corners to a 1/8" flat or radius. Ho-clip galvanize Anchor Plate assembly in accordance with Item 445, "Galvanizing". Anchor bolts, nuts, and washers must conform to Item 449, "Anchor Bolts".

GENERAL NOTES:
 These details are for retrofitting existing rails only, not new construction, with a Thrie-Beam Terminal Connection.
 Shop drawings are not required for this installation.
 Payment for materials, fabrication, and installation of this assembly are to be included in unit price bid in accordance with Item 540 "M Bm Gd Fen Trans (Anchor Plate)".
 Estimated weight of a single Anchor Plate assembly, including bolts, nuts, and washers, but not including the Thrie-Beam Terminal Connector = 190 Lbs.

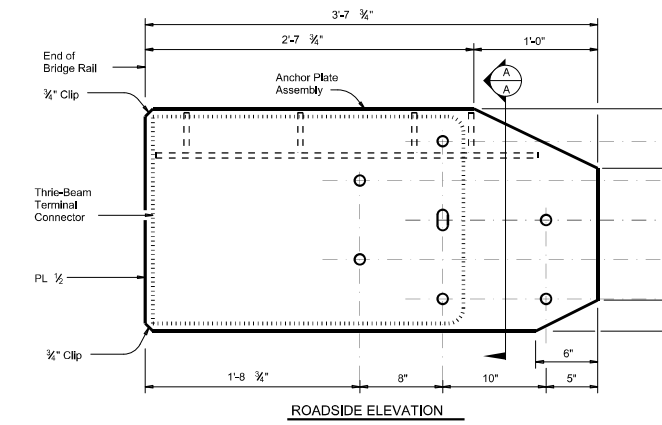

ANCHOR PLATE DETAILS

Anchor Plate shown is detailed for one end of one side of rail only. For other side, Anchor Plate must be built opposite hand.

BRACE PLATE DETAILS

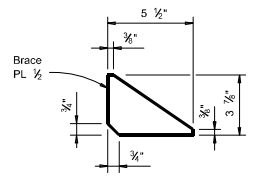

This sheet is intended as a guide in preparing job-specific details to retrofit existing T202 rails with a Thrie-Beam terminal connector. This sheet may not be used without modification. The details shown may need to be amended if the exact existing conditions are not covered. In all cases, details and notes not required are to be removed or crossed out, "MOD" added, and the phrase "Not to be used as a standard" removed from the title block. This sheet must be signed, sealed, and dated by a registered Professional Engineer. The effective height of the existing rail (at the Anchor Plate location) above the finished riding surface, as seen by an errant vehicle, must be between 2'-2" and 2'-4". Alternate methods of retrofit must be used for effective heights beyond these limits. Dimensions of existing rail height (traffic side) should be shown. Particular care should be taken in identifying existing rail conditions and providing for proper Anchorage Plate and MBGF transition positioning.

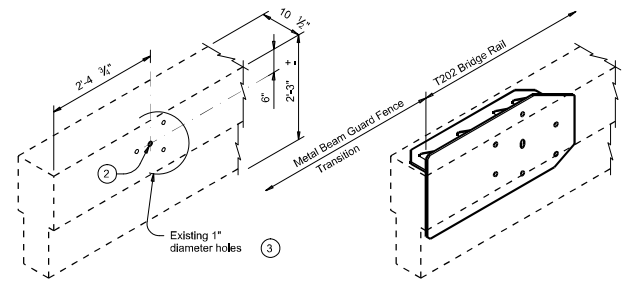

INSTALLATION DETAILS

- 1 The Contractor must verify that locations of bolt holes match those in the Thrie-Beam Terminal Connector to be installed in that location prior to fabrication of the Anchor Plate assembly and prior to coring bolt holes in the existing T202 parapet.
- 2 If the existing holes are aligned as expected, use the indicated existing 1" diameter hole in the installation of the Anchor Plate assembly and the Thrie-Beam Terminal Connector.
- 3 If the existing holes are not aligned as expected, holes that cannot be utilized in the installation and are within 3" of a new bolt hole must be filled with epoxy grout prior to coring new holes.
- 4 Drill new 1" diameter holes, each with a 2 1/2" diameter x 1" deep recess, through existing railing parapet. Recesses are only required when pedestrian sidewalks are adjacent to back of rail unless directed otherwise by the Engineer. Holes should be perpendicular to the roadside face of the parapet. Drill holes and recesses with coring type equipment. Percussion drilling is not allowed. Patch spalls, when directed by the Engineer, in accordance with Item 429, "Concrete Structure Repair", at the contractor's expense.
- 5 7 - 3/8" diameter ASTM F3125 Gr A325 Hex Head Anchor Bolts each with 2 - 1 1/2" O.D. washers. Place washer under each head and nut. Provide bolts of sufficient length to extend a minimum of 1/2" beyond nut. Cut excess bolt length and paint cut surface with zinc-paint if directed by the Engineer.

		Bridge Division Standard	
T202 TRANSITION RETROFIT GUIDE			
(NOT TO BE USED AS A STANDARD)			
T202TR			
FILE: f1812024-19.dgn	DATE: TxDOT	CHK: TxDOT	DATE: TxDOT
SEPTEMBER 2019	6442	70	001
COUNTY: LFK	COUNTY: LFK	COUNTY: LFK	COUNTY: LFK
SHEET NO. 52		HIGHWAY: US 96, ETC.	

DWS - AISC
 This use of this standard is governed by the "Texas Engineering Practice Act". No warranty of any kind is made by AISC for any purpose whatsoever. TxDOT assumes no responsibility for the conversion of units.

DATE: 4/12/2023 8:22:09 AM
 FILE: T:\LFK\DMG\Int\Contracts\0-RMC - Routine Maintenance\Contracts\1723 - Sabine\MBGF\T2/T201\T201R-53.dgn

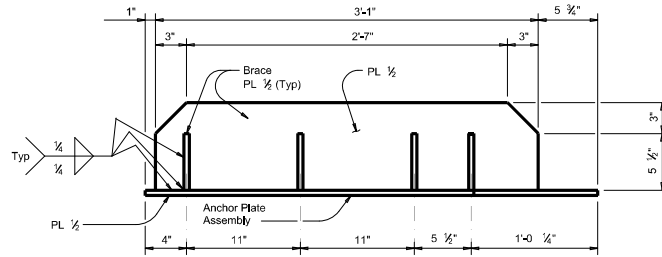

PLAN

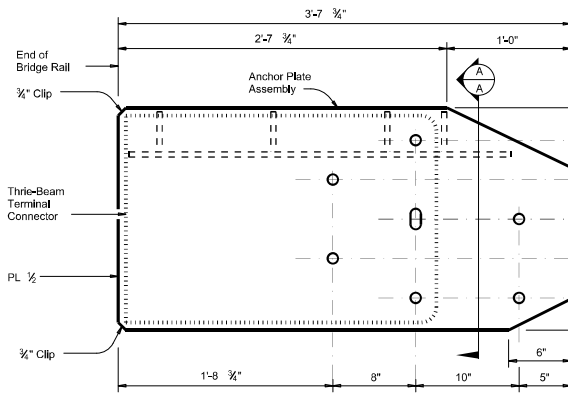

ROADSIDE ELEVATION

ANCHOR PLATE DETAILS

Anchor Plate shown is detailed for one end of one side of rail only. For other side, Anchor Plate must be built opposite hand.

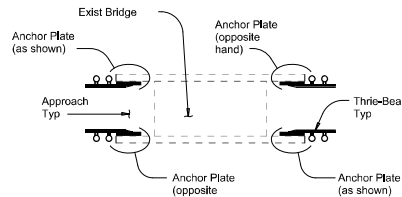

LOCATION DETAILS

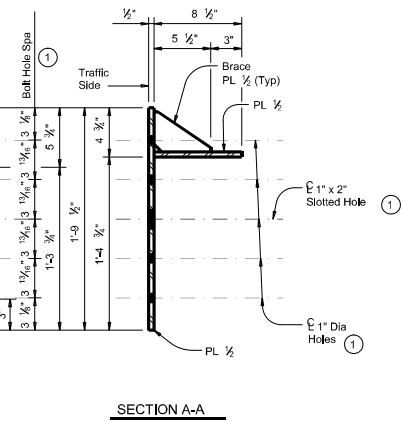

SECTION A-A

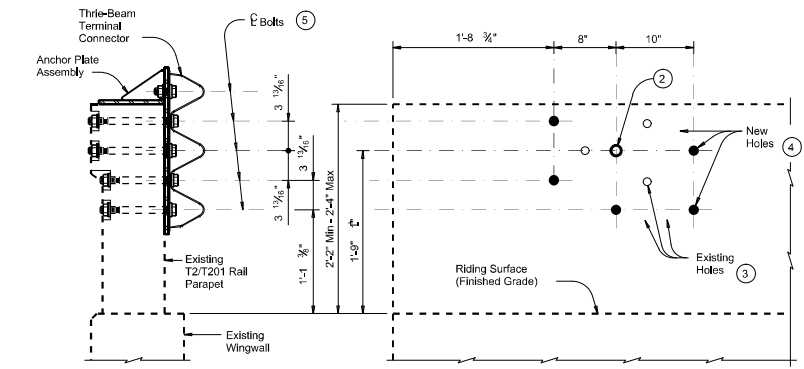

THRIE-BEAM TERMINAL CONNECTION DETAILS

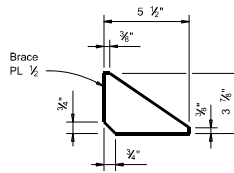

BRACE PLATE DETAIL

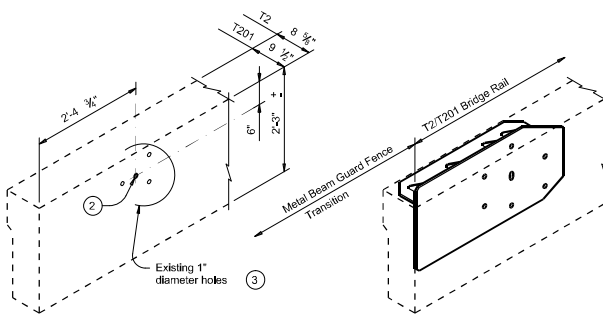

INSTALLATION DETAILS

This sheet is intended as a guide in preparing job-specific details to retrofit existing T2 or T201 rails with a Thrie-Beam terminal connector. This sheet may not be used without modification. The details shown may need to be amended if the exact existing conditions are not covered. In all cases, details and notes not required are to be removed or crossed out, "(MOD)" added, and the phrase "(Not to be used as a standard)" removed from the title block. This sheet must be signed, sealed, and dated by a registered Professional Engineer. The effective height of the existing rail (at the Anchor Plate location) above the finished riding surface, as seen by an errant vehicle, must be between 2'-2" and 2'-4". Alternate methods of retrofit must be used for effective heights beyond these limits. Dimensions of existing rail height (traffic side) should be shown. Particular care should be taken in identifying existing rail conditions and providing for proper Anchor Plate and MBGF transition positioning.

- 1 The Contractor must verify that locations of bolt holes match those in the Thrie-Beam Terminal Connector to be installed in that location, prior to fabrication of Anchor Plate assembly and prior to coring bolt holes in the existing T2/T201 parapet.
- 2 If the existing holes are aligned as expected, use the indicated existing 1" diameter hole in the installation of the Anchor Plate assembly and the Thrie-Beam Terminal Connector.
- 3 If the existing holes are not aligned as expected, holes that cannot be utilized in the installation and are within 3" of a new bolt hole must be filled with epoxy grout prior to coring new holes.
- 4 Drill new 1" diameter holes, each with a 2 1/2" diameter x 1" deep recess, through existing railing parapet. Note that recesses are only required when pedestrian sidewalks are adjacent to back of rail unless directed otherwise by the Engineer. Holes should be perpendicular to the roadside face of the parapet. Drill holes and recesses with coring type equipment. Percussion drilling is not allowed. Patch spalls, when directed by the Engineer, in accordance with Item 429, "Concrete Structure Repair", at the Contractor's expense.
- 5 7 ~ 7/8" diameter ASTM F3125 Gr A325 Hex Head Anchor Bolts each with 2 ~ 1 washers. Place washer under each head and nut. Provide bolts of sufficient length to extend a minimum of 1/2" beyond nut. Cut excess bolt length and paint cut surface with zinc-rich paint if directed by the Engineer.

3/4" O.D.

CONSTRUCTION NOTES:
 Field verify dimensions before commencing work and ordering materials.
 On T2 rail remove any MBGF (W-beam) and attachment hardware, from the face of rail if present, prior to installation of new MBGF Transition. Dispose of these materials as directed by the Engineer. Flushing of newly exposed existing bolt holes is not necessary except as stated here in or otherwise indicated on the plans. This work is considered subsidiary to the pertinent bid items.
 Attach the MBGF Transition to the existing parapet using the Anchor Plate assembly and the Thrie-Beam Terminal Connector. Splice the Thrie-Beam Terminal Connector and Thrie-Beam with the normal 12 connection bolts. Refer to Metal Beam Guard Fence Transition and Metal Beam Guard Fence detail sheets for additional details and information not shown herein.

MATERIAL NOTES:
 Fabricate Anchor Plate assembly with steel conforming to either ASTM A36 or A572 Gr 50. Anchor Plate assembly must be free of burrs, sharp edges and weld splatter. Grind edges and corners to a 1/8" flat or radius. Hot-dip galvanize Anchor Plate assembly in accordance with Item 445, "Galvanizing". Anchor bolts, nuts, and washers must conform to Item 449, "Anchor Bolts".

GENERAL NOTES:
 These details are for retrofitting existing rails only, not new construction, with a Thrie-Beam Terminal Connector. Shop drawings are not required for this installation. Payment for materials, fabrication, and installation of this assembly are to be included in unit price bid in accordance with Item 540 "MI Bm Gd Fen Trans (Anchor Plate)". Estimated weight of a single Anchor Plate assembly, including bolts, nuts, and washers, but not including the Thrie-Beam Terminal Connector = 190 Lbs.

		Bridge Division Standard	
T2/T201 TRANSITION RETROFIT GUIDE			
(NOT TO BE USED AS A STANDARD)			
T2/T201TR			
FILE: f18125419.dgn	DATE: TxDOT	CHK: TxDOT	DATE: TxDOT
SEPTEMBER 2019	001	001	US 96, ETC.
6442	70	001	US 96, ETC.
LFK	COUNTY	SABINE	SHEET NO. 53

Note: Bridge rail must be attached to a metal beam guard fence transition section (nested W-beam) which then attaches to a metal beam guard fence and extends along the embankment unless shown otherwise on the plans. See plan sheet for details and length for payment. A regular splice is used to join the approach guard fence transition to the bridge rail.

Note: Do not provide a tube splice in first section unless it crosses an expansion joint.

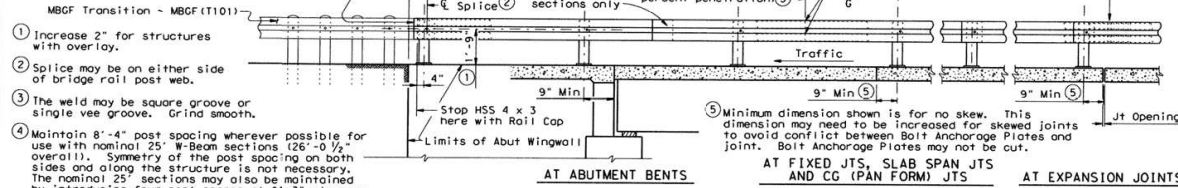

- Increase 2" for structures with overlay.
- Splice may be on either side of bridge rail post web.
- The weld may be square groove or single vee groove. Grind smooth.
- Maintain 8'-4" post spacing wherever possible for use with nominal 25" W-Beam sections (26'-0 1/2" overall). Symmetry of the post spacing on both sides and along the structure is not necessary. The nominal 25" sections may also be maintained by introducing four post spaces of 6'-3" or areas of conflict. Two adjacent spaces of 8'-8" and 8'-0" each are also permissible.

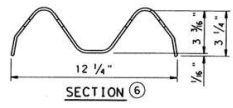

Members are 12 Gage Steel
Nom thickness = 0.1045" exclusive of protective coating. Actual section may vary slightly with the manufacturer and conforms to AASHTO M-180.

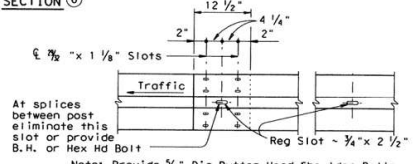

Note: Provide 3/4" Dia Button Head Shoulder Bolts or Hex Head Bolts (ASTM-A307) with Hex Nuts at all splice locations.

ROADWAY ELEVATION OF RAIL

TUBE & SLEEVE MEMBERS	
Rail Member	Sleeve Thickness
A 500 Grade C	0.188"
A 500 Grade B	0.250"
A 500 Grade A or A 501	0.313"

Note: Other sections of equal or greater strength are acceptable for sleeves.

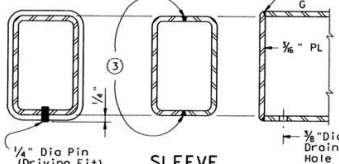
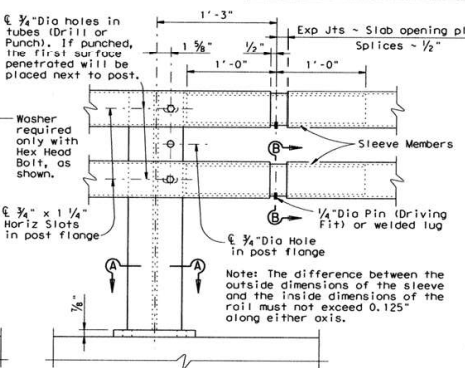
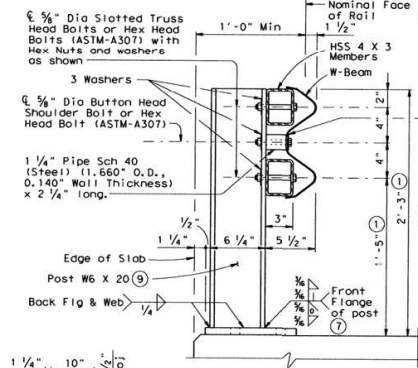

SLEEVE FABRICATION OPTION RAIL CAP

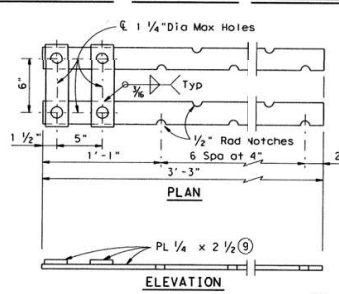
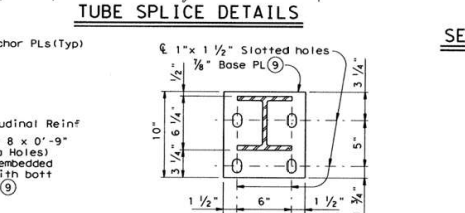
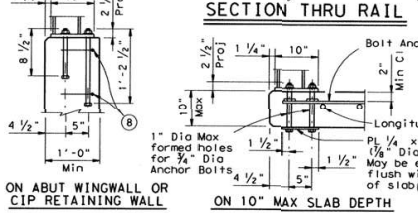

BOLT ANCHORAGE PLATES

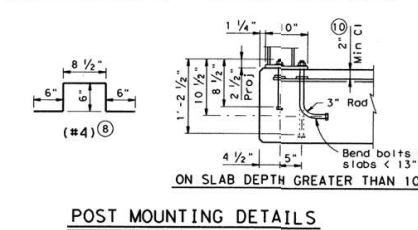

- In lieu of front Fig weld shown, a 3/8" fillet weld all around including edges of flange may be used.
- Adjust horizontal reinforcing as necessary and place two #4 bars around anchor bolts. These bars are to be considered subsidiary to Rail.
- All steel posts and plates are (ASTM-A36).
- Set plates under longitudinal reinforcing if necessary.
- Install one anchor plate assembly in slab at each rail post. Do not galvanize or oil this assembly. Bolt Anchorage Plates may not be cut.

POST MOUNTING DETAILS

CONSTRUCTION NOTES:
Attach section lengths of HSS 4 x 3 members continuously to a minimum of three posts (except at abutments with expansion joints).
Face of rail and posts must be vertical transversely unless otherwise approved by the Engineer. Posts must be perpendicular to adjacent roadway grade. Use epoxy mortar under post base plates if gaps larger than 1/8" exist.
At expansion slots in W-beam rail, tighten bolts snugly. For curved railing applications, fabricate the tubes and pipes when the radius is 600' or less and fabricate the W-beam to the radius when the radius is less than 150'. Submit shop drawings for approval when tubes are required to be fabricated to a radius.

MATERIAL NOTES:
Galvanize all steel components unless otherwise shown on plans.
Anchor bolts are 3/4" Dia ASTM-A325 bolts or A449 heavy hex bolts (or A449 threaded rods with one tack welded heavy hex nut each) with one heavy hex nut and one 2" O.D. washer (0.153" Min thickness plus one 1 1/2" O.D. hardened washer (0.122" Min thick) at each bolt. Optionally use rectangular 3/4" x 2 x 0'-3" ASTM-A36 plate with 3/4" Dia hole.

GENERAL NOTES:
This rail was evaluated based on the results of previous crash tests and approved for a NCHRP Report 350 TL-3 rating. The Metal Beam Guard Fence (T101) transition standard must be used regardless of the design speed.
This railing cannot be used on bridges with expansion joints providing more than 4" movement.
This rail requires a Min slab thickness of 8" and is not recommended for use with Box Beam or Double-Structures with asphalt overlay.
Rail anchorage details shown in this standard may require modification for select structure types. See appropriate details elsewhere in plans for these modifications.
This rail is not recommended for use with more than 3 posts mounted on any of the following structures: cast-in-place retaining walls, Traffic Railing Foundations (TRF), or bridge abutment wingwalls.
This standard, used in conjunction with the Rail Anchorage Curb (RAC) standard or the Rail Anchorage Curb Retrofit (RAC-R) standard, allows this rail to be mounted on box culverts.
For all rails, erection drawings showing section lengths, splice locations, rail post spacing and anchor bolt setting must be submitted to the Engineer for approval.
Average weight of railing with no overlay and with 0.25" tubes is 39 pfl.

Texas Department of Transportation
Bridge Division

TRAFFIC RAIL

TYPE T101

FILE: r1st003.dgn	DN: TxDOT	CR: TxDOT	DR: JTR	CS: JMR
©TxDOT April 2009	DISTRICT:	PROJECT NO.:	SHEET NO.	
REVISIONS:	LFK	RMC 6253-82-001	46	
	COUNTY:	CONTROL SECT. JOB	HIGHWAY	
	MACADDUCCHES	6253 82 001	91, ETC.	

"AS BUILT" TYPE T101

TEXAS DEPARTMENT OF TRANSPORTATION
©2023

FILE: RZ1	PROJECT NO.	SHEET NO.
6	6442-70-001	55
STATE	DIST.	COUNTY
TEXAS	LFK	SABINE
CONT.	SECT.	JOB
6442	70	001
HIGHWAY NO.	US 96, ETC.	

FOR INFORMATIONAL PURPOSES ONLY

4/12/2023 8:28:23 AM T:\L1600\Main\Contract\6442-70-001_Sub\Ine_MBGFC\DN\TypeT101ForInfoOnly.dgn

4/12/2023 8:28:28 AM T:\L\1000\Main\Contract\O&M - Route Maintenance\Contracts\FY23 Plans\6442-70-001 Subline MBGF\OGN\Types\T101RCForInfo\om1x.dgn

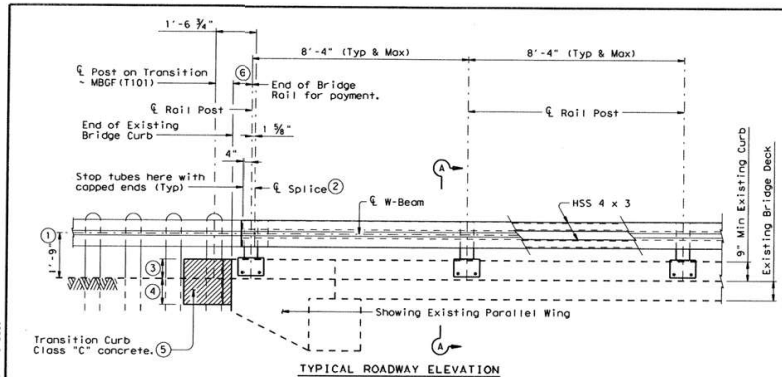

TYPICAL ROADWAY ELEVATION

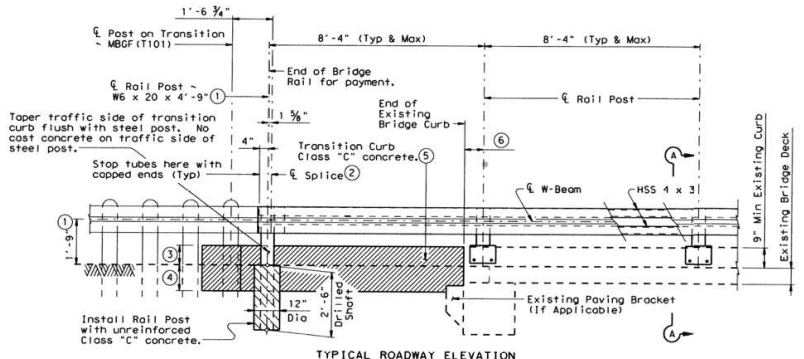

TYPICAL ROADWAY ELEVATION

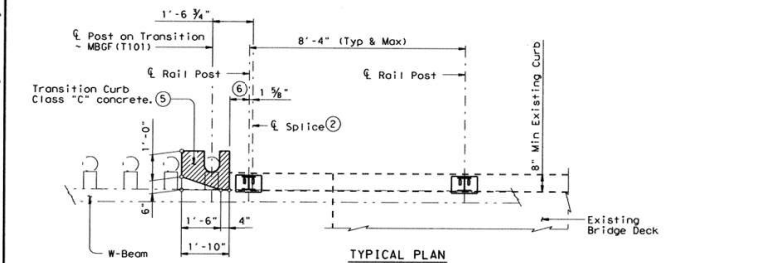

TYPICAL PLAN

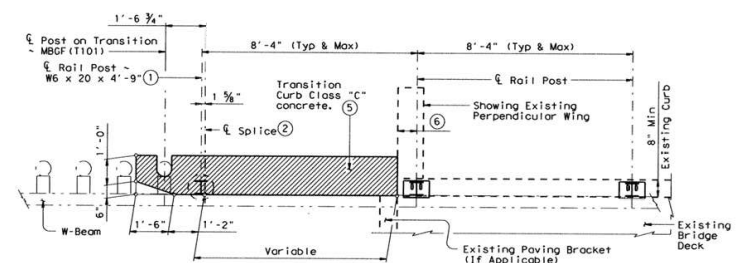

TYPICAL PLAN

EXAMPLE "A" RETROFIT WITH PARALLEL WING

(Showing 9" high and 8" wide curbs, higher and wider curbs similar)

EXAMPLE "B" RETROFIT WITH PERPENDICULAR WING⁷

(Showing 9" high and 8" wide curbs, higher and wider curbs similar)

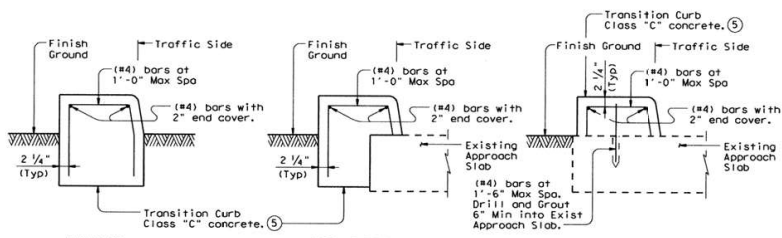

EXAMPLES OF TRANSITION CURB SECTIONS

(Reinforcement may be omitted for transition curbs less than 2 ft long).

- ① Increase by amount of existing overlay/seal coat thickness, not to exceed 2". If thickness of existing overlay/seal coat is greater than 2" at toe of rail, taper overlay at a 1:10 or flatter slope over the shoulder width to a thickness of 2" or less at toe of rail.
- ② Splice may be on either side of bridge rail post web.
- ③ Match existing bridge curb height.
- ④ Cast transition curb 1'-0" into soil or top of concrete approach slab.
- ⑤ Match existing bridge curb face on traffic side of transition curb. Transition curb 6" x 1'-6" taper will remain vertical.
- ⑥ Minimum distance from end of curb or open joint in curb to post centerline is existing curb height without overlay/seal coats, but not less than 9".
- ⑦ Details similar to Example "A" may be used if no existing structure components (like Paving Brackets) interfere with or prevent locating first transition post at 1'-6 3/4" adjacent to first rail post splice on existing structure.



SHEET 1 OF 3

Texas Department of Transportation
Bridge Division

RETROFIT GUIDE FOR T101 RAIL ON CURBS

TYPE T101RC (MOD)

FILE: r1st0203.dgn	DN: T1001	CR: T1001	DN: JTR	CR: JMB
© T1001 April 2009	DISTRICT	PROJECT NO.	SHEET	
REVISIONS	LFK	RMC 6253-82-001	47	
	COUNTY	CONTROL SECT	JOB	HIGHWAY NO.
	MOOREHEADS	62531 821001	911	ETC

SHEET 1 OF 3

"AS BUILT"
TYPE T101RC
(MOD)

TEXAS DEPARTMENT OF TRANSPORTATION ©2023				
REP. NO.	PROJECT NO.			SHEET NO.
6	6442-70-001			56
STATE	DIST.	COUNTY		
TEXAS	LFK	SABINE		
CONT.	SECT.	JOB	HIGHWAY NO.	
6442	70	001	US 96, ETC	

FOR INFORMATIONAL PURPOSES ONLY

4/12/2023 8:28:31 AM T:\L\KDDM\Drawn - Contracts\Q&BMC - Routine Maintenance Contracts\FY23 Plans\6442-70-001 Sabine MBGF.VOCN\Types\T101RCForInfoOnly.dgn

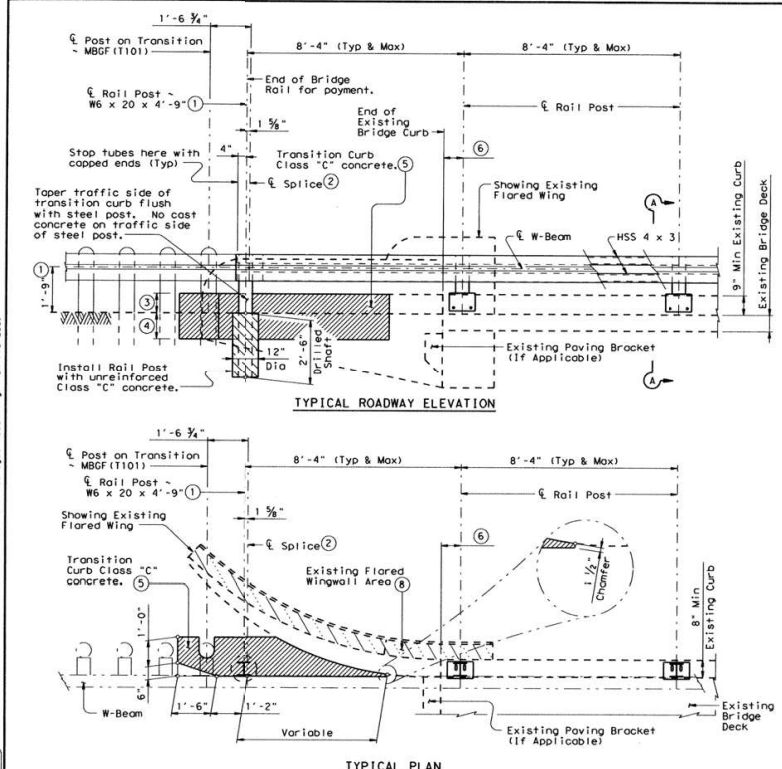

EXAMPLE "C" RETROFIT WITH FLARED WING
(Showing 9" high and 8" wide curbs, higher and wider curbs similar)

- ① Increase by amount of existing overlay/seal coat thickness, not to exceed 2". If thickness of existing overlay/seal coat is greater than 2" at toe of rail, taper overlay at a 1:10 or flatter slope over the shoulder width to a thickness of 2" or less at toe of rail.
- ② Splice may be on either side of bridge rail post web.
- ③ Match existing bridge curb height.
- ④ Cast transition curb 1'-0" into soil.
- ⑤ Match existing bridge curb face on traffic side of transition curb. Transition curb 6" x 1'-6" taper will remain vertical.
- ⑥ Minimum distance from end of curb or open joint in curb to post centerline is existing curb height without overlay/seal coats, but not less than 9".
- ⑦ Remove all existing structure area from top of existing curb. Cut and grind all existing reinforcing extending from top of existing curb flush and point ends with two coats of zinc-rich paint conforming to the Item "Galvanizing".

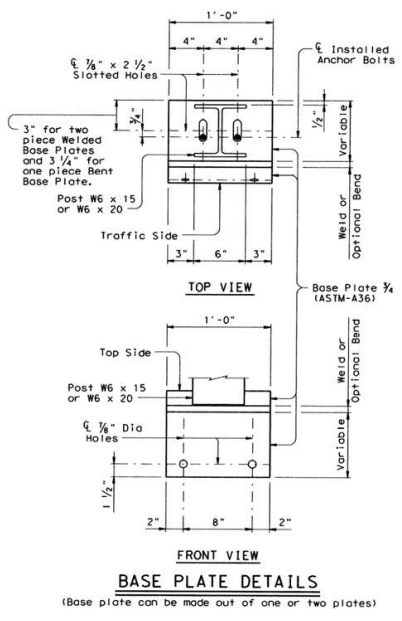

Notes: Bridge rail must be attached to the MBGF (T101) transition which then attaches to a metal beam guard fence and extends along the embankment. The splice joining the approach guard fence transition to the bridge rail requires 1'-6 3/4" post spacing. Do not provide a tube splice in first section unless it crosses an expansion armor joint. Maintain 8'-4" post spacing wherever possible for use with nominal 25" W-Beam sections (26'-0 1/2" overall). Symmetry of the post spacing on both sides and along the structure is not necessary. The nominal 25" sections may also be maintained by introducing four post spaces of 6'-3" at areas of conflict. Two adjacent spaces of 8'-8" and 8'-0" each are also permissible.

CONSTRUCTION NOTES:
Panel lengths of tube members must be attached continuously to a minimum of three posts (except at abutments with expansion joints).
Rail Posts must be set perpendicular to adjacent roadway grade. Use epoxy mortar under post base plates if gaps larger than 1/8" exist.
All expansion slots in W-Beam rail, tighten bolts snugly.

MATERIAL NOTES:
All steel components except reinforcing must be galvanized unless otherwise shown in plans.

GENERAL NOTES:
A similar full-height railing (T101) has been evaluated to meet NCHRP Report 350 Test Level 3 (TL-3) criteria. This retrofit railing has been structurally evaluated to have strength equal to or exceeding that of the tested railing. See Traffic Rail Type T101 standard for details and notes not shown herein. Using this sheet with the T101 standard, note that anchor bolts, bolt anchor plates, post base plate and post lengths are not used as shown on the T101 standard. This sheet replaces or omits some items on the T101 standard.
All bolts, nuts, washers, adhesive anchors, reinforcement, and transition curb concrete are considered as parts of the rail for payment.
Erection drawings showing panel lengths, splice locations, post spacing, anchor bolt locations and adhesive anchor test data to demonstrate pullout strength must be submitted to the Engineer for approval. Shop drawings will not be required.
Avg weight with no overlay increase and with 0.25" tubest 23 pif (9", 11" & 12" Curbs)
23 pif (18" Curbs)



David B. Collum, P.E.
4-11-13

SHEET 2 OF 3

Texas Department of Transportation
Bridge Division

RETROFIT GUIDE FOR T101 RAIL ON CURBS

TYPE T101RC (MOD)

FILES: F1510023.dgn	DN: TXDOT	CR: TXDOT	DN: JTR	CR: JMH
TXDOT: Apr 11 2009	DISTRICT:	PROJECT NO.:	SHEET	
REVISIONS:	LFK	RMC 6253-82-001	48	
	NO. OF CHANGES:	6253 82 001	91, 92, 93, 94	

SHEET 2 OF 3

"AS BUILT"
TYPE T101RC
(MOD)

TEXAS DEPARTMENT OF TRANSPORTATION				
©2023				
FILED NO.	PROJECT NO.		SHEET NO.	
6	6442-70-001		57	
STATE	DIST.	COUNTY		
TEXAS	LFK	SABINE		
CONT.	SECT.	JOB	HIGHWAY NO.	
6442	70	001	US 96, ETC	

FOR INFORMATIONAL PURPOSES ONLY

4/12/2023 8:28:35 AM
 T:\L1600A\Maint. Contracts\Q&RMC - Routine Maintenance Contracts\FY23 Plans\6442-70-001 Sabine MBGF\DCN\Types\T101RCForInfo\onl\y.dgn

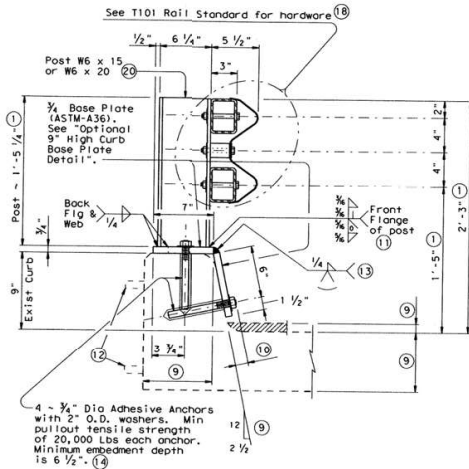

SECTION A-A OF 9" HIGH CURBS
 (Showing example of 8" Min width curb, wider curbs similar)

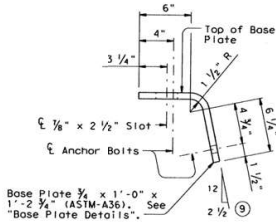

OPTIONAL 9" HIGH CURB BASE PLATE DETAIL
 (Bend one piece base plate)

- ① Increase by amount of existing overlay/seal coat thickness, not to exceed 2". If thickness of existing overlay/seal coat is greater than 2" at toe of rail, taper overlay at a 1:10 or flatter slope over the shoulder width to a thickness of 2" or less at toe of rail.
- ② See elsewhere in plans for dimensions (curb width and height, slab and overlay thickness). Slope of curb may differ from what is shown. Adjust base plate as necessary to conform to curb face geometry.
- ③ 1 1/2" Bolt Projection (Typ).
- ④ In lieu of front flange weld shown, a 3/8" fillet weld all around including edges of flange may be used.
- ⑤ Remove existing railing (including posts), cut and grind anchor bolts flush and point ends with two coats of zinc-rich paint conforming to the item "Galvanizing".
- ⑥ Complete joint penetration weld. Optional one piece base plate may be used. See "Optional 9" High Curb Base Plate Detail".

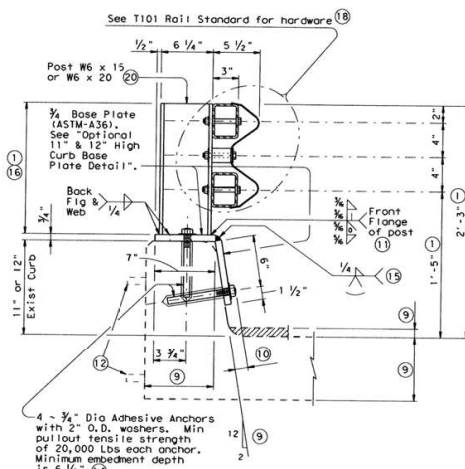

SECTION A-A OF 11" & 12" HIGH CURBS
 (Showing example of 8" Min width curb, wider curbs similar)

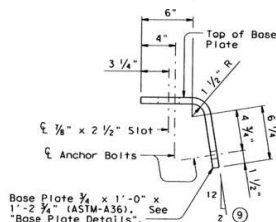

OPTIONAL 11" & 12" HIGH CURB BASE PLATE DETAIL
 (Bend one piece base plate)

- ⑦ Hole size, hole cleaning and other installation requirements must conform to manufacturer's instructions. Use a Type III Class C epoxy.
- ⑧ Complete joint penetration weld. Optional one piece base plate may be used. See "Optional 11" & 12" High Curb Base Plate Detail".
- ⑨ On 11" Curbs, Posts are 1'-3 1/4". On 12" Curbs, Posts are 1'-2 1/4".
- ⑩ Complete joint penetration weld. Optional one piece base plate may be used. See "Optional 18" High Curb Base Plate Detail".
- ⑪ See T101 standard for details and notes not shown.
- ⑫ This retrofit condition will only accommodate one top HSS 4 x 3 member under W-Beam.
- ⑬ See T101 standard for post spacing, unless shown otherwise.

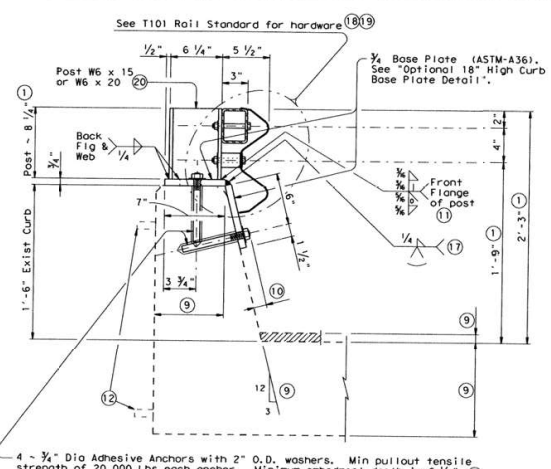

SECTION A-A OF 18" HIGH CURBS
 (Showing example of 8" Min width curb, wider curbs similar)

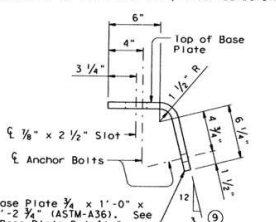

OPTIONAL 18" HIGH CURB BASE PLATE DETAIL
 (Bend one piece base plate)



David R. Collmorgen
 4-11-13

SHEET 3 OF 3

Texas Department of Transportation
 Bridge Division

**RETROFIT GUIDE FOR
 T101 RAIL ON CURBS**

TYPE T101RC (MOD)

FILE#	171810023.dgn	DATE TADOT	04/11/2009	DATE JTR		DATE JRM	
REVISED	1x001	ADP	11/2009	DISTRICT	RMC	PROJECT NO.	6253-82-001
		COUNTY	LFK	CONTROL SECT	49	JOB	49
		CONTRACT	6253-82-001	SECTION	1	HIGHWAY	97, ETC.

SHEET 3 OF 3

**"AS BUILT"
 TYPE T101RC
 (MOD)**

TEXAS DEPARTMENT OF TRANSPORTATION ©2023							
FILE#	6253-82-001	PROJECT NO.	6442-70-001	SHEET NO.	58		
STATE	TX	DIST.	LFK	COUNTY	SABINE		
CONTRACT	6442	SECTION	70	JOB	001	HIGHWAY NO.	US 96, ETC.

FOR INFORMATIONAL PURPOSES ONLY

DISCUSSION: The use of this standard is governed by the "Texas Engineering Practice Act". No warranty of any kind is made by TxDOT for any purpose whatsoever. TxDOT assumes no responsibility for the conversion of this standard into a contract. The user of this standard is responsible for the appropriate application of this standard to the project.

DATE: 5/15/2023 7:53:09 AM
 FILE: T:\LKFD\MAINT\Contracts\0-RMC - Routine Maintenance Contracts\0-RMC - Routine Maintenance Contracts.dwg

I. STORMWATER POLLUTION PREVENTION-CLEAN WATER ACT SECTION 402

TPDES TXR 150000: Stormwater Discharge Permit or Construction General Permit required for projects with 1 or more acres disturbed soil. Projects with any disturbed soil must protect for erosion and sedimentation in accordance with Item 506.

List MS4 Operator(s) that may receive discharges from this project. They may need to be notified prior to construction activities.

No Action Required Required Action

1. The proposed work of this project is to repair damaged guard fence, attenuator, and metal rail within the Sabine County Maintenance Section on State right-of-way that may affect the safety of the traveling public. This activity maintains the original line and grade, hydraulic capacity and original purpose of the site. Therefore, this project meets the definition of a routine maintenance activity as defined in the TPDES General Permit No. TXR150000 issued March 5, 2023 and TCEQ's TPDES CGP does not apply.

II. WORK IN OR NEAR STREAMS, WATERBODIES AND WETLANDS CLEAN WATER ACT SECTIONS 401 AND 404

USACE Permit required for filling, dredging, excavating or other work in any water bodies, rivers, creeks, streams, wetlands or wet areas.

The Contractor must adhere to all of the terms and conditions associated with the following permit(s):

No Permit Required
 Nationwide Permit 14 - PCN not Required (less than 1/10th acre waters or wetlands affected)
 Nationwide Permit 14 - PCN Required (1/10 to <1/2 acre, 1/3 in tidal waters)
 Individual 404 Permit Required
 Other Nationwide Permit Required: NWP#

Required Actions: List waters of the US permit applies to, location in project and check Best Management Practices planned to control erosion, sedimentation and post-project TSS.

The elevation of the ordinary high water marks of any areas requiring work to be performed in the waters of the US requiring the use of a nationwide permit can be found on the Bridge Layouts.

Best Management Practices:

Erosion	Sedimentation	Post-Construction TSS
<input type="checkbox"/> Temporary Vegetation	<input type="checkbox"/> Silt Fence	<input type="checkbox"/> Vegetative Filter Strips
<input type="checkbox"/> Blankets/Matting	<input type="checkbox"/> Rock Berm	<input type="checkbox"/> Retention/Irrigation Systems
<input type="checkbox"/> Mulch	<input type="checkbox"/> Triangular Filter Dike	<input type="checkbox"/> Extended Detention Basin
<input type="checkbox"/> Sodding	<input type="checkbox"/> Sand Bag Berm	<input type="checkbox"/> Constructed Wetlands
<input type="checkbox"/> Interceptor Swale	<input type="checkbox"/> Straw Bale Dike	<input type="checkbox"/> Wet Basin
<input type="checkbox"/> Diversion Dike	<input type="checkbox"/> Brush Berms	<input type="checkbox"/> Erosion Control Compost
<input type="checkbox"/> Erosion Control Compost	<input type="checkbox"/> Erosion Control Compost	<input type="checkbox"/> Mulch Filter Berm and Socks
<input type="checkbox"/> Mulch Filter Berm and Socks	<input type="checkbox"/> Mulch Filter Berm and Socks	<input type="checkbox"/> Compost Filter Berm and Socks
<input type="checkbox"/> Compost Filter Berm and Socks	<input type="checkbox"/> Compost Filter Berm and Socks	<input type="checkbox"/> Vegetation Lined Ditches
	<input type="checkbox"/> Stone Outlet Sediment Traps	<input type="checkbox"/> Sand Filter Systems
	<input type="checkbox"/> Sediment Basins	<input type="checkbox"/> Grassy Swales

III. CULTURAL RESOURCES

Refer to TxDOT Standard Specifications in the event historical issues or archeological artifacts are found during construction. Upon discovery of archeological artifacts (bones, burnt rock, flint, pottery, etc.) cease work in the immediate area and contact the Engineer immediately.

No Action Required Required Action

1. Contractor to repair or replace in kind, at their own expense, any historic materials damaged (buildings, historical markers, etc.) in the course of executing the work. Contractor is responsible for locating replacement source for historical materials damaged in the course of the work. TxDOT-Environmental Affairs Division is to be informed of the proposed repairs to facilitate consultation with Texas Historical Commission prior to the execution of repairs.

IV. VEGETATION RESOURCES

Preserve native vegetation to the extent practical. Contractor must adhere to Construction Specification Requirements Specs 162, 164, 192, 193, 506, 730, 751, 752 in order to comply with requirements for invasive species, beneficial landscaping, and tree/brush removal commitments.

No Action Required Required Action

Action No.

1. N/A

V. FEDERAL LISTED, PROPOSED THREATENED, ENDANGERED SPECIES, CRITICAL HABITAT, STATE LISTED SPECIES, CANDIDATE SPECIES AND MIGRATORY BIRDS.

If any of the listed species are observed, cease work in the immediate area, do not disturb species or habitat and contact the Engineer immediately.

No Action Required Required Action

1. Red-cockaded Woodpecker (federally listed endangered species) habitat is present adjacent to the ROW along SH 87, FM 2426, and FM 2343. Conservation measures have been agreed upon by the United States Fish and Wildlife Service and TxDOT to ensure that the proposed action will not adversely affect the red-cockaded woodpecker. The conservation measures below must be followed in order to be in compliance with the Endangered Species Act.

- A. NO WORK shall be performed at the below roadway limits from April 1 to July 31.
- B. Work shall begin one hour after sunrise and cease one hour before sunset.
- C. NO STOCKPILES or EQUIPMENT STORAGE shall be allowed along the below roadway limits.

- On SH 87 from 0.75 miles South of FM 3315 to the Newton County Line
- On FM 2426 from 2.8 miles East of FM 1 to 8.1 miles east of FM 1
- On FM 2343 from 1.5 miles South of SH 87 to 2.15 miles south of SH 87

2. Texas golden gladdereed (federally listed endangered species) critical habitat is present within the ROW along SH 21. The conservation measure below must be followed in order to be in compliance with the Endangered Species Act:

- A. NO STOCKPILES or EQUIPMENT STORAGE shall be allowed within the ROW along SH 21 at the below roadway limits.
- B. NO EQUIPMENT or VEHICLES shall leave the pavement within the below roadway limits.

- SH 21 from 0.57 miles East of FM 330 to 1.63 miles East of FM 330.

LIST OF ABBREVIATIONS

BMP: Best Management Practice	SPCC: Spill Prevention Control and Countermeasure
CGP: Construction General Permit	SWP3: Storm Water Pollution Prevention Plan
DSHS: Texas Department of State Health Services	PCN: Pre-Construction Notification
FHWA: Federal Highway Administration	PSL: Project Specific Location
MOA: Memorandum of Agreement	TCEQ: Texas Commission on Environmental Quality
MOU: Memorandum of Understanding	TPDES: Texas Pollutant Discharge Elimination System
MS4: Municipal Separate Stormwater Sewer System	TPWD: Texas Parks and Wildlife Department
MBTA: Migratory Bird Treaty Act	TxDOT: Texas Department of Transportation
NOT: Notice of Termination	T&E: Threatened and Endangered Species
NWP: Nationwide Permit	USACE: U.S. Army Corps of Engineers
NOI: Notice of Intent	USFWS: U.S. Fish and Wildlife Service

VI. HAZARDOUS MATERIALS OR CONTAMINATION ISSUES

General (applies to all projects):
 Comply with the Hazard Communication Act (the Act) for personnel who will be working with hazardous materials by conducting safety meetings prior to beginning construction and making workers aware of potential hazards in the workplace. Ensure that all workers are provided with personal protective equipment appropriate for any hazardous materials used. Obtain and keep on-site Material Safety Data Sheets (MSDS) for all hazardous products used on the project, which may include, but are not limited to the following categories: Paints, acids, solvents, asphalt products, chemical additives, fuels and concrete curing compounds or additives. Provide protected storage, off bare ground and covered, for products which may be hazardous. Maintain product labelling as required by the Act. Maintain an adequate supply of on-site spill response materials, as indicated in the MSDS. In the event of a spill, take actions to mitigate the spill as indicated in the MSDS, in accordance with safe work practices, and contact the District Spill Coordinator immediately. The Contractor shall be responsible for the proper containment and cleanup of all product spills.

Contact the Engineer if any of the following are detected:
 * Dead or distressed vegetation (not identified as normal)
 * Trash piles, drums, canister, barrels, etc.
 * Undesirable smells or odors
 * Evidence of leaching or seepage of substances

Does the project involve any bridge class structure rehabilitation or replacements (bridge class structures not including box culverts)?
 Yes No

If "No", then no further action is required.
 If "Yes", then TxDOT is responsible for completing asbestos assessment/inspection.

Are the results of the asbestos inspection positive (is asbestos present)?
 Yes No

If "Yes", then TxDOT must retain a DSHS licensed asbestos consultant to assist with the notification, develop abatement/mitigation procedures, and perform management activities as necessary. The notification form to DSHS must be postmarked at least 15 working days prior to scheduled demolition.

If "No", then TxDOT is still required to notify DSHS 15 working days prior to any scheduled demolition.

In either case, the Contractor is responsible for providing the date(s) for abatement activities and/or demolition with careful coordination between the Engineer and asbestos consultant in order to minimize construction delays and subsequent claims.

Any other evidence indicating possible hazardous materials or contamination discovered on site. Hazardous Materials or Contamination Issues Specific to this Project:

No Action Required Required Action

Action No.

1. N/A

VII. OTHER ENVIRONMENTAL ISSUES

Portions of State Highway (SH) 21, SH 87, Farm-to-Market (FM) 330, FM 242, FM 3121, FM 83, FM 3382, FM 3520, FM 1368, FM 944, FM 2971, FM 2426, FM 2928, FM 2343, and FM 201 in Sabine County pass through compartments of the Sabine National Forest. The following actions are required.

No Action Required Required Action

Action No.

1. Maintenance Supervisor shall notify Sabine National Forest (USFS) prior to commencing work on the above listed roadways within USFS boundaries.

2. NO stockpiling or storage of materials and equipment within USFS boundaries.

Texas Department of Transportation		Design Division Standard	
EPIC			
(ENVIRONMENTAL PERMITS, ISSUES AND COMMITMENTS)			
FILE: epic.dgn	DN: TxDOT	CR: RG	DN: VP
CR: AR	CR: AR	CR: AR	CR: AR
© TxDOT: February 2015	CONT SECT	JOB	HIGHWAY
12-12-2011 (05)	6442	70	001
00-07-14 ADDD NOTE SECTION IV.	DIST	COUNTY	SHEET NO.
01-22-2010 SECTION I (OWNER ITEM 1122 TO ITEM 506, ADDD GRASSY SWALES.	LFK	SABINE	59

Certificate Of Completion

Envelope Id: 643A76D6EB874005A299111667C815B2
Subject: Complete with DocuSign: 6442-70-001 Sabine MBGF.pdf
Source Envelope:
Document Pages: 62
Certificate Pages: 5
AutoNav: Enabled
EnvelopeId Stamping: Enabled
Time Zone: (UTC-06:00) Central Time (US & Canada)

Status: Completed

Envelope Originator:
Spencer Branske
125 E. 11th Street
Austin, TX 78701
Spencer.Branske@txdot.gov
IP Address: 204.64.21.247

Record Tracking

Status: Original	5/17/2023 7:16:41 AM	Holder: Spencer Branske Spencer.Branske@txdot.gov	Location: DocuSign
Security Appliance Status: Connected		Pool: Statelocal	
Storage Appliance Status: Connected		Pool: Texas Department of Transportation	Location: DocuSign

Signer Events

Jeremy King				
Jeremy.King@txdot.gov				Sent: 5/17/2023 7:19:49 AM Viewed: 5/17/2023 9:35:35 AM
Lufkin District Maintenance Engineer				Signed: 5/17/2023 9:40:10 AM
Texas Department of Transportation				
Security Level: Email, Account Authentication (Optional)				Signature Adoption: Uploaded Signature Image Using IP Address: 204.64.21.247



Electronic Record and Signature Disclosure: Not Offered via DocuSign

Kevin Buranakittipinyo, Dir of Construction				Sent: 5/17/2023 9:40:21 AM
Kevin.Buranakittipinyo@txdot.gov				Viewed: 5/17/2023 9:41:12 AM
Director of Operations				Signed: 5/17/2023 9:41:19 AM
TXDOT - Lufkin				
Security Level: Email, Account Authentication (Optional)				Signature Adoption: Uploaded Signature Image Using IP Address: 204.64.21.246



Electronic Record and Signature Disclosure:

Accepted: 7/25/2016 9:02:34 AM
ID: 1b3075d3-b3ec-4024-b93e-27b9431cb5e3

In Person Signer Events

Signature	Timestamp
-----------	-----------

Editor Delivery Events

Status	Timestamp
--------	-----------

Agent Delivery Events

Status	Timestamp
--------	-----------

Intermediary Delivery Events

Status	Timestamp
--------	-----------

Certified Delivery Events

Status	Timestamp
--------	-----------

Carbon Copy Events

Status	Timestamp
--------	-----------

Tamara Gibson

Sent: 5/17/2023 9:41:28 AM

Tamara.Gibson@txdot.gov

Viewed: 5/17/2023 9:42:20 AM

Texas Department of Transportation
Security Level: Email, Account Authentication (Optional)



Electronic Record and Signature Disclosure:
Not Offered via DocuSign

Witness Events	Signature	Timestamp
----------------	-----------	-----------

Notary Events	Signature	Timestamp
---------------	-----------	-----------

Envelope Summary Events	Status	Timestamps
-------------------------	--------	------------

Envelope Sent	Hashed/Encrypted	5/17/2023 7:19:49 AM
---------------	------------------	----------------------

Certified Delivered	Security Checked	5/17/2023 9:41:12 AM
---------------------	------------------	----------------------

Signing Complete	Security Checked	5/17/2023 9:41:19 AM
------------------	------------------	----------------------

Completed	Security Checked	5/17/2023 9:41:28 AM
-----------	------------------	----------------------

Payment Events	Status	Timestamps
----------------	--------	------------

Electronic Record and Signature Disclosure		
--	--	--

ELECTRONIC RECORD AND SIGNATURE DISCLOSURE

From time to time, Texas Department of Transportation (we, us or Company) may be required by law to provide to you certain written notices or disclosures. Described below are the terms and conditions for providing to you such notices and disclosures electronically through your DocuSign, Inc. (DocuSign) Express user account. Please read the information below carefully and thoroughly, and if you can access this information electronically to your satisfaction and agree to these terms and conditions, please confirm your agreement by clicking the 'I agree' button at the bottom of this document.

Getting paper copies

At any time, you may request from us a paper copy of any record provided or made available electronically to you by us. For such copies, as long as you are an authorized user of the DocuSign system you will have the ability to download and print any documents we send to you through your DocuSign user account for a limited period of time (usually 30 days) after such documents are first sent to you. After such time, if you wish for us to send you paper copies of any such documents from our office to you, you will be charged a \$0.00 per-page fee. You may request delivery of such paper copies from us by following the procedure described below.

Withdrawing your consent

If you decide to receive notices and disclosures from us electronically, you may at any time change your mind and tell us that thereafter you want to receive required notices and disclosures only in paper format. How you must inform us of your decision to receive future notices and disclosure in paper format and withdraw your consent to receive notices and disclosures electronically is described below.

Consequences of changing your mind

If you elect to receive required notices and disclosures only in paper format, it will slow the speed at which we can complete certain steps in transactions with you and delivering services to you because we will need first to send the required notices or disclosures to you in paper format, and then wait until we receive back from you your acknowledgment of your receipt of such paper notices or disclosures. To indicate to us that you are changing your mind, you must withdraw your consent using the DocuSign 'Withdraw Consent' form on the signing page of your DocuSign account. This will indicate to us that you have withdrawn your consent to receive required notices and disclosures electronically from us and you will no longer be able to use your DocuSign Express user account to receive required notices and consents electronically from us or to sign electronically documents from us.

All notices and disclosures will be sent to you electronically

Unless you tell us otherwise in accordance with the procedures described herein, we will provide electronically to you through your DocuSign user account all required notices, disclosures, authorizations, acknowledgements, and other documents that are required to be provided or made available to you during the course of our relationship with you. To reduce the chance of you inadvertently not receiving any notice or disclosure, we prefer to provide all of the required notices and disclosures to you by the same method and to the same address that you have given us. Thus, you can receive all the disclosures and notices electronically or in paper format through the paper mail delivery system. If you do not agree with this process, please let us know as described below. Please also see the paragraph immediately above that describes the consequences of your electing not to receive delivery of the notices and disclosures electronically from us.

How to contact Texas Department of Transportation:

You may contact us to let us know of your changes as to how we may contact you electronically, to request paper copies of certain information from us, and to withdraw your prior consent to receive notices and disclosures electronically as follows:

To contact us by email send messages to: kevin.setoda@txdot.gov

To advise Texas Department of Transportation of your new e-mail address

To let us know of a change in your e-mail address where we should send notices and disclosures electronically to you, you must send an email message to us at kevin.setoda@txdot.gov and in the body of such request you must state: your previous e-mail address, your new e-mail address. We do not require any other information from you to change your email address..

In addition, you must notify DocuSign, Inc to arrange for your new email address to be reflected in your DocuSign account by following the process for changing e-mail in DocuSign.

To request paper copies from Texas Department of Transportation

To request delivery from us of paper copies of the notices and disclosures previously provided by us to you electronically, you must send us an e-mail to kevin.setoda@txdot.gov and in the body of such request you must state your e-mail address, full name, US Postal address, and telephone number. We will bill you for any fees at that time, if any.

To withdraw your consent with Texas Department of Transportation

To inform us that you no longer want to receive future notices and disclosures in electronic format you may:

- i. decline to sign a document from within your DocuSign account, and on the subsequent page, select the check-box indicating you wish to withdraw your consent, or you may;
- ii. send us an e-mail to kevin.setoda@txdot.gov and in the body of such request you must state your e-mail, full name, IS Postal Address, telephone number, and account number. We do not need any other information from you to withdraw consent.. The consequences of your withdrawing consent for online documents will be that transactions may take a longer time to process..

Required hardware and software

Operating Systems:	Windows2000? or WindowsXP?
Browsers (for SENDERS):	Internet Explorer 6.0? or above
Browsers (for SIGNERS):	Internet Explorer 6.0?, Mozilla FireFox 1.0, NetScape 7.2 (or above)
Email:	Access to a valid email account
Screen Resolution:	800 x 600 minimum
Enabled Security Settings:	<ul style="list-style-type: none">• Allow per session cookies

- Users accessing the internet behind a Proxy Server must enable HTTP 1.1 settings via proxy connection

** These minimum requirements are subject to change. If these requirements change, we will provide you with an email message at the email address we have on file for you at that time providing you with the revised hardware and software requirements, at which time you will have the right to withdraw your consent.

Acknowledging your access and consent to receive materials electronically

To confirm to us that you can access this information electronically, which will be similar to other electronic notices and disclosures that we will provide to you, please verify that you were able to read this electronic disclosure and that you also were able to print on paper or electronically save this page for your future reference and access or that you were able to e-mail this disclosure and consent to an address where you will be able to print on paper or save it for your future reference and access. Further, if you consent to receiving notices and disclosures exclusively in electronic format on the terms and conditions described above, please let us know by clicking the 'I agree' button below.

By checking the 'I Agree' box, I confirm that:

- I can access and read this Electronic CONSENT TO ELECTRONIC RECEIPT OF ELECTRONIC RECORD AND SIGNATURE DISCLOSURES document; and
- I can print on paper the disclosure or save or send the disclosure to a place where I can print it, for future reference and access; and
- Until or unless I notify Texas Department of Transportation as described above, I consent to receive from exclusively through electronic means all notices, disclosures, authorizations, acknowledgements, and other documents that are required to be provided or made available to me by Texas Department of Transportation during the course of my relationship with you.