

SEE SHEET 2 FOR INDEX OF SHEETS

STATE OF TEXAS
DEPARTMENT OF TRANSPORTATION

FHWA TEXAS DIVISION	RMC 6417-38-001	PROJECT NO.	1
STATE	DISTRICT	COUNTY	
TEXAS	LFK	San Augustine	
CONTROL	SECTION	JOB	HIGHWAY NO.
6417	38	001	US 96, etc.

PLANS OF PROPOSED
STATE HIGHWAY ROUTINE MAINTENANCE CONTRACT
TYPE OF WORK:

REPAIR/UPGRADE AND MAINTENANCE OF METAL BEAM GUARD FENCE

RMC 6417-38-001

US 96, ETC.

SAN AUGUSTINE COUNTY

LIMITS: VARIOUS LOCATIONS WITHIN THE SAN AUGUSTINE COUNTY MAINTENANCE SECTION

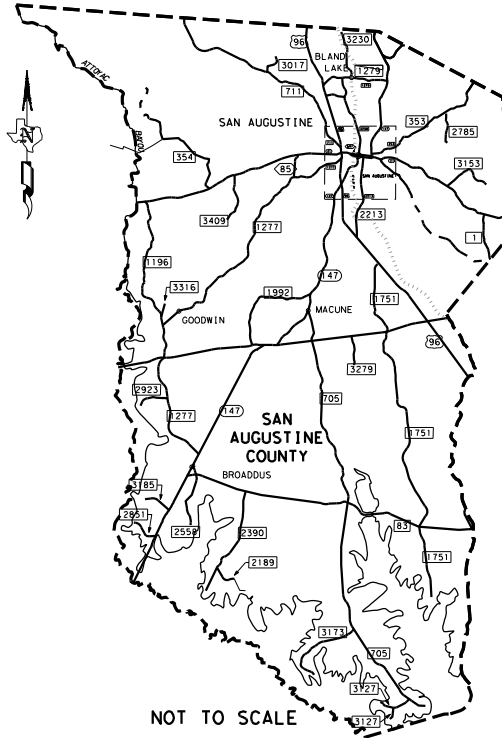

NOT TO SCALE

BARRICADES AND WARNING SIGNS
PROJECT LIMIT BARRICADES WILL NOT BE REQUIRED. THE CONTRACTOR SHALL PROVIDE AND ERECT WARNING SIGNS IN ACCORDANCE WITH THE BARRICADE & CONSTRUCTION STANDARDS, TCP STANDARDS, THE "TEXAS MANUAL ON UNIFORM TRAFFIC CONTROL DEVICES" AND AS DIRECTED.



RECOMMENDED BY: LETTING:
Jeremy King, P.E. 12/6/2022
DISTRICT MAINTENANCE ENGINEER DATE
5135292FE4184A4...
APPROVED BY: LETTING:
[Signature] 12/6/2022
DIRECTOR OF OPERATIONS DATE

SPECIFICATIONS ADOPTED BY THE TEXAS DEPARTMENT OF TRANSPORTATION NOVEMBER 1, 2014 AND SPECIAL SPECIFICATION ITEMS INCLUDED IN THE CONTRACT SHALL GOVERN ON THIS PROJECT.

© 2023 BY TEXAS DEPARTMENT OF TRANSPORTATION. ALL RIGHTS RESERVED.

11/17/2022 12:49:21 PM T:\LFDOM\Main\Contract\6417-38-001 - Routine Maintenance Contracts\FY23 Plans\6417-38-001 - San Augustine\MBGF\Drawings\MBGF_San Augustine.dgn

INDEX OF SHEETS

<u>SHEET NO.</u>	<u>DESCRIPTION</u>
<u>GENERAL</u>	
1	TITLE SHEET
2	INDEX OF SHEETS
3, 3A-3B	GENERAL NOTES
4	ESTIMATE & QUANTITY SHEET
5	QUANTITY SUMMARY
<u>TRAFFIC CONTROL PLAN</u>	
# 6-17	BC (1) -21 THRU BC (12) -21
# 18-23	TCP (2-1) -18 THRU TCP (2-6) -18
# 24	WZ (RS) -22
<u>ROADWAY DETAILS</u>	
# 25	MBGF -19
# 26	MBGF (SR) -19
# 27	MBGF (T101) -19
# 28	MBGF (TR) -19
# 29	GF (31) -19
# 30	GF (31) DAT -19
# 31	GF (31) LS -19
# 32	GF (31) T101 -19
# 33	GF (31) TR TL2 -19
# 34-35	GF (31) TR TL3 -20
# 36	RAIL -ADJ (A) -19
# 37	RAIL -ADJ (B) -19
# 38	SGT (10S) 31 -16
# 39	SGT (12S) 31 -18
# 40	SGT (15) 31 -20
# 41	CCCCG -22
# 42	QG (M) (W) -21
# 43	TAU (M) (N) -19
# 44	D&OM (1) -20
# 45	D&OM (3) -20
# 46	D&OM (VIA) -20
<u>BRIDGE ITEMS</u>	
# 47	T631 -CM
# 48-49	T631
# 50-51	T631LS
52	T2/T201 (MOD)
53	T202TR (MOD)
# 54	BED (28) -19
# 55	BED -14
<u>INFORMATIONAL SHEETS</u>	
56	"AS BUILT" TYPE T101
57	"AS BUILT" TYPE T6
58-60	"AS BUILT" TYPE T101RC (MOD)
<u>ENVIRONMENTAL</u>	
61	EPIC

THE STANDARD SHEETS SPECIFICALLY IDENTIFIED BY * HAVE BEEN SELECTED BY ME OR UNDER MY RESPONSIBLE SUPERVISION AS BEING APPLICABLE TO THIS PROJECT.

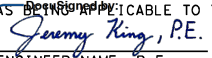
 ENGINEER NAME: Jeremy King, P.E. DATE: 12/6/2022
5135292FE416A4..



INDEX OF SHEETS

© 2023  Texas Department of Transportation

CONT	SECT	JOB	HIGHWAY
6417	38	001	US 96, etc.
DIST	COUNTY	SHEET NO.	
LFK	San Augustine	2	

11/17/2022 1:50:33 PM T:\LFK\DOM\Maint Contracts\0..RMC - Routine Maintenance Contracts\FY23 Plans\6417-38-001 San Augustine.MBGF.dgn

Project Number: RMC 6417-38-001**Control:** 6417-38-001**County:** San Augustine**Highway:** US 96, ETC.**GENERAL NOTES:**

PROJECT DESCRIPTION: This project consists of Repair/Upgrade Metal Beam Guard Fence, Crash Attenuator Systems and Bridge Rail, on a call-out basis in the San Augustine County Maintenance Section.

TxDOT Project Supervisors: All work on this contract will be scheduled and directed by the Maintenance Section Supervisor(s) listed below. Payment will be made on a monthly basis for work completed and accepted according to specifications. All payment requests should be directed to the Maintenance Section Supervisor(s) listed below.

<u>COUNTY</u>	<u>SUPERVISOR</u>	<u>ADDRESS</u>	<u>CONTACT #</u>
San Augustine	Scott Duffey	551 S. El Camino Crossing San Augustine, TX 75972	(936) 275-9671

Contract Prosecution: Each contract awarded by the Department stands on its own and, as such, is separate from other contracts. A Contractor awarded multiple contracts must be capable and sufficiently staffed to concurrently process any or all contracts at the same time.

Existing regulatory, warning and guide signs within project limits are to remain visible to the traveling public at all times. If a sign must be repositioned during construction operations, move and install the sign to an approved location. Use care when working near existing signs and repair or replace signs damaged by work operations. All work involved repositioning existing signs will be subsidiary to various bid items.

There is a potential for work to be done in environmentally sensitive areas within these maintenance sections. All work shall be performed as directed by the appropriate Maintenance Section Supervisor to avoid impacts to these areas.

Minimize vehicles and equipment in construction areas to lessen the impact on existing vegetation. The intent of the plans is to prepare only that portion of TxDOT right-of-way necessary for construction.

All workers on TxDOT right-of-way shall wear reflective clothing meeting ANSI Class II requirements during the day and ANSI Class III requirements during the night. Non-compliance with any of these requirements shall be grounds for suspension of work.

The following standard detail sheets have been modified:

T2/T201TR
T202TR

Contractor questions will only be accepted via email to the individuals listed below:

Jeremy King Jeremy.King@TxDOT.gov
Tammy Gibson Tamara.Gibson@TxDOT.gov

Project Number: RMC 6417-38-001**Control:** 6417-38-001**County:** San Augustine**Highway:** US 96, ETC.

All contractor questions will be reviewed by the Engineer. Once a response is developed, it will be posted on TxDOT's Public FTP at the following Address:

<https://ftp.dot.state.tx.us/pub/txdot-info/Pre-Letting%20Responses/>

All questions submitted that generate a response will be posted through this site. The site is organized by District, Project Type (Construction or Maintenance), Letting Date, CCSJ/Project Name.

This contract is for non-site-specific callout work. This is not a production contract. Callouts will be issued by Work Order containing work locations, approximate items of work and quantities along with the number of working days allowed for Work Order.

ITEM 2: INSTRUCTIONS TO BIDDERS

View plans on-line or download from the web at:

http://www.txdot.gov/business/contractors_consultants/plans_online.htm

Order plans from any of the plan reproduction companies shown on the web at:

http://www.dot.state.tx.us/business/contractors_consultants/repro_companies.htm

ITEM 4: SCOPE OF WORK

The contract may be extended if in the judgment of the Engineer, the Contractor has satisfactorily fulfilled the terms and conditions of the contract. The extension must be agreed upon in writing by both parties to the contract and may be extended for an additional period of time not to exceed the original contract time period. The extended contract may be for additional quantities up to the original bid quantities plus any quantities added by an approved change order. The extensions will meet the terms and conditions of the original contract or any mutually agreed modifications to the said terms and conditions by one or more cumulative change orders. The Engineer will set a deadline for completing the agreements. This deadline will be based on the time needed to re-let and award a new contract if no extension is agreed upon.

ITEM 5: CONTROL OF THE WORK

The Contractor shall become knowledgeable of the location of utilities within the right of way and shall use care when working near them.

Project Number: RMC 6417-38-001**Control:** 6417-38-001**County:** San Augustine**Highway:** US 96, ETC.**ITEM 7: LEGAL RELATIONS AND RESPONSIBILITIES**

The proposed work of this project is to repair/upgrade damaged guard fence, attenuator, and metal rail within the State right-of-way that may affect the safety of the traveling public. This activity maintains the original line and grade, hydraulic capacity and original purpose of the site. Therefore, this project meets the definition of a routine maintenance activity as defined in the TPDES General Permit No. TXR150000 issued March 5, 2018 and TCEQ's TPDES CGP does not apply.

"In order to maintain compliance with Chapter 64 of the Texas Parks and Wildlife Code and Migratory Bird Treaty Act (MBTA), construction activities that may affect nests (i.e. tree removal, tree limbing, bridge work) shall be conducted outside of the nesting season (March 15 to September 15). In the event birds or active nests (eggs and/or nestlings present) are encountered, contact the engineer prior to conducting work.

1. Red-cockaded woodpecker (federally listed endangered species) habitat is present adjacent to the ROW along SH 103, SH 147, and FM 1992. Conservation measures have been agreed upon by the United States Fish and Wildlife Service and TxDOT to ensure that the proposed action will not adversely affect the red-cockaded woodpecker. The conservation measures below must be followed in order to be in compliance with the Endangered Species Act.

1. NO WORK shall be performed at the below limits from April 1 to July 31
2. Work shall begin one hour after sunrise and cease one hour before sunset.
3. No STOCKPILES or EQUIPMENT STORAGE shall be allowed along or within ROW along SH 103, 147, and FM 1992.
 - On SH 103 from .25 miles west of FR 301 to 1.4 miles east of FR 301
 - On SH 147 from .50 miles south of SH 103 to 3.6 miles south of SH 103
 - On FM 1992 from .90 miles north of SH 103 to 1.6 miles north of SH 103

2. Texas golden gladeecress (federally-listed endangered species) Critical Habitat is present within the ROW along SH 21 from 0.5 mi East of LP 547 to 1.2 mi East of LP 547; along FM 353 from 0.8 mi East of SH 147 to 1.02 mi East of SH 147; along FM 3483 from 0.16 mi South of SH 21 to 0.63 mi South of SH 21 and from 0.82 mi South of SH 21 to 0.90 mi South of SH 21. No vehicles leaving the road or stockpiling is allowed to occur at these locations.

3. White bladderpod (federally-listed endangered species) is present within the ROW along SH 21 from 1.20 mi. West of FM 354 to 1.14 mi. West of FM 354 and along FM 3483 from 0.82 mi. South of SH 21 to 0.90 mi. South of SH 21. No vehicles leaving the road or stockpiling is allowed to occur at these locations."

Project Number: RMC 6417-38-001**Control:** 6417-38-001**County:** San Augustine**Highway:** US 96, ETC.**ITEM 8: PROSECUTION AND PROGRESS**

For this project, calendar days will be computed and charged in accordance with Item 8, Section 3.1.5 "Calendar Day."

Contract Time: The number of working days for this project shall be 365 days or until contract funds are expended.

Work requests are made on a callout basis. Begin physical work within 72 hours of notifications, unless otherwise approved by the Engineer.

ITEM 9: MEASUREMENT AND PAYMENT

This Contract includes callout work. In accordance with Article 9.2., "Plans Quantity Measurement", plans quantity measurement requirements are not applicable. The quantities shown are for estimates only and payment will be based on the actual quantities placed.

NONCOMPLIANCE PENALTY – A penalty will be assessed for each instance the contractor is in noncompliance. A noncompliance instance is defined by the following:

1. The contractor fails to begin work at the specified time and/or location(s).
2. The contractor does not have all the personnel and pieces of equipment necessary to fulfill of the item(s) called out at the specified time and/or location(s).
3. The contractor does not complete the work continuously, unless approved by the Engineer.

The Noncompliance Penalty will be deducted from any money due or to become due for any completed item(s) of work. The Noncompliance Penalty will be assessed as follows: \$250 per instance, per location.

ITEM 502: BARRICADES, SIGNS, AND TRAFFIC HANDLING

Traffic Control Plan (TCP):

Furnish and maintain all warning signs, flaggers, channelizing devices, etc. required for traffic control on this contract in accordance with Item 502.1 & 502.2. This work will not be paid for directly but will be considered subsidiary to the various bid items.

For protection of the traveling public, direct traffic through the work area using signs, flaggers and other devices. Required signs are shown in the plans on the Barricade and Construction Standards and Traffic Control Plan Sheets. The latest edition of the "Texas Manual on Uniform Traffic Control Devices" shall also be used as a guide for handling traffic on this project.

Project Number: RMC 6417-38-001**Control:** 6417-38-001**County:** San Augustine**Highway:** US 96, ETC.

Texas Transportation Code 547.105 authorizes the use of warning lights to promote safety and provides an effective means of gaining the travelling public's attention as they drive in areas where construction crews are present. In order to influence the public to move over when high risk construction activities are taking place, minimize the utilization of blue warning lights. These lights must be used only while performing work on or near the travel lanes or shoulder where the travelling public encounters construction crews that are not protected by a standard work zone set up such as a lane closure, shoulder closure, or one-way traffic control. Refrain from leaving the warning lights engaged while travelling from one work location to another or while parked on the right of way away from the pavement or a work zone.

Restrict construction work to single lane widths with only minor disruptions in traffic flow. Lane closures shall conform to the traffic control plan for lane closures as shown in the plans. No overnight closures will be permitted.

Provide temporary Rumble Strips as shown on work zone standards when lane closures are necessary.

Provide a flashing arrow panel and a truck-mounted attenuator to supplement required signs and devices for each lane closure.

Department-approved safety vests will be worn by all contractor's employees and visitors. Provide adequate flaggers to protect the traveling public. All flaggers shall wear approved hardhats and reflective safety vests while flagging. Safety vests shall be clean and worn fully fastened.

Install "Be Prepared to Stop" (CW20-7B) and "Flagger Ahead" (CW22-7D) signs when flaggers are present. Position the signs where good visibility and traffic control can be maintained.

Provide one high-intensity yellow, rotating dome-light on all equipment such as distributors, spreader boxes, lay-down machines, rollers, backhoes, road graders, loaders, etc. Mount lights high enough to be visible from all directions and operating when the equipment is within 30 ft. of the travel way. On all other equipment such as trucks, trailers, automobiles, etc., use emergency flashers while within the work zone.

No lane closures will be allowed after 12:00 Noon on Fridays or on days preceding Major Holidays, on US 59 and US 190 unless otherwise directed.

Plan the sequence of work so as to minimize the time lane closures are in place.

All traffic control for this project, with the exception of Item 6185: Truck Mounted Attenuator, shall be subsidiary to the various bid items.

ITEM 540: METAL BEAM GUARD FENCE & ITEM 770: GUARD FENCE REPAIR

GF(31)-19, GF(31)DAT-19, GF(31)LS-19, GF(31)TI101-19, GF(31)TR-19, GF(31)TRTL2-19, GF(31)TRTL3-20, RAIL-ADJ(A)-19, RAIL-ADJ(B)-19, SGT(10S)31-16, SGT(12S)31-18, SGT(15)31-20, BED (28)-19 & BED-14 standards shall be used on upgrades unless otherwise directed by the Engineer.

General Notes**Sheet 3B****Project Number:** RMC 6417-38-001**Control:** 6417-38-001**County:** San Augustine**Highway:** US 96, ETC.

All materials removed and deemed salvageable by the maintenance section supervisors shall be hauled to and neatly stockpiled at the San Jacinto County Maintenance Section yard at 8066 SH 150 in Shepherd. All non-salvageable materials shall become the property of the Contractor.

All materials furnished by the Contractor shall be new.

Existing concrete that will conflict with installing the new system shall be completely removed and disposed of by the Contractor. This work will not be paid for directly but shall be considered subsidiary to removal of the existing guardrail terminal.

Timber posts shall be domed. When posts are placed, new posts shall match the existing post such that each is uniform in height.

At the close of work each day, if repairs are not complete, the Contractor shall protect the ends of metal beam guard fence in an approved manner, so that no blunt ends are exposed to approaching traffic. Plastic drums will be required at these locations.

Completely clean the area of all debris including debris left from reconstruction of the Guardrail or Bridge Rail assembly as well as any litter created by the crew. Remove or spread surplus soil and material that has collected under the rail to the natural grade of the surrounding area.

ITEM 770: GUARD FENCE REPAIR

Do not mix parts on SGT's. Use only manufacture parts for each.

ITEM 774: ATTENUATOR REPAIR

The contractor shall furnish details on the method proposed to "Retrofit" the new systems at the existing crash cushion locations, prior to beginning this work. FASTRACC Systems will be furnished by TxDOT.

ITEM 6185: TRUCK MOUNTED ATTENUATOR (TMA)

Truck Mounted Attenuators (TMA's) shall meet the requirements of this item and the Department's Compliant Work Zone Traffic Control Device List.

Truck Mounted Attenuators (TMA's) as shown on the TCP's shall be used. Whether shown on the TCP's or added by the Department, TMA's shall be paid for under Item 6185, "Truck Mounted Attenuator (Stationary)".

General Notes**Sheet 3B**



CONTROLLING PROJECT ID 6417-38-001

DISTRICT Lufkin
HIGHWAY US0096,etc.

COUNTY San Augustine,etc.

Estimate & Quantity Sheet

CONTROL SECTION JOB				6417-38-001		TOTAL EST.	TOTAL FINAL
PROJECT ID				A00190472			
COUNTY				San Augustine			
HIGHWAY				US0096			
ALT	BID CODE	DESCRIPTION	UNIT	EST.	FINAL		
	450-6018	RAIL (TY T631)	LF	75.000		75.000	
	500-6033	MOBILIZATION (CALLOUT)	EA	12.000		12.000	
	540-6001	MTL W-BEAM GD FEN (TIM POST)	LF	800.000		800.000	
	540-6006	MTL BEAM GD FEN TRANS (THRIE-BEAM)	EA	4.000		4.000	
	540-6008	MTL BEAM GD FEN TRANS (T101)	EA	8.000		8.000	
	542-6001	REMOVE METAL BEAM GUARD FENCE	LF	2,000.000		2,000.000	
	542-6002	REMOVE TERMINAL ANCHOR SECTION	EA	6.000		6.000	
	544-6001	GUARDRAIL END TREATMENT (INSTALL)	EA	6.000		6.000	
	658-6016	INSTL DEL ASSM (D-SW)SZ (BRF)GF1 (BI)	EA	10.000		10.000	
	770-6001	REPAIR RAIL ELEMENT (W - BEAM)	LF	1,200.000		1,200.000	
	770-6010	REM / REPL TIMBER/STL POST W/O CONC FND	EA	75.000		75.000	
	770-6011	REM / REPL TIMBER / STL POST W/CONC FND	EA	15.000		15.000	
	770-6016	REPAIR STEEL POST WITH BASE PLATE	EA	10.000		10.000	
	770-6017	REALIGN POSTS	EA	30.000		30.000	
	770-6018	INSTALL BLOCKOUT (TYPE SPECIFIED)	EA	15.000		15.000	
	770-6019	REMOVE & REPLACE BLOCKOUT	EA	5.000		5.000	
	770-6021	REPLACE SINGLE GDRAIL TERMINAL RAIL	LF	125.000		125.000	
	770-6022	REPLACE SINGLE GDRAIL TERMINAL POST	EA	15.000		15.000	
	770-6023	REPAIR OF TERMINAL ANCHORS POSTS	EA	20.000		20.000	
	770-6027	REMOVE GDRAIL END TRT / REPL WITH SGT	EA	6.000		6.000	
	770-6028	REPL SINGLE GDRAIL TERM IMPACT HEAD	EA	8.000		8.000	
	770-6029	REM & RESET SGT IMPACT HEAD	EA	8.000		8.000	
	770-6034	REPAIR RAIL ELEMENT(W - BEAM FURNISHED)	LF	50.000		50.000	
	774-6017	REPAIR (WIDE QUAD)	EA	2.000		2.000	
	776-6020	REPAIR (TY T101RC)	LF	25.000		25.000	
	6185-6002	TMA (STATIONARY)	DAY	20.000		20.000	

DISTRICT	COUNTY	CCSJ	SHEET
Lufkin	San Augustine	6417-38-001	4

12/6/2023 12:30:47 PM T:\LF\DDM\Maint. Contracts\0..RMC - Routine Maintenance Contracts\FY23 Plans\6417-38-001 San Augustine MEGF\DDN\OSUM.dgn

SUMMARY OF GUARD FENCE, ATTENUATOR & RAIL UPGRADE/REPAIR ITEMS			
ITEM NO.	DESCRIPTION	UNIT	QUANTITY
0450 6018	RAIL (TY T631)	LF	75
0500 6033	MOBILIZATION (CALLOUT)	EA	12
0540 6001	MTL W-BEAM GD FEN (TIM POST)	LF	800
0540 6006	MTL BEAM GD FEN TRANS (THRIE-BEAM)	EA	4
0540 6008	MTL BEAM GD FEN TRANS (T101)	EA	8
0542 6001	REMOVE METAL BEAM GUARD FENCE	LF	2,000
0542 6002	REMOVE TERMINAL ANCHOR SECTION	EA	6
0544 6001	GUARDRAIL END TREATMENT (INSTALL)	EA	6
0658 6016	INSTL DEL ASSM (D-SW)SZ (BRF)GF1 (BI)	EA	10
0770 6001	REPAIR RAIL ELEMENT (W - BEAM)	LF	1,200
0770 6010	REM / REPL TIMBER/STL POST W/O CONC FND	EA	75
0770 6011	REM / REPL TIMBER / STL POST W/CONC FND	EA	15
0770 6016	REPAIR STEEL POST WITH BASE PLATE	EA	10
0770 6017	REALIGN POSTS	EA	30
0770 6018	INSTALL BLOCKOUT (TYPE SPECIFIED)	EA	15
0770 6019	REMOVE & REPLACE BLOCKOUT	EA	5
0770 6021	REPLACE SINGLE GDRAIL TERMINAL RAIL	LF	125
0770 6022	REPLACE SINGLE GDRAIL TERMINAL POST	EA	15
0770 6023	REPAIR OF TERMINAL ANCHORS POSTS	EA	20
0770 6027	REMOVE GDRAIL END TRT / REPL WITH SGT	EA	6
0770 6028	REPL SINGLE GDRAIL TERM IMPACT HEAD	EA	8
0770 6029	REM & RESET SGT IMPACT HEAD	EA	8
0770 6034	REPAIR RAIL ELEMENT(W - BEAM FURNISHED)	LF	50
0774 6017	REPAIR (WIDE QUAD)	EA	2
0776 6020	REPAIR (TY T101RC)	LF	25
6185 6002	TMA (STATIONARY)	DAY	20

QUANTITY SUMMARY

2023 			
CONT	SECT	JOB	HIGHWAY
6417	38	001	US 96, etc.
DIST	COUNTY		SHEET NO.
LFK	San Augustine		5

DISCLAIMER: The use of this standard is governed by the "Texas Engineering Practice Act". No warranty of any kind is made by the Board of Professional Engineers, Architects, and Surveyors of the State of Texas, or any of its members, for the use of this standard for any purpose other than that intended. The Board of Professional Engineers, Architects, and Surveyors of the State of Texas, or any of its members, shall not be liable for any damages, including reasonable attorneys' fees, arising out of the use of this standard. The use of this standard is approved by the Board of Professional Engineers, Architects, and Surveyors of the State of Texas, or any of its members, on August 11, 2002. The use of this standard is approved by the Board of Professional Engineers, Architects, and Surveyors of the State of Texas, or any of its members, on August 11, 2002. The use of this standard is approved by the Board of Professional Engineers, Architects, and Surveyors of the State of Texas, or any of its members, on August 11, 2002.

BARRICADE AND CONSTRUCTION (BC) STANDARD SHEETS GENERAL NOTES:

- The Barricade and Construction Standard Sheets (BC sheets) are intended to show typical examples for placement of temporary traffic control devices, construction pavement markings, and typical work zone signs. The information contained in these sheets meet or exceed the requirements shown in the "Texas Manual on Uniform Traffic Control Devices" (TMUTCD).
- The development and design of the Traffic Control Plan (TCP) is the responsibility of the Engineer.
- The Contractor may propose changes to the TCP that are signed and sealed by a licensed professional engineer for approval. The Engineer may develop, sign and seal Contractor proposed changes.
- The Contractor is responsible for installing and maintaining the traffic control devices as shown in the plans. The Contractor may not move or change the approximate location of any device without the approval of the Engineer.
- Geometric design of lane shifts and detours should, when possible, meet the applicable design criteria contained in manuals such as the American Association of State Highway and Transportation Officials (AASHTO), "A Policy on Geometric Design of Highways and Streets," the TxDOT "Roadway Design Manual" or engineering judgment.
- When projects abut, the Engineer(s) may omit the END ROAD WORK, TRAFFIC FINES DOUBLE, and other advance warning signs if the signing would be redundant and the work areas appear continuous to the motorists. If the adjacent project is completed first, the Contractor shall erect the necessary warning signs as shown on these sheets, the TCP sheets or as directed by the Engineer. The BEGIN ROAD WORK NEXT X MILES sign shall be revised to show appropriate work zone distance.
- The Engineer may require duplicate warning signs on the median side of divided highways where median width will permit and traffic volumes justify the signing.
- All signs shall be constructed in accordance with the details found in the "Standard Highway Sign Designs for Texas," latest edition. Sign details not shown in this manual shall be shown in the plans or the Engineer shall provide a detail to the Contractor before the sign is manufactured.
- The temporary traffic control devices shown in the illustrations of the BC sheets are examples. As necessary, the Engineer will determine the most appropriate traffic control devices to be used.
- Where highway construction or maintenance work is being undertaken, other than mobile operations as defined by the Texas Manual on Uniform Traffic Control Devices, CSJ limit signs are required. CSJ limit signs are shown on BC(2). The OBEY WARNING SIGNS STATE LAW sign, STAY ALERT TALK OR TEXT LATER and the WORK ZONE TRAFFIC FINES DOUBLE sign with plaque shall be erected in advance of the CSJ limits. The BEGIN ROAD WORK NEXT X MILES, CONTRACTOR and END ROAD WORK signs shall be erected at or near the CSJ limits. For mobile operations, CSJ limit signs are not required.
- Traffic control devices should be in place only while work is actually in progress or a definite need exists.
- The Engineer has the final decision on the location of all traffic control devices.
- Inactive equipment and work vehicles, including workers' private vehicles must be parked away from travel lanes. They should be as close to the right-of-way line as possible, or located behind a barrier or guardrail, or as approved by the Engineer.

WORKER SAFETY NOTES:

- Workers on foot who are exposed to traffic or to construction equipment within the right-of-way shall wear high-visibility safety apparel meeting the requirements of ISEA "American National Standard for High-Visibility Apparel," or equivalent revisions, and labeled as ANSI 107-2004 standard performance for Class 2 or 3 risk exposure. Class 3 garments should be considered for high traffic volume work areas or night time work.
- Except in emergency situations, flagger stations shall be illuminated when flagging is used at night.

COMPLIANT WORKZONE TRAFFIC CONTROL DEVICES

- Only pre-qualified products shall be used. The "Compliant Work Zone Traffic Control Devices List" (CWZTCD) describes pre-qualified products and their sources.
- Work zone traffic control devices shall be compliant with the Manual for Assessing safety Hardware (MASH).

<p>THE DOCUMENTS BELOW CAN BE FOUND ON-LINE AT http://www.txdot.gov</p>
COMPLIANT WORK ZONE TRAFFIC CONTROL DEVICES LIST (CWZTCD)
DEPARTMENTAL MATERIAL SPECIFICATIONS (DMS)
MATERIAL PRODUCER LIST (MPL)
ROADWAY DESIGN MANUAL - SEE "MANUALS (ONLINE MANUALS)"
STANDARD HIGHWAY SIGN DESIGNS FOR TEXAS (SHSD)
TEXAS MANUAL ON UNIFORM TRAFFIC CONTROL DEVICES (TMUTCD)
TRAFFIC ENGINEERING STANDARD SHEETS

SHEET 1 OF 12

 <p>Texas Department of Transportation</p>		<p>Traffic Safety Division Standard</p>	
<p>BARRICADE AND CONSTRUCTION GENERAL NOTES AND REQUIREMENTS</p> <p>BC(1) - 21</p>			
FILE:	bc-21.dgn	DN:	TxDOT
		CR:	TxDOT
		DN:	TxDOT
		CR:	TxDOT
REV	DATE	BY	REASON
4-03	7-13	6417	38 001 US 96, etc.
9-07	8-14		DIST COUNTY SHEET NO.
5-10	5-21	LFK	San Augustine 6

TYPICAL LOCATION OF CROSSROAD SIGNS

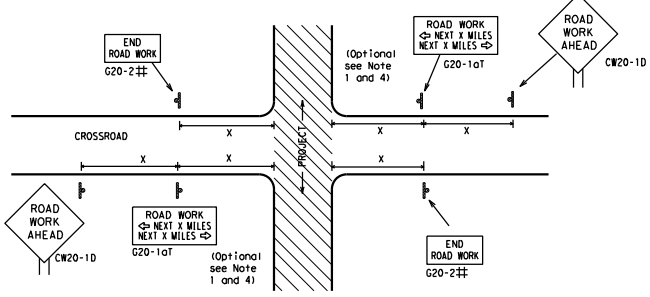

May be mounted on back of "ROAD WORK AHEAD" (CW20-1D) sign with approval of Engineer. (See note 2 below)

- The typical minimum signing on a crossroad approach should be a "ROAD WORK AHEAD" (CW20-1D) sign and a (G20-2) "END ROAD WORK" sign, unless noted otherwise in plans.
- The Engineer may use the reduced size 36" x 36" ROAD WORK AHEAD (CW20-1D) sign mounted back to back with the reduced size 36" x 18" "END ROAD WORK" (G20-2) sign on low volume crossroads (see Note 4 under "Typical Construction Warning Sign Size and Spacing"). See the "Standard Highway Sign Designs for Texas" manual for sign details. The Engineer may omit the advance warning signs on low volume crossroads. The Engineer will determine whether a road is low volume as per TMUTCD Part 5. This information shall be shown in the plans.
- Based on existing field conditions, the Engineer/Inspector may require additional signs such as FLAGGER AHEAD, LOOSE GRAVEL, or other appropriate signs. When additional signs are required, these signs will be considered part of the minimum requirements. The Engineer/Inspector will determine the proper location and spacing of any sign not shown on the BC sheets, Traffic Control Plan sheets or the Work Zone Standard Sheets.
- The "ROAD WORK NEXT X MILES" (G20-1aT) sign shall be required at high volume crossroads to advise motorists of the length of construction in either direction from the intersection. The Engineer will determine whether a roadway is considered high volume.
- Additional traffic control devices may be shown elsewhere in the plans for higher volume crossroads.
- When work occurs in the intersection area, appropriate traffic control devices, as shown elsewhere in the plans or as determined by the Engineer/Inspector, shall be in place.

T-INTERSECTION

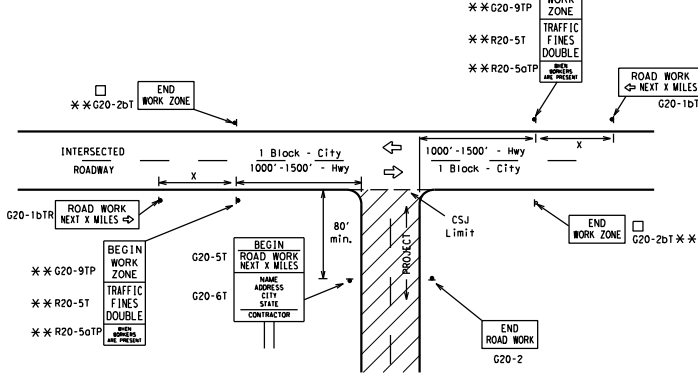

CSJ LIMITS AT T-INTERSECTION

- The Engineer will determine the types and location of any additional traffic control devices, such as a flagger and accompanying signs, or other signs, that should be used when work is being performed at or near an intersection.
- If construction closes the road at a T-intersection, the Contractor shall place the "CONTRACTOR NAME" (G20-6T) sign behind the Type 3 Barricades for the road closure (see BC(10) also). The "ROAD WORK NEXT X MILES" left arrow (G20-1bTL) and "ROAD WORK NEXT X MILES" right arrow (G20-1bTR) signs shall be replaced by the detour signing called for in the plans.

TYPICAL CONSTRUCTION WARNING SIGN SIZE AND SPACING^{15.6}

Sign Number or Series	SIZE		SPACING	
	Conventional Road	Expressway/Freeway	Posted Speed MPH	Sign Spacing "X" Feet (Approx.)
CW20 ⁴ CW21 CW22 CW23 CW25	48" x 48"	48" x 48"	30	120
			35	160
			40	240
			45	320
CW1, CW2, CW7, CW8, CW9, CW11, CW14	36" x 36"	48" x 48"	50	400
			55	500 ²
			60	600 ²
			65	700 ²
			70	800 ²
CW3, CW4, CW5, CW6, CW8-3, CW10, CW12	48" x 48"	48" x 48"	75	900 ²
			80	1000 ²
			*	*
			*	*

* For typical sign spacings on divided highways, expressways and freeways, see Part 6 of the "Texas Manual on Uniform Traffic Control Devices" (TMUTCD) typical application diagrams or TCP Standard Sheets.

△ Minimum distance from work area to first Advance Warning sign nearest the work area and/or distance between each additional sign.

GENERAL NOTES

- Special or larger size signs may be used as necessary.
- Distance between signs should be increased as required to have 1500 feet advance warning.
- Distance between signs should be increased as required to have 1/2 mile or more advance warning.
- 36" x 36" "ROAD WORK AHEAD" (CW20-1D) signs may be used on low volume crossroads at the discretion of the Engineer as per TMUTCD Part 5. See Note 2 under "Typical Location of Crossroad Signs".
- Only diamond shaped warning sign sizes are indicated.
- See sign size listing in "TMUTCD", Sign Appendix or the "Standard Highway Sign Designs for Texas" manual for complete list of available sign design sizes.

WORK AREAS IN MULTIPLE LOCATIONS WITHIN CSJ LIMITS

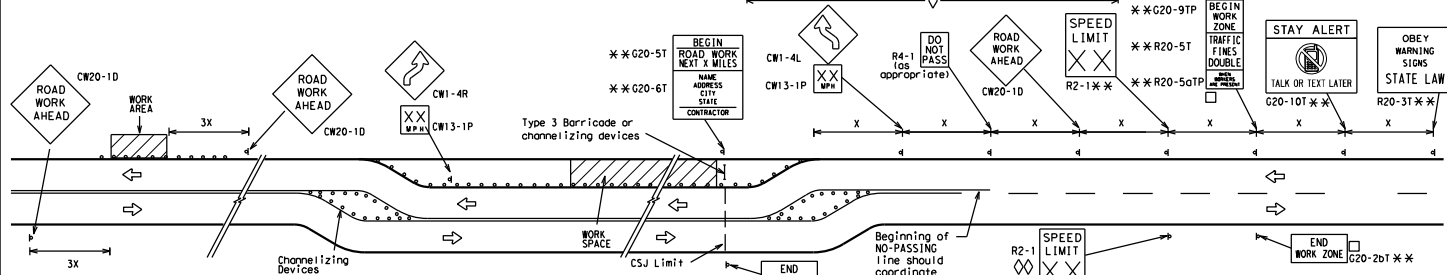

When extended distances occur between minimal work spaces, the Engineer/Inspector should ensure additional "ROAD WORK AHEAD" (CW20-1D) signs are placed in advance of these work areas to remind drivers they are still within the project limits. See the applicable TCP sheets for exact location and spacing of signs and channelizing devices.

SAMPLE LAYOUT OF SIGNING FOR WORK BEGINNING AT THE CSJ LIMITS

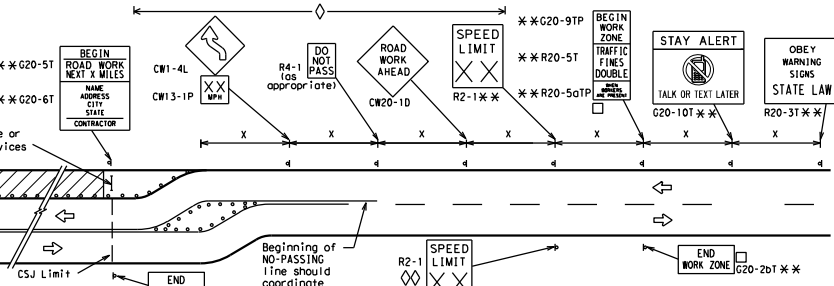

SAMPLE LAYOUT OF SIGNING FOR WORK BEGINNING DOWNSTREAM OF THE CSJ LIMITS

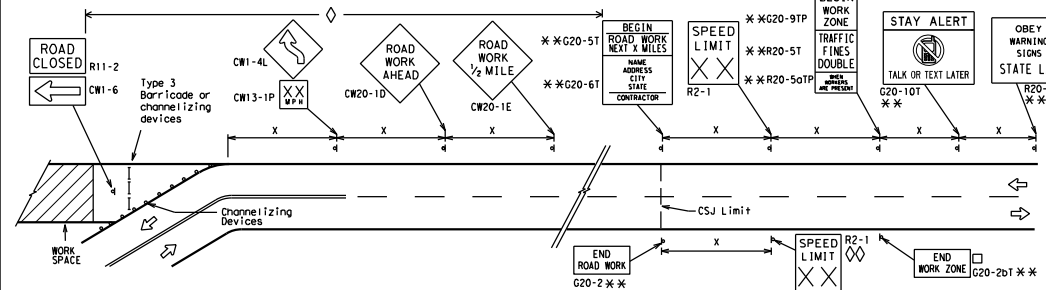

NOTES

- The Contractor shall determine the appropriate distance to be placed on the G20-1 series signs and "BEGIN ROAD WORK NEXT X MILES" (G20-5T) sign for each specific project. This distance shall replace the "X" and shall be rounded to the nearest whole mile with the approval of the Engineer. No decimals shall be used.
- The "BEGIN WORK ZONE" (G20-9TP) and "END WORK ZONE" (G20-2bT) shall be used as shown on the sample layout when advance signs are required outside the CSJ Limits. They inform the motorist of entering or leaving a part of the work zone lying outside the CSJ Limits where traffic fines may double if workers are present.
 - CSJ limit signing is required for highway construction and maintenance work, with the exception of mobile operations.
 - Area for placement of "ROAD WORK AHEAD" (CW20-1D) sign and other signs or devices as called for on the Traffic Control Plan.
 - Contractor will install a regulatory speed limit sign at the end of the work zone.

LEGEND

	Type 3 Barricade
	Channelizing Devices
	Sign
	See Typical Construction Warning Sign Size and Spacing chart or the TMUTCD for sign spacing requirements.

SHEET 2 OF 12

Texas Department of Transportation
Traffic Safety Division

BARRICADE AND CONSTRUCTION PROJECT LIMIT

BC(2)-21

FILE: bc-21.dgn	DATE: 7-13	BY: LFK	CHECKED: 8-14	APPROVED: 5-21
© TxDOT November 2002	REV: 6417	SECTION: 38	JOB: 001	COUNTY: US 96, etc.
REVISIONS	DATE: 9-07	BY: 8-14	BY: 7-13	SHEET NO. 7
	DATE: 7-13	BY: 5-21	BY:	
				San Augustine

DISCLAIMER: The use of this standard is governed by the "Texas Engineering Practice Act". No warranty of any kind is made by the Texas Department of Transportation, its employees, or its consultants, for the conversion of this standard to metric units. The use of this standard is subject to the terms and conditions of the license agreement. DATE: 11/17/2022 12:52:35 PM FILE: T:\LK\KDM\Main\Contractors\0-RMC - Routine Maintenance Contracts\123-001 - San Augustine\BARRICADE AND CONSTRUCTION PROJECT LIMIT BC(2)-21.dgn

TYPICAL APPLICATION OF WORK ZONE SPEED LIMIT SIGNS

Work zone speed limits shall be regulatory, established in accordance with the "Procedures for Establishing Speed Zones," and approved by the Texas Transportation Commission, or by City Ordinance when within Incorporated City Limits.

Reduced speeds should only be posted in the vicinity of work activity and not throughout the entire project. Regulatory work zone speed signs (R2-1) shall be removed or covered during periods when they are not needed.

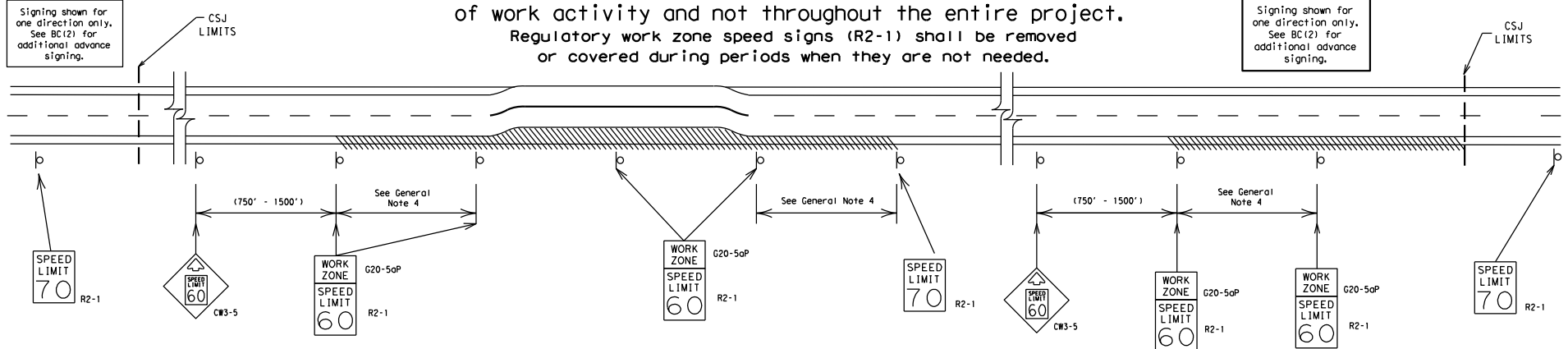

GUIDANCE FOR USE:

LONG/INTERMEDIATE TERM WORK ZONE SPEED LIMITS

This type of work zone speed limit should be included on the design of the traffic control plans when restricted geometrics with a lower design speed are present in the work zone and modification of the geometrics to a higher design speed is not feasible.

Long/Intermediate Term Work Zone Speed Limit signs, when approved as described above, should be posted and visible to the motorist when work activity is present. Work activity may also be defined as a change in the roadway that requires a reduced speed for motorists to safely negotiate the work area, including:

- a) rough road or damaged pavement surface
- b) substantial alteration of roadway geometrics (diversions)
- c) construction detours
- d) grade
- e) width
- f) other conditions readily apparent to the driver

As long as any of these conditions exist, the work zone speed limit signs should remain in place.

SHORT TERM WORK ZONE SPEED LIMITS

This type of work zone speed limit may be included on the design of the traffic control plans when workers or equipment are not behind concrete barrier, when work activity is within 10 feet of the traveled way or actually in the traveled way.

Short Term Work Zone Speed Limit signs should be posted and visible to the motorists only when work activity is present. When work activity is not present, signs shall be removed or covered. (See Removing or Covering on BC(4)).

GENERAL NOTES

1. Regulatory work zone speed limits should be used only for sections of construction projects where speed control is of major importance.
2. Regulatory work zone speed limit signs shall be placed on supports at a 7 foot minimum mounting height.
3. Speed zone signs are illustrated for one direction of travel and are normally posted for each direction of travel.
4. Frequency of work zone speed limit signs should be:
 - 40 mph and greater 0.2 to 2 miles
 - 35 mph and less 0.2 to 1 mile
5. Regulatory speed limit signs shall have black legend and border on a white reflective background (See "Reflective Sheeting" on BC(4)).
6. Fabrication, erection and maintenance of the "ADVANCE SPEED LIMIT" (CW3-5) sign, "WORK ZONE" (G20-5aP) plaque and the "SPEED LIMIT" (R2-1) signs shall not be paid for directly, but shall be considered subsidiary to Item 502.
7. Turning signs from view, laying signs over or down will not be allowed, unless as otherwise noted under "REMOVING OR COVERING" on BC(4).
8. Techniques that may help reduce traffic speeds include but are not limited to:
 - A. Low enforcement.
 - B. Flagger stationed next to sign.
 - C. Portable changeable message sign (PCMS).
 - D. Low-power (drone) radar transmitter.
 - E. Speed monitor trailers or signs.
9. Speeds shown on details above are for illustration only. Work Zone Speed Limits should only be posted as approved for each project.
10. For more specific guidance concerning the type of work, work zone conditions and factors impacting allowable regulatory construction speed zone reduction see TxDOT form #1204 in the TxDOT e-form system.

SHEET 3 OF 12

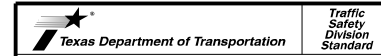

BARRICADE AND CONSTRUCTION WORK ZONE SPEED LIMIT

BC (3) - 21

FILE: dc-21.dgn	DN: TxDOT	CR: TxDOT	DR: TxDOT	EX: TxDOT
© TxDOT November 2002	CONT	SECT	JOB	HIGHWAY
REVISIONS	6417	38	001	US 96, etc.
9-07 8-14	DIST	COUNTY	SHEET NO.	
7-13 5-21	LFK	San Augustine	8	

DISCLAIMER: The use of this standard is governed by the "Texas Engineering Practice Act". No warranty of any kind is made by TxDOT for any purpose whatsoever. TxDOT assumes no responsibility for the conversion of units or the accuracy of the information contained herein. DATE: 11/17/2022 12:52:36 PM FILE: T:\LFK\DMaint\Contracts\00.RMC - Routine Maintenance Contracts\123 91083\0417238-001 SIGN AUGUSTINE WORK ZONE SPEED LIMIT BC(3)-21.dgn

DATE: 11/17/2022 12:52:36 PM FILE: T:\LFK\DMaint\Contracts\00.RMC - Routine Maintenance Contracts\123 91083\0417238-001 SIGN AUGUSTINE WORK ZONE SPEED LIMIT BC(3)-21.dgn

TYPICAL MINIMUM CLEARANCES FOR LONG TERM AND INTERMEDIATE TERM SIGNS

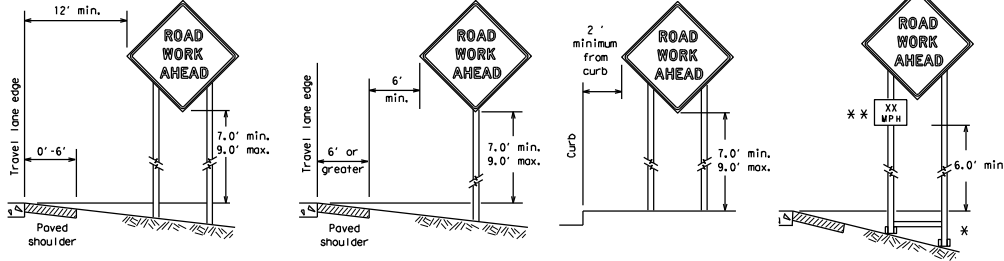

* When placing skid supports on unlevel ground, the leg post lengths must be adjusted so the sign appears straight and plumb. Objects shall NOT be placed under skids as a means of leveling.

** When plaques are placed on dual-leg supports, they should be attached to the upright nearest the travel lane. Supplemental plaques (advisory or distance) should not cover the surface of the nearest sign.

ATTACHMENT FOR SIGN SUPPORTS

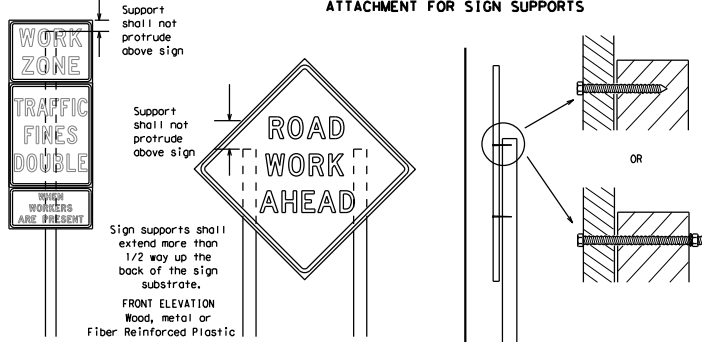

Attachment to wooden supports will be by bolts and nuts or screws. Use TxDOT's or manufacturer's recommended procedures for attaching sign substrates to other types of sign supports

Nails shall NOT be allowed.
Each sign shall be attached directly to the sign support. Multiple signs shall not be joined or spliced by any means. Wood supports shall not be extended or repaired by splicing or other means.

SIDE ELEVATION
Wood

Splicing embedded perforated square metal tubing in order to extend post height will only be allowed when the splice is made using four bolts, two above and two below the splice point. Splice must be located entirely behind the sign substrate, not near the base of the support. Splice insert lengths should be at least 5 times nominal post size, centered on the splice and of at least the same gauge material.

STOP/SLOW PADDLES

- STOP/SLOW paddles are the primary method to control traffic by flaggers. The STOP/SLOW paddle size should be 24" x 24".
- STOP/SLOW paddles shall be retroreflective when used at night.
- STOP/SLOW paddles may be attached to a staff with a minimum length of 6' to the bottom of the sign.
- Any lights incorporated into the STOP or SLOW paddle faces shall only be as specifically described in Section 6E.03 Hand Signaling Devices in the TMDOT.

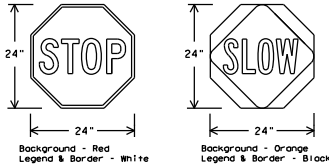

SHEETING REQUIREMENTS (WHEN USED AT NIGHT)		
USAGE	COLOR	SIGN FACE MATERIAL
BACKGROUND	RED	TYPE B OR C SHEETING
BACKGROUND	ORANGE	TYPE B _L OR C _L SHEETING
LEGEND & BORDER	WHITE	TYPE B OR C SHEETING
LEGEND & BORDER	BLACK	ACRYLIC NON-REFLECTIVE FILM

CONTRACTOR REQUIREMENTS FOR MAINTAINING PERMANENT SIGNS WITHIN THE PROJECT LIMITS

- Permanent signs are used to give notice of traffic laws or regulations, call attention to conditions that are potentially hazardous to traffic operations, show route designations, destinations, directions, distances, services, points of interest, and other geographical, recreational, specific service (L000), or cultural information. Drivers proceeding through a work zone need the same, if not better route guidance as normally installed on a roadway without construction.
- When permanent regulatory or warning signs conflict with work zone conditions, remove or cover the permanent signs until the permanent sign message matches the roadway condition. For details for covering large guide signs see the TS-CD standard.
- When existing permanent signs are moved and relocated due to construction purposes, they shall be visible to motorists at all times.
- If existing signs are to be relocated on their original supports, they shall be installed on crashworthy bases as shown on the SMD Standard sheets. The signs shall meet the required mounting heights shown on the BC sheets or the SMD Standards. This work should be paid for under the appropriate pay item for relocating existing signs.
- If permanent signs are to be removed and relocated using temporary supports, the Contractor shall use crashworthy supports as shown on the BC standard sheets, TLRs standard sheets or the CWZTCD list. The signs shall meet the required mounting heights shown on the BC, or the SMD standard sheets during construction. This work should be paid for under the appropriate pay item for relocating existing signs.
- Any sign or traffic control device that is struck or damaged by the Contractor or his/her construction equipment shall be replaced as soon as possible by the Contractor to ensure proper guidance for the motorists. This will be subsidiary to item 502.

GENERAL NOTES FOR WORK ZONE SIGNS

- Contractor shall install and maintain signs in a straight and plumb condition and/or as directed by the Engineer.
- Wooden sign posts shall be painted white.
- Barricades shall NOT be used as sign supports.
- All signs shall be installed in accordance with the plans or as directed by the Engineer. Signs shall be used to regulate, warn, and guide the traveling public safely through the work zone.
- The Contractor may furnish either the sign design shown in the plans or in the "Standard Highway Sign Designs for Texas" (SHSD). The Engineer/Inspector may require the Contractor to furnish other work zone signs that are shown in the TMDOT but may have been omitted from the plans. Any changes in the plans shall be documented by written agreement between the Engineer and the Contractor's Responsible Person. All changes must be documented in writing before being implemented. This can include documenting the changes in the Inspector's TxDOT diary and having both the Inspector and Contractor initial and date the agreed upon changes.
- The Contractor shall furnish sign supports listed in the "Compliant Work Zone Traffic Control Device List" (CWZTCD) for small roadside signs. Supports for temporary large roadside signs shall meet the requirements detailed on the Temporary Large Roadside Signs (TLRS) standard sheets. The Contractor shall install the sign support in accordance with the manufacturer's recommendations. If there is a question regarding installation procedures, the Contractor shall furnish the Engineer a copy of the manufacturer's installation recommendations so the Engineer can verify the correct procedures are being followed.
- The Contractor is responsible for installing signs on approved supports and replacing signs with damaged or cracked substrates and/or damaged or marred reflective sheeting as directed by the Engineer/Inspector.
- Identification markings may be shown only on the back of the sign substrate. The maximum height of letters and/or company logos used for identification shall be 1 inch.
- The Contractor shall replace damaged wood posts. New or damaged wood sign posts shall not be spliced.

DURATION OF WORK (as defined by the "Texas Manual on Uniform Traffic Control Devices" Part 6)

- The types of sign supports, sign mounting height, the size of signs, and the type of sign substrates can vary based on the type of work being performed. The Engineer is responsible for selecting the appropriate size sign for the type of work being performed. The Contractor is responsible for ensuring the sign support, sign mounting height and substrate meets manufacturer's recommendations in regard to crashworthiness and duration of work requirements.
 - Long-term stationary - work that occupies a location more than 3 days.
 - Intermediate-term stationary - work that occupies a location more than one daylight period up to 3 days, or nighttime work lasting more than one hour.
 - Short-term stationary - daytime work that occupies a location for more than 1 hour in a single daylight period.
 - Short, duration - work that occupies a location up to 1 hour.
 - Mobile - work that moves continuously or intermittently (stopping for up to approximately 15 minutes.)

SIGN MOUNTING HEIGHT

- The bottom of Long-term/Intermediate-term signs shall be at least 7 feet, but not more than 9 feet, above the paved surface, except as shown for supplemental plaques mounted below other signs.
- The bottom of Short-term/Short Duration signs shall be a minimum of 1 foot above the pavement surface but no more than 2 feet above the ground.
- Long-term/Intermediate-term Signs may be used in lieu of Short-term/Short Duration signing.
- Short-term/Short Duration signs shall be used only during daylight and shall be removed at the end of the workday or raised to appropriate Long-term/Intermediate sign height.
- Regulatory signs shall be mounted at least 7 feet, but not more than 9 feet, above the paved surface regardless of work duration.

SIZE OF SIGNS

- The Contractor shall furnish the sign sizes shown on BC (2) unless otherwise shown in the plans or as directed by the Engineer.

SIGN SUBSTRATES

- The Contractor shall ensure the sign substrate is installed in accordance with the manufacturer's recommendations for the type of sign support that is being used. The CWZTCD lists each substrate that can be used on the different types and models of sign supports.
- "Mesh" type materials are NOT an approved sign substrate, regardless of the tightness of the weave.
- All wooden individual sign panels fabricated from 2 or more pieces shall have one or more plywood cleat, 1/2" thick by 6" wide, fastened to the back of the sign and extending fully across the sign. The cleat shall be attached to the back of the sign using wood screws that do not penetrate the face of the sign panel. The screws shall be placed on both sides of the splice and spaced at 6' centers. The Engineer may approve other methods of splicing the sign face.

REFLECTIVE SHEETING

- All signs shall be retroreflective and constructed of sheeting meeting the color and retro-reflectivity requirements of DMS-8300 for rigid signs or DMS-8310 for roll-up signs. The web address for DMS specifications is shown on BC(1).
- White sheeting, meeting the requirements of DMS-8300 Type A, shall be used for signs with a white background.
- Orange sheeting, meeting the requirements of DMS-8300 Type B_L or Type C_L, shall be used for rigid signs with orange backgrounds.

SIGN LETTERS

- All sign letters and numbers shall be clear, and open rounded type uppercase alphabet letters as approved by the Federal Highway Administration (FHWA) and as published in the "Standard Highway Sign Design for Texas" manual. Signs, letters and numbers shall be of first class workmanship in accordance with Department Standards and Specifications.

REMOVING OR COVERING

- When sign messages may be confusing or do not apply, the signs shall be removed or completely covered.
- Long-term stationary or intermediate stationary signs installed on square metal tubing may be turned away from traffic 90 degrees when the sign message is not applicable. This technique may not be used for signs installed in the median of divided highways or near any intersections where the sign may be seen from approaching traffic.
- Signs installed on wooden skids shall not be turned at 90 degree angles to the roadway. These signs should be removed or completely covered when not required.
- When signs are covered, the material used shall be opaque, such as heavy mil black plastic, or other materials which will cover the entire sign face and maintain their opaque properties under automobile headlights at night, without damaging the sign sheeting.
- Burlap shall NOT be used to cover signs.
- Duct tape or other adhesive material shall NOT be affixed to a sign face.
- Signs and anchor studs shall be removed and holes backfilled upon completion of work.

SIGN SUPPORT WEIGHTS

- Where sign supports require the use of weights to keep from turning over, the use of sandbags with dry, coarsely graded sand shall be used and shall be tied shut to keep the sand from spilling and to maintain a constant weight.
- The sandbags will be tied shut to keep the sand from spilling and to maintain a constant weight.
- Rock, concrete, iron, steel or other solid objects shall not be permitted for use as sign supports.
- Sandbags should weigh a minimum of 35 lbs and a maximum of 50 lbs.
- Sandbags shall be made of a durable material that tears upon vehicular impact. Rubber (such as fire inner tubes) shall NOT be used.
- Rubber ballast used for channelizing devices should not be used for ballast on portable sign supports. Sign supports designed and manufactured with rubber balls may be used when shown on the CWZTCD list.
- Sandbags shall only be placed along or laid over the base supports of the traffic control device and shall not be suspended above ground level or hung with rope, wire, chains or other fasteners. Sandbags shall be placed along the length of the skids to weigh down the sign support.
- Sandbags shall NOT be placed under the skid and shall not be used to level sign supports placed on slopes.

FLAGS ON SIGNS

- Flags may be used to draw attention to warning signs. When used, the flag shall be 16 inches square or larger and shall be orange or fluorescent red-orange in color. Flags shall not be allowed to cover any portion of the sign face.

Texas Department of Transportation
Traffic Safety Division Standard

BARRICADE AND CONSTRUCTION TEMPORARY SIGN NOTES

BC (4) - 21

FILE: Dc-21.dgn	DNV: TxDOT	CK: TxDOT	DMV: TxDOT	CK: TxDOT
REVISED: 06/17/2002	CONF: 6417	SECT: 38	JOB: 001	US 96, etc.
9-07 8-14	DIST:	COUNTY:	SHEET NO:	
7-13 5-21	LFK	San Augustine	9	

DISCLAIMER: The use of this standard is governed by the "Texas Engineering Practice Act". No warranty, of any kind, is made by TxDOT for the use of this standard or for incorrect results or damages resulting from its use. This standard is published under the authority of the Texas Department of Transportation. Plans 6417-38-001, San Augustine MBR-DOCS-STANDARD-TRAFFIC-BC(1)-21, THRU BC(12)-21.dgn

DATE: 11/17/2022 12:52:36 PM
 FILE: T:\NF\KDM\mnt\contracts\0-RMC - Routine Maintenance Contracts\123 Plans\6417-38-001

DISCLAIMER: The use of this standard is governed by the "Texas Engineering Practice Act", which provides for the recovery of damages for negligent conversion. The use of this standard is not intended to be construed as a warranty, and it is not intended to be construed as a contract.

DATE: 11/17/2022 12:52:37 PM
 FILE: T:\LFD\MAINT\Contracts\0-RMC - Routine Maintenance Contracts\123 Plans\6417-38-001 San Augustine WBF-DORV-STANDARD-TRAFF-BC(5)-21-THRU-BC(11)-21-THRU-BC(12)-21.dgn

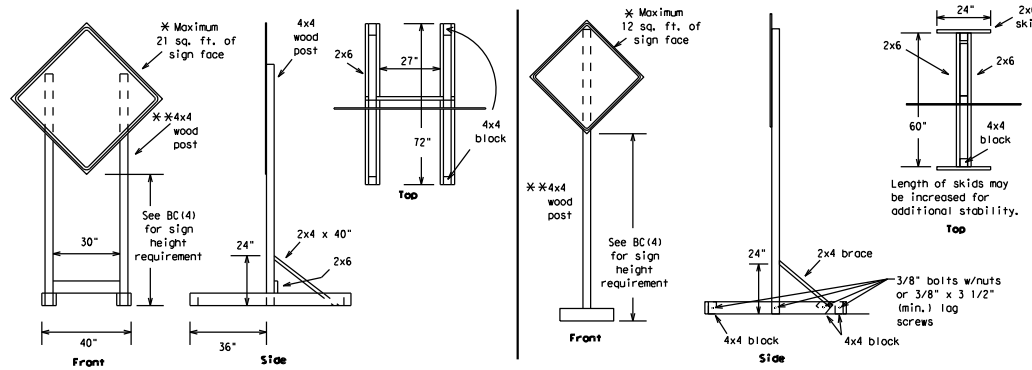

SKID MOUNTED WOOD SIGN SUPPORTS

* LONG/INTERMEDIATE TERM STATIONARY - PORTABLE SKID MOUNTED SIGN SUPPORTS

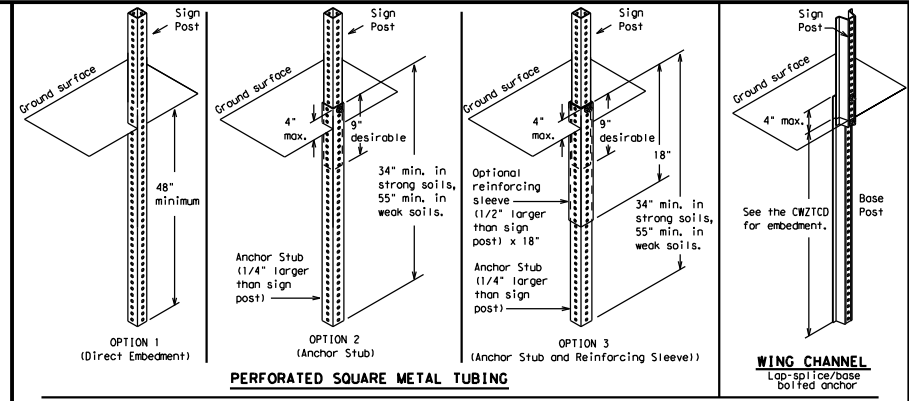

GROUND MOUNTED SIGN SUPPORTS

Refer to the CWZTCD and the manufacturer's installation procedure for each type sign support. The maximum sign square footage shall adhere to the manufacturer's recommendation. Two post installations can be used for larger signs.

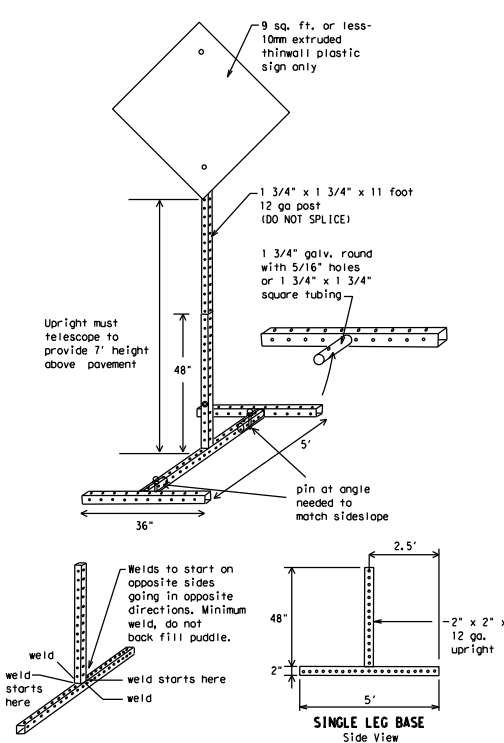

SKID MOUNTED PERFORATED SQUARE STEEL TUBING SIGN SUPPORTS

* LONG/INTERMEDIATE TERM STATIONARY - PORTABLE SKID MOUNTED SIGN SUPPORTS

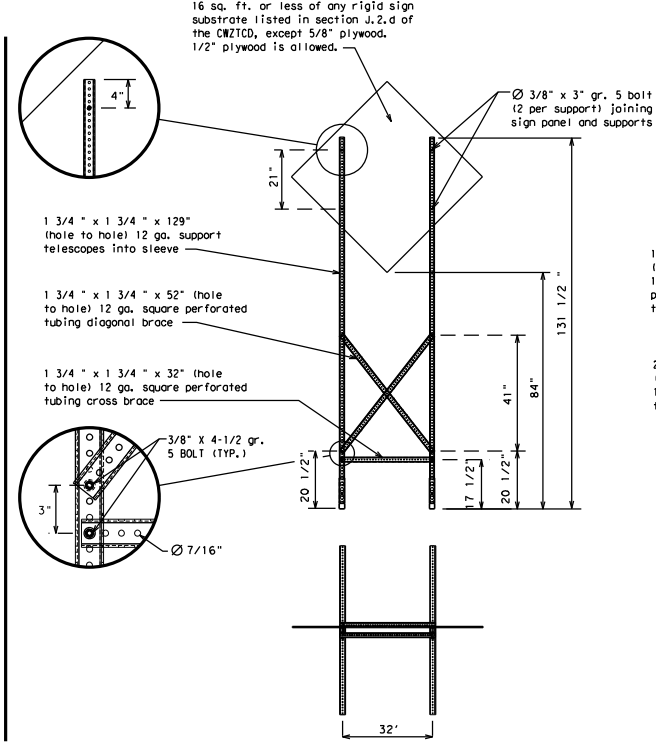

WEDGE ANCHORS

Both steel and plastic Wedge Anchor Systems as shown on the SMD Standard Sheets may be used as temporary sign supports for signs up to 10 square feet of sign face. They may be set in concrete or in sturdy soils if approved by the Engineer. (See web address for "Traffic Engineering Standard Sheets" on BC(1)).

OTHER DESIGNS

MORE DETAILS OF APPROVED LONG/INTERMEDIATE AND SHORT TERM SUPPORTS CAN BE FOUND ON THE CWZTCD LIST. SEE BC(1) FOR WEBSITE LOCATION.

GENERAL NOTES

1. Nails may be used in the assembly of wooden sign supports, but 3/8" bolts with nuts or 3/8" x 3 1/2" lag screws must be used on every joint for final connection.
 2. No more than 2 sign posts shall be placed within a 7 ft. circle, except for specific materials noted on the CWZTCD List.
 3. When project is completed, all sign supports and foundations shall be removed from the project site. This will be considered subsidiary to Item 502.
- * See BC(4) for definition of "Work Duration."
 ** Wood sign posts MUST be one piece. Splicing will NOT be allowed. Posts shall be painted white.
 See the CWZTCD for the type of sign substrate that can be used for each approved sign support.

SHEET 5 OF 12



BARRICADE AND CONSTRUCTION TYPICAL SIGN SUPPORT

BC(5) - 21

FILE:	bc-21.dgn	DN:	TxDOT	CR:	TxDOT	DR:	TxDOT	EX:	TxDOT
© TxDOT	November 2002	CONT	SECT	JOB	HIGHWAY				
9-07	8-14	6417	38	001	US 96, etc.				
7-13	5-21	DIST	COUNTY	SHEET NO.					
		LFK	San Augustine		10				

WHEN NOT IN USE, REMOVE THE PCMS FROM THE RIGHT-OF-WAY OR PLACE THE PCMS BEHIND BARRIER OR GUARDRAIL WITH SIGN PANEL TURNED PARALLEL TO TRAFFIC

PORTABLE CHANGEABLE MESSAGE SIGNS

- The Engineer/Inspector shall approve all messages used on portable changeable message signs (PCMS).
- Messages on PCMS shall contain no more than 8 words (about four to eight characters per word), not including simple words such as "TO," "FOR," "AT," etc.
- Messages should consist of a single phase, or two phases that alternate. Three-phase messages are not allowed. Each phase of the message should convey a single thought, and must be understood by itself.
- Use the word "EXIT" to refer to an exit ramp on a freeway; i.e., "EXIT CLOSED." Do not use the term "RAMP."
- Always use the route or interstate designation (IH, US, SH, FM) along with the number when referring to a roadway.
- When in use, the bottom of a stationary PCMS message panel should be a minimum 7 feet above the roadway, where possible. The message term "WEEKEND" should be used only if the work is to start on Saturday morning and end by Sunday evening at midnight. Actual days and hours of work should be displayed on the PCMS if work is to begin on Friday evening and/or continue into Monday morning.
- The Engineer/Inspector may select one of two options which are available for displaying a two-phase message on a PCMS. Each phase may be displayed for either four seconds each or for three seconds each. Do not "flash" messages or words included in a message. The message should be steady burn or continuous while displayed.
- Do not present redundant information on a two-phase message; i.e., keeping two lines of the message the same and changing the third line.
- Do not use the word "Danger" in message.
- Do not display the message "LANES SHIFT LEFT" or "LANES SHIFT RIGHT" on a PCMS. Drivers do not understand the message.
- Do not display messages that scroll horizontally or vertically across the face of the sign.
- The following table lists abbreviated words and two-word phrases that are acceptable for use on a PCMS. Both words in a phrase must be displayed together. Words or phrases not on this list should not be abbreviated, unless shown in the table.
- PCMS character height should be at least 18 inches for trailer mounted units. They should be visible from at least 1/2 (.5) mile and the text should be legible from at least 600 feet at night and 800 feet in daylight. Truck mounted units must have a character height of 10 inches and must be legible from at least 400 feet.
- Each line of text should be centered on the message board rather than left or right justified.
- If disabled, the PCMS should default to an illegible display that will not alarm motorists and will only be used to alert workers that the PCMS has malfunctioned. A pattern such as a series of horizontal solid bars is appropriate.

RECOMMENDED PHASES AND FORMATS FOR PCMS MESSAGES DURING ROADWORK ACTIVITIES
(The Engineer may approve other messages not specifically covered here.)

Phase 1: Condition Lists

Road/Lane/Ramp Closure List

FREEWAY CLOSED X MILE	FRONTAGE ROAD CLOSED
ROAD CLOSED AT SH XXX	SHOULDER CLOSED XXX FT
ROAD CLSD AT FM XXXX	RIGHT LN CLOSED XXX FT
RIGHT X LANES CLOSED	RIGHT X LANES OPEN
CENTER LANE CLOSED	DAYTIME LANE CLOSURES
NIGHT LANE CLOSURES	I-XX SOUTH EXIT CLOSED
VARIOUS LANES CLOSED	EXIT XXX CLOSED X MILE
EXIT CLOSED	RIGHT LN TO BE CLOSED
MALL DRIVEWAY CLOSED	X LANES CLOSED TUE - FRI
XXXXXXXX BLVD CLOSED	

Other Condition List

ROADWORK XXX FT	ROAD REPAIRS XXXX FT
FLAGGER XXXX FT	LANE NARROWS XXXX FT
RIGHT LN CLOSED XXXX FT	TWO-WAY TRAFFIC XX MILE
MERGING TRAFFIC XXXX FT	CONST TRAFFIC XXX FT
LOOSE GRAVEL XXXX FT	UNEVEN LANES XXXX FT
DETOUR X MILE	ROUGH ROAD XXXX FT
ROADWORK PAST SH XXXX	ROADWORK NEXT FRI-SUN
BUMP XXXX FT	US XXX EXIT X MILES
TRAFFIC SIGNAL XXXX FT	LANES SHIFT *

* LANES SHIFT in Phase 1 must be used with STAY IN LANE in Phase 2.

Phase 2: Possible Component Lists

Action to Take/Effect on Travel List

MERGE RIGHT	FORM X LINES RIGHT
DETOUR NEXT X EXITS	USE XXXXX RD EXIT
USE EXIT XXX	USE EXIT I-XX NORTH
STAY ON US XXX SOUTH	USE I-XX E TO I-XX N
TRUCKS USE US XXX N	WATCH FOR TRUCKS
WATCH FOR TRUCKS	EXPECT DELAYS
EXPECT DELAYS	PREPARE TO STOP
REDUCE SPEED XXX FT	END SHOULDER USE
USE OTHER ROUTES	WATCH FOR WORKERS
STAY IN LANE	*

Location List

AT FM XXXX
BEFORE RAILROAD CROSSING
NEXT X MILES
PAST US XXX EXIT
XXXXXXXXX TO XXXXXXX
US XXX TO FM XXXX

Warning List

SPEED LIMIT XX MPH
MAXIMUM SPEED XX MPH
MINIMUM SPEED XX MPH
ADVISORY SPEED XX MPH
RIGHT LANE EXIT
USE CAUTION
DRIVE SAFELY
DRIVE WITH CARE

**** Advance Notice List**

TUE-FRI XX AM - X PM
APR XX - X PM-X AM
BEGINS MONDAY
BEGINS MAY XX
MAY X-X XX PM - XX AM
NEXT FRI-SUN
XX AM TO XX PM
NEXT TUE AUG XX
TONIGHT XX PM - XX AM

** See Application Guidelines Note 6.

APPLICATION GUIDELINES

- Only 1 or 2 phases are to be used on a PCMS.
- The 1st phase (or both) should be selected from the "Road/Lane/Ramp Closure List" and the "Other Condition List".
- A 2nd phase can be selected from the "Action to Take/Effect on Travel, Location, General Warning, or Advance Notice Phase Lists".
- A Location Phase is necessary only if a distance or location is not included in the first phase selected.
- If two PCMS are used in sequence, they must be separated by a minimum of 1000 ft. Each PCMS shall be limited to two phases, and should be understandable by themselves.
- For advance notice, when the current date is within seven days of the actual work date, calendar days should be replaced with days of the week. Advance notification should typically be for no more than one week prior to the work.

WORDING ALTERNATIVES

- The words RIGHT, LEFT and ALL can be interchanged as appropriate.
- Roadway designations IH, US, SH, FM and LP can be interchanged as appropriate.
- EAST, WEST, NORTH and SOUTH (or abbreviations E, W, N and S) can be interchanged as appropriate.
- Highway names and numbers replaced as appropriate.
- ROAD, HIGHWAY and FREEWAY can be interchanged as needed.
- AHEAD may be used instead of distances if necessary.
- FT and MI, MILE and MILES interchanged as appropriate.
- AT, BEFORE and PAST interchanged as needed.
- Distances or AHEAD can be eliminated from the message if a location phase is used.

PCMS WITHIN THE R.O.W. SHALL BE BEHIND GUARDRAIL OR CONCRETE BARRIER OR SHALL HAVE A MINIMUM OF FOUR (4) PLASTIC DRUMS PLACED PERPENDICULAR TO TRAFFIC ON THE UPSTREAM SIDE OF THE PCMS, WHEN EXPOSED TO ONE DIRECTION OF TRAFFIC. WHEN EXPOSED TO TWO WAY TRAFFIC, THE FOUR DRUMS SHOULD BE PLACED WITH ONE DRUM AT EACH OF THE FOUR CORNERS OF THE UNIT.

FULL MATRIX PCMS SIGNS

- When Full Matrix PCMS signs are used, the character height and legibility/visibility requirements shall be maintained as listed in Note 15 under "PORTABLE CHANGEABLE MESSAGE SIGNS" above.
- When symbol signs, such as the "Flagger Symbol" (CW20-7) are represented graphically on the Full Matrix PCMS sign and, with the approval of the Engineer, it shall maintain the legibility/visibility requirement listed above.
- When symbol signs are represented graphically on the Full Matrix PCMS, they shall only supplement the use of the static sign represented, and shall not substitute for, or replace that sign.
- A full matrix PCMS may be used to simulate a flashing arrow board provided it meets the visibility, flash rate and dimming requirements on BC(7), for the same size arrow.

DISCLAIMER: The use of this standard is governed by the "Texas Engineering Practice Act". No warranty of any kind is made by the author for the use of this standard in any project. The author assumes no liability for any conversion of this standard to other formats or for any errors or omissions. This standard is the property of the author and is not to be reproduced without the author's written permission. Contact: 1-800-392-7233. Plans: 6417-38-001. San Augustine MFG. UDRS/STANDARD/TRAFFIC/BC(6)-21-THRU BC(12)-21-THRU. DATE: 11/17/2022 12:52:37 PM FILE: T:\NF\KDM\mnt\contracts\0-RMC - Routine Maintenance Contracts\1223 Plans\6417-38-001

WORD OR PHRASE	ABBREVIATION	WORD OR PHRASE	ABBREVIATION
Access Road	ACCS RD	Major	MAJ
Alternate	ALT	Miles	MI
Avenue	AVE	Miles Per Hour	MPH
Best Route	BEST RTE	Minor	MNR
Boulevard	BLVD	Monday	MON
Bridge	BRDG	Normal	NORM
Canal	CANT	North	N
Center	CTR	Northbound (route) N	
Construction Ahead	CONST AHD	Parking	PKING
CROSSING	XING	Road	RD
Detour Route	DETOUR RTE	Right Lane	RT LN
Do Not	DONT	Saturday	SAT
East	E	Service Road	SERV RD
Eastbound (route) E		Shoulder	SHLDR
Emergency	EMER	Slippery	SLIP
Emergency Vehicle	EMER VEH	South	S
Entrance, Enter	ENT	Southbound (route) S	
Express Lane	EXP LN	Speed	SPD
Expressway	EXPWY	Street	ST
XXXX Feet	XXXX FT	Sunday	SUN
Fog Ahead	FOG AHD	Telephone	PHONE
Freeway	FRWY, FWY	Temporary	TEMP
Freeway Blocked	FWY BLKD	Thursday	THURS
Friday	FRI	To Downtown	TO DOWNTN
Hazardous Driving	HAZ DRIVING	Traffic	TRAF
Hazardous Material	HAZMAT	Travelers	TRVLRS
High Occupancy	HOV	Tuesday	TUES
Vehicle Highway	HWY	Time Minutes	TIME MIN
Hour(s)	HR, HRS	Upper Level	UPPER LEVEL
Information	INFO	Westbound (route) W	
ITS	ITS	Westbound	WEST
Junction	JCT	Wet Pavement	WET PVMT
Left	LFT	Will Not	WONT
Left Lane	LFT LN		
Lane Closed	LN CLOSED		
Lower Level	LR LEVEL		
Maintenance	MAINT		

Roadway designation = IH-number, US-number, SH-number, FM-number

<p>BARRICADE AND CONSTRUCTION PORTABLE CHANGEABLE MESSAGE SIGN (PCMS)</p> <p>BC (6) - 21</p>			
FILE#	DC-21.dgn	DN#	TxDOT
REV#	November 2002	CR#	TxDOT
CON#	6417	DN#	TxDOT
SECT#	38	CR#	TxDOT
JOB#	001	DN#	TxDOT
US 96, etc.		CR#	TxDOT
DIST	9-07	DN#	TxDOT
COUNTY	8-14	CR#	TxDOT
SHEET NO.	7-13	DN#	TxDOT
	5-21	CR#	TxDOT
	LFK	DN#	TxDOT
	San Augustine	CR#	TxDOT

DISCLAIMER: This standard is approved by the Texas Engineering, Precast, Inc. No warranty, of any kind is made by TxDOT for any purpose whatsoever. TxDOT assumes no responsibility for the conversion of this standard to other formats or for incorrect results or damages resulting from its use.

DATE: 11/17/2022 12:52:38 PM
 FILE: T:\NF\KDM\mnt\contracts\0-RMC - Routine Maintenance Contracts\123 Plans\6417-38-001 San Augustine MBRF\DONN\STANDARD\TRAFFIC\BC(7)-21 THRU BC(12)-21.dgn

- Barrier Reflectors shall be pre-qualified, and conform to the color and reflectivity requirements of DMS-8600. A list of prequalified Barrier Reflectors can be found at the Material Producer List web address shown on BC(1).
- Color of Barrier Reflectors shall be as specified in the TMUTCD. The cost of the reflectors shall be considered subsidiary to Item 512.

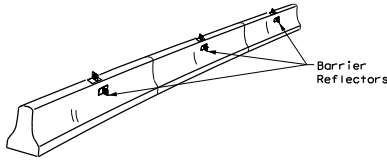

CONCRETE TRAFFIC BARRIER (CTB)

- Where traffic is on one side of the CTB, two (2) Barrier Reflectors shall be mounted in approximately the midsection of each section of CTB. An alternate mounting location is uniformly spaced at one end of each CTB. This will allow for attachment of a barrier grapple without damaging the reflector. The Barrier Reflector mounted on the side of the CTB shall be located directly below the reflector mounted on top of the barrier, as shown in the detail above.
- Where CTB separates two-way traffic, three barrier reflectors shall be mounted on each section of CTB. The reflector unit on top shall have two yellow reflective faces (Bi-Directional) while the reflectors on each side of the barrier shall have one yellow reflective face, as shown in the detail above.
- When CTB separates traffic traveling in the same direction, no barrier reflectors will be required on top of the CTB.
- Barrier Reflector units shall be yellow or white in color to match the edgeline being supplemented.
- Maximum spacing of Barrier Reflectors is forty (40) feet.
- Pavement markers or temporary flexible-reflective roadway marker tabs shall NOT be used as CTB delineation.
- Attachment of Barrier Reflectors to CTB shall be per manufacturer's recommendations.
- Missing or damaged Barrier Reflectors shall be replaced as directed by the Engineer.
- Single slope barriers shall be delineated as shown on the above detail.

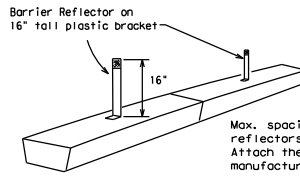

LOW PROFILE CONCRETE BARRIER (LPCB)

LOW PROFILE CONCRETE BARRIER (LPCB) USED IN WORK ZONES

LPCB is approved for use in work zone locations, where the posted speed is 45mph, or less. See Roadway Standard Sheet LPCB.

Max. spacing of barrier reflectors is 20 feet. Attach the delineators as per manufacturer's recommendations.

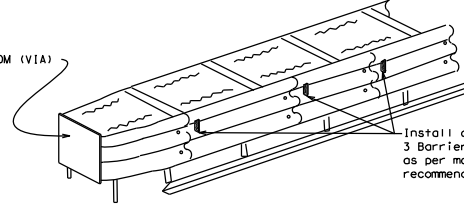

DELINEATION OF END TREATMENTS

END TREATMENTS FOR CTB'S USED IN WORK ZONES

End treatments used on CTB's in work zones shall meet the appropriate crashworthy standards as defined in the Manual for Assessing Safety Hardware (MASH). Refer to the CWZTC List for approved end treatments and manufacturers.

BARRIER REFLECTORS FOR CONCRETE TRAFFIC BARRIER AND ATTENUATORS

WARNING LIGHTS

- Warning lights shall meet the requirements of the TMUTCD.
- Warning lights shall NOT be installed on barricades.
- Type A-Low Intensity Flashing Warning Lights are commonly used with drums. They are intended to warn or mark a potentially hazardous area. Their use shall be as indicated on this sheet and/or other sheets of the plans by the designation "FL". The Type A Warning Lights shall not be used with signs manufactured with Type B₁₀ or C₁₀ Sheeting meeting the requirements of Departmental Material Specification DMS-8300.
- Type-C and Type D 360 degree Steady Burn Lights are intended to be used in a series for delineation to supplement other traffic control devices. Their use shall be as indicated on this sheet and/or other sheets of the plans by the designation "SB".
- The Engineer/Inspector or the plans shall specify the location and type of warning lights to be installed on the traffic control devices.
- When required by the Engineer, the Contractor shall furnish a copy of the warning lights certification. The warning light manufacturer will certify the warning lights meet the requirements of the latest ITE Purchase Specifications for Flashing and Steady-Burn Warning Lights.
- When used to delineate curves, Type-C and Type D Steady Burn Lights should only be placed on the outside of the curve, not the inside.
- The location of warning lights and warning reflectors on drums shall be as shown elsewhere in the plans.

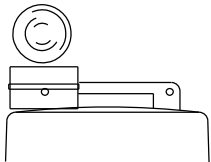

Type C Warning Light or approved substitute mounted on a drum adjacent to the travel way.

WARNING LIGHTS MOUNTED ON PLASTIC DRUMS

- Type A flashing warning lights are intended to warn drivers that they are approaching or are in a potentially hazardous area.
- Type A random flashing warning lights are not intended for delineation and shall not be used in a series.
- A series of sequential flashing warning lights placed on channelizing devices to form a merging taper may be used for delineation. If used, the successive flashing of the sequential warning lights should occur from the beginning of the taper to the end of the merging taper in order to identify the desired vehicle path. The rate of flashing for each light shall be 65 flashes per minute, plus or minus 10 flashes.
- Type C and D steady-burn warning lights are intended to be used in a series to delineate the edge of the travel lane on detours, on lane changes, on lane closures, and on other similar conditions.
- Type A, Type C and Type D warning lights shall be installed at locations as detailed on other sheets in the plans.
- Warning lights shall not be installed on a drum that has a sign, chevron or vertical panel.
- The maximum spacing for warning lights on drums should be identical to the channelizing device spacing.

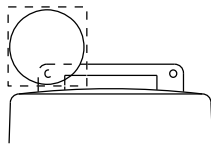

Warning reflector may be round or square. Must have a yellow reflective surface area of at least 30 square inches

WARNING REFLECTORS MOUNTED ON PLASTIC DRUMS AS A SUBSTITUTE FOR TYPE C (STEADY BURN) WARNING LIGHTS

- A warning reflector or approved substitute may be mounted on a plastic drum as a substitute for a Type C, steady burn warning light at the discretion of the Contractor unless otherwise noted in the plans.
- The warning reflector shall be yellow in color and shall be manufactured using a sign substrate approved for use with plastic drums listed on the CWZTC.
- The warning reflector shall have a minimum retroreflective surface area (one-side) of 30 square inches.
- Round reflectors shall be fully reflectorized, including the area where attached to the drum.
- Square substrates must have a minimum of 30 square inches of reflectorized sheeting. They do not have to be reflectorized where it attaches to the drum.
- The side of the warning reflector facing approaching traffic shall have sheeting meeting the color and retroreflectivity requirements for DMS 8300-Type B or Type C.
- When used near two-way traffic, both sides of the warning reflector shall be reflectorized.
- The warning reflector should be mounted on the side of the handle nearest approaching traffic.
- The maximum spacing for warning reflectors should be identical to the channelizing device spacing requirements.

Arrow Boards may be located behind channelizing devices in place for a shoulder taper or merging taper, otherwise they shall be delineated with four (4) channelizing devices placed perpendicular to traffic on the upstream side of traffic.

- The Flashing Arrow Board should be used for all lane closures on multi-lane roadways, or slow moving maintenance or construction activities on the travel lanes.
- Flashing Arrow Boards should not be used on two-lane, two-way roadways, detours, diversions or work on shoulders unless the "CAUTION" display (see detail below) is used.
- The Engineer/Inspector shall choose all appropriate signs, barricades and/or other traffic control devices that should be used in conjunction with the Flashing Arrow Board.
- The Flashing Arrow Board should be able to display the following symbols:

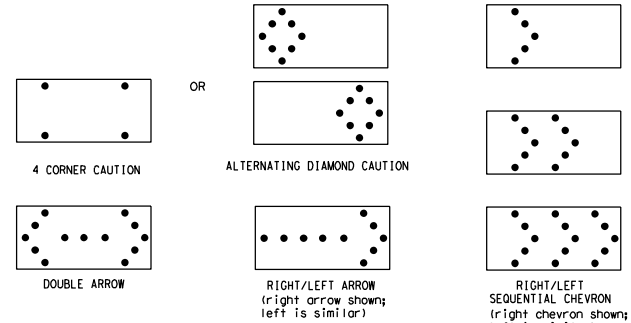

- The "CAUTION" display consists of four corner lamps flashing simultaneously, or the Alternating Diamond Caution mode as shown.
- The straight line caution display is NOT ALLOWED.
- The Flashing Arrow Board shall be capable of minimum 50 percent dimming from rated lamp voltage.
- The flashing rate of the lamps shall not be less than 25 nor more than 40 flashes per minute.
- Minimum lamp "on time" shall be approximately 50 percent for the flashing arrow and equal intervals of 25 percent for each sequential phase of the flashing chevron.
- The sequential arrow display is NOT ALLOWED.
- The flashing arrow display is the TxDOT standard; however, the sequential chevron display may be used during daylight operations.
- The Flashing Arrow Board shall be mounted on a vehicle, trailer or other suitable support.
- A Flashing Arrow Board SHALL NOT BE USED to laterally shift traffic.
- A full matrix PMS may be used to simulate a Flashing Arrow Board provided it meets visibility, flash rate and dimming requirements on this sheet for the same size arrow.
- Minimum mounting height of trailer mounted Arrow Boards should be 7 feet from roadway to bottom of panel.

REQUIREMENTS			
TYPE	MINIMUM SIZE	MINIMUM NUMBER OF PANEL LAMPS	MINIMUM VISIBILITY DISTANCE
A	30 x 60	13	3/4 mile
B	48 x 96	15	1 mile

ATTENTION
Flashing Arrow Boards shall be equipped with automatic dimming devices.

WHEN NOT IN USE, REMOVE THE ARROW BOARD FROM THE RIGHT-OF-WAY OR PLACE THE ARROW BOARD BEHIND CONCRETE TRAFFIC BARRIER OR GUARDRAIL.

FLASHING ARROW BOARDS

SHEET 7 OF 12

TRUCK-MOUNTED ATTENUATORS

- Truck-mounted attenuators (TMA) used on TxDOT facilities must meet the requirements outlined in the Manual for Assessing Safety Hardware (MASH).
- Refer to the CWZTC for the requirements of Level 2 or Level 3 TMAs.
- Refer to the CWZTC for a list of approved TMAs.
- TMAs are required on freeways unless otherwise noted in the plans.
- A TMA should be used anytime that it can be positioned 30 to 100 feet in advance of the area of crew exposure without adversely affecting the work performance.
- The only reason a TMA should not be required is when a work area is spread down the roadway and the work crew is an extended distance from the TMA.

Texas Department of Transportation
Traffic Safety Division Standard

BARRICADE AND CONSTRUCTION
ARROW PANEL, REFLECTORS,
WARNING LIGHTS & ATTENUATOR

BC (7) - 21

FILE: bc-21.dgn	DN: TxDOT	CR: TxDOT	DR: TxDOT	EX: TxDOT
REVISED: November 2002	CONT: 6417	SECT: 38	JOB: 001	HIGHWAY: US 96, etc.
9-07	B-14	DIST:	COUNTY:	SHEET NO.:
7-13	5-21	LFK	San Augustine	12

DISCLAIMER: This standard is governed by the "Texas Engineering Practice Act". No warranty of any kind is made by TxDOT for any purpose whatsoever. TxDOT assumes no responsibility for the conversion of this standard to other formats or for incorrect results or damages resulting from its use.

DATE: 11/17/2022 12:52:38 PM
 FILE: T:\NF\KDM\Main\Contr\contracts\0-RMC - Routine Maintenance Contracts\123 Plans\6417-38-001 San Augustine MBR\DDN\STANDARD\TRAFFIC\BC(8)-21 THRU BC(12)-21.dgn

GENERAL NOTES

- For long term stationary work zones on freeways, drums shall be used as the primary channelizing device.
- For intermediate term stationary work zones on freeways, drums should be used as the primary channelizing device but may be replaced in tangent sections by vertical panels, or 42" two-piece cones. In tangent sections, one-piece cones may be used with the approval of the Engineer but only if personnel are present on the project at all times to maintain the cones in proper position and location.
- For short term stationary work zones on freeways, drums are the preferred channelizing device but may be replaced in tapers, transitions and tangent sections by vertical panels, two-piece cones or one-piece cones as approved by the Engineer.
- Drums and all related items shall comply with the requirements of the current version of the "Texas Manual on Uniform Traffic Control Devices" (TMUTCD) and the "Compliant Work Zone Traffic Control Devices List" (CWZTCD).
- Drums, bases, and related materials shall exhibit good workmanship and shall be free from objectionable marks or defects that would adversely affect their appearance or serviceability.
- The Contractor shall have a maximum of 24 hours to replace any plastic drums identified for replacement by the Engineer/Inspector. The replacement device must be an approved device.

GENERAL DESIGN REQUIREMENTS

Pre-qualified plastic drums shall meet the following requirements:

- Plastic drums shall be a two-piece design; the "body" of the drum shall be the top portion and the "base" shall be the bottom.
- The body and base shall "lock" together in such a manner that the body separates from the base when impacted by a vehicle traveling at a speed of 20 MPH or greater but prevents accidental separation due to normal handling and/or air turbulence created by passing vehicles.
- Plastic drums shall be constructed of lightweight flexible, and deformable materials. The Contractor shall NOT use metal drums or single piece plastic drums as channelization devices or sign supports.
- Drums shall present a profile that is a minimum of 18 inches in width at the 36 inch height when viewed from any direction. The height of drum unit (body installed on base) shall be a minimum of 36 inches and a maximum of 42 inches.
- The top of the drum shall have a built-in handle for easy pickup and shall be designed to drain water and not collect debris. The handle shall have a minimum of two widely spaced 9/16 inch diameter holes to allow attachment of a warning light, warning reflector unit or approved compliant sign.
- The exterior of the drum body shall have a minimum of four alternating orange and white retroreflective circumferential stripes not less than 4 inches nor greater than 8 inches in width. Any non-reflectorized space between any two adjacent stripes shall not exceed 2 inches in width.
- Bases shall have a maximum width of 36 inches, a maximum height of 4 inches, and a minimum of two footholds of sufficient size to allow base to be held down while separating the drum body from the base.
- Plastic drums shall be constructed of ultra-violet stabilized, orange, high-density polyethylene (HDPE) or other approved material.
- Drum body shall have a maximum unballasted weight of 11 lbs.
- Drum and base shall be marked with manufacturer's name and model number.

RETROREFLECTIVE SHEETING

- The stripes used on drums shall be constructed of sheeting meeting the color and retroreflectivity requirements of Departmental Materials Specification DMS-8300, "Sign Face Materials." Type A or Type B reflective sheeting shall be supplied unless otherwise specified in the plans.
- The sheeting shall be suitable for use on and shall adhere to the drum surface such that, upon vehicular impact, the sheeting shall remain adhered in-place and exhibit no delaminating, cracking, or loss of retroreflectivity other than that loss due to abrasion of the sheeting surface.

BALLAST

- Unballasted bases shall be large enough to hold up to 50 lbs. of sand. This base, when filled with the ballast material, should weigh between 35 lbs (minimum) and 50 lbs (maximum). The ballast may be sand in one to three sandbags separate from the base, sand in a sand-filled plastic base, or other ballasting devices as approved by the Engineer. Stacking of sandbags will be allowed, however height of sandbags above pavement surface may not exceed 12 inches.
- Bases with built-in ballast shall weigh between 40 lbs. and 50 lbs. Built-in ballast can be constructed of an integral crumb rubber base or a solid rubber base.
- Recycled truck tire sidewalls may be used for ballast on drums approved for this type of ballast on the CWZTCD list.
- The ballast shall not be heavy objects, water, or any material that would become hazardous to motorists, pedestrians, or workers when the drum is struck by a vehicle.
- When used in regions susceptible to freezing, drums shall have drainage holes in the bottoms so that water will not collect and freeze becoming a hazard when struck by a vehicle.
- Ballast shall not be placed on top of drums.
- Adhesives may be used to secure base of drums to pavement.

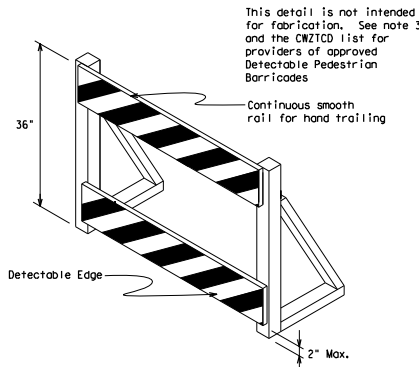
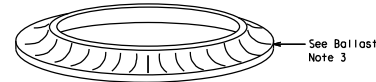
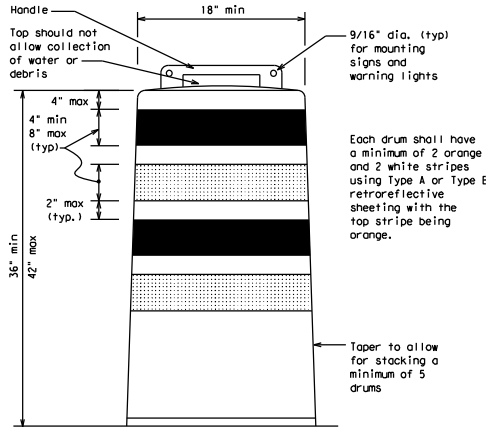

DETECTABLE PEDESTRIAN BARRICADES

- When existing pedestrian facilities are disrupted, closed, or relocated in a TTC zone, the temporary facilities shall be detectable and include accessibility features consistent with the features present in the existing pedestrian facility. Refer to M2(BTS-2) for Pedestrian Control requirements for Sidewalk Diversions, Sidewalk Detours and Crosswalk Closures.
- Where pedestrians with visual disabilities normally use the closed sidewalk, a Detectable Pedestrian Barricade shall be placed across the full width of the closed sidewalk instead of a Type 3 Barricade.
- Detectable pedestrian barricades similar to the one pictured above, longitudinal channelizing devices, some concrete barriers, and wood or chain link fencing with a continuous detectable edging can satisfactorily delineate a pedestrian path.
- Tape, rope, or plastic chain strung between devices are not detectable, do not comply with the design standards in the "Americans with Disabilities Act Accessibility Guidelines (ADAAG)" and should not be used as a control for pedestrian movements.
- Warning lights shall not be attached to detectable pedestrian barricades.
- Detectable pedestrian barricades should use 8" nominal barricade rolls as shown on BC(10) provided that the top roll provides a smooth continuous roll suitable for hand trailing with no splinters, burrs, or sharp edges.

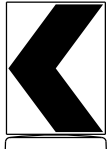

18" x 24" Sign
(Maximum Sign Dimension)
Chevron CW1-8, Opposing Traffic Lane Divider, Driveway sign D70a, Keep Right R4 series or other signs as approved by Engineer

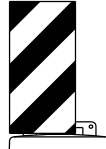

12" x 24" Vertical Panel
mount with diagonals sloping down towards travel way

Plywood, Aluminum or Metal sign substrates shall NOT be used on plastic drums

SIGNS, CHEVRONS, AND VERTICAL PANELS MOUNTED ON PLASTIC DRUMS

- Signs used on plastic drums shall be manufactured using substrates listed on the CWZTCD.
- Chevrons and other work zone signs with an orange background shall be manufactured with Type B_{FL} or Type C_{FL} Orange sheeting meeting the color and retroreflectivity requirements of DMS-8300, "Sign Face Material," unless otherwise specified in the plans.
- Vertical Panels shall be manufactured with orange and white sheeting meeting the requirements of DMS-8300 Type A or Type B. Diagonal stripes on Vertical Panels shall slope down toward the intended traveled lane.
- Other sign messages (text or symbolic) may be used as approved by the Engineer. Sign dimensions shall not exceed 18 inches in width or 24 inches in height, except for the R9 series signs discussed in note 8 below.
- Signs shall be installed using a 1/2 inch bolt (nominal) and nut, two washers, and one locking washer for each connection.
- Mounting bolts and nuts shall be fully engaged and adequately torqued. Bolts should not extend more than 1/2 inch beyond nuts.
- Chevrons may be placed on drums on the outside of curves, on merging tapers or on shifting tapers. When used in these locations, they may be placed on every drum or spaced not more than on every third drum. A minimum of three (3) should be used at each location called for in the plans.
- R9-9, R9-10, R9-11 and R9-11a Sidewalk Closed signs which are 24 inches wide may be mounted on plastic drums, with approval of the Engineer.

SHEET 8 OF 12



Texas Department of Transportation

Traffic Safety Division Standard

BARRICADE AND CONSTRUCTION CHANNELIZING DEVICES

BC (8) - 21

FILE: bc-21.dgn	DN: TxDOT	CR: TxDOT	DR: TxDOT	EX: TxDOT
REV: November 2002	CONF	SECT	JOB	HIGHWAY
4-03 8-14	6417	38	001	US 96, etc.
9-07 5-21	DIST	COUNTY		SHEET NO.
7-13	LFK	San Augustine		13

DISCLAIMER: This drawing is governed by the "Texas Engineering Practice Act". No warranty of any kind is made by TxDOT for use of this drawing for any purpose other than that for which it was prepared. The user assumes all liability for any and all consequences or damages resulting from its use.

DATE: 11/17/2022 12:52:39 PM
 FILE: T:\LKFDMA\Main\Contracts\0-RMC - Routine Maintenance Contracts\123 Plans\6417-38-001 San Augustine MBR-DOWNSTANDARD-TRAFF-BC(11)-21 THRU BC(12)-21.dgn

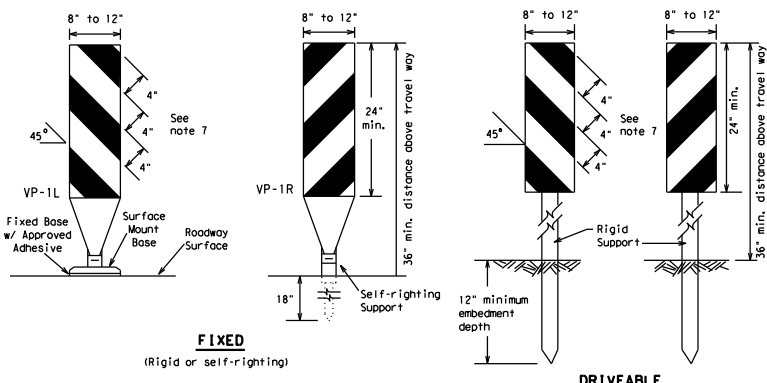

FIXED
(Rigid or self-righting)

DRIVEABLE

- Vertical Panels (VP's) are normally used to channelize traffic or divide opposing lanes of traffic.
- VP's may be used in daytime or nighttime situations. They may be used at the edge of shoulder drop-offs and other areas such as lane transitions where positive daytime and nighttime delineation is required. The Engineer/Inspector shall refer to the Roadway Design Manual for additional requirements on the use of VP's for drop-offs.
- VP's should be mounted back to back if used at the edge of cuts adjacent to two-way two lane roadways. Stripes are to be reflective orange and reflective white and should always slope downward toward the travel lane.
- VP's used on expressways and freeways or other high speed roadways, may have more than 270 square inches of retroreflective area facing traffic.
- Self-righting supports are available with portable base. See "Compliant Work Zone Traffic Control Devices List" (CWZTCD).
- Sheeting for the VP's shall be retroreflective Type A or Type B conforming to Departmental Material Specification DMS-8300, unless noted otherwise.
- Where the height of reflective material on the vertical panel is 36 inches or greater, a panel stripe of 6 inches shall be used.

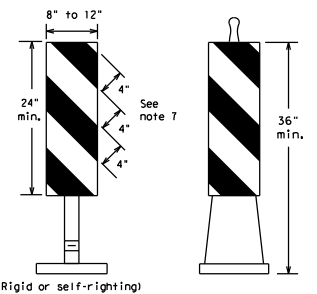

PORTABLE
(Rigid or self-righting)

VERTICAL PANELS (VPs)

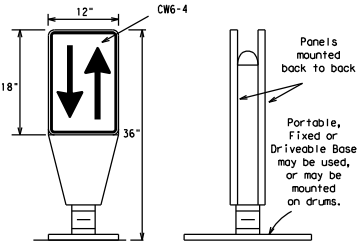

OPPOSING TRAFFIC LANE DIVIDERS (OTLD)

- Opposing Traffic Lane Dividers (OTLD) are delineation devices designed to convert a normal one-way roadway section to two-way operation. OTLD's are used on temporary centerlines. The upward and downward arrows on the sign's face indicate the direction of traffic on either side of the divider. The base is secured to the pavement with an adhesive or rubber weight to minimize movement caused by a vehicle impact or wind gust.
- The OTLD may be used in combination with 42" cones or VPs.
- Spacing between the OTLD shall not exceed 500 feet. 42" cones or VPs placed between the OTLD's should not exceed 100 foot spacing.
- The OTLD shall be orange with a black non-reflective legend. Sheeting for the OTLD shall be retroreflective Type B₁ or Type C₁ conforming to Departmental Material Specification DMS-8300, unless noted otherwise. The legend shall meet the requirements of DMS-8300.

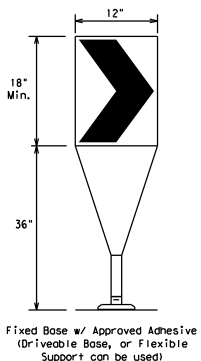

Fixed Base w/ Approved Adhesive (Driveable Base, or Flexible Support can be used)

- The chevron shall be a vertical rectangle with a minimum size of 12 by 18 inches.
- Chevrons are intended to give notice of a sharp change of alignment with the direction of travel and provide additional emphasis and guidance for vehicle operators with regard to changes in horizontal alignment of the roadway.
- Chevrons, when used, shall be erected on the outside of a sharp curve or turn, or on the far side of an intersection. They shall be in line with and at right angles to approaching traffic. Spacing should be such that the motorist always has three in view, until the change in alignment eliminates its need.
- To be effective, the chevron should be visible for at least 500 feet.
- Chevrons shall be orange with a black nonreflective legend. Sheeting for the chevron shall be retroreflective Type B₁ or Type C₁ conforming to Departmental Material Specification DMS-8300, unless noted otherwise. The legend shall meet the requirements of DMS-8300.
- For Long Term Stationary use on tapers or transitions on freeways and divided highways, self-righting chevrons may be used to supplement plastic drums but not to replace plastic drums.

CHEVRONS

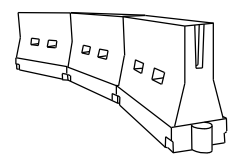

LONGITUDINAL CHANNELIZING DEVICES (LCD)

- LCDs are crashworthy, lightweight, deformable devices that are highly visible, have good target value and can be connected together. They are not designed to contain or redirect a vehicle on impact.
- LCDs may be used instead of a line of cones or drums.
- LCDs shall be placed in accordance to application and installation requirements specific to the device, and used only when shown on the CWZTCD list.
- LCDs should not be used to provide positive protection for obstacles, pedestrians or workers.
- LCDs shall be supplemented with retroreflective delineation as required for temporary barriers on BC(7) when placed roughly parallel to the travel lanes.
- LCDs used as barricades perpendicular to traffic should have at least one row of reflective sheeting meeting the requirements for barricade rails as shown on BC(10). Place reflective sheeting near the top of the LCD along the full length of the device.

WATER BALLASTED SYSTEMS USED AS BARRIERS

- Water ballasted systems used as barriers shall not be used solely to channelize road users, but also to protect the work space per the appropriate Manual for Assessing Safety Hardware (MASH) crashworthiness requirements based on roadway speed and barrier application.
- Water ballasted systems used to channelize vehicular traffic shall be supplemented with retroreflective delineation or channelizing devices to improve daytime/nighttime visibility. They may also be supplemented with pavement markings.
- Water ballasted systems used as barriers shall be placed in accordance to application and installation requirements specific to the device, and used only when shown on the CWZTCD list.
- Water ballasted systems used as barriers should not be used for a merging taper except in low speed (less than 45 MPH) urban areas. When used on a taper in a low speed urban area, the taper shall be delineated and the taper length should be designed to optimize road user operations considering the available geometric conditions.
- When water ballasted systems used as barriers have blunt ends exposed to traffic, they should be attenuated as per manufacturer recommendations or flared to a point outside the clear zone.

If used to channelize pedestrians, longitudinal channelizing devices or water ballasted systems must have a continuous detectable bottom for users of long cones and the top of the unit shall not be less than 32 inches in height.

HOLLOW OR WATER BALLASTED SYSTEMS USED AS LONGITUDINAL CHANNELIZING DEVICES OR BARRIERS

GENERAL NOTES

- Work Zone channelizing devices illustrated on this sheet may be installed in close proximity to traffic and are suitable for use on high or low speed roadways. The Engineer/Inspector shall ensure that spacing and placement is uniform and in accordance with the "Texas Manual on Uniform Traffic Control Devices" (TMUTCD).
- Channelizing devices shown on this sheet may have a driveable, fixed or portable base. The requirement for self-righting channelizing devices must be specified in the General Notes or other plan sheets.
- Channelizing devices on self-righting supports should be used in work zone areas where channelizing devices are frequently impacted by errant vehicles or vehicle related wind gusts making alignment of the channelizing devices difficult to maintain. Locations of these devices shall be detailed elsewhere in the plans. These devices shall conform to the TMUTCD and the "Compliant Work Zone Traffic Control Devices List" (CWZTCD).
- The Contractor shall maintain devices in a clean condition and replace damaged, nonreflective, faded, or broken devices and bases as required by the Engineer/Inspector. The Contractor shall be required to maintain proper device spacing and alignment.
- Portable bases shall be fabricated from virgin and/or recycled rubber. The portable bases shall weigh a minimum of 30 lbs.
- Pavement surfaces shall be prepared in a manner that ensures proper bonding between the adhesives, the fixed mount bases and the pavement surface. Adhesives shall be prepared and applied according to the manufacturer's recommendations.
- The installation and removal of channelizing devices shall not cause detrimental effects to the final pavement surfaces, including pavement surface discoloration or surface integrity. Driveable bases shall not be permitted on final pavement surfaces. The Engineer/Inspector shall approve all application and removal procedures of fixed bases.

Posted Speed	Formula	Minimum Desirable Taper Lengths **			Suggested Maximum Spacing of Channelizing Devices	
		10' Offset	11' Offset	12' Offset	On a Taper	On a Tangent
30	L = WS / 60	150'	165'	180'	30'	60'
35		205'	225'	245'	35'	70'
40	L = WS	265'	295'	320'	40'	80'
45		450'	495'	540'	45'	90'
50	L = WS	500'	550'	600'	50'	100'
55		550'	605'	660'	55'	110'
60	L = WS	600'	660'	720'	60'	120'
65		650'	715'	780'	65'	130'
70	L = WS	700'	770'	840'	70'	140'
75		750'	825'	900'	75'	150'
80	L = WS	800'	880'	960'	80'	160'
85		850'	945'	1020'	85'	170'

** Taper lengths have been rounded off.
 L=Length of Taper (FT.) W=Width of Offset (FT.)
 S=Posted Speed (MPH)

SUGGESTED MAXIMUM SPACING OF CHANNELIZING DEVICES AND MINIMUM DESIRABLE TAPER LENGTHS

SHEET 9 OF 12



BARRICADE AND CONSTRUCTION CHANNELIZING DEVICES

BC (9) - 21

FILE:	dc-21.dgn	DATE:	TxDOT	DATE:	TxDOT	DATE:	TxDOT
REVISED:	6417	38	001	US	96	etc.	
DATE:	9-07	8-1					
DATE:	7-13	5-21	LFK	San	Augustine	14	

DISCLAIMER: The use of this standard is governed by the "Texas Engineering Practice Act". No warranty of any kind is made by the use of this standard to other formats or for incorrect results or damages resulting from its use. This standard is subject to change without notice. For more information, contact the Texas Department of Transportation, 1701 Ross Avenue, Austin, Texas 78761-1399.

DATE: 11/17/2022 12:52:39 PM
 FILE: T:\LKFD\MAINT\Contractors\0_RMC - Routine Maintenance Contracts\1723 Plans\6417-38-001 San Augustine M&F\DOCS\STANDARD\TRAFFIC\BC(10)-21 THRU BC(12)-21.dgn

TYPE 3 BARRICADES

1. Refer to the Compliant Work Zone Traffic Control Devices List (CWZTD) for details of the Type 3 Barricades and a list of all materials used in the construction of Type 3 Barricades.
2. Type 3 Barricades shall be used at each end of construction projects closed to all traffic.
3. Barricades extending across a roadway should have stripes that slope downward in the direction toward which traffic must turn in detouring. When both right and left turns are provided, the chevron striping may slope downward in both directions from the center of the barricade. Where no turns are provided at a closed road, striping should slope downward in both directions toward the center of roadway.
4. Striping of rails, for the right side of the roadway, should slope downward to the left. For the left side of the roadway, striping should slope downward to the right.
5. Identification markings may be shown only on the back of the barricade rails. The maximum height of letters and/or company logos used for identification shall be 1".
6. Barricades shall not be placed parallel to traffic unless an adequate clear zone is provided.
7. Warning lights shall NOT be installed on barricades.
8. Where barricades require the use of weights to keep from turning over, the use of sandbags with dry, cohesionless sand is recommended. The sandbags will be tied shut to keep the sand from spilling and to maintain a constant weight. Sand bags shall not be stacked in a manner that covers any portion of a barricade rails reflective sheeting. Rock, concrete, iron, steel or other solid objects will NOT be permitted. Sandbags should weigh a minimum of 35 lbs and a maximum of 50 lbs. Sandbags shall be made of a durable material that tears upon vehicular impact. Rubber (such as fire inner tubes) shall not be used for sandbags. Sandbags shall only be placed along or upon the base supports of the device and shall not be suspended above ground level or hung with rope, wire, chains or other fasteners.
9. Sheeting for barricades shall be retroreflective Type A or Type B conforming to Departmental Material Specification DMS-8300 unless otherwise noted.

Barricades shall NOT be used as a sign support.

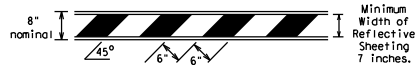

TYPICAL STRIPING DETAIL FOR BARRICADE RAIL

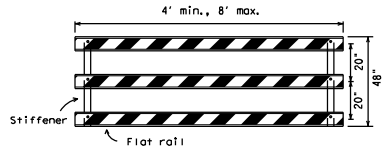

Stiffener may be inside or outside of support, but no more than 2 stiffeners shall be allowed on one barricade.

TYPICAL PANEL DETAIL FOR SKID OR POST TYPE BARRICADES

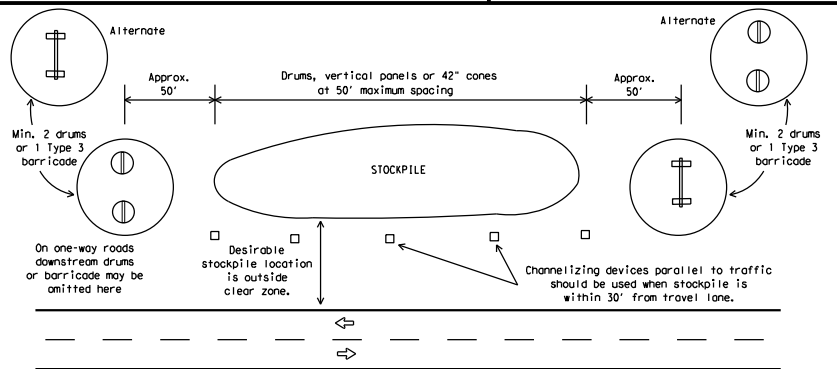

TRAFFIC CONTROL FOR MATERIAL STOCKPILES

Each roadway of a divided highway shall be barricaded in the same manner.

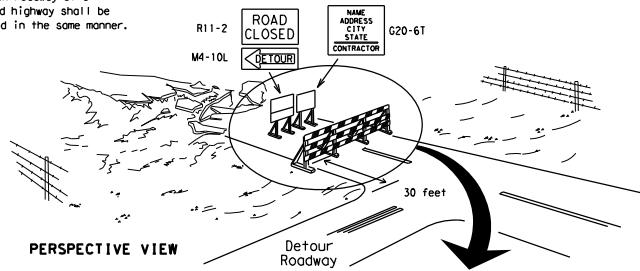

PERSPECTIVE VIEW

The three rails on Type 3 barricades shall be reflectorized orange and reflective white stripes on one side facing one-way traffic and both sides for two-way traffic. Barricade striping should slant downward in the direction of detour.

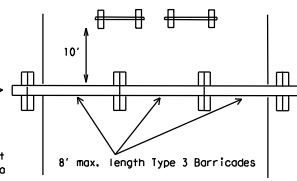

PLAN VIEW

1. Signs should be mounted on independent supports at a 7 foot mounting height in center of roadway. The signs should be a minimum of 10 feet behind Type 3 Barricades.
2. Advance signing shall be as specified elsewhere in the plans.

TYPE 3 BARRICADE (POST AND SKID) TYPICAL APPLICATION

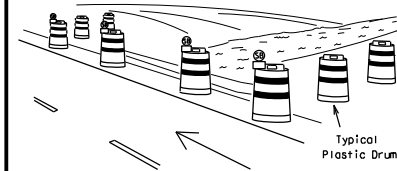

PERSPECTIVE VIEW

These drums are not required on one-way roadway

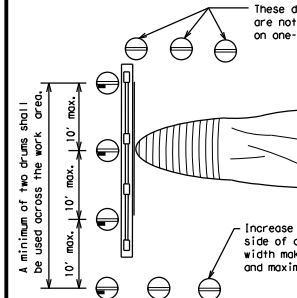

PLAN VIEW

Increase number of plastic drums on the side of approaching traffic if the crown width makes it necessary. (minimum of 2 and maximum of 4 drums)

1. Where positive redirection capability is provided, drums may be omitted.
2. Plastic construction fencing may be used with drums for safety as required in the plans.
3. Vertical Panels on flexible support may be substituted for drums when the shoulder width is less than 4 feet.
4. When the shoulder width is greater than 12 feet, steady-burn lights may be omitted if drums are used.
5. Drums must extend the length of the culvert widening.

LEGEND

	Plastic drum
	Plastic drum with steady burn light or yellow warning reflector
	Steady burn warning light or yellow warning reflector

CULVERT WIDENING OR OTHER ISOLATED WORK WITHIN THE PROJECT LIMITS

CONES

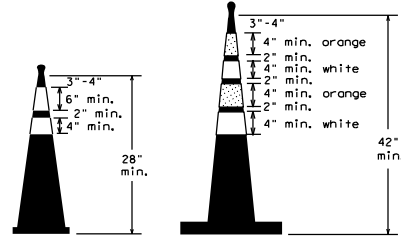

Two-Piece cones

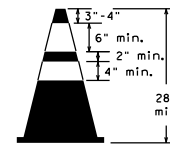

One-Piece cones

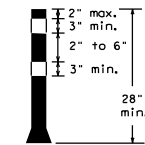

Tubular Marker

28" Cones shall have a minimum weight of 9 1/2 lbs.

42" 2-piece cones shall have a minimum weight of 30 lbs. including base.

1. Traffic cones and tubular markers shall be predominantly orange, and meet the height and weight requirements shown above.
2. One-piece cones have the body and base of the cone molded in one consolidated unit. Two-piece cones have a cone shaped body and a separate rubber base, or ballast, that is added to keep the device upright and in place.
3. Two-piece cones may have a handle or loop extending up to 8" above the minimum height shown, in order to aid in retrieving the device.
4. Cones or tubular markers shall have white or white and orange reflective bands as shown above. The reflective bands shall have a smooth, sealed outer surface and meet the requirements of Departmental Material Specification DMS-8300 Type A or Type B.
5. 28" cones and tubular markers are generally suitable for short duration and short-term stationary work as defined on BC(4). These should not be used for intermediate-term or long-term stationary work unless personnel is on-site to maintain them in their proper upright position.
6. 42" two-piece cones, vertical panels or drums are suitable for all work zone durations.
7. Cones or tubular markers used on each project should be of the same size and shape.



BARRICADE AND CONSTRUCTION CHANNELIZING DEVICES

BC (10) - 21

FILE: dc-21.dgn	DN: TxDOT	CR: TxDOT	DR: TxDOT	CK: TxDOT
REV: November 2002	CONT: 6417	SECT: 38	JOB: 001	HIGHWAY: US 96, etc.
9-07 8-14	DIST: LFK	COUNTY: San Augustine	SHEET NO.:	15
7-13 5-21				

The use of this standard is governed by the "Texas Engineering Practice Act". No warranty of any kind is made by the State of Texas for the use of this standard for other than the purposes intended. The use of this standard for other than the purposes intended may result in personal injury or property damage. The use of this standard for other than the purposes intended may result in personal injury or property damage. The use of this standard for other than the purposes intended may result in personal injury or property damage.

WORK ZONE PAVEMENT MARKINGS

GENERAL

1. The Contractor shall be responsible for maintaining work zone and existing pavement markings, in accordance with the standard specifications and special provisions, on all roadways open to traffic within the CSJ limits unless otherwise stated in the plans.
2. Color, patterns and dimensions shall be in conformance with the "Texas Manual on Uniform Traffic Control Devices" (TMUTCD).
3. Additional supplemental pavement marking details may be found in the plans or specifications.
4. Pavement markings shall be installed in accordance with the TMUTCD and as shown on the plans.
5. When short term markings are required on the plans, short term markings shall conform with the TMUTCD, the plans and details as shown on the Standard Plan Sheet WZ(S1PM).
6. When standard pavement markings are not in place and the roadway is opened to traffic, DO NOT PASS signs shall be erected to mark the beginning of the sections where passing is prohibited and PASS WITH CARE signs at the beginning of sections where passing is permitted.
7. All work zone pavement markings shall be installed in accordance with Item 662, "Work Zone Pavement Markings."

RAISED PAVEMENT MARKERS

1. Raised pavement markers are to be placed according to the patterns on BC(12).
2. All raised pavement markers used for work zone markings shall meet the requirements of Item 672, "RAISED PAVEMENT MARKERS" and Departmental Material Specification DMS-4200 or DMS-4300.

PREFABRICATED PAVEMENT MARKINGS

1. Removable prefabricated pavement markings shall meet the requirements of DMS-8241.
2. Non-removable prefabricated pavement markings (foil back) shall meet the requirements of DMS-8240.

MAINTAINING WORK ZONE PAVEMENT MARKINGS

1. The Contractor will be responsible for maintaining work zone pavement markings within the work limits.
2. Work zone pavement markings shall be inspected in accordance with the frequency and reporting requirements of work zone traffic control device inspections as required by Form 599.
3. The markings should provide a visible reference for a minimum distance of 300 feet during normal daylight hours and 160 feet when illuminated by automobile low-beam headlights at night, unless sight distance is restricted by roadway geometrics.
4. Markings failing to meet this criteria within the first 30 days after placement shall be replaced at the expense of the Contractor as per Specification Item 662.

REMOVAL OF PAVEMENT MARKINGS

1. Pavement markings that are no longer applicable, could create confusion or direct a motorist toward or into the closed portion of the roadway shall be removed or obliterated before the roadway is opened to traffic.
2. The above shall not apply to detours in place for less than three days, where flaggers and/or sufficient channelizing devices are used in lieu of markings to outline the detour route.
3. Pavement markings shall be removed to the fullest extent possible, so as not to leave a discernable marking. This shall be by any method approved by TxDOT Specification Item 677 for "Eliminating Existing Pavement Markings and Markers".
4. The removal of pavement markings may require resurfacing or seal coating portions of the roadway as described in Item 677.
5. Subject to the approval of the Engineer, any method that proves to be successful on a particular type pavement may be used.
6. Blast cleaning may be used but will not be required unless specifically shown in the plans.
7. Over-painting of the markings SHALL NOT BE permitted.
8. Removal of raised pavement markers shall be as directed by the Engineer.
9. Removal of existing pavement markings and markers will be paid for directly in accordance with Item 677, "ELIMINATING EXISTING PAVEMENT MARKINGS AND MARKERS," unless otherwise stated in the plans.
10. Black-out marking tape may be used to cover conflicting existing markings for periods less than two weeks when approved by the Engineer.

Temporary Flexible-Reflective Roadway Marker Tabs

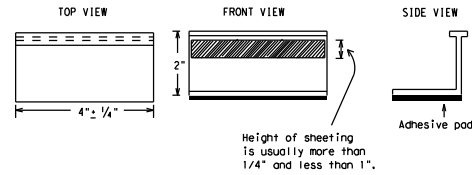

STAPLES OR NAILS SHALL NOT BE USED TO SECURE TEMPORARY FLEXIBLE-REFLECTIVE ROADWAY MARKER TABS TO THE PAVEMENT SURFACE

1. Temporary flexible-reflective roadway marker tabs used as guidemarks shall meet the requirements of DMS-8242.
2. Tabs detailed on this sheet are to be inspected and accepted by the Engineer or designated representative. Sampling and testing is not normally required, however at the option of the Engineer, either "A" or "B" below may be imposed to assure quality before placement on the roadway.
 - A. Select five (5) or more tabs at random from each lot or shipment and submit to the Construction Division, Materials and Pavement Section to determine specification compliance.
 - B. Select five (5) tabs and perform the following test. Affix five (5) tabs at 24 inch intervals on an asphaltic pavement in a straight line. Using a medium size passenger vehicle or pickup, run over the markers with the front and rear tires at a speed of 35 to 40 miles per hour, four (4) times in each direction. No more than one (1) out of the five (5) reflective surfaces shall be lost or displaced as a result of this test.
3. Small design variances may be noted between tab manufacturers.
4. See Standard Sheet WZ(S1PM) for tab placement on new pavements. See Standard Sheet TCP(7-1) for tab placement on seal coat work.

RAISED PAVEMENT MARKERS USED AS GUIDEMARKS

1. Raised pavement markers used as guidemarks shall be from the approved product list, and meet the requirements of DMS-4200.
2. All temporary construction raised pavement markers provided on a project shall be of the same manufacturer.
3. Adhesive for guidemarks shall be bituminous material hot applied or butyl rubber pad for all surfaces, or thermoplastic for concrete surfaces.

Guidemarks shall be designated as:
 YELLOW - (two amber reflective surfaces with yellow body).
 WHITE - (one silver reflective surface with white body).

DEPARTMENTAL MATERIAL SPECIFICATIONS	
PAVEMENT MARKERS (REFLECTORIZED)	DMS-4200
TRAFFIC BUTTONS	DMS-4300
EPOXY AND ADHESIVES	DMS-6100
BITUMINOUS ADHESIVE FOR PAVEMENT MARKERS	DMS-6130
PERMANENT PREFABRICATED PAVEMENT MARKINGS	DMS-8240
TEMPORARY REMOVABLE, PREFABRICATED PAVEMENT MARKINGS	DMS-8241
TEMPORARY FLEXIBLE, REFLECTIVE ROADWAY MARKER TABS	DMS-8242

A list of prequalified reflective raised pavement markers, non-reflective traffic buttons, roadway marker tabs and other pavement markings can be found at the Material Producer List web address shown on BC(1).

SHEET 11 OF 12



BARRICADE AND CONSTRUCTION PAVEMENT MARKINGS

BC(11)-21

FILE: bc-21.dgn	DN: TxDOT	CR: TxDOT	DN: TxDOT	CR: TxDOT
CONT: February 1998	SECT: 6417	JOB: 38	US 96, etc.	HIGHWAY: 001
REVISIONS: 2-98 9-07 5-21	DIST: LFK	COUNTY: San Augustine	SHEET NO. 16	
1-02 7-13				
11-02 8-14				

105

PAVEMENT MARKING PATTERNS

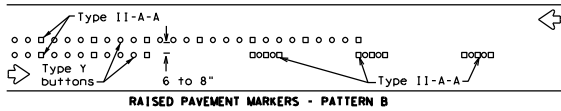
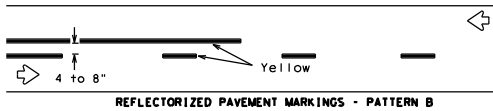
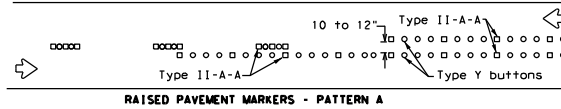
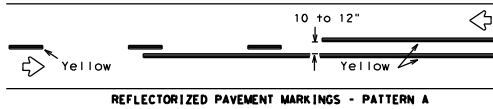

Pattern A is the TXDOT Standard, however Pattern B may be used if approved by the Engineer. Prefabricated markings may be substituted for reflectORIZED pavement markings.

CENTER LINE & NO-PASSING ZONE BARRIER LINES FOR TWO-LANE, TWO-WAY HIGHWAYS

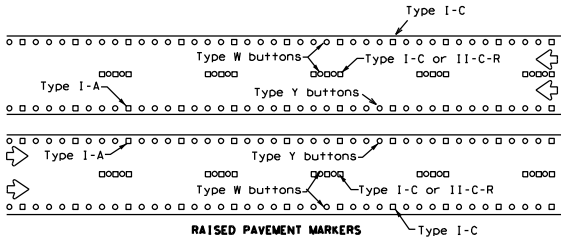
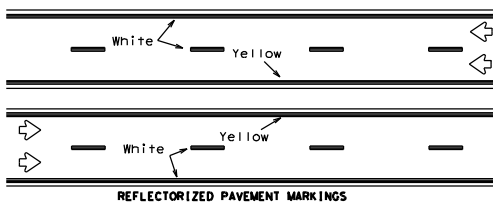

Prefabricated markings may be substituted for reflectORIZED pavement markings.

EDGE & LANE LINES FOR DIVIDED HIGHWAY

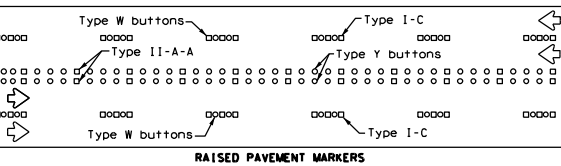
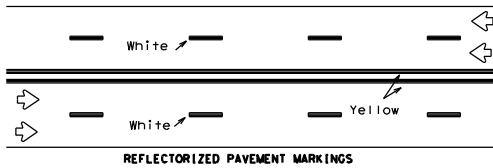

Prefabricated markings may be substituted for reflectORIZED pavement markings.

LANE & CENTER LINES FOR MULTILANE UNDIVIDED HIGHWAYS

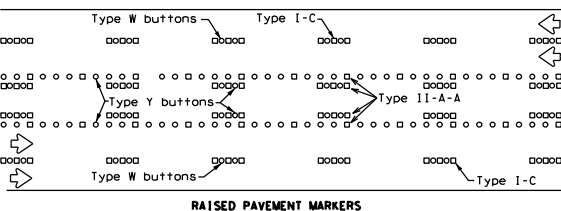
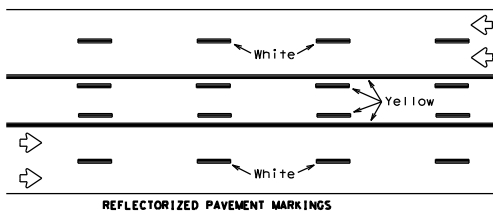

Prefabricated markings may be substituted for reflectORIZED pavement markings.

TWO-WAY LEFT TURN LANE

STANDARD WORK ZONE PAVEMENT MARKINGS DETAILS

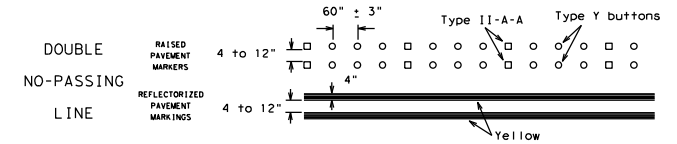

SOLID LINES

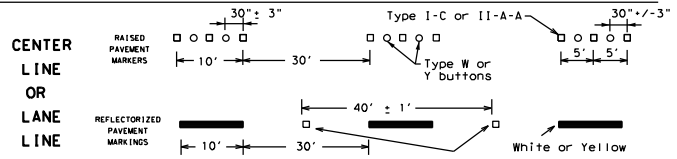
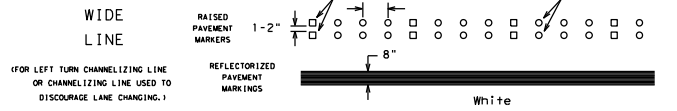
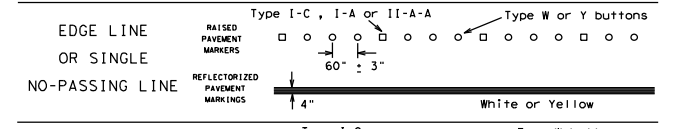

BROKEN LINES

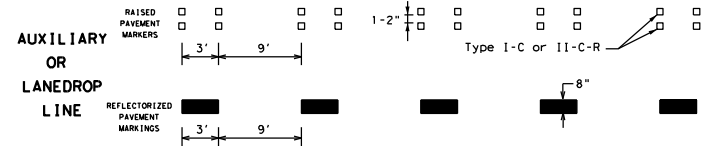

REMOVABLE MARKINGS WITH RAISED PAVEMENT MARKERS

If raised pavement markers are used to supplement REMOVABLE markings, the markers shall be applied to the top of the tape at the approximate mid length of tape used for broken lines or at 20 foot spacing for solid lines. This allows an easier removal of raised pavement markers and tape.

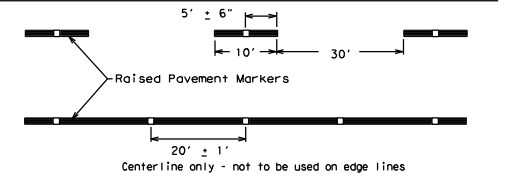

SHEET 12 OF 12



BARRICADE AND CONSTRUCTION PAVEMENT MARKING PATTERNS

BC (12) - 21

Raised pavement markers used as standard pavement markings shall be from the approved products list and meet the requirements of Item 672 "RAISED PAVEMENT MARKERS."

FILE: bc-21.dgn	DN: TXDOT	CR: TXDOT	DR: TXDOT	EX: TXDOT
© TXDOT February 1998	CONT	SECT	JOB	HIGHWAY
1-97 9-07 5-21	6417	38	001	US 96, etc.
2-98 7-13	DIST	COUNTY	SHEET NO.	
11-02 8-14	LFK	San Augustine	17	

DISCLAIMER: The use of this standard is governed by the "Texas Engineering Practice Act". No warranty of any kind is made by the author of this standard or by the publisher for incorrect results or damages resulting from its use.

DATE: 11/17/2022 12:52:40 PM
FILE: T:\LFK\DM\Int\Contracts\0.RMC - Routine Maintenance Contracts\123 Plans\6417-38-001 San Augustine M&F-DDN-STANDARD-TRAFFIC-BC(12)-21.dgn

DISCLAIMER: The use of this standard is governed by the "Texas Engineering Practice Act". No warranty of an kind is made by TxDOT for any purpose whatsoever. TxDOT assumes no responsibility for the conversion of this standard to other formats or for indirect results or damages resulting from its use.
 DATE: 11/17/2022 12:53:23 PM
 FILE: T:\LFK\DM\Main\Traffic\00.RMC - Routine Maintenance Contracts\FY23 Plans\417-38-001 San Augustine MBGF\DDN\STANDARD\TRAFFIC\TCP (2-1)-18.dgn

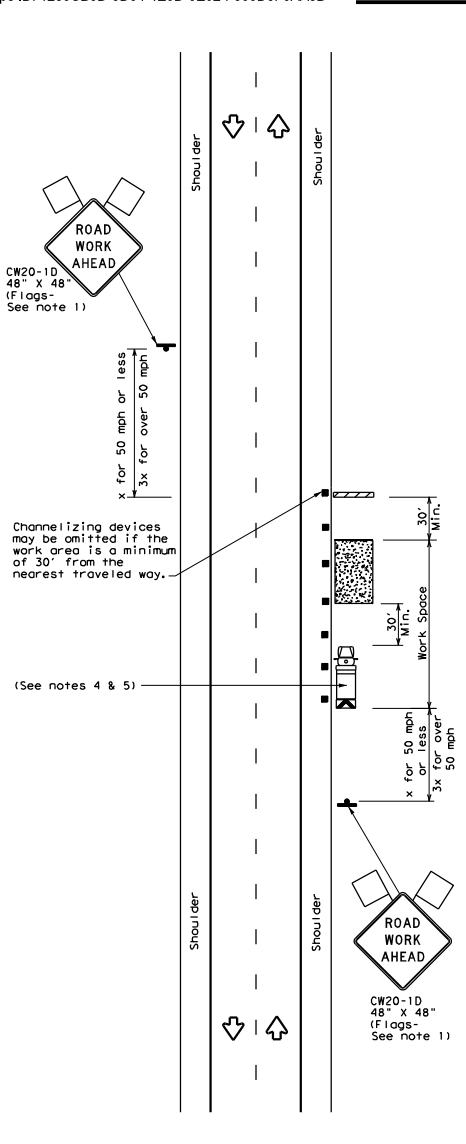

TCP (2-1a)

WORK SPACE NEAR SHOULDER
Conventional Roads

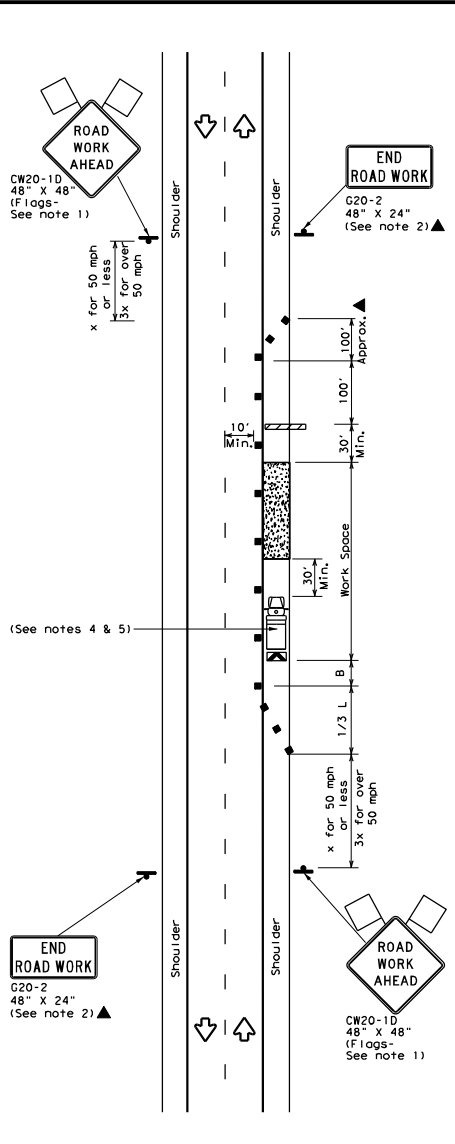

TCP (2-1b)

WORK SPACE ON SHOULDER
Conventional Roads

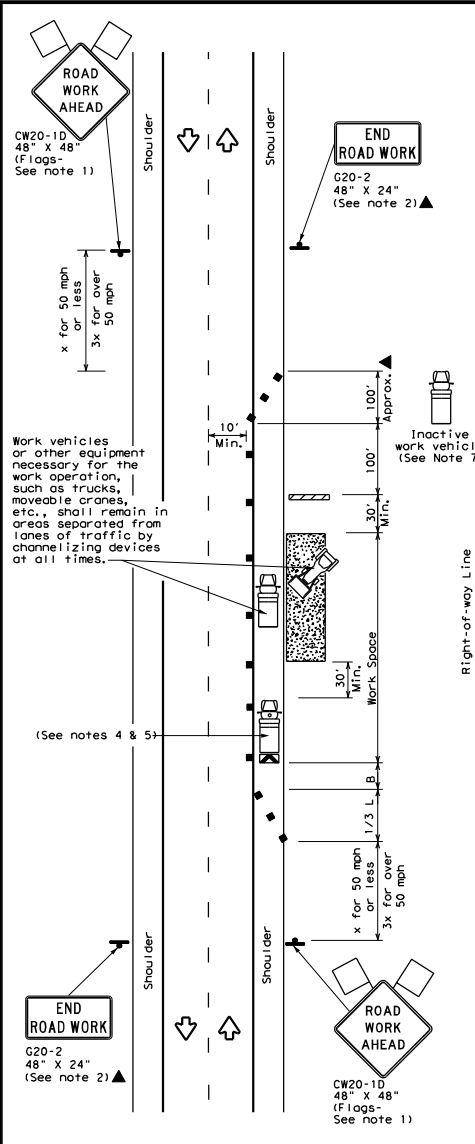

TCP (2-1c)

WORK VEHICLES ON SHOULDER
Conventional Roads

LEGEND			
	Type 3 Barricade		Channelizing Devices
	Heavy Work Vehicle		Truck Mounted Attenuator (TMA)
	Trailer Mounted Flashing Arrow Board		Portable Changeable Message Sign (PCMS)
	Sign		Traffic Flow
	Flag		Flagger

Posted Speed * *	Formula	Minimum Desirable Taper Lengths **			Suggested Maximum Spacing of Channelizing Devices		Minimum Sign Spacing * Distance	Suggested Longitudinal Buffer Space * B'
		10' Offset	11' Offset	12' Offset	On a Taper	On a Tangent		
30	$L = \frac{WS^2}{60}$	150'	165'	180'	30'	60'	120'	90'
35		205'	225'	245'	35'	70'	160'	120'
40	$L = WS$	265'	295'	320'	40'	80'	240'	155'
45		450'	495'	540'	45'	90'	320'	195'
50	$L = WS$	500'	550'	600'	50'	100'	400'	240'
55		550'	605'	660'	55'	110'	500'	295'
60	$L = WS$	600'	660'	720'	60'	120'	600'	350'
65		650'	715'	780'	65'	130'	700'	410'
70	$L = WS$	700'	770'	840'	70'	140'	800'	475'
75		750'	825'	900'	75'	150'	900'	540'

* Conventional Roads Only
 ** Taper lengths have been rounded off.
 L=Length of Taper (FT) W=Width of Offset (FT) S=Posted Speed (MPH)

TYPICAL USAGE				
MOBILE	SHORT DURATION	SHORT TERM STATIONARY	INTERMEDIATE TERM STATIONARY	LONG TERM STATIONARY
	✓	✓	✓	✓

- GENERAL NOTES**
- Flags attached to signs where shown, are REQUIRED.
 - All traffic control devices illustrated are REQUIRED, except those denoted with the triangle symbol may be omitted when stated in the plans, or for routine maintenance work, when approved by the Engineer.
 - Stockpiled material should be placed a minimum of 30 feet from nearest traveled way.
 - Shadow Vehicle with TMA and high intensity rotating, flashing, oscillating or strobe lights. A Shadow Vehicle with a TMA should be used anytime it can be positioned 30 to 100 feet in advance of the area of crew exposure without adversely affecting the performance or quality of the work. If workers are no longer present but road or work conditions require the traffic control to remain in place, Type 3 Barricades or other channelizing devices may be substituted for the Shadow Vehicle and TMA.
 - Additional Shadow Vehicles with TMAs may be positioned off the paved surface, next to those shown in order to protect a wider work space.
 - See TCP(5-1) for shoulder work on divided highways, expressways and freeways.
 - Inactive work vehicles or other equipment should be parked near the right-of-way line and not parked on the paved shoulder.
 - CW21-5 "SHOULDER WORK" signs may be used in place of CW20-1D "ROAD WORK AHEAD" signs for shoulder work on conventional roadways.



TRAFFIC CONTROL PLAN
CONVENTIONAL ROAD
SHOULDER WORK

TCP (2-1) - 18

FILE: tcp2-1-18.dgn	DATE: December 1985	CONTRACT: 6417	SECTION: 38	JOB: 001	COUNTY: US 96, etc.
REVISIONS:					
2-94 4-98					
8-95 2-12					
1-97 2-18		DIST: LFK		SAN AUGUSTINE	SHEET NO. 18

DISCLAIMER: This standard is governed by the "Texas Engineering Practice Act". No warranty, of any kind is made by TxDOT for any purpose whatsoever. TxDOT assumes no responsibility for the conversion of this standard to other formats or for incorrect, incomplete, or damaged resulting from its use.

DATE: 11/17/2022 12:53:24 PM
 FILE: T:\EFD\MAINT\contracts\0-RMC - Routine Maintenance Contracts\123 Plans\17-38-001 San Augustine M&F\DDN\STANDARD\TRAFFIC\TCP (2-2)-18.dgn

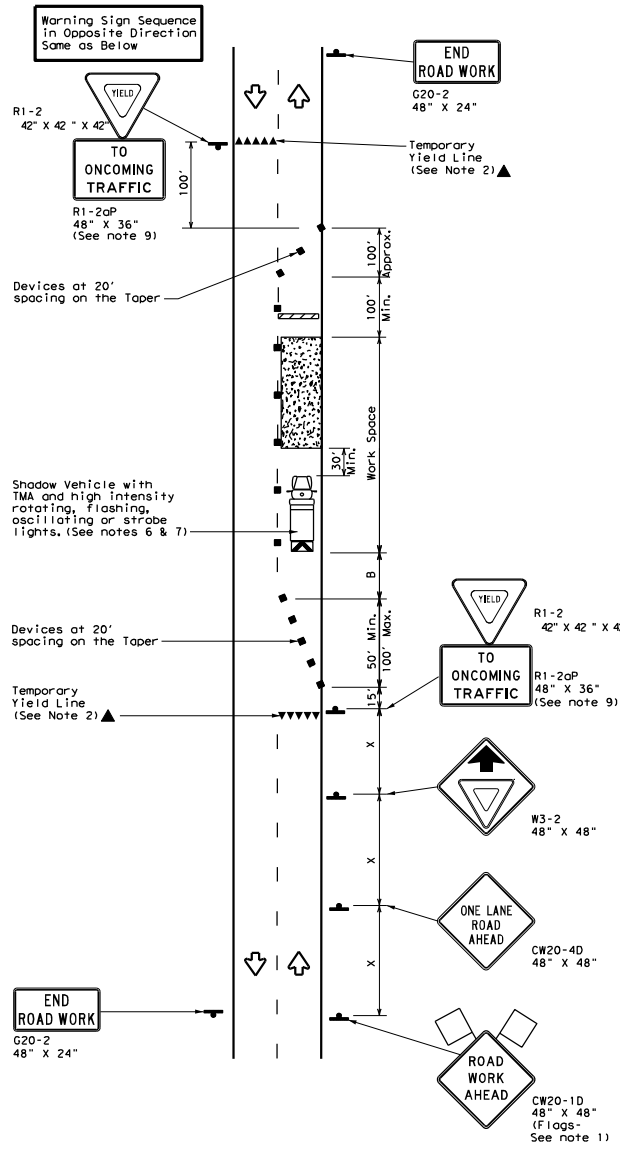

TCP (2-2a)
 2-LANE ROADWAY WITHOUT PAVED SHOULDERS
ONE LANE TWO-WAY
CONTROL WITH YIELD SIGNS
 (Less than 2000 ADT - See Note 9)

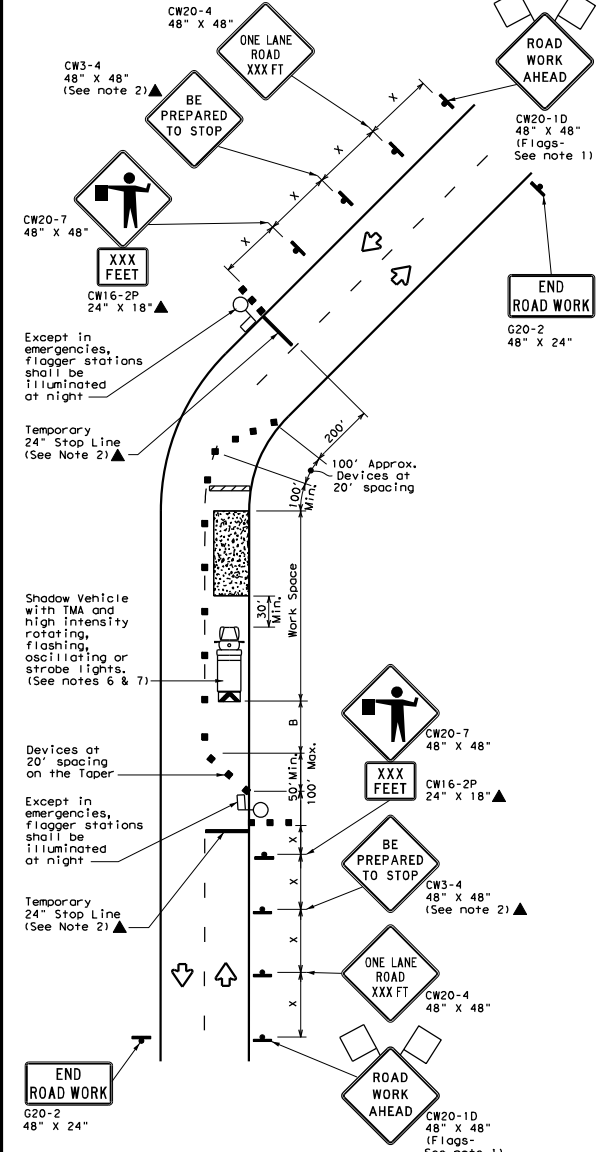

TCP (2-2b)
 2-LANE ROADWAY WITHOUT PAVED SHOULDERS
ONE LANE TWO-WAY
CONTROL WITH FLAGGERS

LEGEND			
	Type 3 Barricade		Channelizing Devices
	Heavy Work Vehicle		Truck Mounted Attenuator (TMA)
	Trailer Mounted Flashing Arrow Board		Portable Changeable Message Sign (PCMS)
	Sign		Traffic Flow
	Flag		Flagger

Posted Speed * *	Formula	Minimum Desirable Taper Lengths **			Suggested Maximum Spacing of Channelizing Devices		Minimum Sign Spacing "x" Distance	Suggested Longitudinal Buffer Space "b"	Stopping Sight Distance
		10' Offset	11' Offset	12' Offset	On a Taper	On a Tangent			
30	L = WS ² / 60	150'	165'	180'	30'	60'	120'	90'	200'
35		205'	225'	245'	35'	70'	160'	120'	250'
40		265'	295'	320'	40'	80'	240'	155'	305'
45		450'	495'	540'	45'	90'	320'	195'	360'
50	L = WS	500'	550'	600'	50'	100'	400'	240'	425'
55		550'	605'	660'	55'	110'	500'	295'	495'
60		600'	660'	720'	60'	120'	600'	350'	570'
65		650'	715'	780'	65'	130'	700'	410'	645'
70		700'	770'	840'	70'	140'	800'	475'	730'
75		750'	825'	900'	75'	150'	900'	540'	820'

* Conventional Roads Only
 ** Taper lengths have been rounded off.
 L=Length of Taper(FT) W=Width of Offset(FT) S=Posted Speed(MPH)

TYPICAL USAGE			
MOBILE	SHORT DURATION	SHORT TERM STATIONARY	LONG TERM STATIONARY
	✓	✓	✓

GENERAL NOTES

- Flags attached to signs where shown, are REQUIRED.
 - All traffic control devices illustrated are REQUIRED, except those denoted with the triangle symbol may be omitted when stated elsewhere in the plans, or for routine maintenance work, when approved by the Engineer.
 - The CW3-4 "BE PREPARED TO STOP" sign may be installed after the CW20-4 "ONE LANE ROAD XXX FT" sign, but proper sign spacing shall be maintained.
 - Flaggers should use two-way radios or other methods of communication to control traffic.
 - Length of work space should be based on the ability of flaggers to communicate.
 - A Shadow Vehicle with a TMA should be used anytime it can be positioned 30 to 100 feet in advance of the area of crew exposure without adversely affecting the performance or quality of the work. If workers are no longer present but road or work conditions require the traffic control to remain in place, Type 3 Barricades or other channelizing devices may be substituted for the Shadow Vehicle and TMA.
 - Additional Shadow Vehicles with TMAs may be positioned off the paved surface, next to those shown in order to protect a wider work space.
- TCP (2-2a)**
- The R1-2 "YIELD" sign traffic control may be used on projects with approaches that have adequate sight distance. For projects in urban areas, work space should be no longer than one half city block. In rural areas, roadways with less than 2000 ADT, work space should be no longer than 400 feet.
 - The R1-2aP "YIELD TO ONCOMING TRAFFIC" sign shall be placed on a support of a 7 foot minimum mounting height.
- TCP (2-2b)**
- Channelizing devices on the center line may be omitted when a pilot car is leading traffic and approved by the Engineer.
 - If the work space is located near a horizontal or vertical curve, the buffer distances should be increased in order to maintain stopping sight distance to the flagger and a queue of stopped vehicles. (See table above).
 - Flaggers should use 24" STOP/SLOW paddles to control traffic. Flags should be limited to emergency situations.

				Traffic Operations Standard	
TRAFFIC CONTROL PLAN					
ONE-LANE TWO-WAY					
TRAFFIC CONTROL					
TCP (2-2) - 18					
FILE#	tcp2-2-18.dgn	DATE	DEC	1985	
CONTRACT	6417	SECTION	38	JOB	HIGHWAY
REVISIONS	8-95 3-03	DIST	001	COUNTY	US 96, etc.
	1-97 2-12				SHEET NO.
	4-98 2-18	LFK	San Augustine		19

DATE: 11/17/2022 12:53:25 PM
 FILE: T:\NF\KDM\mnt\contracts\0_RMC - Routine Maintenance Contracts\1723 Plans\6417-38-001 San Augustine MBGF\DDN\STANDARD\TRAFFIC\TCP (2-3)-18.dgn
 DISCLAIMER: The use of this standard is governed by the Texas Engineering Practice Act. No warranty of any kind is made by the author or publisher for the use of this standard or for incorrect results or damages resulting from its use.

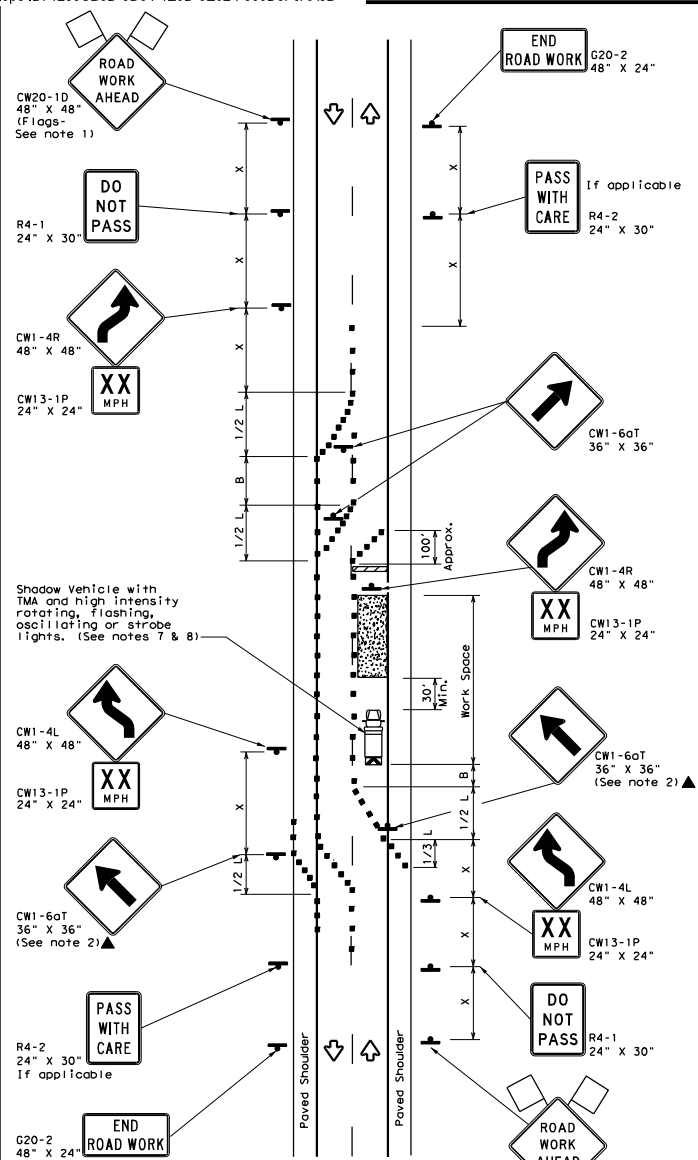

TCP (2-3a)
2-LANE ROADWAY WITH PAVED SHOULDERS
ONE LANE CLOSED
ADEQUATE FIELD OF VIEW

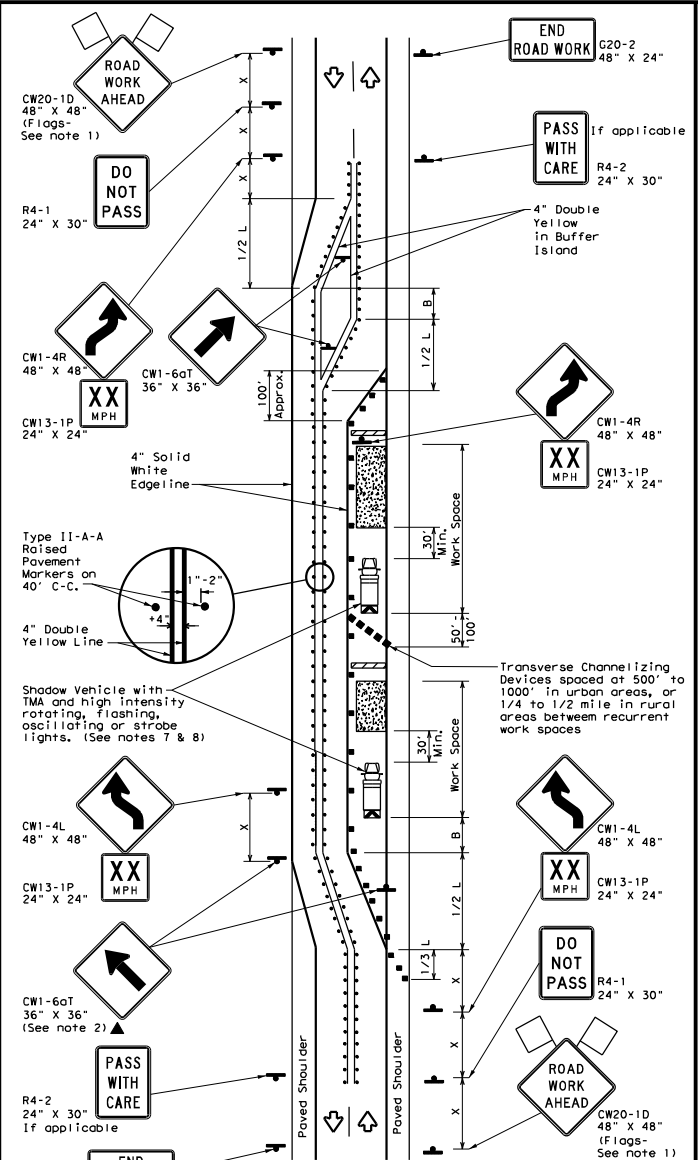

TCP (2-3b)
2-LANE ROADWAY WITH PAVED SHOULDERS
ONE LANE CLOSED
INADEQUATE FIELD OF VIEW

LEGEND			
	Type 3 Barricade		Channelizing Devices
	Heavy Work Vehicle		Truck Mounted Attenuator (TMA)
	Trailer Mounted Flashing Arrow Board		Raised Pavement Markers Ty II-AA
	Sign		Traffic Flow
	Flag		Flagger

Posted Speed "S"	Formula	Minimum Desirable Taper Lengths "X"			Suggested Maximum Spacing of Channelizing Devices		Minimum Sign Spacing "Y"	Suggested Longitudinal Buffer Space "B"
		10' Offset	11' Offset	12' Offset	On a Taper	On a Tangent		
30	L = WS ² / 60	150'	165'	180'	30'	60'	120'	90'
35		205'	225'	245'	35'	70'	160'	120'
40	L = WS	265'	295'	320'	40'	80'	240'	155'
45		450'	495'	540'	45'	90'	320'	195'
50	L = WS	500'	550'	600'	50'	100'	400'	240'
55		550'	605'	660'	55'	110'	500'	295'
60	L = WS	600'	660'	720'	60'	120'	600'	350'
65		650'	715'	780'	65'	130'	700'	410'
70	L = WS	700'	770'	840'	70'	140'	800'	475'
75		750'	825'	900'	75'	150'	900'	540'

* Conventional Roads Only
 ** Taper lengths have been rounded off.
 L=Length of Taper (FT) W=Width of Offset (FT) S=Posted Speed (MPH)

MOBILE	TYPICAL USAGE			
	SHORT DURATION	SHORT TERM STATIONARY	INTERMEDIATE TERM STATIONARY	LONG TERM STATIONARY
			✓	✓

- GENERAL NOTES**
- Flags attached to signs where shown, are REQUIRED.
 - All traffic control devices illustrated are REQUIRED, except those denoted with the triangle symbol may be omitted when stated elsewhere in the plans, or for routine maintenance work, when approved by the Engineer.
 - When work space will be in place less than three days existing pavement markings may remain in place. Channelizing devices shall be used to separate traffic.
 - Flagger control should NOT be used unless roadway conditions or heavy traffic volume require additional emphasis to safely control traffic. Flagger should be positioned at end of traffic queue.
 - The R4-1 "DO NOT PASS," R4-2 "PASS WITH CARE" and construction regulatory speed zone signs may be installed within CW20-1D "ROAD WORK AHEAD" signs. Proper spacing of signs shall be maintained.
 - Conflicting pavement marking shall be removed for long term projects.
 - A Shadow Vehicle with a TMA should be used anytime it can be positioned 30 to 100 feet in advance of the area of crew exposure without adversely affecting the performance or quality of the work. If workers are no longer present but road or work conditions require the traffic control to remain in place, Type 3 Barricades or other channelizing devices may be substituted.
 - Additional Shadow Vehicles with TMAs may be positioned off the paved surface, next to those shown in order to protect a wider work space.

TCP (2-3a)
 9. Conflicting pavement markings shall be removed for long-term projects. For shorter durations where traffic is directed over a yellow centerline, channelizing devices which separate two-way traffic should be spaced on tapers at 20' or 15' if posted speeds are 35 mph or slower, and for tangent sections, at 1/2(5) where 5 is the speed in mph. This tighter device spacing is intended for the area of the conflicting markings, not the entire work zone.

		Traffic Operations Division Standard	
TRAFFIC CONTROL PLAN TRAFFIC SHIFTS ON TWO-LANE ROADS			
TCP (2-3)-18			
FILE: tcp(2-3)-18.dgn	DATE: 6/17/2018	CONTRACT: 6417-38	COUNTY: 001
PROJECT: 8-95 3-01	REVISIONS: 1-97 2-12	DIST: LFK	COUNTY: San Augustine
DATE: 4-98 2-18			SHEET NO. 20

DISCLAIMER: This standard is covered by the "Texas Engineering Practices Act". No warranty of any kind is made by TxDOT for any purpose whatsoever. TxDOT disclaims all responsibility for the consequences of this standard to other formats or for incorrect results or damages resulting from its use.

DATE: 11/17/2022 12:53:26 PM
 FILE: T:\LKFDMA\Int\Contracts\0-RMC - Routine Maintenance Contracts\FY23 Plans\6417-38-001 San Augustine MBGF\DDN\STANDARD\TRAFFIC\TCP (2-4)-18.dgn

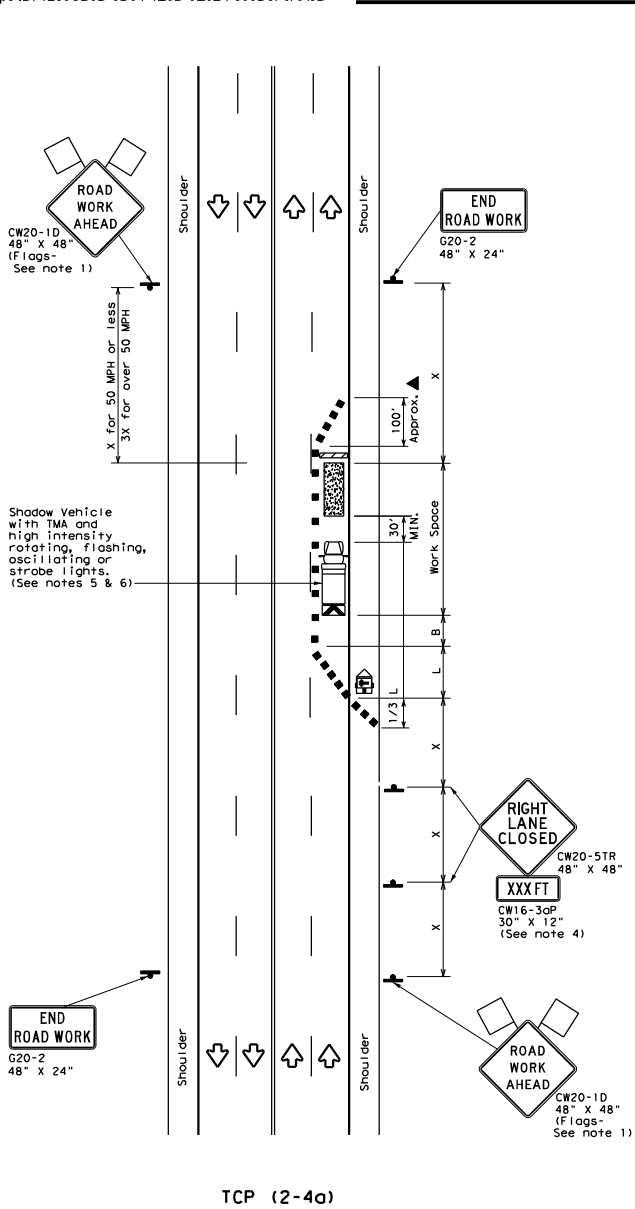

TCP (2-4a)
ONE LANE CLOSED

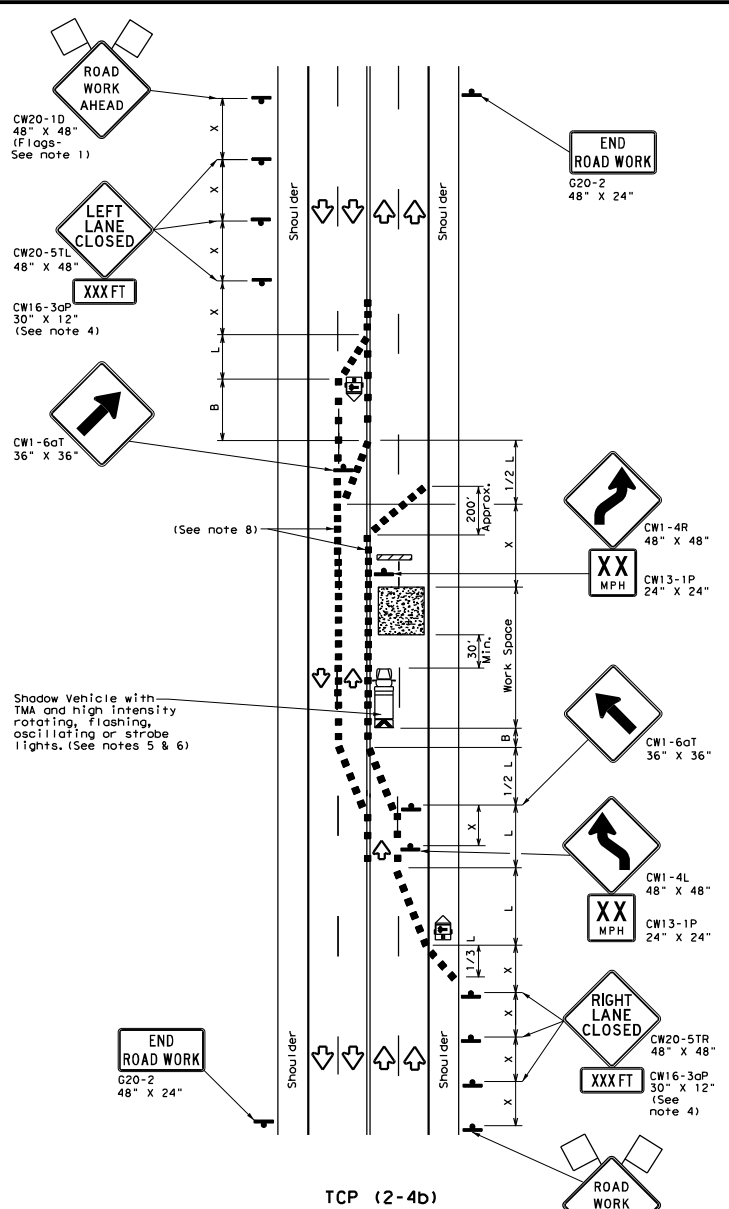

TCP (2-4b)
TWO LANES CLOSED

LEGEND			
	Type 3 Barricade		Channelizing Devices
	Heavy Work Vehicle		Truck Mounted Attenuator (TMA)
	Trailer Mounted Flashing Arrow Board		Portable Changeable Message Sign (PCMS)
	Sign		Traffic Flow
	Flag		Flagger

Posted Speed	Formula	Minimum Desirable Taper Lengths * X			Suggested Maximum Spacing of Channelizing Devices		Minimum Sign Spacing Distance	Suggested Longitudinal Buffer Space "B"
		10' Offset	11' Offset	12' Offset	On a Taper	On a Tangent		
30	$L = \frac{WS^2}{60}$	150'	165'	180'	30'	60'	120'	90'
35		205'	225'	245'	35'	70'	160'	120'
40		265'	295'	320'	40'	80'	240'	155'
45		330'	365'	390'	45'	90'	320'	195'
50	$L = WS$	500'	550'	600'	50'	100'	400'	240'
55		550'	605'	660'	55'	110'	500'	295'
60		600'	660'	720'	60'	120'	600'	350'
65		650'	715'	780'	65'	130'	700'	410'
70		700'	770'	840'	70'	140'	800'	475'
75		750'	825'	900'	75'	150'	900'	540'

* Conventional Roads Only
 ** Taper lengths have been rounded off.
 L=Length of Taper (FT) W=Width of Offset (FT) S=Posted Speed (MPH)

MOBILE	TYPICAL USAGE			
	SHORT DURATION	SHORT TERM STATIONARY	INTERMEDIATE TERM STATIONARY	LONG TERM STATIONARY
		✓	✓	

- GENERAL NOTES**
- Flags attached to signs where shown, are REQUIRED.
 - All traffic control devices illustrated are REQUIRED, except those denoted with the triangle symbol may be omitted when stated elsewhere in the plans, or for routine maintenance work, when approved by the Engineer.
 - The downstream taper is optional. When used, it should be 100 feet minimum length per lane.
 - For short term applications, when post mounted signs are not used, the distance legend may be shown on the sign face rather than on a CW16-3aP supplemental plaque.
 - A Shadow Vehicle with a TMA should be used anytime it can be positioned 30 to 100 feet in advance of the area of crew exposure without adversely affecting the performance or quality of the work. If workers are no longer present but road or work conditions require the traffic control to remain in place, Type 3 Barricades or other channelizing devices may be substituted for the Shadow Vehicle and TMA.
 - Additional Shadow Vehicles with TMAs may be positioned in each closed lane, on the shoulder or off the paved surface, next to those shown in order to protect a wider work space.
- TCP (2-4a)**
- If this TCP is used for a left lane closure, CW20-5TL "LEFT LANE CLOSED" signs shall be used and channelizing devices shall be placed on the centerline to protect the work space from opposing traffic with the arrow board placed in the closed lane near the end of the merging taper.
- TCP (2-4b)**
- For shorter durations where traffic is directed over a yellow centerline, channelizing devices which separate two-way traffic should be spaced on tapers at 20' or 15' if posted speeds are 35 mph or slower, and for tangent sections, at 1/2(5) where S is the speed in mph. This tighter device spacing is intended for the area of conflicting markings, not the entire work zone.

Traffic Operations Division Standard

**TRAFFIC CONTROL PLAN
 LANE CLOSURES ON MULTILANE
 CONVENTIONAL ROADS**

TCP (2-4) - 18

FILE: tcp2-4-18.dgn	DATE: 12/01/1985	CONTRACT: 6417-38	SECTION: 001	JOB: COUNTY	CITY: SAN AUGUSTINE
REVISIONS		DATE	BY	REASON	
8-95 3-01		6417-38	001	US 96, etc.	
1-97 2-12					
4-98 2-18					
LFK San Augustine					21

164

DATE: 11/17/2022 12:53:27 PM
 FILE: T:\LKFDOM\Main\Contract\03.RMC - Routine Maintenance Contracts\123 Plans\6417-38-001 San Augustine MBGF\DDN\STANDARD\TRAFFIC\TCP (2-5)-18.dgn
 DISCLAIMER: If this standard is observed by the "Texas Engineering Practices Act". No warranty of any kind is made by TxDOT for any purpose whatsoever. TxDOT assumes no responsibility for the conversion of this standard to other formats or for incorrect results or damages resulting from its use.
 San Augustine MBGF\DDN\STANDARD\TRAFFIC\TCP (2-5)-18.dgn

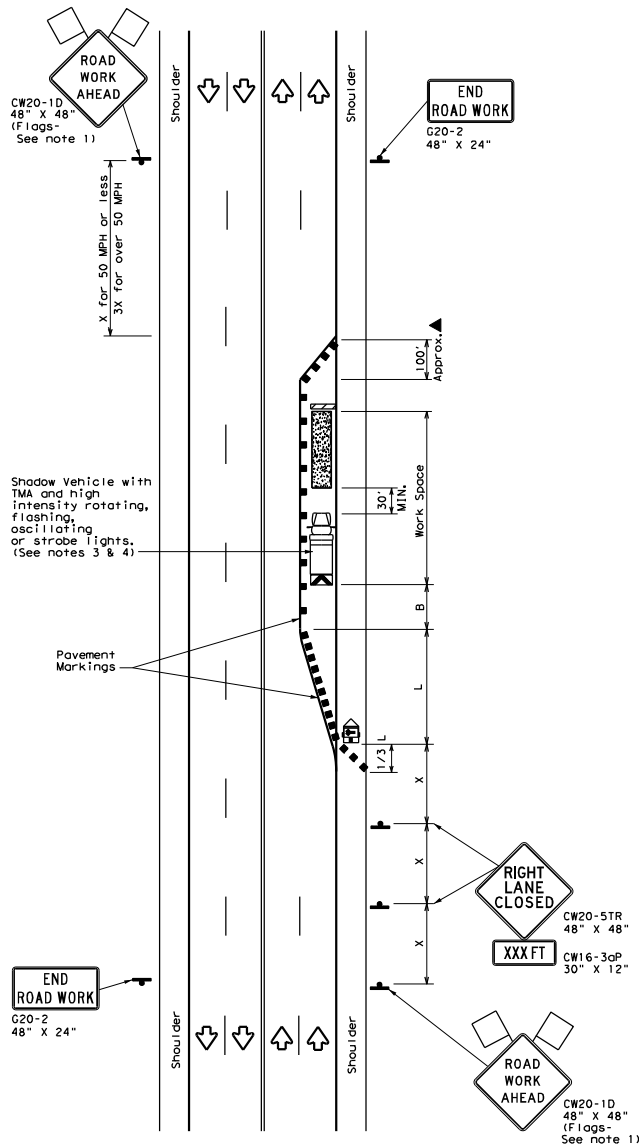

TCP (2-5a)
ONE LANE CLOSED

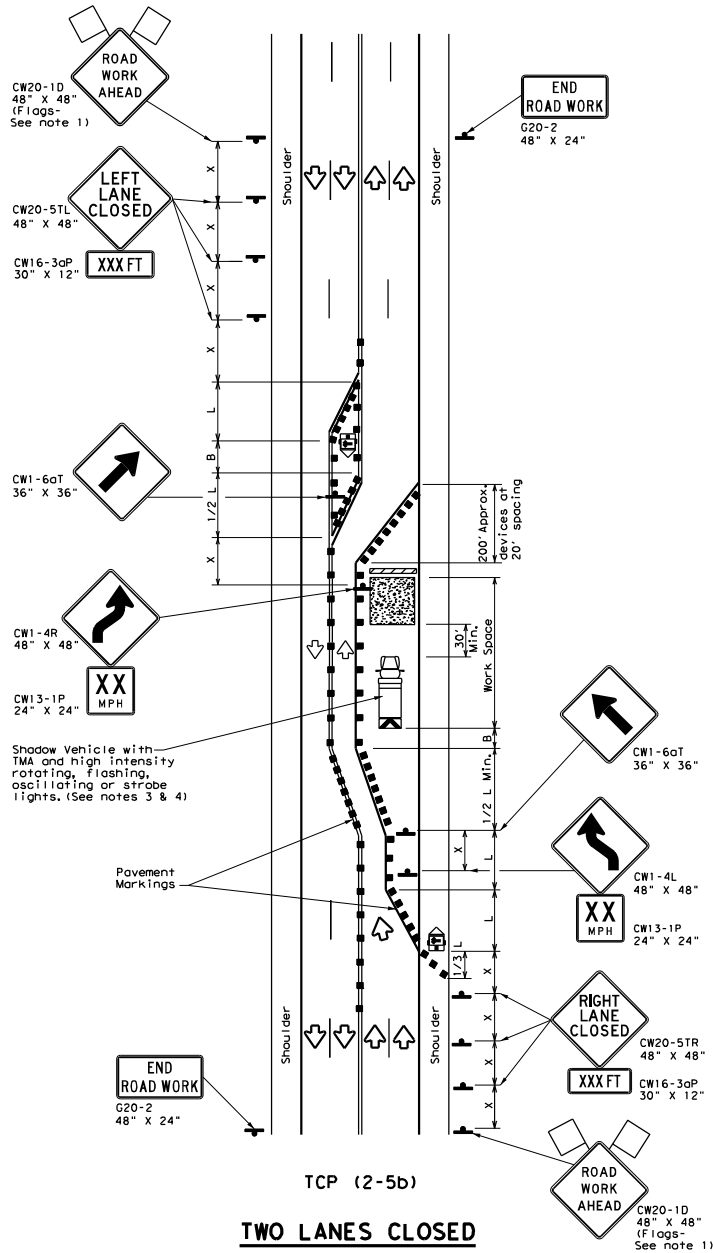

TCP (2-5b)
TWO LANES CLOSED

LEGEND			
	Type 3 Barricade		Channelizing Devices
	Heavy Work Vehicle		Truck Mounted Attenuator (TMA)
	Trailer Mounted Flashing Arrow Board		Portable Changeable Message Sign (PCMS)
	Sign		Traffic Flow
	Flag		Flagger

Posted Speed x	Formula L = WS ² /60	Minimum Desirable Taper Lengths			Suggested Maximum Spacing of Channelizing Devices		Minimum Sign Spacing "x" Distance	Suggested Longitudinal Buffer Space "B"
		10' Offset	11' Offset	12' Offset	On a Taper	On a Tangent		
30	L = WS ² /60	150'	165'	180'	30'	60'	120'	90'
35		205'	225'	245'	35'	70'	160'	120'
40		265'	295'	320'	40'	80'	240'	155'
45		450'	495'	540'	45'	90'	320'	195'
50		500'	550'	600'	50'	100'	400'	240'
55	L = WS	550'	605'	660'	55'	110'	500'	295'
60		600'	660'	720'	60'	120'	600'	350'
65		650'	715'	780'	65'	130'	700'	410'
70		700'	770'	840'	70'	140'	800'	475'
75		750'	825'	900'	75'	150'	900'	540'

x Conventional Roads Only
 ** Taper lengths have been rounded off.
 L-Length of Taper (FT) W-Width of Offset (FT) S-Posted Speed (MPH)

TYPICAL USAGE				
MOBILE	SHORT DURATION	SHORT TERM STATIONARY	INTERMEDIATE TERM STATIONARY	LONG TERM STATIONARY
			✓	✓

GENERAL NOTES

- Flags attached to signs where shown, are REQUIRED.
 - All traffic control devices illustrated are REQUIRED, except those denoted with the triangle symbol may be omitted when stated elsewhere in the plans, or for routine maintenance work, when approved by the Engineer.
 - A Shadow Vehicle with a TMA should be used anytime it can be positioned 30 to 100 feet in advance of the area of crew exposure without adversely affecting the performance or quality of the work. If workers are no longer present but road or work conditions require the traffic control to remain in place, Type 3 Barricades or other channelizing devices may be substituted for the Shadow Vehicle and TMA.
 - Additional Shadow Vehicles with TMAs may be positioned in each closed lane, on the shoulder or off the paved surface, next to those shown in order to protect a wider work space.
 - The downstream taper is optional. When used, it should be 100 feet approximately per lane, with channelizing devices spaced at 20 feet.
- TCP (2-5a)**
- If this TCP is used for a left lane closure, CW20-5TL "LEFT LANE CLOSED" signs shall be used and channelizing devices shall be placed on the centerline to protect the work space from opposing traffic, with the arrow board placed in the closed lane near the end of the merging taper.
- TCP (2-5b)**
- Conflicting pavement markings shall be removed for long-term projects.

		Traffic Operations Division Standard	
TRAFFIC CONTROL PLAN LONG TERM LANE CLOSURES MULTILANE CONVENTIONAL RDS.			
TCP (2-5) - 18			
FILE: tcp2-5-18.dgn	DATE: December 1985	CONTRACT: 6417	SECTION: 38
REVISIONS: 8-95 2-12		JOB: 001	HIGHWAY: US 96, etc.
1-97 3-03		DIST: COUNTY	SHEET NO.
4-98 2-18		LFK	San Augustine 22

DISCLAIMER: The use of this standard is governed by the Texas Engineering Practice Act. No warranty of any kind is made by the Texas Department of Transportation for the accuracy, reliability, or completeness of this standard or for incorrect results or damages resulting from its use.

DATE: 11/17/2022 12:53:28 PM
 FILE: T:\LK\KDM\Main\Contract\00.RMC - Routine Maintenance Contracts\123 Plans\6417-38-001 San Augustine MBR\DDN\STANDARD\TRAFFIC\TCP (2-6)-18.dgn

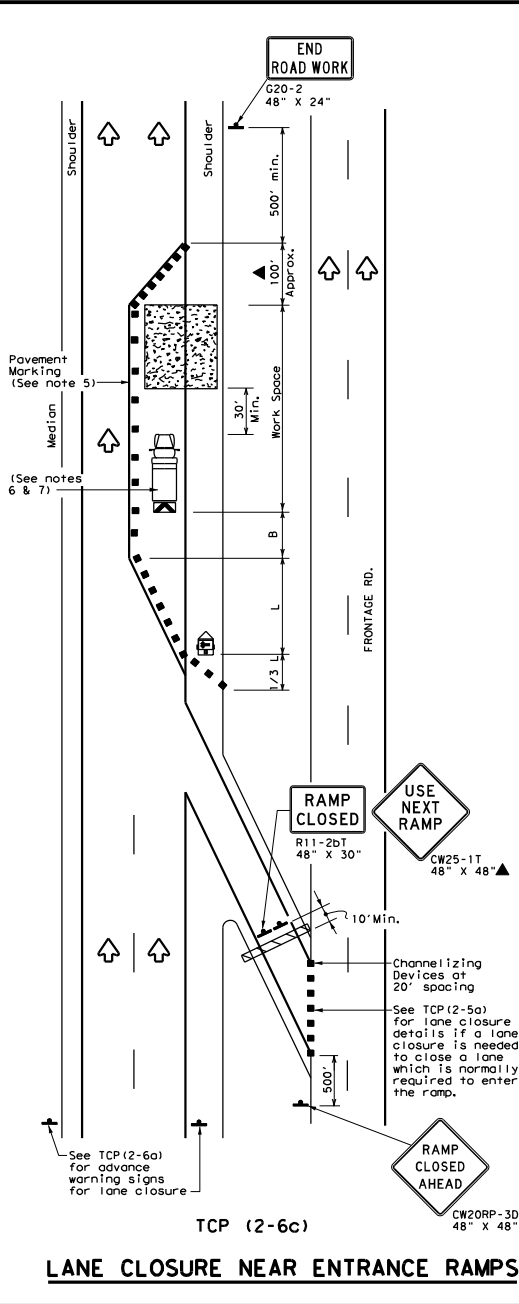
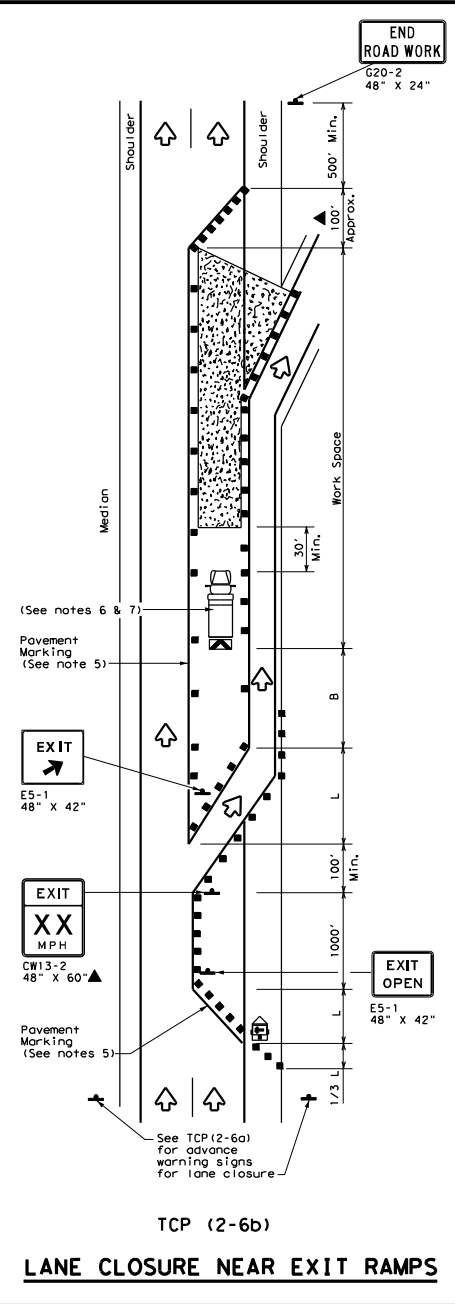
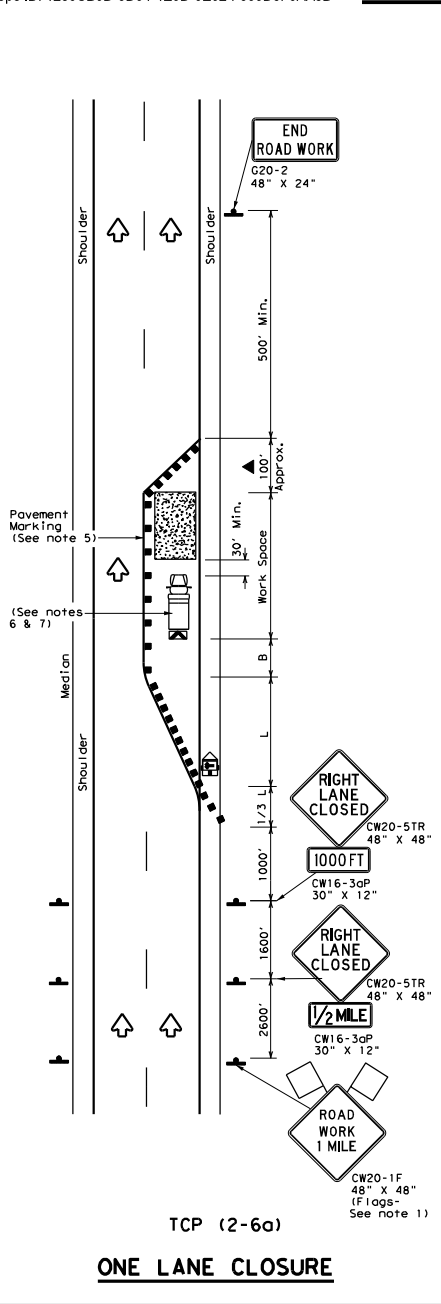

LEGEND			
	Type 3 Barricade		Channelizing Devices
	Heavy Work Vehicle		Truck Mounted Attenuator (TMA)
	Trailer Mounted Flashing Arrow Board		Portable Changeable Message Sign (PCMS)
	Sign		Traffic Flow
	Flag		Flagger

Posted Speed *	Formula	Minimum Desirable Taper Lengths **			Suggested Maximum Spacing of Channelizing Devices		Minimum Sign Spacing ** Distance	Suggested Longitudinal Buffer Space "B"
		10' Offset	11' Offset	12' Offset	On a Taper	On a Tangent		
30	L = WS / 60	150'	165'	180'	30'	60'	120'	90'
35		205'	225'	245'	35'	70'	160'	120'
40		265'	295'	320'	40'	80'	240'	155'
45	L = WS	450'	495'	540'	45'	90'	320'	195'
50		500'	550'	600'	50'	100'	400'	240'
55		550'	605'	660'	55'	110'	500'	295'
60		600'	660'	720'	60'	120'	600'	350'
65		650'	715'	780'	65'	130'	700'	410'
70	700'	770'	840'	70'	140'	800'	475'	
75	750'	825'	900'	75'	150'	900'	540'	

* Conventional Roads Only
 ** Taper lengths have been rounded off.
 L=Length of Taper (FT) W=Width of Offset (FT) S=Posted Speed (MPH)

TYPICAL USAGE				
MOBILE	SHORT DURATION	SHORT TERM STATIONARY	INTERMEDIATE TERM STATIONARY	LONG TERM STATIONARY
			✓	✓

- GENERAL NOTES**
- Flags attached to signs where shown, are REQUIRED.
 - All traffic control devices illustrated are REQUIRED, except those denoted with the triangle symbol may be omitted when stated elsewhere in the plans, or for routine maintenance work, when approved by the Engineer.
 - Channelizing devices used to close lanes may be supplemented with the Chevron Alignment Sign placed on every other channelizing device. Chevrons may be attached to plastic drums as per BC Standards.
 - Channelizing devices used along the work space or along tangent sections may be supplemented with vertical panels (VP) placed on every other channelizing device. If night time conditions make it difficult to see at least two VPs, the VPs may be placed on each channelizing device.
 - The placement of pavement markings may be omitted on intermediate-term stationary work zones with the approval of the Engineer.
 - Shadow Vehicle with TMA and high intensity rotating, flashing, oscillating or strobe lights. Shadow Vehicle with TMA and high intensity rotating, flashing, oscillating or strobe lights. A Shadow Vehicle with a TMA should be used anytime it can be positioned 30 to 100 feet in advance of the area of crew exposure without adversely affecting the performance or quality of the work. If workers are no longer present but road or work conditions require the traffic control to remain in place, Type 3 Barricades or other channelizing devices may be substituted for the Shadow Vehicle and TMA.
 - Additional Shadow Vehicles with TMAs may be positioned in each closed lane, on the shoulder or off the paved surface, next to those shown in order to protect a wider work space.

TRAFFIC CONTROL PLAN
LANE CLOSURES ON
DIVIDED HIGHWAYS
TCP (2-6) - 18

FILE: tcp2-6-18.dgn	DATE: 12/1/2022	BY: LFK	CHECKED: JCB	DATE: 12/1/2022	BY: JCB
© TXDOT December 1985	CONT: 6417	SECT: 38	JOB: 001	US: 96, etc.	HIGHWAY: SHEET NO.
2-94 4-98	6417	38	001	US 96, etc.	
8-95 2-12					
1-97 2-18	LFK		San Augustine		23

[166]

DISCLAIMER: The use of this standard is governed by the "Texas Engineering Practice Act". No warranty of any kind is made by TxDOT for any purpose whatsoever. TxDOT assumes no responsibility for the conversion of units of measurements.

DATE: 11/17/2022 12:54:09 PM
 FILE: T:\LK\KDM\Int\Contracts\0-RMC - Routine Maintenance Contracts\123 of 123\Signage\01-Rumble Strips\WZ (RS) - 22.dgn

Warning sign and rumble strip sequence in opposite direction is same as below.

Flagger to Flagger (Length of Work Area)	ADT	# of Rumble Strip Arrays
1/8 Mile	< 4,500	1
	> 4,500	2
1/4 Mile	< 3,500	1
	> 3,500	2
1/2 Mile	< 2,600	1
	> 2,600	2
1 Mile	< 1,600	1
	> 1,600	2
> 1 Mile	N/A	2

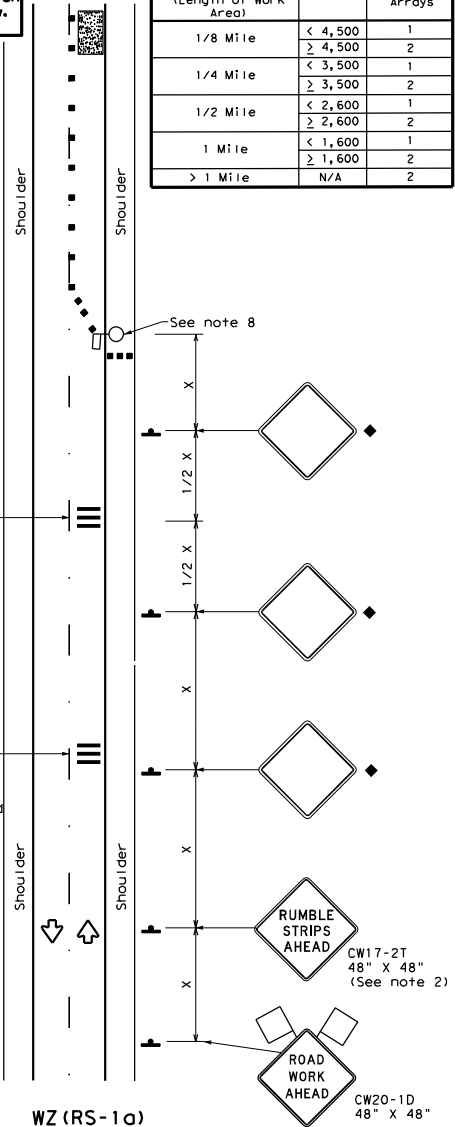

RUMBLE STRIPS ON ONE-LANE TWO-WAY APPLICATION

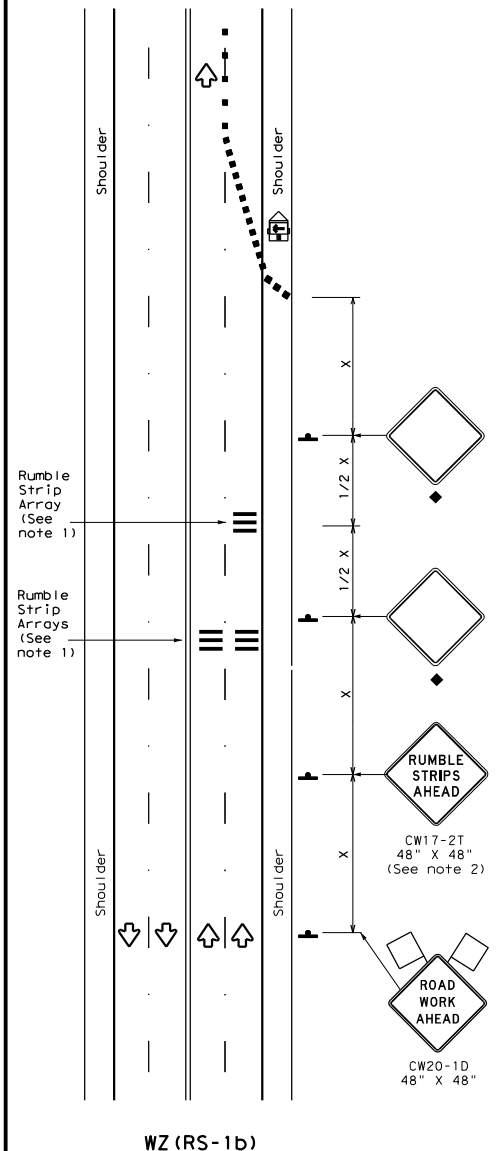

RUMBLE STRIPS FOR LANE CLOSURE ON CONVENTIONAL ROADWAY

GENERAL NOTES

- Each Rumble Strip Array should consist of three rumble strips spaced center to center at the spacing shown in Table 2, placed transverse across the lane at locations shown.
- The CW17-2T "RUMBLE STRIPS AHEAD" sign should be located after the CW20-1D "ROAD WORK AHEAD" sign and spaced as shown. If traffic is observed to be queuing, or is expected to queue beyond the Rumble Strips, the CW17-2T sign and the first Rumble Strip Array may be located upstream of the CW20-1D sign as necessary to provide needed warning.
- Temporary Rumble Strips will be considered subsidiary to Item 502, and shall be a product listed on the Compliant Work Zone Traffic Control Devices.
- Remove Temporary Rumble Strips before removing the advanced warning signs.
- Temporary Rumble Strips should not be used on horizontal curves, loose gravel, soft or bleeding asphalt, heavily rutted pavements or unpaved surfaces.
- Temporary Rumble Strips shall be installed and maintained as per manufacturer's recommendations.
- This standard sheet shall be used in conjunction with other appropriate TCP standard, TMUTCD typical application or project specific detail for the project.
- The one-lane two-way application may utilize a flagger, an Automated Flagger Assistance Device (AFAD) or a Portable Traffic Signal (PTS).
- Replace defective Temporary Rumble Strips as directed by the Engineer.
- Temporary Rumble Strips may be used on freeways or expressways based on engineering judgment and written direction from the Engineer.

Speed	Approximate distance between strips in an array
≤ 40 MPH	10'
> 40 MPH & ≤ 55 MPH	15'
= 60 MPH	20'
≥ 65 MPH	* 35' +

	Type 3 Barricade		Channelizing Devices
	Heavy Work Vehicle		Truck Mounted Attenuator (TMA)
	Trailer Mounted Flashing Arrow Panel		Portable Changeable Message Sign (PCMS)
	Sign		Traffic Flow
	Flag		Flagger

Posted Speed	Formula	Minimum Desirable Taper Lengths			Suggested Maximum Spacing of Channelizing Devices		Minimum Sign Spacing Distance	Suggested Longitudinal Buffer Space
		10' Offset	11' Offset	12' Offset	On a Taper	On a Tangent		
30	L = WS ² / 60	150'	165'	180'	30'	60'	120'	90'
35		205'	225'	245'	35'	70'	160'	120'
40	L = WS	265'	295'	320'	40'	80'	240'	155'
45		450'	495'	540'	45'	90'	320'	195'
50	L = WS	500'	550'	600'	50'	100'	400'	240'
55		550'	605'	660'	55'	110'	500'	295'
60	L = WS	600'	660'	720'	60'	120'	600'	350'
65		650'	715'	780'	65'	130'	700'	410'
70	L = WS	700'	770'	840'	70'	140'	800'	475'
75		750'	825'	900'	75'	150'	900'	540'

* Conventional Roads Only
 ** Taper lengths have been rounded off.
 L=Length of Taper (FT) W=Width of Offset (FT)
 S=Posted Speed (MPH)

MOBILE	SHORT DURATION	SHORT TERM STATIONARY	INTERMEDIATE TERM STATIONARY	LONG TERM STATIONARY
	✓	✓		

◆ Signs are for illustrative purposes only. Signs required may vary depending on the TCP, TMUTCD typical application, or project specific details for the project.

* For posted speeds in excess of 65 MPH, it is recommended that spacing is increased as speed limits increase. Increasing space between rumble strips will improve effectiveness.

				Traffic Safety Division Standard	
<h2>TEMPORARY RUMBLE STRIPS</h2>					
<h3>WZ (RS) - 22</h3>					
FILE:	wzrs22.dgn	DATE:	TxDOT	DATE:	TxDOT
REVISED:	November 2012	COM:	38	JOB:	HIGHWAY
2-14	1-22	BIST:	001	US:	96, etc.
4-16		LFK:	San Augustine	SHEET NO.:	24

DATE: 11/17/2022
 FILE: T:\LFK\DMaint Contracts\0-RMC - Routine Maintenance Contracts\1923 Plans\6417-38-001 San Augustin MBGF\DDN\STANDARD\MBGF STD.MBGF-19.dgn
 DISCLAIMER: This standard is covered by the "Texas Engineering Practice Act". No warranty of any kind is made by TxDOT for any purpose whatsoever. TxDOT assumes no responsibility for the conversion of this standard to other formats or for incorrect results or damages resulting from its use.

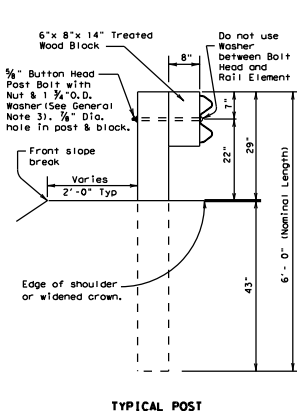

TYPICAL POST

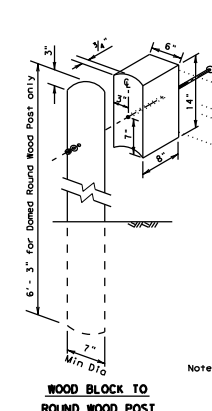

WOOD BLOCK TO ROUND WOOD POST

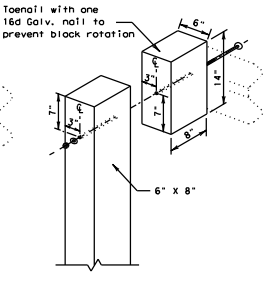

WOOD BLOCK TO RECTANGULAR WOOD POST

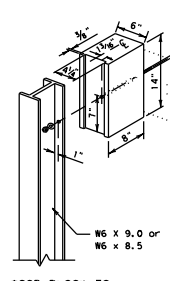

WOOD BLOCK TO STEEL POST

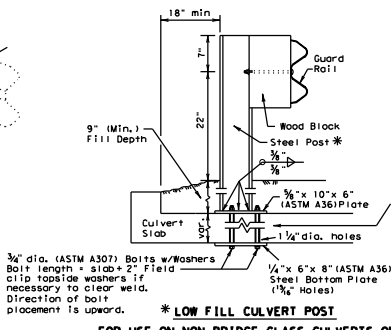

*** LOW FILL CULVERT POST FOR USE ON NON-BRIDGE CLASS CULVERTS ONLY**

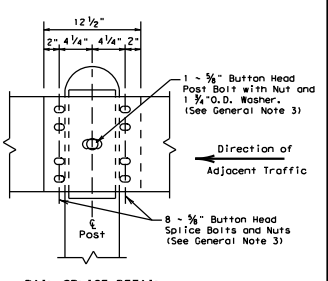
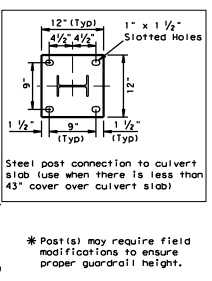

RAIL SPLICE DETAIL

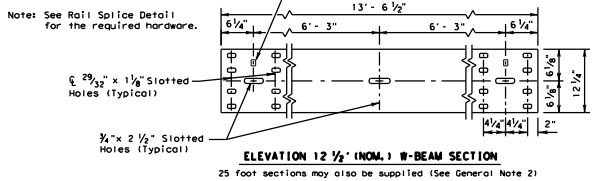

ELEVATION 12 1/2" (NOM.) W-BEAM SECTION
25 foot sections may also be supplied (See General Note 2)

GENERAL NOTES

1. The type of post (round wood post, rectangular wood post, or steel post) will be shown elsewhere in the plans. The exact position of MBGF shall be shown elsewhere in the plans or as directed by the Engineer. Steel posts to be galvanized in accordance with Item 445, "Galvanizing."
2. Rail element shall meet the requirements of Item 540, "Metal Beam Guard Fence" except as modified on the plans. The Contractor may furnish rail elements of 12 1/2 or 25 foot nominal lengths.
3. Button head "post" bolts (ASTM A307) shall be of sufficient length to extend through the full thickness of the nut (ASTM A563) and Type A (1 3/4" O.D.) washer and not more than 1" beyond it. Button head "splice" bolts (ASTM A307) are 7/8" x 1 1/4" (or 2" long of triple rail splices) with a 3/8" double recessed nut (ASTM A563).
4. Fittings (bolts, nuts, and washers) shall be galvanized in accordance with Item 445, "Galvanizing." Fittings shall be subsidiary to the bid item.
5. Crown shall be widened to accommodate the Metal Beam Guard Fence.
6. The lateral approach to the guard fence, shall have a slope rate of not more than 1V:10H.
7. Unless otherwise shown in the plans, guard fence placed in the vicinity of curbs shall be positioned so that the face of curb is located directly below or behind the face of the block. Rail placed over curbs shall be installed so that the post bolt is located approximately 21 inches above the gutter pan or roadway surface.
8. If solid rock is encountered within 0 to 18" of the finished grade, drill a 22" dia. hole, 24" into the rock, or drill two 12" dia. front to back overlapping holes, 24" into the rock. If solid rock is encountered below 18", drill a 12" dia. hole, 12" into the rock or to the standard embedment depth, whichever is less. Any excess post length, after meeting these depths, may be field cut to ensure proper guardrail mounting height. Backfill with a cohesionless material.
9. Posts shall not be set in concrete, of any depth.
10. Special fabrication will be required at installations having a curvature of less than 150 ft. radius.
11. The terminal anchor section (TAS) post shall be set in Class A concrete (unless otherwise shown in the plans) in accordance with Item 421, "Hydraulic Cement Concrete." Concrete shall be subsidiary to the bid item requiring construction of the terminal anchor section (TAS). Terminal anchor post to be galvanized in accordance with Item 445, "Galvanizing."
12. Unless otherwise shown in the plans, a composite material post and/or block that meets the requirements of DMS-7210, "Composite Material Posts and Blocks for Metal Beam Guard Fence" may be substituted for posts and/or blocks of similar dimensions. The Construction Division, TxDOT maintains a Material Producer List (MPL) for producers of materials conforming to DMS-7210. Only producers on the MPL can furnish composite material posts and/or blocks.

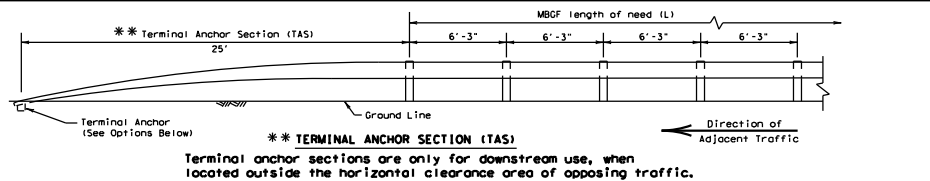

**** TERMINAL ANCHOR SECTION (TAS)**

Terminal anchor sections are only for downstream use, when located outside the horizontal clearance area of opposing traffic.

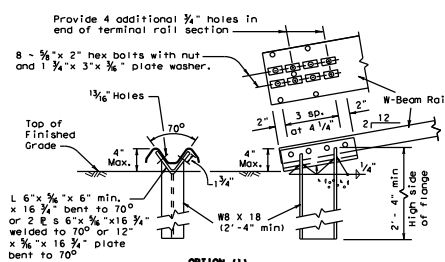

OPTION 11

Note: This anchor post requires four additional 3/4 inch holes (shop or field) in the rail member with eight 3/4 inch hex bolts with nut and plate washer.

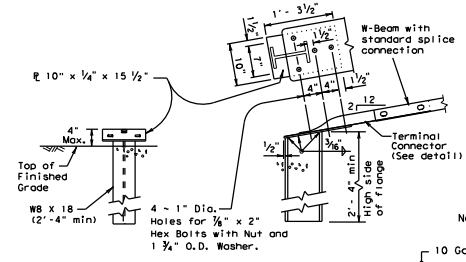

OPTION 12

Note: This anchor post requires the use of the 10 ga. terminal connector with four 7/8 inch hex bolts with nut and washer.

TERMINAL ANCHOR POST OPTIONS
(See General Note 11)

Notes:
 Either concrete anchor may be used with either post option above.
 No construction joint is allowed in the concrete anchor.
 Terminal rail may be bolted to post and in twist position prior to placing concrete anchor.
 If concrete anchor is precast, the area should be compacted as directed by the Engineer, when placed in the field.

TERMINAL CONCRETE ANCHOR OPTIONS
(See General Note 11)

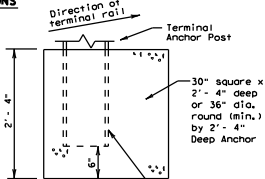
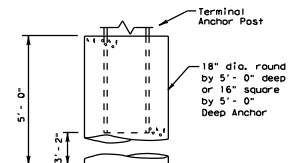

Place face of post approx. on center of anchor

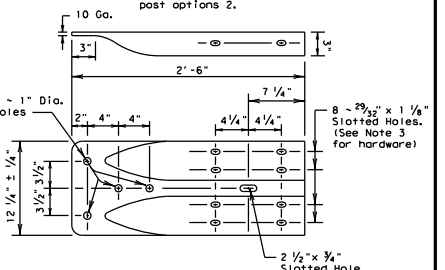

TERMINAL CONNECTOR

For connection hardware to concrete rails, see the MBGF transition standards.

ONLY FOR USE IN MAINTENANCE REPAIRS OR HIGHLY CONSTRAINED SITE CONDITIONS.

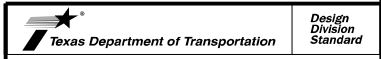

METAL BEAM GUARD FENCE

MBGF - 19

FILE: mdfg19.dgn	DN: TxDOT	CK: KM	DN: BD	CK: VP
REVISIONS	CONT	SECT	JOB	HIGHWAY
6417	38	001	US 96, etc.	
DIST	COUNTY			SHEET NO.
LFK	San Augustine			25

DISCUSS MBGF WITH DESIGNER. THIS STANDARD IS COVERED BY THE "TEXAS ENGINEERING PRACTICE ACT." NO WARRANTY OF ANY KIND IS MADE BY TxDOT FOR ANY PURPOSE WHATSOEVER. TxDOT ASSUMES NO RESPONSIBILITY FOR THE CONVERSION OF THIS STANDARD TO OTHER FORMATS OR FOR INCORRECT RESULTS OR DAMAGES RESULTING FROM ITS USE.

DATE: 11/17/2022
 FILE: T:\LEFKOWIA\Contract\0-RMC - Routine Maintenance Contracts\17-38-001 San Augustine MBGF\DDN\STANDARD\MBGF STD\MBGF (SR) -19.dgn

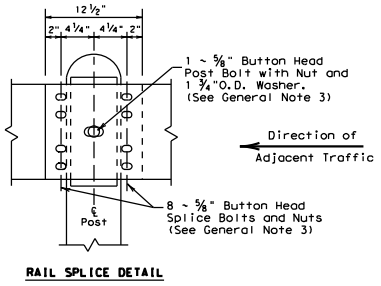
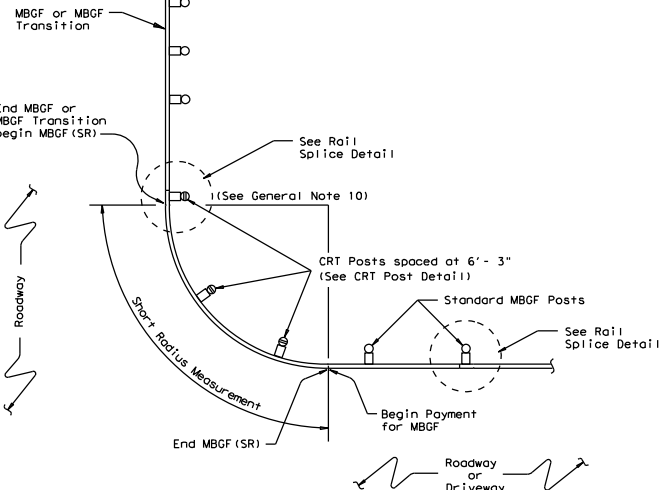
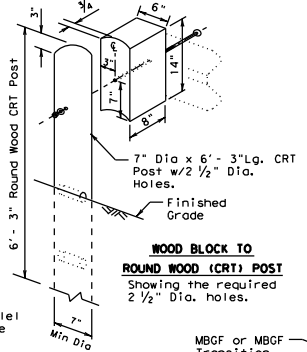
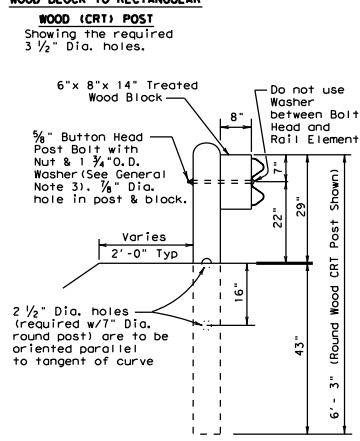
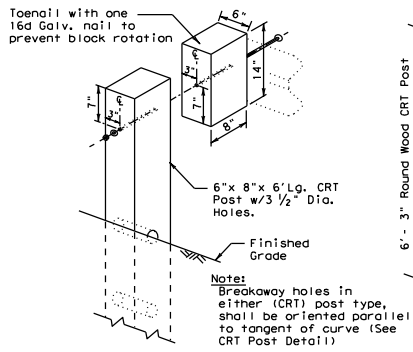

GENERAL NOTES

- The type of (CRT) post (round wood post, or rectangular wood post) will be shown elsewhere in the plans. The exact position of MBGF shall be shown elsewhere in the plans or as directed by the Engineer.
- Steel posts are not permitted at CRT post positions.
- Rail element shall meet the requirements of Item 540, "Metal Beam Guard Fence" except as modified on the plans. The Contractor may furnish rail elements of 12 1/2 or 25 foot nominal lengths.
- Button head "post" bolts (ASTM A307) shall be of sufficient length to extend through the full thickness of the nut (ASTM A563) and Type A (1 3/4" O.D.) washer and not more than 1" beyond it. Button head "splice" bolts (ASTM A307) are 5/8" x 1 1/4" (or 2" long at triple rail splices) with a 5/8" double recessed nut (ASTM A563).
- Fittings (bolts, nuts, and washers) shall be galvanized in accordance with Item 445, "Galvanizing." Fittings shall be subsidiary to the bid item.
- Crown shall be widened to accommodate the Metal Beam Guard Fence.
- The lateral approach to the guard fence, shall have a slope rate of not more than 1V:10H.
- Unless otherwise shown in the plans, guard fence placed in the vicinity of curbs shall be positioned so that the face of curb is located directly below or behind the face of the block. Rail placed over curbs shall be installed so that the post bolt is located approximately 21 inches above the gutter pan or roadway surface.
- If solid rock is encountered within 0 to 18" of the finished grade, drill a 22" dia. hole, 24" into the rock, or drill two 12" dia. front to back overlapping holes, 24" into the rock. If solid rock is encountered below 18", drill a 12" dia. hole, 12" into the rock or to the standard embedment depth, whichever is less. Any excess post length, after meeting these depths, may be field cut to ensure proper guardrail mounting height. Backfill with a cohesionless material.
- Guardrail posts shall not be set in concrete, of any depth.
- Special rail fabrication will be required at installations having a curvature of less than 150 ft. radius. The required radius shall be shown on the plans.
- The terminal anchor section (TAS) post shall be set in Class A concrete (unless otherwise shown in the plans) in accordance with Item 421, "Hydraulic Cement Concrete." Concrete shall be subsidiary to the bid item requiring construction of the terminal anchor section (TAS). Terminal anchor post to be galvanized in accordance with Item 445, "Galvanizing."
- Unless otherwise shown in the plans, a composite material post and/or block that meets the requirements of DMS-7210, "Composite Material Posts and Blocks for Metal Beam Guard Fence" may be substituted for posts and/or blocks of similar dimensions. The Construction Division, TxDOT maintains a Material Producer List (MPL) for producers of materials conforming to DMS-7210. Only producers on the MPL can furnish composite material posts and/or blocks.

(CRT) POST DETAIL CONTROLLED RELEASE TERMINAL POST

Two or more wood CRT post(s) are required at any radius installation located at intersecting roadways or driveways.

"DRIVEWAY" TERMINAL ANCHOR SECTION

Only for use within driveway locations, where a standard (TAS) Terminal Anchor Section can not be installed.

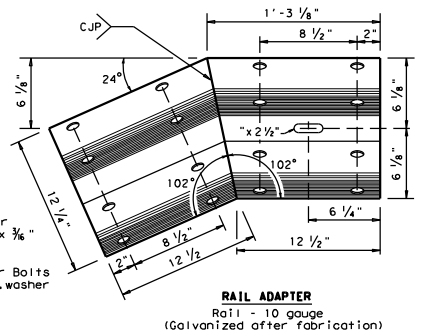
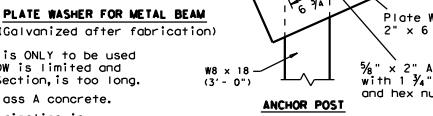
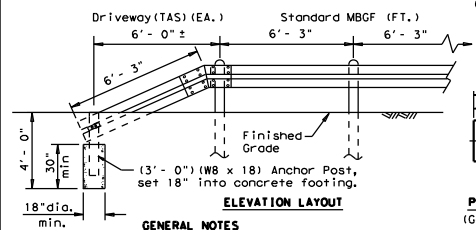

ONLY FOR USE IN MAINTENANCE REPAIRS OR HIGHLY CONSTRAINED SITE CONDITIONS.

Texas Department of Transportation
Design Division Standard

METAL BEAM GUARD FENCE (SHORT RADIUS) MBGF (SR) - 19

FILE: mbgfr19.dgn	DN: TxDOT	CR: KM	DN: BD	CR: VP
© TxDOT NOVEMBER 2019	CONT	SECT	JOB	HIGHWAY
REVISIONS	6417	38	001	US 96, etc.
	DIST	COUNTY		SHEET NO.
	LFK	San Augustine		26

DISCUSS IFCR
 THIS STANDARD IS COVERED BY THE "TEXAS ENGINEERING PRACTICE ACT" - NO WARRANTY OF ANY KIND IS MADE BY TxDOT FOR ANY PURPOSE WHATSOEVER
 TxDOT ASSUMES NO RESPONSIBILITY FOR THE CONVERSION OF THIS STANDARD TO OTHER FORMATS OR FOR INCORRECT RESULTS OR DAMAGES RESULTING FROM ITS USE.
 DATE: 11/17/2022
 FILE: T:\LFK\DM\Main\ Contracts\0-RMC - Routine Maintenance Contracts\123 Plans\6417-38-001 San Augustine MBGF\DDN\STANDARD\MBGF STD\MBGF (T101)-19.dgn

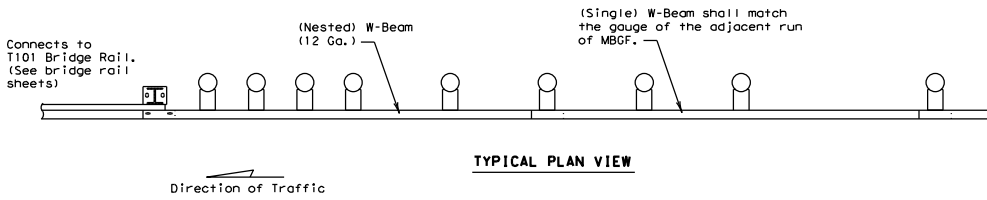

TYPICAL PLAN VIEW

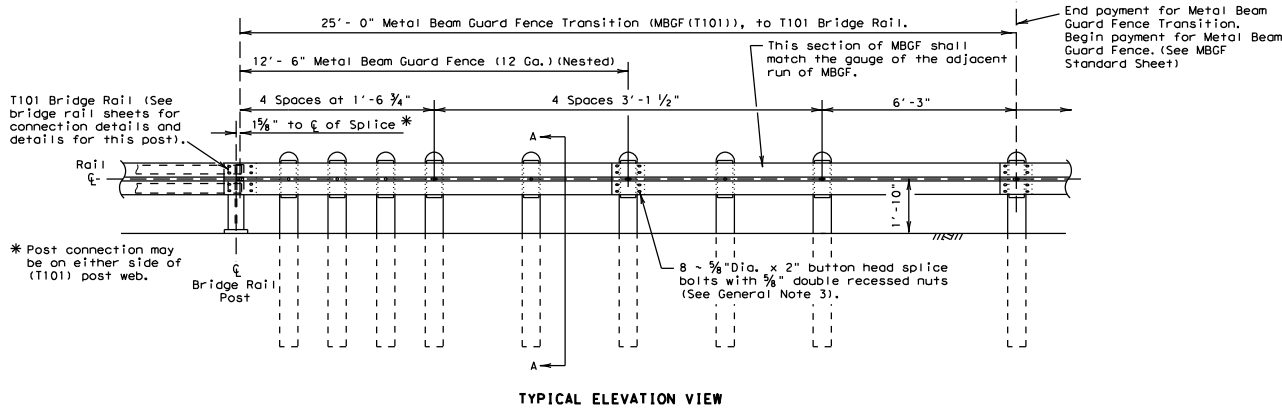

TYPICAL ELEVATION VIEW

* Post connection may be on either side of (T101) post web.

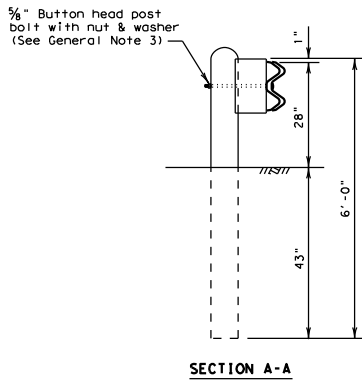

SECTION A-A

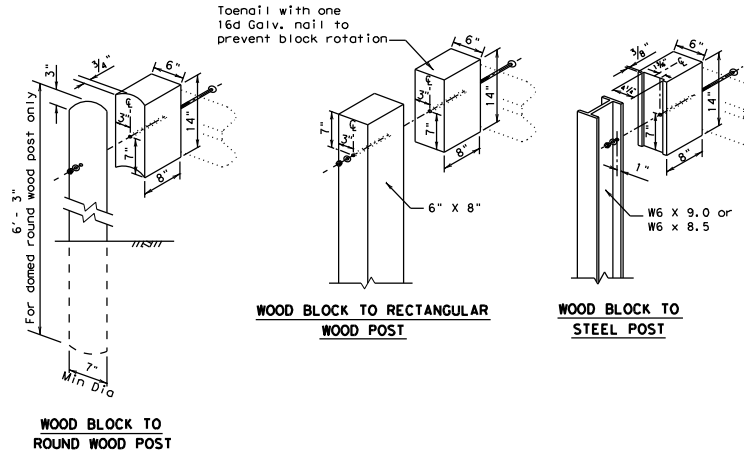

WOOD BLOCK TO RECTANGULAR WOOD POST

WOOD BLOCK TO STEEL POST

GENERAL NOTES

- The type of post (round wood post, rectangular wood post, or steel post) will be shown elsewhere in the plans. The exact position of transitions shall be shown elsewhere in the plans or as directed by the Engineer.
- Rail element shall meet the requirements of Item 540, "Metal Beam Guard Fence" except as modified on the plans.
- Button head "post" bolts (ASTM A307) shall be of sufficient length to extend through the full thickness of the nut (ASTM A563) and the Type A 1 1/4" O.D. washer and not more than 1" beyond it. Button head "splice" bolts (ASTM A307) are 5/8" x 2" (at triple rail splices) with a 3/8" double recessed nuts (ASTM A563).
- Fittings (bolts, nuts, and washers) shall be galvanized in accordance with Item 445, "Galvanizing." Fittings shall be subsidiary to the bid item requiring construction of the transition.
- Crown will be widened to accommodate transitions.
- If solid rock is encountered. See the MBGF standard sheet for proper installation guidance.
- Posts shall not be set in concrete.
- Unless otherwise shown in the plans, a composite material post and/or block that meets the requirements of DMS-7210, "Composite Material Posts and Blocks for Metal Beam Guard Fence" may be substituted for posts and/or blocks of similar dimensions. The Construction Division, TxDOT, maintains a Material Producer List (MPL) for producers of materials conforming to DMS-7210. Only producers on the MPL can furnish composite material posts and/or blocks.
- Refer to MBGF Standard Sheet for additional details.

ONLY FOR USE IN MAINTENANCE REPAIRS.

Texas Department of Transportation Design Division Standard			
METAL BEAM GUARD FENCE TRANSITION (T101) (T101 BRIDGE RAIL) MBGF (T101)-19			
FILE: mbgf10119.dgn	DN: TxDOT	CR: KM	DR: BD
© TxDOT NOVEMBER 2019	CONT SECT	JOB	HIGHWAY
REVISIONS	6417 38	001	US 96, etc.
	DIST	COUNTY	SHEET NO.
	LFK	San Augustine	27

DISCUSS MGF TR - 19 WITH THE DESIGNER PRIOR TO CONSTRUCTION. THIS STANDARD IS COVERED BY THE "TEXAS ENGINEERING PRACTICE ACT". NO WARRANTY OF ANY KIND IS MADE BY TxDOT FOR ANY PURPOSE WHATSOEVER. TxDOT ASSUMES NO RESPONSIBILITY FOR THE CONVERSION OF THIS STANDARD TO OTHER FORMATS OR FOR INCORRECT RESULTS OR DAMAGES RESULTING FROM ITS USE.

DATE: 11/17/2022 FILE: TR-19\KDM\mgftr-19.dgn

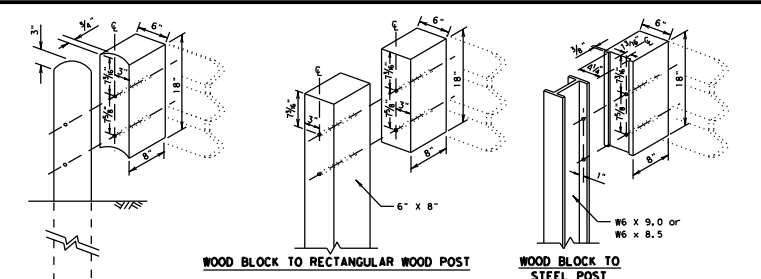
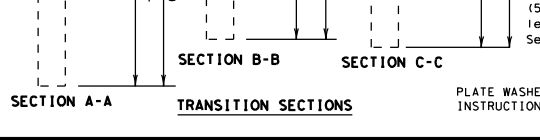
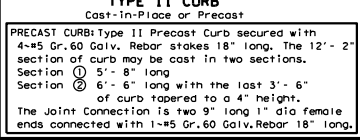
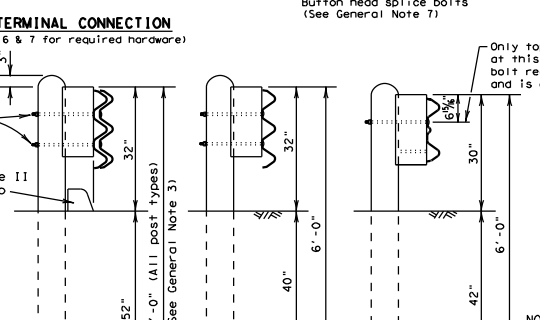
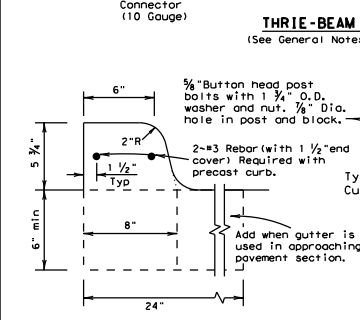
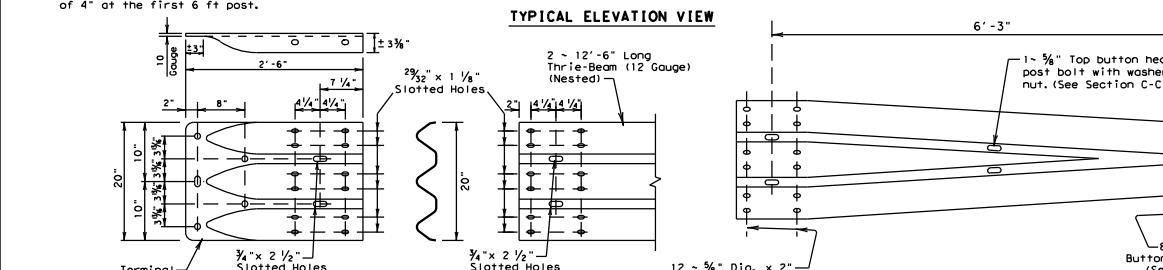
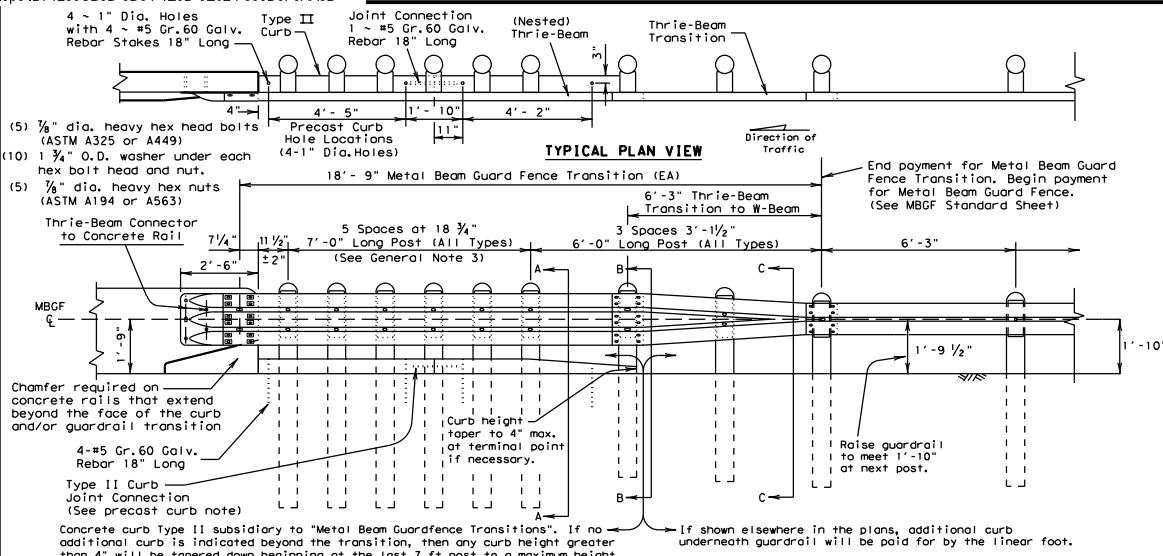

- GENERAL NOTES**
- Concrete curb may be cast-in-place or precast as shown on this sheet. When used in conjunction with thrie-beam guard fence transitions, curb shall be Type II (Typically 5 3/4" height above surface; See CCCC standard sheet) unless otherwise shown in the plans. If other curb heights are shown in the plans in conjunction with the transition, the concrete curb shall be from 4" to 8" with a relatively vertical face. Concrete curb shall be continuous to the seventh post.
 - Contact the Design Division for drainage cut options needed within the curb section of the transition.
 - The type of post (round wood, rectangular wood or steel) will be shown elsewhere in the plans.
 - The post length shall be marked on all 7'-0" long posts by the Manufacturer. The mark shall be located within the top 1 ft. region of the post, at least 3/8" in height, and visible after installation. Wooden posts shall be marked with a brand, and steel posts with a stencil before galvanizing.
 - Rail element shall meet the requirements of Item 540, "Metal Beam Guard Fence" except as modified on the plans. The thrie-beam terminal connector and the thrie-beam transition to w-beam shall be of the same material, but shall not be less than 10 gauge.
 - Contractor shall verify that the locations of bolt holes match those in the thrie-beam terminal connector prior to ordering materials.
 - Unless otherwise shown in the plans, transitions shall be placed with the block face in front of or directly above the curb face.
 - Install terminal connector with (12) rectangular guardrail plate washers (FWR03) and (12) 3/8" x 2" button head splice bolts with recessed nuts.
 - Button head "post bolts & nuts" shall meet the requirements of (ASTM A307), and shall be of sufficient length to extend through the full thickness of the nut and 3/8" washer (FWC160) and not more than 1" beyond it. Trim remaining bolt length to meet required length.
 - Fittings (bolts, nuts, and washers) shall be galvanized in accordance with Item 445, "Galvanizing". Fittings shall be subsidiary to the bid item.
 - Crown shall be widened to accommodate transitions.
 - If solid rock is encountered. See the MGF standard sheet for the proper installation guidance.
 - Posts shall not be set in concrete.
 - Unless otherwise shown in the plans, a composite material post and/or block that meets the requirements of DMS-7210, "Composite Material Posts and Blocks for Metal Beam Guard Fence" may be substituted for posts and/or blocks of similar dimensions. The Construction Division, TxDOT, maintains a Material Producer List (MPL) for producers of materials conforming to DMS-7210. Only producers on the MPL can furnish composite material posts and/or blocks.

NOTES:

(5) 3/8" dia. heavy hex bolts, length will vary depending on width of concrete rail, leave 1" of bolt length past the 3/8" hex nut. Trim as required. See General Notes 6 & 7 for additional connection details.

BRIDGE APPROACH - UPSTREAM: THE NESTED RAIL LAPS OVER THE TERMINAL CONNECTOR. PLATE WASHERS ARE INSTALLED UNDER THE SPLICE NUTS AGAINST INSIDE OF CONNECTOR.

BRIDGE EXIT - DOWNSTREAM: THE TERMINAL CONNECTOR LAPS OVER THE NESTED RAIL. PLATE WASHERS ARE INSTALLED UNDER THE BOLT HEAD AGAINST OUTSIDE OF CONNECTOR.

ONLY FOR USE IN MAINTENANCE REPAIRS.

Texas Department of Transportation
 Design Division Standard

METAL BEAM GUARD FENCE TRANSITION (THRIE-BEAM TRANSITION) MGF (TR) - 19

FILE: mbgtr19.dgn	DN: TxDOT	CR: KM	DN: BD	CR: VP
© TxDOT NOVEMBER 2019	CONF: SECT	JOB: HIGHWAY		
REVISIONS	641738	001	US 96, etc.	
DIST	COUNTY	SHEET NO.		
LFK	San Augustine	28		

DATE: 11/17/2022
 FILE: T:\LFDK\Wgint\ Contracts\0-RMC - Routine Maintenance Contracts\17-38-001 San Augustin MBGF\00N\STANDARD-GUARD FENCE STD.GF (31)-19.dgn
 DISCUSS W/CR: THIS STANDARD IS COVERED BY THE TEXAS ENGINEERING PRACTICE ACT. NO WARRANTY OF ANY KIND IS MADE BY TXDOT FOR ANY PURPOSE WHATSOEVER. TXDOT ASSUMES NO RESPONSIBILITY FOR THE CONVERSION OF THIS STANDARD TO OTHER FORMATS OR FOR INCORRECT RESULTS OR DAMAGES RESULTING FROM ITS USE.

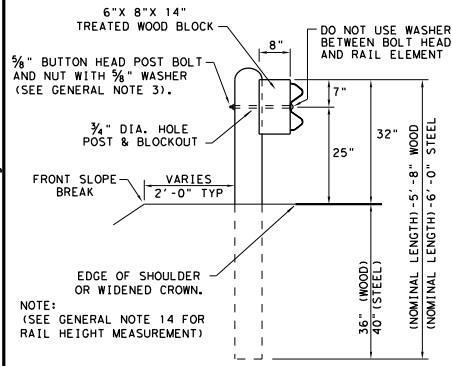

TYPICAL POST PLACEMENT

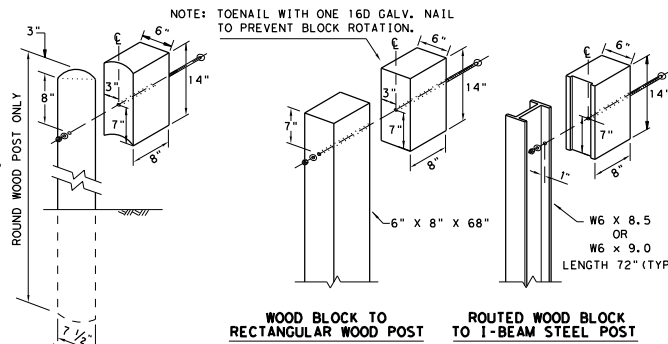

WOOD BLOCK TO ROUND WOOD POST

NOTE: ** "WOOD" INDICATES DIMENSIONS FOR BOTH ROUND AND RECTANGULAR WOOD POST SYSTEMS.

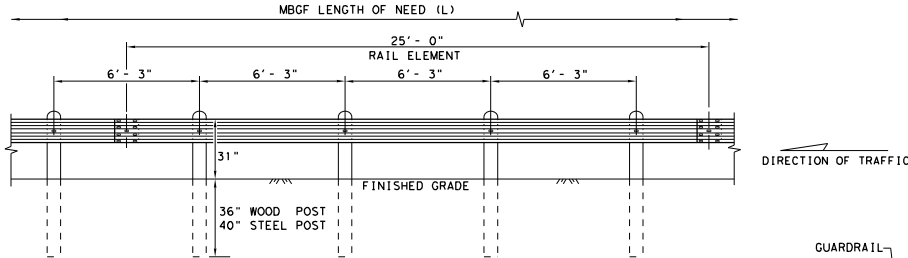

ELEVATION MID-SPAN RAIL SPLICE

SHOWING A 25' - 0" SECTION OF W-BEAM RAIL. (SEE GENERAL NOTE 2)

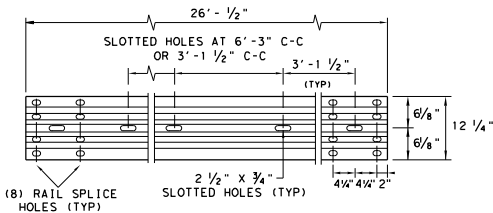

ELEVATION 25' - 0" (NOM.) W-BEAM SECTION

NOTES: SEE GENERAL NOTE 2 FOR ALLOWABLE RAIL TYPES. SEE RAIL SPLICE DETAIL FOR REQUIRED HARDWARE.

NOTE: FOUR TYPES OF BUTTON-HEAD GUARD RAIL BOLTS COME WITH A RECESSED NUT.

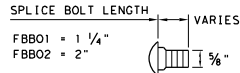

BUTTON HEAD BOLT

NOTE: SEE GENERAL NOTE 3 FOR SPLICE & POST BOLT DETAILS.

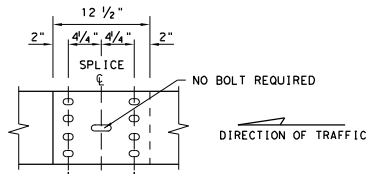

MID-SPAN RAIL SPLICE DETAIL

NOTE: GF (31)1, MID-SPAN RAIL SPLICES ARE REQUIRED WITH 6'-3" POST SPACINGS.

* POST(S) MAY REQUIRE FIELD MODIFICATION TO ENSURE PROPER GUARDRAIL HEIGHT.

12" x 12" x 1/4" (ASTM A36) STEEL BOTTOM PLATE WITH 1" DIA. HOLES REQUIRED WITH BOLT-THROUGH INSTALLATION.

LOW FILL CULVERT POST

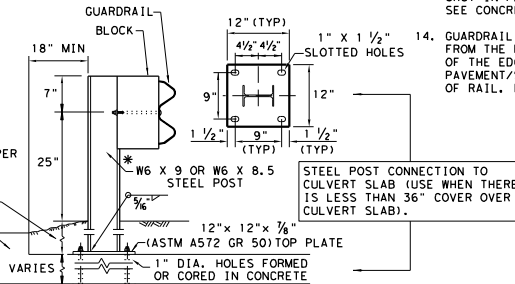

NOTE: TWO INSTALLATION OPTIONS.

1. BOLT-THROUGH OPTION: REQUIRES A 6" MIN. SLAB THICKNESS. 3/8" DIA (ASTM A449) HEAVY HEX BOLTS WITH TWO HARDENED WASHER EACH AND HEAVY HEX NUTS.
NOTE: BOLT LENGTH = SLAB PLUS 2 1/4" MIN.

2. EPOXY ANCHOR OPTION: THIS OPTION MAY ONLY BE USED IF THE CULVERT SLAB IS 9" MIN. THICK. THREADED ANCHOR RODS MUST BE 3/8" DIA. ASTM A449 OR A193 GRADE B7 WITH HEAVY HEX NUT, AND ONE HARDENED WASHER EACH. EMBED ANCHOR RODS 6" WITH HILTI HIT RE 500 EPOXY ADHESIVE. OTHER TYPE III CLASS C EPOXY ADHESIVES MEETING THE REQUIREMENTS OF DMS-6100, "EPOXIES AND ADHESIVES", MAY BE USED IF IT CAN BE DEMONSTRATED THAT THEY MEET OR EXCEED THE STRENGTH OF HILTI HIT RE 500 WITH THE SAME EMBEDMENT DEPTH AND THREADED ROD DIA. FOLLOW THE MANUFACTURER'S REQUIREMENTS FOR INSTALLING EPOXIED THREADED RODS. EXTEND RODS 1/4" MIN. BEYOND NUT.

NOTE: CULVERTS OF 25 FT. OR LESS, SEE GF (31)1S STANDARD FOR "LONG SPAN" OPTION.

GENERAL NOTES

- THE TYPE OF POST (ROUND WOOD POST, RECTANGULAR WOOD POST, OR STEEL POST) WILL BE AS SHOWN IN THE PLANS. THE EXACT POSITION OF MBGF SHALL BE SHOWN IN THE PLANS OR AS DIRECTED BY THE ENGINEER. STEEL POSTS TO BE GALVANIZED IN ACCORDANCE WITH ITEM 445, "GALVANIZING."
- RAIL ELEMENTS SHALL MEET THE REQUIREMENTS OF ITEM 540, "METAL BEAM GUARD FENCE" EXCEPT AS MODIFIED IN THE PLANS. THE CONTRACTOR MAY FURNISH RAIL ELEMENTS OF 25' - 0", OR 12' - 6" (NOM.) LENGTHS. RAIL ELEMENTS MAY HAVE SLOTTED HOLES AT 3'-1 1/2" C-C OR 6'-3" C-C. A SPECIAL LENGTH OF RAIL MAY BE MANUFACTURED TO ACCOMMODATE THE DOWNSTREAM ANCHOR TERMINAL (DAT) AND THE TRANSITION SECTIONS OF GUARDRAIL.
- BUTTON HEAD "POST BOLTS & NUTS" SHALL MEET THE REQUIREMENTS OF (ASTM A307), AND SHALL BE OF SUFFICIENT LENGTH TO EXTEND THROUGH THE FULL THICKNESS OF THE NUT AND 3/8" WASHER (FWC160) AND NOT MORE THAN 1" BEYOND IT. TRIM REMAINING BOLT LENGTH TO MEET REQUIRED LENGTH.
- FITTINGS (BOLTS, NUTS, AND WASHERS) SHALL BE GALVANIZED IN ACCORDANCE WITH ITEM 445, "GALVANIZING." FITTINGS SHALL BE SUBSIDIARY TO THE BID ITEM.
- CROWN SHALL BE WIDENED TO ACCOMMODATE THE METAL BEAM GUARD FENCE.
- THE LATERAL APPROACH TO THE GUARD FENCE, SHALL HAVE A MAXIMUM SLOPE OF 1V:10H.
- IF SHOWN ELSEWHERE IN THE PLANS OR AS DIRECTED BY THE ENGINEER, THE GUARD FENCE MAY BE FLARED AT A RATE OF 25:1 OR FLATTER.
- UNLESS OTHERWISE SHOWN IN THE PLANS, GUARD FENCE PLACED IN THE VICINITY OF CURBS SHALL BE POSITIONED SO THAT THE FACE OF CURB IS LOCATED DIRECTLY BELOW OR BEHIND THE FACE OF THE RAIL. RAIL PLACED OVER CURBS SHALL BE INSTALLED SO THAT THE POST BOLT IS LOCATED APPROXIMATELY 25 INCHES ABOVE THE GUTTER PAN OR EDGE OF SHOULDER.
- APPLICATIONS IN SOLID ROCK ARE ONLY ALLOWED WITH STEEL POSTS. IF SOLID ROCK IS ENCOUNTERED WITHIN 0 TO 18" OF THE FINISHED GRADE, DRILL A 24" DIA. HOLE, 24" INTO THE ROCK. IF SOLID ROCK IS ENCOUNTERED BELOW 18", DRILL A 12" DIA. HOLE, 12" INTO THE ROCK OR TO THE STANDARD EMBEDMENT DEPTH, WHICHEVER MAYBE LESS. ANY EXCESS POST LENGTH, AFTER MEETING THESE DEPTHS, MAY BE FIELD CUT TO ENSURE PROPER GUARDRAIL MOUNTING HEIGHT. BACKFILL WITH COARSE AGGREGATE MATERIAL.
- POSTS SHALL NOT BE SET IN CONCRETE, OF ANY DEPTH.
- SPECIAL FABRICATION WILL BE REQUIRED AT INSTALLATION LOCATIONS HAVING A CURVATURE OF LESS THAN 150 FT. RADIUS.
- UNLESS OTHERWISE SHOWN IN THE PLANS, A COMPOSITE MATERIAL BLOCK THAT MEETS THE REQUIREMENTS OF DMS-7210, "COMPOSITE MATERIAL POSTS AND BLOCKS FOR METAL BEAM GUARD FENCE" MAY BE SUBSTITUTED FOR BLOCKS OF SIMILAR DIMENSIONS. THE CONSTRUCTION DIVISION, TXDOT MAINTAINS A MATERIAL PRODUCER LIST (MPL) FOR PRODUCERS OF MATERIALS CONFORMING TO DMS-7210 ONLY PRODUCERS ON THE MPL MAY FURNISH COMPOSITE MATERIAL BLOCKS.
- FOR THE LOW FILL CULVERT OPTION, POSTS LOCATED PARTIALLY OR WHOLLY BETWEEN PRECAST BOX CULVERT UNITS, THE USE OF A CAST-IN-PLACE CONCRETE CLOSURE BETWEEN BOXES IS REQUIRED. THE LENGTH OF THE CAST-IN-PLACE CONCRETE CLOSURE SHALL ACCOMMODATE THE PLACEMENT OF THE LOW FILL CULVERT OPTION. SEE CONCRETE CLOSURE DETAILS ON BRIDGE STANDARD SCP-MD.
- GUARDRAIL HEIGHT MEASUREMENT: WHEN THE GUARDRAIL IS LOCATED ABOVE PAVEMENT, MEASURE THE HEIGHT FROM THE PAVEMENT TO THE TOP OF THE W-BEAM RAIL. WHEN THE GUARDRAIL IS LOCATED UP TO 2 FT. OFF OF THE EDGE OF PAVEMENT OR FOR A PAVEMENT OVERLAY, USE A 10-FOOT STRAIGHTEDGE TO EXTEND THE PAVEMENT/SHOULDER SLOPE TO THE BACK OF RAIL, MEASURE FROM THE BOTTOM OF STRAIGHTEDGE TO THE TOP OF RAIL. FOR GUARDRAIL LOCATED DOWN A 10:1 SLOPE, MEASURE FROM THE NOMINAL TERRAIN.

		Design Division Standard	
METAL BEAM GUARD FENCE TL-3 MASH COMPLIANT GF (31)-19			
FILE: gf3119.dgn	DN: TXDOT	CR: KM	DR: VP
REV: NOVEMBER 2019	CONT: 38	SECT: 001	JOB: US 96, etc.
DIST: LFK		COUNTY: San Augustine	SHEET NO: 29

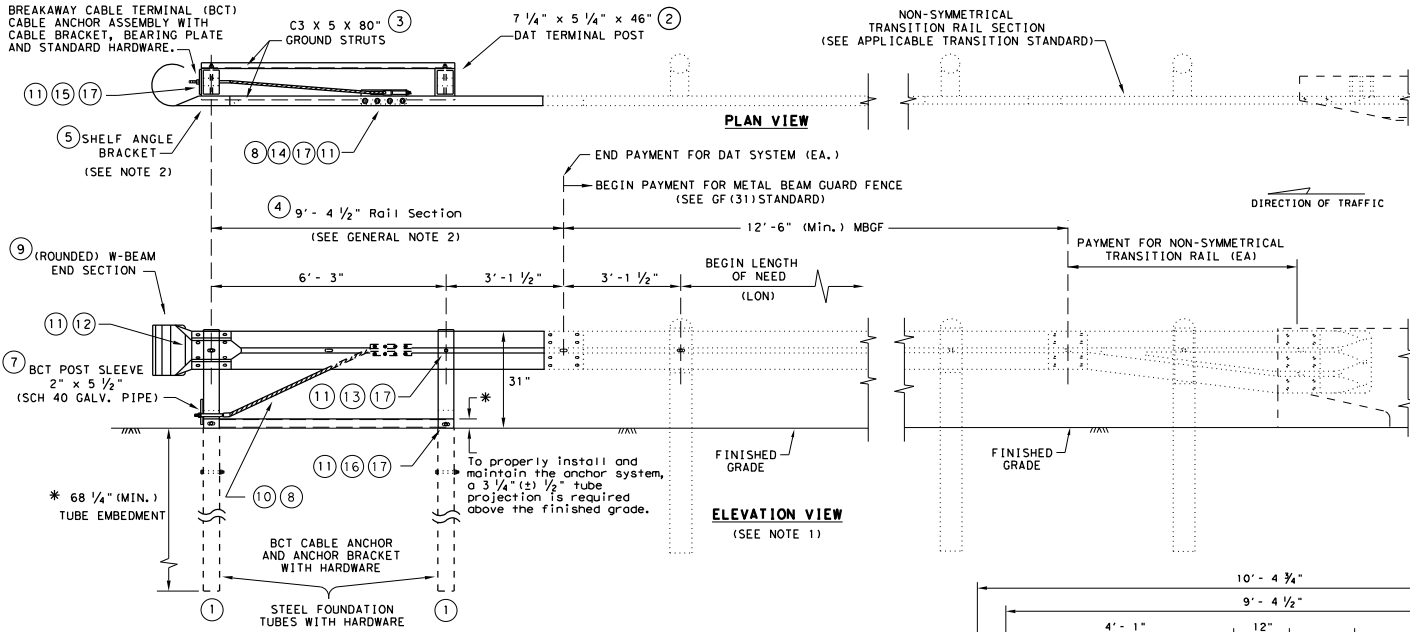

GENERAL NOTES

1. THE DETAIL SHOWN IS THE MINIMUM LENGTH OF NEED (LON) FOR A DOWNSTREAM ANCHOR TERMINAL (DAT) CONNECTED TO A CONCRETE RAIL.
2. THE RAIL SECTION AT THE END POST IS SUPPORTED BY THE SHELF ANGLE BRACKET. THE RAIL ELEMENT IS NOT ATTACHED TO THE END POST.
3. THE FOUNDATION TUBES SHALL NOT PROJECT MORE THAN 3 3/4" ABOVE THE FINISHED GRADE.
4. ALL HARDWARE FOR DAT SHALL BE ASTM A307 UNLESS OTHERWISE SHOWN.
5. REFER TO GF (31) SHEET FOR TERMINAL CONNECTION DETAILS.

MOW STRIP INSTALLATION

IF A MOW STRIP IS REQUIRED WITH THE DAT INSTALLATION THE LEAVE-OUT AREA AROUND THE STEEL FOUNDATION TUBES AND THE TWO CHANNEL STRUTS MAY BE OMITTED. THIS WILL REQUIRE A FULL POUR AT THE FOUNDATION TUBES.

DOWNSTREAM ANCHOR TERMINAL (DAT)

NOTE: ONLY FOR DOWNSTREAM USE, WHEN LOCATED OUTSIDE THE HORIZONTAL CLEARANCE AREA OF OPPOSING TRAFFIC.

#	(DAT) PARTS LIST	QTY
1	STEEL FOUNDATION TUBE	2
2	DAT TERMINAL POST	2
3	CHANNEL STRUT	2
4	TERMINAL RAIL ELEMENT	1
5	SHELF ANGLE BRACKET	1
6	BCT BEARING PLATE	1
7	BCT POST SLEEVE	1
8	GUARDRAIL ANCHOR BRACKET	1
9	(ROUNDED) W-BEAM END SECTION	1
10	BCT CABLE ANCHOR	1
11	RECESSED NUT, GUARDRAIL	20
12	1 1/4" BUTTON HEAD BOLT	4
13	10" BUTTON HEAD BOLT	2
14	5/8" x 2" HEX HEAD BOLT	8
15	5/8" x 8" HEX HEAD BOLT	4
16	5/8" x 10" HEX HEAD BOLT	2
17	5/8" FLAT WASHER	18

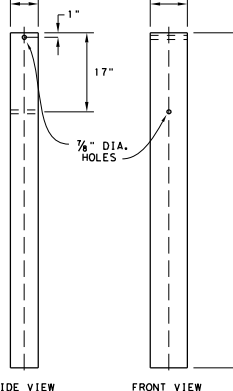
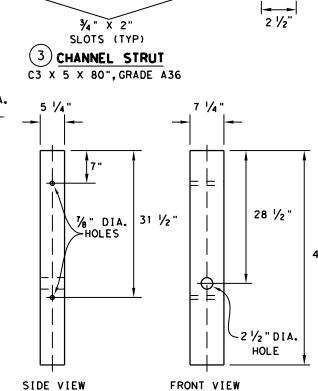
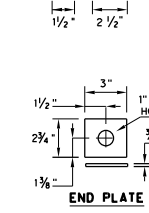
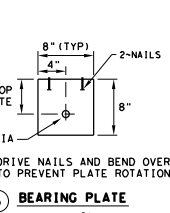
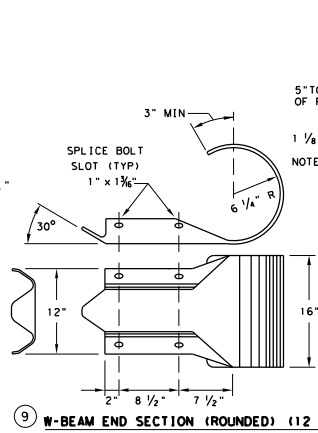
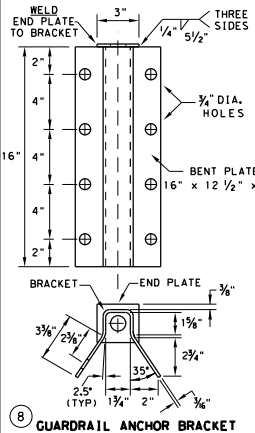
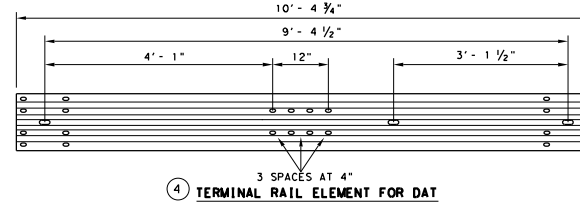

Texas Department of Transportation Design Division Standard

METAL BEAM GUARD FENCE (DOWNSTREAM ANCHOR TERMINAL) TL-3 MASH COMPLIANT GF (31) DAT-19

FILE: gf31dat19.dgn	DW: TxDOT	CK: KM	DR: VP	CR: CGL/AG
© TxDOT: NOVEMBER 2019	CONT SECT	JOB	HIGHWAY	
REVISIONS	641738	001	US 96, etc.	
	DIST	COUNTY	SHEET NO.	
	LFK	San Augustine	30	

DISCUSS: THIS STANDARD IS COVERED BY THE "TEXAS ENGINEERING PRACTICE ACT". NO WARRANTY OF ANY KIND IS MADE BY TxDOT FOR ANY PURPOSE WHATSOEVER. TxDOT ASSUMES NO RESPONSIBILITY FOR THE CONVERSION OF THIS STANDARD TO OTHER FORMATS OR FOR INCORRECT RESULTS OR DAMAGES RESULTING FROM ITS USE.
 DATE: 11/17/2022
 FILE: TL-3EKOAMgmt Contracts\0-RMC - Routine Maintenance Contracts\123 Plans\6417-38-001 San Augustine MBGF\DOWNSTREAM GUARD FENCE STD.GF (31) DAT-19.dgn

DISCUSS: THIS STANDARD IS COVERED BY THE "TEXAS ENGINEERING PRACTICE ACT". NO WARRANTY OF ANY KIND IS MADE BY TxDOT FOR ANY PURPOSE WHATSOEVER. TxDOT ASSUMES NO RESPONSIBILITY FOR THE CONVERSION OF THIS STANDARD TO OTHER FORMATS OR FOR INCORRECT RESULTS OR DAMAGES RESULTING FROM ITS USE.
 DATE: 11/17/2022
 FILE: T:\LKFD\MA\mnt Contracts\0-RMC - Routine Maintenance Contracts\17-38-001 San Augustine\MBGF\DDN\STANDARD-GUARD FENCE STD.GF (31)LS-19.dgn

NOTE: TOENAIL WITH ONE 16D GALV. NAIL TO PREVENT BLOCK ROTATION.

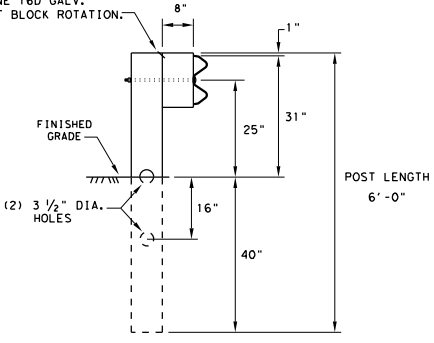

**RECTANGULAR CRT POST
(6' X 8" X 6' LONG)**

(6) CRT REQUIRED
SEE ELEVATION DETAIL FOR LOCATIONS

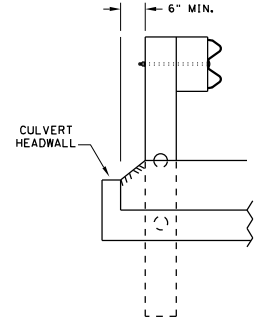

**LATERAL OFFSET BETWEEN THE
GUARDRAIL AND THE CULVERT HEADWALL**

GENERAL NOTES

1. THE TYPE OF LINE POST (ROUND WOOD POST, RECTANGULAR WOOD POST, OR STEEL POST) WILL BE AS SHOWN IN THE PLANS. THE EXACT POSITION OF THE TRANSITIONS SHALL BE AS SHOWN IN THE PLANS OR AS DIRECTED BY THE ENGINEER. STEEL POSTS TO BE GALVANIZED IN ACCORDANCE WITH ITEM 445, "GALVANIZING."
2. RAIL ELEMENT SHALL MEET ALL REQUIREMENTS OF ITEM 540, "METAL BEAM GUARD FENCE" EXCEPT AS MODIFIED ON THE PLANS. THE CONTRACTOR MAY FURNISH RAIL ELEMENTS OF 12' - 6" OR 25' - 0" NOMINAL LENGTHS.
3. RAIL POST HOLES ARE OFFSET 3' - 1 1/2" FROM STANDARD GUARDRAIL TO ACCOMMODATE THE MIDSPAN SPLICING.
4. BUTTON HEAD "POST BOLTS & NUTS" SHALL MEET THE REQUIREMENTS OF (ASTM A307), AND SHALL BE OF SUFFICIENT LENGTH TO EXTEND THROUGH THE FULL THICKNESS OF THE NUT AND 5/8" WASHER (FNC16g) AND NO MORE THAN 1" BEYOND IT.
5. FITTINGS (BOLTS, NUTS, AND WASHERS) SHALL BE GALVANIZED IN ACCORDANCE WITH ITEM 445, "GALVANIZING". FITTINGS SHALL BE SUBSIDIARY TO THE BID ITEM.
6. WHERE SOLID ROCK IS ENCOUNTERED, CONTACT THE DESIGN DIVISION FOR ADDITIONAL GUIDANCE. (512) 416-2678
7. POSTS SHALL NOT BE SET IN CONCRETE, OF ANY DEPTH.
8. REFER TO GF (31) STANDARD SHEET FOR ADDITIONAL DETAILS.
9. FLAME CUTTING OF HOLES IN GUARDRAIL SHALL NOT BE PERMITTED. IF YOU ENCOUNTER MIS-ALIGNED BOLT HOLES IN GUARDRAIL CONTACT THE DESIGN DIVISION FOR ADDITIONAL INFORMATION & OPTIONS.

NOTE: SEE GF (31) STANDARD FOR STANDARD LINE POSTS.

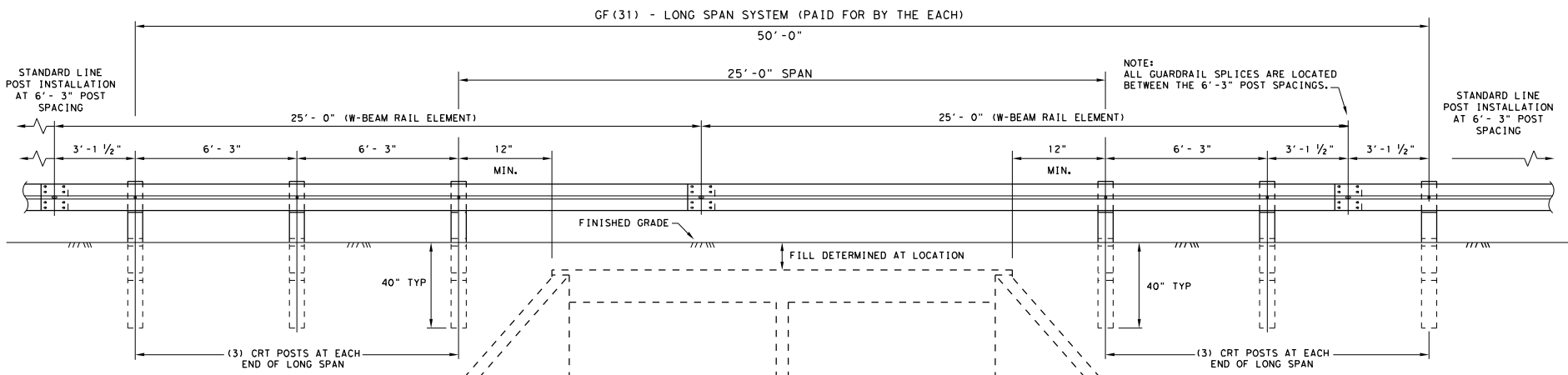

**ELEVATION DETAIL
LONG SPAN GUARDRAIL**

				Design Division Standard	
METAL BEAM GUARD FENCE LONG SPAN TL-3 MASH COMPLIANT GF (31)LS-19					
FILE: gf31ls19.dgn	DN: TxDOT	CR: KM	DR: VP	CR: CGL/AG	
© TxDOT: NOVEMBER 2019	CONT: 6417	SECT: 38	JOB: 001	HIGHWAY: US 96, etc.	
	DIST: LFK	COUNTY: San Augustine	SHEET NO.: 31		

DISCUSS W/ER
 THIS STANDARD IS COVERED BY THE "TEXAS ENGINEERING PRACTICE ACT" - NO WARRANTY OF ANY KIND IS MADE BY TxDOT FOR ANY PURPOSE WHATSOEVER
 TxDOT ASSUMES NO RESPONSIBILITY FOR THE CONVERSION OF THIS STANDARD TO OTHER FORMATS OR FOR INCORRECT RESULTS OR DAMAGES RESULTING FROM ITS USE.
 DATE: 11/17/2022
 FILE: T:\L\FKDM\Maint Contracts\0.RMC - Routine Maintenance Contracts\1723 Plans\6417-38-001 San Augustine MBGF\DDN\STANDARD-GUARD FENCE STD\GF (31)T101-19.dgn

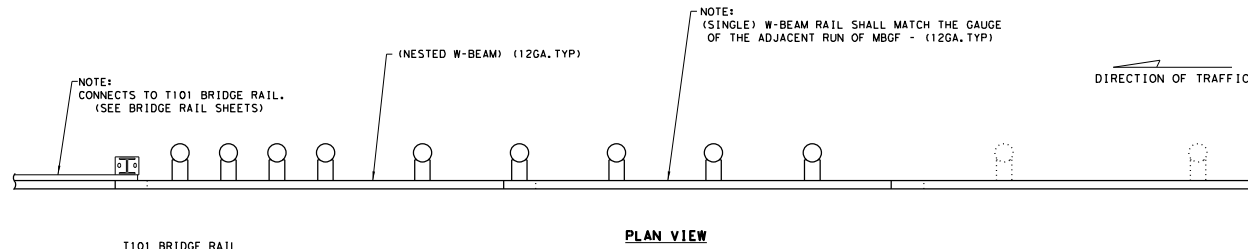

- GENERAL NOTES**
1. THE TYPE OF POST (ROUND WOOD POST, RECTANGULAR WOOD POST, OR STEEL POST) WILL BE AS SHOWN IN THE PLANS. THE EXACT POSITION OF MBGF SHALL BE SHOWN IN THE PLANS OR AS DIRECTED BY THE ENGINEER. STEEL POSTS TO BE GALVANIZED IN ACCORDANCE WITH ITEM 445, "GALVANIZING."
 2. RAIL ELEMENT SHALL MEET THE REQUIREMENTS OF ITEM 540, "METAL BEAM GUARD FENCE" EXCEPT AS MODIFIED IN THE PLANS. THE CONTRACTOR MAY FURNISH RAIL ELEMENTS OF 25'-0", OR 12'-6" (NOM.) LENGTHS. RAIL ELEMENTS MAY HAVE SLOTTED HOLES AT 3'-1 1/2" C-C OR 6'-3" C-C. A SPECIAL LENGTH OF RAIL MAY BE MANUFACTURED TO ACCOMMODATE THE TRANSITION SECTIONS OF GUARDRAIL.
 3. BUTTON HEAD "POST" BOLTS (ASTM A307 GR. A) SHALL BE OF SUFFICIENT LENGTH TO EXTEND THROUGH THE FULL THICKNESS OF THE NUT (ASTM A563) AND 3/8" ROUND WASHER (ASTM F436) AND NOT MORE THAN 1" BEYOND IT. BUTTON HEAD "SPLICE" BOLTS (ASTM A307) ARE 3/4" X 1-1/4" WITH 3/8" NUTS (ASTM A563).
 4. FITTINGS (BOLTS, NUTS, AND WASHERS) SHALL BE GALVANIZED IN ACCORDANCE WITH ITEM 445, "GALVANIZING." FITTINGS SHALL BE SUBSIDIARY TO THE BID ITEM REQUIRING CONSTRUCTION OF THE TRANSITION.
 5. CROWN SHALL BE WIDENED TO ACCOMMODATE THE METAL BEAM GUARD FENCE.
 6. WHERE SOLID ROCK IS ENCOUNTERED. CONTACT THE DESIGN DIVISION FOR ADDITIONAL GUIDANCE. (512) 416-2678
 7. POSTS SHALL NOT BE SET IN CONCRETE.
 8. UNLESS OTHERWISE SHOWN IN THE PLANS, A COMPOSITE MATERIAL BLOCK THAT MEETS THE REQUIREMENTS OF DMS-7210, "COMPOSITE MATERIAL POSTS AND BLOCKS FOR METAL BEAM GUARD FENCE" MAY BE SUBSTITUTED FOR BLOCKS OF SIMILAR DIMENSIONS. THE CONSTRUCTION DIVISION, TxDOT MAINTAINS A MATERIAL PRODUCER LIST (MPL) FOR PRODUCERS OF MATERIALS CONFORMING TO DMS-7210. ONLY PRODUCERS ON THE MPL MAY FURNISH COMPOSITE MATERIAL BLOCKS.
 9. REFER TO STANDARD GF (31) AND APPLICABLE BRIDGE RAILING STANDARD FOR ADDITIONAL DETAILS.

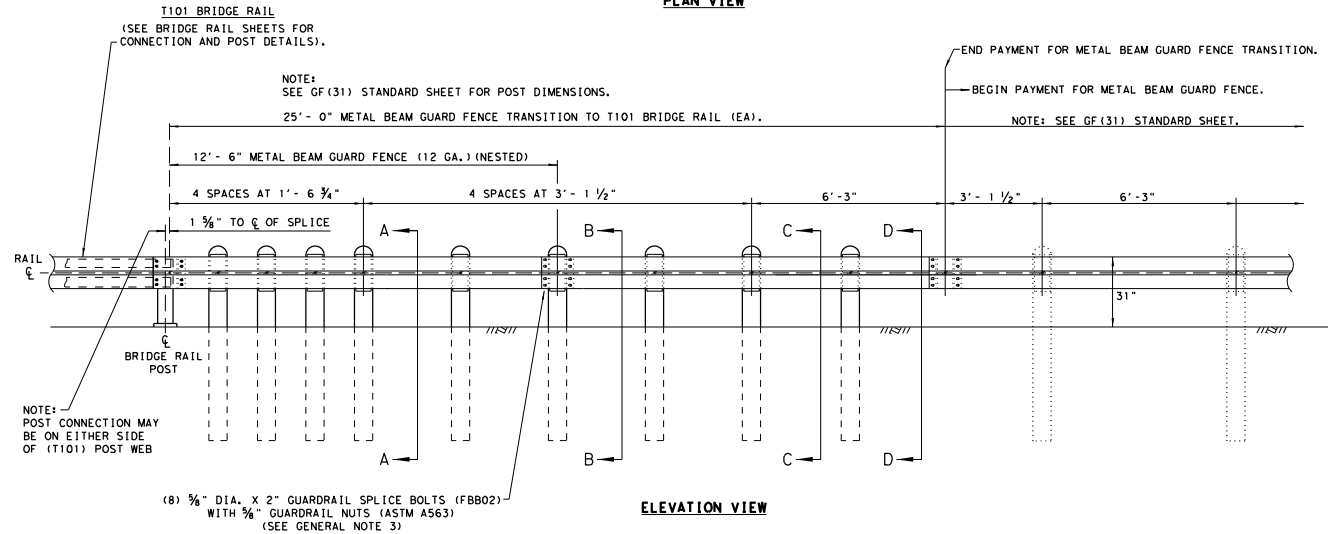

* "WOOD" INDICATES DIMENSIONS FOR BOTH ROUND AND RECTANGULAR WOOD POST SYSTEMS.

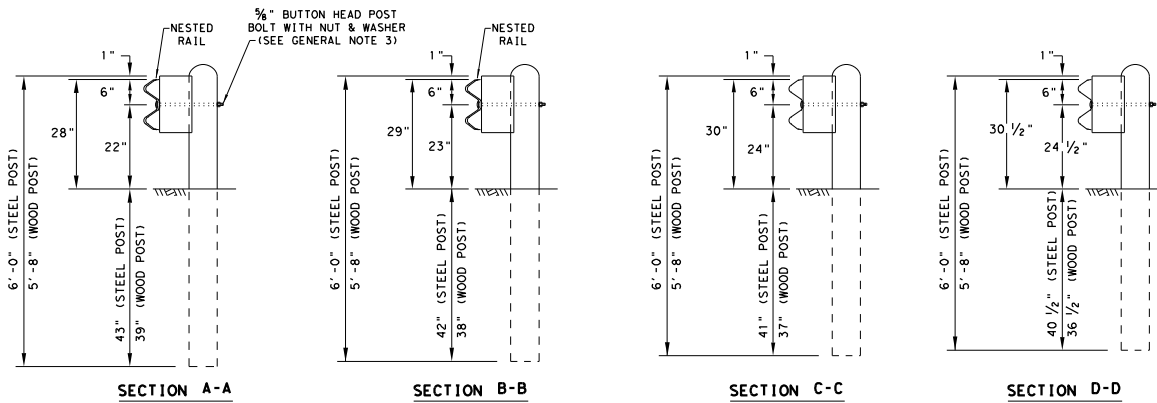

		Design Division Standard	
METAL BEAM GUARD FENCE TRANSITION (T101) GF (31) T101-19			
FILE: gf31t10119	DN: TxDOT	CK: KM	DR: VP
© TxDOT: NOVEMBER 2019	CONT SECT	JOB	HIGHWAY
REVISIONS	6417	38	001
DIST	COUNTY		US 96, et.c.
LFK	San Augustine		SHEET NO. 32

DISCLAIMER: THE USE OF THIS STANDARD IS GOVERNED BY THE "TEXAS ENGINEERING PRACTICE ACT". NO WARRANTY OF ANY KIND IS MADE BY TXDOT FOR ANY PURPOSE WHATSOEVER. TXDOT ASSUMES NO RESPONSIBILITY FOR THE CONVERSION OF THIS STANDARD TO OTHER FORMATS OR FOR INCORRECT RESULTS OR DAMAGES RESULTING FROM ITS USE.

DATE: 11/17/2022 2:18:04 PM
 FILE: T:\LFDK\WgInt\Contracts\0-RMC - Routine Maintenance Contracts\123 Plots\6417-38-001 San Augustine MBGF\DDN\STANDARD-GUARD FENCE STD\GF (31) TR TL2-19.dgn

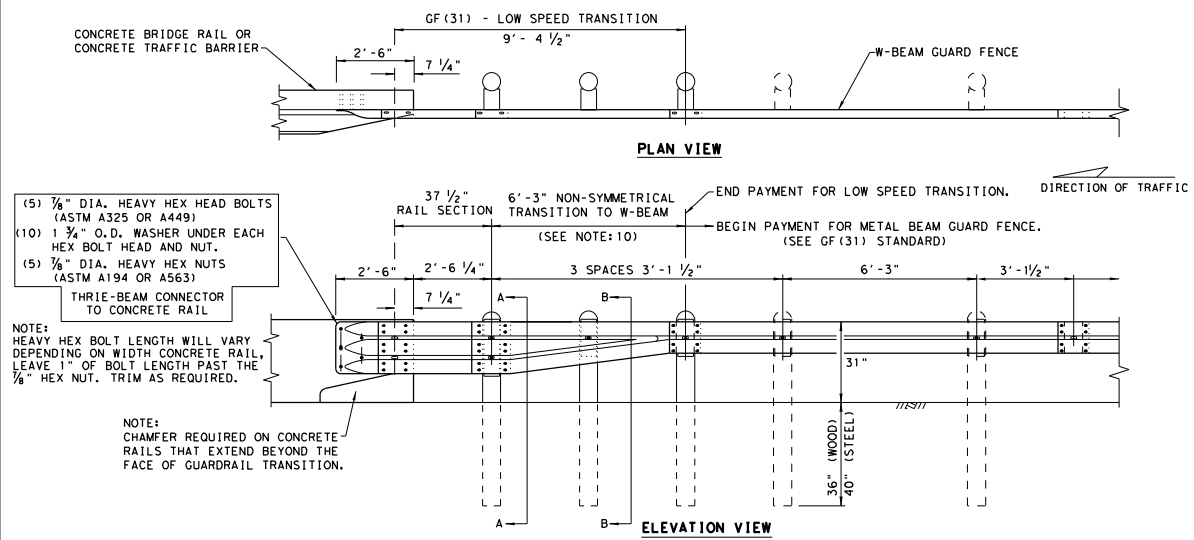

- (5) 7/8" DIA. HEAVY HEX HEAD BOLTS (ASTM A325 OR A449)
 - (10) 1 3/4" O.D. WASHER UNDER EACH HEX BOLT HEAD AND NUT.
 - (5) 7/8" DIA. HEAVY HEX NUTS (ASTM A194 OR A563)
- THRIE-BEAM CONNECTOR TO CONCRETE RAIL

NOTE: HEAVY HEX BOLT LENGTH WILL VARY DEPENDING ON WIDTH CONCRETE RAIL. LEAVE 1" OF BOLT LENGTH PAST THE 7/8" HEX NUT. TRIM AS REQUIRED.

NOTE: CHAMFER REQUIRED ON CONCRETE RAILS THAT EXTEND BEYOND THE FACE OF GUARDRAIL TRANSITION.

GENERAL NOTES

1. THE TYPE OF POST (ROUND WOOD POST, RECTANGULAR WOOD POST, OR STEEL POST) WILL BE AS SHOWN IN THE PLANS. THE EXACT POSITION OF TRANSITIONS SHALL BE AS SHOWN IN THE PLANS OR AS DIRECTED BY THE ENGINEER. REFER TO GF (31) STANDARD SHEET.
2. RAIL ELEMENT SHALL MEET THE REQUIREMENTS OF ITEM 540, "METAL BEAM GUARD FENCE" EXCEPT AS MODIFIED IN THE PLANS.
3. FITTINGS (BOLTS, NUTS, AND WASHERS) SHALL BE GALVANIZED IN ACCORDANCE WITH ITEM 445, "GALVANIZING." FITTINGS SHALL BE SUBSIDIARY TO THE BID ITEM REQUIRING CONSTRUCTION OF THE TRANSITION.
4. BUTTON HEAD "POST BOLTS & NUTS" SHALL MEET THE REQUIREMENTS OF (ASTM A307), AND SHALL BE OF SUFFICIENT LENGTH TO EXTEND THROUGH THE FULL THICKNESS OF THE NUT AND 3/8" WASHER (FWC16G) AND NOT MORE THAN 1" BEYOND IT. TRIM BOLT LENGTH TO MEET REQUIRED LENGTH.
5. POSTS SHALL NOT BE SET IN CONCRETE, OF ANY DEPTH.
6. CROWN SHALL BE WIDENED TO ACCOMMODATE TRANSITIONS.
7. WHERE SOLID ROCK IS ENCOUNTERED, CONTACT THE DESIGN DIVISION FOR ADDITIONAL GUIDANCE. (512) 416-2678
8. UNLESS OTHERWISE SHOWN IN THE PLANS, A COMPOSITE MATERIAL BLOCK THAT MEETS THE REQUIREMENTS OF DMS-7210, "COMPOSITE MATERIAL POSTS AND BLOCKS FOR METAL BEAM GUARD FENCE" MAY BE SUBSTITUTED FOR BLOCKS OF SIMILAR DIMENSIONS. THE CONSTRUCTION DIVISION, TXDOT, MAINTAINS A MATERIAL PRODUCER LIST (MPL) FOR PRODUCERS OF MATERIALS CONFORMING TO DMS-7210. ONLY PRODUCERS ON THE MPL CAN FURNISH COMPOSITE MATERIAL BLOCKS.
9. REFER TO GF (31) STANDARD SHEET & BRIDGE RAILING DETAILS FOR ADDITIONAL DETAILS.
10. FOR ROUND WOOD POSTS SYSTEMS, ALL ROUND WOOD POSTS SHALL BE 7 1/2" DIA. MINIMUM THROUGHOUT THE TRANSITION.

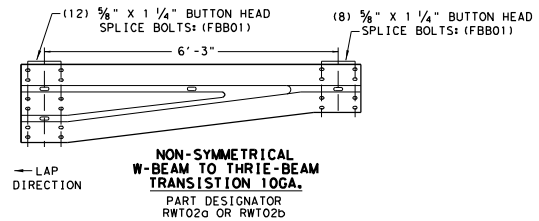
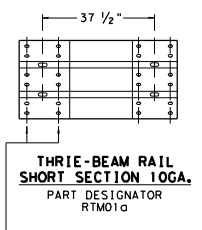
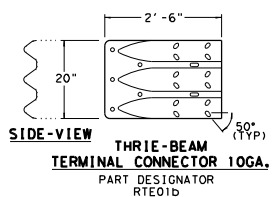

- (2) 5/8" BUTTON HEAD POST BOLTS & NUTS: (FBB04)
- (1) 3/8" FLAT WASHER: (FWC14g) UNDER EACH NUT

BRIDGE APPROACH - UPSTREAM: THE SHORT RAIL LAPS OVER THE TERMINAL CONNECTOR. PLATE WASHERS ARE INSTALLED UNDER THE SPLICE NUTS AGAINST INSIDE OF CONNECTOR.
 BRIDGE EXIT - DOWNSTREAM: THE TERMINAL CONNECTOR LAPS OVER THE NESTED RAIL. PLATE WASHERS ARE INSTALLED UNDER THE BOLT HEAD AGAINST OUTSIDE OF CONNECTOR.

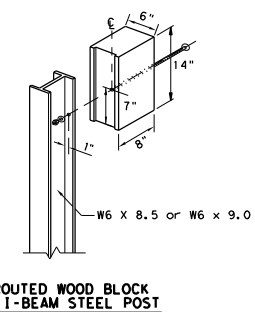
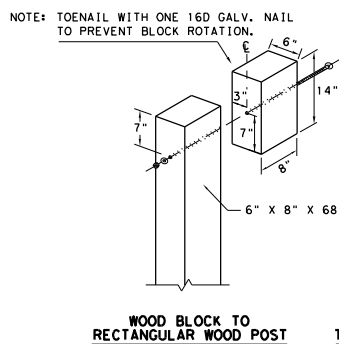
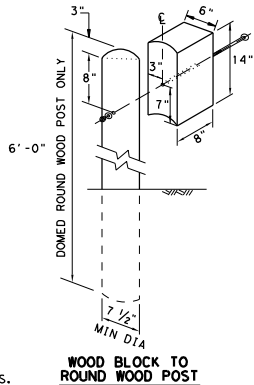
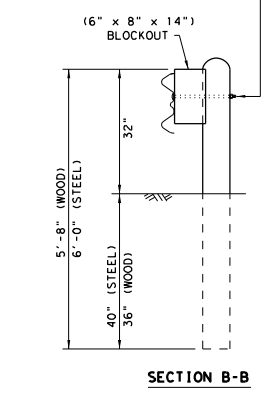
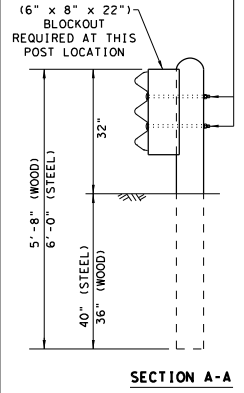

NOTE: * "WOOD" INDICATES DIMENSIONS FOR BOTH ROUND AND RECTANGULAR WOOD POST SYSTEMS.

LOW-SPEED TRANSITION

		Design Division Standard	
METAL BEAM GUARD FENCE THRIE-BEAM TRANSITION TL-2 MASH COMPLIANT GF (31) TR TL2-19			
FILE: gf31trtl219.dgn	DN: TXDOT	CK: KM	DR: VP
© TXDOT: NOVEMBER 2019	CONT SECT	JOB	HIGHWAY
REVISIONS	6417	38	001
DIST	COUNTY		US 96, et.c.
LFK	San Augustine		SHEET NO. 33

DISCUSS W/CR: THIS STANDARD IS COVERED BY THE "TEXAS ENGINEERING PRACTICE ACT". NO WARRANTY OF ANY KIND IS MADE BY TxDOT FOR ANY PURPOSE WHATSOEVER. TxDOT ASSUMES NO RESPONSIBILITY FOR THE CONVERSION OF THIS STANDARD TO OTHER FORMATS OR FOR INCORRECT RESULTS OR DAMAGES RESULTING FROM ITS USE.
 DATE: 11/17/2022
 FILE: T:\LKFDMA\mnt\contracts\0-RMC - Routine Maintenance\contracts\1723 Plots\6417-38-001 Son Augustine MBGF\DOWNSTANDARD-GUARD FENCE STD.GF (3)1TR TL3-20.dgn

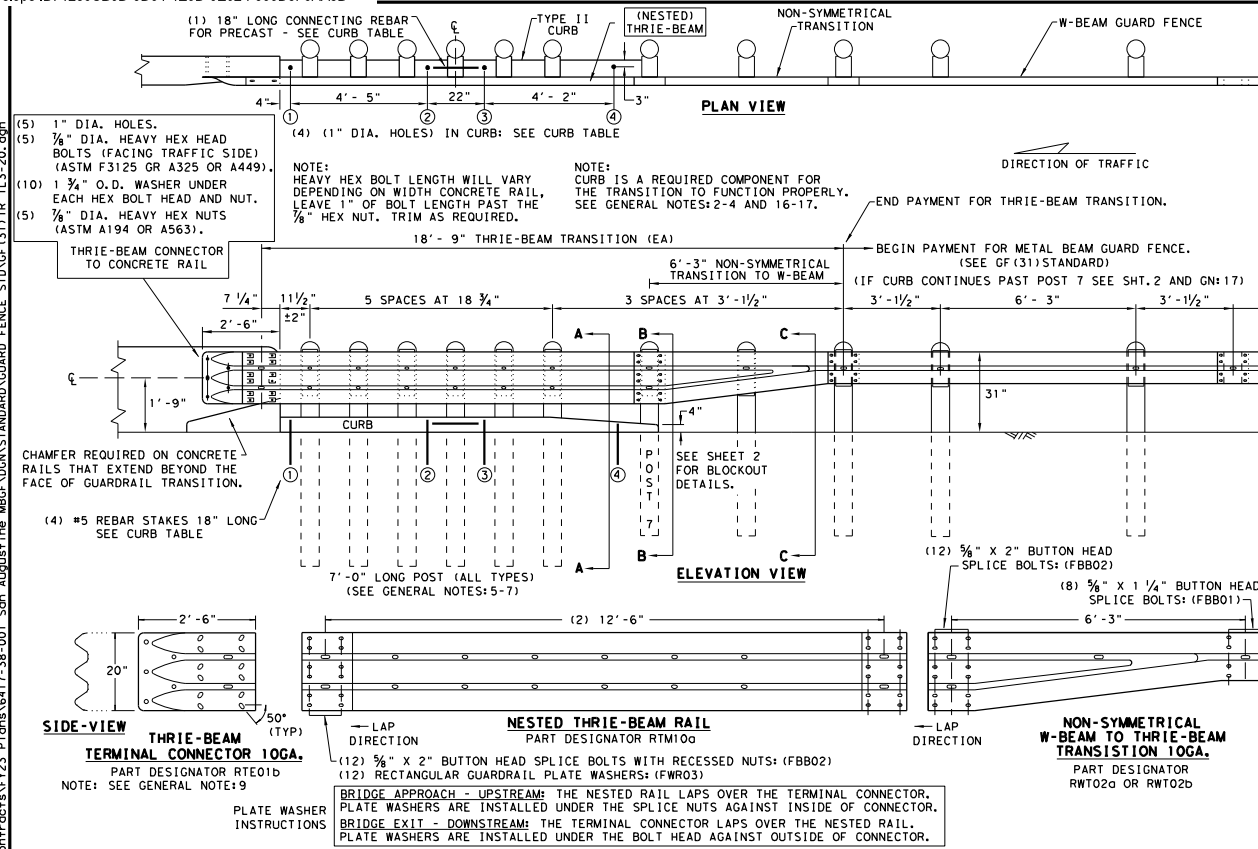

- ### GENERAL NOTES
- CONTACT THE DESIGN DIVISION FOR DRAINAGE CUT OUT OPTIONS NEEDED WITHIN THE CURB SECTION OF THE THRIE-BEAM TRANSITION. (512) 416-2678
 - CONCRETE CURB MAY BE CAST-IN-PLACE OR PRECAST AS SHOWN ON THIS SHEET. WHEN USED IN CONJUNCTION WITH THE THRIE-BEAM TRANSITIONS, CURB SHALL BE TYPE II (5'-3/4" HEIGHT); SEE CURRENT CCG STANDARD SHEET FOR FURTHER DETAILS. IF OTHER CURB HEIGHTS ARE SHOWN IN THE PLANS IN CONJUNCTION WITH THE TRANSITION, THE CURB HEIGHT MAY BE FROM 4" TO 8" WITH A RELATIVELY VERTICAL FACE. CONCRETE CURB SHALL BE CONTINUOUS TO THE SEVENTH POST UNLESS OTHERWISE SHOWN IN THE PLANS. SEE GENERAL NOTE 17 FOR CIRCUMSTANCES WHERE CURB CONTIGUES PAST POST 7.
 - CONCRETE CURB TYPE II SUBSIDIARY TO "METAL BEAM GUARD FENCE TRANSITION". IF NO ADDITIONAL CURB IS INDICATED BEYOND THE TRANSITION, THEN ANY CURB HEIGHT GREATER THAN 4" WILL BE TAPERED DOWN BEGINNING AT THE LAST 7 FT. POST TO A MAXIMUM HEIGHT OF 4" AT POST 7. IF SHOWN ELSEWHERE IN THE PLANS, ADDITIONAL CURB UNDERNEATH GUARDRAIL WILL BE PAID FOR BY THE LINEAR FOOT.
 - UNLESS OTHERWISE SHOWN IN THE PLANS, TRANSITIONS SHALL BE PLACED WITH THE BLOCKOUT FACE IN FRONT OF OR DIRECTLY ABOVE THE CURB FACE. SEE SECTION A-A.
 - FOR ROUND WOOD POST SYSTEMS, ALL ROUND WOOD POSTS SHALL BE 7 1/2" DIA. MINIMUM THROUGHOUT THE THRIE-BEAM TRANSITION.
 - THE TYPE OF POST (ROUND WOOD POST, RECTANGULAR WOOD POST OR STEEL POST) WILL BE AS SHOWN IN THE PLANS. REFER TO GF (31) STANDARD SHEET.
 - THE POST LENGTH SHALL BE MARKED ON ALL 7'-0" LONG POSTS BY THE MANUFACTURER. THE MARK SHALL BE LOCATED WITHIN THE TOP 1 FT. REGION OF THE POST, AT LEAST 3/4" IN HEIGHT, AND VISIBLE AFTER INSTALLATION. WOODEN POSTS SHALL BE MARKED WITH A BRAND, AND STEEL POSTS WITH A STENCIL BEFORE GALVANIZING.
 - POSTS SHALL NOT BE SET IN CONCRETE, OF ANY DEPTH.
 - RAIL ELEMENTS SHALL MEET THE REQUIREMENTS OF ITEM 540, "METAL BEAM GUARD FENCE" EXCEPT AS MODIFIED ON THE PLANS. THE THRIE-BEAM TERMINAL CONNECTOR AND THE THRIE-BEAM TRANSITION TO W-BEAM SHALL BE OF THE SAME MATERIAL, BUT SHALL NOT BE LESS THAN 10 GAUGE. CONTRACTOR SHALL VERIFY THAT THE LOCATIONS OF BOLT HOLES MATCH THOSE IN THE THRIE-BEAM TERMINAL CONNECTOR PRIOR TO ORDERING MATERIALS.
 - BUTTON HEAD "POST BOLTS & NUTS" SHALL MEET THE REQUIREMENTS OF (ASTM A307), AND SHALL BE OF SUFFICIENT LENGTH TO EXTEND THROUGH THE FULL THICKNESS OF THE NUT AND 3/4" WASHER (FWC16G) AND NOT MORE THAN 1" BEYOND IT. TRIM REMAINING BOLT LENGTH TO MEET REQUIRED LENGTH.
 - FITTINGS (BOLTS, NUTS, AND WASHERS) SHALL BE GALVANIZED IN ACCORDANCE WITH ITEM 445, "GALVANIZING". FITTINGS SHALL BE SUBSIDIARY TO THE BID ITEM.
 - CROWN SHALL BE WIDENED TO ACCOMMODATE TRANSITIONS.
 - WHERE SOLID ROCK IS ENCOUNTERED, CONTACT THE DESIGN DIVISION FOR ADDITIONAL GUIDANCE. (512) 416-2678
 - UNLESS OTHERWISE SHOWN IN THE PLANS, A COMPOSITE MATERIAL BLOCK THAT MEETS THE REQUIREMENTS OF DMS-7210, "COMPOSITE MATERIAL POSTS AND BLOCKS FOR METAL BEAM GUARD FENCE" MAY BE SUBSTITUTED FOR BLOCKS OF SIMILAR DIMENSIONS. TxDOT'S MATERIALS AND TESTS DIVISION MAINTAINS A MATERIAL PRODUCER LIST (MPL) FOR PRODUCERS OF MATERIALS CONFORMING TO DMS-7210. ONLY PRODUCERS ON THE MPL CAN FURNISH COMPOSITE MATERIAL BLOCKS.
 - REFER TO GF (31) STANDARD SHEET & BRIDGE RAILING DETAILS FOR ADDITIONAL DETAILS.
 - THE INSTALLATION OF THE TYPE II CURB IS CRITICAL FOR THE PERFORMANCE OF THE THRIE-BEAM TRANSITION SYSTEM. THE CURB PREVENTS (VEHICLE WHEEL SNAGGING) AT THE CONCRETE RAIL AND IS REQUIRED TO MEET MASH CRASH TEST CRITERIA.
 - IF CURB EXTENDS BEYOND POST 7, 25' OF NESTED W-BEAM GUARDRAIL SHALL BE INSTALLED BEYOND THE PAY LIMITS OF THRIE-BEAM TRANSITION SECTION. (SEE SHT. 2). PAYMENT FOR THIS 25' SECTION WILL BE BY LINEAR FOOT, PAY ITEM "0540 6XXX MTL W-BEAM GD FEN (NESTED) (TIM POST)" OR "540 6XXX MTL W-BEAM GD FEN (NESTED) (STEEL POST)" AS APPLICABLE FOR POST TYPE. SEE SHT. 2 FOR ADDITIONAL INFORMATION.

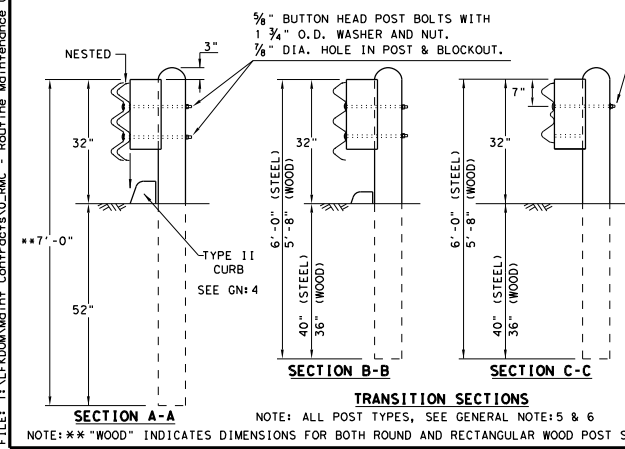

THRIE-BEAM TERMINAL - CURB TABLE	
PRECAST CURB FULL LENGTH EQUALS 12'-2"	
THE PRECAST CURB MAY BE FORMED INTO TWO SECTIONS.	
CURB (1)	LENGTH 5'-8"
CURB (2)	LENGTH 6'-6"
TAPER CURB (2) TO A HEIGHT OF 4" AT POST 7	
CONNECTING PRECAST CURB SECTIONS (1) & (2):	
FORM OR CORE 1" DIA. HOLE 9" LONG INTO EACH CURB END.	
USE (1)	#5 GR. 60 REBAR 18" LONG TO CONNECT BOTH CURBS.
SECURING PRECAST OR CAST-IN-PLACE TO FINISHED GRADE "s":	
FORM OR CORE (4) 1" DIA. HOLES, SEE PLAN AND ELEVATION VIEWS FOR HOLE LOCATIONS. DRIVE (4) #5 GR. 60 REBAR STAKES 18" LONG INTO THE GROUND AND 1/2" BELOW TOP OF CURB.	
FILL HOLES WITH APPROVED GROUT MIXTURE.	

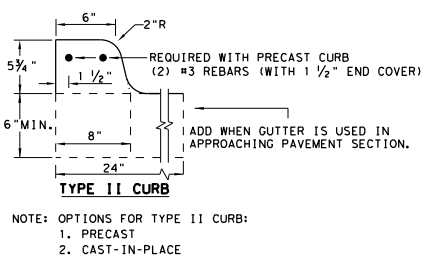

* NOTES: NOT NEEDED FOR CAST-IN-PLACE. SEE TYPE II CURB DETAIL FOR REBAR AND COVER REQUIREMENTS. PERCUSSION DRILLING IS NOT PERMITTED WITH TYPE II CURB, BRIDGE RAIL OR CONCRETE TRAFFIC RAIL.

HIGH-SPEED TRANSITION
SHEET 1 OF 2

Design Division Standard

**METAL BEAM GUARD FENCE
THRIE-BEAM TRANSITION
TL-3 MASH COMPLIANT**

GF (31) TR TL3-20

FILE: gf31tr+1320.dgn	DN: TxDOT	CR: KM	DR: VP	CR: CGL/AG
© TxDOT: NOVEMBER 2020	CONT: 641738	SECT: 001	JOB: US 96, etc.	HIGHWAY
REVISIONS	DIST: LFK	COUNTY: Son Augustine	SHEET NO. 34	

DISCLAIMER: THIS STANDARD IS GOVERNED BY THE "TEXAS ENGINEERING PRACTICE ACT". NO WARRANTY OF ANY KIND IS MADE BY TxDOT FOR ANY PURPOSE WHATSOEVER. TxDOT ASSUMES NO RESPONSIBILITY FOR THE CONVERSION OF THIS STANDARD TO OTHER FORMATS OR FOR INCORRECT RESULTS OR DAMAGES RESULTING FROM ITS USE.
 DATE: 11/17/2022
 FILE: T:\LKDKM\Main\Contract\30.RMC - Routine Maintenance\Contracts\1723 P.lans.1617-38-001 San Augustine MBGF.DGN\STANDARD-GUARD FENCE STD.GF (31).TR TL3-20.dgn

REQUIRED ALTERNATIVE FOR CONTINUOUS CURB EXTENDING PAST POST 7 (SEE SHT. 1 GENERAL NOTE 17)

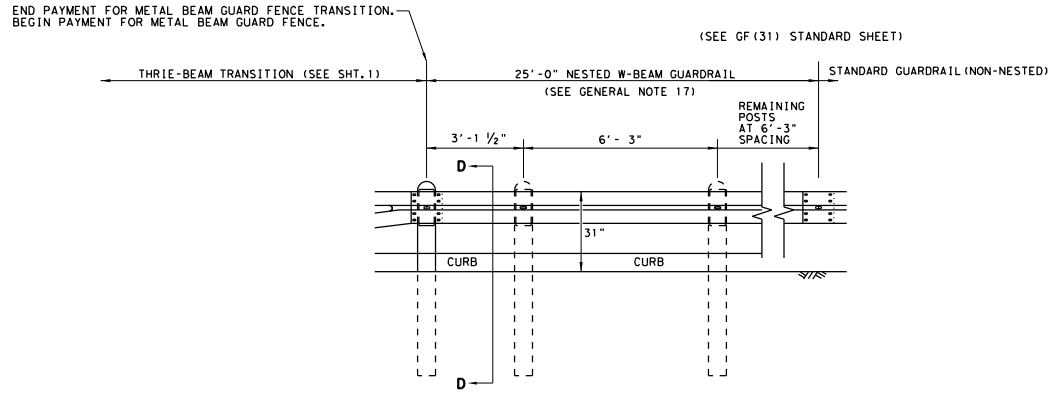

ELEVATION VIEW

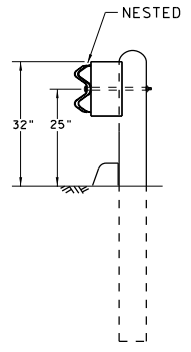

SECTION D-D

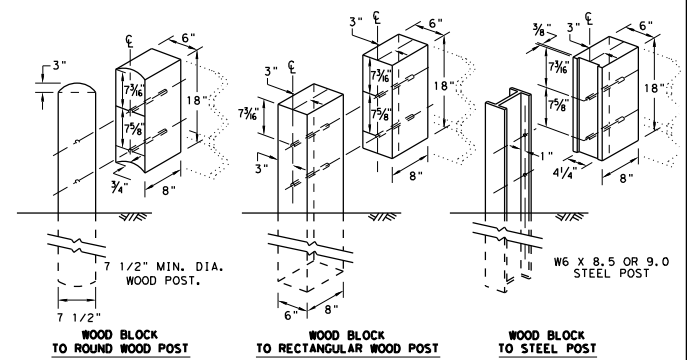

THREE BEAM TRANSITION BLOCKOUT DETAILS

HIGH-SPEED TRANSITION

SHEET 2 OF 2

		Design Division Standard	
METAL BEAM GUARD FENCE THREE-BEAM TRANSITION TL-3 MASH COMPLIANT GF (31) TR TL3-20			
FILE: gf31tr+1320.dgn	DN: TxDOT	CK: KM	DR: KM
© TxDOT: NOVEMBER 2020	CONT SECT	JOB	HIGHWAY
REVISIONS	6417	38	001
	DIST	COUNTY	US 96, et.c.
	LFK	San Augustine	SHEET NO. 35

GENERAL NOTES

1. THE TYPE OF POST (ROUND WOOD POST, RECTANGULAR WOOD POST, OR STEEL POST) WILL BE AS SHOWN IN THE PLANS. THE EXACT POSITION OF MBGF SHALL BE AS SHOWN IN THE PLANS OR AS DIRECTED BY THE ENGINEER. STEEL POSTS TO BE GALVANIZED IN ACCORDANCE WITH ITEM 445, "GALVANIZING."
2. RAIL ELEMENT SHALL MEET THE REQUIREMENTS OF ITEM 540, "METAL BEAM GUARD FENCE" EXCEPT AS MODIFIED IN THE PLANS. THE CONTRACTOR MAY FURNISH RAIL ELEMENTS OF 25'-0", OR 12'-6" (NOM.) LENGTHS. RAIL ELEMENTS MAY HAVE SLOTTED HOLES AT 3'-1 1/2" C-C OR 6'-3" C-C. A SPECIAL LENGTH OF RAIL MAY BE MANUFACTURED TO ACCOMMODATE THE TRANSITION SECTIONS OF GUARDRAIL.
3. BUTTON HEAD "POST" BOLTS (ASTM A307) SHALL BE OF SUFFICIENT LENGTH TO EXTEND THROUGH THE FULL THICKNESS OF THE NUT (ASTM A563) AND 3/4" ROUND WASHER (ASTM F436) AND NOT MORE THAN 1" BEYOND IT. BUTTON HEAD "SPLICE" BOLTS (ASTM A307) ARE 3/4" X 1-1/4" WITH 3/4" NUTS (ASTM A563).
4. FITTINGS (BOLTS, NUTS, AND WASHERS) SHALL BE GALVANIZED IN ACCORDANCE WITH ITEM 445, "GALVANIZING." FITTINGS SHALL BE SUBSIDIARY TO THE BID ITEM REQUIRING CONSTRUCTION OF THE TRANSITION.
5. CROWN SHALL BE WIDENED TO ACCOMMODATE THE METAL BEAM GUARD FENCE.
6. THE LATERAL APPROACH TO THE GUARD FENCE, SHALL HAVE A MAXIMUM SLOPE OF 1V:10H.
7. IF SHOWN ELSEWHERE IN THE PLANS OR AS DIRECTED BY THE ENGINEER, THE GUARD FENCE MAY BE FLARED AT A RATE OF 25:1 OR FLATTER.
8. APPLICATIONS IN SOLID ROCK ARE ONLY ALLOWED WITH STEEL POSTS. SEE GF (31) STANDARD FOR INSTALLATION GUIDANCE.
9. POSTS SHALL NOT BE SET IN CONCRETE.
10. UNLESS OTHERWISE SHOWN IN THE PLANS, A COMPOSITE MATERIAL BLOCK THAT MEETS THE REQUIREMENTS OF DMS-7210, "COMPOSITE MATERIAL POSTS AND BLOCKS FOR METAL BEAM GUARD FENCE" MAY BE SUBSTITUTED FOR BLOCKS OF SIMILAR DIMENSIONS. THE CONSTRUCTION DIVISION, TXDOT MAINTAINS A MATERIAL PRODUCER LIST (MPL) FOR PRODUCERS OF MATERIALS CONFORMING TO DMS-7210. ONLY PRODUCERS ON THE MPL MAY FURNISH COMPOSITE MATERIAL BLOCKS.
11. REFER TO STANDARD GF (31) FOR ADDITIONAL DETAILS.
12. RAIL HEIGHT ADJUSTMENT IS ASSESSED AT TL-3 MASH COMPLIANT FOR STEEL POST HEIGHT TRANSITION TO 28" STEEL POST GUARDRAIL.

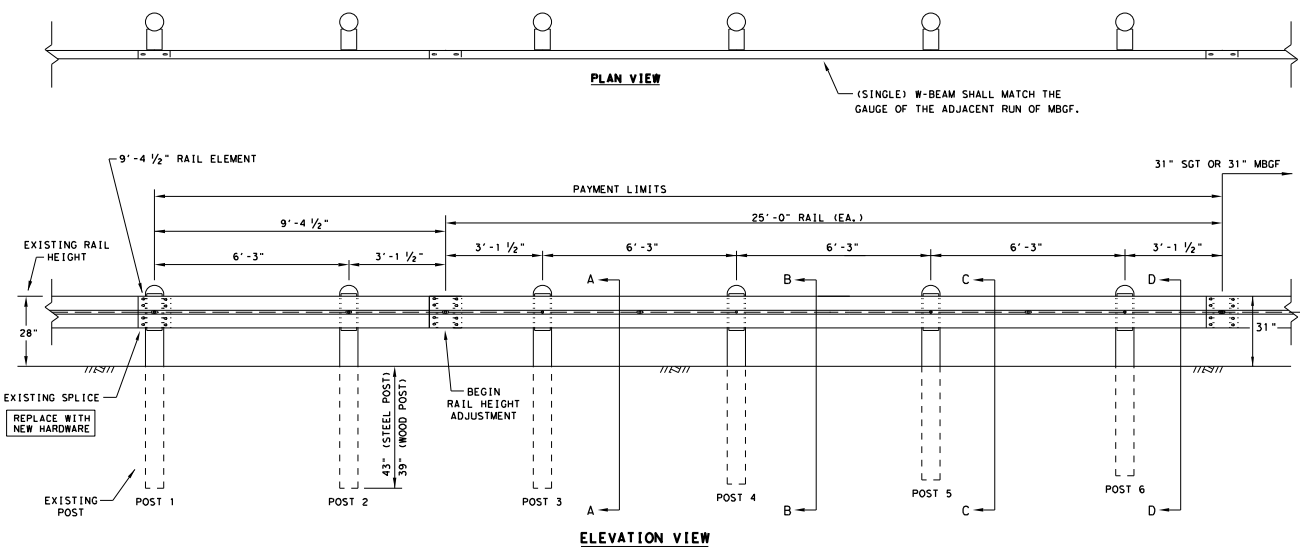

* "WOOD" INDICATES DIMENSIONS FOR BOTH ROUND AND RECTANGULAR WOOD POST SYSTEMS.

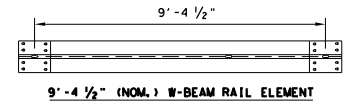
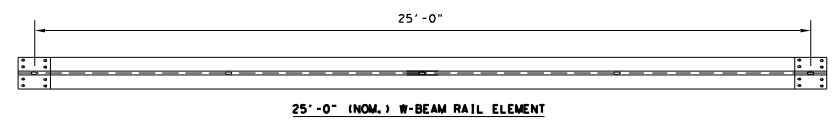
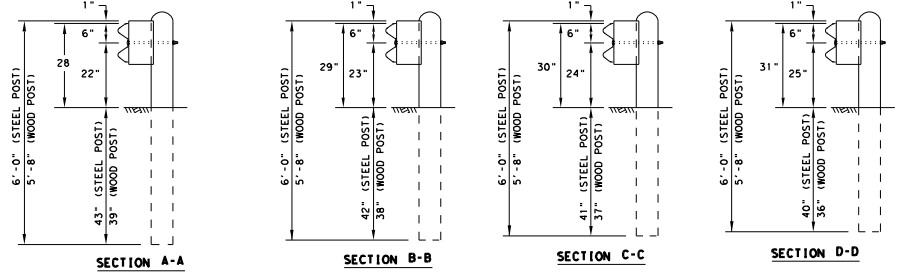

HARDWARE LIST	
QTY	DESCRIPTION
1	9'-4 1/2" W-BEAM RAIL ELEMENT 12GA.
1	25'-0" W-BEAM RAIL ELEMENT 12GA. (TYP)
6	7 1/2" DIA X 6'-0" DOMED ROUND WOOD POSTS (TYP)
6	6" X 8" X 68" RECTANGULAR WOOD POSTS (TYP)
6	W6 X 8.5 OR W6 X 9 X 72" STEEL POSTS (TYP)
6	6" X 8" X 14" WOOD BLOCKS OR COMPOSITE (TYP)
6	3/4" X 18" GUARDRAIL BOLTS WITH NUTS (FBB04)
6	3/4" ROUND WASHERS (ASTM F436) (FWC160)
6	3/4" X 10" GUARDRAIL BOLTS WITH NUTS (FBB03)
24	3/8" X 1-1/4" GUARDRAIL SPLICE BOLTS WITH DOUBLE RECESSED NUTS (ASTM A563) (FBB01)

POST AND BLOCK-OUT TYPES AVAILABLE

FOR WOOD POST

FOR STEEL POST

NOTE: HARDWARE SHALL MEET THE FOLLOWING REQUIREMENTS.

GUARDRAIL POST BOLTS (ASTM A307 GR. A)
 GUARDRAIL ROUND WASHERS (ASTM F436)
 GUARDRAIL DOUBLE RECESSED NUTS (ASTM A563)
 GUARDRAIL SPLICE BOLTS (ASTM A307 GR. A)
 GUARDRAIL SPLICE NUTS (ASTM A563)

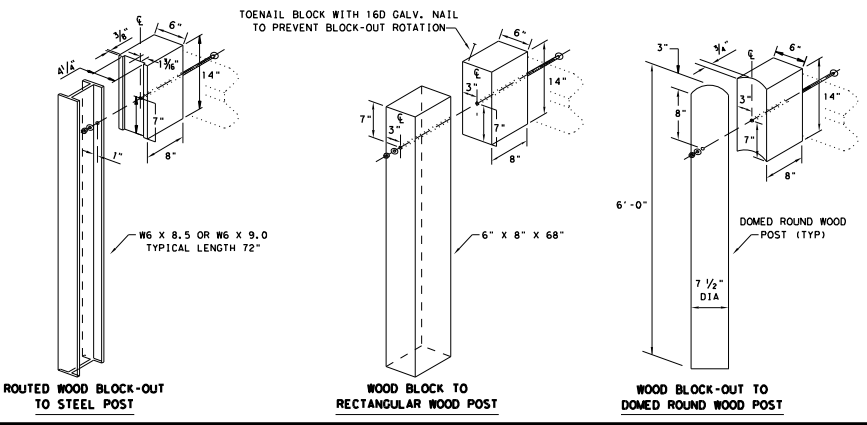

Texas Department of Transportation
 Design Division Standard

**METAL BEAM GUARD FENCE
 RAIL HEIGHT ADJUSTMENT
 (28" TO 31")
 TL-3 MASH COMPLIANT
 RAIL-ADJ(A)-19**

FILE: r01ad019	DN:TXDOT	CK:KM	DR:VP	CK:CGJ/AG
NOVEMBER 2019	CONT SECT	JOB	HIGHWAY	
REVISIONS	641738	001	US 96, etc.	
	DIST	COUNTY	SHEET NO.	
	LFK	San Augustine	36	

DISCLAIMER: THIS STANDARD IS GOVERNED BY THE TEXAS ENGINEERING PRACTICE ACT. NO WARRANTY OF ANY KIND IS MADE BY TxDOT FOR ANY PURPOSE WHATSOEVER. TxDOT ASSUMES NO RESPONSIBILITY FOR THE CONVERSION OF THIS STANDARD TO OTHER FORMATS OR FOR INCORRECT RESULTS OR DAMAGES RESULTING FROM ITS USE.

DATE: 11/17/2022
 FILE: T:\LK\KDM\mnt\ Contracts\0-RMC - Routine Maintenance Contracts\123 Plans\6417-38-001 San Augustine MBGF-UDN\STANDARD-SGT-RAIL-ADJ(B)-19.dgn

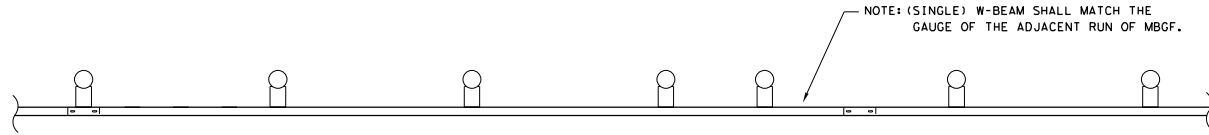

PLAN VIEW

NOTE: (SINGLE) W-BEAM SHALL MATCH THE GAUGE OF THE ADJACENT RUN OF MBGF.

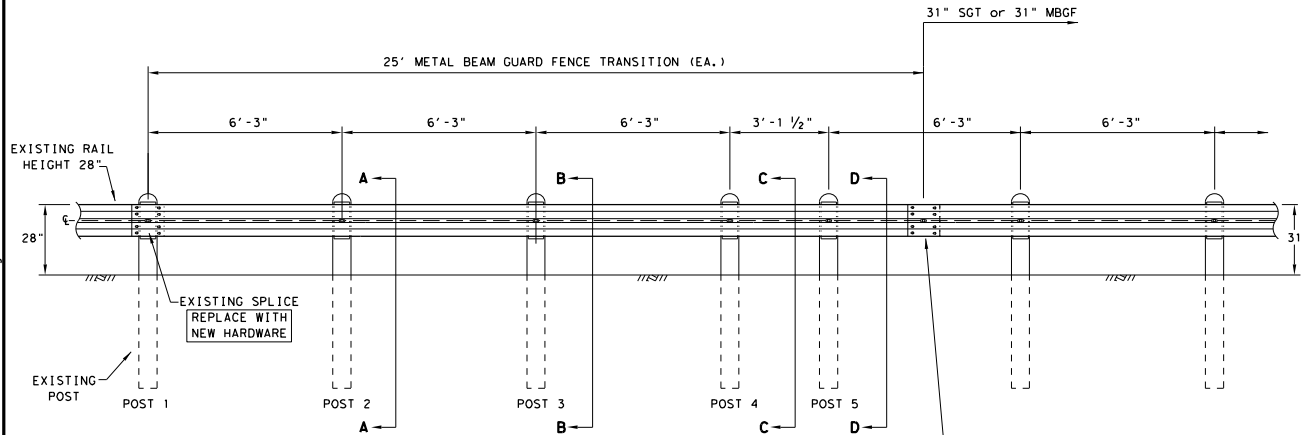

ELEVATION VIEW

* "WOOD" INDICATES DIMENSIONS FOR BOTH ROUND AND RECTANGULAR WOOD POST SYSTEMS.

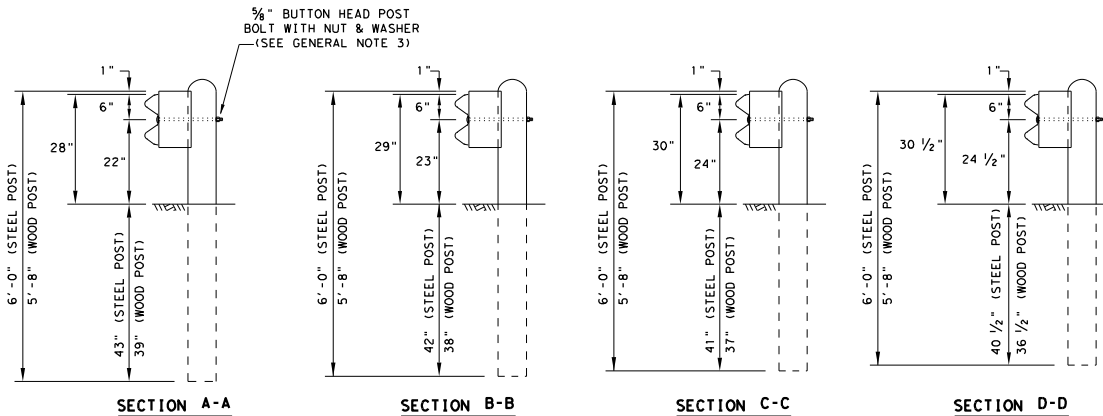

SECTION A-A

SECTION B-B

SECTION C-C

SECTION D-D

NOTE: HARDWARE SHALL MEET THE FOLLOWING REQUIREMENTS.

GUARDRAIL POST BOLTS (ASTM A307 GR. A)
 GUARDRAIL ROUND WASHERS (ASTM F436)
 GUARDRAIL DOUBLE RECESSED NUTS (ASTM A563)
 GUARDRAIL SPLICE BOLTS (ASTM A307 GR. A)
 GUARDRAIL SPLICE NUTS (ASTM A563)

GENERAL NOTES

1. THE TYPE OF POST (ROUND WOOD POST, RECTANGULAR WOOD POST, OR STEEL POST) WILL BE AS SHOWN IN THE PLANS. THE EXACT POSITION OF MBGF SHALL BE AS SHOWN IN THE PLANS OR AS DIRECTED BY THE ENGINEER. STEEL POSTS TO BE GALVANIZED IN ACCORDANCE WITH ITEM 445, "GALVANIZING."
2. RAIL ELEMENT SHALL MEET THE REQUIREMENTS OF ITEM 540, "METAL BEAM GUARD FENCE" EXCEPT AS MODIFIED IN THE PLANS. THE CONTRACTOR MAY FURNISH RAIL ELEMENTS OF 25'-0" OR 12'-6" (NOM.) LENGTHS. RAIL ELEMENTS MAY HAVE SLOTTED HOLES AT 3'-1 1/2" C-C OR 6'-3" C-C. A SPECIAL LENGTH OF RAIL MAY BE MANUFACTURED TO ACCOMMODATE THE TRANSITION SECTIONS OF GUARDRAIL.
3. BUTTON HEAD "POST" BOLTS (ASTM A307) SHALL BE OF SUFFICIENT LENGTH TO EXTEND THROUGH THE FULL THICKNESS OF THE NUT (ASTM A563) AND 3/8" ROUND WASHER (ASTM F436) AND NOT MORE THAN 1" BEYOND IT. BUTTON HEAD "SPLICE" BOLTS (ASTM A307) ARE 3/8" X 1-1/4" WITH 5/8" NUTS (ASTM A563).
4. FITTINGS (BOLTS, NUTS, AND WASHERS) SHALL BE GALVANIZED IN ACCORDANCE WITH ITEM 445, "GALVANIZING." FITTINGS SHALL BE SUBSIDIARY TO THE BID ITEM REQUIRING CONSTRUCTION OF THE TRANSITION.
5. CROWN SHALL BE WIDENED TO ACCOMMODATE THE METAL BEAM GUARD FENCE.
6. THE LATERAL APPROACH TO THE GUARD FENCE, SHALL HAVE A MAXIMUM SLOPE OF 1V:10H.
7. IF SHOWN ELSEWHERE IN THE PLANS OR AS DIRECTED BY THE ENGINEER, THE GUARD FENCE MAY BE FLARED AT A RATE OF 25:1 OR FLATTER.
8. APPLICATIONS IN SOLID ROCK ARE ONLY ALLOWED WITH STEEL POSTS. SEE GF(31) STANDARD FOR INSTALLATION GUIDANCE.
9. POSTS SHALL NOT BE SET IN CONCRETE.
10. UNLESS OTHERWISE SHOWN IN THE PLANS, A COMPOSITE MATERIAL BLOCK THAT MEETS THE REQUIREMENTS OF DMS-7210, "COMPOSITE MATERIAL POSTS AND BLOCKS FOR METAL BEAM GUARD FENCE" MAY BE SUBSTITUTED FOR BLOCKS OF SIMILAR DIMENSIONS. THE CONSTRUCTION DIVISION, TxDOT MAINTAINS A MATERIAL PRODUCER LIST (MPL) FOR PRODUCERS OF MATERIALS CONFORMING TO DMS-7210. ONLY PRODUCERS ON THE MPL MAY FURNISH COMPOSITE MATERIAL BLOCKS.
11. REFER TO STANDARD GF(31) FOR ADDITIONAL DETAILS.
12. RAIL HEIGHT ADJUSTMENT IS ASSESSED AT TL-3 MASH COMPLIANT FOR STEEL POST HEIGHT TRANSITION TO 28" STEEL POST GUARDRAIL.

HARDWARE LIST

QTY	DESCRIPTION
1	25'-0" W-BEAM RAIL ELEMENT 12GA. (TYP)
5	7 1/2" DIA X 6'-0" DOMED ROUND WOOD POSTS (TYP)
5	6" X 8" X 68" RECTANGULAR WOOD POSTS (TYP)
5	W6 X 8.5 OR W6 X 9 X 72" STEEL POSTS (TYP)
5	6" X 8" X 14" WOOD BLOCKS OR COMPOSITE (TYP)
5	5/8" X 18" GUARDRAIL BOLTS AND NUTS (FBB04)
5	3/8" ROUND WASHERS (ASTM F436) (FWC160)
5	3/8" X 10" GUARDRAIL BOLTS AND NUTS (FBB03)
16	3/8" X 1-1/4" GUARDRAIL SPLICE BOLTS WITH DOUBLE RECESSED NUTS (ASTM A563) (FBB01)

POST AND BLOCK-OUT TYPES AVAILABLE

FOR WOOD POST

FOR STEEL POST

		Design Division Standard	
METAL BEAM GUARD FENCE RAIL HEIGHT ADJUSTMENT (28" TO 31") TL-3 MASH COMPLIANT RAIL-ADJ(B)-19			
FILE: r010djb19	DIST: TxDOT	CK: RM	DR: VP
NOVEMBER 2019	CONT: 641738	SECT: 001	JOB: US 96, etc.
REVISIONS	DIST: LFK	COUNTY: San Augustine	SHEET NO: 37

DISCLAIMER: This standard is covered by the "Texas Engineering Practice Act". No warranty of any kind is made by TxDOT for any purpose whatsoever. TxDOT assumes no responsibility for the conversion of this standard to other formats or for incorrect results or damages resulting from its use.

DATE: 11/17/2022
 FILE: T:\LEFKOWITZ\contracts\1232 P10ns\6417-38-001 Son Augustine MBGF\DDN\STANDARD\SGT\10S\31-16.dgn
 Routine Maintenance Contracts\1232 P10ns\6417-38-001 Son Augustine MBGF\DDN\STANDARD\SGT\10S\31-16.dgn

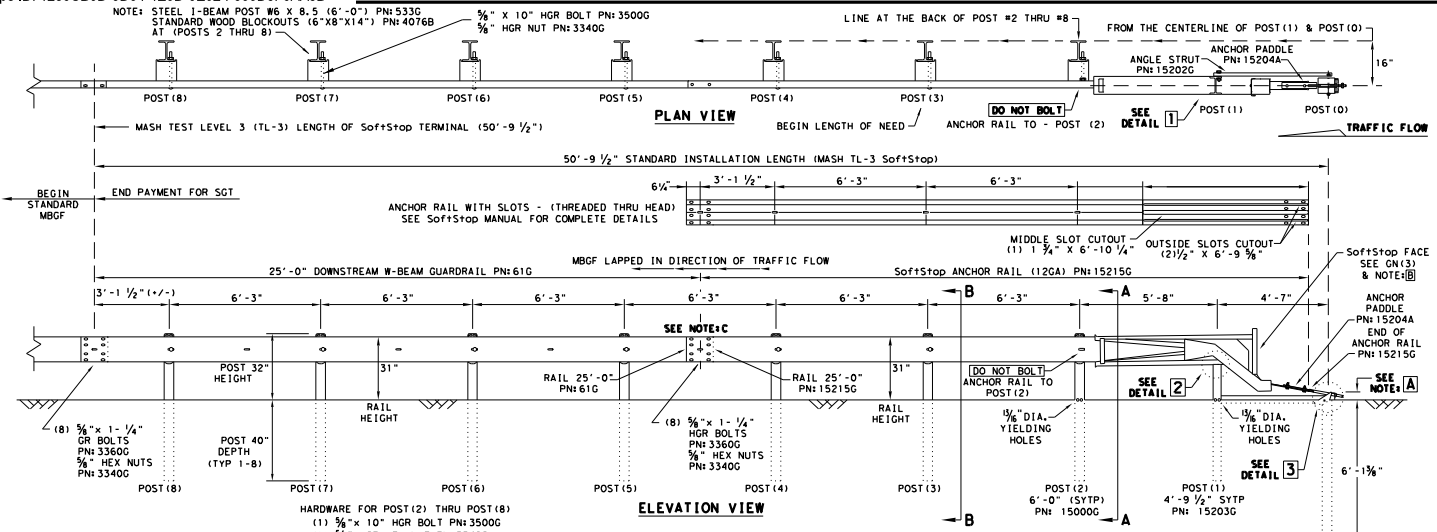

- ### GENERAL NOTES
- FOR SPECIFIC INFORMATION REGARDING INSTALLATION AND TECHNICAL GUIDANCE OF THE SYSTEM, CONTACT: TRINITY HIGHWAY AT 1(888)323-6374, 2525 N. STEMMONS FREEWAY, DALLAS, TX 75207
 - FOR INSTALLATION, REPAIR AND MAINTENANCE REFER TO THE SoftStop END TERMINAL, PRODUCT DESCRIPTION ASSEMBLY MANUAL. PN:620237B
 - APPLY HIGH INTENSITY REFLECTIVE SHEETING. OBJECT MARKERS ON THE FRONT FACE OF THE DEVICE PER MANUFACTURER'S RECOMMENDATIONS. OBJECT MARKER SHALL CONFORM TO THE STANDARDS REQUIRED IN TEXAS MUTCD.
 - FOR POST (LEAVE-OUT) INSTALLATION AND GUIDANCE SEE TXDOT'S LATEST ROADWAY MOW STRIP STANDARD.
 - HARDWARE (BOLTS, NUTS, & WASHERS) SHALL BE GALVANIZED IN ACCORDANCE WITH ITEM 445, "GALVANIZING". FITTINGS SHALL BE SUBSIDIARY TO THE BID ITEM.
 - A COMPOSITE MATERIAL BLOCKOUT THAT MEETS THE REQUIREMENTS OF DMS-7210, MAY BE SUBSTITUTED FOR BLOCKOUTS OF SIMILAR DIMENSIONS. SEE CONSTRUCTION DIVISION MATERIAL PRODUCER LIST (MPL) FOR CERTIFIED PRODUCERS.
 - IF SOLID ROCK IS ENCOUNTERED SEE THE MANUFACTURER'S INSTALLATION MANUAL AND REFER TO THE LATEST ROADWAY MBGF STANDARD FOR INSTALLATION GUIDANCE.
 - POSTS SHALL NOT BE SET IN CONCRETE.
 - IT IS ACCEPTABLE TO INSTALL THE SoftStop IMPACT HEAD PARALLEL TO THE GRADE LINE OR WITH AN UPWARD TILT.
 - DO NOT ATTACH THE SoftStop SYSTEM DIRECTLY TO A RIGID BARRIER.
 - UNDER NO CIRCUMSTANCES SHALL THE GUARDRAIL WITHIN THE SoftStop SYSTEM BE CURVED.
 - A FLARE RATE OF UP TO 25:1 MAY BE USED TO PREVENT THE TERMINAL HEAD FROM ENCRUISING ON THE SHOULDER. THE FLARE MAY BE DECREASED OR ELIMINATED FOR SPECIFIC INSTALLATIONS, IF DIRECTED BY THE ENGINEER.

- NOTE A:** THE INSTALLATION HEIGHT OF FULLY ASSEMBLED ANCHOR POST WILL VARY FROM 3'-3/4" MIN. TO 4" MAX. ABOVE FINISHED GRADE.
- NOTE B:** PART PN:5852B RIGHT-SIDE (HIGH INTENSITY REFLECTIVE SHEETING) PART PN:5851B LEFT-SIDE (HIGH INTENSITY REFLECTIVE SHEETING)
- NOTE C:** W-BEAM SPLICE LOCATED BETWEEN LINE POST (4) AND LINE POST (5) GUARDRAIL PANEL 25'-0" PN:61G ANCHOR RAIL 25'-0" PN:15215G LAP GUARDRAIL IN DIRECTION OF TRAFFIC FLOW.

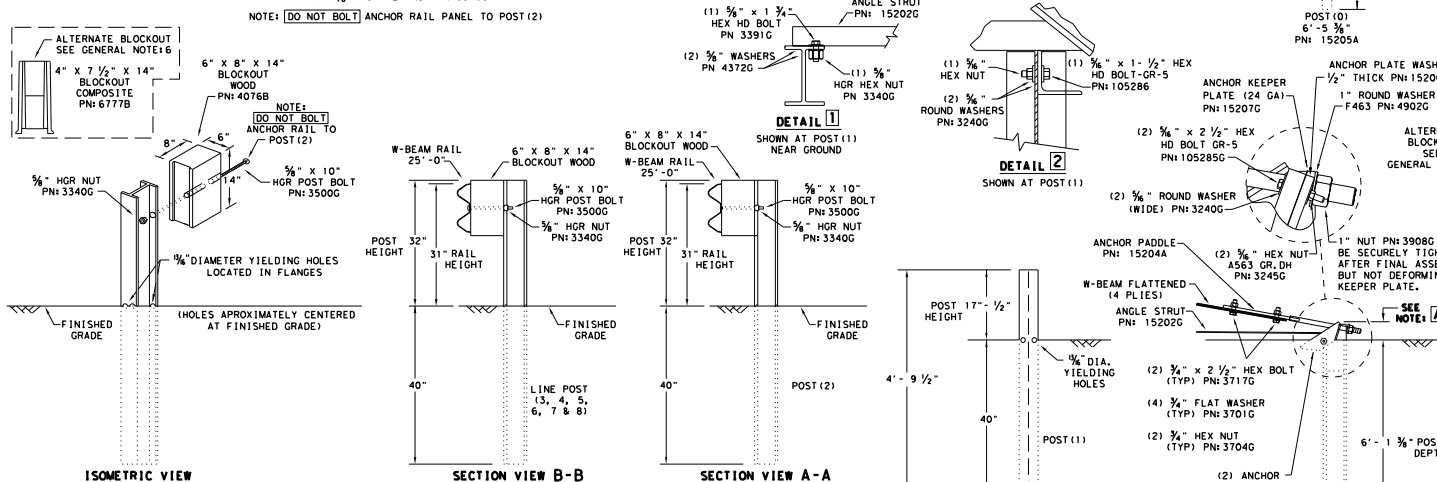

PART	QTY	MAIN SYSTEM COMPONENTS
620237B	1	PRODUCT DESCRIPTION ASSEMBLY MANUAL (LATEST REV.)
15208A	1	SoftStop HEAD (SEE MANUAL FOR RIGHT-LEFT APPROACH)
15215G	1	SoftStop ANCHOR RAIL (12GA) WITH CUTOUT SLOTS
61G	1	SoftStop DOWNSTREAM W-BEAM RAIL (12GA) (25'-0")
15205A	1	POST #0 - ANCHOR POST (6'-5 3/4")
15203G	1	POST #1 - (SYTP) (4'-9 1/2")
15000G	1	POST #2 - (SYTP) (6'-0")
533G	6	POST #3 THRU #8 - I-BEAM (W6 X 8.5) (6'-0")
4076B	7	BLOCKOUT - WOOD (ROUTED) (6" X 8" X 14")
6777B	7	BLOCKOUT - COMPOSITE (4" X 7 1/2" X 14")
15204A	1	ANCHOR PADDLE
15207G	1	ANCHOR KEEPER PLATE (24 GA)
15206G	1	ANCHOR PLATE WASHER (1/2" THICK)
15201G	2	ANCHOR POST ANGLE (10" LONG)
15202G	1	ANGLE STRUT
HARDWARE		
4902G	1	1" ROUND WASHER F436
3908G	1	1" HEAVY HEX NUT A563 GR, DH
3717G	2	3/4" X 2 1/2" HEX BOLT A325
3701G	4	3/4" ROUND WASHER F436
3704G	2	3/4" HEAVY HEX NUT A563 GR, DH
3360G	16	3/8" X 1 1/4" W-BEAM RAIL SPLICE BOLTS HGR
3340G	25	3/4" W-BEAM RAIL SPLICE NUTS HGR
3500G	7	3/8" X 10" HGR POST BOLT A307
3391G	1	3/8" X 1 3/4" HEX HD BOLT A325
4489G	1	3/8" X 9" HEX HD BOLT A325
4372G	4	3/4" WASHER F436
105285G	2	3/4" X 2 1/2" HEX HD BOLT GR-5
105286G	1	3/4" X 1 1/2" HEX HD BOLT GR-5
3240G	6	3/4" ROUND WASHER (WIDE)
3245G	3	3/4" HEX NUT A563 GR, DH
5852B	1	HIGH INTENSITY REFLECTIVE SHEETING - SEE NOTE B

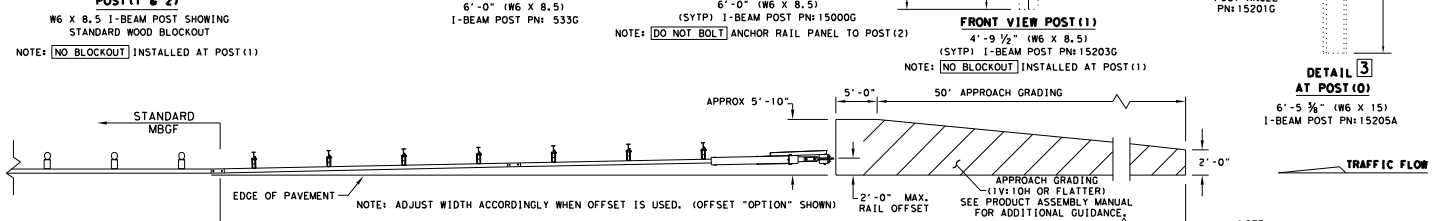

**TRINITY HIGHWAY
SOFTSTOP END TERMINAL
MASH - TL-3
SGT (10S) 31-16**

FILE: sgt10s3116	DN: TxDOT	CR: KM	DN: VP	CR: MB/VP
REVISIONS	CONT	SECT	JOB	HIGHWAY
641738	001		US 96, etc.	
DIST	COUNTY		SHEET NO.	
LFK	Son Augustine		38	

NOTE: THIS STANDARD IS A BASIC REPRESENTATION OF THE SoftStop END TERMINAL. IT IS NOT INTENDED TO REPLACE THE PRODUCT DESCRIPTION ASSEMBLY MANUAL.

DISCLAIMER: THIS STANDARD IS GOVERNED BY THE "TEXAS ENGINEERING PRACTICE ACT". NO WARRANTY OF ANY KIND IS MADE BY TXDOT FOR ANY PURPOSE WHATSOEVER. TXDOT ASSUMES NO RESPONSIBILITY FOR THE CONVERSION OF THIS STANDARD TO OTHER FORMATS OR FOR INCORRECT RESULTS OR DAMAGES RESULTING FROM ITS USE.

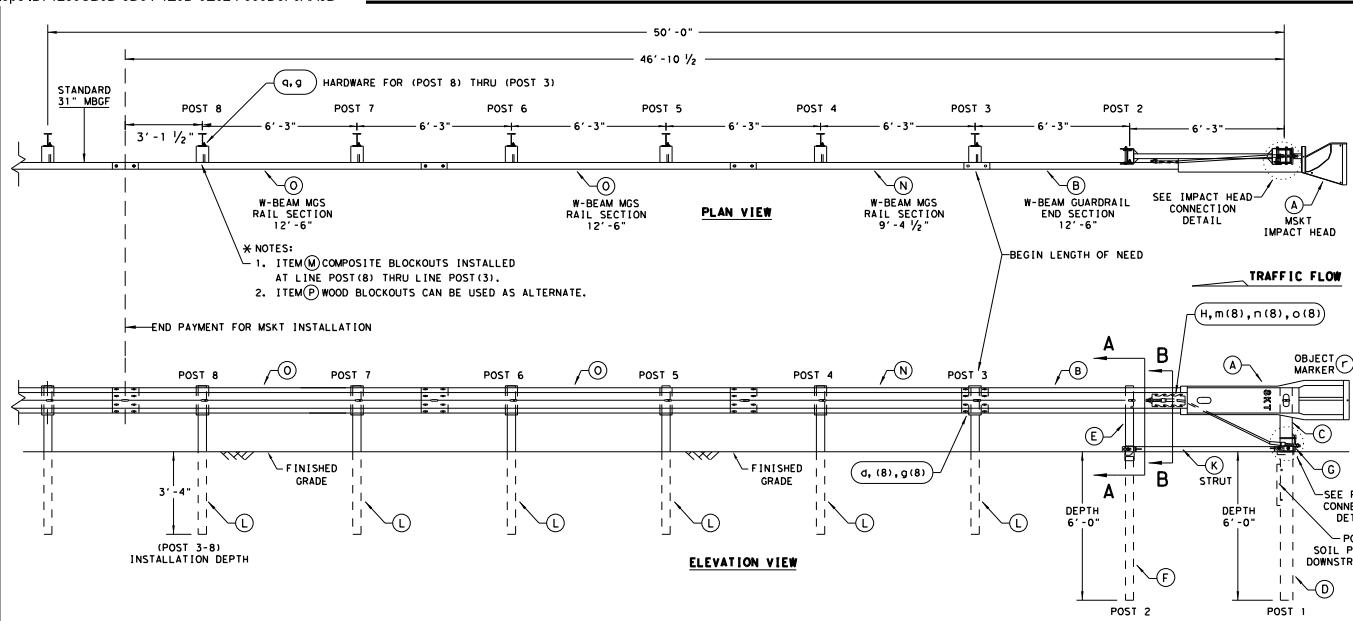

- GENERAL NOTES**
- FOR SPECIFIC INFORMATION REGARDING INSTALLATION AND TECHNICAL GUIDANCE OF THE SYSTEM, CONTACT: ROAD SYSTEMS, INC. (432)263-2435. 3616 OLD HOWARD COUNTY AIRPORT, BIG SPRING, TX 79720
 - FOR INSTALLATION, REPAIR AND MAINTENANCE REFER TO THE: MSKT END TERMINAL, PRODUCT DESCRIPTION ASSEMBLY MANUAL (PUBLICATION-062717).
 - APPLY HIGH INTENSITY REFLECTIVE SHEETING, "OBJECT MARKER" ON THE FRONT FACE OF THE DEVICE PER MANUFACTURER'S RECOMMENDATIONS. OBJECT MARKER SHALL CONFORM TO THE STANDARDS REQUIRED IN TEXAS MUTCD.
 - FOR POST (LEAVE-OUT) INSTALLATION AND GUIDANCE SEE TXDOT'S LATEST ROADWAY MOW STRIP STANDARD.
 - HARDWARE (BOLTS, NUTS, & WASHERS) SHALL BE GALVANIZED IN ACCORDANCE WITH ITEM 445, "GALVANIZING". FITTINGS SHALL BE SUBSIDIARY TO THE BID ITEM.
 - SYSTEM SHOWN USING STEEL WIDE FLANGE POSTS WITH COMPOSITE BLOCKOUTS.
 - A COMPOSITE MATERIAL BLOCKOUTS THAT MEETS THE REQUIREMENTS OF DMS-7210, MAY BE SUBSTITUTED FOR BLOCKOUTS OF SIMILAR DIMENSIONS. SEE CONSTRUCTION DIVISION MATERIAL PRODUCER LIST (MPL) FOR CERTIFIED PRODUCERS.
 - IF SOLID ROCK IS ENCOUNTERED IN THE AREA OF (POST 1) AND / OR (POST 2) CONTACT THE MANUFACTURER, & REFER TO THE LATEST ROADWAY MBGF STANDARD FOR INSTALLATION GUIDANCE.
 - POSTS SHALL NOT BE SET IN CONCRETE.
 - SYSTEM MUST BE ATTACHED TO STANDARD 31" MBGF.
 - UNDER NO CIRCUMSTANCES SHALL THE GUARDRAIL WITHIN THE MSKT SYSTEM BE CURVED.
 - A FLARE RATE OF UP TO 25:1 MAY BE USED TO PREVENT THE TERMINAL HEAD FROM ENCRANCHING ON THE SHOULDER, THE FLARE MAY BE DECREASED OR ELIMINATED FOR SPECIFIC INSTALLATIONS, IF DIRECTED BY THE ENGINEER.
 - THE SYSTEM IS SHOWN WITH TWO 12'-6" MBGF PANELS, ONE 25'-0" MBGF PANEL IS ALSO ALLOWED IN THEIR PLACE.
 - A DRIVING CAP WITH A TIMBER OR PLASTIC INSERT SHALL BE USED WHEN DRIVING POSTS 3-8 TO PREVENT DAMAGE TO THE GALVANIZING ON TOP OF THE POST. SPECIAL DRIVING CAP TO BE USED ON LOWER POSTS 1 & 2 TO PREVENT DAMAGE TO THE WELDED PLATES.

ITEM	QTY	MAIN SYSTEM COMPONENTS	ITEM NUMBERS
A	1	MSKT IMPACT HEAD	MS3000
B	1	W-BEAM GUARDRAIL END SECTION, 12 Gg.	SF1303
C	1	POST 1 - TOP (6" X 6" X 1/4" TUBE)	MTPHP1A
D	1	POST 1 - BOTTOM (6" W6X15)	MTPHP1B
E	1	POST 2 - ASSEMBLY TOP	UHP2A
F	1	POST 2 - ASSEMBLY BOTTOM (6" W6X9)	HP2B
G	1	BEARING PLATE	E750
H	1	CABLE ANCHOR BOX	S760
J	1	BCT CABLE ANCHOR ASSEMBLY	E770
K	1	GROUND STRUT	MS785
L	6	W6x9 OR W6x8.5 STEEL POST	CP21
M	6	COMPOSITE BLOCKOUTS	CBSP-14
N	1	W-BEAM MGS RAIL SECTION (9'-4 1/2")	G12025
O	2	W-BEAM MGS RAIL SECTION (12'-6")	G1203A
P	6	WOOD BLOCKOUT 6" X 8" X 14"	P675
Q	1	W-BEAM MGS RAIL SECTION (25'-0")	G1209

SMALL HARDWARE			
o	2	3/8" x 1" HEX BOLT (GRD 5)	B5160104A
b	4	3/8" WASHER	W0516
c	2	3/8" HEX NUT	N0516
d	25	3/8" Dia. x 1 1/4" SPLICE BOLT (POST 2)	B580122
e	2	3/8" Dia. x 9" HEX BOLT (GRD A449)	B580904A
f	3	3/8" WASHER	W050
g	33	3/8" Dia. H.G.R. NUT	N050
h	1	3/4" Dia. x 8 1/2" HEX BOLT (GRD A449)	B340854A
j	1	3/4" Dia. HEX NUT	N030
k	2	1 ANCHOR CABLE HEX NUT	N100
l	2	1 ANCHOR CABLE WASHER	W100
m	8	1/2" x 1 1/4" A325 BOLT WITH CAPTIVE WASHER	SB12A
n	8	1/2" STRUCTURAL NUTS	NO12A
o	8	1 1/4" O.D. x 3/8" I.D. STRUCTURAL WASHERS	WO12A
d	1	BEARING PLATE RETAINER TIE	CT-1005T
q	6	3/4" x 10" H.G.R. BOLT	B581002
r	1	OBJECT MARKER 18" X 18"	E3151

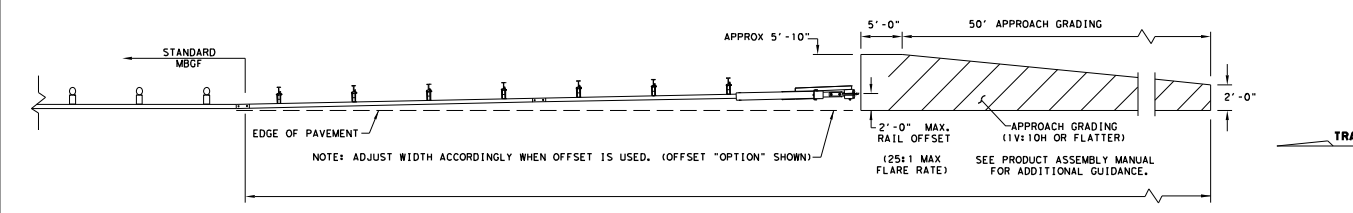
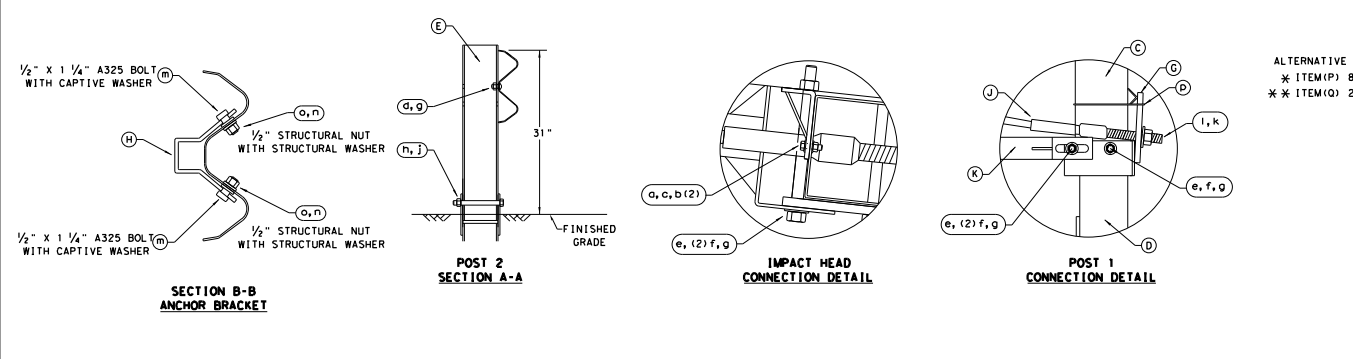

Texas Department of Transportation

Design Division Standard

SINGLE GUARDRAIL TERMINAL

MSKT-MASH-TL-3

SGT (12S) 31-18

FILE: sgt12s3118.dgn DWT:DOT CK:KM DW:VP CK:CL

© TXDOT: APRIL 2018 CONT:SECT JOB: HIGHWAY:

REVISIONS

6417	38	001	US 96, etc.
DIST	COUNTY	SHEET NO.	
LFK	San Augustine	39	

DISCUSS W/CR THIS STANDARD IS COVERED BY THE "TEXAS ENGINEERING PRACTICE ACT". NO WARRANTY OF ANY KIND IS MADE BY TXDOT FOR ANY PURPOSE WHATSOEVER. TXDOT ASSUMES NO RESPONSIBILITY FOR THE CONVERSION OF THIS STANDARD TO OTHER FORMATS OR FOR INCORRECT RESULTS OR DAMAGES RESULTING FROM ITS USE.

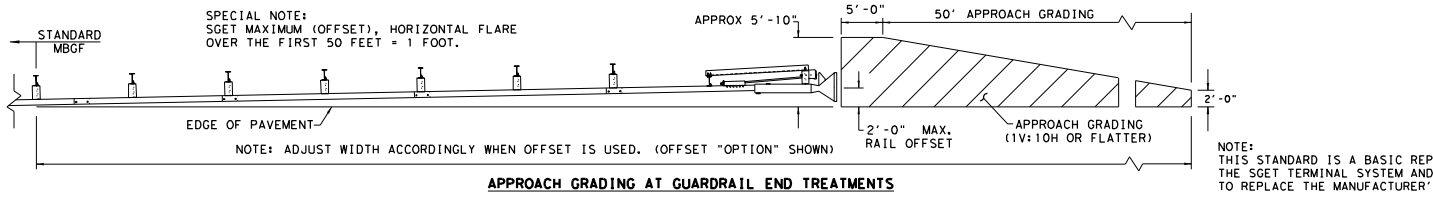
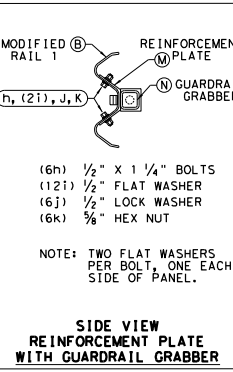
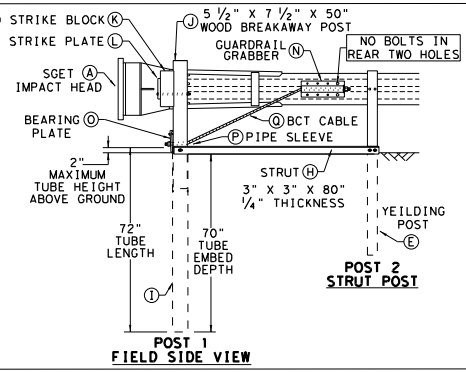
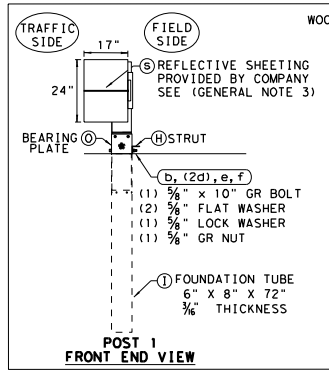
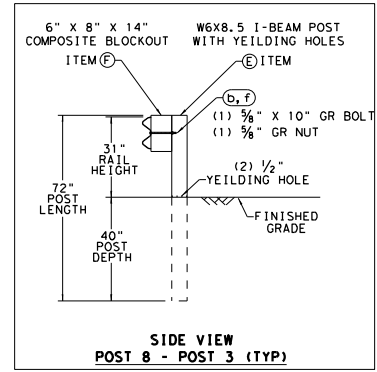
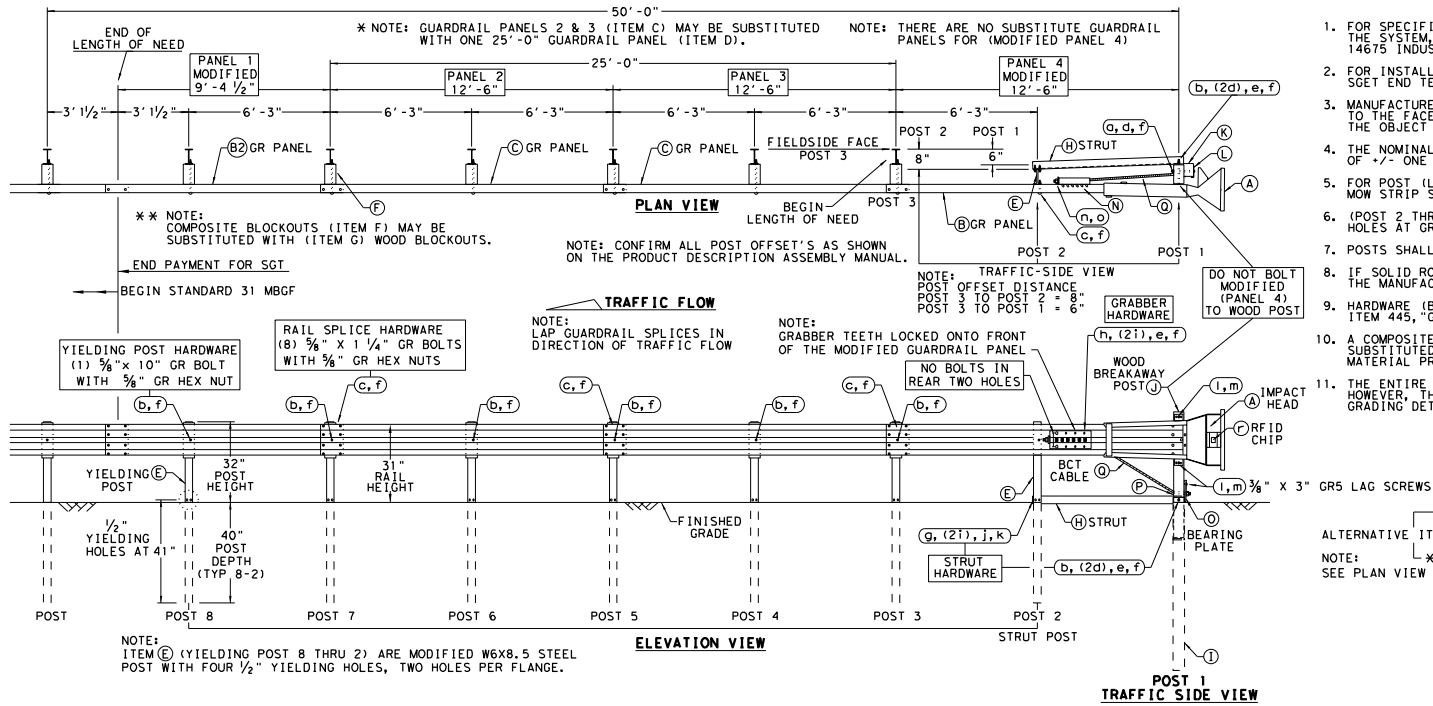

- GENERAL NOTES**
- FOR SPECIFIC INFORMATION REGARDING INSTALLATION AND TECHNICAL GUIDANCE OF THE SYSTEM, CONTACT: SPIG INDUSTRY, INC. AT 1(267) 644-9510. 14675 INDUSTRIAL PARK RD; BRISTOL, VA 24202
 - FOR INSTALLATION, REPAIR AND MAINTENANCE REFER TO THE MANUFACTURER'S SGT END TERMINAL, PRODUCT DESCRIPTION ASSEMBLY MANUAL.
 - MANUFACTURER WILL APPLY HIGH INTENSITY REFLECTIVE SHEETING, "OBJECT MARKER" TO THE FACE PLATE OF THE DEVICE PER MANUFACTURER'S RECOMMENDATIONS. THE OBJECT MARKER SHALL CONFORM TO THE STANDARDS REQUIRED IN TEXAS MUTCO.
 - THE NOMINAL HEIGHT OF THE GUARDRAIL BEAM IS 31 INCHES WITH A TOLERANCE OF +/- ONE INCH.
 - FOR POST (LEAVE-OUT) INSTALLATION AND GUIDANCE SEE TXDOT'S LATEST ROADWAY MOW STRIP STANDARD.
 - (POST 2 THROUGH POST 8) ARE MODIFIED STEEL-YIELDING POSTS WITH YIELDING HOLES AT GROUND LEVEL. THERE ARE NO SUBSTITUTE POSTS.
 - POSTS SHALL NOT BE SET IN CONCRETE.
 - IF SOLID ROCK IS ENCOUNTERED FOR ANY OF THE POSTS IN THE SYSTEM, CONTACT THE MANUFACTURER FOR SPECIFIC INSTALLATION GUIDANCE.
 - HARDWARE (BOLTS, NUTS, & WASHERS) SHALL BE GALVANIZED IN ACCORDANCE WITH ITEM 445, "GALVANIZING". FITTINGS SHALL BE SUBSIDIARY TO THE BID ITEM.
 - A COMPOSITE MATERIAL BLOCKOUT THAT MEETS OMS-7210 REQUIREMENTS MAY BE SUBSTITUTED FOR AN APPROVED WOOD BLOCKOUT. SEE CONSTRUCTION DIVISION MATERIAL PRODUCER LIST (MPL) FOR CERTIFIED PRODUCERS.
 - THE ENTIRE SYSTEM MUST BE INSTALLED IN A STRAIGHT LINE WITHOUT ANY CURVE. HOWEVER, THE SYSTEM CAN BE OFFSET BY TWO FEET AS SHOWN ON THE APPROACH GRADING DETAIL TO HELP OFF-SET THE IMPACT HEAD FROM SHOULDER OF THE ROAD.

ITEM	QTY	MAIN SYSTEM COMPONENTS	ITEM #
A	1	SGT IMPACT HEAD	SIH1A
B	1	MODIFIED GUARDRAIL PANEL 12'-6"	126SP2GP
B2	1	MODIFIED GUARDRAIL PANEL 9'-4 1/2"	GP94
C	2	STANDARD GUARDRAIL PANEL 12'-6"	GP126
D	1	STANDARD GUARDRAIL PANEL 25'-0"	GP25
E	7	MODIFIED YIELDING I-BEAM POST W6x8.5	YPMOD
F	6	COMPOSITE BLOCKOUT 6" x 8" x 14"	CB08
G	6	WOOD BLOCKOUT 6" x 8" x 14"	WB08
H	1	STRUT 3" x 3" x 80" x 1/4" A36 ANGLE	STR80
I	1	FOUNDATION TUBE 6" x 8" x 72" x 3/8"	FND16
J	1	WOOD BREAKAWAY POST 5 1/2" x 7 1/2" x 50"	WBRK50
K	1	WOOD STRIKE BLOCK	WSBK14
L	1	STRIKE PLATE 1/4" A36 BENT PLATE	SPL18
M	1	REINFORCEMENT PLATE 12 GA. GR55	REPL117
N	1	GUARDRAIL GRABBER 2 1/2" x 2 1/2" x 16 1/2"	GRG17
O	1	BEARING PLATE 8" x 6 3/8" x 3/8" A36	BPL18
P	1	PIPE SLEEVE 4 1/2" x 2 3/8" O.D. (2 1/8" I.D.)	PSLV4
Q	1	BCT CABLE 3/2" x 81" LENGTH	CB181

SMALL HARDWARE			
Q	1	5/8" x 12" GUARDRAIL BOLT 307A HDG	12GRBLT
D	7	3/8" x 10" GUARDRAIL BOLT 307A HDG	10GRBLT
C	33	3/8" x 1 1/2" GR SPLICE BOLTS 307A HDG	1GRBLT
D	3	FLAT WASHER F436 A325 HDG	58FW436
e	1	LOCK WASHER HDG	58LW
f	39	GUARDRAIL HEX NUT HDG	58HN563
Q	2	1/2" x 2" STRUT BOLT A325 HDG	2BLT
n	6	1/2" x 1 1/2" PLATE BOLT A325 HDG	125BLT
i	16	1/2" FLAT WASHER F436 A325 HDG	125FW436
j	8	1/2" LOCK WASHER HDG	12LW
k	8	1/2" HEX NUT A563 HDG	12HN563
l	4	3/8" x 3" HEX LAG SCREW GR5 HDG	38LS
m	4	3/8" FLAT WASHER F436 A325 HDG	38FW844
n	2	1" FLAT WASHER F436 A325 HDG	1FW436
o	2	1" HEX NUT A563HDG	1HN563
D	1	18" TO 24" LONG ZIP TIE RATED 175-200LB	ZPT18
q	1	1 1/2" x 4" SCH-40 PVC PIPE	PSPCR4
r	1	RFID CHIP RATED MIL-STD-810F	RFID810F
s	1	IMPACT HEAD REFLECTIVE SHEETING	RS30M

Texas Department of Transportation

Design Division Standard

SPIG INDUSTRY, LLC

SINGLE GUARDRAIL TERMINAL

SGT - TL-3 - MASH

SGT (15) 31-20

FILE: g0153120.dgn	DN: TXDOT	CK: KM	DR: VP	CK: VP
REVISIONS	CONT	SECT	JOB	HIGHWAY
TXDOT: APRIL 2020	6417	38	001	US 96, etc.
	DIST	COUNTY		SHEET NO.
	LFK	San Augustine		40

DISCLAIMER: The use of this standard is governed by the "Texas Engineering Practice Act". No warranty of any kind is made by TxDOT for any purpose whatsoever. TxDOT assumes no responsibility for the conversion of this standard to other formats or for incorrect results or damages resulting from its use.

DATE: 11/17/2022
 FILE: T:\LFDKDM\Main\ Contracts\0.RMC - Routine Maintenance Contracts\1723 Plans\6417-38-001 San Augustine MBGF\DDN\STANDARD\MBGF STD\CCCC-22.dgn

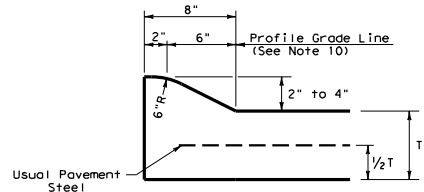

**TYPE I CURB (MONOLITHIC)
2" - 4" HEIGHT**

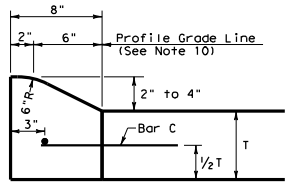

**TYPE I CURB
2" - 4" HEIGHT**

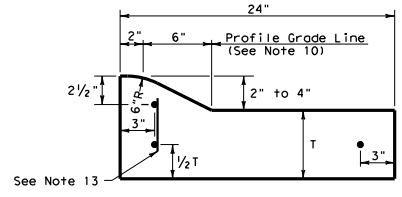

**TYPE I CURB AND GUTTER
2" - 4" HEIGHT**

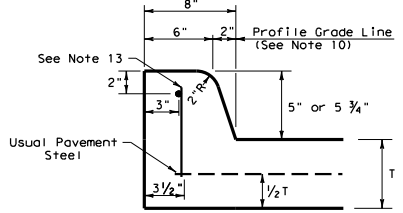

**TYPE II CURB (MONOLITHIC)
5" - 5 3/4" HEIGHT**

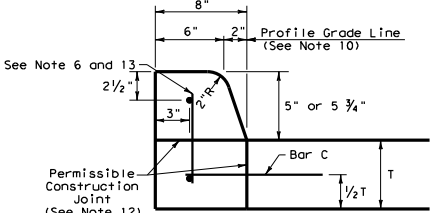

**TYPE II CURB
5" - 5 3/4" HEIGHT**

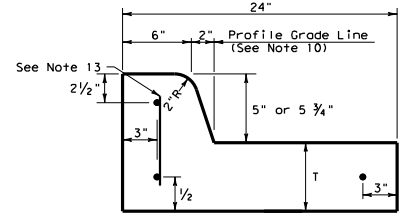

**TYPE II CURB AND GUTTER
5" - 5 3/4" HEIGHT**

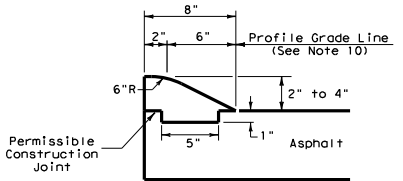

**TYPE III CURB (KEYED)
2" - 4" HEIGHT**

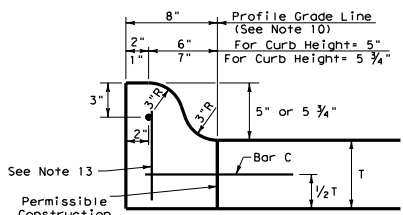

**TYPE IIa CURB
5" - 5 3/4" HEIGHT**

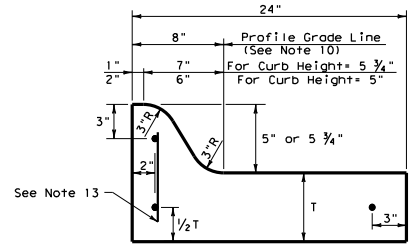

**TYPE IIa CURB AND GUTTER
5" - 5 3/4" HEIGHT**

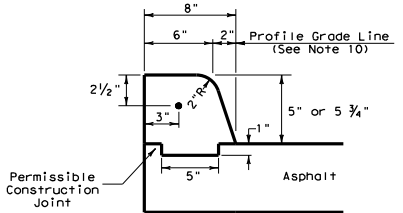

**TYPE IV CURB (KEYED)
5" - 5 3/4" HEIGHT**

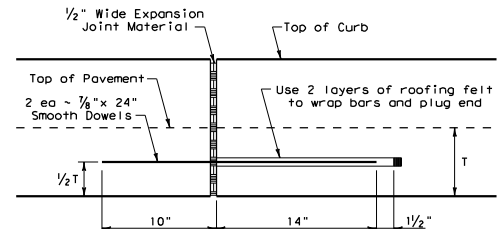

EXPANSION JOINT DETAIL

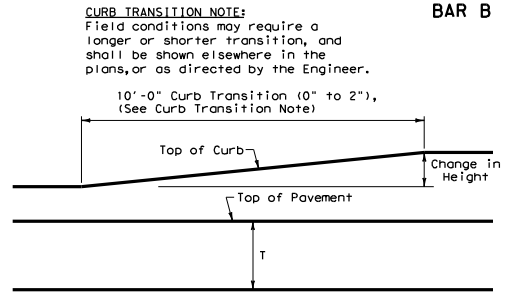

CURB TRANSITION
Note: To be paid for as Highest Curb

GENERAL NOTES

- All materials and construction shall be in accordance with Item 529, "Concrete Curb, Gutter, and Combined Curb and Gutter."
- Concrete shall be Class A.
- When reinforcing bars are used, they shall be No.4 unless otherwise shown. The use of fiber reinforced concrete in lieu of reinforcing steel is acceptable. Use fibers meeting the requirements of DMS 4550, "Fibers for Concrete," and dose fibers in accordance with Material Producers List (MPL) "Fibers for Class A and B Concrete Applications."
- Round exposed sharp edges with a rounding tool, to a minimum radius of 1/4 inch.
- All existing curbs and driveways to be removed shall be sawed or removed at existing joints.
- Where concrete curb is to be placed on existing concrete pavement, Bar B may be drilled and grouted in place, or may be inserted into fresh concrete.
- Expansion and contraction joints shall be constructed to match pavement joints in all curbs and curb and gutter adjacent to jointed concrete pavement. Where placement of curb or curb and gutter is not adjacent to concrete pavement, expansion joints shall be provided at structures, curb returns at streets, and at locations directed by The Engineer.
- Vertical and horizontal dowel bars and transverse reinforcing bars shall be placed at four feet C-C.
- Dimension 'T' shown is the thickness of concrete pavement. When curb is installed adjacent to flexible pavement dimension 'T' is 8" maximum.
- Usual profile grade line. Refer to typical sections and plan-profile sheets for exact locations.
- One-half inch expansion joint material shall be provided where curb or curb and gutter is adjacent to sidewalk or riprap.
- When horizontal permissible construction joints are used, the longitudinal pavement steel shall be placed in accordance with pavement details shown elsewhere in the plans. Reinforcing steel for curb section shall then conform to that required for concrete curb.
- Bar B placement as needed (typically at four ft. C-C) to support curb reinforcing steel during concrete placement.

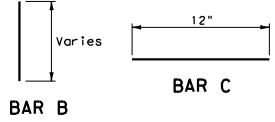

CURB TRANSITION NOTE:
Field conditions may require a longer or shorter transition, and shall be shown elsewhere in the plans, or as directed by the Engineer.

		Design Division Standard	
CONCRETE CURB AND GUTTER			
CCCC-22			
FILE: cccg21.dgn	DN: TXDOT	CR: AN	DR: CS
© TXDOT: JUNE 2022	CONT SECT	JOB	HIGHWAY
REVISIONS	6417	38	001
	DIST	COUNTY	US 96, etc.
	LFK	San Augustine	SHEET NO. 41

DISCLAIMER: The use of this standard is governed by the "Texas Engineering Practice Act". No warranty of any kind is made by TxDOT for any purpose whatsoever. TxDOT assumes no responsibility for the conversion of this standard to other formats or for incorrect results or damages resulting from its use.

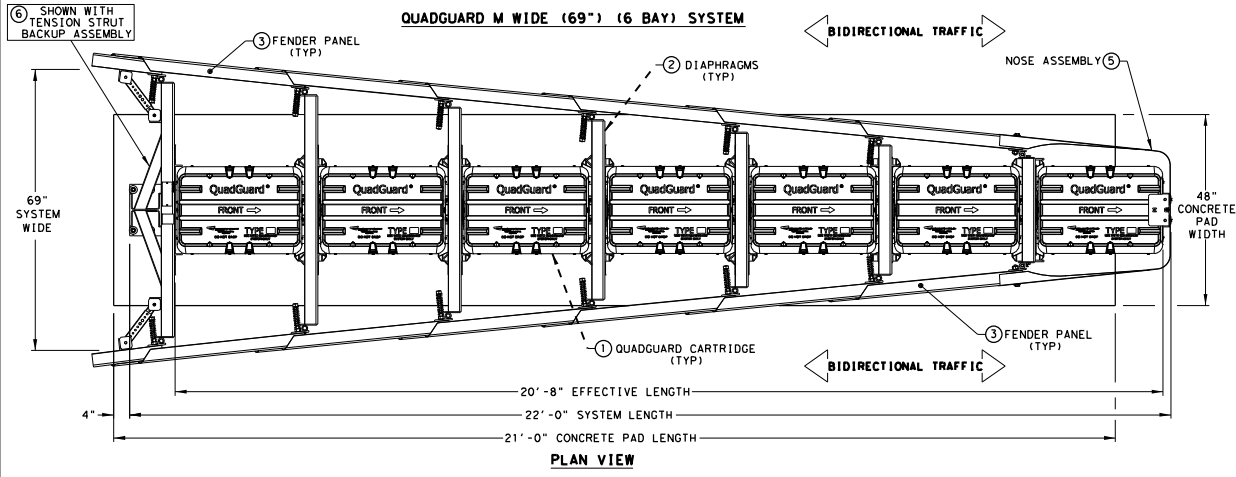

KEY	DESCRIPTION	KEY	DESCRIPTION
1	QUADGUARD CARTRIDGE	5	NOSE ASSEMBLY
2	DIAPHRAGM	6	TYPE OF BACKUP
3	FENDER PANEL	7	REINFORCED CONCRETE FOUNDATION PAD
4	MONORAIL		

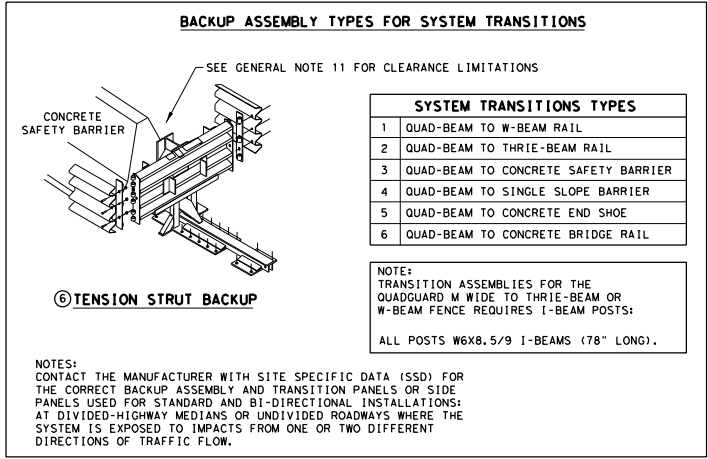
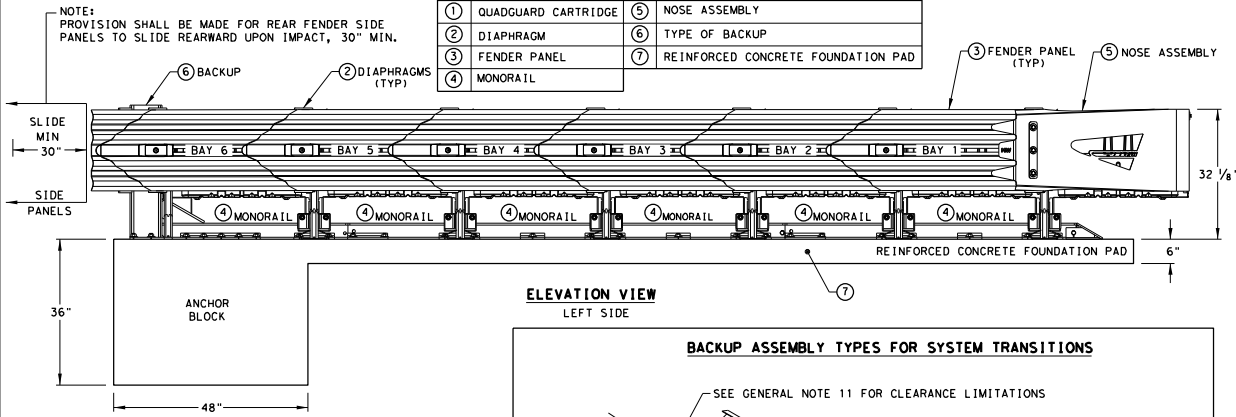

NOTES:
 CONTACT THE MANUFACTURER WITH SITE SPECIFIC DATA (SSD) FOR CONCRETE PAD AND ANCHOR BLOCK INSTALLATION REQUIREMENTS.
 A MANUFACTURER'S DRAWING PACKAGE UNIQUE AND SPECIFIC FOR THE QUADGUARD M WIDE FIELD INSTALLATION AND INFORMATION REGARDING THE TYPE OF BACKUP ASSEMBLY REQUIRED FOR THE TRANSITION WILL BE PROVIDED BY THE MANUFACTURER TO THE ENGINEER AND INSTALLER.
 6" REINFORCED CONCRETE PAD REQUIRES THE INSTALLATION OF AN ANCHOR BLOCK AS SHOWN ON THE MANUFACTURER'S DRAWING PACKAGE.
 8" NON-REINFORCED CONCRETE PAD MAY NOT REQUIRE AN ANCHOR BLOCK, IF THE PAD IS INSTALLED AGAINST AN IMMOVABLE CONCRETE BACKUP.
 CONCRETE PAD AND ANCHOR BLOCK COMBINATIONS SHALL BE CONFIRMED WITH THE MANUFACTURER BASED UPON SITE SPECIFIC DATA (SSD).

NOTE:
 THE QUADGUARD M WIDE 6-BAY SYSTEM TESTED TO MASH TL-3.

TL-3 MODEL#	QM10069 (627515)	CARTRIDGE TYPES IN BAYS	
BAYS	6	TYPE I	TYPE II
DIAPHRAGMS	6	4	3
WIDTH	69"	REAR	FRONT

GENERAL NOTES

- FOR SPECIFIC INFORMATION REGARDING INSTALLATION AND TECHNICAL GUIDANCE OF THE SYSTEM, CONTACT: TRINITY HIGHWAY - ENERGY ABSORPTION INC. AT 1(888)323-6374 OR WEBSITE www.trinityhighway.com.
- SEE THE RECENT QUADGUARD M WIDE PRODUCT DESCRIPTION ASSEMBLY MANUAL FOR IMPACT PERFORMANCE CHARACTERISTICS AND DESIGN LIMITATIONS AND THE DRAWING PACKAGE FOR THE 51X (6) BAY WIDE (69") SYSTEM BEFORE INSTALLING THE QUADGUARD M WIDE AT ANY GIVEN LOCATION.
- COMPONENTS FOR THE QUADGUARD M WIDE BACKUP AND REINFORCING DETAILS ARE SHOWN ON THE QUADGUARD M WIDE PRODUCT DESCRIPTION & ASSEMBLY MANUAL.
- THE INSTALLATION AREA SHOULD BE FREE OF CURBS, ELEVATED OBJECTS, OR DEPRESSIONS.
- FOR PERMANENT APPLICATIONS, QUADGUARD M WIDE SHOULD BE ASSEMBLED ON AN EXISTING OR FRESHLY PLACED AND CURED CONCRETE BASE 28MPa (4,000 PSI) MINIMUM. QUADGUARD M WIDE SYSTEM MAY ALSO BE ASSEMBLED ON REINFORCED OR NON-REINFORCED CONCRETE ROADWAY (MINIMUM 8" THICK).
- CONCRETE PAD SHALL BE 6" MIN. REINFORCED 28MPa (4,000 PSI) (P.C.) OR 8" MIN. NON-REINFORCED 28MPa (4,000 PSI) CONCRETE ROADWAY MEASURING AT LEAST 12'-0" WIDE BY 50'-0" LONG. ANCHOR BLOCK IS NOT REQUIRED WHEN USING 8" CONCRETE PAD INSTALLED AGAINST AN IMMOVABLE STRUCTURE, E.G. CONCRETE WALL.
- IF THE CROSS-SLOPE VARIES MORE THAN 2% OVER THE LENGTH OF THE SYSTEM, THE CONCRETE PAD WILL REQUIRE LEVELING. MAXIMUM PERMISSIBLE CROSS-SLOPE IS 8%.
- FOR BI-DIRECTIONAL TRAFFIC: THE LOCATION AND OR WIDTH OF THE QUADGUARD M WIDE IS RESTRICTED. AS BI-DIRECTIONAL TRAFFIC APPROACHES THE REAR OF THE QUADGUARD M WIDE, THE QUADGUARD M WIDE SHOULD NOT EXTEND FURTHER INTO THE TRAFFIC-SIDE OF THE BARRIER THAN THE OBSTACLE. ANY TRANSITION INSTALLED MUST EITHER BE TANGENT TO BOTH QUADGUARD M WIDE AND OBSTACLE OR MUST ANGLE TOWARD FIELD SIDE OF THE BARRIER.
- SYSTEM TRANSITION: APPROPRIATE TRANSITION PANELS OR SIDE PANELS WILL BE REQUIRED FOR PROPER IMPACT PERFORMANCE. THE CORRECT PANEL(S) TO USE WILL DEPEND ON THE DIRECTION OF TRAFFIC FLOW AND WHAT TYPE OF BARRIER OR ROAD FEATURE THE QUADGUARD M WIDE SYSTEM IS SHIELDING. SEE THE QUADGUARD M WIDE PRODUCT DESCRIPTION & ASSEMBLY MANUAL FOR FURTHER DETAILS.
- THE QUADGUARD M WIDE SYSTEM SHOULD BE INSTALLED APPROXIMATELY PARALLEL WITH THE BARRIER.
- FOR THE TENSION STRUT BACKUP, THE DISTANCE BETWEEN THE BACK OF BACKUP AND THE BARRIER WALL SHOULD NOT EXCEED 7" IN ANY CASE.
- THE WIDE QUADGUARD M WIDE SYSTEM IS ONLY AVAILABLE IN A 69" WIDTH AND HAS A 6-BAY SYSTEM THAT HAS BEEN TESTED TO MASH TEST LEVEL 3.
- IF THE OUTSIDE WIDTH OF OBSTACLE(S) BEING SHIELDED IS 53" OR GREATER, THE OUTSIDE OF OBSTACLE(S) MUST BE CHAMFERED. SEE THE QUADGUARD M WIDE PRODUCT DESCRIPTION & ASSEMBLY MANUAL FOR FURTHER DETAILS.
- SEE THE "QUADGUARD M WIDE SYSTEM PRODUCT MANUAL" FOR A DESCRIPTION OF ITS IMPACT PERFORMANCE CHARACTERISTICS AND DESIGN LIMITATIONS BEFORE PLACING A SYSTEM AT A GIVEN SITE. INFORMATION AND COPIES OF ABOVE MANUAL ARE AVAILABLE BY CALLING CUSTOMER SERVICE DEPARTMENT AT (888) 323-6374.

FOUNDATION & ANCHORING REQUIREMENTS	
FOUNDATION TYPES: A & B	
FOUNDATION TYPE:A	REINFORCED CONCRETE PAD OR ROADWAY
FOUNDATION:	6" MINIMUM DEPTH WITH ANCHOR BLOCK (P.C.C.)
ANCHORAGE:	7" STUDS EMBEDDED 5 1/2" - APPROVED ADHESIVE
FOUNDATION TYPE:B	REINFORCED OR NON-REINFORCED CONCRETE PAD OR ROADWAY
FOUNDATION:	8" MINIMUM DEPTH (P.C.C.)
ANCHORAGE:	7" STUDS EMBEDDED 5 1/2" - APPROVED ADHESIVE
KEY:	COMPACTED SUBBASE (C.S.)
	PORTLAND CEMENT CONCRETE (P.C.C.)

NOTE: SEE TRINITY'S PRODUCT DESCRIPTION ASSEMBLY MANUAL FOR THE APPROVED ADHESIVE.
 TENSION STRUT BACKUP MAY NOT BE USED IN ASPHALT CONCRETE (A.C.). SEE TRINITY'S PRODUCT DESCRIPTION ASSEMBLY MANUAL FOR MORE INFORMATION.

Texas Department of Transportation		Design Division Standard	
TRINITY HIGHWAY ENERGY ABSORPTION QUADGUARD M WIDE (MASH TL-3) OG (M) (W) - 21			
FILE#	qgm21.dgn	DN#	TxDOT
REV#	001	CR#	KM
DATE	JULY 2021	DN#	SS
COMP	6417	SECT	38
JOB	001	COUNTY	US 96, etc.
DIST	LFK	COUNTY	San Augustine
SHEET NO.			42

REUSABLE

DATE: 11/17/2022
 FILE: #FILE#

DISCLAIMER: THIS STANDARD IS COVERED BY THE "TEXAS ENGINEERING PRACTICE ACT". NO WARRANTY OF ANY KIND IS MADE BY TxDOT FOR ANY PURPOSE WHATSOEVER. TxDOT ASSUMES NO RESPONSIBILITY FOR THE CONVERSION OF THIS STANDARD TO OTHER FORMATS OR FOR INCORRECT RESULTS OR DAMAGES RESULTING FROM ITS USE.

DATE: 11/17/2022
 FILE: TL-1FKDMMWgtrntr Contracts\0-RMC - Routine Maintenance Contracts\19-23 Plans\6417-38-001 San Augustine MBGF DDN STANDARD-ROADWAY\TAU(M) (N) -19.dgn

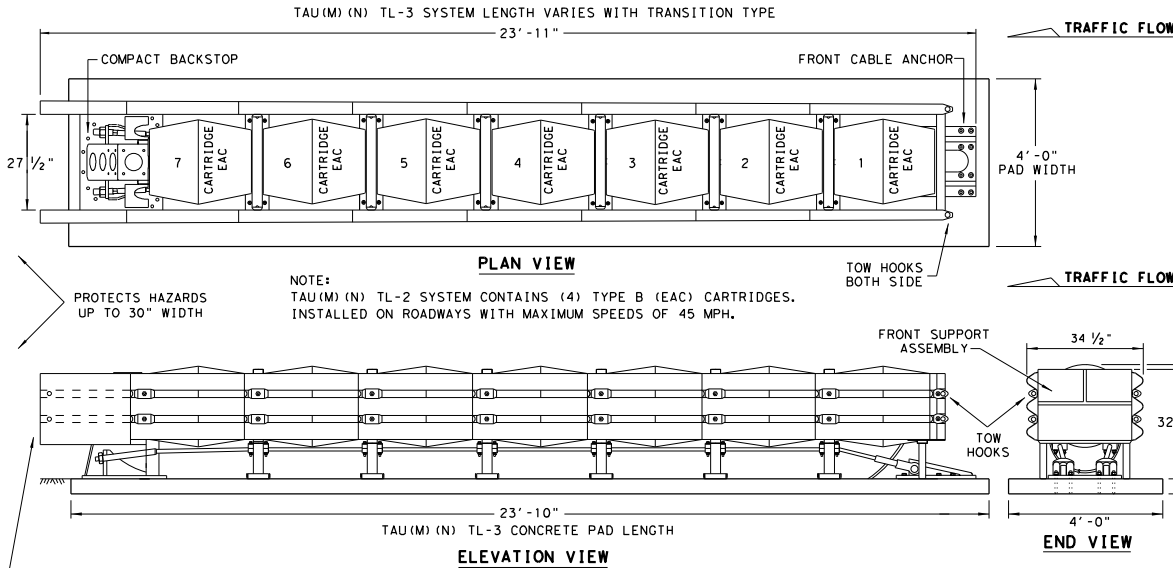

NOTES:
 TRANSITIONS AND ATTACHMENTS TO VARIOUS BARRIER SHAPES, RAILINGS AND BI-DIRECTIONAL TRAFFIC FLOWS ARE AVAILABLE. SEE MANUFACTURER'S INSTALLATION INSTRUCTIONS MANUAL FOR ADDITIONAL TRANSITION DETAILS.

NOTE:
 CONCRETE FOUNDATION PAD LENGTH VARIES WITH TL-3 AND TL-2 SYSTEMS, SEE SYSTEM & FOUNDATION LENGTH TABLE.

FOUNDATION OPTIONS	
6" REINFORCED CONCRETE	
8" UNREINFORCED CONCRETE	
ASPHALT OVER CONCRETE WITH MINIMUM 6" EMBEDMENT IN CONCRETE	
6" ASPHALT OVER 6" COMPACT SUBBASE	
8" MINIMUM ASPHALT	

SYSTEM & FOUNDATION LENGTH TABLE	
SYSTEM LENGTH	FOUNDATION LENGTH
TL-2 = 15'-5"	TL-2 = 15'-4"
TL-3 = 23'-11"	TL-3 = 23'-10"

*** NOTE:**
 REQUIRES AN ASPHALT ANCHORAGE PACKAGE: INCLUDES ADDITIONAL BRACES FOR THE FRONT CABLE ANCHOR AND THE COMPACT BACKSTOP, AND ASPHALT HARDWARE KIT. THE TL-3 ASPHALT CONFIGURATION ALSO REQUIRES NESTED SLIDER PANELS AND SHIMS AT THE LAST TWO BAYS. SEE MANUFACTURER'S INSTALLATION INSTRUCTION MANUAL FOR DETAILS.

**** NOTE:**
 ENGINEER OR CONTRACTOR SHALL COORDINATE WITH THE MANUFACTURER FOR THE CORRECT DECAL PER TRAFFIC FLOW, LEFT, RIGHT OR BOTH-SIDES.

NOTE:
 SEE MANUFACTURER'S INSTALLATION INSTRUCTION MANUAL FOR FOUNDATION SPECIFICATIONS THAT INCLUDE, STONE AGGREGATE MIX, COMPRESSION STRENGTH, STEEL SIZE, ANCHOR SIZE, AND EMBEDMENT DEPTH.

NOTE:
 DELINEATION BRACKET ATTACHES TO FRONT SUPPORT ASSEMBLY.

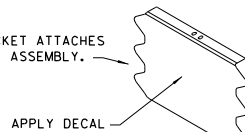

DELINEATION BRACKET

NOTE:
 APPLY A HIGH REFLECTIVE DECAL TO THE DELINEATION BRACKET. DELINEATION DECAL ORIENTATION IS SHOWN ON THE CONSTRUCTION PLAN SET AND SHALL BE IN ACCORDANCE WITH THE TEXAS MUTCD FOR (TRAFFIC CONTROL DEVICES). DECALS ARE AVAILABLE FOR TRAFFIC FLOW ON THE LEFT-SIDE, BOTH -SIDES AND RIGHT-SIDE.

TRANSITION OPTIONS	
USE THE COMPACT BACKSTOP	VERTICAL WALL
	CONCRETE TRAFFIC BARRIERS
	W-BEAM GUARDRAIL
	THRIE BEAM GUARDRAIL

NOTE:
 FOR BI-DIRECTIONAL TRANSITION PANELS AND BRIDGE RAIL END SHOE DETAILS. SEE MANUFACTURER'S INSTALLATION INSTRUCTIONS MANUAL.

GENERAL NOTES

- FOR SPECIFIC INFORMATION REGARDING THE INSTALLATION AND TECHNICAL GUIDANCE OF THE SYSTEM, CONTACT: LINDSAY TRANSPORTATION SOLUTIONS (LTS) - BARRIER SYSTEMS, INC. AT (707) 374-6800. 180 RIVER ROAD, RIO VISTA, CA 94571
- REFER TO THE LATEST (LTS) INSTALLATION INSTRUCTION MANUAL FOR IMPORTANT SAFETY MESSAGES, COMPLETE SYSTEM ASSEMBLY, AND ANCHOR INSTALLATION REQUIREMENTS FOR THE NINE (9) DIFFERENT SITE TRANSITIONS.
- INSTALLATION DETAILS FOR THE COMPACT BACKSTOP, FRONT CABLE ANCHOR AND FOUNDATION OPTIONS ARE SHOWN ON THE INSTALLATION INSTRUCTION MANUAL FURNISHED TO THE ENGINEER.
- CONCRETE SHALL BE CLASS "S" WITH A MINIMUM COMPRESSIVE STRENGTH OF 4,000 P.S.I.
- IF THE CROSS-SLOPES VARIES MORE THAN 2% OVER THE LENGTH OF THE SYSTEM, THE CONCRETE PAD WILL REQUIRE LEVELING. MAXIMUM PERMISSIBLE CROSS-SLOPE IS 8%
- THE INSTALLATION AREA SHOULD BE FREE FROM CURBS, ELEVATED OBJECTS, OR DEPRESSIONS.
- THE TAU(M) (N) SYSTEM SHOULD BE APPROXIMATELY PARALLEL WITH THE BARRIER OR CENTER LINE OF MERGING BARRIERS.
- THIS DRAWING REPRESENTS THE UNIVERSAL TAU(M) (N) TL-3 SYSTEM, A RE-DIRECTIVE NON-GATING CRASH CUSHION THAT CAN PROTECT HAZARDS UP TO 30-INCHES IN WIDTH. ALSO AVAILABLE IN TL-2 CONFIGURATION.

BILL OF MATERIALS FOR TAU(M) (N) TL-3 & TL-2 SYSTEMS		QUANTITIES	
PART NUMBER	PART DESCRIPTION	TL-3 SYSTEM	TL-2 SYSTEM
BSI-1708019-00	SLIDING PANEL GALVANIZED TAU(M) (N)	14	8
BSI-1708030-00	END PANEL, THRIE BEAM, GALV, TAU(M) (N)	2	2
BSI-1706001-00	CABLE ASSEMBLY, 7 BAY, TAU(M) (N)	2	-
BSI-1805036-00	CABLE ASSEMBLY, 4 BAY, TAU(M) (N)	-	2
BSI-1708018-00	FRONT CABLE ANCHOR	1	1
BSI-1707034-00	COMPACT BACKSTOP	1	1
B030703	MIDDLE SUPPORT ASSEMBLY	6	3
B030704	FRONT SUPPORT	1	1
B010722	ENERGY ABSORBING CARTRIDGE, TYPE B	7	4
K001005	TAU-II FRONT SUPPORT LEG KIT	1	1
BSI-1709083-KT	TETHER KIT (INCLUDES ALL HARDWARE)	1	1
BSI-1809041-KT	SLIDER KIT (INCLUDES ALL HARDWARE)	7	4
BSI-1808033-KT	CABLE GUIDE KIT (INCLUDES ALL HARDWARE)	6	3
BSI-1809040-KT	TOW HOOK KIT (INCLUDES ALL HARDWARE)	1	1
BSI-1808034-KT	DELINEATION BRACKET KIT (INCLUDES ALL HARDWARE)	1	1
BSI-1808035-KT	END PANEL MOUNT KIT (INCLUDES ALL HARDWARE)	1	1
BSI-1808036-KT	CONCRETE ANCHORING KIT	1	1
** SEE NOTE	HIGH REFLECTIVE DECAL	1	1
ECN 3883	INSTALLATION AND INSTRUCTIONS MANUAL	1	1

NOTES:
 UPGRADE KITS ARE AVAILABLE TO RETROFIT EXISTING NCHRP 350 TAU-II SYSTEMS TO MASH COMPLIANT SYSTEMS. SEE MANUFACTURER'S PRODUCT INFORMATION.

THE TAU(M) (N) UNIDIRECTIONAL SYSTEM IS FREE STANDING AND IS NOT REQUIRED TO BE CONNECTED TO THE HAZARD.

TRANSITIONS TO GUARD FENCE, BRIDGE RAILS AND ROADSIDE BARRIERS SHALL BE IN ACCORDANCE WITH TxDOT'S POLICY.

NOTE:
 THIS STANDARD IS A BASIC REPRESENTATION OF THE UNIVERSAL TAU(M) (N) SYSTEM, IT IS NOT INTENDED TO REPLACE THE INSTALLATION INSTRUCTION MANUAL.

REUSABLE

		Design Division Standard	
LINDSAY TRANSPORTATION SOLUTIONS UNIVERSAL CRASH CUSHION (MASH TL-3 & TL-2) TAU(M) (N) -19			
FILE: t0um19.dgn	DN: TxDOT	CR: KM	DN: VP
© TxDOT: APRIL 2019	CONT SECT	JOB	HIGHWAY
REVISIONS	6417 38	001	US 96, etc.
DIST	COUNTY	SHEET NO.	
LFK	San Augustine		43

DISCLAIMER: The use of this standard is governed by the "Texas Engineering Practice Act". No warranty of any kind is made by TxDOT for any purpose whatsoever. TxDOT assumes no responsibility for the conversion of units of measurements. The use of this standard is governed by the "Texas Engineering Practice Act". No warranty of any kind is made by TxDOT for any purpose whatsoever. TxDOT assumes no responsibility for the conversion of units of measurements.

REFLECTOR UNIT SIZES FOR DELINEATORS AND OBJECT MARKERS					DELINEATORS				D & OM DESCRIPTIVE CODES	
DEVICE	SIZE 1	SIZE 2	SIZE 3	SIZE 4	DEVICE	SINGLE		DOUBLE		INSTL DEL ASSM (D-XX)SZ X (XXXX)XXX(XX) NUMBER OF REFLECTORS S = Single D = Double COLOR OF REFLECTORS W = White Y = Yellow R = Red REFLECTOR UNIT SIZE 1 or 2 TYPE OF POST OR DELINEATOR WC = Wing Channel Post YFLX = Yellow Flexible Post WFLX = White Flexible Post BR = Barrier Reflector TYPE OF MOUNT GND = Embedded (drivable or set in concrete) CTB = Concrete Barrier Mount GF1 or GF2 = Guard Fence Attachment SRF = Surface Mount DIRECTION If Required BI = Bi-Directional BR = Bi-Directional with red on back
SHEETING	Yellow, White or Red Type B or C reflective sheeting				SHEETING	Yellow, White or Red Type B or C Reflective Sheeting				
NOTE	1. Size 1 and 4 - Direct applied reflective sheeting for use on flexible post (flx). 2. Size 2 and 3 - For use on wing channel (wc) post only. Use approved metal, plastic or fiberglass backplate with 17/64" mounting holes.				POST TYPE	WC	YFLX, WFLX	WC	YFLX, WFLX	
					MOUNT TYPE	GND	GND, SRF	GND	GND, SRF	

OBJECT MARKERS								D & OM DESCRIPTIVE CODES	
DEVICE	Type 1 (OM-1)	Type 2 (OM-2)			Type 3 (OM-3)			Type 4 (OM-4)	INSTL OM ASSM (OM-XX) (XXXX)XXX(XX) TYPE OF OBJECT MARKER 1, 2, 3, or 4 NUMBER OF REFLECTORS OR DIRECTION X = 3-Size 2 reflector units (Type 2 only) Y = 1-Size 3 reflector unit (Type 2 only) Z = 3-Size 1 or 1-Size 4 reflector unit (Type 2 only) L = Left Side (Type 3 Object Marker only) R = Right Side (Type 3 Object Marker only) C = Center (Type 3 Object Marker only) TYPE OF POST WC = Wing Channel Post WFLX = White Flexible Post TWT = Thin Walled Tubing TYPE OF MOUNT GND = Embedded (drivable) SRF = Surface Mount WAS = Wedge Anchor Steel WAP = Wedge Anchor Plastic DIRECTION If Required BI = Bi-Directional
SHEETING	Yellow-Type B _{FL} or C _{FL} Sheeting	Yellow - Type B or C Sheeting			Alternating acrylic black and retroreflective yellow - Type B _{FL} or C _{FL} Sheeting			Red -Type B _{FL} or C _{FL} Sheeting	
POST TYPE	TWT	WC	WC	WFLX	TWT			TWT	
MOUNT TYPE	WAS, WAP	GND	GND	GND, SRF	WAS, WAP			WAS, WAP	

DEPARTMENTAL MATERIAL SPECIFICATIONS	
FLEXIBLE DELINEATOR & OBJECT MARKER POSTS (EMBEDDED & SURFACE MOUNT TYPES)	DMS-4400
SIGN FACE MATERIALS	DMS-8300
DELINEATORS, OBJECT MARKERS AND BARRIER REFLECTORS	DMS-8600

BARRIER REFLECTORS (BRF)			CHEVRONS				ONE DIRECTION LARGE ARROW		NOTE:		
DEVICE	GF1	GF2	CTB	 W1-8				 W1-6		Delineator and object marker substrates and sign substrates shall be 0.080" Aluminum sign blank to conform to ASTM B-209 Alloy 6061-T6 or approved alternative.	
	1. Barrier reflectors shall meet the requirements of DMS 8600. 2. Approved Barrier Reflectors are listed on the "Barrier Reflectors" Material Producer List at: www.txdot.gov.			SIZE (W x L)	18" x 24" (Conventional)	24" x 30" (Conventional Oversize)	30" x 36" (Expressway)	36" x 48" (Freeway)	SIZE (W x L)		48" x 24" (Conventional)
				MOUNTING HEIGHT	4'-0" or 7'-0"		7'-0" Only		MOUNTING HEIGHT	7'-0"	
SHEETING	Yellow, White, Red			NOTE 1. CHEVRON (W1-8) signs and ONE DIRECTION LARGE ARROW (W1-6) Signs shall be installed per Sign Mounting Details (SMD) Standard Sheets and paid under Item 644 (Small Roadside Sign Assemblies). 2. When there is a need to increase conspicuity, the Texas version of the ONE DIRECTION LARGE ARROW sign (W1-9T) may be used instead of the ONE DIRECTION LARGE ARROW (W1-6).							

Traffic Safety Division Standard

DELINEATOR & OBJECT MARKER MATERIAL DESCRIPTION

D & OM(1)-20

FILE: ddm1-20.dgn	DN: TXDOT	CR: TXDOT	DN: TXDOT	CR: TXDOT
TXDOT August 2004	CONT	SECT	JOB	HIGHWAY
REVISIONS	6417	38	001	US 96, etc.
10-09 3-15	DIST	COUNTY	SHEET NO.	
4-10 7-20	LFK	San Augustine	44	

MINIMUM WARNING DEVICES AT CURVES WITH ADVISORY SPEEDS

Amount by which Advisory Speed is less than Posted Speed	Curve Advisory Speed	
	Turn (30 MPH or less)	Curve (35 MPH or more)
5 MPH & 10 MPH	• RPMs	• RPMs
15 MPH & 20 MPH	• RPMs and One Direction Large Arrow sign	• RPMs and Chevrons; or • RPMs and One Direction Large Arrow sign where geometric conditions or roadside obstacles prevent the installation of chevrons.
25 MPH & more	• RPMs and Chevrons; or • RPMs and One Direction Large Arrow sign where geometric conditions or roadside obstacles prevent the installation of chevrons	• RPMs and Chevrons

SUGGESTED SPACING FOR DELINEATORS ON HORIZONTAL CURVES

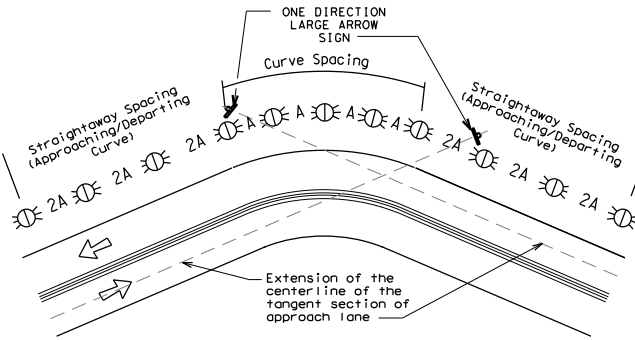

NOTE
ONE DIRECTION LARGE ARROW (W1-6) sign should be located at approximately and perpendicular to the extension of the centerline of the tangent section of approach lane.

SUGGESTED SPACING FOR CHEVRONS ON HORIZONTAL CURVES

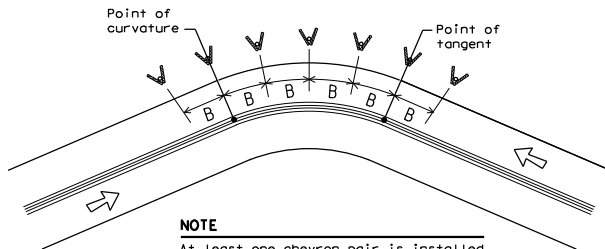

NOTE
At least one chevron pair is installed beyond the point of tangent in tangent section.

DELINEATOR AND CHEVRON SPACING

Degree of Curve	WHEN DEGREE OF CURVE OR RADIUS IS KNOWN			
	FEET			
	Radius of Curve	Spacing in Curve	Spacing in Straightway	Chevron Spacing in Curve
		A	2A	B
1	5730	225	450	—
2	2865	160	320	—
3	1910	130	260	200
4	1433	110	220	160
5	1146	100	200	160
6	955	90	180	160
7	819	85	170	160
8	716	75	150	160
9	637	75	150	120
10	573	70	140	120
11	521	65	130	120
12	478	60	120	120
13	441	60	120	120
14	409	55	110	80
15	382	55	110	80
16	358	55	110	80
19	302	50	100	80
23	249	40	80	80
29	198	35	70	40
38	151	30	60	40
57	101	20	40	40

Curve delineator approach and departure spacing should include 3 delineators spaced at 2A. This spacing should be used during design preparation or when the degree of curve is known.

DELINEATOR AND CHEVRON SPACING

Advisory Speed (MPH)	WHEN DEGREE OF CURVE OR RADIUS IS NOT KNOWN		
	Spacing in Curve	Spacing in Straightway	Chevron Spacing in Curve
	A	2xA	B
65	130	260	200
60	110	220	160
55	100	200	160
50	85	170	160
45	75	150	120
40	70	140	120
35	60	120	120
30	55	110	80
25	50	100	80
20	40	80	80
15	35	70	40

If the degree of curve is not known, delineator spacing may be determined based on the Advisory Speed of the curve. Use the delineator curve spacing for each Advisory Speed (MPH).

DELINEATOR AND OBJECT MARKER APPLICATION AND SPACING

CONDITION	REQUIRED TREATMENT	MINIMUM SPACING
Frwy./Exp. Tangent	RPMs	See PM-series and FPM-series standard sheets
Frwy./Exp. Curve	Single delineators on right side	See delineator spacing table
Frwy./Exp. Ramp	Single delineators on at least one side of ramp (should be on outside of curves) (see Detail 3 on D&OM(4))	100 feet on ramp tangents Use delineator spacing table for ramp curves ("straightway spacing" does not apply to ramp curves)
Acceleration/Deceleration Lane	Double delineators (see Detail 3 on D&OM(4))	100 feet (See Detail 3 on D & OM (4))
Truck Escape Ramp	Single red delineators on both sides	50 feet
Bridge Rail (steel or concrete) and Metal Beam Guard Fence	Bi-Directional Delineators when undivided with one lane each direction Single Delineators when multiple lanes each direction	Equal spacing (100' max) but not less than 3 delineators
Concrete Traffic Barrier (CTB) or Steel Traffic Barrier	Barrier reflectors matching the color of the edge line	Equal spacing 100' max
Cable Barrier	Reflectors matching the color of the edge line	Every 5th cable barrier post (up to 100' max)
Guard Rail Terminus/Impact Head	Divided highway - Object marker on approach end Undivided 2-lane highways - Object marker on approach and departure end	Requires reflective sheeting provided by manufacturer per D & OM (VIA) or a Type 3 Object Marker (OM-3) in front of the terminal end See D & OM (5) and D & OM (6)
Bridges with no Approach Rail	Type 3 Object Marker (OM-3) at end of rail and 3 single delineators approaching rail	See D & OM(5)
Reduced Width Approaches to Bridge Rail	Type 2 and Type 3 Object Markers (OM-3) and 3 single delineators approaching bridge	Requires reflective sheeting provided by manufacturer per D & OM (VIA) or a Type 3 Object Marker (OM-3) in front of the terminal end See D & OM (5)
Culverts without MGBF	Type 2 Object Markers	See Detail 2 on D & OM(4)
Crossovers	Double yellow delineators and RPMs	See Detail 1 on D & OM (4)
Pavement Narrowing (lane merge) on Freeways/Expressway	Single delineators adjacent to affected lane for full length of transition	100 feet

NOTES

- Unless indicated otherwise, the delineator or barrier reflector color shall conform to the color of the pavement edge line on the side of the road where the delineators or barrier reflectors are placed.
- Barrier reflectors may be used to replace required delineators.
- Single red delineators may be mounted on the back side of delineator posts for wrong way driver applications

LEGEND	
	Bi-directional Delineator
	Delineator
	Sign



Texas Department of Transportation
Traffic Safety Division Standard

DELINEATOR & OBJECT MARKER PLACEMENT DETAILS

D & OM(3) - 20

FILE: dam3-20.dgn	DN: TXDOT	CR: TXDOT	DN: TXDOT	CR: TXDOT
TXDOT August 2004	CONT SECT	JOB	HIGHWAY	
REVISIONS	641738	001	US 96, etc.	
3-15 8-15	DIST	COUNTY	SHEET NO.	
8-15 7-20	LFK	San Augustine	45	

DISCLAIMER: The use of this standard is governed by the "Texas Engineering Practice Act". No warranty of any kind is made by TxDOT for any purpose whatsoever. TxDOT assumes no responsibility for the conversion of units or the accuracy of the information contained herein. The user of this standard is responsible for its use.

DATE: 11/17/2022 2:21:57 PM
FILE: T:\LKFD\MAINT\Contract\30-RMC - Routine Maintenance\Contract\30-RMC - Routine Maintenance

DISCONTINUED
 The use of this standard is governed by the "Texas Engineering Practice Act". No warranty of any kind is made by TxDOT for any purpose whatsoever. TxDOT assumes no responsibility for the conversion of this standard to metric units.

DATE: 11/17/2022 2:28:19 PM
 FILE: T:\LK\KDM\Wgint_Contracts\0_RMC - Routine Maintenance Contracts\023 of 23\delinemat20.dgn

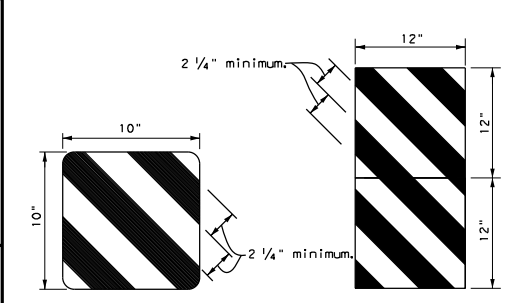
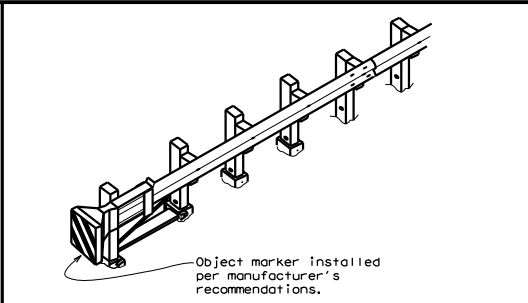
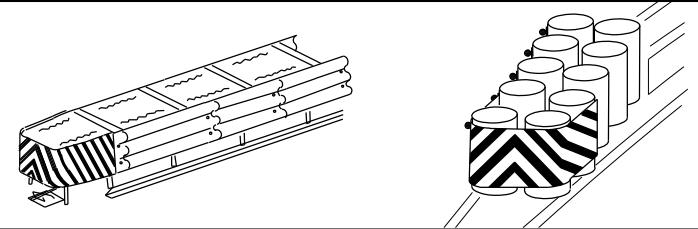
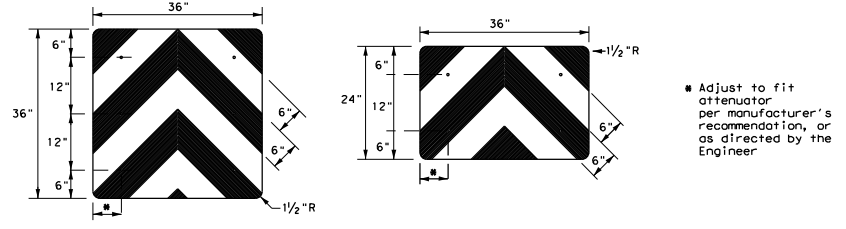
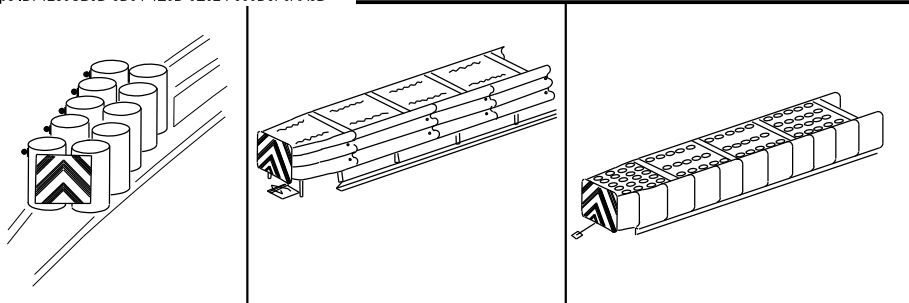

OBJECT MARKERS SMALLER THAN 3 FT²

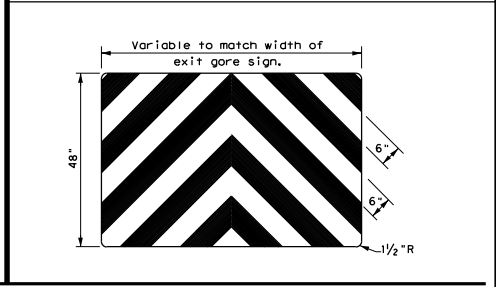
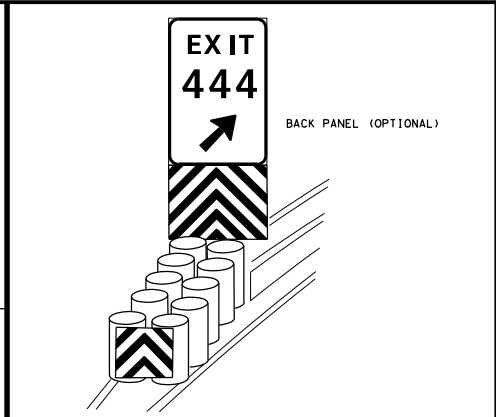

NOTES

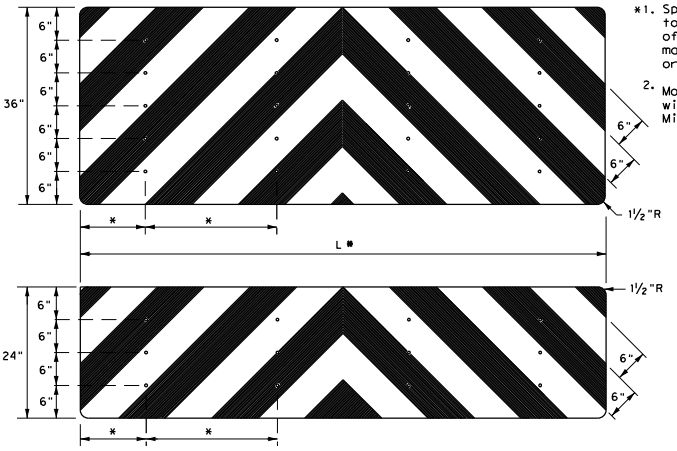

- *1. Spacing should be adjusted to attach through centerline of drum, per attenuator manufacturer's recommendation, or as directed by the Engineer.
- 2. Mounting should be flush with top of attenuator. Minimum size 96" x 24".

NOTES

1. Object Markers shall conform to the Texas MUTCD and meet the color and reflectivity requirement of Department Material Specification DMS 8300. Background shall be yellow reflective sheeting (Type B or C) and Chevron shall be black.
2. Object Markers may be fabricated from adhesive backed reflective sheeting applied directly to guardrail end treatment, or applied directly to an "end cap" as per the manufacturer's recommendation. Direct applied sheeting shall provide a smooth surface and have no wrinkles, air bubbles, cuts or tears. A radius at the corners is not required for direct applied sheeting.
3. Object Marker size may be reduced to fit smaller devices. Width of alternating black and yellow stripes are typically 6". Object Markers smaller than 3ft may have reduced width stripes of a minimum of 2 1/4".
4. Pop rivets, screws, or nuts and bolts may be used to attach object markers and reflectors. Holes, slots or other openings may be cut or drilled through object markers to allow cable or other attachments.
5. Object Marker at nose of attenuator is subsidiary to the attenuator.
6. See D & OM (1-4) for required barrier reflectors.

		Traffic Safety Division Standard	
DELINEATOR & OBJECT MARKER FOR VEHICLE IMPACT ATTENUATORS D & OM (VIA) - 20			
FILE: ddmvia20.dgn	DN: TXDOT	CR: TXDOT	OR: TXDOT
TXDOT December 1989	CONT SECT	JOB	HIGHWAY
4-92 8-04 REVISIONS	6417 38	001	US 96, etc.
8-95 3-15	DIST	COUNTY	SHEET NO.
4-98 7-20	LFK	San Augustine	46
206			

DISCLAIMER:
The use of this standard is governed by the "Texas Engineering Practices Act". No warranty of any kind is made by TxDOT for any purpose whatsoever. TxDOT assumes no responsibility for the construction of any structure to which this standard is not specifically referred to in drawings resulting from its use.

DATE: 11/17/2022 2:30:29 PM
FILE: T:\LK\KDM\mnt\contracts\0-RMC - Routine Maintenance Contracts\1723 P\ons\6417-38-001_Son Augustine MBGF\DDN\STANDARD\BRIDGE\T631-CM_CGN

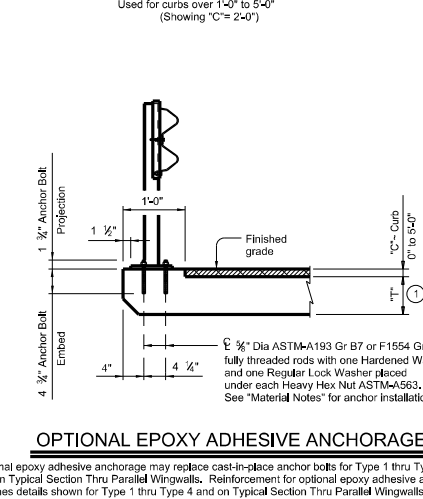
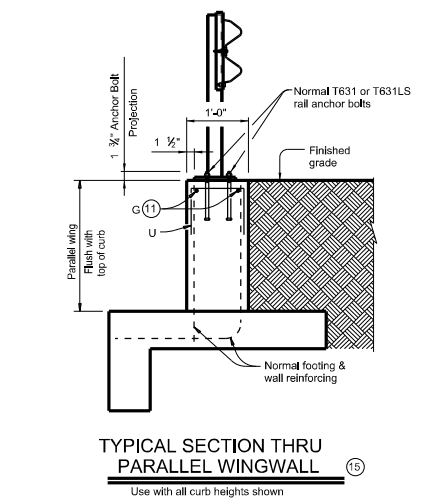
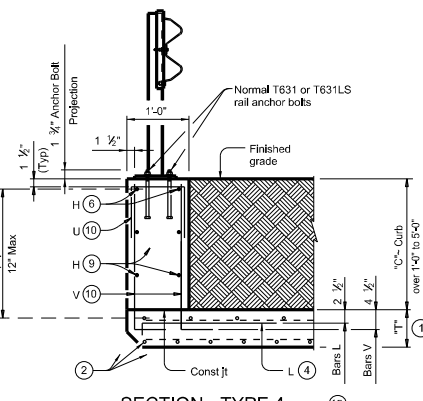
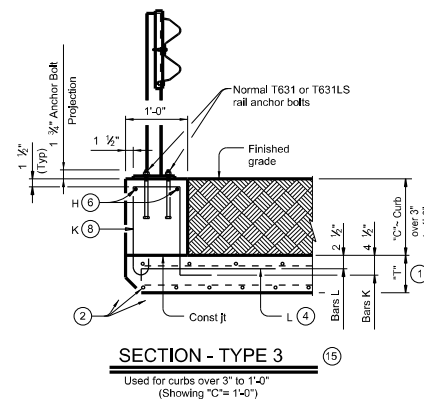
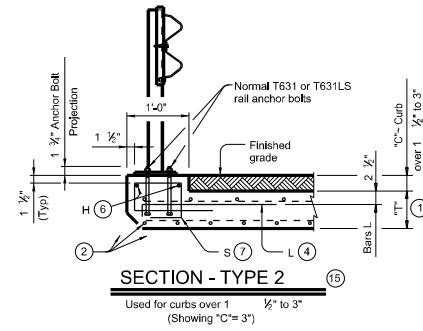
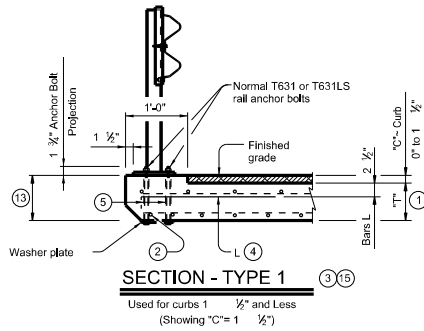

- ① "T" is equal to the culvert top slab thickness. For precast boxes with slabs less than 7" thick, see SCP-MD standard for additional details.
- ② Adjust normal culvert slab bars as necessary to clear obstructions.
- ③ Omit normal culvert curb bars K and H.
- ④ Place bars L as shown. Tilt hook as necessary to maintain cover.
- ⑤ 4 formed holes for anchor bolts at each rail post. See rail standard for information not shown.
- ⑥ Place normal culvert curb bars H (#4) as shown. Adjust as necessary to clear obstructions.
- ⑦ Omit normal culvert curb bars K. Place bars S as shown. Tilt bars S as necessary to maintain cover.
- ⑧ Place normal culvert curb bars K spaced at 12" Max as shown. Tilt bars K as necessary to maintain cover. Refer to box culvert details sheets for bars K details.
- ⑨ Additional bars H (#4) as required to maintain 12" Max spa.
- ⑩ At TYPE 4 mountings, replace normal culvert curb bars K with one bar U and two bars V as shown spaced at 12" Max. Adjust length of bars V as necessary to maintain clear cover.
- ⑪ Adjust parallel wing bars G to positions shown.
- ⑫ Optional bars L are to be used only for precast box culverts with 3'-0" closure pour.
- ⑬ If "T" plus "C" is greater than 8", provide reinforcement per TYPE 1 mounting and anchor bolts per TYPE 2 mounting.
- ⑭ Quantities shown are for Contractor's information only. Quantities are per linear foot of curb length. The values for each section type in table can be interpolated for intermediate values of curb height, "C". Quantity includes bars K (when applicable).
- ⑮ An epoxy anchorage system shown on this sheet may be substituted for the normal anchor bolts shown on the T631 or T631LS rail standard. See Material Notes for optional epoxy anchorage system.

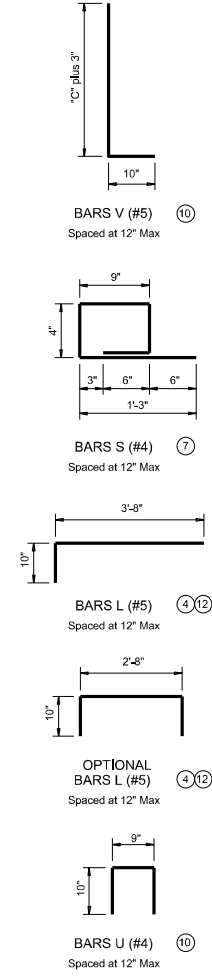

TABLE OF ESTIMATED CURB QUANTITIES ⁽¹⁴⁾				
Curb Height "C"	Section Type	Conc (CY/LF)	Reinf Steel (Lb/LF)	
1 1/2"	1	0.005	4.7	
3"	2	0.009	8.4	
6"	3	0.019	8.9	
1'-0"	3	0.037	8.9	
1'-6"	4	0.056	14.3	
2'-0"	4	0.074	15.4	
2'-6"	4	0.093	17.7	
3'-0"	4	0.111	19.8	
3'-6"	4	0.130	21.2	
4'-0"	4	0.148	22.2	
4'-6"	4	0.167	24.6	
5'-0"	4	0.185	25.6	

CONSTRUCTION NOTES:
For vehicle safety, finished grade must be flush with top of curb.
Adjust reinforcing as necessary to provide 1 1/2" cover.

MATERIAL NOTES:
Provide concrete for curb of the same Class and strength as the box culvert top slab.
Galvanize all steel components except reinforcing steel unless noted otherwise.
Provide Grade 60 reinforcing.
Optional epoxy adhesive anchor bolts must be ASTM-A193 Gr B7 or F1554 Gr 105 fully threaded rods with one Hardened Washer and one Regular Lock Washer placed under each Heavy Hex Nut ASTM-A563. Embed threaded rods 4 3/8" Min into slab and/or abutment wingwall using a Type III, Class C, D, E or F epoxy adhesive anchorage system capable of obtaining an ultimate load, per threaded rod, of 8 kips in tension. Submit evidence of the proposed epoxy adhesive anchorage system's ability to develop this load to the Engineer for approval prior to use. Anchor installation, including hole size, drilling, and clean-out, must be in accordance with the Manufacturer's instructions.

GENERAL NOTES:
Designed in accordance with AASHTO LRFD Bridge Design Specifications.
See T631 or T631LS rail standard for approved speed restrictions, notes and details not shown.
The curb is considered as part of the box culvert for payment.
These details are for use with curbs that are 5'-0" tall and less only. Curb heights that are less than or greater than those shown will require special design.

Cover dimensions are clear dimensions, unless noted otherwise.
Reinforcing bar dimensions shown are out-to-out of bar.

The use of the T631LS rail is restricted to speeds of 45 mph or less.

Texas Department of Transportation Bridge Division Standard

BOX CULVERT MOUNTING DETAILS FOR TYPE T631 & T631LS RAILS (CURBS 5' TALL AND LESS ONLY) T631-CM

FILE: feldm0.cgn	DR: TxDOT	CR: TxDOT	DR: JTR	DR: AES
©TxDOT March 2016	CDMT	BRST	JOB	HS-WAY
6417 38	001	US 96, etc.		
BRST	COUNTY	SHEET NO.		
LFK	San Augustine	47		

DISCLAIMER:
The use of this standard is governed by the "Texas Engineering Practice Act". No warranty of any kind is made by the Texas Department of Transportation for the construction of this standard to other formats or for increased loads or damage resulting from its use.

DATE: 11/17/2022 2:46:08 PM
FILE: T:\L\FKDM\Wgint\Contracts\0-RMC - Routine Maintenance Contracts\FY23 Plans\6417-38-001_Son Augustine MBGF DOWN STANDARD-BRIDGES\T631.dgn

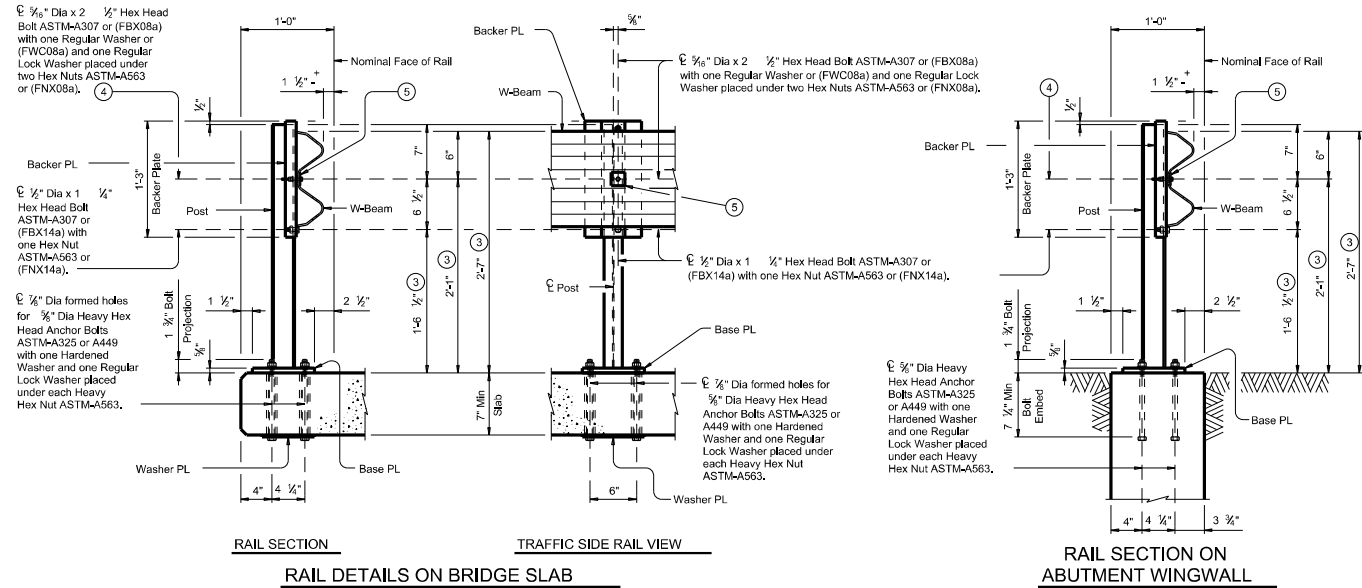
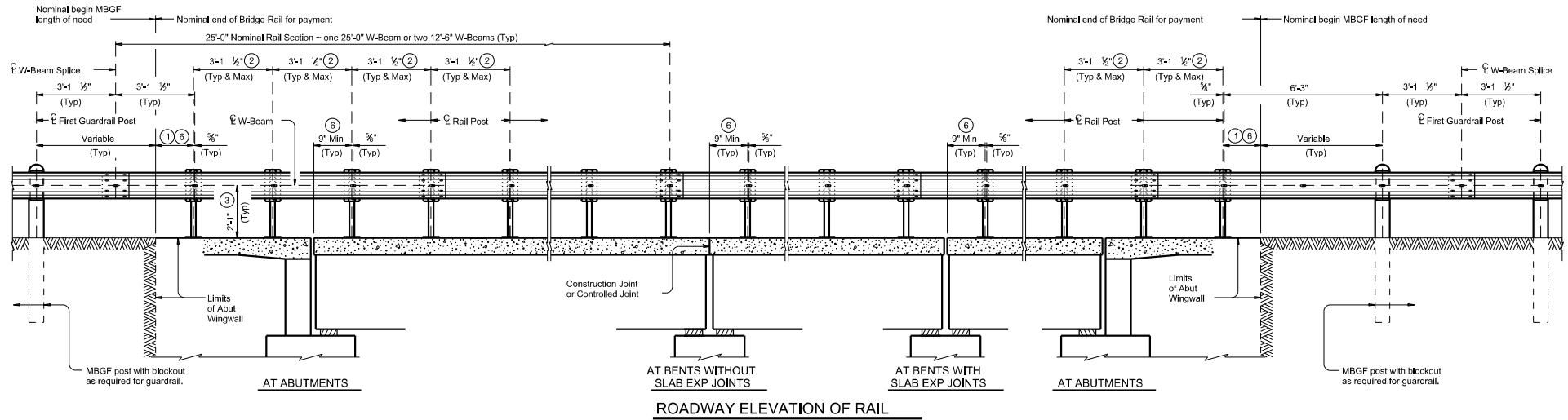

- ① 9" Min, 5-9" Max
- ② Maintain 3-1 1/2" Rail Post spacing wherever possible for use with nominal 25'-0" or 12'-6" W-Beam sections. Symmetry of post spacing on both sides and along the structure is not necessary.
- ③ Increase 2" for structures with overlay.
- ④ Tighten the first hex nut by hand until the top and bottom edges of the W-beam engage the Backer Plate (Backer Plate should be snug against the post). Then tighten hex nut one revolution with wrench and secure with the second hex nut.
- ⑤ PL 1/2" x 1 3/4" x 1 1/2" with 3/8" Dia Hole centered in PL. ASTM-A36. Square Guardrail Washer (FWR01).
- ⑥ The post nearest to a slab joint or end of structure may be shifted up to 9" in order to satisfy the minimum offset dimension. Drill a new 1/2" Dia hole on the centerline of W-beam for shifted post. Paint hole with two coats of zinc-rich paint conforming to the Item "Galvanizing". All other posts must remain on the typical spacing.

SHEET 1 OF 2

		<i>Bridge Division Standard</i>	
TRAFFIC RAIL			
TYPE T631			
FILE: t631038.dgn	DATE: TxDOT 07/2014	CHK: AES	DES: JTR
6417	38	001	US 96, etc.
LFK	Son Augustine		48

DISCLAIMER:
The use of this standard is governed by the "Texas Engineering Practice Act". No warranty of any kind is made by the Texas Department of Transportation for the conformance of this standard to other formats or for increased loads or damages resulting from its use.

DATE: 11/17/2022 2:46:08 PM
FILE: T:\LK\DOM\Maint Contracts\0.RMC - Routine Maintenance Contracts\123 Plots\6417-38-001_Son Augustine MBGF IDONN STANDARD-BRIDGET.T631.dgn

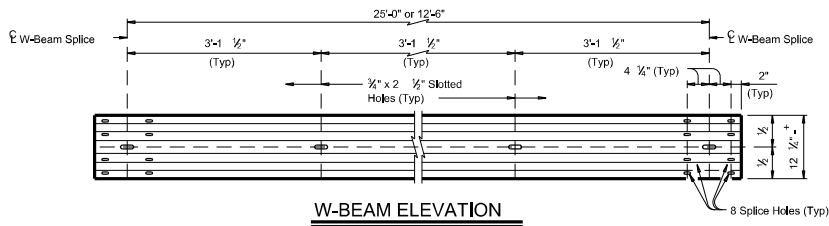

W-BEAM ELEVATION

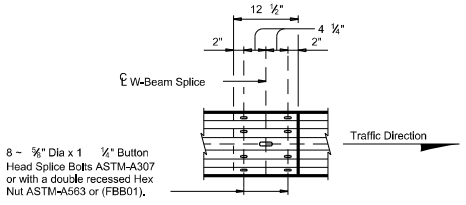

W-BEAM SPLICE ELEVATION

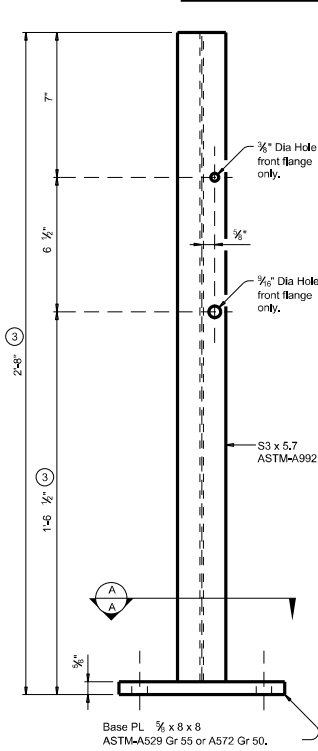

POST ELEVATION

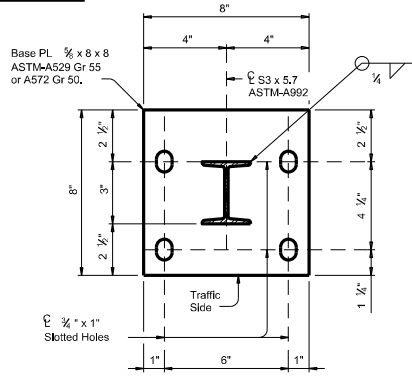

SECTION A-A

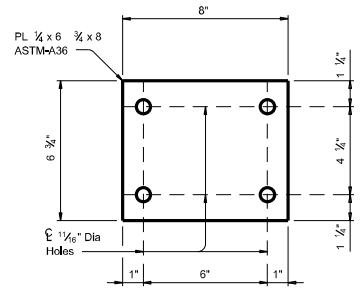

WASHER PLATE DETAIL

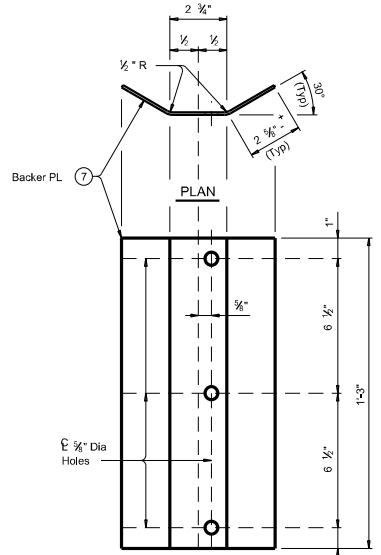

BACKER PLATE

- ③ Increase 2" for structures with overlay.
- ⑦ Backer PL 1/8" x 8" x 1'-3" ASTM-A1011 CS or SS Gr 33, or A1008 CS or SS Gr 33 (11 Gauge acceptable).

MBGF AND END TREATMENT NOTES:
This traffic railing must be anchored by metal beam guard fence (MBGF) and guard fence end treatments. Determine MBGF length of need in accordance with the Roadway Design Manual, unless otherwise specified. The minimum MBGF length of need required for anchoring the railing is 25' of MBGF plus the appropriate end treatment.

CONSTRUCTION NOTES:
Face of rail post must be plumb unless otherwise approved by the Engineer. Post must be perpendicular to adjacent roadway grade. Use epoxy mortar under post base plates if gaps larger than 1/8" exist.
Fully anchored guardrail must be attached to each end of rail. A metal beam guard fence transition is not used with this rail.
It is recommended to show a Rail Layout with rail posts and W-beam splices. Fabricator must submit erection drawings to the Engineer for approval.
Round or chamfer exposed edges of rail post and backer plate to approximately 1/8" by grinding.
Shop drawings are not required for this rail.

MATERIAL NOTES:
Galvanize all steel components.
Anchor bolts for base plate must be 3/4" Dia ASTM-A325 or A449 bolts with one hardened washer and one regular lock washer placed under each heavy hex nut. Nuts must conform to A563 requirements.
W-beam must meet the requirements of Item 540, "Metal Beam Guard Fence" except as modified in the plans. The Contractor may furnish rail elements of 25'-0", or 12'-6" (Nominal) lengths. W-Beam must have slotted holes at 3'-1 1/2".
Some part numbers from the "Task Force 13" Guide to Standardized Highway Barrier Hardware have been furnished for quick reference.

GENERAL NOTES:
This railing has been successfully evaluated by full-scale crash test to meet MASH TL-3 criteria. This railing can be used for speeds of 50 mph and greater. This rail is designed to deflect approximately 4" to 4'-0" as it contains and redirects the errant vehicle. This rail may not be installed on top of or behind curbs that project above finished grade, on bridges with expansion joints providing more than 5" movement, on retaining walls, or on grade separations and interchanges.
Repairs to impact-damaged post and base plate unit are not permitted. Replace all impact-damaged posts with a new post and base plate unit.
Average weight of railing with no overlay: 19 plf total.

TRAFFIC RAIL			
TYPE T631			
FILE: t631038.dgn	DATE: 12/07/2014	CHK: AES	DATE: 12/07/2014
DESIGNER: RVP/RP/AS	CONTRACT: 641738	SHEET: 001	PROJECT: US 96, etc.
DATE: 12/07/2014	COUNTY: LFK	CITY: San Augustine	SHEET NO: 49

DISCLAIMER: The use of this standard is governed by the "Texas Engineering Practice Act". No warranty of any kind is made by the Texas Department of Transportation for the conversion of this standard to other formats or for incorrect results or damages resulting from its use.

DATE: 11/17/2022 2:46:41 PM
 FILE: T:\LK\KDM\mnt\contracts\0_RMC - Routine Maintenance Contracts\FY23 Plans\6417-38-001_Son Augustine MBGF\DDN STANDARD\BRIDGE\T631L.dgn

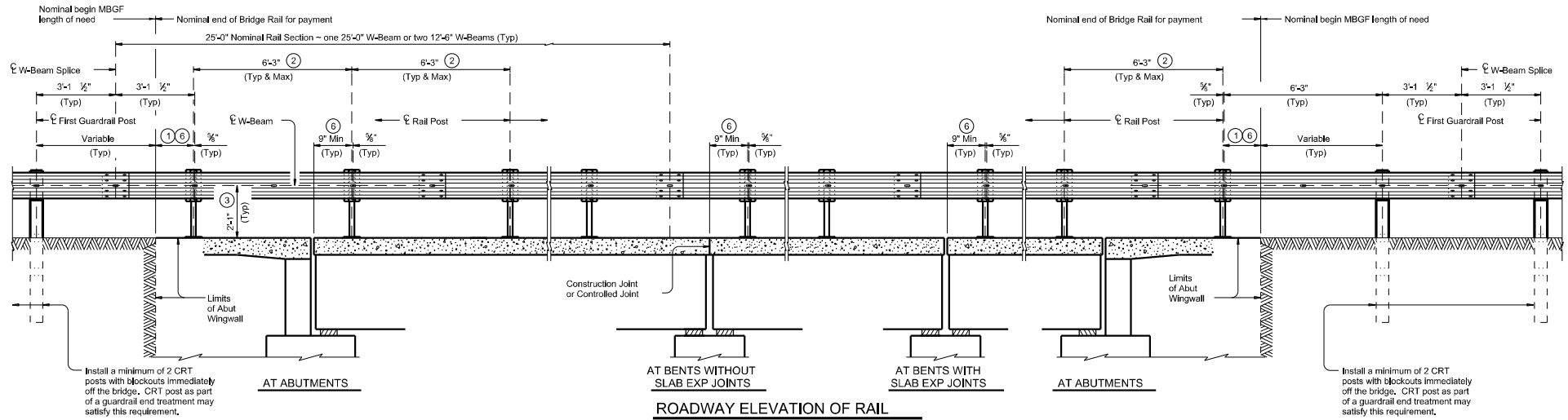

- ① 9" Min, 5'-9" Max
- ② Maintain 6'-3" Rail Post spacing wherever possible for use with nominal 25'-0" or 12'-6" W-Beam sections. Symmetry of post spacing on both sides and along the structure is not necessary.
- ③ Increase 2" for structures with overlap.
- ④ Tighten the first hex nut by hand until the top and bottom edges of the W-Beam engage the Backer Plate (Backer Plate should be snug against the post). Then tighten hex nut one revolution with wrench and secure with the second hex nut.
- ⑤ PL 1/2" x 1 1/4" x 1 3/4" with 3/8" Dia Hole centered in PL, ASTM-A36, Square Guardrail Washer (FWR01).
- ⑥ The post nearest to a slab joint or end of structure may be shifted up to 9" in order to satisfy the minimum offset dimension. Drill a new 3/4" Dia hole on the centerline of W-Beam for shifted post. Paint hole with two coats of zinc-rich paint conforming to the item "Galvanizing". All other posts must remain on the typical spacing.

The use of this railing is restricted to speeds of 45 mph or less.

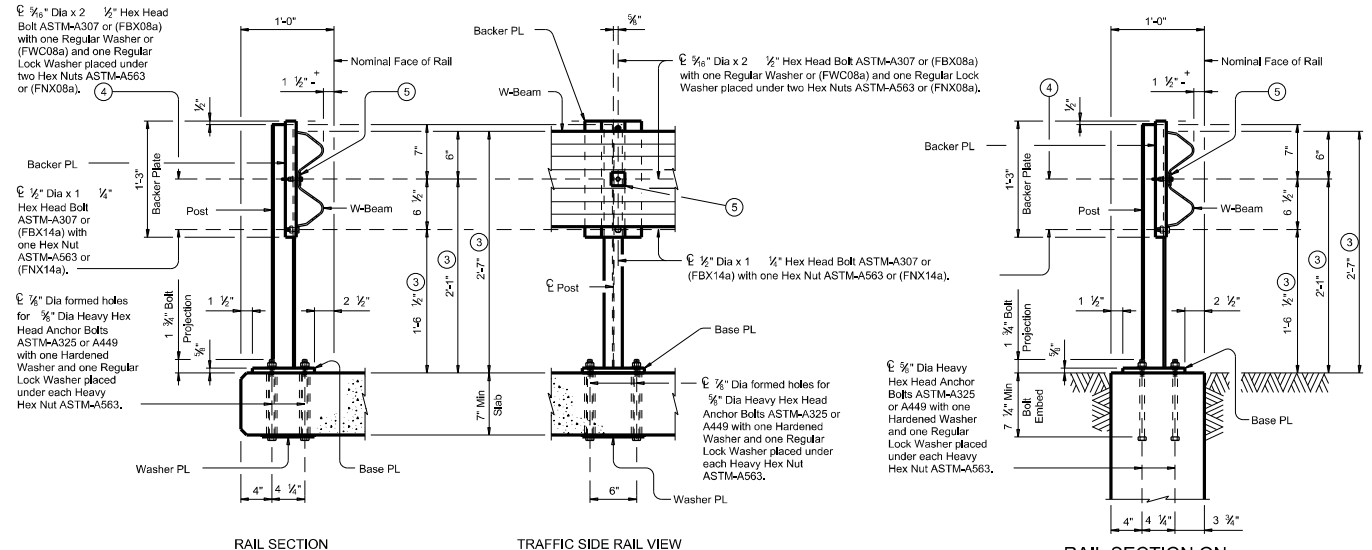

RAIL SECTION
 RAIL DETAILS ON BRIDGE SLAB

RAIL SECTION ON
 ABUTMENT WINGWALL

SHEET 1 OF 2

		Bridge Division Standard	
<h2>TRAFFIC RAIL</h2> <h3>TYPE T631LS</h3>			
FILE: t631l.dgn DATE: July 2014 REV: RPK/AVS	DWT: 6417 BRST: 38 COUNTY: LFK	CDR: AES JOB: 001 COUNTY: Son Augustine	DWT: AES JOB: HS-WAY US 96, etc. SHEET NO.: 50

DISCLAIMER: The use of this standard is governed by the "Texas Engineering Practice Act". No warranty of any kind is made by the Texas Department of Transportation for the accuracy, reliability or the compliance of this standard to other forms or for increased results or damage resulting from its use.

DATE: 11/17/2022 2:46:42 PM
 FILE: T:\LK\KDM\Waint Contracts\0-RMC - Routine Maintenance Contracts\FY23 Plans\6417-38-001_Son Augustine\MBGF\DDN\STANDARD\BRIDGE\T631L.dgn

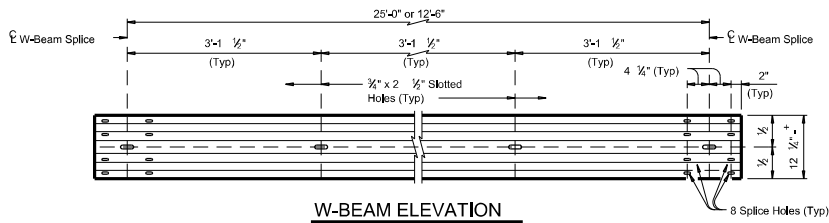

W-BEAM ELEVATION

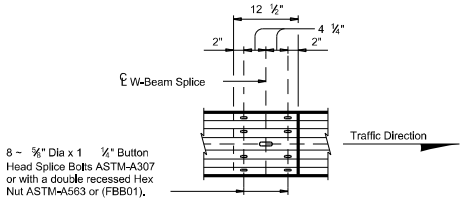

W-BEAM SPlice ELEVATION

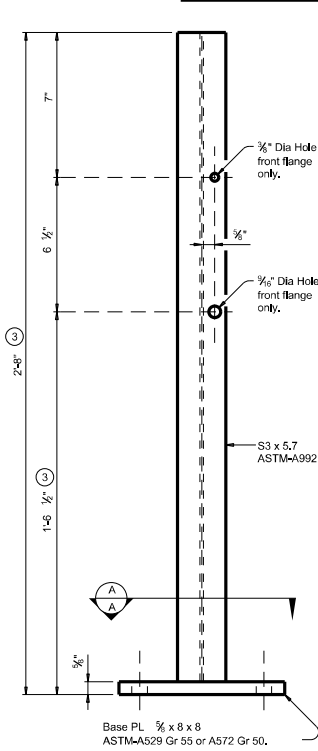

POST ELEVATION

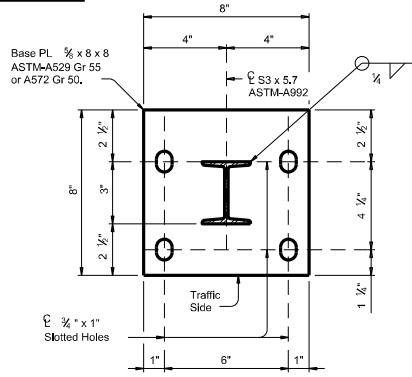

SECTION A-A

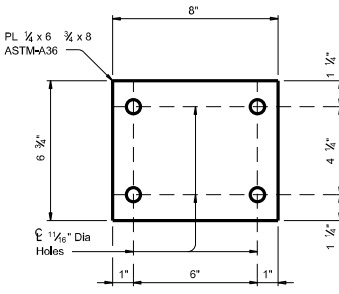

WASHER PLATE DETAIL

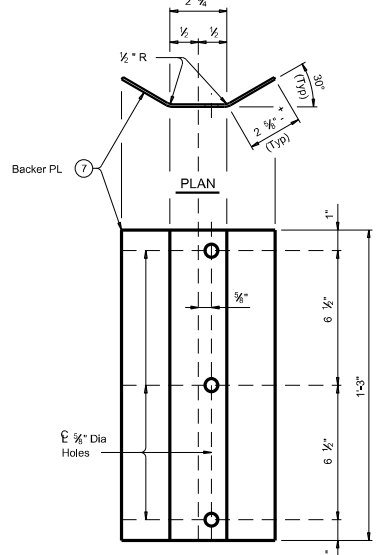

ELEVATION

BACKER PLATE

- ③ Increase 2" for structures with overlay.
- ⑦ Backer PL 1/8" x 8 x 1'-3" ASTM-A1011 CS or SS Gr 33, or A1008 CS or SS Gr 33 (11 Gauge acceptable).

MBGF AND END TREATMENT NOTES:
 This traffic railing must be anchored by metal beam guard fence (MBGF) and/or guard fence end treatments. Determine MBGF length of need in accordance with the Roadway Design Manual, unless otherwise specified. The minimum MBGF length of need required for anchoring the railing is: SGT or DAT plus 12.5' of MBGF, as applicable. Provide CRT posts as shown in "Roadway Elevation of Rail."

CONSTRUCTION NOTES:
 Face of rail post must be plumb unless otherwise approved by the Engineer. Post must be perpendicular to adjacent roadway grade. Use epoxy mortar under post base plates if gaps larger than 1/8" exist.
 Fully anchored guardrail must be attached to each end of rail. A metal beam guard fence transition is not used with this rail.
 It is recommended to show a Rail Layout with rail posts and W-beam splices. Fabricator must submit erection drawings to the Engineer for approval.
 Round or chamfer exposed edges of rail post and backer plate to approximately 1/8" by grinding.
 Shop drawings are not required for this rail.

MATERIAL NOTES:
 Galvanize all steel components.
 Anchor bolts for base plate must be 3/4" Dia ASTM-A325 or A449 bolts with one hardened washer and one regular lock washer placed under each heavy hex nut. Nuts must conform to A563 requirements.
 W-beam must meet the requirements of Item 540, "Metal Beam Guard Fence" except as modified in the plans. The Contractor may furnish rail elements of 25'-0", or 12'-6" (Nominal) lengths. W-Beam must have slotted holes at 3'-1 1/2".
 Some part numbers from the "Task Force 13" Guide to Standardized Highway Barrier Hardware have been furnished for quick reference.

GENERAL NOTES:
 This railing has been successfully evaluated by full-scale crash test to meet MASH TL-2 criteria. This railing can be used for speeds of 45 mph and less. This rail is designed to deflect approximately 2' to 2'-6" as it contains and redirects the errant vehicle. This rail may not be installed on top of or behind curbs that project above finished grade, on bridges with expansion joints providing more than 5" movement, on retaining walls, or on grade separations and interchanges.
 Repairs to impact-damaged post and base plate unit are not permitted. Replace all impact-damaged posts with a new post and base plate unit.
 Average weight of railing with no overlay: 13 plf total.

SHEET 2 OF 2		Bridge Division Standard	
TRAFFIC RAIL			
TYPE T631LS			
FILE: t631037.dgn	DATE: 11/17/2022	DATE: 11/17/2022	DATE: 11/17/2022
DESIGNER: JES	CHECKER: JES	DATE: 11/17/2022	DATE: 11/17/2022
PROJECT: 6417 38	JOB: 001	COUNTY: US	US 96, etc.
DESIGNER: LFK	CHECKER: JES	COUNTY: San Augustine	SHEET NO: 51

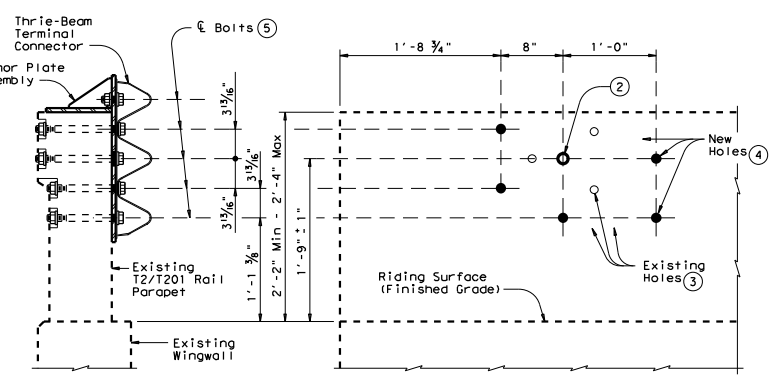
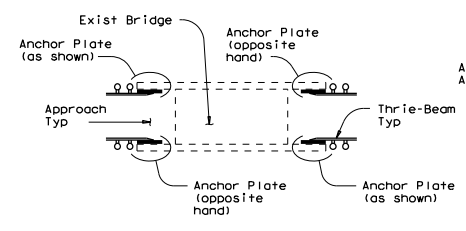
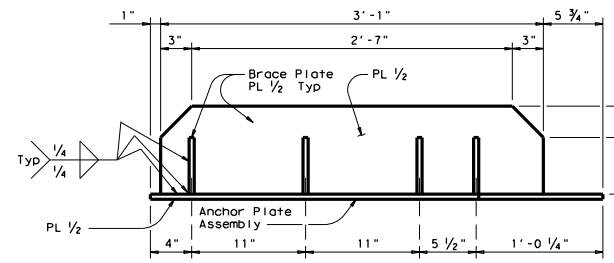

THRIE-BEAM TERMINAL CONNECTION DETAILS

CONSTRUCTION NOTES:
On T2 rail remove any MBGF (W-beam) and attachment hardware, from the face of rail if present, prior to installation of new MBGF Transition. Dispose of these materials as directed by the Engineer. Plugging of newly exposed bolt holes is not necessary unless directed otherwise. This work is considered subsidiary to the pertinent bid items.
Attach the MBGF Transition to the existing parapet using the Anchor Plate assembly and the Thrie-Beam Terminal Connector. Splice the Thrie-Beam Terminal Connection and Thrie-Beam with the normal T2 connection bolts. Refer to Metal Beam Guard Fence Transition and Metal Beam Guard Fence detail sheets for additional details and information not shown herein.

MATERIAL NOTES:
Fabricate Anchor Plate assembly with steel conforming to either ASTM A36 or A572 Gr 50. Anchor Plate assembly must be free of burrs, sharp edges and weld splatter. Grind edges and corners to a 1/16" fillet or radius. Hot-dip galvanize Anchor Plate assembly in accordance with Item 445, "galvanizing". Anchor bolts, nuts, and washers must conform to Item 449, "Anchor Bolts".

GENERAL NOTES:
These details are for retrofitting existing rails only, not new construction, with a Thrie-Beam Terminal Connection. Shop drawings are not required for this installation. Materials, fabrication and installation of this assembly are to be included in the price bid for "Metal Beam Guard Fence Transition".
Estimated weight of a single Anchor Plate assembly, including bolts, nuts, and washers, but not including the Thrie-Beam Terminal Connector = 190 Lbs.

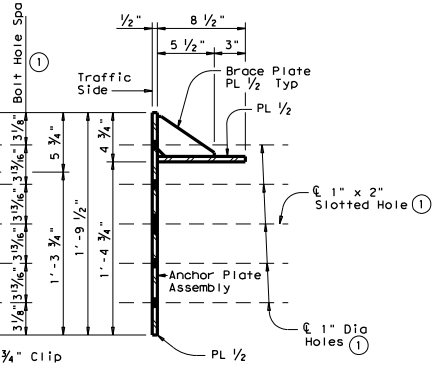
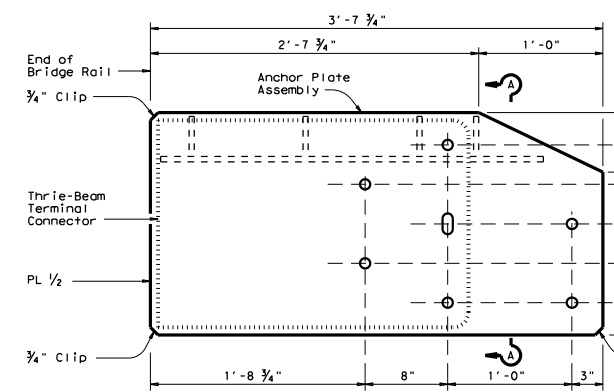
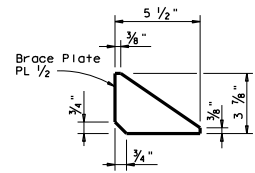

ANCHOR PLATE DETAILS

Anchor Plate shown is detailed for one end of one side of rail only. For other side, Anchor Plate must be built opposite hand.

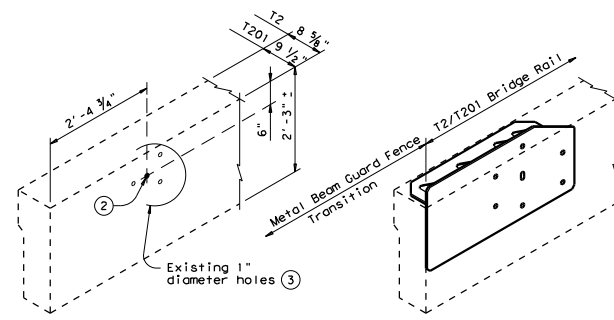

INSTALLATION DETAILS

- The Contractor must verify that locations of bolt holes match those in the Thrie-Beam Terminal Connector to be installed in that location, prior to fabrication of Anchor Plate assembly and prior to coring bolt holes in the existing T2/T201 parapet.
- If the existing holes are aligned as expected, use the indicated existing 1" diameter hole in the installation of the Anchor Plate assembly and the Thrie-Beam Terminal Connector.
- If the existing holes are not aligned as expected, holes that cannot be utilized in the installation and are within 3" of a new bolt hole must be filled with epoxy grout prior to coring new holes.
- Drill new 1" diameter holes, each with a 2 1/2" diameter x 1" deep recess, through existing railing parapet. Note that recesses are only required when pedestrian sidewalks are adjacent to back of rail unless directed otherwise by the Engineer. Holes should be perpendicular to the roadside face of the parapet. Drill holes and recesses with coring type equipment. Percussion drilling is not allowed. Patch spalls, when directed by the Engineer, in accordance with Item 429, "Concrete Structure Repair", at the Contractor's expense.
- 7 - 3/4" diameter A325 Hex Head Anchor Bolts each with 2 - 1 3/4" O.D. washers. Place washer under each head and nut. Provide bolts of sufficient length to extend a minimum of 1/2" beyond nut. Cut excess bolt length and paint cut surface with zinc-rich paint if directed by the Engineer.



DocuSigned by:
Jeremy King, P.E.
5135292EE418A44
12/6/2022

Texas Department of Transportation
Bridge Division

**T2/T201 TRANSITION
RETROFIT GUIDE**

T2/T201TR (MOD)

FILE: f1st025.dgn	DN: TxDOT	CK: TxDOT	DN: JTR	CK: JMH
© TxDOT April 2009	DISTRICT	PROJECT NO.	SHEET	
REVISIONS	LFK	RMC 6417-38-001	52	
COUNTY	CONTROL	SECT	JOB	HIGHWAY
San Augustine 6417 38 001 US 96, etc				

LEVELS DISPLAYED: 12/11/15 12:33:36
PATH: \\...
171.81.96.242:2127...
33.4.53.63:71.81.96.242:2127...
69.52.19.25:71.81.96.242:2127...

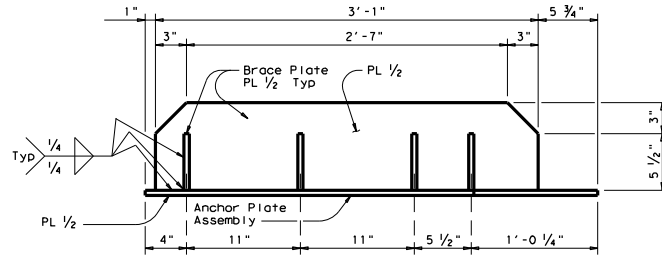

PLAN

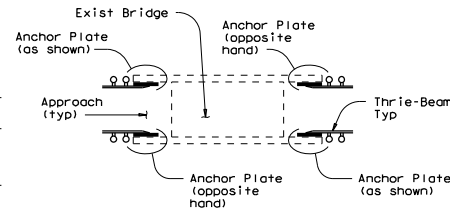

LOCATION DETAILS

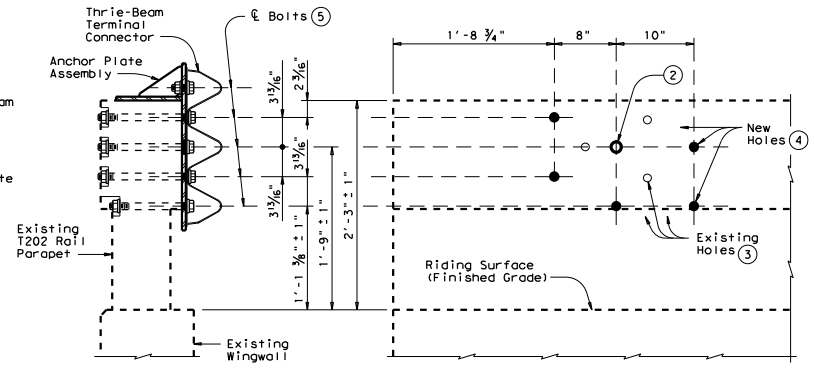

SECTION
Showing completed installation

ROADSIDE ELEVATION
Anchor Plate assembly and Thrie-Beam Terminal Connector not shown for clarity

DETAILS OF BOLTS AND HOLES ①

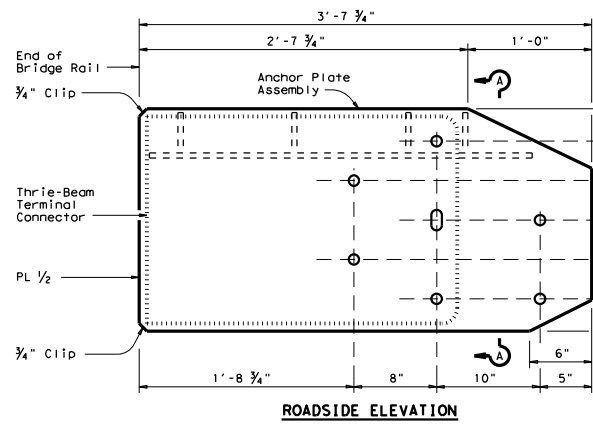

ROADSIDE ELEVATION

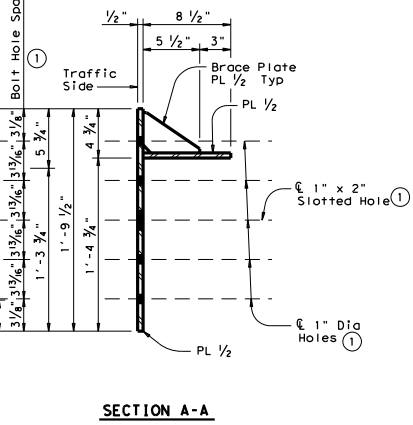

SECTION A-A

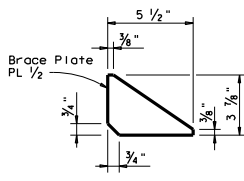

BRACE PLATE DETAILS

ANCHOR PLATE DETAILS

Anchor Plate shown is detailed for one end of one side of rail only. For other side, Anchor Plate must be built opposite hand.

CONSTRUCTION NOTES:
Attach the MBGF Transition to the existing parapet using the Anchor Plate assembly and the Thrie-Beam Terminal Connector. Splice the Thrie-Beam Terminal Connection to the Thrie-Beam with the normal 12 connection bolts. Refer to Metal Beam Guard Fence Transition and Metal Beam Guard Fence detail sheets for additional details and information not shown herein.

MATERIAL NOTES:
Fabricate Anchor Plate assembly with steel conforming to either ASTM A36 or A572 Gr 50. Anchor Plate assembly must be free of burrs, sharp edges and weld splatter. Grind edges and corners to a 1/16" flat or radius. Hot-dip galvanize Anchor Plate assembly in accordance with Item 445, "Galvanizing". Anchor bolts, nuts, and washers must conform to Item 449, "Anchor Bolts".

GENERAL NOTES:
These details are for retrofitting existing rails only, not new construction, with a Thrie-Beam Terminal Connection. Shop drawings are not required for this installation. Materials, fabrication and installation of this assembly are to be included in the price bid for "Metal Beam Guard Fence Transition". Estimated weight of a single Anchor Plate assembly, including bolts, nuts, and washers, but not including the Thrie-Beam Terminal Connector = 190 Lbs.

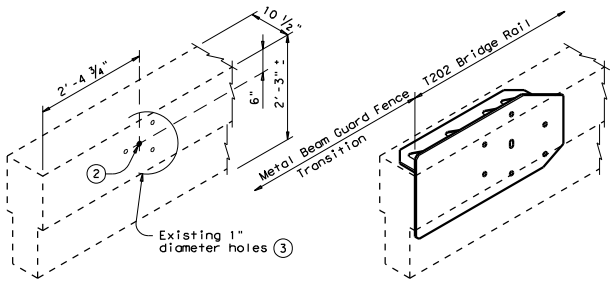

EXISTING PARAPET
Shown after removal of existing MBGF Transition connector and prior to coring new bolt holes

ANCHOR PLATE PLACEMENT

INSTALLATION DETAILS

- ① The Contractor must verify that locations of bolt holes match those in the Thrie-Beam Terminal Connector to be installed in that location prior to fabrication of the Anchor Plate assembly and prior to coring bolt holes in the existing T202 parapet.
- ② If the existing holes are aligned as expected, use the indicated existing 1" diameter hole in the installation of the Anchor Plate assembly and the Thrie-Beam Terminal Connector.
- ③ If the existing holes are not aligned as expected, holes that cannot be utilized in the installation and are within 3" of a new bolt hole must be filled with epoxy grout prior to coring new holes.
- ④ Drill new 1" diameter holes, each with a 2 1/2" diameter x 1" deep recess, through existing railing parapet. Recesses are only required when pedestrian sidewalks are adjacent to back of rail unless directed otherwise by the Engineer. Holes should be perpendicular to the roadside face of the parapet. Drill holes and recesses with coring type equipment. Percussion drilling is not allowed. Patch spalls, when directed by the Engineer, in accordance with Item 429, "Concrete Structure Repair", at the contractor's expense.
- ⑤ 7 - 3/4" diameter A325 Hex Head Anchor Bolts each with 2 - 1 3/4" O.D. washers. Place washer under each head and nut. Provide bolts of sufficient length to extend a minimum of 1/2" beyond nut. Cut excess bolt length and paint cut surface with zinc-rich paint if directed by the Engineer.



DocuSigned by:
Jeremy King, P.E.
3/27/2022

Texas Department of Transportation
Bridge Division

T202 TRANSITION RETROFIT GUIDE

T202TR (MOD)

FILES: r1st0226.dgn	DWG: TxDOT	CX: TxDOT	DWG: JTR	CX: JMR
© TxDOT April 2009	DISTRICT: LFK	PROJECT NO.: RMC 6417-38-001	SHEET 53	
REVISIONS		COUNTY: San Augustine	CONTROL: 6417 38	JOB: 00IUS 96, etc

LEVELS DISPLAYED: 0.00, 0.25, 0.50, 1.00, 1.50, 2.00, 2.50, 3.00, 3.50, 4.00, 4.50, 5.00, 5.50, 6.00, 6.50, 7.00, 7.50, 8.00, 8.50, 9.00, 9.50, 10.00

DISCUSS: THIS STANDARD IS GOVERNED BY THE "TEXAS ENGINEERING PRACTICE ACT". NO WARRANTY OF ANY KIND IS MADE BY TxDOT FOR ANY PURPOSE WHATSOEVER. TxDOT ASSUMES NO RESPONSIBILITY FOR THE CONVERSION OF THIS STANDARD TO OTHER FORMATS OR FOR INCORRECT RESULTS OR DAMAGES RESULTING FROM ITS USE.
 DATE: 11/17/2022 2:55:46 PM
 FILE: T:\LFDKDMaint Contracts\0-RMC - Routine Maintenance Contracts\123 Plans\6417-38-001 San Augustine MBEF\DDN\STANDARD\BRIDGE\BED(28)-19.dgn

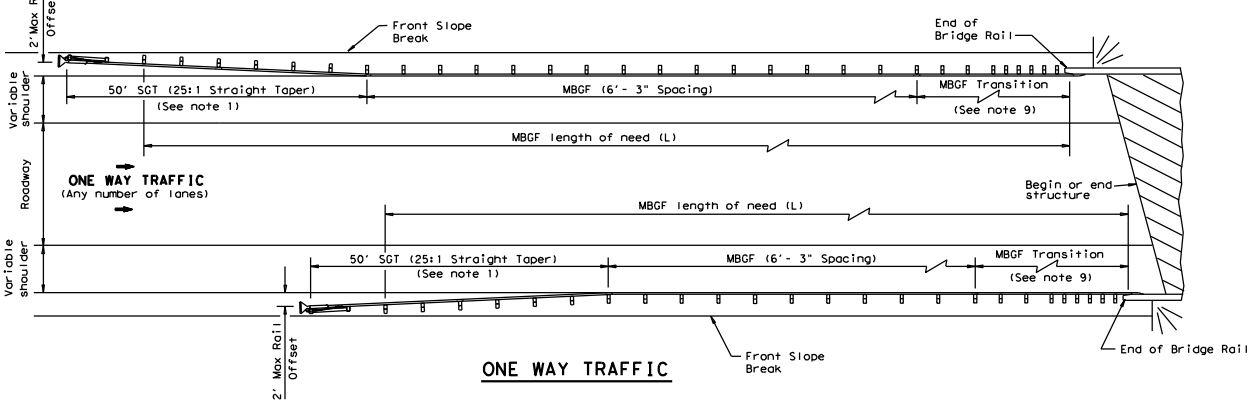
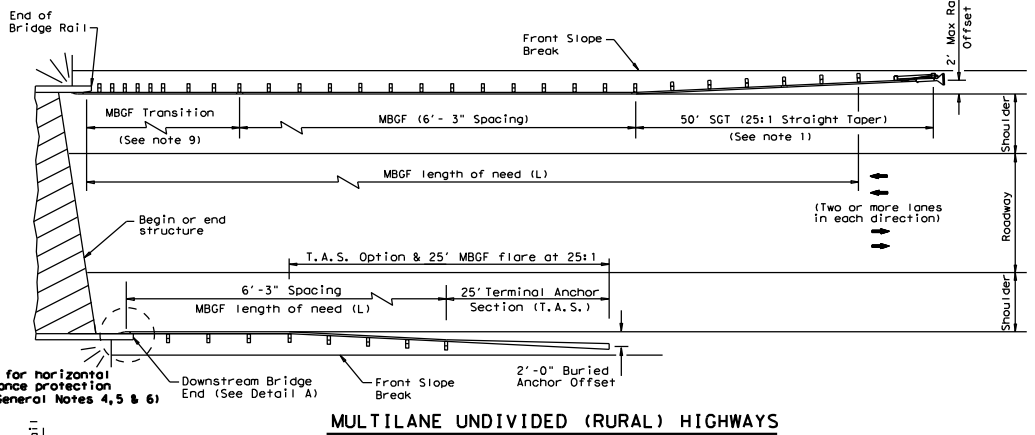
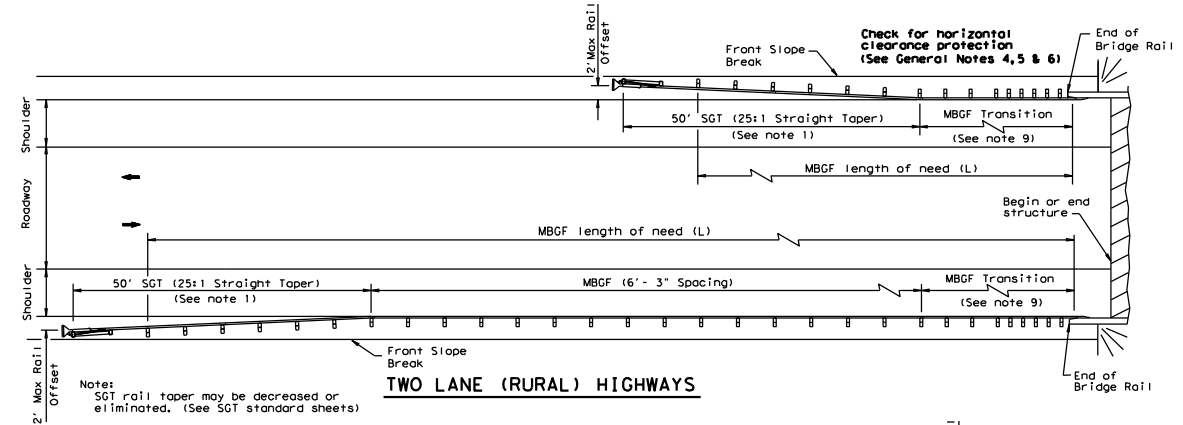

GENERAL NOTES

- For more detail: See MBEF, SGT, and MBEF Transition standard sheets.
- Quantities of metal beam guard fence (MBGF) at individual bridge ends are shown elsewhere in plans.
- Use average daily traffic (ADT) for the current year to determine MBEF length of need in accordance with the Roadway Design Manual unless otherwise specified. Where significant traffic volume growth is anticipated on low volume (0-750 ADT) highways, use length determinations for the higher volume category.
- MBGF may not be required to shield departure end of bridge unless other obstacles within the horizontal clearance limits or opposing traffic indicate a MBEF consideration.
- Terminal anchor sections (TAS) are only for downstream end anchorage use, outside the horizontal clearance area of opposing traffic.
- Direct connection of MBEF (at 6'-3" post spacing without transition) to concrete rail are only for downstream rail connections outside the horizontal clearance area of opposing traffic. (See Detail A)
- The crown shall be widened to accommodate MBEF. Typically the "front slope" break should be 2'-0" from the back of the MBEF post. This applies to new construction on new alignment or where existing roadway cross section is to be widened to increase roadway width. This does not apply to rehabilitation work where existing roadway crown width is to be retained (See Typical Cross Section of MBEF).
- For restrictive bridge widths: The MBEF should be properly transitioned from the existing bridge rail to the adjoining MBEF (See MBEF Transition Standards). Metal beam guard fence at these bridge location(s) shall be flared at the rate of 25:1 or flatter, and be of the length necessary to locate the terminal end at the 2 ft. "maximum" offset from the shoulder edge.
- Transition length and post spacing will vary depending on the transition type. Transition type will be shown elsewhere in the plans.

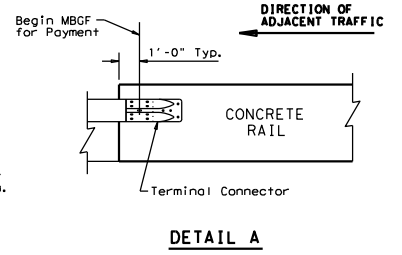
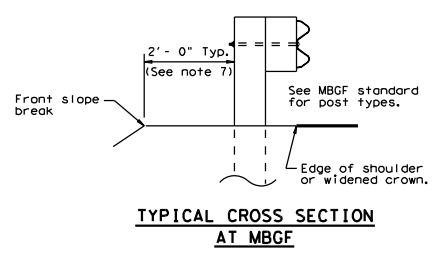

ONLY FOR USE IN MAINTENANCE REPAIRS.

Texas Department of Transportation				Design Division Standard	
BRIDGE END DETAILS (28" METAL BEAM GUARD FENCE APPLICATIONS TO RIGID RAILS) BED(28)-19					
FILE: bed2819.dgn	DN: TxDOT	CR: KM	DN: BD	CR: VP	
NOVEMBER 2019	CONT: 6417	SECT: 38	JOB: 001	US 96, etc.	
	DIST: LFK	COUNTY: San Augustine	SHEET NO: 54		

DISCLAIMER: This standard is covered by the "Texas Engineering Practice Act". No warranty of any kind is made by TxDOT for any purpose whatsoever. TxDOT assumes no responsibility for the conversion of this standard to other formats or for incorrect results or damages resulting from its use.
 DATE: 11/17/2022 2:56:11 PM
 FILE: T:\L\FKDMaint Contracts\0-RMC - Routine Maintenance Contracts\123 Plans\6417-38-001 San Augustine MBGF\DDN\STANDARD\BRIDGE\BED-14.dgn

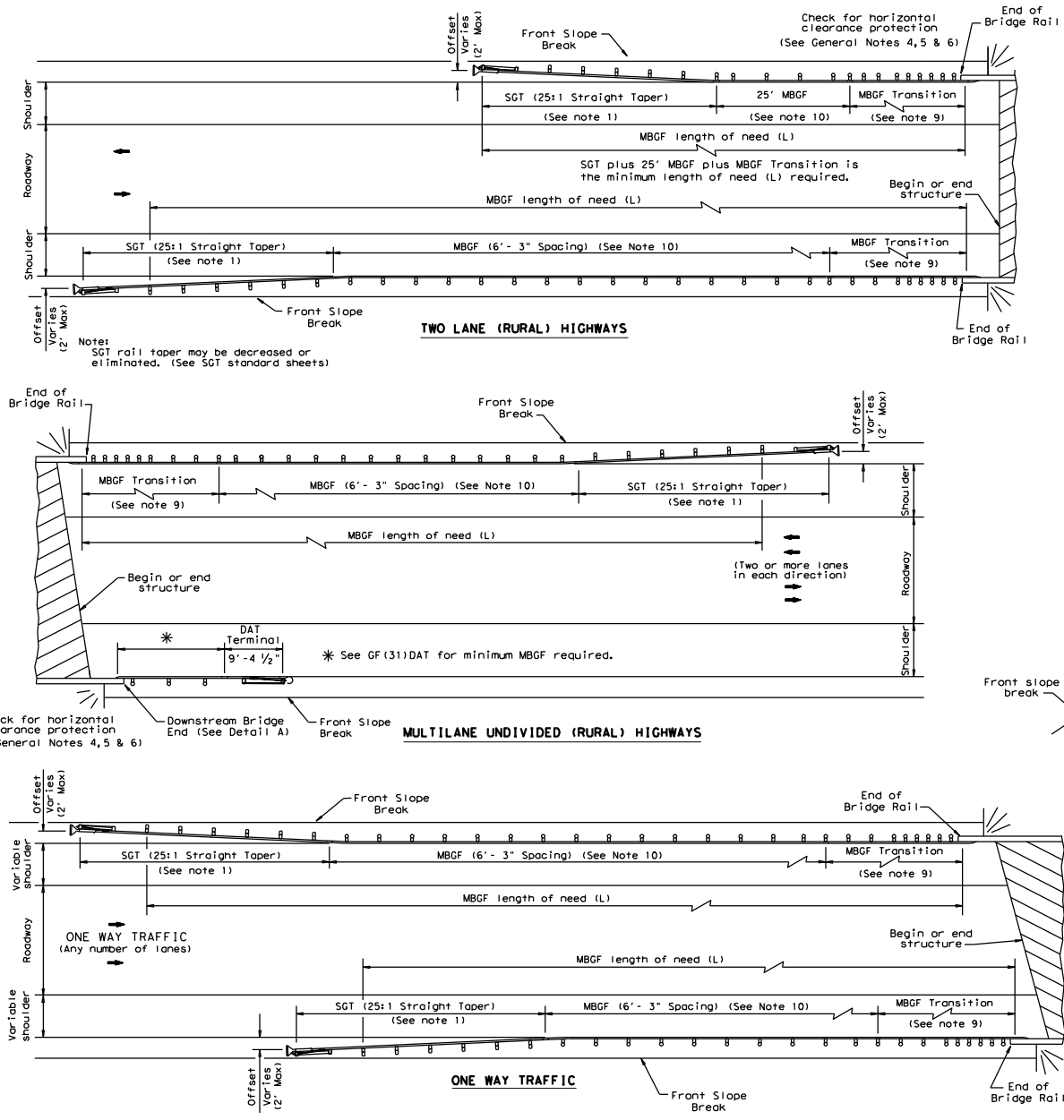

GENERAL NOTES

- For more detail: See GF (31), SGT (131), GF (31)TR, and GF (31)TL2 standard sheets.
- Quantities of metal beam guard fence (MBGF) at individual bridge ends are as shown in the plans.
- Use average daily traffic (ADT) for the current year to determine MBGF length of need in accordance with the Roadway Design Manual unless otherwise specified. Where significant traffic volume growth is anticipated on low volume (0-750 ADT) highways, use length determinations for the higher volume category.
- MBGF may not be required to shield departure end of bridge unless other obstacles within the horizontal clearance limits or opposing traffic indicate a MBGF consideration.
- Downstream anchor terminals (DAT) are only for downstream end anchorage use, outside the horizontal clearance area of opposing traffic.
- Direct connection of MBGF to concrete rails are only for downstream rail connections outside the horizontal clearance area of opposing traffic. (This requires a minimum of three standard line posts plus the DAT terminal, See Detail A)
- The crown shall be widened to accommodate MBGF. Typically the "front slope" break should be 2'-0" from the back of the MBGF post. This applies to new construction on new alignment or where existing roadway cross section is to be widened to increase roadway width. This does not apply to rehabilitation work where existing roadway crown width is to be retained (See Typical Cross Section of MBGF).
- For restrictive bridge widths: The MBGF should be properly transitioned from the existing bridge rail to the adjoining MBGF (See MBGF Transition Standards). Metal beam guard fence at these bridge location(s) shall be flared at the rate of 25:1 or flatter, and be of the length necessary to locate the terminal end at the 2 ft. "maximum" offset from the shoulder edge in the approach direction.
- Transition length and post spacing will vary depending on the transition type. Transition type will be shown elsewhere in the plans.
- A minimum 25' length of MBGF will be required.

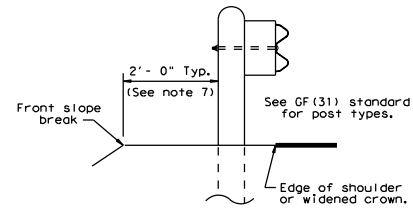

TYPICAL CROSS SECTION AT MBGF

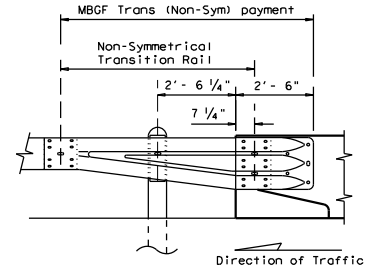

DETAIL A
Showing Downstream Rail Attachment

		Design Division Standard	
BRIDGE END DETAILS (METAL BEAM GUARD FENCE APPLICATIONS TO RIGID RAILS) BED-14			
FILE: bed14.dgn	DN: TxDOT	CR: AM	DR: BD/VP
© TxDOT: December 2011	CONT SECT	JOB	HIGHWAY
REVISED APRIL 2014	6417 38	001	US 96, etc.
REL: NEW 04/14	DIST	COUNTY	SHEET NO.
	LFK	San Augustine	55

11/17/2025 2:57:48 PM T:\L\K\DM\Work\T-Contracts\Q-RMC - Routine Maintenance Contracts\FY23 Plans\6417-38-001 San Augustine MBGF\CONV\STANDARD\INFORMATIONAL SHEETS\TYPE T101 For Info Only.dgn

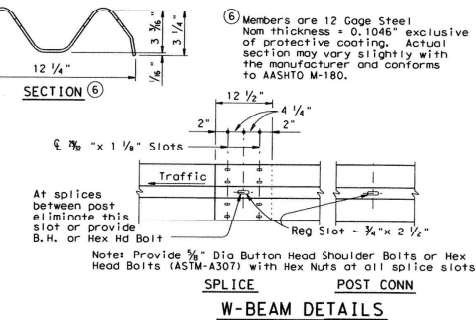
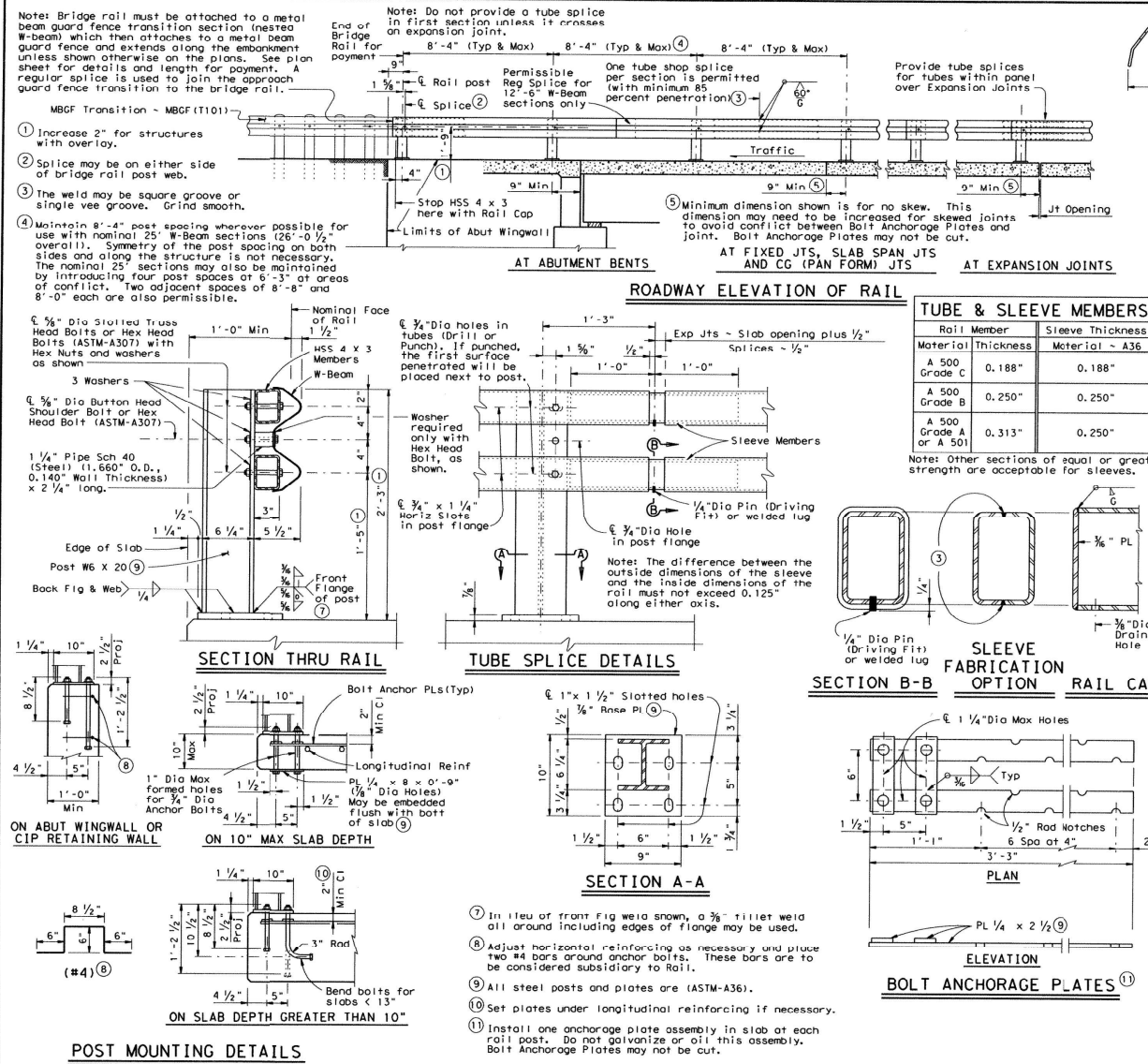

Texas Department of Transportation
Bridge Division

TRAFFIC RAIL

TYPE T101

FILED: r1st003.dgn	DATE: TXDOT	DATE: TXDOT	DATE: JTR	DATE: CJK	DATE: JMH
TXDOT	APR 11 2009	DISTRICT:	PROJECT NO.:	4E	SHEET
REVISIONS:	LFK	RMC	6253-82-001	4E	
	COUNTY:	CONTROL	SECTION	JOB	HIGHWAY NO.
	MCCORDITIES	6253	82 001	58 1	ELC

"AS BUILT"
TYPE T101

STATE	DIST.	COUNTY
TEXAS	LFK	San Augustine
CONT.	SECT.	JOB
6417	38	001
US 96, etc.		

FOR INFORMATIONAL PURPOSES ONLY

11/17/2023 2:58:15 PM T:\L\K\DO\N\G\T\ Contracts\Q\PMC - Routine Maintenance Contracts\FY23 Plans\6417-38-001 San Augustine MBGF\CON\STANDARD\INFORMATIONAL SHEETS\TYPE6FORINFOONLY.dgn

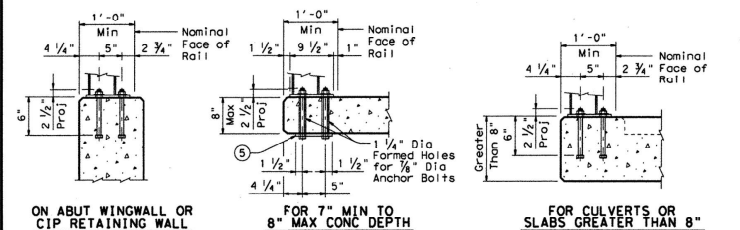
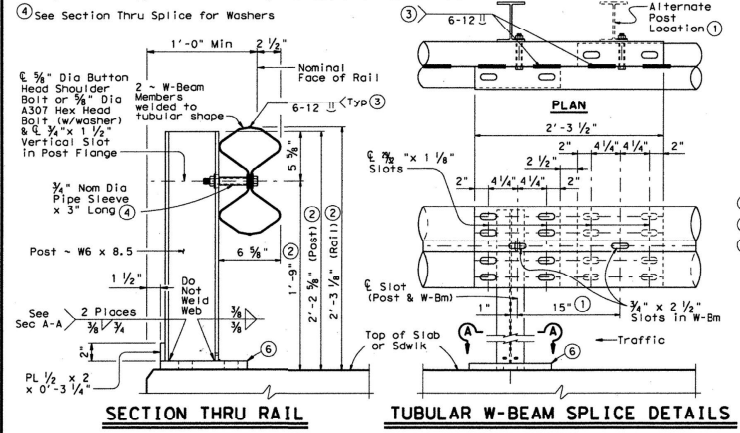
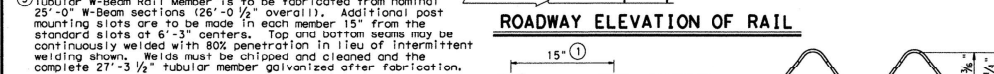
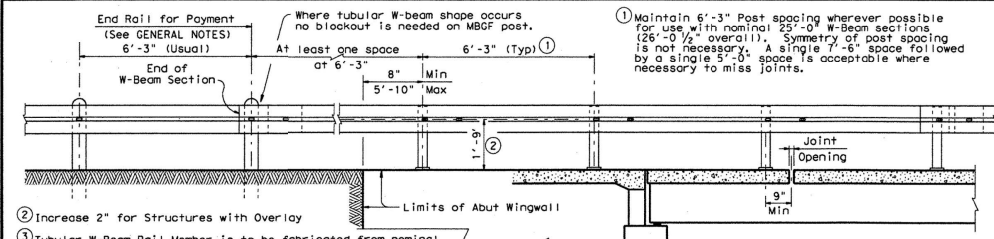

- ⑤ PL 1/2 x 6 x 0'-8" (3/8" Dia Holes)
- ⑥ PL 3/4 x 9 1/2 x 1'-0"
- ⑦ 8 - 3/8" Splice nuts. Tack weld to bent sheet metal positioners as shown. Other suitable positioning methods or devices may be substituted. The complete splice must have 16 bolts. Each bolt will include a 1/4" x 3" x 3/8" plate washer or a 1 1/4" O.D. washer.

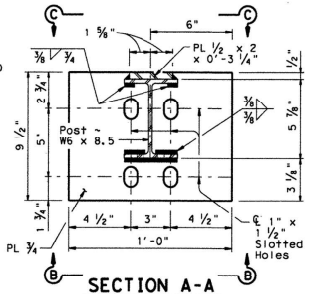
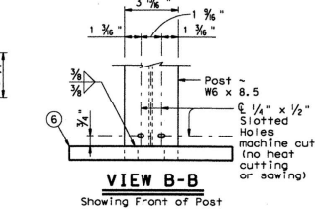
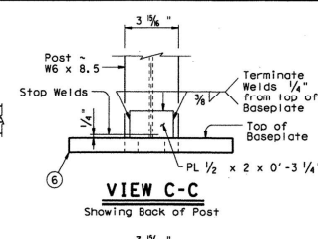
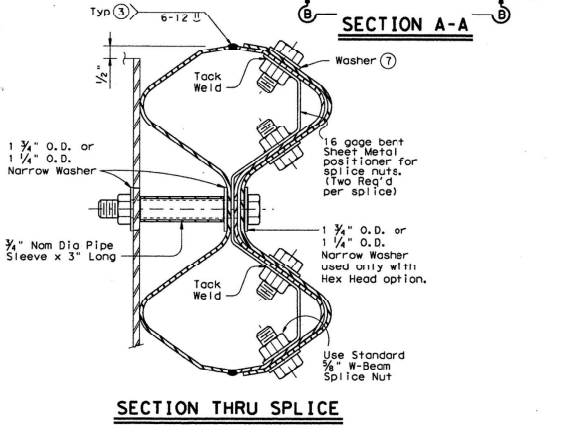

CONSTRUCTION NOTES:
 Tubular Rail Member must be extended and connected to at least the first soil embedded post at each end of the structure. More such posts must be used to utilize 25' standard sections. Approach guard fence posts must be spaced at 6'-3" adjacent to the Tubular Rail since its flexibility is similar to standard metal beam guard fence. Do not install additional posts at 3'-1 1/2" centers.
 Rail must be extended across all fixed armor joints, slab span joints, or pan form joints with no change in post spacing or continuity. At expansion armor joints of 1/4" or less, the splice bolts nearest the joint and post mounting bolts at intervening post must be snugly tightened to allow for rail expansion. At expansion armor joints over 1/4", suitably larger splice holes must be provided.
 Face of rail and posts must be vertical transversely unless otherwise approved by the Engineer. Posts must be perpendicular to adjacent roadway grade. Use epoxy mortar under post base plates if gaps larger than 1/8" exist.

MATERIAL NOTES:
 All steel components except reinforcing must be galvanized unless otherwise shown in plans.
 Anchor bolts must be 3/8" Dia ASTM A307 Grade A bolts (or #36 threaded rods with one lock welded hex nut each) with one hex nut and one hardened steel washer at each bolt (1 1/4" O.D. or 2" O.D. as directed by the Engineer). Clipped washers may be used as necessary. Threaded rods may be 0.7878 minimum diameter with rolled threads. Nuts must conform to A563 requirements.

GENERAL NOTES:
 This rail was evaluated based on the results of previous crash tests and approved for a NCHRP Report 350 TL-2 rating. The T6 rail is only approved for low speed use, design speeds of 45 mph and less.
 This railing cannot be used on bridges with expansion joints providing more than 4" movement.
 Rail anchorage details shown on this standard may require modification for select structure types. See appropriate details elsewhere for these modifications.
 Payment for this rail must be in increments of 25'. Shop drawings to be submitted to the Engineer for approval are required only for the proposed rail splices at expansion joints greater than 1/4". For rails not requiring shop drawings, erection drawings showing splice locations must be submitted to the Engineer for approval.
 Average weight of railing (6'-3" Post spacing and no Overlay) = 23 plf.

DESIGN/REPAIR CRITERIA
 The posts of this rail are designed to break away on impact from an errant vehicle. The rail is designed to deflect approx. two to three feet as it contains and redirects the errant vehicle. This rail may not be installed on top of or behind curbs that project above finished grade.
 Fully anchored guardfence must be attached to each end of rail.
 Repairs to impact-damaged post/baseplate units are not permitted. All impact-damaged posts must be replaced with a new post/baseplate unit.
 This railing is especially suitable for use on bridge width box culverts. The detail sheet titled "Box Culvert Mounting Details For Type 16 Rail, T6-CM" is then required, showing culvert curbs and wingwall modifications and additional reinforcing steel to be included as part of the railing for payment.

The use of this railing is restricted to design speeds of 45 mph or less and to horizontal curves with radius greater than 1000 feet.

Texas Department of Transportation
Bridge Division

TRAFFIC RAIL

TYPE T6

FILE #	T16T001.000	CONTRACT	6417-38-001	REV	01	DATE	12/01/2023
PROJECT NO.	6417-38-001	SHEET NO.	57				
REVISIONS	LFK	RMC	6233-29-001	33			
	COUNTY	CONTROL	SECTION	JOB	HIGHWAY		
	POI: K	6233	29	US	68		

"AS BUILT"
TYPE T6

STATE	DIST.	COUNTY
TEXAS	LFK	San Augustine
CONT.	SECT.	JOB
6417	38	001
PROJECT NO.		SHEET NO.
RMC 6417-38-001		57
HIGHWAY NO.		
US 96, etc.		

FOR INFORMATIONAL PURPOSES ONLY

11/17/2023 2:58:50 PM T:\L\KDD\MO\mfc\contracts\O&M - Routine Maintenance\contracts\F23 Plans\6417-38-001 San Augustine MBSF\NONSTANDARD INFORMATIONAL SHEETS\TYPE T101RC\InfoOnly.dgn

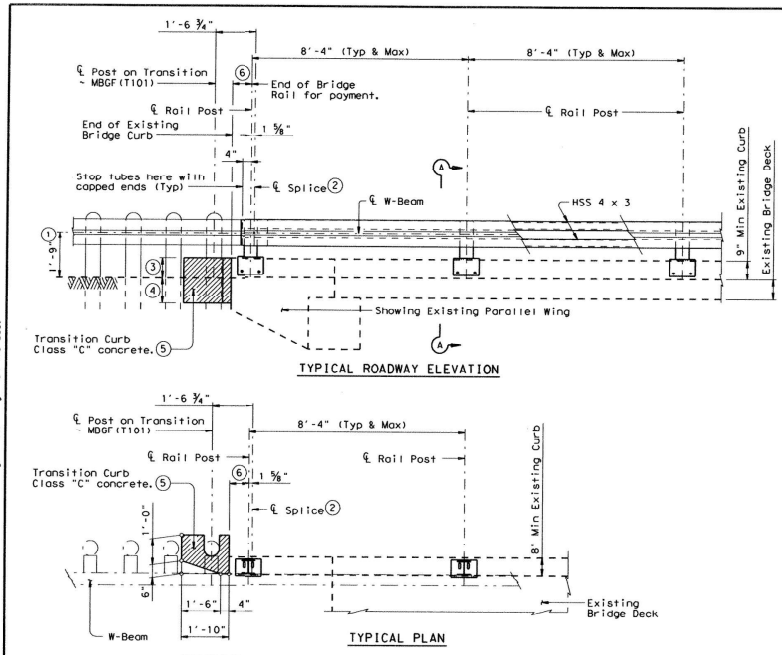

EXAMPLE "A" RETROFIT WITH PARALLEL WING
(Showing 9' high and 8" wide curbs, higher and wider curbs similar)

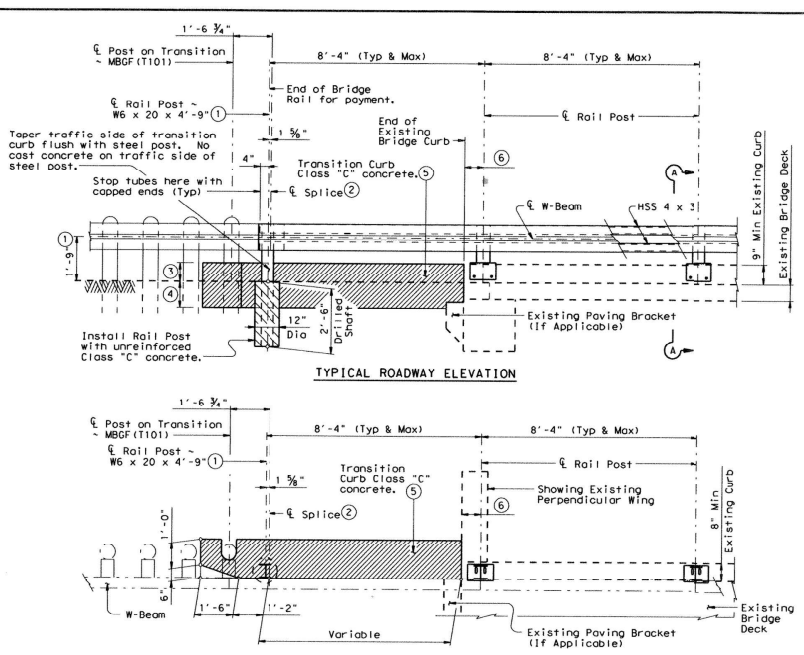

EXAMPLE "B" RETROFIT WITH PERPENDICULAR WING
(Showing 9' high and 8" wide curbs, higher and wider curbs similar)

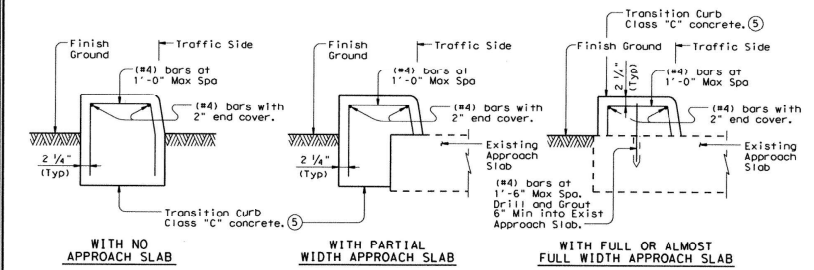

EXAMPLES OF TRANSITION CURB SECTIONS
(Reinforcement may be omitted for transition curbs less than 2 ft long).

- ① Increase by amount of existing overlay/seal coat thickness, not to exceed 2". If thickness of existing overlay/seal coat is greater than 2" at toe of rail, taper overlay at a 1:10 or flatter slope over the shoulder width to a thickness of 2" or less at toe of rail.
- ② Splice may be on either side of bridge rail post web.
- ③ Match existing bridge curb height.
- ④ Cast transition curb 1'-0" into soil or top of concrete approach slab.
- ⑤ Match existing bridge curb face on traffic side of transition curb. Transition curb 6" x 1'-6" taper will remain vertical.
- ⑥ Minimum distance from end of curb or open joint in curb to post centerline is existing curb height without overlay/seal coats, but not less than 9".
- ⑦ Details similar to Example "A" may be used if no existing structure components (like paving brackets) interfere with or prevent locating first transition post at 1'-6 3/4" adjacent to first rail post splice on existing structure.



SHEET 1 OF 3

Texas Department of Transportation
Bridge Division

RETROFIT GUIDE FOR T101 RAIL ON CURBS

TYPE T101RC (MOD)

FILE: F1810223.dgn	DATE: 11/01/2009	CHK: 11/01/2009	DES: JTR	CHK: JMI
REV: 1	DATE: 11/01/2009	BY: LFK	DESCRIPTION: RMC 6253-82-001	SHEET: 47
COUNTY: LFK				PROJECT NO.: RMC 6417-38-001
DISTRICT: 6				JOB: 001
CONTRACT: 6253				SECTION: 82
SUBSECTION: 001				JOB: 96
JOB: 96				SECTION: 001

SHEET 1 OF 3

**"AS BUILT"
TYPE T101RC
(MOD)**

TEXAS DEPARTMENT OF TRANSPORTATION
©2023

FILE: R01	PROJECT NO.: RMC 6417-38-001	SHEET NO.: 58
DATE: 01/15/2023	DISTRICT: 6	JOB: 001
STATE: TEXAS	DIST.: LFK	COUNTY: San Augustine
CONT.: 6417	SECT.: 38	JOB: 001
HIGHWAY NO.: US 96, etc.		

FOR INFORMATIONAL PURPOSES ONLY

11/17/2023 2:58:53 PM T:\LK\DDM\Info\Info - Contracts\O&M - Routine Maintenance - Contracts\FY23 Plans\6417-38-001 San Augustine MBGF\CONV\STANDARD\INFORMATIONAL SHEETS\Type T101RC\InfoOnly.dgn

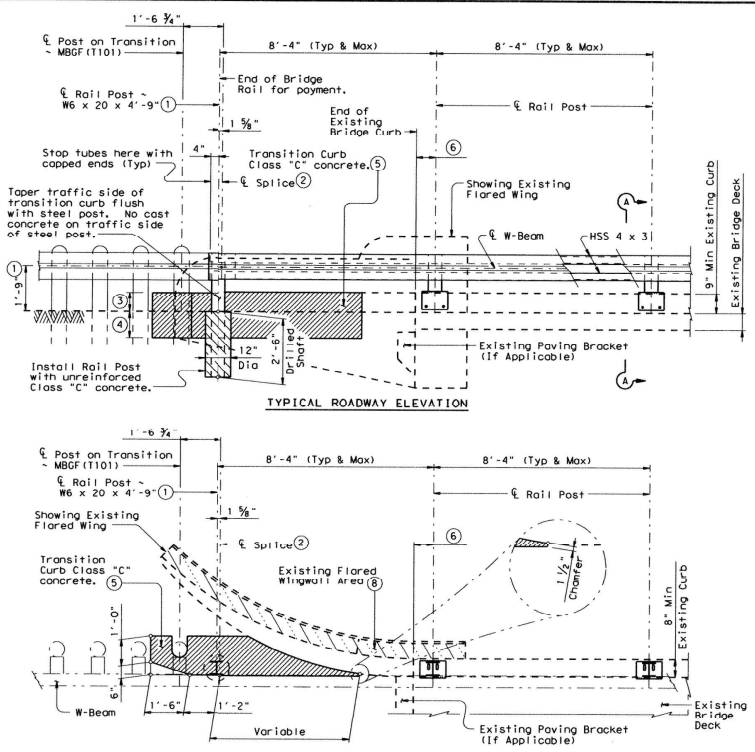

EXAMPLE "C" RETROFIT WITH FLARED WING
(Showing 9" high and 8" wide curbs, higher and wider curbs similar)

- ① Increase by amount of existing overlay/seal coat thickness, not to exceed 2". If thickness of existing overlay/seal coat is greater than 2" at toe of rail, taper overlay at a 1:10 or flatter slope over the shoulder width to a thickness of 2" or less at toe of rail.
- ② Splice may be on either side of bridge rail post web.
- ③ Match existing bridge curb height.
- ④ Cast transition curb 1'-0" into soil.
- ⑤ Match existing bridge curb face on traffic side of transition curb. Transition curb 6" x 1'-6" taper will remain vertical.
- ⑥ Minimum distance from end of curb or open joint in curb to post centerline is existing curb height without overlay/seal coats, but not less than 9".
- ⑦ Remove all existing structure area from top of existing curb. Cut and grind all existing reinforcing extending from top of existing curb flush and point ends with two coats of zinc-rich paint conforming to the Item "Galvanizing".

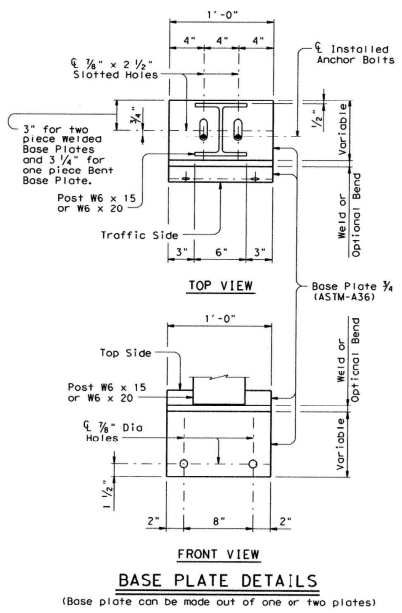

David R. Collmorgen
4-11-13

Notes: Bridge rail must be attached to the MBGF (T101) transition which then attaches to a metal beam guard fence and extends along the embankment. The splice joining the approach guard fence transition to the bridge rail requires 1'-6 3/4" post spacing. Do not provide a tube splice in first section unless it crosses an expansion or armor joint. Maintain 8'-4" post spacing wherever possible for use with nominal 25" W-Beam sections (26'-0 1/2" overall). Symmetry of the post spacing on both sides and along the structure is not necessary. The nominal 25" sections may also be maintained by introducing four post spaces of 6'-3" at areas of conflict. Two adjacent spaces of 8'-8" and 8'-0" each are also permissible.

CONSTRUCTION NOTES:
 Panel lengths of tube members must be attached continuously to a minimum of three posts (except at abutments with expansion joints).
 Rail Posts must be set perpendicular to adjacent roadway grade. Use epoxy mortar under post base plates if gaps larger than 1/8" exist.
 At expansion slots in W-Beam rail, tighten bolts snugly.

MATERIAL NOTES:
 All steel components except reinforcing must be galvanized unless otherwise shown in plans.

GENERAL NOTES:
 A similar full-height railing (T101) has been evaluated to meet NCHRP Report 350 Test Level 3 (TL-3) or higher. This retrofit railing has been structurally evaluated to have strength equal to or exceeding that of the tested railing. See Traffic Rail Type T101 standard for details and notes not shown herein. Using this sheet with the T101 standard, note that anchor bolts, bolt anchor plates, post base plate and post lengths are not used as shown on the T101 standard. This sheet replaces or omits some items on the T101 standard.
 All bolts, nuts, washers, adhesive anchors, reinforcing, and transition curb concrete are considered as parts of the rail for payment.
 Erection drawings showing panel lengths, splice locations, post spacing, anchor bolt locations and adhesive anchor test data to demonstrate pullout strength must be submitted to the Engineer for approval. Shop drawings will not be required.
 Avg weight with no overlay increase and with 0.25" tubest 38 pif (9", 11" & 12" Curbs)
 23 pif (18" Curbs)

SHEET 2 OF 3

Texas Department of Transportation
Bridge Division

**RETROFIT GUIDE FOR
T101 RAIL ON CURBS**

TYPE T101RC (MOD)

FILES	r1st023.dgn	DR	TxDOT	CR	TxDOT	DR	JTR	CR	JMH
DATE	01/11/2009								
DISTRICT	LFK	PROJECT NO.	RMC 6253-82-001	SHEET	48				
COUNTY	NACOGDOCHES	DATE PLOT	5/1	SCALE					

SHEET 2 OF 3

**"AS BUILT"
TYPE T101RC
(MOD)**

TEXAS DEPARTMENT OF TRANSPORTATION
©2023

FILE NO.	PROJECT NO.	SHEET NO.
6	RMC 6417-38-001	59
STATE	DIST.	COUNTY
TEXAS	LFK	San Augustine
CONT.	SECT.	JOB
6417	38	001
HIGHWAY NO.	US 96, etc.	

FOR INFORMATIONAL PURPOSES ONLY

11/17/2023 2:58:57 PM T:\L\KIDMAN\Info\T101RC\Info\Info\11.dgn - Routine Maintenance, Contracts\FY23 Plans\6417-38-001, San Augustine Bridge\CONV\STANDARD\INFORMATIONAL SHEETS\TYPE T101RC\Info\Info\11.dgn

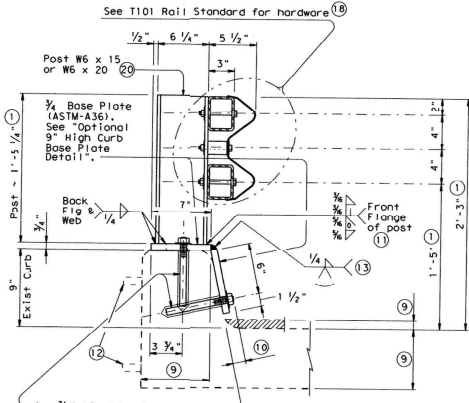

SECTION A-A OF 9" HIGH CURBS
(Showing example of 8" Min width curb, wider curbs similar)

4 - 3/4" Dia Adhesive Anchors with 2" O.D. washers. Min pullover tensile strength of 20,000 Lbs each anchor. Minimum embedment depth is 6 1/2". (14)

OPTIONAL 9" HIGH CURB BASE PLATE DETAIL
(Bend one piece base plate)

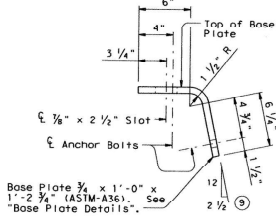

Base Plate 3/4 x 1'-0" x 1'-2 1/2" (ASTM-A36). See "Base Plate Details".

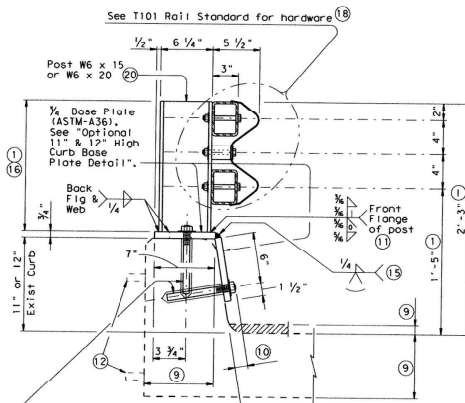

SECTION A-A OF 11" & 12" HIGH CURBS
(Showing example of 8" Min width curb, wider curbs similar)

4 - 3/4" Dia Adhesive Anchors with 2" O.D. washers. Min pullover tensile strength of 20,000 Lbs each anchor. Minimum embedment depth is 6 1/2". (14)

OPTIONAL 11" & 12" HIGH CURB BASE PLATE DETAIL
(Bend one piece base plate)

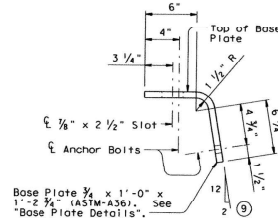

Base Plate 3/4 x 1'-0" x 1'-2 1/2" (ASTM-A36). See "Base Plate Details".

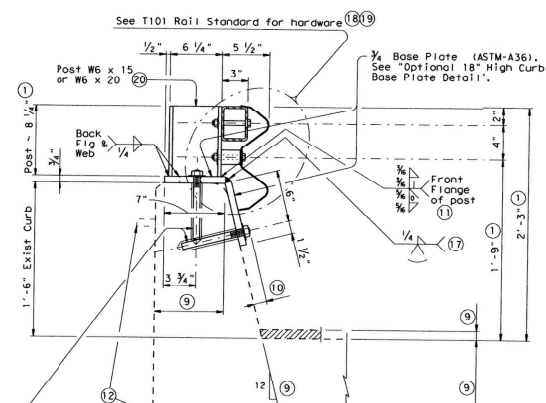

SECTION A-A OF 18" HIGH CURBS
(Showing example of 8" Min width curb, wider curbs similar)

4 - 3/4" Dia Adhesive Anchors with 2" O.D. washers. Min pullover tensile strength of 20,000 Lbs each anchor. Minimum embedment depth is 6 1/2". (14)

OPTIONAL 18" HIGH CURB BASE PLATE DETAIL
(Bend one piece base plate)

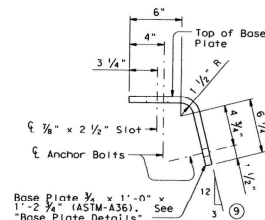

Base Plate 3/4 x 1'-0" x 1'-2 1/2" (ASTM-A36). See "Base Plate Details".

- (1) Increase by amount of existing overlay/seal coat thickness, not to exceed 2". If thickness of existing overlay/seal coat is greater than 2" at toe of rail, taper overlay at a 1:10 or flatter slope over the shoulder width to a thickness of 2" or less at toe of rail.
- (9) See elsewhere in plans for dimensions (Curb width and height, slab and overlay thickness). Slope of curb may differ from what is shown. Adjust base plate as necessary to conform to curb face geometry.
- (10) 1 1/2" Bolt Projection (Typ).
- (11) In lieu of front flange weld shown, a 3/8" fillet weld all around including edges of flange may be used.
- (12) Remove existing railing (including posts), cut and grind anchor bolts flush and point ends with two coats of zinc-rich paint conforming to the item "Galvanizing".
- (13) Complete joint penetration weld. Optional one piece base plate may be used. See "Optional 9" High Curb Base Plate Detail".

- (14) Hole size, hole cleaning and other installation requirements must conform to manufacturer's Instructions. Use a Type III Class C epoxy.
- (15) Complete joint penetration weld. Optional one piece base plate may be used. See "Optional 11" & 12" High Curb Base Plate Detail".
- (16) On 11" Curbs, Posts are 1'-3 1/4". On 12" Curbs, Posts are 1'-2 1/4".
- (17) Complete joint penetration weld. Optional one piece base plate may be used. See "Optional 18" High Curb Base Plate Detail".
- (18) See T101 standard for details and notes not shown.
- (19) This retrofit condition will only accommodate one top HSS 4 x 3 member under W-Beam.
- (20) See T101 standard for post spacing, unless shown otherwise.



David R. Collmorgen
4-11-13

SHEET 3 OF 3

Texas Department of Transportation
Bridge Division
RETROFIT GUIDE FOR T101 RAIL ON CURBS

TYPE T101RC (MOD)

FILE: r1816023.dgn	DR: TADOT	CHK: TADOT	DR: JTR	CHK: JHM
① 1-001	APR 11 2009	DISTRICT	PROJECT NO.	SHEET
REVISIONS	LFK	RMC	6253-82-001	49
COUNTY	CONTROL	SECT	JOB	HIGHWAY
MCGOODRICH	6253	82	001	91, etc.

SHEET 3 OF 3

"AS BUILT"
TYPE T101RC
(MOD)

TEXAS DEPARTMENT OF TRANSPORTATION ©2023					
FILE NO:	PROJECT NO.			SHEET NO.	
011-001	6 RMC 6417-38-001			60	
STATE	DIST.	COUNTY			
TEXAS	LFK	San Augustine			
CONT.	SECT.	JOB	HIGHWAY NO.		
6417	38	001	US 96, etc.		

FOR INFORMATIONAL PURPOSES ONLY

